



32101 064517483

THE ENCYCLOPEDIA  
BRITANNICA





981  
325  
12  
v. 30

**ANNEX LIB.**

Library of



Princeton University.













# THE ENCYCLOPÆDIA BRITANNICA.

## NEW VOLUMES

FIRST	edition, published in three	volumes,	1768—1771.
SECOND	" "	ten "	1777—1784.
THIRD	" "	eighteen "	1788—1797.
FOURTH	" "	twenty "	1801—1810.
FIFTH	" "	twenty "	1815—1817.
SIXTH	" "	twenty "	1823—1824.
SEVENTH	" "	twenty-one "	1830—1842.
EIGHTH	" "	twenty-two "	1853—1860.
NINTH	" "	twenty-five "	1875—1889.
TENTH	" ninth edition and eleven supplementary volumes,		1902—1903.
ELEVENTH	" published in twenty-nine volumes,		1910—1911.
TWELFTH	" eleventh edition and three new volumes,		1921—1922.



**COPYRIGHT**  
in all countries subscribing to the  
**Bern Convention**  
by  
**THE ENCYCLOPÆDIA BRITANNICA COMPANY, LTD.**

*All rights reserved*

**THE  
ENCYCLOPÆDIA BRITANNICA**

**THE NEW VOLUMES**

CONSTITUTING, IN COMBINATION WITH THE EXISTING VOLUMES  
OF THE ELEVENTH EDITION,

**THE TWELFTH EDITION**

OF THAT WORK, AND ALSO SUPPLYING  
A NEW, DISTINCTIVE, AND INDEPENDENT LIBRARY OF REFERENCE  
DEALING WITH EVENTS AND DEVELOPMENTS OF  
THE PERIOD 1910 TO 1921 INCLUSIVE

**THE FIRST OF THE NEW VOLUMES  
VOLUME XXX  
ABBE to ENGLISH HISTORY**

LONDON  
**THE ENCYCLOPÆDIA BRITANNICA COMPANY, LTD.**

NEW YORK  
**THE ENCYCLOPÆDIA BRITANNICA, INC.**

1922



1922

# ADVENTURE AND DISCOVERY

THE ENCYCLOPEDIA BRITANNICA

ADVENTURE AND DISCOVERY

ADVENTURE AND DISCOVERY

ADVENTURE AND DISCOVERY

ADVENTURE AND DISCOVERY

Copyright, in the United States of America, 1922

by

The Encyclopedia Britannica, Inc.

ADVENTURE AND DISCOVERY

ADVENTURE AND DISCOVERY

ADVENTURE AND DISCOVERY

ADVENTURE AND DISCOVERY

ADVENTURE

ADVENTURE AND DISCOVERY

DEDICATED BY PERMISSION

TO

THE TWO HEADS OF THE ENGLISH-SPEAKING PEOPLES

HIS MAJESTY GEORGE THE FIFTH

KING OF GREAT BRITAIN AND IRELAND

AND OF THE BRITISH DOMINIONS BEYOND THE SEAS

EMPEROR OF INDIA

AND

WARREN GAMALIEL HARDING

PRESIDENT OF THE UNITED STATES OF AMERICA

5-22-23 P. S. St. George. Brit. No. 2570

~~100~~  
0931  
325  
.12  
430  
(RECAP)

511146



## EDITORIAL PREFACE

IF it had not been for the World War, there would not have been any occasion, so early as 1922, for a Supplement to the Eleventh Edition of the *Encyclopædia Britannica*, as published in 1911. But for the exceptional situation so created, the original intention not to take in hand anything equivalent to a Twelfth Edition until a much later date would undoubtedly have been maintained.

So colossal a convulsion, however, as that of the war, with consequences shown in so many unexpected directions and radically changing the world-outlook under the new conditions, made the need for this prompt addition to universal history absolutely imperative, as a record and illumination of so peculiarly dark and complex a period. The gap between 1911 and 1921 is all the more noticeable because, from the middle of 1914 onwards, authentic history could not be written at all, as had been practicable normally under earlier peace conditions, in such periodical publications as have usually served the requirements of the public for purposes of reference on contemporary affairs. The very nature of the war, and of the war conditions which persisted even after the Armistice, not only involved the imposition of secrecy, the cutting off of intercommunication, and even an interested perversion of fact in much that was given out for belief, but also led to a state of paralysis and aphasia in the spheres where, before the war, independent observation and judgment were to be found. Attention was monopolized everywhere by conditions of urgency and emergency, and concentrated upon the immediate conduct of life, while almost every expert, whether in scholarship or in science, was living, so to speak, from hand to mouth, with his accustomed intellectual activities interrupted, suspended, or diverted.

In such circumstances there arose inevitably a clear call for the publication of a Supplement to the *Encyclopædia Britannica* at as early a date as was practicable after the war, conformably with the arrival of a stage in post-war reconstruction which would once more enable its Editor to secure a reasonable modicum of the disinterested international coöperation on which the value of the *Encyclopædia Britannica*, as a critical record of world-history, has so long depended.

These New Volumes of the *Encyclopædia Britannica* accordingly follow precedents established during the 154 years since it made its first appearance in 1768. Between its Third (1788-97) and Fourth (1801-10) Editions, a two-volume Supplement (1801) to the Third Edition was published; and while the Fifth Edition (1815-7, a reprint of the Fourth) was still current, and the reëdited Sixth (1823-4) was nearly ready for issue, a "Supplement to the Fourth, Fifth and Sixth Editions," edited by Macvey Napier, appeared in six volumes during 1816-24. In 1902 again, by way of supplement to the Ninth Edition (1875-89), there were published eleven New Volumes, forming in combination with it the Tenth Edition, for the general editorship of which the present writer, taking over the task early in 1900 from the late Sir Donald Mackenzie Wallace, was responsible. Incidentally

those eleven New Volumes set a new precedent in publications of this kind by being prepared and issued simultaneously, and the same method was subsequently adopted in the preparation of the Eleventh Edition (1911).

Had it not been for the war, the twenty years between the average date of the Ninth Edition (25 Volumes, 1875-80) and the date of its supplementary New Volumes, which were added to form the Tenth Edition (1902), may be regarded as indicating the length of interval which might well have been expected to follow the publication of the Eleventh Edition before it in turn had a supplement added to it, to form in combination with it the Twelfth Edition. The course now taken, however, is directly in line with Macvey Napier's great Supplement (1816-24) to the Fourth, Fifth and Sixth Editions. The extent of that Supplement exhibited, indeed, a notable advance in the whole standard of the *Britannica* as a work of original scholarship and expert authority—the result of the copyrights having recently passed into the hands of the enterprising publisher Constable; but its interest in this particular connexion lies in the fact that it was conceived as a response to the pressing demand for a comprehensive survey of the situation resulting from the Great War which had just ended at Waterloo in 1815. In 1816, when the first volume of Macvey Napier's Supplement appeared, the same need was felt for an authoritative record and reconsideration of the new developments during the convulsions of 1793-1815 as has arisen now in respect of the decade ending with 1921, and for very similar reasons. Anyone who still cares to examine that remarkable Supplement of 1816-24 will find that the ideals of public service in education set before themselves by Constable and Macvey Napier (as expressed by the latter in his Preface to the Sixth Volume) were identical with those which animate the *Encyclopædia Britannica* to-day. The present writer, having made this examination, with knowledge of the many difficulties of his own task a hundred years later (on the first subsequent occasion of an engrossing conflict having upset the world), is bound to testify to the admirable way in which, amid evidences of similar obstructions and complications, Macvey Napier carried out his scheme. His Supplementary Volumes, organized at the conclusion of the Great War of 1793-1815, formed the only critical and universal survey then available of the period just ended. They brought together a mass of valuable material which was afterwards incorporated in later editions; indeed much of this information, fresh from the sources, could only have been placed on record by being obtained at that time—a consideration which is encouraging to the Editor of the present New Volumes in regard to the permanent value of the material embodied in them also.

In one respect, possibly, Macvey Napier may appear to have had an advantage over the present Editor, or a somewhat easier task, in that he had eight years over which to spread the publication of his volumes—first issued in parts. But his successor a hundred years later is too conscious of the real advantage given to the public by immediate and simultaneous production, and indeed of the superior quality which such a work possesses, when the whole of it has been under editorial control at one time, to take this superficial view. Having himself organized the production of these New Volumes within a single year—a year, moreover, characterized by post-war unrest and unsettlement—he may perhaps make this difference of method some excuse, however, for any imperfections in them which may be found in the light of later events or of knowledge undisclosed

while they were in the making.<sup>1</sup> The generous reader may pardon some incidental defects or omissions, in consideration of his having the use, practically at once, of the full Supplement, as complete as it could reasonably be made, and not having to wait several years for a succession of volumes with long intervals between them. In the latter case each volume would be apt to exasperate him by cross-references from its articles to others in a volume still inaccessible; each earlier one, furthermore, would become relatively out-of-date as soon as the next one appeared; and the whole must lack organic unity, because the subject-matter, as distributed in one volume or another, must necessarily have been dealt with at different dates from dissimilar viewpoints.

These New Volumes, systematically arranged, in accordance with the traditional standards of the *Encyclopædia Britannica*, so that the articles may be adapted either for continuous reading or for occasional reference, have been planned as a guide to an appreciative understanding of contemporary affairs. The reader has before him what may be described as an international stock-taking, by carefully selected authorities, of the march of events all over the world from 1909-10 to 1920-1; and of the nature and critical value of such advances as were made in the principal branches of knowledge during that period. In this respect the New Volumes aim at giving a key to the problems of to-day, so far as these contemporary problems are bound up—as indeed they are to an unprecedented extent—with the new social and economic issues which only began to emerge in their present magnitude, or to impress themselves on the public, as the result of the tremendous upheaval caused by the World War. Yet it is necessary, in the interests of a publication which is essentially educational, to add one proviso. It remains as true as ever that contemporary human life and interests are organically related not only to the immediate developments of one preceding decade but to those of a succession of earlier decades and epochs, back to the abysses of time. The great Drama is of the Ages, and can only be appreciated with all its Acts on record. *The eye which looks only at the passing scene is too often, colour-blind.* The roots of the Post-War World go down into the Pre-War World. Its proper interpretation can be found only in the light of all that earlier history on which we can look back—as we cannot do on contemporary affairs—with assurance that it is seen in perspective and in ordered values, as the result of an accumulation of disinterested criticism. The Post-War World is the residuary legatee of the Pre-War World, from which it inherits the whole basis of its intellectual equipment. The present survey of recent happenings, indispensable though it may be as an account of the Post-War World, can truly therefore be utilized perfectly when it is regarded as an integral part of the unitary library of education represented in all the thirty-two volumes now forming the complete Twelfth Edition. The structure of that great edifice, with its contents, is not substantially affected by the fact that it has been built with an Annex for housing more recent

<sup>1</sup>It may be noted here that, though bibliographical references, representing a selection of the most authoritative books or documents published since 1910, are plentifully made in the New Volumes, it was impossible, merely by way of supplement to the bibliographies attached to articles in the Eleventh Edition, to include them systematically, except in appropriate cases where this course was demanded by the nature of the supplementary articles. No attempt has been made, when otherwise there was no substantial reason for adding a supplementary article at all to the account given of a subject in the Eleventh Edition, to add a list of later books published about it. (Nor, indeed, in the Editor's judgment, would it have been in accordance with the objects of the *Britannica* to give the cachet of "authority" in this way to many contemporary publications which can hardly be said to have earned that title.) The bibliographical references in the *Britannica* are especially valuable as critically directing the reader to the best sources, outside its own articles, for more detailed information; but the very nature of many of the articles in the New Volumes, as being the latest (or even the only available) authoritative accounts of purely contemporary developments, made it unnecessary—if indeed it would not be misleading—to direct the reader to comparatively ephemeral publications by less responsible writers.

acquisitions, in the shape of these New Volumes. They are designed as having behind or beside them the main body of the work—the earlier Volumes of the Eleventh Edition which were constructed in the closing years of the Pre-War World.

It may be pardonable for the present writer, at the end of the twenty-first year of his occupancy of the position of Editor of the *Encyclopædia Britannica*, to emphasize in retrospect one specially valuable characteristic of the Eleventh Edition, in supplying to-day an authoritative digest of world history and the progress of knowledge up to the last few months before it was originally published in 1911. Its value does not merely depend on the benefit secured to the reader of these New Volumes by its having also been produced as a whole at one date, so that its accounts of every subject, organically distributed under appropriate headings, represent uniformly a single editorial policy (identical with that of to-day), a common terminus of time in the facts dealt with, and a common standard of criticism in the viewpoints of its contributors—so far as expert opinion at any one moment is ever in agreement. This in itself is, no doubt, a great convenience in the linking up of the later information provided in the New Volumes.<sup>1</sup> But there is a still more important quality attaching to the Eleventh Edition, of which indeed its Editor was not himself fully aware during the critical years of its preparation. It required the experience obtained during the gestation of these New Volumes to teach the Editor how much simpler a matter it is to create such a "Library of Education" when the world is at peace and is progressing normally, as it was in the years preceding 1911, than when, as recently, it is everywhere in convulsion, nobody being able to tell from week to week what he would be doing next, or where some new complication or even revolution, political, economic, industrial or scientific, might break out, to the upsetting of any attempt at orderly statement of the progress of events and the crystallization of opinion. Though it was not so realized at the time, it is now evident that the maximum service which the *Encyclopædia Britannica* could have performed for the public of to-day was the production of the Eleventh Edition in 1911, before the war of 1914-9 cut a Grand Canyon gash in the whole intellectual structure of the world. For what would have happened if the complete new edition which would follow the Tenth Edition had not been undertaken until several years later—say, after the Armistice? In that case it would still have been necessary, in some way, to keep what may roughly be divided as the Pre-War and Post-War Worlds distinct. The account of the Post-War World would then substantially be what appears in the present New Volumes; for this must, in any case, start at a convenient point before the war, in order to make the break intelligible, and it must differ in scope and perspective from the part devoted to the Pre-War World, in proportion as its new problems require a different sort of discussion according to their bearing on the future rather than as continuations of past history. But so far as the Pre-War World is concerned—everything, that is to say, except the contemporary developments of the decade preceding 1921—it may be asserted, without fear of contradiction from anyone who can appreciate the responsibilities of an Editor of the *Encyclopædia Britannica*, that, if the task had not been undertaken till after 1914, it would have been absolutely impossible to produce to-day anything so comprehensively authoritative or critically complete as is actually available in the shape of the Eleventh Edition owing to its having been produced just before the war.

<sup>1</sup> Reference by volume and page (e.g. "see 2.493") is accordingly made, as a rule immediately after the headings of articles in the New Volumes (but also elsewhere in their course, as seemed useful), to places in the earlier volumes where accounts of the same subjects, leading up to the point where the account is now resumed, may be found.

In the present writer's judgment it is very remarkably the fact that, however carefully the contents of the Eleventh Edition are tested, as representing the highest standards of international research and criticism, whether in Science or in Art or in historical information, up to 1911, nothing substantial has occurred since to diminish its value or alter its perspective. The reason is that it was fortunately produced at a quiet period, when there was every opportunity for obtaining sure, authoritative and orderly surveys, in a world-society which was evolving along known lines of "normalcy"—to use President Harding's favourite expression—fairly calculable in advance in accordance with well-informed expectations, and permitting of a reasonably final judgment on the sequence of contemporary progress in relation to the past. To-day, on the other hand, the whole atmosphere of scholarship and thought has temporarily been vitiated by the world upheaval, and the coöperation enlisted for the Eleventh Edition is unattainable under present conditions. It is not too much to say that the service done by the *Encyclopædia Britannica* for the public, by bringing together in the Eleventh Edition its unique combination of the world's ripest judgments on every sort of subject, could not have been rendered to this generation at all if that Edition had not been completed before the war. As the composition of the present New Volumes shows, it has still been possible for the Editor to enlist the most highly qualified experts, and writers officially connected with Government Departments or Services, for dealing with matters familiar to them (and often known only to them) in the course of the past decade. But the writing of contemporary history by persons who have been chief agents or eye-witnesses is one thing; it is quite another to recreate the whole drama of the far-reaching past. To do that, as it was done in the Eleventh Edition, needs a type of mind and will which for the present has largely ceased to function along the pre-war ways.

Irrespectively, indeed, of the question whether as good a complete edition as the Eleventh could have been produced *de novo* now, it would cost in any case at least twice as much to make as it did in 1911, and it would have to be sold at a far higher price. But, from the editorial point of view, the important fact is that it could not be made to-day so as to have anything like the scholarly value of the work produced before the war by the contributors to the Eleventh Edition. Neither the minds nor the wills that are required for such an undertaking are any longer obtainable in any corresponding degree, nor probably can they be again for years to come. This is partly due to sheer "war-weariness," which has taken many forms. A shifting of interest has taken place among writers of the academic type, so that there is a disinclination to make the exertion needed for entering anew into their old subjects—a necessary condition for just that stimulating, vital presentation of old issues in the light of all the accumulated knowledge about them, which was so valuable a feature of the Eleventh Edition; the impulse has temporarily been stifled by the pressure of contemporary problems. Many of the pre-war authorities, moreover, have died without leaving any lineal successors, and others have aged disproportionately during the decade, while the younger generation has had its intellectual energies diverted by the war to work of a different order. Again (a most essential factor), it would have been impossible to attain the same full measure of international coöperation, among representatives of nations so recently in conflict, and in a world still divided in 1921 by the consequences of the war almost as seriously as while hostilities were actually raging.



It is with some satisfaction that the Editor has been able to make a fresh beginning in these New Volumes toward a revival of this coöperation, by including German, Austrian and Hungarian contributors, in addition to those from the countries allied or associated with the British Empire and the United States during the war. In the material structure of the New Volumes, and their sub-editing, the same note of Anglo-American solidarity is struck as in the Eleventh Edition; and this is again emphasized by their being dedicated jointly to the two Heads of the English-speaking peoples, by express permission of King George V. and President Harding. Nowhere except in Great Britain and the United States would it have been possible, under the world-conditions of 1921, to find the standard of poise and perspective required in their construction. Any other assumption, throughout these New Volumes, than that the terrible war of 1914-9 was won by those who had right and justice for their cause, would manifestly be impossible in the *Encyclopædia Britannica*; and historical justification for this belief is indeed given in the proper articles. On the other hand, many of the more violent criticisms of German action current during the war are now shown, in the Anglo-Saxon spirit of fair play, to have been exaggerated for "propaganda" purposes. Opinion on the incidents and issues of the war-period will probably continue to be revised by succeeding generations over and over again, as the weight of evidence, so much of it still undisclosed, increases; but a start is made here toward the acceptance of such conclusions as already represent a judicial view, expressed without favour or malice, free from any conscious bias, and backed by a presentation of the relevant facts on authority that is either admittedly unimpeachable or so far unchallenged. It was an integral part of the editorial policy to put aside any war-prejudice in inviting the assistance of contributors from among the nations which had fought against the Allies, so far as might be practicable without the intrusion of "propaganda," especially for narratives of the domestic history of the enemy countries, about which so little information had penetrated outside during the war-period. The list of writers of ex-enemy nationality, and of the articles contributed by them, shows that a considerable section of the contents, including the military history of the war itself (to which British, American, French, Italian, Belgian, German, and Austro-Hungarian soldiers have contributed); is derived from such sources; and this fact alone gives these Volumes a special interest. Consistently with this policy, the Editor has encountered only very rare disappointments in carrying out his plan of obtaining the best contributors available from all foreign countries, including Germany and Austria, in order to provide the most authoritative information on their own affairs according to their own respective standpoints. In this connection it will be noted that, for the first time in the history of the *Britannica*, the article on Japan is contributed by a Japanese. The Editor is glad here to acknowledge the help of the distinguished historian, Prof. A. F. Pribram, of Vienna, in organizing, with the collaboration of Dr. Redlich, the eminent Austrian jurist, the whole series of articles dealing with Austro-Hungarian subjects. He had also the valuable assistance of Mr. George Saunders, formerly *The Times* correspondent in Berlin, in obtaining the coöperation of German contributors and in supervising the translation and editing of their articles; while Mr. George Adam, *The Times* correspondent in Paris during 1913-9, performed the same function in respect of France. In the case of Russia, the Editor was fortunately able to rely on the great authority of Sir Paul Vinogradoff. The Editor's thanks for useful advice

and assistance with regard to the articles on other foreign countries are due to President Masaryk (Czechoslovakia), Prof. H. Pirenne, Rector of Ghent University (Belgium), Prof. L. V. Birck of Copenhagen (Denmark), Mons. M. Beza, of the Rumanian Legation in London (Rumania), Mons. D. Caclamanos, the Greek Minister in London (Greece), Mons. H. N. Bronmer, of the Netherlands Legation in London (Holland), Baron Alströmer, the Swedish Chargé d'Affaires in London (Sweden), and Mons. Erik Colbran, of the League of Nations.

So many individuals have, in one way or another, smoothed the Editor's path, either by suggesting the best-qualified contributors or by giving helpful advice on the subject-matter of articles, that he can only make a rather arbitrary selection here in naming some of the more conspicuous. Practically every national Government, either directly or through its accredited representatives, has aided his attempt to give international authority to the New Volumes, by encouraging the use of its own sources of information; and British official coöperation, as also American, has been generously sanctioned and utilised. By the courtesy of the Naval Intelligence Department of the British Admiralty, the editorial staff had access to all the historical materials it had collected from various parts of the world for secret service during the war, including the handbooks of statistical and general information which had been privately printed by the Government for the use of British officers and political agents while the war was still in progress, and which were only partially "released" for publication afterwards. In this connexion acknowledgment may be made here, once for all, of the permission accorded by the Geographical Section of the British War Office (supplemented by that of the Controller of H.M. Stationery Office), and by the French *Service Géographique de l'Armée*, to reproduce British and French staff-maps, and also by the Librairie Militaire Berger-Lerrault, of Paris, to reproduce some of their maps of the battle areas. In different specialist spheres, the following acted as technical consultants: on Biology and Zoölogy, Dr. Chalmers Mitchell, secretary of the Zoölogical Society of London; on Botany, Prof. F. W. Keeble, of Oxford University; on Mathematics, Prof. G. H. Hardy, of Oxford University; on Aeronautics, Lt.-Col. Mervyn O'Gorman; on Medicine and Surgery, Dr. R. McNair Wilson; on Civil Engineering generally, Mr. H. M. Ross, editor of the *Times Engineering Supplement*; on Electrical Science and Engineering, Prof. J. A. Fleming, of University College, London. Each of the above was responsible for suggesting contributors on the subjects named, and assisted in coördinating their contributions. On military matters Maj. C. F. Atkinson acted for the Editor in obtaining the coöperation of a large number of expert advisers, at home and abroad, and he was responsible for organizing all the articles dealing with military history and equipment. On naval affairs useful advice was given by Rear-Adml. Sir W. Reginald Hall, M.P., and Rear-Adml. H. W. Richmond. Mr. Humbert Wolfe, of the British Ministry of Labour, and Mr. R. Page Arnot, of the unofficial Labour Research Department (the intelligence office of the British Labour movement), assisted from different points of view, in planning the articles dealing with Labour developments, while valuable advice was received on their economic aspects from Sir Hubert Llewellyn Smith and Mr. Sidney Webb. The Editor's thanks are due to all these counsellors; and also to Lord Stamfordham, for material in connexion with the biographical article on King George V., to Sir Godfrey Thomas as regards that on the Prince of Wales, to Sir

Hercules Read for suggestions as to the treatment of Archaeology, and especially to Lord Justice Sir William Younger and Lord Newton, jointly and severally, for their help in securing the undertaking, by their colleague Sir Reginald Acland, K.C., of the article on "Prisoners of War," which represents the first judicial review of the evidence officially taken by Sir William Younger's committee on that subject.

In crediting the editorial staff as a whole with a loyal fellowship which alone rendered possible, by the coöperation of its various departments, the production of the New Volumes in so short a time from their inception, the Editor-in-chief must express his warmest acknowledgment of the services of the three principal assistant-editors in London—Dr. Henry Newton Dickson, D.Sc., formerly professor of Geography at University College, Reading, and Literary Director of the Naval Intelligence Department of the Admiralty during the war; Professor Walter Alison Phillips, Lecky Professor of Modern History at Trinity College, Dublin (who was able to follow up his previous association with the Eleventh Edition, as principal assistant-editor, by devoting his vacations, and such other time as he could spare, to this work); and Mrs. W. L. Courtney (Janet E. Hogarth), who, with an efficient lieutenant in Mrs. Guy Chapman, was in charge of the work done by the ladies who formed part of the staff. Apart from a general participation in headquarters control, Dr. Dickson was especially concerned with the subject-matter of geography and statistics, and with the selection of maps and illustrations, Prof. Alison Phillips with political and constitutional history, and Mrs. Courtney with the biographical articles and those dealing with the Women's Movement, and with the making of the Index, which thus supplements the Index to the Eleventh Edition under the same guiding hand which had been responsible for the great Index to the main body of the work. As Editor's Secretary, keeping touch with all departments, Mr. Arthur Bollaert Atkins also resumed his former rôle, with an efficiency which was invaluable to the editorial organization. The New York branch of the editorial staff, under Mr. Franklin H. Hooper, as American Editor, with Mr. H. R. Haxton and Dr. G. C. Scoggin as his principal assistants, acted in concert throughout with the London office, more particularly in arranging for articles by American contributors or dealing with American affairs. The Editor-in-chief was assured beforehand of the sympathetic and experienced collaboration he enjoyed in this respect by the fact that his editorial association with Mr. F. H. Hooper for such purposes had already been continuous since the year 1900. In seeing the New Volumes finally through the press, he had the advantage of having the combined force of the British and American editorial staffs brought to bear on the critical revision of the work as a whole.

As architect both of the Eleventh Edition and of the superstructure which now converts it into the Twelfth Edition, it has been the present writer's privilege to be served by an international company of practical builders, supplying the world's best available materials and masonry; and he has been inspired by the ambition of cementing and adorning, in the completed edifice, that great movement for Anglo-American coöperation, on whose progress from strength to strength the recovery of civilization after the World War of 1914-9 must so largely depend.

HUGH CHISHOLM.

Christmas 1921.

## ABBREVIATIONS USED IN THESE VOLUMES

### A

**AA.-** Anti-Aircraft: Army Act (British); Automobile Association.

**AA.G.-** Assistant Adjutant-General.

**A.B.C.-** Argentina, Brazil, Chile.

**Abt.-** *Abteilung* = Detachment, sub-unit (German Army).

**ac.-** acre or acres.

**A.C.-** *Artillerie de Campagne, Artillerie de Corps* = Field artillery, Corps artillery — followed by numeral (French).

**A.C.I.-** Army Council Instruction (British).

**A.C. of S.-** Assistant Chief-of-Staff (U.S.A.).

**A.D.-** *Anno Domini* = In the year of our Lord (Latin); *Artillerie divisionnaire* = Divisional artillery (followed by numeral) (French).

**Adml.-** Admiral.

**A.E.F.-** American Expeditionary Force.

**A.F.-** Air Force (British).

**A.F.C.-** Air Force Cross (British).

**A.F.E.F.-** Anglo-French Expeditionary Force.

**A.F.M.-** Air Force Medal (British).

**A.F. of L.-** American Federation of Labor.

**A.G.-** Adjutant-General.

**A.I.D.-** Aircraft Inspection Department (British).

**A.I.F.-** Australian Imperial Force.

**AL.-** *Artillerie Lourde* = Heavy artillery (French).

**Ala.-** Alabama.

**AL.A.M.-** Association of Licensed Automobile Manufacturers.

**AL.G.P.-** *Artillerie Lourde à grande puissance* = Super-heavy artillery (French).

**Als-Lor.-** Alsace-Lorraine.

**AL.V.F.-** *Artillerie Lourde à voie ferrée* = Heavy railway artillery (French).

**A.M.S.-** Army Medical Service.

**ANZAC.-** Australian and New Zealand Army Corps.

**A.O.C.-** Army Ordnance Corps (since 1918 R.A.O.C.).

**A.O.K.-** *Armes-Oberkommando* = Supreme Army Command (Austro-Hungarian); Headquarters of an army, with numeral, e.g. A.O.K. 2 (German).

**A.P.C.-** Army Pay Corps; since 1918 R.A.P.C. (British).

**A.P.D.-** Army Pay Department (British).

**Ariz.-** Arizona.

**Ark.-** Arkansas.

**A.S.C.-** Army Service Corps; since 1926 R.A.S.C. (British).

**A.S.E.-** Amalgamated Society of Engineers.

**A.T.-** *Artillerie de tranchées* = Trench artillery (French).

**A.V.C.-** Army Veterinary Corps since 1918 R.A.V.C. (British).

**A.V.S.-** Army Veterinary Service.

**Az.-** *Aufschlagzünder* = Percussion fuze (German).

### B

**b.-** born.

**Balk. Penin.-** Balkan Peninsula.

**bar.-** barrel or barrels.

**Batt.-** Battery; battalion.

**Bav.-** Bavarian.

**B.C.-** Before Christ.

**Bde.-** Brigade.

**Beds.-** Bedfordshire.

**R.E.F.-** British Expeditionary Force (in particular in France and Belgium).

**Berks.-** Berkshire.

**B.G.-** Brigadier-General, General Staff appointment (British).

**B.H.P.-** Brake Horse-power.

**BL.-** Breech-loading (artillery; as distinct from Q.F.).

**B.M.-** Brigadier-Major (British).

**B.M.A.-** British Medical Association.

**Bn.-** Battalion.

**Brig.-Gen.-** Brigadier-General.

**Bucks.-** Buckinghamshire.

**bus.-** bushel or bushels.

**Bz.-** *Brenzünder* = Time fuze (German).

### C

**c.-** *circa* = round about (Latin).

**C.A.-** *Corps d'Armée* = Army Corps (French).

**C.A.C.-** *Corps d'Armée Coloniale* = Colonial Army Corps (French).

**Cal.-** California.

**Camba.-** Cambridgeshire.

**Capt.-** Captain.

**C.Asia.-** Central Asia.

**Cav.-** Cavalry.

**C.B.E.-** Commander of the Order of the British Empire.

**C.C.-** *Corps de Cavalerie* = Cavalry Corps (French).

**CE.-** *Contre-Espionnage* = Anti-spy service (French).

**C.E.-** Tetronitromethylamine (Tetryl) (Chemical Explosive).

**C.F.-** Chaplain to the Forces (British).

**cf.-** *comfer* = compare (Latin).

**C.G.S.-** Chief of the General Staff (British).

**C.H.-** Companion of Honour.

**Ches.-** Cheshire.

**C.G.T.-** *Confédération Générale du Travail* = General Federation of Labour (French).

**C-in-C.-** Commander-in-Chief (British).

**C.I.D.-** Criminal Investigation Department (British).

**C.I.G.S.-** Chief of the Imperial General Staff (British).

**C.M.-** Court-martial.

**C.M.B.-** Central Midwives Board.

**C.N.-** *Comité Nationale de Secours et d'Alimentation* = National Committee for Relief and Feeding (Belgium).

**co.-** county.

**Co.-** Company.

**C.O.-** Commanding Officer (British).

**C. of S.-** Chief of Staff (U.S.A.).

**Col.-** Colonel.

**Colo.-** Colorado.

**Comm.-** Commander.

**Conn.-** Connecticut.

**Cor.-** Cornwall.

**C.O.S.-** Charity Organization Society (British).

**C.P.-** Centre-pivot (artillery).

**C.R.A.-** Commanding Royal Artillery, i.e. commanding a formation or station (British).

**C.R.A.-** *Commission régulateur automobile* = Motor regulation staff (French).

**C.R.B.-** Commission for Relief in Belgium.

**C.R.E.-** Commanding Royal Engineers, i.e. commanding a formation (British).

**C.r.h. } =** Calibre-radius of head or  
**C.r.o. } =** calibre (artillery);  
**cu. ft. } =** cubic feet.

**Cumb.-** Cumberland.

**C.W.S.-** Co-operative Wholesale Society.

**cwt.-** hundredweight.

### D

**d.-** died; also penny of price.

**D.-** Director (e.g. D.M.O. = Director of Military Operations); as prefix of office-abbreviations = Deputy (e.g. D.D.M.I. = Deputy Director of Military Intelligence).

**D.A.-** *Détachement d'Armée* = Army group (French); Direct Action (fuze); *Direction de l'Armée* = Directorate of the Rear Zone (French). Equivalent to British Chief of C. and American S.O.S.

**D.A.Q.M.G.-** Deputy Assistant Quartermaster-General.

**D.B.E.-** Dame of the Order of the British Empire.

**D.C.-** *Division de Cavalerie* = Cavalry Division (French); District of Columbia.

**D.C.A.-** *Défense Contre Aériens (or Airons)* = Anti-Aircraft Defence (French).

**D.C.M.** = Distinguished Conduct Medal (British).  
**Del.** = Delaware.  
**dept.** = department.  
**D.E.S.** = *Direction d'Etapes et de Services* = Directing staff of a line of communications of an army (French).  
**Dev.** = Devonshire.  
**D.F.C.** = Distinguished Flying Cross (British).  
**D.F.M.** = Distinguished Flying Medal (British).  
**D.G.** = Director-General (e.g. D.G. A.M.S. = Director-General Army Medical Service).  
**D.G.V.O.** = Director-General of Voluntary Organizations.  
**DI.** = *Division d'Infanterie* = Infantry Division (French).  
**DIC.** = *Division d'Infanterie Coloniale* = Colonial Infantry Division (French).  
**Div.** = Division.  
**Dopp.Z.** = *Doppelzunder* = Time and percussion fuze (German).  
**D.O.R.A.** = Defence of the Realm Act (British).  
**D.O.R.E.** = District Officer Royal Engineers (British).  
**Dorset.** = Dorsetshire.  
**D.Q.M.G.** = Deputy Quartermaster-General.  
**DR.** = *Division de Réserve* = Reserve Division (French).  
**D.R.F.** = Depression Rangefinder.  
**D.S.C.** = Distinguished Service Cross (U.S.A. and British).  
**D.S.M.** = Distinguished Service Medal (U.S.A. and British).  
**D.S.O.** = Distinguished Service Order (British).  
**Dur.** = Durham.

**E**

**E.** = East.  
**Ed.** = Editor.  
**E.E.F.** = Egyptian Expeditionary Force.  
**eg.** = *exempli gratia* = for example (Latin).  
**E.M.F.** = Electro-motive force.  
**E.N.E.** = *Éléments non endivisionnés* = Troops not included in divisions ("corps troops" or "army troops") (French).  
**Essex.** = Essex.  
**Esth.** = Esthonia.  
**et seq.** = *et sequentia* = and the following (Latin).

**F**

**F.A.N.Y.S.** = First Aid Nursing Yeomanry Service (British).  
**FEKA.** = *Fernkampfarthillerie* = Super-heavy artillery (German).  
**fg.** = figure or figures (illustration).  
**Fla.** = Florida.  
**FLAK.** = *Flugabwehrkanone* = Anti-aircraft gun (German).  
**F.M.** = Field Marshal; *Fusil Mitrailleur* = French light machine-gun.  
**F.M.L.** = Field-Marshal-Lieutenant (Austro-Hungarian).  
**f.o.b.** = free on board.  
**Fr.Eq.Afr.** = French Equatorial Africa.  
**F.S.R.** = Field Service Regulations (British).  
**ft.** = foot or feet.  
**ft.<sup>2</sup>** = square feet.  
**ft.<sup>3</sup>** = cubic feet.

**fur.** = furlong or furlongs.  
**F.W.D.** = Four-wheel Drive.

**G**

**"G"** = General Staff branch of the Staff, and its functions (British).  
**G.** = Gold.  
**Ga.** = Georgia.  
**G.A.** = *Groupe d'Armées* = Group of Armies (followed by E=Est, N=Nord, etc.) (French).  
**gal.** = gallon or gallons.  
**Gal.** = Galicia.  
**G.A.R.** = Grand Army of the Republic (U.S.A.).  
**G.B.E.** = Grand Cross of the Order of the British Empire.  
**G.d.A.** = *General der Artillerie*  
**G.d.I.** = *General der Infanterie*  
**G.d.K.** = *General der Kavallerie* = "full" general (German and Austro-Hungarian).  
**Gen.** = General.  
**G.H.Q.** = General Headquarters (British and U.S.A.).  
**G.I.G.II, G.III.** = Maintenance, Intelligence and Operation branches; General Staff (U.S.A.).  
**G.Kdo.** = *General-Kommando* = Army corps headquarters (German).  
**Glos.** = Gloucestershire.  
**G.M.T.** = Greenwich Mean Time.  
**G.O.** = *Generaloberst* = General in Command (German).  
**G.O.C.** = General Officer Commanding (British).  
**Gov.** = Governor.  
**G.Q.G.** = *Grand Quartier-Général* = General Headquarters (French Field Armies).  
**gr.** = gramme or grammes.  
**G.R.** = *Gare régulatrice* = Regulating station—rail transport (French).  
**G.S.** = General Staff (British and U.S.A.); General Service (British).  
**G.S.G.S.** = Geographical Section General Staff (British).  
**G.S.O.** = *Gas-Schutz-Offizier* = Anti-gas Officer (German).  
**G.S.O.1,2,3** = General Staff Officer, 1st, 2nd and 3rd grade (British).  
**G.V.C.** = *Gardes des Voies de Communication* = Line-of-Communication defence troops (French).

**H**

**H.** = *Honvéd* (as prefix in Austro-Hungarian designations); "Heure" = Zero hour, hour set for attack (French).  
**H.A.** = Heavy Artillery; less frequently, horse artillery; high-angle (gun).  
**Hants.** = Hampshire.  
**H.E.** = High Explosive.  
**Hereford.** = Herefordshire.  
**Herts.** = Hertfordshire.  
**H.G.** = *Heeresgruppe* = Group of armies (German).  
**hhd.** = hogshead or hogsheads.  
**H.M.S.** = His Majesty's Ship (British).  
**H.Q.** = Headquarters (British and U.S.A.).  
**H.Qu.** = *Hauptquartier* = Headquarters (German).  
**H.P.** = Horse-power.  
**H.R.** = *Hors rang* = Supernumerary (French Army).

**Hants.** = Huntingdonshire.  
**H.T.** = Horse Transport.  
**H.V.** = High Velocity (gun).

**I**

**I.** = *Instantané* = Instantaneous (in French fuze designations); Island.  
**Ia.** = Iowa.  
**I.A.** = *im Auftrage* = By order, on behalf of (German).  
**I.A.** = Indian Army.  
**ib. pr. ibid.** = *ibidem* = in the same place (Latin).  
**I.D.** = *Infanterie-Division* = Infantry Division (German).  
**I.e.** = *id est* = that is (Latin).  
**I.H.P.** = Indicated Horse-power.  
**Ill.** = Illinois.  
**ILL.P.** = Independent Labour Party (British).  
**in.** = inch or inches.  
**in.<sup>2</sup>** = square inches.  
**in.<sup>3</sup>** = cubic inches.  
**Ind.** = Indiana.  
**Inf.** = Infantry.  
**Is.** = Islands.  
**I.W.W.** = Industrial Workers of the World.

**J**

**"J"** = "Jour" = "Zero day" fixed for attack (French).  
**J.C.A.** = Jewish Colonization Association.

**K**

**K.** = *Königlich* = Royal, or *Kaiserlich* = Imperial (German).  
**Kan.** = Kansas.  
**K.B.E.** = Knight Commander of the Order of the British Empire.  
**K.D.** = *Kavallerie-Division* = Cavalry Division (German).  
**kgm.** = kilogram or kilograms.  
**K.K.** = *Kaiserlich-Königlich* = Imperial-Royal (Austrian Landwehr).  
**km.** = kilometre or kilometres.  
**K.R.** = King's Regulations (British Army).  
**K.T.D.** = *Kavallerie-Truppendivision* = Cavalry Division (Austro-Hungarian).  
**K.u.K.** = *Kaiserlich und Königlich* = Imperial and Royal (Austrian and Hungarian designation of common army).  
**kw.** = kilowatt or kilowatts.  
**Ky.** = Kentucky.

**L**

**L.** = *Landwehr* (German and Austrian).  
**La.** = Louisiana.  
**Latv.** = Latvia.  
**lb.** = pound or pounds.  
**Lanca.** = Lancashire.  
**L.C.C.** = London County Council.  
**Ldat.** = *Landsturm* (Austro-Hungarian and German).  
**Lith.** = Lithuania.  
**L.M.G.** = *Leichtes Maschinengewehr* = Light machine-gun (German).  
**L. of C.** = Line of communications (British).  
**Leics.** = Leicestershire.  
**Lincs.** = Lincolnshire.  
**Lt.** = Lieutenant.  
**Lt-Comm.** = Lieutenant-Commander.  
**Lt-Gen.** = Lieutenant-General.

**M**

**m.** = mile or miles.  
**Maj.** = Major.  
**Maj.-Gen.** = Major-General.  
**Mass.** = Massachusetts.  
**M.B.E.** = Member of the Order of the British Empire.  
**M.C.** = Military Cross (British); Master of Chemistry.  
**Md.** = Maryland.  
**Mdx.** = Middlesex.  
**Me.** = Maine.  
**Mebd.** = *Maschinengewehr-Eisenbeton-maschinengewehr* = Reinforced concrete machine-gun emplacement (German).  
**M.E.F.** = Mediterranean Expeditionary Force (British 1915-7).  
**Mesop.** = Mesopotamia.  
**M.G.** = Machine-gun (heavy implied, as a rule).  
**M.G.A.** = Major-General in charge of administration, regional commands (British).  
**M.G.C.** = Machine-gun Corps.  
**M.G.G.S.** = Major-General, General Staff of an Army (British).  
**Mg.H.** = *Mit geschrankter Haftung* = With limited liability (German).  
**M.G.K.** = *Maschinengewehr-Kompanie* = Machine-gun Company (German).  
**M.G.O.** = Master-General of the Ordnance (British).  
**M.I.** = Military Intelligence; formerly also Mounted Infantry (British).  
**Mich.** = Michigan.  
**Minn.** = Minnesota.  
**Miss.** = Mississippi.  
**M.L.** = Muzzle-loading.  
**M.M.** = Military Medal (British).  
**M. of M.** = Ministry of Munitions (British).  
**Mo.** = Missouri.  
**Mon.** = Monmouthshire.  
**Mont.** = Montana.  
**M.S.** = Military Secretary.  
**M.T.** = Mechanical Transport.  
**m.V.** = *mit Verzögerung* = Delay-action fuze (German).  
**MW.** = *Minenwerfer* = Trench Mortar (German).

**N**

**N.** = North.  
**N.A.C.B.** = Navy and Army Canteen Board (British).  
**N.Af.** = North Africa.  
**N.Am.** = North America.  
**N.C.** = North Carolina.  
**N.C.T.** = Nitro-cellulose. Tubular.  
**N.D.** = North Dakota.  
**Neb.** = Nebraska.  
**Nev.** = Nevada.  
**N.H.** = New Hampshire.  
**N.H.P.** = Nominal Horse-power.  
**N.I.D.** = Naval Intelligence Division (British).  
**N.J.** = New Jersey.  
**N.M.** = New Mexico.  
**Nor.** = Norway.  
**Norf.** = Norfolk.  
**Northants.** = Northamptonshire.  
**Northumb.** = Northumberland.  
**N.O.T.** = Netherlands Overseas Trust.  
**Notts.** = Nottinghamshire.  
**N.S.** = Gregorian, or new style, Calendar (see 4.994).  
**N.U.R.** = National Union of Railwaymen (British).  
**N.U.S.E.C.** = National Union of Societies for Equal Citizenship (British).

**N.U.W.S.S.** = National Union of Women's Suffrage Societies (British).  
**N.U.W.W.** = National Union of Women Workers (British).  
**N.Y.** = New York.  
**O.** = Ohio.  
**O.B.E.** = Officer of the Order of the British Empire.  
**O.C.** = Officer Commanding (British).  
**O.H.L.** = *Oberste Heeresleitung* = Supreme Army Command (German).  
**Okl.** = Oklahoma.  
**Ore.** = Oregon.  
**O.S.** = Ordnance Survey (British); Julian, or old style, Calendar (see 4.994).  
**O.T.C.** = Officers' Training Corps.  
**o.V.** = *ohne Verzögerung* = Direct-action fuze (German).  
**Oxon.** = Oxfordshire.  
**oz.** = ounce or ounces.

**P**

**P.** = Percussion (fuze).  
**Pa.** = Pennsylvania.  
**P.A.** = *Pour ampliation* = Authorized for issue of documents (French Army).  
**P.C.** = *Poste de Commandement* (French Army); Post of Command (U.S.A.) = battle or advanced headquarters (British).  
**P. et Cv.** = *Parcs et Convóis* = Trains and columns (French Army).  
**P.O.** = *Par ordre* = By order; by command (French); Post Office.  
**Pol.** = Poland.  
**pop.** = population.  
**P.R.** = *Poste-retard* = Delay-action fuze (French).  
**Pr.** = Pounder (Gun designation).  
**Pres.** = President.  
**Prof.** = Professor.  
**pt.** = pint or pints.  
**P.V.** = *Pigeon voyageur* = Carrier-pigeon (French).

**Q**

**Q.A.I.M.N.S.** = Queen Alexandra's Imperial Military Nursing Service (British).  
**Q.A.M.F.N.S.** = Queen Alexandra's Military Families Nursing Service (British).  
**Q.A.R.N.N.S.** = Queen Alexandra's Royal Naval Nursing Service (British).  
**Q.F.** = Quickfiring (artillery).  
**Q.G.** = *Quartier Général* = Headquarters (French).  
**Q.G.A2** = Headquarters of the II. Army (French).  
**Q.M.A.A.C.** = Queen Mary's Army Auxiliary Corps (W.A.A.C.) (British).  
**Q.M.G.** = Quartermaster-General.  
**Q.M.N.G.** = Queen Mary's Needlework Guild (British).  
**qr.** = quarter or quarters.  
**qt.** = quart or quarts.  
**q.v.** = *quod videt* = which see (Latin), for reference.

**R**

**R.** = Reserve (in troop designations).  
**R.A.** = Royal Artillery (British).  
**R.A.C.** = Royal Automobile Club (British).

**R.A.F.** = Royal Air Force (British).  
**R.A.M.C.** = Royal Army Medical Corps (British).  
**R.A.O.C.** = Royal Army Ordnance Corps (British).  
**R.A.S.C.** = Royal Army Service Corps (British).  
**R.C.S.** = Royal Corps of Signals, since 1919 (British).  
**R.D.** = *Rive Droite* = Right bank (of a river) (French).  
**R.E.** = Royal Engineers (British).  
**Regt.** = Regiment.  
**Res.** = Reserve.  
**R.F.A.** = Royal Field Artillery (British).  
**R.F.C.** = Royal Flying Corps (British).  
**R.G.** = *Rive Gauche* = Left bank (of a river) (French).  
**R.G.A.** = Royal Garrison Artillery (British).  
**R.H.A.** = Royal Horse Artillery (British).  
**R.I.** = Rhode Island.  
**R.I.B.A.** = Royal Institute of British Architects.  
**R.I.C.** = Royal Irish Constabulary.  
**R.M.** = Royal Marines (British).  
**R.M.A.** = Royal Military Academy (Woolwich); Royal Marine Artillery (British).  
**R.M.C.** = Royal Military College (England).  
**R.M.L.I.** = Royal Marine Light Infantry (British).  
**R.N.** = Royal Navy (British).  
**R.N.A.F.** = Royal Naval Air Force (British).  
**R.N.A.S.** = Royal Naval Air Service (British).  
**R.N.R.** = Royal Naval Reserve (British).  
**R.N.V.R.** = Royal Naval Volunteer Reserve (British).  
**ro.** = road.  
**ru.** = rupa.  
**R.O.D.** = Railway Operating Division (British Army in France).  
**R.P.** = Rules of Procedure (British Military Law).  
**R.T.O.** = Railway Transport Officer (British and U.S.A.).  
**Rutl.** = Rutland.  
**R.W.** = Royal Warrant (for pay, etc.) (British).

**S**

**S.** = South.  
**s.** = shilling or shillings.  
**S.A.E.** = Society of Automobile Engineers.  
**Salop.** = Shropshire.  
**S.C.** = South Carolina.  
**S.D.** = South Dakota.  
**seq.** = *sequens, sequentia* = the following (Latin).  
**Sil.** = Silesia.  
**S.M.O.** = Senior Medical Officer of a formation or station (British).  
**S.M.T.O.** = Senior Mechanical Transport Officer of a formation (British).  
**Som.** = Somersetshire.  
**S.O.S.** = Services of Supply, Rear Zone (U.S.A.), equivalent to British L. of C.; also wireless call for life-saving.  
**S.P.R.** = Society for Psychological Research.  
**S.P.V.D.** = Society for Prevention of Venereal Disease.  
**Sq.** = Squadron.  
**sq.ft.** = square feet.  
**S.R.** = *Sans retard* = Direct-action (of fuze).



INITIALS USED IN VOLUME XXX. TO IDENTIFY CONTRIBUTORS,  
WITH THE HEADINGS OF THE ARTICLES TO WHICH  
THESE INITIALS ARE SIGNED.

A. B.	ANTON BETTELHEIM, DR. JURIS.	{ Austrian Empire: Literature and Drama.
A. C. D.	ALFRED C. DEWAR, CAPT. R.N. (MST.), B. LITT. (ONOR.). Gold Medalist, Royal United Service Institution. Late of the Historical Section, Naval Staff, Admiralty.	{ Admiralty Administration: British; Blockade; Convoy; Colonel; Dogger Bank.
A. D. H.	SIR ALFRED DANIEL HALL, K.C.B., M.A., LL.D., F.R.S. Chief Scientific Adviser and Director-General of the Intelligence Department, Ministry of Agriculture and Fisheries. Author of <i>The Soil; Fertilisers and Manures; A Pilgrimage of British Farming; Agriculture after the War;</i> etc.	{ Agriculture.
A. E. EV.	ARTHUR ERNEST EVEREST, D.Sc., PH.D., F.I.C. Joint-author of <i>The Natural Organic Colouring Matters</i> (Perkin and Everest). Author of various papers on Colouring Matters, etc., in <i>Proc. Roy. Soc., Journ. Chem. Soc.</i> , etc.	{ Botany: Chemistry of Sap Pigments of Plants.
A. FL.	ALEXANDER FLEMING, M.B., F.R.C.S. Director of the Department of Systematic Bacteriology in St. Mary's Hospital, London.	{ Antiseptics.
A. F. FR.	ALFRED FRANCIS FRIBRAM, PH.D. Professor of Modern History in the University of Vienna. Member of the Vienna Academy of Science; etc.	{ Aehrenthal; Austrian Empire: Austro- Hungarian Foreign Policy; Berchtold, Count L.; Burián, R. S. von; Charles (Emperor of Austria); Czernin, Count.
A. G. L.	ALFRED GOODMAN LEVY, M.D., M.R.C.P. Physician to the City of London Hospital for Diseases of the Chest.	{ Anaesthetics.
A. G. W.	ADAM GOWANS WHYTE, B.Sc., A.I.E.E. Editor of the <i>Electrical Press Limited</i> . Author of <i>The Electrical Industry; Electricity in Locomotion; The All-Electric Age</i> .	{ Electricity Supply: United Kingdom.
A. H. BR.	ALFRED H. BROOKS, B.Sc., D.Sc. Geologist, U.S. Geological Survey. In charge of geologic and topographic surveys and investigations of mineral resources of Alaska. Vice-Chairman of the first Alaska Railroad Commission.	{ Alaska.
A. H. C.*	A. H. CHRISTIE. Late Director, Westminster Technical Institute.	{ Arts and Crafts (in part).
A. H. CH.	ARTHUR HARRY CHURCH, M.A., D.Sc. University Lecturer in Botany, Oxford.	{ Botany: General Morphology.
A. H. GI.	ARNOLD HARTLEY GIBSON, D.Sc., M.INST.C.E., M.I.MECH.E., F.R.A.S. Professor of Engineering, University of Manchester; late Professor of Engi- neering, St. Andrews University. Member, Board of Trade Water Power Committee; Hon. Secretary, Conjoint Board, Water Power Committee. Member of the Air Ministry I.C.E. Committee. President, British Association, Section 6/1921.	{ Aeronautics: Aero-Engines.

A complete list, showing all contributors to the New Volumes (arranged according to the alphabetical order of their surnames) with the articles signed by them, appears at the end of Volume XXXII.



- A. H. McM.** COLONEL SIR ARTHUR HENRY M'MAHON, G.C.M.G., G.C.V.O., K.C.I.E., C.S.I., F.S.A., F.L.S., etc.  
Foreign Secretary to the Government of India, 1911-4. British High Commissioner in Egypt, 1914-6. See biographical article: M'MAHON, SIR ARTHUR HENRY. } **Afghanistan.**
- A. J. G.** REV. ALEXANDER JAMES GRIEVE, M.A., D.D.  
Principal and Professor of Systematic Theology in the Scottish Congregational College, Edinburgh. Assistant Editor of *Peake's Commentary on the Bible*. } **Church History: Free Churches: Presbyterian Church of Scotland.**
- A. J. M.** SQUADRON LEADER ARNOLD JOHN MILEY, O.B.E., R.A.F.  
Design Branch, Directorate of Research, Air Ministry, in charge of Seaplane Development. Assistant Director, Air Department, Admiralty, June 1915 to June 1916; Senior Flying Officer Naval Air Station, Felixstowe, August 1916 to June 1917. } **Aeronautics: Seaplanes.**
- A.-K.** GENERAL MORITZ AUFFENBERG-KOMAROW  
See the biographical article: AUFFENBERG-KOMAROW, MORITZ. } **Army: Austro-Hungarian (in part); Beck, Graf von; Conrad von Hüttenborg.**
- A. L. Bo.** ARTHUR LYON BOWLEY, Sc.D.  
Professor of Statistics in the University of London. Author of *Elements of Statistics*; *Wages in the United Kingdom*; etc. } **Cost of Living.**
- A. L. C.** COLONEL ARTHUR LATHAM CONGER, U.S. ARMY.  
Distinguished Service Medal (U.S.A.), C.M.G. Legion of Honour. Formerly co-editor of *The Military Historian and Economist*. } **Army: United States; Champagne, Battles in (in part).**
- A. P.** SIR ARTHUR PEARSON, Bt., G.B.E. (died 1921).  
Chairman of the Blinded Soldiers and Sailors Care Committee. President of the National Institute for the Blind. Author of *Victory over Blindness*; *The Conquest of Blindness*. See the biographical article: PEARSON, SIR ARTHUR. } **Blindness.**
- A. S. D.** AUGUSTUS SEISS DOWNING, A.B., M.A., L.H.D., LL.D.  
Assistant Commissioner for Higher Education and Director of Professional Education, University of the State of New York. } **Education: United States (in part).**
- A. S. E.** ARTHUR STANLEY EDDINGTON, M.A., M.Sc., F.R.S.  
Plumian Professor of Astronomy and Experimental Philosophy and Director of the Observatory, Cambridge. Author of *Stellar Movements and the Structure of the Universe*; *Space, Time and Gravitation*. } **Astronomy.**
- B. B.-H.** MAJOR-GENERAL BASIL FERGOUSON BURNETT-HITCHCOCK, C.B., D.S.O., F.B.C.  
Director-General of Mobilization and Recruiting, War Office. } **Army: British.**
- B. E. P.** GENERAL OF BRIGADE BARTHÉLEMY EDMOND PALAT.  
Late French Army. Commanded a Division 1915-6. Author of *La Grande Guerre sur le front Occidental*; *Les Batailles d'Artois et de Champagne*; and, under the pseudonym "Pierre Lebaud court," of *La Defense Nationale, 1870-1* and other works, including a general bibliography of 1870-1. } **Champagne, Battles in (in part).**
- B. E. L.** BASIL KENNETH LONG.  
Editor of the *Cock's Times*. Formerly Foreign Editor of *The Times*. } **Bohin, General.**
- B. W. D.** BRIAN WESTERDALE DOWNS, M.A.  
Fellow and Lecturer in Medieval and Modern Languages and English, Christ's College, Cambridge. } **Cambridge.**
- C. A. D.** CLYDE AUGUSTUS DUNIWAY, Ph.D., LL.D.  
President of Colorado College, Colorado Springs, Colo. Author of *Freedom of the Press in Massachusetts*. } **Colorado.**
- C. Br.** CARL BROCKHAUSEN, DR. JURIS.  
Professor of the Science of Administration in the University of Vienna. } **Austrian Empire (in part); Baden, K.**
- C. B. C.** WING COMMANDER T. R. CAVE-BROWNE-CAVE, C.B.E., R.A.F., F.R.A.E.S., A.M.I.MECH.E., A.M.I.N.A.  
In charge of Airship Experiments and Research at the Admiralty and the Air Ministry. Lecturer in Airship Engineering, Imperial College of Science. Airship Member of the Aeronautical Research Committee. Formerly Engineer Officer, R.N. Airship Pilot, 1913. In charge of Non-rigid Airship Design and Construction at Kingsnorth, 1914-8. } **Aeronautics: Airships.**
- C. C. H.** CHARLES CAESAR HAWKINS, M.A., M.I.E.E., ASSOC. AMERICAN I.E.E.  
Author of *The Dynamo*. Joint-author of *Papers on the Design of Alternate Current Machinery*. } **Electrical Engineering (in part).**
- C. E. C.** MAJOR-GENERAL SIR CHARLES EDWARD CALLWELL, K.C.B.  
Director of Military Operations, War Office, 1914-6. Author of *Small Wars*; *Military Operations and Maritime Preponderance*; *The Dardanelles*; etc. } **Dardanelles Campaign.**
- C. E. W. B.** MAJOR CLAUDE EAGLES WILLOUGHBY BEDDOES, O.B.E.  
Gloucestershire Regiment. Inspector of Grenade Training, G.H.Q., Great Britain, 1915-8. Experimental Officer for Grenades and Trench Stores, Ministry of Munitions, 1918-9. Control Officer, Inter-Allied Commission of Control, 1919. } **Dogs, War (in part).**



INITIALS AND HEADINGS OF ARTICLES

E. C. K.	EDWARD CAMERON KIRK, D.D.S., Sc.D., LL.D. Late Dean and Emeritus Professor of Dental Pathology and Therapeutics, Dental School, University of Pennsylvania. Editor of <i>The Dental Cosmos</i> .	Dentistry.
E. F. R. O.	ELINOR F. B. GROGAN (Lady Grogan). Wife of Colonel Sir Edward Grogan, Bart., C.M.G., D.S.O. Travelled and lived for some years in the Balkans. Author of articles on Balkan subjects in the <i>Nineteenth Century</i> ; <i>New Europe</i> ; etc.	Bulgaria.
E. F. I.	EDWARD E. LAW. Consulting Engineer. Formerly of the Armour Plate Department, Armstrong Whitworth & Co.	Armour Plate.
E. G.-H.	MAJOR EDUARD GLAISE-HORSTENAU. Late General Staff, Austro-Hungarian Army. Now of the Kriegsarchiv, Vienna. Formerly Staff Officer to Field-Marshal Conrad von Hötzenndorf.	Austria, Republic of: <i>History</i> ; Eastern European Front Campaigns ( <i>in part</i> ). Army: <i>Austro-Hungarian (in part)</i> ; Brest Litovsk, Battles round, 1915; Dunajec-San, Battles of the
E. J.	MAJOR ERNST JOLY. Late General Staff, Austro-Hungarian Army. Now of the Kriegsarchiv, Vienna. Part-author of the Austrian Official <i>War Chronology Tables</i> , etc.	
E. J. F.	EDGAR JOHN FORSDYKE, M.A., F.S.A. Assistant in the Department of Greek and Roman Antiquities in the British Museum. Editor of the <i>Journal of Hellenic Studies</i> .	Archaeology: <i>Greece</i> .
E. J. G.	EDGAR JOHNSON GOODSPEED, Ph.D. Professor of Biblical and Patristic Greek, and Secretary to the President, Chicago University. Author of the <i>Story of the New Testament</i> ; <i>Index Patristicus</i> ; and Contributor to the <i>Atlantic Monthly</i> .	Chicago, University of.
E. J. R.	EDWARD JOHN RUSSELL, D.Sc., F.R.S. Director of the Rothamsted Experimental Station. Author of <i>Soil Conditions and Plant Growth</i> ; <i>The Fertility of the Soil</i> ; <i>Lessons on Soil</i> ; <i>Manuring for Higher Crop Production</i> ; etc.	Botany: <i>Soil Sterilization</i>
E. J. S.	EDWARD JAMES SALISBURY, D.Sc., F.L.S. Lecturer in Botany and Fellow of University College, London. Hon. Secretary, British Ecological Society. Author of <i>An Introduction to the Study of Plants</i> ; etc.	Botany: <i>Ecology</i> .
E. K.	EDMUND KNECHT, Ph.D. (Zürich), M.Sc. Tech., F.I.C. Associate Professor of Applied Chemistry, Manchester University and College of Technology.	Dyeing: <i>United Kingdom</i> .
E. M. Ho	ERNEST MARTIN HOPKINS, A.M., Litt.D., LL.D. President of Dartmouth College, Hanover, N.H.	Dartmouth College.
E. M. S.	BREVET CORONEL ERNEST NORMAN STOCKLEY, D.S.O. Royal Engineers.	Bridging, Military.
E. S.	ERNEST SANDFORD. Secretary to the Lord Mayor of Birmingham. Joint-author (with R. H. Brazier) of <i>Birmingham and the Great War</i> .	Birmingham.
E. S. H.	ELIZABETH SANDERSON HALDANE, C.H., LL.D., J.P. Member of Education Authority for Perthshire. Vice-Chairman, Territorial Force Nursing Service Committee. On Royal Commission on the Civil Service. Member of the Scottish Universities Committee. Author of <i>The Life of Descartes</i> ; etc.	Child Welfare: <i>United Kingdom</i> .
E. S. H.*	CAPTAIN EDGAR STOPPORD HOLLAND. Late Royal West Kent Regiment. Formerly Mobilization Directorate, War Office. Member of Gray's Inn.	Army: <i>British, Demobilization</i> ; <i>Dogs, War (in part)</i> .
E. S. S.	ERNEST STANLEY SALMON, F.L.S. Reader in Economic Mycology, University of London. Mycologist to the South-Eastern Agricultural College, Wye, Kent.	Botany: <i>Mycology</i> .
E. V. V.	ERNEST VANCOURT VAUGHN, M.A., Ph.D. Professor of History in the University of Delaware. Author of <i>The Origin and Early Development of the English Universities to the Close of the 13th Century</i> ; <i>English Trading Expeditions into Asia under Authority of the Muscovy Company, 1557-81</i> .	Delaware.
E. v. W.	EDUARD VON WERTHEIMER. Emeritus Professor of History in the University of Pressburg.	Andrassy, J. J.
E. W. MacB.	ERNEST WILLIAM MACBRIDE, D.Sc. (Lond.), M.A. (Cantab.), Hon. LL.D. (McGill). F.R.S. Vice-President of the Zoological Society of London. Vice-Chairman of the Eugenica Education Society. Formerly Professor of Zoology in McGill University, Montreal. Professor of Zoology in the Imperial College of Science and Technology, London. Author of <i>Textbook of the Embryology of the Invertebrata</i> ; etc.	Cytology; Embryology
F. A. Cl.	FREDERICK ALBERT CLEVELAND, Ph.B., Ph.D., LL.D. Professor of United States Citizenship, Maxwell Foundation, Boston University. Author of <i>Organized Democracy</i> ; <i>First Lessons in Finance</i> ; etc.	Boston.

# INITIALS AND HEADINGS OF ARTICLES

xviii

F. A. L.	FREDERICK ALEXANDER LINDEMANN, M.A., Ph.D., F.R.S. Professor of Experimental Philosophy in the University of Oxford.	Einstein, A.
F. C.-O.	CAPTAIN FRANK CREAGH-OSBORNE, R.N., C.B. Director, Admiralty Compass Department.	Compass.
F. C. E.	FRANK CARL ENDRES. Major, late General Staff, Turkish Army. Author of a <i>Life of Molke; Die Ruine des Orients</i> ; etc. Member of Committee, German League of Nations Union.	Army: Turkish; Balkan Wars (in part).
F. E.	FRANK FOX, O.B.E. Author of <i>Australia; Problems of the Pacific</i> ; "G.H.Q." Served in the World War as Artillery officer and as Staff officer.	Australia; Canton.
F. G. B.	FRANK GEORGE BARNES. Superintendent, Homerton Residential School for the Deaf. Formerly Editor of <i>The Teacher of the Deaf</i> . Officer of the French Academy.	Deaf and Dumb.
F. G.-T.	R. GLOVERFELD-TARP, M.A. Chief Secretary to the Danish Extraordinary Commission on Regulation of Prices. Secretary to the General Director of the Great Northern Telegraph Company (Store Nordiske).	Denmark (in part).
F. H. Br.	FRANK HERBERT BROWN, C.I.E. On the Staff of <i>The Times</i> for Indian Affairs. London Correspondent of <i>The Times of India</i> . Formerly Assistant Editor of the <i>Bombay Gazette</i> and Editor of the <i>Indian Daily Telegraph</i> , Lucknow.	Aga Khan; Bikaner, Maharaja of.
F. I.	FLORENCE IRWIN. Author of <i>The Complete Auction Player; Master-Auction</i> ; etc.	Bridge, Auction.
F. J. C. W.	MAJOR F. J. C. WYATT, O.B.E., M.C. Royal Engineers. Organizer and Controller of Camouflage, British Expeditionary Force, France, 1916-8.	Camouflage: Military.
F. Ke.*	FREDERICK WILLIAM KEEBLE, C.B.E., F.R.S. Sherardian Professor of Botany in the University of Oxford.	Botany: Introductory.
F. L. N.	COLONEL SIR FREDERIC LEWIS NATHAN, K.B.E. Late Royal Artillery. Department of Scientific and Industrial Research. Director of Alcohol Section, Fuel Research Board.	Alcohol.
F. M. R.	LIEUTENANT-COLONEL F. M. RICKARD. Royal Artillery. Chief Instructor, Artillery College, Woolwich (assisted by Instructional Staff, Artillery College).	Ammunition (in part).
F. R. C.	FRANK RICHARDSON CANA, F.R.G.S. Editorial Staff, 11th edition of the <i>Encyclopædia Britannica</i> . Editorial Staff of <i>The Times</i> . Author of <i>South Africa from the Great Trek to the Union; Problems of Exploration; Africa; The Sahara in 1915; The Great War in Europe</i> ; etc.	Abyssinia; Africa; Angola; Belgian Congo; Cairo; Cameroon; Cape Province; Dahomey; Delagoa Bay; East African Military Operations; Egypt (in part)
F. W. E.-G.	FREDERICK WILLIAM EDRIDGE-GREEN, C.B.E., M.D., F.R.C.S. Special Examiner and Adviser to the Board of Trade on Colour Vision and Eyesight. Author of <i>The Physiology of Vision</i> . Inventor of the Colour Perception Spectrometer and Colour Perception Lantern—used as the Official Test of the British Navy.	Colour Vision and Colour Blindness.
F. W. P.	FLOYD W. PARSONS, E.M. Founder and former Editor of <i>The Coal Age</i> .	Coal: United States.
F. Y.	ALEXANDER BELL FILON YOUNG. Editor of the <i>Saturday Review</i> . Author of <i>With the Battle Cruisers; Master-singers; Ireland at the Cross Roads; Christopher Columbus and the New World; The Sands of Pleasure; When the Tide Turns</i> ; etc.	Beatty, Lord.
F. Z.	F. ZEUTHEN.	Denmark (in part).
G. A.	GEORGE JEFFREYS ADAM, Formerly Correspondent of <i>The Times</i> in Paris.	Briand, A. Deschanel, P.
G. Ab.	GRACE ABBOTT, M.A. Chief of the Children's Bureau, U.S. Department of Labor. Formerly Director Child Labor Division, U.S. Children's Bureau, and Executive Secretary, Rhinoceros Immigrants Commission, Chicago.	Children, Laws Relating to: United States, Child Welfare: United States.
G. A. Y.	GILBERT A. YOUNGBERG, D.S.O. Lieutenant-Colonel, Corps of Engineers, Assistant to the Chief of Engineers, U.S. Army.	Engineers, Military: United States.
G. C.	G. CASTELLANO. Author of <i>Introduzioni allo studio delle opere di B. Croce</i> (1920).	Croce, Benedetto (in part).
G. E. B.	GEORGE EARLE BUCKLE, M.A., Hon. LL.D. Formerly Scholar of New College and Fellow of All Souls College, Oxford. Editor of <i>The Times</i> , 1884-1912. Author of <i>Life of Disraeli</i> (vols. 3, 4, 5, and 6). See biographical article: BUCKLE, GEORGE EARLE.	Asquith, H. H.; Balfour, A. J.; Carson, Sir Edward; Cecil, Lord Hugh; Cecil, Lord Robert; Churchill, Winston; Chamberlain, English History: 1913-21.

G. E. M.	SIR GEORGE ERNEST MAY, K.B.E., F.I.A. Secretary of the Prudential Assurance Company Limited. Manager to the Dollar Securities Committee.	Dollar Securities Mobilization.
G. E. S.	GRAFTON ELLIOT SMITH, M.A., M.D., F.R.C.P., F.R.S. Professor of Anatomy in the University of London. Author of <i>The Ancient Egyptians; The Royal Mummies; Migrations of Early Culture; Evolution of the Dragon, etc.</i>	Anthropology.
G. K. S.-M.	MAJOR-GENERAL SIR GEORGE KENNETH SCOTT-MONCRIEFF, K.C.B., K.C.M.G., C.I.E., HON. M. INST. C.E., LATE R.E. Director of Fortifications and Works, War Office, 1911-8. Author of <i>The Water Supply of Barracks and Cantonments; The Principles of Structural Design; etc.</i>	Barracks and Hutments; Engineers, Military; United Kingdom.
G. P.	GUYFORD PINCHOT, A.B. (Yale), HON. A.M. (Yale and Princeton), ST.D. (Michigan Agricultural College), LL.D. (McGill). Professor of Forestry, Yale University. U.S. Forester, 1898-1910. President of the National Conservation Association. Pennsylvania Commissioner of Forestry. Author of <i>The Adirondack Spruce; The Training of a Forester; The Fight for Conservation; etc.</i>	Conservation Policy.
G. S.	GEORGE SAUNDERS, O.B.E., B.A. (Oxon.), HON. LL.D. (Glasgow). Correspondent of the <i>Morning Post</i> in Berlin, 1888-97; and of <i>The Times</i> in Berlin, 1897-1908, and in Paris, 1908-14.	Bethmann-Hollweg, T. von; Bülow, Prince von; Delbrück, Hans; Eisner, Kurt.
G. S. F.	GUY STANTON FORD, PH.D. Professor of History and Dean of the Graduate School, University of Minnesota. Director of Division of Educational and Civic Publications, Committee on Public Information.	Censorship: United States.
G. T.*	GEOFFREY TOVE. Scholar and Exhibitor, Royal College of Music. Author of <i>Extempore Morris Dance Book</i> , No. 2. Conductor, Philharmonic Societies, London and Liverpool.	Dancing.
H. A. B.	BRIGADIER-GENERAL HENRY ARTHUR BETHELL, C.M.G. Late Royal Field Artillery. Author of <i>Modern Guns and Gunnery; Modern Artillery in the Field.</i>	Artillery (in part).
H. A. H.	HOWARD ARCHBALD HUBBARD, M.A. Associate Professor of History and Social Science in the University of Arizona.	Arizona.
H. Ch.	HUGH CHISHOLM, M.A. Formerly Scholar of Corpus Christi College, Oxford. Editor of the 10th, 11th and 12th editions of the <i>Encyclopædia Britannica</i> . Financial Editor of <i>The Times</i> , 1913-20. See the biographical article: CHISHOLM, HUGH.	English History: 1910-2.
H. Cl.	SIR HUGH CLIFFORD, G.C.M.G. Governor of Nigeria. In the Federated Malay States Civil Service, 1883-1903; in the West Indies, 1903-7; in Ceylon, as Colonial Secretary, 1907-12. Governor of the Gold Coast, 1912-6. Administered the British Sphere of Occupation in Togoland throughout the World War. Author of <i>Studies in Brown Humanity; Further India; The German Colonies; etc.</i>	Ashanti.
H. Cr.	HOMER CROY. Author of <i>How Motion Pictures Are Made.</i>	Cinematograph.
H. E. A.	HENRY EDWARD ARMSTRONG, PH.D., LL.D., D.Sc., F.R.S. Emeritus Professor of Chemistry at the City and Guilds College, South Kensington. Davy Medallist of the Royal Society, 1911.	Chemistry.
H. E. A. C.	HENRY EVAN AUGUSTE COTTON, C.I.E., L.C.C. Formerly Scholar of Jesus College, Oxford, and Advocate of the High Court at Calcutta. Author of <i>Calcutta Old and New</i> . Late Editor of <i>India</i> .	Banerjee, Sir S.
H. E. B.	HENRY ELDRIDGE BOURNE, L.H.D. Professor of History in Western Reserve University, Cleveland, Ohio. Author of <i>The Revolutionary Period in Europe; The Teaching of History and Civics; etc.</i>	Cleveland.
H. E. Eg.	HUGH EDWARD EGERTON. Sometime Beit Professor of Colonial History, Oxford. Fellow of All Souls College, Oxford. Author of <i>A Short History of British Colonial Policy; Origin and Growth of the English Colonies; "Canada" (Part II.)</i> in Sir Charles Lucas's <i>History and Geography of the British Colonies; etc.</i>	British Empire.
H. E. Wl.	MAJOR H. E. WIMPERIS, O.B.E., M.A., M.I.E.E., A.M.I.C.E., F.R.A.E.S. Superintendent of the Air Ministry Laboratory. Lecturer on Air Navigation at the Imperial College of Science. Served in Royal Air Force.	Aeronautics: Air Navigation.
H. G. J.	HERMAN GERMACH JAMES, M.A., J.D., PH.D. Professor of Government in the University of Texas. Author of <i>Principles of Prussian Administration; Applied City Government; A Handbook of Civic Improvements; Municipal Functions, etc.</i>	Chile.
H. H.	HARRY ROYALD HOLLAND HALL, D.LITT., M.B.E., F.S.A. Assistant Keeper of Egyptian and Assyrian Antiquities, British Museum	Archæology: Egypt and Western Asia.

# INITIALS AND HEADINGS OF ARTICLES

1900

H. I. P.	HERBERT INGRAM PRIESTLEY, M.A., PH.D. Associate Professor of Mexican History and Librarian of the Bancroft Library, University of California. Author of <i>José de Gálvez, Visitor-General of New Spain</i> ; etc.	Costa Rica.
H. J. W.	H. J. WILSON, C.B., C.B.E.	Arbitration and Conciliation: <i>United Kingdom.</i>
H. K.	HANS KELSEN, DR. JURIS. Professor of Constitutional Law at the University of Vienna.	Austria, Republic of: <i>Constitution and Administration.</i>
H. L.	H. LUND, M.A.	Denmark ( <i>in part</i> ).
H. L. H. S.	HARRY L. H. SCHÜTZE, M.D. Bacteriologist at the Lister Institute, London.	Bacteriology <i>Medic.</i>
H. L. T.	HENRY LETHBY TIDY, M.A., M.D. (Oxon.), F.R.C.P. (Lond.). Assistant Physician to St. Thomas's Hospital. Physician to the Great Northern Hospital, London.	Encephalitis Lethargica.
H. M. L.	HAROLD MAXWELL LEFROY, M.A., F.Z.S. Professor of Entomology in the Imperial College of Science and Technology, South Kensington. Author of <i>Indian Insect Pests; Indian Insect Life</i> ; etc.	Economic Entomology.
H. N.*	CAPTAIN HOPPMAN NICKERSON, B.A., M.A. (Harvard). Late U.S. Army. Member of New York State Legislature, 1916. In the World War served in G.H.Q. Intelligence Staff, American Expeditionary Force, France.	Artists, Battles in ( <i>in part</i> ).
H. P.	HENRI PIRENNE. Rector of the University of Ghent. Member of the Royal Academy of Belgium and of the Institute of France. Corresponding Member of the Royal Historical Society. Author of <i>Histoire de Belgique</i> ; etc.	Belgium; <i>History (in part)</i> .
H. P. W.	HENRY PARKER WILLES, PH.D. Professor of Banking in Columbia University. Director of Research, Federal Reserve Board. Author of <i>American Banking; The Federal Reserve</i> ; etc.	Banking: <i>United States.</i>
H. R. M.	HUGH ROBERT MILL, D.Sc., LL.D. Gold Medalist of the Royal Geographical Society. Author of <i>The Siege of the South Pole</i> ; etc. See the biographical article: MILL, HUGH ROBERT.	Antarctic Regions.
H. TR.	HANS TIEBE, PH.D. Professor of Art History in the University of Vienna.	Austrian Empire: <i>Art.</i>
H. v. H.	MAJOR-GENERAL HANS VON HAEPFEN. Late General Staff, German Army. Director in the Archives of the Reich. Formerly member of the Historical Section of the Great General Staff. During the World War a General Staff Officer with troops. Representative of the Supreme Command at the Foreign Office, 1918.	Champagne, Battles in ( <i>in part</i> ).
H. W.	HARTLEY WITHERS. Editor of the Financial Supplement of the <i>Saturday Review</i> . Formerly Editor of <i>The Economist</i> . Author of <i>The Meaning of Money, Case for Capitalism</i> ; etc.	Capitalism.
H. WL.	HUMBERT WOLFE, C.B.E.	Demobilization and Resettlement: <i>United Kingdom.</i>
H. W. M.	HENRY WILLIAM MARDON, F.R.G.S. Commander of the Mejidieh. Formerly Lecturer in Geography and Education in the Tewfikieh and Dar el Ulum Colleges, Cairo. Author of <i>A Geography of Egypt and the Anglo-Egyptian Sudan</i> ; etc.	Arabia.
H. W. M.*	HAROLD WOOD MILNER, M.Sc., A.M.I.C.E. Executive Engineer, Public Works Department, Government of India.	Delhi.
L. B. B.	SIR ISAAC BAYLEY BALFOUR, K.B.E., M.D., LL.D.; M.A., F.R.S. Regius Keeper of the Royal Botanic Garden, Edinburgh. Fellow of Magdalen College, Oxford.	Botany: <i>Horticultural Edwardsia.</i>
L. F.	IRVING FISHER, A.B., PH.D. Professor of Political Economy at Yale University. Author of <i>The Nature of Capital and Income, The Purchasing Power of Money; The Rate of Interest</i> ; etc. See the biographical article: FISHER, IRVING.	Dollar Stabilization.
J. A. G.	JAMES ALISON GLOVER, O.B.E., M.A., M.D. (Cantab.), D.P.H. Medical Officer, Ministry of Health. Late Officer in Charge Cerebro-Spinal Fever Laboratory, London District.	Cerebro-Spinal Fever.
J. A. T.*	JOHN ATTON TODD, B.L. Lecturer in Economics, Balliol College, Oxford. Author of <i>The World's Cotton Crops</i> ; etc.	Cotton and Cotton Industry.
J. B. C. K.	JOHN BAKER CANNINGTON KERSHAW, F.I.C., F.I.S.S. Consulting Chemist and Chemical Engineer. Author of <i>The Electric Furnace in Iron and Steel Production; Electro-metallurgy; Electrothermal Methods of Iron and Steel Production.</i>	Electrochemistry and Electrometallurgy.

J. C.	JOVAN CVIJE. Patron's Medalist of the R.G.S. Officer of the Legion of Honour. Professor of Geography in the University of Belgrade. Author of <i>Das Karstphacnosen</i> ; <i>Grundlinien der Geographie und Geologie von Mazedonien und Albanien</i> ; <i>La Peninsule Balkanique</i> .	Balkan Peninsula (in part).
J. C. M.*	COLONEL JOHN COLIN MATHESON, R.E. Deputy Chief Engineer, Southern Command. Formerly Chief Instructor in Fortification, School of Military Engineering, Chatham. Fortification Adviser to the Chilean Government. Member of the Belgian Coast Defences Commission, 1919, and of the Heligoland Commission, 1920.	Coast Defence.
J. C. Mo.	JAMES CECIL MOTTRAM, M.B. (Lond.), D.P.H. (Cantab.). Director of the Research Department, Radium Institute. Late Experimental Officer, Camouflage School, G.H.Q. Author of <i>Controlled Natural Selection</i> .	Camouflage: <i>Natural</i> ; Colours of Animals.
J. E. W.	JAMES E. WEST, LL.B., LL.M. Chief Scout Executive, Boy Scouts of America. Formerly Secretary of President Roosevelt's White House Conference on Care of Dependent Children.	Boy Scouts: <i>United States</i> .
J. H. D.	MAJOR-GENERAL SIR JOHN HUMPHREY DAVIDSON, K.C.M.G., C.B., D.S.O., M.P. Late 60th Rifles. Member for Fareham Division of Hampshire. Served throughout South African War. Instructor in Staff Duties at the Staff College. On the General Staff in France, 1914-8.	Artois, Battles in: (F.) (G.) (H.)
J. Mo.*	RT. REV. MGR. J. MOYES, D.D. Canon of Westminster Cathedral. Formerly Editor of the <i>Dublin Review</i> . Domestic Prelate to H. H. Pope Benedict XV.	Church History: <i>Roman Catholic</i> .
J. M. M.	DR. J. MERRITT MATTHEWS. Head of the Department of Chemistry and Dyeing, Philadelphia Textile School, 1898-1907; Consulting Chemist and Expert in Textile Chemistry and Dyestuffs since 1910. Editor <i>Colour Trade Journal</i> since 1917.	Dyeing: <i>United States</i> .
J. O. P. B.	JOHN OTWAY PERCY BLAND. Author of <i>China; Japan and Korea</i> ; <i>Houseboat Days in China</i> . Joint-author of <i>China under the Empress Dowager</i> . Served in Chinese Maritime Customs, 1883-96. Shanghai Correspondent for <i>The Times</i> , 1897-1910.	China.
J. P.	JACQUES PIRENNE. Associate at the Court of Appeal of Belgium. Professor of History to Prince Leopold of Belgium, Duke of Brabant.	Albert, King of the Belgians; Belgium: <i>History</i> (in part).
J. P.-B.	JAMES GEORGE JOSEPH PENDEREL-BRODHURST. Editor of <i>The Guardian</i> .	Church History: <i>Church of England</i> .
J. R. Co.	JOHN ROGERS COMMONS, A.B., A.M., LL.D. Professor of Economics, University of Wisconsin. Author of <i>Documentary History of American Industrial Society</i> ; <i>History of Labor in the United States</i> ; <i>Principles of Labor Legislation</i> ; etc.	Arbitration and Conciliation: <i>United States</i> .
J. R. J. J.	COLONEL JULIAN ROBERT JOHN JOCELYN, C.B. Late Royal Artillery. Gold Medalist of the Royal Artillery Institution.	Air Bombs (in part).
J. R. R.	RIGHT HON. SIR JAMES KENNEL RODD, G.C.B., G.C.M.G., G.C.V.O. Grand Cross of St. Maurice and St. Lazarus. Commander of the Osmanieh. Grand Cross of Polar Star. Late Ambassador to the Court of Italy. Member of Lord Milner's Mission to Egypt, 1920. Special Envoy to King Mecelek II., 1897. Author of <i>Customs and Lore of Modern Greece</i> ; <i>Poems in Many Lands</i> ; etc.	Egypt: <i>History</i> .
J. SL	JOHN SLATER, B.A. (Lond.), F.R.I.B.A. Formerly President, Architectural Association, and Vice-President, Royal Institute of British Architects, 1900-4. Member of Appeal Tribunal under the London Building Acts. Author of a <i>Short History of The Berners Estate</i> ; Joint-author of <i>Classic and Early Christian Architecture</i> .	Architecture: <i>British</i> .
J. S. Ba.	JAMES STRACHEY BARNES, F.R.G.S. Author of "The Future of the Albanian State" ( <i>R.G.S. Journal</i> , July 1918).	Albania.
K. M.	MAJOR KARL MATERN. Late General Staff, Austro-Hungarian Army. Now of the Kriegsarchiv, Vienna. Author of various monographs on the World War.	Carpathians, Battles of.
K. P.	KARL PRIBRAU, DR. JURIS. Professor in the University of Vienna.	Austrian Empire: <i>Economic Conditions</i> (in part); Austria, Republic of: <i>Economic Conditions</i> (in part)
L. Bw.	LEONARD BAINSTOW, C.B.E., F.R.S., F.R.A.E.S., F.Inst.P. Professor of Aerodynamics at the Imperial College of Science and Technology, South Kensington. Author of <i>Applied Aerodynamics</i>	Aeronautics: <i>Aerodynamics</i> .
L. C. W.	LAWRENCE C. WROTH, A.B. First Assistant Librarian, Enoch Pratt Free Library, Baltimore. Author of <i>Parson Weems: A Biographical and Critical Study</i> , etc.	Baltimore.
L. D.	LETTICE DIGBY, F.N.S. Author of cytological papers in the <i>Annals of Botany</i> ; <i>Archiv für Zellforschung</i> ; etc.	Botany: <i>Cytology</i> .

- L. J. B.** LAWRENCE JOHNSTON BURPEE.  
Secretary, Canadian Section, International Joint Commission. Formerly Librarian of the Ottawa Public Library. Author of *Bibliography of Canadian Fiction; A Little Book of Canadian Essays; Century of Canadian Sonnets*; etc.
- L. J. S.** LEONARD JAMES SPENCER, M.A., Sc.D., F.G.S.  
Assistant Keeper in the Mineral Department, British Museum Natural History. Editor of the *Mineralogical Magazine*. Author of *The World's Minerals*.
- L. Va.** LALLA VANDERVELDE.  
Secretary of the *Institut des Hautes Études*, Brussels University.
- L. v. M.** LUDWIG VON MISES, DR. JURIS.  
Professor of Political Economy in the University of Vienna.
- L. W.\*** LEONARD SIDNEY WOOLF, B.A.  
Sometime Scholar of Trinity College, Cambridge. Author of *Empire and Commerce in Africa; International Government; Coöperation and the Future of Industry*; etc.
- M. B. E.** MIRA BURR EDSON.  
Editor of the *Arts and Crafts Magazine* and *Arts and Crafts Bulletin*. Charter Member of the National Society of Craftsmen and of the Art Alliance.
- M. C. S.** MARIE CARMECHAEI STOKES, D.Sc. (Lond.), Ph.D. (Munich).  
Fellow of University College, London. Sometime Lecturer in Palaeobotany, Universities of Manchester and London. Author of *Catalogue of Cretaceous Plants in the British Museum*, etc.
- M. Fl.** WING COMMANDER MARTIN FLACK, C.B.E., M.A., M.B.  
Director of Medical Research, Royal Air Force. Author of papers on the medical aspect of flying, etc.
- M. K.** DR. M. KRISTIANSEN.
- M. M. W.** MERTON M. WILNER.  
Editorial Writer on the *Buffalo Express*.
- M. O'G.** LIEUTENANT-COLONEL MERVYN O'GORMAN, C.B., D.Sc., M.Inst.C.E.  
Formerly Superintendent of the Royal Aircraft Factory, Farnborough. Consultant to the Director-General of Military Aeronautics. Chairman of the Royal Aeronautical Society, and of the Accidents Investigation Committee of the Air Ministry.
- M. R.\*** MAURICE RECLUS.  
*Conseiller d'État*. Colonial Editor of *Le Temps*.
- M. St. L. S.** MAJOR AND BREVET COLONEL M. St. L. SIMON, C.B.E., R.E.  
Assistant Director, Engineering Services, Canada, 1908-10. Staff Captain, War Office (Fortifications and Works), 1911-5. Anti-Aircraft Defence Commander, London, 1916-8. Anti-Aircraft Defence, Independent Force, R.A.F., 1918. Anti-Aircraft Defence, Leeds, 1919. Commander of Northern Air Defences, 1919. General Staff, War Office, 1920-1.
- N. M. B.** NICHOLAS MURRAY BUTLER, Ph.D., LL.D. (Cantab.), JUR.D., Hon. D.Litt. (Oxon.).  
See the biographical article: BUTLER, N. M.
- N. W.** NORMAN WILKINSON, O.B.E., R.I.  
Marine Painter and Encher. Originator of Dazzle Painting (Naval Camouflage) as used by the Allied Powers in the World War. Author of *The Dardanelles*.
- O. Kr.** OTTO KRIEGK, Ph.D. (Göttingen).  
Member of the Staff of the *Weser Zeitung*, Berlin Office.
- O. L.-L.** OLIVER STILLINGFLEET LOCKER-LAMPSON, C.M.G., D.S.O., M.P., B.A.  
Parliamentary Secretary (Private) to Mr. Austen Chamberlain as Chancellor of the Exchequer and as Leader of The House of Commons. Author of *The Great Preference Debate*.
- O. S.** OSKAR STARK.  
Member of the Berlin Staff of the *Frankfurter Zeitung*.
- O. v. K.** BARON OTTO VON KLIMBERG, DR. JURIS.
- P. B.** PAUL BOURSON.  
Member of the Commissariat General of the French Republic at Strasbourg.
- P. Vl.** SIR PAUL VINOGRADOFF, M.A., D.C.L., LL.D., DR. HIST., DR. JURIS.  
Corpus Professor of Jurisprudence, Oxford. Author of *Villainage in England; The Growth of the Manor; Outlines of Historical Jurisprudence*; etc. See the biographical article: VINOGRADOFF, SIR PAUL.
- Canada: *English Canadian Literature.*
- Crystallography.
- Belgium: *Literature.*
- Austrian Empire: *Finance and Banking; Austria, Republic of: Finance and Banking.*
- Coöperation.
- Arts and Crafts: *United States.*
- Botany: *Anatomy and Palaeobotany.*
- Aerotherapeutics.
- Denmark (*in part*).
- Buffalo.
- Aeronautics: *Introduction.*
- Algeria.
- Air Defence.
- Columbia University; Education: *United States (in part).*
- Camouflage: *Naval.*
- Bremen.
- Chamberlain, J. Austen.
- Bavaria: *Political History.*
- Bosnia and Herzegovina.
- Alsace-Lorraine.
- Benckendorff Count; Demkin, Anton.



- RI.** **RIGHT HON. LORD RIDDELL.**  
Vice-Chairman of the Newspaper Proprietors' Association. Chairman of the Weekly Newspaper and Periodical Proprietors' Association. Represented the British Press at the Peace Conference, 1919-21. See the biographical article: **RIDDELL, LORD.** } **Censorship (in part).**
- R. A. C.** **RALPH ADAMS CRAM, Litt.D. (Princeton), LL.D. (Yale), F.R.G.S.**  
Fellow of the American Institute of Architects and of the North British Academy of Arts. Hon. Corresponding Member of the Royal Institute of British Architects. Associate of the National Academy. Member of the American Institute of Arts and Letters. Supervising Architect, Princeton University. Lecturer on the Philosophy of Architecture, Massachusetts Institute of Technology. Member of the firm of Cram, Goodhue & Ferguson. Author of *Church Building; The Ruined Abbeys of Great Britain*; etc. See the biographical article: **CRAM, RALPH ADAMS.** } **Architecture: United States.**
- R. B.-P.** **LIEUTENANT-GENERAL SIR ROBERT BADEN-POWELL, BART., K.C.B., K.C.V.O. LL.D.**  
Chief Scout. } **Boy Scouts: United Kingdom.**
- R. DeC. W.** **ROBERT DeCOURCY WARD, A.M.**  
Professor of Climatology, Harvard University. Author of *Climate Considered Especially in Relation to Man.* } **Climate and Climatology.**
- R. F. T.** **RICHARD F. TAYLOR, M.B.E., F.S.S.**  
Statistician to the Ministry of Mines. } **Coal: United Kingdom.**
- R. H. G.** **RALPH HENRY GABRIEL, Ph.D.**  
Assistant Professor of History in Yale University. Author of *The Evolution of Long Island*, etc. } **Connecticut.**
- R. K.** **LIEUTENANT-COLONEL RUDOLF KISZLING.**  
Late General Staff, Austro-Hungarian Army. Now of the Kriegsgeschichtsbüro, Vienna. } **Eastern European Front Campaigns (in part).**
- R. K. B.-W.** **BRIGADIER-GENERAL RALPH KIRBY BAGNALL-WILD, C.M.G., C.B.E., R.A.F. M.I.MECH.E.**  
Director of Aircraft Inspection. Fellow and Past Chairman of the Royal Aeronautical Society. Commission, Royal Engineers, 1893. Inspector of Aircraft, 1913. } **Aeronautics: Materials and Methods of Manufacture.**
- R. K. H.** **LIEUTENANT-COLONEL ROBERT KNOX HEZLET, C.B.E., D.S.O.**  
Royal Field Artillery. Superintendent of External Ballistics, Ordnance Committee. Author of *Nomography; Interior Ballistics*; etc. } **Ballistics (in part).**
- R. M. H.** **SQUADRON LEADER R. M. HILL, R.A.F., M.C., A.F.C.**  
Associate Fellow of the Royal Aeronautical Society. Formerly in charge of the Experimental Flying Department, Royal Aircraft Establishment. Author of paper to the Royal Aeronautical Society: *A Comparison of the Flying Qualities of Single- and Twin-Engined Aeroplanes*; Aeronautical Research Committee Reports and Memoranda No. 678; *The Influence of Military and Civil Requirements on the Flying Qualities of Aeroplanes.* } **Aeronautics: Performance of Aeroplanes.**
- R. M. WL.** **R. McNAIR WILSON, M.B., Ch.B.**  
Fellow of the Royal Society of Medicine. Editor, Oxford Medical Publications. Late Research Worker in Cardiology, Medical Research Committee. Consultant to the Ministry of Pensions in Trench Fever. } **Bilharziosis; Burns and Scalds; Cancer.**
- R. McK. W.** **RONALD McKENNON WOOD, B.A. (Cantab.), A.M.I.C.E., F.R.A.E.S.**  
Head of Aerodynamics Department, Air Ministry. } **Aeronautics: Development of Acroplane Design.**
- R. N. R. B.** **ROBERT N. RUDMOSE BROWN, D.Sc.**  
Member of the Scottish National Antarctic Expedition, 1902-4, and of the Scottish Arctic Expeditions, 1909, 1912 and 1914. Lecturer in Geography, University of Sheffield. Author of *Spitzbergen*, etc. Joint-author of *The Voyage of the Scotia.* } **Åland Islands; Arctic Regions.**
- R. P. D.** **R. PALME DUTT.**  
Late Scholar of Balliol College, Oxford. Author of *The Two Internationals*. Editor of *The Labour International Handbook.* } **Communism.**
- R. SI.** **ROBERT SIEGER, Ph.D.**  
Professor of Geography, University of Graz; Member of the Academy of Science, Vienna. } **Austria, Republic of: Introduction; Economic Conditions.**
- R. Str.** **RICHARD STRIEGL, Dr. JURIS.**  
Secretary of the Industrial District Commission. } **Austrian Empire: Economic Conditions (in part).**
- R. Th.** **RALPH THICKNESSE.**  
Barrister-at-Law. Author of *Digest of Law; Husband and Wife*; etc. } **Children, Law Relating to: United Kingdom; Divorce: United Kingdom.**
- R. T. T.** **SIR REGINALD THOMAS TOWER, K.C.M.G., C.V.O.**  
Administrator of Danzig and High Commissioner of the League of Nations, 1919-20. } **Danzig.**
- R. van O.** **CAPITAINE-COMMANDANT R. VAN OVERSTRAËTEN.**  
Aide-de-Camp to H. M. The King of the Belgians. Graduate of the Staff College. Order of Leopold. D.S.O. Legion of Honour. } **Antwerp: Siege of 1914; Army: Belgian.**

S. B. W.	S. B. WILLIAMS. Assistant Managing Editor of <i>Electrical World</i> .	{ Electricity Supply; United States.
S. G. P.	SYDNEY GROSS PAINE, D.Sc., F.I.C. Assistant Professor of Bacteriology, Imperial College of Science and Technology, London.	{ Bacteriology; General and Agricultural.
St. J. E.	St. JOHN GREHR ERVINE. Dramatic Critic of <i>The Observer</i> . Author of <i>The Magnanimous Lover; Mixed Marriage; Jane Clegg</i> ; and other plays.	{ Drama.
S. P. S.	STANLEY PARKER SMITH, D.Sc., M.I.E.E., A.M.I.C.E. Joint-author of <i>Papers on the Design of Alternating Current Machinery</i> .	{ Electrical Engineering (in part).
S. R. W.	REV. STACEY R. WARBURTON, B.A. Editor of <i>Year Book of the Churches</i> . Secretary of Literature of the General Board of Promotion of the Northern Baptist Convention, U.S.A.	{ Church History: United States.
S. V.	SWALE VINCENT, LL.D., D.Sc., M.D., F.R.S.E., F.R.S.C. Professor of Physiology in the University of London. Author of <i>Internal Secretion and the Ductless Glands</i> .	{ Ductless Glands.
T. C. McC.	THOMAS CHALMERS MCCORVEY, M.A., LL.D. Professor of History and Political Science in the University of Alabama. Author of <i>The Government of the People of the State of Alabama</i> . Contributor to <i>The Library of Southern Literature</i> and <i>The South in the Building of the Nation</i> , etc.	{ Alabama.
T. G. M.	THOMAS GARRIGUE MABARYK. President of the Czechoslovak Republic.	{ Czechoslovakia.
V. B.-J.	CAPTAIN VIVIAN BULKELEY-JOHNSON. Entered Rifle Brigade, 1913. Served in France, 1914-5. G.H.Q., 1916. Aide-de-Camp to Governor-General of Canada, 1916-8. Officer of the War Cabinet, 1928-9. Air Ministry, 1919-21.	{ Aeronautics: Control of Air Traffic.
V. H. B.	VERNON HERBERT BLACKMAN, Sc.D., F.R.S. Professor of Plant Physiology and Pathology in the Imperial College of Science and Technology.	{ Botany: General Physiology.
V. L. E. C.	GENERAL VICTOR LOUIS ÉMILIEN CORDONNIER. See the biographical article: CORDONNIER, V. L. E.	{ Argonne, Battles of the; Army: French.
W. A. P.	WALTER ALBION PHILLIPS, M.A. (Oxford and Dublin). Lecty Professor of Modern History in the University of Dublin. Member of the Royal Irish Academy. Author of <i>Modern Europe; The Confederation of Europe</i> ; etc.	{ Diplomacy.
W. B. A.	W. BROUGHTON ALCOCK. Director Central Laboratory, Ministry of Pensions.	{ Dysentery.
W. F. S.	WILLIAM F. SPALDING, CERT.A.I.B., F.R.ECON.S. Examiner in Banking, Currency and Foreign Exchange to various public bodies. Author of <i>Foreign Exchange and Foreign Bills in Theory and in Practice; Eastern Exchange; Currency and Finance</i> ; etc. Sometime Editor of the <i>Statist</i> British Banking Supplement and International Banking Supplement.	{ Banking: British.
W. G. C.	WILLIAM GEORGE CONSTABLE, M.A. Fellow of St. John's College, Cambridge. Barrister-at-Law. Lecturer at the Wallace Collection.	{ Beerbohm, Max; Bernard, P. A.
W. G. Ma.	MAJOR-GENERAL SIR WILLIAM GRANT MACPHERSON, K.G.M.G., C.B., LL.D. Editor-in-Chief of the <i>Medical History of the Great War</i> . Formerly Deputy Director-General, Army Medical Service. Author of <i>Handbooks of the Medical Services of Foreign Armies</i> , etc.	{ Army Medical Service: British.
W. G. S. A.	WILLIAM GEORGE STEWART ADAMS, M.A. Gladstone Professor of Political Theory and Institutions in the University of Oxford.	{ Education: United Kingdom.
W. H. T.	COLONEL W. H. TSCHAPPAT (U.S. Army). Author of <i>Ordnance Treatise</i> , U.S.A.	{ Ammunition (in part); Ballistics (in part).
W. J. C.*	W. J. CHILDS. Late of the Intelligence Department of the Admiralty (Geographical Section)	{ Armenia; Azerbaijân; Cilicia.
W. K. McC.	WILLIAM KIDSTON McCLURE, M.A. (Oxon). Late Correspondent of <i>The Times</i> in Rome. Correspondent of <i>The Times</i> on the Italian Front, 1915-7. Author of <i>Italy's Part in the War; Italy in North Africa</i> ; Chapters on Italy in <i>The Times History of the War</i> ; etc.	{ Asiago, Battle of; Cadorna, General; Caneva, Carlo; Caporetto, Battle of.
W. L. C.	MAJOR WALLACE L. CLAY. Ordnance Department of the U.S. Army.	{ Ammunition (in part).
W. L. G.*	WILLIAM L. GRIFFITH. Permanent Secretary, Office of the High Commissioner for Canada, London. Author of <i>The Dominion of Canada</i> ; article on "Canada," <i>Oxford Survey of the British Empire</i> .	{ Alberta; British Columbia; Canada.

W. L. P.	WILLIAM LYON PHELPS, M.A., PH.D., LITT.D. Lampson Professor of English Literature at Yale University. Author of <i>Essays on Modern Novelists; Essays on Russian Novelists; Essays on Modern Dramatists; The Twentieth Century Theatre; The Advance of English Poetry; etc.</i>	American Literature.
W. P.	WOODFORD PATTERSON, B.A. Secretary of Cornell University.	Cornell University.
W. P. C.	WESTON P. CHAMBERLAIN. Colonel, Army Medical Corps, U.S. Army.	Army Medical Service: United States.
W. R. L.	WALTER REXTON INGALLS. Consulting Mining and Metallurgical Engineer, New York. Author of <i>Metallurgy of Zinc and Cadmium.</i>	Copper.
W. R. Ma.	WILLIAM R. MANNING, PH.D. Economist, Latin-American Division, U.S. Department of State. Author of <i>Nootka Sound Controversy</i> (Justin Winsor Prize Essay of American Historical Association, 1904); <i>Early Diplomatic Relations Between the United States and Mexico</i> (Albert Shaw Lectures, Johns Hopkins University, 1913); etc.	Cuba.
W. St.	WILLIAM STOCKING, M.A. (Yale). Newspaper Editor, 1865-1900. Historian and Statistician, Detroit Board of Commerce, 1903-21. Author of <i>Under the Oaks; History of the Republican Party; etc.</i>	Detroit.
W. S. Ro.	WILLIAM SPENCE ROBERTSON, PH.D. Professor of History in the University of Illinois. Author of <i>Francisco de Miranda and the Revolutionising of Spanish America; Rise of the Spanish American Republics; etc.</i>	Bolivia; Colombia; Ecuador.
W. v. B.	WILHELM VON BLUMF DR. JURIS. Professor of Law in the University of Tübingen. Author of <i>Familienrecht des Bürgerlichen Gesetzbuchs; Erbrecht des Bürgerlichen Gesetzbuchs.</i> Coöperated in the drafting of the Constitution of Württemberg, 1919.	Baden, Bavaria (in part).
W. Wo.	LIEUTENANT-CORONEL WILLIAM WOOD, D.C.L., F.R.S. (Canada). Reserve of Officers, Canadian Army. Coördinating Officer of the Canadian Special Mission at the Naval and Military Fronts, 1917. Formerly President of English Section of Royal Society of Canada and of Historic Landmarks Association. Author of <i>The Fight for Canada; The Logs of the Conquest of Canada; Folk Songs of New France; etc.</i>	Canada: Literature, French Canadian.
X.	Initial used for anonymous contributors.	
Y. C.	YVES CHATAIGNEAU. American Distinguished Service Cross. Knight of the Legion of Honour. Lecturer in the University of Belgrade. Author of " <i>L'Émigration Vendéenne</i> ," <i>Annales de Géographie</i> , 1917, " <i>La Yougo-Slavie</i> ," <i>Annales de Géographie</i> , 1921	Balkan Peninsula (in part)
Y. D.	GENERAL YOURI DANILOV.	Army: Russian (in part).

# ENCYCLOPÆDIA BRITANNICA

## VOLUME XXX

### THE FIRST OF THE NEW VOLUMES

**ABBE, CLEVELAND** (1838–1916), American meteorologist, was born in New York Dec. 3 1838. He studied astronomy under Brünnow and B. A. Gould, and spent a year at the Pulkovo Observatory, 1865–6, under Struve. He was assistant at the U.S. Naval Observatory, 1867–8, and Director of the Cincinnati Observatory, 1863–73. His success there in forecasting the weather from meteorological observations telegraphed from various points led to his being called to the U.S. Signal Service in 1871. Thereafter with Government aid he was enabled to extend the field of his forecasts and became the "Father of the Weather Bureau." The bureau was formally established in 1891 under the Department of Agriculture, and Abbe remained its head until his death Oct. 28 1916. To his initiative is largely due the introduction of the system of standardized time.

He was the author of *Report on Standard Time* (1879); *Report on the Solar Eclipse of July 1879* (1881); *An Account of Progress in Meteorology and Allied Subjects in the Years 1870–81* (1883); *Treatise on Meteorological Apparatus and Methods* (1888); *Preliminary Studies in Storm and Weather Prediction* (1889); *Recent Progress in Dynamic Meteorology* (1890); *The Mechanics of the Earth's Atmosphere* (3 vols. of translations, 1891–1910); *The Physical Basis of Long-Range Forecasting* (1902); *The Progress of Science as Illustrated by the Development of Meteorology* (1908); *Notes on Balloons and on Waterspouts from the Voyage of La Pérouse* (1914) and *The Introduction of Meteorology into Courses of Instruction in Mathematics and Physics* (1915).

**ABBEY, EDWIN AUSTIN** (1852–1911), American painter (see 1.11), died in London, Aug. 1 1911. The last years of his life were devoted to mural paintings for the Capitol at Harrisburg, Pa., his native state. He completed "The Apotheosis of Pennsylvania," which stands behind the Speaker's chair in the House of Representatives, also "The 24 Hours" for the ceiling of the dome; but for the Senate chamber he finished only one painting — "Von Steuben Training the American Soldiers at Valley Forge." In 1910 there was completed under his supervision the decoration of the Peers' corridor of the Houses of Parliament. He left bequests of his works to the Metropolitan Museum of Art in New York, to the Boston Museum of Fine Arts and to the National Gallery in London. In 1912, the *Old Masters' Exhibition* of the Royal Academy, held at Burlington House, London, included over 300 works of Abbe's loaned for this special occasion as a memorial to him.

**ABBOTT, LYMAN** (1835– ), American divine and author (see 1.26), continued after 1910 as editor of *The Outlook*, and in a less degree as a public speaker, to take an active part in the discussion of important public questions. After the outbreak of the World War he supported the cause of the Allies, and on the sinking of the "Lusitania" in 1915 urged that America break off diplomatic relations with Germany. He was the author of

*The Spirit of Democracy* (1910); *America in the Making* (1911, being the Yale lectures on the responsibilities of citizenship); *The Four Anchors* (1911); *Letters to an Unknown Friend* (1913); *Reminiscences* (1915, containing in the preface an admirable summary of his liberal views) and *The Twentieth Century Crusade* (1918).

**'ABDUL HAMID II.** (1842–1918), ex-Sultan of Turkey (see 1.35), died Feb. 10 1918. On his deposition in April 1909 he was sent to Salonika as a state prisoner, but when that town capitulated to the Greeks during the Balkan War (1912) he was brought back to Constantinople. In 1915 it was judged prudent to exile him from Turkey in Europe and he was removed to Smyrna.

**ABERCORN, JAMES HAMILTON, 2ND DUKE OF** (1838–1913), British politician (see 1.43), who served as High Constable of Ireland at the coronation of King George V. (1911), died in London Jan. 3 1913. He was succeeded as 3rd duke by his eldest son, James Albert Edward Hamilton, born Nov. 30 1869.

**ABERCROMBIE, LASCELLES** (1831– ), English poet, was born at Ashton-upon-Mersey, Ches., Jan. 9 1831, and educated at Malvern and Victoria University, Manchester, where he studied science. His first work, *Interludes and Poems*, appeared in 1908, and his other works include: *Mary and the Bramble* (1910); *The Sale of St. Thomas* (1911); *Emblems of Love* (1912); *Deborah* (1912); *Speculative Dialogues* (1913) and *The Epic* (1914), besides a critical study of Thomas Hardy (1912). He was in 1919 appointed lecturer in Poetry at the university of Liverpool.

**ABERDEEN AND TEMAIR, JOHN CAMPELL GORDON, 1ST MARQUESS OF** (1847– ), British politician (see 1.47), retained his office as Lord-Lieutenant of Ireland until 1915. On his retirement he was created Marquess of Aberdeen and Temair, the latter title being a form of the place-name Tara, chosen for its connexion with the history of Ireland. His wife, Isabel Maria (b. 1857)—daughter of Dudley Marjoribanks, 1st Baron Tweedmouth—whom he married in 1877, took a prominent part in charitable work during her residence in Ireland, becoming president of the Irish Industries Association and other societies. She did excellent work in increasing the number of nurses and establishing committees for the improvement of sanitary conditions and combating the spread of tuberculosis in Ireland. She published in 1908 *Ireland's Crusade against Tuberculosis*.

**ABINGDON, WILLIAM LEPER (PLUGRIM)** (1859–1918), English actor, was born May 2 1859 at Towcester, Northants. He began life as a bank clerk, but soon went on the stage, first appearing at Belfast in 1881. His chief successes were in melodrama, with Wilson Barrett's travelling companies and later at the Adelphi theatre, London, where he played in *The Harbour Lights* (1889) and many similar pieces. Between 1903 and 1911

he appeared often in America. In 1905 he played Monks in *Oliver Twist* at His Majesty's theatre, London. He died in New York May 20 1918.

**ABNEY, SIR WILLIAM DE WIVELESLE** (1843-1920), English chemist, was born at Derby July 24 1843 and educated at Rossall school, obtaining a commission in the R.E. 1861. In 1876 he became C.B., D.Sc., D.C.L. and F.R.S. and from 1893 to 1897 he was successively president of the Royal Astronomical Society and of the Physical Society. In 1899 he became assistant secretary to the Board of Education; in 1903 he was appointed advisor to the science department of the Board, and the same year became a member of the Advisory council for education to the War Office. In 1900 he was knighted and in 1904 became chairman of the Society of Arts. His contribution to science was mainly in the furtherance of photographic, chemistry and especially of colour photography and colour printing (see 16.661; 21.489, 498, 531, 532; 25.631; 6.729). His publications on these subjects include *Instruction in Photography* (1870); *Colour Vision, Colour Measurement and Mixture* (1893); and *Trichromatic Theory of Colour* (1914). He also wrote *Thebes and its Five Great Temples* (1876), and, with C. D. Cunningham, *The Pioneers of the Alps* (1888). He died at Folkestone Dec. 3 1920.

**ABRUZZI, DUKE OF THE (LUIGI AMEDEO)** (1873- ), Italian vice-admiral and explorer, son of Amedeo, late Duke of Aosta and sometime King of Spain, was born at Madrid Jan. 29 1873. He entered the navy as a cadet and followed a regular naval career in which he achieved great distinction; but he also became well known as an eminent traveller and mountaineer. He was the first to ascend Mt. St. Elias in Alaska (1897), and in 1899 he organized an expedition with the object of reaching the North Pole; although he himself was disabled by frostbite early in 1900 and forced to remain on his ship, the "Stella Polare," Comm. Cagni pushed on with a part of the expedition and reached the lat. of 86° 34', at that time the record of northern exploration. In 1906 he was the first to ascend Mt. Ruwenzori in East Africa, reaching the twin summits (16,800 ft.), which he named Margherita and Alexandra, and also the other chief peaks of the range; he made the first detailed map of the Ruwenzori and collected much scientific information about it. In 1909 he explored the Central Karakoram in the Himalayas and by ascending peak K2 achieved the record for height; among other scientific work the expedition completed the map of the great Baltoro glacier. During the Libyan War he commanded a naval squadron in the Adriatic and had various successful engagements with Turkish warships. During the World War he was commander-in-chief of the Italian naval forces, and showed very high qualities of seamanship, strategy and organization in the extremely difficult operations in the Adriatic. He had British and French warships under his orders. He relinquished his command in 1917 owing to disagreements with Adml. Thaon di Revel, chief of the Naval Staff, and retired from the service. Afterwards he undertook an important colonization and agricultural development scheme in Italian Somaliland. He was made a Knight of the Order of the Annunziata.

**ABYSSINIA** (see 1.82).—Since 1910 boundary commissions have delimited in part the Sudan-Abyssinia and the Italian-Abyssinian frontier. No change was made in the international status of the country between 1910 and 1921. The conquests of Menelek had been retained and the independence of the empire maintained. The Spanish protectorates excepted, Abyssinia was the only country of Africa neutral throughout the World War.

*Recent History.*—From 1899, a year which marked the end of an era of conquest and civil war, the Emperor Menelek (see 18.128) had maintained internal peace and had cautiously encouraged commercial relations with Europeans. But in 1910 Menelek was stricken by a malady which incapacitated him from rule, although until his death, in Dec. 1913, and for years afterwards (e.g. in 1919), his name was invoked by the people as that of the highest authority in the country. A regency was formed in 1910, consisting of Lij Yasu—Menelek's grandson,

whom he had nominated his heir in 1908—and Ras Tesemma, Lij Yasu being then only fourteen. Menelek's wife, the Empress Taitu, a princess of Tigré, opposed the regency, called to her aid the Tigrinian chiefs, and usurped authority. She refused to see the representatives of foreign powers and stopped the building of the railway from Jibuti (see 1.95) to the capital, Addis Abbaba. After maintaining her position about a year Taitu was overthrown by a palace revolution. She took no further part in the government and died Feb. 11 1918.

Not long after the regency was established Ras Tesemma, a capable man of moderating influence, died, April 1911. Lij Yasu then attempted to reign uncontrolled. He was strongly opposed; but with the help of his father Ras Michael, chief of the Wollo Galla, Yasu made good his authority and on Menelek's death was acknowledged *negus negusti* (king of kings, emperor).

At that time, the beginning of 1914, the condition of the country was not without promise. The building of the railway from Jibuti had been resumed; in 1912 it had reached the Hawash river, and was then (1914) being carried up the steep escarpment to the Abyssinian plateau. Even in its incomplete state it carried in 1913 merchandise valued at over £1,600,000. A considerable trade between the Galla provinces (western Abyssinia) and the Sudan had also developed. Both Abyssinians and Gallas showed a distinct appreciation of foreign products; it needed only good government and the provision of better means of communication to have brought about a great development of the very rich natural resources of the country. Lij Yasu, however, was a youth of depraved morals, his administration was both weak and tyrannical, and the result was in the south anarchy,<sup>1</sup> and in the north the alienation of the Tigrinians, always jealous of Shoa (Menelek's hereditary kingdom). The maintenance of a large standing army was another cause of poverty and discontent. Out of a total population, according to trustworthy estimates, of from 10,000,000 to 12,000,000, about 500,000 were in the army. (Detailed figures for 1916 gave a total of 571,000 as the strength of the Abyssinian forces.) In the Galla, Somali and Shankalla (i.e. negro) provinces these men lived largely by plunder.

Such was the situation when the World War broke out. Lij Yasu had already come very much under German and Turkish influence, the chief agent in the propaganda of the Central Powers having been Herr K. Schwemmer, consul for Austria-Hungary. (Schwemmer, owing to Italian pressure, was recalled to Vienna and left Abyssinia in Oct. 1914.) Yasu had already given offence to the Abyssinians, whose attachment to their own form of Christianity is strong, by his neglect of the observances of the national church, and in June 1914 had caused his father, Ras Michael, to be crowned *negus* (king) of Wollo, the only province of Abyssinia proper inhabited by Moslems (Galla intruders). Michael remained nominally a Christian; Yasu, at first secretly and later openly, embraced Islam, and, inspired by Turco-German policy, set himself to unite all the Moslems of the empire. He married the daughters of several Danakil and Galla chiefs, and betrothed himself to the daughter of Aba Jiffar, King of Jimma, the most powerful Moslem prince in the empire. He also made political alliances with Moslems outside the Abyssinian dominions, among others with the "Mad" Mullah of Somaliland, then at war with the British. His policy was summed up as (1) Moslem as opposed to Christianity; (2) Galla as opposed to Abyssinian; (3) Turco-German as opposed to the Entente.

In April 1916 Yasu officially placed Abyssinia in religious dependence on the Sultan of Turkey as Caliph and sent to the Turkish consul-general at Harrar an Abyssinian flag bearing the crescent and a confession of faith in Islam. About this time he informed his Moslem confederates—who had been told that Germany and Austria had embraced Islam and had imposed that faith upon France—that he would lead them against the Allies as soon as a great German victory should be announced.

<sup>1</sup>One result was raiding into the Sudan and adjacent territories by Abyssinians. These raids the central Government did not see could not prevent.

His anti-Christian, anti-Abyssinian attitude led to Yasu's downfall. The Allied representatives at Addis Abbaba, in particular the Hon. W. G. Thesiger, then the British minister, did much to counteract Turco-German propaganda and, except Ras Michael, all the Abyssinian chiefs were opposed to the Emperor's proceedings. They had the support of the people, the Shoans as well as the men of Tigré and Gondar, and they determined to end an intolerable situation. On Sept. 27 1916—the Feast of the Cross—by a public proclamation of the Abuna (the head of the church) Lij Yasu was declared dethroned, on the specific ground of his apostasy. His aunt, the Princess Zauditu (Judith), who had been a prisoner in the palace since Menelek's illness in 1910, was proclaimed empress. Dejas (general) Taffari Makonnen, a cousin of Zauditu, was appointed heir to the throne and regent with the title of Ras (prince). The new régime was at once accepted, practically unopposed, by the chiefs and people of Shoa and by the imperial army (a force of 50,000 kept in the neighbourhood of the capital).

Lij Yasu was then at Harrar, a Moslem centre, arming the Somalis. On receipt of the news of his deposition he showed the weakness of his character by publicly renouncing Islam, a step which gained him no credit either with the Abyssinians or the Somalis. The garrison of Harrar (Abyssinians), sent by Yasu to oppose the Shoa troops which the new rulers had dispatched against him, joined his enemies. On Oct. 8 Yasu fled secretly from Harrar, making for the Danakil country. On the 9th Harrar was occupied by the Shoans, who killed some 400 unresisting Somalis before the slaughter was stopped through the intervention of the British consul.

Ras Michael was made of sterner stuff than his son; moreover, the Wollo Galla remained faithful to him and he was able to put some 80,000 men in the field. Wollo lies on the eastern edge of the Abyssinian plateau, with Gondar and Tigré N. and N.W. and Shoa to the S. Leaving 20,000 to 30,000 men to guard his northern frontier, Ras Michael marched S., hoping to capture Addis Abbaba by a rapid blow. Meantime the new Government had prepared to advance N., fixing on Shano, 40 m. N.E. of the capital, as the place of concentration. Michael, who was first in the field, had an engagement with the advanced force of the Shoans under Ras Lul Seged Oct. 17, before whom he gave way. But on the 19th Michael surrounded and destroyed Lul Seged's force in a furious battle in which over 12,000 men perished. Lul Seged himself was slain, but his resolute defence had delayed Michael's advance; it gave time to the Shoans to complete their concentration. By Oct. 21 they had 60,000 men at Shano, and a great superiority in artillery over Michael. On the 22nd Shoa cavalry under Ras Kassa' seized a position in the rear of Michael's army; the same day his force on the northern frontier was attacked and defeated by the Ras of Gondar (Waldo Giorgis). Cut off from his base, almost enveloped and with supplies running short, Michael's only alternative to being starved into surrender was to attack. The King chose the latter course and gave battle at Shano on Oct. 27. The fighting was desperate and the slaughter great. The Shoans were at first hard pressed but the timely arrival of Ras Kassa's cavalry decided the issue. The Wollo army was utterly routed, Michael was taken prisoner and all his artillery captured. This ended the campaign, in which in three weeks over 60,000 lives are said to have been lost, the casualties of the Shoans alone exceeding 20,000. The Fitaurai Hapti Giorgis, Minister of War, who had commanded in chief the Shoa forces, made no attempt to occupy Wollo or to pursue Lij Yasu and thus effectively pacify the country. He returned to Addis Abbaba where the Empress Zauditu reviewed the victorious troops, the ceremony ending with the parade of Ras Michael, a fine-looking, dignified man of about 65, chained to the chief who had captured him.

Profiting by the inactivity of the Government, Lij Yasu gathered together the remnants of his father's army. He managed to keep his footing in the Wollo country for the greater part of 1917 and finally took refuge in Magdala. Closely besieged, Magdala surrendered in Dec. 1917. Lij Yasu escaped, and

<sup>1</sup> Abyssinian envoy to London for the coronation of George V.

thereafter appears to have led a wandering life among the Danakil and Somali. In Oct. 1918 he was appealing to the Turks in Arabia for help, and making attempts to raid the Jibuti railway. At the close of 1920 Yasu appeared in Tigré, apparently hoping to gain over that province, but in Jan. 1921 he was captured by Government forces.

The Government of the Empress Zauditu and Ras Taffari was pro-Ally and in the summer of 1919 missions were sent to London, Paris, Rome, Brussels and Washington to congratulate the Allies on their victory. These missions received good advice as to the necessity of an amelioration of social conditions in Abyssinia, the suppression of slavery—Menelek's conquests had given a great impetus to the slave trade—and the development of commerce and agriculture.

*Economic Conditions and Trade*.—Two great hindrances to the economic development of the country have been stated—internal disturbances and lack of adequate means of communication. After the close of the World War, and with the railway from the Gulf of Aden to Addis Abbaba completed, an improvement was anticipated. A British company, the Abyssinian Corporation, was formed in Dec. 1918, with the approval of the Foreign Office, but owing to restriction of shipping, the fluctuations of exchange and the fall in the price of coffee its first two years' operations were unsatisfactory. Nevertheless the total trade of Abyssinia increased. Valued at about £1,000,000 in 1905, it had more than doubled by 1910; and in 1920, in the absence of any official statistics, was roughly estimated at between £3,500,000 and £4,000,000. Hides and skins, coffee and beeswax are the chief exports. The chief imports are cotton goods and Maria Theresa dollars (minted at Trieste and an exact reproduction of the 1780 issue). The external trade of northern Abyssinia is with Massawa via Asmara; that of Shoa and Harrar with Jibuti and, to a small extent, with Zeila and Berbera (British Somaliland). These are all ancient routes to the sea-coast; to the old trade routes to the Sudan by the Blue Nile has been added that by the Baro-Sobat rivers. Gambela, on the Baro and 60 m. within the Abyssinian frontier, was leased to the Sudan Government in 1907, and in the Sobat flood season (June-Nov.) a steamer service is maintained with Khartoum. Although the road from the Baro river to Gore, on the highlands, was and remained very bad, Gambela became an important transport centre. The value of its trade, £43,000 in 1910, was £103,000 in 1913 and was estimated at about £200,000 in 1919. Much of the trade in the country is in the hands of Greeks, Syrians and Arabs. The agricultural and mineral wealth of the country remain as yet—if the cultivation of coffee be excepted—scarcely tapped, and its water-power unutilized.

See L. de Castro, *Nella Terra del Negus*, 2 vols. (1915); Capt. Stigand, *To Abyssinia through an Unknown Land* (1910); G. Montandon, *Au Pays Ghimirra* (1913); Major C. W. Gwynn, "A Journey in S. Abyssinia" (with map), *Geog. Jnl.*, Aug. 1911; Major F. L. Attili, "Through S. W. Abyssinia to the Nile," *ibid.*, Nov. 1920; C. H. Armbruster, *Initia Amharica, Part III. Amharic-English Vocabulary*, Vol. I. (1920).

**ACHENBACH, ANDREAS** (1815-1910), German painter (see 1.242), died in 1910.

**AGHURCH, JANET** [Mrs. C. CHARRINGTON] (1864-1916), English actress, was born in Manchester Jan. 17 1864. She married Charles Charrington June 1880. She first appeared at the Olympic theatre, London, Jan. 8 1883, with Geneviève Ward in the farce of *Betsy Baker*. Two years later she joined Frank Benson's company and played Shakespearean heroines; but her chief success was gained as Nora Helmer in Ibsen's *A Doll's House*, when that play was first produced in England in 1889. She appeared later in other Ibsen plays and in those of Bernard Shaw. She died at Ventnor Sept. 11 1916.

**ADAM, JULIETTE** (1836- ), French writer (see 1.172), whose volumes of reminiscences of distinguished contemporaries numbered seven by 1910, subsequently published *Impressions françaises en Russie* (1912) and *Christienne* (1913), as well as various writings in pursuit of her lifelong policy of *revanche*, *L'heure vengeresse des crimes bismarckiens* (1915), *Gaillaume II. 1890-9* (1917), and a volume of war sketches, *La vie des dames* (1910).

**ADAM, PAUL** (1867-1920), French novelist (see 1.72), published in his later years various novels, including *Le Trust* (1910) and *Séplianis* (1913). He was active in propaganda work during the World War, and shortly before his death published *Reims dévastée* and *Le Lion d'Arras*. He died in Paris Jan. 7 1920.

**ADAMS, HENRY** (1858-1918), American historian (see 1.175), died in Washington, D.C., May 27 1918. In 1910 his *Letter to*

*American Teachers of History* appeared, and in 1911 his *Life of George Cabot Lodge*. In 1913 his *Mont Saint Michel and Chartres* (privately printed in 1904) was published by authority of the American Institute of Architects, a scholarly interpretation of the architecture and literature of the mediæval Church. In 1918 his autobiographical *The Education of Henry Adams* (privately printed in 1906) was issued for the public. No book of its decade evoked more discussion in America. In 1919 *The Degradation of the Democratic Dogma* (consisting of several essays previously published together with one hitherto unpublished) was issued, with an introduction by his brother, Brooks Adams.

His brother, CHARLES FRANCIS ADAMS (see 1.175), died in Washington, D.C., March 20 1915. In 1911 he published *Studies Military and Diplomatic, 1775-1865*, and in 1913 *Trans-Atlantic Historical Solidarity* (lectures delivered at Oxford).

In 1916 Worthington C. Ford edited *Charles Francis Adams, an Autobiography*, from papers deposited in 1913 with the Massachusetts Historical Society. See also the same editor's *A Cycle of Adams Letters, 1861-1865* (1920).

**ADAMS, MAUDE** (1872- ), American actress, was born in Salt Lake City, Utah, Nov. 11 1872. Her family name was Kiskadden, but she adopted the maiden name, Adams, of her mother, an actress. She early played child's parts, and at the age of 16 went to New York. From her appearance in Hoyt's *A Midnight Bell*, in 1889, her popularity grew steadily. In 1897 she was first starred by Charles Frohman as Lady Babbie in *The Little Minister*; and in many of Barrie's other plays she won applause. She introduced Rostand to the American stage, taking the title-rôle in *L'Aiglon* (1901), and in *Chantecler* (1911). Other plays in her repertoire were *Romeo and Juliet* (1900); *The Pretty Sister of Joseph* (1903); *The Jesters* (1908) and *As You Like It* (1910).

**ADAMSON, WILLIAM** (1863- ), British Labour politician, was born at Halbeath, Fife, April 2 1863. When very young he began to work in the pits, and for many years led the life of a miner. In 1902 he became assistant secretary of the Fife and Kinross Miners' Association, and in 1908 its general secretary. He stood for Parliament unsuccessfully in Jan. 1910, but in Dec. was elected for West Fife. On the reorganization of the Labour party in 1917, Mr. Adamson succeeded Mr. Arthur Henderson as its chairman, and in 1918 he was sworn of the Privy Council. In 1919 the Labour party, as the second strongest combination in the House of Commons, decided to assume the position of the official Opposition, and Mr. Adamson became its leader, taking his seat on the front Opposition bench. As an Opposition leader he also congratulated the Speaker upon his reelection. He took part in the debate on the King's speech, pointing out the views of the Labour party on the industrial situation. Mr. Adamson took a prominent part in the various trade-union discussions in 1919, 1920 and 1921, particularly in the numerous debates on the coal industry in these years.

**ADDAMS, JANE** (1860- ), American sociologist (see 1.183), published *Twenty Years at Hull House* (1910), with much autobiographical comment; *A New Conscience and an Ancient Evil* (1911) and *The Long Road of Women's Memory* (1916). She did much to promote the cause of woman suffrage, and in 1912 was an active worker in behalf of the short-lived National Progressive party. After the outbreak of the World War in Europe she attended the International Congress of Women held at The Hague in 1915, and was elected president. She was also appointed chairman of the International Committee of Women for Permanent Peace. She was an avowed pacifist after America had entered the World War.

**ADDISON, CHRISTOPHER** (1860- ), English politician and medical practitioner, born June 19 1860 at Hogsthorpe, Lincs., was educated at Trinity College, Harrogate, and received his medical training at St. Bartholomew's hospital. He graduated at London University, taking the M.B. (Honours in For. Med.) and the B.S. in 1892, and the M.D. in 1893. He was elected F.R.C.S. in 1895. He became lecturer in Anatomy both at his own hospital and at Charing Cross hospital; professor of Anatomy at University College, Sheffield; and Hunterian

professor at the Royal College of Surgeons in 1901. Besides the private practice of his profession, he contributed largely to medical knowledge by the publication of several books, mainly on the anatomy of the pancreas and the abdominal viscera, by papers in the *Proceedings of the Royal Society* and in professional journals, and by editing for a time the *Quarterly Medical Journal*. He took, moreover, a leading part in medical education in London University, in 1910 he entered Parliament as Liberal member for Hoxton. He immediately became active in the House. In conjunction with Sir George Newman he was mainly instrumental in securing the medical treatment of school children and State provision for medical research; and he was one of the few doctors of distinction who supported Mr. Lloyd George in his struggle with the profession over the Insurance Act (1912). The valuable support he then gave to Mr. Lloyd George in reconciling the doctors to his proposals created a firm bond between him and the future Prime Minister. When in 1914 Mr. Charles Trevelyan, on the outbreak of war, resigned the Parliamentary Secretaryship of the Board of Education, Dr. Addison was appointed in his place. But his principal work during the war was effected at the Ministry of Munitions, where Mr. Lloyd George obtained his assistance as Parliamentary Secretary when the office was created under the first Coalition Ministry in 1915. So long as Mr. Lloyd George was Minister, Dr. Addison was his right-hand man in the strenuous labours of the office, resulting in the enormous multiplication of engines of war, and in the redeeming of many vital industries, fertilizers, tungsten and potash from German control; and when Mr. Lloyd George formed a Government himself in December 1916, he placed him at the head of the department. Dr. Addison had to deal with various labour troubles, and in particular with a serious strike of engineers in May 1917. In July he left the Ministry of Munitions to become Minister of Reconstruction without portfolio. In this new but very important work his policy was apparently influenced by a rather idealistic vision of a "new world" after the war. One result was the unemployment dole, at first a necessity, but afterwards a hindrance to a return to normal life. To promote national health had always been his main object in politics, and when Mr. Lloyd George reconstructed his Ministry in the beginning of 1919, he entrusted the Local Government Board to Dr. Addison, that he might complete Lord Rhondda's work and transform it into a Ministry of Health. This was accomplished in June. He also carried through Parliament an important Housing and Town-Planning bill compelling local authorities to provide housing schemes, and obtained parliamentary sanction to an arrangement for the issue by such authorities of housing bonds. The ambitious medical establishment created by him was subjected to a good deal of criticism on the score of economy during 1920; and on the reconstruction of the Ministry in March 1921 he was transferred from the new department to become once more a minister without portfolio. This position he resigned on July 14. He married in 1902 Isobel Gray, and had two sons and two daughters.

**ADEN** (see 1.190).—The territory comprises the peninsulas of Aden proper and Little Aden, a strip of mainland including the villages of Sheikh 'Utman, 6 m. inland, 'Imad and Hiswa, and Perim Island. The town of Aden and its port Tawahi, 4 m. westward, are connected by a good carriage-road with the Somali settlement of Ma'la about midway. The harbour—known as Bandar Tawiya or Aden-West Bay—lies between the main and Little Aden peninsulas (Jebel Inshan or Hasan); it extends 8 m. from E. to W. and 3 m. from N. to S. and is divided into a western and an inner bay by a spit of land. The depth of water at the main entrance is 4½ to 5 fathoms and in the western bay 3 to 4 fathoms. For lack of docks and quays, large vessels lie off Steamer Point and all cargo is handled by means of lighters, the labour being either Somali or Arab. Sailing and small craft load and unload at Ma'la. The population of Aden proper in 1915 was 36,900 and of the whole settlement 46,000, of whom about 23,000 were Arabs and a large part of the remainder Somalis. European residents and Christians numbered 2,000 to 3,000, Mohammedans about 34,000 and Jews 3,700.

On March 1 1921 the administration of Aden was transferred from the India Office to the Colonial Office, which also exercises political influence, in varying degrees, over the confederations of tribes inhabiting the interior as far as the Yemen frontier and over certain tribes of the Hadhramaut. The revenue in 1914-5 amounted to 87½ lakhs of rupees (approx. £580,000), derived mainly from the Aden Port Trust Fund (£34,000), Aden Settlement Fund (£28,000), Local Supply Bills (£257,000), imperial and municipal receipts (£215,700), Post Office (£34,000), excise, customs and income tax. The expenditure in the same year was £56,000.

The value of the total trade (including specie) amounted to \$8,526,000 (1913-4), and had increased to \$10,045,000 in 1918-9 and £13,641,000 in 1919-20. Of the last amount, £7,124,000 represented exports and £6,517,000 imports. A very large proportion represents simple transshipment; but Aden is also the centre of the exporting and importing business of the Red Sea commercial region made up of the Hejaz, Asir, Yemen, Hadhramaut, Eritrea, Abyssinia and British and French Somaliland. The principal articles of import in 1919-20 were: cotton piece-goods and yarn £2,180,000, hides and skins £1,291,000, coal £626,000, grain and flour £541,000, coffee, sugar, tobacco, hardware, petroleum and provisions. The exports were: hides and skins £2,123,000, cotton goods £2,112,000, coffee £456,000, grain and pulse £329,000, tobacco £213,000 and salt £151,000. Local products, including *kat*, firewood, live animals, *zaf*, dates, honey, wax, gums and sesame oil, to the value of about £125,000, were exported in 1919-20. 1,065 steam vessels of aggregate tonnage 2,736,391 and sailing craft of tonnage 365,569 cleared in the year ending March 1919. The port is free except for a small duty on alcoholic liquors and intoxicating drugs. Licences are required for the importation of petroleum and small arms and ammunition.

The water supply, formerly very uncertain and unsatisfactory, is mainly from reservoirs and from condensation. The reservoirs have a storage capacity of 8,000,000 gal. but the most effective supply is obtained by condensation of sea water. Six condensers yield 52,000 gal. daily.

Aden produces no foodstuffs. The only local industries are the preparation of salt (Italian and Indian concessions, with an output of 124,000 tons in 1916-7), the unhusking of Arabian coffee berries and the making of cigarettes from tobacco imported from Egypt. The main trade routes are:—to San'a, via Lahej, 227 m.; to Mocha and Hodeida, via Ta'izz, 299 m.; and to Makalla, via Nisab, 413 m.

During the World War, Turkey brought pressure to bear on certain of the tribes of the Aden Protectorate (see ARABIA) and in July 1915 a Turkish army several thousand strong advanced on Lahej, the 'Abdali capital (21 m. N.). A small British force sent to assist in its defence proved altogether inadequate and had to retreat to Aden. The Turks occupied Sheikh 'Othman, but were unable to threaten Aden itself. The loyal Sultan was killed. On July 20 of the same year reinforced Aden troops surprised the Turks at Sheikh 'Othman, inflicted on them considerable loss and they retired to Lahej. In Oct. and in Dec. cavalry had small affairs with enemy reconnoitring parties in which the latter were driven off. In Jan. 1916, owing to the Turks again despatching troops to coerce the tribes in the east of the Protectorate, a demonstration in support of the latter was made by the Aden column. It located the enemy force near the village of Subar (4 m. S.S.E. of Lahej), inflicted considerable loss on it, and the Turkish pressure was relieved. In Dec. 1917 the defensive line at Aden described an arc of about 11 m. radius and there had been constant partial skirmishes and small actions which continued until the Armistice.

**ADLER, VIKTOR** (1852-1918), Austrian politician, was born at Prague June 24 1852, the son of a well-to-do business man, who moved with his family to Vienna when the son was three years old. Here he studied at the Schotten-gymnasium, where he gathered round him a circle of fellow-students who thus early began to occupy themselves with political and social questions, their interest having been aroused by the works of Lassalle and by the events of 1866 and 1870. It was at this time, too, that the Social Democratic Labour movement first began to affect Austria. On the basis of the new law respecting combinations, passed during the era of Liberal-bourgeois reform, arose the first proletarian organizations, and the battles between the adherents of state assistance (Lassalle) and of self-help (Schultz-Delitzsch) were being publicly fought out. At the university Adler entered the German national students' association, "Arminia," became a member of the committee of the German Reading Union, and belonged to the national and democratic group of intellectuals who, since the middle of the 'seventies, had grouped themselves around the deputy Schönerer, and had formulated the so-called Linz programme (see also PERNERSTORFER). He studied medicine, attaching himself especially to the psychiatrist Meynert,

and in addition to his medical practice occupied himself with industrial hygiene. In his later career he continued to take special interest in public health questions. Intending to adopt factory inspection as a career, he went in 1883 to study in Switzerland and in London, where he came into close touch with Engels. On his return to Vienna, however, he turned entirely to politics. The Workmen's party, weakened by the general economic depression, by internal dissensions and by police prosecutions, had sunk into political insignificance. In the 'eighties the "Radicals" (Most, Peukert) and the "Moderates" were at daggers drawn. The Government of Count Taaffe, on the other hand, supporting itself on the lower middle classes, which held the balance of votes in Austria and especially in Vienna, introduced legislation for the organization of industry on the guild system. It attempted, indeed, to conciliate the working classes by social-political legislation on the German model, but at the same time used the excuse given by the methods of violence advocated by the Radicals to suspend the ordinary law in Vienna and certain other districts, as a preliminary to anti-Socialist and anti-Anarchist legislation. The ground being thus prepared by the Government, Adler undertook to restore unity in the ranks of Labour. In 1886 appeared his paper *Gleichheit* (Equality), eventually succeeded by the *Arbeiterzeitung*, the principal organ of the Social Democratic party, which Adler continued to conduct till his death. His object was to organize the workmen as a political party, and the best methods seemed to him to be those of public propaganda and open political warfare. The united Labour party (*Arbeiterpartei*) was to keep the socialistic ideal constantly in view, but was not to despise small gains. By his sound judgment, and his exceedingly clever handling of men, he succeeded, in spite of difficulties within and without the party, in reaching the first stage in the path he had marked out by carrying the whole party with him, in the last days of the year 1888, on the basis of a carefully weighed programme at the party meeting held at Hainfeld, Lower Austria. He was able to appear in July 1889 at the first congress of the Second International (of which he was from that time an official) as the representative of the united Austrian party; and the first May Day celebration (1890), the first of those imposing demonstrations by which he sought to give a striking proof of the will and the power of the working classes, showed that a new epoch had dawned for Austrian Social Democracy. Adler, who was repeatedly involved in legal proceedings and condemned to terms of several months' imprisonment for political offences, was from that time the acknowledged leader of the party.

In consequence of the ever-increasing extension of its industrial and political organization, in which Adler took an energetic part, the party obtained an increasing influence in public life, which was further increased by the division of the bourgeois parties on the nationality question. Adler understood how to make the best of these conditions. He regarded it as his first task to secure for the workmen representation in Parliament. After the three years' struggle for electoral reform (1893-6), which followed the proposals for the modification of the franchise put forward by the prime minister, Count Taaffe, some measure of electoral reform was secured. But it was insufficient, and it was only when the Government had decided that an extension of the franchise was the sole means by which the monarchy could be protected against the centrifugal forces of nationality, that Adler was able to see the impression made by the confusions in Hungary and the Russian revolution of 1905 to interpose with all his weight and help to secure the triumph of universal and equal suffrage (1907).

The Social Democratic party increased their representation from 11 deputies to 87. Adler himself entered the Diet of Lower Austria in 1902, and in 1905 was elected to the Reichsrat, where until his death he played an important part as chairman of the committee of the Social Democratic party and of the Social Democratic Deputies' Club, taking part in all important debates.

New dangers, due to the nature of the Austrian State with its rival nationalities, more than once threatened the unity of the



party. Adler had always been a Pan-German, but regarded the disruption of Austria and the union of German Austria with Germany as a distant goal which had no place in the practical politics of the moment. He aimed therefore at establishing a friendly relation between the nations on the basis of democracy. When the Austrian Germans were threatened by the language ordinance of Count Badeni, and Parliament itself by a *coup d'état*, Adler made an alliance with the German parties, rallied the working classes, and overthrew the Polish prime minister (1897). At the party congresses, Adler tried to accommodate the conflicting national standpoints on the basis of the principles laid down in the Brünn programme (equal rights and national autonomy). But the unified organization of the trade unions and the union of the Social Democratic parties were destroyed in consequence of these differences, more especially by the intransigence of the Czechs. No general party congress of the different Austrian nationalities has taken place since 1905.

In the congresses and in the secretariat of the International Adler, with Jaurès and Bebel, played the most prominent part, whether as leader, adviser, or mediator. He took part in the great peace demonstration of the International at Basel, and in the meeting of the secretariat in Brussels immediately before the outbreak of the World War. In spite of bad health, which for many years in succession had compelled him to spend much time on the Riviera and at Nauheim, he travelled in the spring of 1917, immediately after the trial of his son Friedrich, to Stockholm to the proposed Socialist congress. After the collapse of Austria in 1918, at the constituent session of the provisional German-Austrian National Assembly, which was formed by the meeting of all the German deputies, he read the declaration of the Social Democrats, in which they expressed their willingness, in association with the other German-Austrian parties, to build the new State on the basis of democracy and the self-determination of their own and other nationalities, without prejudice to a possible association with the German Empire.

In his opening words Adler said: "You will permit an old man to say that at last we see the accomplishment of what we have longed for since our youth." He did not long survive that day. He held for a few days the office of Foreign Minister, entrusted to him by the new State Council (*Staatsrat*), but in spite of his iron determination he was not able to bear the strain. He broke down on Nov. 11 and died on the 17th, 1918, the day on which the State Council had decided to proclaim German Austria a democratic republic and an integral part of the German Reich.

His works include articles scattered in various newspapers, in the *Neue Zeit*, *Kampf*, *Deutsche Worte*, in addition to those in the *Arbeiterzeitung*; pamphlets, among which are *Die Fabrikinspektion*, *insbesondere in England und der Schweiz* (1884); *Die Arbeiterkammer und die Arbeiter* (1886); *Das allgemeine, gleiche und direkte Wahlrecht und das Wahlrecht in Oesterreich*; *Alcoholismus und Gewerkschaft* (many editions). See also *Die Gleichheit vor dem Ausnahmegericht* (1889); *Schwurgerichtsprozess gegen Doktor Viktor Adler wegen Verbrechens der Störung der öffentlichen Ruhe* (1894).

His son, FRIEDRICH ADLER (1879- ), Austrian politician, was born on Vienna July 9 1879. He was educated at the Realgymnasium in Vienna, and studied philosophy at the university of Zurich. He was privatdozent (lecturer by diploma) in physics at the university of Zurich from 1907 to 1911, editor of the Social Democratic daily *Volkrecht* from 1910 to 1911, and from 1911 to 1916 secretary of the Austrian Social Democratic party and editor of the monthly *Kampf*. During the World War he was in sympathy with the conclusions reached at the conferences of the Socialists of the Left at Zimmerwald and Kienthal. In despair over the break-up of the International, he shot (Oct. 21 1916) the Austrian prime minister, Count Stürgkh, in the expectation that the deed would be a signal for the rising of the proletariat against the war. After a speech in his own defence which aroused much attention he was, on May 19 1917, condemned by a special tribunal to death, a sentence commuted to 18 years' imprisonment. During the chaos of the autumn of 1918 he was amnestied (Nov. 1). In 1919 he was elected to the National Assembly, and became vice-president of the committee of the Social Democratic party and

of the Union of the Social Democratic deputies. As president of the Austrian National Workmen's Council and of the Vienna District Workmen's Council he exercised great influence in the party. On his initiative was founded the International Labour Association of Socialist Parties, of which the first meeting was held in Vienna in Feb. 1921. He made the opening statement, and became secretary of the Association.

His works are: *Die Erneuerung der Internationale* (1918); *Ernst Mach's Ueberwindung des mechanischen Materialismus* (1918); *Ortszeit, Systemszeit, Lenzzeit und das ausgezeichnete Bezugssystem der Electrodynamik, eine Untersuchung über die Lorentzische und die Einsteinsche Kinematik* (1920). See also *Friedrich Adler vor dem Ausnahmegericht* (1919).

**ADMIRALTY ADMINISTRATION** (see 1.195).—The history of the British Admiralty during the World War of 1914-8 is the history of the evolution of the naval staff and of a great expansion of the technical and administrative departments. All departments expanded during the war, but the evolution of the naval staff was more than mere expansion, for it represented the adoption of definite principles of staff work which were intended to prevent those responsible for the conduct of naval operations being crushed under a load of administrative business.

This was, indeed, no new trouble. It had been experienced ashore and afloat in peace and war. Kempenfelt and Tryon had commented strongly on it. "We are every day," wrote the former to Middleton in 1770, "plagued and puzzled with minutiae from morning to night whilst essentials are neglected." "It cannot be right," wrote Tryon in 1890, "that the Commander-in-Chief should find himself devoting his time to coaling and watering, provisioning, storing and repairing." They were seeking after a solution of the difficulty which lay in a clear distinction between fighting and supply, between the use of the weapon, and its supply and maintenance in an efficient state. This principle had been introduced into the British army by Lord Haldane, and is equally applicable to naval work. It is a principle vital to war, for on the outbreak of war the whole rhythm of work changes. Work expands tenfold in extent and an hundredfold in urgency, and without some clear distinction of this sort it is impossible to give to the conduct of operations the attention it deserves.

The principle was not to be found in the British Admiralty at the beginning of the war. The First Sea Lord was just as interested in the design of ships as in operations, and the War Staff lacked some of the most important elements of staff work. The important distinction between fighting and supply was not to be found; the Chief of the War Staff had no seat on the Board, and the methods of conducting the work of a large staff had not been studied. Up to 1909 the Intelligence Department had to some extent filled the place of a staff. It had gradually grown from the Foreign Intelligence Branch or Committee instituted in 1883, and had developed into the Naval Intelligence Department, consisting of four divisions—foreign, trade, mobilization and war—of which the two latter were evidently tentative efforts towards an Operations Division. In Sept. 1909 it split into two separate departments, intelligence and mobilization, of which the latter was clearly the beginning of an Operations Division, but was killed by its name, for it soon became immersed in the task of manning and mobilization, which belongs wholly to the sphere of supply. The Intelligence Department sank more and more into the position of a mere handmaid for the collection of data and translations from the foreign press. Its development was hampered by the intense suspicion with which most flag officers regarded anything that seemed to trespass on their prerogative of command. The idea of a staff was held in great disfavour. The word was anathema at the Admiralty and not allowed to be used in War College publications, and it is no secret that the most distinguished flag officers were opposed to the institution of a staff in 1912.

The naval staff really dates from the Memorandum of Jan. 1912 issued by Mr. Churchill, after the breakdown of the old system at the Agadir crisis, but it had not had sufficient time to develop before the World War broke on it and broke it up. It consisted of three small divisions—operations, intelligence

and mobilization. Its deficiencies may be briefly summarised: Firstly, the Chief of the War Staff was not a member of the Board, and could not act with Board authority; his function was merely advisory. Secondly, there was a great insufficiency of trained staff officers, and the War Staff proved quite inadequate in numbers and training to deal with the business of war. Thirdly, the principles of staff work had not been studied, and the vital distinction between fighting and supply was not to be found. Fourthly, the system found little support either at Whitehall or in the fleet at sea. There was no clear conception of conducting the work of a staff, or of grafting it on to the business system of the Admiralty. On the first day of war a number of sections were bundled into one big room in order to be as close as possible to one another to the serious dislocation of their work. The Operations Division was divided on the basis of types of ships rather than of areas. It soon became absorbed in current work, and had no time for the examination of large plans, which might require three months' work merely to reduce to terms of time and supply. The enormous importance to a staff of an operations chart clearly and continuously visualizing the situation was not appreciated. An operations chart was started, but gradually over-centralization and the obsession of secrecy came down on it like a thick fog and turned it into a fiasco. The movements of transports were kept a profound secret, and news of them was withheld. Secret telegrams (pink telegrams) were started about Nov. 1914 but were not passed to the War Room to be plotted on the chart; which degenerated into a paltry record of reports of mines sighted round the coast. Up to 1917 there was no chart to which a staff officer could go and see at a glance the actual situation at the moment in any and every area.

The work which ought to have been done by the staff was done by a small group of two or three flag officers acting in an advisory capacity to the Board, and the system seemed to be designed for the special purpose of making it as difficult as possible to obtain information. The Intelligence Division was expanding and developing under Capt. (later Adml. Sir) William R. Hall, but its sections had to fight hard to obtain information as to British movements. The flag officers worked for the Board, not for the staff, and no one quite knew what they did or where they did it.

Let us consider the constitution of the Admiralty Board when the war broke out. Under a patent of Dec. 1 1913 it consisted of the First Lord, Mr. Winston Spencer Churchill (since Oct. 24 1911), Adml. Prince Louis of Battenberg (1st S.L., since Dec. 9 1912), Vice-Adml. Sir Frederick Hamilton (2nd S.L.), who had succeeded Vice-Adml. Sir John Jellicoe (July 30 1914), Rear-Adml. Archibald G. H. Moore (3rd S.L., since May 29 1912), Capt. Cecil F. Lambert (4th S.L., since Dec. 1 1913), Mr. George Lambert, M.P. (Civil Lord, since Dec. 21 1905), Sir Francis J. S. Hopwood (Parliamentary and Financial Secretary since Jan. 18 1912, later created Lord Southborough), with Sir Graham Greene as Permanent Secretary. Its business was governed by an Order in Council of Aug. 10 1904, which made the First Lord responsible to His Majesty and Parliament for all the business of the Admiralty, and from time to time with his sanction various memoranda were issued regulating the distribution of business. The distribution of business had remained materially the same for many years, though the memorandum actually in force at the outbreak of war was dated Jan. 1914.

The First Sea Lord was responsible for advising on preparations for war, for the fighting and sea-going efficiency of the fleet, and for the superintendence of the War Staff. The 2nd Sea Lord was responsible for personnel; the 3rd Sea Lord for materials; the 4th Sea Lord for transport and stores, full and half pay, salvage and collisions. No one was specially responsible for the conduct of all operations of war, and though this presumably rested with the Chief of the War Staff he was not a member of the Board, and at least two flag officers senior to him were acting in an advisory capacity to the Board. The First Sea Lord was responsible for the "fighting efficiency of

the fleet," a phrase covering an immense technical scope and opening out an endless vista of all sorts of considerations.

It is interesting to observe that the distinction between fighting and supply, which lies at the basis of modern staff organization, existed in a simpler form in the organization of Henry VIII., which continued in force in the British navy down to 1832. In this organization the Lord High Admiral or Commissioners of the Admiralty exercised the function of general control and was responsible for the conduct of a war, while the actual supply services were performed by four principal officers, namely, the Treasurer, Comptroller, Surveyor and Clerk of the Acts, responsible respectively for finance, supervision of accounts, building and upkeep of ships, and record of business. These officials came to be known as the Navy Board, and the organization of the Admiralty from 1546 to 1832 was roughly as follows—

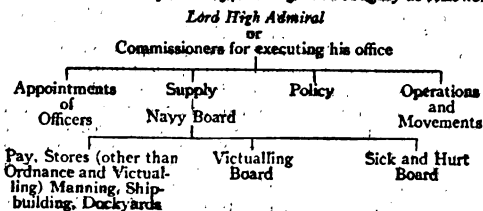

Here the work of supply is kept distinct from the business of fighting, and it was under this dual organization, in which the Navy Board was responsible for the multifarious requirements of war, that the earlier wars were fought.

Unfortunately, the supply system was often bad and insufficient and corrupt, though its defects were due just as much to limitations of the time as to the system! The work was not closely coördinated, with the result that Sir James Graham in 1832 merged the functions of the Navy Board and the Admiralty, an amalgamation which was regarded as a master stroke at the time and had distinct advantages, but unfortunately neglected to retain the principle of distinction between the Admiralty and supply, with the result that it was not the Admiralty that swallowed the Navy Board but the Navy Board that swallowed the Admiralty. The general constitution of the Board, though it varied from time to time, may be represented as follows:—

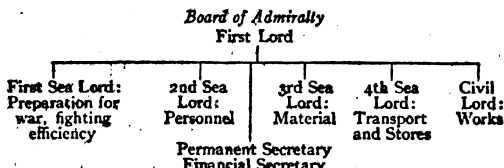

*Note.*—According to the Order in Council of Aug. 1904 the First Lord is practically supreme as being responsible to the King and Parliament, but according to the terms of the Patent "two or any more of you" can exercise the office.

In 1860 commenced that vast multiplication and development of technical crafts and branches which began with the steam engine (the last sailing ship of the time, the *Ganges*, was paid off in 1861), and exercised an enormous influence on the navy and naval thought. The result in conjunction with Sir James Graham's amalgamation was inevitable. Between 1860 and 1900 the study of strategy and of staff work, which is the business side of war, was practically ignored. All the talent and brains of the navy flowed to the great technical schools. The whole trend of thought for forty years was exclusively technical. It was supposed that war and the conduct of war was quite a simple matter for any flag officer and needed no study. This simple creed received a rude shock at the time of the Agadir crisis when the Admiralty plans for war were torn to shreds by the General Staff. A War Staff was then instituted. But the War Staff had hardly been weaned and had not yet found its

feet when the World War broke out. It laboured under a further handicap: practically all senior officers were opposed to it. They were wedded to centralization. Centralization had become engrained in their bones from boyhood, and their whole outlook was necessarily opposed to a staff. The deficiencies of the system could be seen in the conduct of the Dardanelles campaign. It is clear that there was no machinery for the intensive investigation of a big strategical question. The First Lord was impressed with an exaggerated estimate of the Queen Elizabeth's guns, and the War Staff could neither supply a sufficiently trenchant criticism of the project nor could they grip the problem and transform it into a workable proposition by segregating a force and training it as the Zeebrugge force was afterwards trained.

Enough has been said to show that the war staff lacked the staff spirit, and a knowledge of the principles of staff organization and of the conduct of staff work. One bright spot, however, shone in it. While the operations side became more and more narrowly centralized, the intelligence side, under Sir William Hall, summoned a vast reserve of civilian talent to its aid. Very early in the war a system of special intelligence based on wireless directionals had begun to develop, and though cramped and restricted by the obsession of secrecy had proved of great value. In Dec. 1916, when Adml. Sir John Jellicoe came to the Admiralty, he instituted an anti-submarine division, which was no more than a belated plans division directed to a special purpose, but it was not till 1917 that the staff was thoroughly reorganized and really began to function as a staff. In Dec. 1916 it was organized as follows:—

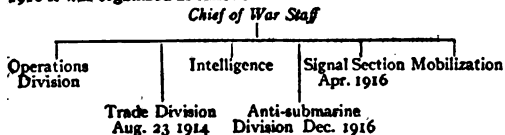

Sir Eric Geddes gave an immense impetus to the system, which was forced upon the Government by the exigencies of war, and in its main outlines was merely the system of Moltke, Lord Haldane, and every modern army, adapted to naval needs. These can be briefly summarized as follows. The work of a staff follows three lines of practical cleavage: (a) operations (or direction) enshrines the main purpose of a business; administration is responsible for its maintenance and equipment in an efficient state; technical control deals with the scientific aspect of applied sciences associated with the business. Finance and the Secretariat interpenetrate the whole. Operations (or direction) is the premier function, and splits into two main divisions, operations (minor) and intelligence. It is the special task of operations to appreciate the situation continuously, to assist the Command in the consideration of requirements and with the preparation and conduct of operations, and to convert the intentions, policy and decisions of the Command into orders and instructions. It is its business to visualize the situation continuously on an operations chart and to furnish all branches and technical services with timely information of all requirements. The function of intelligence is to collect, sift and distribute information of the enemy, and by the cumulative intelligence arising out of its work to help operations to appreciate

the situation. Administration and technical comprise all the great services of supply and technical work, including personnel, pay, victualling, stores, transport, and the crafts of hydrography and surveying, navigation, marine engineering, naval construction, gunnery, torpedoes, mine-laying, mine-sweeping and signals. Each service is responsible for its internal efficiency, and the Chief of the Staff is responsible for the co-ordination of all, while to assist him in this a training and staff division is required which acts as the trustee of staff principle and organization and is also responsible for staff training, principles of training, staff history and manuals of war. No one of the three great branches is more important than another. Like the brain, heart and lungs, all are complementary to each other. If there are no ships there can be no operations; if the operations are badly conducted, the best ships will be useless; a new technical invention may revolutionize operations, and the whole service must rest on a basis of good discipline and sound financial administration.

The first step towards these principles was really taken in May 1917, when the term "War Staff" was altered to "Naval Staff" and the office of Chief of the Naval Staff was merged in the First Sea Lord (Admiral Jellicoe), while a Deputy Chief of the Naval Staff (Vice-Admiral Oliver) and an Assistant Chief (Rear-Admiral Duff) were appointed with seats on the Board. This gave the naval staff direct representation on the Board, and the presence of three members ensured the necessary authority to carry through any operation of war. The D.C.N.S. directed all operations and movements of the fleet, while the A.C.N.S. was responsible for mercantile movements and anti-submarine operations.

The office of Controller was revived, and Sir Eric Geddes appointed to fill it, with the rank of Honorary Vice-Admiral, all questions of supply being thus practically merged in his hands; but he had barely filled the office two months when he took Sir Edward Carson's place as First Lord July 30 1917. On Sept. 6 1917 a Deputy First Sea Lord, Sir Roslyn Wemyss, was added to the Board to control operations abroad and questions of foreign policy. Sir Oswyn Murray too had succeeded Sir Graham Greene as Permanent Secretary in Aug. 1917.

In Oct. 1917 the development of the staff was carried one step further by the formation on Oct. 19 of two Committees of the Board—the Operations Committee and the Maintenance Committee. The First Lord was chairman of both, and the former consisted of the First Sea Lord and C.N.S., the Deputy 1st S.L., D.C.N.S., A.C.N.S., and 5th Sea Lord. The latter consisted of the Deputy 1st S.L. (representing the operations committee), 2nd S.L. (personnel), 3rd S.L. (material), 4th S.L. (transport and stores), Civil Lord, Controller and Financial Secretary.

The direction of operations was finally handed over to the C.N.S. by an order in Council of Oct. 1917, under which he became responsible for the issue of orders affecting war operations to the fleet. It empowered such orders to be issued in his own name as C.N.S., and not as previously by the secretary in the name of the Board.

These measures were accompanied by the institution of further divisions of the staff, including a plans division, and by Oct. 1917 the Board and naval staff had assumed the following form:—

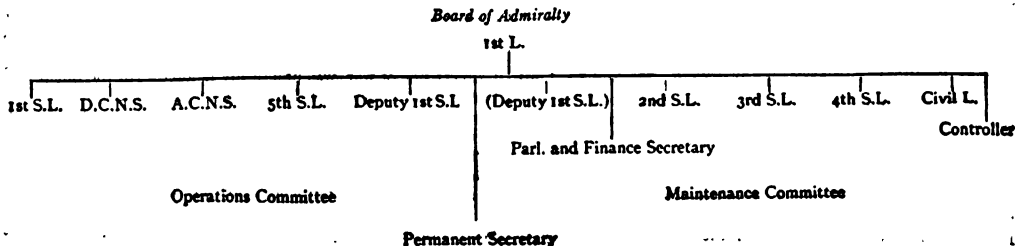

*Naval Staff*  
C.N.S. and 1st S.L. (Adml. Jellicoe)

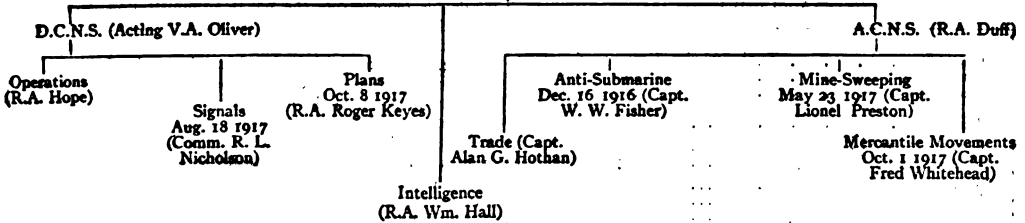

One of the most important divisions of the naval staff was the mercantile movements division, which had been started as a convoy section, under the management of Paymaster Capt. H. W. Manisty. It was here in May 1917 that an operations chart came into use for the direction of convoys, on which the movements of submarines derived from wireless directionals and other reports were plotted, day and night. Operations divisions, troubled like Martha over many things, had never been able to deal in big plans, and this work was undertaken by the plans division which drew up plans for the mining of the Bight, the Great Northern Barrage (in conjunction with the U.S. navy), the Dover Barrage, the Otranto Barrage and numerous smaller operations.

The ease with which the distinction between operations and administration can be applied is illustrated in the submarine and auxiliary patrol services. In both these services the administrative work (such as regulations, conditions of entry, stores, personnel) was dealt with by a centre which had very little or nothing whatever to do with operations (Commodore (S) in the one case and the Auxiliary Patrol Office in the other), and the system worked very successfully from first to last. The reorganization of staff work was not limited to the Admiralty. It extended to every command, and in April 1918 the First Lord and Rear-Adml. Sir W. R. Hall proceeded to Malta and made arrangements for the entire reorganization of the C-in-C.'s staff, leading to a great reduction in shipping losses in the Mediterranean.

With the advent of peace the naval staff was greatly reduced, and some divisions naturally disappeared. A change of some importance has taken place in the function of the A.C.N.S., who has become responsible for all staff questions relating to technical branches and crafts such as gunnery, torpedoes and mining. Gunnery and torpedo divisions have been introduced into the staff to deal with questions of the tactical use of these weapons and the training of personnel. The plea for this lies in the close connexion between the use of the weapon and operations. There can be no doubt that training and the tactical aspects of weapons constitute a sphere common to the naval staff, the great technical departments and the fleet, but though they certainly require to be in close touch with the naval staff it still remains a moot point whether all technical crafts with the training that belongs to them should not be segregated from the naval staff.

The distribution of the naval staff in 1921 was as follows:—

1st S.L. and C.N.S.



**Secretariat and Staff Registries.**

The duties of the C.N.S. and principal officers are as follow:—

C.N.S.—All large questions of naval policy and maritime warfare organizations, distribution, and fighting sea-going efficiency of the fleet. Advice as to general direction of operations of war. Inter-

nal organization and general direction of the work of the naval staff and coöperation of the naval staff with the material side of the Admiralty.

D.C.N.S.—Operations and movements, naval intelligence, strategy policy and plans. Sea-borne trade and international law.

A.C.N.S.—Methods of fighting at sea. Design in relation to policy and tactics. Staff questions of research. Air development in relation to naval warfare.

Little has been said here of the civil side of the Admiralty because it runs through and interpenetrates every branch. The more essentially civilian branches, such as naval stores and victualling, were among the most efficient of the war. There is sometimes a tendency to talk of the Admiralty as a place where, through civilian-agency, the best naval plans "gang aft agley." This is a complete fallacy. Admirals have played a great part in the Admiralty and in its history, past and present, and cannot dissociate themselves from its work. If the Admiralty in the war made mistakes, the navy and its admirals must share the blame, and in the final victory a portion of the laurels belong to the Admiralty and the civil servants of the King.

The strength of the naval staff divisions and departments in the British Admiralty is shown, as for the crucial dates under the war reorganization, in the table on p. 10. (A. C. D.)

UNITED STATES.—After 1909 various measures providing for a reorganization of the U.S. Navy Department were brought forward, but for several years Congress failed to take any action, though certain proposals, notably the recommendations of the board appointed by President Taft in 1909, were strongly urged. The organization of the Department as then constituted had been the subject of criticism by a number of secretaries of the navy as well as by others; the chief defect was the lack of some agency to perform the functions of a general staff in the conduct of naval operations. It is true that since 1900 the secretary had had the deliberations and reports of the general board to guide him, but this board had no executive powers, and in the last analysis the responsibility for coördinating the activities of some eight different bureaus rested solely on the secretary of the navy. In default of legislation, Secretary Meyer made an effort in 1913 to remedy this condition by the issuance of regulations providing for the appointment of an aid for operations, an aid for personnel, an aid for material, and an aid for inspections, who were to be officers of the navy on the active list not below the grade of captain and who were to constitute an advisory council charged with the duty of

promoting effective coöperation in the work of the Department. Under Secretary Daniels, who succeeded Secretary Meyer in 1913, the offices of aid for personnel and aid for inspections were discontinued, but there was created the office of aid for

BRITISH ADMIRALTY STAFF, 1914-1918

(An asterisk denotes divisions and departments in existence April 1917.)

	1914	Nov. 1918
<b>Naval Staff:—</b>		
*Operations . . . . .	7	24
*Intelligence . . . . .	16	140 (45 unpaid)
Mobilization . . . . .	4	to maintenance side
*Trade . . . . .	...	37
Anti-submarine } merged in	...	40
Mine-sweeping } Local	...	7
*Signals (now Signal Dept.)	...	28
*Plans . . . . .	...	11
Mercantile Movements (lapsed)	...	39
*Training and Staff Duties	...	6
*Local Defence Div'n (post war)	...	nil
*Gunnery Division . . . . .	...	4
*Torpedo Division (post war)	...	nil
<b>Total</b> . . . . .	<b>27</b>	<b>336</b>
<b>Secretariat:—</b>		
Secretary . . . . .	45	80 (2 unpaid)
Chief Censor . . . . .	19	19
Publicity . . . . .	...	25
*Statistics . . . . .	...	12
<b>Total</b> . . . . .	<b>45</b>	<b>136</b>
<b>Personnel:—</b>		
*Mobilization . . . . .	Naval Staff	17
*Recruiting . . . . .	...	10
*Royal Marine Office . . . . .	10	15
*Paymaster Director General	...	4
*Admiral of Training (post war)	...	..
Physical Training and Sports	...	..
*Naval Education . . . . .	5	5
*Chaplain of the Fleet . . . . .	2	2
*Medical Director General	10	16
<b>Total</b> . . . . .	<b>27</b>	<b>69</b>
<b>Technical:—</b>		
*Hydrographer . . . . .	35	58
*Navigation . . . . .	3	6
*Naval Construction . . . . .	68	94
*Naval Engineer-in-Chief	27	48
*Electrical Engineering . . . . .	...	32
*Naval Ordnance . . . . .	53 (and torpedoes)	245
*Torpedoes and Mining . . . . .	...	117
*Naval Equipment . . . . .	10	60
*Compass Department . . . . .	3	37
*Dockyards and Shipbuilding (Director of Dockyards)	...	50
Warship Production . . . . .	...	99
Auxiliary Vessels . . . . .	...	46
*Armament Production (now Armament Supply)	...	49
Airship Production . . . . .	...	57
Finance Division . . . . .	...	21
Costings Division . . . . .	...	86
General Merchant Shipbuilding	...	165
Admiralty Labour Dept. . . . .	...	146
Materials and Priority . . . . .	...	106
*Research and Experiment . . . . .	...	67
*Works . . . . .	103	229
<b>Total</b> . . . . .	<b>302</b>	<b>1,818</b>
<b>Supply:—</b>		
*Stores . . . . .	36	97
*Vicualling . . . . .	19	30
*Transport . . . . .	31	116 (4 unpaid)
<b>Total</b> . . . . .	<b>86</b>	<b>243</b>
<b>Finance:—</b>		
*Accountant General . . . . .	110	297 (1 unpaid)
*Contract and Purchase . . . . .	46	112
*Greenwich Hospital . . . . .	7	7
<b>Total</b> . . . . .	<b>163</b>	<b>416</b>
<b>Summary:—</b>		
Naval Staff . . . . .	27	336
Secretariat . . . . .	45	136
Personnel . . . . .	27	69
Technical } Maintenance	302	1,818
Supply	86	243
Finance	163	416
<b>Grand Total</b> . . . . .	<b>650</b>	<b>3,018</b>

education, whose duties were concerned with the Secretary's programme for furnishing free instruction to enlisted men.

The outbreak of the World War gave new force to the proposals for reorganizing the naval administration, and by the Act of March 3 1915 Congress created the office of chief of naval operations, the incumbent of which by the subsequent Act of Aug. 29 1916, was promoted to the rank of admiral and assigned 15 officers above the rank of lieutenant-commander of the navy or major of the marine corps as assistants. The chief of naval operations was "charged with the operations of the fleet and with preparation and readiness of plans for its use in war." By regulation his duties were defined as including the direction of all strategic and tactical matters, organization, manoeuvres, target practice, drills and exercises and the training of the fleet for war. Under his direction were also placed the Naval War College at Newport, the office of naval intelligence, the office of gunnery exercises and engineering performances, the operation of the radio service and other systems of communication, the aeronautics service, the division of mines and mining, the naval defence districts and the coastguard when operating with the navy. The duties of the previously existing bureaus were limited to activities subordinate to military operations. By the Act of June 30 1914, these bureaus had been reduced to seven, the bureau of equipment having been abolished and its duties distributed among the other bureaus. The value of the new method of organization became almost immediately apparent; within 10 months after the passage of the first Act (1915) plans for the mobilization of the U.S. naval force were approved and ready to put into effect. Thus, when the United States entered the World War the Navy Department was, from the administrative standpoint, well prepared to undertake its new duties and responsibilities. In his report for 1918 Secretary Daniels stated that the war had necessitated no change in the organization of the Department, which had easily expanded to meet the emergency. During the war the Navy Department had the assistance of the War Industries Board, the Council of National Defense, the National Research Council, the Aircraft Production Board and the Naval Consulting Board.

The Naval Consulting Board, composed of civilian inventors and engineers, was first established in 1915 with Thomas A. Edison as chairman. It was a voluntary body whose function was to give expert advice when called upon. Secretary Daniels also established an advisory council composed of the Assistant Secretary of the Navy, the chief of naval operations, the chiefs of bureaus, the major-general commandant of the marine corps and the judge-advocate general of the Navy Department.

Secretary Daniels' interest in education for enlisted men has already been noted. An order issued by the Navy Department in Dec. 1913 provided for instruction of enlisted men, petty officers and warrant officers serving on board ship, the purpose being partly to supply deficiencies in school training and partly to fit them for promotion. Training was also instituted at the various naval stations, and schools for assistant paymasters, yeomen, cooks, bakers, commissary stewards, hospital apprentices, machinists' mates, musicians, mess attendants, painters, plumbers, electricians, blacksmiths, and carpenters were maintained. Thus enlisted men could prepare themselves to engage in civil trades at the end of their period of navy service. With the outbreak of the war much of this educational work was temporarily suspended. By the Act of Dec. 20 1917 the number of midshipmen at the U.S. Naval Academy was fixed as follows—five for each senator, representative and delegate in Congress, one for Porto Rico, two for the District of Columbia, 15 appointed each year at large, and 100 appointed annually from enlisted men of the navy. As a war measure the President was authorized in 1918 to reduce the course of instruction at the Academy from four to three years; in 1919, however, the full four-year course was resumed. During the participation of the United States in the World War three training camps for officers of the marine corps were held. In accordance with the Naval Militia Act of 1914 various states organized divisions known as the U.S. Naval Volunteers, to which were assigned naval officers as instructor-inspectors of the militia. A later Act (Aug. 29 1916) created the U.S. Naval Reserve force, with which, in 1918, the naval militia was amalgamated. The Act of 1916 also provided for a Naval Flying Corps, for special engineering officers, for Naval Dental and Dental Reserve Corps, and for taking over the lighthouse service in time of war.

The Naval Appropriations Act of 1915 repeated section 9 of the Personnel Act of March 3 1899, which authorized the retiring of,

officers in certain circumstances for the purpose of accelerating promotion. As a result there were no means of promotion in the commissioned personnel of the navy except through vacancies created by death or statutory age-limit retirements. In 1917, however, a new law changed promotion by seniority, so that line officers above the rank of lieutenant-commander were promoted by selection, the question of proved ability being the controlling consideration. Much comment was aroused in 1919 when a new fleet organization was put into effect, by which two divisions of practically equal strength, the Atlantic fleet and the Pacific fleet, each having a commander-in-chief of the rank of admiral, were created. Some critics regarded this as a violation of the principle enunciated by Admiral Mahan that the fleet should never be divided. Secretary Daniels stated that with the Panama Canal open the two fleets could effect a junction in either ocean and "carry out the plans already formulated for operating as one fleet before any enemy could try conclusions with us."

**ADOR, GUSTAVE** (1845- ), Swiss statesman, a member of a family of Vaud, which in 1814 obtained the burghership of Geneva, and grandson of Jean Pierre Ador, who first obtained this right, was born at Geneva Dec. 23 1845. He studied law at the academy (now the university) of Geneva and in 1868 became an advocate. In 1871 he started his political career as member of the communal council of Cologny, and was twice mayor, in 1878-9 and 1883-5. He was a member of the cantonal Parliament 1874-6, and continuously from 1878 to 1915 save for a short break in 1902. In 1878-9 he represented Geneva in the Swiss Conseil des États. Then he became a member of the executive of the canton of Geneva, being put in charge of the Department of Justice and Police. He resigned after an unfavourable election in 1880, but once more became member of the cantonal executive in 1885, and for 12 years had charge of the cantonal finances. In 1889 he became a member of the Swiss Conseil National, and remained so till 1917, being elected its president in 1901. He was president of the cantonal executive in 1890, 1892, and 1896. In 1894 he became lieutenant-colonel in the Swiss army. In 1914 he founded in Geneva the association for facilitating communications between prisoners-of-war and the central Geneva agency, and succeeded in giving this enterprise great importance and a wide-spread extension. After the enforced resignation of Arthur Hoffmann, Ador, in order to soothe the Entente, became a federal councillor or member of the Federal Executive in June 1917 and was entrusted with the Department of Foreign Affairs. Towards the end of 1918 he was elected by Parliament to be the Swiss President for 1919, but retired from the Federal Executive at the end of his year of office.

**ADVERTISEMENT** (see 1.235).—The great public service rendered by advertising during the World War was one of the most striking features of the progress made in this form of business during the decade 1910-20.

Before 1915 no Government in modern times had attempted to raise subscriptions to a loan through the persuasive methods of commercial advertising on a large scale. The custom was merely to publish the prospectus, and leave it to the investor to form his judgment of its merits. It was not till the floating of the 4½% War Loan in 1915 that the British Government took any definite steps to depart from precedent. At an early stage in its subscription, when it was feared that the result would not be as good as had been hoped for, a Treasury official asked the advice of a well-known London journalist, and at his suggestion it was decided to spend £100,000 in advertising under his direction. A little more than £60,000 was actually spent in advertising, and the subscriptions to the loan eventually realized nearly £600,000,000. Later, this new departure was followed, but only after stereotyped official methods had again proved inadequate, in the campaigns for National War Bonds after Dec. 1916, by a considerable extension of advertising, while in the United States it was freely employed in the raising of the Liberty Loans (see WAR LOANS PUBLICITY CAMPAIGNS).

Before this, advertising by poster had been employed effectively in England to gain enlistments for the army. In this connexion, and in the loan advertising of 1915 and following years, both in Great Britain and America, advertising reached an effectiveness and power that had never been imagined. It is true that the subject dealt with was in everyone's mind; the appeal was to patriotism, to emotion as well as to cold reason

and self-interest. The interests of the writer and of the reader of the advertisements were identical. Even so, the results were amazing. In 1917 a leading American banker said it was impossible to float a loan of \$3,000,000,000 because there were "only 275,000 investors in the country." But after widespread advertising there were more than 6,000,000 individual subscribers to this loan, and the amount was greatly over-subscribed. For the last of the American war loans, the "Victory Loan" floated after the Armistice, nearly 21,000,000 subscribers were obtained—one for every five of the country's population, including women and children.

War advertising enlisted much new talent in writing and illustrating. The foremost artists and writers on both sides of the Atlantic volunteered their services and competed for the honour of having their productions used. With professional advertising men, printers, engravers and lithographers all giving their best, the result was an excellence in form and character that had never been achieved before. While the tide of patriotic emotion raised by the war brought new resources to advertising, their proper application would not have been possible without the knowledge gained in advertising for ordinary business purposes during previous years (see PROPAGANDA).

In the years before 1915 remarkable advances had been made. The number of articles of trade-marked, advertised merchandise had increased rapidly. Stimulated by advertising revenue, scores of weekly and monthly publications had obtained circulation running into hundreds of thousands, and some had passed the million mark. Great daily newspapers had a similar growth and could afford to sell their copies at a price which did not pay for the paper on which they were printed. Posters and advertising signs had passed from their former rude state to a high degree of attractiveness.

At the same time came a remarkable improvement in the character of advertising. Misleading advertisements and advertising of questionable merchandise or of uncertain financial offers were gradually weeded out. Publications found it unprofitable to accept advertising that was offensive to their better clients. The Association of Advertising Clubs of the World adopted "Truth in Advertising" as their slogan, and vigilance committees were appointed to eradicate misleading or untruthful advertising of whatever products. Advertising had become a business of high principles and well-defined ethics. One of the most powerful influences in the development of advertising along sound business and ethical lines was the advertising agency. Beginning more than half a century before as an agency for the selling of space in publications, the modern advertising agency grew into a service institution, acting on behalf of its clients in planning advertising campaigns, selecting the mediums to be used, preparing advertisements, attending to all the details of engraving, type-setting and plate-making and performing many other incidental services. The advertising agency attracted well-educated young men in increasing numbers and represented a recognized field for the employment of talent.

All advertising is more or less a competition for public attention. As the volume of advertising increased the competition became more keen, and resulted in improvement of both the writing and artistic treatment of advertisements. One of the most notable features in recent years has been the use of illustrations in colour, made possible by improved processes of colour-engraving and by the perfection of high-speed colour printing presses. One popular magazine in America, with a circulation approaching two million, has contained more than 50 full-page advertisements in colour in a single issue. Every one of these pages was printed by four-colour process, and gave a faithful reproduction of the subject. This has made it possible to display all sorts of merchandise, including foods, in their natural tempting colours, and textiles with all their shades and patterns, as well as to reproduce beautiful paintings for their attractive value. Perhaps as a result of this achievement in colour printing, there has been a remarkable improvement in the artistic worth of advertising illustrations. Celebrated painters and illustrators no

longer find it beneath their dignity to make pictures for advertising purposes, especially as the bids for their services run to large figures. Similar improvement has been achieved in typography, engraving and lithography, and in all the mechanical processes of reproduction.

As the volume of advertising expenditure has grown, so has the number of publications which derive their chief support from advertising. These publications have been divided more and more in recent years into groups or classes, each with an appeal to a certain class of the population. The number of general publications reaching all classes has been correspondingly reduced. The most prominent class publications are the women's magazines, chiefly of monthly issue, of which in 1921 there were four or five in America with more than a million circulation. These magazines deal with home problems, dressmaking, cooking, care of children and kindred subjects, and are the most valuable mediums for the advertising of foods, textiles and all household commodities. There are similar class publications devoted to business interests, the world of books, motion pictures, the theatre, fashionable society, sports of one kind and another and all classes of commercial and industrial enterprises. The significance of this tendency is that advertising of each kind may be placed before the readers it especially interests, with a selected audience and less waste of circulation.

Each succeeding year has seen some enlargement of the possibilities of advertising. Paid space has been used in increasingly large amounts in political campaigns, local and national, presenting the records of candidates and showing photographs of themselves and their families. It is used more and more to influence public opinion on behalf of one cause or another. Industrial disputes, involving strikes or lock-outs, have led employers and employees alike to appeal through advertisements to the public for sympathy and moral support. Public service institutions have used advertising to put themselves in a better light before the public or to explain the necessity for increased revenue. In one notable case, advertising was used to turn business away. The American Telephone & Telegraph Co. was seriously affected by the entry of the United States into the World War. It could not obtain the supplies it needed; the Government took thousands of its highly trained workers; and at the same time demands on its service increased enormously. The Company was wise enough to advertise, explaining why its service was deficient, why applicants were kept waiting for installations, and also imploring the public neither to conduct unnecessary conversations over the wires nor to prolong use beyond the time required. Similar advertising was employed by the American railways in the period immediately following their return from Government control to private management, but in this case the explanation of inadequate service was followed by an appeal for higher passenger and freight rates to provide revenue for rehabilitation. During the same period, the Chicago meat-packers, facing threatened Federal action for the further regulation of their activities, entered upon an elaborate advertising campaign to convince the public of their blamelessness.

All these varied developments of advertising have been of the utmost interest to students of economic trends. It is certain that advertising has been largely instrumental in changing buying habits and in introducing many things which have quickly become a part of everyday life. The chief function of advertising is the saving of time. Information, whether as to merchandise or controversial or public issues, can be placed before great numbers of the population almost over night. Public education on any subject can be effected in days or weeks, where years were required by old-fashioned methods of canvassing. For this reason it has been possible to build up entire new industries on advertised products within a short period. In political life, and in financial operations, advertising has served to eliminate the secrecy and ignorance which invite deceit and fraud. The whole tendency is to take the public into confidence and play the game in the full light of fair and frank publicity. Advertising is no weapon for dark causes and no advocate for unworthy goods. To be effective it must be a sincere expression of the character

of the advertiser. Unless it bears the stamp of truth and sincerity it is ineffective and defeats its own purpose.

This individuality of a business house as well as the conditions under which it operates and the field from which it may seek custom must all be considered carefully before embarking on an advertising campaign. It is well to seek the expert assistance of an advertising agency of established reputation. The implements of advertising are many, including newspapers, weeklies, magazines, trade publications, outdoor displays, cards in railway cars and the sending of circulars and booklets to persons whose names have been selected on some sound principle. Each is more efficient for one purpose than another, and knowledge and judgment are needed to plan a campaign that will achieve results at economical cost. The advertising policy of a business house and the selection of an advertising agency and advertising manager should be a concern for the executive heads who direct the permanent interests of the business. For advertising, once entered upon, is a continuing influence. The advertising for any one week or any one month, unlike that week's or month's buying or selling, cannot be regarded as a completed transaction. Advertising, it already has been said, is an expression of character. It reveals the character of the advertiser, and immediately begins to form a consciousness of the particular house or merchandise advertised in the mind of the public. It has an influence also on the advertiser's own organization. The workman in the factory and the salesman in the shop judge from the advertising their employer's sincerity and desire to serve. If the advertising is such that they can take pride in it; if it is attractive in appearance; if it is placed in the right environment; if it is a worthy representation of the purposes and ideals that animate the business—then the advertising will stimulate every employee to greater efforts and enhance the moral of the organization. Every advertisement tends to create or destroy the one great business asset, reputation.

The steady growth of advertising is assured. While there are no authentic data on the amount spent for advertising, it has been estimated that the expenditure for all forms of advertising in America in 1920 was upwards of \$1,200,000,000, an increase of approximately 100% in five years. Individual industrial firms in Great Britain spend as much as £200,000 a year on advertising, and the total expenditure there on all forms of publicity is estimated at over a hundred million sterling annually. With the growth in public intelligence and the realization of the power of advertising, it is likely to be still more widely employed in the future. The modern business concern is adopting advertising as a part of its fixed business policy; not as an expedient for occasional use but as an element of business to be constantly employed.

**AEHRENTHAL, ALOYS LEXA VON, COUNT** (1854-1912), Austro-Hungarian statesman (see 3.25; 9.951), was born at Gross-Skal, Bohemia, the son of Baron (Freiherr) Johann Lexa von Aehrenthal and his wife Marie, *née* Countess Thum-Hohenstein, and began his diplomatic career in 1877 as attaché to the Paris embassy under Count Beust. He went in 1878 in the same capacity to St. Petersburg, and from 1883 to 1888 he worked at the Foreign Office in Vienna under Kalnoky, with whom he formed close relations. In 1888 he was sent as councillor of embassy to St. Petersburg, where he exercised considerable influence with the ambassador, Count Wolkenstein. Recalled in 1894 to service in the Foreign Office, he undertook important duties, and in the following year went to Bucharest as ambassador. Here he succeeded in strengthening the relations between the courts of Vienna and Bucharest, the secret alliance which King Charles had concluded in 1883 with the Central European Powers being renewed on Sept. 30. In 1899 he became ambassador in St. Petersburg, where he remained until his appointment as Foreign Minister in Oct. 1906. Aehrenthal at this time thought that Austria-Hungary must, even at the cost of some sacrifice, come to an agreement with Russia. In this sense he endeavoured to continue the negotiations successfully begun by his predecessor, Prince Franz Liechtenstein (b. 1853), for the bridging over of the differences on Balkan questions

between Vienna and St. Petersburg, in order to create a basis for a permanent friendly relation between Austria-Hungary and Russia. He played a principal part in concluding the Mürzsteg Agreement of 1903. During the Russo-Japanese War he took a strong line in favour of a benevolent attitude on the part of the Vienna Cabinet towards Russia. When, in Oct. 1906, he succeeded Count Goluchowski as Foreign Minister he at first maintained the views which he had professed as ambassador. He was determined to preserve the interests of Austria-Hungary in the Balkans, but also showed himself prepared to meet the Russian wishes in the Dardanelles question. Accordingly he entered into negotiation, after the outbreak of the Young Turk revolution in the summer of 1908, with Isvolski, arranging with him Sept. 15 at the château of Buchlau, in Moravia, an agreement which aimed at securing for Austria-Hungary the annexation of Bosnia and Herzegovina and for Russia the opening of the Dardanelles to Russian warships.

It was only when Isvolski's proposals were wrecked on the opposition of England, and the Russian minister protested against the annexation of Bosnia and Herzegovina, which had meanwhile been accomplished, and supported the Serbs in their opposition to Austria-Hungary, that Aehrenthal abandoned the idea of a friendly accommodation with the Russian Government. In the sharp struggle during the annexation crisis, not only with Russia and Serbia, but with the Western Powers, he held with tenacious energy to his purpose, and, powerfully supported by Germany, succeeded in carrying out his intentions after excited negotiations which threatened to lead to war. The annexation of Bosnia and Herzegovina was acknowledged by the Powers; an agreement was reached with Turkey; Serbia, after long hesitation, was obliged to submit. For this achievement Aehrenthal was rewarded by his master by elevation to the rank of Count (Aug. 18 1909), while at the courts of his opponents he was hated but respected.

This was the zenith of his political career. Few at this time realized the danger which arose later from the closer adhesion of Russia to the Western Powers, especially as Aehrenthal took the greatest pains to prove in all quarters, after the conclusion of the annexation crisis, that Austria-Hungary cherished no far-reaching plans of conquest. In this spirit he offered the most decided opposition to those circles at the court of Vienna which advocated a bloody reckoning with Serbia. He held fast by the Triple Alliance, for he saw in this the surest bulwark of peace. He sought to form the most intimate relations with the German Empire, but insisted on the independence of the Habsburg Monarchy, and energetically repulsed all efforts on the part of the German chancery to set limits to that independence. One of his most difficult tasks was to adjust the ever-recurring conflicts with Italy, who, while officially supporting the political action of the Triple Alliance, often embarked on courses directly opposed to the interests of Austria-Hungary. A succession of agreements which he concluded with the Italian Foreign Minister, Tittoni, justified his efforts, and enabled him to maintain correct relations with the Italian Government. Yet, by the maintenance of his peace policy, which had the full approval of the Emperor Francis Joseph, he came into serious conflict with the party led by the chief of the general staff, Conrad von Hötzendorf, which championed a policy not afraid of energetic, warlike methods. The battle, carried on on both sides with tenacious endurance, ended in 1911 with the victory of Aehrenthal and the resignation of Hötzendorf.

In the solution of questions of internal policy Aehrenthal, as Foreign Minister, only took part in so far as they seemed to him to affect the interests of the monarchy as a whole. With the Czechs, who on his accession to office had shown some suspicion on account of his intimate connexion with the leading members of the loyal Bohemian landed aristocracy, he succeeded in maintaining reasonably good relations. As against the Magyars, he upheld the view that the unity of the monarchy must not be shaken, and he therefore offered a determined resistance to the attempts of the party of independence to intrench on the rights of the Crown in military matters. He realized the need for an

increase of the army and the reorganization of the army and navy, but he opposed the far-reaching demands of the War Minister and the chief of the general staff.

Aehrenthal married in 1902 Pauline, Countess Széchenyi. He died Feb. 17 1912.

Even during his lifetime the estimate of his political policy fluctuated violently. On the one hand it was blamed as provocative, on the other as weak. After the disastrous result of the World War, bringing with it the downfall of the Habsburg Monarchy, it is still more difficult to answer the question whether the path pursued by Aehrenthal in foreign affairs was the right one. It is certain that the Entente Powers were drawn more closely together by the active part played, during his period of office, by Austria-Hungary in Balkan affairs. It is true that the chances of success for the Central Powers in an international struggle were better in the years 1909 and 1911 than in 1914. But the question remains undecided whether, if his activity had been longer continued, Aehrenthal would have been able to maintain the position of Austria-Hungary as a great power without an appeal to the decision of arms. There is no doubt that Aehrenthal was a statesman of considerable mark, a man of wide knowledge and well-ordered intelligence; he was ambitious, but not vain, and an untiring worker. Moreover, in moments of great excitement he was able to maintain outward calmness. He was convinced of his own value, but had no desire to parade it. The Emperor Francis Joseph esteemed him, stood by him in the good and evil hours of his administration of foreign affairs, and repeatedly refused to accept his tendered resignation.

See B. Molden, *Alois, Graf Aehrenthal: Sechs Jahre ausserordentlicher Politik Oesterreich-Ungarns* (1917); and the article "Aehrenthal" in the *Deutsche Neurologen* (vol. xviii., 1917, pp. 230 seq.).  
(A. F. PR.)

**AERONAUTICS** (see 1.260).—Between 1909 and 1921, Aeronautics, an infant to start with, had not grown as a child grows, but irregularly. One member had prospered at one time and one at another. Thus we find that enterprize in flight was early in advance of all appliances; then engines developed for a period; later, structural design. Though aerodynamic theory had been far ahead it was badly neglected for a spell and was once again fostered; with this study secret and semi-magical wing shapes disappeared; after that came methodical production, first in units and subsequently in bulk; then came pilotage and the elements of commercial flying. The seaplane, though less risky than the aeroplane, advanced even more fitfully and never caught it up; the airship, which was earlier and safer, still lagged behind because it made less appeal to sensation and cost much more. The engine, though once in advance, fell behind, and only now (1921) is again full of promise. Landing-grounds and night alighting facilities have advanced but little, meteorology progresses slowly against fog, the enemy, but aerial navigation is at last appearing as a science.

By taking such of these elements as have separate stories and keeping them distinct in the several sections which follow, it is hoped to present more clearly the progress and prospects of aerial science than by showing a series of moving pictures of the infant prodigy in motion as a whole.

*Achievements and Performance* (see Section I.).—The twelve years of labour of the American Wrights culminated just before 1909 in the birth of the art as we now know it. Hazardous flights on the straight or in figures of eight; a circle over Paris; the crossing of 24 miles of sea; the excelling of the speed of an express train, a velocity once deemed monstrous and now insignificant; the scaling of the Alps; looping and inverted flying; leaving the craft by parachute; releasing the first 1,000-lb. weight; firing the first gun; discovering how to get out of a spin; alighting by night, etc.—each of these was an experience and a token of growth. Each seemed perilous and astonishing, yet they had become so common by 1921 that it was already difficult even to remember the sense of wonder.

*Design* (see Section II.).—The advance of design occurred away from the public vision, nor were its milestones of progress coincident with the landmarks made by the great performers who relied more on their own tact in the air than on the tested and thought-out qualities of their craft. They chafed under the cautions of those who made stress calculations. Each "stunt" was performed before any human being knew if it was safe. How and why was design altered



and bettered under the circumstances? Yet strength factors were introduced, down pressures foreseen, fine lines provided, wing shapes and controls improved, alighting gear developed and instability cured. This is the subject matter of Section II, which is closely allied to Section III.

**Aerodynamics** (see Section III).—Aerodynamic theory had risen out of the void at the bidding of the applied mathematician before 1909, but it developed at the call of designers who would have been tied to the repetition of old methods had not theory justified departure. Once aerodynamic theory was established their inspiration could take wing.

The deductions<sup>1</sup> from wind tunnel experiments on models 2 ft. long could be but surmises till the principle of dynamic "similarity" emboldened designers to transfer the wind tunnel results to the 40-ft. machines. "Scale effect," "slipstream effect," pressure distribution, phugoids, and the like, had to be verified on the full-sized aeroplane and measured in the course of flight with the coöperation of a few keen fliers, at a time when pilots at large were almost antagonistic to "theory." Mathematics had been applied to the motion of aeroplanes through the air in advance of even the earliest flight, and several separate starts were made. England, represented by F. W. Lanchester, was easily first. Lanchester made great strides, at a time when he had no wind channel for his model verifications. Bryan came independently; L. Bairdow had the wind tunnel, of which he has indicated the arrangement in Section VI, and greatly advanced the problems. It was E. T. Busk who in 1913 in his own person as flier verified the theories he had formed and achieved stable flight on "RE I" (see Plate I, fig. 1). America had led in initiating practical flight; France in model experiments, rotary engines and speed records; Germany in length of aeroplane flight and in rigid airships; but in the matter of stability and of scientific analysis on both model and full scale, Britain took the lead before the war and still kept it in 1921. Something of each national temperament is disclosed by these specializations.

**Construction and Materials** (see Section IV).—Aircraft constructional methods are to be regarded from two points of view—the one where a few craft are to be made as perfect as possible, and the other where bulk production is demanded.

Before 1914 there was no output of aircraft in Britain other than by units; in France there was some manufacturing, in America a little, and in Germany rather more. These countries had factories proper where repetitive processes were employed. An army, small in numbers, was deemed in Britain to need correspondingly few aircraft. A large navy neglected them. When bulk production came it came with a will, but designs that were admirable for unitary construction were found ill adapted to bulk manufacture, and the British story of changes in material and methods which is outlined in Section IV, is typical of the war period everywhere.

The tautening of fabrics with cellulose acetate, the evolution of the fairshaped strut and wire, the steerable tail skid, sewing the fabric to the wing ribs, covering the wheel spoke with fabric, were among the step-by-step advances which all belong to the period before large outputs were contemplated, i.e. the period when, for example, joints were machined from the solid steel bar. The plywood body, the spars of built-up wood, the standard relation of radiator to engine size, the pressed metal turnbuckle and the thorough interchangeability of detail parts belong to the "bulk output" period, as also incidentally much speeding-up of processes and methods, the evolving of glues and cements, fine castings, new alloys and the widespread use of tests not hitherto commercialized but known to be good by the few. It would be truer to say that the World War disseminated the science of aeronautics rather than that it fostered it. The war did foster the technics of quantity production.

**Aero Engines** (see Section V).—Man would have flown long before he did but for the lack of a light engine. One cwt. per horse-power was about the weight of the commercial gas engine, and to fly he wanted one twenty times lighter. The French rotary engine of 1909-10 was the most real promoter of aerial experience of its time, for it weighed 4 lb. where a motor-car engine weighed ten. How and by what grouping of parts, increases of compression and refinements of design, this weight has been cut down to 2 lb. with fuel economy on a similar scale, appears in Section V. Here it will only be noted that the Germans on the basis of airship experience had inclined rather earlier than others to big powers on aeroplanes, and their aeroplane successes on aerodynamically inferior craft were due to big engines. Their engines were water-cooled, rather heavy but reliable. The radial air-cooled engine of the French has been mentioned above. The British service was late to realize how very big the war aero engine must be, and developed an air-cooled, non-rotary and some good water-cooled motors eventually of adequate sizes. The Americans made good use of the experience poured in upon them from Europe when they began in 1917 to tackle the Liberty engine of 450 H.P. Apart from size, the advances in view to-day are considerable. The means for protecting ourselves from the fire risks on crash due to petrol are also being evolved.

**Navigation** (see Section VI).—Aerial navigation, as distinct from piloting with the ground in view, developed tardily everywhere, though first in Britain. It was a surprise to find that raiding airships

from Germany disclosed no up-to-date navigating apparatus when they were brought down, nor had their aeroplanes any turn indicator to guide them when immersed in cloud or fog. Even after seeing the Lucas compass (see Plate I, fig. 2) on captured aeroplanes they did not appreciate or copy it, nor its principle of the "space-damped" vertical card, spherical bowl and long period; nor was there anywhere an instrument to compare with the British apparatus figured in Section VI. The air speed indicator that uses the principle of Pitot was also a British idea, which displaced the earlier French flat plate speed back by the wind against a spring, and other such speed-meters.

**Control of Air Traffic and Air Stations.**—Air stations and the rules evolved to control traffic have a section (VII.) to themselves. The early stations were fields and each flier a law to himself. When the Air Convention of Oct. 1919 is ratified all aircraft will be taboo that have not a specific factor of strength and an adequate field of view for the flier. As we progress all stations will give wireless warning to those approaching them when they are immersed in fog and will afford facilities for night alighting. The movement is in this direction. The mobility of aircraft makes international agreement on all rules for alighting, racing, and signalling, warnings very important. Bodies like the Royal Aero Club in Britain exist in each country and meet annually for these purposes.

**Seaplanes** (see Section VIII).—The seagoing seaplane is relatively backward. To make a craft light enough to fly and heavy enough to stand the buffets of the open sea up to the speed needed to quit the waves in flight is a problem which was not fully solved even under the war stimulus. It was tackled too late—by Britain no less than the others. Even the high-speed "float" seaplane was neglected in England but it eventually advanced in Germany to be a formidable offence against the air enemies of the submarine. Theirs was not, however, a craft that could ride out a sea. The American NC3 made a record by riding on the water for 150 miles in its Atlantic crossing. It was an achievement to withstand the sea so long even though the craft was travelling backwards all the 150 miles. Section VIII shows that scientific work is being applied to the problem, notably in the matter of stability when changing from waterborne to airborne conditions.

**Airships** (see Section IX).—Airship knowledge gave to Germany technical advantages which would have been even more valuable to Britain. They did not use on aeroplanes the identical engines of their airships, but the experience of large aero engines of the utmost reliability and economy was there. The dominant advantages of airships are that they fly for long hours, carry large weights, do not descend for an engine failure and can safely fly by night. In consequence of night flying they are able on long journeys to outstrip the aeroplane in speed from point to point. High cost of housing and the numbers required to handle them on the ground were their chief hampering factors, but the wonderful development of the mooring mast, a British device, has improved the position. The towing of airship by airship and by submarine, the protection of fabric from deterioration, the use of non-inflammable gas are all landmarks in their evolution. The kite balloon and the parachute also need mention, though opinions differ as to the advisability of giving the latter to the commercial aeroplane as a life-belt is given to the liner. It is of little use unless the jump is made over 200 ft. from the ground; if a high wind is blowing the parachutist meets the ground with the sideways speed of the wind and it absorbs 18% of the useful (passenger) load. This position is, however, the result of great advances which have assuredly not ceased.

Each sectional aspect of aeronautics between 1909 and 1921 divides itself into three periods: before, during and after the war. The dominant emotions and aspirations of those periods governed men's thoughts whether they were flying, designing, calculating; experimenting with engines, model aeroplanes or safety devices; evolving navigational instruments, tests for pilots against giddiness, or parachutes to save the lookouts on kite balloons. Before the war the aircraft builder starved although it was early accepted that frontiers, rivers, chasms, forests and entrenched positions could be crossed by anyone brave enough to fly, but that acceptance was half-hearted. It now amazes one to realize that in 1911 the speed of flight was regarded as a defect for the military aeroplane, or that vulnerability by gun-fire from the ground was its supposed weakness. The Governments demanded that their aeroplanes should be transported in crates, or towed with folded wings to their jumping-off place (see Plate I, fig. 3). An aeroplane was a mute observer; no means of continuously transmitting observations—say of artillery fire or enemy movements—or for making photographic records had been tried out, accepted as good or prepared in quantity. Imagination is greater than fact when the imagination is active: all these effects could easily be, and were, imagined once flight was admitted—but the state is a herd, and extends its imaginative power like a herd to the distance of the next meal or next year's crop. All nations econo-

<sup>1</sup> See "Flight," 1912, pp. 32, 33.

mized in aircraft research. Only individuals in any army, navy or populace appreciated it. Its exponents were a butt for attack.

Still it was war or the fear of war that was responsible for what there was. War has often been the great inciter of technical advances—it accounted for the Roman roads and for the modern steel industry when battleship plates were founded and forged. Such industries have in the past made some compensation to the world for their malignant first inspiration. So, too, will aircraft in its civilian uses and in many indirect ways.

The exact calculation of stresses, the exact adaptation of material to meet them, the most radical economy of avoidable weight, all of which are in the essence of engineering progress, have been enforced upon the new engineer physicist of aerial science, and young and brilliant aircraft engineers have, since the Armistice, been thrown into industry generally, imbued with the exactitude and thrift of mechanical material learnt under the grave penalty attaching to small errors in strength, weight or quality or design for aircraft construction.

The introduction of the scientific idea was an intense uphill struggle. Flying was first in the hands of men of enthusiasm rather than of precision, the pioneers were more courageous than scientific or critical. Dynamic similarity, the theorem of three moments and the like were uninteresting to the small makers, and all makers were in a small way. The data for the calculation of aeroplane stresses were insufficient to move the larger firms to quit the imitative methods of design which were the beginnings of the industry. The risks from obvious misadventures, from fliers' errors, from bad landing-grounds, etc., were so great that the hazards to be guarded against by calculations and wind-tunnel experiments appeared few and negligible by comparison.

Before the war public pressure had a rather doubtful directing influence. If it was not explicitly said that such appliances *must* be frail and dangerous, it was assumed. In one country after another the ministers were rather upbraided by the air industry and dismissed eventually for failing to spread themselves on large orders than urged to develop the basis for strength and balance, by expenditure now proved justifiable on precise calculations, laboratory work and mathematics, finer metallurgy, woodcraft and chemistry, instruments and navigation such as are recorded in the succeeding sections.

The main efforts made on the scientific side have been individual, and for those individuals are mainly unrequited. Many are dead—scarcely heard of—E. T. Busk; K. Lucas; R. M. Groves; B. Hopkinson; Pilgrim; Pinsent; Usborne; many others lived on in 1921 to see the result of their work, which was unparalleled in brilliance of achievement. Fortunately the names of the performers of heroic flights live on, and many—unavoidably there are omissions from so great a list—appear in Section I.

In 1911—the compelling necessity for providing in the interests of fliers a margin of strength for aircraft, calculated upon the stresses induced by its speed and by its manoeuvres, was first accepted. So far as we know, this importation of an engineering standard was British, and was imposed upon foreign suppliers for the first time.

The various nations, each wanting to know how the other was getting on, would purchase a few examples abroad; a proceeding naturally coupled with any known precautions for the home flier whose person would be risked in testing them. In any country the industrialists regarded foreign purchases with some jealousy, since a tenuous air vote was seen to be expended elsewhere than with the home constructor; still an informative exchange of technical knowledge ensued.

The 20 H.P. engine of Wright and the 35 H.P. engine of Green were seen to be too small by any who knew the 50 H.P. Gnome in flight. The speedy monoplane of Nieuport (French 1910) showed Britain the value of smooth external lines for the craft. The Wright biplane (U.S.A.) bore only 2 lb. per sq. ft. of wing area, and Farman followed its lead in France. The uses of heavy loading, as in the De Havilland craft, appeared later, when its demerits were envisaged and difficulties, such as the high speed of alighting, overcome simply by the great skill and courage of fliers. The German Zeppelin taught much to Britain. The

British Avro and BEAs taught the possibility of a wide speed range to the French and others, and generally aircraft lore became international. (M. O'G.)

### I. PERFORMANCE OF AEROPLANES, 1909-1920

*The Arena of Aeronautics in 1909.*—The achievements in 1909 had been latent in the effort of the previous 40 years; that which appeared sudden was the outcome of protracted experiment and the driving force of great personalities. The date recalls the names of Wright; Voisin and Farman. The year 1908 had made power-driven flight a reality. Farman had flown from Châlons to Reims; Orville Wright had flown for over an hour in America; Wilbur Wright held the Michelin Cup with a flight of 224 km. in France.

In 1909 men little knew at what bitter cost he would maintain the conquest of the air; yet the toll of life served but as a stimulus. The International Conference that was held in London consolidated the position of the Aero Clubs of the various countries with a view to the advancement of aeronautics as an organized movement. The great natural flying-ground at Pau soon made it the Mecca of aeronautics. There Wilbur Wright created the first flying-school, and among his pupils were names now famous. At the aero show in London the public inspected and handled machines that really flew. At Farborough, Cody was experimenting with a machine that was to glide down a wire. Blériot, who had emerged from crash after crash unscathed, flew from Étampes to Orleans, 25 miles. His little machine hopped over hedges and trees, its diminutive engine humming above the roar of the Paris-Orleans express, the windows of which were white with faces upturned to see the new wonder. On a memorable Sunday morning (July 25 1909), Blériot set out from France without a watch or compass to fly the Channel; his monoplane was lost in the haze; but he emerged triumphant towards the cliffs of Dover, where he landed on a slope and crashed. His feat eclipses all others of the year, and is the forerunner of the crossing of the Atlantic 10 years later. The analogy goes further, for Hawker's failure to cross the Atlantic is reminiscent of that other failure of Latham's to wrest the prize from Blériot.

The year is memorable for flying meetings which roused public enthusiasm in many countries: at Reims, Brescia, Berlin, Cologne, Blackpool and Doncaster. At Reims Latham covered 96 m., while later in the year Paulhan climbed to 600 metres, a dizzy height in those days. The Comte de Lambert, a pupil of Wright, flew from Juvisy round the Eiffel Tower and back, the first flight over a town. In Germany Herr Grade won a £2,000 prize for the first German to fly a figure of eight round two posts placed 1 km. apart. At the close of the year Farman held the Michelin Cup with a fine flight of 234 km., made at Châlons.

*The Flying Qualities of the Early Aeroplanes.*—So rapid has been their development that it is worth recalling what these early aeroplanes were like. The factors which govern the balance of an aeroplane and the respective functions of the movable and fixed surfaces used for its control during flight were, in 1909, ill understood. The probable, possible and impossible were all one. Aeroplanes were built by eye and developed by trial and error; the light aero engine was in its infancy. Wilbur Wright laid the foundation of aeroplane control as we now conceive it, but hampered it by combining the movement of the vertical rudder with the warping of the main planes for turning in the air. The pioneers flew almost by blind instinct; they had but the vaguest idea of how to remedy a loss of control; some were even inclined to doubt that remedies existed; atmospheric disturbances and so-called "air pockets" were referred to with awe; instruments which now assist the maintenance of balance, attitude and flying speed were unknown, and when suggested were objected to; it was all that human concentration could do to make proper use of the control surfaces to maintain equilibrium, not only because the equilibrium was essentially of an unstable kind, but because the control surfaces themselves were often incorrectly designed and thus treacherous or inadequate. It was on such machines that the early pioneers committed themselves to the air, breaking records over land and sea.

*The Pre-War Years.*—The chief flight of the year 1910 was Faulhan's from London to Manchester, by which he won the *Daily Mail* £10,000 prize (April 27 and 28 1910). The race was gallantly contested by Grahame-White. If skill and tenacity had been the determining factor, the prize would have been hard to award. The chances of the race aroused the greatest enthusiasm and to the many incredulous one more demonstration was thus given of the possibilities of the aeroplane.

During the year flying meetings were held at Heliopolis, Wolverhampton, Bournemouth, Blackpool and Lanark, the flying performances at which demonstrated the advance that had been made on those of the previous year. At Bournemouth England lost one of her best fliers, the Hon. C. S. Rolls, who had previously made the double journey across the English Channel. His statue stands at Dover, gazing out over the waters that he crossed. Most British pilots were flying on aeroplanes that were wholly or partly French, but it is to be noted that Moore Brabazon won the British Michelin Cup with a flight of 19 m. on an all-British machine. At Lanark Chavez on a Blériot monoplane reached a height of 1,794 metres, a prelude to his magnificent flight over the Alps, the tragic sequel to which was his fatal accident on landing. Legagneux, however, created a record by reaching a height of 3,100 metres.

Moisant flew from Paris to London but, though he quickly reached English soil, various troubles delayed his arrival in London till three weeks later. On the continent, Leblanc won the £4,000 prize for the *Circuit de L'Est*. Grahame-White went to America and brought back the Gordon Bennett Cup, which Curtis had won the year before. The contests for the British Michelin Cup and the Baron de Forest prize brought forward new fliers. Sopwith, competing for the former, flew 100 m. at Brooklands, which had been opened as a flying-ground the year before, thus beating Cody's distance of 97 m. which had previously stood; competing for the latter he flew from Eastchurch well into Belgium.

At the close of the year Cody, after an exciting contest with Sopwith and Ogilvie, held the British Michelin Cup with a distance of 185 m. in 4 hours 47 minutes. In France Tabuteau held the International Michelin Cup with a distance of 582 km. in 7 hours 48 minutes.

It was in 1911 that the aeroplane was first tried in warfare. Hamilton, an American, carried out a flight over the town of Ciudad Juarez during a Mexican rebellion. In their campaign in Tripoli the Italians also realized the value of the aeroplane for reconnaissance. In England the idea of the time was that, for bombing, aircraft would be useless and contrary to international usage; on the other hand, the first British attempt was made to run an aerial post between Hendon and Windsor.

Capt. Bellenger, a Frenchman, flew from Paris to Bordeaux in 5 hours 10 minutes net time, a distance of 690 km., while later Fourny remained in the air for 11 consecutive hours, covering a distance of 720 kilometres. Garros made a height record of 3,920 metres. London was linked with Paris by a notable non-stop flight by Prier, which foreshadowed the aerial services of to-day.

The year 1911 saw many races: the Paris-Madrid race won by Védrières at 50 m.p.h., in the course of which the French Minister of War met his death and the premier was seriously injured; the European Circuit, divided into nine stages, with the recently opened Hendon flying-ground at the end of the seventh, which was won by Lt. Conneau flying under the name of "Beaumont"; the *Daily Mail* race round Great Britain of 1,010 m., also won by "Beaumont" with Védrières as a close second.

The Gordon Bennett Cup was won for America at Eastchurch by Weyman flying a Nieuport monoplane at 90 m.p.h., and the International Michelin Cup for France at Gidy-Lumery by Helen with a distance of 1,252 km. in 14 hours 7 minutes at 56 m. per hour.

The increase in performance over the previous year may be referred chiefly to the development of the aero engine. It would be difficult to say that fliers were more skilful, but it is certain that they were able to substitute knowledge and experience for

pure instinct, and thus set out on long and arduous flights with increased confidence in their own powers and in the reliability of the aircraft they flew.

One of the most prominent features of the year 1912 was the active part that the British and French Governments took in the development of aircraft for war. The French Minister of War held a great review of military fliers and aeroplanes, and British aircraft took a conspicuous part in naval and military manoeuvres. The Cody pusher biplane won the £4,000 prize in the War Office trials on Salisbury Plain in the summer, during which the tractor biplane BE2 reached a height of 9,500 feet. In Sept. four army fliers lost their lives in two accidents in monoplanes, which led to close restrictions being placed on their method of bracing in England. In March the French Government had imposed a ban on certain monoplanes until the defects were removed as the result of a report by Blériot on their structural weakness.

Garros won the *Grand Prix* of the Aero Club de France for the Anjou Circuit of 685 m. at 45 m.p.h.; Sopwith the first Aerial Derby at 59 m.p.h., a race round London of 81 m.; Védrières the Gordon Bennett Cup in America at 105 m.p.h.; Audemars flew from Paris to Berlin; and the two British Michelin Cups were won by Hawker and Cody, the first with a duration of 8 hours 23 minutes, and the second with a flight over a circuit of 186 m. in 3 hours 23 minutes; in France Daucourt for the Pommery Cup flew 550 m. in a single day at 63 m.p.h., while at the meeting at Leipzig Hirth reached a height of 4,100 metres. World's records were made in height by Garros, who reached 5,610 metres; in distance by Fourny with 1,010 km.; and in speed by Védrières with 174 km. per hour, over 5 kilometres.

In the spring, flying had suffered an irreparable loss in the death of Wilbur Wright from typhoid fever.

Apart from the establishment of the fundamental merit of the tractor biplane the year was notable rather for a steady improvement in strength and detail than for any radical departure in type. From this time it becomes increasingly difficult to single out individual performances. Achievements deemed impossible three years before became commonplace events.

The year 1913 was one of great progress. Long cross-country flights were proving day by day the faith that fliers had in the aero engine. Seguin in France covered 1,021 km., Legagneux reached a height of 6,120 metres, while Prévost attained the speed of 203 km. per hour, over 5 kilometres. It was a brilliant year for him; he won the Schneider Cup for seaplanes at Monaco, covering 150 nautical m. in 3 hours 48 minutes, and the Gordon Bennett Cup at Reims at 124 m.p.h. Helen won the International Michelin Cup with a distance of 16,096 km. Captain Longcroft won the Britannia Challenge Trophy by a magnificent flight from Montrose to Farnborough via Portsmouth on a BE2 aeroplane built by the Royal Aircraft factory. Hamel won the second Aerial Derby at 76 m.p.h., while Pégoud in France and England gave some of the most marvellous demonstrations in the new art of aerobatics that the world had ever seen, including looping, inverted flying and quitting his aeroplane in a parachute. In Dec. 1913 the RE1, the first aeroplane stable longitudinally and laterally, was flown for 35 minutes without hand or foot control; and this, which may be regarded as the greatest technical advance in aerodynamics, is to the credit of Busk, an Englishman, who both made the flight and applied the theory on which the aeroplane was designed. The last previous attempt of the kind was by Dunne, who a few months earlier had flown for one minute with "hands off."

The year 1914, just as it marked a turning point in the affairs of nations, altered the whole character of flying. For seven months the ideas of safe, stable flying and safe alighting were dominant; then the World War came down like a curtain and blotted them out in favour of widely different objects. During those months, Sykorsky, in Russia, had been proving the weight-carrying possibilities of the aeroplane, and had risen to 300 metres, carrying 15 passengers. At Farnborough, an SE4 (see Plate I., fig. 4) flew at 130 m.p.h. and climbed 1,400 ft. in a minute. Linnekogel had reached a height of 6,350 metres in Germany, though just before the war Oelrich beat him by reaching 7,860 metres. Landmann

in Germany remained in the air for 27 hours 48 minutes, while Boehm further improved on this unofficially with a time of just over 24 hours.

The Schneider Cup for seaplanes was won for England by Pixton, who covered 150 nautical m. in two hours at Monaco on a Sopwith biplane fitted with floats. The Aerial Derby, the London-Manchester-London and London-Paris-London races were all won by Brock. Notable events on the Continent were the Prince Henry Circuit of 1,125 m. in Germany, in which there were 40 competitors, and the Security competition in France; although most of the big international races had to be cancelled.

*The World War.*—The ingenuity that sought for speed at low heights suitable to the race-course or for the maximum climb was by no one appreciated as vital for war purposes, either in France or Germany, and least of all in Britain; aeroplanes were for reconnaissance—they should fly slowly—and the very inferior anti-aircraft guns would not impede their flying low; it was not till many months elapsed that the margin of speed and climb was found to be decisive as to who should be the victor in mortal combat held in the upper air. The diverse needs of war stimulated the development of specialized types, which were evolved as fast as production considerations would admit. The prime use remained, as foreseen, reconnaissance, but to maintain and support this other craft were called into being; the possibilities of the aeroplane as a bomb-dropper were as yet hardly called for. The early war pilot went into battle armed more as a sportsman than as a soldier. But he was attacked, and had either to be made self-defensive or to be escorted by fast, high-powered, swift-climbing fighters.

In 1915 the artillery on the ground came to rely almost entirely on aerial "spotting," and the small single-seater fighters had to sweep hostile aircraft from the skies to allow such machines fitted with wireless to pursue their work uninterrupted. Bombing was also rapidly developed. The first time a 1,000-lb. weight was released by Goodden from an aeroplane was an event calling for a special communication to the Secretary of State that by big bombs the nerves and arteries of the enemy might be continually harassed and disorganized. Owing to freedom of movement in three dimensions air supremacy was a far more difficult and comprehensive thing than naval supremacy. It was never achieved save locally and for brief periods by any Power, and then only by concentrating organizations of the greatest mobility and flexibility at some place and time.

The requirements of quantity, coupled with the demands for change, came so rapidly that the development and expansion of the aerial arms of the Great Powers are difficult to grasp. Of the innumerable acts of courage, the endurance and self-sacrifice, the skill of the pilot in war, it is impossible here to attempt a record. Here and there the names of great pilots stand out. But if one be mentioned, a hundred others would claim justice. Such were the changing fortunes of war, so many and so astounding were the feats of daring, that with deeds not unworthy of a Ball, a McCudden, a Bishop, a Nungesser, a Garros, a Guynemer, a Védriers, an Immelmann, a Richthofen, a Boelcke or a Voss, many a fier passed through the war without fame or praise.

It was only during 1915 that the specialized type of aeroplane began to appear. The two-seater aeroplane with an engine of up to 150 H.P. was used promiscuously; for reconnaissance, artillery "spotting," any bombing there was, and fighting as well. Types in use by the British were BE2C's, Avros and Blériots, with small engines below 100 H.P.; by the French, Caudrons, Breguets, Farman's, Voisins, Blériots and Moranes; by the Germans, LVG's and Rumplers, with engines over 120 H.P. and up to 160 H.P.; the maximum speeds seldom exceeded 80 m. per hour. Later in the year the single-seater, originally intended as a scout, was used for fighting. The 80 H.P. Bristol scout and other tractors used by the British were handicapped by their inability to fire forwards, the direction of best aim; the various models of Nieuport and Morane scouts used by the French were also adopted by the British, while the Albatross and Fokker scouts were used by the Germans. Engines up to 200 H.P. were coming in. The so-called "scout" became a real fighter; its speed and

climb became truly effective when firing through the propeller was devised by a Frenchman, adopted by Germany, and then with feverish haste by the Allies. The French and Germans, more zealous about bombing, were for this purpose introducing large twin-engined aeroplanes and experimenting with armoured ones. Speeds rose to over 100 m.p.h., and aeroplanes flew and fought at heights of 15,000 ft., whither they were driven by the increasing intensity of the anti-aircraft fire and by the advantage to be derived from a swift descent to pounce or to retract. Night flying, which had been tentatively practised for exhibition before the war, was taken seriously, as its potentialities for bombing, for the depositing of spies and for other conveyance were realized. Stable aeroplanes with special alighting gear and a clear forward field of view were needed for the repelling of airships by night. The loading of war aeroplanes was increased and was only limited by the absolute necessity of reasonable landing speeds; even then fast scouts taxed the skill of most pilots. Seaplanes, whose aerial performance was always poor compared with that of aeroplanes, were of great use in conjunction with naval operations, and took part in the Gallipoli campaign.

In 1916 the air services came more and more into prominence. The cry for higher and yet higher performance was insistent. The French Spad flew at 130 m.p.h. and reached over 20,000 feet. The German Albatross scouts manoeuvred magnificently at great heights, and high-flying reconnaissance. Rumplers with cameras photographed back areas. Bombing flights up to 800 m. were carried out, notably by the French. Night bombing and even night reconnaissance became general, first on moonlight, and then, as the flier's skill increased, on dark nights. Accessories for night flying, such as wing tip flares, were developed. Airships had already proved vulnerable to aeroplane attack, and a German airship was brought down in flames at Cuffley on Sept. 3 1916 while engaged in raiding England by night. Kite balloons were attacked and brought down with incendiary rockets and bullets. Flying became organized, and aeroplanes patrolled in larger and larger formations and in layers, each unit being allotted its respective duties, signals being made by coloured lights. Slower aeroplanes were escorted by fast fighters; other fighters, like hawks, moved on mobile offensive patrols.

As peace seemed no nearer in 1917, redoubled efforts were made in the air. America joined in, and American fliers joined British squadrons, finally forming their own; the Italians had developed large twin-engined Caproni triplanes; the Austrians, the Turks, all realized what air-power meant. The British used large twin-engined flying-boats against the submarine. The Germans eventually attacked with big float-seaplanes of remarkable speed. Scouts were flown off lighters at sea against airships, and off the decks of battleships and "mother" ships. Formation flying was developed and aerial fighting of the fiercest intensity was the prelude to every big land operation. The British SE5A's and Sopwiths, the French Nieuports and Spads, the German Albatrosses, Rolands and Fokkers, swept the sky in "circuses" 30 strong, and the effect of superiority of performance was hard to distinguish from sheer skill in handling.

As the last and bitterest struggles of the World War were being waged in 1918, aerial activity reached its zenith. The deep hum of aircraft practically never ceased by night or day, in fair weather or foul. Large twin-engined Handley Pages and German Gothas flew farther and farther afield on bomb raids; retreating armies in the East fled before the onrush of death from the air. Aeroplanes flew low and attacked anything they could find on the ground. Large flying-boats patrolled vast expanses of water. The night was full of the attackers and the attacked, for fighting scouts had learnt to seek out and fight the night bomber. Engines had become more and more powerful and had reached 400 horse-power. The height at which an aeroplane could fly was limited rather by the physical endurance of the pilot, even with the help of oxygen, than the possible "ceiling" of the aeroplane. It would hardly be an exaggeration to say of the aeroplanes used in the first and last phases of the World War that their relative effectiveness as fighting implements was commensurate with that of a bow and arrow and a modern rifle.

*The Art of Flying in War.*—If, in war, higher performance was the prime means of gaining the position to strike, controllability was essential to direct the blow. Pégoud had given a glimpse of the possibilities of aerobatics in 1913, and during the war these possibilities were explored to the uttermost. Probably owing to temperament, the French led the way. The pilot of a fighting aeroplane simply came to regard his machine as a mobile gun platform, whose motion must be in sympathy with his lightest touch to enable him to get his sights on the target. In fighting-scouts the guns were integral with the aeroplane, the nose of which was controlled so as to point them at the target. With opposing machines of equal performance the striking position had to be gained by manoeuvre, confidence in which was inspired by a good view of the opponent. In order to use his guns effectively, the pilot's arcs of view had therefore to be made as large as possible. Though "looping" itself was little used, half-loops and "Immelmann" turns enabled the pilot to turn rapidly while gaining height.

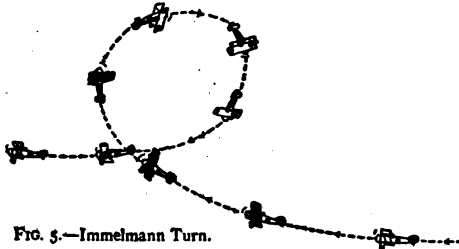

FIG. 5.—Immelmann Turn.

Until 1916 spinning nose-dives had merely been associated with loss of flying speed and control, almost always with fatal results. A courageous demonstration of the method of recovery from a spin by Goodden, and later the practical application of the theory by Lindemann, both at the Royal Aircraft factory, did much to prevent future accidents. A spin came to be regarded, not with fear, but as a means, if crippled, of eluding attack.

French pilots again pointed the way in the art of "rolling," a manoeuvre in which the aeroplane is rolled about its longitudinal axis. In 1917 this manoeuvre was widely practised. The development of an aerial combat was so swift that the first few seconds might decide the fate of one of the opponents. It was rather in a brilliant combination of the manoeuvres described above, calculated to make effective striking possible while presenting an elusive target, than in the use of any single manoeuvre, that the war pilot put his trust. He had to study the characteristics of the aeroplane he was attacking, single or two-seater or large bomber, gauge its weakness, divine the mentality of its pilot and pit his skill against it; but it was grit and the will to close and finish it that alone could be the decisive factor.

To make possible the achievements of the fighting pilots, and to solve aerodynamic problems continuous experiments with new engines were carried on behind the scenes. High performance and controllability were not achieved without the incessant labour of scientists and designers, who were not a little baffled by the conflicting and rapidly changing demands often expressed with emphasis rather than illuminating precision; by the time new features in design could be given air trial the original demand had changed out of recognition.

And for military requirements something more than controllability was required; for besides having to control the aeroplane the pilot had to examine maps, operate wireless, watch many instruments, navigate, care for his guns, and keep a perfect look-out. If the controls were temporarily released the aeroplane ought in some measure to look after itself; in other words, be stable. In 1914 the BE<sub>2</sub>, and later the FE<sub>2</sub>, aeroplanes were altered so as to be stable longitudinally in partial conformity with Busk's RE<sub>1</sub> design. They were thereupon called BE<sub>2</sub>C and FE<sub>2</sub>B; with these the fier's hands were free, and with them no less than seven airships were brought down, a result no doubt assisted

by the confidence which stability inspired in night flying. But it then seemed that stability impaired controllability. By 1916 so strongly did war pilots desire the maximum of control that for some time many looked upon stability with disfavour. Gradually, however, a neutral stability was found to be compatible with the desired control. An added safety was that stable aeroplanes would automatically tend to recover from a spin after loss of control, and that, unlike unstable aeroplanes, they would tend to return to a normal attitude if they became inverted unintentionally or during the course of violent manoeuvres. Great as was this advance in aerodynamic knowledge, problems equally great remain, the solution of which can only be reached by constant and arduous experiment.

*The Return to Peace.*—Civil aviation was mainly restarted by the conversion of war types, which were not so well suited as if designed for the purpose. Specialization of type commenced in two directions: aeroplanes destined for travel and transport and those designed for racing.

The year 1919 saw wonders as great as any that had gone before. On June 14th-15th Alcock crossed the Atlantic on a Vickers-Vimy with twin Rolls engines in 16 hours 12 minutes, by which he won the *Daily Mail* £10,000 prize, and for which he was knighted. Of Hawker's plucky attempt and descent into mid-Atlantic; of Alcock's battle with driving mist, cloud and darkness; of the navigation of Whitten Brown, his companion; above all, of the human endurance underlying the feat, it is impossible to speak in measured terms. Just prior to Alcock's achievement there was one of a different kind, a triumph of organization for the Americans; for Lt.-Comm. Read and his crew came from America to England via the Azores and Lisbon, including the remarkable passage of 150 m. under power on a rough sea, in the flying-boat NC4. In the late autumn Ross-Smith and his brother flew another Vickers-Vimy to Australia in 28 days, won the £10,000 offered by the Australian Government, and were both knighted.

High-powered racing aeroplanes again appeared. Janello, in an Italian seaplane, put up a fine performance for the Schneider Cup at Bournemouth at a speed estimated at 140 m.p.h., but, though virtual winner, had unfortunately to be disqualified. Gathergood won the Aerial Derby at 129 m.p.h. on a De Havilland aeroplane. Racing machines reached speeds of 170 and 180 m.p.h., and climbs were made to over 30,000 feet.

In 1920 Van Ryneveld flew from England to Cairo, and thence after many adventures to the Cape. He crashed two aeroplanes on the way, and arrived at his destination on a third supplied by the South African Government; but considering the conditions for flying in Central Africa his achievement is of the first rank.

The Schneider Cup and the Gordon Bennett, two classic races, were won respectively for Italy by Lt. Bologna in a Savoia seaplane at Venice with an average speed of 106 m.p.h., and by Sadi Lecoq at Etampes at 109 m. per hour. Courtney won the fifth Aerial Derby in a Martinsyde racer with an average speed of 153 m. per hour. At Etampes the Farman "Goliath," a large passenger machine, remained aloft for 24 hours 19 minutes, beating all duration records. In America Maj. Schroeder on a Le Père biplane with a supercharged engine reached a height of 33,000 feet. The fast American and French racers continually raised the speed record, until Sadi Lecoq on a Nieuport reached 313 km. per hour over a measured kilometre. By the end of 1920 racing machines had reached a speed of nearly 200 m.p.h., a military type scout had climbed to 20,000 ft. in 15 minutes; a large commercial machine had climbed to 15,000 ft. with a weight equivalent to 26 passengers, fliers had climbed over six miles into the air, and an aeroplane had remained aloft for over 24 hours.

To promote safety, experiments were carried out to reduce landing-speed while retaining a reasonable top speed by means of wings variable in flight, a problem to the solution of which Handley Page offered a notable contribution. In spite of these and other difficulties so little risk now remains that the number of miles flown for every accident is something like 35,000, or one-and-a-half times round the world.

The years from 1909 to 1920 reveal a story of progress that, even allowing for the extraordinary stimulus of the World War,

is surely without parallel in the annals of engineering. And in this story may be found the hint of a tremendous future.

See also:—*The Royal Aero Club Year Books* (1911-9); *Flight* (Jan. 1909 to Dec. 1920, the Official Organ of the Royal Aero Club); Captain McCudden, *Five Years in the Royal Flying Corps* (1918). (R. M. H.)

II. DEVELOPMENT OF AEROPLANE DESIGN

**Design of Lifting Surfaces.**—The determination of the forces acting upon a body moving through a viscous fluid, such as the atmosphere, is a problem so far not amenable to mathematical solution, and design must therefore be based upon experiment. A vast mass of experimental data has been obtained by testing models in wind tunnels (by Eiffel in Paris, by Prandtl at Göttingen, at the National Physical and other laboratories) and by experiments upon aeroplanes in flight, principally in England at the Royal Aircraft Establishment, Farnborough. A very useful amount of information had been acquired before the war, but this has been greatly extended during the war period.

Lifting-surfaces of various shapes have been used in the design of aeroplanes, disposed in a variety of ways. It was immediately evident that the span or spread of the wing across the line of flight should be large in comparison with the "chord" or dimension along the flight path. The ratio of the span to the chord has been termed the "aspect ratio." Aerodynamic efficiency increases with increasing aspect ratio; but it is desirable to limit the aspect ratio for constructional reasons and in order to reduce the room required for housing. The greater aerodynamic efficiency, moreover, becomes neutralized after a point by the head resistance due to the additional external bracing required. A compromise must be made, and the average figure used is in the region of six to one. It was also evident that the wings should be cambered along the line of flight. The early aeroplane wings had approximately the same curvature of upper and lower surfaces. Wind-tunnel experiments, however, showed that the curvature of the under surface had but small influence compared with that of the upper surface, a result which enabled the designer to increase the thickness and internal strength of the wings and reduce external bracing.

Extensive wind-tunnel research has been carried out to find the best cross-section shape of wings. Greater lift can be obtained from highly cambered wings, but thinner wings offer less resistance to motion at small angles. An aeroplane should have as large a speed range as possible. While a wing of high lifting-capacity is required to fly slow, small resistance is required for fast flying, that is at fine angles of attack. A greater speed range is obtained by the use of wings of small curvature (about  $\pi$  in 15), the same lower limit being attained by the use of a larger area to carry a given weight. Wind-tunnel experiments further determined the extent to which the curvature should be greater towards the leading edge of the wing.

Early writers sometimes stated the requirements of a wing as consisting purely of a high ratio of lift to resistance at some angle of attack. The requirements are in reality more complex. To secure a wide range of speed a high ratio of lift to resistance is required at fine angles (fine in comparison with the angle at which the wing attains its greatest lift at a given speed) and in addition a high value of this ratio is required at the intermediate angle at which the aeroplane climbs. This is not all. For longitudinal stability the travel of the centre of pressure when the angle of attack varies should be small, as this travel on a curved surface produces instability. The wing section best meeting all these requirements is probably the British Royal Aircraft Factory's No. 15, designed early in 1916.

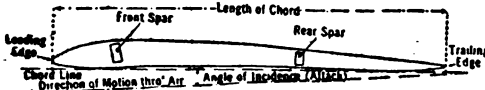

FIG. 6.—Wing Section R.A.F. 15.

The resistance of a wing must, however, be considered in relation to the resistance of the external bracing attendant upon

its use. It has been suggested, that the thick wing, in spite of greater head resistance due to the wing, might prove superior by making possible the suppression of all external bracing, and

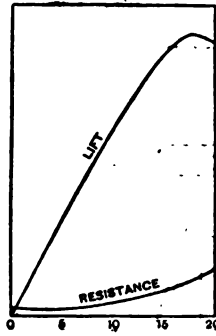

FIG. 6a.—Variation of the Lift and Resistance of a wing with Angle of Attack.

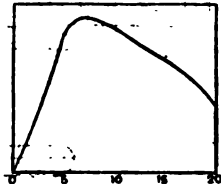

FIG. 6b.—Variation of the ratio of lift to Resistance for the wing alone as the Angle varies.

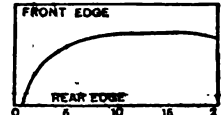

FIG. 6c.—Travel of Centre of Pressure as Angle of Attack varies.

the German Junker and others have designed aeroplanes on these lines.

The term "wing" is commonly used of the half of a lifting-surface on one side of the aeroplane, the whole surface constituting a "planc." Thus a monoplane has one pair of wings. A tandem aeroplane has two or more pairs of wings arranged as the name implies. The terms "biplane," "triplane," "quadriplane" denote that two, three, or four planes are superposed. Langley's "aerodrome" is an early example of the tandem aeroplane. This type is inconvenient structurally and aerodynamically very inefficient. The rear plane acts upon air to which a downward trend has been imparted by the plane in front. The reaction upon the rear plane is therefore inclined backward by the angle through which the air has been "downwashed" by the leading plane. In multiplane systems in which the planes are placed one above the other, each plane operates in air whose motion is influenced by the others, and the ratio of resistance to lift is less than the ratio which each would experience if acting alone. If, however, the planes are placed at a sufficient distance apart, so that the gap between is roughly equal to the chord of the planes, the mutual interference produces an effect comparable with that due to a reduction in aspect ratio such as is found necessary in the design of a monoplane. Using the same aspect ratio a given area is disposed in a biplane in half the span required in a monoplane. The biplane forms a good structure, the planes forming the flanges of a box girder. In the monoplane the bracing wires make small angles with the planes, with consequent high tension in the wires and high compression in the spars of the wing. In the biplane the wires make obtuser angles with the planes. In reviewing the examples of the two types, it is found that the monoplanes are relatively of heavy wing loading and low aspect ratio. In the triplane the upper and lower planes may form the flanges of the girder, or the structure may consist of two girders superposed. This does not possess the same structural superiority over the biplane, as does the latter over the monoplane. The triplane arrangement provides a means of reducing span by increasing height. An early example of the triplane is that designed and flown by A. V. Roe in 1909. A Sopwith triplane was used by the British army during the war. The type may be suitable to large aeroplanes, in which reduction of the weight of the structure and of bulk is especially needed.

The great majority of aeroplanes have been of the monoplane and the biplane types, the latter predominating since 1912. The first aeroplanes to fly were biplanes and by far the larger number of aeroplanes in use to-day are of this type. The monoplane appeared about the opening date of the period under

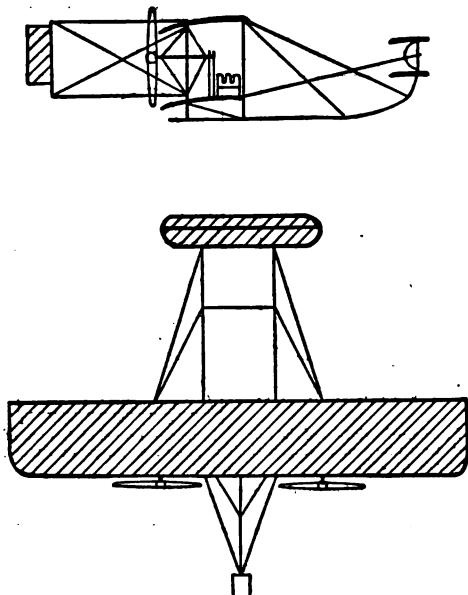

FIG. 7.—Early Wright Aeroplane. (Propeller Biplane.) (Elevators in Front; Rudder in Rear.)

discussion, and on an aeroplane of this type Blériot crossed the Channel in July 1909. It was more cleanly designed than the biplane of that date and was regarded as the faster type. It was largely used for trick flying, and figured ever more widely in aeronautical exhibitions. At the outset of the war it had still a reputation for speed, but had found a rival in the better de-

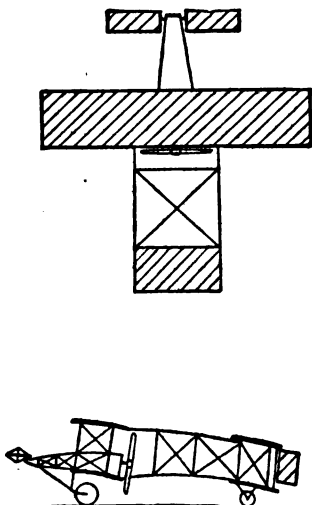

FIG. 7a.—Early Farman Aeroplane. (Propeller Biplane.) (Elevator in Front; Rudder in Rear.)

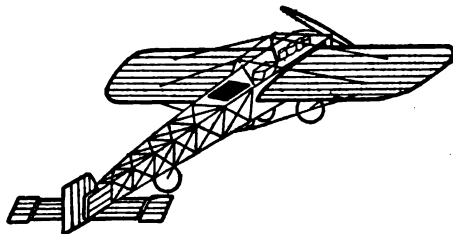

FIG. 7b.—Early Blériot Aeroplane. (Tractor Monoplane.) (Elevators and Rudder in Rear.)

signed "tractor" biplanes. During the war the monoplane was more largely used by the French and the Germans than by the British. The names most associated with the monoplane are French: Blériot, Morane, Nieuport. The "Fokker" monoplanes used by the Germans take their name from a Dutch designer probably inspired by the French designs. During the years 1914-8, the biplane was in the ascendant, but the monoplane was afterwards revived in the form of the aeroplane with thick "cantilever" wings without external bracing. The monoplane appears to be a type convenient in small sizes, but unsuited for the larger aeroplanes.

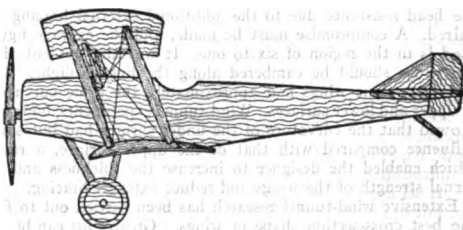

FIG. 8.—Modern Tractor Biplane.

*Position of the Airscrew.*—Airscrews have been described as "tractor" or "propeller" according as the airscrew shaft is placed in tension or in compression by the thrust, and corresponding aeroplanes are usually called by the same names. The first biplanes, those of the Wrights and the Farman, were of the "propeller" type, colloquially "pushers"; almost all monoplanes were "tractors".

In the tractor, monoplane or biplane, the order of disposition of the component parts is generally from front to rear:—airscrew, engine, crew; and the body is prolonged to carry stabilising and controlling surfaces at the rear. In the pusher the order is reversed and the controlling surfaces are carried on an open frame ("outriggers") in front, at the rear, or in both positions.

On a "pusher" the field of view forward is superior, and great stress was laid upon this by the British War Office after the military trials in 1912. The necessity of aerial fighting was proved in 1914, and the tractor was found unsuitable owing to the obstruction in the most effective direction for firing. Pushers were therefore ordered for fighting, at first carrying pilot and gunner, and later carrying only one man with a machine-gun fixed in the aeroplane. The situation was completely altered by the device of firing through the airscrew disc. The blades were at first protected by deflector plates, but shortly after mechanism was used to time the fire between them, the invention of Constantinescu, a Rumanian. The aeroplane was directed bodily at the target. The "tractor" then replaced the "pusher" fighting aeroplane; but "propeller" airscrews continued to be used on seaplanes, on aeroplanes for night duty against Zeppelins, and on large twin-engine aeroplanes.



The "tractor" is the more convenient design, slightly better aerodynamically and reputed safer in a "crash."

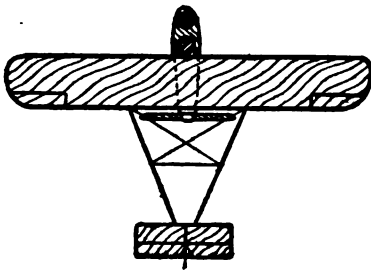

FIG. 9.—Propeller Biplane of 1914-16.

**Weight and Head Resistance.**—The aeroplane designer is continually interested in the relative importance of weight and head resistance. At the start attention was naturally concentrated upon the production of a light structure. Knowledge of the resistance to motion of bodies of various shapes was meagre and was most probably gauged in the mind of the designer by the frontal area exposed, irrespective of shape. It was not realized that a strut of circular section offers twelve times the resistance of a strut of the best "streamline" or "fair" shape of the same frontal area. The light biplane structure of the Wrights and the Farmans contained a network of struts and wires offering a very high resistance. To reduce resistance, exposed parts may be "faired," which involves adding weight; and the number of external parts may be reduced, which again increases the weight of the structure. Wrights and Farmans may be contrasted with the fast monoplanes and biplanes, the latter employing only a single bay of struts on either side, and finally with the unbraced monoplanes of Junker and Fokker.

"Streamline" wires were first designed for the British army dirigible "Beta" in 1912, and fairshaped wires were in 1914 fitted to aeroplanes designed at the Royal Aircraft Factory. They have since become the most usual bracing of British aeroplanes. They offer approximately one-eighth of the resistance of cable of the same tensile strength. Their metallurgy required careful study, and hence in other countries cable has continued to be used, frequently duplicated, the cables lying one behind the other with a wood "fairing" between them. Struts of streamline shape were in use at an earlier date. The bodies of aeroplanes have improved in form, the crew has been protected from wind pressure, and the spokes of wheels have been covered in with fabric.

The drag of a biplane of moderate speed is made up roughly as follows:—

Main planes	30%
Bracing of main planes	20%
Body	30%
Undercarriage	15%
Tail surfaces	5%

These figures show the importance of careful design of all parts. Much of the resistance of the wing-bracing occurs at the joints of wires and struts to the planes, and the resistance of the body is largely due to the necessity of cooling the engine, either by water radiator or by flow of air over the cylinders.

The weight of the complete structure, excluding the power unit, fuel, crew and other load borne, is about one-third of the whole weight of the aeroplane, but varies with the total weight, with the weight carried per unit of area of lifting surface, and with the strength of the structure. The following figures are averages for a number of British aeroplanes:—

Total weight	2,000 lb.		10,000 lb.	
Area of lifting surface	335 sq. ft.	200 sq. ft.	1,700 sq. ft.	1,000 sq. ft.
Load borne per unit area	6	10	6	10
Load factor	4   8	4   8	4   8	4   8
Structure weight of % of total weight.	28   35	27   34	31   40	29   37

The "load factor" is the number of times the weight of the craft which the wings will support; a measure of the strength.

Using one of the light engines now available, the power unit to give a speed of 100 m. an hour will weigh about one-quarter of the total, leaving 40 to 45% for fuel, crew and cargo.

**Wing Loading and Horse-Power.**—The lift of a wing is proportional to its surface, the atmospheric density, the square of the speed and the angle at which it meets the air measured from the angle giving no lift and up to an angle near that known as the "critical angle." At this angle the lift is a maximum (if the other factors be supposed constant) and above it the lift decreases. The wing in passing through this angle is said to be "stalled." Stalling occurs when flying as slowly as possible. After stalling it is no longer possible to increase the lift by depressing the tail of the aeroplane and it is necessary to dive in order to recover flying speed. This has been a frequent cause of accidents when flying too low to have room for a dive. Moreover, the wings when stalled have lost their normal tendency to oppose rotation about the line of flight and now tend to "auto-rotate" or act as a windmill. The aeroplane may therefore drop one wing and pass into a steep spiral glide known as a "spinning nose-dive" from which it may be brought to normal flight by the same diving process reducing the angle of attack of the wings. There is no danger in the stall or the spin so long as there is space for the recovery and knowledge of the action required.

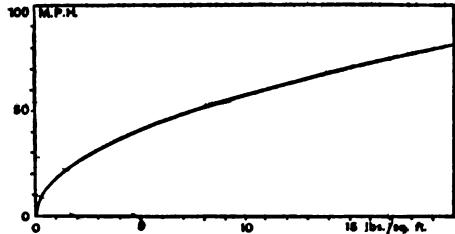

FIG. 10.—Curve showing lowest speed of flight possible with given wing-loading and the usual thin wings.

Wing-loading, the weight borne per unit area of sustaining surface, determines the speed at which the wings become stalled and therefore the slowest slighting speed. With constant loading, as the speed of aeroplanes increases, wings attack the air at ever finer angles, very soon passing the angle of lowest resistance for a given lift. To increase speed it therefore becomes desirable to increase the loading, or in other words to reduce the area of the wings. This reduction has also the merit that it reduces the bulk of the craft, the resistance of external bracing and the weight of the wing structure. To attain the greatest height heavy wing-loading is not required, and the best loading for a high ceiling would to-day be considered a light loading. For fighting, power of rapid manoeuvre is essential. The aeroplane of light loading can be turned in a smaller circle. The total weight is, however, approximately fixed by military considerations, and light loading implies large wing area and consequent greater resistance to angular acceleration, so that the lightly loaded aeroplane cannot so quickly be "banked" to the correct angle for the turn. Given the wing area, the aeroplane having the lighter loading is the more manoeuvrable; given the weight, the heavier loaded aeroplane is at least the equal of the other. Aeroplanes carry a larger area of sustaining surface than they require, except for alighting, and it is the



difficulty of bringing the aeroplane to land at high speeds which prevents the increase of loading beyond 10 lb. to the square foot.

In commercial use, economy dictates an increase of loading; safety demands that the aeroplane may alight at speeds and in a space impossible with high loading. Attempts have been made to make the wing area or the wing shape variable in order to reduce the lowest speed of flight, while retaining the other advantages of heavy loading. None has so far been successful.

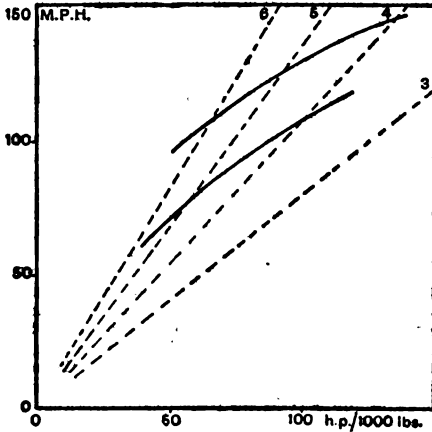

FIG. 11.—Diagram showing speeds attained by British aeroplanes at a height of 10,000 feet. The speeds vary between the upper and lower curves. The base is engine power at ground level per 1,000 pounds of total weight. The dotted lines are lines of constant ratio of tractive force to weight, marked with the values of this ratio.

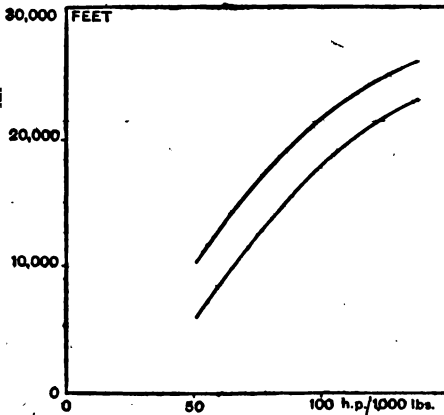

FIG. 12.—Diagram showing greatest effective height attainable by British military aeroplanes. These vary between the upper and lower curves. The base is engine power at ground level per 1,000 pounds of total weight.

During the period 1909 to 1921 the speed attained by aeroplanes was more than doubled. The rate of climb and the height attainable have increased in a larger ratio. Greater knowledge and better design have improved the aerodynamic efficiency of the aeroplane; but the improvement of performance is in the main due to the use of larger engines. In 1918 four times the power was being used that was used in 1914 for the same

purpose—the reconnaissance two-seater aeroplane—and the speed is more than half as great again. Aerodynamically there is little difference between the two aeroplanes. As the power of engines grew their weight per horse-power was reduced. To save two pounds in every four on an engine weighing one-third of the whole aeroplane was important.

The largest engines developed were insufficient for the larger aeroplanes, into which two engines were commonly built, and in some cases four or more.

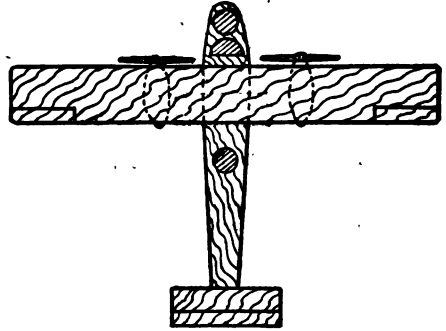

FIG. 13.—Large Twin-Engine Aeroplane.

Two separate power units have been regarded as conducive to safety. Experience has so far not confirmed this. It is essential that the power of one engine alone should be sufficient to fly the aeroplane, and the "twin-engine" aeroplanes used during the war were not all provided with so large a total power. Again, the engines were carried on either side of the centre and the line of thrust of each offset by a considerable amount. This introduced difficulties of control, because rudders were unable to balance the offset line of thrust at the low speed at which the aeroplane could be flown level on one engine only, and there was danger in the event of sudden failure of one engine near the ground.

The table gives some particulars of a few typical aeroplanes through the period under review. The figures are approximate:—

Name	Date	Flying weight lb.	Lifting surface sq. ft.	Horse power	Wing load lb. per sq. ft.	H.P. per 1000 lb.	Speed, m.p.h.
Wright . . .	1908	1,000	540	25	1.8	25	40
Farman . . .	1908	1,150	560	40	2.1	35	30-40
Bleriot . . .	1909	670	168	25	4	40	
Roe triplane . . .	1909	400	320	10	1.25	25	
Dunne . . .	1910	1,700	560	50	3	30	40
Cody . . .	1911	1,400	690	50	2	35	40
Roe biplane . . .	1911	750	280	30	2.7	40	40
The horse-power and speed given above are uncertain.							
Aeroplanes in British War Office trials 1912 . . .		1,500		45	2.9	35	Up to 80
		2,150		120	9.5	55	75
BE2C . . .	1914-5	2,140	370	100	5.8	46	80
Bristol Fighter . . .	1916-7	2,800	400	250	7	90	115
SE5a . . .	1916-7	2,000	250	210	8	100	130
Sopwith Camel . . .	1916-7	1,480	230	125	6.4	85	110
Handley Page 0/400 . . .	1916-7	14,000	1,640	550	8.5	40	80
De Havilland GA . . .	1918-9	4,220	490	400	8.5	95	125
Martinsyde F4 . . .	1918-9	2,290	330	300	7	130	145
De Havilland 10A . . .	1918-9	9,000	850	810	10.5	90	120
Handley Page V/1500 . . .	1918-9	24,100	2,900	1,440	8.3	60	90

The Large Aeroplane.—For the same aerodynamic performance, the lifting-surface of an aeroplane must be propor-

fional to the weight. If aeroplanes of all sizes were constructed of the same materials and geometrically similar in all parts, the weight of the structure would increase with increasing size as the cube of the linear dimensions, that is, as the  $3/2$  power of the total weight. This does not in fact obtain, because geometric similarity would give greater strength to the larger aeroplane; also the design may be elaborated and materials worked to relatively finer dimensions; and moreover, large aeroplanes are not designed to have the same strength as smaller craft, as they are less sharply manoeuvred. Nevertheless, the weight of the structure is to be expected and is in fact found to become a larger proportion of the total weight as the size increases. It is therefore disadvantageous to increase size indefinitely and there is in fact a best size depending upon the duty to be done.

To carry an indivisible unit of cargo, such as a large bomb, an aeroplane of at least a certain size is required; hence we find size increasing. Sometimes it is preferable to carry a total load in a smaller number of larger aeroplanes, because the weight of the crew becomes less in proportion to the cargo carried, so that every square foot of wing and every unit of engine power of a fleet carries more useful load. Initial outlay and fuel consumption are reduced and there is further an economy of pilots. At some point the larger aeroplane requires a larger crew, and for war the larger "bomber" must carry a number of gunners and offensive armament for defence against more mobile attackers. The optimum size for a commercial service with a sufficient volume of traffic is what would be termed to-day a large aeroplane (say 7,000 lb. at least). The actual size depends to some extent upon the speed of the service, which governs the relative costs of fuel and personnel, and also upon the distances.

The first large aeroplane flown was the Russian Sytkorsky in 1913. Large aeroplanes were demanded in 1915 for bombing and were increasingly used during the war. The Handley Page (13,000 lb. gross) was extensively used by the British. The "Gotha" and others were used for raids on London. The same Handley Page aeroplanes and a subsequent design were employed on a passenger service between London and Paris throughout 1919 and 1920. The "Vimy" (12,500 lb. gross) crossed the Atlantic, flew from Cairo to the Cape, and from Europe to Australia, and has been used on a London-Paris commercial service.

**Controlling Surfaces.**—Stability in aviation is discussed in Section III. Complete inherent stability is obtainable by a proper distribution of weight and subsidiary surfaces and suitable arrangement of the main planes. The planes are commonly inclined upwards from root to tip to secure a righting couple if one wing tip falls and the aeroplane begins to sidelisip. A vertical surface at the rear, known as a fin, is general although the rudder may entirely replace this surface. The travel of the "centre of lift" of the wings is such as to produce instability, and a subsidiary horizontal surface is required either in front or in the rear. To secure "longitudinal" stability, the centre of gravity must be sufficiently forward in relation to the main planes, and the load on the subsidiary surface maintains equilibrium. The aeroplane has three degrees of angular freedom and has almost invariably employed three means of control: elevators, to produce a "pitching" motion, and so govern the angle of attack of the wings and the speed of flight; rudders to produce motion about the vertical axis; and warp or ailerons, to secure lateral balance and adjust the angle of "bank." The early Voisin aeroplanes had no control for lateral balance. The aeroplane when turning has a natural tendency to bank, which is accentuated or reduced by sidelisip outwards and inwards respectively if the wings are inclined upwards from root to tip or fitted with a vertical surface above the centre of gravity. The Voisin aeroplane carried curtains between the planes to provide this righting couple and was sufficiently controllable for the requirements of the pioneer content to achieve flight. "Lateral" control is desirable and is clearly necessary for rapid manoeuvring. The Wrights obtained this by twisting or "warping" the wings, and this method was extensively used up to the end of 1914. Control has been more generally obtained by means of hinged portions of the wings at the rear near the wing tips.

Elevators have been placed both in front and in the rear: rudders always in the rear. They have constituted the whole, or only a part of, the necessary stabilizing surfaces. Control with a single rudder requires an effective "keel" surface, which is adequately provided by the body of the aeroplane and the exposed struts of the structure. The tendency of design towards the "tractor" type places elevators and rudders most conveniently at the rear end, and this gives a

clear field of view forwards. The early biplanes with an elevator in front and rudder at the rear disappeared about 1914; the monoplanes conformed to the modern usage. Both elevators and rudders are usually hinged portions of fixed surfaces, but in some cases the entire surface has been movable and constituted the elevator or rudder. The latter arrangement has not provided stability if the controls were abandoned. Later the fixed horizontal surface was made adjustable by the pilot during flight and known as a "trimming tail plane," a device much used by the British from 1916 onwards. It enabled the pilot to vary the speed of flight at which no pressure upon the controlling lever was required, and effectively increased the range of control resulting from the application of a definite force.

The arrangement of control levers or wheels, at first very diverse, became standardized in 1915-6, and consists of a "rudder bar" operated by the feet and a hand lever whose fore-and-aft movement operates the elevators and whose lateral movement provides lateral control. The rudder bar and the lever are moved in the direction in which it is desired to move the aeroplane. In larger aeroplanes rotation of a wheel mounted on the fore-and-aft lever actuates the ailerons, the fore-and-aft control remaining as before. The lever or wheel is generally connected to the control surfaces by steel cables, although shafts in torsion and tension or compression members have also been used.

Balanced control surfaces, although in use from an early date, only became necessary as the size of aeroplanes increased. A part of the surface to be balanced is carried in front of the hinge and this surface is most frequently the rear portion of a fixed element, the part brought forward of the hinge being extended beyond the end of the fixed element. This so-called "horn" balance proved unsatisfactory. If a large "horn" were used (adequate to give ease in normal flight), there was overbalance at low speeds, or when the aeroplane airdeslipped, and the controls would then tend to "take charge." A more uniform effort results if the balancing projection is run the full span of the hinge, which must then be set back behind the fixed element. The front edge of the balanced surface is sharp and its movement takes place behind the bluff end of the fixed element. Alternatively, separate balancing surfaces in advance of the hinge have been rigidly attached to the moving element and placed above the fixed element.

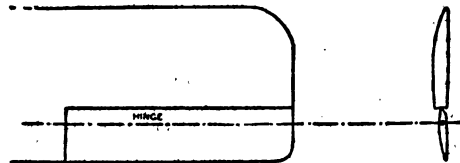
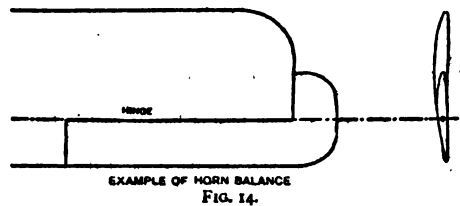

Two Methods of Balancing Ailerons.

The imperfection of balancing obtained has led to the development of relay motors to reduce the effort. In these, power derived from the air by a small windmill is brought into play whenever the pilot attempts to move the controls. Relay motors had been but little used up to 1921.

**Chassis or Undercarriage.**—The Wright aeroplane alighted upon skids. It was launched by a catapult. The French pioneers took the air under their own power, and the Farman and Blériot used wheels. From 1909-14 combined wheels and skids were used. The wheels were commonly sprung by means of rubber cord. The skids might be brought into action if the alighting were imperfectly executed, and were carried well forward to prevent the aeroplane from turning over forwards when landing. Sometimes additional wheels were fitted in a forward position in place of the skids for this purpose. Under the tail a wheel was often fitted, but a small skid was used alternatively. Wing-tip wheels or more commonly light skids were used to protect the wing tips from contact with the ground. In Blériot's

undercarriage the wheels were mounted as castors to facilitate landing across the wind. This was subsequently abandoned.

The common arrangement of undercarriage comprises a pair of wheels a little forward of the centre of gravity of the aeroplane and a small tail skid. The wheels, of wire-spoke construction with pneumatic tires, are carried on an axle of steel tube attached to two V-struts from the aeroplane by rubber cord. The tail skid is also sprung by means of rubber and is mounted on a swivel. Steering on the ground was improved in 1912 by arranging the tail skid to be moved by the rudder bar. The use of skids and wheels ahead of the main wheels was generally abandoned early in the war, except in the case of large aeroplanes.

Steel springs have been used, but rubber is superior to steel because it stores more energy for a given weight. Hysteresis in rubber is also much greater than in steel. To avoid bouncing after the first shock the energy received on impact should be restored as little as possible. This requirement led to the design of undercarriages containing a combination of steel spring and oil dashpot, such as the "Oleo" design fitted to the Breguet and to the Royal Aircraft Factory's "BE2" in 1914. This form of "shock absorber" was chiefly useful for night flying.

**Methods of Construction.**—The first experimenters built their aeroplanes of wood and fabric with metal at joints and in the form of piano-wire bracing. The aeroplane of to-day uses spruce for beams and struts and steel for joints and tension members, the latter in the form of stranded cable, or "rafwires," i.e. rods rolled to a "streamline" section. Wings and body are covered with linen, pulled taut by "dope," and varnished or painted for protection from sunlight and moisture. Frames composed entirely of metal were used as early as 1911, but wood remains in general use, except for the tropics. Steel tubes have been extensively used in parts, notably for the part of the body to which the engine is attached, for struts between the planes, and in the undercarriage. The use of steel tubes for the engine-bearers gave place to wood owing to the greater absorption of vibration obtained.

The wings in the common type of biplane contain two wood spars of I or box section forming the flanges of a truss braced by wood or steel struts and cables or solid wires. To these spars are attached transverse ribs which give the shape of the wing and a light wood edge completes the frame. The linen covering is sewn on to this with a seam along the rear edge; stitched to every rib since 1914. The body is most often a frame of wood compression members and wire bracing. Bodies built of three-ply wood, with or without reinforcing members, have also been used. These retain their shape better and, being infinitely redundant structures, have perhaps some advantage against rifle fire; but the former have been preferred apparently as being more easily repaired and inspected and allowing of a more certain calculation of stresses.

Metal construction advanced further in Germany than in other countries. Junker produced aeroplanes without external bracing, strength being obtained by the use of thick wings. These contained in place of the usual two spars a number of steel tubes interconnected by tubes forming triangles. The wings were covered with aluminium sheet corrugated so that the air flowed along the corrugations. The interconnecting tubes and the corrugations replaced the usual ribs. Great Britain has experimented with spars and ribs of steel and duralumin, and secured the necessary strength without increase of weight; but metal construction is still in the experimental stage. The principal difficulty in the use of steel lies in the prevention of local buckling due to the thin gauge of metal required to secure a light structure. Welding is unreliable owing to the impossibility of detecting weakness in the finished part, and joints are made by rivets or bolts. Bodies have been made of duralumin on the same lines as those built of three-ply wood.

**The Strength Required in the Structure.**—The aeroplane structure is subjected to a very variable load. In straight flight the wings support the weight of the craft. A sudden gust, or change in the direction, or speed of the relative wind, momentarily increases or decreases the load. To estimate the extent of this, the proportion which any possible gust bears to the speed of flight must be known. On a banked turn or when returning to level flight after diving, the wings must provide an accelerating force, depending upon the rate of turn and the speed of flight. The pioneers were content to fly warily, and the accelerations necessary when they turned were small. The larger variations in loads were due to gusts. They flew only in the calmest weather, but their speed was slow. As soon as the aeroplane was used for trick flying, the effect of gusts became relatively insignificant, and the accelerations due to manoeuvres

were the necessary basis of design. In an aerial combat the wings may have to sustain over three times the normal load, and it is not practicable to design a fighting aeroplane for the accelerations which could be produced by flattening out too rapidly from a steep dive, in which a speed of over 200 m. an hour may be reached.

The determination of the load variation possible is one part of the problem of specifying the strength required of the wing structure. We must also know how this load is distributed over the surface, along and across the wing, and how it is shared by the different members of the structure. The important factor is the variation of the "centre of pressure" on the wing. As the angle between the wing and the direction of motion decreases the centre of pressure moves backward with increasing rapidity. It may be noted here that in a nearly vertical dive at high speed, although the lift of the wings is small, there is a large couple acting upon them tending to twist them and to turn the aeroplane over on its back; this is resisted by the action of the tail. A number of the early accidents occurred in the course of a "vol piqué," or steep dive.

Rough calculations were probably made of the strength of the early aeroplanes, and in 1911-2 those supplied to the Government were tested by inverting them and loading the wings with sand. Spars of wings were also tested separately, but as a rule both the strength required and the strength realized were uncertain quantities. A number of accidents to monoplanes led to this type becoming suspect. Early in 1912 Blériot forwarded a suggested explanation to the French War Office, which resulted in the suspension for a few months of the use of monoplanes by the French army. Later in the year accidents to monoplanes in England led to a suspension of their use by the War Office, although the navy continued to use them. A committee was appointed and reported early in 1913. It decided that the accidents were due to the construction of these monoplanes, but not to anything inherent in the monoplane system. They recommended that the wings should be braced internally against drag (a remarkable omission previously), the main bracing wires duplicated and made independent of the undercarriage, and the fabric well fastened to the ribs, especially on the upper surface. Makers were to supply evidence of strength; official inspection and investigation of accidents were instituted; and the question of stability and the danger of the "vol piqué" and recovery were to be investigated.

Prior to this, efforts had been made in England to impose a factor of strength based on the load in straight level flight through steady air. The same factor has since been termed the "load factor." In 1914 the British Advisory Committee for Aeronautics issued a report on "factors of safety," regarding the load factor as the product of two factors, one representing the number of times maximum load might exceed the normal load, and the other a factor to cover possible faults of material and workmanship. The first factor is based on the acceleration due to a banked turn combined with a gust, and to recovery from a dive. Forty-five degrees was the steepest angle of bank considered advisable and it is recommended that to secure safety aeroplanes should not be dived to a speed exceeding the normal by more than 20 per cent. The committee advised that the structure should have a factor of safety of at least 2 under the acceleration so obtained. A factor of from 6 to 8 (which had been worked to by the Royal Aircraft Factory since 1912) was recommended, to be increased to 12 if this should become possible. There is no record of the obligatory use of such factors in France or Germany at this date.

During the war the problems involved were investigated both mathematically and by experiment. Loops and mock fights were carried out at the Royal Aircraft Factory by aeroplanes fitted with an accelerometer and with tension meters on the wires. The distribution of pressure over wings has been measured in wind tunnels (first by Eiffel in Paris) and on aeroplanes in flight at Farnborough. It is now possible to specify the strength of the various members of an aeroplane with sufficient accuracy for any manoeuvres required. The "load factor" demanded has never risen to 12, but now ranges from 4 to 8, the lower factor for the large aeroplane which is not so violently manoeuvred. The adequacy of these factors has been confirmed by experience.

The need for extreme lightness precludes the use of the factors of safety currently used in other branches of engineering, and instead accuracy of stress calculation and careful inspection and testing of materials are imposed. It became the practice of the British Government to check by its own officials the strength of each design by detail calculations of stresses and by a proof load on one aeroplane of a type. Other governments followed. Since 1912-9 Great Britain requires that an "air-worthiness certificate" be obtained before a type may be used for commercial purposes. Drawings are submitted by the applicant from which calculations of stresses are made by the Air Ministry.

The calculation of stresses proceeds upon the usual lines, common to other branches of engineering, but with rather greater accuracy of detail. The theorem of Three Moments is applied to the spars, which require treatment as beams continuous through a number of supports and subjected to end load. Aeronautical practice has somewhat extended this theorem. A theory of the strength of struts of tapering section has been evolved. Knowledge of the mechanical properties of timber has been much extended.

**The Airscrew.**—The Rankine-Froude theorems on propulsion by the sternward projection of a stream of the surrounding fluid by the use of a screw-propeller, or other means, are well known. They state that the highest efficiency is attained by the projection of the greatest amount of fluid at the lowest speed, and indicate the use of propellers of the greatest practicable diameter. The only waste considered is the kinetic energy imparted to the fluid. An upper limit of efficiency is thus determined in terms of the diameter and the thrust of the propeller and the speed of motion. The design of marine screws proceeds mainly upon empirical lines based upon experience. The early airscrews were designed by a similar process of trial and error.

F. W. Lanchester (*Aerodynamics*, 1892), regarding the airscrew blade as a twisted aeroplane wing rotating about one tip as it advances through the air, assumed that the total reaction may be obtained by integrating the forces which would act upon elements at successive radii if these were elements of a complete wing. This method of treatment, which was also advanced by Drzewiecki, has provided the basis of airscrew design. As first applied, the theory was incomplete, chiefly because it ignored the fact that the blades in following each other act on disturbed air. For example, if the number of blades be increased, the theory indicates no fall in the efficiency, and reactions directly proportional to the number of blades, which experiment showed to be untrue. Moreover, the efficiency so calculated might exceed that given by the Rankine-Froude theorems. It was therefore sought to combine the two aspects of the action of the airscrew in one theory, and the further theorem of Froude that the stream has reached half the final velocity at the propeller disc appeared to provide a means of estimating the degree of disturbance of the air in which the blade acts. It is generally agreed that the original theory is over-corrected by this modification. The blade element under consideration is itself partly causing the acceleration of the stream, and this acceleration is the total and not merely the initial disturbance of flow in the neighbourhood of the element. Figures for the reaction on the elements were obtained by testing a small wing of the same section in a wind produced artificially in a "wind tunnel." This wing produces a disturbance of flow equivalent in an airscrew to an acceleration.

It was found in practice that the assumption of an arbitrary acceleration less than one-half of the final acceleration made it possible by the use of the theory of Lanchester to predict the aerodynamic performance of an airscrew with a valuable accuracy. The combined theory leads to two important conclusions, completely verified by experience. Firstly, the efficiency increases with increasing ratio of the pitch at which the screw operates to its diameter up to an optimum value seldom employed in practice. Secondly, for given thrust and speed the diameter must be so large that it acts upon a sufficient mass of air per unit of time to attain a satisfactory efficiency. The latter brings the theory into conformity with the law of Rankine and Froude. The former in practice brings the airscrew designer into conflict with the designer of aeroplane motors. Higher crankshaft speeds are required to produce a light-weight internal-combustion engine than are demanded by this condition for high airscrew efficiency. This has resulted in a large number of aeroplane engines being arranged to drive the airscrew through a reduction gear. The point at which gearing becomes desirable in practice is not easily determined. It depends upon a number of factors. Among these are a small loss of energy in the gears, added weight and cost, various practical reasons for dispensing with additional mechanism if this is not of sufficient value and the adverse effects of the greater torque of the slower running airscrew upon the control of the aeroplane, which must be offset against the gain in airscrew efficiency. In this question is also involved the consideration of the strength of the airscrew to resist the stresses due to rotation. This imposes a limit upon diameter, decreasing as the speed of rotation is increased, which may result in a further reduction of efficiency for the high-speed airscrew.

During the war large aeroplanes were built for which single engines of the required power were not available. In so far as two engines were sufficient, these were placed on either side of the main body of the aeroplane, each driving a separate airscrew. It became necessary ultimately to install four engines in a few aeroplanes and these were placed in pairs driving two pairs of airscrews in tandem. The design of the rear propeller in this arrangement involves an estimate of the rate at which air is supplied to it by the screw in front. With the same limitation of diameter the efficiency of propulsion attainable is approximately the same as if the two engines were coupled and drove a single airscrew of the same diameter, but is less than would be obtained by the use of four separate systems of propulsion. The tandem system is preferred for reasons of compactness and the difficulties of control attendant upon the use of a number of lines of thrust.

The aeroplane propeller, unlike the propeller of ship or airship, is required to transmit the full power of the engine at different speeds of flight, both when the craft is flying level at full speed, and when it is flying slow in order to climb. The airscrew cannot be designed to discharge both functions in the most efficient manner possible in each case. This was of little consequence in the early days of flight when the range of flying speed was small; but as the range was increased, some attention was paid to the design of airscrews of vari-

able pitch. These have been experimented with, notably at the Royal Aircraft Establishment, with some success; but they have not been used so far in service. If any device for preventing the loss of engine power with increasing height by an initial compression of the charge to ground-level density should come into use, the variable airscrew would become necessary. Such devices are, however, still in an experimental stage.

The number of blades in an airscrew is commonly two, but four blades have been extensively used. The two-bladed airscrew has an advantage in convenience for storing and transport. The use of more blades reduces vibration due to errors in blade angles, and eliminates gyroscopic vibration when the aeroplane is turning, and vibration due to aerodynamic causes both when the axis of rotation is inclined to the line of flight and when the aeroplane is turning. Airscrews have been almost universally made of timber, which should be continuous through the boss from blade tip to blade tip. This has prevented the use of three blades. In deciding the number of blades, two or four, the designer is largely guided by the blade area required, which depends upon the speed of motion of the blade and the power transmitted. Thus a slow-running airscrew has conveniently four blades, whereas for a high-speed screw two blades are preferred. A four-bladed high-speed screw might require such narrow blades that in order to resist the bending due to the thrust they would be so thick as to reduce the efficiency seriously.

At the speed of flight of an aeroplane the changes of pressure of the air flowing past the wings amount only to a small fraction of the atmospheric pressure. The blade tips of airscrews, however, commonly reach speeds of 800 ft. per second, approaching the velocity of sound in air. It follows that while the wings may be regarded as operating in a fluid of constant density, the compressibility of the air may have important effects in the case of the airscrew. With increase of blade speed effects must be anticipated similar to the phenomenon of cavitation experienced with marine screws. Such effects in a gas may, however, occur gradually with increasing speed. Experiments with small model wings in a wind tunnel in America showed a fall in lift and increase in resistance at speeds in the neighbourhood of 600 ft. per second at large angles, and it is clear that the distribution of low pressure over the upper surface cannot continue indefinitely. It appears, however, that airscrews so far designed have been free from any marked effect of this nature. The efficiency estimated has been attained in practice, although designers to a certain extent miscalculated the power required to drive airscrews as the speed of the blade tips was increased. The error cannot, however, be ascribed to the effects of compressibility owing to uncertainty as to many other factors involved. On the whole the method of aerodynamic analysis led to sufficiently accurate design.

The screw-propeller as a mechanism for the transmission of power is convenient and efficient. In the airscrew narrower blades can be used than in the marine propeller, and efficiencies as high as 85% have been attained with airscrews of high pitch and large diameter, smaller fast-running airscrews giving efficiencies of 75 per cent.

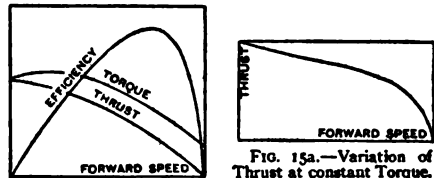

Fig. 15.—Variation of Thrust, Torque, and Efficiency of an Airscrew with forward speed at constant rate of revolution.

Owing to the light weight and high tensile strength of timber for its weight, the designer has found in wood his most convenient material. African walnut has proved the best timber when the stresses are most severe. Honduras mahogany is satisfactory for most purposes. Spruce and poplar have also been used, but are not suitable for higher powers and speeds. The screw is constructed of planks, or laminations, about an inch thick, glued together and cut to shape. The grain of the wood should be straight and run as far as possible along the blade. The method of construction secures a good approximation to this requirement. Timber has the advantage of large hysteresis and consequent power of damping vibrations. The Wright brothers' airscrews were made of spruce cut from a single piece of timber. An interesting design appeared in 1913 in the "Garuda" airscrew, of laminated wood construction with the blades tilted forward so that to a large extent stresses due to rotation neutralized those due to thrust. The forward tilt was obtained by bending the laminations during manufacture, a rather questionable practice. This method of balancing stresses has not

been developed beyond carrying the most forward lamination to the tip of the blade and succeeding laminations to smaller radii, owing to the method of construction and the nature of the material used. It has recently been stated that this forward tilt renders the blade liable to twist under load.

The stresses in the blades have been calculated by crude methods which give an approximation to the stress along the grain. Fracture has, however, almost invariably occurred across the grain, in the earlier airscrews, by failure of the glued joints. Workshop practice has now so far improved that the strength of glued joints is equal to the strength of even hard woods across the grain. The evident need for knowledge of torsional stress in an airscrew blade led to the practical solution by G. I. Taylor and A. A. Griffith in 1916 of the problem of torsion of prisms of any section. The mathematical equations had already been stated and the new development was the provision of an experimental method of solution. Theory can now indicate the shape of blade required to avoid twisting under the loads imposed in flight. Apart from the reduction of stress, this is of great value to the designer, who cannot with any certainty predict the performance of an airscrew if the blades twist in an unknown manner in flight.

In order to protect the blades from moisture the airscrew is varnished, or painted, and to protect against sand on land and spray on the sea, the tips have in some cases been sheathed in metal, but the practice of covering with fabric (dating from 1912-3) has recently found more favour. Japanese lacquer has also been used as a protective covering.

Several early airscrews (e.g. Breguet's) were entirely of metal, commonly aluminium blades bolted to a steel tube, a method only possible with the low powers and speeds of rotation of the period. Blériot crossed the Channel with a small, high-speed, laminated wood screw. Experiments with steel construction have proceeded slowly and steel may in time come into common use. Failure has been largely due to the unreliable nature of welding, and to brittleness produced in the process. For production in moderate quantities, wood requires far less outlay. A modern development is the airscrew with detachable blades, so far in a purely experimental stage. It allows of adjusting the pitch of the blades, if the airscrew has been imperfectly designed or the conditions of operation be altered, and of replacement of a damaged blade without renewing the whole. If the blades are of wood, shorter lengths of timber may be used, but it is doubtful if this can be regarded as an inherent advantage of the system, because the difficulty of attaching wood blades to a centre are probably as great as the difficulty of making a satisfactory joint at the centre of an airscrew constructed entirely of wood. The airscrew whose pitch is variable in flight is a particular case of the detachable blade screw, and the chief difficulty in the design of such a screw for high speeds of rotation is that of making the joint between the blades and the centre.

In Britain and in America airscrews have been tested before use in flight by "spinning" by means of an electric motor. This test has been applied to new designs, to airscrews whose strength has been suspected by an inspector, and to samples taken from batches. The practice was in force in this country in 1914 and has been continued. Flight conditions are not reproduced by the test, because the airscrew is not advancing through the air, and because the crank-effort variation and vibration of the engine are absent. The thrust loading is more severe, the centrifugal loading less severe. Experience has, however, given considerable confidence in the test. In France the only test applied has been a loading of the blades to counterfeit the air forces, without rotation.

**BIBLIOGRAPHY.**—British.—Reports and Memoranda of the Advisory Committee for Aeronautics (1909-19) and the Aeronautical Research Committee (H. M. Stationery Office); L. Baird, *Applied Aerodynamics* (1920); G. P. Thomson, *Applied Aerodynamics* (1920); A. J. S. Pippard and J. L. Pritchard, *Aeroplane Structures* (1919); H. C. Watts, *Design of Screw Propellers for Aircraft* (1920); E. C. Vivian and W. Lockwood Marsh, *A History of Aeronautics*; technical periodicals:—*Aeronautical Journal*; *Flight*; *Aeronautics*; *The Aeroplane*.

**American.**—Reports of the National Advisory Committee for Aeronautics (Government Printing Office, Washington); technical periodicals:—*Aviation*; *The Aerial Age*.

**French.**—G. Eiffel, *Nouvelles recherches sur la Résistance de l'air et l'Aviation* (1919); technical periodicals:—*L'Aérophile*; *L'Aviation*.

**German.**—Technical periodicals:—*Zeitschrift für Flugtechnik und Motorluftschiffahrt*. (R. MCK. W.)

### III. AERODYNAMICS

**Experiments and Calculations on the Principles of Flight.**—The recent history of the development of aeronautics rests largely on experiments on aircraft or models of aircraft and their parts. That branch of investigation which is least related to any other subdivision of engineering is the study of the forces which are experienced by a body when moving through the air. The air forces due to motion are dealt with under the general head of "Aerodynamics." A knowledge of air resistances is a primitive necessity in connecting the subject with the much older and well-established subject of "Dynamics."

In dealing with dynamics, the forces acting are frequently given by a simple fundamental law such as the theory of gravitation when accounting for the motion of planets and comets, and very many of the more complex reactions have been worked out. The corresponding fundamental theory of fluid motion has been known for more than half a century, but application to the determination of air resistances has proved to involve mathematical problems beyond the capacity of the times. Recourse has therefore been made to direct experiment, and in the early stages of aeronautical development almost every new idea could be tested. The number of variables under review has now grown so greatly as to exclude such a method on the ground of cost, and a period of fundamental experiment is being entered on. The object of such experiments is to find out what is happening to the air disturbed by the passage of a body in such a way that the results can be applied, with a reasonable degree of approximation, to a large number of related problems. Some success has been obtained in the case of airscrews, where the experimental data are so used that it is unnecessary to test every new design of airscrew. Extension to the aeroplane is gradually taking place.

For the same reason—expense—experiments on models have been used to cover the main field of inquiry, and the costly and frequently dangerous experiments on the full scale have, on the whole, been directed to crucial tests of the validity of the use of models. There has, of course, been a great amount of testing of aircraft in connexion with their value as fighting craft. At the present time, the value of such testing as an aid to design is very limited, detailed analysis being required to indicate lines of progress.

It then happens that the most comprehensive view of the subject of aeronautical principles is obtained from those aerodynamical laboratories which deal with experiments on models, experiments carried out under almost ideal conditions in the artificial air current of a wind tunnel. The theory of the use of models<sup>1</sup> becomes of great importance in aeronautics and has been studied extensively. When the maximum possible use has been made of the theory the position remains one for experiment, and full-scale coöperation is found to be essential for establishing a sound position. The theory of models has great value in showing the correct type of experiment and the method of comparison with the full scale. Finally, it is now known that when certain precautions are observed in model tests the applications to full scale have an accuracy sufficient to give them a high value as an element in progress.<sup>2</sup>

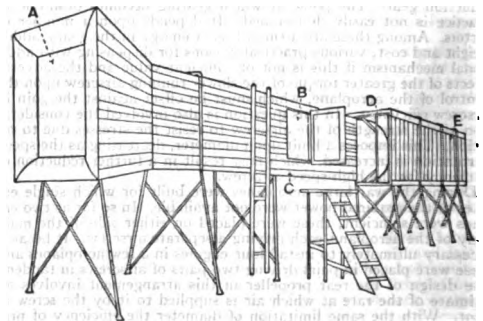

A. Air Intake B. Working Section C. Aerodynamic Balance  
D. Position of Airscrew E. Distributor

FIG. 16.—Wind Tunnel.

**Laboratory Experiments.**—(a) *The Wind Tunnel.*—The number of first-class wind tunnels in existence in the world in July 1921 was probably between twenty and thirty. Of these, seven were at the National Physical Laboratory at Teddington, three

<sup>1</sup> Report, Advisory Committee for Aeronautics, 1909-10, p. 38.

<sup>2</sup> Report, Scale Effect Sub-Committee A. C. A., 1917-8, R and M,

at the Royal Aircraft Establishment, Farnborough, and a number distributed amongst the private aeronautical firms of Britain.<sup>1</sup> America has a number of channels of generally similar type,<sup>2</sup> but with a unique example in one instance where the speed of the air current is very high.<sup>3</sup> The oldest of the wind tunnels of importance in the development of aviation is that of Eiffel,<sup>4</sup> and from it in 1909-10 came a number of experiments on wing forms at a time when flying-machines were becoming realities. The Eiffel type of wind tunnel has been used elsewhere and in France a new installation has been erected at St. Cyr.<sup>5</sup> The other European wind tunnels of note are in Italy (Rome), at Göttingen University (Germany) and Koutchino (Russia). Owing to the general upheaval in Russia the last-named laboratory is closed, but it earned distinction in the years of its activity particularly in dealing with interesting experiments on fundamental points in the theory and practice of the day.

In general conception all wind tunnels agree in attempting to obtain a uniformly distributed, non-fluctuating air stream; and the tendency has been to increase the dimensions and the velocity attained in passing from one installation to a succeeding type. Economy of power for a given extension of experimental range is, by the principles of dynamical similarity, more readily obtained with large dimensions than with high speed. The best criterion, other things being unchanged, is the product of diameter and velocity, and judged on this standard the largest installations of the various countries do not differ materially.

At the Royal Aircraft Establishment (formerly called the Royal Aircraft Factory), Farnborough, a speed of 100 m.p.h. (nearly 150 ft. per sec.) is reached in an air stream 7 ft. square. At the National Physical Laboratory a speed of 110 ft. can be produced in a stream 7 ft. deep by 14 ft. in width and forces on a model of the order of 200 lb. are there contemplated.

The larger Eiffel tunnel gives an air speed of 40 metres per second (150 ft. approximately) on a circular section about two metres in diameter. The tunnel at McCook field (America) gives the very high speed of 500 ft. to a circular stream of air about 3 ft. in diameter.

The experimental section of an Eiffel type wind tunnel consists of an air stream as it crosses an open room from wall to wall, through a specially devised nozzle and collector. The National Physical Laboratory type and others use a working section of the stream in the centre of a chute with solid walls. There are no striking advantages of either type so far as can be seen at the present time. The great desiderata are uniformity of distribution of velocity across the stream and freedom from large pulsations. Uniformity of distribution is almost automatically secured by using a straight air stream. Once curvature has been introduced by the turning of corners the difficulties of producing uniformity are formidable. On the other hand the delivery of large volumes of air—nearly half a million cub. ft. per minute in the large tunnels—requires special consideration if large eddies in the room with consequent pulsations in the flow are to be avoided. There is an opinion, supported as yet only by crude experiments, that the N.P.L. type of channel is somewhat less fluctuating than the Eiffel type. For the delicate adjustments required in the measurement of stability coefficients high value attaches to the steadiness of the air stream.

In dealing with efficient wing forms, where the lift may be more than 20 times the resistance, it is important that the direction of the air stream be accurately known and remain fixed; one-tenth of a degree is considered to be the maximum permissible error. It is found by experience that in a parallel walled channel the wind sets itself parallel to the walls with the accuracy desired. Freedom from large variations of velocity across the section depends not only on the straightness of the chute but also on the distance over which the air has been in contact with solid walls. From some experiments by Stanton it appears that the final distribution of velocity in tubes is not reached for some 20 to 50 diameters behind the open end. On the score of space required and power needed such proportions are unrealizable in wind channels and in other respects would be dis-

advantageous. Some variation of velocity distribution from point to point along a wind channel is then to be expected, there being a retardation of flow at the walls and an acceleration in the centre. This change of flow is accompanied by a fall of static pressure along the working section of the channel. For experiments on wings, struts, etc., these departures from uniformity are unimportant but in the case of long models of airship forms there is introduced a spurious resistance large in comparison with that proper to the airship model. It has been suggested, and experiments are being carried out to give effect to it, that the objectionable effects of the wind channel might be minimized by the substitution of a slightly diverging chute in the working section for the usual parallel part. It appears to be possible by such device to increase substantially the ease and accuracy of tests on airship forms.

The motion of the air in the wind tunnel is eddying and on this account a difference from motion through still air exists. So far, however, no suspicions have been aroused as to the inapplicability of model tests on this ground. Some eddies produced in the working of a tunnel are worthy of mention. If light sawdust be sprinkled over the floor of the building housing a wind tunnel, below the intake, it will be noticed that isolated miniature whirlwinds are produced. Some of these are vigorous and the base will clear a track amongst the sawdust whilst the core extends upwards to the tunnel intake. The spin in such eddies is great and the effect of the forces experienced by a body in the air flow is considerable. Being spasmodic, the effect is easily differentiated from that of the mean flow and an observer at an aerodynamic balance is conscious of a sharp blow on his apparatus. To eliminate these whirlwinds sufficiently a honeycomb is placed across the intake, the cells being small compared with the dimensions of the whirlwind. Some 10% to 20% of the energy of the power plant may be dissipated by the frictional resistance of the honeycomb and some appreciable length of tunnel is required to permit of the levelling-up of the flow before reaching the working section.

The design of a wind tunnel will be seen to involve much study if more than a very moderate degree of refinement of experiment be contemplated. The following brief description of a tunnel introducing modern knowledge may be of interest (see fig. 16).

The wind tunnel is housed in an unobstructed chamber a little longer than itself, a space of one and a half diameters between the intake and wall being sufficient for the satisfactory admission of air from the chamber to the tunnel. The cross section of the room should be 25 to 30 times that of the channel, otherwise the return flow of air from delivery to intake will produce fluctuations of undesirable large magnitude. The tunnel proper is straight and is placed symmetrically in the building, this being effective in securing symmetry of air flow in the working section. Taking the diameter of the section—whether square or circular—as a standard, the tunnel would have an overall length of 10 to 15 diameters made up of a parallel working section and intake four or five diameters long, having a rounded entrance and honeycomb, a cone connecting this working section to a circular race enclosing the aircrew, which may be of similar length, and a discharge section to the end of the room.

The aircrew giving steady flow is one of small pitch-diameter ratio but otherwise similar in characteristics to those used in aerial locomotion. The pitch-diameter ratio may be 0.4 upwards, the higher values giving rather greater economy of power and less steadiness. With careful design of aircrew and cone the divergences from channel to aircrew can be made large with resulting economy of power and no loss of steadiness.

The most modern method of dealing with the delivery stream is to divide the building into two parts by an openwork brick wall. Eddies in the return flow are thereby broken up to dimensions which do not greatly affect the steadiness of the air when it again enters the intake. In one instance, in addition to the partition wall, there is a structure closely surrounding the delivery from the aircrew; this delivery is in the form of a jet which impinges on the end wall of the building, and splashing over it, reaches the corners and forms rollers along the four walls. The structure over the jet is designed to break up the stream more completely than the porous wall alone. Instead of the free jet spreading at the wall it is distributed through holes in the covering structure, the spacing being such that equal volumes of air are delivered through each unit of area of the distributor. The number of openings per unit area is small near the wall of the building and increases to cover the whole area just before the aircrew section. It is possible to reduce the velocity at which the air returns to the room to 5% of that in the jet without the introduction of appreciable back pressure at the aircrew.

*Methods of Measurement of Velocity of Air.*—Having secured uniformity of distribution and a degree of steadiness sufficient for the type of experiment to be performed, it is necessary to be able to measure the air speed. No simple means is known of obtaining a standard of reference using a wind channel alone, and only one measure—possibly two—of absolute air speed appears to have been made under precision conditions. The particular measurements made on a whirling arm and in the William Froude National Tank at the National Physical Laboratory

<sup>1</sup> Report A. C. A., 1912-3. R and M, 68.

<sup>2</sup> Mass. Inst. of Technology.

<sup>3</sup> McCook Field.

<sup>4</sup> Eiffel, *La Résistance de l'air et l'Aviation* (Dimod & Pinet, 1910).

<sup>5</sup> *La Nature*, Oct. 2 1921.



gave a standard anemometer which is easily maintained and reproduced and which is accepted throughout the world.

The essential parts of the anemometer are an open-ended tube facing the air current and a parallel walled tube with its axis along the wind, the walls of the tube being perforated by small holes. The open-ended tube is usually referred to as a "pitot" tube, the name being that of one of the early users, whilst the perforated tube is designed to give what is called "static pressure." If the perforations of the static pressure tube be some six diameters behind the closed end it appears that all such tubes give the same reading, independently of size from a fraction of a millimetre upwards, and that the pressure inside the tube is the same as that on a body moving with the air stream. The pressure in the pitot tube is higher than that in the static-pressure tube and the difference, being due to the motion of the air and the stoppage of a central stream by the pitot tube, is usually referred to as "dynamic pressure" or "pitot head." The size of the pitot tube is unimportant and there is little difficulty in reproducing the standard tubes so that they agree with each other within a fraction of 1%. This represents generally the order of accuracy of aerodynamic measurements, but for certain simple comparisons of force and speed an accuracy of 1/2% is attainable.

The experiments on the whirling arm at the National Physical Laboratory showed that the dynamic pressure of the anemometer was proportional to the square of the speed through the air. On physical grounds it is known that the dynamic pressure is also proportional to the density of the air. So long as the compressibility of the air does not enter into the effects of motion, the constant of proportionality is found to be equal to one-half, with a probable error of the order of 1/10%. The extreme range of speed was from a few in. per sec. to 50 ft. per second. On the principles of dynamical similarity, to be explained later, experiments at a speed of 20 ft. per sec. in water can be used to give information as to what happens at a speed of 250 ft. per sec. in air. Using the William Froude National Tank for the purpose, the dynamic pressure of the "pitot-static" tube anemometer has been calibrated to within 1% up to speeds of 250 ft. per sec. in air.

Over the whole of this range the formula for dynamic pressure given by

$$p = \frac{1}{2} \rho v^2 \left( 1 + \frac{v^2}{a^2} \right) \quad (1)$$

is an accurate representation of observations on the pitot tube anemometer. In this formula,  $p$  is the pressure in force per unit area,  $\rho$  the mass of unit volume,  $v$  the velocity of the air past the pitot and  $a$  the velocity of sound in undisturbed air at the place. So long as all the quantities are measured in a self-consistent set of dynamical units the equation is satisfied. The second term in the bracket will be seen to be small in comparison with the first up to speeds of 200 ft. per second. The velocity of sound being a little more than 1,000 ft. per second it will be seen that the second term is less than 1% of the first within the range considered. This 1% is a measure of the effect of the compressibility of air and illustrates a general rule—that, for the purposes of aeronautics, air may be considered as an incompressible fluid. The statement is far from true as applied to the motion of a shell fired at usual velocities and may need modification in aeronautics when applied to aircrews. In ordinary practice the tip speed of an aircrew is upwards of 600 ft. per sec. and a few experimental forms have been made to reach tip speeds of 1,200 ft. per second. In the former case the effects of compressibility have not yet been disentangled from other effects, whilst in the latter some preliminary observations show marked changes of type of flow as a result of high speed and the introduction of modifications due to compressibility of the air.

**Dynamical Similarity.**—The understanding of the laws of air motion in aeronautics and gunnery has been greatly assisted by the theory of dynamical similarity. An early formula was given by Lord Rayleigh<sup>1</sup> and had a marked influence on progress, not only in Britain but abroad. In the later publications of the Advisory Committee for Aeronautics numerous references are made to aeronautical applications of the principle.

All the world is familiar with the idea of similarity in some form or other and there is little difficulty in appreciating the statement that human beings are similar to each other or, more accurately, are nearly similar; the horse would not be included so readily in the category of animals similar to man. The idea of dynamic similarity extends to motions what is more usually applied only to concrete bodies. Motions may be exactly similar, nearly similar, or very different, and in the case of an invisible fluid like air the eye is no guide to comparison. It is true that air may be coloured by smoke and the motion followed and that some work has been carried out on such basis. When it is found, however, that the fluid may be changed without loss of essential characteristics of the motion, a new line of attack is opened and

<sup>1</sup> Advisory Committee for Aeronautics, 1909-10, p. 36.

the study of the motion of water or any other fluid will give the essential information. A striking experimental investigation of the reality of the law of equivalence in certain cases was made at the National Physical Laboratory. The motion of air past a square plate was observed and photographed.<sup>2</sup> Smoke admitted to the current showed fluid impinging on the plate and spreading in the water. At a very low speed it was easy to detect a winding of the air round two axes roughly in the direction of the stream. A section of the stream across these axes would have shown particles moving in spirals winding inwards. This was a permanent state. At a higher speed a very noticeable change occurred in the type of motion. Instead of the spirals retaining a steady position, the smoke showed instability had occurred, and periodically loops formed across the two axes, broke away and travelled down stream. It is known by the principles of dynamical similarity that it is possible to produce similar flow in water. Exact conditions for the second experiment follow from those of the first. Further photographs<sup>3</sup> show that the comparison of types of flow is exact within the limits of observation. Neither of the motions described is calculable and the principle of dynamical similarity offers no assistance to understanding why an eddy occurs or what its type will be. It says, quite definitely, that if a given type of motion, eddying or otherwise, exists under certain circumstances, there are sometimes a great number of other circumstances in which the same type of motion must occur, and it lays down in precise terms the other circumstances in their relation to the given type. The instance given above related to change of fluid; other changes might be those of velocity or size. Clearly the change of size covers the relation between model and full scale.

The applications of dynamics to similarity depend on fundamental theories. The common ground exists in Newton's laws of motion but superimposed on this common ground are a number of special cases. In investigating the motion of fluids at ordinary velocities, physicists have identified the property of viscosity; at high velocities compressibility matters and so on. The physical properties of fluids and the quantities involved in motion are expressed in terms of numerical factors and dimensions, e.g. 10 ft. per sec. means a velocity of a certain magnitude, the numerical factor 10 and the dimensions ft. and sec. being necessary to give full meaning to the idea of the particular velocity. If a complete dynamical equation be written down it must, if true, satisfy the condition that the numerical values of the two sides of the equation are equal and that, independently, the dimensions are equal. The latter point may be sufficient to give useful mathematical form to the physical ideas. For example, imagine an aeroplane to be gliding down through still air at some known speed. The resistance or drag will depend on its shape and size, its speed, the density of the air and the viscosity of the air. For the moment it will be assumed that the drag is dependent only on the quantities enumerated.

Force has the dimensions  $\frac{ML}{T^2}$  where  $M$  is the symbol for mass,  $L$

for length and  $T$  for time. Velocity,  $v$ , is represented by  $\frac{L}{T}$ , density by  $\frac{M}{L^3}$  and viscosity by  $\frac{L^2}{T}$ . (See footnote 4)

Expressed in the form of an equation the assumptions so far made amount to

$$R = f(\rho, l, v, \nu) \quad (2)$$

where  $R$  is the resistance,  $l$  a typical linear dimension of the body and  $f$  a functional form which depends on the shape of the body. It is common to include in  $f$  the presentation of the body to the wind as well as its shape, but this can be excluded at will by introducing angular coordinates into the arguments of the function. The principle of dynamical similarity states that  $f$  may only have such a form as will make the dimensions of the two sides of (2) agree. For methods of finding the most general expression for  $f$ , consistent with dimensions, reference may be made to textbooks, etc.; it is found that (2) cannot have a more general form than

$$R = \rho F v^2 \left( \frac{\nu}{v l} \right) \quad (3)$$

<sup>2</sup> Advisory Committee for Aeronautics, and Applied Aerodynamics, L. Bairdrow.

<sup>3</sup> *Ibid.*

<sup>4</sup> The coefficient of viscosity used in dynamics is denoted by  $\nu$  and referred to as the "kinematic coefficient of viscosity." The other common coefficient  $\mu$  is related to  $\nu$  by the equation  $\mu = \rho \nu$ .

<sup>5</sup> Applied Aerodynamics, L. Bairdrow, p. 38a.

No dynamical equation depending on the quantities mentioned earlier can exist which is not included in (3). For the purposes of comparison of resistances it has been found convenient by the aerodynamical laboratories to tabulate the value of  $F \frac{v^2 l}{\rho}$  for various bodies and to use the symbol  $k_b$  for it. Equation (3) may then be written alternatively as

$$F \left( \frac{v^2 l}{\rho} \right) = k_b = \frac{R}{\rho v^2 l} \quad (4)$$

and in this form several points of importance are evident. To make the case specific, consider the resistance of a sphere in air as obtained from a wind-tunnel measurement. If the dimension  $l$  be identified with the diameter  $d$  of the sphere it will be noted that  $\frac{R}{\rho v^2 d}$  is an experimentally determinate quantity and from it values of  $k_b$  are determined. An examination of the dimensions of  $k_b$  will indicate that they are zero; the coefficient is therefore a pure number and so of international validity. Another method of statement would be to say that the numerical value of  $k_b$  is independent of the system of units used so long as the system is self-consistent. Measurements of force may be made in dynes, mass in grammes, lengths in centimetres and time in secs. to meet the standards of the physicist. Alternatively the engineer may use the force unit of lb. weight, the slug as a unit of mass, the foot for length and the sec. for time, or, if he prefers it, the force unit of poundal, the mass unit of pound, and the foot and second. In all cases the tabulated values of  $k_b$  would be identical. There are further advantages of the system;  $k_b$  is independent of the air density and for most aeronautical purposes almost independent of size and speed, so that comparison between model and full scale is readily made by comparison of the corresponding values of  $k_b$ . The extent to which the two agree is a measure of the utility of experiments on models.

Equation (4) also shows that  $k_b$  depends on a single variable  $\frac{v l}{\nu}$ , not separately on  $v$ ,  $l$  or  $\nu$ . On theoretical grounds alone therefore we may say—for our special assumptions—that  $k_b$  will not change if the velocity of the same body be doubled in a fluid having twice the viscosity. The kinematic viscosity of air is 12 or 13 times that of water at ordinary temperatures and hence the resistance coefficient will be the same if the velocity of air be 12 or 13 times that of water. Stanton has shown that this is true for smooth and rough pipes by testing with the two fluids in the same apparatus.<sup>1</sup> The law was used in the calibration of the pitot-static pressure tube.

$\frac{v l}{\nu}$  may be kept constant in many other ways; if air be the fluid used in two experiments, then  $v$  and  $l$  may vary so long as the product is constant. A model aeroplane to one-tenth scale would give a resistance coefficient on test equal to that on the aeroplane at one-tenth the speed. Since the speeds of flight reach 200 ft. per sec. this law is inapplicable to the complete aeroplane, for compressibility of the air would be very important in the model test at 2,000 ft. per second. In testing stream-line struts or wires, it is easily possible to make models larger than the reality and so to extend the equivalent speed from that of the wind tunnel to that of flight.

It should be noted, however, that failure to satisfy the law of corresponding speeds, i.e.,  $v l = \text{constant}$ , does not necessarily imply failure to obtain similarity of flow between model and full scale. In most of the experiments known to us, resistance varies very closely as the square of the speed and the hypothesis that an exact law existed is worth examination.

Since  $R$  varies as  $v^2$  it follows from (4) that  $k_b$  is independent of  $v$  and further that  $k_b$  must then be a constant for all values of  $\frac{v l}{\nu}$ .

In such a case the law of corresponding speeds is of no importance, for  $k_b$  can be deduced from a test at any speed on any size of body. It needs little effort to see that if  $R$  varies a little from proportionality to  $v^2$  the motions in model and full scale will be nearly similar and that the function  $\frac{v l}{\nu}$  is relatively unimportant. It is on this variation from strict theory that aeronautics depends in many applications of model results. Since there is no absolute theoretical sanction except in the case of corresponding speeds, the identity of the values of  $k_b$  on the model and full scale must be tried out in a sufficiently large number of typical cases if reliability is to be established. This has in effect been done for aeroplane wings.

It is exceedingly difficult to determine from flight experiments the resistance of the wings of an aeroplane, for the flying apparatus must be complete with body, undercarriage, aircrew and engine, all of which materially affect the resistance of an aeroplane. The comparison of the pressures at chosen points on an aeroplane wing in flight and on a model of it in a wind tunnel is far less difficult and has been made.<sup>2</sup> The theory which led to equation (4) leads also to the conclusion that the pressure divided by air density and square of

speed is a function only of  $\frac{v l}{\nu}$ . Special photographic anemometers<sup>3</sup> were made by the Royal Aircraft Establishment for use in flight and the pressures over a section of the upper and lower wings of a biplane were measured.

The types of variation of pressure on the full scale are faithfully reproduced by the model and in three of the four comparisons the actual numerical agreement is complete within the accuracy of measurement. The difference on the fourth comparison has not been explained and some doubt exists as to its reality. Repetition of the experiments has not yet been made. Generally, however, it is clear that in heavier-than-air craft the use of models is amply justified. For airships the lack of full-scale experiment precludes any statement of value.

In the course of the investigations of the variations of  $k_b$  with speed and size it was found that changes of appreciable magnitude occurred at the lower speeds of wind tunnels but that the values tended to a limit. It is the value of  $k_b$  at the limit of opacity of wind tunnels which is taken in default of correcting factors determined from a comparison between full-scale and model experiments. On the score of cost it is not practicable to increase the size of wind channel or the speed of the wind indefinitely and the highest value of  $v l$  appears to be obtained most economically by large size rather than high speed. There are some other advantages of size; the completeness of detail possible increases with the size of model and one of the claims in favour of the large 7 ft. x 14 ft. channel at the National Physical Laboratory is that the model will be so large that an air-crew can be fitted to it and the combination of aircrew and aeroplane tested under conditions very closely resembling those in flight.

*The Effect of Compressibility on the Motion of Air.*—The law of corresponding speeds expressed by the relation  $\frac{v l}{\nu} = \text{constant}$  is peculiar to the assumptions made in obtaining (4) as to the experimental factors which have appreciable effects on resistance. There is an indefinitely large number of laws of corresponding speeds, each law being applicable under limited conditions. The method of finding the appropriate law is clear; the process begins with a statement of the physical quantities and measurements involved and concludes when an equation of the correct dimensions has been found. The conditions may be so complex that the answer, when obtained, is of little value; in general the theory of dynamical similarity is useful only when the number of important variables is less than five.

The difficulty here indicated can be seen, if, instead of limiting the problem to a fluid characterized by density and viscosity only, an extra property defining its compressibility is included. There are various ways of expressing compressibility and the most obvious would be through an elasticity modulus. Density is included already in the properties considered, and the velocity of sound in a fluid is determined by the ratio of the modulus of elasticity to the density. It has then come to be usual to assume that the velocity of sound  $a$  is a convenient variable when investigating the effects of compressibility of a fluid on the resistance to the motion of a body through it.

The equivalent to equation (2) for the extended problem is

$$R = f(\rho, l, v, \nu, a) \quad (5)$$

and restricting the form of  $f$  to that which satisfies the theory of dimensions

$$\frac{R}{\rho v^2 l} = k_b = F_1 \left( \frac{v l}{\nu}, \frac{v}{a} \right) \quad (6)$$

To satisfy the theoretical conditions which guarantee the constancy of  $k_b$  it is necessary to satisfy simultaneously the equations

$$\frac{v l}{\nu} = \text{constant}, \quad \frac{v}{a} = \text{constant}$$

for such variations of size, speed and fluid as are at disposal. Once the fluid is specified,  $\nu$  and  $a$  are given and no law of corresponding speeds exists. Various proposals have been made to use a gas such as carbonic acid in one experiment and air in another, but little use appears to have been made of (6) in the form given.

The formula for the pressure due to a pitot tube anemometer—(1)—is a particular case of (6). That the form of (1) agrees with (6) can be seen by an expansion of the functional operator of the latter in powers of  $\frac{v}{a}$ , using Maclaurin's theorem. Such an expansion will be useful so long as the effect of compressibility is small and the argument  $\frac{v}{a}$  small. There is a further simplification in the case of the pitot tube since the resistance does not depend measurably on  $\frac{v l}{\nu}$ . From experiments on the issue of steam from the nozzles of turbines and the measurements of pressure on a shell in flight it appears that in many cases

$$\frac{R}{\rho v^2 l} = F_2 \left( \frac{v}{a} \right) \quad (7)$$

is a type of formula applicable to the maximum possible pressure on a moving body for speeds ranging from a few in. per sec. to 2,000 ft. per sec. and upwards.

<sup>1</sup> Advisory Committee for Aeronautics, 1911-2, p. 41.  
<sup>2</sup> Report, Scale Effect Sub-Committee, A.C.A., 1917-8, R and M, No. 374.

<sup>3</sup> Report, A.C.A., R and M, No. 287, p. 504, 1916-7.



It is possible that a correcting factor will be introduced into the design of airscrews to allow for compressibility of the air. In such a case, resistance coefficients based on (7) would provide the first approximation to a rational formula.

**Tests of the Water Resistance of Flying-Boat Hulls.**—Applications of dynamical similarity extend over the whole range of physics and an exhaustive discussion would lead far away from aeronautics. One other illustration is required to show the origin of the law of corresponding speeds applied in naval architecture to surface-moving craft. Experimentally it has been found that the resistance of surface craft at high speeds depends greatly on the generation of waves. If attention be concentrated on this new aspect of resistance it will be found—by methods already indicated—to give the law of corresponding speeds associated with the name of Froude.

At any point of a wetted surface the pressure is proportional to the head of water above that point and will be increased if a wave crest exists in the neighbourhood. The pressure depends on the head and on the weight of unit volume of the water; alternatively the weight may be expressed as the product of the density of the water and the acceleration due to gravity. Now consider the problem of similar motions between a ship and a model of it. The scale of the model must apply to the scale of the waves if similarity is to exist. It can be said therefore that the resistance depends on a linear dimension  $l$ , velocity of test  $v$ , density of water  $\rho$  and the acceleration due to gravity  $g$ . The appropriate formula then follows and proves to be

$$R = \rho v^2 F_s \left( \frac{v}{lg} \right) \quad (8)$$

The law of corresponding speeds is therefore  $\frac{v}{lg} = \text{constant}$ .

When dealing with comparisons of motion on the earth's surface,  $g$  is constant and the law states that the speed of test for the model varies as the square root of the scale. This condition ensures that the waves in model and full-scale trials shall be similar. Equation (8) may apply in other cases, such as the disturbed motion of model and actual aeroplanes in free flight, the governing factor being the dependence of the motion on gravitational attraction.

**Summary of the Aeronautical Uses of Dynamical Similarity.**—In measurements of resistance to the motion of a body through viscous fluid the correct law of corresponding speeds is that  $\frac{v}{\nu} = \text{constant}$ ; this is applicable so long as the velocity of motion is not more than about one-quarter that of sound. At higher velocities, compressibility of the fluid modifies the flow, the changes depending on a further factor  $\frac{v}{a}$ , i.e. on the ratio of the velocity of the body through the fluid to that of sound in the fluid.

If the wave-making resistance alone be considered the law of corresponding speeds for terrestrial surface craft is  $\frac{v}{\sqrt{g}} = \text{constant}$ ; where resistance depends partly on wave-making and partly on viscosity it is generally assumed that the two can be treated by special assumptions. A very accurate method of treatment of the complex problem does not lead to practicable formulae.

**The Resistances of Bodies of Various Shapes.**—A somewhat sharp division exists between the resistances of wings and aerofoils and those other bodies with which aeronautics is concerned. In the latter cases the resultant air force is either directly opposed to the motion or is little inclined to it. In the case of wings at the most efficient angle of presentation the resultant force is almost normal to the direction of motion. Since there is always a real drag the direction of the resultant force must fall behind the normal but the amount may be less than three degrees.

It has been found experimentally that all aeroplane wings—whatever their variations of shape—have certain common characteristics. The best ratio of lift to drag is obtained only at a particular angle of attack of the wing to the air and a considerable loss of efficiency is incurred if, as is usual in aeroplanes, departure from this



FIG. 17a.—Flow past wing  
6°. Below critical angle.

angle to the extent of 5° or 6° be permitted. At the highest speed of flight of the aeroplane of 1921 it is improbable that the lift exceeds 12 times the drag, whilst the maximum ratio exceeds twenty.

Apart from efficiency there is a limit to the greatest force which can be obtained at a given speed by a wing of finite area. Omitting very special complex wings for the moment, the limiting force at any given speed is obtained when the wing is inclined at 15° or 20° to the wind. One of the most efficient types of wing form for high-speed



FIG. 17b.—Flow past wing.  
20°. Below critical angle.

flight has a limiting lift of about 7 lb. per sq. ft. at a speed of 50 m.p.h. Other forms of fixed section are known which give 12 lb. per sq. ft. at the same speed. The general experience of all experimenters with aerofoils has been that, so long as the shape of the section is invariable, high loading at the angle of maximum lift cannot be obtained at the same time as high efficiency for maximum speed.

Much attention has been paid therefore to flexible and variable wings; if it were possible to vary the area of a wing at will without introducing unreliable mechanism or adding greatly to the weight of the wing structure that solution would offer the maximum aerodynamic advantages. It should be pointed out here, that the addition of weight to an aeroplane in such a place as not to add directly to the resistance leads to an immediate and calculable indirect increase of resistance at a given angle of incidence; the amount may be estimated as about one-eighth of the weight under favourable conditions. So far no satisfactory proposals exist for the mechanical variation of the area of the wings of an aeroplane. More practical success has met the endeavours to vary the section of a wing of given size so as to obtain the advantages of high lift and consequent low speed for alighting and high efficiency at flying speeds. It has already been shown that either condition may be obtained by a wing of fixed section. A further general observation is that the high-speed wing is thin and flat whilst the high-lift wing is thick and greatly curved. Means of constructing flexible ribs for wings to admit of continuous change from one shape to another have been developed and the mechanical difficulties do not appear to be insuperable. A less obvious method of attack has shown greater promise. Mr. Handley Page<sup>1</sup> found by experiments in a wind tunnel that the properties of high lift could be obtained by allowing air to pass through the front part of a wing from the lower to the upper side. By dividing the wing of an aeroplane into a small aerofoil hinged at its leading edge and a large main wing the device becomes both mechanically and aerodynamically effective.

The motion of an aeroplane is now realized to be dominated by other considerations than those of lift and drag and it may be that a particular high-lift wing would be useless because it led to failure of lateral control at low speeds. This point is of growing importance and aeroplane design can no longer ignore the complex interactions of aerodynamic properties. For this reason it may be anticipated that the full advantages from variable wings will not be obtained immediately but that the processes of evolution will be followed. Past history has been simpler; early experiments by Langley<sup>2</sup> (1896) covered the properties of flat plates used as aerofoils and laid the general foundation of practical aviation. Lilienthal later showed that curved surfaces were more efficient than flat ones and attention was given to sections suggested by bird wings, a subject of interest still occupying the minds of designers. With little guidance as to good forms, the early pioneers of flight, Wilbur and Orville Wright, Farman, Blériot and others, introduced wing sections in the period 1906-10 and on these Eiffel based his first series of experiments.<sup>3</sup> Design then began to be regularized. One of the more promising wing sections examined by Eiffel in his wind tunnel at the Champs de Mars, designated "Blériot 11 bis," was adopted by the Royal Aircraft Factory for the BE2A. In 1911, the National Physical Laboratory adopted this form as the starting-point for systematic variation of wing form. In the series of experiments which followed,<sup>4</sup> the thickness of the wing was changed, also its shape on upper and lower surfaces and the bluntness of the nose, and in each case measurements of lift and drag were made. From this series it was possible to make a rational choice of wing section to fit the conditions of the day. The absolute maximum of aerodynamic efficiency demanded a wing too

<sup>1</sup> Jour. Royal Aeronautical Society, 1920.

<sup>2</sup> Résistance de l'air et l'Aviation, 1910-1.

<sup>3</sup> A.C.A., 1911-2, pp. 73-77.

thin for structural reasons and the Royal Aircraft in the early days of 1913 designed the RAF6 wing on the basis of these experiments for the development of the aeroplane BE2. At a later stage, as engines of greater power were produced, further experiments led to improvement of wings at small angles of incidence and RAF6 was replaced by RAF15 (May 1915). It was found that the advantages of the latter at high speeds were appreciable in spite of the increase of wing area necessary to maintain a reasonably low landing speed.

Many attempts have been made to introduce new wing forms and those showing value on preliminary test have been investigated. It has invariably been found that guesses have been inferior to the results of systematic investigation. In order to facilitate comparison all results of wing tests are—in Great Britain—reduced to a standard form. Different expressions are common in France and America but neither of the latter is international in the sense of being non-dimensional. In accordance with principles of dynamical similarity, the measured forces, lift and drag, have been divided by air density, wing area and sq. of speed in order to deduce lift and drag coefficients. A centre-of-pressure coefficient is obtained by expressing the position of the centre of pressure by the ratio of its distance from the leading edge to the chord of the wing. The results are usually shown in curves as well as tables and, if uniformity in scale be adopted for the curves, comparison of wings is greatly facilitated, since superposition immediately indicates the relative advantages and disadvantages.

It is clear to most workers in the subject that the angle of incidence of a wing is a convenient but arbitrary variable. A more useful relation than lift to angle of incidence and drag to angle of incidence is that of drag to lift, and it is very common to find in the records of the aerodynamics laboratories the value of drag coefficient plotted on a base of lift coefficient. The idea was in effect used by Eiffel in 1910 in a system of polar diagrams. When comparing wings for a given duty a still further variation is sometimes made; the area of a wing depends on the specified landing speed and on the maximum lift coefficient. Only when both these quantities are included can the criteria be of greatest value. If it be presumed that the condition of prescribed landing speed is to apply to an aeroplane with different wings it can be shown that at other speeds the lift coefficients of the respective wings will be proportional to the maximum lift coefficients. Hence a curve of drag coefficient on the ratio of lift coefficient to maximum lift coefficient has direct use.

Further elaborations have been used, one of which, due to the Royal Aircraft Factory in 1911, is equivalent to the plotting of horse-power on a basis of speed. A new point is thus brought into prominence for it is seen that the choice of wing form to meet given requirements is affected by the resistance of the rest of the aeroplane. Brief notes on the character of this additional resistance will be made at this point.

The aeroplane as a whole is made up from various parts: wings for support; body for holding the engine, pilot, load and control organs, and the undercarriage for leaving the ground and alighting. The same organs are required by float seaplanes and amphibians but in the boat-type seaplanes the body and alighting gear are combined into one structure. The wings themselves are usually supported by struts and wiring which add to the resistance and there is a disposition to test and fit wings which are designed to be strong enough to support the weight of an aeroplane without external bracing wires. It is desirable here to emphasize the fact that the result may not be an effective reduction of resistance owing to the less advantageous types of wing section which must be used and to the greater mechanical difficulties of construction.

The resistances of the body and undercarriage are easily appreciated; both vary very closely as to the square root of the speed and are scarcely changed by alteration of the angle of incidence of the aeroplane. At high speeds the added resistance is roughly equal to that of the wings whilst for the most efficient flight the proportion is more nearly 1 to 2, the wings having the greater resistance. There is a loss, due to the engine which is not quite so evident as that due to the body. If water-cooling be adopted, the engine may be totally enclosed and so have no direct effect on the air flow, but in order to maintain the cooling, radiators in the wind are required. It does not matter whether the engine be air-cooled or water-cooled, a certain minimum resistance to motion must be incurred to provide the cooling. Experiments have indicated a relationship between the heat dissipated from a hot surface and the skin friction given by the motion of a fluid over that surface, and the best known radiator is the honeycomb type. Disturbance of the air by a cooling surface which is such that the motion is violently eddying involves a higher resistance for a given dissipation of heat.

The placing of the radiator in the wind near the aeroplane may have important secondary effects. The body is made to approach a streamline form as closely as possible in order to reduce its resistance and the approach to the best results is found to depend greatly on the choice of shape. The magnitude of the possible effects of shape on resistance is most clearly shown by experiments on airship forms. The resistance of an airship envelope is only from 1% to 2% of that of a disc which would cover the section at the maximum diameter. It is true that the aeroplane body is far removed from this condition

but it is still sufficiently fine to have its resistance increased by an unsuitable disposition of radiator. There is little systematic knowledge as to the best arrangement, and the problem of engine-cooling and body form remains one of engineering difficulty and uncertainty.

**Performance of Aeroplanes.**—Rapid development—also costly,—was facilitated by the construction and test of numerous aeroplanes for war purposes. Not until 1917 did the measurement of engine power and aeroplane performance in Britain reach the stage of generality and accuracy necessary for the purposes of estimate and prediction. Other countries entered the field at still later dates and it will be seen that aviation is still in early infancy. Progress is now less rapid, the main aerodynamic features having been brought to a state at which, the work of all the better designers produces nearly the same result. So true is this statement that curves can be drawn relating engine power to speed of flight, rate of climb and total weight curves which show what a designer can attain but rarely exceed. The greatest changes in 1917–21 were in the power plant and here limits are becoming clearly discernible. The changes in the weight of the aeroplane structure due to more advantageous use of material were also small, and in all directions new advance can only be won by assiduous study. The period of striking progress is over and has given place to one in which greater training and knowledge are required than in the past. This is particularly true in matters relating to the reliability and safety of aircraft.

**Stability.**—The idea of stability as applied to motion is very old and standard methods of dealing with mechanical problems were gradually developed by the mathematicians of the last century. Laplace applied his knowledge to an examination of the stability of the solar system, i.e. he accepted the theory of gravitation as accounting for observations and made an extension to see whether the motion was permanent or in a state of change. The ideas of stability are quite different from those of performance and at the present day it is safe to say are not understood by designers with the degree of intimacy which leads to incorporation in design. It is true that some rough generalizations exist and are acted upon; by placing the centre of gravity of an aeroplane very far forward longitudinal stability is ensured whilst a rearward position tends to instability and danger. Similarly, the fin's dihedral angle on the wing is known to affect lateral stability. Present-day (1921) aeroplanes border on neutral stability for the conditions of straight forward flight and this has come about by trial and error, corrected by the likes and dislikes of a pilot during aerial fighting. So long as the pilot be alert and the aeroplane of moderate size, say less than 6,000 lb. weight, it is possible to control the craft in the air in the condition in which it leaves the works. The few attempts to make very large aeroplanes, 20,000 to 30,000 lb. in weight, have led to early disaster owing to the inability to approach, on such scale, the necessary degree of refinement of control and stability. Alternatively it may be said that the attempt to develop large aircraft has overstepped the reasonable limits of caution and has placed on the pilot a strain which he is physically incapable of withstanding.

Even in the smaller craft there are many which in normal flight require the unremitting attention of the pilot and which if left to themselves for a minute would be in a dangerous and probably uncontrollable condition of flight. This is not a necessary state for an aeroplane and there is no insuperable difficulty, given training, in ensuring, without an appeal to trial in the air, that an aeroplane will fly itself for long periods. The opinion has been expressed that aircraft of the present day would be of commercial value were the obviously removable defects dealt with. Reliability of the engine installation is probably the most urgent need, but following that comes the application of the known theories of stability.

Broadly speaking the quality called stability is readily defined. An aeroplane is taken into the air and a given state of motion produced by the pilot and maintained for some time. This operation does not involve stability but requires adequate control. When flying steadily suppose that the pilot ceases

<sup>1</sup> See *Flight*, Jan. 13 1912, "An Aeroplane Study," M. O'Gorman.

to operate but keeps his muscles rigid and without disturbing the motion deliberately produces a condition in which the aeroplane has to control itself in gusts of small size. If the motion be stable, no great changes will occur as a result of the pilot's relinquishing of control. A small amount of pitching, rolling, yawing and side-slipping, etc., will occur but on the whole the speed of flight and the angle of incidence will remain at the same value as at the beginning; the wings will not change their angle of bank greatly nor the turning increase or decrease.

An instability, and in contradistinction to stability there are many instabilities possible, will magnify the effects of a gust with greater or less rapidity and the motion will depart from the initial state to some other stable state. It rarely happens that this second state is a comfortable one. An aeroplane which is unstable in normal flight will usually be stable upside down and may be so stable in that position as to be uncontrollable. The time taken to pass from one state to another is often only a matter of a few seconds, rarely as long as a few minutes.

In the very early days of flying the problem of getting into the air at all took first place in importance. The aviators of 1908-10 kept a very close watch on the weather and one of them had a standard test for satisfactory conditions. Standing with his feet apart, he dropped a feather from the level of his shoulders and if it fell outside his feet the wind was too great for flying. The record of these early years and the shortness of life of the aviators are sufficient testimony to the consequences of the extreme forms of instability. The revolutionary step which made it possible to keep the air for an hour instead of a few minutes was made by the Wright brothers when they introduced wing warping as a lateral control; there is little reason to doubt the statement that flying still remained an acrobatic feat. A study of the technical papers of the period 1908-14 will show how slowly the idea of banking<sup>1</sup> an aeroplane entered into the development of aviation. It is noted in March 1912 as a possible cause of accident that the pilot "is reported to have endeavoured to rise when making a turn." Not until April 1913 do we find vertical banking by Chevillard followed by upside-down flying and looping by Pégoud in Sept. of that year.

A prominent place in the technical journals was devoted to accidents and a perusal of these shows that all types were liable to fail as late as 1913. A series of accidents to monoplanes occurred in Britain and their flight was suppressed temporarily in Sept. 1912, whilst a committee was formed to investigate causes and to suggest lines of development. The findings of this committee<sup>2</sup> have had a marked influence on British aviation and the paragraph relating to stability is here quoted:—

"The Committee desire to urge the importance of the general investigation into the stability of aeroplanes, whether monoplanes or biplanes. The experimental data at present available are not sufficient to allow a complete theory to be formulated. It is understood, however, that the work of the Advisory Committee has now been carried to the stage at which the problem can be attacked with hope of success, provided that the necessary facilities—a large wind channel in a sufficiently big enclosed space—be put at their disposal, and the Committee recommend that the Advisory Committee be asked to continue the further investigation into the stability of the aeroplane as a matter of great urgency, and more especially to examine the question of inherent lateral stability, suggestions towards the solution of which have been given by the experiments of Lanchester and the calculations of Bryan."

The investigation here started led directly to the stability experiments on RE1 and BE2, a combination of full-scale flights at the Royal Aircraft Factory and model and theoretical preparatory work at the National Physical Laboratory. Before dealing with the results, a return to early times will be made to indicate the position of the theory of stability.

Up to the end of 1909 the chief writers on the stability of the aeroplane were Bryan,<sup>3</sup> Ferber,<sup>4</sup> Lanchester,<sup>5</sup> and Soreau.<sup>6</sup>

<sup>1</sup> *Flight*, Feb. 17 1912.

<sup>2</sup> *Report of Dpt. Comm. on Accidents to Monoplanes, 1912* (ed. 6506), p. 9.

<sup>3</sup> Bryan and Williams. "The Longitudinal Stability of Aerial Gliders." *Proc. R. S.* vol. lxxiii., 1904, p. 100.

<sup>4</sup> *L'Aéronautique*. A *Aérodynamique*, Lanchester.

<sup>5</sup> *Société des Ingénieurs Civils de France*, and in a volume: "État actuel et avenir de l'aviation."

The most complete method was that by Bryan. The papers all advanced the study of the subject in some measure but the appearance in 1911 of Bryan's book *Stability in Aviation* laid the foundations of the subject as now known to us. About the same time other workers were entering the field, amongst whom may be mentioned Knoller,<sup>7</sup> Bothezat<sup>8</sup> and Reiszner.<sup>9</sup> From that time the theory of stability has been far ahead of practice. Developments have been made to cover circling flight, disturbed motion and the effects of gusts, but all are natural extensions of the theory of dynamical stability as given by Routh and applied by Bryan to the aeroplane. There is little doubt that further extensions will be made as required, but the immediate need is the devotion of existing knowledge to practice to a far greater extent than has hitherto occurred. As in other branches of research the World War has had an adverse effect in curtailing opportunities for reasoned progress.

In March 1913 a report<sup>10</sup> was issued showing the possible applications of the theory of stability in numerical detail. The mathematical analysis cannot be useful unless a number of quantities, known as resistance derivatives, can be obtained from experiment. The report in question represents the first systematic attempt to apply experimental research to the evaluation of the quantities required for application of the theory. A discussion is given of the meaning and origin, from the physical side, of the resistance derivatives and rough estimates were made as to the ranges of the quantities for then existing aeroplanes. For one condition of flight more accurate data were obtained and a table of some 18 derivatives deduced covering the longitudinal and lateral stabilities of an aeroplane in normal flight. There are a number of approximations which assist in the understanding of the relation between cause and effect which were of importance in the infancy of the subject.

By such a preliminary examination on the model scale, the phenomena to be looked for on the full scale were clearly defined. The now well-known "phugoid" oscillation was then unobserved and only indicated by calculations. It is indeed possible that up to that date longitudinal stability did not exist apart from the very special design of Dunne. The mathematical theory indicated quite clearly that special shapes were unnecessary and that aeroplanes of more usual form could be made stable by attention to the disposition of weights and the arrangements of the aerofoil surfaces. In particular, the importance of a dihedral angle on the wings and an adequate fin and rudder were shown in relation to lateral stability.

In the course of the 12 months which followed great progress was made: in a series of papers<sup>11</sup> from the National Physical Laboratory, the effect of varying essential quantities, such as the centre of gravity of the aeroplane, the amount of area of the tail plane, the extent of the dihedral angle, rudder and fin area, etc., was examined in detail. It was shown that partial experiments on lateral stability would fail since there is a relation between the dihedral angle on the wings and the appropriate fin and rudder area.

Further, the exact method of inherent adjustment of an aeroplane to gusts was shown and the details of flight of a longitudinally stable aeroplane in a natural wind obtained. This was done not only for uncontrolled but for controlled flight. By the summer of 1914 the investigation of the effect of natural properties of an aeroplane on mechanical devices for controlling it were being envisaged, but the outbreak of the war broke the continuity and the subject still remains at that point of theoretical development.

In the meantime full-scale experiments were being made at the Royal Aircraft Factory.<sup>12</sup> A few extracts from these reports are of historical value and are here reproduced:—

"Although completely controllable under all circumstances by means of the elevator, it has been found that the BE2A aeroplane, fitted with the old tail plane (TP1) was not stable with the elevator free or even locked. . . . Two methods of experimenting have been adopted:—(a) Variation of the section and plane form of tail. (b) Variation of the position of the centre of gravity of the aeroplanes relative to the position of the wings."

"Experiment (1) with tail (TP1). Area of tail 61 sq. feet. Centre of gravity at 0.38 of the mean chord behind the leading edge. At a height of about 2,000 ft. the elevator control lever was held in a fixed position. After a short time, a steady dive developed, which was allowed to continue so long as it was considered safe by the flier, in this instance during a flight of about 500 yards. There was no tendency for the path to revert to the horizontal. It was found that there was just as much tendency for a steady rearing to be developed as a dive. . . ."

<sup>7</sup> "Über Langstabilität der Drachenflugzeuge." *Ztschr. für Flugtechnik und Motorluftschiffahrt*, July and Aug. 1911.

<sup>8</sup> *Étude de la Stabilité des aéroplanes* (Dunod & Plet. 1911).

<sup>9</sup> *Ztschr. für Flugtechnik und Motorluftschiffahrt*, Feb. 10 1912.

<sup>10</sup> R and M, No. 77, Advisory Committee for Aeronautics, 1913-4.

<sup>11</sup> *Reports, Advisory Committee for Aeronautics, 1913-4*, pp. 216-286.

<sup>12</sup> *Reports, Advisory Committee for Aeronautics, 1913-4*, pp. 385-394.

"Experiment (2). Another tail was tried (TP2). A long glide was also made with the elevator locked. During these flights a marked improvement in the behaviour of the machine was obtained, damped phugoids being described. . . . It may certainly be said, however, that with TP2 and the other conditions of this experiment, BE2 was proved to be capable of flying indefinitely with the elevator locked in winds with gusts up to 30 m. per hour.

"Experiment (3). The same tail plane was fitted and the conditions were approximately the same except that the centre of gravity was considerably further back. . . . This very backward position of the centre of gravity, of course, made the aeroplane quite unstable, and increasing dives or rearings were performed almost as soon as the elevator was locked.

"Experiment (4). The centre of gravity was brought forward and a considerable improvement was obtained. . . . It was now found that even with the elevator free, damped phugoids were obtained. In the absence of gusts at the time, these phugoids were started by movements of the elevator control lever. When the machine had been forced to assume a sharp dive, the control lever was totally released and it was found that after two or three complete oscillations the amplitude became too small to be noticed. . . . The period of oscillations was found to be about 20 seconds."

"Apart from the practical utility of these experiments in developing the particular aeroplane in question their wider significance underlies the fact that they agree with and confirm the model experiments on the full scale both as regards the characteristics of the tail planes and the interference of the main planes with them; and the two sets of experiments give data from which a tail can be designed for any aeroplane to give any degree of longitudinal stability required."

"It appears from recent investigation of accidents that the type of instability described above is not avoided in all modern aircraft. The effect of the instability is serious and epidemic failures to control have been traced to this cause alone.<sup>1</sup> Some photographic records of longitudinal motion taken at a much later period will be found as reproductions in the Wilbur Wright lecture<sup>2</sup> for 1919. The actual time required for the testing of longitudinal stability is now so short that the production of records has been made an addition to the older established performance trials. Progress has been steady but rather slow and the influence of the tests is not yet evident in new design."

"In the case of lateral stability the records of the early experiments at the Royal Aircraft Factory are of equal or greater interest with those on longitudinal motion—

RE1 rolling stability experiments, by Mr. Bush. . . . The wing flap controls were entirely abandoned and the aeroplane was flown 1/2 m. with two turns without their use. The rudder was used for steering or was kept straight to avoid complicating the investigation."

"The evolutions of the aeroplane bore out the theoretical expectations. Disturbance by a gust was followed by side-slip towards the low side, which brought the dihedral angle into effect, righting the machine. In both the above experiments the recovery from a roll seemed rather slow, and it was decided to double the amount by which the wings were bent up."

"The results of the above experiments were sufficiently satisfactory to warrant the abandonment of the warp and the use of wings with flaps for RE5 and other aeroplanes in course of design."

"Rotative Stability.—The rotative stability with the rudder in a fixed position was next examined. Up to this point the aeroplane had been usually steered on a straight course, which made recovery quicker. When the rudder is fixed, however, disturbance of level is followed by a turn towards the low side as well as a side-slip. If the directional stability is too great, the increased speed of the outer wing will counteract the restoring effect of the side-slip, and the aeroplane will continue to turn with increasing bank and angular velocity. The manoeuvre if not controlled ends in a spiral dive."

"Dec. 8 1913.—In this experiment, the rudder was adjusted for straight flight and then held fast by the feet, friction of the heels against the floor making absence of movement certain. When all was ready the aeroplane was disturbed by the wing flaps, which were then returned to their normal position. The experiment is rather delicate, as any want of symmetry will cause the aeroplane to be stable when rolled in one direction and unstable in the other. It appeared, however, that the aeroplane was just stable, righting herself slowly."

"Complete stability test.—The aeroplane was flown from Long Valley, Aldershot, to Froyle near Alton, and also from Froyle to Fleet, distances of 62 and 8 m., without the use of wing flaps or elevator. The wing flaps were left free as usual and the elevator was locked. The flying was very comfortable, and the pilot considered that reconnaissance under these conditions would be considerably easier for a pilot alone."

For normal flight the description of lateral stability given in these abstracts still represents the position. The experiment is still delicate and it may be doubted whether any aeroplane has an appreciable degree of lateral stability. The early work on stability cleared the way to a large extent; the temptation to

<sup>1</sup> Accidents Investigation, Advisory Committee for Aeronautics, Jan. 1919. R and M No. 617, also R and M No. 629, Dec. 1918.

<sup>2</sup> Supplement to Aeronautical Jour., July 1919.

complex design for safety was removed and dangerous instability rarely exists so long as a pilot is alert. The introduction of aerobatics and the training of pilots to loop, spin, roll, etc., at the same time as it inspired confidence in the ability to control an aeroplane also led to conditions far removed from those of normal straight flight. It was then found that the stability of aircraft under extreme conditions has great importance, particularly when the angle of maximum lift has been reached or exceeded.

A very large proportion of accidents arises from engine failure whilst near the ground. In holding up the nose of the aeroplane whilst attempting to turn back into an aerodrome, the pilot most infrequently stalls the craft and violent lateral instability results. Recovery from the effects of this instability is rare and much study has been made of the phenomenon.

There is now little doubt as to the cause of this instability but the methods of removing it are far less clear. The same cause which produces instability removes the effectiveness of the controls; it is probable that high-lift wings have characteristics antagonistic to those of stability and further investigation of the subject is required before satisfactory design for speeds less than that of stalling can be reached.

More recent papers on various aspects of stability will be found in the reports of the societies and bodies<sup>3</sup> dealing with aeronautics; there are no striking developments but much solid work has been done by a few workers in the subject. There are difficulties in the nature of variation of nomenclature which make the comparison of work laborious and in an attempt to deal with this aspect of the problem of stability the Royal Aeronautical Society, acting as a sub-committee of the British Engineering Standards Association, has drawn up and recommended the use of a particular set of symbols and axes of reference. Still in its infancy as regards application, the subject merits greater attention. It is scarcely likely that the degree of stability—still undefined—thought suitable for military use will be that correct for civil uses. Extreme manoeuvrability is considered to be essential in the first and safety in the second. Whilst not wholly incompatible it is clear that a degree of stability can be introduced without discomfort in a straight and uneventful flying which is disliked for the purposes of aerial fighting. (L. Bw.)

#### IV. MATERIALS AND METHODS OF MANUFACTURE

The aircraft pioneers, being their own designers, builders and financiers, used the simplest design, manufacture and assembly, and the cheaper materials.

Between 1912 and 1914 came a striving for efficiency; fixed charges were relatively high, and research costs were extremely great for the small output of the day; this conduced to the quest for the best materials and made costly machining to reduce weight and establish types permissible. In the World War the aerodynamic advances made in this way were used, but as bulk production set in before schemes and tools for bulk production existed, aeroplanes had to be made regardless of cost until the tools were evolved.

Standardization of materials, of sizes and of parts and components, notably bolts, nuts, bracing connexions, piping connexions, etc., common to most types of aircraft, had previously to 1914 been started, but was extended in 1915 to cover tubes, bracings, methods of jointing, length of bracings, wheels and axles, airscrew bosses, etc. Also some of the larger components, wings, elevators, rudders, and ailerons, which could be utilized on more than one type, were standardized. Master and workshop gauges were made and distributed to ensure interchangeability. Continuous records of tests led to the selection of the most suitable materials, and to standard specifications. These have been continuously evolved up to the present day, and their dissemination has spread far and wide much acquired knowledge.

<sup>3</sup> Reports of the Advisory Committee for Aeronautics to date, *Jour. of the Royal Aeronautical Society*.

Reports of the National Advisory Committee for Aeronautics, United States of America.

<sup>4</sup> *Applied Aerodynamics*, L. Baird.

<sup>5</sup> *Aeronautics: A Class Text*, E. B. Wilson.

<sup>6</sup> *Aeronautics in Theory and Experiment*, Cowley and Levy.

The earliest steps in England, or indeed anywhere, to unify such standards were taken by the Royal Aircraft Factory at Farnborough in 1913. They were extended and improved as experience developed under the Aircraft Inspection Department (A.I.D.) in England (towards the end of 1915), and later under the British Engineering Standards Association, which in 1921 was instrumental in founding in Paris the "Comité International pour l'Unification Aeronautique" to internationalize the same work.

**Components.**—Fuselages, wings, undercarriages, tail planes and controlling surfaces, prior to 1914 were not, save in one or two cases, designed as self-contained units, *i.e.* their manufacture was usually completed during erection into the aeroplane. This involved hand-fitting, trial and error adjustment, constant inspection and slow production, while spares were not interchangeable.

By 1915 each component became a unit in itself, made to limits, corresponding with the connexion points, and interchangeability was safeguarded by the use of jigs and fixtures. By 1919 even components were subdivided into standardized parts, and the assembly of components into a complete aeroplane could be effected after delivery to the field. The jigs and fixtures were usually confined to the location of junction fittings on which the structure was erected. These replaced the fixtures of 1915, which held all members of the component in position during construction, but proved not to be satisfactory, owing to the distortion of the finished piece on removal from the fixture.

Girder types of construction, such as fuselages, wings, etc., were latterly constructed to jigs rather than on fixtures, in order that their truth of erection might be more permanent. Monocoque constructions, however, were always built on cradles or moulds, which definitely determined their final shape; the individual members, being free from initial load, were free from distortion on removal from the mould.

The development of portable gauges (gauge points mounted on tensioned wires) occurred in 1916.

In 1917 component junctions were designed so that all positioning was determined by one joint, clearance in one direction being allowed on the remaining joints; the gauging of components was simplified thereby, and many of the more costly gauges could thus be superseded by simpler ones used in conjunction with a measuring operation.

**Woodwork.**—Wood is eminently suitable for light construction and for obtaining a rapid output by machining. The mechanical properties and suitability of various timbers were little known in 1913. Bamboo, the lightest timber, was found unsuitable in about 1911; it lacks uniformity in size, and is difficult to connect at the end of members. Ash (*Fraxinus excelsior*) and hickory (*Carya alba*, *Hicoria onata*) were early used, but hickory is scarce, and variable in its mechanical properties, and ash is heavy as well. Ash is restricted to use where high flexibility and shock-resisting are essential. Silver spruce (*Picea Sitchensis*, Carr.) was introduced in 1913 for spars, struts, longerons and other members, being uniform, light and suitable for machining for weight reduction.

Between 1913 and 1915 accurate information of the strength and elasticity of this timber was acquired. Methods of converting the timber for the various uses were determined in order to eliminate defects peculiar to coniferous timbers, such as spiral grain, cross and diagonal grain, dot or rot, gum pockets, alternating hard and soft grains, low density, wide-ringed timber and brittle or lifeless timber (brash).

The great demand in 1916 in England led to the importation of unseasoned timber, needing to be conditioned for use. The French and Americans had already experience of this. Kilns were erected in England (on the Sturtevant system of drying). Humidities, temperatures and time periods of drying were determined. Control of the moisture-content of timber was found to be essential.

The larger aeroplanes in 1916 and 1917, and the demand in excess of supply for best of spruce of long lengths, led to spars being made of short lengths joined together, the joints being situated at points of low stress. A study of various joints in 1918 led to the adoption

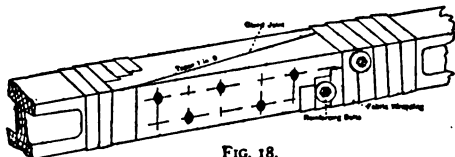

FIG. 18.

of the plain vertical scarf joint with an inclination of 1 in 9, reinforced by bolts through the splice, and bound with fabric (see fig. 18). Shorter timbers glued together as laminations then became permissible for all spars, and defects could thus either be cut out or reinforced. Joints in these laminations, after being admitted for a period, were ruled out in 1919.

To supplement the supplies of silver spruce in 1917 the following

timbers were tried in 1918, the peculiarities of each being allowed for:

- Quebec Spruce (*Picea alba* and *Picea nigra*, Link.).
- White Sea White Deal (*Picea excelsa*, Link.).
- White Sea Red Sea Yellow Deal (*Pinus sylvestris*, Link.).
- West Virginia Spruce (*Picea rubens*, Sargent.).
- North Carolina Spruce (when this is the same as West Virginia Spruce, but grown in North Carolina).
- Louisiana Red Cypress (Bald.).
- Port Orford Cedar (*Chamaecyparis Lawsoniana*, Murr.).
- New Zealand Kauri (*Agathis [Dammara] australis*).
- Canadian White Pine (*Pinus Strobus*, Link.).
- Oregon Pine (*Pseudotsuga Douglasii*, Carr.).

Cypress, which is very variable, liable to brittleness and unsuitable for gluing, was barred in 1918. Oregon pine, which is liable to fracture under shock, and may split when cut into small dimensions, must be restricted to struts and used in the solid. Small knots in the deals can be allowed in laminations if the knots be distributed to obtain uniformity of the member. Laminated struts were used in 1919, with fabric binding to safeguard against the opening out of joints. Early in 1918 box sections, which have all the advantages of laminating, were used, and their use continues.

About 1915-6 the glues used in the above processes were classified into three grades: (1) the best for aircrews; (2) for less highly stressed joints; (3) for unimportant details. Glue shops were maintained at a constant 70° Fahrenheit. Micro-investigation of glued joints proved the value of carefully preparing the timber and glue; timber was aged to prevent warping, by storing in the 70° F. rooms for long periods before gluing. Roughing of the surfaces to be glued was adopted to secure keying.

In 1915-6 it was found that if an entire series of laminations were glued in one operation before clamping the first joint would become chilled before the clamping occurred. Later, by using trained crews and special appliances for quick gluing and clamping, the *en bloc* process of gluing with the more rapid output became possible and satisfactory. Where heated-gluers could not be used, "liquid" glue or jelly glues (containing an ingredient which delays the setting point of the glue, thus allowing of ordinary temperatures—55° F. to 60° F.—with ample time for assembly of parts) were adopted.

**Metal Fittings.**—In 1916 fittings for the structures, attachment of bracings, etc., were made of mild steel, a metal selected, no doubt, because it could be worked cold. This was often used in double thickness to ensure against flaws. Oxy-acetylene welding was often used in joints, even in some that were subject to stress. Tubes and plates were welded together to make sockets, and bent to shape without being subsequently normalized. Failures at welds led to the substitution in 1915 of mild-steel drop forgings. These were machined all over to save weight and to get the size accurate to tolerances too small for the stamping industry at that time.

The correct temperature for forging and subsequent heat treatment of the forging in high tensile steel was not currently known. The facilities were lacking, and the control of the temperatures needed was left too much to the estimate of the skilled operative. Stampings brittle and unreliable for use, as well as difficult to machine, were made. In 1915-6 the impact test, long known but little used, was supported by the War Engineering Committee of the Royal Society, and was found valuable for ensuring that the material so tested would bear prolonged shock stress.

By 1917 the call for speedy output led to a reversion from forgings to sheet-metal sockets and fittings, using a low carbon sheet-steel of 26 tons' ultimate tensile strength. The pressings were shaped in jigs which ensured an adequate radius at the bend, and they were normalized to remove strains due to bending or punching. Where complicated fittings were built up of simpler pressings these were riveted and soldered together to avoid welding. Dip-brazing of such constructions came in in 1918, with the advantage that the temperatures could be better controlled than when brazed with a blow-pipe. Such pressings are interchangeable and need less gauging and inspection. Turnbuckles, universal joints, shackles, etc., hitherto machined from the bar, were re-designed for quicker manufacture from sheet metal.

**Bracings.**—In 1910-1 80-ton steel "piano wire" was much used for bracing the structure, but the fastenings for this had only some 60% of the strength of the wire; the loops stretched, and the structure was soon distorted. Flexible cables spliced on to wiring plates and adjusted by turnbuckles were then used with greater safety, but these also stretched and increased the air resistance, to reduce which wooden fairings were applied to the cables. Solid wires swaged to streamline form, and left thick at the ends for screwing, were made as early as 1911, but they were difficult to manufacture. In 1913 this fair section was abandoned for the elliptical, to allow of rolling instead of swaging the rods, while a special steel and heat treatment evolved by the Royal Aircraft Factory overcame the difficulties. These wires were not generally adopted till, in 1915, standardized aeroplanes led to a demand which warranted bulk production.

Wires of streamline section were swaged, not rolled, because these unsymmetrical sections tend to curve over sideways as they pass out from the rolls. The elliptical-section wires were called "Rafwires," to distinguish them when they were standardized. The screwing of the end of these wires was carried on after heat treatment (at 550° C.). Subsequently the wires were tempered at a lower temperature

350°C.), and later the tempering was abandoned. Round swaged tie-rods were made from the same steel as the streamline wires drawn to an ultimate strength of 80 tons per sq. in. without any subsequent heat treatment. The adoption of tie-rods and streamline wires for bracing extended the period for which the aeroplane retained its truth, while it was improved both in speed and climb by the fair wires.

Flexible cables used for controls consisted generally of seven strands, each of 19 wires of 90-ton tensile. To increase the war out a single lay cable of larger strands was used. This cable could not be spliced, and joints were made by turning the ends, wrapping with wire, and soldering—a process that requires much care.

In a few cases in 1919 the structures were built on the strut-tie principle without wire bracing; this gave quick erection and maintained very well the truth of structure.

**Dope.**—The fabric stretched over the wings becomes slack after exposure to alternations of humidity. Prior to 1909 rubber cotton fabric was tried, and alternatively the plain cotton was tautened by painting with flour paste. In 1909 thin sheets of cellulose acetate were applied over the cotton, and later the substance was dissolved in acetone and applied with a brush, camphor being used to keep the coat pliable; however, the camphor evaporated, and thereupon the dope cracked on exposure. The search for a suitable softener that did not evaporate from the dope was prosecuted. Tetrachlorethane was tried with success, but it proved dangerous to the operatives applying it in enclosed places. Moreover, sunlight decomposed tetrachlorethane; to yield hydrochloric acid, which eventually attacked the fabric.

In 1916 benzyl-alcohol was tried with success. When the evil effect of light on linen and dope was discovered in England a pigment varnish was introduced by the Royal Aircraft Factory (P.C.10) which protected the fabric and dope from light and increased the life of both. In 1916 a nitrocellulose dope was introduced, to economize in the acetic-acid radicals which were in demand elsewhere for explosives. From 1916 onwards the acetate and nitro dopes were used; to them benzyl-alcohol was added to render the film plastic, and triphenyl-phosphate to render the film waterproof and fireproof. After removing all saponifiable grease from the fabric the dope was applied by hand in three to five coats, till 1918, when spraying was introduced for the coats other than the first, which needed to be well brushed in. Constant temperature and low humidity are required in dope-rooms to avoid the deposit of water due to evaporation of the solvents.

**Rubber Hose.**—Rubber tube introduced in pipe lines to give flexibility is deteriorated by petrol and oil. In 1916 some resistance to petrol was introduced by using pure para heavily loaded with mineral matter and rather over-vulcanized. This withstood boiling petrol for one hour, and immersion for 23 hours, but its life in use is very short and it frequently required renewal after four months.

**Engine Testing.**—The aircrew, the flat plate air brake, the electric dynamo and the water dynamometer of Heenan and Froude were used for testing aero engines.

Later the Escargot reaction torque brake was evolved, corresponding in principle to the Heenan and Froude water brake in that an air fan brake is rotated inside a closely fitted case, into which the air is drawn through central ports and expelled centrifugally through tangential outlets at top and bottom; the engine, mounted on a

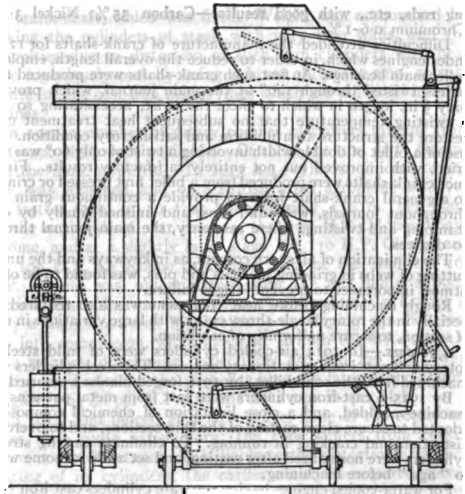

FIG. 19a.

built-up stand pivoted about the propeller shaft axis, is held and the torque measured with a graduated bar and counterpoise.

To vary the power absorbed at a given speed, the Fell type of Escargot (see figs. 19 and 19a), introducing Butterfly valves in the tangential outlets, was developed late in 1917. Restriction of the air outlet from the Escargot perforce reduces the work to be done by the fan on the air, which tends to rotate with the fan and so increase the speed of the engine to a corresponding degree. A power curve range is thus obtained comparable with that given by the Heenan and Froude brake. The Escargot method provides a ready means of cooling air-cooled engines by taking special ducts from the outlets to the engine cylinders, whereas the Heenan and Froude brake requires a separate cooling-fan and driving-motor.

In determining the useful H.P. of rotary engines, "windage loss," or the power absorbed by the engine itself, had first to be determined for each type, and then deducted from the total nominal power, calculated on the weight bar reading. Originally the bench tests comprised an endurance test of four hours, followed by complete dismantlement and examination for defective parts, excessive wear, reassembly, and final one-hour test, the engine being run throughout at normal speed and at full throttle, petrol and oil consumptions being recorded in both tests. Subsequently all-round experience and increased reliability of materials and their treatment permitted of a reduction of this endurance test, first to three hours, and then to two hours, with a final half-hour test. The engine throughout, save for the last five minutes, was throttled down to 90% and sometimes even to 80% of full power at normal speed, to prevent the overheating of and detonation in the relatively high compression engines. Such engines were designed to give full power at 5,000 ft. height rather than at ground level.

Standardization of the actual flow measurement of carburetter jets in place of orifice-diameter calibration made it possible to tune up engines for bench tests on a few minutes' running only. Also standard jets suitable for flight purposes were substituted for bench-test jets before delivery, so that the time of tuning-up on installation of the engine into the aircraft was diminished. In 1916 a petrol-flow meter, whereby the actual flow into each carburetter is indicated, facilitated the determination of petrol consumptions.

**Crank-shafts.**—The aero-engine materials were covered by definite specifications originally issued by the Royal Aircraft Factory. The chemical composition was closely defined, heat treatment provided for, and an Izod Impact Test added to the usual tensile test, to give some indication as to the shock-resisting power of the material. The Izod Impact Test, though it does not reproduce the alternating and fatiguing stresses of actual running, has proved to be indispensable in detecting steel which has been improperly heat-treated. "Temper brittleness" induced in alloy steels by slow cooling from the tempering temperature, even after correct initial heat treatment, is detected by the 2-3 ft. lb. obtained as compared with the 25-30 ft. lb. with the identical steel if properly heat-treated and quenched after tempering. This brittleness, which obviously unfits steel for crank-shaft use, cannot be detected otherwise than by the impact test, since the usual tensile results and micro-structure examination in no way differentiate between the sound and temper-brittle conditions.

Early in 1915 the British Aeronautical Inspection Directorate suggested the following nickel chromium steel for crank-shafts, connect-

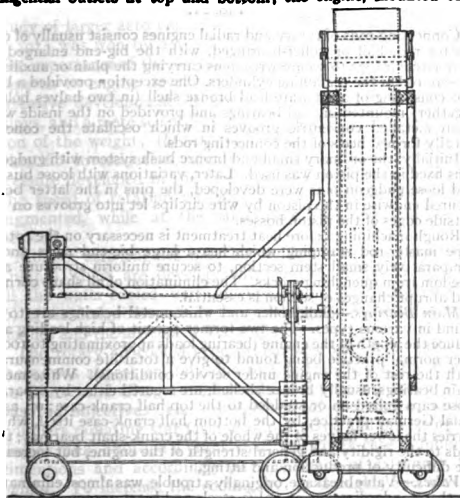

FIG. 19.



ing rods, etc., with good results:—Carbon 35%; Nickel 3.5%; Chromium 0.6-1%.

Difficulties attended the manufacture of crank-shafts for 12-cylinder engines which, in order to reduce the overall length, employed roller main bearings. At first such crank-shafts were produced from billets twisted through 120° at the main journal, which provided only  $\frac{1}{2}$  in. length in which to effect the twist, necessitating so high a twisting temperature that no subsequent heat treatment could restore the structure to a uniform and satisfactory condition. The use of a billet of double width involving a twist of only 60° was then tried, with improved but not entirely satisfactory results. Finally such crank-shafts were produced from a billet first pressed or crinkled to a general crank-shaft form to provide a continuous grain flow throughout journals, webs and pins, and finished finally by drop stamping and twisting, where necessary, the main journal through 60 degrees.

The elimination of all sharp corners, as in keyways and the under-cutting of webs in grinding journals and pins, was found to be of the utmost importance to prevent fatigue failure.

Rough machining before heat treatment was also required, especially in the rotary single-throw crank with large variations in mass of section, to secure uniformity of condition.

**Cylinders.**—In 1914 air-cooled cylinders were of mild steel for rotary and cast iron for stationary engines. The steel cylinders were machined from the solid billet; by 1916 forged blanks were used.

By 1915-6 cast-iron cylinders were cast from metal patterns and machine-moulded, and a close limitation of chemical composition adopted to secure clean casting of the thin sections, and to overcome distortion and cracking in running. To eliminate casting stresses cylinders were normalised after casting, and set aside for some weeks to "age" before machining.

For water-cooled engines having separate cylinders cast iron (with a sheet-steel jacket pressed to shape, and welded on, or a copper jacket electrically deposited) was used. To allow the jackets to expand, crinkles, both circumferential and round the exhaust valve seatings, and sparking-plug bosses were introduced, as the local expansion of the jacket differs from that of the cylinder when running.

Later, mild-steel cylinders turned from forged blanks were used in lieu of cast iron. Valve pockets, sparking-plug bosses, and thin sheet jackets were then welded on as first tried by Vickers in 1909.

Aero-engine cylinders are also cast together in one block for the sake of the rigidity of the cylinders one to another. At first, following motor-car practice, cast iron was used for this. Towards the end of 1916, however, aluminium, with its low weight and high heat con-

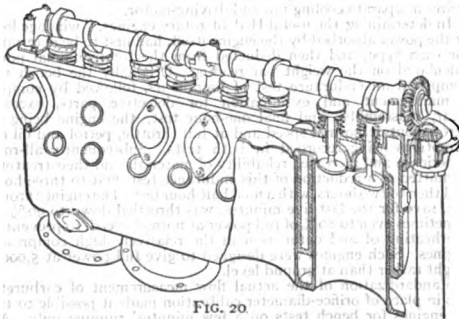

Fig. 20

ductivity, took its place. The first prominent "Mono block" (see fig. 20) comprised a mild-steel cylinder liner complete with head and valve seats, screwed into an aluminium block which took four cylinders, and constituted a complete enclosed water-jacket. The liners were not in contact with the cooling water, and with bigger cylinders overheating and loss of contact between the liner and the surrounding aluminium jacket occurred particularly in the flat head. A natural development, therefore, was to remove the top of the liner, leave it open, and let the aluminium itself form the combustion head of each cylinder. Two difficulties then had to be overcome:—(1) The provision of a gas-tight joint between the top of the liner and the jacket and head; (2) the insertion of rings in the head to form valve seatings. The first was overcome by screwing the liner hard up against the shoulder in the head, and the second (which was achieved without distortion or burning of the seatings) by casting-in or expanding-in steel or hard bronze rings. To improve further the cooling of the cylinders, the lower portion of the aluminium jacket in contact with the liners was omitted, the liner being held only by a screw thread of some 1-in. depth at the top and a rubber joint and ordinary lock nut ring at the bottom.

The form of aluminium cylinder head and jacket casting is complicated, and experiments, both as regards method of casting and choice of aluminium alloy, led to the selection of a mixture of

12.5% to 14.5% zinc, 2.5% to 3.0% copper, alloy with virgin aluminium. The pouring temperature is 660°C. The percentage of scrap is high, say, 10% to 15% in the simplest forms of block, and up to 30% or 40% for more complicated designs. To overcome the porosity of castings, stove enamelling of the interior of the blocks or the application of water-glass under pressure is used.

The Royal Aircraft Factory experiments in 1915 led the way in air-cooled stationary cylinder engines in the use of aluminium heads gilled for cooling, using a steel liner and inserted valve seatings. For rotary-engine cylinders in one instance a thin steel liner was shrunk into a flanged aluminium shell which formed a jacket, the head of steel being secured to the liner with a plain metal-to-metal joint by bolts from the head to the crank-case, thus securing the cylinder as a whole.

Cylinders of all types before erection on engines are tested internally to 450-500 lb. hydraulic pressure, and for the jackets to 30-40 pounds.

**Connecting Rods.**—Connecting rods, as regards material, followed crank-shaft practice in the standardization of plain nickel chrome steel, heat-treated to give 50-60 tons' tensile strength.

The 6-cylinder and early 8- and 12-cylinder types conformed to motor-car practice in the use of solid "H" section shanks and white-metal big-ends, without a bronze bush, the cap being held usually by four bolts or studs. To reduce the crank-shaft length of certain "V" type engines the connecting-rods on one side of the engine were provided with lugs to carry a wrist-pin, this wrist-pin, on one side of, and parallel to, the big-end bearing, carrying the auxiliary connecting-rod. Alternatively to the same end a pair of rods superposed. In one case, a hollow circular sectioned shank carried an integral big-end, white-metalled internally and externally, the second rod, being fork-ended, oscillating on the sleeve formed by the first rod. The comparatively thin and flexible section of the inner rod sleeve, however, enhanced the difficulty of white-metalling and led to cracking in running.

A further development therefore (of square hollow sectioned shank) provided a bronze shell rigidly gripped by the forked ends of the outer rod, while the inner rod oscillates on the middle portion of the shell, which is white-metalled internally to provide the main big-end bearing, as shown in fig. 21.

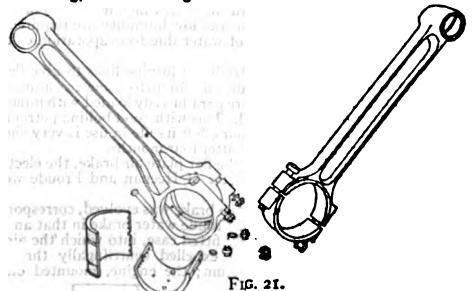

Fig. 21.

Connecting-rods of rotary and radial engines consist usually of one master rod, ball or roller-bearinged, with the big-end enlarged to form circular lugs to secure wrist-pins carrying the plain or auxiliary type of rod of the remaining cylinders. One exception provided a big-end consisting of a separate lead bronze shell (in two halves bolted together) mounted on ball bearings and provided on the inside with white-metalled concentric grooves in which oscillate the concentrically formed heels of the connecting rods.

Initially, the ordinary small-end bronze bush system with gudgeon pins fixed in the piston was used. Later, variations with loose bushes and loose gudgeon pins were developed, the pins in the latter being secured endwise in the piston by wire clips let into grooves on the outside edges of the piston bosses.

Rough machining before heat treatment is necessary on the rotary type master-rod stamping which has a large big-end mass and a comparatively small stem section, to secure uniform structure and freedom from quenching cracks. The elimination of all sharp corners and abrupt changes of section is essential.

**Main Bearings.**—Ball, roller and white-metal bearings are to be found in various types. The two former permit of high loading and reduce the length of the engine (bearing loads approximating to 100% over normal practice being found to give a total life commensurate with the rest of the engine under service conditions). White-metal main bearings, usually bronze-shelled, are secured either by separate loose caps bolted on or studded to the top half crank-case; or, as in usual German practice, by the bottom half crank-case itself, which carries the lower halves of the whole of the crank-shaft bearings; this adds to the rigidity and general strength of the engine, but increases the difficulty of production and fitting.

**Valves.**—Valve breakage, originally a trouble, was almost eliminated by the standardization of valve steels and by stamping the valves

be that the main flow in the valve head stem continuously and uniformly from the rim into the chest and stem, thus providing strength to resist shear at all points of the head. The original practice, before bulk production warranted the use of stampings, had been to turn valves from the solid bar, a procedure which gave in the head a grain flow parallel to the stem.

For exhaust valves a steel having 14% tungsten and 3.5% chromium is necessary in certain of the "hotter" stationary-type engines. For the cooler-running engines a high-chromium stainless steel gives satisfaction. Either of such steels would be satisfactory for inlet valves, but, for economy of such high-grade materials, a plain nickel steel is used with great success. (R. K. B. W.)

V. AERO ENGINES

*Historical Résumé.*—For many years mechanical flight was delayed for want of a light engine, and indeed from the first flight to the present day (1921) the aeroplane was ahead of its prime mover. Flight should have been possible in 1902 when Manley, in the United States, built for S. P. Langley a five-cylinder radial petrol engine developing 52 H.P. and weighing only 2.9 lb. per H.P. By bad fortune this engine was, however, never used in flight until 1914, when it was mounted in the Langley aeroplane for which it was intended.

For their first flights in 1903, the brothers Wright built a four-cylinder car-type engine of 12 H.P. weighing 12.7 lb. per H.P. By 1905 it was improved to 19 H.P., with a weight of 9.5 lb. per H.P. and, as redesigned in 1908, gave 35 H.P. and weighed 5.5 lb. per H.P.

The aero engine proper dates from about 1909, and the progress made is traceable reliably by the results of competitive tests held from time to time. Such tests were carried out in France, 1909-12-13, in cooperation with La Ligue Nationale Aérienne and the Auto Club de France; in England in 1909-12-14; in Italy in 1913, and in Germany in 1912-4.

A certain section in England centred its hopes erroneously on the use of very small engines. A. V. Roe made the wonderful achievement of flying an aeroplane with only 9-10 H.P. in 1909. The Alexander prize of 1911 at first stipulated for engines of only 25 H.P. This was increased by the Advisory Committee at the request of the supt. of the Army Aircraft Factory to admit "40 to 75 H.P." and was won by 24 hours' continuous running by a 50-60 H.P. Green sent in on Sept. 11 1911. This engine weighed 296 lb. complete, and developed an average of 53.5 H.P. The British Government competition of 1914, although won by a 110 H.P. Green engine, was chiefly useful in showing the merits of the 100 H.P. Gnome and the 90 H.P. RAF. Both of these did yeoman service in the war, but soon proved to be too small.

In Germany, the development of the airship led to the earlier study of larger aero engines, although the German competition of 1914 was won by a 100 H.P. Benz, weighing 4.2 lb. per H.P. The importance of the aeroplane in war service gave an immense impetus to engine development along two main lines: (a) An extensive development of high tensile steels and aluminium alloys, and a more scientific use of the materials, led to a diminution of the weight; (b) attention to detailed design, guided by scientific investigation, greatly increased the mean effective pressure developed in the cylinders and the thermal efficiency. The speed of rotation was also increased so that output was augmented, while at the same time fuel consumption was reduced.

Modern aero engines may be divided into two classes:—(a) Engines which are developments of the motor-car type, i.e. all the water-cooled vertical, Vee, and broad-arrow engines; (b) types designed specially for aerial flight, i.e. the radial rotary engines and the air-cooled Vee engines.

The rotary air-cooled type, which was one of the earliest of these, was almost entirely due to the French, e.g. the Gnome, Le Rhone and Clerget engines. In this type minimum weight was the objective. The arrangement of the engine, with its cylinders radiating star fashion in one plane and operating on a single crank, afforded a crank-shaft and crank-case of minimum dimensions and accordingly gave a motor of extremely light weight. To increase the cooling by air draught, and save the weight of a fly-wheel, the cylinders were made to rotate round

the crank-shaft, which was fixed. Weight was economized by making the cylinders of steel, with very thin walls, and the difficulties due to distortion of such thin cylinders with heat were ingeniously met by using a brass obturator ring, as substitute for the cast-iron piston rings which are universal in other engines.

In 1909 a number of rotary engines of powers ranging from 30 to 100 H.P. were available. Of these the 100 H.P. Gnome was the most powerful. In 1913 a 14-cylinder Gnome of 160 H.P. was launched, and on a British army aeroplane achieved the fastest flight up to that time, namely 130 m. per hour. At the outbreak of war in 1914, the 100 H.P. Monosoupape Gnome, and at a slightly later stage the 110 H.P. Clerget and the 100 H.P. Le Rhone came into current use, and the 160 H.P. Gnome was, unfortunately from the war fighter's point of view, discarded on the score of complication. In France in 1917 a higher-powered Monosoupape developing 150 H.P. was put into commission, while in Great Britain the BR1 and the BR2 rotaries, developing respectively 150 and 220 H.P., were produced. Including the propeller boss the later Mono-Gnome weighed 2.03 lb. per H.P. and the BR2 2.21 lb. per H.P.

In 1914, and indeed at a later stage, none of the rotary engines were quite satisfactory; the type suffers from certain inherent disadvantages. It is liable to the distortion and overheating of its cylinders; the earlier examples required special precautions against catching fire; its petrol and oil consumptions are high; and it requires frequent dismantling and overhauling.

In spite of this the best of these rotaries formed the basis on which European air experience was founded, and as recently as 1912 the best aero engines (from the point of view, be it understood, of the aeroplane's performance, which is dominantly a matter of weight) were probably the Gnome rotaries weighing from 3.0 to 3.5 lb. per H.P. At this time long-distance flights were exceptional and therefore their large fuel and oil consumption was not so serious. Throughout the war, and especially in its earlier stages, they gave their best service in machines of the single-seater high-speed class, in competition with the heavier water-cooled vertical engines on which the German air service relied almost entirely.

When the distance of flight was extended, the water-cooled car-type engine came to the front partly because the smaller weight of fuel to be carried compensated for the greater weight of the engine itself, and partly because it was at that time more reliable. The following table shows the total weights of engine, fuel and oil, for flights of different duration, in the case of a typical air-cooled rotary engine weighing 2.25 lb. per H.P. and consuming 1.10 lb. of fuel and oil per H.P. hour, and of a water-cooled engine weighing 4.0 lb. per H.P. and having a total consumption of 0.55 lb. per H.P. hour.

Duration of flight (hrs.)	Weight of engine, petrol, oil (lb. per hr.)					
	1	2	3	4	5	10
Rotary air-cooled engines	3.25	4.45	5.55	6.65	7.65	12.25
Water-cooled engines	4.55	5.10	5.65	6.20	6.75	9.55

For longer flights than 3 hours the water-cooled engine is here shown to involve a smaller gross weight.

It was largely, emulation of the rotary which forced the pace of the progress on the car-type engine. This led to the replacement of cast iron by sheet metal for water-jackets; to the use of thin steel instead of cast iron for cylinder barrels and of aluminium for cylinder-head castings; and to the use of two, and in some cases three, rows of cylinders operating on a single crank-shaft and mounted on a common crank-case. The use of steel or aluminium alloy instead of cast iron for the pistons had been initiated in experiments for motor-cars. In some few cases air-cooling was adopted, e.g. in France the 70 H.P. eight-cylinder Vee Renault of 1912, and notably in England the 90 H.P. eight-cylinder Vee RAF of 1913-4, and the 140 H.P. twelve-cylinder Vee RAF.3, all of which had cast-iron L-headed cylinders. The last-named engine weighed 4.0 lb. per H.P. and gave excellent service during the war.



Still the car engine of given cylinder capacity remained appreciably heavier than the contemporary rotary, until careful studies in 1916-17-18 were made to increase the output per unit of cylinder volume, and the thermal efficiency.

The volumetric efficiency was increased by improving the design of the inlet pipes, valves, and valve gearing, and the combustion space of the cylinder. The thermal efficiency and the mean effective pressure were increased by augmenting the compression. Since high compression is only practicable with a compact and symmetrical combustion chamber the L-headed cylinder was replaced by the overhead valve-cylinder. Moreover, since high compression necessitates good cooling of the cylinder, the water-cooled engine gained a distinct relative advantage over the earlier air-cooled engines which were, in general, inadequately cooled. As a result of these steps in the detail design, the brake mean effective pressure was raised from the 75 to 95 lb. usual on cars, to as high as 130 lb. per sq. in. in the best modern aero engines, while at the same time the petrol consumption was reduced to approximately 0.45 lb. per B.H.P. hour, a value some 40% better than that of the average car engine.

In many cases the output was also improved by increasing the speed of the engine. The speed of the rotary engine was limited to about 1,200 revolutions per minute, by the stresses due to centrifugal force. In the fixed cylinder engine, however, much higher rotational speeds could be adopted by attention to the balance of the moving parts, and to the design of the bearings. These speeds now range from 1,400 to 2,100 revolutions per minute, reduction gears being used for the airscrew drive in the case of the larger and less rapidly flying aeroplanes.

The resultant weight economy was considerable. Thus the 300 H.P. Hispano-Suiza water-cooled Vee, rotating at 2,000 r.p.m., weighed only 1.80 lb. per H.P. and the 450 H.P. Napier "Lion" of 1921 only 1.89 lb. per H.P. In each case these weights include that of the propeller boss, but not that of the radiator and its water, which would add approximately 0.55 lb. per H.P.

These advances in the car type of aero engine were accompanied by improvements in the specialized type. In 1912 the radial engine with fixed cylinders was represented by a few examples of which the 9-cylinder, water-cooled "Salmson" developing 110 H.P., the 6-cylinder, water-cooled "Laviator"

up to 6 in. and up to 90 B.H.P. per cylinder, give an output and fuel-consumption of similar order to those from the best water-cooled cylinders.

No air-cooled engine with these large cylinders reached the stage of production in quantity during the war. A number of British radial engines were, however, developed in 1918, and of these the "A.B.C. Dragonfly," having nine steel cylinders, giving 300 H.P. and weighing 2.22 lb. per H.P., and the 450 H.P. "Cosmos Jupiter," having nine steel cylinders with an aluminium patch containing the inlet and exhaust ports bolted to each head, and weighing 2.42 lb. per H.P., are worthy of mention.

As compared with these it will be recalled that the 150 Monocoupe of the same date weighed 2.03 lb. per H.P.

A 12-cylinder Vee experimental engine with aluminium cylinders was built at the Royal Aircraft Factory in 1916-7 and gave excellent results in flight and on the test bed. This developed 210 H.P. and weighed 3.0 lb. per H.P.

Prior to 1914 the American aero engine was mostly of the car type, and was outdistanced during the first two years of the war by the more intensive development in those countries actively engaged. At that time the 160 H.P. Curtiss was probably the most outstanding engine in America, and when the United States declared war in 1917 her need for high-powered aero engines became acute. In May 1917 it was decided, in conference with the Allied Mission in the United States, to design and build the Liberty engine, of which an 8-cylinder model was completed for test on July 3 1917. This was not put into production, as advices from France indicated that demands for increased power would render it obsolete before it could be produced in quantity. Efforts were then concentrated on a 12-cylinder model, the first of which passed its 50-hour test on Aug. 25 1917. This engine is a water-cooled Vee, originally developing 400 H.P. and weighing 2.0 lb. per H.P. More recent improvements have increased the output to 510 H.P. and reduced the dry weight per H.P. to 1.75 lb. or about 2.3 lb. with cooling water and radiator.

The progress in the average aero engine in service between 1910 and 1918, in power, weight, and efficiency, is shown in the following table. The main details are abstracted from the report of the American National Advisory Committee for Aeronautics in 1918:—

Engine	Date	H.P.	Weight lb.	Weight per H.P.	Average petrol (lb. per B.H.P.)
Average in service.	1910	54	309	5.7 lb.	.72
" " "	1914	112	437	3.9 "	.65
" " "	1915	133	512	3.7 "	
" " "	1916	185	570	3.1 "	.60
" " "	1917	234	603	2.8 "	
" " "	1918	267	693	2.6 "	.55

developing 80 H.P., and the 6 and 10 cylinder, air-cooled "Anzani" developing 60 and 100 H.P. are among the most noteworthy. The Salmson was developed at a later stage as a 14-cylinder, two-row engine of 200 H.P. and the Anzani as a 20-cylinder, four-row engine of 200 H.P. These engines were French, but since 1914 British designers have greatly advanced the science of the air-cooled engine.

The fixed radial engine has a number of features of superiority over the rotary. It enables a normal type of carburetter and of piston to be used; it eliminates the large windage losses; while since the cylinders are not exposed to centrifugal stresses aluminium alloys can be used. This light and highly conducting metal has greatly helped air-cooling. Owing to the greater ease of installation of the air-cooled engine in an aeroplane, the absence of a fragile radiator liable to freeze on descent from great heights, as well as to its adaptability to work in the tropics, much attention was paid during the war to the design of air-cooled cylinders. A composite construction using aluminium alloy for cylinder heads was evolved at the Royal Aircraft Factory, Farnborough, between 1915 and 1921, with the result that air-cooled cylinders became available which, for diameters

Since the water-cooled engines cannot function without radiator and water, an addition of 0.55 lb. per H.P. has been made in their case to render Table A comparative. The weights after deduction of 0.55 lb. are actual measurements, and include those of the propeller boss and of the gear, if any. In cases where the respective makers produce a series of engines of different powers, only representative examples have been quoted.

During the latter part of the war, the demand for engines of large H.P. for bombing aeroplanes and dirigibles led to the production of many experimental engines, which were available by 1921, e.g. the 800-900 H.P. Sunbeam Coatalen, the 850 H.P. Fiat, the 1,000 H.P. Lorraine Dietrich, and the 1,000 H.P. Napier "Cub."

*Types of Engines.*—Of the total heat from the fuel, 25% to 35% passes through the walls and piston and must be dissipated by water-cooling or direct air-cooling if the normal operation of the engine is to be maintained.

Water- or air-cooling have their respective advantages and disadvantages.

For the water-cooled engine is claimed:—

(1) A lower cylinder-wall temperature; a reduced tendency to the burning of exhaust valves and pistons; and more effective lubrication.

TABLE A.—Details of the Principal Engines Available in 1918 for Service.

Country	Engine	Type	H.P.	Weight	R.F.M.	Wt. per H.P.	
Great Britain	Beardmore	6 cyl. W.C.	170	592	1350	4.85	
	Green	6 " W.C.	170	585	1350	3.99	
	Rolls Royce Eagle	12 " Vee W.C.	300	990	1300	3.85	
	" " Falcon	12 " Vee W.C.	360	947	1800	3.18	
	" " Napier Lion	12 " Vee W.C.	275	715	2000	3.15	
	Sunbeam Arab	8 " broad-arrow	456	850	1925	2.41	
	Maori	12 " Vee W.C.	220	524	2190	2.93	
	Siddeley Puma	6 " W.C.	280	720	2160	3.32	
	B.H.P.	6 " W.C.	290	635	1650	2.74	
	R.A.F.	6 " W.C.	254	604	1400	2.93	
	B.R.T.	12 " Vee A.C.	160	639	1800	4.00	
	B.R.T.	9 " Rotary A.C.	150	410	1260	2.78	
	B.R.T.	9 " Rotary A.C.	224	496	1200	2.21	
	A.B.C. Dragonfly	9 " Radial A.C.	294	651	1650	2.22	
	Cosmos Mercury	14 " Radial A.C.	315	582	1800	1.84	
	France	Hispano Suiza	8 cyl. Vee W.C.	217	484	2000	2.78
		Renault	8 " Vee W.C.	315	858	2000	2.33
Lorraine Dietrich		12 " Vee W.C.	345	924	1300	4.32	
Canton Unne		8 " Vee W.C.	213	834	1450	3.04	
Anzani		9 " Radial W.C.	255	840	1300	4.13	
Le Rhone		10 " Radial A.C.	125	522	1200	4.17	
Clerget		9 " Rotary A.C.	130	350	1280	2.54	
Mono-Gnome		9 " Rotary	125	370	1200	2.96	
		9 " Rotary	105	260	1200	2.48	
		9 " Rotary	154	313	1350	2.03	
Italy	Fiat	6 cyl. Vertical W.C.	317	910	1600	3.42	
	Isotta Fraschini	12 " Vee W.C.	400	805	2260	2.57	
		6 " Vertical W.C.	190	574	1450	3.57	
		6 " Vertical W.C.	300	662	1650	2.77	
	Tosi	12 " Vee W.C.	410	904	1600	2.76	
	Spa	6 " Vertical W.C.	230	507	1600	2.76	
	Anzani	12 " Radial A.C.	100	386	1320	3.86	
Germany	Austro Daimler	6 cyl. Vertical W.C.	200	728	1400	4.19	
	Benz	6 " Vertical W.C.	163	502	1300	4.19	
		6 " Vertical W.C.	235	846	1400	4.17	
	Maybach	6 " Vertical W.C.	200	...	...	...	
		6 " Vertical W.C.	300	801	1400	3.52	
	Mercedes	6 " Vertical W.C.	164	618	1400	4.31	
	6 " Vertical W.C.	252	936	1400	4.36		

(2) A greater uniformity of temperature throughout the cylinder, and therefore less tendency to distortion.

(3) Generally, greater reliability and higher efficiency.

These advantages could justly be claimed over the earlier types of air-cooled engines; to-day they are less clear. Thus the first claim is only justified where great attention is paid to the design and arrangement of the jackets and circulating systems. Measurements confirm claim (2), but also show that the lack of uniformity is not necessarily a serious matter, while troubles from overheated exhaust valves have recently been more prevalent on water-cooled than on the modern air-cooled type.

For the air-cooled engine is claimed—

(1) Smaller weight per H.P. of the complete power unit.

(2) No danger of water freezing on gliding from great heights, or when standing.

(3) Reduced vulnerability in war service and easier installation.

(4) Special adaptability for use under widely differing atmospheric temperatures, and for the tropics.

(5) Better adaptability for application of some supercharging device to give constant power at heights.

Claim (1) is a matter of demonstration, the usual weight allowance for water-cooling being 0.6 lb. per H.P. while the very best is 0.4 lb. per H.P. Claim (2) is admissible to the extent that if freezing be prevented by the use of some other liquid, such as a mixture of alcohol and water, the alcohol evaporates unless the temperature of the fluid is kept below about 70° C. which increases the radiator size.

There is undoubtedly a future for the air-cooled engine of the fixed-cylinder type up to a certain size of cylinder. What this limit of size may be is not known at present. Cylinders of 8-in. bore by 10-in. stroke developing over 100 H.P. have been made and proved to be possible, and investigations on cylinders up to 10 in. in diameter are in progress. Twelve 6-inch cylinders would give 600 H.P., a useful size at present, and an 800 or 900 B.H.P. air-cooled engine is certainly feasible.

**Design of Air-Cooled Cylinders.**—The use of aluminium alloy for the cylinder heads has largely concluded to these results. In a normal design the middle portion of the head is the hottest point because the flow of cooling air and the placing of fins at this point is impeded by the inlet and the exhaust valve ports and valve gear. Most of the heat has to be conducted outwards till dissipated from the periphery of the combustion head, and the aluminium alloy effects this well, both because its conductivity is 3.5 times greater than the steel, and

because being 0.4 of the density of steel it may be used in ample thickness.

Such a cylinder must be of composite construction, since the valve seats and the working surface of the cylinder barrel must be of some harder material than aluminium. The valve seats may consist of rings of steel or of bronze, and these may be either cast or expanded into position. Tests appear to favour a steel barrel with integral cooling fins, screwed into an aluminium head for diameters as large as eight inches.

**Arrangement of Cylinders.**—Aero engines may be subdivided according to the arrangement of their cylinders, into the following types:—

(1) Single line engines suitable for water-cooling.

(2) Vee engines suitable for water- or air-cooling.

(3) Broad arrow engines suitable for water-cooling.

(4) Radial engines—fixed cylinders / air-cooling.

(5) Rotary engines suitable for air-cooling.

The general arrangement of these types is shown in fig. 22.

The straight line engine (a), with six or eight cylinders in line, offers a low head resistance and is accessible. On the other hand its fore-and-aft length is large. The crank-shaft and crank-case are long, and hence the type is heavy.

In the *Vee type* engine (b) two lines of cylinders are used inclined to each other to form a Vee in elevation, and the corresponding port and starboard cylinders operate a common crank-pin. Weight is saved on crank-shaft, case, and valve gear.

In the *Broad Arrow* (c) three lines of cylinders are used as above with further weight saving.

In the *Radial engine* (d) economy of crank-shaft and case is carried to its logical conclusion. The cylinders are mounted in one plane at equal angular intervals around the crank-shaft. All the connecting rods operate on a single crank-pin. The small fore-and-aft length of the engine helps the aeroplane designer but its considerable diameter may hamper him.

To obtain explosion impulses at equal intervals throughout each revolution an odd number of cylinders must be used, the usual number being seven or nine. Where a larger power is required two rows of cylinders may be used, operating a two-throw crank-shaft. The radial cylinders may be stationary or rotating. In the latter case the aircrew is mounted on a continuation of the rotating crank-case. The rotating cylinder engine is quite unsuited for water-cooling. Although the radial engine with fixed cylinders is not well

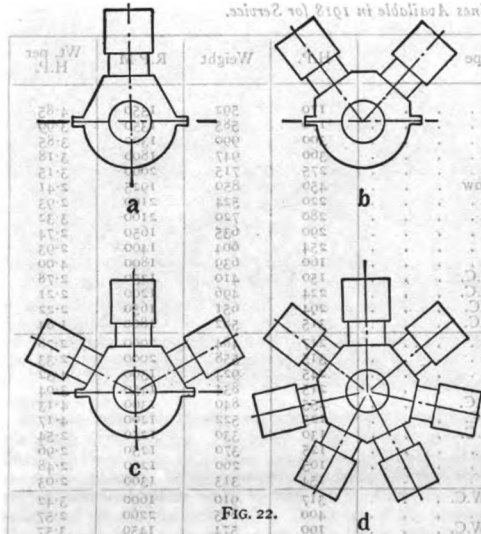

Fig. 22.

adapted for water-cooling, engines of this type have been built and operated successfully. Among these is the recent 300 H.P. 9-cylinder Fiat, weighing 1.7 lb. per H.P. The difficulty of arranging the water circulation so as to avoid all danger of air locks in the inverted cylinders is, however, appreciable, and the head resistance of the completed engine is large. For these reasons, there is not likely to be any great future for the water-cooled radial engine on aeroplanes of present types.

**Installations of Air-Cooled Engines.**—Some form of cowling is needed to distribute the air evenly over the various cylinders, and the success of a Vee engine depends largely on the cowling, whereas even air-cooling is more easily obtained on a "radial."

With rotary engines the cooling is not as good as might be expected from the high peripheral velocity, and the windage losses, even with a cowling, amount to some 10% of the total power developed.

In these engines the air-petrol mixture is led through the hollow crank-shaft to the crank-case. In the original Gnome engine automatic inlet valves fixed in the piston heads and opened by the suction on the inlet stroke admitted the charge. These valves were light, often broke, and were inaccessible.

In the Monosopape Gnome valve in the piston is eliminated and a mechanically operated valve in the cylinder head is used. This serves as an exhaust valve, but, instead of closing at the end of the exhaust stroke, it remains open for a part of the inlet stroke and then admits air to the cylinder. When it closes, the further motion of the piston produces a partial vacuum in the cylinder, until, near the end of its stroke, the piston uncovers a ring of openings in the cylinder walls communicating with the crank-case. The fuel jet is adjusted to give a mixture too rich to be explosive, and this mixture enters into the cylinders and mixes with the air admitted through the inlet valve to form an explosive charge.

Other modern rotary engines have mechanically operated inlet and exhaust valves, with which efficient valve timing becomes possible. The mixture in the crank-case then passes into a circular box fixed to the rear of the crank-case and rotating with it, whence it is led by inlet pipes to the cylinders in the ordinary way.

These methods of mixture supply, though crude, gave the rotary engine the advantage of having a fuel supply adjustable by hand to suit the air density when flight at great heights first became important. On the other hand, the non-rotary engines, fitted with normal carburettors, received a mixture too rich for efficient operation at considerable heights. To obviate this, automatic carburettor controls had to be devised, but pending this the rotary engine had a distinct advantage for high flying.

The lubrication of the rotary engine is peculiar to the type. All oil in the crank-case is thrown centrifugally into the cylinders, and once there cannot be drained out, cooled, and circulated again as in fixed-cylinder engines; but must be discharged through the exhaust valves. Consequently the oil consumption is high. Moreover the lubricating oil must be insoluble in petrol, so that castor oil is necessary.

The power of the rotary engine falls off more rapidly with height than that of the fixed-cylinder engine if the latter has a suitably controlled carburettor, and at a height of 15,000 ft. the difference in horse-power is about 10 per cent.

**The Differential Engine.**—For large powers, each of the two types of radial engine has its own peculiar limitations. In the fixed radial the fly-wheel effect is small, while it becomes difficult to design an engine exceeding about 400 H.P. on a single crank because of the excessive load on the big-end of the connecting-rod. In the rotary radial this difficulty is less, but windage losses, centrifugal stresses, gyroscopic effects and valve-gear difficulties are encountered.

The "differential" engine has been proposed to combine some of the advantages of each type. Here the cylinder ring rotates in one direction and the crank-shaft in the opposite direction at the same speed. In this way the big-end loading may be kept within reasonable limits; the gyroscopic effect is negligible; centrifugal forces and windage losses are comparatively small; and the speed of rotation is low enough to permit an efficient airscrew to be fitted.

If the big-end loading be taken as the criterion, the power of the differential engine is about 30% greater than that of the fixed radial engine; or, deducting the windage loss, about 26 per cent. Whether this advantage outweighs the complication in design, remains to be proved.

**Cycles of Operation.**—All aero engines are of the single-acting type in which driving impulses are received on one side only of the piston, and in the majority of engines the four-stroke cycle is adopted. The two-stroke cycle has not hitherto been adapted successfully to the aero engine, owing to its comparative inefficiency in a high-speed engine which requires to operate over a wide range of speeds.

A six-stroke cycle is in the experimental stage. It consists of the four-stroke cycle with the addition of a suction and compression stroke. The first suction stroke draws in a charge which is compressed into an auxiliary reservoir on the succeeding stroke. The next stroke is also a suction stroke which draws in another fresh charge. At the end of this stroke a valve opens and admits to the cylinder the charge compressed during the preceding stroke, and during the succeeding stroke both charges are compressed into the clearance space and fired. In this way a charge of double weight is obtained and the mean effective pressure during the expansion stroke is twice as great as in the four-stroke cycle. The mean effective pressure over the whole six strokes of the cycle is thus 33% greater than the mean effective pressure over the whole four strokes of the ordinary cycle. Since the explosion pressures are approximately twice as great as in the four-stroke cycle the cylinder construction is heavier.

For evenness of turning moment, the two-stroke is better than the four-stroke, and this than the six-stroke cycle.

In each of these cycles the mixture is drawn into the cylinder, compressed, burnt at constant volume, and expanded to the same volume as before compression. The theoretical efficiency of this cycle

is given by the expression  $\eta = \left(\frac{1}{r}\right) \gamma^{-1}$  where  $r$  is the ratio of the

volumes before and after compression and  $\gamma$  is the ratio of the specific heats of the working fluid at constant pressure and constant volume. This is known as the air standard efficiency. It assumes that the specific heat is constant at all temperatures, and that there is no loss of heat to the walls of the cylinder, in which case the value of  $\eta$  is 1.408.

Taking into account the variation of specific heat with temperature, the appropriate value of  $\eta$  in this expression becomes 1.295 and except for losses of heat to the cylinder walls and piston, the efficiency of an aero engine should attain the values corresponding to its compression ratio, which are—

Compression ratio	4.0	4.5	5.0	5.5	6.0	6.5	7.0	7.5	8.0
$\eta = 1 - \left(\frac{1}{r}\right) \gamma^{-1}$	.336	.359	.378	.396	.411	.424	.437	.449	.460

These figures indicate the importance of a high compression ratio. This is particularly important in the case of an aero engine, since the drop in power with height diminishes as the compression ratio is increased.

A limit is, however, set to the compression ratio in practice by the tendency of a petrol-air mixture to detonate when compressed to a high pressure and temperature. Such a mixture has a "spontaneous ignition" temperature corresponding to any definite pressure, at which it will detonate, and should this combination of temperature and pressure be attained in operation it is apt to cause overheating of the sparking plugs and to lead to general overheating of the cylinder and ultimately to pre-ignition.

The tendency to detonation depends largely on the design of the combustion chamber. It is less where this is compact and symmetrical than where it contains pockets as in a cylinder of the L-headed type. It also depends appreciably on the position of the sparking plugs, and on the composition of the fuel. The addition of benzol or benzene to petrol enables a higher compression ratio to be used, but owing to the comparatively high freezing-point of benzol, not more than about 25% can be used in admixture with petrol, for use at great heights.

By attention to design it is now found possible to use compression ratios as high as 5.5 when using petrol as a fuel, and as high as 6.5 when using petrol-benzol mixture. With such compression ratios,

fuel consumptions in the neighbourhood of 0.45 lb. per B.H.P. hour may be attained.

**Supercharging for High Flying.**—Since the power is proportional to the weight of petrol-air mixture taken in per cycle, and since this weight depends on the density of the surrounding atmosphere, the power falls off with the height reached. Tests show that in the average engine the power is sensibly proportional to the atmospheric pressure. The law of variation with atmospheric density varies slightly with the type of engine, but may be taken approximately as—

B.H.P. is proportional to  $\rho^n$  where  $\rho$  is the density, and  $n$  varies from 1.1 to 1.3, increasing slightly with the height. At different heights the power developed by a 200-H.P. engine at a constant engine speed is thus approximately as follows:—

Height, feet	0	5,000	10,000	15,000	20,000	25,000	30,000
Density	1.0	.869	.714	.613	.527	.444	.360
B.H.P.	200	171	135	111	90	73	58
B.H.P. as % of ground B.H.P.	1.0	.855	.675	.552	.450	.365	.290

Since the resistance to the motion of an aeroplane diminishes directly as the air density, other things being unchanged, the level speed should only diminish slightly with an increase in height. This diminution in speed is, however, rendered more pronounced by the fact that the angle of incidence of the planes requires to be increased in order that they may support the same weight in air of reduced density, and this increases the head resistance.

The climbing speed of the aeroplane is reduced in a much greater degree, since the energy to be expended in lifting the dead weight of the machine through a given height is independent of the density and remains constant at all heights; and at some definite height, depending on the design of the aeroplane and the power of the engine, the latter is only sufficient to overcome the head resistance when flying level at the minimum safe speed of the aeroplane with the increased angle of incidence of the planes, without leaving any surplus lifting capacity. This height is termed the "ceiling" of the plane.

Any device which would enable the power of the engine to be maintained at height would not only increase the level speed, but more especially the rate of climb and the height of the "ceiling."

Three such devices have shown promise. In the first the engine is fitted with differential pistons. Air is drawn into the space between these on the outward stroke of the engine, compressed on the return stroke, passed through a cooler, and forced into the cylinder through a series of ports uncovered by the piston slightly before the end of the suction stroke. By this method the weight of mixture in the cylinder is increased. The degree of supercharging may be adjusted by a regulating valve so as to keep the power constant over a range of heights up to about 10,000 feet. This scheme has not as yet been very successful owing mainly to mechanical defects.

In the second system a centrifugal blower is geared to the engine. The discharge from this is passed through the carburettor on its way to the cylinders which are thus fed with mixture under an increased pressure. The system is, of course, an added complication and involves the maintenance of very high-speed gears and bearings. As the induction system is under pressure, any leaky joints will derange the operation of the engine, and lastly, since the speed of the blower is constant at constant engine speeds, the amount of supercharging falls off with height, while, near the ground, air must be blown to waste through a bypass valve.

In the third system the engine exhaust is discharged through a single-wheel high-speed impulse turbine of the Rateau type. This turbine is direct coupled to a centrifugal blower feeding the carburettor, and delivers sufficient air to the engine to maintain its power at all heights up to about 15,000 feet. This method is partially automatic in that if the pressure in the induction pipe is maintained constant, the pressure of the exhaust gases will be constant, and since the pressure on the exhaust side of the turbine diminishes with height, the pressure available for driving the turbine increases with height to an extent which compensates for the increased demand for power by the blower. A valve for bypassing the whole or part of the exhaust gas directly into the atmosphere is provided to enable the output from the blower to be regulated.

Here also the induction system is under pressure. The weight complete for a 200-H.P. installation can be cut down to about 60 lb. and at 15,000 ft. the gain in power is about 80 H.P. for an expenditure of only 0.75 lb. per H.P. thus gained.

The increased complexity of the installation, the work thrown on the pilot, and the risk of breakdown will all retard the introduction of such schemes. Moreover, the additional weight may alternatively be devoted to increasing the size of the cylinders, leaving the crankcase and crank-shaft, etc., sensibly unaltered. Such a "light" engine would not withstand being opened out fully near the ground, and special precautions would require to be taken to prevent this happening. At height, however, it could be fully opened up, and the increased power corresponding to its increased cylinder diameter taken advantage of. Such a unit has the advantage of simplicity. Many of the latest and most powerful engines are really in a modified

degree "light" engines, in that they cannot be run for more than a very few minutes "all out" near the ground.

Other methods of reducing the drop in power with height are possible. One such method is to design the engine with a compression ratio too high to permit of ground operation, and to reduce this near the ground by a cam giving a late-closing to the inlet valve. As the height is increased the inlet valve would be closed earlier in the stroke until, at some predetermined height, normal timing would be attained. A second method which has been suggested consists in admitting a proportion of cooled exhaust gas to the cylinder with the working mixture. This reduces the tendency to detonation, and enables a higher compression ratio to be adopted than would otherwise be possible. As the height increases the proportion of exhaust gas would be reduced, until, at the predetermined height, the engine would be working on a normal mixture.

**Engine Starters.**—The operation of starting an aeroplane engine by swinging the airscrew by hand has always been dangerous, and to remove the necessity for this, several types of self-starter have been devised. An electric motor geared to the crank-shaft through a clutch achieves this, but the number of starts possible with one charge is limited by the accumulator, and the weight and bulk of the installation restrict its sphere of usefulness. A compressed-air starter is lighter. Here a high-pressure cylinder supplies air to the correct cylinders by means of a distributor operated from the crank-shaft of the engine.

The most usual starting system consists of a supplementary magneto placed in the cockpit and rotated by hand by the pilot when the crank-shaft has been brought into the correct position. For success one or more of the cylinders must contain an explosive charge and therefore the crank-shaft is rotated slowly by hand, drawing a charge of petrol vapour from the carburettor as in normal operation. The plan is, however, unsatisfactory in cold weather, and starting is facilitated by admitting coal gas or hydrogen into the induction pipe from a small container, while the crank-shaft is being rotated.

One modern device, still (1921) in the experimental stage, consists of a small two-stroke single-cylinder engine which is started by hand and drives a compressor which draws an explosive mixture from its induction pipe and forces this through a distributor into the appropriate cylinders of the main engine. This charge is then fired in the usual way.

**Future Development of the Aero Engine.**—The development of the aero engine must increase its reliability, its useful life, its efficiency and its output in horse-power per unit weight, especially at height. Experience gained in the operation of existing types, by a process of survival of the fittest, slowly leads to the elimination of those details in design which are in the main responsible for breakdowns. The reduction of bearing loads and the improvement in bearings, increased perfection in balancing, better design of valve springs and of valve gears, of pistons and piston rings and of lubrication systems, will all add to the useful life, while improvements in carburation, in cooling and lubrication, induction systems, and in sparking plugs, will lead to increased reliability of operation. Efficiency will be enhanced mainly by such modifications in cylinder design or by the use of such fuels as will admit of higher compression pressures.

It seemed possible in 1921 that the Diesel cycle might be developed for aero-engine work, and the Junker engine of this type was said to have attained a fairly advanced stage of development in Germany. In view of the heavy cylinders required a sufficiently light Diesel engine, however, appears to be very difficult of attainment. Failing this, the direct injection of fuel into the cylinder during the suction stroke, using moderate compression ratios, may have possibilities. This is a modification of the method used in the early Antoinette engine, where fuel was injected by a pump into the inlet pipe of each cylinder. The method has the advantage of eliminating the carburettor and induction system and, in theory, of enabling a uniform mixture to be given to all the cylinders. Promising experiments on single-cylinder engines were in progress in 1921.

Outside existing designs in 1921 there appeared to be scope for an engine working on the two-stroke cycle, and for a double-acting line engine with cylinders in tandem. It is true that attention had already been paid to both these types without, as yet, successful results. Still, many of the initial difficulties had been surmounted, and there was every reason to hope that a successful design would ultimately be evolved. Such an engine would have excellent prospects of fulfilling the ideal conception of 7 lb. per B.H.P. which is at present the dream of the aero-engine designer. In view of the immense progress in the design of aero engines during 1919-21, it seemed probable that the aero engines of the future might well show as much improvement as those of 1921 did as compared with the machinery to which the early fliers entrusted their lives.

(A. H. G.)

## VI. AIR NAVIGATION

**Historical.**—Navigation is the art of selecting the course which a craft should take in order to proceed from any one position on the waters to any other. For guidance in the building-up of air navigation centuries of experience of the sister art of

sea navigation may be drawn on, and much of this experience is capable of direct application to the air. The earlier forms of marine navigation were of a rudimentary type and would now be included in the general term "piloting." Whenever they could manage to do so the primitive sea voyagers were careful to keep in sight of the coastline, so that even a rough map sufficed to enable the position of the ship to be noted. The great voyagers of the middle ages were bolder and depended no longer on mere piloting methods; then it was that scientific navigation had its birth. The compass came into use in Europe about the 14th century, and by its means, combined with a rough measurement of the speed of the craft through the sea, it was possible to keep a reckoning on the chart—called a "dead reckoning," or briefly D.R.—of the position from day to day. This allowed nothing for drift due to tides or currents or leeway, but since in the early voyages these were quite unknown in amount no allowances could be made. Experience showed that the D.R. position thus obtained was often considerably in error, and some check upon it became very necessary. For this the simple cross-staff and the astrolabe were employed. With these instruments a rough measurement of the altitude of the sun at midday, or of the pole star at night, enabled the latitude to be determined to perhaps half a degree, or 30 nautical miles. But a simple latitude observation like this did not suffice to ascertain the ship's position, since it merely gave the information that it must lie somewhere on an east-west line drawn so many degrees N. or S. of the equator. If the course were N. or S., this measurement gave the run, but no check on the estimated course; whilst if the course were E. or W., the latitude measurement gave no information as to the run. Later on, when better instruments were available—the introduction of the Hadley sextant in 1731 marked a very real advance—methods were adopted to enable longitude as well as latitude to be measured, but the necessary calculation of lunar distances was troublesome, and it was not until the perfection of the marine chronometer in the latter half of the 18th century that it became open to the average sea navigator to work out his longitude as well as his latitude, and so obtain a check on both run and course.

Experience with air navigation has followed a generally similar path; compressed of course into a very few years. When air craft were first navigated they followed piloting methods only; the earth was continuously, or almost continuously, in sight, and the position from time to time was ascertained by the recognition of landmarks, or, where these were scarce, by a system of dead reckoning based on the compass course and the speed through the air. Here, however, arises the great difference between sea and air conditions. Currents in the sea rarely exceed a few knots, but in the air are quite commonly of 20 knots, velocity, and may be even four or five times as much; moreover, whilst the former may be charted the latter cannot. This would tend to make air navigation the more difficult, but its effect is mitigated by the fact that the air ocean has the great merit—for this purpose—of being transparent (except for occasional cloud sheets) and of enabling the direction and course of air currents to be measured by watching the apparent motion of objects on the earth's surface. A wind of 50 knots opposing an aircraft having a speed through the air of 100 knots will reduce its speed over ground by one-half, while if favouring it will cause the ground speed to exceed the air speed by 50%; neither, however, will cause any apparent sideways drift of the craft. If, in either of these cases, the speed over the ground be measured in some convenient way, it is possible to determine both the velocity and direction of the air current, i.e. the wind. A similar but slightly more troublesome measurement gives the wind velocity, and direction, when the flight is oblique to the wind. This ability is not shared by the sea navigator, who cannot see the bottom of the ocean on which he sails, and has instead to assume the accuracy of the information given on his charts and in his sailing directions.

The fact that an aircraft, when flying with the wind, may have a ground speed of as much as 150 to 200 knots, makes it essential

to determine the position with rapidity. An observation which took 10 minutes to reduce would afford information of a position some 30 nautical m. to the rear. Hence speedy methods are essential; and fortunately—owing to the absence of aerial rocks and shoals, and the extensive field of view—much less accuracy of position-finding is required in the air than at sea. An accuracy of determination of 10 m. suffices for almost all air purposes; whereas the sea navigator aims hopefully at an accuracy within a mile or less.

*Dead Reckoning.*—Hakluyt, recording in 1580 "instructions and notes very necessary and needful to be observed," points out that "in keeping your dead reckoning, it is necessary that you do note at the end of every four glasses what way the shippe hath made (by your best proofes, to be used) and how her way hath bene through the water, considering withall for the sagge of the sea, to leewards, according as you shall finde it growe. Doe you diligently observe the latitude as often, and in as many places as you may possible; and also the variation of the compasse. . . ." These instructions, so necessary and needful to be observed at sea, are for air navigation not less so. But in the latter case special difficulties arise. The course over the ground is determined by the apparent motion of objects on the earth relative to the fore-and-aft line of the craft; but owing to the rolling, yawing and pitching of the latter, and of all instruments carried upon it, such measurements are far from simple. However straight the pilot may try to fly he will yaw slightly from side to side, and this will cause the flight path to be more or less sinusoidal, with an accompanying lateral acceleration tending to cause the machine itself, and all instruments fastened to it, to roll periodically to port or starboard. This will cause any objects below the craft to appear to follow an oscillatory path instead of a straight line, and so make the determination of the angle of drift much more difficult. Nor is it possible to surmount this obstacle by making the observing apparatus pendulous in the hope that it will remain vertical. The lateral acceleration due to the slightly curved path will cause the centre of gravity of the pendulous mass to seek a position such that the moments about the point of support of the weight will balance; in other words, the instrument tends to set itself not to the true vertical but to the "apparent vertical" given by the resultant of the gravitational and the lateral acceleration. If the pendulous instrument has a substantial amount of inertia, it will not have time to pick up this direction before the aircraft will have entered on a fresh part of its sinusoidal path corresponding to a fresh position of the apparent vertical. The instrument therefore continually hunts the apparent vertical, but is always in arrear to the one side or the other. It may appear that by making the inertia sufficiently great the motion of the instrument would be so slow and so slight as to be negligible, but calculation shows that unless gyrostatic forces, with their attendant complication, are brought into play it is not possible, within the necessary limits of dimensions of the craft, to achieve this. These ever-present oscillations are of great importance in the study of aircraft instruments. Not only is the apparatus for measuring the angle of drift of the ground affected by them, but equally any apparatus for getting a reading of the ground speed, and, by no means least, the magnetic compass itself. Compasses fitted to ships usually have a period of oscillation much longer than the period of roll of the ship, hence the compass has not time to be very much disturbed by such movements. In aeroplanes, however, the period of roll is longer and the early types of aircraft compass by an unlucky coincidence had just about the same period, hence resonance was a frequent occurrence, and wild oscillations of the compass needle were all too frequently reported. Later on the cause of the phenomenon was recognized and a remedy was found.

That a magnetic compass points magnetic N. instead of true N. gives rise to the correction called "variation," and this applies equally to sea and air craft. Variation charts are equally available and no difficulty is presented. With the correction known as "deviation" due to the magnetism residing in the structure of the craft itself, air conditions are simpler than those at sea, in that the masses of magnetic material near the compass position are much less in amount; but on the other hand the value of the deviation on each point of the compass is rather more troublesome to determine and much more likely to vary with the life history of the craft itself.

The measurement of the speed through the air fortunately presents none of these difficulties since the forces produced by the relative air stream are dependent only on velocity and air density, and the latter being known for any given altitude of flight it is possible to obtain a measure of velocity through the air free from any complication.

Except for flying-boats engaged on anti-submarine patrol scarcely any aircraft prior to the end of the World War had need to employ navigational methods of flight: ordinary piloting sufficed for their journeys. The work of the flying-boat patrols, however, required meticulous care in navigation since their duties carried them far out of sight of land and it was imperative that they should make a landfall before the petrol supply ran out. The method employed was dead-reckoning navigation carried out with that care which the risk

of failure made necessary for all employed on this arduous service. That so few flying-boats were lost on such patrols says much for the care with which the instruments were attended to and the skill with which their indications were heeded. An error of only two degrees in the course made good would throw out the position by over 3 m. in each 100 flown. The consequences on a misty day for an aircraft trying to make, say, the Scilly Is. base can be imagined. There were then no facilities for astronomical navigation, and dead reckoning had to be relied upon.

Not only had the flying-boats on war service to be navigated but the pilot and observer had also to "navigate" a bomb to its desired target. Since a bomb, or any other heavy body, maintains the course and speed of its carrier aircraft substantially unaltered during its fall to sea level, the sighting problem is the same as the dead-reckoning navigation problem. In fact, one observing instrument can serve both purposes. The horizontal motion of the bomb is compounded of the wind velocity and the air speed of the craft. The distance it will travel horizontally will be the product of the resultant of these two velocities and the time taken to fall from the height at which the aircraft is operating. This then must be the horizontal distance of the craft from its target at the moment of release and the line of attack must of course be that of the course being made good. The angle ahead of the vertical which the target subtends at the moment of release is called the sighting angle, and obviously it will vary with the direction in which the target is attacked unless the wind velocity happens to be zero. This requires that the instrument should be set for height, air speed, wind velocity and wind direction, and further that it should make automatic provision for the right combination of these elements for any direction of attack.

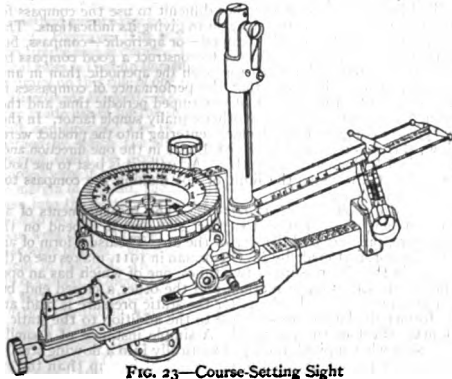

FIG. 23—Course-Setting Sight

The best known instrument for doing this is the course-setting sight shown in the illustration (fig. 23), and much used on flying-boats; in its navigational use it enables the velocity and direction of the wind to be measured whilst in flight, and it indicates the course to be steered for any given track, and the time taken in flying any desired distance in that direction. Towards the end of the war the French made some use of navigational bomb sights, and the United States Government had a large number constructed, but so far as is known no such efforts were made elsewhere.

For D.R. navigation on land aircraft use is often made of an instrument called an aere bearing plate. This was an adaptation of a manne bearing plate, or pelorus, having a transparent centre to admit of vertical observations of the ground, and having one or more longitudinal rods or wires which could be aligned parallel to the apparent earth flow so as to enable the drift angle to be read off. A graduated height bar also permitted the ground speed to be measured by noting the time taken for an object on the earth to pass through the vertical angle corresponding to a distance of flight of half a mile, or other convenient distance.

**New Navigational Instruments.**—One of the first instruments known to have been used for the determination of latitude in maritime navigation was the astrolabe. This device consisted of a pendulous disc graduated round its circumference in degrees and carrying at its centre a rod fitted with back and fore sights the inclination of which to the horizontal could be read off on the degree scale. A sight on a star would therefore give a measurement of its altitude. The use of a pendulum or "plumb bob" is, of course, a familiar way of obtaining a vertical line, but it suffers from the disadvantage that it no longer indicates truly if its point of attachment is not kept still. On board ship the point of support is necessarily in general motion and in consequence the pendulum continually oscillates: its average position still gives the vertical, but it is a tedious business to find what the average position really is. Seamen turned, therefore, to the visible horizon as a more satisfactory datum from which to measure the altitude of heavenly

bodies; the early cross-staffs were inaccurate, but a nearly perfect form of instrument for this purpose was discovered in the Hadley sextant of 1731. It depended on the very important fact that if a beam of light be reflected from two plane mirrors in sequence, the total angle through which the beam is turned depends only upon the angle between the two mirrors and not on the angle between the rays of light and the mirrors themselves. Thus, if the two mirrors are fixed at an angle of  $40^\circ$  to one another, the angle through which the ray of light will be turned after the double reflexion will be exactly  $80^\circ$ ; if this reflecting system be now used to view a star having an angular elevation above the visible horizon of  $80^\circ$  then the star will appear to be "brought down" to the horizon and its apparent position will not be affected, however much the frame carrying the two mirrors may be rocked in a vertical plane. It will easily be seen that for use on a rolling platform, such as the deck of a ship, this is a most valuable property. The seaman will see the horizon rising and falling relative to the ship, but the image of the star will rise and fall with it. If the two images only came into coincidence when the deck was level, the instrument would be useless. It is the fact that star image and horizon appear to move together when the ship rolls or pitches which makes the sextant the valuable instrument it is. Inasmuch as the pitching and rolling of an aircraft is sometimes just as bad as the pitching and rolling of a seacraft, it might be thought that the Hadley sextant would equally be of use in the air. Indeed, the instrument is equally available, but the horizon is not. At 10,000 ft. height the horizon is about 90 m. away, and unless the day is exceptionally clear there will be sufficient mist to prevent so distant a horizon being visible as a clear line. If the horizon has therefore to be abandoned as a datum line, it becomes necessary to fall back once more on the method of the mediæval astrolabe and to employ plumb-bob methods of obtaining the vertical. This, of course, has the great disadvantage that it is only the average of a number of such observations that can give the true answer.

There is, however, a half-way house, though not a good one. Although the true horizon may be invisible there will often be false horizons given by the upper surface of cloud layers or banks of mist. These false horizons are not so far below the level of the aircraft as, in the sea, hence their distance is much less and the line of separation between cloud level and sky is often sufficiently sharp to be of use. The great drawback is, however, the absence of definite knowledge of the height of such cloud levels, and therefore of their value as datum lines for sextant observations. A wrong guess at the height may give a totally false value to the sun's altitude, and therefore to the position line deduced from it. Attempts have been made to avoid such errors by assuming that the false horizon on the port side is of the same altitude as that to starboard, and then, by taking a point half-way in between as the zenith, to make all measurements from that as datum. This is correct just as often as the two horizons do happen to be of the same height; but it does not appear that this is always the case, nor in fact is a second horizon always visible, and at night time neither the one nor the other. Moreover, such level cloud or mist layers can only be expected when the temperature lapse rate is small and the air is very stable. On very many occasions these conditions do not hold, the air is frequently "bumpy," and the cloud masses heave and tumbled. Speaking generally, the conditions in which large flat cloud sheets extend are conditions favourable to navigational measurements, and they are also the conditions in which accurate knowledge of position is most essential. Such conditions arise when the temperature falls but slowly with altitude. When this lapse rate (as it is called) is much lower than the  $10^\circ\text{C. per km.}$  which marks the condition of instability, there is little atmospheric turbulence; and the aircraft is comparatively steady; even a plumb-bob instrument is then a convenient method of making measurements. A spirit level is of course a form of plumb-bob, in that the bubble is a kind of inverted "bob," which tries to get as high up as possible instead of as low down. Such levels have long been used in inclinometers for surveying, whence the well-known "Abeey level." They suffer, however, from the disadvantage that when the instrument rocks the image and bubble move in opposite directions. No such device could be a success in the air, and it is necessary to incorporate the double reflexion method—or its equivalent—of the Hadley sextant. This has been done by the staff of the Royal Aircraft Establishment, Farnborough, in England, and by Prof. Wilson in America.

The principle of action of the R.A.E. instrument is shown in fig. 24. In this instrument—known as the R.A.E. bubble sextant—the vertical is given by the position of the bubble in a spherical level, capable of being illuminated at will by a little electric lamp. The eye may take up either position (1) or position (2). The former is best for star or planet observations, and the latter for those on the sun, though theoretically there is no reason why either position should not be used for all observations. It is a matter of convenience which is used; a star is more easily identified and held in view by the method of direct vision, whilst for observations of the sun there is no risk of confounding it with any other heavenly body, and it is much more comfortable to the eye to look downwards and so avoid the glare of the sky in the neighbourhood of the sun. The lens is chosen to have a focal length equal to its optical distance from the bubble, and since the curvature of the upper surface of the latter is



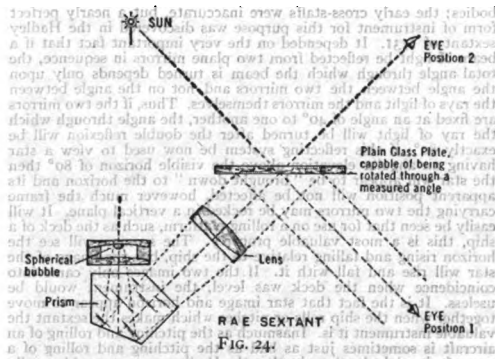

carefully chosen to be equal also to this distance, the bubble will remain in focus and will appear to move with the sun or star if the instrument should rock in the hand.

**Gyrostatic Horizons.**—When sextant observations are made at a ground station it is best to employ an artificial horizon, usually in the form of a bath of mercury. The sextant is then used to measure the angle between the heavenly body itself and its image seen in the reflecting surface of the mercury; half this angle is the angle of elevation of the body above the horizontal. Such a method is inapplicable to an aircraft for two reasons: first, that the vibration would cover the mercury surface with ripples and cause it to reflect a shimmer instead of a definite image; and secondly, that the acceleration forces would act on the mercury and cause its surface to tilt in one direction or another. For this reason use has sometimes been made of a little gyrostal spinning on a pivot and carrying a small circular mirror fixed at right angles to the axis of rotation. If this gyrostal accurately kept its axis vertical the little mirror would form a convenient substitute for the mercury bath. But it also is subject to the disturbing effect of acceleration forces, and is thereby deflected more or less from the desired position. Its behaviour in this respect, is, however, much in advance of that of a simple pendulum or bubble; although since it is a rotating body it has the double disadvantage of requiring power to drive it, and of being adversely affected in its performance by the inevitable wear of its pivot. It is still uncertain whether a sextant using a bubble or a little gyrostal will in the long run prove the more suitable for air purposes. Gyrostatic means of measurement are, however, of much importance for air navigation, and the first application on a wide scale is that of the gyrostatic "turning indicator." In this device a gyrostal is spun in bearings so that its axis lies normally in a horizontal plane. If then the framework containing the bearings is turned about a vertical axis—due to the aircraft carrying it turning to port or starboard—the gyrostal will tend to turn itself about an axis perpendicular alike to that about which the forced turn occurs, and that about which the gyrostal is itself rotating. This effect is called "precession" and the couple brought into play is called the "precessional couple"; this couple is caused either to compress or to wind up a spring and in so doing to move a pointer, the indications of which give a measure of the degree of rapidity of the turn, and whether the direction is to port or starboard. Such turning indicators are invaluable when flying in cloud, mist or fog. Without them a pilot tends to lose all sense of direction, and the indications of the compass, which might be thought a sufficient safeguard against such uncertainty, are in some cases so affected by the large and sudden acceleration forces brought into play as to be quite misleading in their indications. The reason for this will be dealt with at greater length in what follows. The gyro turning indicator was first employed for measuring the rate of roll of ships (apparatus for this purpose was made both by J. B. Henderson and H. E. Wimperis prior to the World War) and its use on aircraft came in the later stages of the war. In the meantime an aircraft turning indicator due to H. Darwin had been employed; this depended on the static air pressure at the two wing tips being communicated to a differential manometer (air-speed indicator type) and a reading being given whenever the aircraft turned, since in so doing it introduced centrifugal forces which disturbed the balance of the two pressures and so gave a plus or minus deflection of the manometer needle. The instrument works well, but needs more attention than the gyro device.

Gyrostals are also used in aircraft as azimuth indicators for experimental or test purposes; they may some day be used as part of a gyrostatic compass, but the necessary weight limit will make their introduction for this purpose a matter of some difficulty.

**Magnetic Compass.**—The design of the magnetic compass as applied to aircraft has in late years undergone a marked improvement. Quite early tests showed that the compass should be a liquid one, and that—to avoid the effect of engine vibrations—the pivot should be above the cup. But most of the early compasses had

periodic times of oscillation about equal to those of the airplanes on which they were carried, and resonance in vibration took place, so that when the airplane rolled even a little, the compasses oscillated through considerable angles. Moreover, such short compasses give false readings of a turn when flying on any course between N.E. and N.W. The simplest explanation of this phenomenon (first given by Keith Lucas at the Royal Aircraft Factory in 1915) is that since in these latitudes the north-seeking end of a balanced magnetic needle tends to dip downwards it is customary to add a weight to the south end in order to keep the compass card horizontal. When an airplane flying N. begins to turn to starboard this little weight is acted upon by a centrifugal force acting from E. to W. and hence tends to turn the compass card also to starboard. An ideal compass would remain pointing exactly N., and the turn of the aircraft to starboard would be noticed by the apparent motion of the lubber mark from N. towards E. round the compass card; but if the card is also rotating in the same direction, and at perhaps a greater angular speed than the airplane, the lubber mark may appear to move towards the W., giving the false impression of a turn to port. Hence a flier unable to see the ground may infer quite wrongly that he is turning to port when he is really turning to starboard. In order, as he thinks to correct his turn, he tends still more to starboard whereas he really should have turned to port. The compass therefore fails to keep him on a straight course. Many of the earlier types of compass had this defect, but by making the compass period very much longer (as suggested by Keith Lucas), or by making the damping friction very much greater (as suggested later by Campbell & Bennett), the notherly turning error was either eliminated or greatly reduced. There is, however, a practical limit to the length of the periodic time, since if this be too great it becomes difficult to use the compass for ordinary navigation; it is too sluggish in giving its indications. This limit also concerns the highly damped—or aperiodic—compass, but not in the same degree. It is easier to construct a good compass by making the degree of damping approach the aperiodic than in any other way. Theory indicates that the performance of compasses is governed more by the product of undamped periodic time and the damping coefficient than by any other equally simple factor. In the early types of compass both elements entering into the product were too low; this was remedied by Keith Lucas in the one direction and by Campbell & Bennett in the other. Actually it is best to use both means subject always to the limit of not making the compass too slow in its movements.

**Air Speed and Height Measurements.**—The measurements of air speed and height are linked together, since they both depend on the temperature, pressure and density of the air. The usual form of air speed indicator, first made by M. O'Gorman in 1911, makes use of the difference in the air pressure in two tubes, one of which has an open end facing the direction of motion, and the other a closed end, but with a hole in the side. In the latter the static pressure is read, and in the former the larger pressure due to the addition to the static of the kinetic effect of the air speed. A simple instance of a similar effect is seen when a plank is dipped vertically into a flowing stream; the surface facing up-stream will be wetted higher up than the one facing down-stream. The difference in height is a measure of the velocity—or rather of the square of the velocity—of the stream. In the case of a compressible fluid like air it also depends on its density. In fact, the reading of the air-speed indicator is proportional to the product of the density of the air, by the square of the velocity through the air. Since such instruments are always calibrated so as to read correctly at sea level, it follows that the "indicated" air speed will always be less than the true air speed at altitude. Thus an aeroplane travelling at 140 m. an hour at a height of, say, 21,000 ft. will only be credited with 100 m.p.h. on the air-speed indicator. Such indicators are therefore sometimes provided with circular calculators around their circumference to enable the true air speed to be read for navigational purposes. For aerodynamic purposes such corrections are quite unnecessary since the forces due to air pressure acting on the wings, the fins, the tail and all other surfaces will also be proportional to the product of air density by the square of the speed, and an instrument like the air-speed indicator which gives a reading proportional to this product is, for this purpose, ideal and needs no correction. So that, although for purely navigational requirements it might be thought advisable to introduce a type of air-speed indicator giving true air speed, such action would be disadvantageous from the purely flying point of view. Hence it is best to retain the present instrument and to add for navigational purposes a circular calculator to effect the conversion. The case of the aneroid is not entirely parallel, but it also needs a supplementary device if the true height is to be read. Almost all altimeters in use are based on the pre-flight aneroid in which the trade convention was to assume everywhere an atmospheric temperature of 10° C. Although this is not widely out for the average surface temperature it is manifestly most incorrect at a height, since on the average the temperature falls by about 6° C. for every km. (3,281 ft.) of ascent. Thus at 7 km. (23,000 ft.) the mean temperature of the atmosphere would be about 2° below the assumed steady level of 10° C.; the difference of about 7% leading to an over-estimate of height by the same amount. This is corrected by reading the temperature at height on a strut thermometer and using a circular calculator (the A.M.L. height computer)—as in the case of the air-speed indicator—

to give the true result. For surveying work an accurate measure of the height is of special importance.

**Reduction of Astronomical Observations.**—The traditional method of maritime navigation is to employ logarithmic tables for the solution of the spherical triangle. The problem is: given the declination of the heavenly body, the latitude of the assumed position and the hour angle at the moment of observation, to determine the corresponding altitude of the heavenly body. The difference between the altitude thus calculated and the corresponding value as measured with a sextant gives the "intercept," and the azimuth its bearing; this suffices to enable the "position line" to be drawn in the usual way.

To make this calculation by means of logarithmic tables is simple enough on board an airship, but is not easily performed in an aeroplane. Nor is the degree of accuracy to which the existing tables are worked out necessary for air navigation. A method, which was tried in a Handley Page machine, was to use the rectangular nomogram devised by d'Ocagne, but it was found that within the limits of space available it was not possible to draw the diagram to a sufficiently large scale to ensure the final answer being accurate within the necessary one or two minutes of arc. (It is true that the determination of position to within 10 m. easily suffices, but there is not infrequently an error of this amount in the sextant observations themselves; and to these unavoidable errors of observation it is not desired to add any larger error due to the process of reduction of more than one or two miles.) Trial was next made of the ingenious method suggested by Veater of employing a Mercator projection of the sphere and using certain curves drawn thereon to solve the spherical triangle by the equivalent of a solution of the sphere. This method gave, in small compass, a means of attaining the accuracy desired; but it was difficult to use the curves without eye strain, and the method eventually gave place to the cylindrical slide rule devised by L. C. Bygrave. The whole procedure is by his last means made both simple and accurate. The advantage of the spiral scale of cylindrical rules is that an immense length of scale is compactly housed; an accuracy on this rule of one or two minutes of arc is easily attained.

**Directional Wireless.**—During recent years wireless telegraphy has been made use of for the determination of the position of both seacraft and aircraft. The invention followed from the discovery of a method by which the direction from which wireless waves were arriving could be accurately measured. An analogy would be afforded were it possible to determine, from the receipt of ripples at the margin of a pond, the direction of the spot at which a stone had fallen into the water. It was found that if a rectangular coil happened to be placed so as to face the direction from which the wireless waves were travelling, no current would flow in the coil, whilst if the latter were placed "edge on," it was possible to detect an oscillating current in the coil. In intermediate positions, intermediate results were obtained. Once, therefore, a search coil of this kind is mounted on a vertical axis it can be turned until the current is either a maximum or a minimum, and by these means the direction of the sending station be determined. It is true that a station N.E., say, could not be distinguished from one to the S.W., but other considerations usually enable a right choice to be made from these two alternatives. In practice various electrical improvements have been made on this simple circuit but the principle is the same; and it is the results obtained by such means which are of importance to the navigator. The navigator will of course require of the wireless officer that W/T bearings so given shall be "true," and that corrections due to any possible bending of the waves shall have been allowed for.

There are two methods by which "directional wireless" (as it is termed) can be employed. The first and simplest is by having suitable search coils mounted in wireless beacons ashore. Two or more of such beacons take note of the direction of the calling aircraft, and communicate with each other so that one of them can plot on a map the several bearings which, by their common point of intersection, determine the position. This is then communicated to the aircraft. The plan has the double advantage that the aircraft is forced to disclose its position, and that the number of messages sent to the air is thereby increased. The alternative is to mount the search coil on the aircraft, and for the latter to determine the bearings of two or more sending stations, and to do its own position-plotting on the chart. The latter alternative is usually preferred, but it suffers from the difficulty that the bearing of the wave is not infrequently altered immediately prior to receipt by the influence of the many flying, and other, wires forming part of the structure of the aircraft. These are called quadrantal errors, and they correspond to the errors which would be obtained in magnetic compasses if deviation were not allowed for. A difficulty common to both methods lies in the bending of the ray's direction when crossing a coast line, or the boundary of day and night—such effects need to be allowed for. The plotting of wireless bearings, whether in the aircraft or ashore, requires care. If, as is usual, a Mercator chart is employed, it has to be borne in mind that straight lines on such charts are not great circles, and since the waves travel along the latter (except for the disturbances above mentioned) it is necessary to draw the path of the waves by means of a certain curve, the bending of which will depend on its distance from the equator. The proper methods of doing this are in use, but the best method (following Veater) is to make use of the Litrow projection of the sphere (more familiarly known as the "Weir diagram").

Much work has still to be done before it can be determined how accurately the position of an aircraft can be found by means of directional wireless. But it has a great use apart from position finding, since it enables a straying aircraft to fly back to its parent ship by flying "home" along the wave path. Its path may not be a straight line, and it may take some time to make the flight, but if persisted in it is bound to bring the craft home sooner or later.

**World Flights.**—The famous world flights of 1919 and 1920 were the transatlantic crossings by the American flying-boat, NC4, by the Vickers-Vimy aeroplane, and the rigid airship R34 (not forgetting the gallant attempt of the Sopwith aeroplane); the flight to Australia by a Vickers-Vimy aeroplane, and the several attempts to fly an aeroplane down the length of Africa.

In the case of the Australia flight the coast line was usually followed and methods of air pilotage, as distinct from air navigation, sufficed. The African flights were in part over uncharted territory, and pilotage alone did not suffice; both there and, of course, in the transatlantic flights the course was steered by navigational methods. In the case of the R34 the operations were carried out by officers accustomed to the navigation of naval ships, and in so roomy a craft the work was much more easily arranged than in the more compact aeroplanes and flying-boats. Comm. Mackenzie Grieve, the navigator of the Sopwith, stated that even in his tiny aeroplane he navigated by celestial observations and found that his position, as given by his observations of the stars, when picked up after the forced landing in the sea was "practically correct."

The instruments available in 1921 for navigation were much more satisfactory than those in use prior to 1920. In future world flights the determination of position, course and speed will not only be simpler and more speedy, but will also be very much more accurate than anything hitherto known in the history of air navigation.

**BIBLIOGRAPHY.**—S. F. Card, *Navigation Notes and Examples* (1917); and *Air Navigation Notes and Examples* (1919); J. E. Dumbleton, *Aerial Navigation* (1920); H. E. Wimperis, *Primer of Air Navigation* (1920); Hawker and Grieve, *Our Atlantic Attempt* (1920). (H. E. Wi.)

## VII. CONTROL OF AIR TRAFFIC

The pre-war legislation of individual States generally presumed sovereignty of the air, but the doctrine was not finally accepted until the World War. Thus in 1911, at the Madrid session of the Institute of International Law, a resolution was passed that "International aerial circulation is free, subject to the right of States to take certain steps, which shall be fixed; to ensure their security and that of the persons and property of their inhabitants." This principle was modified in the Report of the Committee on Aviation of the International Law Association in 1913:—

"It appears to the Committee impossible to contend that according to existing International law the air space is free, nor do they think that States would be willing to accept or to act on that part of the law. But they are of the opinion that, subject to such safeguards as adjacent States may think it right to impose, aerial navigation should be permitted as a matter of comity."

Though in some quarters the assertion of state sovereignty only up to some prescribed height was advocated, individual States, and among them Great Britain, asserted, mainly for military reasons, their right to close their atmosphere absolutely (*usque ad coelum*) to the aircraft of other States. It was the conflict of opinion between the British and German delegates, as to the right of each State to the exercise of control and jurisdiction in the air space over its territories, that prevented the completion of an International Convention by the conference held in Paris in 1910. By the first British Aerial Navigation Act (1911) power was taken to prohibit the navigation of aircraft over prescribed areas. In the Act of 1913 this power was extended for the purposes of the defence or safety of the realm to the whole or any part of the coastline of the United Kingdom and territorial waters, while the Statutory Rules and Orders of that year limited the landing areas for aircraft coming from any place outside the United Kingdom to a comparatively few strips of coastline, and forbade foreign naval or military aircraft to pass over or land within any part of the United Kingdom except



with express permission. By a French decree of 1913 the circulation in France of foreign military aircraft was forbidden, and the draft Franco-German Agreement of 1913 practically admitted the principle of the sovereignty of the air by allowing each country the right of making such regulations as it pleased for flights above its own territory.

From the beginning, therefore, air sovereignty and air legislation were influenced by a predominantly military conception of aviation, and, on the outbreak of war, the doctrine of the freedom of the air was doomed. In the words of the Civil Aerial Transport Committee in 1918: "Since the outbreak of the war sovereignty over the air has been generally claimed and, except by Germany, recognized." During the war neutral countries consistently regarded the passage of belligerent aircraft over their territory as an unneutral act.

Pre-war legislation was in spirit and effect distinctly national, and in Great Britain regulations affecting the entry of foreign aircraft from abroad were stringent. In the case of airships a clearance from a British consular officer was required, and in the case of aeroplanes notice had to be sent to the Home Office giving the proposed place of landing, time of arrival, and nationality. Aircraft were forbidden to carry mails or goods chargeable upon importation, and before departure were obliged to report to an officer at one of the prescribed landing-places. Otherwise, with the exception of an Order prohibiting the navigation of aeroplanes within four m. of Charing Cross and of a number of small areas over which flying was prohibited on military grounds, there was no State regulation of flying, and certification and other safety measures were carried out by the Royal Aero Club, which represents Britain on the *Fédération Aéronautique Internationale*.

A similar state of things existed in France until the passage of the *Aerial Navigation Act of 1913*, which was to a considerable extent based on the draft Convention of 1910, and made the owner of an aircraft responsible for damage to property, provided for the registration, marking and inspection of aircraft, pilots' certificates and log books, and prohibited the transport of foreign merchandise or of national merchandise unaccompanied by papers testifying to its French origin.

The only serious attempt to place aviation on an international civil basis, by the adoption of a code of regulations common to all countries, was the draft Convention of 1910, which dealt with the nationality and registration of aircraft, certificates and licences, the admission of aerial navigation over the territory of foreign States, customs and transportation, and rules of the air. The international aspect of aviation did not, however, completely die with the failure of the Convention to materialize. The Institute of International Law, in its session of 1911, adopted rules distinguishing aircraft as public and private, confining an aircraft to one nationality, *i.e.* that of the country in which it was registered, and imposing identification marks. Another step in international air traffic was the Franco-German Agreement of 1913 permitting the entry of civil aircraft into each country subject to the conditions that machines were provided with navigation licences and distinctive identification marks, that the fliers were provided with proficiency and nationality certificates, and that the requirements of international law and the customs and air regulations of each country were observed.

In England in 1913 the Convention of 1910 was reconsidered by a sub-committee of the Committee of Imperial Defence; and when the advance in flying during the war indicated the great potentialities of aircraft for civil transport, a Civil Aerial Transport Committee under the chairmanship of Lord Northcliffe was appointed by the Air Board in 1917 to consider the whole subject, both from its international and national aspects. It was not, however, until after the Armistice that the first steps were taken by a departmental committee of the Air Ministry to frame regulations for civil flying in Great Britain. Shortly after, the drafting of a Convention governing international civil flying was included in the work of the Peace Delegates at Paris—the coördination of the British proposals therewith being undertaken by Sir Frederick Sykes, and took shape as the International Air Convention, which was signed by the majority of the Allied and Associated Powers on Oct. 13 1919, though up to Aug. 1921 ratification was not yet complete.

The objects aimed at by the Convention are the encourage-

ment of the peaceful intercourse of nations by means of air intercommunication, and the establishment of a broad basis upon which a uniform procedure for the control of air traffic can be drawn up by the contracting States.

The parties to the Convention recognize the exclusive sovereignty of every Power over the air space above its own territory and territorial waters and those of its colonies, and while each contracting State allows freedom of innocent passage above its territory, except over certain areas prohibited for military reasons, to the aircraft of other contracting States, it may not, except by a special temporary authorization, permit the flight above its territory of aircraft belonging to non-contracting States (Article 5).

Every aircraft of a contracting State has the right to cross the air space of another State without landing, subject to following the route fixed by the State, but if it passes from one State into another it must land, if required to do so by the regulations, at an appointed aerodrome. Every State has the right to establish reservations and restrictions in favour of its national aircraft in connexion with the carriage of persons and goods for hire between two points in its territory but is liable to reciprocity on the part of other States. Any aerodrome in a contracting State open, on payment of charges, to public use by its national aircraft, is likewise open to the aircraft of all the other contracting States.

Aircraft engaged in international navigation must be provided by the State whose nationality it possesses with certificates of registration and airworthiness, certificates of competency and licences for the crew, which must be recognized as valid by the other States, a list of passengers, and, if freight is carried, bills of lading, log books and a special licence for any wireless equipment carried.

The Convention forbids the carriage by aircraft, engaged in international navigation, of explosives, arms and munitions of war. All private aircraft, *i.e.* aircraft which are not used for military purposes, or employed exclusively in State service, are subject to the provisions of the Convention.

A series of annexes to the Convention give detailed regulations with regard to the marking of aircraft (Annex A), certificates of airworthiness (Annex B), log books (Annex C), lights and signals and rules of the air (Annex D), pilots' and navigators' certificates (Annex E), maps and ground markings (Annex F), the collection and dissemination of meteorological information (Annex G) and customs (Annex H).

The Convention provides for the establishment of a permanent International Commission of Air Navigation, affiliated to the League of Nations, consisting of two representatives of the United States, France, Italy and Japan, one representative of Great Britain and each of the British Dominions and India, which are deemed States for the purposes of the Convention, and one representative of each of the other contracting States, for carrying out the terms of the Convention and the interchange of information.

Disagreements among States as to the interpretation of the Convention and technical regulations are to be settled respectively by the Permanent Court of International Justice and a majority of votes of the Commission. A State which took part in the war of 1914-9 but which is not a signatory of the Convention may only adhere to it if a member of the League of Nations, or, until Jan. 1 1923, if its adhesion is approved by the Allied and Associated Powers, or after that date if it is agreed to by at least three-fourths of the signatory States.

States which remained neutral during the war have not availed themselves of the Article permitting their adhesion to the Convention, mainly owing to the restriction placed by Article 5 on their intercourse by air with late enemy States. To overcome this difficulty, a Protocol was subsequently added to the Convention permitting certain derogations to Article 5 and authorizing the contracting States profiting thereby to allow, for a limited period of time, the aircraft of one or more named non-contracting States to fly over its territory.

The above Convention of 1919, the charter of international flying, may be regarded as prescribing the minimum control required from contracting States. There is no reason why States should not make their regulations more stringent for their own aircraft in the interests of safety and efficiency. The harmonization of the regulations enforced by the contracting States will undoubtedly form an important part of the functions of the International Commission of Air Navigation.

During 1919-20 a large number of countries, including, among others, Great Britain, France, Belgium, Spain, the Scandinavian kingdoms, Holland, Italy, Switzerland and Germany, passed regulations more or less in accordance with the requirements of the Convention, though in most cases frequent additional Acts or Decrees, embodying modifications in the original regulations, have been found necessary to secure stricter conformity with the Convention. Thus the British *Aerial Navigation Act of 1919*, and the Regulations issued by its authority which were influenced by, but actually preceded, the signature of the Convention were only temporary, and were superseded by the *Air Navigation Act of 1920*.

The Act of 1920 asserts absolute sovereignty over all parts of His Majesty's dominions and adjacent waters, provides for the application of the Convention by Order in Council to internal flying, the regulation of civil flying and the supplementing of the Convention, as necessary, by general safety regulations. It authorizes any steps to be taken for preventing aircraft from flying over prohibited areas or entering the British Isles in contravention of the law, and permits the extension of the provisions of the Act to British Possessions other than the Dominions and India. The Act also provides for the prohibition of all flying, and the taking over of aircraft, etc., in time of emergency; the establishment and maintenance of aerodromes by the Air Council or local authorities; purchase of land; compulsory investigation of accidents; and penalties for dangerous flying. No action lies in respect of trespass or nuisance by reason of the flight of aircraft over any property at a reasonable height above the ground, or the ordinary incidents of such flight, so long as the provisions of the Act and Orders made thereunder are complied with, but where damage is caused by aircraft, damages may be recovered from the owners of the aircraft. The law relating to wreck and salvage at sea applies to aircraft in the same way as to vessels.

**Administration.**—The methods of administration adopted in Great Britain in conformity with the Air Navigation Acts were probably, in 1921, in advance of those in other countries, but they might be regarded as typical of what would be required, at least in the near future, before aircraft could be operated by companies or private individuals in accordance with the terms of the International Air Convention. Their essential points are given below.

(i) **Registration of Aircraft.**—Every aircraft must possess a certificate of registration, which lapses on change of ownership.

(ii) **Licensing of Personnel.**—For a private pilot's licence the Royal Aero Club certificate is accepted as a certificate of competency, the Club having agreed to bring their tests for this certificate into line with those laid down in the International Air Convention. A person qualified as an R.A.F. pilot is entitled to a private pilot's licence. For a licence to fly a passenger or goods aircraft for hire or reward an applicant must undergo a medical examination, pass certain practical flying tests and a technical examination, submit proof of reasonable flying experience within the previous six months on the class of machine for which a licence is required, and pass an examination in navigation and elementary meteorology. In the case of applicants who are qualified as R.A.F. pilots the tests are limited to an examination in navigation and meteorology. Licences are issued for six months. There are five grades of licences for navigators. Aerial navigators, fourth-class, are licensed only to navigate civil aircraft over land by day, those qualified for the third-class certificate are licensed to navigate only over land by day or night, whilst those attaining the higher classes are licensed to navigate over both land and sea by day or night. Licences for ground engineers, usually valid for twelve months, are granted for the inspection and maintenance or overhaul of aircraft or engines.

(iii) **Airworthiness.**—In order that an aircraft may receive a certificate of airworthiness, its design, including the design of its components, must be approved as satisfying the requirements of safety in regard to both strength and stability; it must be constructed of approved materials and by workmanship of approved quality, and its engine must be approved.

In order that such certificate may be valid on any particular occasion the aircraft must be examined before flight and be periodically overhauled by a competent person duly licensed; it must be so loaded that its total weight does not exceed a given maximum, and its centre of gravity must be situated within certain given limits. If the application for a certificate is in respect of a "type" aircraft, inspection is carried out by representatives of the Aeronautical Inspection Directorate, and, in addition, such drawings and particulars are required to be furnished to the Director of Research, as will enable him to approve the design. In the case of "subsequent" aircraft constructed by a firm whose inspection is approved, sole responsibility lies with the Aeronautical Research Directorate, the constructor insuring that the conditions governing the inspection of "type" aircraft are applied to "subsequent" aircraft. A certificate of airworthiness is not valid unless the aircraft concerned is regularly inspected by a licensed ground engineer employed by the owner of the machine.

(iv) **Aerodrome Licences.**—The regulations for aerodrome licences are framed to insure that only those aerodromes which are safe for passenger work receive licences.

The dimensions laid down as a preliminary guide for the classification of aerodromes are as follows:—

800 yd. run in any direction,	Suitable for any type of aircraft.
with good approaches, etc.	Suitable for all but the larger types of aircraft, i.e. not suitable for H.P.V. 1,500.
600 yd.	Suitable as permanent aerodrome for aircraft of Avro 504K or similar types.
300 yd. by 400 yd.	

Temporary aerodrome for Avro 504K and similar types.

Any aircraft may use a licensed aerodrome of the appropriate class, subject to the payment of the landing and housing fees approved at the time of the issue of the licence.

**GROUND ORGANIZATION**

(i) **Air Ports.** (a) **Aerodromes.**—The early aerodromes were usually any large, level grass fields, and the first real aerodromes were established in France, England, Germany and America. Their early equipment consisted only of rough sheds for aeroplanes, and fliers carried out at the local smithy or garage such repairs as could not be done on the spot or in their own homes. Repair shops were only available at a very few of the military flying grounds. As aeroplanes became more numerous, workshops equipped with power-driven machinery were established at large aerodromes such as Farnborough and Hendon, and the occupations of "aeroplane mechanic" and "aeroplane rigger" were defined. With the increase of flying, certain rules were laid down for the control of aerodromes; aeroplanes were not allowed to be moved about the aerodrome without ascertaining that they were clear of other craft alighting, and when in the air in the vicinity of aerodromes, were obliged to conform to circuit rules, i.e. machines were made to circle round an aerodrome in one direction, which was indicated by a coloured flag hoisted in a prominent position; and some form of indicator, such as a smudge fire, was used to afford pilots a guide to the direction of the surface wind.

From these simple rules, the complex system of aerodrome control which developed during the World War was built up. While the original principles of aerodrome management remained the same as in 1914, new inventions produced much greater efficiency. With the advent of night flying new methods of visual signalling were adopted (see below); the bucket flares, used at the beginning of the war to indicate wind direction, were replaced by electric lights or the "Money" flare; and a standardized system was introduced to permit of machines leaving and arriving at an aerodrome in quick succession both by day and night.

The results of the experience accumulated during the war in the control of aerodromes were embodied after the war in Annex D of the International Air Convention.

According to the regulations laid down therein, every aerodrome consists of three zones looking up-wind: a right-hand or taking-off zone, a left-hand or landing zone and a neutral zone. At night the taking-off and landing zones are marked by white lights placed in the position of an "L," as shown in fig. 25.

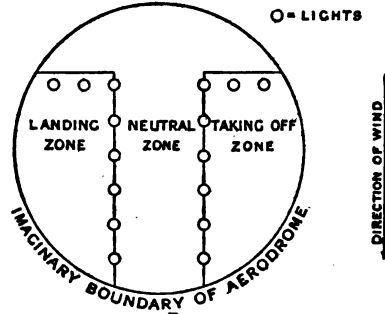

FIG. 25.

An aeroplane must land as near as possible to the neutral zone, but on the left of any aeroplanes which have already landed, and immediately taxi into the neutral zone. No aeroplane may commence to take off until the preceding aeroplane is clear of the aerodrome. A flag is hoisted in a prominent position to indicate whether an aircraft which finds it necessary to do so should make a left-handed (red flag) or right-handed (white flag) circuit. Aeroplanes must comply with this rule within 500-1,000 metres of the nearest point of the aerodrome unless flying at a height above 2,000 metres. The direction of the wind must be clearly indicated, and aeroplanes must take off or alight up-wind, those flying at a greater height being responsible for avoiding those at a lower. Aeroplanes in dis-

stress are given free way in attempting to land. At night suitable markings are required on all fixed obstacles dangerous to flying within a zone of 500 metres of an aerodrome.

The London terminal aerodrome at Croydon, Sur., may be taken as typical of a modern air-port for commercial traffic. It consists of a level grass field 900 yd. long by 800 yd. wide, and is equipped with a continental arrival and departure station, a customs office, repair shops and stores, aeroplane hangars and the private offices of companies engaged in air and road transport. An indicator, consisting of a conical linen bag, painted in conspicuous colours and attached to a mast, shows the direction of the wind by day; and the movements of machines are directed from a control tower. Along the south side of the aerodrome the name Croydon is let into the turf in chalk letters of 30 ft., legible from a height of 10,000 feet. For the assistance of night flying an aerial lighthouse shows the position of the aerodrome, while a searchlight distinguishes the aerodrome from its surroundings and illuminates the path of the machines. Electric lights are sunk into the ground to indicate the direction of the wind for landing. A wireless transmitting and receiving station is installed capable of telegraphic communication with ground stations within 400 miles and aircraft within 200 miles, and of telephonic communication within 200 and 100 miles respectively.

(b) *Coastal Stations.*—A sheltered stretch of water, usually an inland lake, was selected by the pioneers of hydro-aviation, a sloping beach, a rough shed and one or two small boats being the only other requirements. The equipment of the English station at Lake Windermere, the scene in 1911 of the first take-off and landing on water by a British aeroplane, was almost negligible, and it was not until 1913 that the first organized seaplane stations came into existence. The management of these stations is very similar to that of an aerodrome, with the exception of slipways up and down which aircraft are moved on leaving and entering the water, mechanical power for hauling heavy machines, and wheeled trucks to move them about on shore. At most of the early stations, however, man-power was sufficient to move machines, which were small and light, up and down the sloping beaches, while the pilot was carried to and from his seaplane while it was still afloat.

The first British flying-boat was produced in 1912, but it was not until 1913 that the larger boats were sufficiently developed to enable them to stay out on the water for days at a time. This development caused a corresponding expansion in the organization of seaplane bases. Launches and rowing-boats, used previously to assist machines in difficulties, became ferry-boats for taking fuel, stores, and personnel to and from the large flying-boats which were moored out to buoys in sheltered waters adjacent to the coastal stations. The organization and management of these depots, until the formation of the Royal Air Force in 1918, was modelled on that of H.M. ships.

Calshot, Hants., was in 1921 the most up-to-date coastal station in Great Britain; the sheltered area of Southampton Water provides ample sea room for craft getting off and alighting, while the narrow promontory on which Calshot Castle stands, almost surrounded by water, allows of numerous slipways for the handling of machines in and out of the sea at most states of the tide. Repair shops, sheds and living-quarters occupy a large area ashore; boat seaplanes, which are gradually replacing float seaplanes for all but special purposes, are moored out in a backwater; launches and rowing-boats are moored alongside a small pier, and trucks of special construction are held in readiness on the beach to move craft about on, when they have been hauled up the slipways by electric power capstans.

(c) *River Stations.*—The value of river stations lies in the fact that they can be located in the centre of many large cities, and passengers by air can thus save the time, now lost, in reaching aerodromes necessarily situated on the outskirts. River stations were still in 1921 in an experimental stage, but stations on the Thames, the Seine and the Spree will probably be developed to serve the three capitals—London, Paris and Berlin—which are already important airline termini.

(d) *Airship Harbours.*—In the early days of airships any convenient open space, such as a parade ground or moorland, was utilized, but as their size increased stations were selected so as to afford shelter from the wind, accessibility by air and

road, suitable accommodation for personnel, and privacy. In 1909 the Royal Aircraft Factory, then called the Ballouin Factory, Farnborough, was used for the first airship flights in England, and in 1912-3 it was provided with an elementary mooring mast. This station was abandoned in 1915. After the outbreak of the World War large airship harbours and construction stations were erected in many parts of the United Kingdom, thus following on the far greater development in Germany.

The first sheds for the housing of airships were comparatively small and constructed of various materials, such as canvas, wood or corrugated iron. As the development of the airship progressed these were superseded by sheds about 750 ft. long, built of corrugated iron on iron girders, and capable of accommodating two large rigid airships and several smaller non-rigid types. The annexes of the sheds contained all the requisite workshops for engineering, carpenter and fabric work as well as stores for general equipment and laboratories for research.

The development of the airship, however, was so rapid that it was not possible to keep pace with the construction of airship stations, which entailed considerable labour and expense. For this reason other schemes for housing had to be devised.

The first method for small airships was a reversion to the early one of "housing" them under natural shelter, but it had the disadvantage that the airship fabric rapidly deteriorated by constant exposure.

Owing, however, to the length of rigid airships it was impossible to dock them in this manner. Experiments were accordingly made for mooring them in the open by the three-wire system (see AIRSHIPS, Section 9). This was superseded by reversion to the mooring mast, which proved so successful that a large mast was erected at Pulham, where the first attempt was made in England to organize an airship harbour for commercial traffic, and the largest airships have been moored to it for long periods and in high winds. The adoption of the mooring mast has enabled the sheds to be mainly used for the housing of airships for the purpose of overhaul and repair, and has reduced the personnel required for handling airships on the ground from an average of about 200-350 to an average of eight men.

Airship harbours have facilities for gassing airships with hydrogen, either from steel bottles or by manufacture on the spot by the water-gas process.

(ii) *Signals.*—The methods for effecting communication with aircraft are ground signals, such as flags, pennants and ground strips; smoke signals, rockets, flares, flash lamps and searchlights; and wireless telegraphy (laterally also wireless telephony).

Visual signals for indicating wind direction and landing-grounds date from the birth of flying, while flash lamps, flares and rockets have long been used at night, or in fog. Ground strips of cloth or canvas, which are generally white on one side and black on the other so as to show up against dark and light backgrounds respectively, were placed in varying positions, according to a pre-arranged code. The flash lamp using Morse code was a little used prior to the World War, whilst the fier dropped written messages in a weighted bag attached to coloured streamers or a white parachute; early in the war the signalling-lamp (involving a knowledge of Morse by both operators) was employed.

Annex D of the International Convention prescribes that an aircraft in the air, or stationary upon land or water, but not anchored, shall carry forward and at the rear a white light, on the right side a green light, and on the left a red light. These lights, which are visible at varying dihedral angles and distances, are fixed so that only one can be seen at a time. On airships all lights are doubled. An aircraft when on the surface of the water, and not under control, displays two red lights visible all round the horizon. When moored, but not near the ground, the airship, the mooring-cable and the object to which it is moored are marked by lights or streamers.

An aircraft wishing to land at night on an aerodrome fires a green Very's light or flashes a green lamp, and makes by international Morse code the letter group forming its call sign, permission being given by the repetition of the same call sign from the ground followed by a green light. It is forbidden to land by the firing of a red light or the display of a red flare. If it is compelled to land, a red light is fired from the aircraft and a series of short flashes made by the navigation lights. When an aircraft is in distress it gives one or more of the following signals: the international SOS, the inter-

national code flag signal of distress, a square flag having either above it or below it a ball, a continuous sounding with any sound apparatus; or a succession of white Very's lights. The following signals are used to require an aircraft to land: by day, three discharges, at intervals of 10 seconds, of a projectile showing on bursting black or yellow smoke; by night, a similar projectile showing on bursting red stars or lights. In fog and bad visibility, sound signals may be used.

From the date of the formation of the British Royal Flying Corps in May 1912 the importance of wireless telegraphy in connexion with aircraft was fully recognized, both in the naval and military wings; and at a very early period of the World War its superiority over other methods of signalling from the air was clearly demonstrated. Standard patterns of instrument for naval and military work were gradually evolved; how reliable even these early types were may be seen from the fact that a few of them are actually still in use to-day in a practically identical form. The demand for the control of artillery fire by aircraft became steadily greater until, at the Armistice, on the British section of the western front alone there were over 600 aeroplanes and approximately 1,000 ground stations in use. All these machines were employing a spark system, and with the advent of the long-distance reconnaissance and bombing squadrons with their higher-powered sets the need became apparent for improvements allowing of less interference and, if possible, a larger number of machines working within the same limits of wave length.

The introduction in the early part of 1917 of the oscillation-valve continuous-wave transmitter—an extremely light and efficient instrument with a range of 100 m. from air to ground—overcame these difficulties and opened up a new vista with immense possibilities. Reception of ground-station signals by aircraft, although actually accomplished by the military wing at Farnborough as far back as 1913, became a reliably consistent proposition. Aircraft, whose duties carried them over considerable distances, were enabled to maintain a constant communication with their base, and, what was perhaps more important, the introduction of the continuous-wave set opened up the possibilities of the design of an efficient pattern of wireless telephone capable of withstanding the most rigorous usage.

Although hostilities terminated before the full benefits of these latter developments had become appreciable, the progress which has since resulted, both in service and civil aviation, is considerable. Airways have rapidly sprung into being, and the necessity for rapid signalling along the route, reporting arrivals, departures and delays of machines and of communicating with the aircraft themselves, has been responsible for the growth in England of the seven ground stations now existing, and, abroad, of the stations of the continental airports. The Air convention provides that every aircraft used in public transport and capable of carrying ten or more persons shall be equipped with sending and receiving wireless apparatus, and to-day most of the passenger-carrying aeroplanes of the London-Paris and other continental routes are equipped for the transmission and reception of wireless telephony, and are thus enabled to keep in touch with the ground throughout their flight. On several occasions during the year 1921 telephone conversation was carried out direct between a passenger flying between London and the Continent and a friend in his own home or office in London; the line telephone being used as far as the aerodrome station at Croydon, and thence being relayed by wireless telephone to the aircraft.

Another important war development, now becoming more and more extensively used, which was the outcome of the determination of the direction of passage of electro-magnetic waves, is the system of navigation by "direction finding," or "radiogoniometry." By this system two or more ground stations can detect the position of an aircraft using wireless telegraphy or telephony, and can pass that information direct to it within a few seconds.

The converse—an aircraft taking the bearing by W/T of two or more W/T stations on the ground can plot her own position, and thus enable the navigator to settle his position without asking for any information from the ground stations. This method is still in its infancy, but will undoubtedly prove of value to aerial navigation.

(iii) *Weather Information.*—The value of the collection and distribution of meteorological information for the assistance of aeronautics was early recognized, notably in Germany. In England in 1909 the Meteorological Office was represented on the Advisory Committee for Aeronautics; in 1910 a meteorological station was started at the Royal Aircraft Factory, and in 1912 at the Central Flying School at Upavon; both of these eventually prepared daily weather charts, and were the precursors of the present local distributive stations. During the war meteorological services developed under the War Office and the Admiralty, a portion of the service under the Admiralty being transferred in 1918 to the Air Ministry. In 1919-20 all branches of the Meteorological Service were co-ordinated and attached to the Air Ministry.

The information required for air traffic to-day consists of existing weather conditions on any route, or landing-ground forecasts and

warnings. General information as to weather conditions is provided by the Daily Weather Service of the Meteorological Office, which receives information by wireless telegraph or telephone four times daily from a network of observing-stations throughout the British Isles. The reports obtained from these are issued collectively in the form of synoptic messages four times daily, and are available to anyone within wireless range either in the British Isles or European countries; while the latter distribute their local information in a similar manner. According to the code drawn up by the International Commission for Weather Telegraphy the information transmitted to the Central Office in these reports consists of surface conditions, atmospheric pressure, wind, general state of the weather, temperature, visibility, humidity, cloud, rainfall, upper-air conditions, etc., the observations relating to each element being very detailed. In addition to the above, reports and forecasts usually covering a period of 24 hours are issued four times daily to each of four Aviation Weather Groups into which the British Isles are divided. Warnings are issued from the Central Office to all flying-centres where gales are threatened.

Local distributive centres are fully equipped meteorological stations established at certain important flying-centres, especially terminals, and will eventually number about twenty. Their duties include local observation and the issue of special information to the Aviation Services within their area. The establishment of a regular air service such as that between London and Paris entails a distributive station at each terminus, subsidiary observing-stations along the route, and the hourly distribution of information. While in the air the flier can obtain information as to the weather in front of him by wireless telephony or from ground signals. (V. B.-J.)

## VIII. SEAPLANES

*Early Attempts at Flying from the Water.*—Among the earliest aircraft designed to fly from, and alight on, the water were a French craft by M. Fabre (1910), the Parseval monoplane constructed in Germany in 1911, and the Grabardin monoplane tested at Monaco in 1911. Their difficulties were considerable and their successes slight, but by the end of 1911 floats were substituted for wheels on aeroplanes that were already proved to fly; thus in Oct. of that year Glenn Curtiss, in America, flew from the water on a craft adapted from the Curtiss aeroplane which won the Gordon Bennett Trophy at Reims two years before. Its performance as a hydro-aeroplane suffered from the extra weight and resistance of the floats. In England the first flight from the water was by Comm. Swann, R.N., and S. V. Sippe on an Avro biplane with 35-H.P. Green engine at Barrow-in-Nov. 1911.

Henri Fabre's "Canard," an original "pusher" monoplane with a 50-H.P. Gnome engine, made several straight flights at Monaco in April 1912, and Voisin, Caudron and R. E. Pellerie thereafter successfully equipped their standard aeroplanes with Fabre floats. This float was a fairshape, rectilinear in plan, and made of a wooden framework covered with proofed canvas. This type was displaced later by pontoon-shaped floats covered with 3-ply wood or mahogany planking.

In 1912 Colliex, on a Voisin "Canard" equipped as an "amphibian" with both wheels and floats, left the land at Issy-les-Moulineaux, and alighted on the Seine at Auteuil. Donnet and Levêque in France in 1912 built and flew the first boat seaplane, a two-seater pusher having a central hull with the engine above the boat, sufficiently high under the plane for the airscrew to clear the hull. The tips of the lower plane carried small floats to balance the craft on the water, and wheels were later fitted to the hull. The high centre of thrust relative to its centre of gravity, which signalized this craft, had been demonstrated in 1909 by Blériot on an aeroplane. The design of this boat generally made it the forerunner of the seaplane of 1920. In 1912 the Royal Aircraft Factory equipped an F.E. biplane pusher with floats, and later a tractor biplane was made there and flown from Frensham Lake to Southampton Water.

At the end of 1913, Short made a 100-H.P. Gnome tractor biplane waterborne on a single central float and small wing tip-floats. On the next seaplane, however, two floats were used in place of the central float. These craft and their successors proved fairly seaworthy, and were useful on naval manoeuvres. About this time the experience of the shocks met with, when flying from broken water, led to the use of rubber shock absorbers, between the floats and the supporting struts.

In America, following the lead of Glenn Curtiss, several aeroplanes were fitted with pontoons. Towards the end of 1912 Curtiss replaced the single central pontoon by a boat-shaped

hull, which carried the tail members. To protect the crew, a wood and canvas superstructure had been built on the fore-part of the original pontoon, making its appearance very similar to that of the later Curtiss flying-boats. With experience this pontoon was extended further aft to carry the tail members, and so this flying-boat appears to have been progressively evolved.

In April 1913 a prize of £10,000 was offered by the *Daily Mail* for crossing the Atlantic in 72 hours, and Rodman Wanamaker had a two-engined (2x90 H.P.) Curtiss flying-boat, called the "America," made for this. Loaded to the necessary 5,000 lb. gross, it could not leave the water. With a third engine it could do so, but the air endurance was thus reduced, and in July 1914 the flight was abandoned.

*War Period.*—Up to July 1914 seaplane design was thus very backward, and its war usefulness to a fleet was but little indicated. The non-existence of any particular line of advance that could be systematically developed had adversely influenced its evolution. In England in 1914 seaplanes were used in coast-defence work, and one seaplane carrier was in commission. By Aug. the carrying of aircraft on board ship had been facilitated by the introduction of folding wings, and their offensive value enhanced by the successful launching of a locomotive torpedo from the air. This led to the conversion of small passenger vessels into seaplane carriers, and soon the merits and limitations of the float type of seaplane were ascertained. As no launching- or landing-deck was available, the seaplane had to be operated from the sea, and this could be undertaken only in very favourable weather. An increase of air endurance and useful load was achieved, but at the expense of some of the seaworthy qualities. With a crew of two, wireless, and about 60 lb. of bombs, an endurance of two to three hours at 70 knots was possible.

By 1915 an improvement of the same type (known as the "Short 184"), which survived throughout the war, could carry a heavier load for about five hours. They were intended mainly for duties with carrying ships, originally proposed for service with the fleet, and with the light cruiser and destroyer squadrons. As, however, these "float seaplanes" lacked sea-going qualities, and their carrier ships were vulnerable, many of the operations intended for them were abandoned. They were utilized in the Gallipoli campaign.

Air-cooled rotary engines, used on the seaplanes of 1914 because they gave the lightest weight for power where weight was a cardinal consideration, soon proved unsuitable at sea, and were replaced by water-cooled engines. "Float seaplanes" were also employed with the Grand Fleet during the first two years of the war for observation with the fleet at sea, and patrol, but they were handicapped because their sea-going qualities were not adequate for the bad weather prevalent in the North Sea. At this time only one ship was provided with a fore-castle deck large enough to enable a seaplane to be launched therefrom on a light subsidiary carriage, thus avoiding the necessity for stopping the ship with the attendant risk from submarines, when getting a seaplane into the air.

In the absence of seaplanes with good sea-going qualities, ordinary aeroplanes were carried in fighting-ships with a launching-platform. Latterly carrier ships have been evolved with an alighting-deck as well. This led to the small seaplane not being pressed forward in the way the small aeroplane was by the stimulus of the war.

*The "Boat Seaplane."*—In 1914 there was in the British service a small Sopwith boat seaplane fitted with wheels (winner of the Mortimer Singer trophy), and also two small French and American machines. They could not carry any appreciable load nor could their wings be folded for operation from carrier ships; accordingly they were not then developed. In July 1914 Lieut. Porte, who was engaged upon the twin-engined boat seaplane, the "America," previously mentioned, was instrumental in developing the modern "boat seaplane." In 1915 several "Americas" with their two 90-H.P. engines were delivered at Felixstowe. Their performance was poor on account of their lack of horse-power for their weight, and they were too small—36 ft. hull—to give good sea-going qualities.

The much larger "Porte" boats with their three engines of 275 H.P. and air endurance of 8 hours, a total weight of about 8 tons, and a hull 60 ft. long, were laid down. The increase of dimensions carried with it a great improvement in sea-going qualities, but the air performance was but little better, and the type was not further developed. One H.P. for 20 lb. was insufficient power, and bigger engines for the weight had to be used.

The Curtiss "H8," built in America, was better in this respect. Only one of these was made, but knowledge obtained in England during its construction was embodied in its successor, the "H12." Many H12's, with 340-H.P. Rolls-Royce engines, were used with success against submarines. The H12's weighed 5 tons, carried 5 persons and 500 lb. of bombs at 80 knots for 6 hours, and were armed with three or four machine-guns. They had 1 H.P. for every 16 lb. and when first used had a higher performance than any other sea-going aircraft over the North Sea. They showed that hydroplaning efficiency, previously regarded as cardinal, could be sacrificed for sea-worthiness, provided sufficient engine-power were available.

All the earlier types, including the H8 and the H12's, were practically flat-bottomed, and pounded heavily in disturbed water; the higher power available in the latter type enabled these seaplanes to take off rapidly and the improvement of providing them with a pronounced V-section bottom was adopted first on a small "America," and then on the H8 with the two Eagle engines.

This combination of Felixstowe hull, H8 wings with Rolls-Royce engines known as the F2 was the forerunner of all the many boat seaplanes of the latter part of the war. These craft, one of which is illustrated (see Plate II.), corresponded in size, weight and power to the H12 type, but on account of their V-section hulls, were capable of alighting in, and taking off from, disturbed water with less risk of damage to the hulls. Their effectiveness against submarines led the Germans to evolve high-performance two-seater fighter seaplanes of the float type. Among the most effective of these were the Brandenburg monoplane seaplanes. These remarkable craft became useful as a menace to the heavier "boat seaplanes," and as they were carrying only a light machine-gun load and comparatively little fuel they out-maneuvred them.

It has been seen that the small seaplane that might have countered these was undeveloped in England. The defensive armament of the large seaplanes was increased, though such additional load adversely affected their performance and sea-going qualities. Small two-seater seaplanes to escort the larger ones were constructed, but as these were not delivered until after the cessation of hostilities, the technical advantages to be derived from this new field of study were only partly reaped. Summarizing the above we see that the smaller boat seaplane originated in France, the large one in the United States of America, the very large one in England. Many seaplanes were brought to England from America were improved by experience obtained in Britain, and subsequently the types designed at Felixstowe and built in England were reproduced in America in quantities.

The construction of the American "NC" type, and its crossing of the Atlantic, was a wonderful achievement. The fact that from lack of fuel "NC3" alighted in mid-Atlantic, and arrived at Ponta Delgada after travelling 180 sea miles on the water in 54 hours with bad weather, pays a high tribute to the design and is a sign of the future value of the seaplane in commercial transport.

In France the war incentive to seaplane progress was lacking. France has mainly used the small boat seaplane for coast defence, and patrol for submarines. Up to the end of 1918 sufficiently high-powered engines were lacking for sea-going craft; the Hispano-Suiza 200-H.P. being in most general use.

In July 1914 the Germans had few seaplanes in service, and of these one had been imported from England. They were nearly all of the two-float type, and suffered from the defects of that type previously mentioned. Their activities were mainly defensive, and did not require either long endurance or good seaworthiness. Torpedo-carrying seaplanes were made use of in

1916 from the Belgian coast in attacks on merchant shipping, but these were not required to cover great distances, and were not remarkable. Isolated small boat seaplanes have been constructed in Germany, but not in quantity.

The Germans (no doubt in consequence of their greater study of airships) continuously kept a heavier, and more reliable, engine than the Allies, but by 1917 the Allies had produced higher-powered units, and it is probable that these two facts are mainly responsible for the German retention of the smaller "float seaplane." Moreover, their engine failures at sea were few, and there was not, therefore, so much pressure for their seaplanes to withstand open sea conditions.

The Brandenburg seaplanes of 1917-8 had rather heavy engines of 180 to 200 H.P., yet they had very high performance. Their success in fighting was due to the unusual monoplane wing arrangement which gave a clear field of fire in all directions above the horizontal plane, and to their clean general design without any external wire bracing. They employed the more recent type of twin floats.

Before the period of limitation of aircraft construction set by the Allied Commission of Aeronautical Control, the Germans had been developing the giant aeroplane in several experimental forms, differing mainly in the arrangement of multiple-engine units. These ranged in total weight roughly from 9 to 12 tons, and in the case of the larger types difficulty was experienced in providing sufficient area of contact between the wheels and ground. This difficulty did not exist in the giant seaplanes, a few examples of which had been built by the Zeppelin works on Lake Constance. Their aerodynamic design was not good, and the type was not perpetuated in its original great size on account, probably, of difficulties of control. The Staakener Giant was another example; this had two long floats made entirely of duralumin. These giant seaplanes would no doubt have developed but for the prohibition, and an interesting comparison of advantages would have been obtainable between the giant seaplane, and the giant aeroplane.

**Characteristics of Seaplanes.**—The boat seaplane, a craft suitable for less-sheltered waters than the early float-equipped aeroplane, or hydro-aeroplane as it was called, must, to be of real value in naval operations, be fully sea-worthy, and such progress as had been made had not yet proved by 1921 whether this was completely obtainable. But there were then—(1) the smaller craft to operate from sheltered waters, rivers and lakes, and (2) the boat seaplane to operate overseas. The first includes all types of small dimensions of less than, say, 4 tons, and all existing "float" types in 1921 fell into this category.

To the considerations of design, stability and control applying to aeroplanes must be added the design and distribution of the float system, so that the forces due to water shall not affect adversely the stability and control. These water forces are controlled by means of the aerodynamic elements, which are ineffective except at the higher hydroplaning speeds. Hence the float system must be such that any instability that occurs between the air-borne and water-borne conditions shall take place at speeds high enough for the air controls to be dominant.

Wheeled seaplanes, for land and sea alighting, had been built by 1921 as experiments, but their development had only just begun. Their wheel system springing, ground clearance and like factors are those of the aeroplane. These amphibians are handicapped by the weight of the float system, but show promise of very useful speed and climb.

Most large centres of population possess areas of smooth water, rivers, lakes or harbour, affording an alighting area comparable with the average aerodrome, and if the proposed route provides large water areas for any forced alighting, this fact can be taken advantage of by carrying a heavier load per sq. ft. of wing area with a corresponding gain of speed, reduction of structure-weight and increase of efficiency.

The desiderata for seaplanes for the open sea are less well known, and more difficult of attainment. They must for sea-worthiness be large. They had reached 15 tons by 1921 and were still far below the dimensions of the small coasting vessel; with the existing constructional materials science places a very early and definite limit to the increase of size possible. In order to enable even a 15-ton seaplane to carry a reasonable weight of fuel, crew and equipment, the load factor is in some cases reduced to three and a half. The increase of wing-loading, though it entails a higher stalling speed, and the adoption of a wing-section of high lift, may yet improve matters.

For commercial purposes, a high top speed is not so essential as for war, and model tests indicated in 1921 that the overall efficiency of a seaplane with high-lift wings may compare with craft with the usual faster wing. The reduced area of wings so obtained has kept

down the structure weight. For war the wing whose camber is variable to give high speed with good lift at low speed may be perfected.

Three arrangements of "float seaplanes" are possible; in all, the engine, crew and loads are carried in one or more fuselages well above the floats in such a way as to bring the centre of gravity and thrust axis into approximate alignment:—

(a) Two main floats which together support the whole weight and provide lateral and longitudinal support.

(b) Two main floats together with one or more tail floats, the former supporting nearly the whole weight, but being dependent on the latter for longitudinal support.

(c) One central main float supporting the whole weight and providing longitudinal support, two comparatively small wing floats providing lateral support.

Systems (a) and (b) provide positive metacentric height both longitudinal and transverse, while system (c) is always dependent on the wing floats for lateral support; for small angles of roll this is lacking, as it is necessary to carry the wing floats clear of the water when the seaplane is on an even keel.

Systems (a) and (b) are most usually employed because they avoid this defect. A main advantage of the system (c) is that the float impedes the view much less.

Arrangement (a) is better than (b), as the tail float of (c) is easily damaged, and thereupon longitudinal support being lost, the seaplane turns over on its back.

Float seaplanes have the following merits over the boat type:—

(1) They can be handled on slipways with the most primitive arrangements, and can be beached safely on any smooth foreshore.

(2) The aerodynamic elements give the normal balance, stability and control.

(3) They may be convertible into aeroplanes, or vice versa.

(4) The floats are simple in design, and can be subdivided into watertight compartments.

(5) The static transverse stability of systems (a) and (b) enable the wings to be folded afloat, for hoisting the craft from the water to a ship or a quay.

(6) For war, good arcs of fire are obtainable over the rear hemisphere.

The following are the disadvantages:—

(1) The floats are uneconomical of structure-weight.

(2) The aerodynamic drag is comparatively high.

(3) Arrangements (a) and (b) cannot be used for larger craft than 3 tons as heavy racking stresses are set up in the structure connecting the two floats when on disturbed water.

In the "boat seaplane" the displacement of the craft is borne by the central hull. Longitudinal stability on the water, both static and dynamic, is supplied by the length of the hull, and the distribution of its planing surfaces. Wing-tip floats are necessary for lateral support.

The advantages of the type are as follows:—

(1) An excellent crew position for flying and observation, e.g. in anti-submarine operations.

(2) Comfort: the crew can move about, the pilot be relieved, etc.

(3) Economy of structure-weight.

(4) Compact design—low air drag.

(5) Absence of racking forces, and large size possible. This last advantage is the most important, and the limit of size of aircraft, as already discussed in the section on "aeroplane design," applies here save as regards the hull. Experience shows that the hull weights do not increase even in the same proportion as the total displacement, a slight reduction in the ratio of the hull weight to total weight having been obtained, and if this continues further, it is clear that a reduction in hull weight can be set off against an increase in wing weight, resulting possibly in the most economical scale being greater than anything yet constructed.

The disadvantages are:—

(1) The wings cannot be folded afloat.

(2) Cannot be beached except in very soft mud, and requires elaborate apparatus to move it to a shed on shore.

(3) In war it is difficult to defend from attack astern.

(4) The large distance between the centre of gravity and the thrust axis, and the low position of the centre of gravity in relation to the centre of lift. The former produces a variable pitching moment, the latter influences adversely the lateral control.

**Elements of Design Peculiar to Seaplanes.**—Many of the desiderata in a seaplane design are antagonistic to each other.

Flight can be achieved with 1 H.P. for each 25 lb. to be flown, but good speeds and climbing need 1 H.P. for each 8 or 10 lb.; therefore, structure-weight must be economized.

No wings can stand a blow from any large volume of water. The wings must clear the waves and any but light spray. Regarded as an aircraft the centre of gravity of the whole and the centre of pressure of the wings should be nearly coincident, and for this the centre of gravity should be high above the water. As a watercraft, however, a relatively low position of the centre of gravity is needed in relation to the waterplane. The compromise necessary puts the centre of gravity so that the metacentric height (apart from the wing-tip floats) is negative.

The position of the airscrew dominates the design. Air inflow near the blade-tips sucks spray off the sea, and picks up spray thrown by the hull, with damage to the blades. This is prevented either by putting it high up or over some part of the seaplane, e.g. the lower wing or hull. This places the thrust axis well above the centre of gravity, and the smaller the seaplane, the more this effect is notable. The high thrust axis produces a downward pitch varying from zero in gliding flight to a maximum at full power. In the earlier boat seaplane this was uncorrected, and, in order to get balance in normal flight, the craft was very "tail heavy" when gliding.

This effect has been diminished by placing the tail plane in the slipstream, by setting it at a negative angle to the chord of the main planes, and by distributing the weights so as to bring the centre of gravity particularly far forward. The thrust-couple thus opposed by the tail-couple can be nearly balanced out. As the main reactions on the tail are downwards, the tail plane is sometimes set with the camber downwards.

Unusually large airscrews and geared-down engines are used for efficiency at low speeds, i.e. at about  $\frac{1}{10}$  of the stalling speed, because the water resistances are greatest at this speed.

The hull must provide longitudinal stability, both at rest and in motion on the water. To ride in a seaway and not bury its nose when accelerating, a long forebody is used. The section of this part should be veed at the keel, and well flared at the chines; respectively to reduce shocks from on-coming waves, and to keep the divergent wave formation low and clear of the wings and airscrews. For the same reasons the keel and chine lines have a gradual rise forward with overhang forward of the fore-end of the water-line.

At least a 300% reserve of buoyancy is given to boat seaplanes to provide adequate freeboard at sea. With watertight floats 120% reserve is adequate.

Above  $\frac{1}{10}$  of the minimum flying speed, called the "hump" speed, the water resistance due to wave-making begins to fall. Above the hump speed the water resistances are probably due as much to skin friction of the planing surfaces as to wave or eddy making, and by disposing steps in the planing bottom, the wetted surface, and consequently the resistance is reduced. From the hump speed onwards these hydroplane resistances decrease, the weight is transferred more and more to the wings until the seaplane leaves the water.

The larger the planing surface (i.e. the wider the beam) the sooner the hull rises, and the earlier the hump occurs, but this increases the resistance at lower speeds, and makes the hull heavy for its strength.

Models tried in the Froude National Tank at Teddington (England) show that but a slight reduction of max. E.H.P. at or about the hump speed is obtained when the beam exceeds about  $\frac{1}{2}$  the length of forebody. Where a higher power is available on other accounts, the beam may be still further reduced. A narrow hull with spray-deflecting sections, and without flat surfaces, or main "step," though desirable, was found not to give the necessary lowering of resistance beyond the hump speed. The resistance increased as the displacement diminished with speed.

The main "step" under the centre of gravity was proved necessary, but the area of the planing surface forward of less importance. The boundaries of the planing surfaces must have sharp edges to make the water break clear away from them; water clings to rounded surfaces even of small radius, and these would cause unnecessary resistance. The angle between the hull surface at the chines and steps should not exceed  $90^\circ$  for the same reason.

In a seaplane hull we require static stability at rest on the water, and dynamic stability in motion at the higher speeds. Longitudinal stability of the whole at rest is obtained by the length of the water-plane area and presents no difficulties.

The tendency of all craft to trim by the bow at low speeds is aggravated in the seaplane by the high thrust axis. The heaviest waves are formed while this tendency to dive is still present, and it is at these speeds (in the region of  $\frac{1}{2}$  to  $\frac{1}{4}$  of the minimum flying speed) that clean running in disturbed water is most difficult to attain.

The modern hull possesses large restoring moments at small negative angles of trim, but if the forward trim exceeds about  $3^\circ$ , the moments will have become negative, and an attempt to alight at such an angle will break up the hull.

Lateral stability at rest (though sought in early boat seaplanes by providing sufficient beam to give a small positive metacentric height) is destroyed by the lightest side wind, and therefore wing-tip floats are a necessity. The transverse metacentric height is always negative to-day, and wing-tip floats are relied on.

Stability in the hydroplaning condition becomes increasingly important with size. Beyond the hump speed the hydrodynamic reactions, the air reactions and, to a diminishing extent, the buoyancy combine to support the hull, and to determine the stability of the whole. Just above the hump speed hydroplaning reactions are great, while the air-forces are small; so are the moments due to the air-controls. Here the planing surfaces and steps must afford stability. When the speed increases the water-forces become less, and the air-forces greater, till, on approaching the minimum flying speed, any instability that may occur can be counterbalanced by the air-controls. In the latter seaplanes, however, the water moments may be large even at high speeds, and their hulls must, therefore, be stable over the whole range of water speeds.

The stability depends on the relative size and positions of the steps and planing surfaces, on the angles of the planing surfaces to the mean water-line to each other, and to the chords of the aerofoil surfaces; and on the position of the centre of gravity in relation to these and to the height of the thrust axis.

The problem is one of great complexity, and partly on account of its recent origin is as yet unworked.

During the war, model work was called for on individual designs and delayed the general investigation, but clues have been found. Usually the smaller hulls are proved more apt to develop instability both in the tank tests and on the full scale. The minimum flying speed being much the same on large and small seaplanes, the wave lengths at any given speed are much the same. A hull of 45 ft. gave best results with the main step slightly forward of the C.G. and the rear step, very small relatively, 18 ft. aft of it. Here instability was delayed until the air-controls were effective, and when tried in the full scale, no instability was apparent, probably on account of the damping action of the air-surfaces, since the seaplane took the air without operation of the controls by the fier.

A somewhat similar model of a much larger seaplane with steps 32 ft. apart was stable throughout the speed range.

In the small types the hull length restricts the distance apart of the steps. The two steps may be compared to the wings and tail surfaces of an aeroplane; the main step nearly under the C.G. does the lifting of the boat on to the surface, while the rear step provides the pitching moments for equilibrium, and is most effective for this purpose when far aft and of small dimensions. Tank experiments on models show that not more than about  $\frac{1}{10}$  of the total resistance is due to the rear step and after body. The two steps must also be arranged in such a way that the intermediate hull-sections and that part of the hull carrying the tail surfaces, aft of the rear step, are clear of the two depressions formed in the water by the passage of the steps. The object is to reduce the wetted surface, aft of the main step, to the minimum necessary (at the rear step itself) to give stable conditions. This best arrangement can only be obtained, at present, by individual model experiments. The full scale has corroborated the results, and accordingly the resistance, running angles, pitching moments required for equilibrium and general characteristics of running can be obtained in the Froude tank, where waves can also be reproduced artificially. Tests show that complete stability on the model is obtained under more difficult conditions than in the full scale, hence the seaplane corresponding to a stable model may be fully relied upon.

*Between Air and Water.*—The water reactions on a badly designed hull may continue to be considerable up to the moment of quitting the water; then, their sudden disappearance may produce moments dangerous at a time when their correction by air-controls requires big movements. Such a seaplane at a high speed on water, and kept at the angle for maximum lift of the wings by means of the air-controls, is subject to a moment in pitch due to the water reaction on the steps. This is balanced by a moment due to the elevator until it leaves the water, when all the water forces are lost. If the elevator moment, which had been applied by the fier were positive (i.e. increasing the angle of attack), the seaplane would stall. These moments should either not exist or be negligible. If they do exist they are less dangerous if operative in the inverse sense to those in the example. Their existence can only be ascertained, and as a rule eventually eliminated, by experiment. From such experiments a canon for design will be evolved.

To keep hull weight low there are special methods of construction. The timbers used in boat-building practice have so far been found best. In the present sizes steel is out of the question. Aluminium alloys have been used in Germany with success for float construction, but it is doubtful whether duralumin or any other aluminium alloy is superior to mahogany for the hull skin as regards strength, hysteresis or durability. In any case of timbers, mahogany is the best for this purpose.

Unsuccessful attempts have been made to depart from the timber principles and practice of light boat building. A planked skin through-fastened on to timbers and stringers in the usual manner is essential for watertightness and durability.

Design is addressed to keeping down the weight of the skin, and its supporting structure. Seaplane hulls have been built having a bare weight from 20% to 91% of the total weight. The latter figure was got on a boat displacing about 15 tons.

The two principal methods of construction are: the rigid and the flexible. For most hulls the skin is supported by a rigid structure which permits of easy subdivision by transverse bulkheads like the ordinary steel steamship except that timber is employed. The main objection to this method is its low specific strength. The rigid structure produces strong local points in the skin with intermediate areas poorly supported, resulting in sudden changes of cross section and localized deflections under load. Such a hull to have sufficient strength for taking off in disturbed water weighs 15% of its displacement at least.

The flexible method as developed by Linton Hope has its transverse sections approximately circular throughout the whole length, while the planing surfaces are built on outside the main hull, producing what is virtually double bottom. The structure is tubular, its whole strength being concentrated in the skin and its local support-



ing members. Two or more thicknesses of mahogany-planking are through-fastened to transverse timbers of small section closely spaced; these are connected longitudinally by a large number of stringers of rectangular section lying in a radial plane, edge on to the timbers; the stringers are in turn supported on their inner edges by *clm* hoops of comparatively heavy section widely spaced. The small section timbers are placed so closely that no fastenings need be passed through the skin anywhere between timbers. This type is water-tight, durable and light. The average hull weighs not more than 11% to 12% of its displacement.

The flexibility absorbs the shocks of alighting and taking off, and precludes heavy local pressures. Care is taken to distribute the air loads, which are generally concentrated along two lines transversely to the axis of the hull, over a sufficient area of the skin, and all internal installation is arranged to allow for comparatively large relative movements of components. Transverse subdivision is practically impossible, but the provision of a subdivided double bottom is easy and effective.

*Seaplane in Operation.*—The preparations made for housing and upkeep of seaplanes were unfortunately dominated by the requirements of the early types. The seaplane station was modelled on aerodrome lines, with the addition of a slipway to the water. The flat floats of the float seaplanes were placed on trolleys, and thence by slipways to the water. The delicate V-section hull of the heavy boat seaplane is ill-suited for such handling. The draught of the modern boat (with a trolley under it) exceeds what can be negotiated by men in waters. If such boats are to be brought ashore at all new devices are required for doing so. Experience shows that boats of only 5 or 6 tons are damaged in such handling, though they draw little more than 2 ft. of water. To limit the bringing ashore to slack water periods in good weather, would be intolerable for commercial work. Better water-side facilities, such as covered sheds with direct access to the water for the construction, erection and repair of modern seaplanes are needed. These should allow of admitting water to part of the shed to reduce the out-of-water handling to a minimum. As a large expanse of sheltered water is necessary, and the rise and fall of the tide is important, floating sheds may be needed.

Closed sheds are not essential for operating seaplanes. The larger the seaplane the more can it resist exposure for long periods, and the practice of mooring out will become an economical necessity, but the seaplane must be designed with this in view, and proper auxiliary services for heating, fuelling and repairs provided. In high winds seaplanes moored out have risen off the water at their moorings and destroyed themselves, but this is avoidable by destroying the air-flow over the lower planes by attaching light boarding along the leading edges at a large negative angle to the chord. As the seaplane for commerce has been but little studied, marked developments may be expected in this direction; sea-worthiness is still the main problem for warcraft and increase of size the most direct solution.

In transport work, sea-worthiness is an insurance against engine failure; remove this risk and operation would take place from sheltered water only, design would be freer, size would be dictated by load, capacity and economy. The need to counter the winds rather than competition against the slow surface ship would dictate the air speed of such craft.

For operation from smooth waters structure-weight and hull weight can be reduced and wing load increased, while high-lift wing sections also offer much promise.

It is remarkable that though the viewpoint for seaplanes is so different from that for aeroplanes, the reliable engine unit is equally found to be the prime desideratum for present progress. (A. J. M.)

IX. AIRSHIPS

Airships are divided into three main types:—(1) The rigid, which has a hull structure of rigid members covered by an outer fabric fairing, and containing a number of separate gas cells. (2) The semi-rigid, in which the whole or part of the bending and longitudinal compression induced in the ship by the rigging wires is taken by a rigid keel: The envelope from which this keel is carried is kept distended by the pressure of the gas, but is mainly subject to vertical loads. (3) The non-rigid, in which the envelope maintains its shape solely on account of an internal pressure which must exceed the outside pressure.

Small airships up to, say, 300 ft. long are necessarily non-rigid, as there is not sufficient lift to justify a rigid framework. The largest airships have a rigid hull structure because the pressures involved in an envelope of large diameter necessitate very heavy fabric and make a system of compartments essential. Between the two, the semi-rigid seeks to reduce the fabric tensions by the use of a rigid keel girder, but it is doubtful whether this justifies the keel, except as a convenient means of carrying the loads from the envelope.

A rigid airship has a hull structure of light aluminium girders, arranged with some 25 longitudinals connecting some 17 main transverse polygonal rings. At each main ring a bulkhead is formed of the load wires which suspend the weight of the keel from the upper part of the framework and the radial and chord wires which retain the shape of cross section of the ship. A specially strong keel of triangular section and some 8 ft. high runs nearly the whole length of the ship and carries the petrol tanks, water-ballast bags and other weights, being itself supported at the main transverse rings. The 30-metre spaces between the bulkheads are each fitted with a single gasbag of gas-tight fabric. The degree of fullness of these bags varies from the maximum to sometimes less than 50% full, when the upper parts of the space alone will be occupied by the bag, whose lower part is collapsed and empty. A cover of fabric is stretched over the outside of the whole frame, so as to present a smooth surface and protect the gasbags from weather and light. Separate engine cars are attached below the hull at points along its length.

Performance Table of Seaplanes, 1914-20.  
Flood Seaplanes.  
1914.

Type	H.P.	Useful Load Including Crew (lb.)	Endurance Hrs.	Maximum Speed in m.p.h. at Sea Level	Span	Total Weight*	Maximum Total Weight	Effective Ceiling
M. Farman	100	880	3	62	63	2,130	2,130	..
Short	160	850	4	74	56	3,000	3,000	..
Sopwith-Schneider	100	340	2	90	26	1,500	1,600	..
1915.								
Short 184	225	1,300	5	68	63	4,700	5,000	..
1916.								
Sopwith-Schneider	130	515	2	100	26	1,790	1,790	..
1917.								
Fairey Type III.	260	1,190	4	90	46	4,159	4,300	14,000
Short 184, Improved	260	1,748	5	29	63	5,250	5,250	5,500
Short 320	320	2,140	3	73	74	7,000	7,000	3,500
1918.								
Fairey Type III. c.	360	2,408	5	108	46	4,800	5,000	15,000
Westland Single-Seater	150	474	2	103	31	1,987	2,000	10,400
Hanriot Single-Seater	130	585	3	117	28	1,825		
1919.								
S.V.A.	200	495	3	124	30	2,195		
1920.								
Fairey Type III.	480	3,479	4	118	46	5,250	5,250	

\*Total weight carried (for performance shown).



Performance Table of Seaplanes, 1914-20.  
Boat Seaplanes.  
1914.

Type	H.P.	Useful Load Including Crew (lb.)	Endurance Hra.	Maximum Speed in m.p.h. at Sea Level	Span	Total Weight*	Maximum Total Weight	Effective Ceiling
Curtiss America	180	650	3	65	76	4,000	4,500	..
F.B.A.	100	630	3	68	40	1,825	2,000	..
1915.								
Norman Thompson	120	835	4½	78	48	2,600	2,600	..
1916.								
Large America. Hra	690	1,357	6	97	95	10,650	11,000	10,800
Porte Boat	1,080	3,900	7	88	124	18,600	18,600	8,000
1917.								
A.D. Boat	200	1,066	4½	93	50	3,560	3,600	11,900
1918.								
F5 (Light Load)	720	1,607	8	101	104	9,630	13,300	17,400
Phoenix P5 (Light Load)	720	1,773	7½	105	87	9,210	13,300	15,100
Tellier	350	2,640	6	90	76	7,160	7,160	..
1919.								
Felixstowe Fury	1,800	6,690	10	95	123	25,250	28,000	12,000
F.B.A.	200	1,320	4	87	51	3,520	4,000	..
Nieuport Macchi	260	595	3	127	40	2,245	2,245	..
N.C.	1,600	12,000	14	85	126	28,000	28,000	..
Dornier G.S.I. (Zeppelin)	520	2,800	3½	112	65	9,500	..	..
1920.								
Vickers Viking Mk. III.	450	1,278	4½	121	46	4,900	5,100	..

\* Total weight carried for performance shown.

The early development of rigid airships was carried out by Count Zeppelin in Germany, and represents an extraordinary record of perseverance. This development was only rendered possible by political influence and by the repeated financial assistance available. The Schütte-Lanz airships were of wooden construction and developed more slowly. They appear, however, to have embodied considerably more original and perhaps courageous developments than did the Zeppelins, which were developed more as gradual minor improvements on the original design.

British Rigid Airship No. 1 was started in 1909. During the construction great consideration was given to the various auxiliary gear required by the ship and to the problems included in the handling and mooring as well as the actual flying of the ship. The thoroughness and accuracy with which this auxiliary work was developed is most remarkable in the light of later experience. Before the first flight was made the ship was moored by the bow to a mast with her cars resting on the water. The ship was broken amidships in Sept. 1911 as the result of a mistake in handling while she was being returned to her shed after one of the trials of handling before flight. Comparison of the details and estimated performance of this ship with the contemporary Zeppelins shows that she was a remarkably good first design and that had it not been decided to abandon rigid-airship construction the British development of these ships would almost certainly have become at least equal to that of Germany.

British Rigid Airship R0, by Vickers, stopped at the beginning of the World War, was restarted in July 1915 and made her first flight in Nov. 1916. She made a rather remarkable passage to Howden through a snowstorm over the Pennine range. Being somewhat inadequate in buoyancy, she was used for instruction and ultimately for mooring experiments.

She was followed by four ships of R23 class, built by Vickers, Beardmore and Armstrong, and again by R27 and R29, which were remarkable for the absence of the keel which had existed in all previous rigid airships and had been looked upon as constituting the real strength of the ship to resist bending and shearing forces. This keel subsequently reappeared in German Zeppelins and in the ships built in England, but then merely as a means of distributing to the main frames the weights of petrol tanks, etc., arranged along it.

Two woodenships, R31 and R32, were built by Short to a design closely similar to that of the Schütte-Lanz type. They were considerably faster than contemporary ships.

Rigid-airship construction in Germany had advanced continuously and was, therefore, greatly ahead of French and British. A combination of the talent and experience of the Zeppelin and Schütte-Lanz firms early in 1916 resulted in the design of L30, giving a speed and performance far ahead of any earlier ships. L33 of this class was brought down in Sept. 1916 in such a comparatively undamaged condition that it was possible from her to prepare a design in England to which R33 and R34 were built. These ships were not, however, completed till late in 1918.

The German L65 class marked a further advance in speed and performance, while the L70 class, of which the first ship, L70, was destroyed on the first flight to England with some of the chief constructional experts on board, marked still further progress in performance and in the simplification of the machinery installation, in the adoption of fins of triangular cross section. L74, which was not actually completed until after the Armistice, had again a slightly higher performance.

After the Armistice Germany built a much smaller airship, the "Bodensee," for commercial purposes, and with her carried out a remarkable series of passenger flights. The ship was then enlarged and a sister ship, "Nordstern," also constructed.

Subsequent to the R33 class the British R36 and R37 were constructed to a generally similar design, of somewhat greater capacity and much improved detail. R20, designed and constructed by Vickers, embodied several entirely new features, but her size was so restricted by the dimensions of the construction shed that her performance was seriously handicapped. R38 made radical changes in features of design, and a clear and definite departure from German methods. The United States had contracted for its purchase. It was to be used, as it was generally understood, for an experimental service from New York to San Francisco and for that purpose masts and intermediate stations were being prepared. R38, while on the final test flight before delivery on August 24 1921, caught fire and fell owing to structural weakness, and many lives were lost.

*Non-Rigid Airships.*—In 1913 the chief general classes of non-rigid airships were:—(1) Those with a plain circular envelope from which the car, etc., was suspended from special fittings on

the envelope, and of which the British military airships are typical. (a) The Parseval type, in which the circular envelope is reinforced against bending under the rigging tension by Parseval trajectory bands passing over the envelope and secured to a girde to which the car is rigged. (3) The Torres type, made by the Astra firm of Paris, trilobe in section, with riggings led inside the envelope and divided into fans secured to points along the two top ridges.

The two latter systems are intended to decrease the distance between the envelope and the car without producing excessive tendency to bend in a large ship.

At the beginning of the war the French had several non-rigid ships of various types which carried out bombing operations, but no important new ships were built. Germany had a few Parseval airships, which did a little work on the Russian front, but there was no important development of small ships. England had three small non-rigids, also one Parseval and one Astra. It became necessary, however, at the beginning of 1915 to develop the very small non-rigid airship as rapidly as possible as an anti-submarine protection. Extreme simplicity was essential in order to allow of rapid production by firms having no previous experience. For the first 30 ships aeroplane bodies were used as cars, but later special cars far more suitable for patrol work were adopted. Engines of about 90 H.P. were used and a crew of three carried. Some 150 ships of the S.S. classes were built, but at the end of the war it had been decided to adopt a slightly larger ship with twin engines and a crew of five as being more suitable for the longer patrols which became necessary. Later in 1915 a larger type—the Coastal class—having greater speed and taking a crew of five, was built. For these the Astra system of rigging was adopted in order to reduce to a minimum the necessary height of the sheds. Thirty-five of these ships and ten of an improved (C<sup>o</sup>) class were built during the war. These ships later carried a crew of five and had an endurance of 12 hours at a full speed of 51 knots. In 1916 the first ship of the North Sea type was flown. This class was intended to work with the fleet and had an endurance of some 24 hours at 50 knots. Sixteen of these ships were built.

The characteristic of these ships, more particularly the N.S. class, was that the petrol tanks and all other weights possible were carried direct on the envelope. In the N.S. class the car was separate from the power unit and the weight distributed over the length of the ship. This gave important advantages over all earlier non-rigids where the loads had been concentrated in the car. The S.S., Coastal and N.S. classes were all designed and built at the R.N. Airship Station, Kingsnorth. They constitute a very interesting development from the small supply of ships and experience available at the beginning of the war.

A considerable number of British non-rigid airships were built and supplied to the French, Italian, Russian and American services, and one Italian semi-rigid was supplied to England for experiment. A large Astra ship of some 800,000 cub. ft. capacity was built in France with two large cars. It is understood that lack of longitudinal rigidity of the envelope gave trouble.

The Italian airship design has favoured the semi-rigid type of construction, their most successful type being one in which the keel girder was not in itself rigid but "vertebrate," consisting of a number of pin-jointed frames capable of taking the longitudinal thrust induced by the car riggings, so long as the envelope held the keel in line. This system did not greatly reduce the height of the ship, as the points of attachment of the riggings were necessarily at the bottom of the envelope instead of near the level of its centre line. It did, however, enable a much lower envelope pressure to be used than in the non-rigids of the same size. This enabled a very light envelope fabric to be used and also a system of automatic pressure regulation by air taken at the nose of the airship. These ships were designed for bombing raids at great heights across the Adriatic Sea. The excellent weather conditions rendered their comparatively slow speed quite satisfactory.

Germany built a few large semi-rigids of the M type and the Parseval type. The two largest, PL26 and 27, were of some

1,120,000 cub. ft. capacity. They embodied many interesting features, including spherical partitions which divided the envelope into sections so that the accumulation of pressure at the upper end of the ship when pitched was avoided. As far as is known, no very thorough trial of these ships was made, but as far as the experiment was carried it appears to have been satisfactory. The type was not, however, proceeded with on account of the decision to concentrate on the rigid type.

Italy, after the Armistice, built a large semi-rigid "Roma," intended for transatlantic service.

An interesting aircraft which was developed experimentally as a counter to the Zeppelin raids was the "airship-plane" devised by Wing Comm. Osborne. A complete aeroplane was rigged under the envelope of an S.S. airship in such a way that, after patrolling at a great height, the envelope could be released and the aeroplane left free to deliver its attack. After several preliminary flights the first attempt to slip the envelope in flight failed on account, probably, of temporary loss of pressure in the envelope. The machine was partly released prematurely, and was damaged as it fell away; Wing Comm. Osborne and Wing Comm. Ireland were both killed. The former particularly was a most serious loss, as he had up to that time been mainly responsible for the exceptionally rapid airship development.

*Kite Balloons.*—The Drachen kite balloon, in the form originally used by Maj. von Parseval and Capt. von Sigsfeld in 1896, was used by the Germans immediately on the declaration of war for observation of artillery fire. Its value became at once apparent, and it was immediately copied by the Allies, very large numbers being made. The stability was, however, so poor that this type could only be used in fair weather, and accurate observation was often difficult. Capt. Caquot of the French army designed an improved arrangement of stabilizers. Three fins, one at the bottom of the tail and two 120° from it, were in the summer of 1916 ultimately adopted instead of the single fin of the Drachen and the string of parachutes which were necessary with it. Considerably improved stability was obtained, and there was an important increase of the dynamic lift which gave increased height. This type was generally adopted by the Allies for military use and worked well up to 6,000 feet. The same type of balloon was used by the navy, but was replaced by a similar one designed to resist higher wind speeds and capable of only 2,000 feet. This was used extensively by the fleet for gunnery observation and as a look-out for submarines. The balloon, being in continuous telephone communication with the captain of the ship, could transmit information more completely and rapidly than other aircraft. The balloons were also used in the ships protecting convoys, although it was sometimes contended that they acted as buoys to show the position of the convoy to a submarine which could thereby keep in touch at a safe distance during the day and deliver its attack at night. These naval balloons were capable of very high wind speeds, in one instance 80 knots being recorded.

An Italian A.P. type of balloon having a considerably smaller length to diameter ratio was adopted to give very great static lift in calm air. These were used for the apron defence against aeroplane attack. A line of balloons lifted to a height of some 15,000 ft. a horizontal cable from which hung thin vertical wires arranged to foul the wings of the hostile aircraft.

*Airship Operations.*—During the early days of the war French airships were employed for bombing behind the German line, but the damage to the ships, usually through gas leakage caused by shell and bullets, was so great that only a limited amount of work was done.

The Italian airships designed specially for bombing raids at very high altitude across the Adriatic obtained considerable protection from their height, and more useful results appear to have been achieved.

The Zeppelin raids over England were an interesting achievement from the airship point of view. So much of the effect of these raids was indirect, in the delays to munition work during raid nights, large amount of personnel and material retained for defence, and also in the psychological effect produced, that it is

impossible to assess the full value of this work as a warlike operation.

A less well-known Zeppelin activity was the patrol of the North Sea in conjunction with the navy. These patrols were of extraordinary extent and thoroughness, and must have proved a most valuable assistance to the naval authorities. The value of a similarly thorough patrol to the British would probably have been even greater. British airship activity was confined almost entirely to anti-submarine work carried out by non-rigid ships partly as patrols over definite areas and partly as protection to convoys. As a prevention to submarine activity these small ships were extremely effective, although the number of submarines actually destroyed through their direct agency was

small. The use of a hydrophone from an airship while in flight was being successfully developed at the time of the Armistice, and promised greatly to increase the effectiveness of their work. The function of these ships was to detect and keep touch with the submarine until the surface craft arrived with better locating gear and a much more ample supply of explosive with which to carry out the actual destruction. The large ships did a certain amount of scouting work for the fleet, but this operation was really only in course of development at the time of the Armistice. The number of hours flown on patrols was over 87,000 and the distance covered well over two million miles.

One remarkable operation by the Zeppelin L57 was her flight to East Africa for the relief of the German force there. She left

AIRSHIP	Year of Completion	Length feet	Diameter feet	Capacity million cub. ft.	Gross Lift tons	Disposable Lift		Useful Lift		Engines		Speed		Endurance	
						tons	% of gross	tons	% of gross	No	H.P.	Max. knots	Normal Cruising knots	Cruising hrs.	At 40 kts. hrs.
<b>RIGIDS</b>															
<i>Germany:—</i>															
Zeppelin L4	1914	518	49	793	24.1	8.53	35.3	3.3	13.7	3	210	45	32	39	22
L10	1915	536	61	1,126	34.2	14.9	43.5	8.44	24.7	4	240	52.4	38.6	77	70
L20	1916	586	79	1,264	38.4	16.82	46.0	10.0	26.0	4	240	51.4	39.6	80	77
L30	1916	645	79	1,249	39.0	15.2	46.6	17.35	29.4	5	260	55.7	42	93	107
L58	1918	645	79	1,249	39.0	15.2	46.6	17.35	29.4	5	260	55.7	47.4	178	290
L72	1918	743	79	2,420	73.45	47.0	64.0	36.72	50.0	6	260	66.4	49.1	182	330
"Bodenée" (modified)	..	430	61.5	800	22.0	11.1	50.5	8.0	36.3	4	240	68	54	76	165
L100 (design)	..	781	96	3,814	115.8	75.6	65.3	60.1	52.0	10	260	66.6	53.3	180	414
<i>Schütte-Lanz SL3</i>															
SL3	1915	513	65	1,144	34.7	12.18	35.1	6.16	18.0	4	210	45.7	36.5	56	43
SL6	1915	534	65	1,236	37.5	14.58	38.9	8.30	22.2	4	210	50.1	40.1	75	76
SL8	1916	571	66	1,367	41.5	16.0	43.4	11.30	27.3	4	240	50.1	40.1	90	91
SL20	1917	650	75	1,978	60.0	32.86	54.2	23.5	39.2	6	240	59.4	44.3	126	170
<i>British:—</i>															
R9	1917	526	53	.89	25.6	5.1	20.0	1.6	6.25	4	180	36	29	20	..
R23	1917	535	53	.95	27.3	5.6	20.5	1.8	6.6	4	260	45	36	26	18
R32 (Schütte-Lanz type)	1918	615	66	1,553	47.14	16.43	34.8	8.9	18.9	5	250	58.2	46.6	54	85
R34	1919	640	79	1,958	59.5	23.9	44.7	17.2	28.8	5	250	52	41.7	106	110
R80	1920	535	70	1,200	36.43	14.0	38.3	7.81	21.5	4	230	53.9	43	65	81
R36	1921	672	79	2,101	63.8	32.5	51.0	25.5	40.0	4	350	54	43.2	130	163
R38 (design)	1921	695	86	2,724	82.7	52.0	60.5	38.0	46.0	6	350	60	48	157	245
<b>SEMI-RIGIDS</b>															
<i>Italy:—</i>															
O	1918	177	35	.127	3.9	1.37	35.0	.95	25.0	2	120	47	37.6	28	23
M5r	1918	264	59	.441	13.36	6.7	50.1	5.42	40.5	3	200	45	36	69	48
Fortanini 5	1917	298	66	.635	19.3	9.2	47.6	7.39	38.3	3	210	38	30	140	..
Fortanini 6	1918	298	66	.635	19.3	8.64	44.7	6.83	35.4	4	150	47	37	65	47
"Roma"	1920	410	70	1,200	36.3	18.1	50.0	13.0	36.2	6	500	68	53	100	230
<i>Germany:—</i>															
M. IV. E.	1914	400	53	.69	20.9	..	..	6.0	28.7	3	160	43	34	96	59
PL27	1917	526	65	1.12	33.8	..	..	15.0	44.5	4	240	49	39	120	115
<b>NON-RIGIDS</b>															
<i>British:—</i>															
Beta	1912	..	..	.05	1.53	..	..	..	..	1	45	31	25	8.5	..
Eeta	1913	..	..	54.5	1.2	3.63	..	..	..	2	80	35	28	10	..
S.S.	1915	143	27.7	.06	1.82	.5	27.0	..	..	1	70	40	32	..	..
S.S.Z.	1916	143	30.7	.07	2.155	.696	32.3	.435	20.2	1	80	43	35	29	21
Coastal	1915	196	37.2	.170	5.15	1.4	27.0	.9	17.5	1	110	40	32	19	8
Coastal*	1917	220	44.1	.800	6.4	1.93	30.2	1.285	20.1	1	110	51	41	33	22.5
North Sea	1916	262	34.2	.360	11.44	4.34	37.9	3.24	28.3	2	260	50	40	53	36
<i>Germany:—</i>															
PL18	1913	278	49.5	.28	8.5	..	..	2.8	33.0	2	180	38	28	..	..
PL25	1915	400	54	.47	14.3	..	..	6	42.0	2	210	37	30	..	..
<i>France:—</i>															
Astra 19	1919	264	52.8	.336	10.2	4.0	39.0	2.8	27.4	2	250	43.5	35	20	12
Tunisie	1916	307	46	.368	11.4	4.5	39.4	3.1	27.2	2	220	38	30	43	..
Zodiac Veduste	1918	327	35.6	.096	2.92	.9	30.9	.6	20.5	2	80	42	33.5	9	7
<i>America:—</i>															
B	1917	160	31.6	.084	2.55	..	..	8.66	34.0	1	100	41	33	27	16
C	1918	198	42	.180	5.43	1.63	30.0	1.1	20.2	2	150	32	41.5	31	33
D	1920	198	42	.190	5.73	2.12	37.0	1.55	27.0	2	125	30	40	37	37

NOTE.—The trials made with the earlier ships were less complete and less accurate than those made later. The performance was in many instances calculated and recorded on a basis very different from the present standard. The figures given in the table are, however, the best that can be derived from the sources available.

The endurance depends upon the weight available for petrol when a deduction from the useful lift has been made for crew, armament, stores, etc. This deduction necessarily varies with different types of ship, and the basis on which it is made is usually not stated in the records that have been preserved. The endurance should not, therefore, be regarded as a reliable basis of comparison. The figures given are those for the best ship of each class.





**Jimboli (Bulgaria)** at 4:30 A.M. on Nov. 27 1917 with over ten tons of machine-guns, ammunition and medical stores. She had passed Khartum when she was recalled and landed again at Jamboli at 5:30 A.M. Nov. 25, having covered 3,000 m. in 97 hr. with her full load of stores.

The Atlantic flight of R34 was slightly better in point of time. Leaving East Fortune, near Edinburgh, at 1:42 A.M. July 2 1919, she reached New York at 1:54 P.M. on July 6 after 108 hr. 12 min. in the air. The return journey to Pulham in Norfolk occupied only 75 hours.

The longest flight by an N.S. airship was 101 hours. The record for an S.S. ship was 51 hr., equally remarkable when it is realized that the crew of three were continuously on duty.

As indicating the regularity of the patrols, it is interesting that in 1918 from Jan. to Nov. there were only eight days on which there was no airship patrol. As showing the life of a ship, that of Coastal No. 9 at her patrol station in Cornwall may be quoted. She was inflated on July 1 1916, and deflated on Sept. 14 1918. During this 805 days she flew 2,500 hr., or an average of 3 hr. 6 min. per day, over the whole period. The deduction to be drawn from the airship operations carried out appears to be that for future warlike operations their duties will be limited to those areas where intense hostile anti-aircraft fire or hostile aeroplanes are unlikely to be met. With this reservation their uses are likely to be the same as in the past war, with a very important extension to work over undeveloped country, the airships acting as patrols and for the transport of stores. The use of a large airship as a carrier from which fighting or bombing aeroplanes could be released, and to which they could return, was considered. An aeroplane was on two occasions dropped from a rigid airship with no inconvenience or danger to the pilot. Arrangements for the complementary process of hooking on again were not completed at the time of the Armistice.

For passenger and goods transport over distances longer than the aeroplane can profitably cover at one stage the airship has important advantages. By eliminating the time spent at intermediate stops and by flying day and night with the passengers in reasonable comfort, the effective speed over a long journey is probably greater than that of the aeroplane. To this must be added the ability to make long ocean passages in safety and so to select a course as to take advantage of trade winds or local meteorological conditions.

German commercial airship activity was already in 1921 very completely planned and was only suspended by the restrictions of the Peace Treaty. The "Bodensee" had already carried out a remarkable series of flights between Berlin and Friedrichshafen, making 100 flights in 97 days and carrying in all 2,300 passengers. The ship has now been enlarged and a sister ship built in order to extend the flights to Scandinavia. Larger ships and an extension of the service to London and other capitals were contemplated, and a service of ships of considerably larger size from Cadiz to N. and S. America was planned.

**Mooring and Handling.**—The earliest activity of airships had been limited rather by the ability to handle them on the ground than by their ability to meet weather conditions in flight. British Rigid Airship No. 1 was moored by the bow to a mast and sheltered by a screen on Cavendish Dock, Barrow, before the ship was flown. This trial was successful, the ship remaining safe during winds with gusts up to 48 m. an hour. In the course of these trials the screen was abandoned.

The Royal Aircraft Factory in 1912 devised and used continuously for many months a new form of mooring mast to which a non-rigid airship was attached while floating in the air. To prevent the ship overriding the mast in gusty weather and to facilitate approach, the mast carried at its head a swinging cone duly counterpoised, into which the nose of the airship was drawn by a rope running down the inside of the mast. The cone was free to rotate about the axis of the mast as well as to rock vertically on a universal joint and the mast functioned satisfactorily, save that side gusts caused the cone to rub the bows of the ship with a tendency to bend it. These mast moorings were the precursors of one of the great developments in airship use, but till they were adopted generally the airship had to be housed in a shed, and hence the activity of the ship was limited to those occasions when it was possible to take her out in winds of less than 10 or 15 m. an hour with a reasonable chance of rehousing her under equally good conditions.

Under war conditions this restriction was serious, and the method

of the mooring mast was again examined. A non-rigid envelope rigged with a dummy car was secured to the head of a mast at Kingsnorth, first with a cone but later with the cone removed. The ship was reinforced to take the pull of the mast, by fitting inside her bow a spar, the after-end of which was supported by a cone of cords led slightly forward and secured round a circle on the inside of the envelope. The tension in the fabric of the envelope and in these cords held the spar rigidly, and supplied the reinforcement which was necessary for stiffening the bow of the envelope while in flight and also for mooring.

A further set of experiments was carried out at Barrow with a ship secured to a short stump mast, attached to her mooring point and stepped on a lighter. The point of attachment was not on the axis. Indeed, it was so low on the envelope that side gusts produced serious rolling. Accordingly a form was devised in which a somewhat taller mast was fitted with a horseshoe head, so that fittings carried at the top of its arms could be attached to suitably reinforced points aft of the nose of the envelope. This gave support against rolling, but the point of attachment was some distance aft on the ship, and consequently the steadiness was not quite so good as when the envelope was attached by its extreme bow point.

Definitely comparative tests between mooring at the nose, using the spar inside the bow of the envelope and using the horseshoe mast were carried out at Pulham. After considerable time the internal spar of the former broke, for a reason that was not explained, and the horseshoe mast was preferred. As, however, other means were found for mooring the small ships at advanced patrol stations, the horseshoe was little employed.

Mast mooring was, however, realized to be important for rigid airships, and prolonged trials with R24 secured to the head of a mast at Pulham were instituted in July 1919 with success. The ship later remained continuously at the mast for 70 days and experienced winds up to 35 with gusts of 43 m. per hour. Difficulty was experienced in taking the ship to the mast in any but light winds.

Experiments were continued with R33 on Feb. 2 1921, and up to the beginning of June 1921 the ship had worked entirely from the mast. On a few occasions she had been into the shed, but never for more than five days. During April and May 1921 she averaged between four and five flights per week. In this case the mast is provided at its upper end with a single arm, pivoted at its middle point. Down the centre of this arm passes the wire rope, which is attached to that dropped by the ship and by which she is hauled in. This arm, therefore, comes in contact with the bow of the ship before that has actually reached the head of the rigid mast, and gives improved safety as the ship approaches the masthead. Difficulty was experienced with the control of the winch which hauls in the ship's wire. In the experiments with R24 a kite-balloon winch was employed and abandoned owing to its irregular action and control. For the experiments with R33 a steam ploughing engine was used temporarily and found to be satisfactory.

The process of landing to the mast consists in the airship dropping to the ground a rope some 1,000 ft. in length, which is then secured to the rope led from the winch up the centre of the mast and down to the ground. The winch hauls in these ropes and draws the ship to the masthead. There is no difficulty until the ship comes within some 200 ft. of the masthead, but as this distance decreases there is a tendency of the ship to swing both sideways and fore and aft, under the influence of gusts of wind. This difficulty is less serious when the ship is trimmed somewhat down by the stern, so that the wind force on the bow is approximately in the same direction as the tension in the wire. If this arrangement is not made, the variation in the wind force causes swinging of the bow of the ship, and a tendency to override and strike the head of the mast.

Even with the stern of the ship trimmed considerably down, there was still, owing to disturbed conditions, a distinct tendency to swinging, and it was often desirable to employ side-guys led from the bow of the ship to fixed points on the ground, in order to guide the bow to the masthead. With these arrangements, it was possible to secure a 60-ton ship to the head of the mast in winds of 30 m. an hour, with not more than eight men in addition to those actually in the ship.

During the time that R33 was secured to the Pulham mast, an engine was hoisted out and replaced by a spare, and a gasbag was delated and replaced by a spare.

**Three-Wire System of Mooring.**—As an alternative to the system of mooring an airship to a mast, and as a more temporary arrangement, the "three-wire system" was developed from one in which the ship was secured by her mooring-point to the head of a pyramid formed of three cables, the lower ends of which were secured to the points of an equilateral triangle of some 800 ft. side.

The height of the apex was arranged to be between 100 and 200 ft. in order that the downward component of the wires when resisting the wind force should not be excessive. A considerable weight of wire was, however, necessarily supported by the ship, and a large amount of static lift was therefore necessary. This system gave considerable success during 1918, but was found defective in gusty winds, owing to the liability of one wire going slack under the influence of side gusts. A wind along the axis of the ship produces a certain amount of dynamic lift which balances the downward component due to the tension in the wire. The force caused by a sideways gust produces no corresponding increase of dynamic lift, and

there is, therefore, a tendency for the lee wire to go slack. When the gust ceases and this wire draws taut, a serious impulse is brought on the bow of the ship.

It was also found that the wires of this system were so nearly horizontal that they fouled the car of R.33.

To overcome these difficulties, a running system was devised. Various alternative forms were tried giving varying degrees of rigidity of support. The final system which has been found most satisfactory is that shown in fig. 26. This has the additional advan-

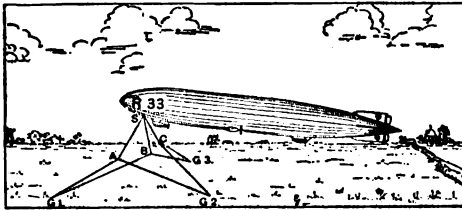

G. I. G. S. Denotes swivelling Pulley attached to Ground Bollards  
S. Denotes Mooring Point, A, B, C. Denotes Rings.

FIG. 26.

tage that only the comparatively short wires, SA, SB, and SC, are carried in the ship, the remainder of the wires lying on the ground and being picked up when the ship lands. Complete experiments with this system have not been carried out, but it is considered that a ship could withstand any ordinary wind forces when secured in this way. She would be much more difficult to secure in this way than to a mast, and could not be easily supplied with water ballast, fuel or additional gas.

In order to meet the greatly increased requirements for small airships for anti-submarine patrol during the war, a system of mooring-out grounds was developed. These mooring-out stations were formed by making clearings in suitable woods and cutting a comparatively narrow avenue through the wood to the clearing. Small airships were secured in these clearings, and re-fuelled and repaired in exactly the same way as in proper sheds. The protection was so good that ships have been totally undamaged even though winds of 60 m. an hour were blowing over the top of the wood at the time.

**Airship Sheds.**—The construction of airship sheds has been an important item in the expense of airship work. The cost of the shed increases very rapidly with height and with the span, both of which must be considerable with any but the very small ships. Apart from the cost of the shed, there is considerable difficulty in taking a ship into the shed in any but very calm weather. When a wind is blowing across the mouth of the shed, the airship has to be hauled broadside on to the wind in order to pass in through the door, and this represents a very difficult operation when the wind is of considerable strength or of a gusty nature. In order to afford protection during this operation, all early airship sheds were provided with wind-screens running from the corners of the shed outwards parallel to the axis. These screens were of a height nearly equal to that of the shed, and afforded considerable protection against the horizontal force of the wind. They, however, caused a serious eddy to be formed, which produced a vertical disturbance on the ship nearly as difficult to overcome as the horizontal force which would have existed had there been no wind-screens present. Experiments were carried out with the wind-screens formed of expanded metal, and with screens of corrugated iron in which 30% of the sheeting had been omitted. These screens, although they reduced the horizontal wind to a smaller extent than the solid screens, avoided the serious vertical air disturbance and were, for that reason, considerably preferable.

Experience in Germany had, however, shown that a system of rails provided with easily running trolleys was the most satisfactory system of supporting the ship against sideways forces. These rails ran out from the corners of the shed parallel to the axis, and the side-guy of the ship were attached to trolleys running on these rails. The support of the ship obtained in this way is so good that wind-screens are rendered unnecessary, and the vertical air disturbance connected with them is thereby avoided. Even with this system of handling rails, the housing of an airship presents considerable difficulties. A landing party of several hundred men is required to receive a 60-ton airship on the landing ground, to carry her to the end of the handling rails and to haul her round parallel to the rails. The air in the neighbourhood of the shed is necessarily so disturbed that considerably greater difficulty is experienced near the shed than when on the open landing ground or in the neighbourhood of a mooring mast. The difficulties connected with airship sheds are, therefore, considered to be so great that the shed must only be regarded as the dock, the mooring mast being regarded as the normal method of securing an airship between flights.

When secured to the mast the airship can be supplied with gas, water ballast and fuel. The passengers can be passed up the mast by a lift and can walk through the bow of the ship down to the cabin. The airship appears to behave satisfactorily in any wind. The most

difficult conditions to meet are those in which there is no wind but rapid changes of temperature which affect the lift of the ship. This necessitates rapid adjustment of the ballast in the ship by taking in or discharging water. As long as there is a considerable wind the trim can be regulated by the elevators, as in flight.

Attempts have been made to anchor a ship to the ground by a single wire. This operation would have considerable advantages for a ship which became broken down and required to avoid drifting with the wind. At sea a drogue can be lowered into the water, and the ship will ride to it satisfactorily provided she is correctly trimmed some five degrees up by the bow in order to derive the necessary dynamic lift. It is, however, necessary to steer the ship continuously, while secured in this way, exactly as though in flight. Anchoring to the ground is a considerably more difficult problem. A grapnel cannot obtain a sufficiently firm hold to resist the impulsive upward-pull in the airship trail rope. Experiments were carried out with a form of dropping grapnel consisting of a large, suitably shaped weight dropped from a height of some 200 feet. This grapnel obtained a satisfactory hold either on very hard ground or on soft ground where the penetration was very deep. The hold was, however, quite unyielding, and the shock produced on the ship when thus checked was far too serious. Various forms of friction device to allow a gradual check to be brought on the ship were tried, but were never found sufficiently satisfactory for adoption.

**Towing.**—The earliest test in connexion with airship towing is perhaps the most interesting one. Naval Airship No. 2 broke down about 40 m. from Farnborough, and in order to save the loss of gas and the probable damage to the ship that would have attended her deflation, she was towed home by another airship, "Eta," of a slightly greater size. The operation presented no difficulty whatever. "Eta" landed alongside the damaged ship; a wire some 600 ft. in length was laid out between the two ships; both ships were made light and allowed to rise into the air. The towing ship then went ahead slowly and towed the disabled one back to Farnborough.

Occasion for repeating this towing operation has not since presented itself, but the complete success which attended the first attempt indicates that there is no serious difficulty in connexion with it. It is probable that for certain special purposes, where large weights have to be carried and where speed is not of great importance, the towing of one or more "air barges" by an airship presents very interesting possibilities.

**Naval Towing.**—Various trials were made to determine the possibility of towing an airship to the scene of operations so that she should arrive there with her full supply of petrol still available.

In May 1916 a Coastal airship was, after a few preliminary tests with a motor launch, towed by a light cruiser steaming at 26 knots up, down and across a wind of some 15 knots. In a further trial the airship was hauled down to the deck of the cruiser and the crew changed and gas and fuel supplied. The same operation was carried out at a height of 150 ft. to provide for occasions when the sea was too bad to allow the airship to be brought close down. These trials were entirely satisfactory.

In Aug. 1918 a ship of the S.S. class carried out extended trials in tow of a submarine. These caused no difficulty except that it was desired to make the ship capable of being towed without a crew. Arrangements for the automatic maintenance of pressure and the greater degree of stability required caused the extension to this much more difficult operation to be abandoned.

In Nov. 1918 the towing of an S.S. ship by a destroyer was again actively being developed with a view to replacing kite-balloons by airships for convoy work. In Aug. 1919 N.S.7 carried out a long towing operation with the fleet. She was in tow continuously for some 40 hrs., and was gassed and refuelled in a wind of 30 knots.

The conclusion to be drawn from these tests is that an airship can be towed without difficulty provided she is steered and handled as in flight. The towing is little relief to the crew, but the expenditure of fuel is avoided. The crew can be changed and fuel and gas can be supplied in reasonably fair weather.

**Airship Fabrics.**—The outer cover of a rigid airship has to form a smooth fairing over the hull structure and gasbags. Unless it remains taut under all conditions the passage of air over it and more particularly the disturbed air in the vicinity of the airscrews gives rise to flapping, which not only increases the ship's resistance but may cause the cover to chafe and ultimately be torn. The tautness is produced and maintained by a dope, applied to the fabric partly before and partly after the sheets of fabric are laced to the hull framework. The dope is generally similar to that used on aeroplane wings, but the unsupported expanses of fabric are so large—usually 5 metres by 5 metres—that the prevention of flapping is a much more difficult problem; indeed, these surfaces are so large that the maintenance of a correct difference of pressure between the inside and the outside of the ship is more effective than exactly correct tautness. The weight of the outer cover is such a large proportion of the total of the ship that very great care must be taken to apply only the minimum of dope necessary.

The outer surface must be made reflecting in order to reduce as far as possible the amount of radiant heat absorbed and transmitted to the gas in the cells and the air inside the hull.

The pigment or dye employed in the dope must be such that the part of the light which most rapidly deteriorates the cellulose of the



gas cells is eliminated as far as possible. A certain amount of light is necessary in the keel, and this usually enters through the bottom two strokes of outer cover on which a transparent dope is used. The surface of the dope should be water-repellent in order to reduce the weight of water taken up in a rainstorm.

The fabric usually employed for the outer cover is linen weighing about 90 grms. sq. metre, although cotton, mercerized as thread before weaving, appears to have some advantages owing to its great uniformity of contraction when doped.

Gasbag fabric must primarily have good gasholding properties for the minimum weight. The strength need only be sufficient to withstand handling when the bags are being placed in the ship or are moving slightly with change of fullness.

Goldbeaters' skin—the thin membrane from the caecum of the ox—although easily permeable to moisture is extremely gastight when in good condition. The skins vary in size, but, allowing for overlaps, each skin covers about 10 in. by 4 in. In English gasbags the skins are attached to the fabric by rubber solution, as this gives rather better gastightness for a given weight. The German method is to build up the skins into large sheets some 10 metres wide and of length equal to the circumference of the bag. Fabric is then stuck to these sheets with a form of gelatine adhesive. Skin contracts as it dries, whereas fabric contracts as it absorbs moisture; great care has, therefore, to be taken that the fabric is attached to the skin sheet under correct humidity condition. The fabric in which rubber is used as the adhesive is found to give trouble in hot climates, owing to the serious contraction of the skins and the softening of the adhesive just when good adhesion is most essential.

German experts are strongly of the opinion that the use of rubber in gasbags forms a non-conducting surface apt to become electrically charged by friction or in the vicinity of an electric storm. The use of rubber has, therefore, been abandoned in Germany since very early days.

Fabric made with glue adhesive appears satisfactory even under the most extreme tropical heat.

The envelope fabric of a non-rigid or semi-rigid ship, in addition to being gastight, must have an outer surface capable of giving protection against light and heat. It is also called upon to take very considerable tensile stresses. These are due partly to local tensions in the neighbourhood of rigging attachments; partly to a bending of the envelope as a whole, but mainly to the internal pressure which is necessary in order to maintain the shape of this class of ship. When the ship takes up a steep angle of pitch there is considerable accumulation of pressure at the upper end, and if for any reason, such as a rapid rise, the pilot allows the pressure to become excessive the tension in the envelope is more likely to approach the safe maximum than from any other cause. The tension induced by internal pressure is, therefore, the main consideration and must be regarded as a load that, although not very suddenly applied—the interval between normal and maximum being at least 15 seconds—cannot be expected to be maintained for long periods—any, more than 15 minutes. The resistance of fabric to tension varies greatly with the rate at which the load is applied. For a high rate of loading—say, 150 lb./sq. in./min.—the load reached before failure is 10 to 20% higher than the load reached with the comparatively slow rate of 30 lb./sq. in./min. or less. A load sustained for really long periods gives lower strength still. A load of only 50 to 60% of that which the material will stand for, say, 10 minutes will break it after a week.

Considerably more investigation on these points is still required, but they are probably due to the manner of failure of a woven material, being one of gradual slipping of the fibres of the twisted thread.

A small local cut produces considerable reduction of tensile strength of an ordinary fabric. This is due to the concentration of stress at the ends of the cut causing the failure of individual threads in succession. Provided the cut is more than 1/4 in. long across the direction of tension the reduction of strength is to some 30% to 40% of the unwounded strength and is no greater until the size of the cut is such that it becomes an important proportion of the whole width of fabric in tension. In order to reduce this loss of strength fabric exposed to serious tension is usually made of 2 or 3 plies, of which one has its threads at 45° to those of the other plies which lie along and normal to the direction of tension. The threads of the diagonal ply help to redistribute the concentration of stress at the ends of the cut. The extent of this reinforcement depends upon the comparative strength of the diagonal ply and upon the nature of the material with which the plies are stuck together. The table shows with an accuracy of about 5% the wounded and unwounded strengths of typical airship fabrics built up of one or more plies of the same cotton and expressed as percentages of that of single ply, the adhesive being in each case rubber.

Fabric	Strength unwounded	Strength wounded
Single ply	100	40
2-ply parallel	210	70
2-ply diagonal	125	90
3-ply parallel	315	110
3-ply centre-ply diagonal	240	120

Rubber is particularly suitable as a doubling adhesive as it allows

the requisite movement of threads for the reinforcement to take place. Glue, being a much more rigid adhesive, will allow of practically no reinforcing action by the diagonal ply.

Rubber is also a reasonably good gasproofing material and as it combines these two qualities it is almost universally employed in the construction of non-rigid airship envelopes. The fabric used for the envelopes of the U.S. airship was made of three plies of a cotton weighing 80 grms./sq. metre. The outer surface as a protection from light and heat was of 30 grms. of rubber containing a proportion of black litharge and a surface of aluminium powder. Between the outer and diagonal ply was 30 grms. of rubber and between the diagonal and inner ply 100 grms. of rubber as a gastight layer; some more recent experiments show that additional protection is given to the rubber by staining it with a suitable red dye.

Gastightness of most materials decreases considerably (4 or 5% per degree Centigrade) with increase of temperature.

A film of gelatine gives the greatest gastightness for a given weight, but its protection against the effects of moisture is a matter of considerable difficulty which has only recently been achieved with any degree of success in compound films now being developed.

Goldbeaters' skin is almost equally good, but is liable to small local defects caused in the process of preparation and building up.

An extract of the plum, *sordida myza* or Turkish birdlime, has given satisfactory results in some respects, but its use has not been very fully developed.

It is important to realize that gastight fabric for airships must primarily stop the leakage of air into the gas. Loss of hydrogen is too small to be important, but the ingress of a weight of air definitely reduces the useful lift of the ship by an equal weight and this can only be partially got rid of even by the discharge of many times the volume of gas.

**Airship Machinery.**—In the early days the machinery of airships and aeroplanes had to be extremely light. As development proceeded, the greater weight of light of the airship made fuel economy and some other characteristics of great value in the airship than in the aeroplane. In England neglect of airships before the war followed by difficulties of supply during the war caused the airships to use, not a special engine suitable for this requirement, but standard aeroplane engines. This general unsuitability of the engines used for airship work caused the machinery to be by far the most unreliable part of the airship as a patrol unit.

The advent of the commercial aeroplane for long flights is in turn bringing a requirement more nearly that of the airship. Even so, an aeroplane which flies 10 hrs. before refuelling must be compared with the airship which flies 100 hrs. on one load of fuel. A machinery installation which weighs, say, 5 lb. per H.P. burns 0.5 lb. of fuel per H.P. in one hour. An aeroplane in 10 hrs. will burn a weight of fuel equal to that of its machinery. In 100 hrs. an airship will burn ten times its machinery weight. The importance of saving fuel even at the expense of increased machinery weight is therefore much greater in the airship. During much of the airship's flight some engines are run at considerably less than their full power, thus introducing the need for good fuel economy at reduced power. In an airship repairs of some magnitude can be made in flight (a cylinder has been changed, crankshaft water-jackets, packed, magnets changed and retimed, etc., during long flights). The machinery must therefore be arranged so that advantage can be taken of this possibility.

**Arrangement of Power Units.**—The low speed of an airship renders desirable a larger airscrew than in the faster aeroplane. Moreover, airscrew size is not restricted by the consideration of landing as in the aeroplane. The large airscrew makes for fuel economy, and this being cardinal has been found to justify the use of reduction gearing. The most efficient arrangement for a rigid airship includes a fly-wheel fitted to the crank-shaft of the engine driving, through a friction clutch, a gear reduction box on which is mounted a large two-bladed airscrew. In R38 350 B.H.P. is transmitted through a 3.3:1 reduction gear to a 17½-ft. airscrew, turning at 600 revs. for a ship's air speed of 60 knots. There is usually, in addition, a dog clutch and an airscrew brake, so that the airscrew can be disconnected and locked horizontal when landing. The departure from aeroplane practice is here notable.

In early airships it was usually necessary to mount the engines in the car and to transmit the power to airscrews carried on outriggers. The weight available for this transmission was so small that there was frequent trouble, which could mostly be traced to resonance at some speed within the very wide range (often from 100% to 50% of the revolutions for full speed) over which the airship engine was driven.

Belts, chains, bevel-gear boxes with long lengths of shafting were used, but all gave trouble within a few hundred hours' flight.

German rigid airships derived great benefit from the Maybach engine, which was developed at the same time as the ship's designs progressed, and was devised primarily to be suitable for airship purposes. It departed from other aero-engine practice in many respects, and though it was not till quite late in the war that a modified type of a Maybach was used in aeroplanes, the German industry gained the earliest experience of large light-weight engines.

In the British airships constructed during the war there was no intermediate shafting, the airscrew being mounted on the engine.



In some cases a reduction gear was incorporated in the engine itself. In the first ships of the N.S. class a length of shafting was used in order to give a better shape to the engine car and obtain better airscrew efficiency. This shafting had ultimately to be abandoned on account of torsional resonance, and the airscrew mounted direct on the engine. In the German rigid airships, however, where more weight was available, the reduction gear box and intermediate shafting were employed.

Pre-war British airships and the first few rigidids were fitted with swivelling propellers. The airscrews were carried at the ends of horizontal arms and driven through bevel gearing so that the axis of the airscrew could be rotated about a horizontal transverse axis, and the direction of thrust of the airscrew changed from ahead to astern, up or down. The ability to exert a vertical force independent of the headway of the ship was often very valuable to the then comparatively inexperienced pilots under the bad landing facilities then existing.

Though engine failure has not the same consequences as in an aeroplane, the machinery must still be regarded as the part of the airship most frequently in need of overhaul. Experience shows that the engine cars must be easily detachable so that spare cars can be fitted and through overhaul made possible without excessive delay to the ship. They must be as the locomotive to the train, not as the machinery to a battleship.

**Hydrogen as Fuel and Recovery of Exhaust Water as Ballast.**—During a long flight the consumption of petrol so reduces the weight of the ship that, in order to restore her static equilibrium for landing or to avoid the increase of resistance if she is flown very light, it is necessary either to discharge a quantity of hydrogen or to acquire weight. The latter can be done by condensing the steam in the exhaust gas. Petrol produces steam equivalent to some 140% of its weight, and the proportion of this which can be collected depends upon the temperature and humidity of the issuing gas. The chief difficulty in the condensation is due to the fouling of the cooling surfaces with an oily deposit.

Attempts have been made to burn, as supplementary fuel, the hydrogen, which must otherwise be discharged. When burning hydrogen alone in an engine with a compression ratio of about 3:1 it is not possible to develop more than 25% of the engine's full power without serious detonation. When petrol and hydrogen are burnt together the proportion can be so adjusted that any fraction up to full power can be developed. A few of the smaller airships were fitted in this way but the system was abandoned on account of increased risk of fire.

**Risk of Fire.**—Apart from hostile incendiary action the risk of fire in the air is small and is mainly due to the petrol. It is thought that the use of heavy oil fuel would give added safety. The heavy oil engine at present involves prohibitive weight, but a Diesel engine capable of burning only 38 lb. of fuel per H.P.-hour would, on the basis of 100 hrs. flight, justify an increase of machinery weight of 12 lb. per H.P. over the 5 lb. per H.P. of the petrol machinery which burns 5 lb. per H.P. hour.

**Winches (for Kite-Balloons).**—The earliest form of winch used had a steam engine driving a single drum on which the wire was wound. It was mounted on a single chassis and was drawn by horses.

In 1915 the French adopted a steam winch of Col. Renard's design which was fitted with surge drums—a pair of drums round which the cable makes a number of turns in grooves of correctly formed section. These drums transmitted the whole of the engine or brake torque to the cable and allowed it to be stowed on a separate storage drum under comparatively small tension and, therefore, less subject to damage. The winding unit of this type of winch, including the surge drums, liquid brake and storage drums, was adopted, with only modifications in detail, as the standard for all future winches.

The later winches were usually driven by petrol engines independent of the motors driving the chassis which carried them.

After 1916 the German winches were made in two separate units, the motor on one and the winding unit on the other. These were treated like gun and limber and when in use were connected by a flexible shaft.

For naval purposes the standard winding unit was employed but driven by a steam engine in destroyers, an electric motor in light cruisers, and by hydraulic motor in capital ships, these being the most convenient forms of power available.

**Gas for Airship Purposes.**—Hydrogen is almost invariably employed for airships and balloons. Coal gas is cheaper and more universally available. It is sometimes used for free ballooning, but has a lifting power of only about half that of hydrogen. Helium, although having only 93% of the lifting power of hydrogen of equal purity, is totally non-flammable and has, therefore, signal advantages for airships exposed to attack with incendiary bullets.

**Variation of Lift.**—The total upward force on the airship when at rest is termed her "gross lift." If  $V$  be the volume of gas in the ship,  $\rho$  its density and  $\rho_a$  the density of the surrounding air:

$$\text{Lift} = V(\rho_a - \rho).$$

**Variation with Height.**—The lift is constant as the ship ascends until a height—termed "the pressure height"—is reached at which the gas spaces have become full and further expansion involves the loss of gas. When descending, the lift will similarly remain constant,

because  $V$  varies directly and  $\rho$  and  $\rho_a$  inversely as the height, assuming that the temperature of gas and air remain equal. As the ship rises above pressure height,  $V$  remains constant but  $\rho$  and  $\rho_a$  decrease.

**Variation with Barometer** is nil until the ship becomes full; after that it varies directly with the barometric reading.

**Variation with Temperature.**—Provided the temperature of the gas exactly follows that of the surrounding air, there will be no change of lift until the ship becomes full. Then, after  $V$  has reached a maximum the lift will decrease inversely as the absolute temperature rises. Radiant heat falling on the ship raises the gas temperature sometimes as much as 40° F. and often 20° F. above that of the air. The gas temperature changes comparatively slowly as the ship moves through air of varying temperature, hence there may be a considerable difference between gas and air temperatures and this will substantially influence the lift of the airship.

**Variation with Gas Purity.**—Dilution of the hydrogen by ingress of air increases  $\rho$  and decreases the lift.

**Standard Basis of Airship Calculations.**—The variation of atmospheric density with height is a somewhat complex relation. The accepted relation is given in A.C.A. Reports, R.M. 509. The conditions at sea level are assumed to be: atmospheric density—0.782 lb./ft.<sup>3</sup>; temperature 282° A.; pressure 1,014 millibars, i.e. 14.7 lb./in.<sup>2</sup>. As a standard basis of calculation of airship performance, the lift of hydrogen under these conditions at sea level is assumed to be 68 lb. for each thousand cubic feet. This figure corresponds to a purity of 94 per cent.

**Determination of Purity.**—The apparatus most usually employed measures the times taken by equal volumes of gas and air to escape through a small hole. The densities are inversely proportional to the squares of these times. An accuracy of  $\pm 1\%$  can be obtained with such an instrument.

The most accurate method is by chemical analysis.

**Manufacture of Hydrogen.**—The choice of method is governed primarily by the transport facilities and the raw materials available in any district. Those most usually employed for airship purposes are:—

**The Water-Gas Process,** generally employed at large fixed bases where a supply of coke is available. It yields a steady supply of gas of about 99.0% purity. Calcined spathic iron ore is oxidized at about 800° C. by steam. Hydrogen is given off and the ore is then reduced by water-gas and the process repeated. In the Lane plant the ore is contained in iron retorts heated externally by coke or spent gas. In the Messerschmidt plant the heating gas is burnt actually in contact with the ore itself.

**The Electrolytic Method** is employed where cheap electric power is available or where the oxygen is valuable as a by-product. Distilled water must be used and a yield of 5 to 7 cub. ft. of hydrogen per kilowatt hour with a purity of over 99% can be obtained.

**The Silicon Process** is employed where a rapid yield is required and where transport of raw materials is difficult. Powdered ferro-silicon (90% Si) is fed into hot 40% caustic-soda solution. One ton ferro-silicon and 2 tons of caustic give about 50,000 cub. ft. of gas of 99% purity.

In cases where transport of materials is exceptionally difficult, hydrolytic (the calcium hydride made by passing hydrogen over strongly heated metallic calcium) is used with water. About 34,000 cub. ft. of hydrogen are given off per ton of hydrolytic.

**Storage.**—Hydrogen is usually stored in gas-holders under a pressure of some 9 in. of water. It is transported in steel cylinders under a pressure of some 2,000 lb./in.<sup>2</sup>. One ton of cylinders will carry some 2,600 ft.<sup>3</sup> of gas at N.T.P. In Germany special Kesselwagen (tank trucks) carried 2,600 cub. ft. for a weight of one ton of tank (see T. A. Monckton, *Hydrogen Manual*, Parts 1 and 2, H. M. Stationery Office).

**Helium.**—Helium is present in the atmosphere as 0.004%. It is present in certain natural gases in proportions up to 2.5%. The main supplies are, however, in the natural gas in Texas, where the strength is about 1.8%, and in Canada, near Ontario, where the purity is .3%. The process of collection is by liquefaction of the gas and by regenerative distillation. The cost, therefore, varies almost inversely as the proportion of helium present in the gas. The cost of production in a large plant working in America is about £12 per 1,000 cubic feet.

Such technical detail as has been published is contained in:—*Reports to the Advisory Committee for Aeronautics and Reports to the Aeronautical Research Committee*; lectures to the Royal Aeronautical Society, published in *Aeronautical Journal*; two lectures to the British Association in 1919 and 1920; lecture by Air Commodore Maitland to the Royal Society of Arts; T. A. Monckton, *Hydrogen Manual*, Parts 1 and 2 (H. M. Stationery Office); various articles in the German aeronautical press, mostly in *Illustrirte Flugwoche*, *Luftweg* and *Luftfahrt*; in the Italian in *L'Aeronautica* and *Gazzetta dell'Aviazione*, and in the French in *L'Aeronautique*.

(C. B. C.)

**AEROPLANE:** see AERONAUTICS.

**AEROTHERAPEUTICS.**—The term "aerotherapeutics," as a special branch of medicine, might convey the idea that there are special diseases due to aviation which require special treatment.

But such is not the case, as there is no special "flying sickness" brought about solely by the pursuit of aeronautics. Although certain authorities have inclined to recognize some mechanical effects owing directly to the reduction of atmospheric pressure upon the body, this is only of importance in connexion with the air enclosed within the cavity of the middle ear and to a lesser extent as regards gas inside the intestines. Changes of absolute pressure of the atmosphere produce no mechanical effects since the altered pressure is transmitted equally in all directions through the semi-fluid body tissues. The suggestion has also been made that, owing to the diminution of atmospheric pressure, the airman may be liable to a special disease, somewhat akin to that experienced by the diver or the worker in compressed air. The cause of "diver's palsy," "caisson-disease," or "compressed-air illness" is now thoroughly well established. When man is subjected to an increased air pressure he dissolves in the fluid portion of his blood a considerable amount of nitrogen from the surrounding air. When the air pressure is diminished, this nitrogen is again given off. If the diminution in pressure be rapid, then bubbles of gas are liberated inside the blood vessels, in the same way as bubbles of gas are liberated when fluid is removed from a siphon of aerated water. These bubbles then circulate in the blood and produce symptoms, according as they become lodged in the various parts of the body.

At first sight, therefore, it might be supposed that an airman making an ascent, in other words subjecting himself fairly rapidly to a diminution of the surrounding air pressure, might be liable to symptoms arising from the same cause as does "diver's palsy." This, however, is not the case, since the diminution in pressure is not sufficiently great or rapid to bring about any liberation of gases held in the blood plasma. In "diver's palsy" and "caisson disease" one is dealing with a reduction of pressure of from two to five atmospheres, whereas in flying one is generally dealing at most with a diminution of pressure of a little more than half an atmosphere, which is reached relatively slowly, and is easily within the margin of safety for the rate of decompression in compressed-air work. The idea, therefore, that airmen are subject to any special "flying sickness" of this nature may be dismissed.

Because it is stated that there is no "flying sickness" it does not mean, however, that flying may not cause bodily breakdown. Flying imposes a very definite stress upon the body, especially when flights are carried out for long periods at high altitudes. When to this is added the stress of offensive and defensive warfare in the air it is obvious that bodily breakdown as the result of "strain" is likely to ensue. But the signs and symptoms of "flying strain" are varied and might occur in an individual quite apart altogether from flying. In the World War it was found that "flying strain" was most generally characterized by a gradual loss of power to fly high, associated in varying degrees with symptoms of respiratory, cardiac and nervous derangement, such as breathlessness on exertion, quickened heart-beat, exaggerated reflexes, marked tremor of fingers and eyelids, and loss of neuromuscular control as exemplified by power to balance on one leg. Mental symptoms, generally in the form of anxiety neurosis, might or might not be present. In many cases it was difficult to say whether breakdown was to be attributed primarily to the effects of flying or to the nervous strain of aerial warfare, but such symptoms were frequently found to occur in those who had taken no part in active service in the air.

In order to appreciate the correct medical measures which must be taken in respect of the care of flying personnel, it is necessary in the first place to consider the human machine in relation to flying. The aviator provides the controlling and coordinating mechanism on which the satisfactory performance of the aeroplane depends. The pilot adds the aeroplane to himself—the "joy-stick," engine controls and so forth are appendages to his hands, the rudder bar an extension to his feet. By appropriate movements of his upper and lower limbs man is now able to fly, just as previously by appropriate arm and leg movements he was able to indulge in games or to control other forms of mechanism, as, for example, a motor-car.

To acquire the art of flight, therefore, a number of controlled and coördinated movements are necessary. It is common experience that certain people are found heavy-handed or heavy-footed and not likely to acquire the art of flying. In the apt pupil these coördinated movements are at first all made as the result of conscious effort, but later they pass into the realm of the automatic, so that eventually the expert pilot does not have to think how he flies—he just wishes his machine to perform a certain evolution and it occurs.

No elements come into the mechanical problem of flying that are not required for driving a motor-car or taking part in various sports; some men have mere aptitude for flying than others, just as some have more aptitude for games.

To initiate the coördinated movements necessary for flying, the pilot relies upon certain sensory impressions. Vision is the most important. Without facilities for using his eyes a man is not able to fly. It has been found that experienced pilots cannot satisfactorily perform even a simple evolution with the eyes blindfolded. It is also well known that pilots cannot fly level in fog and may even get upside down. This is due to the temporary eclipse of the sense of vision; unaided by instruments, man will never be able to fly in a fog successfully.

Besides good visual acuity it has been found that harmonious working of the muscles moving the eyeballs is necessary, particularly for successful landing, and is lacking in a great percentage of bad landers. By careful training it has been found possible to bring about good visual judgment of distance and to turn bad landers into good ones.

For successful flying, next to vision and perhaps almost equally important, come the sensations from the skin and muscles. A pilot flies very largely by the "feel" of his machine. In addition to the "feel" of the controls, he derives much information from the "feel" of his seat, from the direction and change of direction of the wind on his face. He is also aided by hearing the singing of the wind in the wires. Hearing is of importance also in flying in so far as it enables a pilot to detect a falling engine, to operate wireless and to hear a telephone above the roar of the engine.

According to some people it has been thought very necessary that a man should have a good sense of balance, but experience has shown, as already mentioned, that "balance sense" is not sufficiently developed in any man to enable him to fly level in a fog.

But for flying it is not sufficient to be endowed with a mechanical and mental aptitude; a consideration of prime importance is physical endurance to resist the stress of high flights or flights of long duration. For endurance it is particularly important that a man be fit as regards his respiratory and circulatory mechanisms. This has been shown by the examination of fit pilots as well as of subjects who have been deemed in need of a rest or who have broken down as the result of flying strain.

The examination of successful flying officers showed that they were possessed of an efficient respiratory capacity. The examination of officers taken off flying through "flying strain" showed that their capacity was very much diminished. It was found by careful observation that this fall was due chiefly to ineffective working of the "exhaust" or expiratory side of the respiratory "bellows." The individual had lost his power to expire fully to the greatest extent. He, therefore, could not empty his lungs satisfactorily. Such a condition makes for deficient ventilation and the subject becomes very like a motor-engine in which the exhaust valves are defective and incomplete scavenging of the cylinders results. Hence we find that the airman in this condition easily gets breathless on the ground and certainly cannot fly to heights at which formerly he did not notice anything abnormal in his breathing.

For endurance and high flying, therefore, it is especially important that a flier have an adequate "bellows capacity" and that the "bellows" be particularly effective on the exhaust side. An efficient expiratory force is, therefore, very necessary to the pilot.

Examination of successful flying officers also showed that the effective pilot is possessed of an efficient circulatory system.

Observation has shown that there is a marked difference between the fit and unfit pilot in this respect. For example, the fit pilot is possessed of a regular, fairly slow pulse which gives the impression of a delightfully easy-working piece of mechanism. It is not greatly quickened by exercise and speedily returns to its normal rate. The pulse of the man unfit for flying, or unfit to learn to fly, is unduly quickened by exercise and takes considerable time to return to normal.

Circulatory efficiency also depends upon the pressure maintained in the arteries both during and between the beats of the heart. With the beat of the heart the pressure in the arteries rises; during the rest period it falls. In some people it may fall greatly, in others but a little. The examination of successful flying officers has shown that in them the fall is not great, whereas in the tired or inefficient individual the difference in the pressure during and between the beats is relatively large. The importance of a good pressure between the beats will be appreciated when it is realized that if the fall of pressure be great enough, fainting may result.

The efficiency of the circulatory mechanism of the body is intimately bound up with the efficiency of the respiratory mechanism. The abdominal cavity has sufficient vessel capacity to take the whole of the blood of the body and, in the upright or sitting posture, blood, by virtue of the effect of gravity, will tend to stagnate there unless its return to the heart is aided by the movements of respiration. In inspiration the downward thrust of the great muscle separating the chest from the abdomen, the diaphragm, acts like the piston of a pump and squeezes blood upwards into the heart, since it is prevented from escape in any other direction by means of valves placed in the vessels. During expiration the muscles of the abdominal wall and of the lower ribs squeeze inwards upon the abdominal contents and again force blood upwards to the heart.

The importance of these accessory pumps to the circulation is well exemplified in the crucifixion of a man. In the vertical posture the immobilization of the limbs and the restriction of the action of the respiratory and abdominal muscles cause blood to stagnate in the lower limbs and the abdomen, thereby contributing the principal cause of death.

Since in the machine the pilot is rendered relatively immobile in a sitting posture, it is of the greatest importance that he be possessed of efficient respiration and good abdominal tone, in order that an adequate circulation may be maintained. The importance of good abdominal tone is further emphasized by the following experiment. If a hutch rabbit, with its flabby, pendulous abdomen, be held in the vertical posture, it will soon become unconscious owing to the lack of tone of its abdominal wall; a wild rabbit, on the other hand, will not do so, owing to the fact that, on account of the exercise taken in its free open-air life, it has developed the tone of its abdominal musculature.

This emphasizes the value of sport in developing the respiratory and circulatory mechanisms, and for this reason all airmen are advised to take up sports which, besides giving eye and limb coordination, also give physical endurance by toning up the respiratory and circulatory mechanisms. The importance of sports and games in the life of the flying man cannot be over-emphasized.

In addition to the power of endurance the pilot must also be possessed of quick perception and judgment, which, besides enabling him to learn to fly, will help him to meet any sudden emergency which may arise while he is in charge of his machine in the air. He must therefore possess good mental and nervous stability. Such stability is of even greater importance in the service pilot who may be called upon to undertake combatant service in the air.

Since 1878 it has been known that the chief cause of "mountain sickness" or "altitude sickness" is lack of proper oxygenation of the body owing to the rarefaction of the air breathed. Experiments conducted in rarefaction chambers as well as at high altitudes, such as Pike's Peak and Monte Rosa, have fully proved this point. In respect of life at high altitudes, however, a certain degree of bodily acclimatization takes place, which is

not the case in respect of flying. In an aeroplane the length of sojourn at high altitudes is insufficient to induce any acclimatization, beyond possibly a transitory concentration of the blood plasma. In flying the effect of increasing altitude is in the first place a deepening of the respiration in order to secure the oxygen necessary to maintain the bodily functions. At the same time the heart quickens, and thus is established the beginning of a "vicious circle." For an increase in the rate of the heart-beat means an increase in the amount of work done by the heart, and this increased work entails an increased oxygen consumption, the supply of which is diminishing; thus each factor reacts unfavourably upon the other.

All the devices to render the respiration and circulation efficient will, therefore, be called into play to meet the changing conditions, so that with prolonged and repeated stress a breakdown of the respiratory and circulatory mechanisms, involving also the nervous system, is to be anticipated, unless appropriate measures are taken to mitigate the ill effects. This has been found to be the case.

The effects of flying at great altitudes were observed as the result of the high flying which became necessary during the World War. In the earlier stages of the war such flying was the exception rather than the rule. Owing to the increasing altitudes reached by aeroplanes, however, it became eventually quite an ordinary event for high-flying aeroplanes to maintain an altitude of from 20,000 to 22,000 ft. for several hours. When this first took place it was found that after a time the pilots and observers began to suffer from the effects of prolonged exposure to such altitudes. In the air the chief among these effects were breathlessness, muscular weakness and diminution of judgment followed by great bodily fatigue. This, when frequently repeated, led to the signs of breakdown already given.

Another effect of high altitudes was the onset of drowsiness or sleepiness. In some cases this was excessive and pilots have stated that they have fainted at great heights and cannot remember landing, whereas they have actually been sufficiently awake to fly the machine and land it in their own aerodrome with verbal assistance from the observer.

At great altitudes there is, therefore, either a general slackening of moral and loss of offensive spirit or else a feebleness of judgment which may lead a pilot into unnecessary difficulties. The effects of high altitudes upon judgment are insidious and constitute for the aviator a subtle danger.

Some flying officers eventually complained of headaches which at times came on while in the air, but more usually after landing. Vomiting and bleeding from the nose were very rare indeed. Cases of syncope were infrequent.

As with "mountain sickness," the symptoms described above are chiefly due to oxygen want, and it was found that with the provision of oxygen apparatus on high-flying machines these symptoms were greatly alleviated.

As is well known it has been shown that the administration of oxygen (1) tends to keep an efficient slow pulse; (2) tends to keep up a good arterial pressure; (3) keeps off the onset of distressful breathing; (4) mitigates any ill effect due to excessive deep breathing; (5) increases the power for nervous concentration and muscular work.

In flying, particularly in high flying, it is important that the pilot be able to accommodate himself to the effects of diminished pressure upon the air enclosed within the middle ear and the air passages connected with the nose. Any hindrance, for example, to effective ventilation and drainage of the frontal sinuses in the brow may lead to headaches of varying duration. As regards the ear, the external orifice affords a wide passage by which alterations of air pressure are easily transmitted to the ear drum; on the other hand the Eustachian tubes, leading from the throat to the middle ear, are narrow passages which normally open only during the act of swallowing, and therefore do not so readily transmit changes of pressure. Any catarrhal condition or congestion of these tubes, therefore, tends to produce difficulty in the equalization of pressure within and without the tympanic cavity. Generally speaking, during an ascent the ears are

unconsciously "cleared" by swallowing, which under ordinary circumstances is sufficient to open the Eustachian tubes and equalize the pressure on both sides of the ear drum. Occasionally a very graduated self-inflation, just sufficient to open the tubes, may be required to dispel a sensation of fullness in the ears. If, however, owing to very marked obstruction of the Eustachian tubes, no equalization of pressure has taken place, then at 20,000 ft. the pressure in the external auditory meatus is approximately 380 mm., while in the middle ear it is still 760 mm. (ground level), a difference of 380 mm. tending to push the drum outwards. If, on the other hand, during the relatively slow ascent to this height equalization of pressure is made, but, owing to Eustachian obstruction, little or no equalization is made during a rapid descent, then on reaching ground level there is through the external ear a pressure of 760 mm. but only about 380 mm. in the middle ear, a pressure which forces the drum painfully inwards. Such an "invagination" of the drum is sometimes found immediately after landing in pilots who complain of deafness, discomfort or pain in the ears, headaches, dizziness, nausea and, in certain cases, vomiting and fainting in the air. In less severe cases, inspection of the ear drums often shows marked distension of the blood vessels. On enquiry it is usually ascertained that the symptoms complained of have come on during descent or immediately after landing, and are in many cases attributable to difficulty in equalizing the pressure within and without the tympanic cavity. It has been found also that one-sided obstruction of the Eustachian tubes may cause vertigo and incoördination in the air. The importance to the aviator, therefore, of adequate ventilation and drainage of the middle ear through the Eustachian tubes under rapidly varying degrees of atmospheric pressure is manifest. Broadly speaking, any condition of the nose or throat which causes or is likely to cause post-nasal or pharyngeal catarrh is a potential factor in the causation of Eustachian obstruction. Abnormal conditions of the nose, throat and ears which are apparently of trifling importance on the ground tend to become considerably aggravated in the air. Free nasal respiration and a healthy condition of the upper respiratory tract are necessary in the aviator.

From what has been written it will be seen that the medical measures to be taken as regards flying consist in (a) the careful selection of flying personnel; (b) the effective care of those selected.

In the main the case for careful selection has been presented. The great necessity of nervous stability, efficient respiration and circulation has been shown. Attention has also been directed to the important part played by vision, as well as to the necessity of a healthy state of the ears and upper air passages.

A word may be added here as to the importance of vestibular stability. As already mentioned, a man cannot fly level in a fog. In certain countries, particularly in the United States, great importance was at first attached to the supposed "motion-sensing functions" of the vestibular apparatus. On them the success or failure of candidates for flying was believed largely to depend. The sensitivity of the vestibular apparatus was tested by means of "rotation tests." As the result of special investigation, so great an importance is not assigned to these tests in England. Generally speaking, rotation tests therefore are only employed when a candidate gives a history of giddiness, train or swing sickness, suggestive of undue sensitivity of the vestibular apparatus.

At first no special medical examination was made for flying, but early in the World War medical officers with squadrons collected considerable evidence which proved that a special examination was necessary. They were constantly seeing pilots who were breaking down or had actually broken down from causes which should have precluded their admittance to the flying services.

In addition to visual defects, *otitis media*, and conditions resulting in Eustachian obstruction, numerous instances of gross nervous instability were observed amongst unfit flying officers, who could never have been accepted for the service had details of their past histories been elicited at a medical examina-

tion. In the selection of flying personnel the importance of the past history of the candidate cannot be overestimated.

Nowadays candidates in England, both for military and civil aviation, are submitted to:—

I. A surgical examination, comprising, in addition to measurement of height and weight, observations as to any existing surgical abnormality, congenital or the result of injury or disease, which is likely to impair the efficiency of the individual.

II. A medical examination, including enquiries as to previous occupation, family and personal medical history, an investigation of the various systems, including special tests for flying efficiency.

III. An examination of the eyes from the point of view of normal acuity of vision and also of good ocular muscle balance. Normal colour vision is also demanded.

IV. An examination of the ears, nose, throat and buccal cavity, including tests of hearing, the patency of Eustachian tubes, and, when deemed necessary, the sensitivity of the labyrinthine apparatus.

V. An assessment in which, after such further examination as appears necessary, a decision is formed as to the candidate's fitness for flying.

The special tests employed in the assessment of efficiency are as follow:—

For respiratory efficiency:—

1. Measurement of the respiratory capacity by means of a spirometer.

2. The length of time during which the breath can be held after full expiration and full inspiration.

3. Measurement of the expiratory force—that is, the height to which the subject can force a column of mercury with the cheeks and lips held.

For circulatory efficiency:—

4. The pulse rate sitting, standing and after regulated exercise (lifting the body weight on and off a chair five times in fifteen seconds).

5. Measurement of the systolic and diastolic arterial pressures.

For nervous stability and neuromuscular coördination:—

6. Observation of knee jerks and other reflexes.

7. Observation of presence or absence of tremor of eyelids, tongue and fingers.

8. The ability of the subject to stand steadily on one leg for 15 seconds with the eyes closed and hands to side.

9. The ability of the subject to raise from table to shoulder level and replace again an unstable rod placed on a piece of board.

Tests for endurance and resolution (testing respiratory and circulatory efficiency and nervous stability):—

10. After full expiration and full inspiration, the length of time during which the subject can support with the breath held, a column of mercury at 40 mm., the rate of the pulse being counted meanwhile.

The standards for these tests, which are used as adjuncts to the clinical examination, have been set by the examination of efficient pilots who have rendered satisfactory aerial service. Results have also been obtained from larger numbers of pilots who have partially or wholly broken down.

The duty of forming a final decision as to the candidate's fitness for air work rests with the assessor, a medical officer of wide experience. His decision is based upon a review of all the facts and observations recorded by the examiners, checked and supplemented by an examination on his part of such points as appear doubtful.

Apart from the elimination of cases which fail to satisfy the requirements in respect of the special senses of sight and hearing or show signs of organic disease of a gross or potentially disabling nature, the assessor's main duty is to ensure that the accepted candidate is possessed of a mental aptitude and a degree of stamina and nervous stability adequate to withstand the stress of training and of subsequent service in the air.

In forming an opinion on these points, no attempt is made to determine the temperamental suitability of candidates by elaborate psychological methods. In most cases the assessor is able to gain an insight into the candidate's general "mental make-up" by interrogation as to his motives for wishing to fly, by ascertaining his keenness for sports and games and by obtaining details as to his service, if any, in the war. The evidence as to the soundness of the stock from which the candidate

comes, the illnesses from which he has suffered, the stresses to which he has been exposed and the manner in which they have been borne, are of prognostic importance. Reliable impressions are also formed in many cases in the course of ordinary clinical examination, additional aid in arriving at a decision being afforded by the candidate's method of performing the various tests of the cardiovascular, respiratory and neuromuscular systems. When deemed necessary the psychomotor reflexes may be measured.

After admission much devolves upon the medical officer in the way of careful supervision. As in other branches of the medical profession, the success of the medical officer in preventing breakdown from flying strain depends largely upon his mental aptitude for, and his attitude towards, his work. To the medical officer the flying officers under his care are so many human engines, and it is his duty to keep them as far as possible in fit condition, properly attuned, and to overhaul them periodically so that he can say whether they are wearing well or showing signs of strain, and, if the latter, to take necessary measures to prevent any disaster.

The medical officer should live as much as possible among the officers under his charge; by this means he acquires an intimate knowledge of their characters, which he may use sympathetically and confidentially as occasion arises. Each flying officer is, so to speak, an individual unit, and requires his own special study. Much of the medical officer's best work, therefore, is done in the mess, on the aerodrome, or at games. For example, indications of "fatigue" may be observed when a pilot, usually efficient, begins to land badly, or returns from a relatively simple flight unduly exhausted; when a moderate drinker begins to take more than is good for him; or when a sociable pilot prefers always to sit alone quietly reading in the corner. A little tact and sympathy on the part of the medical officer under such conditions may make all the difference between recovery and breakdown.

It should always be borne in mind that a certain number of pilots are liable to develop an "anxiety" in regard to their occupation, especially as the result of the stress of early training or of prolonged service in the air. The first symptoms of such anxiety are best detected by a medical officer knowing each of his pilots personally. Thus during the training stage much information can be gleaned by a quiet chat with an officer or cadet in regard to his sensations while in the air, either when receiving dual instruction or when learning to acquire proficiency at aerial acrobatics. The stress of the first solo flight must always be borne in mind. It must be remembered also that a young officer is generally averse to showing any sign of what he fears may be deemed cowardice. Yet, during the stages of training, he is probably constantly repressing a tendency to be afraid, which is only natural. With such an individual a frank discussion of his fear with the medical officer will frequently improve his condition. It is a great help, from the pilot's point of view, to be assured by a medical officer in whom he has confidence that he is in good condition, or that he is not a coward, and that many other pilots who have eventually "made good" have been through the same stages of "wind-up." In gleaming information as to the "anxiety state," note should be made of such points as change of habits, restlessness, irritability, tendency to jump at any sudden noise, or inability to concentrate. Enquiry should be made as to sleep and the nature of dreams or nightmares. The "anxious" pilot is particularly liable to insomnia, anxiety dreams and nightmares. In his dream or nightmare he is nearly always performing something connected with his daily duties, and falling in its performance. The importance of good refreshing sleep in a flying officer cannot be too strongly emphasized.

Periodic medical examination will also give indication of the onset of flying strain or fatigue, and if found, appropriate steps can be taken to prevent or mitigate it.

Attention has already been drawn to the great importance of the use of oxygen for flights at high altitudes or of long duration, as well as to the great value of sports and games in promoting flying skill and bodily endurance in pilots. Periodic advice

by medical officers in respect of the ill effects of too much smoking or alcohol also play a part in the effective care of flying personnel. Advice may also be given in regard to the efficient protection of the body.

The intensity of the cold varies with the season of the year and with the height attained; it is accentuated also by the speed of the machine through the air. To prevent loss of body heat while flying, special suits have been designed, the cardinal principle of which is to keep the body surrounded by layers of warm air. In most cases this warmth is derived from the body, but the warming of clothing by electric means has also been tried. For warmth purposes, great thickness of clothing is by no means necessary. Underclothing should be loose-fitting; two thin garments of closely-woven texture, either of wool or silk, are better than one thick one. Research has shown that the warmth-giving power of clothing lies in the fineness of the mesh rather than in its thickness. Care should be taken to avoid orifices through which the outside air can permeate. Tight clothing should be avoided, particularly clothing which tends to hamper the movements of the chest and abdomen or to restrict the circulation of the limbs. Frequently, however, it is necessary to employ considerable additional protection for the legs, especially for the feet, and for this reason care should be taken to provide suitable additional protection in the form of warm, loose-fitting stockings.

For the protection of the face, a fairly close-fitting head and face piece of non-absorbent and non-porous material may be made, the inner surface of which will not absorb the oil or grease with which it is advisable to anoint the face when severe cold has to be endured. Over such, a woollen balaclava may be worn, and then a flying cap of close-fitting design.

For the protection of the hands a series of suitable gloves may be employed; for instance, thin silk gloves covered by woollen gloves, the whole enclosed in a leather gauntlet, which can be easily removed for delicate work. Gauntlets provided with a specially adaptable finger muff are to be recommended. In certain cases electrically heated gloves have also been employed.

For the protection of the eyes well-fitting fur-lined triplex goggles should be employed. The fogging of goggles may be prevented by certain preparations which are on the market. Some pilots prefer to employ tinted goggles; this is especially necessary for flying in the tropics, otherwise the effects of glare are soon felt.

In regard to diet, gas-producing foods are best avoided, since altitude causes expansion of the gases of the intestines, but in practice there is little need for the healthy person to worry about the constitution of his diet. It is important, however, that no flying should, under any circumstances, take place upon an empty stomach.

Before long flights it is advisable not to partake of food of too fluid a nature or of too much liquid. By this means the desire to urinate in the air during a flight is avoided. On very long flights, a supply of liquid food, such as sweetened cocoa or malted milk, may be carried in special thermos flasks. In addition compressed food in the form of tablets or chocolate may be provided.

Finally if "flying strain" supervenes the treatment necessary is such as would be applied to the condition of "fatigue" arising in any other occupation. According to his chief symptoms the patient may pass for treatment of an anxiety neurosis to the neurologist or for the treatment of respiratory and circulatory symptoms to the general physician. But it is always to be remembered that the keynote of the effective care of flying personnel lies in prevention rather than cure. (M. FL.)

**AFGHANISTAN** (see 1. 306).—The visit of the Amir Habibulla Khan to India at the beginning of 1907 was destined to exercise a powerful and beneficial influence on the attitude of the Afghan ruler during the rest of his reign throughout periods of unusual crisis and strain. It gave him the opportunity of making acquaintance with British officials and Anglo-Indian society, and the result was a new development of friendship and mutual

confidence. The effect in Afghanistan of the Anglo-Russian Convention signed on Aug. 31 of the same year was not of a similarly happy nature. Articles III. and IV. of the Convention, which provided respectively for the establishment of direct relations between Russian and Afghan frontier authorities and the maintenance of equality of commercial opportunity for British (and British-Indian) and Russian trade and traders, were interpreted by the Afghans as an attempt to interfere with the economic autonomy and political independence of their country. Article V. laid down that the Convention would only come into force on the notification of the Amir's consent to its terms. This consent, though repeatedly pressed for, was never given by the Amir.

From 1908 to 1914 the history of Afghanistan remained peaceful and uneventful, and was chiefly remarkable for the gradual introduction into the country of measures of civil, economic and military reform.

Influenced by what he had observed in India, steps were taken by the Amir to open schools, increase facilities for the education of the upper classes, establish factories, introduce telegraphs and telephones and to provide medical relief. The provision of improved military education and reforms in the training of the army were likewise taken in hand. For the above purposes a number of foreigners were imported into Afghanistan, and of these the majority were Turks. It was, however, in the direction of public works that the Amir chiefly directed his energies. Great efforts were made, largely by means of forced labour, to improve the internal communications. Metalled roads were constructed between the principal local centres, and good roads, realigned and fit for motor traffic, were constructed from Kabul to Dikka and from Kabul to Kandahar. Important irrigation canals were also constructed, notably the Nahr-i-Siraj from the Helmand river near Kala Bist; from the Kabul river near Daronta; and the Panjeh Argandab canal from the Argandab river near Kandahar.

The outbreak of war in 1911 between Italy and Turkey created, as might be expected, a general wave of sympathy among the Afghans for their co-religionists in Turkey, and considerable sums of money were subscribed by the general public to Turkish funds.

When in Aug. 1914 war was declared between England and Germany the Amir was immediately informed by the Government of India and asked to maintain the strict neutrality of Afghanistan, and to this he gave a solemn assurance on the understanding that the safety and independence of Afghanistan were not interfered with.

On the entry of Turkey in Nov. 1914 into the war on the side of Germany, the Government of India, in communicating the event to the Amir, laid stress on the non-religious nature of the struggle, and brought to his knowledge the terms of a proclamation issued by the British Government pledging immunity from attack of the Holy Places of Arabia. The intervention of Turkey under German influence could not fail to place the Amir in a very difficult position. Public feeling in Afghanistan was profoundly stirred by this event, and the trend of popular feeling under other conditions of rulership might have led to far different results had not the Amir Habibulla Khan, faithful to his pledge, maintained throughout the long years of the war an attitude of strict and correct neutrality and enforced it upon his country, notwithstanding many temptations and inducements both from within and without his country. Within Afghanistan the voice of religious bigotry and fanaticism was loudly raised on the side of Turkey, while the opportunists proclaimed against the folly of not taking advantage of so favourable a moment for successful aggression.

More seductive still were temptations from outside. Chief among them were the persuasions of an important mission which the German Government despatched towards Afghanistan in the spring of 1915. The party were selected to comprise such elements as would be likely to appeal to Afghan sentiment—Indian seditiousists were, both Mohammedan and Hindu, together with German and Turkish officers. The mission bore letters from the German chancellor, and were charged to make important revelations regarding possible future relations between Afghanistan, Germany, Austria and Turkey. The mission reached Kabul through Persia towards the end of 1915, and were dismissed in May 1916, without effecting their purpose.

The continuous and unwavering loyalty of Amir Habibulla Khan to his pledges to the British Government throughout the changing vicissitudes of the World War forms one of the most remarkable incidents of that eventful period. He not only maintained throughout the strictest neutrality of his country but successfully used his influence to preserve peace among the unruly tribes on the frontier, thereby diminishing demands on the depleted garrison of India.

With the Armistice of Nov. 1918 the World War came to an end, but Afghanistan was not long to enjoy the benefit of peace.

At 3 A.M. on Feb. 20 1909 Amir Habibulla Khan was shot in his bed in his tent at Kala Gosh while touring in the district of Lamaghan. His brother Nasrulla Khan, then at Jalalabad, at once proclaimed himself Amir of Afghanistan in his stead. Prince Amanulla Khan, the third son of the late Amir by his principal wife, the Ulya Hazrat, who was then residing at Kabul as governor, was simultaneously proclaimed Amir by the people of all classes at the capital. His uncle Nasrulla Khan at once abdicated in his favour, and his elder brothers, Inayatulla Khan and Hayatulla Khan, and other members of the royal family, acknowledged his succession to the throne. The facts relating to the murder of Habibulla Khan have never been made known. Nasrulla Khan was charged with complicity and sentenced to imprisonment for life. In a letter dated March-3 1919 to the Government of India, Amanulla Khan announced his accession with protestations of friendship to the British Government. Mischievous and unfriendly influences however, so long kept in check by the wise, restraining hand of Amir Habibulla Khan, soon began to display themselves. In April the new Amir proclaimed the independence external as well as internal of Afghanistan. In the same month a mission under Gen. Wali Mohammed Khan was despatched to Moscow to institute relations with the new Soviet Government. Grossly exaggerated and unfounded reports of rebellions in India and of British tyranny in India and Mesopotamia were spread broadcast by official agency throughout the country and frontier tribes, and exhortation was addressed to all to be prepared for a call to arms. This was quickly followed by the proclamation of a *jihad* (holy war) and the cupidity of the credulous Afghan people and frontier tribes was aroused by promise of an easy conquest of India.

Early in May information accumulated to the effect that the plan of operations decided upon by the Afghan Government was to attack simultaneously on three fronts under separate generals through Dikka, Khoist and Baluchistan, by hordes of Ghazis (religious fanatics) supported by regular troops. Prompt measures were accordingly taken to reinforce British forces on the Indian frontier.

The arrival of Afghan troops at the western end of the Khyber was reported on May 3, and active hostilities opened on May 8 by the occupation by Afghan regular troops of the heights commanding Landi Kotal. From there they were immediately expelled, and the British force in the Khyber, advancing into Afghanistan, occupied Dikka May 13. This prompt measure, and the menace it involved to the safety of Jalalabad, had an immediate and discouraging effect on the Afghan plan of operations, and was shortly followed on May 28 by the capture of the Afghan fortress of Spin Baldak which threatened the security of the southern capital of Kandahar.

In a letter dated May 28 the Amir addressed the Viceroy of India, definitely asking for peace and suggesting a cessation of hostilities. He was informed in a reply dated June 2 that an armistice would be granted on certain terms, which included the withdrawal of all Afghan troops from within 20 m. of the British front and the exercise of the Amir's influence in restraining the frontier tribes from further hostilities. These terms with but slight modifications were accepted by the Amir in a letter of June 11, in which he agreed to send delegates to India to discuss terms of peace and the reestablishment of former friendly relations between the Afghan and British Governments. These delegates duly arrived at Rawalpindi on the date appointed, July 25, and peace was formally signed on Aug. 8.

The preceding narrative of the war has only referred to the brief operations in which British troops were engaged with forces of the Afghan regular army. Open hostilities by the latter against British forces may be said to have ceased on June 3. This, however, represents but a small portion of the actual fighting which took place between the outbreak of war at the beginning of May 1919 and the signing of peace in Aug. 1919. Throughout the whole of that period, continuous conflict prevailed, now at one point, now at another, along the whole stretch of the north-west frontier of India from Chitral to Chaman. The rising of the frontier tribes failed, as such risings always have failed in the past, to be simultaneous, and the ardour of many tribes received a wholesome check from the news of British successes and the capture of Dikka in the north and of Spin Baldak in the south at the outset of the war. Nevertheless the call to *jihad* and the cupidity aroused by specious promises of plunder, together with the encouragement and material support given by bodies small and large of Afghan regular troops interspersed along the frontier, succeeded in causing many of the great frontier tribes, Mohmand, Afridi, Wazir, Mahaud and Shiranni, to throw themselves at one time and another against whatever appeared to be weak points



in the British line of defence or occupation. Instances of loyalty to the British Raj were, however, numerous. In the north the tribal levies of Chitral victoriously resisted continuous Afghan aggression, while in the Kurram and Swat valleys, and farther south in Baluchistan, all but a few tribes remained firm. Military operations throughout this period of struggle were of an exceptionally severe and arduous nature, owing not only to the great heat that prevails at that season of the year in the frontier tracts, but to the severe outbreak of cholera which occurred along the whole front and caused serious losses among the troops engaged. The armistice of June 11, which terminated hostilities between the regular troops on either side, had but little effect on the guerrilla warfare raging along the frontier, and this continued, notably in Waziristan, until even after the signing of peace on Aug. 8.

The treaty of peace laid down that the British Government, in view of the circumstances which led to the war, would on their part withdraw the privilege, hitherto enjoyed by former Amirs, of importing arms, ammunition and warlike munitions through India; would confiscate the arrears of the late Amir's subsidy and grant no subsidy to the present Amir, but would be prepared, if the Afghan Government gave proof, by good conduct in the meantime, of a genuine desire for friendship, to receive another Afghan mission after a period of six months, to discuss the settlement of matters of mutual interest and the reestablishment of friendly relations. The Afghan Government on their part agreed to adhere to the Indo-Afghan frontier accepted by the late Amir, and also to assent to the early demarcation of the hitherto undemarcated portion of the line to the west of the Khyber; British troops were to remain in their present positions until this demarcation be effected.

Demarcation was satisfactorily completed and British troops accordingly evacuated Dacca on Sept. 13. The Afghan fort of Spin Baldak had been previously evacuated on Aug. 14.

It will be noticed that the treaty of peace marks an important departure from previous practice in that no mention is made in it of the dependence of Afghanistan on the British Government in external affairs, in regard to which previous Amirs, 'Abdurrahman and Habibulla Khan, had bound themselves to follow the advice of that Government. In a letter handed by the Foreign Secretary to the Government of India to the Afghan delegate immediately after the signature of the treaty it was expressly stated that that treaty left Afghanistan free and independent in its affairs both internal and external.

Reference has been made to the despatch in April 1919 of an Afghan mission to the Soviet Government at Moscow. This mission, under Wali Mohammed Khan, reached Moscow on Oct., and were well received. Meanwhile, in Sept. 1919 the Soviet Government of Turkestan despatched a mission to Kabul under M. Bravin, a former member of the Russian imperial consular service. In Nov. 1919 the Soviet Government of Moscow, desiring to establish a more direct control by themselves of foreign relations in Asia, also sent a mission under M. Suritz, which reached Kabul in Jan. 1920. M. Suritz, superseding M. Bravin, at once commenced negotiations with the Afghan Government, and in the course of the summer despatched to Moscow the draft of a treaty which, it is understood, provided for the grant of a subsidy to the Amir, the supply of material assistance and expert instructors and the establishment of Russian consulates in both eastern and northern Afghanistan.

In the meantime, after a lengthy correspondence between the Indian and Afghan Governments, it was decided that an Afghan mission, as arranged in the treaty of peace of Aug. 8, 1919, should be sent to India. They arrived at Mussoorie on April 14, 1920, under the charge of Sardar Mahmud Beg Tarsi, the Afghan Foreign Minister, and were met by a British delegation under Sir Henry Dobbs, the Foreign Secretary to the Government of India. The conference lasted until July 24, when the Afghan delegation were presented with a statement of the general lines on which the British Government were prepared to discuss a formal treaty. Throughout this period the attitude of the Afghan Government in respect to questions under discussion was swayed backwards and forwards by outside concurrent events, notably by the steady strengthening of the Turkish Nationalist position in Anatolia, the change of Government and the growth of Bolshevist influence in Persia, the outbreak of revolt in Mesopotamia, and by the increase of political agitation in India. Near home also, a renewed outbreak of hostilities, fostered and assisted by Afghan agency, on the Indo-Afghan frontier in Waziristan, led to lengthy military operations, and raised hopes in the mind of the Afghan Government that the British Government would not be indisposed to consider the question of changes in favour of Afghanistan of the Indo-Afghan boundary.

On Oct. 16, 1920 the Soviet Government of Moscow signed a treaty with Afghanistan, subject to ratification by the Amir. The exact terms of this treaty were still unknown in Nov. 1921, but were understood to be on the lines of the draft prepared in April by the Suritz mission. In Nov. 1920 the Turkish general, Jemal Pasha, arrived in Kabul on a special politico-military mission; and in 1921 a British mission under Sir Henry Dobbs was also sent to Kabul.

(A. H. McM.)

AFRICA (see 1,320).—Territorial changes in Africa between 1910 and 1921 resulted in a repartition of large areas of the con-

tinents; knowledge of its physical features largely increased and means of communication developed. Social and economic factors, affecting all races, acquired new values. The present article surveys these matters broadly under the headings: (1) Exploration; (2) Communications; (3) History.

1. *Exploration*.—The largest unknown area of Africa in 1910 was in the Sahara, of which the central part only had been adequately explored. French officers had begun as early as 1904 to make itineraries in the Western Sahara. These were continued by Gen. Laperrine, Capt. Martin, Capt. Mougin, Capt. Augiéras and others. A long-cherished design was realized on Christmas-day when, in mid desert, a column under Capt. Augiéras coming from Algeria effected a junction with a column under Maj. Lauzanne which had started from Atar in Mauretania. The result of these 18 years of work was that by 1921 a roughly accurate knowledge of the region had been obtained. The Western Sahara consists of a central dome (the Ergab) of moderate elevation, almost surrounded by great tracts of the sand dunes. The "central dome," though uninhabited, contains habitable regions, and is regularly traversed by organised bands of brigands who set out from Southern Morocco to pillage the tribes of Mauretania and the middle Niger. Abundant traces of ancient human occupation in the Western Sahara have been discovered; except that they are pre-Islamic it has been impossible even approximately to fix their age. The great depression known as the Juf, to the N.E. of Timbuktu, remained unexplored up to 1922.

But it was in the region bordering the southern end of the Eastern Sahara, and in the Libyan desert itself that the greatest gaps existed in the map of Africa in 1910. Several of these gaps were filled, and the chief remaining problems in the hydrography and orography of Africa were solved by Lieut.-Col. Jean Tilho and his colleagues in an expedition extending from 1912-7. The main object of Col. Tilho was to ascertain whether the basin of the Chad was closed or belonged to that of the Nile, and that thus there was, as tradition asserted, a water connexion between the Niger and the Nile (see 19,676). In a previous expedition (1908-9) Tilho had found that the Soro (the Bahr-el-Ghazal channel running E. of the Chad) was of the same level as the lake for a very considerable distance. The 1912-7 expedition discovered that a mountainous barrier encircled the basin of the Chad from N. to S.E., that, it had no fluvial connexion with the Nile basin. But N.E. of the lake is a low-lying zone of which the lowest point is 520 ft. below the level of Chad. This point is in the recently dried-up bed of the lake of Kirri and is some 250 m. from Lake Chad. Thus Chad was proved to be but the remains of a vast lake comparable in size to the Caspian. The Tilho expedition also explored the Tibesti and Ennedi (Endi) mountains, and discovered another massif, that of Erdi, connecting Tibesti and Ennedi. It also learned of the existence in the Libyan desert of another mountain mass, the Jebel el Aumiat (about 150 m. S.E. of Kufra), with heights probably exceeding 4,000 feet. Hypsometric determinations enabled the expedition to ascertain the heights of the chief summits of the mountain chains between Chad and the Nile. The highest points are Emi Kussi, 11,200 ft. (an extinct volcano), and Tasside, 10,700 ft., in Tibesti, and (the) Jebel Marra, 9,800 ft., in Darfur. The exact longitude of many places was determined by wireless time signals from the Eiffel Tower, and a chain of astronomical positions completed the connexion of the maps of the Niger, Chad and Nile. Some 7,000 m. of surveys were made by the expedition. Particular interest centred in the exploration of Tibesti, which had been seen by one European only (Nachtigal in 1866) until it was reached by Camd. Lofler in Dec. 1913. It had been thought that Tibesti might prove a well-watered fertile region, but though it contains pasture lands, palm-groves, and flowing rivers it is mainly arid—a magnificent mountain-mass with deep gorges and serrated ridges, falling eastward in giant steps; westward overlooking a boundless plain.

Of the Libyan desert Mr. W. J. Harding King collected much information from native sources and himself investigated its north-western fringe. Early in Jan. 1921 Mrs. Rosa Forbes, a young Englishwoman, reached Kufra from Cyrenaica, and the following month travelled to Jarabub by a new route. Except by a French prisoner of the Senusites who was interned there in 1916, Kufra had only once before been visited by Europeans—by Rohlf and Anton Stecker in 1879—and Mrs. Forbes showed that the extent of the oases was less than supposed and their position incorrectly mapped. Evidence of increasing desiccation of the desert was obtained—one stretch of 350 m. traversed was without a well or water of any sort.

In the upper Nile basin Capt. H. D. Pearson, director of surveys in the Sudan, explored (1911-2) in part the head streams of the Pilbar, the main western branch of the Sobat. Captain H. A. Darter investigated other parts of the Sobat system, and Capt. R. H. Leake in 1912 explored the adjacent southern region—that between the Bahr-el-Jebel (Mountain Nile) and Lake Rudolf. The chief feature of

These figures are subject to rectification on the full working-out of the data obtained by the expedition.

forming the Nile-Rudolf watershed, which drops abruptly into the Turkana plain on the Rudolf side, but slopes gradually westwards to the Nile. It has heights of 70,000 feet. The expeditions named nearly completed the exploration of the region between the Nile and Abyssinia. In 1915-6 Maj. Cuthbert Christy made a ten months' journey along the Congo-Nile divide, where it forms the frontier of the Anglo-Egyptian Sudan. The divide proved to be "a continuous and more or less level strip of bush-covered country (mostly of ironstone formation), sometimes as much as two miles in width but often only a few yards." In Maj. Christy's opinion the divide was perfectly suitable for the building of a railway, a roundabout link in the Cape-to-Cairo scheme.

Mr. I. N. Dracopoli in 1912-3 explored part of southern Jubaland. He reached the Lorian Swamp—which receives the waters of the Uaso Nyiro—and solved the problem of its outflow. He found that the Lake Dera issues from Lorian in a well-defined bed and, though usually dry in its lower course, is, through Lake Wama, a tributary of the Juba river. Mr. (afterwards Sir) G. F. Archer completed in April 1912, after over two years' work, surveys connecting the triangulation of British East Africa with Maj. Gwynn's Abyssinian boundary survey. Captain R. E. Salkeld in 1913-4 further explored Jubaland, drawing attention to the over-running of that region by the Somalis—the most recent instance of the migration of African races.

In east central Africa a survey by Capt. E. M. Jack, in 1911, of the region N.E. of Lake Kivu and W. of Victoria Nyanza resulted in making known a healthy highland region and added to the knowledge of the Mfumbiro range of active volcanoes. Karissimbi was found to be 14,780 ft. high. In Dec. 1912 Sir A. Sharpe and Mr. M. Elphinstone witnessed the formation of a new volcano, named Katarusi, which, following an earthquake, rose out of an old grass-covered lava-field, sending into the N.E. corner of Kivu a river of lava which filled up a "large bay."

The first survey along its whole length of the Congo-Zambezi watershed was made in 1911-4 by Anglo-Belgian and Anglo-Portuguese boundary commissions, the principal commissioners being Capt. Evered (killed by a lion), Maj. E. A. Steel and Maj. Reginald Walker (British), Maj. Bogrand and Capt. Weber (Belgian) and Capt. C. V. Cogo Coutinho and V. da Rocha (Portuguese). As in the Congo-Nile watershed, it was found that many rivers ran for considerable distances parallel to the divide, which is largely bush-covered. Major Walker discovered that the Luapula (the main eastern headstream of the Congo) did not, as was believed, issue from Lake Bangweulu, but was a continuation of the Chambezi, which passes through the great swamp S. of Bangweulu.

Another boundary commission, under Capt. W. V. Nugent and Oberleutnant Detzner, in 1912-3 demarcated the Nigeria-Cameroon frontier between Yola and the Cross river. The frontier followed roughly the edge of the highlands overlooking the fertile plains of the Benue and was an instance where the straight lines drawn on the map by diplomatists to mark international boundaries worked out fairly well in practice.

During the World War exigencies of campaigning led to many additions to exact knowledge of the topography of tropical Africa, partly through the use of aircraft for survey purposes. Thus very useful maps, showing routes unsuspected on the ground, were made of Portuguese Nyasaland by airmen. In 1920 Dr. P. Chalmers Mitchell, who passed over the whole length of the Nile basin in an aeroplane, proved the value to geology of air reconnaissance by the discovery in the Bayuda desert N. of Khartoum, of the volcanic character of a range of hills. Between Old Merowe and Atbara the aeroplane crossed "a high and irregular range of hills running east and west. In the middle of them was a great plain looking like toffee poured out on a plate. From this a number of craters rose, two large, one with a sandy interior with thorn bushes, the other with a second peak and crater inside the outer rim." From pieces of tufa recently obtained from the Nile Valley, N. of Khartoum, the existence of some unknown Tertiary volcanic field in that region had been suspected. Exploration on the ground remained to be undertaken, but Dr. Chalmers Mitchell's observations would appear to be the first important geological discovery made from the air.

2. *Communications*.—The first railway and steamer route across Africa was completed by the opening in March 1915 of a railway from Kabalo on the Luabala (Upper Congo) to Alberville on the west shores of Lake Tanganyika. The year before (1914) the German railway from Dar es Salaam had reached Kigoma, on the east shores of Tanganyika. A part of this Atlantic-Indian Ocean route is by the Congo, the non-navigable stretches of the river being bridged by railway. An all-rail east-west route across South Africa had also been effected in 1915, when a line was built from Prieska to Kalkfontein connecting the S.A. system with that of German South-West Africa. By this means Walvisch Bay and Delagoa Bay were linked by railway. A second east-west all-rail route across Africa will be provided by the railway from Lobito Bay to Katanga, where it will join the lines to Beira and other east-coast ports, as well as to Cape Town. In 1920 some 600 m. of rails remained to be laid on this route. The surveys had been completed in 1920 and construction began in 1921.

None of these lines was designed as a transcontinental route,

though the Dar es Salaam-Congo route was so used for passenger traffic.

With the Cape-to-Cairo scheme little progress was made in the period 1910-21. The railway from Cape Town, via Bulawayo and the Victoria Falls, which had reached the Belgian Congo frontier in 1909, was however continued N. across Katanga to Bukama on the Luabala (Upper Congo), the line being completed in May 1918—an addition of 442 m. in ten years, making a through service from the Cape, on the same gauge (3 ft. 6 in.), of 2,598 miles. In 1921 the construction of a further section of the railway to a more northerly point on the Luabala, where navigation was easier than at Bukama, was begun. But from 1918 it was possible, by utilizing the Congo and Tanganyika systems, to travel alternately by train and steamer from the Cape to Cairo, with only two breaks—together not more than 300 m.—to be covered on foot. The southern break was from Tabora (on the Tanganyika railway) to Mwanza, on Victoria Nyanza; the northern from Nimule to Rejaf, along the banks of an unnavigable stretch of the Upper Nile.

These cross-Africa routes were valueless for through goods traffic; their function was to bring the produce of Central Africa direct to the nearest seaport. Thus the Tanganyika railway made Dar es Salaam the natural port for the trade of a large portion of the eastern part of the Belgian Congo. With the main routes may be mentioned the line (built 1916-8) from Qantata on the Suez Canal, across the Sinai peninsula to Gaza, which put Africa and Asia in direct railway communication, Cairo being linked with Jerusalem, Damascus, Aleppo, etc.

With regard to trans-Saharan railways, from Algeria to the Niger countries, surveys made in 1912-3 showed that there were routes presenting no engineering difficulties. From Maala, in the Algerian Sahara, the route is by Anhet, W. of the Ahaggar (Hoggar) massif to the Niger at Tosaye (Burem), some 200 m. below Timbuktu. What was regarded as the first section of the trans-Saharan was the line from Biskra to Tuggurt, opened in 1914. From Tuggurt to Tosaye by the route indicated is 1,470 miles. A line from Blida to Jelfa, on the way to Laghwat, was also built.

French projects to connect the Middle Niger with the ports of the Guinea Coast were hindered by the World War. The scheme was for railways from Dakar (Senegal), Konakry (French Guinea), Abidjan (Ivory Coast) and Kotonou (Dahomey) to be carried inland to the French Sudan (the French Niger colony), and there united by a transverse line. Political and economic considerations induced the French to neglect the Gambia river (as being British), the natural outlet for the French Sudan—the Gambia is navigable from the ocean by vessels drawing 13 ft. up to 153 m. inland. Of the lines proposed, that from Thies (Dakar) to Kayos, on the Senegal, begun in 1907, has a length of 682 m., of which about 700 m. remained to be built in 1920. The French Guinea line from Konakry reached Kurussa (365 m.) in 1910 and Kankan, in the French Sudan, 411 m. from Konakry, in 1915. This led to much of the trade of the countries in the Niger bend going to Konakry. The Ivory Coast railway from Abidjan, traversing a dense forest region, reached Buaké (193 m.) in 1913. No progress northward had been made by 1921. The Dahomey railway had reached Savé (162 m.) in 1912. All four lines are of the French standard West-African gauge, namely one metre. Besides the railways the French built many hundreds of miles of metalled roads, on which motor services connecting with the Niger countries were established.

In British West Africa local lines and extensions, on differing gauges, were built during 1910-20; there was unity of plan such as marked the French programme in West Africa. The building of the Niger at Jebba, completed 1914, gave the chief Nigerian railway, that from Lagos to Kano (704 m. long), an uninterrupted service. In 1913 a new railway was begun from Port Harcourt, at the mouth of the Bonny river. It was completed to the Udi coal-fields (151 m.) by May 1916. From Zaria, on the Lagos-Kano railway, a branch line, built across the tinfield area to Bukuru (143 m.), was completed in Dec. 1914. Surveys were made for an extension of the Port Harcourt-Udi line northward across the Benue river and thence north-west to a point, Kaduna, on the Lagos-Kano line. The building of this extension, some 450 m. in length, was begun in 1921. Motor services are maintained in connexion with the railways, which are Government owned.

In Morocco the French, from 1912 onward, built narrow-gauge railways for military purposes. By 1920 these connected (1) Salice with Fez, and (2) Ujda, on the Algerian frontier, with Taza, while the section Fez-Taza was under construction. From Rabat via Casablanca another line was built to Marrakesh. The river-dividing Salice and Rabat was not bridged, but a ferry service was instituted. In 1918 the French Government decided to reconstruct the lines on the normal gauge. Up to 1921 no progress had been made on the Tangier-Fez railway. In North-East Africa the decade 1910-20 saw the completion of the railway from Jibuti to Addis Abbaba, the capital of Abyssinia.

The greatest mileage of railways built in the period under consideration was in South Africa (*see SOUTH AFRICA*). A line from Beira to the Zambezi (in construction 1920) gave Nyasaland direct access to the ocean. The Germans provided their South-West Africa Protectorate with an extensive system of railways. In Uganda the British built a short railway linking Jinja, on Victoria Nyanza, with



the first navigable stretch of the Nile, and during the World War a line connecting the Uganda railway with the Usambara railway in German East Africa was constructed.

The telegraphic system was greatly extended between 1910 and 1920, while from the first-named year gaps in the telegraph lines were increasingly filled by wireless telegraphy. The first wireless station in South Africa (at Durban) was opened in 1910. The Germans by the middle of 1914 had just completed powerful wireless stations in Togoland, South-West and East Africa. The French built stations in West and North Africa (Dakar, Algiers, etc.) and in 1920 had a trans-Saharan wireless service, there being two stations in the desert. Wireless stations in Egypt and the Sudan connected with Mombasa, Tabora and South Africa.

The World War gave a great impetus to aerial communications, and Cairo became the junction for services to and from Europe, Asia and the Cape. In 1919 an air route was laid out by British officers from Cairo to Cape Town, aerodromes being built at 24 different places. The distance by the air route was 5,206 m., compared with 6,823 m. by the Cape-to-Cairo land route. The first attempt to fly across Africa was made in Feb. 1920 by Dr. P. Chalmers Mitchell in an aeroplane chartered by *The Times*. At Tabora, a little over half way, the machine crashed (Feb. 27). The first to succeed in the enterprise were Col. Sir H. A. van Rynveld and Maj. Sir C. J. Brand, of the South African forces. They reached the Wynberg aerodrome, Cape Town, after many delays and having had to use three machines, on March 20 1920. Their actual flying time from Cairo to Cape Town was 72 hours, 40 minutes. At the same time (Feb.-March 1920) French airmen, Maj. Vailleman and a comrade, flew from Algiers across the Sahara to the Niger at Gao, and thence to Dakar. The first regular air service in Africa was established in 1921, with seaplanes along the Congo from Stanley Pool to Stanleyville, a distance of 1,000 miles.<sup>1</sup>

3. *History*.—A summary statement of recent territorial changes affords a guide to the course of events in Africa. In 1910 the British self-governing colonies of the Cape, Natal, Transvaal and Orange Free State were formed into the Union of South Africa, with a single government and one legislature. In 1911 a considerable area of French Equatorial Africa was transferred to the German protectorate of Cameroon, and in return Germany acknowledged a French protectorate over the greater part of Morocco, the protectorate treaty between France and Morocco being signed in April 1912. In Nov. 1912 a Franco-Spanish treaty defined the Spanish zones in Morocco. In 1912 also Italy annexed the Turkish *vilayets* of Tripoli and Benghazi (Cyrenaica), to which they gave the common name of Libya. In the same year the United States acquired financial control of Liberia, part of its hinterland having passed to France in 1910. In Dec. 1914 a British protectorate over Egypt was proclaimed. In June 1919, by the Treaty of Versailles (which came into force Jan. 10 1920), Germany renounced possession of all her overseas protectorates in favour of the principal Allied and Associated Powers. These protectorates were placed under mandates. The Union of South Africa became mandatory for German South-West Africa, which her troops had conquered in 1915. It was renamed the South-West Protectorate. Togoland was divided between France and Great Britain (it had been conquered by British and French troops in Aug. 1914). France became the mandatory for Cameroon, but a small portion was transferred to (British) Nigeria. Cameroon had been conquered by Anglo-French forces in 1915-6. Britain became mandatory for German East Africa, renamed the Tanganyika Territory. A small fragment (the Kionga triangle) of German East Africa was, however, added to Portuguese East Africa, and the greater part of the provinces of Ruanda and Urundi to the Belgian Congo. German East Africa had been conquered, as to the greater part in 1916, by British and Belgian troops. An Anglo-French convention of Sept. 1919, ratified in 1921, settled the boundary between Wadai and Darfur, which had been in dispute since 1899. In 1920-1 Italy gained additions to Tripoli and Cyrenaica by arrangements with France and Great Britain; also the promise of an addition to Italian Somaliland at the expense of British East Africa. British East Africa, up to then a protectorate, was in 1920 annexed to the British Crown and renamed Kenya Colony.

As a result of these changes Africa was divided among the

<sup>1</sup> A mail air service from Toulouse to Casablanca had been instituted in 1920.

following Powers, territories governed under a mandate being reckoned in the possessions of the Powers named:—

	sq. m.
Great Britain . . . . .	4,364,000 <sup>2</sup>
France . . . . .	4,200,000
Portugal . . . . .	788,000
Italy . . . . .	650,000
Spain . . . . .	1,400,000 <sup>3</sup>
Belgium . . . . .	930,000
Liberia . . . . .	40,000
Abyssinia (Independent) . . . . .	350,000

These figures give a total of 12,146,200 sq. m. as the area of Africa. In the absence of definite surveys of large areas of the continent this may be regarded as a close approximation to accuracy. In 1914 the German possessions in Africa had an area of approximately 1,030,000 sq. m.; the Turkish possessions (not reckoning the legal suzerainty it possessed over Egypt) an area of some 400,000 sq. miles.

The extinction of Turkish rule in North Africa had long been foreseen and was no matter for regret. It ended a connexion which had lasted five centuries and had been almost wholly evil in its effects. German sovereignty in Africa had dated from 1884 only and had been rapidly enlarged. Endeavours further to extend it had been a prominent factor in German policy for a decade before the World War began, and closely affected very large areas of Africa. Germany desired to secure a footing on the African coast of the Mediterranean and a port on the Atlantic coast of Morocco. These desires conflicted with Italian and French ambitions, and in 1911 the issue on both points was decided against Germany. As to Morocco the Franco-German convention of Feb. 9 1909 had recognized the privileged position of France in Morocco, but not a French protectorate over that country, and the sending of the German gunboat "Panther" to Agadir in July 1911 was a protest against what Germany considered an unwarranted extension of French influence in Morocco, and an intimation that if German treaty rights in Morocco were to be renounced France must make compensation. According to Prince Bülow, Germany—in 1912—"never had any intention of taking possession of any part of Morocco . . . England and Spain, besides France, would have opposed us there" (*Imperial Germany*, 1913 ed.). Although this statement may be an after-the-event reflection the intervention of Britain on the side of France was decisive. Germany withdrew her opposition to the establishment of a French protectorate over Morocco, and accepted compensation in Central Africa. While the Franco-German negotiations were still in progress, Italy, by abruptly declaring war on Turkey and invading Cyrenaica and Tripoli, deprived Germany of her last opportunity—short of war—of gaining a footing in the Mediterranean.<sup>4</sup>

The alternative scheme to territorial acquisitions in North Africa which Germany had prepared were indicated in a note addressed to France on July 15 1911, during the Agadir crisis. Germany then proposed that France should cede the greater part of the coast and the interior of French Equatorial Africa as far as the Sanga tributary of the Congo river, and further renounce in favour of Germany her right of preemption over the Belgian Congo. These proposals Germany was compelled greatly to modify, but by the convention of Nov. 4 1911 large tracts of French territory were added to Cameroon. On the south these additions made Spanish Guinea an enclave

<sup>2</sup> Including Egypt and the Anglo-Egyptian Sudan.

<sup>3</sup> Including the Spanish zones in Morocco.

<sup>4</sup> In view of the position publicly assumed by Germany in 1898 of friendship to Moslems in general and to Turkey in particular, Germany had not sought direct rule over the Ottoman provinces in question. Turkish sovereignty was to be respected, but an Austro-Hungarian chartered company had been formed under German auspices for the exploitation of Tripoli and Cyrenaica, and under the charter Austrian (in effect German) authority would have been imposed upon those *vilayets*. Italy, however, ever since the establishment of the French protectorate over Tunisia in 1881, had "earmarked" Tripoli and Cyrenaica for herself. See the *Memoirs of Francesco Crispi* (London, 1914) and H. H. Johnston in *Geog. Jnl.* (vol. 44, pp. 200-1).

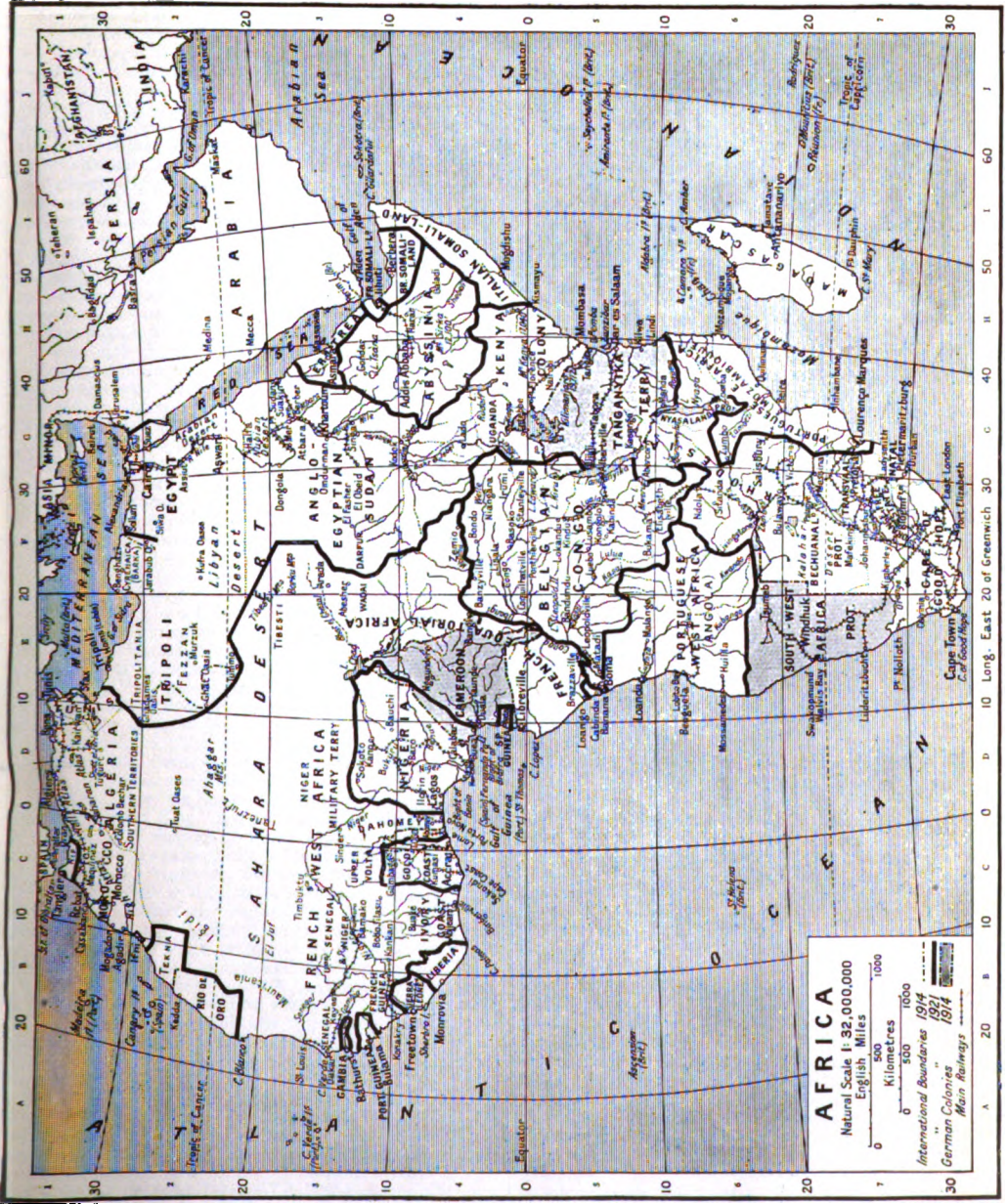



in Cameroon and gave Germany the southern shores of the Mfimi estuary. In the east the additions to Cameroon included two tongues of land which gave the protectorate direct access to the Congo river and its great northern tributary the Ubangi.

The *Mittel Afrika* scheme foreshadowed in 1911 aimed at securing Germany's supremacy, primarily economic and ultimately political, in central equatorial Africa. The aim was to reserve the Belgian Congo, Angola and Mozambique N. of the Zambezi as a German sphere and thus to link up Cameroon with the South-West and East Africa protectorates. German industries had need of the raw material tropical Africa produces, and moreover southern Angola was a good field for European settlement. British statesmen were not unfavourable to German expansion in equatorial Africa—so long as it was confined to the economic sphere. In 1898—the year of Fashoda—Mr. A. J. Balfour and Count Hatzfeldt had concluded an agreement which divided Angola and Mozambique into zones in which Britain and Germany respectively were to give financial and economic assistance to the Portuguese. This agreement was capable of various interpretations and in the following year (1899) another agreement, known as the Treaty of Windsor, renewed the ancient Anglo-Portuguese alliance, the object being to reassure Portugal that the Balfour-Hatzfeldt agreement was not in derogation of her sovereign rights in Africa. Neither the agreement with Germany nor that with Portugal was published.

After the settlement of the Morocco crisis of 1911 Germany endeavoured to come to a further understanding with Great Britain. Negotiations in regard to the Portuguese colonies in Africa were reopened by Baron Marschall, then ambassador to Britain, and were energetically taken up by Prince Lichnowsky, who came to London as ambassador in Nov. 1912. A new agreement was drawn up and its terms fixed. It affirmed the intention of the signatories to respect the sovereign rights of Portugal and went on to delimit the region in which each party was, as far as the other party was concerned, to have a free hand in respect to economic development. By Prince Lichnowsky, and by the German Foreign Office, the new agreement was looked upon as a stepping-stone to political rights in the regions concerned. By this agreement the whole of Angola up to long. 20° E. became a German sphere, together with the cocoa-producing islands of San Thomé and Principe. On the E. coast the whole of Mozambique province N. of the river Likungo also became a German sphere.<sup>1</sup> Originally Belgian Congo was, according to Lichnowsky, to have been included in the agreement, but Germany refused the offer "out of alleged respect for Belgian sensibilities."

In Aug. 1913 the agreement was ready for signature. But Sir Edward Grey, then British Foreign Minister, made it a condition of signing that the 1898 and 1899 agreements as well as the new agreement should be made public, with the obvious object of again reassuring Portugal. The German Foreign Office objected to publication, as detrimental to negotiations for concessions then proceeding with Portugal, and, as Herr von Jagow (then Foreign Secretary) said, because the German press would regard the terms of the Treaty of Windsor and the Lichnowsky agreement as contradictory. Von Jagow said that publication of the agreement would be better delayed until the Bagdad railway treaty—which was looked upon as a genuine triumph for Germany—could also be published. In July 1914 German consent to the publication of the agreement was given—but before the document could be signed the World War had begun.

During the period of these Anglo-German negotiations the French in Morocco, under Gen. Lyautey as resident general, had adopted both a bold and conciliatory policy and had won the respect of the majority of the Moors; the French also steadily developed their West African colonies and had brought under control the region between Lake Chad and the Nile basin.

<sup>1</sup> The Likungo lies about 120 m. N. of the Zambezi. The Zambezi valley and all the territory S. to and including Delagoa Bay was reserved as the British sphere. Britain already had the right of pre-emption over Delagoa Bay.

In the German colonies there was likewise considerable development, notably in the building of railways. It was a period too of material development in the British colonies and of prosperity in Egypt and the Sudan, accompanied in Egypt by manifestations in favour of self-government. In South Africa the alliance of Dutch and British, which had brought about union, had been followed by a reaction among a section of the Dutch, but the majority of the people followed the Prime Minister, General Botha, and his colleagues in their loyal adherence to the British connexion. When the World War broke out it was found that the German authorities in South-West Africa had maintained for years clandestine relations with a number of Boer leaders and that they counted, at the least, on South Africa's neutrality in the war; Germany had also established relations with elements in North Africa inimical to France and Great Britain.

But the British command of the sea rendered it impossible when hostilities began for Germany to succour her colonies. And this led to proposals for neutrality in various parts of Africa. The first such proposal was made, on instructions from Berlin, by the acting-governor of Togoland to the French and British authorities on Aug. 4 and 5, reasons of humanity and the presumed need of the white races to exhibit solidarity in face of the negroes being alleged. This proposal, purely local in scope, was not entertained (*see TOGOLAND*). Later in the month—Aug. 23—Germany made an offer of neutrality in the conventional basin of the Congo as defined in Article I. of the Act of the Berlin Conference of 1884-5. The Congo Free State, in accordance with the permission given by Article X. of the Act, had proclaimed its perpetual neutrality, and when the Free State became a Belgian colony the obligation of neutrality was retained. No other state exercising jurisdiction within the conventional basin of the Congo had, however, exercised the option given by Article X. of proclaiming its neutrality within that area, which included besides Belgian Congo about half of French Equatorial Africa, a third of Cameroon, all German East Africa, all British East Africa, all Uganda, all Nyassaland, Mozambique N. of the Zambezi, a small part of Northern Rhodesia and the northern part of Angola. Belgium had desired to preserve neutrality in the Congo. At the outbreak of the war M. Fuchs, governor-general of Belgian Congo, had been instructed to observe a strictly defensive attitude, and on Aug. 7 M. Davignon, then Belgian Foreign Minister, asked the British and French Governments if they intended to proclaim the neutrality of their territories in the conventional basin of the Congo. The bombardment of Dar es Salaam by British warships on Aug. 8 was a sufficient demonstration of the British attitude; but at first the French Government seemed disposed to entertain the proposal; so the Belgian minister in Paris informed M. Davignon on Aug. 9. But the French commander in Equatorial Africa had opened hostilities on Aug. 6, and on Aug. 17 Comte de Lalaing, Belgian minister in London, informed M. Davignon that neither Great Britain nor France could adopt his suggestion.

Hostilities in the conventional basin of the Congo had thus been proceeding for over two weeks when Germany made her neutrality offer; on the day before it was made the Germans in East Africa had committed the first act of war in the Belgian Congo by bombarding Lukuga, a port on Tanganyika. The German *démarche* was made by Herr Zimmermann, Under-Secretary in the Foreign Office, to Mr. Gerard, the American ambassador in Berlin, in a note which asked the aid of the United States to procure the neutralization of the conventional basin of the Congo. In a later note, dated Sept. 15 1914, Herr Zimmermann stated that Germany's object was "to prevent an aggravation of the war which could serve no purpose," which was not the view of Von Lettow Vorbeck, the German commander in East Africa, "while prejudicial to the community of culture of the white race." The Department of State at Washington confined itself to forwarding the German notes, without comment, to the governments concerned. Spanish aid was also sought by Germany. But France and Great Britain refused to entertain the proposals, while, the Belgian Congo



having been attacked, M. Fuchs had been given permission, on Aug. 28, to aid the French in the Cameroon campaign. The efforts of Dutch nationalists in South Africa to save German South-West Africa from invasion were equally fruitless.

In process of time the whole of Africa, except Abyssinia and the Spanish protectorates, was involved in the war (for the operations see the articles on the various countries). The conquest of the German colonies was foreseen in the negotiations which preceded Italy's entry into the war, and Article XIII. of the agreement signed in London on April 26 1915 between France, Russia, Great Britain and Italy, said:—

In the event of France and Britain increasing their colonial territories in Africa at the expense of Germany, those two Powers agree in principle that Italy may claim some equitable compensation, particularly as regards the settlement in her favour of the questions relative to the frontiers of the Italian colonies of Eritrea, Somaliland and Libya, and the neighbouring colonies belonging to France and Great Britain.

At a meeting of the Supreme Council at Versailles on May 7 1919 it was agreed to form an Inter-Allied Committee to consider the application of Article XIII., which had already been the subject of negotiations. Italian desires went beyond the readjustment of frontiers. In north-east Africa she sought a position which would give her all the seaward approaches to Abyssinia. In particular Italy desired to acquire Jibuti, the port of French Somaliland, whence a railway ran to Addis Ababa. This desire was intimated to France in the negotiations preceding the signing of the London agreement of 1915. But Jibuti was the only French port on the Suez Canal route to the East and to Madagascar, as well as the only approach to Abyssinia France possessed, and she declined to entertain proposals for its surrender. Italy, however, obtained from France a welcome rectification of the Tripoli-Tunisia frontier, besides valuable railway and commercial privileges in Tunisia. The claim to extend the hinterland of Tripoli to Lake Chad was refused. With Great Britain the negotiations were prolonged; the British Government, however, assented in 1919 in principle to a considerable readjustment of territorial claims in the Cyrenaican-Egyptian hinterland, that is in those regions of the Libyan Desert in which lay Kufra and other Senussi strongholds. The oasis of Jarabub was assigned to Italy. In East Africa the British offered an addition to Italian Somaliland by the transfer to it from Kenya Colony of the western part of the valley of the Juba—a rich cotton-growing area—together with the port of Kismayu. This offer was accepted in Sept. 1919, but the Italians desired a larger concession and this led to delays in the final settlement. The proposal to transfer Kassala from the Sudan to Eritrea was not entertained. Meanwhile the area administered by the Sudan Government had been enlarged by the conquest of the tributary sultanate of Darfur in 1915.

The distribution of the German colonies after the war has already been stated. The change of masters was readily accepted by the natives. The war itself stimulated trade in various parts of Africa and led to a development of communications (see page 67, *Communications*).

Politically the greatest movements in Africa in 1919-21 were the continuance of the separatist campaign by the Dutch Nationalist party in South Africa, and the insistent demand of the Egyptians for independence. These movements are described in the articles SOUTH AFRICA and EGYPT.

Another subject which raised large issues was the position of Indians in South and East Africa, but it was of less importance than the growth of race consciousness among the negroes. Increase of education and of Christianity, the employment of large numbers of Africans in industries, and the lessons taught by the World War, were among the factors which intensified the feeling of racial unity, and led to manifestations of a new anti-white movement—a movement different from the simple objection to interference by Europeans or Arabs previously displayed. The new movement had a consciousness of the need of self-development and progress. Not all the ferment among the negroes was however anti-white, nor was there by 1921 any clear indication what form negro nationalism would ultimately take.

**BIBLIOGRAPHY.**—*Exploration*: Jean Tilho, "The Exploration of Tiberte, Erdi, Borkou and Ennedi in 1912-1917," *Geog. Jnl.*, vol. lvi. (1920); Capt. Angières, *Le Sahara Occidental* (1919); F. R. Cana, "Problems in Exploration," *Africa*, *Geog. Jnl.*, vol. xxxviii. (1911); "The Sahara in 1915," *ibid.*, vol. xlvi. (1915); I. N. Dracopolis, *Through Jubaland to the Lorian Swamp* (1914); Sir A. Sharpe, *The Backbone of Africa* (1921); Rosita Forbes, "Across the Libyan Desert to Kufara," *Geog. Jnl.*, vol. lviii. (1921).

*Geography, Climate, etc.*: A. Knox, *The Climate of Africa* (1911); H. Hubert, *Mission Scientifique au Soudan* (1916); *Documents Scientifiques de la Mission Tilho* (1906-9), 3 vols. (1910-4); J. W. Gregory, "African Rift Valley," *Geog. Jnl.*, vol. lxi. (1920); E. H. L. Schwarz, *The Desiccation of Africa* (N. D. 1918); K. Dove, *Wirtschaftsgeographie von Afrika* (1917); R. Tjader, *The Big Game of Africa* (1911); T. Roosevelt, *African Game Trails* (1910).

*Peoples and Languages*: Oric Bates, *The Eastern Libyans* (1914); C. Meindorf, *Introduction to Study of African Languages* (1915); A. Werner, *Introductory Sketch of the Bantu Languages* (1919); Sir H. H. Johnston, *A Comparative Study of the Bantu and Semi-Bantu Languages* (1919); G. Foucart, *Introductory Questions on African Ethnology* (1919).

*History, Politics, etc.*: C. H. Stigand, *Administration in Tropical Africa* (1914); Sir H. H. Johnston, *History of Colonization of Africa by Alien Races* (new ed. 1913); *ibid.*, "Political Geog. of Africa before and after the War," *Geog. Jnl.*, vol. xlv. (1915); Evan Lewin, *The Germans and Africa* (1915); *The Disclosures from Germany* (1918) contains Prince Lichnowsky's pamphlet, with translation, Herr von Jagow's reply, and notes; L. Woolf, *Empire and Commerce in Africa* (N. D. 1920); J. H. Harris, *Dawn in Darkest Africa* (1912); D. Crawford, *Thinking Black* (1912); N. Maclean, *Africa in Transformation* (1913); F. Baltzer, *Die Kolonialbahnen, mit besonderer Berücksichtigung Afrikas* (1916); Col. Godeffroy, *Transsahariens et Transafricains* (1919).

See also the bibliographies under SOUTH AFRICA, EGYPT, etc. For current affairs consult the *Geog. Jnl.* and the *Jnl. of the African Society*, and *L'Afrique Française* (Moslem, monthly). (F. R. C.)

**AGA KHAN III.** (1877— ), Indian Moslem leader (see i. 363). During 1910-21 the Aga Khan's widening influence both on Indian and international affairs was shown in various directions. He had headed the Moslem deputation in 1906 to the Viceroy, Lord Minto, which submitted the case for encouraging abandonment of the studied aloofness of their community from Indian political life; and he was president of the All-India Moslem League thereupon formed during its first constructive years. He initiated the fund, and personally collected more than Rs. 30 lakhs, for raising the Mahomedan college at Aligarh to university status, which was effected in 1920. In the immediate pre-war years he did much to soothe Indian Moslem sentiment in respect to the Turco-Italian and two Balkan wars. He was touring amongst his followers in East Africa when the World War broke out, and immediately cabled to the *jamats* or councils of the millions of Ismailians within British territories and on their borders directing his followers to place themselves unreservedly at the disposal of the British authorities. Both in East Africa and on arrival in England he pleaded for combatant participation in the war, but Lord Kitchener reserved him for services no one else could render. When Turkey was drawn into the struggle the Aga Khan issued a stirring manifesto showing that the Allies had no overt designs on Islam, and calling upon the Moslems of the Empire to remain loyal and faithful to their temporal allegiance. His immediate followers provided a solid phalanx of whole-hearted support of Britain, which had a most steady influence in sterilizing the efforts of impatient headstrong elements. Secret missions of great diplomatic importance in Egypt, Switzerland and elsewhere were entrusted to His Highness, and enemy anger found scope not only in bitter newspaper attacks but in designs upon his life. His great influence was reinforced by his close and intimate contact with leading Allied statesmen and the breadth and liberality of his outlook on the problems of reconstruction. His remarkable study of Indian and Middle Eastern affairs in *India in Transition* (1918) was not without considerable effect in the final shaping of reforms under the India Act of 1919, and was consistent in broad principle with his post-war criticisms of the British Government's Mesopotamian and Arabian policy.

The Aga Khan laboured unceasingly to secure mitigation of the Allied terms toward Turkey, and joined in many representations, public and private, both at the Peace Conference and subsequently, as to the immense importance to Great

Britain, the ruler of the greatest aggregation of Moslems in the world, of not depriving Turkey of a real independent existence. But the issue was complicated by many considerations, and British statesmen seemed less ready to accept his advice in peace than to use his influence in war. To the G.C.I.E. and the G.C.S.I. there was added in 1916 a salute of 11 guns and the rank and status of a first-class chief of the Bombay Presidency, the only previous instance of the grant of a salute outside the Indian territorial ruling families being that of the first Sir Salar Jung. (F. H. Br.)

**AGLIARDI, ANTONIO** (1832-1915), Italian cardinal and diplomatist (see 1.377). Noted for his strongly patriotic sentiments, he actively opposed the Temporalist tendencies which prevailed at the Vatican during a part of the pontificate of Leo XIII. At a time when clerical influences in France aimed at a restoration of the Temporal Power, Agliardi was frankly favourable to the Triple Alliance as the best guarantee of Italy's territorial integrity, and he eventually succeeded in convincing the Pope of the hopelessness of his schemes. With Leo's subsequent social-Catholic activities he was in hearty sympathy, and contributed much to their success. He enjoyed the personal friendship of many of the most eminent men in Italy, including Luigi Luzzatti, Antonio Salandra and the Marquis di San Giuliano. He died in Rome March 19 1915.

**AGRICULTURE** (see 1.388). In the separate articles on different countries of the world, their agricultural progress between 1910 and 1929 is dealt with. Here will be considered (1) the progress of scientific research generally, (2) the agricultural administration and regulations in the United Kingdom, and (3) the developments in the United Kingdom during the World War. Developments in the United States 1910-21 are described under the heading *Agriculture* in the article UNITED STATES.

#### I. PROGRESS OF SCIENTIFIC RESEARCH.

During 1900-20 scientific research upon the soil was in the main directed to two sets of phenomena—the interaction of the various groups of organisms living in the soil, and secondly the relation of the various soil constituents to water as a means of interpreting the physical behaviour of the soil under cultivation.

*Soil Research.*—Dealing first with the latter question, it has long been obvious that the crude view which regards the soil as a mere mechanical foundation for the plant containing a certain amount of plant food—nitrogen, potash and phosphoric acid determinable by analysis—must be abandoned. Infertile soils disclose in the surface layer sufficient plant food for a hundred full crops, and even the later modification of the hypothesis which laid stress not on the "total" plant food in the soil but on the amount that was "available," i.e. soluble in some dilute medium such as carbon-dioxide-charged water and a solution of an organic acid akin to the cell sap of the plant, failed to provide a means of measuring fertility by chemical analysis. It was the failure of this chemical theory of the soil that led the American investigators, Whitney and Cameron, to propound the view that what really matters in the soil is its water relationships. The plant's roots feed in the soil solution, the liquid medium held on the surface of and between the soil particles by surface tension, and as this solution is always saturated, e.g. with phosphoric acid and potash of which any soil contains more than the soil solution is capable of dissolving, then the actual amount of these constituents in the soil (above a certain very low minimum) and the extra amount supplied by fertilizers are matters of indifference. Apart from some other factors, it is the water supply that determines the growth of the plant and therefore the fertility of the soil. In its turn this hypothesis breaks down, because it takes too simple a view of the process of solution in the soil, which it regards as a mixture of definite compounds possessing a definite solubility like sodium chloride or other inorganic salts. Actual experiment showed that whenever soil extracts were prepared from soils of different fertility or when even the solutions actually existing within the soils could be removed by mechanical means, they displayed a varying concentration in phosphoric acid and potash. Moreover the growth

of plants in such extracts is, within limits, proportional to the amounts of the nutrient constituents they contain.

The value of Whitney's and Cameron's suggestion lay in the way it directed attention to the soil solution as the seat of nutrition of the plant, and our ideas as to the character and formation of that solution have to be revised in the light of our more recent conceptions of the nature of colloids. A study of the behaviour of any soil towards water, whether we examine such a character as the rate at which water will drain through the soil or the rate at which successive portions of water will be removed from it by evaporation under constant conditions, shows that the soil does not behave as if it were a mixture of mere rock particles of various grades of fineness. An artificial soil built up of particles of ground quartz of the same order of sizes as the soil behaves quite differently towards water, no again does a soil that has been ignited to a red heat. In the natural soil a number of the particles, especially those of the smallest size, exhibit colloid properties, which roughly means that they have a special power of holding water on their surfaces more and more tightly as the amount of water diminishes, and also of holding and withdrawing from solutions, the ions, sometimes basic, sometimes acid, of salts. These colloids are probably the particles of compound aluminium silicates resulting from the decomposition of the felspars in the original rock basis; they are akin to the zeolites which can be found in a pure state. The humus or organic matter of the soil is also largely colloid, but the inorganic colloids themselves will account for most of the properties of the soil.

As regards the water itself, the colloid theory explains certain facts which had much occupied the attention of the American investigators who have been studying the relation of plants to soil under arid conditions as a means of extending cultivation upon the bad lands. Sachs had long ago shown that a plant would begin to wilt and be unable to take water from the soil before the soil was absolutely dry, again that a clay soil would hold water against the plant much more strongly than a sandy soil, wilting occurring when the clay soil has still 8% or more of water in it, whereas the sand will lose water down to 1% before the wilting begins. Various attempts have been made to correlate the "wilting coefficient" of the soil, i.e. its proportion of moisture when wilting sets in, with the "hygroscopic moisture," i.e. the amount of water a dry soil will absorb when in contact with a saturated atmosphere, and with the amount of water the soil holds when wetted and allowed to drain. But none of these conceptions mark any change of state; for example the curve expressing the rate at which evaporation will take place from the soil is a perfectly smooth one without any discontinuities, and the points denoting the wilting coefficient or the hygroscopic moisture are only particular positions of equilibrium between the water-holding power of the soil particles and the external set of forces tending to remove water. In the same way the distinction between the water held by the colloids and the "free water" in the soil, the latter being regarded as something different in kind and sharply marked off from the colloid water, cannot be maintained. The colloid "gels" must be regarded as imbibing water and exercising some attractive action on all the water in the soil, though that attraction is infinitesimal when the soil is saturated and only becomes a measurable force when the water has shrunk to small proportions.

The colloids that hold water in the soil are also the agents which control the composition of the soil solution upon which the plant feeds. If the soil colloids are brought into contact with a solution of any of the fertilizer salts (except the nitrates with which the action is very slight) there is an instantaneous absorption of ammonia, phosphoric acid or potash as the case may be, that is never complete, the extent being determined by such factors as the relative mass of the soil and the fertilizer, the concentration of the solution and the nature of the accompanying ions, e.g. carbon dioxide in the soil solution. Speaking broadly, a fertile soil is one possessing a high absorptive capacity, that is as it were pretty fully charged, so that the equilibrium with the soil solution is mobile and the soil colloids part freely with their nutrients to the solution as its strength is reduced through withdrawals by the plant's roots. The analytical methods which attempt to determine say the "available" phosphoric acid by attacking the soil with weak acids really determine something much more complex in which the absorptive power of the soil plays a part. The acid, whatever its nature, first dissolves all the phosphoric acid, and then there is a reabsorption, the amount of which is conditioned by the nature and strength of the acid employed. Thus the result obtained is an empirical one, valid only for comparisons of soils of similar type and constitution, to which limited degree it is of service.

*Living Organisms.*—The study of the living organisms of the soil has resulted in some reconsideration of the views formerly held as to the relative importance and function of the different groups. Among the earliest of the organisms associated with the soil to be specifically studied were those concerned with the process of nitrification and responsible for the conversion of ammonia (resulting from the breaking down of organic compounds of nitrogen by other bacteria) first into nitrites and then into

nitrate. It was held that as plants (other than the legumes) practically take in all their nitrogen as nitrates, then the rate of nitrate-making or the nitrifying power of a soil would be on one side at least a measure of its fertility. In the course of the experiments on the partial sterilization of soil by heat or antiseptics it has become apparent that the nitrification organisms are very susceptible and may be killed off while the ammonia-making organisms are still active. Again acid soils have been found in which nitrates are not produced. Yet in such soils plants grow freely, taking in their nitrogen as ammonia, not as nitrate. It becomes clear that nitrification is only the end process, and the rate at which it will proceed is determined in a normal soil by the rate at which the other organisms supply ammonia. This is seen from the fact that nitrates will heap up in the soil, whereas the ammonia remains comparatively constant at a very low level provided that the soil is normal and nitrification is going on.

For a long time the only organisms capable of "fixing" nitrogen, i.e. bringing the free gas from the atmosphere into combination, were the so-called "nodule" organisms (*Pseudomonas radiciicola*) discovered by Hellriegel and Willarth, which live in symbiosis with the leguminous plants. More recent investigations have discovered methods whereby these organisms can be grown and made to fix nitrogen independently of a host plant, and have also cleared up the forms in which they exist in the soil and find their way into the roots of the leguminous plant. The attempts to improve the growth of leguminous crops by inoculation with strains of the particular organism have not been attended with any practical success, though soils, generally of the new or reclaimed order, destitute of the nodule organism, can now be effectively inoculated and thereby made to grow good crops of legumes, provided always that the soil is first made a fit medium for the organism by a supply of lime and appropriate mineral manures. Without this preliminary acid heath or peat soils would neither support the nodule organisms nor the leguminous crops and inoculation would be of no avail. But as "fixers" of nitrogen apart from the leguminous plants *Pseudomonas radiciicola* is ineffective compared with a widespread group of organisms isolated by Beijerinck, to which he has given the name of *Azotobacter*.

*Azotobacter*.—These organisms, found in both virgin and cultivated soils from all parts of the world, are comparatively large oval bodies 4 to 5  $\mu$  in length and 3  $\mu$  in width, which differ from normal bacteria in containing glycogen and act as powerful agents for the oxidation of the sugars and other carbohydrates. From the carbohydrates they produce in the main carbon dioxide and water, but also small quantities of organic acids and of a characteristic deep brown pigment. It is by means of the energy derived from the oxidation that they are able to bring nitrogen into combination and the nitrogen fixed under favourable laboratory conditions may amount to 1% of the carbohydrate oxidized. To be effective *Azotobacter* requires certain conditions—a neutral medium with calcium carbonate present to neutralize the acids produced, for which reason the organism is generally absent from acid soils, also the presence of such nutrients as phosphoric acid and potash, and finally a favourable temperature. It has been found at Rothamsted that a soil will accumulate nitrogen, as evidenced by an increased crop, after the application of starch or sugar, carbohydrates containing no nitrogen, if these materials are mixed with the soil in the early autumn when the land is still warm and *Azotobacter* is active. On the other hand spring applications of carbohydrates are followed by a diminished crop, because at a low temperature other organisms in the soil which are consumers of combined nitrogen, attack the carbohydrate and by their multiplication withdraw some of the soil nitrogen from circulation and so reduce the supply for the crop.

The great significance of these observations of the mode of action of *Azotobacter* is that they afford a solution of the problem of how the great stocks of combined nitrogen came to be accumulated in virgin soils, especially in certain black soils such as occur on the prairies and in the Canadian North-West. Of itself the mere growth and dying down of vegetation for however many years repeated, could

not add to the stock of combined nitrogen in the soil. The plant itself fixes no nitrogen, but only draws upon the capital in the soil, restoring whatever it took out when the vegetation is allowed to die back to the soil without loss. But the falling vegetation contains carbohydrates derived from the air and if they are added to a soil containing *Azotobacter* under conditions favourable to its growth, the carbohydrate supplies the energy whereby the *Azotobacter* can fix some more nitrogen from the air and add to the stock in the soil. In this way the annual cycle of vegetation when the leaves fall back to the soil can result in a yearly accretion of nitrogen which in time may amount even to the remarkable accumulation found in the deep black soils of Manitoba and similar "steppe" lands, soils that are invariably found to be well supplied with carbonate of lime and also to contain the *Azotobacter* organism. The clue to this interpretation of the accumulation of nitrogen in virgin steppe and forest soils was derived from the examination of the soils of the wheat field at Rothamsted. The soil of the unmanured plots which has been in arable cultivation for over half a century shows a steady decline in the amount of nitrogen it contains, a decline which is approximately equivalent to the nitrogen which is known to have been removed in the crops harvested year by year. Doubtless the soil has suffered other losses of nitrogen by drainage, removal of weeds, etc., that cannot be estimated, but the analysis of the soil shows that any recuperative processes which may have been at work restoring nitrogen to the soil have only been able to repair these minor losses but not to restore any of the nitrogen removed in the crops. A portion, however, of the same plot was allowed to go to waste, i.e. it was allowed to cover itself with a natural vegetation of weeds and grasses, which were neither cut nor grazed but allowed to die back to the soil. After 30 years an examination of the soil of this wilderness showed it had been accumulating nitrogen at the rate of nearly 100 lb. per ac. per annum, the greater part of which must have been due to the action of *Azotobacter* working upon the carbonaceous matter supplied by the decaying vegetation reaching the soil in the autumn and winter.

On the arable land where the vegetable matter reaching the soil is minimal, only the roots and stubble of the crop, there is a steady loss of nitrogen; on the wilderness which may be compared to a natural prairie, the return of the vegetation to the soil causes nitrogen to accumulate not because of the nitrogen contained in its material, but because its carbonaceous matter supplies the energy whereby the *Azotobacter* fixes nitrogen. The *Azotobacter* group of organisms, though not the only ones capable of bringing free nitrogen gas into combination, constitute the group which has played the fundamental part in building up not merely the vegetable soil but the whole substratum of organic life in the world.

*Soil Protozoa*.—The outlook on the organisms in the soil has been entirely changed since Russell and Hutchinson showed the part played by the protozoa in limiting the development of bacteria in the soil. The soil protozoa, which are large, definitely animal organisms of varied character—amoebae, ciliates and flagellates—exist in large numbers in all cultivated soils, and as they feed upon bacteria, any conditions which encourage the development of bacteria by increasing their food-supply stimulate the multiplication of the protozoa which thereby put a check to the increase of the bacteria. Thus normally the number of bacteria in a soil, however rich and favourable to bacterial development the conditions may be, does not pass a certain limit because it is kept in check by the increasing number of the protozoa. As the fertility of the soil among other things depends on the rate of production by bacteria of ammonia and nitrates from the nitrogenous residues in the soil, the fertility of the soil is also limited by the presence of the protozoa. Certain processes of partial sterilization of the soil, such as heating to the temperature of boiling water or even to 170° F. or again treatment for a time with some antiseptic, e.g. chloroform or toluene vapour, effects a selective destruction of the soil organisms. The protozoa are almost entirely killed off, but many groups of bacteria, notably the ammonia-makers, resist destruction though they may be reduced in numbers. But if after treatment the treated soil is placed under normal conditions for growth, the bacteria that remain multiply with great rapidity and rise to a level of numbers and activity they were unable to attain before, because now the protozoal check to their multiplication has been removed. In consequence the fertility of the soil is greatly increased, in fact the yield from a given soil may be doubled. This discovery suggests immense potentialities of increased production from the land but as yet it has not been found possible to apply the method of partial sterilization to ordinary field soils in the open. Heating would be inordinately expensive and the difficulty is to find an antiseptic that combines cheapness with the right degree of

volatility and stability against the attack of bacteria. In green-houses, however, where the soil soon becomes "sick" through the excessive development of protozoa under the favourable conditions of moisture, temperature and manurial enrichment, the sterilization of the soil by heat has been worked out as a commercial process and is now part of the routine of all progressive cultivators under glass.

**Microfungi.**—Great as is the attention that is now being given to the soil organisms in all agricultural laboratories these would appear to be room for more work upon one group—the micro-fungi, of which there is a large flora in the soil.

It has been shown that when from one cause or another a soil becomes acid, many bacteria concerned in the decay of vegetable matter are entirely inhibited and may disappear. Fungi instead take up the work, but the broad character of the process thereby changes, the vegetable matter is not burnt away as carbon dioxide but in part accumulates in the form of peat. The formation of a peaty material is in fact a concomitant of an acid reaction in the soil and the activity of microfungi rather than of bacteria, and this generalization fits in with many observations of the character of peat deposits.

Often trees are found at the base of these beds where trees no longer grow; and it may be surmised that the trees grew on the original neutral land surface when it became fit for vegetation after the close of the glacial epoch. That soil being of a non-calcareous nature gradually accumulates acids arising from the decay of the vegetation falling upon it; whereupon under the prevailing climatic conditions the further vegetable debris reaching the soil began to form peat. This accumulation of peat in its turn brought about the death of the forest.

**Nitrogen.**—During 1910-20 agriculture received great benefit from the working out of processes on a large scale for bringing nitrogen into combination, processes which thus supplement the comparatively limited sources of nitrogen compounds afforded by the Chile deposits of nitrate of soda and the ammonia which is recovered as a by-product from the distillation or combustion of coal.

Prior to the World War two processes had been established commercially. At Notodden in Norway air is driven into a specially formed electric arc which results in the combination of nitrogen and oxygen so that the issuing gases contain about 1.25% of oxides of nitrogen which are then absorbed by passing up towers where they meet an absorbing stream of water or milk of lime. The product, nitrate of lime, contains about 13.5% of nitrogen, and is a most valuable fertilizer, quite as effective as nitrate of soda and on some soils more suitable.

At about the same time as synthetic nitrate of lime was introduced, another nitrogenous fertilizer began to be manufactured on a large scale, calcium cyanamide or nitrolim. The body arises from the combination of calcium carbide at a temperature of about 600° between calcium carbide and pure nitrogen gas under slight pressure, with the resulting formation of a compound which in the soil decomposes mainly into ammonia and calcium carbonate. Cyanamide as a fertilizer requires a certain amount of care in use and on the majority of soils has not proved so effective as nitrate of soda or sulphate of ammonia. Its manufacture, however, received an immense impetus during the World War, as it was the simplest and most readily available process for bringing nitrogen into combination, from which by further steps ammonia and then the nitrates and nitric acid required in explosives could be obtained. The United States and many European countries have immensely developed the manufacture of cyanamide, which must in future be available as fertilizer either used directly or after prior conversion into some convenient compound of ammonia.

The war period was also marked by the development on a gigantic scale of a new process, which had only been finally worked out to the manufacturing stage in Germany in 1913—the Haber process of bringing nitrogen and hydrogen into combination as ammonia. In the presence of a suitable catalyst of activated iron the elements will unite at pressures of 250-300 atmospheres and a temperature approaching 500° C. to the extent of 8% or so of the mixed gases. The ammonia can be removed and the remaining gases passed round again into the catalyser. Great as are the difficulties of working at these temperatures and pressures the Haber process is cheap in power and materials. It was the mainstay of the supply of combined nitrogen for explosives to Germany during the war, and should become a most important future source of fertilizer to the agriculturist.

During the war the demand for nitrogenous fertilizers greatly increased in all countries; the United Kingdom for example increased her consumption of sulphate of ammonia from 60,000 tons to 265,000 tons per annum, part of this being of course substitution for the pre-war use of 80,000 tons of nitrate of soda, which was no longer available. Potentially, however, the establishment of so many war plants for the manufacture of synthetic nitrogen products

has increased the supply of nitrogen available as may be seen from the following table:—

	Metric Tons of Nitrogen		
	Output 1912	Output 1917	Productive Capacity 1920
Chile Nitrate	411,329	465,000	471,000
Ammonium sulphate (by-product)	272,007	340,000	413,000
Cyanamide	22,435	190,000	325,000
Haber process	.....	100,000	308,000
Arc process	9,997	27,000	33,600
	715,678	1,122,000	1,550,600

It should be noted, however, that the 1920 figures are not actual but only potential supply, if existing plants are worked up to their capacity.

**Potash.**—As the only extensive potash deposits in the world that had been commercially developed—Stassfurt and Alsace—were in German hands, there was during the war a great shortage of potash fertilizers outside central Europe. Great efforts were made to develop processes for the extraction of potash from feldspars and other natural sources, but without much success.

The only method which proved of value was the discovery made in the United States that the dust which accumulates in the flues through which the gases from blast furnaces are led contains a not inconsiderable amount of potash in a readily soluble form, one-half indeed consisting of sulphates and carbonates soluble in water. Different grades of flue dust can be collected; the finest is a cream-coloured material containing as much as 60% of potash. The dust was collected and used for agricultural purposes during the war though only some 15,000 tons per annum were obtainable in Great Britain. It is now worked up for industrial purposes, but the output of potash salts from this source cannot exceed a few thousand tons per annum in the United Kingdom. The supply of potash salts for agricultural purposes since the war has been entirely changed by the transfer to France of the Alsatian deposits which occupy an area of some 77 sq. m. between Mühlhausen and Colmar in Alsace. This deposit consists of two beds, the upper about 4 ft. thick, the lower about 1½ ft., which form practically unbroken strata at an approximate depth of 1,800 ft. and present no difficulties in mining. The material is very uniform in composition, consisting in the main of sylvinite, mixed chlorides of potassium and sodium, containing about 20% of potash reckoned as K<sub>2</sub>O. It can be used for agriculture in its crude state and though the development of the field is still very incomplete the former German monopoly of potash supplies is thereby broken down. Another extensive deposit is known in Spain, but it has not reached the stage of commercial development and is generally considered to be controlled by the German company which works the Stassfurt deposits.

**Superphosphates.**—During the war the manufacture of superphosphate in the United Kingdom was considerably restricted, on the one hand by the withdrawal of sulphuric acid for the manufacture of explosives, and on the other by the shortage of tonnage for the importation of phosphate rock. American supplies were completely cut off and receipts from the North African deposits fell to something like 500,000 tons per annum. In consequence British farmers were compelled to resort mainly to basic slag of which this country produced about 400,000 tons per annum, though prior to the war only some 280,000 tons had been consumed by British agriculturists. With the extended programme of arable farming the demand for phosphatic fertilizers was greatly increased and the whole of the basic slag produced at home was absorbed, though the output was increased to as much as 565,000 tons from the year ending May, 1919. Unfortunately this increase in amount was accompanied by a decline in character, owing to changes in the processes generally adopted for making steel.

The Bessemer process has been almost displaced by the open-hearth process which produces a slag less rich in phosphoric acid. The practice has also been adopted of adding fluo-spar to the furnace in order to induce the formation of a more fusible slag, but thereby the solubility of the phosphoric acid of the slag in the weak citric acid generally used in testing its quality becomes impaired. The bulk of the basic slag now sold contains only about 10% of phosphoric acid against 15 to 20% in the older types of slag and the phosphoric acid is no longer soluble in weak acids. The new type of basic slag proves, however, little less effective, unit for unit of phosphoric acid, as a fertilizer, but freight charges, always a large item in the cost of basic slag to the farmer, now become doubled for the amount of phosphoric acid that is carried, apart from the increase in these



charges per ton. Attempts were in 1921 being made to replace basic slag by finely ground mineral phosphates as a fertilizer for grass land. American experience has always been favourable to these ground phosphates, and recent experiments in England have demonstrated that they effect in poor pastures the same encouragement of clover as is obtained from basic slag, even upon such unpromising land as the clays in the dry Essex climate. The phosphate rock from Nauru Island, that has passed from German hands into the control of the British Government, may prove of special value for application in this finely ground but otherwise untreated condition.

**Plant Breeding.**—Probably the plant breeders have during 1900-20 rendered the greatest services to agriculture; inasmuch as improvements in this direction—the introduction of new varieties giving large yields, better quality and more resistant to disease—are at once appreciated by the farmer and require no alterations in the methods of cultivation. It has been found possible to apply Mendelian principles with comparative simplicity and accuracy to the breeding of new varieties of plants, especially of cereals, and the results achieved have already experienced considerable commercial development in the case of wheat, barley, oats, maize, sugar-cane and cotton. The value of the Mendelian principle lies in the power it gives of combining in one of the selected descendants of a cross-bred individual unrelated valuable characters possessed by the parents separately.

In the case of wheat Biffen has shown that among the Mendelian characters that are transmitted as unchanged units are such quantitative properties as the resistance to disease, the normal percentage of nitrogen in the grain and the "strength" of the flour resulting from it, the stiffness of the straw, etc. One of the chief desiderata as regards English wheat has been an improvement in its strength, i.e. the capacity to yield a spongy elastic dough which will bake into a light loaf of large volume. This strength factor which is connected with the amount of gluten and therefore with the percentage of nitrogen in the flour is as a rule the property of spring wheats grown in a "stepped climate" with a short period of growth, with considerable rainfall in the early months exchanged for great heat and almost complete dryness before harvest. Wheats from Hungary, South Russia, Manitoba and the great plains of North America possess this quality, and Leclerc and Leavett have shown by sowing the same seed in different states how potent is the effect of environment and climate in determining the percentage of nitrogen and the strength of wheat. As a rule any of the strong wheats brought either from continental or American sources lose their strength completely when grown under English conditions. One wheat, however, of Galician origin but widely grown in America under the name of Red Fife, so widely indeed as to be the dominant constituent of such commercial grades as Manitoba and No. 1 Northern, does to a large measure retain its strength in England; the strength in this case being congenital and not the product of environment. Red Fife is, however, a poor cropper on most English soil, yielding but 3 q. per ac. where the typical English wheats will yield four or five. Biffen has, however, employed it as a parent in the hope of combining the strength of the one parent with the cropping power of the other and one of the results of this cross, a wheat called Yeoman, issued to the public in 1915, is on its congenital soils—the warmer and better soils of the east and south-east of England—probably the heaviest cropper grown. Further, the quality of the grain is so high that the miller can use it without any mixture of strong foreign wheats, such as are necessary to the extent of 40% or more with ordinary English wheat. Another of Biffen's wheats, Little Joe, by its power of resisting rust, has proved a very heavy cropper and is now extensively grown on soils that remain fairly dry and warm throughout the winter. Saunders in Canada has effected a very considerable extension of the wheat area by the introduction of a wheat called "Marquis," another hybrid with Red Fife as one parent, which combines the good quality of Red Fife with a shorter period of growth and an earlier ripening habit, thus rendering wheat-growing safe in wide areas, as in parts of Alberta, where the crop was liable to ruin through the onset of early autumn frosts before harvest had been completed. On the average Marquis ripens six days earlier than Red Fife and thus in the Central Prairie region where frosts are expected between Aug. 27 and Sept. 2 Marquis can generally be grown safely though Red Fife is liable to be caught. In part the extension of Marquis may be put down to its superior cropping powers, but for one reason or another it has largely displaced all other spring wheats in the North-West. In 1918 the area under Marquis in Minnesota, the Dakotas, Montana, Manitoba, Saskatchewan and Alberta was estimated to amount to 20,000,000 ac and the crop in Canada alone to 129,000,000 bus.—all the produce of what was but a single plant in 1903!

**Immunity from Disease.**—The inheritance of immunity from disease is best illustrated by the discovery of potatoes immune to wart disease.

About 1897 attention was drawn to the prevalence in certain

parts of England and Wales of a disease of potatoes, generally found in old cottage gardens and allotments, which causes the potatoes to degenerate into a mass of dark corky excrescences and will in bad cases destroy the crop entirely. The disease is due to the attack of a lowly organised fungus, and the difficulty of dealing with it is due to the fact that once established in the soil the spores or some resting form of the fungus retain their life for an indefinite period of many years. Once the soil has become infected no practicable means has been found of cleaning it; even leaving the land down to grass for ten years has been found ineffective. Considerable areas in the industrial districts of Lancashire, Cheshire, Stafford and Shropshire, North and South Wales are subject to the disease and it became more widely distributed throughout the West of England as a result of the great shortage of seed potatoes in 1917, which caused men to plant anything that was available without inquiring into its origin.

The consequences would undoubtedly have been the complete destruction of potato-growing in those districts had it not been observed that one or two types of potatoes could be found growing unharmed in some of the old infected gardens. Further examination proved that these varieties were really immune to the disease, however heavily infected the soil, and though in themselves they possessed little commercial value they were at once employed as seed parents and have become the source of a new race of potatoes immune to wart diseases. Many of these are now proving to be good market varieties of heavy cropping power and by their aid potato-growing has been rendered possible in the infected areas which otherwise inevitably would have spread until the whole country would have been involved. As the disease has also obtained a foothold (its original habitat is unknown) in North America, Holland, Belgium and Germany, the value of this discovery of immunity is difficult to overestimate. From the study of this and other cases the conviction gains ground that the most fruitful method of dealing with plant disease will always be by the search for immunity rather than by methods of treatment.

**Selection.**—In the improvement of cereals considerable advantages have been derived by working on another principle than that of breeding, i.e. pure line selection. Very little improvement in a variety can be effected by what may be called "mass selection." If in going over a field of wheat a collection is made of the longest ears, or again if the heaviest grains are sorted out, no perceptible improvement is visible in the crop grown from the selection, not even if the process is repeated generation after generation. The superiority of the individuals selected has been due to some accident of nutrition and is not transmissible to the offspring. If, however, the selected individuals are sown separately, here and there among them will be found one which in the next and succeeding generations still preserves some superiority which is congenital to it and is maintained in succeeding generations even when the seed is worked up to a large crop.

An ordinary variety, say of wheat, really consists of an indefinite mixture of sub-varieties each of which, for many generations at least, breeds true in the case of cereals which are self-fertilized. Thus "pure lines" may be selected from single seeds of such self-fertilized plants and worked up to commercial stocks of seed. These pure lines may have some superiority, never, however, great, in cropping power over the mixed variety from which they are derived, and are also appreciably more uniform in such details as time of ripening and length of straw.

It has become evident that every commercial variety of cereals, even if of deliberately cross-bred origin, will be improved by pure line selections from time to time.

**Nutrition.**—It was still difficult in 1922 to discuss in any detail the progress that is being made in the study of animal nutrition, in regard to which the teachings of the scientific man have had much less effect upon the practice of the farmer than has been the case when the nutrition of the plant has been concerned.

The great shortage of cattle food during the war, notably in 1917 and 1918 when no tonnage could be imported for cattle food, did reveal two things, first, the dependence upon imported corn and oil seeds that British meat and milk production had fallen into, and secondly, the enormous waste that had been going on. It was estimated that the normal output of meat, milk and other animal products did not represent one-half, possibly not more than a third, of the amount that could have been obtained, not merely theoretically, but even if properly informed practice. At the same time certain lacunae in our theory were disclosed, which prevent the scientific man from setting out with any accuracy the limits within which the fattening of animals will proceed most economically. It will be seen that the problem is a very complex one. On the one hand, as regards the amount of food fed over and above the maintenance ration, the law of diminishing returns is found to hold for the amount of daily increase; on the other hand, the slower the rate of fattening, the

greater must be the non-productive consumption of food on maintenance only.

Again in the later stages of fattening the law of diminishing returns operates in another fashion, in that the increase of weight may be put on as offal fat of comparatively low value instead of as edible fat in the "meat" portions of the carcass. Much more exact information is therefore being sought as to the relations of the live weight increase to the progress in consumption of food and again to the changes in the composition of the carcass as the fattening process advances.

On the other side of the nutrition question recent work upon "vitamines" and accessory food factors is found to have its application to questions of animal nutrition. Not only the health and growth of certain animals, notably pigs, is in practice affected by the deficiency of the foods habitually used in these accessory factors, but again the fats arising from the animals, e.g. lard, bacon, even milk and butter fat, may in their turn become deficient as human foods because of the lack of the accessory substances in the food of the animal. Enough work has been done to show that in certain special cases of indoor feeding of animals not only the broad energy- and tissue-forming properties of the food have to be considered, but also the supply of certain accessories—energizers or detonators, whatever may prove to be their function. In practice the path of safety for all farm animals lies in a reasonably mixed diet, which includes some proportion of uncooked green food. Pigs and poultry have not infrequently been sufferers from diets insufficiently supplied with vitamins.

**Animal Breeding.**—Although in 1921 such progress had not yet been made with the very complex subject of animal breeding as to enable economic results to be obtained similar to those which had accrued in plant breeding, still the ground was being prepared by certain initial investigations for the mode of inheritance of some of the desiderated qualities in domestic animals, e.g. size, prolificacy, quality of wool, etc.

Punnett, for example, in England has thrown some light on the inheritance of size in fowls and rabbits, and again on the inheritance of fur, but by far the most important work in this direction has been done by Pearl in Pennsylvania. In studying the inheritance of milk yields he has first of all endeavoured to obtain a single figure characterizing the performance of a cow, a sort of index number. By a study of commercial milk records he has constructed a type curve showing the variation in milk yield for a cow during successive calvings, whereby if its milk yield in any one year is known this figure can be corrected to give the milk yield in the standard year used for comparison. A similar type curve can be constructed for the period of a lactation, whereby the yield for the whole period can be deduced from the yield ascertained during a particular month or less. Having thus obtained characteristic figures for cows, Pearl was in a position to compare the performances of cows with their offspring by different bulls. By tabulating all such comparisons obtainable with regard to a particular bull a characteristic mark is obtained for the bull. Some bulls are found always to bring about an increase in the milk production of the daughter over the dam; other bulls which had a great repute in their day and a fine record in the show yard equally invariably gave progeny yielding less milk than their dams. The value of this work in connexion with milk recording and breeding is evident; indeed in Denmark for some years the underlying principle has been appreciated in that prizes are offered for bulls, the award being based upon the milk tests of the bull's progeny. The difficulty attaching to the application of these results lies in the disinclination of farmers to retain bulls for service for more than two or three years; they are cast before there is any opportunity of testing the milk-producing quality of their offspring. (A. D. H.)

II. ADMINISTRATION AND LEGISLATION IN THE UNITED KINGDOM

As was inevitable, the World War gave rise in all countries to a great body of emergency enactments and temporary legislation affecting agriculture. Beyond those, however, the years 1917-21 saw a large volume of legislation which aimed at the reorganization of agriculture in Great Britain, and also inaugurated a definite agricultural policy, the main features of which found expression in the Corn Production Act of 1917 and the Agriculture Act of 1920. The principles underlying these Acts first were set out in the report of the commission appointed in 1915 under Lord Milner, and still more fully in the report of the sub-committee of the Reconstruction Committee under the chairmanship of Lord Selborne.

Briefly, these committees found that the position of the United Kingdom had, as demonstrated by the war, fallen into great insecurity in consequence of the neglect of agriculture which had been going on during the previous 40 years. In 1872 the arable

land in the United Kingdom amounted to nearly 24,000,000 ac., and this had become by 1914 little more than 19,000,000 acres. The loss had been experienced chiefly in England and Wales, where the shrinkage had been nearly 4,000,000 ac., from 14,943,000 to 10,998,000 acres. This represents a great decline in the gross production of food, because it has been abundantly demonstrated that an acre of medium land under grass does produce only about one-third of the meat or milk that can be obtained from the same land if it is put under the plough and the crops are consumed by stock. Moreover, whenever there is a definite shortage of food the production of meat is in itself a wasteful process, from seven to ten pounds of real food being consumed by the animal in making one pound of food in the shape of meat or milk. The only gain in meat production is that the animal is able to convert coarse fodder like straw and waste materials like millers' offals into human food, but an animal like a pig, which is largely fed upon barley and maize meal, equally edible by human beings, becomes definitely wasteful of the resources of the country when a real food scarcity is declared. The comparison between the productiveness of grass and arable land may perhaps be illustrated most markedly by a consideration of the potato crop. An average yield of potatoes in England is about 6½ tons per ac., which represents over 2,000 lb. of dry food when all allowances have been made for waste. Under grass the same land would not produce more than 120-150 lb. of meat, i.e. about 100 lb. of dry food, or 160 gal. of milk, i.e. 170 lb. of dry food. Nor does the animal food, pound for pound of dry matter, possess more than a slight superiority over the potatoes in its power of maintaining human beings.

**Before the War.**—Roughly speaking, in the years immediately preceding the World War the United Kingdom was only producing about 42% of the food consumed by its people. The greater portion had to be imported, and this applied particularly to wheat of which only about one-fifth of the normal consumption was produced at home. This dependence of the nation upon external supplies of food was its great weakness revealed by the war. Not only was there the danger that the German submarine campaign might prove successful and force submission by starvation, but, even as it was, the country's effort was hampered by the necessity of allocating to food supply so large a proportion of the available tonnage needed for other purposes and of employing part of the naval strength to protect it. Again, the purchasing power and credit of the country were continually impaired by the enormous sums spent abroad for food.

The external food bill amounted to over £20,000,000 a year before the war, and during its latter stages this had risen to three times that sum. The enemy was not slow to realize that this was Britain's vulnerable spot. The attack failed, but the economic consequences pressed grievously upon Great Britain after the war. The recovery of Britain was deferred by the enormous purchases it must continue to make abroad in order to keep its people fed, and the sacrifices it must make in order to maintain the foreign exchange at a high level in order to meet these purchases.

It had often been argued that in case of emergency the grass lands of Britain constituted a great reserve of fertility which could be drawn upon for the growth of corn and other crops, but when the occasion came it was proved how little of this reserve was immediately available. Neither the men nor the horses, not even the buildings or the implements, required for arable farming, existed any longer. All the inertia of the farming community came into play against conversion, and despite the efforts of the State, armed with compulsory powers, proffering compensation against loss and assisting with fertilizers, seeds and machines, less than a further 2,000,000 ac. of grass land got broken up during the fateful years of 1917 and 1918. Once the art and means of arable farming have been lost, it is only slowly and at great expense that they can be improvised.

Concurrently with the decline in the production from British land in consequence of the conversion from arable into grass there had been a corresponding decrease in the agricultural population, which in England and Wales alone had fallen from

1,269,371 in 1871 to 951,674 in 1901, though by 1911 it had again risen somewhat, to 1,002,743.

This reduction of the agricultural community was not to be viewed with equanimity. A population dependent entirely upon manufactures gives rise to an unstable State, subject to violent fluctuations of prosperity because the causes that determine employment are apt to affect all industries simultaneously. Politically a country population is more sober and cautious, just as it is healthier and more reproductive and both physically and temperamentally better fitted for steady enduring work.

It was these two motives then that led to the legislation under review—the desire to ensure a greater production of food and the better cultivation of British land, and the desire to increase the rural population, neither of which could be attained if the old *laissez faire* policy were persisted in.

*New British Policy.*—What had been the origin of the dangerous situation in which the nation found itself in 1914? Taking extent of the arable land as an index, the high-water mark of English agriculture was reached in 1872. The later seventies were marked by bad seasons culminating in the disastrous experience of 1879. At the same time rapid progress was being made with the opening up of the American prairies for corn-growing and with the cheapening of ocean freights. This was a period of immense expansion in the new lands of the world; it saw the growth of the Middle West both in the United States and Canada, the agricultural settlement of the Argentine and other South American lands, the development of Australian wheat-growing areas and the commercial exploitation of southern Russia. As a consequence, prices of the great agricultural commodities, corn and meat, fell rapidly and continuously during the eighties and nineties. Wheat from an average of 54s. 8d. per qr. in 1871-5 fell to 22s. 10d. in 1894; the average return per acre on an arable farm for both corn and meat, estimated at 165s. in the first period, dropped to about 100s. between 1894 and 1900. As the rate of wages rose during the period and no great compensating factor was at work (other than the perfecting of the self-binder, which had made wheat-growing for export possible in the new countries), British farming was unable to adjust itself with sufficient rapidity to the vastly diminished returns. The great depression resulted in the ruin of a large proportion of the old farmers, in a wholesale loss of capital, and, worst of all, in an entire loss of confidence in an industry that had ceased to control the prices of its main products. The industry met the situation by a drastic reduction of expenditure and the conversion of arable land into grass on which the labour bill was small. The process was aided by the continued development of the milk trade. From 1900 onwards the course of prices turned upwards—the world's population was growing up to the food supply, and the new farming adjusted to the changed conditions began to become steadily prosperous. But the memory of the great depression remained, confidence was small and capital mistrustful. Men hesitated to adventure their money in a business which was liable to a break of prices such as had occurred within all too recent a date. Such were the conditions that had led to the dependence of the nation upon foreign food and particularly upon foreign corn; hence the object of the policy was to give the arable-land farmer security that he should not in future be subjected to a devastating break in prices such as had occurred in the eighties and nineties of the last century. With this security in the background it was thought the current conditions would be favourable enough to bring about an extension of the arable area.

As the Prime Minister said in his famous speech to agriculturists in Oct. 1919:—

"The Agricultural Industry is the greatest industry in the State. It ought therefore to be a primary concern of every Government and of every Statesman to do what in them lies to promote that industry. I regret to say that in no civilized country has the State done so little during the last generation to foster agriculture. I hope that record will now be rolled up and that there will begin a new era in the relations of the State with the greatest and the most important of its industries. . . . The question is 'Are we going back to the dismal pre-war conditions or are we merely going to maintain the progress which has been made?' Are we not going further? There can be but

one answer from every man who loves his country. We must go forward. How is it to be done? You must have a settled policy with regard to agriculture. The first condition is security to the cultivator: security in the first place against ruin through the violent fluctuations of foreign agriculture."

*Acts of 1917, 1919, 1920.*—The method by which this security was given in the "Corn Production Act" of 1917 and the "Agriculture Act" of 1919 embodies a novel principle. Instead of a protective duty, which enhances the price to the consumer, a bounty was given to the producer if the average market price of wheat or oats fell below certain guaranteed figures. In the Corn Production Act certain guaranteed prices were set down for six years ahead, but at that time it was vain to make forecasts of the trend of prices, and actually none of the guaranteees then given ever came into operation. By the Agriculture Act of 1920 basal prices of 68s. for wheat and 46s. for oats were taken for the year 1919, and commissioners were appointed who were charged to determine from year to year how far the average costs of production of wheat and oats had changed in that year from those of the basal year 1919, whereupon the guaranteed figure of 68s. or 46s. was varied in like proportion. If for example the commissioners found that in 1923 the cost of production of a quarter of wheat was on the average 20% less than in 1919, the price guaranteed by the Act would become 54s. 5d. Should then the average price actually obtained by farmers, as ascertained by the official corn market returns from Sept. 1 to March 31, amount to 52s. 11d. and thus leave a difference of 1s. 6d. per quarter between the guaranteed and realized price, the Government would be liable to pay 1s. 6d. per quarter on all the wheat produced. But since the verification of the actual quantities grown presents great administrative difficulties the crop is assumed to be 4 qr. to the acre, and the undertaking of the Act was to pay four times the difference between the average realized price and the guarantee on every acre of wheat grown, five times the difference in the case of oats, on the assumption of an average crop of 5 qr. to the acre. It will be seen that the payments made to any individual were independent of the actual price he happened to obtain for his particular sample. The normal course of trade is not interfered with and the grower gets the benefit of any superiority of quality or favourable market conditions he may possess.

The guaranteees were confined to wheat and oats, not so much to increase the specific production of those cereals as to encourage arable farming, since one or both of these crops formed an inevitable part of every rotation in the United Kingdom.

Inevitably the State was involved in a considerable liability in any year in which a break in prices might occur after harvest but in which the costs of production had not been affected. These are, however, precisely the occasions dreaded by the farmer mindful of the past, and the Act was designed to give the farmer such assistance as might save him from ruin, though it would not provide a profit. The State, however, only accepted this liability in order to bring about an increase of production; it recognized an obligation towards agriculturists, but on the other hand it required that the land should be put to proper use. In the Corn Production Act the Board of Agriculture was given power to enforce proper cultivation where the rules of good husbandry were being neglected and also to dictate the mode of cultivation or the use to which the land should be put for the purpose of increasing the production of food in the national interest. In case of failure to comply with the directions the Board could cause the owner to terminate the tenancy, or, if the occupier were the owner, could enter itself and cultivate.

These somewhat drastic provisions, which were exercised under the Defence of the Realm Act during the war, were strongly opposed by both owners and occupiers and became greatly modified when the Agriculture Act of 1920 replaced the Corn Production Act. Practically under the new Act the powers of the Ministry of Agriculture were limited to the enforcement of cultivation according to the rules of good husbandry.

Where an estate is grossly mismanaged to such an extent as to prejudice materially the production of food thereon or the welfare of persons engaged in the cultivation of the estate, the minister may, after holding a public inquiry, appoint some person to act as receiver and manager of the whole or a portion of the estate, an appeal being allowed to the High Court. The Ministry's powers were delegated to cultivation sub-committees of the agricultural committees of the county councils which had been set up by the Ministry of Agriculture Act of 1919.

There was, however, another public interest to be considered—

the conditions of the labourers engaged upon the land. In order to give them security the Corn Production Act, whose provisions were renewed in the Agriculture Act, provided for the setting up of an agricultural wages board, empowered to fix minimum rates of wage for persons engaged in agricultural work, no such rate to be less than 25s. a week for able-bodied men. The wages board consisted of an equal number of representatives of employers and workmen, together with certain appointed members nominated by the Board (Ministry) of Agriculture. District wages committees were set up for administration of the Act within their areas, and these committees proposed local rates of wage and incidental regulations regarding their area for the confirmation of the central wages board. As the setting up of the wages board coincided with a time of rapidly advancing wages in all industries the minimum rates of wage were repeatedly advanced under its orders. In June 1921 the lowest rate amounted to 43s. 6d. per week of 52 hours in summer and 48 in winter, and this rate prevailed in the English counties where the average rate of wages before the war was not more than 15s. An incidental result of the wage regulation was the practical abolition of all allowances which in many parts of the country were made to labourers in lieu of cash, e.g. milk, potatoes, bacon, coal, etc. A deduction may still be made for cottages but the amount of deduction allowable is fixed by the wages board and may not exceed 3s. a week. It may be noted that with one or two comparatively small exceptions the minimum wage regulations succeeded in avoiding strikes in the agricultural industry during a period in which labour conditions were very disturbed.

The Corn Production Act, and in its turn the Agriculture Act, thus represent a definite attempt on the part of the State to frame a constructive policy for agriculture in the national interest. The two main interests concerned, the farmers and the labourers, were given some security of a return for their work, the State obtained increased production and some control over the use of the land. Should it prove, however, that even with guaranteed prices the occupiers of land were not responding by an increase of production to any payments made by the State under the guarantees, the purpose of the Act would be unfulfilled. To meet this the Act gave the Ministry power by Order in Council to give four years' notice of the determination of its powers under Part I. of the Act, which dealt with the system of guarantees, the control of cultivation and the regulation of wages.

It should be noted that the Agriculture Act contemplated the delegation of the powers of the Ministry to control cultivation to committees of the county agricultural committees which were set up by the Ministry of Agriculture Act of 1919. This was a continuation of the procedure adopted during the war, when the Board of Agriculture appointed county executive committees in order to carry out the orders under the Defence of the Realm Act for the increase of food production.

The second part of the Agriculture Act of 1920 also contained a series of provisions amending considerably the Agricultural Holdings Acts. The main feature of this legislation entitles a tenant who is given notice to quit to compensation for disturbance. This compensation amounts to one year's rent, or, if greater, to the proved loss and expenses incurred in quitting the holding, up to a maximum of two years' rent. Compensation is not payable to a tenant who was not cultivating his holding according to the rules of good husbandry, or who had failed to comply with an order to pay arrears of rent or to repair a breach of covenant. The landlord may also demand that the question of the rent payable for the holding shall be submitted to arbitration and if the tenant refuses to agree to this demand may then give him notice to quit without compensation for disturbance. The Agriculture Act applied to Great Britain only, and the procedure of the Corn Production Act in setting up an agricultural wages board for England and Wales was somewhat modified as regards Scotland and Ireland.

In 1919 the Ministry of Agriculture and Fisheries Act was passed, which, besides changing the title of the Board of Agriculture, set up a council of agriculture for England and Wales, partly elective and partly representative, which should meet at least twice a year for the purpose of discussing matters of public interest relating to agriculture and of making representations to the minister. From these councils are selected the members of the Agricultural Advisory Committee, which has the duty of advising the Ministry on all matters (except as regards fishing) relating to the exercise of the powers of the Ministry. These two bodies resemble in many respects the Council and Board of Agriculture in Ireland, though neither of them possesses that control over expenditure which the Board of Agriculture in Ireland can exercise over the expenditure of the endowment fund enjoyed by the Department of Agriculture in Ireland. The Act also provides for the setting up by the county council in each county and in certain county boroughs of an agricultural committee. These committees must set up sub-committees to deal with small holdings and allotments, with the powers to regulate cultivation delegated to them by the Ministry under the Corn Production and Agriculture Acts and with drainage under the Land Drainage Act of 1918. This committee may also, by the direction of the county council and with the concurrence of the Board of Education, take over from the Education Committee the control of agricultural education.

Land drainage for generations has been the subject of legislation, but it was evident that existing powers were inadequate to provide for the efficient management of the drainage of the majority of the river basins of England and Wales. In many areas there was a multiplication of authorities, many of whom possessed insufficient rating powers to be able to carry out works falling within their area but vital to the whole river basin. In other cases the area was inadequate or the existing commissioners of sewers failed to execute their duties. The Drainage Acts of 1914 and 1916 gave the Ministry of Agriculture powers to make orders constituting drainage districts, altering the boundaries of existing drainage areas or enlarging their powers of levying rates or borrowing. The Ministry may also act itself in default of any drainage authority or may delegate its powers to a committee of the county council or councils of the area concerned, though its power of executing any such work of drainage and of recovering from the owners affected in limited to schemes costing not more than 15,000. By means of these Acts and of the Defence of the Realm Act powers possessed by the county executive committees, much valuable work had been accomplished by 1921 in cleaning out the smaller watercourses and improving the drainage of many minor areas subject to flood or unfruitful because of waterlogging. Larger schemes exist for dealing comprehensively with important areas like the Ouse basin, which embraces some of the most valuable land in the Fens, but these schemes are likely to remain in abeyance while the difficulties of financial stringency and high cost of labour prevail.

One of the heaviest tasks which was assigned to the Board of Agriculture at the close of the war was the settlement upon the land of such ex-service men as desired holdings and could show their suitability to occupy land. Under the Small Holdings and Allotments Act of 1908 county councils had been empowered to purchase land and equip it for small holdings, but it was necessary that the schemes they framed for this purpose should show a reasonable prospect of being self-supporting on the rents that could be expected. It was evident, however, at the close of 1918 that little settlement of ex-service men could be effected upon such terms. Not only had the price of land, especially of land suitable to small holders, increased very largely, but the cost of buildings, equipment and adaptation, necessary in the majority of cases before a small holder can be placed upon the land, had grown to three or four times its pre-war magnitude. No such rents could be charged as would make the small holdings pay, nor could county councils be expected to burden their rates with the losses that would accrue if the holdings were let at reasonable rents. Accordingly, by the Land Settlement Act of 1919, the State accepted of this liability and allotted a sum of 20,000,000 for the provision of holdings for ex-service men. The Act retained the county councils as the agencies for the provision of small holdings, and strengthened their powers to acquire land compulsorily for the purpose by purchase or by hiring. In the main the 20,000,000 mentioned above has been lent to the county councils in order to enable them to acquire land and adapt it for letting as small holdings.

The county councils could not take up such loans, did not the Act further empower the Ministry for seven years after the passing of the Act to pay to the county councils any losses they had incurred in the provision of holdings under approved schemes. The loss each year consists of the excess of the loan charges over receipts for rent together with administrative expenses. Then on April 1 1926 a valuation is to be made of all the land acquired by county councils under the Small Holdings Act, and this valuation will be compared with the liabilities incurred by the council. The Ministry will then assume the responsibility of paying such portion of the loan charges due from the council as represented the excess of liabilities over the valuation. Finally the councils will be left as owners of the small holdings that have been set up with only such charges to meet as might reasonably be expected to be covered by the rents in the then conditions of the land market.

By the end of May 1921 some 34,000 applications for holdings had been received in England and Wales alone, 20,000 of which had been approved by the county councils; 277,000 ac. of land had been acquired, and 15,000 men had already been placed upon it. Slow as this progress may at first sight appear it has to be remembered that land cannot be acquired at short notice nor sitting tenants displaced except at the cost of burdening the scheme with impossible charges for compensation. The work of building and adaptation had also had to be carried out under the most difficult and burdensome conditions, at a time when both labour and materials of all kinds were abnormally deficient. In the great majority of cases the holding created was inevitably uneconomic, in the sense that the capital outlay on land, buildings and roads, fencing and other incidentals, cannot be repaid by the rents which can be paid under anything like existing conditions. The total cost of the scheme to the State, i.e. the expenditure that would have to be written off as not represented by the market value of the resulting holdings, can only be estimated, but seemed likely to amount to about 18,000,000. Undoubtedly the State accepted a very heavy financial responsibility in this scheme of land settlement for ex-service men, but it had to be taken as a partial repayment of the debt due from the State to the men who fought for it. As part of the national policy they were promised access to the land, and the conditions prevailing at the close of the war made it impossible to redeem that promise except at a loss.

**Education and Research.**—From the administrative point of view the chief advance effected during 1900–20 was the organization throughout the United Kingdom of a scheme of agricultural education and research. State assistance to agricultural education may be said to have begun with the Technical Instruction Act of 1889, but organized research remained practically unprovided for until the setting up of the Development Commission in 1908. The scheme then adopted was furthered by the allocation of fresh funds for the purpose after the end of the war, and most of the institutions contemplated were at work in 1921. The essential feature of the scheme is the provision of institutes, each dealing with a particular aspect of the subject and as a rule associated with a university possessing an agricultural department. The State exercises no direct control over the nature of the investigations conducted, other than the sanction accompanying its annual contribution, which is in the nature of a grant in aid. General policy is also reviewed at the meetings of a research council composed of the directors of the institutes and officials of the Government departments concerned. The staff of the research institutes are not civil servants but are engaged by the respective governing bodies; the State does, however, provide for a stated scale of salaries with increments and superannuation allowances. The annual expenditure on the scheme amounted to £140,000 for England and Wales for the year 1921–2, and to £5,400 for Scotland for the same period, but the Irish expenditure cannot so easily be differentiated from the other commitments of the Department of Agriculture.

The Experimental Station at Rothamsted, the oldest in the world, has been greatly enlarged and developed as the Institute of Research in problems of soil and plant nutrition, to which has recently been added a second institute dealing with plant pathology, embracing entomology, mycology and helminthology. At Cambridge is situated the main institute for research in animal nutrition, and a second station also exists in connexion with the university of Aberdeen. At Cambridge, also, investigations have been made dealing with animal-breeding from the genetic side and with problems of reproduction; and the plan was to draw all these threads together so as to make at Cambridge an institute dealing broadly with animal husbandry in all its aspects.

Research in dairying problems is provided for by an institute in connexion with the University College at Reading; and a second station was projected in 1921 in connexion with the Agricultural College at Glasgow. The plant-breeding station and institute proper are situated at Cambridge; a second station, specializing mainly on grasses, clovers and fodder crops appropriate to the moister climates of the west, is associated with the University College at Aberystwyth, and a third station was planned in 1921 in Scotland. The commercial development of the products of the plant-breeders is provided for by the National Institute of Agricultural Botany, which has also recently been set up at Cambridge largely by contributions from trade sources.

Research in fruit-growing problems is dealt with by an institute associated with the university of Bristol (Long Ashton) and a second station situated at East Malling in Kent, further sub-stations being in contemplation at Cambridge for the eastern counties fruit district and elsewhere. The Bristol centre also deals with cider-making and with the various processes of fruit preservation, to which end a small commercial factory is maintained at Chipping Camden.

The Imperial College of Science in London maintains an institute for work in problems of plant physiology, utilizing for its experimental cultures various institutions near London, such as Rothamsted, the Lea Valley Experimental Station which deals with glass-house problems, the East Malling Fruit Station, and the Experimental Gardens of the Royal Horticultural Society at Wisley. Mention should also be made of the John Innes Horticultural Institute at Merton, which under Mr. W. Bateson deals mainly with genetic problems, though this institution derives its income entirely from trust funds.

Schemes for dealing with research on problems of agricultural machinery and again with veterinary science were under consideration in 1921. As regards the latter subject the only institution mainly concerned with research is the laboratory maintained by the Ministry of Agriculture.

The complete scheme also provided an annual sum for grants in aid of particular investigations set on foot by individuals who might not be attached to a research institute, and again for postgraduate scholarships in order to ensure a supply of properly trained workers.

Higher instruction in agriculture is provided for by agricultural colleges, which as a rule are attached to one of the local universities and have a distinct regional responsibility as to the provision of information and technical advice to farmers occupying land in the area allocated to the college.

In Scotland three such colleges are attached to the universities of Aberdeen, Edinburgh and Glasgow; in England there are departments of agriculture attached to the universities of Durham (Newcastle), Leeds, Cambridge, Reading (Oxford), and in addition four residential agricultural colleges—the Harper Adams College at Newport, Salop; the South-Eastern Agricultural College at Wye, Kent; the Midland College at Sutton Bonington and the Seale Hayne College at Newton Abbot, Devon. In Wales the University Colleges of Bangor and Aberystwyth maintain similar agricultural departments. In Ireland higher instruction in agriculture is given at the Royal College of Science in Dublin and the Albert Agricultural College at Glasnevin, while there are professors of agriculture at the Queen's Universities of Cork and Belfast.

Intermediate education in agriculture is in Scotland organized by the agricultural colleges through extension lecturers attached to the various counties. In England and Wales the county councils are the responsible authorities, and the Ministry of Agriculture provides an agricultural organizer for each county and gives assistance towards the setting up of a farm institute, intended to give instruction by means of short courses for the sons of farmers, etc., who cannot leave the farm for the long periods demanded by the agricultural colleges. In Ireland intermediate instruction in agriculture is given at the Munster Institute, Cork, the Ulster Dairy School and the four regional agricultural stations at Athenry, Ballyhaise, Clonakilty and Strabane.

Steady progress has been made in all parts of the United Kingdom in the schemes for the improvement of live stock, by the dissemination among the smaller farmers of improved sires. In Ireland, where the scheme came into operation in 1911, premiums, to which both the Department and the local authorities contribute, are given towards the purchase of approved bulls and other sires, and the success of the scheme is manifest in the improvement effected in the quality of the store cattle exported for fattening to Great Britain. In England and Wales farmers are encouraged to form societies for the purchase of a bull or the hire of a stallion, and a grant is made towards the cost of the sire, which in the case of a bull may not exceed  $\frac{2}{3}$  or one-third of its cost. The work of forming societies for recording the milk yield of the cows of the members has been vigorously prosecuted, and the growth of the movement is shown by the fact that 637 cows obtained certificates in 1915 and 16,211 in 1921. The high prices obtained for recorded cows and their progeny show the value that farmers attach to milk records.

### III. THE WAR PERIOD

For a long time after the declaration of war no special effort was made in the United Kingdom to develop agriculture and increase production of food. A measure to prevent the slaughtering of calves and pregnant animals was passed in 1914, but no other legislative action was taken until the close of 1916. Proposals which had been made, such as those of the Milner Committee, to guarantee a price for wheat or to give other bounties on production, were turned down on the broad principle that any interference with the free play of the market would impair the confidence of the trader and reduce importation to a greater degree than the increase in production. In 1915 in response to the general feeling farmers had increased their acreage of wheat by 430,000 ac. and of oats by 200,000, but this increase had chiefly been attained at the expense of the barley crop, for there had been no increase in the total extent of land under the plough. In 1916, however, the wheat area went back by 280,000 ac., and a low yield per acre was obtained. The potato crop also was much below average. It may be noted here that, speaking generally, except in the magnificent harvest of 1914, the seasons during the World War were very adverse to arable cultivation, being characterized by wet seeding-times and harvests, with spring droughts. It was not until 1917–8 that there was a favourable autumn and spring for sowing, but that promise was belied by a disastrous harvest-time for all the western and northern parts of the kingdom, with rains so heavy and protracted that no inconsiderable proportion of the corn crops were never harvested.

**Intensified Production.**—It was not until the close of 1916 that any action was taken to stimulate production. By that time the effects of the enemy interference with the free play of the market and the indifferent output began to be apparent in rapidly rising prices for all the prime food products—corn, potatoes, meat and milk. At the same time the withdrawal of labour from agriculture was bringing about a still further diminution in the area under wheat, of which at the close of 1916 it was estimated that 15% less had been sown than at the corresponding season in the preceding year. The appointment of a Royal Commission on

Wheat Supplies, which assumed complete control of the purchases of wheat and the operations of the milling trade, was followed by the appointment of a Food Controller and a promise in Dec. of certain guaranteed prices for wheat, oats and potatoes. At this time Rowland Prothero (afterwards Lord Ernle) had become President of the Board of Agriculture, and he proceeded to set up a Food Production Department which would take charge of a national effort to obtain more food from the land. To this department came as chief Sir Arthur Lee (afterwards Lord Lee of Fareham).

The policy adopted aimed at obtaining an increased acreage of arable land and also a proportion of wheat and other bread corn as possible. Success depended upon the co-operation of the farmers, upon securing additional labour and upon assisting the farmer to obtain supplies of all kinds—horses, tractors, seeds and manures.

The first step was to set up War Agricultural Committees in each of the counties of England, Wales and Scotland; in Ireland the existing statutory County Council Committees on Agriculture were available for the same purpose. In England smaller executive committees were afterwards appointed, to whom were entrusted in the main the special powers which had been conferred by D.O.R.A. on the Board of Agriculture. District committees, and even in some cases parish committees, were further appointed. The staffs required for the executive committees were made up from the county council staffs and officers of the Land Valuation Department and Inland Revenue, while district commissioners appointed by the central department for small groups of two or more counties served to bind the whole organization.

As it was already Jan. 1917 before the Food Production Department was set up, it was impossible to effect much increase in the crops of that year, and in practically all cases it was obtained by voluntary response to the appeal for greater production. In England and Wales a further 286,000 ac. were put under the plough; the increase in wheat was 50,000 ac., in oats 616,000 ac. and in potatoes 220,000 acres. Scotland, having suffered less loss of arable land in the generation prior to the war, had smaller opportunities for reconversion from grass into arable, but added some 50,000 ac. to the plough land. In Ireland, however, the greatest extension was possible because of the much smaller draft that had been made on its man-power. An Order in Council was made requiring all Irish occupiers of more than 10 ac. to add 10% to their area under tillage, except in cases where the arable already amounted to 50% of the total cultivable area of the farm, and this resulted in an addition of nearly 650,000 ac. to the plough land of that country.

While this was going on during the spring of 1917 the county executive committees with the help of their district committees carried out a survey from farm to farm which revealed in all too many cases into what a state of neglect the land had been allowed to fall. Notices were served calling for improved cultivation, and in the worst cases the tenancies were determined, the executive committees either approving a new tenant, or taking the land under their own control. The central department framed a programme for 1918 which provided for the ploughing-up in England and Wales of 2,000,000 ac. of permanent grass as compared with 1916, and in Scotland of 350,000 acres. A quota was fixed for each county, based upon such considerations as the area which had been converted from arable into grass land since 1872, the existing proportion of arable in the county, the labour still upon the land, etc. Each county in its turn divided its quota among districts and eventually among the parishes and the individual farms, orders to plough certain fields being served upon the occupiers. These "ploughing orders" in many cases excited violent opposition, and sustained attacks were made upon the Department on the specious plea that ignorant officials were ordering grass land, which was providing meat and milk, to be converted into plough land which would yield nothing. Time considerations alone permitted of no appeal from the order of the committees, who had perhaps acted in some cases on the principle of making every man do a share proportional to his

acreage without consideration of the character of the land. But the mistakes made, if one is to judge by the mass of the results afterwards realized upon the broken-up land, affected but a small proportion of the land ordered to be put under the plough. The opposition both of occupiers and owners to the plough policy must be set down to the grass-land tradition, which the great depression of 1880-1900 had so firmly impressed on English agriculture.

None the less the programme was adhered to, and, aided by favourable weather in the winter and spring of 1917-8, a remarkable increase in the cultivated area was achieved. The disturbed state of Ireland prevented the realization of the plans which had been formed for a still further increase of 5% in the cultivated area. The tables show what was actually obtained in each of the three countries.

England and Wales

	1914	1916	1917	1918
	ac.	ac.	ac.	ac.
Arable land . . . . .	10,998,251	11,051,101	11,246,106	12,398,610
Wheat . . . . .	1,807,498	1,912,208	1,918,485	2,556,661
Barley . . . . .	1,504,771	1,332,076	1,459,706	1,500,609
Oats . . . . .	1,929,626	2,084,674	2,258,909	2,780,063
Potatoes . . . . .	461,621	427,948	507,987	633,832
All crops other than temporary grasses and fallow . . . . .	8,276,166	8,038,993	8,301,263	9,894,695

Scotland

	1914	1916	1917	1918
	ac.	ac.	ac.	ac.
Arable land . . . . .	3,495,487	3,083,741	3,360,862	3,433,495
Wheat . . . . .	60,521	63,083	60,931	79,662
Barley . . . . .	194,109	169,739	159,135	152,815
Oats . . . . .	919,580	990,589	1,041,343	1,243,823
Potatoes . . . . .	152,318	130,119	147,717	169,497
All crops other than temporary grasses and fallow . . . . .	1,896,350	1,815,217	1,866,575	2,094,376

Ireland

	1914	1916	1917	1918
	ac.	ac.	ac.	ac.
Arable land . . . . .	5,027,082	5,050,234	5,046,008	5,270,615
Wheat . . . . .	36,913	76,438	124,082	157,366
Barley . . . . .	172,289	190,063	177,135	184,712
Oats . . . . .	1,628,758	1,071,593	1,463,737	1,579,537
Potatoes . . . . .	583,069	586,308	709,263	701,847
All crops other than temporary grasses and fallow . . . . .	3,377,752	2,400,328	3,037,869	3,239,495

United Kingdom

	1914	1916	1917	1918
	ac.	ac.	ac.	ac.
Arable land . . . . .	19,320,823	19,408,076	19,663,676	21,127,750
Wheat . . . . .	1,904,932	2,031,729	2,103,498	2,793,049
Barley . . . . .	1,871,169	1,651,878	1,796,068	1,838,356
Oats . . . . .	3,877,964	4,146,836	4,763,989	5,603,423
Potatoes . . . . .	1,197,068	1,144,375	1,364,967	1,505,174
All crops other than temporary grasses and fallow . . . . .	12,410,268	12,254,450	13,295,707	15,228,366

Speaking roughly, about 40% more grain was produced in 1918 than in 1916, and if the potato crop is also taken into account the 1918 crops represent a saving in tonnage (and shipping was the limiting factor in the prosecution of the war at that time) of 2,600,000 tons. Results would have been even better had it not been for the disastrous harvest weather, which caused the total loss of something like 5% of the grain crop, and rendered even more unfit for any other purpose than cattle-feeding. The occurrence of so continuous a succession of heavy rains was naturally regarded by the opponents of "ploughing up" as a justification of their adhesion to grass. It did indeed put an end to the plans which had been made for a further extension of the arable area in 1919. Work on most farms had fallen badly into arrears, and land had become foul and weedy, so that it seemed preferable to concentrate the available labour on the existing



tillage land rather than to attempt to increase its area in the face of the general opposition of the agricultural community.

**Labour Supply.**—Turning now to the means by which this increased production was realized in war-time, the prime difficulty experienced was the lack of labour. Grass land had often been described as a reserve of fertility that in case of need could be converted into crops, but this view had ignored the facts that laying down to grass is accompanied by the permanent loss of men and horses, implements and even buildings. When the need comes tillage cannot be resumed at pleasure; the men and machinery are no longer there. In Jan. 1917, when the food production campaign began, the 800,000 men employed in agriculture in 1914 had fallen to 562,000, and as about 180,000 of these were of military age and fresh drafts were urgently needed for the army, some new sources of labour had to be tapped. The operations of voluntary recruiting, and the action of local tribunals in granting exemptions, had produced very unequal results; the eastern and home counties, for example, had parted with a much larger proportion of their men to the colours. For a time in 1917 the calling-up of men from farms was suspended, but the spring offensive of 1918 resulted in a fresh call for 30,000 Grade 1 men from agriculture, 22,600 being actually called up. Meantime, however, the War Office rendered great assistance by the release of men on home service for short periods when the call for labour was greatest. In the spring of 1917, 21,000 ploughmen were lent for two months, together with about an equal number of other men with some experience of the land or of horses, and these men did much to render possible the first increase of tillage land. Though 18,000 of these men in Category A had to be returned to the army in May 1917, almost an equal number of men on home service were released for the harvest of that year. Other men were furnished by the military authorities during the autumn and winter, until in the spring of 1918 there were about 62,000 men working upon the land though nominally engaged on military service.

Assistance was also obtained from enemy prisoners-of-war. Early in 1918 prisoners at work in France, who were skilled ploughmen and had other agricultural experience, were brought across and established in camps of from 25 to 40 for work upon farms throughout England. The first prejudice against the employment of these men was soon dissipated as their skill and willingness to work became apparent, and eventually a certain number were even allowed to be housed upon farms without guards. As a rule these men were employed upon the Department's ploughing contracts or drainage operations, or other work that would absorb a gang of men and minimize the number of guards required. In the great majority of cases the German prisoners did excellent work and even came to be preferred by farmers to the local labour that had been left to them. Nor did any trouble arise over discipline; the tale is told of the guard who was brought back to camp helplessly drunk, supported by two of his prisoners, with a third carrying his rifle.

Various attempts were made to recruit civilian labour permanently and for special harvesting operations, but with little success. The only valuable recruits that were obtained were the public-school boys, some 4,500 to 5,000 of whom were formed into camps for the harvest and did service that was much appreciated, and again the camps of Boy Scouts, who in their turn did first-rate work for the farmers with whom their camp was placed. A certain number of "conscientious objectors" were told off for agricultural work, but the feeling against them in most rural districts was too strong to permit of their employment, and such of them as were engaged in camps proved of little use.

The greatest part of the accessory labour required in order to carry out the agricultural programme of 1917 and 1918, was provided by women. The supply was organized by the Women's War Agricultural Committee in the counties and by the Women's Branch of the Food Production Department. In the first place the employment for part or whole time of the women resident in the villages, who, in England at any rate, had largely ceased to work on the land, was revived, with the result that over a quarter of a million were at work in 1918 as compared with less

than 100,000 before the war. Some assistance was given to these workers by the supply of boots and other outfit for farm work. Considerable camps were also formed of college students for temporary labour in the harvests of 1917 and 1918, and these women did excellent service in flax-pulling and other seasonal operations. But the chief effort was to provide a mobile force of women's labour from sources that did not usually furnish land workers, and at the beginning of 1917 the Women's Land Army was organized. The recruits were very carefully examined for fitness; indeed, something like 75% of the first 47,000 who volunteered were rejected, though by 1918 a considerable improvement in the material coming forward became manifest. Most of the women had to be trained, even if only for a few weeks, and in addition to the facilities provided by certain agricultural colleges and farm schools, over 600 special training centres were established. A minimum wage was laid down, at first 18s. and later 20s. a week, and in addition an outfit of the necessary clothes was provided. Depots had also to be established where the women who were waiting for employment or temporarily unengaged could be housed, and the women were eventually distributed between farm work, the Forage Department of the War Office and the Timber Supply Department.

At first considerable prejudice had to be overcome on the part of farmers, and again great difficulties were experienced in assuring proper accommodation for the women on the farms, but by the winter of 1917-8 some 7,000 were at work, and the number increased to 16,000 in the harvest of 1918, until the workmanlike costume of the landwomen, with their brooches and smock, became a familiar feature of all country life in England and Wales. On the whole these women proved of most service as milkers and in charge of stock and horses, for which many of them showed a special aptitude. Others again developed into very efficient drivers of motor tractors.

After the war and the return of the agricultural labourers on service, the demand for whole-time women's labour to a large extent disappeared. Moreover, a large proportion of the landwomen, especially the educated women, had taken on this kind of work for patriotic reasons, and had no call to the life of an agricultural labourer, so that the Women's Land Army was disbanded in 1919 and very few of the workers so recruited remained in 1921 upon the land. Undoubtedly, however, a certain number of women whose circumstances permitted were led to take up farming as a profession, and the whole movement, over and above the indispensable work it actually accomplished at a critical time, led to the diffusion through the community of a much better understanding of agriculture and rural life.

**Tractors.**—After labour, the provision of implements and especially of tractors proved the main difficulty of the Food Production Department. At the outset, in the early spring of 1917, with the immense urgency of getting land ploughed forthwith for the harvest of that year, it was necessary to buy every and any tractor available. Something under 500 were at work in three months, together with about an equal number of privately-owned tractors which were controlled by the Department in order to get a maximum of work out of them. The Department engaged the ploughmen and operated the tractors, a charge being made to the farmers of 15s. to 20s. per acre for ploughing and half that rate for cultivating. Naturally the service did not pay its way; many of the tractors were far from efficient, and with the limited training that had been possible the drivers were, at first unable to get a good average acreage worked per day. As experience of the various types of tractors accumulated it was decided to concentrate the main effort on the production of the Ford tractor, the specifications of which were placed by Henry Ford at the disposal of the Government. It was found possible neither to manufacture any of the British types nor to undertake the production of the Ford tractor in England, so entirely had British engineering works been turned over to the output of war material. Instead, orders were placed with Mr. Ford, and delivery began early in 1918. By the end of the year the Department was operating 4,900 tractors, despite the withdrawal of the large numbers of earlier types, and a further 3,000



had been sold to farmers from the supplies ordered by the Department. In the year 1918 650,000 ac. were ploughed and 580,000 ac. were cultivated by the Department's tractors, and in many districts where the means for arable farming had run low the ploughing programme could have been carried out in no other way. Nor was it the ploughing only that was forwarded; the difficult harvest of 1918 was in many cases only won through the capacity of the tractor to get the binders over a large acreage in a short time. Great as were the expenses attending the tractor programme, it was justified not only by the immediate results but by the education it afforded the British farmer in the use and value of mechanical traction, an education which might have required a generation under peace conditions.

In addition to tractors, the Department obtained sanction for the purchase of 30,000 horses, and formed gangs of teams to work under the district committees in parts of the country where the programme of ploughing-up grass land was beyond the strength of the farmers themselves. The numbers purchased were limited by the skilled ploughmen available to go with them, but something like 10,000 horses were working under the orders of the Department at the end of 1918, and an equal number had been lent to farmers. The steam-ploughing tackle existing in the country was also organized, and the owners engaged to keep their machines at work not only through the winter but also overtime and on Sundays. Facilities were given for the manufacture of further sets of tackle, until there were 90 more at work by the autumn of 1918. A very great share in the programme of extra cultivation was accomplished by the energy of the steam-tackle owners. Indeed, between their first meeting in March 1917 and the end of that year over 1,000,000 ac. of ploughing and cultivation had been accomplished, and 23,000 ac. had been mole-drailed. The Department also purchased in America, and loaned or sold to farmers, large numbers of other implements, the manufacture of which in Great Britain had been to a large extent suspended in favour of munitions. Something like 5,000 binders, as many harrows and proportional numbers of other implements, including nearly 500 threshing-machines, were thus obtained by the Department and disposed of to farmers.

**Fertilisers.**—The effect of two and a half years of war and the increasing shortage of tonnage had begun to be manifest early in 1917 in a very marked disorganization of all the sources of supplies needed by the farmers—fertilizers, feeding-stuffs, seeds and minor but still essential articles like sulphate of copper and binder twine. The Food Production Department took charge, and achieved remarkable success in both extending supplies and regulating distribution to ensure equality of treatment and the saving of transport. In nearly all cases the organization was carried out through the trade concerned, the members of which formed associations and agreed to pool their resources and limit prices. Practically the only nitrogenous fertilizer available was sulphate of ammonia; shipping was no longer available from Chile for nitrate of soda, of which an earlier large Government purchase could not be moved and had eventually to be resold. Prior to the war the production of sulphate of ammonia in the United Kingdom had exceeded 400,000 tons per annum, of which about 70% was exported, while the home consumption for agriculture did not reach 70,000 tons, and indeed was not more than 78,000 tons in 1916. The propaganda and distribution scheme of the Food Production Department secured the use of as much as 234,000 tons in the year June 1917–June 1918. Basic slag was similarly dealt with, grinding facilities were obtained, and the consumption was increased by something like 200,000 tons. Owing to the shortage of shipping it was impossible to maintain supplies of phosphate rock for the manufacture of superphosphate, but some alleviation of the scarcity was obtained by the diversion of shipping to North Africa, and over 750,000 tons of superphosphate were distributed for the year ending June 1918.

Thus the work of the Food Production Department did succeed in putting at the disposal of farmers in the harvest of 1918 a substantially greater amount of fertilizers than they had been in the habit of consuming prior to the war, and this at a time when

the sources were diminishing had no governmental stimulus been applied and when most of the production would have gone for export with the relatively enormous prices that were ruling outside the United Kingdom. There has been but little recognition of the amount the British farmer gained from the control over fertilizers that was exercised from 1917 onwards.

Little need be said about the steps that were taken to ensure the supply of seeds and other articles of agricultural consumption. The most striking result was the way in which the great dearth of seed potatoes from the 1917 crop was met. More than 15,000 tons of seed potatoes were distributed in England and Wales, and, above all, the newly-formed allotments that had been so eagerly taken up in that year were furnished with the seed potatoes they needed. The opportunity was taken early in 1917 to enforce a declaration of germinating capacity and purity of all seeds sold; and this action, necessitated at the time by the scarcity of material and the resulting commercial temptation to sell inferior seed, so commended itself both to farmers and the trade that it was embodied in a permanent fashion in the Seeds Act of 1920.

**Allotments.**—In no respects perhaps was the Food Production Department more successful in helping out supplies than in the stimulus and assistance it gave to the creation of allotment gardens, particularly in urban centres. The powers conferred upon the Department by D.O.R.A., which were delegated to town and urban district councils, enabled them to take possession of any unoccupied land for the purpose of letting it as allotments, and even of cultivated land with the sanction of the Agricultural Executive Committee. These powers were freely exercised, and perhaps an equal amount of land was made available for allotments by voluntary agreement. Because of these private agreements it will never be known exactly how many allotments were provided during the war period, but over 250,000 were added in England and Wales under the D.O.R.A. powers alone; and so rapid was the further growth that it was estimated in 1928 that the total number of allotments had been more than doubled. On the outskirts of all large towns the new movement was very much in evidence in the spring of 1917; unoccupied land of all kinds, building plots, waste land awaiting development, portions of commons, even parks and recreation grounds, were being divided up into plots of a sixteenth of an acre and hastily prepared for growing vegetables. It was often late in the season before the work began, particularly for heavy land such as the clays round London, but fortunately the season proved favourable and good results were obtained for the zeal and energy which had been put into the cultivation of what was often very unpromising material. The Food Production Department assisted in the supply of seed potatoes and other supplies; advice and instruction were organised in conjunction with the Royal Horticultural Society, which enrolled the professional gardeners everywhere into a panel of voluntary instructors. It was estimated that by 1918 the number of allotments had increased in England and Wales from something like 800,000 to over 1,200,000, and the increase was continued after the Armistice. The number relative to the population varied considerably, but in and about Leicester there was an allotment to every three households.

The benefit of the allotment movement to the community is difficult to overestimate. There was in the first place the actual addition in the food supply, which in England and Wales alone was set at 800,000 tons of food in 1918. This home-grown supply without doubt helped to steady prices in 1917. Again, the growth of fresh vegetables by urban populations, who under the prevailing conditions would have had some difficulty in buying them, contributed a very valuable factor in a war-time dietary. The development of allotments did contribute to keep down the growth of deficiency diseases like scurvy and probably of tuberculosis, to which the food conditions of 1917–8 were favourable. Lastly, very many people obtained a considerable relief from the war strain by the physical exercise in the open air and the new interests developed by their allotments. To many people the war-time allotments revealed a deep-seated pleasure in the cultivation of the land, which had been obscured to them by

residence in a town, and the strength of this feeling was made manifest by the widespread movement that grew up after the war for the retention and extension of the allotment gardens.

Of course, the close of the war necessarily led to the displacement of many of the allotments which had been formed on land that could only be temporarily allocated for the purpose. Much of it had only been handed over on private agreements and was resumed for building or other industrial purposes. Recreation grounds and park lands could not be permanently alienated from the enjoyment of the general public. Even land which had been occupied under the D.O.R.A. powers of the Board, and of which possession could be retained until March 23 1923, had often to be given up because its retention would have involved enormous claims for compensation when the land was immediately required for building purposes. Widespread as was the demand for security of tenure in allotments it was impracticable either to gratify it now, or to repair the want of foresight when the great towns were growing, by making allotments at the expense of the community on land which had already acquired a building value of £1,000 an acre or upwards. It might still be possible to provide for allotments on such land while it was vacant and awaiting development, but only on condition that the occupiers would have to be prepared to move on at comparatively short notice when building became imminent. Many authorities in 1921 were exercising with considerable forethought their powers to acquire land for allotments, and were acquiring land conveniently accessible outside the zone of immediate development. Round many cities and towns a belt of allotment cultivation could be seen to be extending, though the cultivators might actually live at some considerable distance in the thickly populated inner area.

Incidentally the Agriculture Act of 1920 gives an allotment-holder compensation for disturbance on similar lines to that enjoyed by occupiers of larger buildings.

The growth of the allotment movement may be measured from a very full inquiry that was made of the numbers at the end of 1920. According to an early return in 1890 there were then 448,586 allotments in England and Wales of under one acre, to which should be added certain railway allotments estimated as 39,115 in 1886.

At the end of 1920 the numbers in England and Wales were as follows:

	No. of allotment holders	Acres
Land managed by county councils under Act of 1919	329,471	46,963
Land entered upon by councils under D.O.R.A.	198,299	14,369
Land occupied by councils and used temporarily under D.O.R.A.	56,456	4,141
Other land used as allotment	598,157	95,754
<b>Totals</b>	<b>1,182,383</b>	<b>161,227</b>

Owing to the fact that in six cases the allotment land was let to associations of allotment-holders, the gross total of holders should be increased to about 1,330,000. It should be noted that one-half in numbers and considerably more than half in acreage of the allotments in England and Wales were still provided in 1921 by private owners.

**Control of Agricultural Prices.**—The pressure of the war and the increasing difficulty in obtaining supplies necessitated a resort to the fixing of prices for agricultural commodities, which materially affected the business of British farmers during the critical years from the beginning of 1917. The Food Controller was appointed in Dec. 1916, and the Act under which he was appointed gave him very complete powers to fix the prices of commodities and to take over stocks, to control distribution and otherwise deal with all articles of food produced within or entering the country.

As might be expected, considerable discussion and differences of opinion arose as to the methods to be adopted in dealing with agricultural produce. From the cruelest point of view the Food Controller might be taken as the agent of the vast majority of consumers, anxious therefore to reduce prices, whereas the

Departments of Agriculture would be regarded as the guardians of the interests of the agriculturists. Such an opposition of interests was, however, rarely allowed consciously to weigh. The divergences of opinion grew from the fact that the Agricultural Departments were more seized with the necessity of increasing production, and apprehensive of the way in which restrictions upon price might so interfere with the business of the farmer as to limit the total output of food. It may be useful to put on record some of the results of the control and the effect they had upon the course of production.

During the years 1917-9 control was exercised over the prices of all the main articles of agricultural produce—grain, meat, milk, cheese and butter, potatoes, eggs, fruit, certain vegetables, wool and hay, though in the two latter cases the control was exercised by the War Office and not the Food Controller. Two ends have to be satisfied in the control of prices of agricultural produce. Primarily the public have to be protected from excessive rises of price, due primarily to the scarcity and then to the speculation and repeated dealings amongst the middlemen that inevitably follow. The farmer himself, the prime producer, is rarely in a position to take advantage of the public need and, in the current slang, "to fifteen." The conditions of the farmer's business are such that he is waiting on the price that is offered to him in the open market. Most of his output consists of perishable materials which must be sold forthwith, and he is rarely united into associations that are capable of exercising any pressure to refuse to sell below an agreed price. The rapid enhancement of prices that follows scarcity is as a rule the work of the dealers between the producer and the consumer, and the farmer is but a passive recipient of the share that accrues to him through the competition of dealers for his produce.

The second end to be attained in price control is the encouragement of production. It is possible to fix a price in the interests of the consumer which may be regarded as leaving a fair margin of profit to the producer, but which is followed almost immediately by a restriction in supply. High prices are of course an evil from the point of view of the consumer, but in times of scarcity it is more important to get the food in quantity than to get it cheap. It becomes necessary, therefore, to fix such a level of prices as will encourage the producer to make a special effort to increase his output, and to this end it is never possible to base the price upon the average cost of production of the article. It is necessary to stimulate the production of the poorer farmers, whose skill may be inadequate or who are working under comparatively unfavourable conditions. As a consequence it follows that the prices will be such as give excessive profits to the more favourably situated producers. This is specially marked in dealing with agriculture—an industry which in the main is carried on by individuals working upon a comparatively small scale, an industry in which the processes are not standardized and for which accounts showing the actual cost of production are very rarely available.

Considerable feeling was at times engendered against the farmers in Great Britain on the ground that they were making very large profits out of the public need and the restriction of supplies, but looking at the question broadly, these excessive profits accrue inevitably to the men who by their skill or their situation were capable of comparatively cheap production.

From time to time attempts were made to establish systems of differential prices, according to districts. This was tried, for example, with milk, on the ground that the south-western counties could, as a rule, produce milk at a lower price than the mass of the country. Again, in 1918 differential potato prices were established by districts, according as they were regarded as adapted or otherwise to potato-growing on a large scale. Speaking generally, these differential prices proved to be comparatively ineffective and were the cause of great discontent and opposition amongst the producers. The main difficulty lies in the definition of districts within which the conditions of production are equal. County boundaries do not represent uniform conditions of soil and climate. The object could only be rightly attained by the scheduling of individual farmers into different classes and that is administratively impossible.

As a rule, the method of control adopted was to fix a maximum price beyond which the article must not be sold, and to enforce this maximum price by the action of inspectors. It was found in all cases of real scarcity that the maximum price became a minimum, and that the control amounted to the fixing of a flat rate of price for the article all over the country. Maximum prices having been fixed, there are then two alternatives: the Government may become the sole buyer of the commodity, or it may still leave distribution to the ordinary channels. It was found by experience that the Government can only become the sole buyer when it also controls the consumption of the article. The main examples of this type of action during the war period were wool and wheat. In the case of wool the Government held the whole stocks, both of foreign and home-grown wool, and made its allocation from these stocks to the manufacturers for defined purposes. In the case of wheat the Government assumed control of all the flour-mills and instructed them to accept delivery of the farmers' wheat at the fixed prices.

Where the processes of manufacture and distribution are not so simple, as in the case of wheat and wool, the method of making the Government the sole buyer of the output resulted in excessive administrative difficulties. An example is furnished by the potato crop of 1918, which on Nov. 1 was taken over by the Ministry of Food. The difficulties were accentuated by the fact that the crop was a large one, rather more than the demand would normally call for, and that it was not as sound as usual, so that in many cases the whole or part of the crop perished in the farmers' clamps before it could be distributed. Under normal conditions the farmer who has potatoes of inferior keeping powers makes a sacrifice in order to get them away rapidly. He also looks the crop over from time to time and rejects potatoes that are becoming diseased and therefore dangerous to the bulk of the crop. Once, however, the crop had passed into the Government's hands, the farmer naturally ceased to exercise the same care in handling it. The result in this case was a dispute as to the responsibility for the losses that occurred. The Ministry on the one hand alleged that the losses had been due to the initial unsoundness of the crop, for which the farmer must bear the responsibility. The farmer, on the other hand, alleged that he remained in control and he could have disposed of the crop and that the losses were due to the Government's delay in moving it to the consumer. When the Government attempts to replace by a new official organization the intricate machine which custom has built up for the distribution of any general article of consumption, the result is confusion and increased cost. The "trade" machine may be intricate and illogical, but it has been in the habit of working and it has been shorn of waste by competition.

If the Government does not constitute itself the sole buyer of the production, it yet follows that it must assume the control of distribution as well as of prices. Under normal conditions it is only by the offer of a price above the average that any locality distant from the source of supply, or otherwise unfavourably situated, can attract to itself the supplies that it needs. With a flat rate of price the producers will endeavour to sell as near home as possible. The near localities would thus become abundantly or even over-supplied, while the distant localities would have to go without. Not only must the Government control the distribution, but also it must fix prices all along the scale between the producer and the consumer. It is not sufficient to fix retail prices only to the consumer, nor, at the other end of the scale, producers' prices only. It was, therefore, found in practice necessary to fix both the price to the consumer and to the producer, and also the percentage that could be taken by each middleman in handling the commodity. This inevitably resulted in an increased margin between the prime cost obtained by the producer and the price finally paid by the consumer, because all the intermediaries between the producer and the consumer established their claim to a commission, whereas in practice some or other of them are generally cut out by competition, or have to take a lower toll than that for which they are able to make out a case.

Speaking generally, when a Government has to make a bargain, either with producers about price or with the members of a trade for their services, it fails to get good terms. The accounts of the weaker producers or agents are always put forward, and the price is determined according to their needs and their expenditure. Moreover, the parties always deal in terms of round pennies and round shillings, whereas in normal working profit and loss is determined by eighths or sixteenths one way or other.

The main difficulty, however, that besets the control of agricultural prices arises from the alternative nature of the farmer's business. As a rule he has more than one way of disposing of his produce. For example, he may find it more profitable to turn his wheat into food for hens and sell eggs or poultry than to sell the wheat itself. He has the alternative of selling his barley crop or grinding it into meal and feeding pigs with it. His milk can be sold as such or converted into butter, cheese or veal, according to which offers the greatest prospect of profit. It therefore follows that for no article of agricultural produce can the price be fixed without reference to the prices ruling for other products which may from the farmer's point of view be alternative. The farmer may even—though this is more difficult and acts more slowly—vary his method of dealing with the land. For example, at the time when the land was most in need of corn production and the Food Production Department was engaged upon a strenuous campaign to extend the area of arable cultivation, the farmer was able to obtain much greater profits from the production of meat and milk on grass land than from corn upon arable land, because a proper parity had not been established between corn and meat. In fact, the fixing of prices of agricultural produce should be preceded by a scientific examination of all alternative conversions of one product into another which are possible to the farmer. It is possible to construct a scale of parity which shall show the price relationship of such diverse articles as hay, corn, meat, milk and milk products. Prices should then be fixed in accordance with this scale of parity, weighting those articles which it is desired to produce in the general interests of the community by giving them a rather better price than the scale of parity would indicate.

The neglect of this principle led to many difficulties and much discontent in particular cases. For example, in 1918 the prices at which the British farmer was called upon to sell his wheat, oats and barley were a good deal below the prices at which he could buy other

articles of cattle-food on which to feed his stock. The farmer was forbidden to use wheat and barley for stock if it was sound and fit for milling. On the other hand he could buy no feeding-stuffs so cheap, and corn which had been damaged in harvesting or was otherwise unfit for milling purposes was more valuable to the farmer as stock food than the price fixed for sound corn. Inevitably this state of things led both to carelessness in harvesting and storing corn and to a certain amount of evasion of the order forbidding the use of sound corn for feeding stock. That the extent of the evasion was not greater was due to the general state of public opinion at the time, but a more careful consideration of the question of parity of prices would have removed the temptation and resulted in more corn being available for the general public. Another example may be seen in the case of butter. It takes from 2½ to 3 gallons of milk to make a pound of butter, yet for various reasons at the time when milk was selling at 2s. a gallon or even higher prices, the price of butter was fixed at 2s. 6d. per pound. The result was the almost complete disappearance of home-made butter from the market.

A still more noteworthy example of the difficulties arising from price fixation and the alternative use of products is supplied by the later dealings with milk. Prices of milk were fixed at six monthly intervals from 1917 onwards and rose steadily from year to year as the shortage of labour and the cost of feeding-stuffs increased. The prices fixed were without doubt remunerative to the great majority of dairy farmers, as can be judged from the expansion of cow-keeping and the abnormal rise in the price of dairy cows. Eventually when winter prices were fixed in the autumn of 1919 the public definitely revolted and the demand for milk declined all over the country. The season was also such as to produce an unexpected abundance of milk. All wholesale milk-supply businesses must possess some alternative means of utilizing milk and generally adopt cheese-making in order to deal with their occasional surpluses. The Ministry of Food, in its anxiety to encourage winter milk production and yet unable to fix a cheese price in parity with the price of milk, had adopted the expedient of offering an allowance to wholesalers for all cheese made in the autumn months. With the refusal of the public to buy milk freely this cheese grew into quantities altogether beyond anticipation, at the same time the allowance did not make up for the wholesalers' losses on the contracts at maximum prices they had made with farmers. The situation became impossible, and eventually early in 1920 control had to be abandoned, with the result of a general breaking of contracts and a sharp fall in price. A system of control of prices which will work well and secure a uniform distribution during a period of scarcity lacks any power of adjusting itself to the other situation, which is always liable to arise, of supply outrunning demand. The public sooner or later revolts at the price, whereupon the producer demands from the Government a market as well as a price.

The establishment of fixed prices, by obliterating the variations which under normal conditions meet variations in quality, causes the deterioration of the general average of quality. Various examples were seen of this operation of a flat price. For example, in 1919 the finest grade of Cox's orange pippin apples had to be sold at prices below that which they normally obtained in pre-war times, because the maximum price for dessert apples, high as it was in comparison to pre-war prices, still made no allowance for the choicest grades. Nor is it possible under such conditions to remove these special articles from the control. If there are two prices the retailer immediately removes the whole of his wares into the higher category and the consumer is faced with the alternative of paying the higher price or going without.

Another example of the effect of the flat rate of price might be seen in the general deterioration of quality of all kinds of cheese made during the war years. The producer could get a higher price for fine quality, and since storage and therefore the development of flavour is inevitably accompanied by loss of weight, the cheese was sold as cheaply as possible without regard to its quality. Again, the fixing of a flat rate of price for mutton and lamb of all kinds resulted in a great diminution in the number of sheep kept upon the arable land, like the South Downs and the Hampshire Downs. These flocks derive their returns chiefly from the sale of lamb at comparatively high prices, but when the extra price for lamb was unobtainable with their more expensive methods of production they became unprofitable. Between 1913 and 1919 the numbers of sheep in England and Wales taken as a whole declined by 11·7%, but the flocks in predominantly arable counties like Hampshire, Wilts and West Sussex lost about 40% of their sheep. The decline in sheep fell in the main upon the arable land sheep because they could no longer obtain the normal differential prices for their output.

One general conclusion may be drawn from the operations of controls during the later years of the war, a conclusion strengthened by a consideration of the parallel events in Germany and France where the pressure was greater—that State action has very little power to compel agriculturists to conduct their businesses along lines contrary to the interests or traditions of the farmers themselves.

For example, numerous orders and regulations were promulgated from 1914 onwards forbidding the slaughter of calves, even

to the extent of closing the markets to the sale of calves for slaughter and of forbidding the sale of veal. Though the measures had the approval of all the farmers' organizations they were systematically evaded and were wholly without effect in checking the increasing slaughter of calves. Again, the orders that forbade the use of barley and wheat for feeding stock in 1917 and 1918 were not observed whenever the farmer was in any real difficulty about getting food for animals. No farmer will see live stock starve and the agricultural conscience was salved by a consideration of the extraordinary mixtures of waste material that were being purveyed as cattle-food at higher prices than the farmer was allowed to receive for his sound wheat and barley. Again, in the rationing of the self-producer, the regulations declaring that a farmer might only retain so many of the pigs he killed at home, or so much of the poultry, milk, butter or cheese he produced, were simply ignored. It is impossible to enforce such regulations except by a system of espionage and inspection that is impossible in war-time for lack of men. Rationing was carried out most successfully in Great Britain, and the great force behind it was the public sense of its need and the feeling that it was being administered with perfect fairness and no favour. Nor was the pinch of scarcity ever severe enough to break down the general moral; the people at large did feel hungry and were irked by the restrictions in their diet, but they could carry on and were not impelled to illicit traffic in order to obtain food. But since the farmer saw no dire need he felt no particular compulsion to change his ordinary way of living. It is not that the farmer is less patriotic than his fellow-men, but the war was far away from his countryside, and he is an individualist by temperament and habit, less subject to the crowd suggestion that draws the city dwellers into a common action, and with his accustomed routine as the most compelling factor in his psychology.

Should the occasion ever again arise it will be well to recognize that the agricultural community cannot be driven or subjected to the external control that proved successful enough with other industries; it must be organized from within to cooperate with the State. In this particular case agriculturists felt that their importance to the nation had been ignored in the early years of the war, and when the time came to regiment them in the common effort there was always a tinge of opposition in their attitude to the measures that were then forced upon them.

Speaking broadly, it may be said that, whatever criticism may be passed on the working of the control of prices in the United Kingdom during the war period, whatever may have been the defects in the system that have been noted above, these faults were inherent in the nature of the task and were not products of the administration. The farming community often felt itself oppressed, the consuming public often regarded itself as exploited, individual hardships were inflicted and in other cases ill-deserved profits were lightly piled up, but the control did work and did prevent an intolerable state of war between consumers and producers. Control there had to be, and one may look back upon it as a reasonably successful improvisation, characterized by the national qualities of fair play and compromise.

**AICARD, JEAN FRANÇOIS VICTOR** (1848-1921), French poet and dramatist (see 1.434), published after 1910 a collection of poems for children (1912) and *Hollande, Algérie* (1913), as well as various volumes of war poetry, a novel *Ariette des Mayons* (1917), and two volumes of adventure stories, *Un Bandit à la Française* and its sequel *Le Jumeau chevalier Gaspard de Besse*, both in 1919. He died in Paris May 13 1921.

**AINLEY, HENRY** (1879- ), English actor, was born at Leeds Aug. 21 1879, and was educated for business; but a meeting with George Alexander and an engagement for a "walking-on" part turned his thoughts to the stage, and he joined F. R. Benson's touring company for two years. He then appeared at the Lyceum theatre, London, in 1900 as Gloucester in *Henry V.*, and in 1902 at the St. James's theatre as Paolo in Stephen Phillips's *Paolo and Francesca*. He played Orlando in *As You Like It* both at the Comedy theatre in 1906 and at His Majesty's theatre in 1907. In 1910 he appeared there again

in many Shakespearean parts, and in 1914 he played Leontes and Malvolio in Granville Barker's production of *The Winter's Tale* and *Twelfth Night* at the Savoy theatre. After serving during the World War he began management at the St. James's theatre with Tolstoy's *Reparation* in 1919, following it up by a production of *Julius Caesar* early in 1920. In 1921 he played Prospero in *The Tempest* at the Aldwych theatre, and John Beal in *Lord Dunsany's If*.

**AIR BOMBS.**—Although the Hague declaration of Oct. 18 1907 contained a clause prohibiting, for a period extending till the next peace conference, the "discharge of projectiles and explosives from balloons or by other new methods of a similar nature," this declaration was only ratified by Great Britain, Austria-Hungary, the United States and Turkey France; Germany, Italy, Japan, Russia and Spain did not sign it, and it was therefore regarded as "practically without force" (British official *Land Warfare*, 1912, p. 24). The only limiting condition of aerial bombardment was, therefore, that applying to all bombardments, viz.: The prohibition of bombardments of undefended localities. The word "undefended" was not more closely defined; and it could be, and by some far-seeing authorities was, presumed that aerial bombardment of localities would certainly figure as an element of the "next Great War."

In the article AIR DEFENCE will be found an account of the principles of defence against air bombardment, as they were evolved in the World War of 1914-8. The present article deals with the bombs themselves, as material weapons, and with their accessories.

Projectiles dropped from aircraft, officially termed "Aerial Bombs," may be classified as High Explosive Bombs (H.E. bombs), Incendiary Bombs, and Bomb Parachute Flares.

1. *High Explosive Bombs.*—The principal use of H.E. bombs is to destroy material of all kinds; they are also used occasionally against personnel. They are a species of common shell, but differ from gun shells as, owing to the absence of shock of discharge, their envelopes require less strength, and consequently the proportion of weight of charge to weight of projectile is higher. With regard to their striking energy, bombs and gun shells, when fired at high angles, are comparable; but the striking energy of low-trajectory gun shells, other things being equal, is far beyond that of bombs dropped even from an extreme height. The field of action of a bomb is not restricted, as is that of a gun shell, by its extreme range, but depends upon the flying capacity of the aircraft employed; but the ballistic conditions under which a gun is used give an accuracy of fire which, in the case of bombs dropped from aircraft, is reduced to a minimum.

High explosive bombs are classified as *Light Case* and *Heavy Case*. Light case bombs, pear-shaped receptacles of mild steel, weighing when filled from 16 lb. to 100 lb., were made in great numbers in the early years of the World War. They were all of the same type. The case was made in two parts; the heavier, the nose end, was a hemispherical casting; the body was conoidal, tapering towards the tail end and the two parts were joined by an angle steel ring. In the 65-lb. bomb, for example, the nose end was 25 in. and the body 66 in. thick. As time went on the type developed; fig. 1 shows a

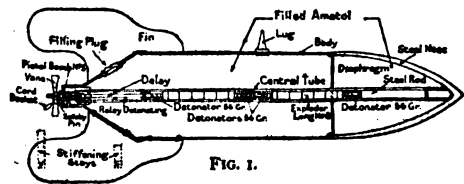

FIG. 1.

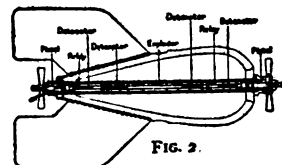

FIG. 2.

230-lb. bomb made of mild steel, .128 in. thick in the body and increasing to .375 in. in the nose. It carries 140 lb. of 40/60 amatol.

Light case bombs have practically no fragmentation and depend for effect on their charge alone. Heavy case bombs are made of single castings of steel or iron such as the heavy case 112-lb. bomb shown in fig. 2. Its cast-iron body varies from .5 in. to 1 in. in thickness and it carries about 28 lb. of 80/20 amatol. The fragmentation of these bombs is of the highest importance.

Bombs are usually provided with a central tube running their whole length, fitting into screwed sockets for which the bomb is tapped at nose and tail, except when the bomb, like the light case 230-lb. bomb, is provided with a sharp nose, when a tail socket alone exists. This central tube is divided into two parts by a steel ring called the *diaphragm* for convenience in loading and keeping components in their place. In the heavy case 20-lb. and 50-lb. bombs, the tail is prolonged outside the bomb proper by a light construction called a *fairing*, to provide a suitable shape for aerial flight. The 20-lb. bomb is peculiar in having only a nose socket and in the shape of its central tube. *Lifting lugs* are attached to many bombs. They are made of wrought iron and are riveted to the case so as to be in the same vertical plane as the centre of gravity of the filled bomb, when the latter is suspended in a horizontal position. At first bombs were released when horizontal; but now they are frequently suspended vertically from an eyebolt attached to the nose fuze or screwed into the nose socket. When a bomb is thus released, it turns over in flight and falls nose first. *Lifting bands* of steel are sometimes used in place of lifting lugs. Four *vanes* or *pins*, placed in quadrature, are riveted to the case of all bombs about the tail end, to ensure steadiness in flight. The interiors of bombs are varnished or lacquered; they are then filled with high explosive.

**High Explosives used in H.E. Bombs.**—Trinitrotoluene, known as tetryl and T.N.T., is used as the main charge of a bomb or as a topping to a charge of amatol, which on account of its hygroscopic nature has to be protected from damp. T.N.T., when compressed into pellets, is also used in exploders and relays. Amatol is used as a main charge for bombs. It is a mixture of ammonium nitrate and T.N.T.: at first it consisted of 40 parts ammonium nitrate and 60 parts T.N.T. (40/60 amatol); later on, 80 parts ammonium nitrate and 20 parts T.N.T. (80/20 amatol) was the mixture adopted. Tetranitromethylaniline, known as tetryl, Composition Exploding, or C.E., when compressed into pellets is used in exploders and relays. Fuminate of mercury is used for detonators.

**Bomb Components.**—Bomb components consist of fuzes, exploders, relays, detonators and igniters. Those selected for a given purpose are called an *assembly*. The assembly varies with the bomb and the purpose for which it is to be employed; but in every case an H.E. bomb is detonated on impact by the action of the striker of a fuze, which explodes a cap or patch of cap composition, detonating a relay or exploder, which detonates the main charge of the bomb. Exploders are hollow cylinders of sheet brass or paper filled with compressed pellets of T.N.T. or C.E. They are provided at one or both ends with metal envelopes or sleeves for the reception of the particular detonator with which they are to be used. Exploders vary in length and other details. Relays are exploders of a special kind, usually filled with pierced C.E. pellets; they are always next the fuze, to which they are sometimes attached by screwed thimbles called *adapters*.

Detonators are copper tubes of various sizes and are charged with from 45 gr. to 60 gr. of fulminate of mercury according to the use for which they are intended. When they are to be fired by a striker they are closed by a cap. Igniters are a special form of detonator, which carry between their charge and the cap a piece of match designed to cause a certain delay (up to 15 secs.) between the moment of impact of the bomb and its explosion. The match composition consists of nitrates and chlorates of potash, etc., mixed with shellac and methylated spirit.

**Fuzes.**—Both nose and tail fuzes are provided for H.E. bombs. The former are all on the percussion principle and are usually called direct-acting fuzes (D.A. fuzes). The first to be used by the British was a modification of the No. 18 gun percussion fuze made for a capped fuze hole. The motion of the striker, however, was controlled by a collar carrying two small vanes, called *arming vanes*. The vanes rotated as the bomb descended, eventually screwing the collar off the striker and leaving it free to act in the same way as it would in No. 18 after undergoing the shock of discharge when fired in a gun. A tapered fuze hole being found an unnecessary refinement in the nose bushes of bombs, the latter were tapped cylindrically and fuzes with corresponding threads were adopted. The latest development is the D.A. pistol (see fig. 2) which is an ordinary percussion fuze fitted at the top with a cover to which the vanes are attached, as is also a hanging eyebolt for the suspension of the bomb. At the bottom end the fuze is attached by an adapter to a detonator and relay and the assembly thus complete can be screwed into the bomb. In certain special nose fuzes the action of the vanes is utilized to screw the striker into position. Safety devices exist in all fuzes. Tail fuzes are all of that type to which the term pistol was originally given. (See figs. 1 and 2.) The striker at its upper end terminates in a screw upon which works a collar with vanes attached. As the bomb falls the collar screws off and releases the striker, which is then only held in position by a spiral spring; on impact this spring is compressed and the striker is forced down upon a cap which explodes the bomb. If desired, however, a match burning a certain

number of seconds may be interpolated between the cap and the charge, thus forming an igniter which secures the desired delay action.

When a nose fuze is employed the striker is on impact driven on to a detonator which causes a practically instantaneous explosion; but all tail fuzes must of necessity have a slight delay, for they only act after the speed of the bomb has been reduced considerably by meeting with some serious resistance, and this results practically in a delay of at least a quarter of a second, which delay can, as already explained, be extended up to 15 secs. by the use of Igniters. It is evident, therefore, that a bomb set in action by a nose fuze has no chance of penetrating a target before explosion takes place; there is but a small crater formed and fragments of the bomb are scattered over a wide area. A nose fuze, therefore, is used with heavy case bombs in the attack of personnel and light structures, such as aeroplanes in transit, where crater effect is not required. With tail fuzes, on the contrary, bombs falling in suitable ground will bury themselves before exploding, producing considerable craters but scattering no fragments. Tail fuzes in connexion with light case bombs are therefore employed in the attack of railways, dumps, buildings, and for general local destruction.

In the attack of certain buildings a combination of a nose and tail fuze is adopted. The shearing pin of the former is such as not to be broken as the bomb passes through the roof, while the tail fuze has a delay which will cause an explosion inside the building. If in such a case a tail fuze only were used, should the bomb break up on impact, the delay action might entail incomplete detonation or there might be no detonation at all. When bombs are made of cast iron both nose and tail fuzes are always employed.

**Carriage of Bombs.**—Filled bombs are stored with all sockets, etc., plugged; components are packed in their own receptacles. Before the various detonators, relays, fuzes, etc., which constitute the assembly, are inserted in the central tube of a bomb, the latter is tested in the dropping gear; when all is proved to be satisfactory the bomb is made "live"; but all safety devices are kept in operation till the moment of ascent. If a machine lands with bombs unexploded, all safety pins and other devices are made operative before the bombs are removed from the carrier.

**Sighting of Bombs.**—If a machine be flown directly on a target at a known constant height and with a known constant speed, a sighting apparatus can be employed from which, however, accurate results cannot be expected. Its use depends upon the following theoretical considerations: a bomb, when released, will continue to travel with the velocity of the machine and will pass over a horizontal distance before striking earth, which will depend on this velocity and the time taken to fall from the height at which the machine is flying. If then a right-angled triangle be formed with an altitude equal to the given height and a base equal to the horizontal distance passed over by the bomb, the slope of the hypotenuse will give the direction of the line of sight which must be employed.

The sighting apparatus is fitted with a horizontal wire which acts as a foresight and with three other similar wires which act as backsights, each for a given speed and height. Thus an observer using the backsight will have his line of sight so directed that when it passes through the target he knows he must release the bomb.

The heights and speeds provided for are: a height of 6,000 ft. and a speed of 90 m. an hour; a height of 10,000 ft. and a speed of 80 m. an hour; a height of 15,000 ft. and a speed of 70 m. an hour. The foresight is capable of fore-and-aft movement by which corrections for wind and density of the air can be given. Two fore-and-aft wires in the apparatus, placed vertically one over the other, serve in preserving the proper direction of flight.

**Typical Bombs.**—The following are typical bombs for the purposes named:—The 20-lb. is a small heavy case bomb, capable of carriage by light machines; it is used in the attack of personnel, aeroplanes and road transport. It is made of steel, its actual weight being 24 lb. it will take a charge of 4 lb. of 90/10 or 40/60 amatol or 1 lb. of 80/20 amatol. The 50-lb. bomb is a medium heavy case bomb for general use especially against material, and can be carried by the smaller bombing machines on long-distance raids. Its actual weight is 49½ lb.; it carries a charge of 10 lb. 80/20 amatol; it is made of cast iron, 4 in. thick in the body and ½ in. thick at the nose; the overall dimensions are 28½ in. long by 7 in. maximum diameter. It is sometimes carried vertically slung from the eyebolt of the nose fuze, sometimes horizontally when it is attached to the dropping gear by means of a steel band. The 112 lb. bomb is a larger heavy case bomb (see fig. 2) used for similar purposes in larger machines. The 230-lb. bomb is a large light case bomb, used for crater production in the attack of railways and buildings (see fig. 1).

In addition to these types of bomb, special bombs have been designed for special purposes. Thus the 336-lb. bomb was designed to effect demolitions by the distribution of heavy fragments. It carried a bursting charge of 70 lb. of compressed T.N.T. and the body was built up of bulged segments of steel 1 in. at their thickest parts. The 180-lb. bomb was designed as an armour-piercing bomb. It consists of a pear-shaped steel case varying in thickness from .9 in. to 3.3 in. from tail to nose, being provided with a cap of mild steel on the same principle as a capped armour-piercing projectile for a gun, and carrying a bursting charge of 20 lb. of 40/60 amatol or T.N.T.

A light case 520-lb. bomb has also been made for crater production and for use against submarines. When used in the latter capacity it has a special fuze to obtain "depth-charge" effect, a purpose for which the 65-lb. bomb was used in the early part of the World War. The actual weight of this bomb is 525 lb. and it carries 340 lb. 40/60 amatol. There is also a heavy case 550-lb. bomb, with a body of cast steel varying from .75 in. to 1.5 in. in thickness; it carries 180 lb. of 40/60 amatol.

As carrying power is developed, bombs tend to become larger; thus in a recent professional lecture (see *Journal of the Royal Artillery*, March 1921) a bomb of 1,650 lb. was spoken of, and even heavier types may be seen in the near future.

2. **Incendiary Bombs.**—In British bombs of present make the following compositions are used:—Thermalloy, which consists of 50 parts magnetic oxide of iron, 27 parts aluminium and 23 parts sulphur; thermitic, which consists of 76 parts magnetic oxide of iron and 24 parts aluminium; phosphorus; carcass composition, which consists principally of ground saltpetre, to which is added ground sulphur, sulphide of antimony, black powder and powdered aluminium, mixed with powdered resin, tallow and turpentine. The special match composition for igniters in incendiary bombs is approximately 34% chlorate of potash, 30% iron filings, 5% each of powdered aluminium and nitrate of barium and 26% shellac and methylated spirit.

The following are typical incendiary bombs:—The modified carcass bomb is made of tin plate, its overall dimensions being 19½ in. long by 5 in. maximum diameter. It is tapped at the tail for a pistol. It carries 3½ lb. carcass and 1½ lb. thermalloy composition, the total weight of bomb and pistol being 23½ pounds. It has two lifting lugs and is carried horizontal. During the loading of this bomb a former is employed to preserve the necessary cavity for the reception of the firing arrangement which consists of the pistol, the special igniter and the adapter and its attachment. The special igniter consists of a 28-bore Eley cap fitted with a copper sleeve containing a strip of instantaneous fuze, and the adapter is a screwed ring socket to which is attached a nozzle-ended celluloid tube loaded with 5 gr. of match composition. On preparation for action the igniter is pushed into the adapter, the latter is screwed on to the pistol which is then screwed into the bomb.

The caseless incendiary bomb is made of thermalloy moulded over an iron framework; its overall dimensions are 27.8 in. by 5 in. (side of square of maximum section). The total weight of the bomb is about 30 lb. of which 24½ lb. consist of thermalloy. The bomb can be stowed either in a vertical or horizontal position, and it is fired by a tail fuze and special igniter. It is fired in a similar manner to the modified carcass bomb, except that in addition to the pistol, special igniter and adapter, a length of instantaneous fuze is placed behind the nozzle of the celluloid tube.

The baby incendiary bomb consists of three parts, the body, the cartridge and the cap or cover. The body is cylindrical and of thin plate tin, but is weighted at the bottom; in the centre of this weighted portion is placed a short pin or striker. A little above the latter are two suspending lugs for the cartridge, made by partially cutting out two small portions of the plate on opposite sides of the body and bending them inwards so as to form a support. The cartridge, which is of the ordinary sporting shape, has a percussion cap in the centre of the base and rests on the two lugs. The cap or cover is dome-shaped at the bottom, above which are three vanes with a circular disc on top of them. The assembled bomb weighs about 6 oz. and is about 6 in. long by 1 in. in diameter. The bomb is carried on the machine with the vaned cap downwards, but on release it turns over and falls with the vaned cap upwards. When falling from heights of over 30 ft. the lugs on which the cartridge rests are on impact sheared or bent sufficiently to permit it to set forward on to the striker, when the cap is exploded and the cartridge case ejected and the thermitic ignited simultaneously. These bombs are always used in masses, and are packed in a special carrier which allows them to fall with a considerable spread; thus, to take a particular example, the 272 bombs packed in one form of carrier would, if released at a height of 5,000 ft., cover an area of 30 sq. by 80 yards. The carrier can be dropped complete if it is desirable to get rid of the bombs speedily, as in the case of a forced landing. With large bombing planes like the Handley Page, bombs can be distributed either by using several machines or by successive releases from a single machine. The small bombs provide a many-chance method of attack, which is not possible with the larger incendiary bombs, for with the latter a direct hit must be secured upon a combustible target and the chances are greatly against this combination being achieved. As, however, the small bombs descend in showers with a large spread and on impact further disperse their cartridges over the target area, the chances of a successful attack are considerable.

The 40-lb. incendiary and smoke bomb can be either burst on impact to produce a smoke screen or burst in air for the attack of kite-balloons, etc. It is made of tin plate .025 in. thick and carries 30 lb. of phosphorus. Its overall dimensions are 1 ft. 10.75 in. long by 8 in. maximum diameter. It is tapped at nose and tail and has a central tube for a burster containing C.E. pellets and black powder. When used for smoke production a D.A. pistol is screwed into the nose and the tail is plugged, but when an air burst is required the nose socket is plugged and a special time fuze is screwed into

the tail socket. The bomb when burst in air spreads out a shower of burning phosphorus over a circle of some 250 yd. in diameter. The lumps of phosphorus slowly burn out in falling and about half are used up in the first 2,000 ft. from the point of burst. If the latter be 3,000 ft. above the target the bomb will be practically lost. The special time fuze employed, the Madgeley fuze, is set in action by a striker, normally held back by a spring in compression, which is released by a trigger when the bomb is dropped.

The **Ranken Dart.**—This dart, invented by Engr.-Com. F. Ranken, was used for the attack of Zeppelins and for other purposes. It consisted of a hollow tin cylinder, about the size of a large candle, the bottom was closed by a pointed bullet of steel or iron, and its top by a lid of tin through which passed a spindle capable of vertical movement and terminating at the end outside the dart in four flanges or vanes. The cylinder was filled with incendiary composition which was fired after the fashion of a Christmas cracker. For this purpose a strip of friction match had one end attached to the cylindrical body and the other to the spindle. Then if the dart fell upon a Zeppelin from above, its sharp bullet point would enable it to penetrate the outer covering upon which, however, the four flanges or vanes would catch; a jerk would thus be given to the spindle causing the match to be torn apart and ignited, and the dart, held fast in the cover of the Zeppelin, would burst into flames.

3. **Bomb Parachute Flares.**—These flares are used for reconnaissance at night, for illuminating and showing up ground held by the enemy, and for affording light to a pilot wishing to land in the dark. The flares are cylindrical paper tubes filled with aluminium composition and primed with magnesium composition; they are sometimes called candles. They are lighted by means of pieces of quickmatch attached to the primed end, the other end being fixed in a cup arrangement which is attached by a wire rope to the parachute.

Electric-Ignition Parachute Flare-Bombs are of two kinds almost similar in construction. One is used as a reconnaissance flare, the other as a landing flare to enable pilots to land in the dark. They are both launched by means of a launching tube attached to the fuselage of the aeroplane, and so designed that as the bomb leaves the launching tube an electric circuit is completed, and a platinum-silver wire bridge heated. This, by igniting a priming, sets a delay pellet in action and, after the bomb has dropped some 1,000 ft., a powder puff is fired, which both ignites the candles and projects the parachute clear of the cylinder. The reconnaissance flare (with a 9 seconds' delay pellet) burns for three to four minutes, weighs 6 lb. 13 oz., and has a parachute weighing 11 oz. and measuring about 5 ft. 6 in. across when open. The landing flare weighs 5 lb. 4½ oz., and has a parachute of the same size and the other but of lighter material, weighing only 3 oz. The candles burn for from 2½ to 3½ min., and the delay pellet only gives one sec. delay so that the bomb opens after it has dropped some 20 feet. In both bombs the idle power is about 40,000. (I. R. J.)

**German Air Bombs.**—The general characteristics of air bombs being the same in all countries, British practice may be regarded as typical and foreign bombs need not be dealt with. Some notes on German air bombs are added, however, on account of the special interest attaching to these projectiles, which for the first time for many centuries brought war to the very doors of the British people.

The earliest types designed by the Germans were so far ineffective that as early as the spring of 1914 they were replaced by bombs of a type known as "Carbonite." These bombs, which were used throughout the earlier part of the war, were pear-shaped and solid, pointed, and had a propeller-actuated pistol of the same type, as those described earlier in this article. Their special characteristic was the form of air-drag used: instead of fins, a sort of inverted tin cap was used, attached to the tail of the bomb by stays. The smallest of these bombs weighed 4½ kgs. (about 10 lb.), and the heaviest 50 kgs. (110 lb.). Small incendiary bombs of the carbonite type were also used. There was, further, a grenade-like projectile thrown by hand, which weighed 800 grammes (1½ lb.), but this was criticised as being too small to be effective, as also was the 4½ kgm. H. E. carbonite bomb.

In 1915 these bombs were replaced by a different type known as "P. and W." which continued in use to the end of the war. They were torpedo-shaped<sup>1</sup> and were fitted with slanting vanes which not only acted as an air-drag to keep the projectile nose down but also imparted rotation to the falling bomb, and so enabled the German designers to replace the propeller as an arming device by centrifugal bolts, on the same principle as those of gun fuzes. As the height at which bombs were released had by that time greatly increased, the additional time required for the arming of the fuze was of no importance. Time fuzes were also employed, chiefly for obtaining delay effects after impact.

The standard sizes of these "P. and W." bombs were the 12½ kgm. (27 lb.)—a thick-walled bomb with instantaneous fuze—and the 50, 100, 300 and 1,000 kgm., "mine" or thin-walled bombs, with bursters respectively of 23 kgm., 60 kgm., 180 kgm., and 680 kgm.

One other form of air projectile should be mentioned as, although it was never used on any large scale, it had a moment of notoriety

<sup>1</sup>Torpedo-shaped bombs were also used by the French, who named them "pisiforme" (fish-shaped) bombs, in contradistinction to "pierreforme" (pear-shaped).



in the early stages of the war. This was the dart, a heavy bullet of steel sharpened to a point at one end. These darts, released in showers, were intended to be effective against personnel.

(C. F. A.)

**AIR DEFENCE.**—Even before aerial navigation and aviation had been developed to a practical point, the employment of aircraft in war for the attack of vulnerable places was discussed from time to time in a speculative way, and in the seven or eight years preceding the World War the types and characteristics of aircraft became so far definite that technical study could be brought to bear on the problem of defence, especially that of artillery defence. But this period of seven or eight years was short; military history could give no lead; practical experiments were almost impossible. Moreover, in the existing state of international law, liability to air attack was understood to depend not on whether a place was vulnerable, in the sense that its destruction would impair the capacity of the nation for carrying on the war, but on whether it was "defended," *i.e.* fortified in the conventional sense of the word, or at any rate held by a ground garrison against ground attack. Attention was therefore directed chiefly to the question of air attack on what according to the prevailing ideas were "military" objectives, and in view of the small numbers of aircraft then available such attacks were regarded as unlikely to affect the course of operations seriously.

In these conditions, and especially in the absence of all data based on practical experience, it is not surprising that defence against air attack was everywhere in a rudimentary state at the outset of the World War. In the war itself, on the contrary, experience, data and methods crowded upon one another from first to last, and through the clearer definition of the problems to be faced on the one hand and the constant process of trial and error on the other, it has become possible to formulate the main principles of air defence with some approach to precision.

### I. General Considerations.

Air defence, as discussed in the present article, deals with the arrangements which deny to enemy aircraft access to vulnerable points. By "access" is implied the gaining of a position either directly over the objective or sufficiently close to it for the success of the attack. Amongst "vulnerable points" are included bodies of troops and their *matériel* in the field, centres of population, large magazines, arsenals, harbours, ports, dock-yards, ships and convoys at sea, big industrial centres, and the like. As with a fleet, the primary duty of the air forces is to seek out the enemy air forces and destroy them; but the problem in the air is far more difficult than on the sea, as a third dimension has to be taken into account, *i.e.* that of height. When we remember what difficulties have been introduced into naval war by the introduction of the submersible warship, slow as this is and small as is its up-and-down range, and when we realize further that, in the air, opposing craft can pass at great heights both above and below each other, move at speeds that are enormous relatively to any rate of movement on or under the sea and have to cope with extraordinary difficulties in detecting one another's proximity, it will be seen that the task in front of the air forces of any nation is the most difficult of all.

There is no "command of the air" while the enemy disputes it. Therefore, against attacks by air, it is a logical necessity to provide ground defences, and to limit the radius of the air units allotted to cooperate with them. But though defence against attack by air, as on the ground, may be active or passive, yet to be effective it must be both. Further, the conditions under which aircraft move, by day and by night respectively, are so widely different, that the conditions of the defence must be correspondingly varied to meet them.

It is not intended here to deal with operations launched over long distances against enemy aerodromes and depôts, such being the rôle of the air forces alone, but solely with the local defence of areas occupied by "vulnerable points" of the kind which have been enumerated above.

The instruments of air defence are:—(a) the machine-gun on the ground; (b) the machine-gun in the aeroplane; (c) the

heavier guns on the ground; (d) the searchlight, the sound locator, the observer post; (e) the aerial obstacle; (f) local protection on the ground, *i.e.* against bomb splinters and machine-gun fire, and camouflage.

Each of these weapons supplements a deficiency in one or more of the others; none is complete without one or more of the others acting in conjunction with it. From this it follows that, in any anti-aircraft organization, cooperation in effort can only be effected by organizing units of the air force, artillery and engineers under a single command, as in a formation of all arms in ground warfare.

The following are some of the forms which attacks by air may take:—bombing by airships, aeroplanes or seaplanes, singly or in formation; the harassing of troops on the ground or sea with machine-gun fire by aeroplanes or seaplanes, singly or in pairs; torpedoing ships at anchor, by seaplanes, probably in pairs or escorted by "scout" (*i.e.* air fighting) machines. To these may be added, though they only indirectly affect the problems here discussed,—photographic or visual reconnaissance, by aeroplanes or seaplanes, singly; and aerial engagements, by aeroplanes in formation on hostile patrol, *i.e.* ready to engage air-fighting groups of the enemy, or by aeroplanes, singly or in groups, attacking machines which are engaged in observation duties (especially artillery observation) in connexion with ground operations.

Anti-aircraft units are concerned primarily with hostile attacks the objectives of which are on the ground or sea; the defence of objectives in the air is a secondary matter, but nevertheless important when air-force units are not at hand to undertake the duty themselves.

It may not be amiss at this stage to mention a few of the peculiarities of sound and light. Although these properties are generally known, their full importance in relation to air defence is seldom recognized by those who have little experience in anti-aircraft work. Sound travels at a certain known rate, namely about 1,100 ft. per second. Aircraft are generally first detected by ear. By the time the sound of a machine reaches the ear, the machine making it will have moved some distance away from the spot where it made the sound. A path of sound is deflected by the different velocities of the various air currents through which it passes on its way to the ground. A machine in the air is only visible to an observer on the ground by reason of light rays reflected from the surfaces of the machine, reaching his eye in sufficient intensity to enable him to detect it. Thus a machine flying "straight into the sun" is invisible to an observer also facing the sun. A spherical or cylindrical surface reflects light chiefly in the direction from which the illumination comes; hence, in the case of a balloon or airship, the observer sees the target best when he and a searchlight are on the same side of it. A flat surface reflects light towards an observer further from the source of illumination than its own position; thus an aeroplane flying steadily in a searchlight beam is generally seen best when it is between the observer and a searchlight. It does not follow that because aircraft are invisible to observers on the ground the ground is invisible to an observer in the machine, and *vice versa*. The greatest difficulty is frequently experienced in gaining the correct focus for the eye, and, having gained it, to maintain that focus. This is a difficulty common to the observer both on the ground and in the air, but whilst the former has only to look upwards, the latter has in addition to look all round and below his machine. Neither has the assistance of intermediate objects by means of which the focus of the eye can be altered and held at definite stages. By day the observer in the air is deaf, by night he is deaf and blind. A searchlight shining into the sky is only visible by reason of the particles of "dust" or moisture in the path of the beam. In a perfectly clear or clean atmosphere the beam is invisible.<sup>1</sup>

<sup>1</sup> Unusually clear atmospheric conditions with a few high clouds were responsible for popular rumours prevalent during the war in 1914-8, to the effect that a new invisible searchlight had been discovered which simply threw a disc of light far away up in the sky, and was otherwise quite invisible.



### II. Conditions affecting the various Instruments of Air Defence.

(a) The machine-gun on the ground, on account of its comparatively short range, can only deal with targets flying at low heights, e.g. up to 3,000 or 4,000 feet. On the other hand, the ease with which it can be handled enables it to cope with the rapid change in angular velocity of low-flying targets in a way which the heavier guns cannot do. Low-flying machines move over their ground targets with a very rapid angular velocity, and owing to their small height they are often invisible from the ground objective until at a close range. Every unit of an army, therefore, requires anti-aircraft machine-gun equipment for its own local protection.

(b) The machine-gun mounted in the aeroplane can attack its target at close range, and, if its own aeroplane is superior to the target in speed and in climbing and manoeuvre power, can maintain that attack until the combat ceases. It is therefore of great importance in air defence.

Mention has already been made of the difficulties of seeing objects other than on the ground, and of hearing; and to overcome them it usually becomes necessary to direct the pilot and observer by signal (visual or wireless) from the ground, to assist them in finding the target which has been selected for attack.<sup>1</sup> Other serious handicaps to the observer in the air are the unstable platform for his gun and the difficulty of estimating the range to his target.

(c) The heavier gun on the ground acts in coöperation with the machine-gun in the air, and in substitution for it when weather conditions or other reasons prohibit the use of the aeroplane.

The gunnery problem is an extremely intricate one owing to the difficulties involved in range finding, the rates of change in angular velocity, the ease with which a target can change its height and course, and the fact that the target can only be engaged for a very limited space of time. The difficulties of the artilleryman originate from the time of flight of his projectile. On the other hand, he is not hampered as is the airman by the unstable platform and by the noise made by the engine.

(d) The searchlight has three rôles to fulfil in air defence. (1) It points out the selected target to the defending aeroplanes. At night the pilot is deaf and practically blind, and, unless he carries a searchlight in his machine, he must depend on those on the ground to show him where the target is moving. (2) It illuminates it for the artillery. The artilleryman on the ground is blind, and cannot use his sights unless his target is well illuminated so that he can see it. (3) It exerts a moral effect deterrent to the attack. It is necessary to read the personal narratives of night-flying pilots, and to listen to their conversations, to appreciate the great moral effect which the systematic and unhesitating use of searchlight beams has upon them when they are approaching their objectives on the ground. They know that once the searchlight succeeds in laying on them they become the target for every gun and aeroplane within reach—an experience to be avoided as far as possible.

There are peculiarities in a searchlight beam which handicap the detachment to a large degree; the principal one is the frequent inability of a man standing close to a projector to see a target in the beam from it. This is sometimes due to a general prevalence of a local mist which diffuses light in all directions in the neighbourhood of the projector, but it may also be due to the blinding effect of a secondary cone of light close to the base of the main searchlight beam, which prevents the man close to the projector from detecting the light reflected from the target. At distances, however, varying from 6 to 20 ft. to one side of the projector, the effect of this secondary cone of light is generally so slight as to cause no interference. Projectors have accordingly been provided with long control arms fitted with wheels or handles at the end, so that the man whose duty it is to manipulate the beam can do so with the minimum of outside assistance.

An aeroplane can, by "side slipping" or otherwise executing some unexpected manoeuvre, generally escape from a single illuminating

searchlight, owing to the differences in the reflecting surfaces of an aeroplane when viewed from different angles. If, however, three beams manned by good detachments succeed in training on it, they can generally hold it whatever the gymnastics attempted by the target. On the other hand, if a target is illuminated by a comparatively large number of beams, say eight or ten, some of which must be at a considerable range from the target, there is a marked tendency for the latter beams to drop below the target altogether; although the detachments at those projectors are unaware of the fact that their beams are now useless, and may even interfere with the vision—and consequently the work—of detachments nearer the target.

An incident which took place during the German airship raid on London on the night of Sept. 2-3 1916, has been attributed to a reason of this nature. The Schutte-Lanz airship SL11, which was eventually burned that night and fell at Cuffley, was entering the area over London from a northerly direction. London itself was lying in what looked like a lake of mist, and the searchlights, which could hear the attack approaching over them, were seeking for it through the mist. Presently the airship was "picked up," and immediately from all quarters of the defences searchlights could be seen moving across to get on to it, until there may have been any number up to 20 beams shining in its direction.

The airship seemed to hesitate, and then swung round until she was steering north again. She was seen to empty one or more of her water ballast tanks and suddenly disappear. The searchlights lost her entirely for some minutes. Though, as is well known, she was eventually detected again and then held until she fell, there is little doubt that the searchlights were, in the first portion of the engagement, hampering each other in their work owing to the exposure of too many beams.

In the same engagement a searchlight near Kenton was quite useless owing to a dense mist surrounding it and the gun station near by. The local reflexion of the light by the mist was so great that it prevented either gun or light detachment from seeing the target.

During the first years of the war discussions were often heard as to the advisability of throwing out searchlight beams, on the assumption that the target might not know where it was, and might therefore pass away without dropping any bombs; in other words that the exposure of searchlights invited the arrival of bombs. The answers to these suggestions are simple, viz.—

(i) The searchlights are there to be used, because guns and aeroplanes are blind without them. Guns and aeroplanes cannot defend efficiently without seeing their target.

(ii) There is no justification for the assumption that the enemy has lost his way and does not know where he is.

During the spring of 1917 a general display of searchlights round London was arranged to test their efficiency as a moral deterrent on airship commanders. Every searchlight in the London area was given a prearranged arc through which the beam was to be moved slowly and regularly at a given signal, the movement to be continued indefinitely until the signal was cancelled or enemy aircraft became audible or visible to any of the detachments. The intention was to expose all the beams (some 120) simultaneously as soon as an attack was heading towards the London area, but whilst it was still sufficiently far away to give the airship commander plenty of time to think matters over, and remind him of the aeroplanes and guns which were waiting for him, and of the fate of some of his predecessors. On the two occasions when this scheme was put into force the attacks stopped short of the defended area and never came near it, though the German official communiqué announced on each occasion that they had dropped bombs on London.

A searchlight and its detachment are very vulnerable when within range of shell and machine-gun fire. On some occasions aircraft have occupied themselves in deliberately bombing searchlights, though the instances have been rare in England, and in no case was harm done either to the searchlights or to their personnel. On the other hand, in the areas where ground fighting was in progress, searchlights formed a vulnerable target for machine-gun fire from low-flying aeroplanes, though actual casualties were comparatively few.

The sound locator is an instrument which is intended to indicate the angle of elevation, and the bearing in azimuth, of aircraft audible but invisible from the ground.

Many types of sound locator were invented and tried by the various nations involved in the war, but none was eminently satisfactory. The fact of the matter was that but little was known of the vagaries of the paths of sound waves in the atmosphere. During and since the war, however, students have begun to appreciate and learn a few of its peculiarities, though at the present time knowledge of the subject is still little more than in its infancy. The pattern of sound locator most commonly used in the war was one with four trumpets, two for obtaining the direction in elevation and two for obtaining it in azimuth. In order to convey the information to the searchlight itself in as instantaneous a manner as possible, the locator was provided with a "ring sight," on the edge of which the searchlight beam was kept in contact by a "layer," who gave suitable directions to the men at the projector.

<sup>1</sup> By day the visual signal may be given by gunfire. By night it is more often made by the searchlight. For this purpose the Germans in Belgium erected large illuminated "arrows" composed of incandescent lamps in troughs of wood, designed to revolve on the spots of concrete shelters.

A defect of this type was its inability to eliminate certain sounds which had nothing to do with aircraft, such as those from petrol tractors, motor bicycles, etc., on the ground in the neighbourhood. The Germans in Belgium had to give up using their instrument at a searchlight near Bruges, because of the noise made by the frogs in the dykes all round it.

Another pattern of sound locator has been constructed in cliffs on the shore by cutting a concave surface in the face of the cliff, and providing an appliance for collecting the sound waves at their point of maximum concentration, in such a way as to indicate approximately the direction of the source of the sound. This pattern was used on the British coasts and warned observers of the approach of machines from Belgium when the latter were as far away as 15 to 20 miles. These locators also, however, were liable to error; and on one occasion a fleet of motor-boats caused an alarm which was anti-prevented from becoming public by the perspicacity of the local anti-aircraft commander.

The functions of the *observer post*, which may or may not be equipped with detector apparatus, are of great importance. The duty of the observers is to detect the passage of aircraft and report their movements to the authority controlling the air defences. On these reports depend the warnings to the civil and military authorities within the defended areas. Such duties demand considerable physical strength to bear the severe strain incurred by watching and waiting; and a high degree of refinement in hearing and eyesight, owing to the necessity of detecting and identifying aircraft at great distances. The speed of aircraft in the attack is the factor which determines the minimum distances of the posts from the objective, and those distances may involve the disadvantage of great isolation for many posts. The necessity of good and speedy means of communication between such posts and the controlling air defence authority to which they belong is obvious. However excellent an observer's training may be, a report based solely on what he has heard must be open to doubt, should it attempt identification of the class of the aircraft in question.

(c) The *aerial obstacle* consists of some form of wire impediment hung from balloons, and intended to be such a menace to a flying machine that it will either pass beside the obstacle or, more probably, fly at a higher level than the balloons supporting it.

The Italian authorities claimed extraordinary success with the contrivances used in their defences. The French authorities were not so optimistic over the type adopted by themselves, and there is no proven case of success with the pattern used in Great Britain.

The Germans at Bruges and Zebrugge flew kites and balloons by wires of a very high tensile strength, and one Handley Page bombing machine with its crew was destroyed at Bruges by these means. The balloons were about 15 ft. in diameter and were used when wind power was insufficient to raise a kite. The kites were of at least two patterns, but both were of the double box-kite type. The lower ends of the wires were wound on vehicles provided with gauges, oil baths, and lightning "earths." They were managed by a few small boys, pressed into the German service at the rate of a few francs a night. It was calculated that the wire provided an obstacle up to about 3,000 feet.

In Great Britain balloons moored by wire cables were arranged in lines, and at some distance below the balloons was a bridle connecting all the cables. From this bridle at equal intervals were suspended long thin wires of considerable tensile strength.<sup>1</sup>

Any arrangement of obstacles suspended from balloons must be particularly vulnerable, both from the shell fire of the defence and from any machine-gun fire brought to bear by the attack.

Many other forms of obstacles have been suggested from time to time, and perhaps one of the most ingenious was that of an aerial minefield. The inventor proposed to attach a small charge of explosive, sufficient to destroy an aeroplane wing, to a revolving vane by a length of fine cord. The charge was fitted with suitable percussion firing arrangements. The vane was attached for the purpose of delaying the fall of the explosive through the air. Charge, cord, and vane were neatly packed together so that considerable numbers could be carried in a box provided with a simple release. The pro-

<sup>1</sup> A curious incident occurred during an air-raid alarm in London during the war. To the astonishment of the detachments one complete series of balloons came down with unexpected suddenness, all being deflated by the rupture of their ripping panels. On examination it was found that moisture had condensed on the ripping ropes and frozen there, until each cord was about as thick as a man's forearm. The weight had gradually increased on all with remarkable regularity until the ripping point was reached, when each balloon in the series was deflated almost simultaneously. There was a heavy mist that night, and the temperature at the ground level was above freezing-point.

cedure proposed was to send up a group of machines loaded with these "mines," on patrol well outside the defences, on any occasion when conditions were so favourable that a raid was probable. The "mines" were to be released across a broad belt through which the attack would probably pass, as soon as a signal was made from the ground that it had reached a suitable point on its course. The idea, however, was never carried into effect—probably owing to the danger involved to friendly machines—but nevertheless it had possibilities which gave considerable promise, especially for use over the sea.

(f) *Bombproof and Splinterproof Protection.*—Local protection for personnel, animals and stores involves the provision of sheltera proof against the bombs themselves and their splinters. A bomb with a stout and heavy point, and provided with a means to keep it revolving so that the point travels first, will, if launched from a great height, penetrate most practicable forms of shelter. A stout double roof of concrete with the sides sloping fairly steeply, and provided with a "sandwich" of some resilient material between the roofs, will probably give protection to what is beneath it, provided that the foundation supporting the roofs is a good one.

Many bombproof shelters made of concrete or big stones cemented together were constructed in France and Belgium by all belligerents, but they were generally of small capacity, and provided for particular detachments whose duties necessitated their remaining in the vicinity at all times. It is not, however, possible to provide such protection universally; in most cases all that can be done is to minimize the danger as far as is practicable, and to accept the fact that a direct hit on, or an explosion very close to, the person or animal will finish the matter as far as they are concerned. A little-known fact is that the open spaces in a big city like London may amount in total area to nearly ten times that on which houses are actually built; the chance that a bomb will fall on a house being therefore far less than is generally recognized.

The heaviest bombs used by both sides in the war made craters about 35 ft. in depth when dropped on ordinary soil and open grounds. These bombs were fitted with fuses with a slight delay action. A light bomb with a very sensitive fuse was used by the Germans with deadly effect against men and animals. The crater made by it was practically negligible, all the fragments flying outwards and upwards. Protection against this type of bomb was afforded by low parapets of sandbags or sods, close to which troops could lie; but horses were extremely difficult to protect against these so-called "daisy cutters." In the open, protection during a bombing attack will generally be best found by lying down—in a depression if one be available.

In houses it is difficult to say which position is the safest; a bomb with a delay-action fuse will probably blow the whole house up from roof to cellar, while one with an instantaneous fuse will probably blow the roof in. On the whole, it would appear that the safest position of all is near the chimney breast in a room on the first floor, and below the level of the window sill. Such a spot may give protection from debris falling from the roof, and from splinters from a bomb bursting in the road outside, but is of course not likely to be of any use if the whole house is blown up.

Torpedo nets arranged in tiers about 10 ft. above each other may provide a certain amount of protection against small bombs fitted with instantaneous percussion fuses, but they are costly and difficult to erect.

*Camouflage.*—Concealment of the ground target may take more than one form. The landscape may be studied from the air, and the vulnerable points treated in such a way with painting, and netting and so on, as to assimilate their appearance as far as possible with the surrounding country. Again, attempts may be made to hide an important point with smoke clouds during a raid, but unless the work is very carefully done the smoke may invite attention to the possible objective rather than conceal it. In any case it involves much careful organization, and may in the end prove very expensive. Lights and dummy buildings may be placed in exposed positions so as to form attractive targets for hostile bombing machines, at a safe distance but not too far from the point actually sought by the enemy. Thus a carefully arranged target of green, red, and white lights, may successfully simulate and so protect an important railway junction.

Concealment of the principal leading-in marks has frequently been suggested; but success would only be likely with objects which were of small size, and therefore probably of comparatively small importance. For a big objective such as London, where there are such prominent guides in the nature of rivers, railroads and valleys, the expense of concealment would be enormous and the probability of success negligible. Moreover, the developments of wireless tele-

raphy for directional and position-finding purposes would almost entirely neutralize any such work if it were attempted, on account of the size of the target. (See also CAMOUFLAGE.)

### III. Forms of Attack.

The effects of bombing are moral and material. There is no doubt that the moral effect is far greater than the material—particularly in thickly populated districts where self-control, as a general rule, will be found lacking in the population to a greater degree than amongst armed forces in the field. No result decisive to a campaign has been brought about by a raid of any kind of itself alone. This fact will probably be true of aircraft bombing operations, provided that a country has taken suitable precautions in peace against the chance of an overwhelming attack at the very outbreak of war.

Written evidence was found during the war of the nervous apprehension reigning in a certain German town after the British special raiding force known as the "Independent Force, R.A.F.," had been operating for a comparatively short time. One of the inhabitants described a night of terror in which Allied aeroplanes had come in the early night and dropped their bombs and gone away. No sooner had the inhabitants come out of their shelters to go to bed than they were again summoned under cover, and the bomb dropping was repeated. Again they went to bed, and again they had to take cover—the performance continuing in this manner for some three or four hours. As a matter of fact one solitary Allied aeroplane paid a single visit to the town that night; the rest of the raid was purely imaginary, and the result of demoralization! Over another large town six long air raids took place during eight nights. One effect was that the clothing output from that district was temporarily reduced by 80%—a serious matter for the army, as a large proportion of the force was depending on the district for its clothing.

Bombing operations over disciplined forces in the field constitute on the whole a form of annoyance rather than a potential danger, provided that store and ammunition depôts are so designed as to be separated from each other, and subdivided within themselves, in such a way that a fire arising in one section may be properly isolated and prevented from spreading to its neighbours. Interference with movements of troops and stores by rail can be, and has been, caused by low-flying bombing machines.

**Airship Attack.**—Airships form targets of great size, and, if filled with inflammable gas—as were those of the Central Empires during the war—are objects of considerable danger to their crews. If and when a suitable non-inflammable gas is discovered which can be produced cheaply for commercial purposes, the airship will become a serious factor in air-defence considerations. It possesses greater endurance, radius of action, carrying capacity, accommodation, and facilities for observation than "heavier-than-air" machines. Meteorological conditions, however, will always militate more against the free use of airships than of aeroplanes, which possess higher powers of manoeuvre and performance.

During the war bombing operations by airships were not intentionally undertaken by the Germans over land targets by day, but ships at sea were frequently made the objects of such attention between dusk and dawn. Airships intending to attack land objectives in the British Is. used to leave their sheds by day, and make their landfall while still over the North Sea. There they would wait until it was dark enough to cross the coastline without prospect of serious interference, and make for their various objectives—as a rule more or less independently, but sometimes in pairs. The return journeys were made independently.

It has been held that at night it is hardly necessary to attack with more than one airship at a time, but there is no doubt whatever that simultaneous attacks by two or more airships on the same course add enormously to the difficulties of the defence.

The German raid on London during the night of Sept. 23-4 1916 affords a notable instance of airships setting out to attack in pairs, but failing to carry out their intention. L31 and L32 sailed on the task in company and reached Dungeness together. Thence L31, commanded by a bold and skilful pilot, set her course straight across London at high speed, and eventually won through. Her consort hesitated, and was lost.

L31 passed over Purley and Croydon, and dropped a very brilliant flare as she turned on a northerly course. This undoubtedly had the effect of distracting the ground defences from herself; for she was scarcely seen as she passed over the metropolis, and bombed it heavily without damage to herself. She reached home in safety.

L32 waited near Dungeness for about 40 minutes, and then flew north over Tunbridge Wells, instead of following L31. She avoided London, and dropped her bombs between Westerham and Ockendon. Near Bilkercay she was destroyed by fire.

Although there would appear to be much to commend such a course, "fleet" movements of airships in formation with the intention of bombing were not carried out by the Germans. However, it does not necessarily follow that a big attack of airships, either by themselves or conveyed by aeroplanes, will not form part of an extensive bombing operation in the future. The arrival of such an aerial flotilla over a capital city at the very outset of a war would do much to spread despondency and alarm; and if such a fleet succeeded in getting away unscathed, the attack might suffice to overturn all government in the state attacked.

**Aeroplane and Seaplane Attack.**—Bombing aeroplanes<sup>1</sup> by reason of their speed, difficulty of destruction from the ground, and comparative ease of handling in unfavourable weather, form the most serious factor in air attack.

The first aeroplane raid on London by day took place about noon on Nov. 28 1916. This was carried out by a two-seater machine carrying about half a dozen light bombs and flying at a high altitude. It was a courageous effort. Engine trouble brought the pilot to the ground on French territory, where he was captured with his observer. London was covered with clouds of dust which prevented all but a very few from ever seeing the machine. The success of the effort made it all the more surprising that it was never repeated; subsequent attacks in daylight were all made by machines flying together in considerable numbers and not singly. The most notable was that which took place on July 7 1917.

Before Sept. 1917, only a single attack on London was made by aeroplane by night. In that particular case (May 6-7 1917) the attack was made by a solitary machine which dropped most of its bombs on Hackney Marshes.

With these two exceptions, aeroplane and seaplane raids on England by day and night were limited practically to coastwise towns and shipping at anchor till the beginning of Sept. 1917, when aeroplane attacks on London by night were commenced seriously. These seem to have been made at first by machines in groups of three to five in number, but at the end of the same month, two groups appear generally to have split up on reaching the English coast, each machine taking its own line independently from that time onwards.

Machine-gun fire from low-flying aeroplanes and seaplanes will be encountered wherever targets present themselves: troops in action, in camp, or on the march, transport in movement, troops crowded on shipboard. But here again the principal effect will be moral rather than material.

Where ships lie at anchor in open roadsteads, or in harbours which offer a direct line of approach from the sea of moderate length, seaplanes will find targets vulnerable by the marine torpedo. The launching of the torpedo involves a close approach by the torpedo-carrying machine to the surface of the sea, and complete occupation for the crew of the machine. Those facts render it necessary that such machines be escorted by one or more fighting machines, whose duty it is to protect them from attacks by air and if possible from fire from the shore and ships. Various methods of active protection suggest themselves—the destruction of the machine, harassing its aim, or deflecting the torpedo during the launching process.

Photography of the ground for intelligence purposes forms a highly important feature in aircraft work. With good lenses, photographic machines can do their work at immense heights, thus rendering their detection by the defence a matter of considerable difficulty.

Aeroplanes on hostile patrol constitute an armed guard whose duty it is to seek for enemy machines. Such patrols form targets for air defence formations when they are within range and the air forces proper are not at hand to take up their challenge.

Friendly machines acting as auxiliaries to ground operations—especially artillery machines observing the results of gun fire—are

<sup>1</sup> The paragraphs which follow are applicable also in the main to seaplanes. Nevertheless the typical differences between the two classes are not without importance from the point of view of the preparations against attack by one or the other. The principal difference is that seaplanes require no landing ground or special arrangements for landing on ships. They can also take in their fuel from ships. On the other hand they find difficulty in "taking off" in rough water. Their powers of manoeuvre are, however, comparatively limited. They come chiefly into the consideration of coastal air defence, owing to the necessity they are under of landing on water. But amphibious machines are certain developments of the near future, and wide canals such as that between Bruges and Zeebrugge have served as landing places and enabled seaplanes to operate from a point inland and safe from interference from the sea.

at a serious disadvantage if attacked by enemy aircraft, as their duties tie them to a comparatively small area at a fairly low height. To defend each of such machines by an aerial escort would absorb too great a number of fighting aircraft, and so the duty falls most frequently on the anti aircraft artillery and such machines as are allotted for air defence work—*provided that the latter can be directed to the spot in sufficient time to provide the protection required.*

IV. The Defence in General.

It will now be realized that air defence is required both in the actual theatre of active operations in the face of the enemy, and in areas far to the rear of the fighting line, so long as the enemy has machines capable of reaching those distant points and returning again from them. Bombing attacks may be met anywhere, *i.e.* both in the forward area of ground operations—the “Front”—and also in store depôts, bases, ports, and large cities far removed from them. Low-flying machines with bombs or machine-guns may be encountered far in rear of the “fighting line,” but principally in or near it and over the communications immediately behind it; so that, as a broad general rule, the nearer the “line” the greater will be the proportion of low-flying targets, and *vice versa*. Torpedo-carrying machines will be met with over the sea; and photography machines anywhere between the “line” and points far in rear of it on the lines of communications.

In order to place defending aeroplanes in positions favourable for engaging their targets, it is necessary to obtain information of the attack in sufficient time. This leads to two great essentials in any scheme of air defence, namely:—(a) intelligence, and (b) communications.

- (a) Intelligence can be treated under three headings:—
- (1) during peace, and before the beginning of an attack in war;
- (2) during an attack; (3) immediately after an attack.

Intelligence before the beginning of an attack includes information obtained during peace of all the resources of a possible enemy; his preparations and probable intentions; with the numbers, details and performances of his machines both civil and military. On such information will the whole scheme of air defence of a country and its forces in the field depend. In peace such information can be collected, compiled, and assimilated in a careful and comparatively slow manner. But directly a state of war arises, speed in the collection and transmission of that intelligence to those whom it most concerns, *i.e.* the executive in the air defence services, becomes the prominent factor. The authority responsible for the collection of that information has to add comparatively suddenly to his ordinary peace-time duties that of rapidly tracing the movements of both hostile and friendly aircraft, as by no other method can an officer check information sent to him by his observers. Only on the efficiency of the preparations made for the use of telephone, telegraph, and other signals can be hope to issue the warnings which will be required by the population to enable them to take cover during a raid. The state of war may even be heralded by the air attack itself, and there may only be a matter of a few hours for the transition from “intelligence duties during peace and before an attack” to “intelligence during an attack.”

It will be best to consider a concrete example, which will show perhaps more than anything else the necessity for speed.

Take an imaginary city with an average radius of 12 m., with its centre situated 30 m. west of the sea. One night a ship 60 m. east of that city reports a number of aeroplanes as having been heard passing high overhead, going west at an estimated ground speed of 100 m. per hour. The message, which is probably sent “in clear,” is picked up by some coastguard station, which sends it to the local senior naval officer and so to the military garrison commander near at hand. These officers, after digesting the report, and confirming it if possible, send it on through their respective headquarters to the central organ of the system. Thence it goes to the railways, to the police, and to air defence headquarters, who give the alarm to the railroad men, to the civil population, and to the squadrons, guns, and lights, etc. of the defences, respectively.

The defending squadrons will probably be situated from 15 to 20 m. from the centre of the city, *i.e.* about 40 to 45 m. from the source of the report. At the squadron aerodromes the pilots, who are waiting ready to start up the machines, “taxi” over the aerodrome, and then “take off” and begin to climb to predetermined heights, as the real height of the attack cannot be known at the moment.

A little time-table will show the time probably left to them to get up to, say, 20,000 feet.

Time taken by attack to travel 40 to 45 m. say	minutes
Ship to shore	27
Coastguard to local H.Q.	5
Local H.Q. to main H.Q.	2
Main H.Q. to Air Defence H.Q.	2
Air Defence H.Q. to units	1
Starting up machines, “taxi-ing” and taking off	5
<b>Total (say)</b>	<b>17</b>
Leaving the machines to get their heights in	10

A single report of this nature would suffice to send out an alarm far and wide, and turn the defence posts over a vast area into seething points of activity; whilst there might be nothing whatever to show that those machines were hostile, or that if hostile they were going to attack the city in question. The initial probability was that they were hostile; and as they happened to be going west at a point 70 odd miles east of the city, the time required to get the defending aeroplanes into position would leave no option but to assume that the attack was coming to that city. Yet the attack in this instance might easily turn aside as soon as the coastline was made, in order to proceed to some other objective; there was no certain indication beforehand of the real one, and there may never be.

The foregoing example shows that the observatory system of a defensive organization for a big “vulnerable point” must extend to a radius of from 70 to 100 m. from the probable main objective of hostile attack by air, if the executive is to have sufficient time to get its defences into a state of readiness for action, and the civilian population and railways properly warned of the approaching danger.

As soon as the attack enters the area in which anti-aircraft posts exist, each of such posts within sight or earshot of the attack becomes a potential source of information. It remains then for the commander of the air defences to organize a system of speedy intelligence within his own command, which can be supplemented by reports collected from police and railways, which may or may not assist in checking the reports received from the defence posts themselves. This system continues its work until such time as the attack withdraws to a point outside its boundaries, when intelligence is again required from outside sources until it is certain that the engagement is over.

Directly after the attack it becomes of importance immediately to check the commander's ideas of the battle, to supplement them with local details of what actually happened, and to compile as complete an account as possible, showing:—Nature and numbers of aircraft employed on each side; routes followed by attack and defence; casualties to personnel and material; number and nature of bombs dropped; expenditure of ammunition; size, speed, and manoeuvres of enemy machines; new features of machines, if any; efficacy of communications; weather conditions, etc. This report is of high importance and may enable a commander, if it is compiled and issued rapidly, to dispose his forces afresh in sufficient time should features in the attack show this to be necessary.

In this connexion, it is important to note certain peculiarities of air-defence information. A report on the position of aircraft *in movement* is incorrect the instant after the observation is made, unless the time of the observation is given. The value of the report decreases with every moment that elapses after the observation. To be of value at all it must specify whether the aircraft was seen or only heard; if the former, whether friendly or hostile; and the time of the observation. To be of real value, it should contain data as to the direction of flight, the number and type of the machines and their height. One of the outstanding curiosities of the air raids over England was the remarkable inaccuracy of the reports rendered by eyewitnesses which were received at the various headquarters. To men who have been in the services the hypothesis that the man “on the spot” knows what is going on and therefore knows best what should be done, will be familiar. The history of anti-aircraft operations during the war abounds with instances showing the fallacy of that hypothesis.

During the aeroplane raid of June 1917, over Sheerness, Gravesend, Wrotham, and Folkestone, two independent reports were received of an airship approaching London in broad daylight from

a point between Gravesend and Wrotham. They were the only intimations of any airship being present. One of the reports came from an officer, and one from a searchlight detachment: all had been used to seeing airships at night and knew what they were like. They were closely questioned, and there is no doubt that they were mistaken but none of them was ever shaken in his conviction that he had seen an airship.

The gun detachment at Hyde Park were threatened by an angry crowd one afternoon in June 1917, because they would not open fire on a British machine flying high overhead. An air raid was actually in progress over East Kent at the time.

Bombs were reported one night as dropping in places up and down the eastern portions of Lincolnshire and Yorkshire, but a duty officer sitting over a map in London could only trace the noises to echoes of a serious explosion which had taken place a short time before in Lancashire; so he assumed the responsibility of declining to give an alarm; he was right.

An airship was reported as visible and audible over the scene of the great Silvertown explosion in east London within a few minutes after the last explosion there had taken place; it was identified with a curious wisp of smoke which many spectators had noted in the glare of the flames. The sound of the engines was purely imaginary. Thin long clouds were frequently reported as airships on moonlight nights.

These few examples will show the unreliability of reports concerning aircraft and bring into prominence the enormous responsibility resting on the shoulders of the "duty officer" who, sitting miles away from the scene in a closed room, has to decide whether an observer really has seen or heard what he has said he did.

In making observations on the movements of large cylindrical airships, a common cause of error is due to the lack of an appreciation of the effect of perspective. An airship travelling horizontally and straight away from an observer may give the impression of falling vertically, nose downwards. An obliquely approaching airship may appear to be gaining height, and *vice versa*, although travelling at a constant height. Further, the observer on the ground is unable to assist himself by comparison of the size of the machine with other objects, the sizes of which may be familiar, placed at gradually increasing distances from him, and between himself and the airship.

The vagaries of the path of sound emanating from aircraft have proved extraordinarily deceptive. An officer accustomed to living in a shelter on a roof in the heart of London was able, while inside the hut, to detect sounds of aircraft which were quite inaudible to him when he was outside it. Local slopes and wooded country lead to confusion in the intensity and direction of the source of sound.

During the raid of May 23-4 1917 on the London area, airships were reported independently as "almost overhead" by three experienced anti-aircraft detachments in the neighbourhood of Hoddeston and Hatfield, though no airships came nearer than within 25 m. of them; the mistake was probably due to peculiar and dense cloud formations which lay over the London area at the time. During the same engagement, bombs dropped between Braintree and The Wash were reported as clearly audible from Putney Heath and south-west of it.

In a civilized country, warning of an approaching attack by air is required by both civil and military populations. Here again the organization must be based on "areas." It is not possible to decide beforehand the objective of attack by air, but it is possible to fix the degree of probability of attack on the different vulnerable points in any country. In each of such vulnerable points certain precautions are necessary, such as the evacuation of the workers from an explosive factory, the dowsing of bright lights, or the control of railway traffic. These precautionary measures take time to bring into force but it is nevertheless desirable to bring them into force only at the very last moment, in order not to delay output or cause unnecessary alarm and congestion. It becomes necessary therefore to keep a quick and careful record of the enemy aircraft movements, to divide up the country into "warning districts," and to provide a good system of distributing the warnings.

The movements of the attack are recorded by the "intelligence" system. The sizes of the warning districts depend on the speed with which the attack may move, as well as on the time required to bring the precautionary measures into force. The system of distributing the warnings will rest with those civil authorities who act as guardians of the public safety, who will probably use the civil telephone system.

Warnings and orders will normally be divided into: (a) preliminary warnings as to the approach to the area of an attack; (b) definite military orders as soon as the attack has entered the area; (c) messages cancelling (a) and (b).

As regards railways, special arrangements are necessary. Complete stoppage of railway traffic creates such disorganization that weeks may be taken to recover from it. Failure of train service causes the assembly of huge crowds of would-be passengers at railway stations, and so the formation of "vulnerable points" in which a single bomb would cause immense destruction of life. The dislocation of the traffic suspends the punctual delivery of goods, and upsets transport arrangements throughout the whole country traversed by the railway system, as well as in the ports to which it is connected. The control of the traffic therefore remains in the hands of the railway authorities, who are advised by the military authorities of the assistance the system may afford to hostile aircraft under certain circumstances. Both the railway and military authorities render each other mutual assistance in the interchange of information regarding the progress of an attack by air.

(b) *Communications.*—The rapidity with which aircraft move, and the uncertainty of their objectives, render necessary a very complete system of communications. Without such provision the intelligence gained cannot be collected or information and orders distributed in sufficient time to meet an attack before it arrives over its objective, or to enable precautionary measures for the public safety to be taken.

Signals may be sent by wire, wireless, and visual means. Means of communication are required between:—

Points on land, Ships on the sea, Machines in the air,	and	points on land, ships on the sea, machines in the air.
--	-----	--

Signal by wire is only possible between stationary points, *i.e.* those on land or the shore and anchored vessels afloat. Visual signalling between machines in the air and points on the ground is limited chiefly by atmospheric conditions, but also by the necessity of concealing the position of machines in the air. As between points on the surface of the earth, intervening ground features as well as atmospheric conditions may interfere.

In order to minimize the inevitable congestion which arises where the same wire circuit is used for the dual purpose of collecting and distributing information, independent methods must be provided for the two processes wherever this can be arranged. As far as possible information should be collected by wire circuits, but after verification it may be distributed by any method available. Wireless is of value between machines in the air to enable formation commanders to communicate with each other and with the machines under them. Wireless signal facilities are also required to enable machines to check their navigation reckonings, and to assist them in locating landing grounds, particularly when fog or cloud prevail. For the communication of intelligence before the latter has been thoroughly investigated its use is a source of danger, owing to the ease with which wireless messages can be "pecked up" and to the large proportion of inaccuracies to be found in messages concerning aircraft.

These broad principles apply to all "back" areas, but in "forward" areas, where shell fire renders the maintenance of wire circuits almost impossible, resort to wireless alone may be necessary, if the passage of aircraft intelligence is essential in the area affected. That the highest standard of accuracy and rapidity is required to make the service of communication efficient for crises in which minutes are precious goes without saying.

#### V. The Application of the Various Instruments of Defence.

In order always to be as economical as possible, air defences must not be disposed too far from the area they are intended to defend. As the attack can come from any direction, they must be disposed all round that area. To dispose ground defences along the boundary of a state with aeroplanes on patrol on either side of them, in order to keep the invader out of the state

at the outset, is to be "strong everywhere," and consequently "strong nowhere." Such a policy involves dispersion of available strength over unimportant localities, reduction of control, loss of cohesion in effort, extravagance, and the achievement of a minimum of efficiency. The close defence of the localities which are important to the state is the only sound policy.

For the defence to be effective, the attack must be met and defeated at the right height and outside the line from which it can achieve its object. Such at least must be the aim of the defence, however difficult it may be of achievement. That is to say, the defence must be outside the objective of the attack. This necessity plunges the matter at once into difficulties with what is known in the army as the "chain of command." An army works by definite boundaries shown by real or imaginary lines on the ground. The air knows no boundaries. It follows, therefore, that those units of air defence formations which are tied to the ground must be sited and organized for purposes of command with no regard to those imaginary territorial boundaries necessary to the ordinary army of the ground, and solely with regard to the whole area in which the vulnerable point or points are situated.

In one respect the sea has an important bearing on the nature of aeroplane attacks. The risk of being shot down on the return journey while still over water, with little or no hope of rescue, tends to make a circumspect pilot fly high over his objective, even if this be some distance inland, as he must evade detection till he has gained such a start over the pursuers as will enable him to pass the sea in safety even with a damaged engine. This was apparently the policy of the Germans during the raids on London in Sept. 1917. Whether, in any given case, the pilot will thus sacrifice some of the effectiveness of his attack in order to give himself better chances of a safe return, will depend on his personal character, the traditions of his corps and the free hand or limiting instructions that he receives from his superiors. From the point of view of the defence this has its drawbacks. It is difficult to decide *a priori*, or even during the progress of the attack itself, as to the probable height of the enemy when the basis of the decision is practically conjecture. Another effect of the seacoast on anti-aircraft defences may be to limit them in area. The defences must extend over an area outside the vulnerable point; but, in cases of ports on the open sea, that area is limited to the ranges of gun and searchlight on the edge which borders on the sea.

Some typical instances of the use of the various instruments of defence may now be considered. The defence has to provide against attacks both by day and by night. By day the instruments of defence and their adjuncts are: the machine-gun in the air, the heavy gun on the ground, the sound locator, and the observer post. By night the machine-gun in the air must be manned by a crew specially trained in night fighting, and in addition there is the searchlight. By day and by night the object of the defences is to break up the enemy attack and destroy it in detail. By day the massed attack must be broken up by gunfire before the aeroplanes on the defensive are launched against it; this entails guns outside the defensive aeroplane patrols, which again are outside the vulnerable point. Then in support of the aeroplanes (*i.e.* in rear of them) more guns again are required to repel such of the attackers as succeed in penetrating the aeroplane patrol area. And lastly, throughout the area of the vulnerable point itself, provision must be made for attacking by gunfire any hostile machine which may succeed in penetrating so far.

The attack will probably be audible and visible throughout the greater part of its course. In certain conditions of thick cloud or haze it may be invisible from the ground, but this fact, though increasing the difficulties, does not alter the disposition of the defences.

By night the attack is broken up in an entirely different manner. Both attacking and defending machines being in darkness, the attack is, as it were, reconnoitred by the searchlight, and the targets selected by the latter are isolated for engagement by the apparently simple process of keeping them

illuminated. Unless the searchlights succeed in their object, the attack is invisible.

It is not possible as a rule to illuminate several targets in a searchlight beam simultaneously, although during the war as many as five have been held in the beam simultaneously for a few minutes; nor is it likely that any method of illuminating a formation of, say, 22 machines simultaneously, for any length of time, would be practicable. The outer ring of guns, therefore, would normally remain inactive by night unless the absence of a defending aeroplane gives an opportunity for a gun to engage an enemy target.

By day and by night the aeroplane in defence can only move a certain maximum distance on patrol without running the risk of allowing an attack to slip past in rear of it; the aeroplane also requires a certain minimum distance on one side or other of its patrol line in which to manoeuvre and bring its enemy to battle. Suppose for the purposes of illustration these measurements be taken at 15 and 10 m. respectively. The aeroplane patrol area, and the battle and pursuit area, must be kept as clear as possible of gunfire areas and areas containing vulnerable points of any size.

The width of the gunfire area will depend on the probable height at which the attack is delivered. Assuming that the latter is 10,000 ft. and that the gun can command a horizontal range of three miles at that height, the belts of gunfire may be taken at six miles in width. Observer posts must be between 70 to 100 m. away, as has been shown, in order to gain time for the defences to get into position, if they are to meet the attack as it comes in and not bring it to account merely as it is returning home.

In the case of a vulnerable area represented by a circle of a radius of 5 m., the area immediately outside that will be a belt for gunfire from 3 to 4 m. in width; the next a belt of 10 m. for the aeroplane battle and pursuit area; then one of 6 m. for the outer gunfire area; and a final belt from 45 to 75 m. wide covered with a network of observer posts, each of which can be from 10 to 15 m. from each other. This arrangement provides for the problem of defence by day.

By night it is necessary to consider the disposition of the searchlights, and it will have been seen that one of their functions is to indicate the approximate position of attacking aircraft. To be of any value they must be able to do this throughout the vulnerable area, the adjacent gunfire area, the battle and patrol area, and for a sufficient distance outside the latter (say 4 to 5 m.) to enable the aeroplanes patrolling in defence to move into position to meet the attack. This gives the total area through which searchlights must be disposed, the projectors being at the angles of triangles whose sides measure approximately 2,500 to 3,000 yards. Owing to accidents on the ground, trees, houses, railway stations and the like, the actual distribution of searchlights throughout the area often appears to be indiscriminate; it is inadvisable as a rule to place a searchlight nearer than from 200 to 500 yd. from a gun. Again, by night, the difficulties of determining the height of the attack are so great, that it becomes necessary to dispose the aeroplanes in defence at different heights. Assuming this difference to be 1,000 ft., and that there are five machines one above the other, with the lowest at about 8,000 ft., the highest will be at 13,000 feet. The degree of endurance to be expected of a pilot flying on patrol at night may not exceed a tour of two hours in the air.

These data, combined with a knowledge of the average lengths of the summer and winter nights, will be sufficient to give some indication of the minimum numbers of machines and pilots required in the problem of night defence. The number by day is also affected by the probable frequency and size of the attacks.

It will now be easy to realize the enormous scale of defences required if any appreciable degree of efficiency is to be attained.

A simple diagram will illustrate this general disposition of defences.

Few "vulnerable points" are as symmetrical as those indicated in these diagrams, but the principle illustrated can be applied to areas of almost any shape.

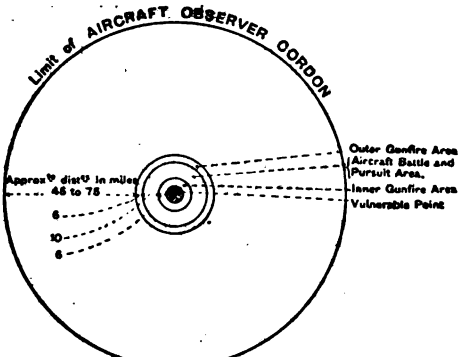

FIG. 1—Day.

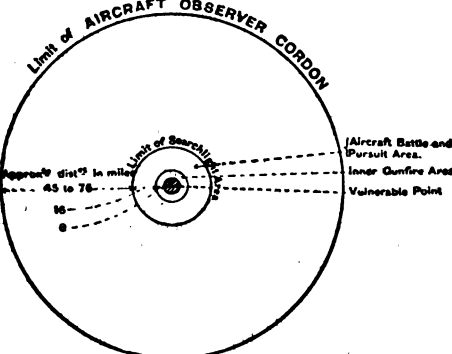

FIG. 2—Night.

By taking the maps of any state and applying these principles to the important towns, it will readily be seen that the matter is in reality considerably more complicated than it at first appears. For example, the defence area for Birmingham cannot be separated from that for Coventry. The defence of London is closely associated with that of Woolwich, and both of these are intimately linked with the defences of Gravesend and of Chatham; so that it eventually becomes necessary to look upon the whole district south of a line between the Wash and the Bristol Channel as a single area to be provided with defences under one command. Therefore this whole area will, for purposes of air defence, have an organization independent of all those ordinary commands and military formations whose activities are limited by conventional lines on a map.

The same line of reasoning applies to forces in the field with their "forward" areas, lines of communication, and bases; and necessitates the problem of air defence being considered with reference to the whole area of active operations, and not merely to that of all the independent vulnerable points within it.

The principle illustrated in the diagram will be found applicable to most cases, provided that consideration is given to the relative urgency of demands for gun and aeroplane defence combined, and of aeroplane defence alone. For the civil population, whilst applauding the courage and success of the airman, is ever apt to mingle with its praise a demand for a gun. A gun is tangible and comforting; it can be seen and heard; and so it produces on the population a moral effect which may be more than counterbalanced by the interference it may cause to the defending airmen.

An instance, already alluded to, in which the principle requires modification, is that of coastal towns and harbours, few of which can be situated geographically so as to admit of the all-round disposition of defence illustrated. Here the sea intervenes to cut off observer posts, searchlights, and guns, in addition to restricting the area of manoeuvre for the defending aeroplanes by night. This inroad into the defences offers the enemy an avenue of approach, and necessitates considerable strengthening of the batteries within range of and covering the sea in the neighbourhood. A certain amount of defence may be afforded from vessels afloat, but reliance cannot be placed on them for anything more than a temporary assistance, as they may only be present for uncertain periods.

All that can be done is to increase the intensity of the gunfire belt to seaward, and to provide aircraft detector posts and instruments with a directional value in azimuth rather than vertically. The latter serve as a partial substitute for the observer cordon by giving somewhat distant warning of the approach of aircraft.

The defence of towns and ports separated from enemy territory by sea alone thus requires maintenance in a state of instant readiness for action, and so calls for a greater complement of personnel than would be the case in defences situated inland.

The areas on either side of the dividing "line" between opposing forces in the field, up to a distance of some miles from the dividing line, were generally described during the World War as "forward" areas. The areas behind the forward areas were usually termed "back" areas; the latter term, however, was not generally taken to refer to places outside the "theatre of war," though from the point of view of aircraft action it was just as applicable.

In "forward" areas vulnerable points in the nature of men, guns, animals, and ammunition stores are numerous, but as a rule well distributed. In "back" areas they all tend to greater concentration. Protection is therefore more easily afforded in the former than in the latter, and so the better targets for bombing machines will be found as a rule in "back" areas.

The nearer the "line" the more intense will become the fire of hostile ground artillery; this precludes the free use of searchlights nearer than about 5,000 yd. from the "line," and necessitates the distribution of anti-aircraft artillery in smaller fire units than is possible at a greater range from the enemy.

Targets will be far more numerous in the forward area than in rear of it, throwing much more work on the anti-aircraft artillery situated near the line.

Applying the principle, as illustrated in the figures, to the problem in the field, a distortion of the diagram results, as in the cases of coastal towns. The outer ring of guns (Fig. 1) is formed by the guns "in the line" and such as can be spared to protect the flanks and rear of the force. Within that ring, guns will be concentrated closely around vulnerable points such as munition dumps, hospitals, etc., whilst the defending aeroplanes will patrol in the space which may be available between. The maintenance of communication between the forward guns in the shell area becomes a matter of great difficulty and may require provision of special apparatus.

By night the guns "in the line" must rest as far as possible, and employ themselves with observation duties. Searchlights in the aeroplane battle and pursuit area nearest the "line" must perforce be curtailed, and the aeroplane patrol lines withdrawn to points which will admit of sufficient searchlights operating between them and the attack.

#### VI. Some Possibilities of the Future.

Some limit to the speed of aircraft and the height at which they can fly must be assumed, and, as far as the possibilities can at present be imagined, heights up to 30,000 ft. and speeds of 200 m. per hour, together with powers of long endurance in the air, may come within the range of practicability during the next 20 years or so. A successful development of the helicopter would bring about a great change in the power of manoeuvre of aircraft, and enormously increase the difficulties of the defence. Detection of approaching aircraft will be rendered difficult by the silencing of the machinery; their destruction by fire will be hampered by the introduction of metal protection. Wireless aids to navigation will decrease the difficulties of the pilot in thick weather, improvements in the landing power and stability of machines will increase their immunity from storms; and all these conditions will call for a greater state of readiness in the defence. On the other hand, improvements in artillery will be necessary, and will follow as a natural consequence. Inventions for the detection of the locus of the source of sound will facilitate the accuracy of searchlight work. These factors, in their turn, will impose greater caution on the attack and give greater confidence to pilots patrolling in defence. Aeroplanes now used in defence will in the course of years become less localized in their work, and will develop a tendency to operate more and more like battle-fleets at sea. Such aerial fleets operating from their bases will be likely to carry their own armaments and searchlights, and to be accompanied by what we may call their "destroyer flights," which will assist them to seek out and find the enemy themselves.

The improvements which will produce this tendency will only mature gradually, and danger will lie in the endeavour of the ground or air services to assume entire responsibility for defence against air raids before being in a position to do so. There must be a long transition period during which co-operation between air and ground units must be the strongest link in the chain of



defence. Only in proportion as the air services become of a more stabilized nature, and anti-aircraft artillery improves, will the need for close co-operation diminish; it will never entirely disappear. The inability of the British navy to prevent short raids on the East Coast towns of Great Britain during the World War must not be forgotten; in like case, no country will ever be able to make good a defence against aerial raiding attack by aircraft alone. Consequently a nation must guard against exposure in the transition period to dangers which the air services or ground services of themselves alone cannot avert. Local ground defences will always be a necessity; and reliance on them will become greater owing to the many and devious paths of approach open to the enemy taken in conjunction with the reluctance of a nation to expend the huge sums necessary to provide aircraft to watch them all.

Every disease produces its own remedy; and in the end only the highest degree of excellence attainable by the arms of defence on the ground, acting independently of the units in the air, will procure the maximum of immunity for vulnerable points.

(M. St. L. S.)

**AIRD, SIR JOHN, 1ST BART (1833-1911).** British engineer, was born in London Dec. 3 1833, the only child of John Aird, contractor for gas and water plant. He joined his father's business at 18, and was entrusted with the removal of the Crystal Palace buildings from Hyde Park and their re-erection at Sydenham. He took part in many enterprises at home and abroad, such as the Hampton and Staines reservoirs, the waterworks of Amsterdam, Copenhagen, Moscow, Bahia, Pará, Calcutta, Simla and Berlin, and later (in the joint firm of Lucas & Aird, afterwards John Aird & Co.) the St. John's Wood railway, the Hull & Barnsley railway and docks, the W. Highland railway and the great Assuan dam across the Nile. He represented N. Paddington in Parliament as a Unionist from 1887 to 1905, and was its first mayor in 1900. In 1901 he was created a baronet. He made a fine collection of pictures by British painters, the illustrated catalogue to which was printed in 1884. He died at Beaconsfield, Bucks., Jan. 6 1911.

**AIR FORCES: see FLYING CORPS.**

**AIR RAIDS.**—Air-raiding by airships, and still more by aeroplanes, was carried out during the World War in most of its geographical areas. German bombers were particularly active in France, and many towns near the Rhine suffered severely in later times from the aeroplanes of the British Independent Air Force. But nowhere can the history of the continual see-saw of success between raiding and air defence during the war be studied better than in the German raids carried out over England in general and against London in particular. Their story during 1914-5, 1916, 1917 and 1918 will here be narrated.

1914-5.—Directly Great Britain came into the war, the German High Command began to encourage their public with prophecies of the havoc the Zeppelins were about to work in England. Disillusionment came quickly. The experience of some of the smaller airships, attempting to work by day over Belgium and Lorraine, was by no means encouraging. Three were destroyed at once, and it became evident that for airships to fly low in daylight over enemy territory was to invite certain disaster. Hence it was that, although reconnaissances over the North Sea towards England were begun by airships, the first actual attacks were made by aeroplanes.

In Dec. 1914 a couple of bombs were dropped in the sea off Dover, and three days later, on Dec. 24, the first German projectile hit English soil. A small bomb fell near the Castle at Dover and broke some glass. Both these aeroplane attacks were in the nature of a surprise, and the defences, such as they were in those days, could take no action. On the following day a seaplane dropped a few bombs at Sheerness, without effect. This time both the ground and aerial defences took action; but British aeroplanes came in for most of the anti-aircraft fire from the ground. A few half-hearted attacks by aeroplanes and seaplanes made during 1915 were ineffective, except that two women were killed at Margate in September.

The barren honours of the first attacks having fallen to the

aeroplane, it was left to the lighter-than-air machines to cause the first serious damage and loss. In the evening of Jan. 19 1915, two naval airships approached the coast of the eastern counties between Yarmouth and Cromer. They separated and dropped bombs on both towns. One of the raiders went out to sea again at once; the other, handled with greater boldness, proceeded to King's Lynn, dropping bombs as it went. Four people were killed, including two women, and the material damage was estimated at £7,000 or £8,000.

On April 14 the redoubtable Mathy, boldest and ablest of all German air commanders, began his activities over England. Commanding L<sub>9</sub>, a new and improved type of naval airship, he made a considerable tour over the North. On this occasion, he was not particularly successful, most of the bombs falling harmlessly in open country. At Walsall, however, he succeeded in singeing the hair of a woman who was washing a little girl by the fireside. The following night L<sub>9</sub> returned, accompanied by two other ships, and caused some damage in Suffolk. The next four raids were on a similar scale. Bury St. Edmunds was bombed in moonlight from a height of some 3,000 ft., the airship trusting to patches of fog to escape. Southend, always a favourite "fortress" for attack, suffered twice, three people being killed. On May 17 Capt. Linnarz, very active about this time in command of one of the military airships, while over Ramsgate described the lights of London, more than 50 miles away, for the first time; but his orders forbade him to go inland, and this most tempting of targets had to be left for another occasion.

The opportunity soon came. On the night of May 31 1915 Linnarz succeeded in bringing his ship over the metropolis, in reply to the Germans alleged, for a bombardment of Ludwigham-fen. This raid was carried out in full moonlight, a fact that shows how much there was to learn at the time in the art of air defence. The great size of the thickly populated area of London makes it an ideal target for promiscuous bombing. There was on this night only one raider, armed with an inefficient type of bomb, but 41 people were killed or injured, and more than £18,000 worth of damage was caused. The bombs all hit the eastern part of London north of the river; one of them fell into a tank at John Walker's whisky distillery in Whitechapel. Fortunately the tank contained water only.

Further raids in Yorkshire and Kent on June 4 had little result, but two nights later Mathy again attacked the north, this time doing much more harm than before. He found Hull, came down low over it, and killed 24 people, besides wrecking some 40 houses. The people of Hull, exasperated by this experience, broke out and smashed up a number of shops supposed to be German, but a better revenge was in store, for another airship, LZ37, that attempted to raid on the same night was totally destroyed by Lt. Warnford while it was returning home near Ghent, and fell in flames, one member only of the crew escaping alive. The first serious military damage in England was done by a single ship that raided the north on June 15. Some works in Yarrow were hit, 18 men killed and a number injured.

In commenting on the first raid on London on May 31, the Press had to come to the conclusion that it was in the nature of a trial trip, and this view was justified by the series of nine organized raids that took place in the latter part of 1915. The series opened inauspiciously for the Germans, a Zeppelin engaged in bombing Dover being hit by a new 3-in. gun that had just been mounted there. She struggled across the Channel, losing gas rapidly, and fell into the sea near Ostend, where she was finished off by bombing aeroplanes.

London was reached on four nights during this period. Twice the results attained serious proportions. On Sept. 8 Mathy, now in command of L13, an improved type of Zeppelin, came in over the Wash, steered straight on London and bombed the City deliberately and with considerable success. Fires broke out in many places, and the damage done amounted to more than £900,000. Mathy also took part in the raid of Oct. 13, when his ship bombed Woolwich. On this occasion the casualties were 71 killed and 128 wounded. These losses were severe enough, but they were nothing to what the German public was led to

believe; it was during this time that many of the airship commanders began lying freely, and "bombing" places they never went near.

The anti-aircraft defences had not yet been able to take the measure of the attack, and the good shooting of the Dover gun, mentioned above, was the solitary success that can be claimed for the ground defences up to the end of 1915. A few aeroplanes had been allotted to home defence, but they were quite unsuited for their task on account of their poor climbing power and their inefficient armament. The pilots, also, had but little training, and night landing grounds were few and very far between, so that accidents during 1915 for the attack of airships led in nearly all cases to fatal or serious injury to British pilots, and the attempt was looked on as a forelorn hope.

1916.—The defences could do no better in the early raids of 1916. Nine Zeppelins manoeuvred over the Midlands on the last night of January, one getting nearly to Shrewsbury. Seventy people were killed. Out of 16 British aeroplanes that went up in pursuit, 3 crashed on landing. A month later 2 airships were able to sit over Hull and bomb it from a low height, without any interference from the defence. From this time, however, defence took an upward turn; the change for the better began to show about the beginning of April 1916 during the very next series of raids. L15, one of the five ships that attacked on March 31 1916, in attempting to reach Woolwich, was hit by the gun at Purfleet; it was then attacked in the air by Lt. Brandon, eventually falling into the sea off the coast of Essex. Mathy's ship was hit by a shell on the same night, but he managed to struggle home.

A wholesome dread of defended areas now began to be observable in the German tactics. For instance, during the last raid of this April series, Hull was undoubtedly saved from further bombing by some new guns just installed there.

Fifteen airship flights were made over England and Scotland during this April period. Elinburgh was bombed with little effect; nothing came over London, although some bombs were dropped as near as Waltham Abbey. British losses were 84 killed during the series.

Further raids at the end of April were organized in conjunction with the naval bombardment of Lowestoft and Yarmouth, the whole operation being timed to coincide with the rebellion in Ireland. A large number of airships took part, but the result was small. London was saved from bombing by its defences on April 25. One Zeppelin ran out of petrol and was eventually destroyed on the coast of Norway.

The shortness of the summer nights prevented further raids until the end of July, when four attacks were delivered, indicating an ever-increasing respect for the defences. Twenty flights over England produced infinitesimal results, if we except the loss, at Hull, of 10 lives. An abortive raid on Harwich was followed on Aug. 24 by an attack on London by Mathy, now in command of L31, a new Super-Zeppelin; he showed his usual dash, skillfully avoiding the defences by making use of clouds. He threw several 240-lb. bombs, the largest then known; they caused a few casualties and considerable damage in southeast London and round about Blackheath. The raid of Sept. 2 was carried out by 14 ships and was a determined attempt on London. The metropolis was undoubtedly saved by the brilliant action of Lt. Robinson of the R.F.C., who did not hesitate to attack the military airship SL11, although she was under very heavy gunfire at the time. As he fired his third drum of ammunition into her, she burst into flames and fell, a burning mass, near Cuffley. The sight of this disaster was too much for the other commanders, who turned tail and made the best of their way home. British casualties included only three killed.

The next series of raids, begun on Sept. 23 1916, was of great importance. The German command were not deterred by previous losses from again risking their best airships and pilots in the attack of London. They conceived, not unreasonably, that if London could be terrorized, they might touch the moral of the British Government, and so produce an appreciable effect on the conduct of the war. On Sept. 23 1916 the weather conditions over the North Sea were favourable for raiding. Eleven

airships left German sheds, nine crossed the British coasts, and the main attack was directed on London by three of the newest Super-Zeppelins, coming in from the east and south-east.

Having crossed the Essex coast shortly before 11 P.M., L33 was over east London ten minutes after midnight. Here she dropped twenty bombs. London, however, was no longer the helpless mass of former days. The searchlights continually lit up the hull of the airship, which was at 12,000 ft.; she was badly holed by the guns, one of her engines was damaged, and she began to lose gas and fly clumsily. To add to her miseries, Brandon of the R.F.C. now brought his machine close up to her. For twenty minutes he stuck to her, pumping bullets into the fabric. As she laboured back towards the North Sea, the crew threw out everything they could lay their hands on, including the machine-guns. Her commander crossed the coast at Mersea Island, going out due east. But the certainty that his ship would fall into the sea was too much for him; he turned her about and came to earth three miles inland at Wiggborough, near Colchester. A specimen of the latest type of Zeppelin thus fell nearly intact into British hands.

Mathy meanwhile brought his ship L31 in company with L32 up the English Channel and, turning in over the Kent coast, made straight for south London. On the way he dropped a few trial bombs to test his sighting. Approaching the defences, he handled his ship with great skill and succeeded in blinding some of the British searchlights, that were picking him up, by throwing out powerful illuminating flares. He passed straight over the centre of London, crossing the Thames near London Bridge. South London and the extreme north suffered severely; but, for some reason, Mathy threw no bombs in the central districts, where he could have done most damage. He got clear away this time, and went out to sea by Yarmouth. The handling of the companion ship, L32, was not of nearly so bold a character. Her commander began to hesitate as soon as he had crossed the coast of Kent, and he spent an hour circling about Romney Marshes. When eventually he started N. for London his courage again failed, and he kept edging off to the E. so as to avoid the central defences. His caution could not save him. As he crossed the Thames near Dartford he was picked up by lights and attacked by guns. In order to rise he dropped most of his bombs in open country. His efforts were of no avail. Brandon, who was still in the air, describes the ill-fated ship as being "hosed with a stream of fire." This was the attack delivered by Lt. Sowrey, also of the R.F.C., who succeeded in setting the ship on fire in several places; she fell in a mass of flames at Billericay, in Essex. The British casualties on this night were 21 killed, including one aeroplane pilot. The enemy would hardly see in this adequate return for the loss of two new airships with their crews.

On the night of Sept. 25 four ships raided the north, bombing Sheffield, where 29 people were killed, and narrowly missed Manchester. Two other ships, whose commanders had already become noted for their caution, came up to the Norfolk coast but would not cross it. Mathy, on this occasion, took his ship on an entirely new line. Passing through the Straits of Dover, he flew up the Channel as far as the Isle of Wight, where he turned N. and went straight over Portsmouth. He dropped no bombs on the fortress or dockyard. Near Hastings he went to sea again on what was to be his last voyage to Germany.

Yet another serious attempt to bomb London was made on the night of Oct. 1. Eleven ships started from Germany. Three of them made an innocuous tour over Lincolnshire. Mathy in L31 came in over Lowestoft about 8 P.M. and as usual steered an excellent course on London. Soon after passing Chelmsford, however, he found that the outer defences on that side of the capital were ready for him. A searchlight picked him up. He therefore turned and steered N.E. for some 15 minutes. Turning again he flew S.W., in order to get into position for his favourite dash down wind over the city. After drifting a few moments towards Ware, he set his engines going and started for north London at full speed. Suddenly a heavy gunfire was opened on him, and he decided to abandon his attempt. He threw out all his bombs, at the same moment executing a very

remarkable right-hand turn that must nearly have broken the back of his ship. The pursuing aeroplanes were close upon him. He did all that was humanly possible to save his ship. He tried flying towards the W. on a zigzag course, rising and falling, in order to escape from the lights that continually held him, and from pilots who would not be shaken off. An airship once caught in such toils has little chance of escape. The end came quickly, Lt. Tempest came up to the ship at 12,700 ft. and brought her down in flames at Potter's Bar. Thus perished Mathy, the bravest and most skilful, as well as the most successful, of all the German commanders. The fall of Mathy's ship had an immediate effect on three other raiders, who all made a sharp turn for home the moment they saw it. After his victory, Tempest crashed on landing at North Weald Bassett, but was unhurt. During the whole of this great raid the only British loss was one man killed. The defence of London had now definitely got the better of the lighter-than-air attack; after this period no German airship ever flew intentionally over the metropolis.

Deterred by the victory of the London defences, the German command turned their attention to the north for the final effort of 1916. They met with no better success. Of the ten ships that left Germany in the course of Nov. 27, eight came over land. One was destroyed on the coast near Hartlepool before midnight by Pyott of the R.F.C. She fell blazing into the sea. Although the pilot dived away at once to avoid the flaming mass, his face was scorched by the heat as she fell.

Another raider, L21, after a remarkable journey right across England to Cheshire, was caught in the early morning just as it was growing light, when she was leaving the coast at Yarmouth. Three British naval aeroplanes came up with her. Cadbury attacked first, but exhausted all his ammunition; his experience was destined to be useful to him on a subsequent occasion. Another pilot then tried, but his gun was frozen up and jammed. The third pilot, Pulling, then went right in to within 60 ft. of the ship, under a heavy fire from her machine-guns, and succeeded in setting her alight. It is a curious fact that machine-gun fire was kept up from the gondolas for a considerable time after the hull had begun to burn. She fell into the sea from 8,000 ft. and sank at once.

Other raiders, seeing the disaster near Hartlepool, turned for home again without attacking. Those who came in over land found that the ground defences were very different from what they had expected. The guns and lights were successful in keeping the raiders off their targets. The British losses were one man and three women killed.

During 1916 eighteen raids were made on England by aeroplanes and seaplanes. They were nearly all of the "tip and run" variety, and consisted in coming over the coastline, dropping a few bombs haphazard and getting away as soon as possible. The attacks were delivered with no apparent military purpose, and they had practically no effect.

The first aeroplane attack on London was made on Nov. 28 1916 by a single machine; the weather was misty and the first intimation was the fall of six small bombs between Brompton Road and Victoria station. The raiding machine had an engine failure on the return journey and was forced to land within the Allied lines near Boulogne. Lt. Ilges, the pilot, had set out to take photographs and bomb the Admiralty.

Before the beginning of 1917 the defences had quite definitely beaten the attack, so far as concerned operations by airships against London. Over the rest of England the airship commanders were tending more and more to avoid defended places, consequently the damage they could do was limited to objectives of secondary importance. It is a significant fact that of the nine Zeppelin commanders who attacked in Jan. 1916 three had been killed and two others taken prisoner, their five ships being destroyed by the action of the defences, before the end of the year.

1917.—The three airship raids of the first half of 1917, carried out under the conditions indicated above, produced little result other than the loss of two of the raiders, one being shot down while on the way home by a French gun near Compiègne, the other being destroyed by one of the defending aeroplanes near Harwich. On the night of May 6-7 a single German aeroplane

appeared over the East End of London, and dropped a few small bombs. The attack, in itself, was unimportant, but it afforded an indication of what might come later.

Before the end of 1916 it had become evident to the German command that, if effective bombing was to be kept up on targets that were worth attacking, it would be necessary to try new methods. Early in 1917, therefore, they began equipping a squadron with special machines suitable for bombing England systematically. This formation, known as the 3rd Bombing Squadron, was distributed in aerodromes about Ghent, roughly 170 m. from London. The new machines, of the Gotha type, were capable of flying with a full load of bombs at 12,000 ft. and over. They carried a crew of three, pilot and two machine gunners. In May 1917 the squadron was ready for action, and as soon as the weather became favourable the attacks were to begin. The raids, with the exception of two minor attacks on Harwich, were aimed at London, but on the first two occasions unsuitable weather caused a failure, and the bombs were unloaded in other places.

The first attempt on London came on May 25 1917. The 3rd Bombing Squadron, 16 machines strong, left Belgium early in the afternoon and made the Essex coast about 5 P.M. On the Continent the sky was generally clear but there were thick banks of cloud over Essex. The task of navigating to London was found too difficult and the leader had to give up the attempt. He therefore turned S. over Essex and crossed the Thames about Gravesend, afterwards making a course S.E. Bombs were dropped on the Canadian camp at Shorncliffe, where there were 100 casualties. The worst effect was produced in Folkestone itself. One bomb fell in a crowded street and killed 33 people, mostly women who were out shopping. Over England the opposition to the raid was entirely without effect, but one raider was brought down in the sea by a British machine working from Dunkirk.

The second unsuccessful attempt was made on June 5; 18 machines, practically the full strength of the 3rd Squadron at that time, left the Ghent aerodromes about 2 P.M. They made the Essex coast as on the previous occasion, but this time they turned S. earlier. They bombed Sheerness with some effect, the town and dockyard both being hit several times. The guns at Sheerness succeeded in hitting one of the raiders, which fell into the river off Barton's Point. A large number of machines went up in pursuit. They were nearly all too slow and climbed too badly to do any good.

The third attempt on London was more successful. The whole of the 3rd Squadron started in the morning of June 13, taking the same course across the North Sea as before. A few machines were detached to bomb Margate and Shoeburyness. Probably this was done to confuse the defence arrangements. The main formation of 14 machines held on N. of the river to London, which was reached a little before noon. A few bombs were dropped in the East End and near the Royal Albert Docks; then, at a signal from the leader, the formation loosed 72 bombs over a small area having Liverpool Street station as its centre. The station itself was hit by three bombs. The casualties were severe—159 killed and 424 injured. One 100-lb. bomb hit a school in Poplar. On striking the building the bomb was torn in half before the fuse acted, and only half the charge exploded; even so, 27 of the children were killed. A few isolated attacks were made on the raiders without success. One machine got into touch with the enemy over Ilford, but the observer, Capt. Keevil, was killed and the pilot's gun jammed. Such gunfire as was brought to bear in the London area was badly directed and had no effect.

The next raid on London on July 7 was also successful. Twenty-four machines started; they were first seen well out to sea soon after 9 in the morning, flying at about 10,000 feet. Coming up to the coast, two machines were detached, as on the previous occasion, in order to attack Margate, where a couple of houses were wrecked. The main body of 22 machines, flying in diamond formation, crossed the Essex coast near the mouth of the Crouch river about 9.45 A.M., and they came on towards London,

gradually climbing, until they were about 13,000 ft. over Brentwood. The course of the raid ran by Enfield, where the formation turned S., over Edmonton and Tottenham. On the way to the City, St. Pancras and Shoreditch were bombed. The City itself received 26 bombs, one of them starting a small fire in the General Post Office.

The German formation was well handled in the way of making it a difficult target for the anti-aircraft guns. The machines flew in two divisions, which drew apart as they came under fire. The majority of the shell fired into the brown of the enemy burst harmlessly in the interval thus left. Individual machines flew with a switchback movement, alternately diving and climbing in order to make the task of prediction at the guns more difficult. The anti-aircraft guns fired a very large number of rounds, but produced no effect at all on the enemy. The aeroplane defences again showed a lamentable lack of plan. Eighty-seven machines went up, of all sorts and sizes. A few were efficient fighting machines. Many of them, for all the good they could do, need never have left the ground. No scheme existed by which a combined attack could be delivered. In consequence, the enemy were quite well able to beat off such isolated, though gallant, attacks as were made. They brought down two machines. All that the British pilots were able to accomplish was to finish off one lame duck, a machine that was in difficulties from engine trouble. It fell into the sea off the coast of Essex and the crew were drowned.

The failure of the defensive arrangements, or rather the complete lack of efficient arrangements, began to cause considerable agitation in the public mind. The Germans were touching the nerve centre, and the British Government found it necessary to order a complete reorganization. The London Air Defences were to be formed as a separate command. It was to include all the means of defence, both from the ground and in the air. General Ashmore was brought from France to take charge. On the formation of this new command several distinct problems presented themselves. Night raids on London by airships, although not very likely, were still possible; it was obvious that night raiding by aeroplanes would have to be faced. But the most threatening danger lay, for the moment, in day raiding by aeroplanes in force. To meet this, a line of guns was established to the E. of London some 20 m. out; and inside this line strong patrols of aeroplanes, working in formation, were organized. Careful plans were laid to ensure that the guns and aeroplanes would really co-operate and not interfere with each other. A system of signals and directing arrows on the ground was installed to assist the pilots in finding the enemy. Outer patrols of aeroplanes near the coast could deal with the homeward journey of the raiders.

The new arrangements were soon tested; on Aug. 12 a party of nine Gothas made the land near Harwich. After following the coast to the Blackwater, they turned inland for London. The communication system of the defence control worked well, and the squadrons immediately defending London were at the required height in plenty of time to meet the enemy formation. The German commander, however, would not face the defences of London itself, and turned his formation about before they reached the outer line of guns. A number of bombs were unloaded on Southend as the enemy made off, and 32 people were killed. The Germans were pursued out to sea, but an exasperating series of gun-jams robbed the British pilots of success, and the only bag was one Gocha that was flying badly and was brought down in the sea by a naval machine.

An attempt on Aug. 18 was frustrated by bad weather. Many of the German machines were blown over Holland, where some of the pilots, thinking they were over England, dropped bombs!

An abortive attack on the Midlands by eight airships on the night of Aug. 21 was followed by the last day attack on England on Aug. 22, when Capt. Kleime, commander of the 3rd Squadron, started out with 13 Gothas to bomb Sheerness and Dover. A number of naval machines turned the Sheerness bombers from their objective, and the German formation, harassed by the British pilots, wheeled south by Ramsgate. Here the anti-aircraft guns, working with great accuracy, shot down two of the raiders. A third was shot down off Dover.

The increased efficiency of the defences, both in machines and guns, decided the Germans to abandon day attacks, and they

turned their attention to raiding with aeroplanes by night. Practically no answer had been found at the time to this form of attack, which had been carried on for more than a year on the western front in France. Searchlight staffs, in their then state of training, found great difficulty in picking up or holding an aeroplane in their beams. Gunfire, which could only be aimed roughly in the direction of the enemy, was so inaccurate as to be negligible. It was not thought possible to fly during darkness fast scout machines of sufficient climb and performance. Furthermore, it must be remembered that a pilot in the air at night can only see another machine when he is close to it, and that the noise of his own engine deafens him to other sounds. At the time there was no way in which the pilot could receive information from the ground. For these reasons it seemed difficult to find any means on which to base plans of defence against night aeroplane raiding.

The first group of night attacks came in the beginning of Sept. 1917, and one of these reached London itself. The raid on Sept. 2 was a quick affair at Dover and of little importance. On the following night, Sept. 3-4, about 10:30, hostile aeroplanes were reported near the North Foreland, and warnings were sent out by the central control a few minutes later when it was clear that they were coming up the Thames. Unfortunately there was serious telephone delay in getting the warning out at Chatham, and before cover could be taken a bomb had fallen on a drill hall in which a large number of naval ratings were asleep. No fewer than 130 were killed and 88 wounded.

Although on this night the defence was ineffective, certain points emerged which gave hope for the future. Three stout-hearted pilots went up in Camels, fast scout machines, and found that it was by no means impossible to handle them at night. In fact, being small and light, they were even easier to land than heavier machines, which would run on longer on the ground. The idea also was evolved of barrage fire, a curtain of bursting shell to be put up in the path of the raiders.

The last raid of this moon period, on Sept. 4, reached London. The attacking machines, between 20 and 30 in number, began to come up to the coast soon after 10 P.M. While isolated attacks were made on Dover and Margate the majority of the raiders made for London. The barrage fire, organized since the previous night, turned some of the pilots, but 10 raiders reached the metropolitan area, and bombs were dropped in widely separated localities. The City, Paddington, Stratford, Hornsey, Holloway and Regent's Park, all suffered. One bomb narrowly missed Cleopatra's Needle. Considering the magnitude of the raid, the damage caused was small, and the total casualties for the night included only nine killed.

Favourable weather and good moon conditions at the end of Sept. and beginning of Oct. 1917 produced a sustained series of raids, opening on the night of Sept. 24th with an attack on London by aeroplanes, in conjunction with an airship raid on Hull and the north.

The first aeroplanes were reported approaching Kent as early as 7 P.M., and by 8:10 P.M. some 21 machines in seven groups had come over the coasts of Kent, Essex and Suffolk. Dover was heavily attacked, the gas-works were hit and several houses were damaged. Nine at least of the pilots attempted to attack London itself, but considerable improvement had by this time been effected in putting up barrage fire, which was successful in turning back all but three of the attackers. Of these three, one dropped bombs about Deptford and Poplar, doing but little damage; the other two passed right over London from north to south. A bomb dropped in Southampton Row killed 13 people who had not taken proper cover; others fell near the Ritz Hotel and into the river opposite the Houses of Parliament. Although 27 English machines went up they failed to find any of the enemy; the gunfire brought down one of the Gothas, which fell in the river near Sheerness.

The attack on the north was carried out by 10 airships under Capt. Strasser. After concentrating off Flamborough Head six of them came over land. Although Hull was found, the raid had very little success. This was partly owing to the cloudy

weather that prevailed. But the main reason for the failure is traceable to the gradual improvement of the defences, which had driven the airships higher and higher on each successive raid. On this occasion none of them flew under 16,000 ft. while over the land. At this height the difficulties of navigation are greatly increased and the probability of successful bombing diminishes.

On the following night, Sept. 25, 10 aeroplanes attacked. Of the three that approached London, one was turned off by the barrage fire; the other two, coming in from the S., did a little damage in Camberwell, Southwark, and Bermondsey, where nine people were killed. The barrage fire at Dover was particularly successful on this night, and the attack on that place completely failed.

The attacks were continued on the 28th, when some 20 machines came over; the night was cloudy and a few only approached London; they were all kept off by the barrage fire.

The barrage was again singularly effective on the following night, Sept. 29. Out of the 18 or 19 machines that came over only four penetrated far enough to bomb London. Of the remainder a large number were turned back by the fire put up by the outer ring of London guns. The Dover guns again did well, keeping off attack and bringing one of the enemy down in flames. Thirty defending pilots went up on this night; none of them found the enemy, although one was so close to a German machine that the anti-aircraft guns had to stop firing on it.

On the next night, Sept. 30, the German pilots showed more pluck; of 25 that attacked, eight got over London and bombed places as far apart as Highgate, Edmondton and Woolwich. Considering their numbers, they were singularly unlucky in the results: six people were injured and the damage was under £8,000.

The last raid of the series on Oct. 1 was made by about 18 machines; a few penetrated the defences and dropped bombs. One attacked Highbury, damaging a large number of houses; another bombed Hyde Park and the neighbourhood. One bomb fell into the Serpentine, killing most of the fish there. Only one British pilot saw anything of the hostile machines.

During these raids a large proportion of the attackers had been turned before reaching their target. The defences had done fairly well, but they were still far from complete. The outer ring of guns was not installed on the W. of London, and it was plain that the German pilots were feeling round by the N. for this gap.

The barrage fire was expensive in ammunition and there was a doubt if the supply could be kept up. Doubts had even arisen as to the use of the barrage—one Cabinet minister describing it as "self-bombardment." A few casualties from the gunfire were inevitable until people realized that even the lightest cover would protect them from the fragments of high-explosive shell. In spite of casualties, however, it was plain that the public looked upon the barrage fire as a comfort. It is significant that a Christmas fund got up by the *Star* newspaper for the men working at the guns had to be closed down from over-subscription.

Progress had already been made in night flying, on fast machines, but the defending squadrons had not nearly reached the necessary efficiency in machines or pilots.

The "Aprons," a new defence devised after the raid of Sept. 5, were only beginning to be installed. These were screens of wire that could be raised to 10,000 ft. by Caquot balloons, and were designed to limit the range of heights in which the defending pilots would have to seek the bombers. The Central Control as organized in Sept. 1917 could give no information to pilots when once they had been sent on their patrols, but schemes to rectify this had already been initiated. On the whole, although the attack at this time had the best of it, there were reasonable hopes that this condition would not last much longer.

The airship raid of the night Oct. 19-20 1917, which became known in London as the "silent raid," has points of special interest. The weather conditions were the dominating feature both as regards the attack and the defence.

Eleven airships met on the evening of the 19th off the Yorkshire coast for an attack on the industrial centres of the Midlands.

To avoid gunfire and aeroplane attack while over England, the ships flew at an immense height, well over 16,000 ft. At this altitude the efficiency of the crew is much impaired by height sickness and the intense cold. Another and fatal condition was produced by the weather. Near the ground the air was misty and there was very little wind, but at the height of the airships a strong gale was blowing from the N., and in this the Zeppelins drifted blindly S., the navigators being prevented by the ground mists from correcting their course. One airship passed over London without recognizing it and dropped a few heavy bombs; one of 50 kgm. fell in Piccadilly outside Swan & Edgar's shop and caused some casualties. Owing to the peculiar conditions of the night, sound carried very badly, and this ship crossed London unheard. Eight other airships, in the course of their southern drift, passed, without knowing it, within easy reach of the metropolis.

Realizing that, on account of the ground mists, searchlights would have no chance of lighting up a high Zeppelin, the defence ordered them to remain covered unless an airship could be heard. The London public were inclined to complain that the usual display of lights and barrage fire was lacking. The lights, had they been turned on, must have produced the worst results. They could not light up the enemy, but they would be sufficient to show the attackers where London was, and to enable them to correct their course for drift. As it was, London was saved from a combined attack and the raid ended in disaster to the attackers.

One airship only returned to Germany in the usual way; six got back after flying over Holland or across the Allied lines. The remaining four were destroyed during the following day on French territory.

Aeroplane raiding was resumed during the moon period at the end of October. An attempt on the 29th failed on account of bad weather; another on the 31st was carried out by 24 machines. Considering that a good many of them got over London, the effect was small—one woman killed and damage to the extent of about £23,000.

The weather in Dec. 1917 was generally unfavourable for long-distance raiding, and only three attempts were made on London. The defences showed steady improvement. Two Gothas were brought down by anti-aircraft gunfire during a raid in the early morning of Dec. 6 on which occasion the Germans lost a third machine in the sea on the way home. On the night of the 18th, improvements in the searchlight control and the special training of the night-flying pilots began to make themselves felt. Twenty-seven defending machines of the best performance went up, and three combats took place.

As a result, one of the Gothas was so damaged that it fell into the sea off Folkestone and was destroyed. On this night the new "Giant" aeroplane came over London for the first time. It dropped one 300-kgm. bomb in Lyall Street, near Eaton Square, making a large crater but doing little serious damage. The whole raid, however, cost London more than £300,000 in damage.

On Dec. 22 the last raid of the year was frustrated by unfavourable weather; one Gotha was forced by engine trouble to descend near Margate, where it was destroyed by the crew.

1918.—In the five aeroplane raids of the first quarter of 1918 there was a tendency to replace the smaller Gotha machines by the new "Giants." A Gotha was destroyed by a defending aeroplane on Jan. 28. During this raid a bomb dropped by a Giant fell on a building in Long Acre that was being used as an air-raid shelter, and 38 people were killed.

On the following night, Jan. 29, one of the Giant machines was pursued half round London by four of the defending scouts. The reason for its escape is curious. The British pilots saw over their sights a machine they imagined to be of Gotha size. The actual machine, being a Giant and very much larger, was therefore a good deal farther off than they thought, and they were firing at too long a range to be effective. The crew of the Giant became panic-stricken and were within an ace of landing when the British machines drew off.

Three Giants, unaccompanied by any smaller machines, attacked on Feb. 16; the only one that penetrated to Lon-

don demolished a house in Chelsea Hospital with a 300-kgm. bomb.

The raid of March 7 1918 was remarkable as being the only occasion on which aeroplanes attacked London in the absence of any moonlight. The navigators of the attacking Giants were helped by a bright aurora. This made the night unusually light, and gave a constant bearing of fair accuracy to the pole. Warrington Crescent was badly hit, most of the houses being wrecked.

To turn to the airships, the disaster of Oct. 19-20 1917 was followed by the destruction of four more ships by explosion in their sheds, and raiding was not resumed until the nights of March 12 and 13 1918. Both these raids were made at an immense height, and although Hull and West Hartlepool were bombed, the damage did not amount to much. The casualties comprised nine killed on the two nights.

Five airships of the newest and largest type, under Capt. Strasser, attacked the Midlands on the night of April 12. Although more than seven tons of bombs were dropped in the neighbourhood of big towns, the result was very small, and only five people were killed.

The end of the airship raiding came on Aug. 5-6 1918. Five ships came up to the coast of Norfolk, no bombs were dropped on land, but L70, the latest word in airship construction, was destroyed, with Capt. Strasser on board, by Major Cadbury, flying a DH4 machine.

In the great aeroplane raid of May 19 1918 the Germans made their maximum effort in this form of attack; between 30 and 40 Gothas of the 3rd Bombing Squadron took part, with at least two Giant machines. Thirteen of the raiders managed to get over London. The casualties included 49 killed, and £130,000 worth of damage was done in the London area alone. But the defence had by now made very real progress. Eighty-four aeroplanes, nearly all of excellent performance, went up in pursuit, and all landed safely. The anti-aircraft guns fired upwards of 30,000 rounds. The plans worked well in that the defending pilots were assisted instead of being hampered by the gunfire and searchlights. The Germans lost seven machines—three shot down in air combat, three destroyed by gunfire, and one from engine failure.

This success of the defence was final, and London was saved from further bombing. The Germans turned their attention to Paris, which now sustained a long series of raids.

A new system of defence control was in course of being installed in London at this time, but it did not come into full operation until Aug., and it was therefore never tested in an actual raid. It provided a method by which the defence commander could follow the course of raiding machines, and could instantly transmit information and orders to the pilots in the air by wireless telephone. It was calculated that this system would increase the power of the defence at least fourfold.

A proof of the efficiency of defence by aeroplanes, assisted by a good organization on the ground, was furnished by a squadron, manned by pilots trained in the London methods, that was sent to France in June 1918 to cope with night bombing near the line. In a very short time they accounted for 26 German machines, and they practically stopped bombing in their area, with no loss to themselves.

**Conclusion.**—We have now traced the way in which raiding and defence grew up together, and the eventual success of adequately equipped and organized defences. In addition to casualties—1,413 killed, 3,407 injured in all—and damage, the German raids on England produced actual results by no means negligible. A night raid stopped munition work over a large area. In order to establish a defence, men and material were kept back from France. This was particularly felt in the case of aeroplanes and pilots. Two hundred aeroplanes of the best performance and 200 highly trained pilots were available about London at a time when they would have been of the utmost value on the western front. The moral effect of raiding is found to depend not so much on actual damage as on the success or ill-success of defensive measures. In London, the barrage, the

“aprons,” and the aeroplane defence did much to allay fears that had arisen when there was apparently no answer to the attacks. (E. B. A.)

**AIRSHIP:** see AERONAUTICS.

**AITKEN, JOHN** (1839-1919), British physicist, was born at Falkirk Sept. 18 1839. He was educated at Falkirk grammar school and Glasgow University, and trained as marine engineer at R. Napier & Sons, Glasgow. He lived at Falkirk, where he carried out his great experiments on atmospheric dust in relation to the formation of clouds and mists (1882), on the formation of dew (1885, see 8.136) and on the laws of cyclones (1891). His instrument for counting the dust particles in the air (see 8.714, 18.279) has been utilized in principle by many later workers. He also invented new forms of thermometer screens and powerfully aided the development of meteorology. He was elected F.R.S. in 1889 and was awarded the Royal medal in 1917. He also received the Keith medal (1886) and Gunning prize (1897) from the Royal Society of Edinburgh, in whose *Transactions and Proceedings* most of his valuable contributions were published. He died at Falkirk Nov. 14 1919.

**AKHWAN MOVEMENT**, a religious revival or reform, confined mostly to the Nejd districts of Arabia. The term *akhwan*, or *ikhwan*, signifies “brethren,” and the tenets of the brotherhood are those of Wahabism revived and intensified (see 28.245). The movement, recognized by Ibn Sa'ud, Emir of Nejd, had taken definite shape after 1910; and in 1921 it still seemed likely to have far-reaching effects upon the attitude of the people of Central Arabia towards other Arabian communities and even to the outer world.

**ALABAMA** (see 1.459).—In 1920 the pop. was 2,348,174 as against 2,138,093, in 1910, an increase of 210,081, or 9.8 %, as compared with 309,396, or 16.3 %, in the preceding decade. Although the proportion of urban pop. was greater than in 1910, yet in spite of the marked development of mining and manufacturing interests, more than three-fourths of the inhabitants were still rural and chiefly agricultural. The urban pop. (inhabitants of cities of 2,500 or more) was 509,317; the rural, 1,838,857. The growth of pop. in the chief cities is shown in the following table:—

	1920	1910	Increase per cent.
Birmingham . . . .	178,270	132,685	34.4
Mobile . . . . .	60,151	51,521	16.8
Montgomery . . . .	43,464	38,136	14.0
Bessemer . . . . .	18,674	10,864	71.9
Anniston . . . . .	17,734	12,794	38.6
Selma . . . . .	15,607	13,649	14.2

The distribution of pop. by race was as follows: whites, 1,447,032; negroes, 900,652; Indians, 405; Chinese, 59; Japanese, 18; all others, 8. During the decade 1910-20 the white pop. increased 17.8 %, while the negro pop. decreased 0.8 %, due to male negro migration to northern industrial centres.

**Agriculture.**—There were 256,099 farms in 1920; 262,001 in 1910, a decrease due to the negro migration noted above, but there was a marked increase in total production. The State Department of Agriculture estimated that in 1920 there were harvested 5,630,000 tons of commodities compared with 5,203,000 tons for the year 1910. The same department made the following estimates of the acreage, production and value of crops in 1920:—

Crops	Acres	Production	Value
Corn . . . . .	4,277,000	67,234,000 bus.	\$67,057,000
Cotton . . . . .	2,868,000	660,000 bales	53,515,000
Cottonseed . . . . .	—	296,700 tons	7,339,000
Peanuts . . . . .	409,700	9,024,000 bus.	5,936,000
Hay . . . . .	1,410,000	3,324,000 tons	27,123,000
Velvet beans . . . . .	743,700	440,100 tons	7,914,000
Cowpeas . . . . .	532,200	5,113,000 bus.	9,622,000
Irish potatoes . . . . .	47,900	3,215,000 bus.	11,250,000
Sweet potatoes . . . . .	179,800	17,585,000 bus.	16,939,000
Sorghum syrup . . . . .	99,900	8,917,000 gal.	8,340,000
Sugar-cane syrup . . . . .	59,700	10,298,000 gal.	10,643,000
Oats . . . . .	366,000	6,813,000 bus.	6,740,000
Wheat . . . . .	68,000	680,000 bus.	1,594,000
Soy beans . . . . .	23,000	227,000 bus.	588,000
Tobacco . . . . .	3,000	2,100,000 lb.	420,000
Total harvested	11,117,900		\$235,520,000

The above estimates did not include the acreage grazed or "hogged" and not harvested, which the state department of Agriculture placed in 1920 at 1,344,000 ac. with an approximate value of \$20,001,000. The Statistical Bureau of the U.S. Department of Agriculture estimated the value of all crops in Alabama in the year 1920 at \$240,000,000.

**Industries and Transportation.**—Three new lines of material progress during 1910-20 were notable: (1) The use of hydro-electric power; (2) shipbuilding; and (3) the utilization of the canalized Warrior and Tombigby rivers from the heart of the inland mineral district to tidewater at Mobile. A private corporation completed a great dam across the Coosa river and was in 1920 delivering electricity for lighting and power purposes to the chief centres of population and industry in northern and central Alabama; and the same company in 1921 began another great dam across the same river which would increase greatly the power available. In the meantime the U.S. Government undertook the famous "Wilson dam" across the Tennessee river at Muscle Shoals. The impetus given to shipbuilding at Mobile continued after the World War; and the great shipyard at Chickasaw, a suburb of Mobile, was in 1920 steadily sending down the ways ships of heavy tonnage, made from steel fabricated in the Birmingham district and barged down the Warrior and Tombigby rivers. The growth of down-stream tonnage of coal, iron, steel and timber on the canalized Warrior river continued for a year or two under private enterprise; but the closing months of the year 1920 marked a new era when the first vessel of a fleet of Government-owned and -operated self-propelling barges made its way down the Mississippi river to New Orleans and into the Gulf, then to Mobile and up the rivers to Birmingham and Cordova in the heart of the Warrior coal-fields. A balanced tonnage, up and down stream, was steadily being developed in 1921 by the transhipment at Mobile of manganese ore from Brazil, for use in making high-grade steel in the Birmingham district, and by the establishment of an all-water freight rate from New York and other eastern points, via Mobile, to the various river ports.

**Mineral Production.**—The Geological Survey of Alabama reported a decrease in 1918, as compared with the preceding year, in quantity but an increase in value of most of the mineral products of the state. In 1918 the production of coal was 19,184,962 short tons valued at \$54,752,329, with a coke production of 4,892,589 short tons valued at \$28,394,272. The iron ore mined in 1918 amounted to 6,121,087 long tons with an estimated value of \$15,334,561; the gross tons of pig-iron marketed amounted to 2,645,179, valued at \$80,893,678. Another important mineral product was graphite, of the crystalline variety, the value of which in 1918 was \$999,152 as compared with \$719,375 in 1917. It is estimated that Alabama furnished over 60% of the domestic graphite used in the World War.

**Education.**—The impetus given to public education, under the administration of Governor Comer (1907-11) by the creation of a system of county high schools and by more liberal appropriations both for the common schools and for the institutions of higher education, lost none of its momentum under his successors. In the beginning of Governor Kilby's administration the Legislature passed an Act, approved Feb. 6 1919, creating a commission of five members, appointed by the governor, to make a study of the educational system of the state with the object of determining its efficiency. The commission in turn urged the U.S. Bureau of Education to accept the task. The result was a series of Acts passed by the Legislature in 1919, constituting the School Code of Alabama. Among the most important of these Acts was one providing for a state Council of Education to coordinate the efforts of the university of Alabama at Tuscaloosa, the Alabama Polytechnic Institute at Auburn, and the Alabama Technical Institute and College for women at Montevallo, by assigning to each special fields for higher education. The efficiency of the public-school system of the state was perhaps best shown by the steady reduction of illiteracy. The total number of illiterates in 1920 was 278,082, of which number 210,690 were negroes, 65,394 native whites, and 1,893 foreign-born whites. During the two-year period between the school censuses of 1918 and 1920, the percentage of literates in the total population, white and negro, between the ages of 10 and 21 years, increased 5.2 per cent.

**Taxation and Finance.**—Owing to the limitation in the constitution of 1901 of the rate of state taxation upon real and personal property to 0.65% upon assessed values, the Legislature in 1919, in an effort to increase revenues, incorporated in the general revenue bill among the license or privilege taxes a tax of two cents per ton on coal and three cents per ton on iron mined in the state, payable

monthly. At the same session a graduated income tax, ranging from 2% to 4% was levied; but the Supreme Court decided that it was repugnant to the constitution and null and void. By a decision of the Supreme Court handed down Feb. 13 1921, the amendment to the constitution hereafter noted, authorizing the issue of \$25,000,000 highway improvement bonds, was declared to have been irregularly adopted and not a part of the constitution; but as the decision was rendered by a divided bench of four judges to three, an application for a rehearing was pending, and if not granted, an effort was to be made to have the amendment re-submitted for adoption according to the strict terms of the constitution by an extra called session of the Legislature.

**History.**—During the period from 1910 to 1921 the Government of Alabama remained in the control of the Democratic party, with little more than nominal opposition by the Republican party, the educational, property and other qualifications for voters under the state constitution of 1901 having eliminated the bulk of the negro Republican voters. It was only in the presidential election of 1920 that there were indications of the development of a real white Republican party in the state. In that election that party polled practically one-third of the vote cast, 31.9%, thus securing the privilege of a primary for the nomination of candidates in the next election at the expense of the state Government. Before this time factional differences in the Democratic party were fought out in the primary elections under state supervision, and the general elections were merely formal ratifications of the choice made in the primaries. It was not easy to distinguish clearly between the two leading factions that developed in the dominant party, but perhaps the terms "Conservative" and "Progressive" sufficiently indicate the line of cleavage. The former insisted on the fullest protection to vested financial interests, and before the adoption of the Eighteenth (prohibition) Amendment to the Constitution of the United States, on a liberal policy of "local option" in the manufacture and sale of alcoholic beverages. The latter stood generally for strict control, by the state, of corporate capital, especially in the matter of railway rate regulation, and for prohibition of the liquor traffic. Several amendments to the state constitution of 1901 were adopted during this period, most of them dealing with matters of local interest to counties and cities. Two, however, were general in their scope: one providing for local option by counties and school districts as to increased taxation in the interest of public schools; the other authorizing the issue of state bonds to the amount of \$25,000,000 for the construction of a complete system of highways, thus enabling the state to secure the national appropriations in aid of that policy. At its regular session in 1919 the state Legislature refused to ratify the Nineteenth Amendment to the Constitution of the United States providing for woman suffrage; but as soon as the requisite number of states had made it a part of the Constitution, Governor Kilby called a special session of the Legislature (1920), which promptly passed an Act providing for the registration of women voters and for otherwise carrying into effect the provisions of the Amendment.

The total number of men enlisted for the World War in the state and inducted into the army was 73,811. As this did not include National Guard commands or other volunteers, the Alabama Department of Archives and History estimated that approximately 10% should be added. Alabama subscribed a total of \$99,838,400 to the Liberty and Victory Loans.

Recent governors were Braxton B. Comer (Dem.), 1907-11; Emmet O'Neal (Dem.), 1911-5; Charles Henderson (Dem.), 1915-9; Thomas E. Kilby (Dem.), 1919- (T. C. McC.)

**ÅLAND ISLANDS** (see 1.469).—The alarm that had been felt in Sweden for some years at Russia's projected military works in the Åland Is. was intensified in 1915 when Russia openly began the construction of fortifications. Sweden protested against this breach of the Convention of Paris (1856), and Russia's assurance that the fortifications were merely temporary did not allay Swedish hostility towards Russia which at times threatened a crisis. The Russian revolution of 1917 diverted attention from the fortifications to the larger question of the sovereignty of the islands. In Aug. 1917 the Åland islanders took steps to consider reunion with Sweden, and as a plebiscite in Dec. showed 95% of the population in favour of the proposal, a petition to that effect was presented to the King of Sweden in Feb. 1918. The King in reply echoed the hope of the deputation that a solution of their desires might be found "in concert with free and independent Finland." In the same month Sweden sent a military expedition to the islands to protect the population from outrages by the Russian Bolshevik garrison with which a small Finnish White force was unable to cope. The Russians were sent to Åbo and the Finnish troops to northern Finland via Sweden. On the arrival early in March of German troops by invitation of the Finnish Whites, the Swedish force withdrew. The German garrison remained until Oct.



1918. The Treaty of Brest-Litovsk (March 3 1918) and the subsequent treaty between Germany and Finland (March 7 1918) both stipulated that the fortifications on the islands should be removed and not subsequently rebuilt. But the work of demolition was repeatedly delayed. The Finnish Government opposed the Ålanders' wish for union with Sweden, but proposed to compromise by making the islands into a separate Finnish province. The Diet persisted in this policy, and passed a bill for self-government for Åland in May 1920. Meanwhile the appointment of a Finnish military governor caused resentment, which was aggravated (July 1918) by attempts to call the Ålanders for military service on the mainland. They refused to obey, at the same time expressing their willingness to serve in the islands under Swedish-speaking officers. Many of the inhabitants fled to Sweden in order to escape service. In Nov. 1918 the Ålanders appealed to the United States, Great Britain, France and Italy, relying on the right of self-determination. An appeal to Finland at the same time drew an equivocal reply. In Feb. 1919 the Ålanders submitted their case to the Supreme Council in Paris. Sweden supported their claim. The Peace Conference declined to deal with the matter, which was then referred to the League of Nations. A commission of three jurists appointed by the League reported (Sept. 1920) that the Council of the League was competent to make recommendations since the dispute did not refer to a matter left by international law to the domestic jurisdiction of Finland. The League thereupon appointed a commission to examine the question.

Opinion in Finland among both Finns and Swedes was strongly opposed to the cession of the islands, and it was argued that to yield to the demand for self-determination of a fraction of the Swedish population of Finland (about one-tenth) would be to reduce the doctrine to an absurdity. At the same time the opposition of the Swedes in Finland to the Ålanders' desire might be regarded as biased by unwillingness to lose the weight of their vote and so lessen Swedish influence in Finland. Finland also maintained that her sovereign rights over Åland were not affected by Russian domination in Finland or by subsequent events, and that Finland was not one of the "new" states that arose as a result of the World War; and that in consequence the Åland question was purely a domestic one in which no other state nor the League of Nations was competent to intervene. On the other hand the Ålanders showed themselves virtually unanimous in their desire for union with Sweden, to which they were closely allied in race, language and to a great extent in trade, and they maintained that their islands were sufficiently distinct from Finland geographically to give them the right of self-determination.

The commission, after visiting Stockholm, Helsingfors, and the Åland Is., presented its report to the Council of the League at its session in June 1921. On June 24 the Council announced its decision that the islands were to belong to Finland, but that they were to be neutralized from a military point of view and given full guarantees of unfettered autonomy. M. Branting, on behalf of Sweden, said Sweden would bow to the League's ruling under protest, and M. Hymans was appointed to preside at a committee of Finns and Swedes to discuss details of the guarantees.

For a general account of the islands reference may be made to Handbooks prepared under the direction of the Historical Section of the Foreign Office, No. 48, *Åland Islands*; also *Allor da Finlande*, with text in French (1910). The Finnish side of the present dispute is set forth in *The Åland Question and the Rights of Finland* (1920). See also Sven Tunberg, *Les Îles d'Åland dans l'Histoire* (1919), and E. Sjaestedt, *La Question des Îles d'Åland* (1919).

(R. N. R. B.)

**ALASKA** (see 1.472).—The most important events in the history of Alaska in the ten years ending with 1920 were:—(1) the extension of surveys and investigations of resources over nearly half of the total area (586,400 sq. m.); (2) the change

Most of the inland surveys and investigations, as well as a part of those made along the shore line, were done by the U.S. Geological Survey, which between 1910 and 1920 mapped about 50,000 sq. miles. The Coast and Geodetic Survey charted the general

in the public land policy, which no longer prohibited the utilization of Alaska's coal, petroleum and water powers; (3) the granting of a measure of home rule to the people of Alaska; (4) the improvement of transportation by the construction of a Government railway from an open port on the Pacific to navigable waters on the Yukon river, by the construction of many wagon roads (total roads and trails 4,900 m.) and by the installation of many lights and other aids to navigation (total 547); and (5) the great advance of her copper and salmon-fishing industries, and of gold mining until 1916.

*Public Land Policy.*—The political history of Alaska has largely centred in a struggle for more liberal land laws. In early days it had been considered for the best interests of Alaska to transfer the lands to private ownership as quickly as possible without too close a scrutiny of the means employed. This policy was completely reversed as a result of the conservation movement inaugurated under President Roosevelt. The aim of the movement, as first defined, was to prevent waste of natural resources; but this issue proving too academic to make a popular appeal, it gradually veered to a protest against corporate control of lands and resources. Though supported in the beginning by the best element in the nation, it ultimately became involved in the bitter struggle between the Roosevelt and Taft wings of the Republican party. As practically all the lands of the Territory were still owned by the Government, the withholding of the most valuable of these from settlement and development played havoc with her industries. Curiously enough, the most ardent of the conservationists failed to recognize the urgent importance of conserving the salmon and halibut fisheries. As it was, the withdrawal of coal, oil and good timber lands as well as of water powers left the Territory with only metalliferous deposits and fisheries on which to base its industries. A very important by-product of the conservation movement was the development at Washington of a mania for the establishment of reservations in Alaska. In this way there were set aside for various purposes, exclusive of mineral or forest withdrawals, some 40,000 sq. miles. For many years the Alaska conservation issue remained at a deadlock between the executive and legislative branches of the Government. Meanwhile Alaskan industries languished. With an abundant supply of fuel close at hand, she was forced to import coal and petroleum at great cost; her pulp wood was rotting in the forest, her water powers were undeveloped. Only gold- and copper-mining and salmon-fishing increased. Finally during the Wilson administration a leasing policy for coal and oil lands and water powers was established by law. At about the same time the shortage of paper had a liberalizing influence on the regulations relating to the sale of timber from the national forest. In 1921 the new laws were too recent to allow an estimate of their effect.

*Government.*—The struggle of Alaska to attain representation in Washington, lasting nearly 40 years, resulted in 1906 in the authorization of an elected delegate to Congress. At each biennial election which followed, home rule was the only important issue, until finally in 1912 an Act was passed granting a territorial government. This continued the governor as a presidential appointee, and (unwisely, though in accord with American tradition) provided for a bi-cameral Legislature. The upper chamber, or Senate, consisted of two senators from each of the four judicial districts, serving four years. Sixteen representatives formed the lower chamber, or House of Representatives, four elected for two years from each judicial district. This equal representation for each of the judicial districts gave the less-populated areas of the interior an unjust preponderance in the Legislature, and in many instances worked against the best interests of the Territory as a whole. Congress in the organic Act expressly retained the right of repealing all laws enacted by the Alaska Legislature. Furthermore, the Territory was denied the right to enact laws relating to the excise, game, fish, fur-

features along the entire coast-line and covered about 10% of it in detailed surveys of important harbours and principal routes of navigation. In 1913 the International Boundary Commission completed the survey of the Alaska-Canadian boundary.

bearing animals, or the existing Federal licence tax. It was provided that the capital should be at Juneau. The first session of the territorial Legislature was in March 1913, and the first law passed gave the franchise to women. Since that date the most important legislation has related to mining, hours of labour, workmen's compensation, banking and education. Heavy taxes were also imposed on the salmon-fishing industry, and from these the Territory derived a large part of its income. In 1916 the Legislature authorized a plebiscite on the prohibition of the sale, transportation and manufacture of all alcoholic beverages. The vote was in the affirmative by 7,958 to 4,431. As the Legislature had no power to change the excise law, a petition was submitted to Congress, which passed a dry law for Alaska in 1917.

**Education.**—The white schools of Alaska were in 1920 under territorial management and were supported by local taxes. Even most of the small settlements had schools, and five of the larger towns supported high schools. The Territory founded an agricultural and mining college at Fairbanks in 1918, but as funds were appropriated only for the erection of a building, the school had not been opened up to 1920. In 1919 there were 62 white schools in the Territory, with 147 teachers and 2,713 pupils. The education of Alaskan Indians and Eskimos was in the hands of Federal agencies. In 1919 there were in the Territory 70 Indian schools, too few to accommodate the children of the 25,000 natives. The Federal Government also made some provision for medical service for the natives, and maintained six small hospitals for the purpose. In addition to the Government schools, about 35 sectarian missions were maintained by various churches for the benefit of the natives. Many of these had boarding-schools and a few had hospitals.

**Population.**—In 1920 the pop. was 54,899, a decrease of 9,457, or 14.7%, from 64,356 in 1910. The whites numbered 29,000, as against 36,400 in 1910; the Indians and Eskimos 25,000, as against 25,331 in 1910; and the balance was of Mongolian and other races. Juneau, the capital and an important mining centre, was the largest town, with a pop. of 3,058. Ketchikan, the most important fishing centre, had 2,458. Anchorage and Seward, on the Government railway, had respectively 1,685 and 652. Cordova, the coastal terminus of the Copper River railroad, had 955. Fairbanks, the chief mining town of the interior, had 1,155. Nome, on the Seward peninsula, had 852. The white population of Alaska steadily increased until 1915, when it exceeded 40,000. Subsequent losses were due to—(1) enrolment in military service of about 3,500 men, few of whom returned; (2) high wages in the States; and (3) decrease in the gold-mining industry. While in 1915 about 9,600 men were employed in Alaska mines, there were only about 3,000 in 1920. In addition to the permanent residents of Alaska, between 25,000 and 30,000 men annually visit the Territory to find employment, chiefly in fishing, but also in mining. There were also 2,000 or 3,000 tourists each summer.

**Mountaineering.**—The mountain ranges include a number of the highest peaks on the continent, which have exercised a fascination for the mountaineer. Many unsuccessful attempts were made to reach the summit of Mt. St. Elias (18,024 ft.) before the Italian Duke of the Abruzzi finally succeeded in 1897. Mount Wrangell, Alaska's highest volcano (14,005 ft.), was ascended by Robert Dunn in 1908; and in 1912 Dora Keen climbed Mt. Blackburn (16,140 ft.). Several attempts were made between 1903 and 1910 to climb Mt. McKinley, the highest peak in North America. William Taylor and Peter Anderson, prospectors, reached the summit of the N. peak (20,000 ft.) in 1910, and Hudson Stuck and Harry P. Karsten the summit of the S. peak (20,300 ft.) in 1912. Katmai volcano, in the central part of the Alaska peninsula, had been entirely dormant for more than a century previous to 1912. On June 6 of that year, without previous warning, the top of the volcano blew off and ejecta were thrown for at least 1,500 m., while the fine volcanic dust encircled the world in the upper atmosphere. Though one of the greatest eruptions in historic times, it caused no loss of life, because the ejecta fell chiefly on the sea and in uninhabited regions.

**Railways.**—At the close of 1910 there were 371 m. of railway in Alaska. This included 20 m. of the White Pass Railroad (narrow gauge) which ran inland from Seward across the international boundary to White Horse in the Canadian Yukon (110 miles). This line, while primarily serving Canadian territory, gave access during the open season of navigation to the settlements on the lower Yukon. The Copper River & North-Western Railroad (standard gauge),

extending from Cordova on the coast to the Chitina copper belt (196 m.), was completed in 1910. Another line, the Alaska Northern Railroad (standard gauge), was built for 71 m. from the town of Seward, and then went into bankruptcy. A narrow-gauge railway 45 m. in length, connecting the town of Fairbanks with the gold-mines, was completed in 1904, and was later purchased by the Government. About 130 m. of railway were laid in various parts of the Seward peninsula and subsequently abandoned. In 1912 Congress authorized a special commission to report upon the Alaska railway situation. The commission recommended that 733 m. of railway be built, estimated to cost \$35,000,000. The project included two lines: one to extend from Cordova to Fairbanks, using the Copper River railroad, with a branch to the Bering River coal-field; the other to run from Seward (utilizing the existing stub line) through the lower Susitna valley to navigable waters of the Kuskokwim river, with a branch into the Matanuska coal-field. In 1914 authorization for not more than 1,000 m. of railway construction, the cost limited to \$35,000,000, was granted by Congress. A new commission was then appointed, and after extensive surveys was confirmed in general the former estimate of cost. In 1915 the administration announced the selection of a railway route from Seward to Fairbanks. The estimated cost of this was about twice as much as for the route from Cordova to Fairbanks. Railway construction was begun in 1916, and by 1920 383 m. out of a total of 467 m. had been completed. The entire system was to be finished by 1923. The choice of the more expensive route and a policy of using only construction of the highest type brought the cost, at war prices, up to \$52,000,000, with a probability that it would cost several millions more.

**Commerce.**—The value of the total products of Alaska from the annexation in 1867 to the close of 1920 was about \$1,000,000,000. In 1919 Alaska produced minerals, furs, fish, etc., to the value of \$71,000,000. During the same year the value of her imports was \$38,925,000, of which \$1,449,000 was for merchandise from foreign countries. In 1919 25 American vessels (tonnage 32,444) and 3 Canadian vessels (tonnage 4,870) were operated as common carriers to Alaska ports. These carried 295,490 tons of freight and 32,803 passengers northbound, and 278,200 tons of freight and 31,717 passengers southbound. In the same year 378 private vessels (tonnage 118,169), chiefly engaged in fisheries, were operated in the Alaska service and carried a total of 465,000 tons of freight (north- and southbound). Nine river steamers were operated on the Yukon in the summer of 1919. These carried a total of 9,600 tons of freight and 1,370 through-passengers. One steamer was operated on the Kuskokwim river in 1919.

**Mining.**—From its small beginning at Juneau in 1880 up to the close of 1920 Alaska mining yielded a total value of \$460,000,000. Of this 96% is to be credited to gold and copper deposits. But the mines have also produced silver, platinum, palladium, tin, lead, antimony, tungsten, chromite, coal, petroleum, marble, gypsum, graphite, barite and sulphur; and development work was done on deposits carrying nickel, iron and molybdenite. The value of the total annual mineral production rose from \$16,800,000 in 1910 to \$22,000,000 in 1920. Alaska mines have produced \$320,000,000 worth of gold, of which \$220,000,000 is to be credited to the placers. The largest gold production of any one year (1906) was \$22,000,000. Since 1916, when the value of the gold output was \$17,200,000, gold-mining has steadily declined, being only \$8,000,000 in 1920. This decrease was due to the world-wide stagnation of gold-mines caused by the economic conditions brought on by the World War, and to this primarily is due the loss of population already referred to. In the past about 60% of Alaska's population has directly or indirectly been supported by the gold-mining industry. The U.S. Geological Survey estimated the value of the placer gold reserves of Alaska to be at least \$360,000,000. This was in addition to the gold in vein deposits whose value could not be estimated. Auriferous lodes have been found in many parts of Alaska and developed in a small way. The only large gold lode mines were in south-eastern Alaska. Before the war there were near Juneau a number of large gold-mining enterprises operated at a lower cost than any others in the world. The small profits per ton were offset by the very large tonnage of ore. With the increased cost of labour and supplies mining greatly decreased at Juneau. Alaska copper-mining began in 1901, and up to the close of 1920 had produced 308,000 tons of metallic copper, valued at \$127,000,000. Stimulated by the war demand and high prices, the mines made their largest output of copper in 1916 (59,900 tons). In 1920 the Territory produced 35,000 tons of copper, chiefly from four large mines. Copper ores are widely distributed in Alaska, but most of the deposits are as yet inaccessible. The richest copper-mines thus far developed were those of the famous Kennicott group in the Chitina district. There are high-grade bituminous coals and some anthracite in both the Bering River and Matanuska fields, the latter within reach of the Government railway. All Alaska coal lands were withdrawn from entry in 1906, and patent was refused to all but a few claims previously entered. This interdiction lasted until 1913, when a coal-leasing law was enacted. Coal-mining was still in the development stage in 1921, the entire production up to that time being only 300,000 tons. The output of 1920 was 70,000 tons, chiefly taken from a Government mine in the Matanuska field. The total

estimated reserves of coal in the surveyed fields of Alaska were 19,590,000,000 tons, of which 12,610,000,000 tons were lignite. Oil seepages were found at four localities on the Pacific seaboard: namely, Yakataga, Katalla, Iniskin Bay and Cold Bay, and also at several places near the N. Arctic coast. Only at Katalla, 60 m. E. of Cordova, was there any considerable drilling; here there was some oil production from the only petroleum claim to which patent had been granted. The withdrawal in 1911 of oil lands from entry stopped all development. In 1919 an oil leasing law was passed, and the development of producing fields was expected to follow. The total Alaska oil production to the close of 1920 was 60,000 barrels. Meanwhile, the Territory was consuming about 5,000,000 barrels of imported petroleum products annually. The only considerable production of tin in North America was from the York district on Bering Sea, near Cape Prince of Wales. A total of 1,000 tons of metallic tin had been mined since operations began in 1900. Alaska had produced in all about 9,800,000 oz. of silver and 5,000 tons of lead. This had practically all been won from gold and copper ores, for no large deposits of silver and lead had been developed. The mining of platinum and related minerals began in 1916, since which time about 1,500 oz. of those minerals had been produced. Demands of the World War led to the mining of some antimony, tungsten and chromite ores, but with the decreased value of these metals after the peace these operations ceased. Quicksilver mining had been carried on in a small way for many years. There were in south-eastern Alaska extensive deposits of high-grade marble which had been quarried on a large scale.

**Fisheries.**—The total value of fish products which had been marketed (1867-1919) was \$418,000,000. In 1919 the output of the fisheries brought in \$50,282,000, of which \$45,000,000 was for salmon. Two small salmon canneries were built in Alaska in 1919; by 1919 the number had grown to 254. The fishing industry in 1919 employed 28,500 persons, of which 3,875 were Indians. Ninety per cent were engaged in salmon canning. The canneries can be operated during only from two to four months of the year, and much the larger part of the labour is imported. About 90% of the salmon caught in Alaskan waters are canned. In 1911 a total of 44,000,000 salmon were caught in Alaskan waters. This was increased in 1918 to 101,500,000, but fell to 58,000,000 in 1919. The enormous catch of 1918 was due to the stimulus of the war demands, and was undoubtedly in excess of the number that can be taken without permanently impairing the industry. In the early days of the salmon-fishing there were no restrictions, but, beginning in 1902, laws were passed to regulate the fisheries. The latest law (1906) was a great improvement on those preceding, but is by no means adequate. As an additional precautionary measure, hatcheries were established. There were five of these operated in 1919, at which were hatched and liberated 95,580,000 young salmon. In theory this should suffice to provide for the annual catch, but in practice only a small part survive as adult fish. The importance to the nation of conserving the Alaska salmon fisheries is indicated by the fact that in 1919 a total of 133,680,000 lb. of salmon were shipped from the Territory. The halibut fisheries are being depleted even more rapidly than the salmon. About 1,000,000 lb. are caught in Alaska and adjacent waters each year. The industry employs about 900 men and 90 small vessels. The halibut is all shipped fresh; much of it to the E. coast markets, and some to Europe. The number of cod on the Alaska cod banks is enormous, but as yet they have been little exploited. The total annual catch is between 10 and 11 million pounds, and the number of men employed is only a few hundred. Herring are found in great abundance as far north as Bering Strait. Whale-fishing along the coast, once a very important industry, is now limited to a few shore stations, where the catch is chiefly utilized for making fertilizer. There has been some canning of crabs and clams. The Alaska crab, which is the same species as that found in the Pacific waters farther south, is especially delicious.

**Forest Products.**—The national forests of Alaska include all the best timber lands (total area 20,000,000 acres). These are estimated to contain 77,000,000,000 ft. (B.M.) of timber suitable for lumber and pulp. Up to 1921 these forests had been used almost solely for local use, though some spruce had been exported for the manufacture of aeroplanes and other articles which require great toughness of fibre. It was officially estimated that these forests were capable of furnishing 2,000,000 cords of pulp-wood annually. A pulp-wood industry was developed in south-eastern Alaska in 1920.

**Agriculture.**—Alaska contains extensive farm lands adapted to raising the hardier varieties of wheat, oats, barley, rye, potatoes and other hardy vegetables, and forage crops. The most promising agricultural fields were in the Tanana and Susitna valleys, both tributary to the Government railroad. Tests in this region showed that sugar beets can be matured that contain a high percentage of sugar. Extensive areas of agricultural land are also found in other parts of the Yukon basin, and smaller patches here and there in the Pacific coastal region. The best-developed farming area was in the neighbourhood of Fairbanks, where about 2,000 acres of land were under cultivation. Here a hardy variety of wheat was matured during five successive years, and part of the flour for local consumption was made in a small mill. There is an abundance of good grazing land in the interior, but the period of winter-feeding is about eight months. Up to 1921 the only cattle introduced were small

herds used for dairying. The Government recently began the experiment of introducing yaks into this region. The domesticated reindeer herds numbered in 1920 92,933 valued at \$2,238,562 against 22,407 in 1910. This was the natural increase from the original 1,200 imported by the Government between 1802 and 1902. About 70% of the herd was owned by the Eskimo, for whose support the animals were first imported. Some reindeer meat had been exported, and the amount promised to increase.

**Fur Industry.**—Between 1867 and 1920 Alaska produced furs to the value of \$90,400,000, of which \$53,000,000 represents seal skins taken on the Pribilof Is. in Bering Sea. Up to 1910 the Government leased the seal-catching privileges on the Pribilof Is. to private corporations, which killed 2,320,028 seal and paid the Government \$9,474,000 in royalties. The land killing of seal was properly restricted, but pelagic sealing by vessels of various nationalities destroyed an additional 976,000 seal. Pelagic sealing, being on the high seas, could not be controlled by the American Government; therefore a treaty was signed in 1911 between the United States, Great Britain, Russia and Japan, abolishing it and providing that the United States was to pay to Great Britain and Japan each 15% of the catch made on the islands. Since 1910 killing has been prohibited on the Pribilof Is. except by Federal agents. Thanks to these provisions, the seal herd has increased from 215,000 in 1912 to 524,000 in 1919. In the latter year the Government sold 19,157 dressed seal skins, for which \$1,501,600 was received. The value of all furs shipped in 1919, besides the seal, was \$1,500,000, of which over half is to be credited to the fox. Fur farming increased rapidly during the World War owing chiefly to the high value of furs. Most of the successful farms are on small islands, and practically all are devoted to the raising of foxes, though attempts have been made to raise both mink and martens.

See Maj.-Gen. A. W. Greely, *Handbook of Alaska* (1909); *Annual Reports of Governor of Alaska* (1910-20); Reports of 13th and 14th Census; *Report of the International Boundary Commission between the United States and Canada: Arctic Ocean to Mt. St. Elias*, with atlas (State Department, Washington, D. C., 1918); *Railway Routes in Alaska: Report of Alaska Railroad Commission* (1913); *Report of the Alaska Engineering Commission* (1916); Alfred H. Brooks, "The Development of Alaska by Government Railroads," *Quarterly Journal of Economics*, vol. xxviii. (1912); *Information about Alaska* (Interior Department, 1917); J. L. McPherson, *Alaska: Our Frontier Wonderland* (Seattle Chamber of Commerce, 1921); Alfred H. Brooks, *The Mt. McKinley Region* (U.S. Geological Survey, 1911); *Mountain Exploration in Alaska* (American Alpine Club, 1914); Hudson Stuck, *The Ascent of Denali* (Mt. McKinley) (1914); *A Winter Circuit of our Arctic Coast* (1920); Ernest de K. Leflingwell, *The Canning River Region, Northern Alaska* (U.S. Geological Survey, 1919). See also the reports of U.S. Geological Survey of U.S. Department of Agriculture, of Commissioner of Fisheries, Annual Report of Commissioner of Education, Reports of Governor of Alaska (Washington, D.C.), and of Commissioner of Education for Territory of Alaska (Juneau, Alaska).

(A. H. BR.)

**ALBANIA** (see 1.481).—Up to 1903 the policy adopted by the national Albanian leaders may be summarized as follows:—

(1) To preserve the Ottoman Empire until such time as the Albanian national ideal, surreptitiously propagated by the various national societies resident abroad, had entered into the consciousness of the Albanian people as a whole (a process necessarily slow where 99% of the population was illiterate and in the face of the opposition of both 'Abdul Hamid and the Greek Patriarchate)—lest a premature disruption of Turkey might bring about the dismemberment of Albania herself at the hands of her Christian neighbours; (2) to press in the meantime by constitutional means for an autonomous administration of Albania.

Prominent among those in favour of these Fabian tactics were Ferid Pasha Vlorë, the Sultan's trusted grand vizier, and his cousin Ismael Kemal. The keen appreciation by these statesmen of their country's predicament was amply proved by subsequent events. These events, however, they were unable to control. In July 1908 the Young Turk revolution became imminent. The Albanian mountain chiefs, throwing in their lot with the revolutionary movement, took the lead by telegraphing to the Sultan to demand the revival of the constitution of 1878. A few days later Maj. Enver Bey and the Committee of Union and Progress proclaimed the constitution at various places in Macedonia, and the II. and III. Army Corps threatened to march upon Constantinople. On July 24 the Sultan bowed to the inevitable. Six months later he was deposed after his attempt at counter-revolution had failed—an attempt undertaken with the aid of his Albanian bodyguard and with the

countenance of the Liberal union, headed by Ismail Kemal, who had already realized that the aims of the committee were little more liberal than the old régime's. The privilege of informing him of this decision of Parliament was reserved for another Albanian, Essad Pasha.

The Albanians had at first hailed the Turkish revolution with enthusiasm. It seemed to promise the fulfilment of their most cherished aspirations: autonomy and the introduction of means of education in the national tongue. Albanians had never been slow to avail themselves of any opportunity of educating themselves on national lines, as is proved by the phenomenal progress in education that had been made within Albania itself during the years 1879-86, when the establishment of Albanian schools was tolerated, as well as in the Albanian colonies abroad. The names of men like the brothers Sami and Naim Frasheri, the first a lexicographer and historian, the second a poet; of Wassa Pasha, founder of the society for the publication of Albanian books in Constantinople in 1879; and of Prenk Dochi, who became Abbot of the Mirditi in 1888, should especially be remembered in connexion with the obscure but heroic efforts on the part of patriotic Albanians to educate their countrymen prior to the revolution of 1908.

A "Beas" (pledge of honour) was taken by the mountain tribesmen to suspend all existing blood feuds in honour of the auspicious occasion. It soon became evident, however, that not only was nothing to be hoped for from the Young Turks but that the triumph of the revolutionary movement was to prove a more formidable menace to the cause of Albanian nationality than the obscurantist tyranny of the Sultan. The Committee of Union and Progress had no sooner obtained a settlement of the international questions arising out of the annexation of Bosnia-Herzegovina and of Eastern Rumelia by Austria-Hungary and Bulgaria respectively, than they actively set to work to achieve their plan of Ottomanizing the subject races of Turkey. The Albanian schools, which had recently been able to open their doors through private contributions, were again closed, the Albanian newspapers were again forced to migrate to foreign lands, and the national movement was stopped. In the face of violent protests a decree was issued that the Albanian language might be taught with the Turkish instead of Latin characters and a number of school-books were actually published in this manner. But the Albanians saw through the device and would have none of it. Heaps of the books were burned in the market-places.

*Insurrection of 1911-2.*—At the same time an insurrectionary movement broke out among the Moslem tribes in the north, headed by Isa Boletin, a natural leader of rare prowess who rallied the mountain tribesmen disaffected by the attempt of the Young Turks to levy taxation from which hitherto they had been exempt. The Turks, however, retaliated by ruthless efforts to disarm the population. Whole villages were destroyed and what the proud clansmen would less easily forgive—their chiefs were publicly flogged. In 1911 the insurrection assumed larger dimensions. While the Moslem tribes kept quiet the Roman Catholic Malizia and Mathe tribes, instigated by the Montenegrins, formed armed bands, and in the spring attacked with success the Turkish outposts on the Montenegrin frontier. In April Torgut Shevket Pasha tried to suppress the movement with a large army, but notwithstanding the superiority of his forces, met with several reverses. In May Russia warned the Ottoman Government not to extend hostilities against Montenegro, who was harbouring a large number of the refugees. In June Mirdita joined the rebels, proclaiming her own autonomy and setting up a provisional government. In the same month there was a great meeting of rebel chiefs, who drew up a statement of their grievances and a list of their demands under 12 headings, of which the most important were the recognition of Albanian nationality and the use of the Albanian language in the schools and in all local administration.

*Balkan War, 1912-3.*—The Turks attempted to bribe and cajole Mgr. Sereggi, Archbishop of Scutari, a brave and honest patriot, to intervene. He protested that he had not the authority;

nor was it his business. The inevitable result was that the following year, when the Turks were fully engaged in the war with Italy, the insurrection broke out afresh. The Albanians of Kossovo joined in the revolt, seized Pristina, and published a manifesto demanding a dissolution of Parliament and the holding of fresh and fairly conducted elections. Southern Albania joined the insurgents and success followed success. In May Uskub was occupied. In view of trouble brewing elsewhere the Turks had no alternative but to give in. By the terms of the cessation of hostilities, Albania was recognized by the Turkish Government as an autonomous administrative province comprising the four Albanian vilayets of Scutari, Kossovo, Yannina and Monastir, and more or less the same conditions already granted on paper were definitely ratified. Of all these concessions, however, by far the most important was the recognition on the part of Turkey that Albania extended to the four vilayets. This was the first official delimitation of the frontiers of Albania.

The success of the Albanians was, no doubt, a considerable factor contributing to the outbreak of hostilities between Turkey and the Balkan League in the autumn of 1912. The latter were encouraged by the reverses sustained by the Turkish army under their German leaders, and the grant of autonomy, were it allowed time to consolidate the national organization of the country, threatened to jeopardize the aims of the league, which envisaged the partition of Albania. The latter suffered from possessing no effective central authority. Accordingly, when the war broke out in Oct., the Albanians were divided as to the right policy to pursue. The Roman Catholic Maltozes joined the Montenegrins; the Kossovo Albanians fought half-heartedly on the side of the Turks; the rest of the Albanians remained neutral. The Maltozes, moreover, withdrew from the struggle before the end of the hostilities, being enraged at the cruel treatment by the Montenegrins of their Moslem neighbours. In fact, apart from the defence of the two fortresses of Yannina and Scutari, the safety of which was considered a vital point to the life of Albania, the Albanians practically left the Turks alone in their struggles.

During Nov. the greater part of northern and central Albania was invaded by the Serbians and Montenegrins, and the greater part of Epirus was in the possession of the Greeks. Albania seemed lost. But at this juncture the prompt action of Ismail Kemal partially saved the situation. After consulting with the Governments of Austria-Hungary and Italy, the two Powers interested in the maintenance of an integral Albania, he landed in the nick of time at Durazzo before the capture of that town by the Serbians. Thence he proceeded on horseback to Valona and summoned there an assembly of representative notables from all parts of Albania. On Nov. 28 1912 the national flag, the black double-headed eagle of Scanderbeg on a blood-red ground, was hoisted over the town and a formal proclamation of independence was issued together with a declaration of neutrality. This act gave the Austro-Hungarian and Italian Governments the necessary lead for their diplomatic intervention. But owing to the championship of Russia of the allies' cause, the only immediate result of this was the menace of a general European conflict. It was left to England, the only Power with any pretensions to impartiality, to lend her best offices to bring about an accommodation, and it was owing to the untiring efforts of Sir Edward (afterwards Lord) Grey that eventually a peaceful but by no means altogether satisfactory compromise was arrived at. A conference of ambassadors was assembled in London, and on Dec. 20 the principle of Albanian autonomy was admitted. The allies agreed to leave to the Great Powers the task of delimitating the frontiers and defining the status of Albania and a clause was drafted to this effect for insertion in the Treaty of London (May 1913) between the allies and Turkey. On April 7 1913 Sir Edward Grey made the following statement to the House of Commons:—"The agreement between the Powers respecting the frontiers of Albania was reached after a long and laborious diplomatic effort. It was decided that the littoral and Scutari should be Albanian,

while Ipek, Prizren, Dibra and (after much negotiation) Jakova should be excluded from Albania. This arrangement leaves a large tract of territory to be divided between Serbia and Montenegro as the fruits of victory."

"It is to be borne in mind that in making that agreement"—Sir Edward Grey added in answer to a question—"the primary essential was to preserve agreement between the Powers themselves." The natural rights of Albania were accordingly sacrificed for the sake of the general peace of Europe.

In pursuance of this decision two international commissions proceeded to Albania, the one to delimitate the northern and north-eastern, the other the southern frontiers. The duties of the first were largely of a technical character, since with the exception of two or three small gaps the ambassadors had themselves traced the frontiers with some precision. The northern commission was, however, never called upon to report. Thus half a million Albanians forming a compact ethnographical unit within the watershed which constitutes the natural geographical boundary of Albania were left without appeal to Montenegro and Serbia. The southern commission was given wider powers. Under the chairmanship of Lt.-Col. Doughty Wylie the work was undertaken conscientiously, and resulted in the drawing of a frontier which may be considered in the circumstances a fair balance of conflicting ethnographical, geographical and economic claims.

*Rule of William of Wied.*—Meantime the status of Albania was defined by the ambassadors. On July 29 1913 it was agreed to recognize her as a sovereign independent state under perpetual neutrality guaranteed by the Powers. A foreign prince was to be chosen as ruler. Dutch officers were commissioned for the organization of an Albanian gendarmerie and an international commission of control was instituted, composed of one delegate from each Power and one Albanian representative, with authority for ten years to control the finances of the new State and to check the Albanian Government when acting beyond the limits of its jurisdiction.

On account of the mutual jealousies of the Powers, and especially of those of Italy and Austria-Hungary, it had become impossible to choose for prince any man of known purpose or courage. Prince Charles of Rumania and the Duc de Montpensier were among the abler candidates turned down. Ahmet Fuad Pasha of Egypt was suggested but Ismael Kemal let it be clearly understood that Albania intended to become a European State, and would not accept an Eastern ruler. The choice eventually fell upon Prince William of Wied.

When the international commission of control assumed the sovereignty of Albania at the request of Ismael Kemal in Jan. 1914 pending the arrival of the prince, the number of governments ruling over the several provinces were three. First in priority was the Provisional Government of Ismael Kemal at Valona. The second was the international administration of Scutari, with Gen. Phillips in command. The third was the Government of Essad Pasha in central Albania. This adventurer, after bringing about the murder, so it seems, of the Turkish commander defending Scutari, had betrayed the city in April 1913 into the hands of the Montenegrins on condition of being allowed to march out at the head of his armed followers. These he kept in hand, and on the withdrawal of the Serbs from central Albania he profited by the general discontent with the slow-moving over-cautious Government of Valona to establish a new government under his personal direction at Tirana. Meantime the Montenegrins had been persuaded by the Powers to evacuate Scutari and only the Greeks in the south remained in occupation of Albanian territory within the new frontiers.

Essad reluctantly consented to hand over the reins to the international commission of control on the condition that he himself might head the deputation to Newburg for the purpose of offering the crown to Prince William. He continued, however, to intrigue against his chief, who bestowed upon him after his arrival at Durazzo (on March 7 1914) the post of Minister of War. The general situation was at this time exceedingly confused. The country was rife with disaffection due to the endless

delays before the choice and arrival of the Prince, to the intricate cross-currents of intrigue of Essad, Austria and Italy, and to the ghastly terror that the Greek irregulars—secretly supported but officially repudiated by the Greek Government—constituted in the south. Only a bold man capable of striking the imagination of his people could hope to succeed in these circumstances. Prince William, who even before his arrival had alienated the sympathy of many for having laid himself open to suspicion as implicated in the Austrian plots, revealed himself before long a man of neither courage nor resolution. He remained at Durazzo under the guns of Italian and Austrian warships, chiefly occupying himself in making and unmaking his Cabinet.

In the meantime Essad, who had the goodwill of the Italians, continued to intrigue with the object of discrediting the Prince, while the Austrians and the Nationalist Albanian supporters of Wied plotted with equal pertinacity for the overthrow of the powerful Minister of War. The mistakes of the Prince were at first entirely ascribed by the populace to Essad's machinations. As a result, during the night of May 19, a group of armed Nationalists surrounded his house and Prince William's Austrian guns were trained upon it. Essad's life was only saved by the courageous intervention of an Italian officer. He was eventually placed upon an Italian warship and transported to Italy. Immediately after his departure rebellion broke out among his partisans at Tirana. It might easily have been crushed, for Essad's followers, though well armed, were limited to a few thousand men and were detested by the vast majority of the people. But Prince William at first hesitated, then blundered by bombarding the perfectly inoffensive village of Shayak (Shyak), which raised the whole immediate countryside in revolt, and finally lost all caste in the eyes of the Albanians by ignominiously taking refuge during an abortive attack by the insurgents on board a man-of-war. He was never again likely to win the goodwill of his people. When the World War broke out in Aug. 1914, he was still closely besieged in Durazzo. On Sept. 3 he abandoned the country.

*The World War.*—The history after the outbreak of the World War may be very briefly told. Essad returned to Durazzo, and with the help of his friends the Serbs was able for a short time to reestablish his rule in central Albania. The international occupation of Scutari was followed by a Serbian occupation. The Greeks took possession of the south until the advent of the Italians in 1915. The rest of the country fell under the authority of local chiefs. Essad remained faithful to his plan which foreshadowed the partition of his country between the Serbs, the Greeks, and himself, under Italian protection. In the absence of any authoritative Albanian Government he succeeded for a time in imposing upon the Entente Powers the notion that he represented the will of his countrymen. It was owing to this fact that the articles relating to Albania in the Pact of London were admitted and it is these articles which have given rise to grave difficulties attendant on the settlement of the country since the Armistice of 1918. The articles in question run as follows:—

#### Article 6.

Italy shall receive full sovereignty over Valona, the island of Saseno and surrounding territory of sufficient extent to assure defence of these points (from the Voyusa to the N. and E., approximately to the N. boundary of the district of Chimara on the S).

#### Article 7.

Should Italy obtain the Trentino and Istria in accordance with the provisions of Article 4, together with Dalmatia and the Adriatic Is. within the limits specified in Article 5, and the Bay of Valona (Article 6), and if the central portion of Albania is reserved for the establishment of a small autonomous neutralised State, Italy shall not oppose the division of N. and S. Albania between Montenegro, Serbia and Greece, should France, Great Britain and Russia so desire. The coast from the S. boundary of the Italian territory of Valona (see Article 6) up to Cape Stylos shall be neutralised.

Italy shall be charged with the representation of the State of Albania in its relations with foreign powers.

Italy agrees moreover to leave sufficient territory in any event to the E. of Albania to ensure the existence of a frontier line between Greece and Serbia to the W. of Lake Ochrida.

In Nov. 1916 the Italians had occupied Valona. In the autumn of 1915 the Austro-Hungarians, after overrunning Serbia, occupied northern and central Albania. Essad retired to Salonika where he continued to pose for some considerable time as the true Albanian representative until he became finally discredited. Many Albanians adhered to the cause of the central empires. This was not unnatural since a victory for Germany would in all probability have given Albania an autonomous, if not an independent, government within wider frontiers than she could ever otherwise hope for. Under Bairam Tsurri, an unsurpassed *guerillero*, Albanian bands harassed the Allied lines of communication which ran from Santi Quaranta to Koritsa and Salonika.

On June 3 1917 Italy proclaimed the independence of all Albania under Italian protection. This proclamation was subsequently explained as not denoting a "protectorate," but it could hardly be interpreted as anything but a formal repudiation of the articles of the Pact of London. The French, who had occupied the Ersek-Koritsa road, replied by proclaiming the republic of Koritsa. After three months the republic was abolished, but the district remained under French rule until May 1918, when it was handed over to the Albanians. Then came the retreat of the Austrians in the autumn of that year. Thus the greater part of Albania fell under the occupation of Italy. An inter-Allied contingent on the other hand occupied Scutari, while Serbian troops seized Mt. Tarabosh and advanced their line considerably west of the 1913 frontier.

In March 1920 the inter-Allied command at Scutari handed over their powers to a small Italian contingent, which in May 1921 still remained in the town as representing the Allied and Associated Powers pending the formal recognition of the Albanian State and the confirmation of its frontiers.

Meantime important events had occurred which finally paved the way for the reestablishment of Albanian independence. The Italians permitted the formation of a new national provisional government within their area of occupation, and Albania's case was duly presented at the Peace Conference in 1919. Her representatives included Turchan Pasha, who had acted as Prince William's prime minister; Dr. Tourtuli of Koritsa, the eminent specialist in tropical diseases; Mgr. Bumci, Bishop of Alessio; and Mehmet Bey Konitz, later Minister of Foreign Affairs and representative of the Vatra, an important national society of Albanians resident in America which had risen during the last ten years under the able organization of Faik Konitz and Mgr. Fa Noli, to take a leading part in the cause of Albanian independence. The general complications of the Adriatic question, however, prevented the Albanian case being concluded. President Wilson vetoed a proposal to partition the country. The Italians at the same time lost their initial popularity. It was generally understood that they had provisionally accepted a mandate for Albania. There were evident signs in any case of an intention on their part to remain in permanent occupation. They treated the local authorities with scant courtesy and seriously hampered the independent working of the central Government. The latter were also keenly aware that a permanent Italian occupation inevitably entailed the admission of at least part of the Greek and Serbian claims to their territory.

It was in these circumstances that fighting broke out between Albanian irregulars and the Italian troops, which had been greatly reduced in numbers and were suffering badly from malaria. The Italians accordingly concentrated within certain strategical areas, and thus enabled a new and more representative Albanian Government to be formed in Feb. 1920, first at Lyusna and then at Tirana, under the presidency of Suleiman Bey Delvina. Four constitutional regents were simultaneously appointed, namely, Mgr. Bumci, Dr. Tourtuli, Abdi Toptani and Akif Pasha—i.e. two Mussulmans, one Catholic and one Orthodox. Later in the year the Albanians under Bairam Tsurri again attacked the Italians, capturing many important positions and pressing them hard within the Valona area itself. Italy was in no mood for further wars. The economic and social condition of the country forbade any hope the Italian Nationalist

parties still entertained of imposing by force of arms Italian rule in Albania. Moreover, Giolitti had assumed power with a large Liberal majority behind him, and he had made up his mind to tackle the Albanian question otherwise. The result was an agreement signed on Aug. 2 1920, by which Albania's independence was completely recognized by Italy and the evacuation of the country by the Italian troops assured.

The Serbs, who had attempted to profit by the occasion, had advanced on Tirana, but after some severe fighting had been driven back to their original positions. Yet in spite of these successes the Government of Suleiman Bey fell in the autumn. It was replaced by a Ministry under Ilias Vrioni, pending the election due to take place in the following spring of a new Chamber, Mgr. Fa Noli was appointed Albanian representative at Geneva and in Jan. 1921 Albania was formally admitted to full membership of the League of Nations, all the parties (Italy, Serbia and Greece), at one time interested in her dismemberment, recording their vote in favour of the motion.

**BIBLIOGRAPHY.**—Foreign Office Manual No. 17; Constantine A. Chekressi, *Memoirs*; Ismael Kemal, "Albania and the Albanians," *Quarterly Review* (July 1917); J. S. Barnes, "The Future of the Albanian State," *Jour. Roy. Geo. Soc.* (July 1918); A. Baldacci, *Itinerari Albanesi 1892-1902* (1917); E. Barbarich, *Albania* (1905); E. Durham, *The Burden of the Balkans* (1905; 2nd ed. 1912); *High Albania* (1909); *The Struggle for Scutari* (1914); K. Hassert, *Streifzüge in Ober-Albanien*; Leon Lamouche, *La Naissance de l'Etat Albanais*; Louis Jaray, *L'Albanie inconnue* (1913); *Au jeune royaume d'Albanie* (1914); W. Peacock, *Albania* (1914); Sullioti, *Sei Mesi di regno in Albania* (1914); Haskins and Lord, *Some Problems of the Peace Conference* (1920); *Report of Dutch Mission in Albania* (1914); *Report of French Ministry of War* (1915); *Report of Italian Ministry of War* (1915); *Report of Italian Ministry of Marine* (1917); Karl Steinmetz, *Von der Adria zum Schwarzen Drin* (1908); *Eine Reise durch die Hochalpine Oberalbanien* (1904); *Ein Vorstoss in die nordalbanischen Alpen* (1905); Baron Nopcsa, *Das Katholische Nordalbanien* (1907); *Aus Sala und Klemente*; Marchese di San Giuliano, *Lettere dall'Albania*; Miller, *The Ottoman Empire 1801-1913*, Cambridge Historical Series (1913). (J. S. BA.)

**ALBERT I.**, King of the Belgians (1875- ), was born at Brussels April 8 1875, the younger son of Philip, Count of Flanders (1837-1905), brother of Leopold II., by his marriage with Princess Marie of Hohenzollern. The other children of this marriage were: Baldwin (b. 1869), Henriette, afterwards Duchess of Vendôme (b. 1870), a daughter who died in infancy, and Josephine, afterwards Princess Charles of Hohenzollern (b. 1872). The premature death of Prince Leopold, only son of Leopold II., on June 22 1869, made Prince Baldwin heir presumptive to the Belgian crown, but on the death of the young prince on Jan. 23 1891, Prince Albert became next in the line of succession. He was carefully educated, and showed a marked taste for engineering and mechanics, studying both naval and aerial construction. He received his training in military matters at the *École Militaire* under Gen. Jungblut, and also became a thorough all-round sportsman, taking much interest in mountaineering and later in aviation. On Oct. 2 1900 he was married at Munich to Princess Elisabeth (b. July 25 1876, at Posenhofen), second daughter of Duke Charles Theodore of Bavaria. Three children were born of this marriage: Leopold, Duke of Brabant (b. Nov. 3 1901), Charles, Count of Flanders (b. Oct. 10 1903), and Marie José (b. Aug. 4 1906).

Prince Albert also travelled widely, paying a visit to America in 1898, and in 1908 visiting England in order to study naval construction. In April 1909 he went to the Belgian Congo in order to acquaint himself with colonial conditions, returning in Aug. of the same year.

On the death of Leopold II. on Dec. 1 1909 Prince Albert took the oath of fidelity to the Belgian constitution and became king under the name of Albert I. He occupied himself more especially with the organization of the army and in May 1913 gave his assent to the law which was designed to secure for Belgium an army of 350,000 men. He also interested himself in various social and legal reforms, while his scientific tastes did not prevent him from becoming a friend of art and



literature. The poet Verhaeren and the painter Laermans were on friendly terms with the royal family, the latter receiving personal attention from the Queen when he was threatened with the loss of his sight.

On Aug. 2 1914, when the Germans sent their ultimatum to Belgium, King Albert at once prepared to defend his country. He himself took command of the army. He only left Antwerp at the last possible moment, and then established himself with the army on the Yser. During the whole of the war he remained with the troops, having his headquarters at La Panne, where he was exposed to the risk of enemy bombardments. He made continual visits to the front-line trenches, and even surveyed the enemy's lines from an aeroplane. The Queen remained with him, acting as a nurse in the Hôpital de l'Océan at La Panne. She also interested herself deeply in the welfare of the soldiers in the trenches, and superintended the establishment of canteens and aid posts. Prince Leopold, King Albert's elder son, lived by his father's wish the life of a simple soldier in the 12th Regiment.

When the general offensive of Oct. 1918 was undertaken, King Albert was appointed commander of the northern army groups, consisting of both Belgians and French, which captured the forest of Houthulst, the Flandernstellung, Thourout, Ostend and Bruges, and forced the passage of the Lys. On Nov. 13 1918 the King and Queen made their entry into Ghent, and on Nov. 23 into Brussels, being received with enormous enthusiasm. Even before the signing of the Armistice the King had summoned at Lophem a number of politicians, and arranged a new Government containing representatives of the three most important Belgian political parties.

After the Armistice the King occupied himself actively with the improvement of conditions in his country, visiting the devastated areas, and contributing considerable sums to "King Albert's Fund," which was devoted to providing temporary shelter for sufferers from the war. He also undertook journeys to Brazil, Spain, France, the United States and England, with the object of studying trade conditions and finding new outlets for Belgian commerce. The popularity of the King and Queen, great even before the war, steadily increased, even the Socialist party taking many opportunities of expressing feelings of respect towards the royal family. King Albert declined the augmentation of his civil list which was offered to him by the Chamber immediately after the war.

See P. Nothomb, *Le Roi Albert*; Laureat, *Le Roi Albert*; Baron Buyens, *Les hommes de la Guerre—Le Roi Albert*; G. Mathys, *Le Prince Albert*; Mousseau, *Le Prince Albert au Congo*; *La Mort de Léopold II. et l'Avènement du Roi Albert* (Recueil de Documents, 1909); Roux, *Le Roi Albert*; Percy, *The Life Story of Albert I., King of the Belgians* (1914); MacDonnell (John de Courcy), *The Life of H.M. King Albert* (1915) and *Belgium: her Kings, Kingdom and People* (1914). (J. P.)

**ALBERT, DUKE OF WÜRTTEMBERG** (1865— ), German general, the son of Duke Philip of Württemberg, was born in Vienna on Dec. 23 1865. As the King and Queen of Württemberg had no male heir, he was as nearest agnate the heir presumptive to the Württemberg throne. He passed through the different grades of a military career and was appointed general in command of the XI. Army Corps at Cassel in 1906 and in 1908 was entrusted with the command of the Württemberg Army Corps. In 1913 he was advanced to the rank of Generaloberst (colonel-general, immediately below field-marshal) and was appointed Inspector-General of the 6th Army Inspection. At the outbreak of the World War he took over the leadership of the 4th Army on the western front, was advanced to the rank of field-marshal-general in 1916 and appointed chief-in-command of the group of armies on the front in Alsace-Lorraine, which fought under his leadership till the end of the war. Since then he has lived as a private citizen on his Württemberg estates. He married in 1902 the late Archduchess Margarete Sophie of Austria, the sister of the Archduke Francis Ferdinand who was assassinated at Sarajevo.

**ALBERTA** (see 1.499).—The pop. of the Canadian province of Alberta in 1916 was 496,525. The increase since 1901 is shown in the following table:—

Year.	Male.	Female.	Total.
1901	41,019	32,003	73,022
1906	108,283	77,139	185,412
1911	223,989	150,674	374,663
1916	277,256	219,269	496,525

The urban pop. amounted in 1916 to 188,749 and the rural to 307,776. There were 119,510 families inhabiting 113,347 dwellings, the average number in the family being 4.15. The origins of the people were as follows:—Canadian-born 241,357, English 70,068; Irish 36,420; Scotch 47,494; Welsh, etc., 1,500; French 17,679; German 12,486; Austro-Hungarian 11,868; Scandinavian 9,825; Dutch 2,465; Indian 14,118, Polish 1,791; Russian 6,422; Ukrainian 4,024; others 5,197. Of U.S. immigrants of all nationalities born in the United States there were 91,674, almost precisely 50% of them being of British descent.

**Edmonton** is the capital, with a pop. estimated in 1920 at 60,000 (24,900 in 1911). It is beautifully situated on the N. bank of the North Saskatchewan on a table-land overlooking and 200 ft. above the river. It is the depot of the fur traders of the northern forest and the western headquarters of the Hudson's Bay Company. Edmonton is the terminus of the Calgary and Edmonton railway, and a divisional point of the Canadian National railways. It owns and operates its own electric light and power plant, waterworks, sewerage, telephones and street railway system. It has flour mills, saw mills and meat-packing plants.

**Strathcona**, on the S. bank of the North Saskatchewan river, is the seat of the university of Alberta, and a popular residential district. Fort Saskatchewan, Vegreville, and Vermilion are thriving trading towns on the Canadian National railway.

**Calgary**, the chief city of the southern district, and the principal business section of the province, is situated in the valley of the Bow river. It had in 1920 a pop. estimated at 75,000 while in 1911 the pop. was 43,794. It is on the main line of the C.P.R. and the lines of the Canadian National railway. The manufacturing establishments include meat-packing plants, flour mills, lumber mills, brick and cement works. It is the door to the magnificent scenery of the Rockies, and the great number of summer tourists has necessitated the building of large modern hotels.

**Medicine Hat** had in 1920 an estimated pop. of 10,000, and is the centre of a wide area of ranching and farming country. It is one of the large flour-milling centres and is known as the natural gas city, having been supplied with natural gas from the time of its inception. Bricks and drain pipes are extensively manufactured.

The pop. of **Lethbridge** was estimated at 10,000. It is a thriving coal-mining, agricultural and railway centre, and is an important neighbourhood for irrigation farming, the Dominion experimental farm being situated there.

Other local centres are Red Deer, Wetaskiwin, Bairore, Camrose, Cardston, Coleman, Lacombe, Macleod, Pincher Creek, Raymond, Redcliff, Stettler, High River, Taber and Vegreville.

The Legislative Assembly of Alberta consists of 58 members, with an Executive Council composed of eight members chosen from the Legislature. The province is represented in the Dominion Parliament by 12 members in the House of Commons and six Senators.

High schools have been opened at all the leading centres, and normal schools for the training of teachers are in operation at Calgary and Camrose. The province owns 250 ac. of land at Edmonton, where a well-equipped university has been established. Alberta College, a Methodist theological training school, a Presbyterian theological training college, and other denominational institutions are affiliated with the university. Technical schools are established at Edmonton, Calgary, and Medicine Hat. Schools of agriculture are established at different points and there are nine demonstration farms; the university has a faculty of agriculture.

**Agriculture.**—Until the end of the 19th century southern Alberta was regarded as only fit for ranching, but in 1902 the first irrigation company was formed and received its charter. Since then numerous irrigation projects have been undertaken, and a large area of land is now farmed with the help of the water thus made available. The area of the land owned by the irrigation companies of southern Alberta made up in 1920 a total of nearly 3,000,000 ac. of which 30% is actually irrigable land. The benefits of irrigation have been well demonstrated in southern Alberta. Besides making it possible to grow heavier and better crops it is possible to grow a greater variety. On dry land grain is the characteristic crop. Under irrigation heavy crops of alfalfa and roots are grown, which make profitable stock-raising and stock-feeding possible without the uncertainties and loss which accompany seasons of drought. More stock is raised in southern Alberta now than was raised under ranch conditions. The chief



credit for developing the irrigation system belongs to the C.P.R. company, whose scheme covers about 1,000,000 ac. in the area around Calgary, where a heavy thick black loam of from 4 to 8 in. in depth, with a subsoil of chocolate-coloured clay, constitutes a region well adapted to diversified farming. The source of water supply is the Bow river. The soils of northern Alberta are for the most part characterized by high percentages of organic matter and nitrogen, and are superior to those in the southern part of the province. Southern Alberta is of a true prairie character. Northern Alberta is to a large extent wooded, enjoying a greater rainfall, and is naturally better adapted for mixed farming. Alberta is adapted in varying degrees to the growing of small grains, including wheat, oat, barley, rye, peas and flax, which can all be grown successfully and profitably from Medicine Hat to Fort Vermilion. In 1918 the wheat production of the province was 23,751,514 bushels. The oat production in the same year was 60,327,717 bushels. Ninety-six different varieties of native grasses have been identified in Alberta and of these not less than 46 make excellent hay whilst there are at least 94 varieties of sedges and rushes, many of which make good hay and all make splendid pasture during the spring and early summer. The true grasses occur on the uplands, and grow with wild pea, vine and bunch. Native hay, western rye grass, blue grass, buffalo grass and vetch grass abound in luxuriant stretches. These extend through the passes into the mountains and fill the valleys with a luxuriant growth of luscious plants for cattle. Such conditions constitute Alberta as a whole an ideal live-stock country.

There is still however much land devoted to ranching in the foothill country W. of the Calgary-Edmonton railway. This consists of rolling land with good grasses on the knolls, excellent live springs and running water and plenty of natural shelter. Beef is also raised on proprietary ranches of the prairie country, on leased lands in the eastern and central parts, and on the edges of the settled parts of the Peace River country. The superiority of Alberta ranch beef is accounted for by the superiority of the ranch grasses, the climate and the use of good beef stock. The ranch cattlemen have always bought the best bulls obtainable of the Shorthorn, Hereford and Aberdeen-Angus breeds. The demand for pure bred stock is very active, and the establishment of pure bred herd has been going on rapidly.

Building material and fuel in almost unlimited amounts are procurable in the forests of northern Alberta, the timber lands extending hundreds of miles on the N. side of the Saskatchewan river. Poplar, birch, pine, white and black spruce, Douglas fir and larch are among the commercial trees in these forests belts. South of the North Saskatchewan the timber is principally cottonwood and poplar. In the foothills and river valleys considerable spruce is found. Saw-mills have been established at various points. The output for 1918 was valued at \$473,694 and represented a capital investment of \$1,500,000. Over 26,000 sq. m. of territory have been set aside as forest reserves and Dominion parks.

In the mountain section of the province large areas have been set apart by the Dominion Government for forest and game preservation and for recreation. Good roads have been built through these reservations and they are carefully guarded against both fire and illicit hunting. Rocky Mountain park, with Banff and Lake Louise as the chief centres, contains 3,800 sq. m., while Jasper park on the Grand Trunk Pacific is about 600 sq. m. larger. There is also a small reservation at Waterton lake. The Dominion Government under the direction of the Commissioner of Parks has taken steps not only to prevent the total extinction of the buffalo but has established parks for the protection and breeding of these and other native animals. The largest of these parks, 150 sq. m. in extent, is at Wainwright, where nearly 3,800 of the former monarchs of the plains are living secure from slaughter.

**Fishing and Fur Trading.**—The immense lakes of northern Alberta are heavily stocked with fish, the most important being whitefish and pike. Trout and pickerel are also abundant. The catch is used largely for local consumption but there is some export, and prospects of future large developments. Fur trading is still an important industry in the northern section of the province of which Edmonton is the centre. Otter, mink, ermine, wolverine, marten, badger, squirrel, bear, fox, wolf and lynx all enter into the production. Three companies, in addition to many private traders, are engaged in the traffic.

**Coal.**—Vast beds of coal are found extending for hundreds of miles a short distance below the surface of the plains. It may almost be said that the whole of the province is underlain with coal, and it is estimated that 16% of the coal deposits of the world occur in Alberta. Anthracite is only found in one small pocket near Banff, which was opened some years ago but has not been operated for some time. Every other grade of coal ranging from the best bituminous to ordinary brown coal or lignite is found. Broadly, the better grades are found next to the Rockies where the carboniferous strata have been subject to the greatest pressure, the quality falling off as we proceed eastward. Owing to the general movement at the time of the formation of the mountains the strata of coal have been very much broken up. On this account coal-mining in Alberta, although the seams lie very close to the surface, is of a very difficult nature. The mines must be closely timbered right up to the working face. Over 5,000,000 tons are mined annually, to a value of over \$10,000,000, the mines being equipped for an output of 15,000,000 tons.

Natural gas under heavy pressure is found at many points throughout the province and is extensively used for power, fuel and light. In the Athabasca region and near the B.C. boundary there are decided indications of petroleum and a limited amount of coal oil is now being refined. The tar sands of northern Alberta are a striking feature in the geological resources of the province. It is estimated that the area of tar sands amounts to at least 1,000 sq. m. which with an average thickness of 150 ft. would give 28.4 cub. m. or 4,700,000,000 tons of bitumen or 6.5 cub. m. of tar. The sands of the North Saskatchewan river have for years yielded some gold. The output of clay and stone in the province is valued at over \$1,000,000 annually. There are also large salt deposits in the northern part of Alberta. The annual mineral production of the province exceeds \$15,000,000.

**Manufactures.**—There are large and prosperous manufacturing establishments which supply local needs and engage in export business. Large abattoirs and meat-packing plants are located at Calgary and Edmonton. Throughout the province there are flour and saw-mills, brick-yards and tile works, cement works, stone quarries and other manufacturing enterprises.

**Communications.**—In former days the North Saskatchewan was chiefly depended on for carrying freight by steamboats, but transport has been largely transferred to the railways which extend throughout the province in every direction. The main line of the C.P.R. sends a branch N. to Edmonton and another S. to Macleod. From the Edmonton branch there are two offshoots starting at Lacombe and Wetaskiwin. Other branches diverge from the main line at different points, extending into the new districts. The great passes of the Yellowhead and Peace river have also been made high-ways of traffic. The Canadian National railway lines connect Edmonton with Winnipeg and Port Arthur on the E. and with Vancouver and Prince Rupert on the W., the latter going through the Yellowhead pass. The same system has also a line to Calgary from the E. as well as extensions westward into the coal fields. Two other railways, built principally for colonization purposes, open up vast stretches of new country and are proving of inestimable value in connexion with the Peace river district and the northern country. These are the Edmonton and Great Waterways, and the Edmonton, Dunvegan and B.C. railway; the latter has been taken over by the C.P.R. from the Government of Alberta. Stern-wheel steamers ply on the rivers and lakes of the northern section during the summer months.

Alberta was the first province of the Dominion to own and operate a telephone system of its own. In the year 1911 the province owned and operated 3,500 m. of long-distance lines and about 2,500 m. of rural or farmers' lines, and this service has been annually extended. (W. L. G.)

**ALCOCK, SIR JOHN** (1809-1910), British airman, was born in Manchester Nov. 6 1809. He received his technical training there at the Empress motor works and obtained the flying certificate of the R.A.C. in 1912. He joined the R.N.A.S. at the beginning of the World War, being appointed instructor at Eastchurch and, later, chief instructor to the aeronautic squadron. He then went to the Turkish front, winning the D.S.O. for an attack on three enemy seaplanes, and also establishing a record for long-distance bombing flights. He was taken prisoner by the Turks in 1917 and released after the Armistice. On June 13 1919 Alcock, as pilot, with Lt. A. W. Brown as observer, won the prize offered by the London *Daily Mail* for the first successful flight across the Atlantic. For this achievement both airmen were knighted. On Dec. 18 1919 Alcock was killed by the crashing of his aeroplane at Côte d'Évrard, north of Rouen, in France.

**ALCOHOL** (see 1.525).—Alcohol intended for potable purposes has always been subject to a heavy duty in all countries. In the United Kingdom the duty on alcohol was raised in 1920 from 50s. to 72s. 6d. a proof gallon. Owing to its prohibitive price, duty-paid alcohol cannot be used for the many purposes for which it is essential, quite apart from the production of light, heat and power. Its earliest employment in industry was as an illuminant, and dates back to the early part of the 19th century.

In 1853 exhaustive experiments were carried out in England with a view to ascertaining whether it would be possible so to treat alcohol as to allow it to be used industrially without, at the same time, any risk of the revenue being defrauded. These experiments resulted in the legislation of 1855, when the use of duty-free alcohol mixed with 10% by volume of wood naphtha, known as methylated spirits, was authorized for manufacturing purposes only. From 1861-91 methylated spirits prepared in this way were allowed to be sold by retail in Great Britain in small quantities for domestic purposes such as cleaning, heating

and lighting; but use in large quantities, or in manufacture, was only possible under special authority and under excise supervision. The Netherlands legalized the use of denatured alcohol in 1865; in 1872 France permitted its use under a special tax, and in Germany its employment was authorized in 1879, the other European countries following, Austria in 1888, Italy in 1889, Sweden in 1890, Norway in 1891, Switzerland in 1893, and Belgium in 1896. In the United States the tax on distilled spirits was repealed in 1817, but was reimposed at the outbreak of the Civil War in 1861, and it was not until 1907 that denatured alcohol became tax-free for general purposes. Alcohol was used in Germany for many years before the World War in increasing quantities as a source of heat, but its application for light and power started about 1887. In 1895, in order to bring down its price, a distillation tax was imposed, from which a refund was paid on alcohol used for other than beverage purposes. About this date the output of alcohol in Germany and its use in stationary internal-combustion engines increased rapidly. The chief source was the bounty-fed potato, and the industry was an agricultural one worked on coöperative principles.

The first competition in connexion with alcohol as a fuel for motor vehicles took place in France in 1901, followed in the next year by German investigations, but its employment for this purpose did not make much headway. The subject received little attention in the United Kingdom, owing to the relatively high cost of home-produced alcohol as compared with that of imported petrol; and the use of alcohol in England for generating mechanical power was neither contemplated nor provided for by the Legislature before 1920, when, as the result of the consideration of the position by the Government, following on a report by a Departmental Committee appointed towards the end of 1918, clauses were inserted in the Finance Act of 1920 legalizing the use of alcohol for power purposes.

Whilst alcohol is applied in motor engines in a similar manner to petrol, its vapour mixed with a proper proportion of air being drawn into the cylinder where it is compressed and ignited, it cannot be used with maximum efficiency by itself in engines such as are fitted to modern motors because it requires a higher degree of compression than petrol engines are usually designed to stand, and also because, unless special arrangements are made, a motor engine will not start readily from the cold with alcohol alone. For these reasons alcohol has not been used to any extent in petrol motors. Mixing with benzol and/or petrol, or with ether in varying proportions, enables it, however, to be employed successfully in them, until such time as engines specially designed for its use are available. In the event of its production being a commercial possibility it should, therefore, form a valuable addition to the liquid-fuel resources of the world (see FUEL).

In the appended table are given some comparative figures in connexion with commercial petrols and alcohol, taken from H. R. Ricardo's paper on "The Influence of Various Fuels on the Performance of Internal-Combustion Engines," published in 1921.

Alcohol and Petrol as Fuel.

	Sp. gr. at 15°C.	Latent Heat at (const. Press.) B. Th. U. per lb.	Corrected Cal- orific Value B. Th. U. per lb.	Minimum Com- pression, lb. per sq. in. H. P. hour.	Corrected ther- mal efficiency per cent.	Minimum Com- bustion at const. P. per sq. in. H. P. hour.
Petrols { from	0.704	132	18,580	0.414	31.6	0.389
to	0.782	142	19,250	0.425	31.9	0.355
Alcohol						
95 Vol. %	0.815	442	11,130	0.705	32.5	0.565

Alcohol is produced by fermentation from vegetable substances containing starch or sugar, from fermentable sugars produced by the hydrolysis of cellulosic bodies, and synthetically from calcium carbide and from the ethylene contained in coal and coke-oven gases. These vegetable substances may be divided into foodstuffs and non-foodstuffs. If foodstuffs are to be employed it must be possible to grow them in excess of food requirements, and at a cost low enough to ensure that the price of the alcohol shall be about the same as that

<sup>1</sup> The lower calorific value plus the latent heat of evaporation at constant volume.

of other liquid fuels. Foodstuffs could not be grown in the United Kingdom at sufficiently low prices, nor in sufficient quantities, to produce alcohol commercially and on a large scale.

Investigations started in 1920 by the British Government, in connexion with the production of alcohol for power purposes, have shown, however, that there are large areas of suitable land in the British Empire where the cost of production would be comparatively low, and where it might be possible to grow vegetable substances in excess of food requirements, and in sufficient quantities to produce alcohol for local consumption to replace expensive petrol. It is in this direction, which is being actively followed up in the dominions and colonies, that the production of alcohol for use in internal-combustion engines is most likely to advance so far as the British Empire is concerned.

The use of non-foodstuffs, or cellulosic materials, such as grasses, reeds, straws, peat, waste wood, sawdust, etc., is not yet possible, for, although research work is in progress to discover a process that could be worked on a commercial basis in those regions where such materials exist in sufficient abundance, it has not so far led to any definite results. It would appear, however, that the production of power alcohol within the British Empire from waste materials, which can be collected and treated at low cost, offers the best chance of the solution of the problem of the supply to the United Kingdom of an alternative liquid fuel for internal-combustion engines.

Its manufacture from carbide is only possible where very cheap power is available, and its conversion from the quantities of ethylene removable from coal and coke-oven gas, even should a cheap process be worked out, is not likely to add very materially to the world's liquid-fuel supplies.

Whilst the use of alcohol for power purposes, mainly in connexion with stationary and agricultural engines, was common in Germany before the war, its employment in Europe and also in the United States for motor engines has not made much headway, nor was it apparent in 1921 that any active steps were being taken outside the British Empire to develop it for the purpose on any considerable scale. In France, where large stocks of alcohol were left over from the manufacture of explosives during the war, it was unable to compete with petrol as regards price, and was only being used in comparatively small quantities, and mixed with benzol. The German production of alcohol had fallen off very much since the war, and little if any was being used for motors, benzol being the fuel principally employed. The manufacture of alcohol from the sulphite lyes of the wood-pulp industry was contemplated, but carbide, although produced in increasing quantities, was not considered as a possible raw material owing to its greater importance as a source of the fertilizer cyanamide. An alcohol monopoly law was passed in July 1918. With cheap water-power Switzerland has considerable capacity for producing carbide and alcohol from it, but even in that country the ultimate cost of alcohol made in this way was so high that its production after the war had not paid. In Sweden, where wood pulp is made in enormous quantities, the manufacture of alcohol from the waste sulphite lyes is carried on, and it was estimated that in 1920 the probable capacity was in the neighbourhood of 8,000,000 gal.; the actual production, however, amounted to about 2,750,000 gal. only. Norway also produces sulphite lyes and alcohol from them on a smaller scale.

There are several distilleries in the United States devoted to the production of industrial alcohol, with an estimated capacity of about 90,000,000 gal.; in 1919 about 100,000,000 gal. were made, representing, however, only about 2½% of the estimated United States liquid-fuel requirements for 1920. Some attention is also being given to the manufacture of alcohol for power purposes in Hawaii, Porto Rico and the Philippines; and in Cuba, from the molasses produced as a by-product in the sugar refineries. (F. L. N.)

**ALDEN HENRY MILLS** (1836-1910), American editor, descendant of John Alden, was born at Mt. Tabor, Vt., Nov. 11 1836. After graduating from Williams College (1857), under the régime of Mark Hopkins, he completed the course at the Andover Theological Seminary (1860); but he never took orders. He first contributed to the *Atlantic Monthly* two essays on "The Elucisnia" (1859-60), and then a paper on "Pericles and President Lincoln" (1863). These fruits of his classical studies show the influence of De Quincy, who was the subject of another essay in the *Atlantic* (1863). He delivered twelve lectures before the Lowell Institute in Boston, 1863-4, on "The Structure of Paganism." He was managing editor of *Harper's Weekly* from 1863 to 1869, and then became editor of *Harper's Magazine*, which position he held until his death in New York, Oct. 6 1919.

He was author of *God in His World* (1890); *A Study of Death* (1895) and *Magazine Writing and the New Literature* (1908).

**ALDRICH, NELSON WILMARTH** (1841-1915), American politician (see r. 536), died in New York April 16 1915. While chairman of the National Monetary Commission, he pro-

posed, in 1911, far-reaching changes in the banking laws of the United States with a view to the creation of central reserves, a system afterwards adopted in the Federal Reserve banks. He retired from the U.S. Senate in 1911, after 30 years' service.

**ALEXANDER**, King of the Hellenes (1893-1920), second son of King Constantine and Queen Sophia, was born Aug. 1 1893, and ascended the throne of Greece, June 12 1917, on the dethronement of his father by the Anglo-French forces during the World War (see CONSTANTINE). He, not unnaturally, looked upon his position at first as a mere temporary arrangement. The Government itself was meanwhile in the responsible hands of Venizelos, who had the confidence of the Allies. But the defeat of Germany, and Venizelos's diplomatic triumphs at the Peace Conference, seemed to breathe a new spirit into the young King. From the day of his triumphal entry into Adrianople, he evidently took a more active personal interest in the prospect of being the ruler of Greater Greece. This change in his attitude was indeed so marked that his royal parents in exile in Switzerland were said to be greatly disconcerted; but it gave him an entirely new popularity among the people. His sudden death on Oct. 27 1920, by blood-poisoning from the bite of a pet monkey, put a sudden end to all such expectations, and it seriously disarranged Venizelos's plans. King Alexander was buried amid widespread demonstrations of popular grief; but a fortnight later, in the general election, the Venizelist party was defeated. It is practically certain that, could this election have been postponed for a few months and a suitable successor to the throne found, King Constantine would never have been able to return, as he did, to Greece. But postponement was impossible after Venizelos's pledges to the Greek people; and, in the absence of any other serious candidate for the Greek throne, the old sympathies for Constantine won the day.

In Nov. 1919 King Alexander had insisted, against the advice of Venizelos, on making amorganatic marriage with a beautiful young Athenian lady, Aspasia Mano; and after his death a daughter was born to her in Paris on March 25 1921.

**ALEXANDER I.**, King of the Serbs, Croats and Slovenes (1888— ), was born at Cetinje on Dec. 4 1888, the second son of Prince Peter Karadjorgjević (later King of Serbia), and of Zorka, third daughter of Prince Nicholas of Montenegro. His mother died in 1890, and during his early years he of course shared the exile of his father, who lived at Geneva. In 1899 he was sent to be educated at St. Petersburg, and in 1904 entered the *corps des pages* at the Tsar's court. It was not till 1909 (nearly six years after his father's election to the Serbian throne, in succession to the murdered King Alexander Obrenović) that the young prince came to reside permanently in Serbia. Soon after his return his elder brother, Prince George, was obliged to renounce the succession (March 1909), owing to his unbalanced temperament and various incidents that occurred during the Bosnian crisis; and Alexander was thereupon formally recognized as crown prince. On the outbreak of the Balkan War he assumed nominal command of the First Army, and won his spurs at the battle of Kumanovo, subsequently serving with distinction throughout the campaigns against Turkey and Bulgaria. On June 24 1914 King Peter, whose health had completely broken down, appointed him as prince regent, and he thus held the position of commander-in-chief when the World War broke out. He remained permanently at army headquarters, and shared with his soldiers all the privations of the retreat through Albania. On reaching the coast he fell ill and underwent a serious operation, but when already convalescent resolutely declined the proffered assistance of an Italian destroyer which had been sent to convey him across the Adriatic; he remained till all the refugees had been transported into safety, and eventually found his way on foot to Durazzo. After the exiled Serbian Government had established itself at Corfu, Prince Alexander and Mr. Pašić paid visits to Paris and London, where the Prince was received with warm ovations. On April 5 1916, in receiving an important deputation of British sympathizers (led by the Archbishop of Canterbury, the Lord Mayor, Lord Milner and Sir E. Carson), he publicly identified the dynasty with the cause of unity,

expressing his conviction that in the final victory "our Yugo-Slav people, united in a single state, will also have their part." During the rest of the war he remained at Serbian headquarters, and shared his army's victorious advance in Oct. 1918. On Dec. 1 delegates of the Yugo-Slav National Council in Zagreb formally recognized him as regent in all the Yugo-Slav provinces of the former dual monarchy, and he assumed the title of "Prince-Regent of the Serbs, Croats and Slovenes." The attempt made upon his life on June 28 1921, after he had taken oath to the new Yugo-Slav constitution, was the outcome not of any personal unpopularity, but of the subversive aims of the Communists and other revolutionary groups, who hoped to create confusion in the new state, owing to the lack of a direct heir to the throne. On Aug. 16 1921 Prince Alexander succeeded his father as King of Yugoslavia.

**ALEXANDER, BOYD** (1873-1910), British soldier and explorer, was born at Cranbrook, Kent, Jan. 16 1873. He was educated at Radley, and afterwards entered the army, joining the Rifle Brigade in 1893. In 1897 he led a scientific expedition to the Cape Verde Is., and in 1898 went on his first African journey to the Zambezi and Kafuk rivers. He was appointed to the Gold Coast constabulary in 1900, and took part in the relief of Kumasi. In 1904 he led a scientific expedition to Fernando Po, where he ascended Mt. St. Isabel and discovered various new species of birds. The same year saw the commencement of his most important work—the Alexander-Gosling expedition across Africa from the Niger to the Nile, which occupied three years. During this period he surveyed the shores of Lake Chad and explored a considerable part of eastern Nigeria, returning to England by way of the rivers Ubangi, Shari and Nile. For his various discoveries he received gold medals from the Royal Geographical Societies of London and Antwerp, besides honours from other learned societies. He returned to Africa in 1908, and was killed by natives at Nyeri, in Wudal, April 2 1910. Alexander published *From the Niger to the Nile* (1907), besides many articles and papers in scientific and geographical periodicals.

See Herbert Alexander, *Boyd Alexander's Last Journey*, with a memoir (1912).

**ALEXANDER, SIR GEORGE** (1858-1918), English actor (see 1.564), died at Chorleywood, Herts., March 16 1918. He was knighted in 1911. Among his later productions at the St. James's theatre were R. S. Hichens's and J. B. Fagan's *Bella Donna*; Pinero's *The Big Drum* and Louis N. Parker's *The Aristocrat*; in this he made his last appearance together with the veteran actress Geneviève Ward.

**ALEXANDER, JOHN WHITE** (1856-1915), American painter (see 1.564), died in New York June 1 1915. He received a first-class medal from the Carnegie Institute, Pittsburgh, in 1911, and a medal of honour at the Panama-Pacific Exposition in 1915. He had been president of the National Academy of Design since 1909.

**ALEXANDER, WILLIAM** (1824-1911), Protestant Archbishop of Armagh and primate of All Ireland (see 1.565), who resigned his see Jan. 30 1911, and was created G.C.V.O., died at Torquay Sept. 12 1911.

**ALEXEYEV, MIKAIL** (1857-1918), Russian general, was born in 1857, and entered the army in 1876. He completed his studies at the General Staff College in 1890, and joined the Russian General Staff. In 1904 he became a general. He took part in the war with Turkey in 1877-8. During the Russo-Japanese War he was the director of the operations on the staff of the II. Army. After further staff service he became in 1912 commander of the XIII. Army Corps. At the outbreak of the World War he was nominated chief of the staff of the south-western front. The first operations were skillfully carried on by him, and the great Russian victory in Galicia in 1914 was his work. In March 1915 he was called to command the group of armies of the north-western front. A stupendous task awaited him here; eight armies were confided to him, but these masses were destitute of all means of combat. The events in Galicia in April 1915 had their repercussion further north, where the position became desperate, and the army seemed lost. But by the end of Aug. the armies

were saved, thanks to the energy and ability of their commander. In Aug. 1915 he was nominated chief of the headquarters of the supreme command, and worked there with the Emperor, who had just assumed the supreme command. He served in this capacity during the successful campaign of 1916, until in Nov. a breakdown of health compelled him to give up his office. After the revolution of March 1917 he became commander-in-chief, but in May 1917 he was dismissed. Recalled by Kerensky in Sept. he remained at headquarters only 12 days in order to exercise a steadying influence during the conflict between Kornilov and Kerensky, and then left, being unable to work with men who he considered had brought misfortune and shame on his country. At the commencement of the Bolshevik régime he went to the south of Russia, where he soon became the leader of the "Volunteer Army," and took the field against the Bolsheviks. He died of heart disease Oct. 10 1918.

**ALGERIA** (see 1.642).—The figures of the 1911 census showed a total pop. for Algeria of 5,492,560, of whom 752,043 were Europeans. Of these 558,572 were French, 134,746 Spaniards, concentrated specially in the department of Oran, and 36,661 Italians, in the region of Constantine.

The administration of the country was still in 1921 in the hands of a governor-general residing at Algiers, as supreme head of all the civil services, with the exception of the non-Muslim services of justice, worship, public instruction, treasury and customs, which remained attached to the French ministerial department. The governor-general has to assist him a general secretary and a Government council. Since 1900 Algeria has enjoyed a large measure of budgetary autonomy. The governor-general submits a special budget to the vote of Algerian representative assemblies, or the financial delegations which were created in 1808. The delegations are divided into three sections, one of which represents colonists, another non-colonising taxpayers, and the third native Mussulmans. The budget, when voted by the financial delegations, is submitted to the French Parliament. The estimates for 1922, comprising both ordinary and extraordinary revenue and expenditure, amounted to 595,000,000 francs.

The northern portion of the territory is administered under two systems, one civil and the other military. In the civil zone the administration is that in force in France. This zone is divided into three departments, Oran, Algiers, and Constantine, with prefects, general councils and sub-prefects as in France. Each department elects two deputies and one senator to the French Parliament, only French citizens having the right to vote. The military zone is divided into three administrative regions, under the control, subject to the governor-general, of generals of division. These regions are cut up again into sectors administered by officers of the Department for Native Affairs. In accordance with the composition of the population, three methods of local administration are employed. In the "full" communes there are municipal councils, elected by the townspeople; in the "mixed" communes public services are run by an administrator, assisted by a non-elected municipal council; the "native" communes are ruled by kaidis with the assistance of native advisers, who are appointed by the governor-general.

The colonization of Algeria was rendered difficult by the presence of a native population which already had its own civilization, and was nomad and warlike in its instincts. A start was made in the region of the Tell, and then the mountains and high plateau-lands were taken in hand. There has been a spontaneous flow of Italian and Spanish immigration, and a system of land grants and other concessions have attracted large numbers of immigrants from the south of France who have settled down well in the country. Between 1904 and 1914, 206,000 hectares of land had been settled, of which 91,200 were free grants.

*Agriculture* has made great strides in spite of the difficulty of irrigation. By a judicious system of barrages and canals, the torrential rains have been harnessed up and spread over the land. Much has been done also to fight the locust, and to carry out a methodical policy of manuring. The results obtained have been brilliant. In the Tell wheat and wine are grown on a large scale, and indeed

Algerian wine has become a serious competitor with French wine. In 1920 Algiers exported 2,729,551 hectolitres of wine, of which 2,418,726 went to France. The crop of cereals, which fluctuates very much in consequence of the variable rainfall, gave in 1914, 18½ million metric quintals; in 1915, 20 million; in 1916, 18 million; in 1917, 15 million; 1918, 30 million. Olive plantations produce about 300,000 hectolitres of oil a year. Vegetables, fruit, medicinal plants and cork are the other chief agricultural products of the Tell. Cotton is grown in the Oran and in Algiers, and great efforts have been made to increase the output of tobacco, of which over 24,000 tons were produced in 1918. On the tablelands the chief produce is alfalfa, which covers great areas. It is exported in very large quantities to Great Britain, where it is used in the manufacture of good quality paper. The alfalfa exports in 1916 were 811,997 quintals; in 1918, 118,900 quintals; and in 1920, 539,821 quintals, of the value of 12½ million francs. Sheep form the chief stock of the country. Forests cover well over two million hectares, the Woods and Forests service alone having that area under its control. Cork trees cover over 400,000 hectares.

*Minerals*.—The country is rich in minerals, which, however, have not been thoroughly exploited. The chief mineral resource is iron, the exports of which in 1920 amounted to 1,114,438 tons, valued at 33,879,000 francs. There are large phosphate deposits in the Constantine province, which exported 334,704 tons in 1920 to a value of 18½ million francs. There are also copper, zinc, lead, and antimony mines. Coal deposits were discovered during the war, and the work of British and American prospectors in the Oran indicates the possibility of existence of oil fields of some size. In 1900, Algeria possessed only 1,771 m. of railway; that figure had by 1921 been brought to 2,228, and many new lines were being considered. The three chief ports handled the following traffic in 1920: Algiers, 6,264,735 tons; Oran, 3,975,762 tons; Bona, 1,106,362 tons. A great deal of work has been done in improving the road system of the country, and motor-ways have been built from Tuggurt to Timbuktu. An aerial postal service has also been organized.

*Commerce*.—The general trade in 1920 amounted to 4,342,000,000 francs, and special trade, that is to say, trade arising exclusively from the requirements and produce of the colony, amounted to 3,977,000,000 francs, of which 2,535,000,000 were imports, and 1,442,000,000 exports. Of this trade, France took respectively 1,991,862 francs, and 1,096,472 francs. These figures show a very large increase, the general trade in 1918 amounting only to 1,520,000,000 francs, and in 1919 to 2,287,900,000 francs. In 1913, the last normal year before the war, the figure was 1,292,000,000, of which 729,000,000 were imports, and 563,000,000 were exports. In judging of these figures, the drop in the value of money has to be borne in mind.

*Native rights*.—The valuable help given by the native population of Algiers to France during the World War led, as it did in other parts of the French colonial empire, to a wider recognition of the political rights of the native. A law was passed, Feb. 4 1919, conferring French citizenship on any native of Algeria who had either served in the French army or navy, was a land-owner, farmer, or licensed trader, knew how to read and write French, or was the possessor of a French decoration. Native Mussulmans who did not receive French citizenship, are represented in all the deliberative assemblies by elected members who sit with the same rights as those enjoyed by the French members of such assemblies. With some exceptions they are admitted to public service on the same footing as French citizens. In the beginning of 1919 the special Arab taxes, which were supported by the native population alone, were done away with, and their place was taken by income and property taxes. It was proposed to form an Algerian consulting committee in Paris, in which natives would sit. (M. R.)

**ALLBUTT, SIR THOMAS CLIFFORD** (1836— ), English physician, was born at Dewsbury, Yorks., July 20 1836. He was educated at St. Peter's, York, and Caius College, Cambridge, where he took a first class in the natural science tripos in 1860. He studied medicine at St. George's Hospital and afterwards in Paris, subsequently practising in London and Leeds. He carried out many researches on the pathology of the nervous system, and made important studies of tetanus and hydrophobia. He also devoted much time to the study of ophthalmology, and was the inventor of the short clinical thermometer. He was consulting physician to many institutions, and from 1889 to 1892 was a commissioner in lunacy. In 1892 he became Regius professor of physic at Cambridge, and in 1907 was created K.C.B. Sir Clifford Allbutt was a member of many Government committees, including the Home Office inquiry into trade diseases, and during the World War he was an hon. colonel in the R.A.M.C.

His published works include *The Ophthalmoscope in Medicine* (1871); *On Scrofula* (1885); *Diseases of the Heart* (Lane lectures, 1896); *Historical Relations of Medicine and Surgery* (1905); *Greek Medicine in Rome* (Fitzpatrick lectures, 1909-10); *Diseases of the Arteries and Angina Pectoris* (1915) and *Science in the School*

(1917). He also edited *Systems of Medicine and Gynaecology* (1896, 1899, 1907).

**ALLEN, SIR JAMES** (1855— ), New Zealand statesman, was born in South Australia Feb. 10 1855, and went to New Zealand about 1858. He was educated at Clifton College and St. John's College, Cambridge, where he held a natural science exhibition. At Cambridge he played in the University Rugby football fifteen and took his M.A. degree; and he afterwards studied at the Royal School of Mines and won the Bessemer and de la Beche medal. In 1887 he made a remarkable entry into politics by winning the Dunedin East seat from Sir Robert Stout, then Premier and Liberal leader, by 19 votes. Losing this seat at the general election of 1890, he represented Bruce from 1891 till his resignation in 1920. He has always taken a special interest in educational, military and imperial questions; was a member of the Otago University council and served a term as chancellor; and from 1908-12 was a member of the New Zealand University senate. He was for many years an enthusiastic volunteer, and was promoted Lieutenant-colonel in 1902.

During the 21 years of Mr. Allen's service in opposition he showed himself a keen critic of the Liberal administration, especially on financial matters. On defence questions he always spoke with authority and without party bias. The movement for compulsory military training, which came to a head in 1909, had his hearty support, and it is certain that the extension of the Territorial age-limit from the 22nd to the 25th year, which Lord Kitchener recommended, could not have been carried by the Ward government in 1910 without the help that Mr. Allen gave to it. When the Reform party came into power in 1912 Mr. Allen became Mr. Massey's right-hand man. He held the three onerous portfolios of Defence, Finance, and Education in the first Massey administration (1912-15). His prudence and caution inspired confidence in his budgets, and both in military and in naval defence he gave the country a strong lead. His proposal in 1913 to organize an Expeditionary Force of 8,000 men for overseas service was severely criticised, but its value was duly appreciated in the following year. Regarding naval defence he insisted strongly on the inadequacy of a mere cash payment to the Admiralty to discharge the obligations of a self-respecting state, and with Mr. Massey he laid, in the Naval Defence Act, 1913, the foundations of a policy of self-reliance, with the proviso that the Dominion's naval forces should automatically pass into the control of the Admiralty in time of war.

As a member of the National Government which was formed as a result of the Massey-Ward war coalition Sir James Allen retained the portfolio of Defence, and he held it throughout the life of that Government (1915-9) and until his retirement from the succeeding Massey government in March 1920. It is impossible to exaggerate the value of his services in that capacity. He faced all the problems of organizing a young and untried democracy for the World War, first under a voluntary and then under a compulsory system, with a resolution that never faltered, and he saw it through. During the first year or two of the war the Defence Minister was probably the most unpopular man in the Dominion, but there was afterwards a strong reaction in his favour, and towards its close the sterling value of his services was universally recognized. There was certainly no other man to whom the Dominion was more deeply indebted for the excellence of its war record.

During the long absences of Mr. Massey and Sir Joseph Ward on the business of the Imperial War Cabinet in 1916, 1917 and 1918 and of the Peace Conference in 1919 Sir James Allen had the responsibilities of Acting-Prime Minister as well as those of Defence. He retired from politics in 1920 in order to succeed Sir Thomas Mackenzie as the Dominion's High Commissioner in London on July 31. Few statesmen who have so persistently violated the politician's rule of putting all the best goods in the front window have been privileged to retain the confidence of a democracy so long and to render it such admirable service. He was made a K.C.B. in 1917. He married Mary Hill Richards of Somerset, England, in 1877 and has two sons and three

daughters. His younger son, John Hugh Allen, was killed in action at Gallipoli.

**ALLENBY, EDMUND HENRY HYNDMAN ALLENBY**, 1st Visct. (1861— ), British field marshal, son of Hyndman Allenby, was born April 23 1861, and joined the Inniskilling Dragoons in 1882. His first few years in the army were spent in South Africa, where he took part in the Bechuanaland expedition of 1884-5 and in the Zululand operations of 1888. After returning to England with his regiment he passed through the Staff College and in 1896 he married Adelaide Mabel Chapman. He went out to South Africa again as a squadron leader in 1899 and took part in the important cavalry operations by which Kimberley was relieved, in the battle of Paardeberg, and in Lord Roberts's advance to Pretoria and into the eastern Transvaal. During the later phases of the South African War he made a great name for himself as a column commander, and he was for his services promoted brevet lieutenant-colonel and colonel and given the C.B. He then commanded the 5th Lancers from 1902-5 and for the next four years he was at the head of a cavalry brigade, being promoted major-general in 1909. He became inspector of cavalry in 1910 and, as holding that position, went out to France with the Expeditionary Force in 1914 in charge of the cavalry division.

The work of his mounted troops during the retreat from Mons, the subsequent advance to the Aisne, and the first battle of Ypres won great praise, and on a second cavalry division arriving Allenby was appointed commander of the newly constituted Cavalry Corps. He was about the same time given the K.C.B.; in June 1915 he was transferred from this to the command of the 5th Army Corps; but he held that position for only a short time as, in the following Oct. on Gen. Monro's proceeding to the Near East, he succeeded that general as chief of the 3rd Army<sup>1</sup> which he led for nearly two years. His army was not called upon to undertake operations on any large scale during 1916, but it shared to some extent in the later stages of the battle of the Somme. In 1917, on the other hand, it was very heavily engaged in the Arras region during the spring months and won much valuable ground. Allenby had been promoted lieutenant-general in 1916, and in June 1917 he was selected for the command of the troops in Egypt and Palestine, where elaborate preparations had been made for an offensive campaign; he was at the same time promoted general.

The season was unsuitable for active operations on the borders of the Holy Land for the first three months after his arrival in Egypt, but these were spent in perfecting preparations for an advance, which began at the end of Oct. with the capture of Beersheba and the taking of Gaza a few days after. These successes were followed up relentlessly. Jaffa fell Nov. 17; the Turks were driven with loss out of every position that they tried to take up, and, after vain efforts on their part to bar the way to Jerusalem, that city was surrendered Dec. 9. Allenby, who had been given the G.C.M.G. for these achievements, materially improved his position during the next four months, but he was then obliged by events in France to despatch some of his troops to the western theatre of war.

During the summer of 1918 fresh forces from India and Mesopotamia took the place of the troops sent away, and in Sept. the British commander struck with crushing effect. By a sudden advance in great force the Turkish front was broken, the plain of Edræelion was flooded with mounted men, the infantry moved irresistibly forward and, as the result of a masterly combination of war, the enemy suffered an overwhelming defeat. All arrangements had been made in advance for instantly following up the anticipated victory; within a very few weeks Damascus and Beirut had been occupied, troops had been thrust right up to Aleppo, and not only Palestine but also all Syria were in the hands of the Allies. Allenby's brilliant services were recognized by his being given the G.C.B., and, on the general distribution of honours for the war in 1919, he was promoted field marshal and was raised to the peerage as Viscount Allenby of Megiddo and Felixstowe; he was at the same time awarded a grant of £50,000.

While engaged in his campaigns of conquest, beyond the Egyptian borders Allenby had also been responsible for maintaining order in the Nile delta and for its protection against attack from without, matters that had at times given grounds for anxiety as there was much unrest due to the abnormal situation that existed. In 1919 he was definitely appointed British High Commissioner in Egypt.

**ALLENSTEIN-MARIENWERDER**, a region composed of districts of the former Prussian provinces of East and West Prussia, in which a plebiscite was taken, under the Treaty of Versailles, on June 11 1920.

Art. 94-98 of the Treaty of Versailles provided that the East Prussian Circles (Kreise) of Allenstein, Osterode, Ortelsburg, Sensburg, Johannisburg, Lötzen, Lyck and Neidenburg, in so far as they had not already been ceded to Poland, and further the West Prussian Circles of Marienwerder (east of the Vistula), Stuhm, Rosenberg and the section of the Circle Marienburg situated east of the Nogat, should declare by a plebiscite whether they desired to belong to Germany or Poland. Until the plebiscite should take place the administration of these Circles was taken over by interallied commissions for East and West Prussia respectively. The commissions were composed of representatives of England, France, Italy and Japan. Troops for occupying the districts were provided by France, England and Italy. Two German commissions conducted the negotiations with the interallied commissions.

The whole territory has an extent of about 15,000 sq. km., and a pop. of about 855,000, of which 695,000 belong to the East Prussian plebiscitary area and 160,000 to the West Prussian. Racially the population in the East Prussian region numbers 428,000 Germans, 95,000 Poles and 172,000 Masurians, who are Slavs but of the Protestant faith. In the West Prussian region the Circle Stuhm has 21,000 inhabitants who speak German and 15,000 who speak Polish; the Circle Marienburg has 26,500 German-speaking and 1,500 Polish-speaking; Rosenberg 47,000 German-speaking and 3,500 Polish-speaking; Marienwerder 17,500 German-speaking and 25,000 Polish-speaking inhabitants.

The date of the plebiscite was fixed originally for June 11 1920. Long before that date a vigorous agitation was opened by both sides. There were repeated actual encounters in different places, mostly excited by Polish bands, the so-called *Bajonkas*, recruited from Congress Poland, and the territory of Posenia which has been ceded under the Treaty. The Polish agitation, however, did not produce any marked results either in West Prussia or in East. In both regions leagues which agitated for Poland were from the native Polish and Masurian elements of the population, but in the course of the plebiscitary campaign they went over to the Germans. The plebiscite, ultimately held on July 11, resulted in an astonishing German victory.

In the East Prussian region 98% of the population voted for Germany, in the West Prussian 92%. The result was celebrated by joyous festivities in all the East and West Prussian polling centres. Both the districts were assigned to Germany on the basis of the vote; but, in accordance with the terms of the Treaty of Versailles, a zone 50 m. broad and some 30 m. long on the east bank of the Vistula near Marienwerder and four villages with the harbour of Kurzebrack on the same river were assigned to Poland in order to secure for the Polish State, at this point, the sovereignty over the course of the Vistula accorded to it by the Treaty. The inhabitants of the adjacent East Prussian territory are at all times to have access for themselves and their boats to the Vistula. Three frontier communes in the south-west of East Prussia were also assigned to Poland. On Aug. 16 both the interallied commissions left the plebiscitary areas, which were thus once more subjected to German administration. The agitation in favour of Germany had been to a considerable extent conducted by the so-called *Heimatsdienst*, a patriotic German society which had spread its organization over the whole of the plebiscitary areas.

(C. K. \*)

**ALMA-TADEMA, SIR LAURENCE** (Laurens) (1836-1912), British painter (see 1.712), died at Wiesbaden June 25 1912. The most important of his later works was "Caracalla and Geta" (1907). An exhibition of his works was held in London 1913.

**ALPHONSO XIII.** (1886- ), King of Spain (see 1.736). On returning from a military review April 13 1913, an attempt against the King's life was made by an anarchist, who shot at him but only succeeded in wounding the horse. The children born to the King are: Alphonso, Prince of the Asturias, May 10 1907; Jaime, June 23 1908; Beatriz, June 22 1909; Maria Cristina, Dec. 12 1911; Juan, June 20 1913; Gonzalo, Oct. 24 1914. During the World War the King, as ruler of a

neutral country, though scrupulously preserving a neutral attitude, rendered great services to the Allies by his intervention on behalf of prisoners of war and his efforts to ascertain the fate of men reported "missing." (See further SPAIN.)

**ALSACE-LORRAINE** (see 1.756).—As the result of the World War there is no longer any "Alsace-Lorraine." The erstwhile *Reichsland*, conceived by Bismarck in 1871, ceased to exist in Nov. 1918. As before 1870, there are now again the French departments of the Bas-Rhin (Strasbourg), the Haut-Rhin (Colmar) and the Moselle (Metz). The return of the former Alsace-Lorraine to the French mother-country took place amidst the indescribable pleasure of the restored populations.

In 1921 the three departments were passing through a transition period. The Germans did not occupy the country for nearly half a century without trying to leave their mark on it, without introducing their administrative methods and laws, which sometimes differ completely from those of French administration and legislation. The Government in Paris came to the conclusion that to transplant the reconquered provinces in a day from German to French ways would be to risk confusions and upsets which it would be preferable to avoid; it was thought that there was a considerable work in legislative assimilation, adaptation and adjustment, to accomplish. It was for this reason that after the Armistice a High Commission of the Republic was established at Strasbourg, comprising many departments and many different services. The General Commission of the Republic is directly attached to the prime minister's office, the affairs of the three departments being centralized in the hands of the under-secretary of the presidency.

The first High Commissioner, M. Georges Maringer, was replaced in April 1919 by M. Alexandre Millerand, who went to Strasbourg with extended powers, and the title of General Commissioner. Called in Jan. 1920 to the premiership of France, M. Millerand had as successor M. Gabriel Alapetite, former resident-general for France at Tunis, and ambassador at Madrid.

**Administration.**—The general lines upon which French legislation was to be introduced were fixed by the law of Oct. 17 1919, concerning the transitional administration of the recovered provinces. This law settles the transitional methods to be applied to administrative, electoral and financial organization. On the other hand, constitutional laws are not dealt with, because they are *ipso facto* applicable by the reintegration of Alsace and Lorraine with France.

The law of Oct. 17 1919 maintains in force the legislative arrangements and local regulations (German law or special Alsace-Lorraine law) until the introduction of French laws shall have been effected. The authority of the military governors of Strasbourg and Metz is subordinated to the civil power. Article 4 of this law lays down in principle that it is for Parliament to decide what temporary measures shall be introduced pending the definitive introduction of French legislation. The same law establishes that the French fiscal system shall gradually be substituted for that of Germany. The electoral system is that of France. The former Alsace-Lorraine has kept certain laws passed during German rule; for instance, the laws affecting social insurance. In religious matters, the Republican Government has respected the *status quo*—that is to say, the Concordat is maintained, also the denominational schools.

It is abundantly apparent that the Government is keeping the solemn promise made during the war by French statesmen and generals to the effect that the customs and beliefs of the people would be respected. The mission of the Commissioner-General is extremely delicate. He has departmental responsibility in these three departments unknown in others. He has to determine how, in what length of time, and with what precautions French laws can be successively applied there. In submitting legislation, he has to inform Parliament as to the gravity of the disturbance which changes must make in settled habits and customs, and as to the difficulties accompanying the return to French rule.



A consultative council has been provisionally instituted in connexion with the High Commission of the Republic. It comprises 35 members, of whom 3 are senators, 6 deputies, 21 local councillors, and 5 named by the decision of the prime minister. This body deliberates and pronounces upon all questions which fall outside the limits of any one public department, and are submitted to it by the Commissioner-General. It is *compulsorily* consulted on the budget of revenue and expenditure in Alsace-Lorraine and on all proposed modifications of the fiscal system in force; as also on all administrative or economic bills and regulations affecting the combined populations of the three departments. The consultative council is convoked by the Commissioner-General at least four times a year. Thus the Commissioner-General has at hand a body in which the representatives of the different populations can show forth the interests of these latter and, by expert advice, can facilitate the study and solution of questions common to the Haut-Rhin, the Bas-Rhin, and the Moselle. But this body is purely consultative. The Government of the Republic keeps its power of initiative and its responsibilities; Parliament remains the sovereign power.

**Population.**—The recovered departments are administered like the other French departments. The department of the Bas-Rhin (*prefecture* Strasbourg) includes 8 *arrondissements*: Strasbourg-Ville; Strasbourg-Campagne; Erstein; Haguenau; Molsheim; Sélestat; Wissembourg; Saverne. Its superficial area is 4786·37 square kilometres. There are 561 *communes*. The pop. numbers 668,116. The department of the Haut-Rhin (*prefecture* Colmar) includes 6 *arrondissements*: Altkirch; Colmar; Guebwiller; Mulhouse; Ribeauvillé; Thann. Area 3,507·7 sq. km.; 386 *communes*; pop. 430,988. The department of the Moselle (*prefecture* Metz) includes 9 *arrondissements*: Moselle-Ville; Moselle-Campagne; Boulay; Château-Salins; Forbach; Sarrebourg; Sarreguemines; Thionville-Ouest; Thionville-Est. Area 6,227·8 sq. km.; 758 *communes*; pop. 554,445. The combined population according to the census of March 6 1921 is, therefore, 1,593,549, as against 1,874,014 at the time of the last German census in 1910.

The falling-off in the number of the population can be attributed in the first place to the war. Alsace and Lorraine had lost in dead and missing about 45,000 men. Moreover, militarist Germany kept in the three departments no less than 82,276 soldiers. The German and Austro-Hungarian subjects domiciled in Alsace and in Lorraine before the war numbered 301,754. The number of German civilians who had left Alsace and Lorraine after the Armistice up to April 1 1921 was 76,467. These departures were partly balanced by the fact that many French subjects from the home country settled in the recovered provinces.

Before the war there were in the imperial territory 1,428,343 Catholics, 408,274 Protestants, 30,483 Jews. The percentage of illegitimate births was 7·52. In 1921 in Strasbourg there were 165,833 inhabitants; in Mulhouse 98,393; Sarreguemines 14,318; in Thionville 13,410; in Guebwiller 11,520; in Forbach 10,475; in Sélestat 9,846; in Ste. Marie-aux-Mines 9,395; and in Sarrebourg 8,290.

**Agriculture.**—Agricultural production in 1920 amounted to 160,735 tons of wheat, 57,351 tons of rye, 71,829 tons of barley, 126,437 tons of oats, 1,025,424 tons of potatoes, 44,174 tons of sugar-beet. Alsace provided one-eighth of the whole world production of hops: the crop of 1920 amounted to 3,355 tons. The wines of Alsace are nearly all white wines, of an exquisite flavour and bouquet, yielding nothing to the German wines of the Moselle and the Rhine. Rich in alcohol, they are very suitable for export. The Moselle produces in particular *vin gris* and red wine. The vintage of 1920 reached 725,000 hectolitres as against 734,000 in 1919. The value of the 1920 vintage was 124,000,000 frs. The average tobacco crop is 4,000,000 kilograms.

**Mineral Wealth.**—While petroleum and potash are found in Alsace the Moselle is rich in iron ore and coal. The oil lands stretch out to the E. of Woerth (Wörth) in the Bas-Rhin, where the Pechelbronn field is situated. Between 1913 and 1921 about 5,000 borings were made and over 500 pumps were installed in this field. The average output during 1918-9 was 49,225 tons. The total yield up to 1921 had been about 900,000 tons, and the available supplies were estimated at 5½ million tons. Oil refineries with a treatment capacity of 73,000 tons a year have been built at Pechelbronn. The State acquired these deposits in 1921, and handed over their exploitation to a private company, mainly formed by local interests.

The return of the department of the Upper Rhine to France deprives German industry of the monopoly of potash. Potash was discovered in large quantities in 1904 in Alsace by the Alsatian

Vogt. The area concerned covers about 300 sq. km. of country and to the N. of Mulhouse. The output for 1919 was 512,000 tons and for 1920 1,222,609 tons. This represents an increase of 249% over the last pre-war figures. An annual yield of between five and six million tons was expected before long.

By the liberation of Alsace-Lorraine France became the largest European producer of iron ore, with an annual yield of 42 million tons. There are 55 mines in Lorraine. Output reached its height in 1913 with 21,133,676 tons, a downward curve being shown by later figures, which are as follows:—

Year	Tons
1914	14,014,137
1915	10,754,351
1916	13,286,302
1917	13,614,139
1918	10,477,573
1919	7,137,206

After the Armistice there was a steady drop in output, due to post-war difficulties of all kinds: the year 1919 was for the whole field a period of reconstruction. Output between Jan. and Sept. 1920 amounted to six million tons. The mines employed 17,237 men in 1913 compared with 9,523 in 1919. In 1913 German labour was 60% of the total, in 1920 it was 32·2%.

The output of coal also reached its maximum in 1913, the figures being:

Year	Tons
1913	3,795,262
1914	2,856,732
1915	1,960,936
1916	2,027,684
1917	2,636,822
1918	2,662,046
1919	2,310,589

The fresh fall in 1919 was due to strikes and the reduction in working hours. Seven-tenths of the coal is consumed by local industry. The Lorraine salt mines produced 28,822 tons in 1919 as compared with 59,091 tons in 1913.

**Public Instruction.**—Strasbourg University was opened by President Poincaré on Nov. 22 1919. By the end of 1920 the six faculties and the Pharmaceutical School had 1,889 students. The lectures are given in French.

Secondary education is provided by the many *lycées* created throughout the country. French naturally is the chief language, but German has been allowed to have the place which is its due in view of the special situation of the provinces.

The language question has been more difficult to solve in primary schools. Before 1870 France had neglected the importance of teaching French in the primary schools of Alsace. Since 1920 the teaching has been in French throughout the country. An exception is however made for religious teaching (4 hours a week) which is given in German in those districts where the Alsatian dialect is the mother-tongue of the inhabitants. The religious character of schools has been respected. In view of the bilingual character of the country a large amount of time is given to the study of German in schools. The population is very well educated. Before the war there were only eight illiterates among the contingent of army recruits (97,604).

**Industry.**—After 1880 Alsace-Lorraine had been turned industrially towards Germany. In 1914 Alsace-Lorraine exported 1,576,000 tons of goods, 908,000 tons of which went to Germany. In 1909 eight out of ten and a half million tons of exports went to Germany, while nearly five-sixths of Alsace-Lorraine imports came from Germany. The preponderant part of Germany is naturally explained by the fact that while trade was free with Germany it was impeded with France by the customs wall. It is not possible by a stroke of the pen to change the commercial orientation of a country nor to find at once new markets for its products. Therefore the Treaty of Versailles laid down that for a period of five years nothing should be changed from the customs point of view in the relations between the recovered provinces and Germany.

In Alsace the textile industry is by far the most important, especially in spinning, weaving and printing. France, thanks to the restoration of the province, finds her productive power increased by 26% in spinning and by 30% in weaving. Large quantities of sewing and embroidery thread are also produced.

In Lorraine iron and steel industries are at the head. There are 68 furnaces with an annual capacity of 3,800,000 tons of pig-iron. The production fell from 3,460,000 tons in 1913 to 1,129,000 tons in 1919. The steel output in 1913 was 22,260,000 tons and in 1919 it had fallen to 871,000 tons. This drop is to be attributed entirely to coal and coke shortage. There were 22,000 workmen employed by the industry.

**Communications.**—The railway system is excellent and had been developed greatly by the Germans, mainly from a strategic point of view. The railways have preserved their autonomy and constitute a special system attached to the Ministry of Public Works. In 1920 the traffic amounted to 2,253,000,000 tons of goods.

The canal system is good, but the great waterway is naturally the Rhine. The port of Strasbourg with its modern equipment is the



chief French eastern port. It handled 1,324,177 tons of goods during the first ten months of 1920.

Generally, the liberated provinces are among the richest of France. Deposits in savings banks in 1919 amounted to 462,281,426 francs. The best figure during the German occupation was 289,084,450 marks.

There were no foreign consuls in Strasbourg during the period of Germany's occupation. Since the Armistice Great Britain, the United States, Belgium, Poland, Holland and Spain have established consulates there.

*History.*—There is no need, after the World War, in considering the rights of France to Alsace-Lorraine, to refer to the treaty of 1648, or to embark upon any misty historical researches in the period before the Treaty of Verdun of 1843. Documents and facts since the end of the Franco-German War of 1870 are sufficiently illuminating. Bismarck, on May 2 1871—that is to say, eight days before the signature of the Treaty of Frankfurt, declared:—"We could do nothing but take these territories with their powerful fortresses within the framework of Germany, so as to make of them a glacis of Germany against France." On Nov. 30 1875, he again gave expression to this idea of the glacis, saying to the Reichstag:—"We have conquered these territories in the interest of the empire, in the course of a good war, and a defensive war, in which we had to save our skins. It was not for Alsace-Lorraine that our warriors shed their blood, but for the German Empire, its unity, and the safety of its numbers. We have annexed these provinces so that Wissemburg shall not be the jumping-off place of the French in the next attack which they are planning, and which may God delay as long as possible. We have annexed these provinces so as to have a glacis . . ."

This brutal glacis-theory is also expressed in a confidential autograph letter, written by the Emperor William I., on Oct. 25 1870, in which the writer says:—"After having made immense sacrifices for her defence, Germany wants to be certain that the next war shall find her better prepared to beat back the attack which we will have to expect as soon as France has recuperated her strength, or found allies. It is this side consideration alone, and not the desire to aggrandize my country, which is big enough, which forces me to insist upon territorial cessions which have no other aim but to push back the starting-point of the French armies which will attack us in future." German writers and historians have declared that Germany fought in 1870 in order to regain the "old German land" of Alsace-Lorraine, which desired to return to the Germanic fold. The truth is much more simple, and is to be found in the words of Bismarck and the letter of his sovereign. The people of Alsace-Lorraine were treated as pawns, because the new German Empire wanted a glacis. The inhabitants of the two provinces protested through their elected representatives against the treatment to which they were subjected. On March 1 1871, the deputies of Alsace and Lorraine raised their voices against separation from France. In the solemn declaration made at the Assembly of Bordeaux they said:—"We have been handed over despite all justice and by odious abuse of force, to foreign domination, and we have one last duty to fulfil. Once again we declare that we consider as null and void a pact which disposes of us without our consent. The vindication of our rights shall forever be open to us in the form and measure dictated by our conscience. Your brothers of Alsace-Lorraine, now separated from the common family, will keep for France, banished from her hearths, filial affection until the day when France again returns to take her place." On Feb. 1 1874 elections were held in the Reichsland, and all the candidates who protested against the annexation were returned. On Feb. 18 they made a protest from the tribune of the Reichsland, in which they said:—"On behalf of the inhabitants of Alsace-Lorraine we protest against the abuse of strength of which our country is the victim. Although in distant and comparatively savage days the right of conquest may have sometimes become an effective right; although to-day it may still be justified when it is a question of ignorant and savage peoples, nothing of the sort can be justified with regard to Alsace-Lorraine. Germany has conquered us at the end of the nine-

teenth century, a century of light and progress; and the people which she has reduced to slavery is one of those in Europe with a most highly cultivated feeling for right and justice. Our heart is irresistibly drawn towards our French fatherland. In electing us our constituents have above all wished to proclaim their sympathy with France."

France signed the Treaty of Frankfurt, and although she always refused to accept the justice of the annexation of Alsace-Lorraine, she continued to honour her signature. The inhabitants of the two provinces, however, were bound by no signature, and their protest against their lot passed through three phases: active protest, 1871-87; passive protest, 1887-1900; legal protest, 1900-14. France took no official part in these movements, and it may be said that the rights of France to Alsace and Lorraine were kept alive by the inhabitants themselves. Germany crushed the country under a system of dictatorship until May 1902; and it was not until 1911 that Alsace-Lorraine was given a constitution, which, moreover, failed to satisfy any political party. Outwardly the situation was accepted, the inexhaustible riches of the country, especially the underground wealth, had been exploited by the Germans; industry, making a bound forward, had brought prosperity; but the relations between the inhabitants and their conquerors were governed by a purely utilitarian spirit which did not conceal the unbridgeable gulf between them.

In 1871 Alsace-Lorraine was considered as a glacis for the defence of Germany, and this same theory again found utterance in a different form on Oct. 9 1917, when Baron von Kühlmann, then Minister for Foreign Affairs, declared that Alsace-Lorraine was the shield of Germany.

The feelings of the inhabitants towards France were abundantly clear at the moment of the Armistice of Nov. 1918, and during the entry of the French troops to the capitals. On Nov. 12 1918, the Parliament of Alsace-Lorraine, elected by universal suffrage in 1911, transformed itself into a national assembly, and on Dec. 5 1918 the deputies, meeting at Strasbourg, made the following declaration:—"The deputies of Alsace and Lorraine greet with joy the return of Alsace-Lorraine to France. The National Assembly, faithfully interpreting the constant and unalterable desire of the people of Alsace-Lorraine, already expressed by its representatives at the Assembly of Bordeaux in 1871, solemnly declares that it holds as inviolable and indefeasible the right of the people of Alsace-Lorraine to be made members of the family of France." The president of the Assembly, the Abbé Delsaur, when the full declaration had been read, exclaimed "Le referendum est fait!" Four days later the President of the Republic, adapting M. Delsaur's historic remark, closed his speech by saying "Le Plébiscite est fait!" A year later, on Nov. 16 1919, the people of the restored provinces took part as Frenchmen in the general elections. These elections really constituted a plebiscite. All the different political parties had included in their programmes a statement with regard to the return of Alsace-Lorraine to France. The Socialist election declaration said:—"To-day in complete agreement with the whole population of Alsace-Lorraine, the Socialist party firmly and without restrictions supports the return of the country to France. The people of Alsace-Lorraine are, and intend to remain, French." The Radical proclamation contained this phrase: "We are French, France is one and indivisible, we are a part of France, we are flesh of her flesh." The Catholic and Democratic parties, in their joint manifesto, stated: "This electoral demonstration must be a resounding echo of that made by your fathers in 1871. To Europe and the world you must solemnly renew the expression of your firm and unshakable desire to be, and to remain, French." (P. B.)

ALTMAN, BENJAMIN (1840-1913), American merchant and art collector, was born July 12 1840 in New York City, and died there Oct. 7 1913. As a young man he became interested in early European paintings and in Oriental art. His collection of Chinese porcelains was among the finest and his Oriental rugs were remarkable. Of the works of Rembrandt,

whom he admired above all other artists, he possessed probably the largest private collection ever assembled. Velazquez was well represented, as were Van Dyck, Cuyper, Ruysdael, Vermeer, and many others. These collections he bequeathed to the Metropolitan Museum of Art, New York City. Shortly before his death he secured the incorporation of the Altman Foundation, established for the welfare of the employees of the department store of B. Altman & Co., of which he was the head, thus crowning a career long devoted to unobtrusive philanthropy.

**ALVERSTONE, RICHARD EVERARD WEBSTER**, 1st Baron (1842-1915), Lord Chief Justice of England (see 1.775), died at Cranleigh, Surrey, Dec. 15 1915.

**AMADE, ALBERT GERARD LEO D'** (1856- ), French general, was born at Toulouse Dec. 27 1856. He was the son of an officer and was educated at La Flèche prior to entering the army in 1876. From 1887, when he became French military attaché at Peking, his military experience was peculiarly varied, and included, besides his four years in China, service as military attaché with the British forces during the S. African War, three years as French military attaché in London, and finally, as a general officer, the command of the expeditionary force in the Moroccan campaign of 1907. On the outbreak of the World War, he was, in accordance with the prepared scheme of operations which assumed Italy as an opponent, placed in charge of the "Army of the Alps." This group, however, had only a momentary existence. It became clear that Italy would remain neutral. D'Amade's troops were taken to reinforce other fronts and he himself was placed in charge of a group of forces formed in the region of Lille and Douai to resist as best it might the unexpectedly wide sweep of the German invasion. Weak numerically, composed wholly of territorial units of the oldest classes, improvised in point of organization and ill equipped, D'Amade's "army" was in no condition to attempt a vigorous counter-offensive or even a fixed defensive, and after a certain amount of fighting in the Cambrai region it was withdrawn to the extreme left, between Amiens and Abbeville, Gen. Maunoury's VI Army taking its place. In the spring of 1915, when a French contingent was formed for service in the Levant, D'Amade was appointed to command it, and in this capacity led the French forces in the Dardanelles landing of April, and the trench warfare that followed. A gallant and knightly soldier, already experienced in the ways of his Allies, he was exceptionally well fitted to hold a command which, half subordinate, half independent, presented all possible opportunities of friction, and in fact few if any inter-Allied operations of the World War were conducted with so little friction as this. In May, however, he was recalled to France.

**AMERICAN LITERATURE** (see 1.831).—After the year 1910 the American novel developed mainly in the realistic manner, and in a rather remarkable way, the year 1920 being especially notable for the appearance of novels of distinction. The romantic revival in English and American fiction, which began in the last decade of the 19th century, had exhausted itself before 1910. It was succeeded by what might be called the "life" novel, where the entire history of the hero or heroine is given; even where this rather loose biographical method is not attempted, the realistic novels from 1910 to 1921 were marked by a fidelity to fact and a sincerity of composition which indicated promise for the future development of the art. Mark Twain and O. Henry died in 1910; Henry James in 1916; W. D. Howells in 1920. During recent years no one, either in the novel or in the short story, eclipsed the work of these men. But some important new writers appeared and two veterans showed increasing power. Booth Tarkington, born at Indianapolis in 1869, who had a wide reputation after 1899, began in 1914 a series of novels superior to anything in the preceding 15 years of his career. These later novels may be divided into two classes—those dealing with towns and those dealing with youth. In *The Turnout* (1915) and in *The Magnificent Ambersons* (1918) he analyzed and described life in American cities; in *Penrod* (1914) and in *Seventeen* (1916) he gave a faithful analysis of the character of the American boy and of the American youth; while in *Alice Adams* (1921) he por-

trays with subtlety a young girl. It should also be mentioned that his sympathetic portraits of negroes were among the best ever produced. Edith Wharton's *Age of Innocence* (1920) is her masterpiece; it is a novel dealing with New York society in 1872, valuable for its consummate art and for the accuracy of its historical pictures. The new novelists, unknown before 1910, deal—with the single exception of Anne Douglas Sedgwick, who lived in England—wholly with American life and character. Dorothy Canfield, born at Lawrence, Kan., in 1879, produced two novels, *The Squirrel Cage* (1912) and *The Bent Twig* (1915), the latter describing life in a university in the middle-west, as well as *The Brimming Cup* in 1921, a remarkable study of a woman's nature and the grounds of her marital happiness. Zona Gale, born at Portage, Wis., in 1874, took in *Miss Lulu Bett* (1920) a familiar subject and treated it with scrupulous sincerity. The same praise may be given to Sinclair Lewis, born at Sauk Center, Minn., in 1885, for his novel *Main Street* (1920). Mrs. Mary S. Watts, born in Delaware Co., O., in 1868, wrote a series of realistic novels of American life, of which perhaps the best is the *Rise of Jennie Cashing* (1914). Henry Sydnor Harrison, born at Swannee, Tenn., in 1880, produced one novel of unusual charm in *Queen* (1911), followed by another almost equally successful, *V. V.'s Eyes* (1913); his prolonged war service interrupted a promising career. Joseph Hergesheimer, born at Philadelphia, Pa., in 1880, won his way to the front rank of American novelists by the extraordinary beauty and distinction of his prose style; he was a master of English composition, as shown in *The Three Black Pennys* (1917) and *Javo Head* (1919). Another distinguished American writer was Anne Douglas Sedgwick, born at Englewood, N.J., in 1873, who lived in Europe from childhood. Her powers, both of analysis and of style, appear to especial advantage in *The Encounter* (1914) and *The Third Window* (1920), while her short story, *Autumn Crocuses* (1919), is perhaps the best piece of fiction produced by an American under the influence of the World War. The experimental school of fiction had a representative in Theodore Dreiser, born at Terre Haute, Ind., in 1871. His first novel, *Sister Carrie* (1900), is perhaps his best.

**The Drama.**—From the literary point of view the drama was not important. No play of universal significance has ever been written in America, yet the work of Clyde Fitch (1865-1900) was clever and original; his best plays illustrated very well metropolitan society at the beginning of the 20th century. Augustus Thomas, born at St. Louis, Mo., in 1850, wrote many plays of western life, but his masterpiece is *The Winking Hour* (1908). Booth Tarkington produced a successful and brilliant comedy, *Clarence* (1919). George M. Cohan, born at Providence, R.I., in 1878, had an astonishingly successful career as librettist, producer and actor, which was, on the whole, marked by a steady development; his play *The Taverer* (1920) was not only original, but had distinct literary merit. Louis K. Ansbacher, born at Cincinnati, O., in 1878, produced an excellent drama, both from the literary and theatrical point of view, *The Unchastened Woman* (1915). Eugene Walter, born at Cleveland, O., in 1874, showed talent for melodrama, and in one play, *The Easiest Way* (1913), for something higher. The death of Mark Twain made George Ade, born at Kentland, Ind., in 1866, the leading American humorist; his *Fables in Slang* (1900) struck a new note of humour and criticism; his plays, *The College Widow* (1904) and *Father and the Boys* (1907), exhibited a talent that the author did not choose to develop. He might have become the leading American playwright.

**Poetry.**—The World War had a powerful effect on the production of poetry, but a revival had set in about the year 1910, which in 1921 had shown no sign of abatement. The general interest in poetry and the immense number of young poets were notable phenomena; yet it is true that no great outstanding figure appeared—no one who for a moment could possibly rank with Poe, Emerson or Whitman. A leader in modern verse was Edwin Arlington Robinson, born at Head Tide, Me., in 1869, whose first volume appeared in 1896, but whose best work was certainly after 1910. In *The Man Against the Sky* (1916) and

*The Three Taverns* (1920) he combined bold, serious thinking with dignity and grace in expression. A poet who by example and precept stimulated both the love and production of poetry all over the country was Vachel Lindsay, born at Springfield, Ill., in 1879. He was the nearest modern approach to the mediæval minstrel. He tramped many hundreds of miles, paying for lodging and meals by chanting his own verses, many of which were written for oral effect. His four volumes of poetry, *General William Booth Enters into Heaven* (1913), *The Congo* (1914), *The Chinese Nightingale* (1917) and *The Golden Whales of California* (1920), contain works of melody, colour, and imagination. Robert Frost, born at San Francisco in 1875, wrote realistic verse mainly of country life in New England, of which *North of Boston* (1914) is typical. A quiet sincerity, a sharp observation, a steady but low fire of passion and imagination characterized his work. Edgar Lee Masters, born at Garnett, Kan., in 1869, suddenly achieved fame by *Spoon River Anthology* (1915). Intellectual vigour and irony are its distinguishing features. There is a poetical epitaph for each of nearly 250 persons, each distinctly portrayed, and usually with penetrating scorn. Anna Hempstead Branch was born at New London, Conn., and was a conservative poet, writing in the traditional way with high seriousness. She had passion and imagination and was at her best in poems of home-life. Amy Lowell, born at Brookline, Mass., in 1874, was remarkable as an experimentalist. Her versatility was extraordinary. She wrote much "new" poetry in free verse and in polyphonic prose; but she was equally fine in ballads and narrative poems, written in conventional metres. Perhaps her best book is *Sword Blades and Poppy Seed* (1914). Louis Untermeyer, born in New York in 1885, wrote many graceful lyrics, translated extensively from Horace and Heine, was an admirable parodist, and compiled an anthology, *Modern American Verse* (1919), which gave a fair review of the field. Among writers of parodies and composers of light verse after the manner of Calverley should also be mentioned Franklin P. Adams, born at Chicago in 1881. One of the foremost lyrical poets was Sara Teasdale, born at St. Louis, Mo., in 1884. None of her contemporaries surpassed her in the art of pure singing. Although Henry A. Beers, born at Buffalo, N.Y., in 1847, wrote sporadic verses all his life, his best volume is *The Two Twilight*s (1917) where his qualities of meditation and passion found full expression. Brian Hooker, born in New York in 1880, wrote notable sonnets and a powerful commemorative poem of the war, *A.D. 1919*. William Rose Benét, born in New York in 1886, had creative imagination, shown particularly in *Merchants from Cathay* (1918). His younger brother, Stephen Vincent Benét, born in Pennsylvania in 1898, was an extremely individualistic poet, with remarkable imaginative power, evident in *Heavens and Earth* (1920). Percy Mackaye, born in New York in 1875, published many poems and plays; his collected verse—which greatly varies in value—appeared in one large volume in 1916. Conrad Aiken, born at Savannah, Ga., in 1890, had the gift of singing speech, but his verse lacked thought. A representative volume was *Earth Triumphant* (1914). William Alexander Percy, born in Mississippi in 1885, was a lyric poet of high distinction, much influenced by classical studies. Students of free verse will find the extremes of the method represented in the works of Carl Sandburg, born at Galesburg, Ill., in 1878. His *Chicago Poems* (1916) are interesting for their local colour and aim. America lost two poets in the war, Joyce Kilmer (1886-1918), whose poem, *Trees*, seems destined to live, and Alan Seeger (1888-1916), whose posthumous volume had the stamp of genius. His lyric, *I Have a Rendezvous with Death*, was one of the most notable poems directly produced by the war. Many 20th-century poets are represented in the anthology called *The New Poetry*, edited by Harriet Monroe and Alice Henderson, published in 1917. The yearly anthology of magazine verse, chosen and edited by W. S. Brakhwaite, is a fair indication of contemporary production.

In miscellaneous literature from 1910-21, the most important work in history was the continuation of the *History of the United States* by James Ford Rhodes; a contribution to the

story of the development of the West was *A Son of the Middle Border* (1917) by Hamlin Garland; in scholarship, the continuation of the *Variorum Shakespeare* by the son of Horace Howard Furness; the most important and valuable biographical work was the *Life of Mark Twain* (1912) by Albert Bigelow Paine, followed in 1917 by the *Letters*; in epistolary literature the year 1920 was made memorable by the publication of the *Letters of Henry James* in the spring and those of William James in the autumn; the two best autobiographies of the period are *The Education of Henry Adams* (1918) and *The Americanisation of Edward Bok* (1920). The most important contributions to political literature were the addresses and state papers of Woodrow Wilson, President during 1913-21. In addition many books appeared dealing with various phases of the World War. Among such may be mentioned James W. Gerard, *My Four Years in Germany* (1917) and *Face to Face with Kaiserism* (1918); Bernard Baruch, *The Making of the Reparation and Economic Sections of the Treaty* (1920); Adml. William S. Sims, *The Victory at Sea* (1920); Brand Whitlock, Belgium: *a Personal Narrative* (1919); and Robert Lansing, *The Peace Negotiations* (1921). (W.L.F.)

**AMERY, LEOPOLD CHARLES MAURICE STENNETT** (1873- ), British politician, was born at Gorakhpur, North-West Provinces, India, Nov. 22 1873, and was educated at Harrow and Balliol College, Oxford. He was elected to an All Souls fellowship in 1897, and, after travelling for a year in the Near East, in 1899 joined the staff of *The Times*. He acted as chief correspondent to that paper during the South African War, and was also editor of *The Times History of the War in South Africa*. In 1906 he stood as a Unionist and Tariff Reformer for Wolverhampton East, but was defeated, being also unsuccessful in 1908 and 1910. He was, however, elected to Parliament for Sparkbrook, Birmingham, in 1911, retaining the seat at the election of 1918. From 1914 to 1916 he served with the army, first in France and later at Salonika, but in 1917 became assistant secretary to the War Cabinet, and from 1917 to 1918 was on the personal staff of the Secretary for War. In Jan. 1919 he became Under-Secretary for the Colonies, and during Lord Milner's absence in Egypt in the winter of 1919-20 was acting secretary. In 1921 he was appointed Under-Secretary at the Admiralty. He has published various works, including *The Problem of the Army* (1903); *Fundamental Fallacies of Free Trade* (1906); *The Great Question* (1909); *Union and Strength* (1912).

**AMIR 'ALI, SEYYID** (1849- ), Indian jurist and Moslem leader, was born April 6 1849, of an Arab family tracing descent from the Prophet, which migrated from Persia and settled at Mohan in Oudh in the middle of the 18th century. At Hugli College, Calcutta, he graduated in 1867, proceeding to his M.A. degree a year later. Receiving a State scholarship, he came to London and was called to the bar of the Inner Temple in 1873. He had already published *A Critical Examination of the Life and Teachings of Mahomed*, the first of a series of books of Islamic modernist interpretation and apologetics which have given him a recognized place in English literature, viz. *The Spirit of Islam* (1893), *Short History of the Saracens* (1899; third ed. 1921) and *Ethics of Islam* (1893). For some years a lecturer on Mohammedan law at the Presidency College, Calcutta, and afterwards president of the Faculty of Law at the university there, his textbooks on Mohammedan law and other legal works are marked by careful scholarship and characteristic lucidity. He was for some time chief presidency magistrate of Calcutta, but for the most part was engaged in practice, literature and non-official public affairs as a member of the Bengal Legislature and later of the Viceroy's Legislature until 1890, when he was appointed a judge of the Bengal High Court, being the first Mohammedan to reach the bench in India. Retiring in 1904 and settling in England, he was the first Indian to be sworn (Nov. 1909) of the Privy Council and to serve (unsalaried, but later with a small indemnity for expenses) on the Judicial Committee, where he gave the greatest assistance to his English colleagues in elucidating the intricacies of Indian law and custom. But his chief ambition in life was the advancement of the Indian Moslems, both morally

and materially, along practical and constitutional lines. While co-operating with Sir Seyyid Ahmad Khan (see 24,277) in overthrowing communal apathy and obscurantism as regards Western education, he deprecated his advocacy of detachment from political activity. His establishment in 1877 of the Central National Mohammedan Association, with branches throughout India, the memorial to the Government of India he promoted in 1883, and the consequent resolution of the Governor-General (Lord Dufferin) in Council in March 1885, recognizing the strength of the Moslem claims, constituted a turning-point in the history of the community, and paved the way for its fuller political organization and the reservation of Moslem seats in the legislatures under the Morley-Minto and subsequent reforms. His sustained and anxious interest in the maintenance of Moslem virility and influence throughout the world was shown by vigorous and cogent contributions to newspapers and reviews.

**AMMUNITION** (see 1.864-75).—The period of the World War witnessed important developments in the design of ammunition. Although the main effort was directed towards quantity production on a scale that no one had foreseen, and therefore to the simplification of manufacture, yet on the other hand fresh designs were constantly called for to meet changing tactical conditions. Air-fighting produced the need for "tracer" and incendiary bullets of rifle calibre and the attack of localities from the air developed the air bomb; with the free employment of thin armour-plate, armour-piercing bullets, radically different from the armour-piercing shell of artillery, became necessary; instantaneous fuzes designed to explode the shell just above ground came into general use for wire cutting; designs of grenades and trench-mortar bombs were brought out in profusion; and "chemical warfare" produced a varied ammunition which in principle was quite unlike ammunition of the customary kind.

Moreover, the needs of quantity production and in many cases the shortage of raw materials hitherto supposed to be essential to the production of projectiles and their cartridges, themselves led to novelties of design, and lastly in the attempt to increase the efficiency of older weapons brought out of the arsenals to tide over the shortage of artillery strength, the form of projectiles was revolutionized.

The subject of munitions of war collectively—the organization of the munition effort in the principal countries, with its political, social and industrial ramifications, is discussed in the article **MUNITIONS**. The present article deals with the technical characteristics of *Projectiles for Ordnance* (considered from the point of view of [a] design and purpose, [b] ballistic form and [c] manufacture); *Cartridges* (including ignition devices) and *Fuzes for Ordnance*; and *Ammunition for small arms and machine guns*.

(C. F. A.)

**DESIGN OF ARTILLERY PROJECTILES**

The normal modern shell, whether "monobloc" or made in parts and assembled, has the general form of a cylindrical steel body, hollow to receive the filling, with the base flat and the head pointed. Formerly the head was usually shaped with an ogive struck with radii equal to two calibres, or diameters of the body, from centres on a line through the shoulders of the shell. The shape of the fuzes was formerly not considered in relation to the contour of the shell; but when higher velocities were introduced, more attention was given to consideration of the contour of the fuzes, as an element of the head shape, to obviating "yaw" and to determining efficient shapes by means of experiments and empirical results derived therefrom.

In further connexion with high velocity, long range and accuracy, the shape of the head was made more pointed, being struck with radii of several calibres, though the shape did not remain truly ogival as the centres were not on the line through the shoulders of the shell. Greater range and accuracy are aimed at by making the outer contour of the rear part of the shell tapered or "stream-lined" (in America the term "boat-tailed" is used), and this again requires the head to be still more pointed, in order to compensate for loss of range due to lessened stability, since any stream-line, however small, necessitates the

driving band being placed further from the base than would be the case with a cylindrical body, and the supporting surface of the shell is diminished.

Besides the true stream-lined shell, that is one with the body itself formed with a fine point and taper base, there is another class known as "false-cap" shell which was first brought into use on a larger scale in the German artillery, and in which a body of normal form, or even not of projectile form at all is fitted with a long thin steel hood called a "false ogive" or false cap, or ballistic cap. This makes the shell in effect a 10-15 c.r.h. shell with its centre of gravity well towards the rear. During the World War this device, fitted to shells of older models, gave important increases of ranging power in all natures of forms in which it was applied, though the joint was not always strong enough or accurate enough to ensure the true centring of the projectile. The false cap is also found associated with the taper base in some cases.

Apart from ballistic efficiency, the design of a shell is largely determined by the stresses to which the projectile will be subjected on firing. The base must be of a strength sufficient to withstand the pressure of the propellant gases, and the walls of such a strength and thickness as will prevent fracture or distortion under the firing and rotating stresses.

The general trend of evolution during the war may be illustrated by comparing the characteristics of German naval shell designed before with those designed during the war. The former had thick walls and fairly small bursting charges, the head being struck with radii of less than 3 calibres and the total length being from 2½ to 3½ calibres. The latter on the contrary were made with thinner walls to contain a powerful bursting charge; the shape of the rear portion made stream-lined. The head was tapered to a point and usually struck with radii of 10 calibres; sometimes the head was formed by a false cap which in later types was welded to an adapter ring screwed into the shell proper. The total length was 4 to 5 calibres.

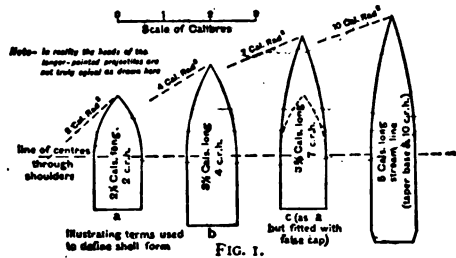

Figure 1, (which is purely diagrammatical) illustrates the general significance and relations of parts as measured in calibres.

The diameter of the body of a shell is slightly less than that of the "lands" of the rifled portion of the gun-barrel, this provides a clearance or "windage" that ensures the free passage of the shell down the gun-barrel. Pressed into a groove near the base of the shell is a band termed the rotating or driving band; it is larger in diameter than the rifled portion of the gun-barrel so that, on firing, as the projectile moves, this band taking the rifling gives the necessary spin to the shell to keep it point foremost in flight. In several instances in the German and Austrian services, two or even three driving bands have been put on to a single shell, the better to steady the shell during its passage through the bore of a gun.<sup>1</sup>

As a general rule the position of the band should be as near the base of the projectile as possible, it being found that the more rearward position of the band gives the most accurate shooting. On the other hand, a minimum distance of the band from the base is fixed by the minimum amount of material necessary for its support, for there is naturally a great strain thrown upon the shell when the band is forced into the grooves of the rifling and along their spiral, tending to tear off the base of the shell. Further, with stream-lined projectiles the band necessarily has to be placed far enough forward to clear the tapered base; and in Q.F. ammunition, where the projectile is carried fixed in the brass case, the band must be

<sup>1</sup> This is only possible of course if the twist of the rifling remains uniform; with "increasing" twist only a single driving band can be used. Fig. 10 shows three different German shells with two driving bands. (C. F. A.)

sufficiently forward to allow the projectile to be firmly secured in the case. The band must be rigidly secured to the projectile so that it will not become detached nor turn independently of the shell.

The material employed for driving bands should be soft enough for the band to be readily engraved by the rifling, even when using reduced propellant charges. Such material is of course easily dented, and as damaged driving bands lead to inaccurate shooting and increased erosion of the gun, care is necessary to ensure undamaged driving bands for service. If, on the contrary, the metal be too hard, it will throw an excessive strain on both projectile and rifling. For all these reasons copper ring, cut from a drawn tube and afterwards annealed, has been found to be the best and most suitable material. A cupro-nickel band has been employed with certain high-velocity medium guns using heavy charges. Electrolytic iron and bronze alloys have been experimented with; and during the World War, owing to the scarcity of copper, the Germans tried other metals, such as zinc and white metal alloys; and with two driving bands the upper was made of copper and the lower of zinc. The Germans also tried a novel combination in which the foundation of the band was a strip of ordinary carbon steel on which was a copper covering, the two metals being so adherent as not to be separated.

Copper bands have the drawback of causing so-called "coppering," particularly with high-velocity guns. As the projectile passes along the bore small particles of the copper band are detached and sweated on to portions of the bore of the gun; and if this surplus copper is allowed to accumulate, eventually a copper "choke" results, making that particular portion of the rifling smaller than the remainder, so that if windage is insufficient to accommodate it, either the gun must expand and bulge or the walls of the projectile set in. To get rid of copper choke it was formerly necessary to put the gun out of action and by chemical or electro-chemical processes dissipate the adhering copper. But recently it has been discovered that the copper deposit can be eliminated by using a small quantity of tin-foil between the propellant charge and the projectile; the alloy melts, being reduced to extremely fine particles which are deposited in the bore of the gun; and the tin combines with the copper to form a fusible alloy which is swept away by the next discharge. What are called "decoppering rings" have been tried attached to the shell. The Germans employed strips of alloys such as tin-lead and zinc-aluminium pressed into a groove round the shell.<sup>1</sup> Decoppering charges or rings would be employed after the gun has been warned by firing; and the gun must be absolutely free from grease or graphite material.

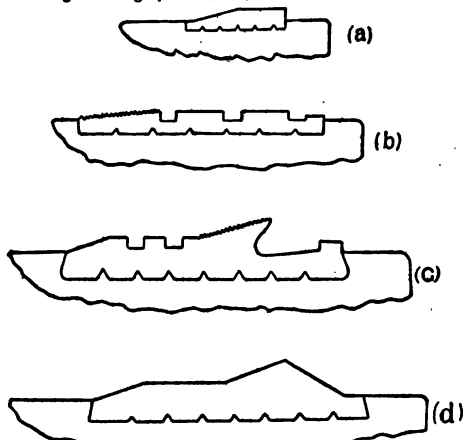

FIG. 2.

Generally the design of driving band as used by European continental powers, is a narrow strip somewhat rounded on top. In the British service the band is of a more elaborate shape. The first form of band (fig. 2, a) was narrow, flat on top and with a front slope so as easily to take the rifling, but excessive fringing of the copper caused the introduction of a broader and shallower band (b) with cannelures cut in it to give sufficiently with worn guns, a band with a gas-check (c) was introduced, in which an undercut lip was formed on an increased diameter towards the rear part of the band; this lip was readily expanded on firing and formed an effective seal

<sup>1</sup> Such decoppering rings will be seen in fig. 10 below the lower driving band in (b) and (c). (C. F. A.)

for the gas. For modern heavy high-velocity guns, driving bands with a greater body of metal are found necessary so as to give a better grip to the rifling; in such designs (d) a raised hump of metal is placed near the rear of the band. Before the war the tendency with medium types of guns was to have a broad band with but small depth of metal between the highest point of the band and the line of the shell; but this was modified during the war period in order to save copper, and to keep worn guns longer in use, by using a very narrow band of increased thickness.

In addition to the ordinary driving band, a band round the shoulders of a shell is sometimes used as a forward centring band to steady the projectile while passing through the bore of a gun. This band would not be of such a thickness as to be engraved by the rifling. The same result is obtained in many designs (see fig. 5a) by swelling out the metal of the shell to a distinct shoulder, sometimes known as a *bourrelet*. It requires, however, very accurate machining of the shell body at this point, and, probably for this reason, the use of a steadying band is more favoured on the continent of Europe.<sup>2</sup>

The weight of a shell is, to a certain extent, limited by its length and the stresses permissible on gun and carriage. With certain guns projectiles of different weights are used, and, provided that the difference in weight is not excessive, such shell when fired under similar conditions will have, at the muzzle of the gun, approximately equal energies, though they will range differently.

With different types of shell fired from the same gun, there must be a difference in length, to ensure that the weight of all the shell is the same. To ensure accurate shooting the shortest shell should be not less than two calibres in length; while on the other hand a very long shell introduces difficulties as it necessitates a sharper twist of rifling in the gun to give the requisite rotation, and thus imposes a greater strain on the gun. A very successful German shell for a light field howitzer was about  $4\frac{1}{2}$  calibres in length with centre of gravity about  $1\frac{1}{2}$  calibres from the base; and the head struck with about  $4\frac{1}{2}$  calibre radius; was stream-lined and weighed about 35 lbs.<sup>3</sup>

All modern shells are prepared to take a fuze for igniting the explosive in the shell (Sect. III. b.). Pointed shell (such as those intended for armour-piercing) for which the head must be retained intact, are fitted with base fuzes; other shells have the heads truncated and fitted to take nose fuzes. In addition to the fuze a "tracer" is sometimes employed in order to mark the trajectory while the shell is in flight. For night use, the tracer shows a luminous spark, for day use the tracer gives a smoky trail.

The natures of shell now used are:—(a) high-explosive, (b) shrapnel, (c) armour-piercing, (d) special shell of kinds such as smoke, star (illuminating), gas and incendiary.

(a) A high-explosive shell may be looked upon as a travelling mine, containing a large disruptive charge of high explosive. To obtain satisfactory results there must be full and complete detonation of the high-explosive bursting charge within the shell, otherwise the general effect will be small.

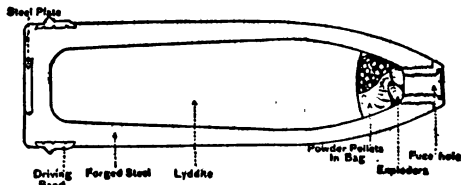

FIG. 3.

The body (fig. 3) is normally of forged steel with a solid base; a special steel plate is fitted in a recess in the base; and a socket screwed into the head, or the head itself is threaded to take a fuze which completes the point of the shell. If the shell body be of considerable thickness the explosive content is reduced; but on the other hand the shell body is stronger and there is thick metal for man-killing splinters. A thin-walled shell with a maximum explosive content on the other hand is adapted for the attack of material; with an instantaneous fuze it is useful for clearing ground of obstacles such as wire entanglements, and,

<sup>2</sup> A German shell with a steadying band is illustrated in fig. 10 (a). (C. F. A.)

<sup>3</sup> A useful approximate rule for comparing the weights of shells of different guns (similarity of shape being presumed) is:—half the cube of the calibre in inches is the weight in pounds. By this rule the weight of the shell just mentioned would be 34.5 lb. and that of a similar 5.9-in. shell would be 103 lb. (C. F. A.)

with a delay action, for the attack of buildings or dugouts. (A German example is shown in fig. 4.)

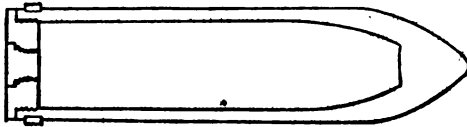

FIG. 4.

In the British service the explosives in general use for high-explosive shell are T.N.T. (tri-nitro-toluene, or troyl), a mixture of ammonium nitrate and T.N.T. known as amatol, and mixed in different proportions, and picric acid (lyddite). These explosives, especially amatol, are, under proper filling conditions, inert and safe substances, as they have to be if they are to sustain the shock of discharge from the gun. To ensure the necessary complete detonation therefore, an "exploder"<sup>1</sup>—in principle a small charge of less inert explosive—is interposed between the fuze and the bursting charge proper.

The British method of inserting the bursting charge is by melting the explosive in a hot-air chamber and pouring it, in liquid form, through a funnel into the shell. Filling through the base seems to be in favour in Germany; and the general method of filling is with one or more blocks of cast, or pressed, explosive enclosed in containers of varnished cardboard, linen or paper; a more uniform density of burster can thus be obtained. In some German H.E. shell the bursting charge is separated into two portions by a diaphragm which is pierced with holes for communication between the two charges. In every case a cavity is made in the centre of the filling, nearest the fuze, to receive the exploder which, being detonated through the medium of the fuze, in turn detonates the filling of the shell. Sometimes the relay element interposed between fuze and main bursting charge is contained in a "gaine" screwed to the fuze itself; the metal walls of the gaine confine the contents long enough to secure a good detonation and so a sufficient shock to the main charge. Between gaine and charge, if there is room, a small exploder is inserted to make contact intimate and the propagation of the shock more certain.

With 80/20 amatol, which in complete detonation gives practically no smoke effect, some smoke-producing mixture is included in the filled shell to assist observation.

The bursting charges for German H.E. shells are principally amatol of a mixture 13 to 87; frequently they are of troyl; and dinitrobenzene and tri-nitro-anisol have been used. Ammonal<sup>2</sup> and "ekrast" have been used in Austria. With the German 17-cm. H.E. shell the explosive is troyl stemmed in two containers, the exploder cavity being formed in the upper portion in which a brass exploder container is placed; with the 24-cm. H.E. shell two exploders are used.

A typical high-explosive shell is shown in fig. 5; the steel body is stout, giving great strength and thick metal for fragmentation; the amatol filling is in the form of blocks; the centre block is of T.N.T. which when acted on by the fuze and exploder, facilitates detonation and gives smoke to assist observation of fire.

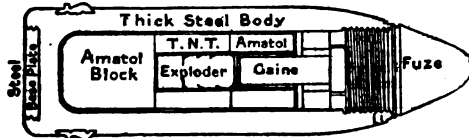

FIG. 5.

(b) *Shrapnel shell* is essentially a man-killing projectile; but shrapnel was employed during the World War for wire-cutting

<sup>1</sup> With lyddite fillings the exploder system takes the form of a bag of picric powder inserted in the cavity in the filling; the picric powder is readily ignited by a gunpowder-filled fuze and burns rapidly to detonation. With the other high-explosive fillings, particularly amatol which is difficult to detonate, the exploder is T.N.T. in crystalline form, inserted in small bags or cartons. Pellet exploders may probably take the place of exploder bags and cartons so as to give still more intimate contact between fuze and exploder. With T.N.T. exploders, as gunpowder-filled fuzes are not suitable, a detonating or high-explosive-filled fuze is employed.

<sup>2</sup> Ammonal was employed in the British service for trench-mortar bombs and for grenades, but not for artillery shell proper.

(C. F. A.)

and for long-range fire against observation balloons. In order to get as many bullets as possible to be packed into the shell, the walls are made as thin as is consistent with the shell body being able to withstand the firing and rotational stresses which act on it in the gun and during flight. With shrapnel fire, the normal practice is to open the shell in the air so as to release the bullets in a compact mass, their velocity at the moment of release being slightly accelerated by a small opening charge of gunpowder placed in a recess in the base of the shell below the bullets. To ensure the ready release of the bullets it is necessary to have either a separate and lightly attached head (in the heavier shell such as that in fig. 6), or a fuze socket held not too securely (in the lighter types fig. 5a), so that on the ignition of the small gunpowder charge in the shell, the head or the fuze-socket is readily blown clear and does not impede the release of the bullets.

The effect of a shrapnel shell depends on both the weight of the individual bullet and the number of bullets. To obtain high-striking energy—or rather to ensure a great depth of effect (this being defined by the point of burst of the shell and the point at which the released bullet ceases to possess adequate striking power)—the weight of each bullet should be kept as large as possible by the use of a heavy metal, viz. lead, hardened by an addition of antimony. The Germans used steel shrapnel bullets in some cases. On the other hand the larger the bullets the fewer of them a given shell will contain. The best compromise is obtained by making the bullets spherical and of a heavy metal. The bullets for British light field shrapnel run 41 to the lb., and for heavy field shrapnel 35 to the lb.; in special cases much heavier bullets are used.

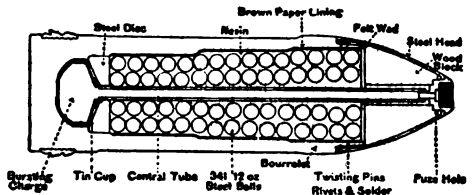

FIG. 5a.

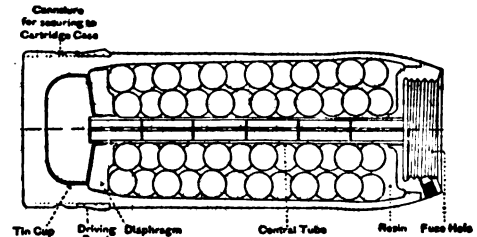

FIG. 6.

The shell consists in a light hollow steel body of which the walls increase in thickness slightly from the top to the base, near which the shell cavity contracts to form a ledge for the steel disc or diaphragm to rest on, and a chamber for the opening charge. The opening charge is usually of fine grain gunpowder, whose function is to force off the head or blow out the fuze socket with fuze, and drive out the bullets, which are thus carried forward with slightly accelerated speed as compared with the remaining velocity of the shell. The opening charge is placed in a tinned sheet-iron "cup" inserted in the recess in the base of the shell; the object of this "cup" being to prevent dangerous friction between the gunpowder and the rough interior of the shell. Resting on the shoulder above the tin cup is a steel disc, or diaphragm, which is screwed to receive a brass tube which occupies the centre of the shell. This diaphragm

<sup>3</sup> A compressed pellet of gunpowder has been tried instead of loose fine grain gunpowder, with the idea of increasing the driving power of the charge and therefore the velocity of the bullets, or alternatively of reducing the necessary space for the driving charge, and so gaining space for more bullets. Compressed powder charges, however, entail a separate base and lead to complications and undue expense.

supports the weight of the bullets and prevents the bullets setting back on the shock of firing and crushing in the tin cup, and possibly exploding the gunpowder. In some cases the central tube is filled with gunpowder pellets, which by burning, increase the cone of dispersion of the bullets and give more smoke, which is exceedingly important for the observation of bursts in air. The interior of the shell is fitted with bullets set in resin, which, besides holding the bullets firmly, is ignited by the opening charge and so increases the smoke effect. The interiors of some shells are lined with brown paper in order to prevent the resin from adhering too firmly to the body of the shell.

The mouth of the shell is closed by a metal socket threaded for the reception of a fuze; the top end of the central tube is soldered to this fuze socket. When the gunpowder charge in the shell is exploded by a flash from the fuze down the central tube, the bullets are projected from the case to travel forward along the line of flight within a cone of small apex angle. The bodies of shrapnel are not intended to break up when the opening charge is exploded, but merely to act as containers to convey the bullets to the point of burst.

Another type of elongated shrapnel shell was formerly in use in which the burster was contained in the head. In this the head was firmly and the base very lightly attached to the body, so that on the explosion of the opening charge, the head and body remaining together were drawn over the bullets, and falling to the ground allowed the bullets to proceed on their course and scatter. In this pattern more bullets could be packed into a shell, owing to the elimination of the diaphragm and central tube; but instead of the closely grouped forward shower of bullets produced by the base burster, there was an open scattering of bullets, due to the checking, negative, effect of the opening charge on the bullets.

Normally field guns fire both high-explosive and shrapnel shell. Many attempts have been made to provide a "universal shell" which would combine the functions of both types. If the bullets of a shrapnel shell be packed in some high explosive instead of resin, then, on the time fuze igniting the base opening charge, the shell would open in the ordinary way, the high explosive (which as has already been shown is difficult to detonate) merely burning and giving useful smoke. But if a gaine, ignited only by the percussion portion of the fuze, be provided to act on some high explosive in the head of the fuze, then the whole of the high explosive, detonating on impact, would probably produce sufficient disruptive violence to shatter the whole of the shell and destroy material.

The Germans in the World War employed a type of universal shell having a high-explosive filling in the head, with the fuze so arranged that when the shell is required to burst in air, the head of the shell is blown off bodily, flies forward with the bullets, and itself bursts when striking the ground. If, on the other hand the whole shell is burst on impact, the disruptive effect of the high explosive in which the bullets are packed<sup>1</sup> breaks up the shell.

The Austrian universal shell is somewhat similar. These shell can be used in four ways, as a percussion H.E. without or with delay action, as a time shrapnel, and as a time H.E. The fuze is designed accordingly.

With the universal shell, there is a distinct loss of bullet capacity, with a consequent loss of shrapnel efficiency. It is therefore considered, in some services, more practical and effective to carry two types of shell, high-explosive and shrapnel, and use them according to tactical requirements, than to attempt the complications in design and manufacture, mistakes and possibly failures in the field, entailed by the use of a type of universal projectile.<sup>2</sup>

(c) *Armour-piercing projectiles* for maximum penetration, should be tempered so as to break rather than set up sensibly, and the stresses in the way of perforation and of fracture should be clearly distinguished. The main question is that of the striking energy modified by the projectile's power of holding together, which depends directly on the tenacity of the metal; and the capacity for taking a bursting charge would be of less importance than the strength of the head and walls. It appears probable, however, that the ultimate tenacity, as well as the limit of elasticity, would be the measure of the projectile's power. In direct impact, on deformation commencing, all penetration comes quickly to an end; but after commencing an injury, any

<sup>1</sup> This packing of the shrapnel bullets in H.E. is not an inseparable element of the design. In some universal shell, the ordinary resin or other non-explosive material is used. (C. F. A.)

<sup>2</sup> According to Schwartze (*Militärische Lehren des Grossen Krieges*) the German pattern of universal shell proved very disappointing in war, on the other hand the Austrian and other "Orisanz-Schrapnell" shell based on Ehrhardt design were most successful. (C. F. A.)

following up of the blow at the exact spot acts in so forcible a way that between the limit of elasticity and that of ultimate tenacity, a sensible amount of work must exist. Generally with projectiles for attack of soft armour, hardness is a necessity, and for attack of hard armour, tenacity is a necessity.

Armour-piercing projectiles may be divided into two classes. First come armour-piercing shell (fig. 7) in which the bursting charge is comparatively small, the head and point extremely hard, and the body softer to give greater tenacity. The success of the old Fallisier projectiles depended upon the metal used, the mode of casting, and the form of the projectile and distribution of the metal. With regard to these points specially selected iron was used; the projectiles were cast head down (to ensure density and soundness) in an iron chill with the result that the molten metal rapidly solidified and the qualities given to the head by white iron were intense hardness and crushing strength, but considerable brittleness; the form of the head was a fairly long elongated point, and the object in manufacture was to get the metal as far forward as possible so as to impress its momentum on the armour without acting through the medium of the walls of the shell, though the latter were necessarily thick; this method of manufacture obviously diminished the interior capacity and consequently the bursting charge of the shell.

As processes for hardening armour came to be introduced and used, the material for armour-piercing shell was necessarily changed to steel.

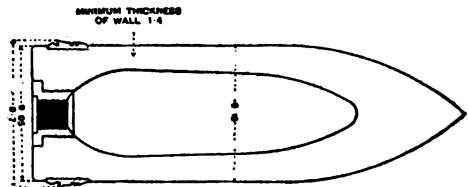

FIG. 7.

Owing to the liability to split spontaneously, due to the strains set up during the hardening process, the shell are stored for several months before being filled, and the bursting charge is contained in a thin aluminium container. The base is removable and a base adapter is fitted, the base being further secured by a copper gas-check plate, steel plate cover, and steel locking ring screwed to the adapter.

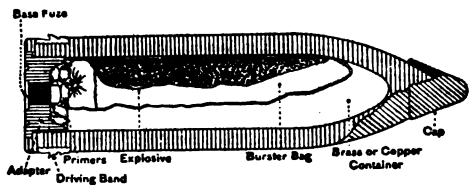

FIG. 8.

Secondly, there are semi-armour-piercing shell (fig. 8), which are practically common shell pointed, designed to effect a certain amount of penetration of light armour, and to contain a large bursting charge. The points are specially hardened, in some cases capped (as in fig. 9) and the bursting charge is held in a metal container.



FIG. 9.

Hard-faced armour defeats a projectile simply by fracture of the point and such fracture can in a great measure be prevented by a cap which protects the point when it meets the hard skin of the armour, whether the cap be hard and shattered or soft and crushed.

The first introduction of a cap was to allow a projectile to bite armour obliquely; but it is the value of a cap as a support to the point of the shell that has determined its use. Formerly the shapes of caps were designed without any consideration of the contour of



the shell; but in all recent types the cap is made to conform to the contour of the head of the shell. The use of the ogival radius determines the breadth across the front of the cap, while a certain thickness through the point is required to give satisfactory armour-piercing qualities, and the combined effect of these two dimensions prevents any appreciable reduction in the weight of the cap. The use of a cap introduces a serious disadvantage in that extra weight is put into the head, whereas the heavier part of a shell should be the base. The cap is attached to the head of the shell by notches in the shell or by interrupted ribs. The sheath of the cap may require to be built up from two or more pieces; and with heavy shell the cap may be in four pieces. (F. M. R.)

Fig. 10, showing typical outlines of German shell, taken from the *German Heavy-Artillery Ammunition Handbook* of 1917, may be of interest as illustrating the tendencies of design discussed above. Here (a) shows the old-fashioned 2 c.r.h. shell, with a front steady-

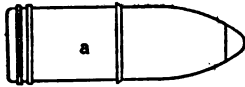

German 15 cm Howitzer H.E. Shell, 1914. Length about 3 calibres 2 c.r.h. Contoured Nose Fuse, Forward steady band & 2 Driving bands.

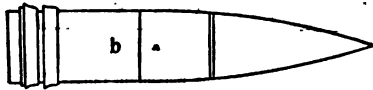

German 15 cm Howitzer Shrapnel 1916 Internal T & P Fuse, False Cap, 10 c.r.h. 8 Calibre long 2 Driving bands & decoupling ring.

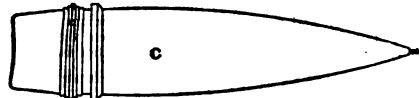

German 17 cm H.E. Shell, 4.7 Calibre long, streamlined with False Cap, Nose Fuse, 2 Driving bands & decoupling ring, about 11 c.r.h.

FIG. 10.

ing band of copper; (b) shows a false-cap shell without stream-lined base; (c) shows a stream-lined shell proper. (C. F. A.)

PROJECTILE FORM

The general form of the elongated projectile in use for many years prior to the World War is illustrated in fig. 1. The body

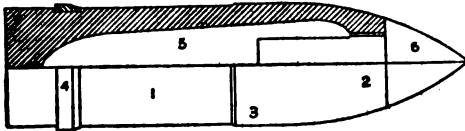

FIG. 1.

(1) is cylindrical in form and of uniform diameter except that the "bourrelet" or shoulder swell (3), intended to form a bearing on the lands of the gun, is slightly larger in diameter.<sup>1</sup> Special care is taken in accurately machining this bourrelet, and the average amount by which the diameter of the bourrelet is less than that of the gun is 1/1000 of the calibre.

It was the usual practice for many years to make the head (2) of ogival shape, with the centre of the circular arc in or near the plane of the front end of the body and with a radius of arc varying from 1 1/2 to 2 1/2 calibres. When a point fuze was used, as illustrated in fig. 1, its projecting end was sometimes; but not by any means always, made to conform to the shape of the head.

The rotating band (4) was placed at a distance of from 1/10 to 1 calibre from the base, and its width was 1/8 to 1/5 calibre. In addition to engaging the rifling in the gun and so causing the rotation of the projectile, other functions of the rotating band are to provide a rear bearing for the projectile, to provide a definite

In many shells this bourrelet does not appear, the walls remaining uniform from the driving band to the beginning of the head. In these cases a slight outward splay is given to the upper part. (C. F. A.)

seating for the projectile in loading, and to prevent the undue escape of powder gas around the projectile when the gun is fired.

In fig. 1, which illustrates a field projectile, the shell cavity is either cylindrical or larger in diameter toward the front end of the body, and the fuze is at the point.

In naval or coast-defence projectiles, where penetration of armour is desired, the general form is as illustrated in fig. 2.

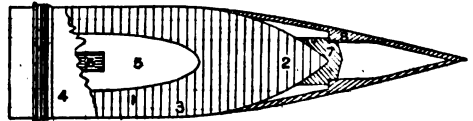

FIG. 2.

The great shock to which the projectile is subjected on impact with armour requires thickening of the walls at the forward end and shortening of the cavity. For the same reason the fuze can no longer be placed in the point but must be placed in the base. It is found that armour-piercing properties are improved by adding a soft metal cap (7) to the hard head (2). In order to get a smooth form of head, a hollow "false ogive" (8) was added to the forward end of the cap.

*Experiments to Improve Form.*—Previously to 1900, bullets for small arms had rounded points and "square" bases. Experiments started about that time in Russia indicated that a marked improvement could be obtained in flatness of trajectory, and this improvement opened the way for experiments in all countries to determine forms of artillery projectiles that would give increased ranges (or, for similar ranges, flatter angles of descent and higher terminal velocities). At that period (about 1907) the mounting of high-power ordnance, both field and naval, did not usually permit of elevations in excess of 20 degrees. There was a possibility of increasing ranges by modifying existing mounts or building new ones, but such a proceeding would have been expensive, and, as will be shown, might not in many cases have increased the range as much as the use of an improved projectile with the old elevation.

*Early Improvements in Head.*—Even before the adoption of sharp-pointed bullets in small arms, Petrovitch, a Russian, had about 1902 brought out a mathematical discussion of the form of surface which would encounter the least resistance in passing through an elastic medium. This paper helped to encourage experiments to improve the form of head. Firings were made in the United States in 1907 from a 6-in. gun with a 106-lb. projectile having a tangent ogive of 7 calibres radius, using a muzzle velocity of approximately 3,050 ft. per second. The outline of this projectile is shown in fig. 3.

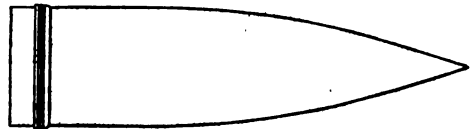

FIG. 3.

The range obtained was 12,800 yd. at an angle of elevation of 7°, as against 7,800 yd. obtained with the same weight of projectile with a 2-calibre radius and fitted with an armour-piercing cap as shown in fig. 2, without the false ogive. The muzzle velocity with the latter projectile was 2,990 ft. per second. This increase in range of 60% led to other experiments. As it was desired, however, to retain the armour-penetrating efficiency of these projectiles, attention was principally given to the design of a form of head and cap which would make the projectile efficient both for armour penetration and for range.

Firings were made with the same projectile having the point rounded off, as shown in the following table, which gives the corresponding range and coefficient of form:

Radius of Point In.	Range Yd.	Coefficient of Form
0.75	12,920	.505
1.25	11,940	.600
1.75	10,730	.762

It was supposed by some, at that time, that the air resistance was principally dependent upon the form of junction of head and body; that little additional resistance would arise if the sharp point was rounded off; and that the rounded form of point would add to the efficiency of the projectile in armour-piercing. The firings indicated a marked effect on range of even a slight rounding of the point. Armour-piercing projectiles of the form shown in fig. 3 did not seem

to stand up under the impact as well as those of the older form. But by the addition to the older (2 c.r.h.) projectile of a special cap and false ogive, it was found that not only could the excellent ballistic properties of the 7-calibre radius ogive be retained but, on account of the support given by the special cap, the armour-piercing ability of the projectile was increased. Similar experiments with 12-in. projectiles gave the following increases in ranges of the projectiles with 7-calibre ogives over those with 2-calibre ogives and blunt caps. The muzzle velocity was about 2,250 ft. per second.

Projectile	Ranges		
	1st series	2nd series	3rd series
Long Point	Yd. 5,365	Yd. 8,900	Yd. 13,800
Blunt Cap	5,020	8,000	11,900
Difference.	345	900	1,900
Percentage increase.	6.8	11.3	16.0

It is to be noticed that the advantage of the long sharp-pointed head increases with the range.

Similar tests made in France, England and Germany, with heads as long as 9-calibre radius ogive, left no doubt that a very substantial increase in range could be obtained by increasing the sharpness of the point through use of a longer head. As has been pointed out, the importance of this fact was not fully appreciated until the necessity arrived of obtaining extreme ranges from all guns. When full advantage had been taken of increasing muzzle velocities to the limit of the ability of the guns to withstand the necessary pressures, and means, sometimes improvised, had been used to permit the guns to be fired at the elevation corresponding to the maximum range, there remained only improvement in the projectile to further increase the range.

**False Ogives.**—The hollow extension of the head covering the fuzee of field projectiles or the armour-piercing cap of armour-piercing projectiles is called a false ogive.<sup>1</sup> Its use was first suggested in America in 1907 by Capt. W. A. Phillips as an extension for the blunt cap of armour-piercing projectiles. Apart from its effect in lengthening and sharpening the head, and thus increasing the range, no ballistic advantage was claimed for it. Its use with an A.P. projectile is shown in fig. 2. As applied to field shell the false ogive covers the end of the fuzee. It is desirable to make the cavity of the shell as large as possible, and so the walls of the shell proper are run forward as far as they can be, and still permit a tap for the fuzee of proper size at the front. The head is then completed by screwing the false ogive over the fuzee (see fig. 4).



FIG. 4.

The use of a light false ogive throws the centre of gravity backward with respect to the centre of form. This is found to be of advantage in point of ranging power, providing the somewhat greater tendency to initial yaw is sufficiently counterbalanced by increased spin.

**Improvements in Form of Base.**—Experiments to determine the best form of base commenced soon after these remarkable improvements in range by changes in the head were obtained. In experiments made in 1913 with a 6-pr. gun use was made of ogival and tapered bases coming to a point, the total length of base from the start of the taper being 1 calibre or less.

The resulting ranges were generally less than those of the square-based projectile of otherwise similar form and weight, and they were less accurate. Bases of 1-calibre length tapered to a cone of 9° were then tried, but seemed to give no better results than the square base. In both these experiments the projectiles had ogival heads of 2-calibre radius. Experiments made in 1915 with 6-in. projectiles of the three forms of base shown in fig. 5, fired with a muzzle velocity of 2,675 ft. per second, at an angle of elevation of 5°, gave the following results:—

Form of Base	Mean Range	Mean Dispersion	
		Range	Deflection
A	Yd. 8,200	88	9
B	8,440	41	7
C	8,410	52	6

A small increase in range and greater accuracy is shown by the boat-tailed projectiles.

French experiments made in 1914 demonstrated that the form of base to give the best result with any projectile is dependent upon the form of head used, and vice versa. A similar conclusion had been reached elsewhere.

<sup>1</sup> Known also as the ballistic cap or "false cap."

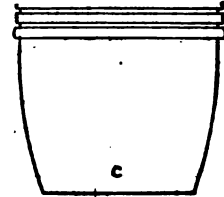
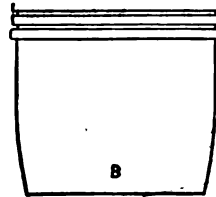
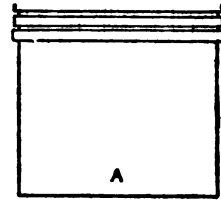

FIG. 5.

**Influence of Velocity.**—By comparing maximum ranges obtained with various projectiles and velocities with ranges *in vacuo*, we may obtain a good idea of possible improvements in projectiles.

Fig. 6 shows vacuum range as a function of velocity plotted to a logarithmic scale, together with other lines showing fractional parts of the vacuum range and points showing the maximum ranges of actual guns. The ranges of low-velocity guns fall near the vacuum line, while those of high-velocity guns are much farther away.<sup>2</sup>

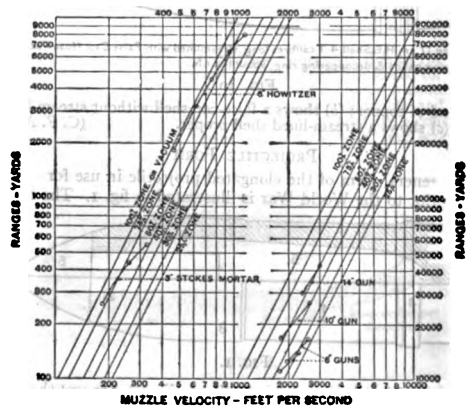

FIG. 6.

The possible improvement in projectiles to be fired from low-velocity guns is, therefore, very much less than in those fired from high-velocity guns. Actual trials show that within reasonable limits neither the form of the head nor that of the base has an important influence on maximum range or accuracy when the velocity is less than 1,200 ft. per second.

**Improvements in Rotating Bands.**—Although the rotating band has performed all its useful functions by the time the projectile has left the gun, it still has to be reckoned with, since it is capable, if improperly designed or located, of materially reducing the range and increasing the dispersion. If it has a "lip" (called in Great Britain "gas check") or is thick at the rear, the excess metal will be wiped back on the passage of the projectile through the bore and will form a ragged extension; and when the projectile is free the centrifugal force due to its rotation may be enough to cause this extension to

<sup>2</sup> Explanation of fig. 6.—Abscissae show velocities in f/s, ordinates ranges in yd., oblique lines the % of theoretical vacuum range obtained in practice. Thus the 10-in. gun, which obtains a range of 26,500 yd. with a m.v. of 2,600 f/s in actual practice, would obtain with the same velocity one of 63,000 *in vacuo*. 26,500 is 42% of 63,000 and the projectile is therefore spotted between the 40% and the 50% lines.

stand out perpendicularly to the projectile and thus immensely increase the air resistance. Conditions are not improved by the partial breaking-off of this extension or by its incomplete formation in the gun. It is just this irregular form and size of this extension or "fringing" of the rotating band which makes it a possible source of great inaccuracy. Whether fringing actually takes place depends not only on the design of the band but also on the velocity of rotation of the projectile and the thinness and length of the extension formed at the rear of the band. By taking all these points into consideration it is possible to make a design which will give no trouble from fringing. But, apart from the effect of fringing, the rotating band may materially increase the resistance if improperly located. While it is desirable from other considerations to have the rotating band as near to the base of the projectile as possible, it is found that a better position for range and accuracy, even if a square-based projectile is used, is  $\frac{1}{2}$  calibre or more from the base. Similarly, if a boat-tailed base is used, the range and accuracy are both reduced if the band is placed just at the beginning of the taper. It should be at least  $\frac{1}{8}$  calibre forward of this position.

Double and even triple rotating bands close together at the rear are sometimes used, the idea being that this construction will make the band more efficient as a gas check and that fringing is less marked than for a single rotating of the necessary width. Bands near the bourrelet have also been used. A more recent development is the use of a copper bearing band at the bourrelet.

**Optimum Weight of Projectile.**—The question of the weight of projectile to be used with a gun of a given calibre frequently arises. Other considerations besides that of ballistics affect the answer. There is a practicable limit to the pitch of rifling, which has been fixed at about one turn in 15 calibres for low-powered guns, and one turn in 20 calibres for higher-powered guns. With some such limit in pitch of rifling, projectiles cannot be made more than about 5 calibres in total length and retain the necessary factor of stability in flight. There is thus formed a certain upper limit of length and weight. If the projectile is shortened below this limit and the weight reduced, we may assume that, with the use of a suitably quicker powder, the same muzzle energy and consequently a higher muzzle velocity may be obtained; but while the higher muzzle velocity would tend to increase the range, the smaller weight and ballistic coefficient would tend to reduce it. It is evident that for each gun there is some weight of the projectile, called the "optimum" weight, which will give the greatest range, assuming the muzzle energy constant.

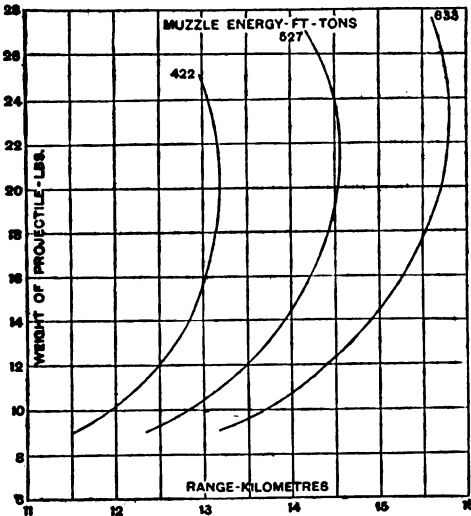

FIG. 7.

The weights of similar projectiles vary with the cube of the calibre. Similar projectiles for different calibres, being the same length in calibres, are of equal stability providing the pitch of rifling is the same. The weights of the optimum projectiles vary about with the square of the calibre, if based on uniform muzzle velocities in different calibres. For high-powered guns of calibres roughly below 5 in. the optimum weight is greater than the usually accepted weight based on similarity, and for larger calibres it is less. The optimum weight of projectile for any gun and muzzle velocity may be readily worked out by the methods of exterior ballistics, by assuming several different weights of projectiles and

working out the maximum ranges on the basis of equal muzzle energies. Fig. 7 illustrates the maximum ranges to be expected from a 75-mm. gun under the assumption of equal muzzle energies. It is to be noted that the optimum weight increases with the muzzle energy and that the range changes only slowly as we pass from the optimum weight. In the case of large-calibre naval or coast-defence guns a reduction in weight of projectile tends toward optimum, that is, toward increase in range; but the reduced weight and increased velocity of the projectile lead to greater losses of energy in flight, resulting in a smaller striking energy at a given range. (W. H. T.)

**MANUFACTURE OF SHELL**

The material of which a projectile may be made depends largely on the functions required of it.

Cast iron is brittle, more or less hard, with low elasticity, practically no ductility, and low tenacity; consequently this material is of no value for a shell which is required to do heavy work at the end of its flight or to promote a good explosive effect, and is somewhat risky when required to stand the shock of discharge from a high-velocity gun. Cast iron, however, is fusible and easily worked, and therefore cheap; it is consequently sometimes used for practice shot with reduced propellant charges. In the World War it was used for certain chemical shell where the chemical content was liable to attack steel, and—especially by the Germans—as a substitute for steel when the latter could not be had in sufficient quantities; but its use for projectiles is almost entirely confined to such. Wrought iron has a fair tenacity and a good ductility, but it is quite superseded by steel which can be manufactured as easily and cheaply.

Steel possesses the characteristics of elasticity, ductility and tenacity, and is sufficiently hard to enable it to withstand the stresses and shocks a modern projectile is required to sustain. Forged steel<sup>1</sup> is fibrous in molecular structure, and is improved by forging, which increases the tensile strength and minimizes the chance of porous metal remaining; the more work put into the forging, the better the quality of the finished material as measured by its tensile strength in the direction of the forging. Cast steel is crystalline in molecular structure and much harder than forged steel and has less ductility and tenacity; it must always be annealed after it has been allowed to cool after casting, in order to dissipate the uneven molecular stresses set up during cooling. In the case of steel for projectiles the composition includes from 0.35% to 0.7% of carbon and small percentages of nickel, manganese, and silicon. With cast steel, the walls of a shell cannot be so thin as with forged steel because the material is not so good and there always is a risk of blow-holes and porous metal being present.

The chemical composition of the steel for shells is generally as follows:—

	Composition: Per cent		
	H.E. Shell	Shrapnel	Armour-piercing Shell (†)
Carbon . . .	0.5	0.75	0.5 to 0.75
Silicon . . .	0.35	0.3	0.5
Manganese . .	0.4 to 1.0	1.0	1.25
Sulphur* . . .	0.08	0.04	0.08
Phosphorus* .	0.08	0.06	0.06
Tensile strength.	35-49 tons/in. <sup>2</sup>	{ (Light shr.) 56 tons/in. <sup>2</sup> (Heavy do.) 38 tons/in. <sup>2</sup>	38 tons/in. <sup>2</sup>
Yield point .	19 tons	{ (Light shr.) 36 tons (Heavy do.) 24 tons	24 tons

\* The sulphur and phosphorus are deleterious and should be as low as possible.

† Steel for A.P. shell should have a higher percentage of carbon in order to give harder material.

<sup>1</sup> The term "forged steel" is still used but the process of forging under a hammer has been discontinued for some time, the hydraulic press being used instead. The hydraulic press is said to work the mass more uniformly than does the hammer, while hollow-forging on a mandril has the same advantage over solid-forging. Forging should cease at a temperature of about 1,200° F., for if continued below this temperature, the metal tends to become "hammer hard" and internal strains are introduced.

H.E. shell are always made of forged steel; they have coned walls, thicker at the base to give better strength to the shell. The body requires to be as strong as possible so as not to break up too readily and thus lose the value of the pressure set up on detonation; also, unless the best steel is used the body is pulverized instead of breaking up into pieces of a size to form effective missiles. Pointed shell, whose general use is for the attack of armour plate, require to be especially tough and strong.

Common shell have been made of cast iron, cast steel, and forged steel; a disadvantage with forged steel is that, with a bursting charge of gunpowder, the shell breaks up into a small number of fragments; the stronger the material, the thinner can the walls be made, and hence the larger the bursting charge.

Shrapnel shell are generally made of forged steel, though in some larger natures they have been made of cast iron. The steel is required to have a high yield point and breaking stress, as this is essential in order that the body, which is made as thin as possible to provide a maximum capacity for the bullets and opening charge, may be able to withstand the pressures set up on the shock of discharge from the gun.

A.P. shell are made of either cast steel or forged steel; the points are made extremely hard, and the bodies softer; great thickness of metal is worked into the head, and the walls are made thicker than in other shell.

The steel for projectiles is made by different methods: (1.) *Crucible*, which is largely used on the continent of Europe, particularly in Germany. With this method there is difficulty in obtaining uniform quality. (2.) *Bessemer*, which does not lend itself to the careful control necessary for production of the steel suitable, though the method is rapid and cheap. (3.) *Open hearth*. The acid process is preferred to the basic as more suited for production of steel of uniform quality, and more economical. As it does not remove the phosphorus, a purer pig-iron must be used.

The manufacture of H.E. shell (other than solid-pointed) is carried out in a hydraulic press. The cast-steel ingot is heated up and punched, care being taken to ensure a central cavity in the forging; for larger shell several punches or drawings, with intermediate heatings, may be necessary to produce the required dimensions. The forging is then oil-hardened by heating up to a specified temperature and quenching in oil. Analytical and mechanical tests are next applied to samples and, if satisfactory, the forgings are sent to the machine shop for machining and centring. The shell are then heated to a dull red heat for the purpose of "heading" or "bottling" to give the required ogive to the head; this is carried out by forcing the head of the shell into a die by hydraulic pressure, and can be done cold, but cracks are liable to occur at the shoulders on account of the internal stresses. For "bottling" larger shell, it is sometimes necessary to taper the walls of the shell previous to carrying out this operation. The head is then bored and screw-threaded to receive the fuze hole bush, and the exact ogive given in a "radius" machine, which is similar to an ordinary lathe, except that the tool-carrier is designed so as to allow the tool to act on the head of the shell at a variable distance. The base is then faced and turned down to the required thickness. There are also other machining operations necessary, such as recessing the base to permit of the detection of any tendency to weakness at the centre, after which examination a steel disc is inserted in the centre of the base and either screwed in or secured by burring some of the metal of the shell over it by means of a pneumatic hammer. The interior of the shell is sand-blasted, coated with copal varnish, and stoved for six hours. This process gives a very smooth internal surface and it prevents premature explosion from friction, in case of any movement of the explosive arising from bad filling; it also prevents chemical action of the filling on the metal of the shell.

The groove for the driving band is machined, the sides of the groove being slightly undercut to assist in holding the band in place; the bottom of the groove has three or four waved ribs cut along it to prevent the band from rotating in the groove, and two or three chisel-cuts are made across the ribs to permit of the escape of any air while the band is being pressed into position.

The driving bands themselves are made from discs of copper as free from impurities as possible, the best kind being that which has been electrolytically deposited. The discs are formed into cups and are then annealed and drawn alternately until drawn into a long tube, five draws being the usual number. The copper tube is then parted into rings, which are given a final annealing. For banding, the shell are placed in a machine which consists in a circular

holder, of which the periphery is divided into segments to which hydraulic presses are attached; a copper band is placed over the shell opposite the groove, and pressure is applied till the band is firmly wedged into the groove. The driving band is then turned to the required shape and dimensions.

*Shrapnel shell* are manufactured in two designs, those for larger guns having a separate head while for smaller types the head and body are in one. Except that the operation of "bottling" or "heading" can be dispensed with for the larger sizes, the method of making the body is very similar to that for H.E. shell, but from the nature of the design of shrapnel, the body requires some internal machining in addition.

The heads of the larger shrapnel are made of soft steel or malleable iron, prepared to take the fuze-hole bush (the remaining space being filled by a block of wood), and secured to the body by pins and rivets and soldering firmly enough to ensure that the whole shell rotates in flight as a single body.

The cups for the opening charge are made from tin-plate, and the steel diaphragms from discs sheared from a billet of steel, stamped into shape, and then brought to the required dimensions by grinding; a hole is bored in the centre and screw-threaded to receive the central tube, which is made from a butt-ended tube, and is turned and screw-threaded at its lower end to fit the central orifice of the diaphragm. The socket to receive the fuze is a brass stamping, screw-threaded internally to take the fuze and externally to screw into the body of the shell.

*Pointed shell* may be of three types, which are in Great Britain designated—common pointed, common pointed capped, and armour-piercing. The operations in manufacture are very similar in each case. For A.P. shell, more work is put into the steel in order to make it as strong as possible and for this reason those shell are usually forged. The common-pointed and common-pointed-capped shell are punched and drawn in the usual manner. The shell then undergo a heat treatment in order to remove any strains which may have been set up, the temperature of the furnace being raised to about 1,100° F. After treatment the usual machining operations are carried out, and the shell are then heated up again and hardened by being quenched in an oil bath. Since it is required to retain only the head in a hardened condition,<sup>1</sup> the remaining part of the body is then "let down" by being immersed in a heated bath of lead to a short distance below the shoulder; this process removes the hardening effect and leaves the body tough instead of brittle.

The hardening of the head is liable to cause the occurrence of spontaneous splits; and shell are therefore stored in the open for a period so as to allow time for any splits to develop before filling. Should a split extend to the cavity of the shell when filled, the sudden fracture might cause the explosion of the bursting charge; consequently the shell are fitted with aluminium containers which, as thin cones, are inserted into the shell and spun into position.

The interior of the body is then bored to its final dimensions and the lower end of the cavity screw-threaded to receive the adapter which carries the base fuze. The shell are then banded and the interiors varnished.

Adapters (which vary in size from a mere fuze-hole lining to what is almost a base in itself) are cut from the billet and screw-threaded externally to fit the shell and internally to take the fuze. In some cases a further organization of the adapter base is required to prevent a possible inrush of propellant gas round an ill-fitting fuze into the interior of the shell; this consists of a copper gas-check plate over the fuze, held inside a steel cover which is bound to the adapter base by a locking ring. In such designs the adapter base flange is prepared accordingly during manufacture (fig. 1).

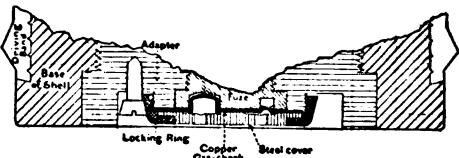

FIG. 1.

When caps are fitted, the usual method is to make peripheral notches in the head of the shell before hardening; the cap is soldered to the shell and retained in position by indenting the lower edge into these notches. Other methods of securing the cap are also in use.

*Shell Manufacture in War Emergencies.*—In the adaptation of the engineering industry to the manufacture of shell, the capability and capacity of the plant installed in any one workshop is the ruling factor governing the work to be allotted to that shop. The design of the shell must of course be simplified as much as possible to suit the existing machines. The very rapid output requisite and resulting from any such adaptation necessitates that the various stages

<sup>1</sup> As the base is the heaviest part of the shell, it is in this operation that the various shell are brought (as nearly as possible) to uniform weight.

<sup>2</sup> These diaphragms can also be made from drop-forgings.

<sup>3</sup> In the case of common pointed, the head is not hardened.

In the process of manufacture must be semi-automatic at least and, consequently, the organization of the shop and the machines having been adjusted with that object, the labour employed must be arranged for purely repetition work, for which it can be trained easily and quickly.

Having regard to this, and to the capacity of an ordinary engineering shop, it is essential to allocate only a certain number of stages in any one process to any one workshop, suitably arranging the stages to the power of that shop.

The machines mostly to be found in an engineering shop can generally be adapted for any of the operations required in the machining of shell. The ordinary engine lathe can be easily converted for the boring and machining of larger shell, and drilling machines and turret lathes for the same operations with smaller shell. The main point to be considered is the provision of suitable jigs and gauges to enable every operation to be performed by semi-skilled labour in rapid repetition. For hydraulic-press forging of bodies of shell and for the pressing on of driving bands, however, the machines necessary are not usually to be found in the ordinary engineering shop; and as it is not easy to find substitutes on account of the high pressure requisite in working, and the manner in which it is necessary to apply that pressure, arrangements for these operations have to be made specially. But with a certain few specially arranged shops of such nature, a supply of part-wrought material could be easily put out sufficient to keep fully employed a relatively large number of ordinary engineering shops adapted for the machining operations.

(F. M. R.)

CARTRIDGES AND PRIMERS FOR ORDNANCE

Cartridges for ordnance may be divided into two main classes—technically called "breech-loading" and "quick-firing"—and each class subdivided into gun and howitzer cartridges. All guns are nowadays breech-loaders, and the main classes mentioned above are termed B.L. or Q.F. in reference to the system of "obturation" (breech-sealing) employed with the gun. With the B.L. obturation is effected by the breech mechanism, while with the Q.F. it is effected by the cartridge case.

The envelope of cartridges for B.L. guns must be of a material which will stand wear and tear when filled, not deteriorate from chemical action of the explosive while in store, not have injurious effects on the explosive, and be entirely consumed in the gun when the charge is fired, leaving no débris smouldering in the gun after the charge has been fired. Silk cloth made from the refuse silk from the outside of cocoons has been found to be the best material for the purpose.

The propellant explosive, according to the nature of the gun, is either cordite, N.C.T. (nitrocellulose tubular), or ballistite.

All smokeless powders are somewhat difficult to ignite in a gun. Therefore, to make ignition certain and to prevent hang fires an igniter of fine grain gunpowder is used with every cartridge. This powder is enclosed in a bag of shalloon, which is attached to the cartridge in such a position as to intercept the flash from the tube.

Prior to the use of any batch of propellant for cartridges, it is necessary to prove the propellant, as received from manufacture, in order to ascertain whether it conforms to specification requirements. In a chemical test a small amount is subjected to certain analytical tests. In a ballistic test a certain number of charges, made up according to the intended design of cartridge, is fired in a comparative trial against a like number of similar charges of a batch of propellant known as a "current standard." Current standards are compared in a similar manner with a "master standard," the ballistics of which have been ascertained under certain specific conditions. By this comparison, both in the velocities given to the projectile and in the pressures given in the gun, the variation from the standard is found for the batch, and any adjustment in the weight of the charge necessary for the intended cartridge can be determined.

B.L. cordite cartridges are built up of bundles of cordite in the form of sticks cut to the required lengths, and the bundles are tightly tied with silk and inserted into silk cloth bags, of which the ends are closed by discs of similar cloth. An igniter is stitched on to one or both ends of the cartridge. The exterior is laced with silk cloth tape so as to form a stiff cartridge. The charges for heavy guns are made up in separate portions containing half and quarter charges for convenience of handling and to allow of a reduced charge being used. For some of the longer guns the exterior of the cartridge is made cone-shaped, the coned form being produced by building up layers round a cylindrical core. In large cartridges a silk cloth becket runs up the centre and has a loop at the top for handling.

N.C.T. and ballistite have been used only for cartridges for smaller natures of guns. The method of making-up need not be described here; but it may be pointed out that, not being like cord-

ite, in the form of sticks, they do not make up into such compact cartridges, and that ballistite does not need an igniter.

For howitzers, variable charges are required, and cartridges must be built so that charges can be readily altered. Moreover, since a howitzer is shorter than a gun of the same calibre a lighter charge of cordite of smaller size is required, to ensure the charge being usefully consumed before the projectile leaves the barrel. The cartridge is formed of a mushroom-shaped core made up in a bag to which the igniter is attached. On the stalk, so as to be easily removable, are placed the remaining portions of the cartridge made up in the form of rings, attached to the stalk by silk braids or light sewing. The weight of cordite in the rings is so graduated that by detaching one or more, the varying charges required can be obtained.

With Q.F. cartridges the charges are contained in brass cases. This class of ammunition is of two types: (i.) "fixed ammunition"—in which the projectile is fitted into the mouth of the brass case, thus closing it; (ii.) "separate ammunition"—in which the projectile is separate from the cartridge. The brass case itself effects obturation in the gun, for, when the cartridge is fired, the case expands slightly and tightly fits the chamber of the gun, thus preventing any escape of gas through the breech.

The use of the brass case influences rapidity of fire in that it obviates the necessity for sponging out the gun after each round to remove smouldering débris; it allows of the cartridge carrying its own means of ignition, so avoiding the separate operation required with B.L. cartridges. The brass case also offers the advantage of greater safety against the risks of catching fire, and double loading of a gun is an impossibility.

This class of cartridge is especially useful for smaller natures of guns; but with larger natures of guns the rate of fire is nowadays not appreciably affected.

On the other hand the expense of the brass case is a serious consideration; and should a case, by reason of a flaw or split, fail to effect obturation, serious damage may be caused to the gun. Further, in emergencies, failure in the supply of brass might seriously hamper output. The brass case causes a large increase in weight to the cartridge, and so entails increase in means of transport. And as, to save material and expense, fired cases are collected, repaired and used several times over, considerable labour is involved in the salvage and transport.

The use of Q.F. ammunition has been restricted in the British service principally to smaller natures of guns; but the Germans have employed metallic cartridge cases for the largest natures of guns, probably on account of the difficulty in ensuring trustworthy obturation by any other means practicable with sliding-wedge breech mechanisms, and also in the naval service owing to their giving greater safety from premature ignition.

The manufacture of the brass case is a lengthy process and requires care to ensure satisfactory results. The case is made from a disc of suitable thickness, which, being pressed through dies by hydraulic power, is shaped first into a cup and then gradually into a solid-ended cylinder. In order to relieve the stresses set, up the case is annealed between each draw. The head of the case is machined round the solid end to form a rim, by means of which extraction by the breech mechanism of the gun is effected. And, after having been passed through a die to give the taper required to allow of easy loading, the case is subjected to the final operation of machining to specified dimensions and to prepare the central hole in the head for reception of the means of ignition.

Charges for Q.F. cartridges are made up similarly to those for B.L. cartridges. Where necessary distance pieces of papier mâché tube and felt wads are used to fill up the space in the case, and so prevent any movement of the charge. The lower end of the charge is played out to fit round the hole for the means of ignition, and in cases where this is a cap a small igniter of powder enclosed in a shalloon bag is placed next the flash hole of the cap in order to increase its effect.

With fixed ammunition the mouth of the brass case is closed by the projectile, which is covered on the outside, below the driving band, with a cement to give a water-tight joint, and retained in position either by the lip of the case being pressed over a slightly coned portion prepared on the projectile, or by indentations in the lip of the case being pressed into a groove on the periphery of the projectile. With separate ammunition a cardboard disc and felt pad are inserted above the charge, and then a lid of white metal retained in position by small tongues turned down from the lip of the case.

For cartridges for Q.F. howitzers the charge is made up similarly, but as the charges must be easily adjustable separate ammunition must always be used, and the cartridge arranged so that the lid of the case may be easily removable. The mouth of the case is closed by a removable cup-shaped cardboard disc, and sometimes, as a greater protection against moisture, by an india-rubber cap which fits tightly round the mouth of the case (see fig. 1).

In order to reduce the flash on discharge of a gun anti-flash charges have been under experiment. A small charge of ammonium

<sup>1</sup> Towards the end of the World War steel cartridge cases were employed by the Germans as a substitute for brass, but only for rifles and to some extent for light machine-guns. (C. F. A.)

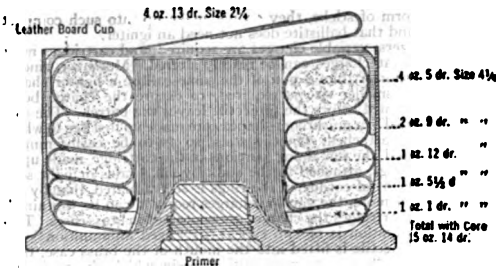

FIG. 1.—4-5 in. Q. F. Howitzer Cartridge.

oxalate and mealed powder enclosed in a shalloon bag and placed between the projectile and the cartridge was tried during the war. The addition of mineral salts such as sodium or potassium chloride has also been tried; but so far the results have not been very satisfactory.

**Means of Ignition.**—Amongst the various methods that have been evolved for the firing of the gun only the friction tube, the percussion cap, and the electric bridge are now in general use, and of these the friction tube is practically confined to old models of guns continued in the service of various countries owing to the need of all available material in the early and middle stages of the World War.

With the percussion tube ignition of the powder in the body of the tube is obtained from a blow on the head of the "striker," which drives a percussion cap against a hollow brass anvil. The cap consists of a copper shell, cup shaped, coated on the interior with fine varnish; this shell is filled with a chlorate mixture, a thin tin-foil disc is pressed in, and a coating of varnish applied in order to prevent excess of moisture. Internal sealing is obtained by the shell of the cap being expanded into its seating by the force of the explosion.

There are two types of electric tube, one with external wires for joining up with the electric circuit and the other without external wires. In the former two insulated wires are led into the interior, and in each circuit with these there is a wire "bridge" of platinum silver surrounded by a priming composition of gun-cotton dust and mealed powder. On an electric current passing, the bridge is heated to incandescence and ignites the priming composition. In the second type (see fig. 2) the breech mechanism of the gun makes electric contact with an insulated disc in the head of the tube; this disc is connected by an insulated wire to an insulated brass cone, the bridge being formed from the edge of the cone to a brass wire soldered to the mouth of the tube; priming composition surrounds the bridge. The electric current passes from the breech mechanism to the disc in the head of the tube, thence through the bridge to the body of the tube and through the metal of the gun. Internal sealing is obtained by the cones being driven backwards into conical seatings.

#### BRASS FULL SIZE

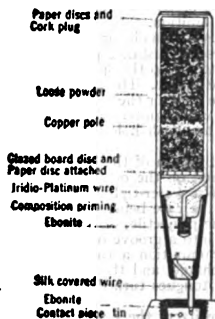

FIG. 2.—Tube, Vent Sealing, Electric W. P.

In Great Britain the term "tube" is officially used to designate the smaller firing devices of this class which are pushed into position, and "primer" for the larger ones which are solidly screwed into the base of Q. F. cartridge cases. In the United States the term "primer" is common to both. (C. F. A.)

In some instances during the war period firing was done by means of a cut-down service rifle screwed into the breach of a gun; in this case an ordinary blank rifle cartridge acted as a percussion tube. (C. F. A.)

With Q. F. cartridges the means of ignition are carried in the base of the brass case, and may be either (a) a percussion cap, (b) a percussion or an electric primer, (c) a percussion or an electric tube held in an adapter. The percussion cap is precisely similar in principle to that of a rifle cartridge and needs no description. The primer is used with larger guns and affords easily replaceable means of ignition. In both percussion and electric types the body of the primer is made of an alloy resembling brass; externally it is screw-threaded to screw into the recess prepared in the base of the cartridge case, internally it is recessed to form a magazine. The percussion primer is fitted with a percussion cap resting on an anvil pierced with flash holes; the anvil is recessed to hold a copper ball and retained by a screwed plug also pierced with flash holes. The action is the same as with a percussion tube; internal sealing is obtained by the copper ball being driven backwards in the coned recess in the anvil. The electric primer is similar to the vent-sealing electric tube in construction and action.

The primer is being superseded by a vent-sealing tube held in an adapter externally of the shape of the primer. The adapter is bored internally to receive the vent-sealing tube, percussion or electric, which is retained in position by a small stud operated by a spring. Attached to the front of the adapter is a metal container filled with a small charge of gunpowder to augment the flash from the tube. (F. M. R.)

#### FUZES

A fuze is the device or mechanism that ignites the bursting charge of a shell fired from a gun, howitzer or mortar. Fuzes fall into two categories, those which burst or open the projectile in flight (*time fuzes*), and those which burst it on impact or graze (*percussion fuzes*). Of the former all, with the exception of the recently introduced clockwork fuzes, rely for their action on the known speed of burning of a readily ignited composition. In the days of muzzle-loading guns the flash of the powder charge ignited this composition, but in the modern breech-loading guns the passage of the burning gases is checked by the driving band of the projectile, and other means have to be employed for its ignition.

The percussion fuzes in nearly all cases rely for their action on a movable pellet in the interior which—held in position by a shearing wire, centrifugal bolts, the direct pressure of the powder gases (as in some base fuzes) or other means—is released by the shock of discharge and is free to move. The fuze is then described as "armed."<sup>2</sup> The pellet is provided with a disc of detonating composition at the end which is foremost when the shell is in the gun and on graze or impact the pellet flies forward, and the patch of detonating composition impinges on a sharp point or "needle" in the front end of the fuze, the flash igniting a charge of gunpowder or other explosive in the "magazine" and this in turn igniting the bursting or opening charge of the shell.

In the large proportion of time fuzes the same principle, *i.e.* the movable pellet and detonating patch, is relied on for the ignition of the ring or rings of composition. A precaution is necessary, however, with regard to these pellets when free to move in the interior of the fuze, as it has been found that they, not being exposed to air resistance, have a tendency to move forward as the shell loses velocity, and thus to cause premature bursts in flight. To counteract this tendency weak spiral or "creep"-springs are so fitted as to control the forward movement of the pellet. There are other additional devices to secure the proper arming and subsequent action of the fuze which will be described in due course.

All fuzes are screwed into a bush or adapter either in the head of the shell (*nose fuzes*) or, in case of solid-pointed shell, into the base (*base fuzes*). With certain "false-cap" shell the fuze is internal, that is, inside the false caps, but it is in effect a nose fuze in that it is placed in the front of the explosive container.

**Percussion Fuzes.**—Among percussion fuzes the simplest are those known as direct action, and a British example known as Fuze No. 44 is shown in fig. 1. This fuze is provided with a safety shutter—a device to which reference will frequently be made in the sequel—and for safety in transport is fitted with a cap and a safety-pin which blocks the moving parts. On loading, the cap and safety-pin

<sup>2</sup> All fuzes before acceptance as service stores are subjected to rough-usage trials to test their powers of resistance to shocks during transport, and it will be understood that the process of "arming" is necessary both to secure this and to prevent premature action in the gun.

attached to it are withdrawn and the head of the fuze exposed. In this is a needle supported by a copper disc over a detonator. Under this a pivoted shutter, kept in position by a spring, closes a channel leading down to the magazine, which is filled with a detonating composition known as "C.E." On firing, the shock of discharge does not

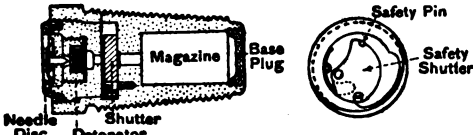

FIG. 1.

affect the relation of the parts but, after a certain small interval of time, the rotation of the shell causes the shutter to swing outwards round its pivot, overcoming its spring and uncovering the fire channel. On impact the needle is crushed down on the detonator, the flash from which, travelling down the now open channel, fires the magazine and explodes the shell.

Fuze No. 134 (fig. 2) exhibits some interesting characteristics. It is a "delay-action" fuze, i.e. it is so arranged as to burst its shell about 0.20 of a second after impact. The pellet of this fuze is provided with three inclined projections. The construction of this pellet, of which the upper part is bored out for the reception of the detonator and the lower portion serves as a support for the guard spring, will be best understood from the figure which also shows the position of this pellet before firing and when "armed" after firing.

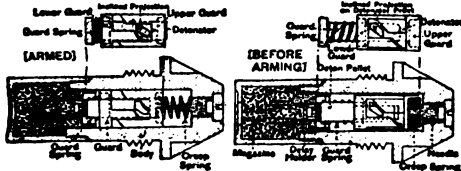

FIG. 2.

The action is as follows: Before firing, "ramps" or inclined surfaces formed on the upper guard bear against the upper portions of the inclined projections on the detonator pellet, and are held there by the creep-spring, while the base of the lower guard is pressed upwards against the bottom of these projections by the guard-spring. The two guards and the projections being thus locked by the friction of their surfaces, the guards completely mask the detonator. On the shock of discharge the lower guard sets back, compressing the guard-spring. The "ramps" on it ride down the inclined projections on the pellet, giving the guard a slight movement of rotation. The upper guard, impelled by the creep-spring, is then free to follow the lower, and the detonator is unmasked. The guard-spring then reasserts itself, and its upward pressure jams the guards in the set-back position. On impact the pellet moves forward, overcoming the creep-spring and carrying the detonator on to the needle. The flash from the detonator ignites some mealed powder in the interior of the pellet which communicates with the delay composition, this in turn, after the momentary delay desired, igniting the magazine.

Fuze No. 18 is a simple fuze, the action of which will be understood from fig. 3. It is protected by a strong cap which is removed at the

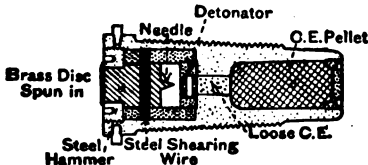

FIG. 3.

last moment before loading. The fuze is quiescent in all its parts until direct impact takes place, when the steel hammer is crushed in and, breaking the steel shearing wire, carries its needle-point on to the detonator. The explosion of the detonator fires the loose exploding composition (loose C.E.) in the central channel, which in turn fires the magazine of the fuze (C.E. pellet) and the bursting charge of the shell.

A variation of No. 18, known as No. 45, has a pivoted safety shutter which is similar to that of No. 44, except that when it rotates, instead of merely opening communication between the detonator and the magazine, it brings a patch of composition of its own under the detonator to reinforce the downward flash.

In Fuze, Percussion, No. 106, which is of the instantaneous class, the principal feature is that it is armed by the unwrapping of a steel tape with a weighted end. The general construction will be understood from fig. 4 which shows the fuze uncapped and ready for firing. A split steel collar is interposed between the under side of the ham-

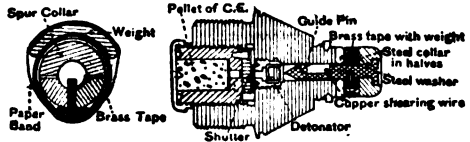

FIG. 4.

mer-head and the top face of the fuze body, and it is round this collar that the tape is wound. On firing, the weight at the end of the tape is gripped by the set-back of the hammer, which receives additional support from the steel split collar. When acceleration ceases—that is, when the shell leaves the bore—the weight is released, flies off, unwinding, and carrying the tape with it. The segments of the split collar are torn away by the end of the tape, and the hammer is then supported only by a thin shearing wire. On impact (even the slightest) the hammer is driven in, shearing the copper wire and the detonator is fired. The fuze shown in the figure is a variant, No. 106 E, in which, owing to the inherent sensitiveness of fuzes of this class, a safety shutter is introduced. This shutter, like that of No. 45 alluded to above, carries a composition relay.

No. 106 and its variants were the standard instantaneous fuzes of the British artillery in the World War. Introduced in 1916, some 88,000,000 were made, and at the end of the war they were being turned out at the rate of a million a week, about one-third of those being made of cast iron.

No. 146, also armed by an unwinding tape device, is known as the "All-ways" fuze. It is designed to act and burst its shell at whatever angle the latter may strike the ground. It is used only for trench-mortar bombs. For rifled shells, which travel nose first, such a fuze is not necessary, but for many trench-mortar bombs, which may fall sideways or on their bases, a percussion fuze is impracticable unless it possesses this characteristic. Fig. 5 shows the final form of the British "All-ways" fuze developed in the war from a crude German archetype. It is called No. 146 MK. V, or the Spigot fuze, as it is screwed on to a spigot which projects from the bomb.

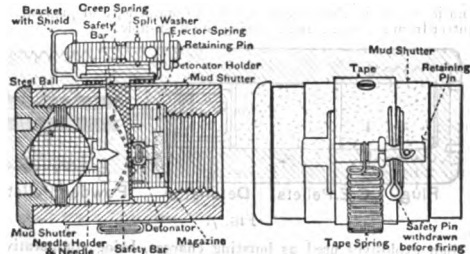

FIG. 5.

On firing, the shock of discharge dislodges the retaining pin and the tape spring causes the tape to unwind, thus permitting the ejector spring to eject the safety bar from the body of the fuze. The "mud shutter" then drops and closes the hole in the body, thus preventing the interior of the body from being filled with mud on falling to the ground. Only a light strip of spring steel now keeps the detonator and the needle apart. On impact one of two things takes place, whatever the angle of fall. Either the steel bar forces the needle holder down on the detonator, or the latter moves forward carrying its detonator on to the needle.

Graze Fuzes rely for their action on the check to the forward movement of the shell that takes place on graze or impact, and not essentially on a blow delivered to any part of the fuze. They are therefore very sensitive and depend for their action on a pellet inside the fuze which moves forward on graze, causing a needle to come in contact with a detonator. Special arrangements are provided to guard against premature action in transport, handling and loading, on discharge, while the shell is in the bore, and during flight before it strikes or grazes. With these fuzes there is always a slight delay in action, and in some cases an additional delay-action is provided which is sufficient to cause the burst to occur well below the ground surface, or, if the shell ricochets, 10 to 50 yd. in front of the graze. In view of the danger to equipment and to personnel in the event of such a shell exploding prematurely, there is incorporated with the fuze either a shutter or a "delay," either of which modifications (to be described subsequently) should ensure the burst of the shell not taking place until it is some distance clear of the gun.



An example of this class is the British Fuze No. 101 E. It will be seen in fig. 6 that the detonator is contained in the graze pellet. With this arrangement it is possible for the needle to fire the detonator when the cap is crushed in on impact (although the graze pellet may not have acted).

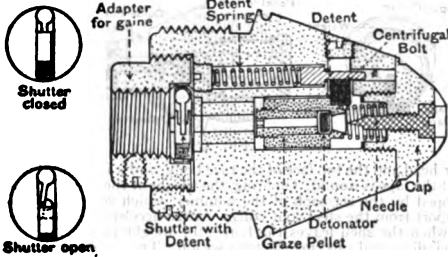

FIG. 6.

The shock of discharge causes the detent to set back, compressing its spring. Then the detent spring, reasserting itself, jams the point of the detent under the projecting shoulder, so that it cannot return to its original position blocking the centrifugal bolt. This bolt, actuated by the rotation of the shell, moves outwards, freeing the graze pellet. The latter is restrained from working forward during flight by a creep-spring. On graze or impact the pellet, overcoming the creep-spring, flies forward, and the detonator is fired by coming in contact with the needle. The flash passes into the "gaine" and this detonates the shell.

In the earliest models of the same class the detent alone was relied upon to give safety, but in the fuze illustrated and also in others, as an additional precaution, a shutter is introduced to mask the flash-hole until the shell is clear of the gun. This consists of a block held in the closed position, with its centre of gravity eccentric to the axis of the fuze, by a compressed spring and a detent with a weighted head. While the shell is going forward in the gun, the shutter is held in position by the spring, but on leaving the gun the rotation of the shell overcomes the spring, and the shutter moves outwards, uncovering the flash-hole; at the same time the tail of the detent is released from its recess in the shutter, moves to one side, and prevents the shutter from returning and masking the flash-hole.

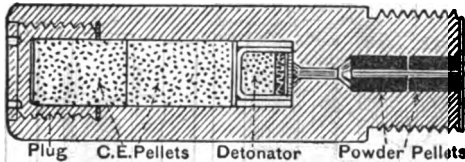

FIG. 7.

High explosives used as bursting charges, being comparatively inert and safe substances, require a violent detonation actually in contact with them to ensure that they shall detonate and not merely explode. This result is obtained by interposing a certain amount of less inert explosive between the bursting charge and the magazine of the fuze. In some cases this relay or part of it is placed in a steel or bronze container called a "gaine," which is screwed to and forms an integral part of the fuze.

Fuzes of the class described here are always used with a gaine (which is screwed into an adapter and so secured to the base of the fuze), the flash being inadequate in itself to secure detonation of the contents of the shell without being assisted by a relay. The internal arrangement of a gaine for use with these fuzes will be seen in fig. 7. The flash from the fuze ignites the perforated pellet. The flame from this passes through a flash-hole to the detonator, which, when fired, detonates in its turn two pellets of exploding composition (C.E.) or of picric acid, and these finally detonate an "exploder" bag placed choke downwards below the gaine in the cavity of the bursting charge. This train of three detonations detonates the H.E. in the shell. When a delay composition is included it is placed at the mouth of the gaine, above the powder pellets.

**Base Fuzes.**—These are for use in shells having solid-pointed heads. That in general use for common-pointed and armour-piercing shells comes under the category of graze fuzes and is known as Fuze Percussion, Base large, No. 11.

The pellet is locked by a device which primarily releases it when acted on by the pressure of the propellant gases, its final release being accomplished by the rotation of the projectile. Safety shutters prevent the magazine from being fired should the detonator act prematurely.

The pellet is locked in its rearward position by a bolt projecting into a recess in its body, and is held in this position by the stem of the pressure-plate. This plate is fitted into a socket, and is made accident-proof by a steel protecting plate, perforated so that the gas pressures may act on the pressure plate.

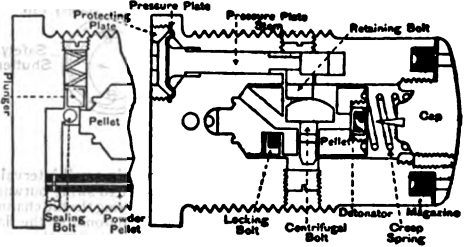

FIG. 8.

When the pressure plate is driven in on firing, a recess in the stem is brought opposite to the fork of the retaining bolt, so that this is now free to move outwards. The mushroom-headed centrifugal bolt moves outwards on rotation being set up, and forces the end of the retaining bolt into the recess exposed by the movement of the pressure-plate stem. At the same time the tail of the centrifugal bolt—which hitherto, by engaging in a recess in the body of the fuze, has prevented the rebound of the pellet on shock of discharge—is withdrawn and the pellet is now free, its movement being only controlled by the creep-spring.

On impact the pellet moves forward and the needle penetrates the detonator. The flash from this passes through a passage in the pellet and centrifugal bolt, along a transverse channel, and ignites a vertical column of compressed powder leading to the magazine. This is a ring of compressed powder in a recess in the upper part of the fuze body, the powder being grooved on the under side so that the flash may pass all round and ignite the whole ring simultaneously. The flame from the magazine passes through holes in the cap to the bursting charge of the shell.

Premature action on this fuze is guarded against in three ways: First, the spindle of the centrifugal bolt masks the passage through the pellet until the shell has gained a suitable speed of rotation; secondly, the coned seating at the base prevents the escape of flash coming over or through the pellet; and thirdly, a ball in a seating at the end of the transverse channel is held in position by a spring-controlled plunger that moves outwards, the ball following it when sufficient rotary movement has been set up.

To prevent a "blind" being caused on impact by the rebound of the pellet there is a spring-controlled locking bolt in the side of the pellet so arranged as to enter a recess in the body of the fuze when the pellet has gone forward a certain distance; this permits of further forward but no backward movement or rebound due to the creep-spring.

One of the earliest and simplest of the base fuzes is the Base Hotchkiss Fuze (fig. 9) used mainly for small Q.F. guns.

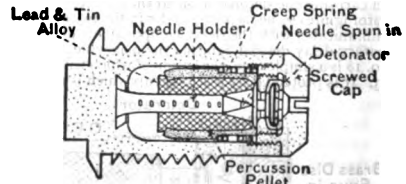

FIG. 9.

On the shock of discharge, the pellet sets back over the needle holder, thus allowing the steel needle to project beyond it. The alloy at the bottom of the pellet cushions against the bottom of the fuze, and a small portion of it dovetails into the undercut recess, round the base of the needle-holder. This forms a weak connexion between the pellet and fuze body, and assists the spring in checking rebound action. On graze or impact, the pellet and needle set forward, the needle pierces the detonator, and the flash passes through to the bursting charge of the shell.

**Time and Percussion Fuzes,** as their names imply, are intended to burst their shells either in the air in front of the target or on impact. Setting aside for the moment the newly developed clockwork fuzes, the T. and P. Fuzes used in Great Britain depend for time of burning on rings of compressed composition which are ignited at the moment of discharge, and of which the flame is conducted by suitable passages to the magazine. The opening charge of the shrapnel is thus fired at a moment predetermined by the setting given to the time rings above

mentioned, one of which is movable, the other fixed to the body. The rings are pressed together by the cap of the fuze, which is screwed down tightly enough to prevent the movable ring from being shifted otherwise than by a spanner called a "fuz key," so as to ensure regular adjustment of the ring and to prevent it from slipping after being set. Many factors govern the rate of burning of the time rings. Primarily there is the pressure prevailing at the burning surface; this again depends on the pressure produced by the burning composition at the escape outlets, and this again depends largely on the speed of revolution and of translation, the position of the outlets with regard to the body of the fuze, the shape of the fuze, the height to which the shell is fired, the barometric pressure, and the nature of the gun from which the shell is fired.

Time and percussion fuzes are used normally with shrapnel, but rarely with H.E. shell.

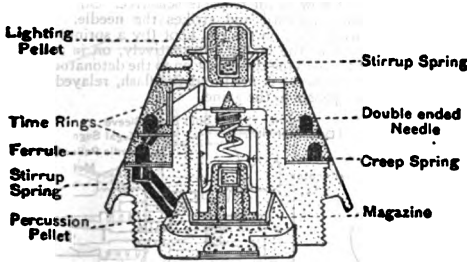

FIG. 10.

In the Time and Percussion Fuze No. 80 the upper time ring is fixed to the body by pegs, but the lower ring can be rotated for setting (fig. 10). Immediately below the cap is the mechanism for igniting the composition. This consists of a lighting pellet fitted with a detonator and supported by a stirrup spring which keeps it away from the needle below it.

On shock of discharge the pellet sets back, straightening out the arms of the stirrup spring, and the detonator comes in contact with, and is fired by, the needle. The flash from the detonator passes through a slanting channel and ignites the composition in the upper ring. The flame then travels in the direction in which the shell is rotating until, after an interval of time determined by the setting, it reaches a passage communicating with the lower time ring. Here there is a compressed powder pellet to ensure more certain ignition. The composition in this second ring, being thus ignited, burns in the reverse direction until, at the time determined by the setting, it reaches the compressed powder pellets in a passage leading to the magazine, the flash from which, passing down a tube in the shell, fires the opening charge.

The percussion pellet is held away from the lower point of the needle by a ferrule supported by a stirrup spring, a creep-spring preventing any forward movement during flight. On graze or impact the percussion pellet flies forward, and the detonator, impinging on the point of the needle, fires, and its flash passing through the pellet fires the magazine.

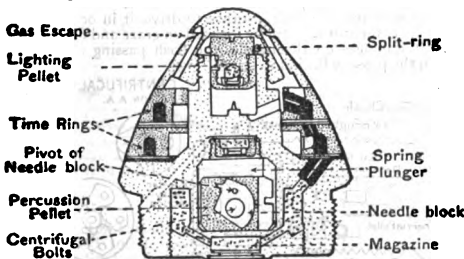

FIG. 11.

In general arrangement Time and Percussion Fuze No. 85<sup>1</sup> greatly resembles No. 80. There are, however, some important differences (fig. 11).

The lighting pellet is supported by a ring sprung into a groove in the pellet and resting on the rim of a recess in the stem of the body. On the shock of discharge the pellet escapes from the ring and sets back on to the needle which fires it, the flash igniting the time ring as in Fuze 80. Another interesting characteristic of this fuze is that the

<sup>1</sup> This fuze, worked out by J. D. Cushing, was the American army fuze before the World War, and was used in large quantities for British field guns to supplement the available stocks of British fuzes.

gases, instead of escaping directly through holes in the rings, pass into a series of channels before finally escaping through a circumferential groove in the cap. With this modification the rate of burning of the time ring is less affected by variations in barometric pressure and the other disturbing factors above mentioned. The main difference between these two fuzes is, however, in the percussion arrangement. This consists of a pivoted needle pellet or block and a detonator supported in the upper part of the recess. The block, which is free, is kept in position by centrifugal bolts. These in due course free the block, which swings round on its pivot, bringing the needle opposite the detonator. Spring plungers prevent the pellet from creeping forward in flight. On graze or impact it flies forward, overcoming the spring plungers, and fires the detonator. The flash from this passes down a passage in the body (dotted lines) and fires the magazine.

In T. and P. No. 83, a variant designed specially for medium guns and howitzer, a special safety device is provided in the shape of a ball, which is trapped between the ferrule and the detonator pellet and the striker until the ferrule sets back, when the ball acts as a temporary safety between pellet and striker. When sufficient rotation has been set up, the ball flies up into a side channel, and the pellet is now only held back by a creep-spring which on impact is overcome.

Time fuzes without percussion elements are now of no special interest except in connexion with anti-aircraft fire. It is essential to render all shell fired at aircraft that might fail to burst in the air as harmless as possible on impact with the ground, owing to the danger to friendly troops and the populations of towns and villages, and buildings. Another use of time fuzes without percussion mechanism is with trench-mortar shell, which do not pitch nose first. In these and a few other special cases the ordinary stirrup spring is too stiff to arm, and a weaker spring is fitted with, as its corollary, a safety-pin for security in transport. All such time fuzes are simply T. and P. Fuzes of the various service patterns converted by the removal of the P. mechanism.

In general the time fuzes designed before and used during the World War were constructed to run for 22 seconds' time of flight. In fuzes for certain longer-ranging ordnance, however (e.g. No. 83), 30 and 45 seconds' run was allowed for, and the latest representative of this class, No. 89, which has three time rings instead of two, runs for 60 seconds. Amongst all these No. 80 was by far the most generally used, about 70,000,000 of this type having been manufactured during the war, as well as 18,000,000 of the American No. 85 and 8,000,000 of Nos. 83, 88 and 89. As an instance of how the industry of the country adapted itself to war needs, it is worth mention that the average pre-war output of No. 80 was 55,000 a year, and the output of one firm alone in 1918 250,000 a week.

Last, and for the future most important in the time-fuze category, comes the mechanical or clockwork fuze. This almost eliminates the variations of burst due to atmospheric conditions and to the quality and freshness of the composition used. It had long been sought for by inventors, but until 1916 no type had been produced which gave satisfactory results in practice owing to the great difficulties in designing a mechanism that would run under the conditions of shock and of rotation that a fuze must cope with.

In 1916, however, the Germans brought into use a clockwork fuze, ("Dopp. Z. 16") which proved very successful and has been copied, with little variation, by the British authorities, its British designation being Fuze, Time, No. 200. The German fuze has a percussion arrangement in addition to the clockwork; this is omitted in the British model, which is a time fuze only.

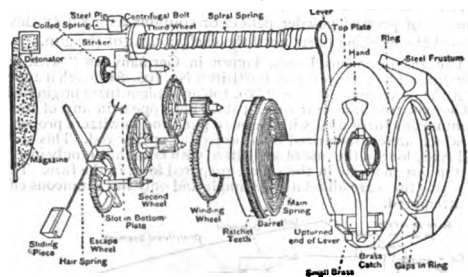

FIG. 12.

The description which follows must be understood as a description of principle and arrangement only, a technical demonstration being impossible without the actual fuze. It must be premised further that the clockwork element is very small in size, being in diameter about equal to an ordinary wrist watch and in thickness to two such watches.

Fuze, Time, Mechanical, No. 200.—The clock train is driven, as in a watch, by a coiled spring in a barrel, but the escapement is original and peculiar. A straight steel spring takes the place of the hair-spring,

which would be rendered useless by the effect of rotation and shock of discharge, and as the length of the straight spring is adjustable, the movement of the pellets of the balance, and therefore that of the escapement wheel and the position of which depends on the setting of the fuze, has on its under surface a notch into which fits the upturned end of the lever at the top of the striker. When the clock train is started the hand moves round with it, but is prevented from rising and releasing the lever by a ring attached to the conical housing of the fuze. This ring is provided with two slots into which the hand can fit; thus when the clock is working the rotation brings the hand into coincidence with the slots, and when forced up by the action of a small spring, it releases the upturned end of the lever. The striker previous to firing has been held in the safe position by a collar on it which rests on a shoulder of the centrifugal bolt, but when this bolt is moved away by the rotation of the shell, the outer part of this shoulder still rests on a steel pin. When the upturned end of the lever is freed from the notch in the lower side of the hand, as previously described, it flies out and rotates the striker so that the collar clears the steel pin and allows the striker to fall and fire the detonator.

The setting of the fuze and the hand is accomplished by turning the housing with a suitable key, this housing being free to move before firing. On discharge it is very ingeniously clamped to the body of the fuze by means of steel pins in a ring in its under surface. This ring sets back and the pins are driven through the flange of the clock case, a groove being turned on its under side to thin the metal, and thus to allow of easy penetration.

The clock train, wound up like a watch, is started at the moment of firing by the setting back of a detent.

The British fuzes described above illustrate sufficiently the general principles on which fuzes are designed to serve the various requirements and to meet the various dangers. There are, however, many interesting devices and expedients included in the design of French, German and other fuzes which are not usually employed in Great Britain, and the fuzes described below have been selected as examples of these devices and expedients. Some of these have been copied by British designers.

*German Fuzes* in general have some marked peculiarities. In the first place, especially in pre-war designs, there is a tendency to excessive complication, due to the desire to make one fuze answer for several functions. Ignoring the case of fuzes for universal shell, in which the complication resides rather in the shell itself than in the fuze, we find fuzes designed for time, impact and delay, or impact, delay and long delay, each system having its own equipment of safety devices as well as suitable setting arrangements. In some cases the channels bored into the fuze body with their cross-connecting channels and sealing devices are so numerous that the interior resembles a veritable rabbit warren. One example only of these complicated fuzes will be described here.

On the other hand, some of the devices employed are elegant in their simplicity, notably the interlocking shutter-leaves described in two of the examples below. Other points of special interest found in German fuzes are—in time fuzes the provision of devices to lock the movable time ring by set-back; and in percussion fuzes (and the percussion element of T. and P. Fuzes) the use of pressed powder pellets or columns as a safety device to seal the working parts until the shell is clear of the gun.

The instantaneous fuzes, known in Germany as "sensitive" (*empfindlich*), are quite unlike the British No. 106. Although it appears that the unwrapping device of No. 106 and spigot fuzes originated in a German trench-mortar fuze, it does not appear in any of the instantaneous fuzes used with German guns and howitzers proper, all of which are characterized by a projecting striker rod. This striker rod (very long in the case of shell fitted with false cap) is only inserted at the last moment in the socket prepared for it in the fuze. These sensitive fuzes are all relatively simple and only instantaneous effect is attempted.

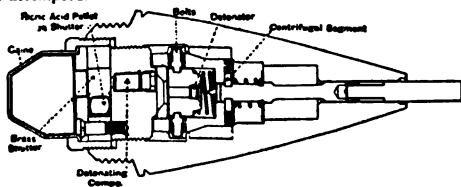

FIG. 13.

The Instantaneous Howitzer Fuze 16 C. (E.H.Z. 16 C., fig. 13) is fitted with a projecting striker rod so that the fuze comes in contact

with the ground, etc., a moment before the shoulders of the shell do so, thus detonating the shell before it has time to bury itself. The removable rod fits into a rod which is supported by a creep-spring at its lower end and held in position up to the moment of firing by two centrifugal spring bolts. Below the point of the needle is a small detonator in a holder also kept in position by two centrifugal spring bolts. Below this again is the main detonator, to which the flash from the smaller one is communicated through a suitable channel. This main detonator communicates with the gaine by a fire-hole, but is screened from it by a centrifugal brass shutter, in which—out of line with the detonator-gaine fire-hole—is a charge of explosive.

On rotation being imparted to the projectile the striker needle is freed, as is also the detonator holder below it, and these are then only held apart by the creep-spring. The brass shutter swings outwards, bringing the explosive patch to its position under the main detonator. The fuze is now in all respects sensitive. On graze, the detonator holder flies forward and strikes the needle, which is solidly supported by a plate on the rod kept (by a spring) bearing against shoulders cut in the body. Alternatively, on impact, the striker rod is pushed in, driving the needle on to the detonator holder. In either case the detonator is fired and the flash, relayed by the patch in the shutter, passes to the gaine.

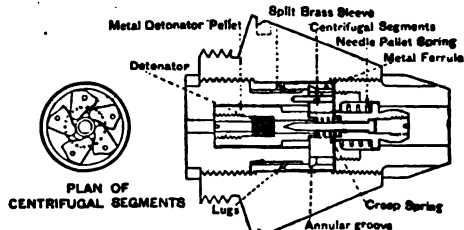

FIG. 14.

In the instantaneous fuze "Granatzylinder 17" (Gr. Z. 17), shown in fig. 14, the body is fitted in its lower portion with a bush carrying five centrifugal segments, a split brass sleeve and ferrule, and a detonator holder, to the top of which a creep-spring is soldered. The upper half of the fuze contains a needle pellet and spring; the upper part of which is shaped to take the striker rod, and has projections that, by a spring, are kept bearing on shoulders formed in the body, as in E.H.Z. 16 C. On the shock of discharge the ferrule sets back, overcoming the support of the brass sleeve, and is locked in its rearward position by lugs on the sleeve which engage in an annular groove in the inner surface of the ferrule. The centrifugal segments are now free to take up rotation about their pivot pins, but as they are interlocked, owing to their shape and position, they can only move one at a time, and thus an appreciable interval elapses before the percussion pellet is free. The extremities of the centrifugal segments (aided by the needle-pellet spring) take up the set-back of the needle pellet on shock of discharge, and the creep-spring keeps the percussion pellet away from the needle during flight. On impact the striker rod is driven in and impels the needle pellet, which, overcoming the resistance of its supporting spring, fires the detonator. Should the striker rod meet with insufficient resistance to drive it in on impact, the percussion detonator will still fly forward on graze and fire its detonator as it impinges on the needle, the flash passing into the shell through the passage behind it.

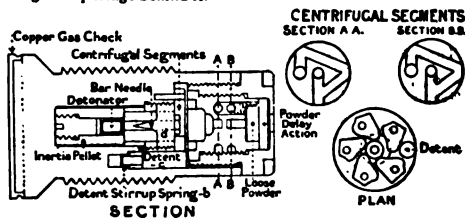

FIG. 15.

This shutter device is also found in an interesting German base fuze (fig. 15), in combination with a detent of the same class as that of the British 101 Fuze, but reversed.

The fuze depends for its action on the inertia of a pellet which remains steady till impact, and then sets forward on to the needle. In travelling, the movable pellet is confined between the shutter and the bottom of its cavity, and set-back on discharge does not affect it. But as soon as the shutter-leaves rotate out of the way it is perfectly free, not even a creep-spring apparently being fitted. On firing the detent flattens its stirrup spring, and sets back, and thereupon, under

centrifugal action, the leaves of the shutter, one by one, rotate clear of the head of the inertia pellet. This is of a peculiar design, only found in German fuzes. On two sides the mass of the pellet is continued upwards to form walls or guides, and between these guides is the needle, mounted on a fixed bar. In the upward motion of the pellet, therefore, the detonator carried with it is impelled straight on to the needle. A further peculiarity is to be noticed in the top part of the fuze. This is a delay-action fuze, and in order to damp the violence of the detonator its flash is compelled to follow a long and tortuous channel before it can reach the loose powder which ignites the delay pellet.

German percussion fuzes with optional delay are generally very elaborate; examples, however, may be given of the simple types. In the 1916 Howitzer Fuze (H.Z. 16) shown in fig. 16 the usual

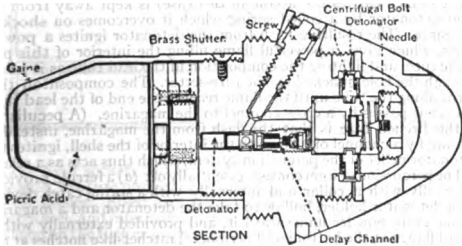
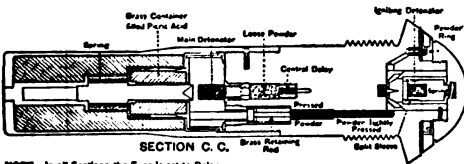

FIG. 16.

elements—a fixed needle and a movable pellet held by centrifugal bolts, a creep-spring and a shutter containing a relay pellet—appear, and need not be further explained. The peculiarity of the fuze lies in the fact that between the detonator and this relay pellet the flash has two alternative paths, one direct and the other through a delay composition arrangement, either of which can be put into action in the setting of the fuze. Below the fire-hole into which the flash of the first detonator passes are two channels, into both of which it goes. But if the direct channel is blocked by the screw-in valve, the only passage is through the combination of powder, delay composition, and perforated powder pellet in the delay channel; this gives the required delay. In either case a relay detonator below the junction of the alternative channels passes on the ignition to the patch in the shutter and so to the gaine. The blocking or opening of the direct channel is effected, as the drawing shows, by screwing a simple screw valve home or out.



NOTE—In all Sections the Fuze is set to Delay

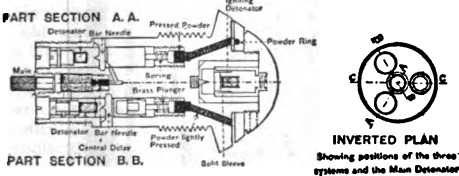

FIG. 17.

The next example is more complicated, and introduces the device, already alluded to, of powder safeties. It is called "1904 Shell Fuze without Striker Rod" (*Gr. Z.04 ohne Vorstecker*), to distinguish it from the same fuze with a long striker rod used with a false-cap shell (fig. 17).

Above the main detonator is a powder arrangement consisting partly of loose powder and partly of delay powder, with two percussion systems of the guide and bar-needle type above described. A hole from the pellet on one side (section A-A) leads to the central delay, while a similar hole from the other pellet (section B-B) leads to the loose powder under the delay, thus giving delay or direct action as required. The two pellets are held away from the bar-needles by brass plungers with springs pressing on the closed-up tops of the pellet extensions, these plungers being themselves held in position by short columns of pressed powder. From these pieces of pressed powder, columns of powder lead to a platform at the upper

part of the fuze body. Here is a movable ring with an annular powder channel on its under side that ignites at will both or only one of the powder columns, in much the same way as the corresponding element of a time fuze. In the upper part of the fuze, placed centrally, is the ignition device. In the lower part of the fuze and in the gaine, also centrally placed, are the main detonator and the gaine elements to be described presently. Through the body of the fuze run three parallel and distinct systems, each of which is seen in one of the three sections shown in fig. 17. Each of these systems communicates with the ignition device in the head, and with the main detonator and gaine below, in a different way.

Centrally in the head of the fuze is the ignition device, analogous to that of a time fuze and consisting of a detonator pellet controlled by a compressed spiral spring cap, and held away from the needle below it by a split brass sleeve. A flash-hole leads from this pellet to the powder channel in the movable ring, and a second flash-hole leads to the third of the internal systems, a powder column passing down the body of the fuze body (see section C-C). This column joins another of rather larger diameter which consists of compressed powder, and acts as a stop to a brass retaining rod. The rod holds down an annular or tubular container situated in the gaine which is centred on a fixed guide rod and has beneath it a compressed spiral spring, to impel it forward when the retaining rod above it is liberated by the burning of the powder safety.

Upon shock of discharge the ignition pellet at the top of the fuze, overcoming the resistance of the split sleeve, sets back on to the needle and fires, the flash passing both to the powder in the movable ring and to the powder column which retains the brass rod (section C-C). When the movable ring is set for non-delay action, the flame passes from the powder in the ring to both the powder columns in sections A-A and B-B, but if set for delay it passes only to the column leading to the delay powder (section A-A). When the compressed powder in the columns is consumed and the plungers are freed, the detonator pellets (or, in the case of delay, that in section A-A) can move forward on impact and will be fired by the needles. Meanwhile, in either case the column of powder in section C-C is consumed, the retaining rod is free to move, and the brass container moves forward under the action of its spring and fits over the main detonator. On impact, if the ring has been set for delay, one percussion detonator (that in section A-A) fires and ignites the central delay, which then burns through and ignites the loose powder below; and so in sequence are fired the main detonator, the container fitting round it, and the gaine. If the ring be set for non-delay, both percussion detonators (A-A, B-B) fire, but as one (section B-B) is in direct communication with the powder below the delay, the main detonator will be fired without any pause; in other words, the fuze behaves as one constructed for direct action on impact.

An objection common to all forms of powder safety is the risk of the powder becoming damp in storage or transport; if the safeties fail to ignite, the fuze will fail to act.

No attempt need be made here to describe trench-mortar fuzes; these are in the main impact or delay fuzes of a simple type designed to arm at low velocities. Practically all German trench mortars were rifled, and of the rest the most important types had either a stick or vane to keep the shell-nose first in descent, so that the difficulty which in England led to the production of the "All-ways" fuze scarcely existed for them. One curious development should, however, be noted—a chemical fuze giving 1, 2, 24 or 48 hours' delay according to the strength of the chemical used. In this, the needle was held off the detonator, against the effort of a spring to decompress itself, by a wire which passed through a container full of corrosive liquid and was secured beyond it to a convenient point on or in the

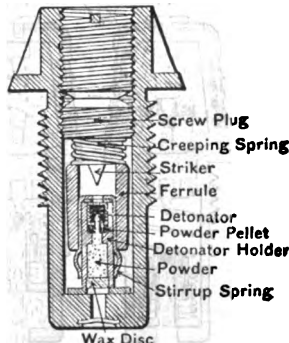

FIG. 18.

body of the fuze. Kept in tension by the effort of the spring, the wire was gradually eaten through by the corrosive liquid, and finally

parted, whereupon the spring drove the needle on to the detonator and exploded the fuze.

(D. D. T. O.C.)

French Fuzes, in marked contrast to German, are deliberately simple in type and the number of types also is limited. The four patterns described below may be taken therefore as fully representative of French practice.

The typical pre-war percussion fuze is the direct-action fuze shown in fig. 18. The action will be readily understood from the figure. Before firing, a heavy ferrule is supported between a compressed spiral spring and a stirrup spring which surrounds the detonator pellet. On shock of discharge (aided by the decompression of the spiral spring) the ferrule sets back, straightening the stirrup spring, and fits over both stirrup spring and detonator pellet, being held there by the spiral spring acting as a creep-spring. On impact the pellet and ferrule fly forward together on to the needle, and the detonator is fired. The spiral spring can be adjusted for tension by screwing the closing plug in or out.

A more highly developed design of the same class is Fuze 24/31 P.R. model 1916, distinguished by an ingenious combination of safety pellet and detonator holder which has been copied in the British Fuze No. 134 (fig. 2).

As in other French fuzes, and in British, impact or delay effect is arranged by the design of explosive filling below the main detonator and not by that of elements in the fuze itself.

French instantaneous fuzes are characterized by simplicity and great projection from the nose of the shell, the latter being intended to ensure that the fuze shall act before the shoulders of the shell strike the ground and begin to bury themselves.

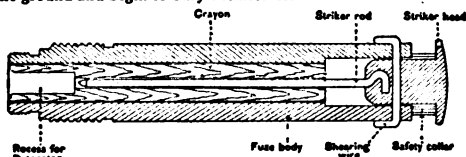

FIG. 19.

A simple representative is shown in fig. 19, which is a cheap and effective trench-mortar fuze. (French trench-mortar projectiles are vanded and so fall nose first.) The striker consists of a head, which in transport is kept off the head of the fuze by a safety ring, and a long striker which is kept centred by a wooden "crayon" in much the same way as the lead is held in an ordinary lead-pencil. Through the head of the striker passes a shearing wire of copper alloy (Cu 67% Zn 33%). Before firing, the safety ring is removed and only the shearing wire keeps the striker point off the detonator. This resists the shock of discharge (which is relatively slight in a trench mortar) but is sheared on impact. It will be observed that the fuze is not sensitive during flight, as the German fuzes and the British No. 106 are, but relies for its instantaneous effect chiefly on the fact that the striker head takes the ground a moment before the shoulders of the shell do so. A fuze of this class when used with a rifled gun would have a centrifugal unwrapping tape similar to that of the British 106 Fuze in lieu of the safety ring. The actual detonator arrangements, not shown, may be varied in the usual way by introducing or omitting a delay pellet. The lower end of the fuze is screwed to receive a steel gaine.

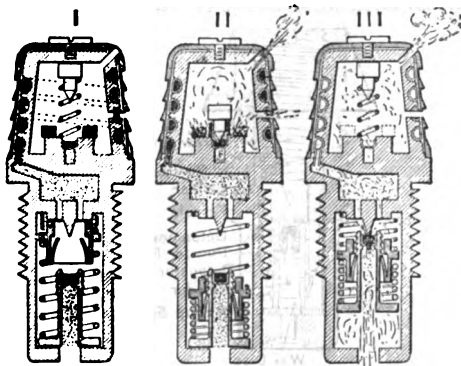

FIG. 20.

The French T. and P. Fuze (*Fuize à double effet 23/31*, fig. 20), designed in 1897, remained in service throughout the war of 1914-8

as the standard time-shrapnel fuze for the 75-mm. field gun. Unlike the British, German, and other T. and P. Fuzes, it is set, not by means of a movable powder ring, but by punching a hole at the appropriate point in a composition-filled lead tube by means of a fuze-setting machine called a *débourchoir*.

The time composition is contained in a sealed lead tube fitting into a spiral groove on the upper and slightly tapered portion of the body. Over the body is a cover on which a long spiral scale is engraved, with graduations corresponding to the appropriate points in the composition worm which lies exactly under it. Certain points on the scale are marked with a hole instead of a figure; these subsequently act as a relief for the gases and slag. To set the fuze a hole is punched by the *débourchoir* through the cover, lead tube, and body, thus making free communication with the interior. The time ignition pellet (which carries the needle in this case) is kept away from the fixed detonator by a coiled spring which it overcomes on shock of discharge. The resulting flash from the detonator ignites a powder pellet, which gives a powerful flame filling the interior of this part of the fuze, and lighting the composition in the lead tube as it passes through the hole punched by the fuze-setter. The composition then burns along the tube until the flame reaches the end of the lead tube, whence it passes by a cross channel to the magazine. (A peculiarity of the French fuze is that the flash from the magazine, instead of passing by a channel of its own to the interior of the shell, ignites the detonator pellet of the percussion system, which thus acts as a relay.)

The percussion system consists essentially of: (a) a ferrule provided externally with a collar and internally with a spring catch device; (b) a detonator holder, hollow to take the detonator and a magazine of fine-grain powder underneath it, and provided externally with a broad flange at the bottom and peripheral ratchet-like notches at the top; and (c) a strong retaining spring and weaker creep-spring. Until the gun is fired the retaining spring, bearing on the collar of the ferrule, keeps this pressed up against the top of the cavity; above the collar the creep-spring is under a slight compression, but this does not affect the security of the fuze. On discharge, the ferrule, overcoming its retaining spring, sets back over the detonator holder, where its internal spring catches engage under one or other of the peripheral ratchet-notches on the holder. The ferrule, compressed spring and detonator holder are now locked together. Held steady during flight by inertia and the creep-spring, on impact they fly forward on to the needle.

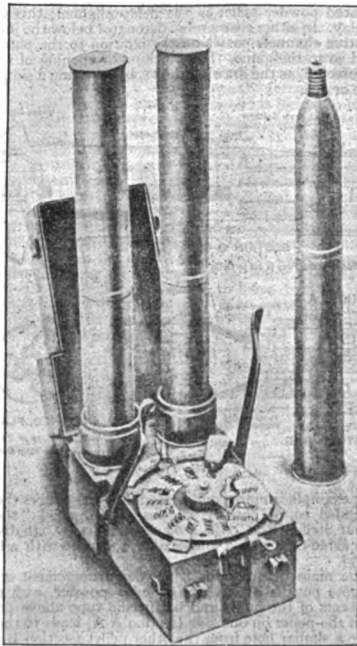

FIG. 21.

In the illustrations, which are diagrammatic, the parts are not to scale, and details (e.g. the centring sleeve for the ignition needle pellet) are omitted so as to show the operation of the fuze more clearly.

The construction and operation of the *débouchoir* or fuze-setting machine are in general terms as follows (figs. 21 and 22):—

A hollow rectangular box contains in its forepart a fixed socket, threaded internally. A second movable socket (the shell holder) is threaded externally in its lower part so as to be screwed up or down

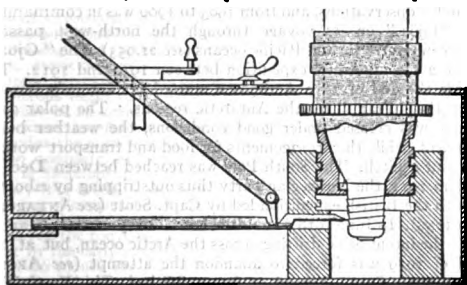

FIG. 22.

in the fixed socket, and formed internally to take the shoulders of the shell, the fuze projecting downwards through a hole in the bottom of the holder. Fixed about the middle of this movable socket is a gear-wheel, and internally, in its bottom, is a small mortise into which a tenon on the fuze engages so that the fuze and shell always occupy a fixed position in the holder. The shell is inserted nose downwards in the holder, secured by the mortise and tenon, and the holder is then, by means of suitable gear in the box operating the gear-wheel, screwed down into the fixed socket, carrying with it the shell and fuze, until the appropriate point in the worm scale of the fuze comes opposite a punching tool in the fixed socket, at which point the tool, operated by an external hand lever, punches the cover, lead tube and body as before described. The amount of screwing-in is determined by the number of turns (or fractions of a turn) of the holder gear-wheel, and the internal gear of the box which actuates this gear-wheel is so controlled by a handle on the top of the box that the position of the handle relatively to a dial on the box exactly represents the position of the fuze scale relatively to the punching tool in the fixed socket. (In practice the handle is set and the holder socket screwed in first, the shell inserted and keyed next, and the actual punching comes last.)

The French service *débouchoir* is made with two sets of elements side by side having a common dial, corrector scale and setting handle, but separate punching handles. This enables two fuzed shells to be set simultaneously for the same time of burning or successively for different times as desired.

**AUTHORITIES.**—No recent book descriptive of fuzes has been published, in the ordinary sense of the word. Information during the war period was circulated only amongst those professionally concerned. The information given above has been collected from various papers and memoranda of this kind, and chiefly from those supplied by the authorities of Woolwich Arsenal, to whom, and to Lt.-Col. G. O. Boase in particular, thanks are due. (C. F. A.)

#### MACHINE GUN, RIFLE AND PISTOL

Since 1910 rapid strides have been made in the improvement of old and development of new designs of ammunition for machine guns, rifles and pistols, principally due to the World War. The manufacture of small arms ammunition, used by the various nations, may be briefly described by outlining the operations necessary to produce a standard cartridge of any one country. In general, these operations would apply to the manufacture of any cartridge, although slight departures therefrom would be necessary where the designs vary. The metallic components of a cartridge are the case, primer (without chemical composition) and bullet.

**The Cartridge Case** is made of cartridge brass which, as produced commercially, contains about 67% copper and 33% zinc. The brass is furnished in strips, coiled in convenient lengths, which are passed through automatic machines to produce metallic cups, from which the finished cases are evolved by a series of processes generally similar to those described for heavy gun cartridge cases.

**The Primer**, inserted in the head of the cartridge case, consists of a cap made of primer brass into which is inserted a percussion composition usually weighing from .25 to .40 grain, according to the character of the composition. After the assembly of the components, the primer is subjected to a drying operation for a short time to

insure that no moisture remains in the chemical mixture. After inspection it is inserted into the primer pocket and a drop of shellac placed in the joint between the primer and the cartridge case to provide water-proofing.

**The Bullet** (unless it be of special type such as armour-piercing) consists of a jacket surrounding a core. This jacket is made from cupro-nickel which, as furnished commercially, contains from 80% to 85% copper and from 15% to 20% nickel. The cupro-nickel is furnished in coiled strips from which by automatic machines cups are produced. These cups are subjected to a series of drawing operations after which the nose and profile of the bullet are formed by swedging processes. The core, of lead hardened with antimony or tin, may or may not be inserted before the bullet jacket is swedged to form. Finally, the composite bullet is resized and prepared for union with the cartridge case.

In assembling the complete round the primed cartridge cases are shellacked in the mouth for water-proofing, and are loaded by automatic machines with a propellant powder charge weighing from 40 to 50 grains. The bullets are then inserted into the mouths of the cartridge cases and secured by crimping the top edges of the cases into the cannelures provided (or otherwise, according to the design of the cartridge in question). Small arms ammunition of the various countries is designed and loaded to give muzzle velocities varying from 2,200 to 2,800 ft. per second, with maximum pressures never exceeding 60,000 lb. (27 tons) per sq. inch. Cartridge clips for quick loading are used in some form with practically all magazine rifles. The number of cartridges in a clip is usually five, placed one above the other. These clips are usually made with a body of rust-proofed steel or brass containing a flat brass spring.

The loaded ammunition, after being weighed, inspected and clipped, is classified and packed according to its future use. In the United States, ammunition passed as suitable for both rifles and ground machine guns is packed for issue in bandoleers made of olive-drab cloth, which generally contain six boxes each holding two clips. In most armies such individual packets of ammunition are put up in larger, metal-lined boxes, the number of rounds packed in a box and therefore its weight varying in different countries according to the preferences of the military authorities in each.

Packing-boxes are provided with watertight metal liners. In the United States the packing-box when loaded with ammunition weighs approximately 110 lb.; in Great Britain (mark VII. ammunition), 75 to 80 lb.

**Ammunition for Machine Guns** may be divided into two general classes: first, that for use in machine guns on the ground; and second, that for use in aircraft machine guns. The extensive use of ammunition for machine guns in the World War involved no new processes of manufacture in order to adapt it to the particular weapons. It did, however, require a more rigid inspection system in order to insure that the ammunition produced was of a quality suitable to stand the wear and tear of machine-gun action.

Ammunition for ground machine guns is generally the same as the standard type used in the shoulder rifle, but more rigidly inspected and tested. Several of the belligerents in the World War developed special types of cartridges having heavier bullets than their standard types for use in machine-gun barrage fire.

A number of special types of machine-gun ammunition have been developed for use by aircraft, all of which have the same overall length as the service ammunition and may be briefly described as follows:—

**The tracer cartridge**, as the name implies, is loaded with a tracer bullet for use with machine guns where, as in aircraft work, it is essential to make the trajectory visible. The bullet differs materially from that of the service cartridge, in that the lead core of the latter is replaced by a conical lead slug in the nose of the tracer bullet jacket, in the rear of which there is inserted a gilding-metal capsule which contains the tracer composition. The ingredients used in the composition are dependent upon the type of trace desired. The red tracer involves the use of strontium salts with the necessary oxidizing agents, while the so-called white tracer gives off a greenish-white flame and involves the use of the barium salts with oxidizing agents. The tracer composition is compressed into the capsule at a pressure to withstand that produced by the exploding cartridge and the length of trace can be regulated by the adjustment of the pressure or amount of oxidizing agents used in the chemical mixture. The composition is ignited by the propellant powder flash and burns with a bright light during a minimum of 500 yd. of flight. Tracer cartridges are generally loaded so as to give the same ballistics as the service ammunition at 500 yards. As these cartridges are placed in machine-gun belts, interspersed with service, incendiary and other types of special aircraft ammunition, a distinctive marking is provided so that inspection may be made of each ammunition belt before the aviator goes into the air.

Owing to the extensive use of observation balloons and dirigibles in the war, the demand was created for an *incendiary bullet* which

<sup>1</sup>The zero of this dial is itself adjustable relatively to a fixed fuze-corrector scale. For the theory of the corrector see 2,692, par. 29 and footnote.



would ignite gases or other materials with which it might come in contact. Omitting technical detail, this form of bullet is organized to contain a charge of yellow phosphorus coated with copper phosphide or aluminium dust in the head. The base is sealed, but a small hole is punched in the side of the bullet and closed with an easily fusible alloy containing a high percentage of bismuth. The heat generated by the passage of the bullet through the barrel of the gun causes this alloy to melt, at the same time causing the yellow phosphorus to become molten. Upon exit from the barrel, the centrifugal force produced by the spinning of the bullet throws the molten phosphorus through the side hole and upon contact with the air the phosphorus burns leaving a trail of smoke and fire streaming from the bullet. Incendiary bullets burn over a range of approximately 300 yd. and are so loaded as to shoot similarly to service ammunition at that range. Incendiary cartridges are distinguished from other types of ammunition by special markings.

The use of various standard-calibre incendiary bullets against observation balloons and dirigibles was supplemented by the development of a larger calibre (11 mm.) *tracer incendiary cartridge* for use at longer ranges. The bullets are generally turned out of solid brass rod and are approximately 1.34 in. long. The tracer incendiary composition produces a white or a red flame according to the chemicals used. This composition is mixed and compressed into the brass bullets so as to withstand the pressure of the cartridge when fired. The flame from the propellant ignites the composition, which burns for at least 1,200 yards. The cartridge case is of the rim type and is loaded with a propellant to give a muzzle velocity of 2,000 to 2,350 ft. per second.

Combinations of the various types of bullets described above have been tried out experimentally with different degrees of success. The inspection of all of these types is very rigid, as all ammunition for aircraft use must be specially selected, in particular because hang-fires may be dangerous in aircraft machine guns synchronized with the propeller.

Many types of *armour-piercing bullets* were used during the World War in order to attack the light armour-plate of aeroplanes, tanks, etc. This class of bullet, with its steel core, required considerable experimental work and may still be considered as in the development stage. It consists principally of a cupro-nickel jacket, inside which is a hardened steel core incased in a lead envelope. The action may be briefly described as follows:—

Upon striking the armour-plate, the jacket splits and a portion of the lead in the nose of the bullet is trapped between the hardened point of the steel core and the surface of the hardened armour-plate. This soft mass of lead produces a protective coating for the nose of the steel core and thus aids penetration. The bullet is loaded into the same case as the service ammunition and is distinguished by special markings. A larger calibre of armour-piercing ammunition was developed by the Germans for the 13-mm. anti-tank rifle (see *RIFLES*). The bullet was of the armour-piercing type and weighed approximately 800 grains, while the cartridge case was of the semi-rimless type with a propellant charge of about 200 grains. This cartridge developed a muzzle velocity of about 2,450 f.s. and was very effective against tank armour. Further developments along this line may be expected in the future.

*Ammunition for Rifles.*—Each country has its standard rifle cartridge which is of the same shape and size and is manufactured in the same manner as the machine-gun ammunition above described. Some of these cartridges are of the rimmed while others are of the rimless type. The standard calibres vary from .25 in. to .32 inch. Various other types have been developed for guard, test, and training purposes, such as the blank, dummy, guard, high-pressure, and gallery-practice cartridges.

*Ammunition for Pistols.*—The ammunition used in various countries in automatic pistols is very similar, and a description of the manufacture of the United States type may be considered to be representative of all others. This cartridge consists of a drawn brass case with a primer inserted in its head. The bullets, as a rule, have jackets made from drawn gilding metal or some other suitable material. The manufacture of the cartridge case and bullet-jacket follows, in general, the process outlined for the manufacture of the rifle-cartridge components except that the number of operations is considerably reduced. The bullet is .45 calibre, weighs 230 grains and has its jacket tinned and filled with a core of lead hardened with about 2% of antimony. The cartridge cases are all of the rimless type and have a small cannelure located on the cartridge case in such a position as to prevent a bullet from being pushed back into it. All pistol ammunition is loaded to give low velocities as compared with rifle ammunition. Calibre .45 cartridge, used by the United States, has a muzzle velocity of 800 f.s. and develops a maximum pressure of 16,000 lb. per sq. inch. In addition to the pistol cartridges of the service type, there are blank and high-pressure cartridges for instructional and testing purposes. The ammunition made for automatic pistols of smaller calibre, used by travellers, police and others, is in principle similar to that of the heavier .45 pistol. (W. L. C.)

**AMUNDSEN, ROALD** (1872— ), Norwegian polar explorer, was born at Borge, Smaalene, Norway, July 16 1872, the son of a shipowner. He was educated at Christiania and afterwards

studied medicine for two years. Later, however, he went to sea, and from 1897 to 1899 served as mate on the "Belgica" with Capt. Adrien de Gerlache's Antarctic expedition. In 1901-2 he made an expedition to the Arctic regions which resulted in some valuable observations, and from 1903 to 1906 was in command of the "Gjøa" on its voyage through the north-west passage between the Arctic and Pacific oceans (see 21.953). The "Gjøa" made a second Arctic expedition between 1910 and 1912. Towards the end of 1910 Amundsen started in Nansen's famous ship, the "Fram," for the Antarctic regions. The polar continent was crossed under good conditions, the weather being excellent, while the arrangements for food and transport worked without a hitch. The South Pole was reached between Dec. 14 and 17 1911, the Norwegian party thus outstripping by about a month the British expedition led by Capt. Scott (see ANTARCTIC REGIONS). In June 1918 Amundsen left Norway in the "Maud" with the intention of drifting across the Arctic ocean, but at the end of 1919 was forced to abandon the attempt (see ARCTIC REGIONS). Capt. Amundsen has published *The North-West Passage* (1907), and *The South Pole* (1912), and has received many honours from learned societies.

**ANAESTHETICS** (see 1.907).—In connexion with the progress made in 1910-20, it is somewhat remarkable that the agents for producing general surgical anaesthesia which were the first to be introduced, that is, nitrous oxide gas, ether and chloroform, not only remained in general use, but actually proved in greater part for the requirements of modern surgery. "Regional" anaesthesia, or analgesia as some prefer to call it, had, however, in part supplanted "general" anaesthesia. It consists in abolishing sensation in a restricted part of the body without affecting consciousness; it is effected by "blocking" the conduction of sensation through the nerves supplying the area concerned by applying to them a solution of a drug similar in constitution to cocaine, or by injecting this solution into the lower part of the spinal canal and so blocking the sensory fibres in the nerve roots and in the spinal cord itself. Regional anaesthesia has, however, as yet only a limited application, for although adopted as a convenient routine measure in some classes of cases and types of patients, yet it has been found by experience to have certain limitations, and in the case of spinal anaesthesia certain dangers. Many persons, moreover, prefer the blissful ignorance of a general anaesthesia to full consciousness, and passive submission to a trying ordeal, even when they are deprived of sensation and when the sight of the operation is hidden from them.

General anaesthesia produced by the inhalation of a gas or vapour remains the routine procedure. The use of non-volatile drugs, such as morphia or hedonal, introduced by the mouth or by subcutaneous or intravenous injection, is not readily subject to control; once introduced these substances remain in the body until slowly excreted by the kidneys; the dose can be increased but it cannot be decreased, and herein lies a danger. Inhalation anaesthesia on the other hand is susceptible of the most delicate adjustment to requirements. The pulmonary route is adapted anatomically to meet the vital requirements of the absorption and excretion of the blood gases, oxygen and carbon dioxide, and is hence perfectly adapted for the passage to and from the blood of other gases and vapours. The amount of a vapour absorbed by the blood and the rapidity of its absorption are both proportional to its concentration in the atmosphere inhaled into the lungs<sup>1</sup> so that the task of the anaesthetist is mainly one of adjusting the strength of the vapour according to the result which is desired. So also the amount which has been introduced into the blood can be rapidly reduced; it is partially exhaled on diminishing the strength of the vapour presented to the blood, and it becomes totally exhaled on withdrawing the vapour entirely from the inhaled atmosphere. This facility of the adjustment of anaesthesia is not shared by any other method, and it appears likely to sustain inhalation anaesthesia in its present predominant position for some time to come.

<sup>1</sup> In the case of chloroform there is a deviation from the laws of the solution of vapours, but this is negligible at the low concentrations employed for anaesthetic purposes.



**Nitrous Oxide.**—One of the surgical lessons of the World War was that persons suffering from severe shock and loss of blood from wounds did not progress favourably following operation under chloroform or ether, but that the prospects of recovery were distinctly improved when performed under the continuous inhalation of nitrous oxide gas. The reasons for this cannot be stated precisely, but it may be said in general terms that nitrous oxide is less depressing, and further that owing to its exceedingly rapid excretion, consciousness and normal bodily conditions are quickly restored after completion of the operation.

Nitrous oxide, or "laughing gas" as it was formerly termed, is familiar as an agent for producing brief periods of narcosis, as for the extraction of teeth. When administered thus in a pure state it excludes the admission of air to the lungs, and if continued would cause complete asphyxia, the problem of continuous administration is therefore the admission of sufficient oxygen to the lungs to satisfy the needs of the body. Air contains about one-fifth of its volume of oxygen, but if nitrous oxide were diluted to this extent its partial pressure would be reduced to about 80%, which is too weak for the convenient production of its full anaesthetic effect, at least in the early stages of its administration. It is possible, however, to reduce the amount of oxygen inhaled below the normal quantity without reducing the oxygen in the blood to the same degree; this is due to the fact that the absorption of oxygen by the blood is a process of loose chemical combination with the haemoglobin, which is not governed by the laws of the simple solution of gases. Oxygen may in fact be reduced to a proportion of one-tenth of an atmosphere without causing discomfort to the patient or even under ordinary circumstances causing the discolouration of the face known as cyanosis. It may even be reduced lower than one-tenth and yet be capable of sustaining life. The continuous administration of nitrous oxide mixed with oxygen is thus made possible by the provision of a sufficiently delicate mechanism to regulate and indicate the relative proportions of the gases. One form of indicator which has been generally adopted consists of pressure dials connected with the supply tubes from the cylinders of compressed gases; these register the pressures at which the gases are supplied, and the proportions are in the same relation as the pressure of flow. Another form of indicator is that known as a "sight-feed," in which the gases bubble through a glass vessel containing water, the flow being regulated so that one bubble of oxygen passes for a given number of nitrous oxide bubbles according to desire.

The continuous administration of nitrous oxide and oxygen is not, however, a method which is adapted for all classes of cases; the relaxation of the body muscles is not sufficient for the convenient performance of certain operations, the narcosis is not always sufficiently deep, and it may have to be supplemented by an admixture of ether vapour; nor is it a method absolutely free from danger. Its advantages in the cases of profound shock referred to appear to be undoubted, but how far it can be adapted for general purposes is as yet undecided.

**Ether.**—The use of ether as an anaesthetic has received considerable stimulus from the introduction of the "open" method of administration. In order to induce anaesthesia in a muscular person, or to "get him under" in ordinary physiology, a strong vapour may be required, as strong as 25% to 30% in some cases, and it was formerly supposed to be impossible to attain sufficient concentration from ether sprinkled on a piece of fabric stretched on a frame or "mask." In order to attain this end a "close" method has been in general use, in which the patient breathes to and from a rubber bag over a surface of ether. In this way the vapour becomes concentrated in the bag, but at the expense of the oxygen of the contained air, which becomes rapidly used up, so that the inhaler must be removed periodically to allow of an inspiration of pure air in order to obviate total asphyxia. This method is effective, but far from ideal; the patient is generally more or less "blue" from partial asphyxia throughout the administration, there is a profuse secretion of slimy mucus which must be continually wiped away, the respirations are greatly exaggerated from "re-breathing" the carbon dioxide which accumulates in the bag, and they are often at the same time partially obstructed from the pressure of the closely fitting face-piece. The after-effects are generally unpleasant and not infrequently distressing.

In the "open" ether method the breathing is noiseless, effortless, and only slightly exaggerated, so that delicate abdominal operations can be performed with comfort. The flow of saliva is considerably less than in the closed method (probably from the absence of asphyxia) and this can be entirely abolished by the subcutaneous injection of a minute dose of atropine previous to the administration. There is no sign of cyanosis, and the patient's face remains a healthy colour throughout; the only restriction of oxygen is by reason of the displacement of air by ether vapour which at a maximum will be less than one-third its volume, and as in the later stages of an administration much less vapour is required the restriction becomes entirely negligible. The after-effects of ether, such as vomiting and malaise, are considerably less pronounced than following a "close" administration.

The application of the "open" method to ether inhalation has been brought about by an exceedingly simple adaptation. The liquid ether is applied to a pad of open-weave fabric, such as "stock-

mette" or a number of layers of absorbent gauze, stretched over a framework mask of which the margin is roughly adapted to the contours of the face; the mask rests lightly upon the face, a soft pad being interposed between its edges and the skin to prevent the entrance of air in this direction. In this way the inhaled air is made to pass through the meshes of the fabric, and in doing so every portion of it comes in close contact with the ether, and takes up a greater proportion of vapour than it would if it merely passed over the surface of the fabric, as in the ordinary way of procedure.

The induction of anaesthesia by the open method is liable to be somewhat prolonged, an undoubted disadvantage, but once full anaesthesia has been produced it is maintained without difficulty, and the results attained are in general more satisfactory than those of any other form of inhalation anaesthesia.

The "intratracheal" method of etherization has in recent years been in considerable requisition for special purposes. It is conducted by passing a narrow tube through the larynx into the trachea almost to the level of its bifurcation. Through this tube a continuous current of air and ether vapour is forced into the lungs at a pressure which keeps the lungs moderately distended, but not so much so as to abolish the natural respiratory movements. The air returns through the chink of the vocal cords by the side of the tube, and this continuous return blast blows away any solid or fluid particles, blood or pieces of tissue, in the neighbourhood, and prevents their entering the trachea, an accident which may possibly occur in ordinary inhalation methods. The advantage of intratracheal ether in operations involving the respiratory passages is therefore obvious; it is likewise a convenient arrangement for operations upon the face, which is left entirely uncovered; and in operations upon the interior of the thorax a proper aeration of the lungs can be thus insured.

**Chloroform.**—The form of sudden death which is occasionally encountered under chloroform anaesthesia has acted as a deterrent to its more extended employment in spite of its manifest convenience. An earnest endeavour was made by an influential committee appointed by the British Medical Association to find a method of preventing these chloroform deaths, by enquiring into the conditions of overdose and devising apparatus for the precise limitation of chloroform vapour to essential requirements. The final report of this committee was issued in 1910, but the number of deaths from chloroform has remained practically undiminished since that time. An attempt has further been made to reduce the risk of overdose by diluting the chloroform with ether in varying proportions, but this has proved to be futile as a prophylactic against death, for although the number of deaths under pure chloroform has fallen, the number under mixtures of chloroform has risen ten times that of the year 1910.

It is now becoming realized that the typical sudden chloroform fatality is not conditioned by an overdose at all. It has long been known that the majority of deaths occur in the very early stages of anaesthesia before the patient is fully narcotized, and further enquiry into reports of fatalities shows that there is generally some evidence of light anaesthesia preceding death, or else that overdose can be ruled out of question.

There is a further point brought out by these reports, which was in fact fully appreciated by John Snow in the middle of the last century; whereas in overdose the respiration is paralyzed before the circulation, in the typical chloroform death the outstanding feature is an absolutely sudden failure of the circulation, and the failure of the respiration is a secondary result.

In 1890, Dr. Robert Kirk, boldly and with strong conviction, advanced the theory that chloroform deaths occurred from under-dosage, and although his thesis was supported by important experiments, he failed to formulate an acceptable theoretical basis for it.

Dr. A. G. Levy, in 1911, reported certain cases of sudden cardiac failure which he had observed in animals obviously in a light stage of chloroform anaesthesia, and he succeeded in reproducing this death by the intravenous injection of small doses of adrenalin in lightly chloroformed animals, but the experiment failed under full chloroform narcosis. This at once accounted for those cases of syncope and death, a number of which had been recorded, following the injection of adrenalin into the mucous membrane of the nose for the purposes of certain nasal operations which were always conducted under light anaesthesia, the form of this syncope being the same as in an ordinary chloroform fatality.

By following up this line of research it was shown that sudden cardiac failure could be induced likewise by various procedures—excitation of the cardiac accelerator nerves either directly or through a reflex mechanism, stimulating the excretion of the adrenal glands; by interrupting the administration of chloroform, or by withholding the chloroform during excitement and struggling; the event never occurred during deep narcosis. The underlying condition of the cardiac syncope was shown to be that of fibrillation of the ventricles, in which the ventricles are entirely deprived of their power of propelling the blood through the arteries. The seeming paradox of too small a quantity of a drug being dangerous is susceptible of explanation although the theoretical points have not been fully worked out; a relatively small proportion of chloroform renders the heart "irritable" and liable to assume a sequence of irregular beats which may pass into fibrillation, whereas a larger proportion of chloroform, by reason of its depressing effect, makes

the heart less irritable, and entirely annuls the tendency to fibrillation.

Many years ago J. A. McWilliam expressed the opinion that ventricular fibrillation would be found to account for otherwise unexplained sudden death met with in various conditions, and this demonstration of its occurrence under chloroform is the first confirmation of his views.

On this theory the prevention of death under chloroform can be compassed by simple precautions, by making the induction of anaesthesia continuous and expeditious and thereafter continuously maintaining a full degree of narcosis. Chloroform should never be employed if the conditions of the operation forbid the observance of these rules, and especially in those special cases in which a light degree of anaesthesia is required. These rules are practically a reversion to the injunctions of Simpson, who introduced chloroform as an anaesthetic, and his colleague Syme, in whose experience only one case of death occurred in 10,000 administrations.

Ventricular fibrillation is not always fatal; probably in more than half the cases the heart spontaneously recovers its normal beat, but this happy result can only occur in the first minute or two following the onset of fibrillation. After that time the only prospect of recovery is through the performance of cardiac "massage." This so-called "massage" is a rhythmic manual compression of the heart, producing an artificial circulation; it is combined with an artificial ventilation of the lungs, and so oxygenated blood is supplied to the heart muscle keeping it alive and active, and giving to it a prolonged chance of recovery. In cats this experiment is uniformly successful in bringing about recovery, but in man there have hitherto been only relatively few successes. It appears to be the case that failures have arisen from an imperfect appreciation and application of the principles of cardiac massage, and it is believed that with better knowledge the majority of cases of ventricular fibrillation should prove amenable to this form of treatment.

(A. G. L.)

**ANCONA, ALESSANDRO** (1835-1914), Italian man of letters (see 1.951), died at Florence Nov. 8 1914. In 1904 he had been made a senator. Many of the most eminent contemporary philologists and students of literary history in Italy had been his pupils.

**ANDERSON, ELIZABETH GARRETT** (1836-1917), English medical practitioner (see 1.959), died at Aldeburgh, Suff., Dec. 17 1917.

**ANDERSON, SIR ROBERT ROWAND** (1834-1921), British architect, was born at Forres in 1834, the son of a solicitor. He was educated at Edinburgh and entered the Royal Engineers, where he received his first training as a draughtsman. He subsequently travelled widely in Europe, and later adopted the profession of architect. His first important work was his successful design for the Edinburgh Medical Schools (1875), and this was followed by a succession of important commissions, including those for the offices of the Caledonian railway, Glasgow, and Mount Stuart, Lord Bute's house on the island of Bute (1881-4), the Conservative Club, Edinburgh (1883), the dome of Edinburgh University (1886) and the Scottish National Portrait Gallery (1886-8). He also successfully carried out a series of restorations of Scottish cathedrals, including those of Dunblane Cathedral, Paisley Abbey, Culross Abbey and the interior of Dunfermline Abbey. Many of the best-known monuments in Edinburgh are from his designs, and he was among the architects invited to submit designs for the Imperial Institute (1887), the Queen Victoria Memorial (1901), and the new buildings of the British Museum (1904). In 1901 he was selected to superintend the alterations which were being carried out at Balmoral Castle, and in 1902 he was knighted. Sir Rowand Anderson was in 1876 elected an associate of the Royal Scottish Academy, of which he was in 1896 elected an honorary member. He was also member of the Royal Institute of British Architects and in 1916 was awarded the Royal gold medal for the promotion of architecture. He died at Edinburgh June 1 1921.

**ANDORRA** (see 1.965) had, in 1913, a pop. of 5,210, distributed in 6 communes embracing 44 villages and hamlets. Alt. ranges from 6,562 ft. to 10,171 ft.; alt. of Andorra la Vella, the capital, 7,500 feet. The trans-Pyrenean railway from Ax-les-Thermes (Chemin de Fer du Midi) to Ripoll will pass within 2 or 3 m. of the frontier. A motor road, made by the French from Ax over the Col de Puymorens (alt. about 6,300 ft.) to Bourg-Madame on the Spanish frontier, is tapped by a branch road (under construction in 1912) entering Andorra at Port d'En-Valira (alt. 7,580 ft.), and running down the Valira valley to the capital.

The revenue of the republic, amounting to about 32,000 pesetas per annum, is derived from the sale of wood from the state forests, the rental of summer pastures, a tax on inns and slaughter-houses, a small tax on cattle and a poll-tax. The two suzerain powers receive a biennial tribute—France 1,920 francs and the Bishop of Urgel 920 pesetas; the latter also receives annual gifts in kind from each of the six communes. The principal industry is the raising of cattle, sheep and mules. There is a small tobacco factory at the capital and a considerable amount, of poor quality, is exported to Spain. Wax matches are also made. French and Spanish postage stamps, for the north and south respectively, are in use; the telegraphic arrangements are French. Both French and Spanish coins are current. France has established schools in Andorra, and French influence is in the ascendant.

**ANDRASSY, JULIUS, COUNT** (1860- ), Hungarian statesman, son of the former Minister of the Interior, was born June 30 1860. Deputy (1885), Secretary of State for the Interior (1892), Minister of the Court (1892), he became Minister of the Interior in 1906. As Minister of the Interior, as well as earlier in connexion with the language of command in the Hungarian army and against the régime of Fejervary, he maintained a severe struggle with the prime ministers Khuen-Hedervary and Stephen Tisza. In 1913 he delivered three speeches in the Hungarian Delegation against the conduct of foreign affairs, and in Parliament he opposed the plan for the centralization of the internal administration of Hungary. At the outbreak of the World War he supported the Tisza ministry, but opposed Burian, the Foreign Minister, on the Polish and the Italian questions. In 1915 he pleaded for peace, and urged a wide extension of the franchise. In 1918, as Foreign Minister, he declared the alliance with Germany dissolved, and desired to conclude a separate peace. He retired from office on Nov. 5, was returned for Miskolcz to the National Assembly in Jan. 1920 as a non-party delegate, and later became leader of the Christian National party. In 1904 he was made an associate of the Hungarian Academy of Sciences, in recognition of his distinguished work as a historian.

His works include: *Ungarns Ausgleich vom Jahre 1867* (Hungarian and German, crowned by the Academy); *Die Ursachen des Bestandes des Ungarischen Staates und dessen verfassungsmässiger Freiheit* (3 vols., Hungarian, crowned by the Academy); *The Development of Hungarian Constitutional Liberty* (English); and in Hungarian and German *Wer hat den Krieg verbrochen? Interessensolidarität des Deutschthums und Ungarthums und Diplomatie und Weltkrieg.* (E. v. W.)

**ANDREE, RICHARD** (1835-1912), German geographer (see 1.971), died at Leipzig Feb. 22 1912.

**ANGELL, JAMES ROWLAND** (1869- ), American educationist, was born at Burlington, Vt., May 8 1869. He was a son of James Burrill Angell (d. 1916), first president of the university of Vermont and fourth president of the university of Michigan (1871-1901). He was educated at the universities of Michigan (A.B. 1890; A.M. 1891) and Harvard (A.M. 1892), and spent a year in Europe, chiefly at Berlin and Halle. In 1913 he was appointed instructor in philosophy at the university of Minnesota. In 1894 he was called to the university of Chicago, remaining there until 1920, as assistant professor of psychology and director of the psychological laboratory, associate professor and, after 1905, professor and head of the department. He was dean of the university faculties after 1911 and acting president during 1918-9. In 1906 he was elected president of the American Psychological Association, in 1914 was exchange professor at the Sorbonne, and in 1915 was special lecturer on psychology at Columbia. After America entered the World War in 1917 he was connected with the adjutant-general's office as member of the committee on classification of personnel in the army. He was also a member of the National Research Council, serving as chairman during 1919-20. In April 1920 he was elected president of the Carnegie Corporation of New York. In 1921 he was elected president of Yale to succeed Arthur T. Hadley, resigned.

He was the author of *Psychology* (1903; 4th ed. revised, 1908); *Chapters from Modern Philosophy* (1912) and *An Introduction to Psychology* (1918).

**ANGOLA** (PORTUGUESE WEST AFRICA) (see 2.38).—A census taken in 1914 gave the pop. as 2,124,000, but this total was based on figures supplied by the natives for the purpose of a hut tax,

and did not include regions over which the Portuguese exercised no authority. In 1920 the pop. was estimated, with greater accuracy, at a little under 4,000,000, or eight persons per sq. mile. There were some 30,000 whites, mostly Portuguese. Loanda (São Paulo de Loanda), the capital, had 28,000 inhabitants, of whom a third were whites.

Surveys made since 1909 showed that the part of southern Angola suited for European colonization was larger than had been supposed, and that the plateau, which is free from tsetse-fly, was well adapted to stock raising. Few settlers had been, however, attracted to this region up to 1921 and the development of the whole province was very slow. There was nevertheless an increase in cocoa plantations, chiefly in the Kabinda enclave; coffee, though gathered mainly from wild plants, was also cultivated in the Loanda hinterland and other areas. Rubber was obtained mostly from virgin forest, but ceara, ficus and other trees were planted. Up to 1911 the manufacture of rum was the leading industry; in that year the factories were closed by Government decree, compensation being given to the factory owners and to the planters who grew sugar and sweet potatoes for the production of alcohol. These planters were encouraged to grow sugar-cane for export, and the output for 1913 was 4,600 tons. Subsequently the industry languished. Fish-curing and whaling are lucrative industries. The whalers are Norwegians and Americans and their headquarters are at Lobito Bay. Forestry and mining are both undeveloped, but the syndicate which since 1908 has worked the Kasai diamond area of the Belgian Congo has also concessions on the Portuguese side, and in 1920 the output of diamonds from Angola was estimated at 120,000 carats.

External trade, owing to high protective tariffs, was mainly with Portugal; in the period of 1910-20 it was valued at from £3,500,000 to £4,500,000 yearly, with a tendency for exports to decrease. Rubber, coffee, wax, sugar and palm-kernels, dried fish and whale oil are the chief exports.

Lack of means of transport was a principal cause of the slow progress of Angola. The most important railway (of the standard South African 3 ft.-6 in. gauge), that from Lobito Bay by Benguella across the southern plateau, had reached Bihe, a distance of 323 m. in 1914, when owing to the World War construction stopped. The railway, a British enterprise, was designed to serve the copper mines of Katanga, Belgian Congo, and work on the remaining 480 m. to the Congo frontier began in 1921. A British company acquired large land concessions along the line and started ranches. Farther south a narrow gauge (60 cm.) railway 111 m. long goes from Mossamedes to the Chala Mts., serving a wheat-growing region with European settlements, including one of South African Dutch. In northern Angola the railway (metre gauge) from Loanda was carried to Malanje (375 m.) and was bought in July 1918 by the Portuguese Government.

Excess of expenditure over revenue continued to be a characteristic of the administration, partly because, except for a hut tax on natives, there was no direct taxation. Revenue was almost entirely derived from import and export duties. Deficits were made good by grants made from Portugal and by transfers from the treasuries of such Portuguese colonies as showed an excess of revenue. Annual revenue averaged, on a rough estimate, £500,000 and expenditure £700,000.

*History.*—Southern Angola, in 1909-11, was regarded as a probable choice by the Jewish Territorial Association as a field for colonization, and Portugal enacted land laws with a view to that contingency. But Angola was rejected by the Zionists as a home for Jews. Between 1910 and 1914 chief interest in Angola centred in a very different scheme—the efforts of Germany to include the province in her economic and, ultimately, her political sphere. As far back as 1898 Great Britain had recognized Germany's right to "assist" the Portuguese to exploit southern Angola, but this had not prevented a British syndicate under Mr. Robert Williams from securing the concession for the Benguella (Lobito Bay) railway. On the building of this line from the coast to Bihe over £5,000,000 was spent. A new Anglo-German agreement had been negotiated in 1913-4 and only awaited signature when the World War put an end to the negotiations. The new treaty would have recognized German economic interests as supreme throughout Angola, except in its eastern section (see AFRICA: History). Meantime the Germans had pressed the Portuguese, and with some success, to grant them commercial concessions, and had made offers to buy up the British capital (90% of the whole) in the Benguella railway—offers which were rejected.

In southern Angola itself German agents and so-called scientific missions showed much activity. Not only did its highlands present many advantages for European settlement; the

Kunene river valley, part of which was in German territory, was inhabited by the Ovambo, of whom some 20,000 were recruited by the Germans for work in the Otavi copper-mines. In 1913 the Portuguese forbade further recruiting in Angola; the Germans replied by presenting estimates to the Reichstag in 1914 for £150,000 towards building a railway from Otavi through the Ovambo country and 22 m. of the railway had been built when the World War began. Though Portugal was at the time neutral several conflicts occurred between the Portuguese and Germans in the frontier district. The surrender of the Germans in South-West Africa to Gen. Botha, in July 1915, removed the German menace to Angola and gave the province the British (South Africans) as neighbours on the south.

In an endeavour to break with the tradition that the colonies existed only for the benefit of Portugal the Lisbon Government in 1914 granted them a measure of autonomy. The then governor-general of Angola, Senhor Norton de Mattos, had already instituted reforms and in 1913 had created a Department for Native Affairs, which set itself to regulate the employment of natives, including the recruitment of labourers for the cocoa plantations on St. Thomé and Príncipe Islands. The result was some improvement in the conditions of the natives, but the principle of compulsory labour was maintained, and abuses continued. In 1920 Portugal again endeavoured to set its colonial affairs in order. Another autonomy measure was introduced and Senhor Norton de Mattos was again (Oct. 1920) selected to go to Angola, this time as high commissioner with wide powers.

See *Angola (including Cabinda)* (London 1920), a British Foreign Office handbook with bibliography; Hugo Marquardsen, *Angola* (Berlin 1920), a careful study of the geography and people, by the geographer of the Reichskolonialamt; the *Anuario Colonial* (Lisbon) and the *Boletim of the Lisbon Geog. Society.* (F. R. C.)

#### ANNUNZIO, GABRIELE D': see D'ANNUNZIO, GABRIELE.

**ANSON, SIR WILLIAM REYNELL, 1ST BART.** (1843-1914), English jurist (see 2.84), died at Oxford June 4 1914. In 1909 he signed the minority report of the Divorce Commission, in company with the Archbishop of York and Sir Lewis Dibdin.

**ANTARCTIC REGIONS** (see 21.960).—The expedition planned by Dr. W. S. Bruce for crossing the Antarctic continent in 1911-2, from Coats Land on the Weddell Sea to McMurdo Sound in the Ross Sea, was not proceeded with, and two American expeditions which were contemplated at the same time did not advance beyond the stage of projects.

*Shirase (1910-2).*—A Japanese expedition to Edward VII. Land was fitted out under the command of Lt. Shirase in 1910 and left Japan in that year on board the "Kainan Maru." It entered the Ross Sea too late to make a landing, and after wintering in Sydney returned in 1911-2, when a landing was effected on the Barrier in the Bay of Whales on Jan. 16, but no discoveries were reported and no account appears to have been published in any European language.

*Amundsen (1910-2).*—Capt. Roald Amundsen sailed from Norway in the "Fram" (which had been fitted with internal combustion engines) in Aug. 1910 with the avowed intention of carrying out oceanographical work in the South Atlantic and of proceeding round Cape Horn to Bering Strait, where he proposed to repeat Nansen's drift across the Arctic sea from a more easterly starting-place. The announcement of Peary's attainment of the North Pole in 1909 convinced Amundsen that he could not raise sufficient funds for his proposed five years' absence, and he determined to make a dash for the South Pole in order to raise money for the greater project. His change of plan was announced to the world at Madeira in Sept., and on Jan. 14 1911 the "Fram" was alongside the Barrier in the Bay of Whales, lat. 78° 40' S. long. 164° W. The 116 Eskimo dogs were landed and a hut, "Framheim," erected on the Barrier 2½ m. inland, the point of departure for the Pole being that originally proposed by Shackleton in 1907. On Feb. 15 1911 the "Fram," under Lt. Thorvald Nilsen with nine men, sailed for an oceanographical circumnavigation, with Buenos Aires as the first port of call. Amundsen started on his first depot-laying journey on Feb. 20, and by April 11 had moved 3 tons of provisions to three

depots in  $80^{\circ}$ ,  $81^{\circ}$  and  $82^{\circ}$  S. respectively. A start for the main south journey was made on Sept. 8 but the cold proved too severe ( $-58^{\circ}$  to  $-75^{\circ}$  F.) for the dogs and the party returned to winter quarters for a month. On Oct. 20 1911 (with temp.  $-5^{\circ}$  to  $-23^{\circ}$  F.) Amundsen left again with four companions, Helmer Hansen, Oscar Wisting, Sverre Hassel and Olav Bjaaland, four sledges and 52 dogs. At each original depot they rested a day and gave the dogs a full feed from the stores; but on Nov. 8 they left the depot in lat.  $82^{\circ}$  S., carrying four months' provisions and travelling about 30 m. a day over the smooth Barrier surface, the men using *ski*. At every degree of latitude the sledges were lightened by forming a depot of provisions for the return journey. On Nov. 9 the mountains of South Victoria Land were sighted, and on the 11th another range of mountains was seen joining the Victoria Land range from the direction of Edward VII. Land, and thus forming the southern boundary of the great flat Barrier surface, which apparently did not extend far beyond lat.  $85^{\circ}$  S. On Nov. 17 a large depot was left in lat.  $85^{\circ}$  S. at the base of the Queen Maud range which formed the continuation of the Victoria Land mountains, at a point 200 m. S. of the Beardmore glacier. From this point the climb to the Plateau began through magnificent scenery of glaciers and peaks, the heights of which were estimated as 10,000, 15,000 and even 19,000 feet. A way was found to the summit of the Plateau by the Axel Heiberg glacier which was negotiated by the dogs with much difficulty. Four days were occupied in the ascent to a level stretch at 7,000 ft.; and severe weather compelled a halt at this point for four days more. Here 24 dogs were killed, leaving 18 to work the three sledges. A start due S. was made on Nov. 26 and for two days severe blizzards made it impossible to see the surroundings, but the course lay on a descending gradient. On Nov. 29 a depot with six days' provisions was made at the foot of the Devil's glacier in lat.  $86^{\circ} 21'$  S. On Dec. 1 at a height of about 9,000 ft. the way led over a smooth ice surface on which it was impossible to use *ski*, while under the tread it sounded like walking on empty barrels, and both men and dogs frequently broke through the thin crust of ice. This tract, called "The Devil's Ball Room," proved the worst travelling of the whole trip. Next day in lat.  $88^{\circ}$  S. the highest swell of the Plateau, estimated at 11,000 ft., was passed and in a few days the weather improved, travelling was easy, and on Dec. 14 1911 the position of the South Pole was reached. The total distance from Framheim of about 870 m. was accomplished in 40 days of actual travelling, the average daily distance being 17 miles. After remaining two days at the Pole to secure sufficient observations to fix the position, Amundsen and his party returned to Framheim in 38 days, picking up the depots in succession and making an average of 23 m. per day in fine weather without any untoward incident. The health of the men and the 11 surviving dogs was perfect throughout the 96 days of the double journey. During the absence of the southern party Lt. K. Prestrud with Frederik H. Johansen and Jørgen Stubberud made a journey to Edward VII. Land with two sledges and 14 dogs. They were absent from Framheim (where Lindström the cook was left in charge) from Nov. 8 to Dec. 16 1911 and reached Scott's Nunatak, which was found to reach a height of 1,700 ft. and was covered with thick moss. The "Fram" returned to the Bay of Whales on Jan. 11 1912 and the whole party sailed for home on Jan. 30, after the shortest and most successful expedition which ever wintered in the Antarctic. The one object, the attainment of the Pole, had been accomplished quickly and easily and the meteorological observations were of great value in extending the conclusions of other investigators.

*Scott (1910-2).*—Capt. Robert F. Scott's expedition, planned with the double purpose of reaching the South Pole and completing the scientific study of the Ross Sea area, reached McMurdo Sound in the "Terra Nova" on Jan. 4 1911 (after seeking in vain for a safe position near Cape Crozier), and erected a commodious wooden house for the main base at Cape Evans on Ross I. about half way between Shackleton's base at Cape Royds and the old "Discovery" headquarters at Hut Point. No polar expedition had been fitted out with greater care for the purpose of scientific research in meteorology, geology, glaciology and biology.

After landing the stores for the main base at Cape Evans the "Terra Nova," under Comm. Harry Pennell, left on Jan. 25 1911, proceeded eastward along the Barrier and, after failing to land on Edward VII. Land, encountered the "Fram" in the Bay of Whales on Feb. 3.

*Scott's Northern Party (1911-2).*—The eastern party decided to return with news of the Norwegian expedition to Cape Evans, and then to proceed as a northern party to some point beyond Cape North, but this also proved unattainable, and a landing had to be made at Cape Adare on Feb. 18 1911. Here a hut was erected and the northern party, under Comm. Victor L. A. Campbell and including Surg. Gen. Murray Levick, Raymond E. Priestley (geologist and meteorologist) petty-officers G. P. Abbott, F. V. Browning and H. Dickason, were landed with stores and sledges but no dogs. One of Borchgrevink's huts built in 1899 was in good order, the other had been unroofed by a storm but both were serviceable. They passed a stormy winter and confirmed Borchgrevink's conclusion that it was impossible to make any extensive journeys either on the sea-ice, which frequently blew out to sea, or by land from this base. On Jan. 4 1912 the "Terra Nova" returned and took off the party, landing them with six weeks' provisions a few days later in Terra Nova Bay, just S. of Mt. Melbourne, on the lower slopes of which much geological work was done. The ship failed to return in Feb. as expected, and the winter of 1912 had to be passed in an ice cave on Inexpressible I. (about lat.  $75^{\circ}$  S.), the party subsisting mainly on seal meat cooked over blubber lamps devised with much ingenuity. This winter, spent almost without stores, was a triumph of adaptability to the hardest possible conditions, and although there was much illness the whole party was able to march when a start for Cape Evans was possible on Sept. 30 1912. The Drygalski glacier tongue was crossed and the party made its way southward along the sea-ice close to shore. On Oct. 28 Granite Harbour was reached and stores left there by Griffith Taylor allowed of full rations of good food for the first time for nine months. The remainder of the 70-m. march to Cape Evans was assisted by several depots, and they all arrived at Hut Point on Nov. 6 1912, after triumphing over the most difficult conditions ever yet surmounted in the Antarctic.

*Scott's Western Party (1911-2).*—During Jan., Feb. and March 1911 Griffith Taylor, with Frank Debenham, Charles S. Wright and P. O. Edgar Evans, made an extensive geological survey and study of the ice phenomenon of the lower valleys of the Western Mountains, from Butter Point southward to the Koettlitz glacier in lat.  $78^{\circ} 20'$  S., and after the winter at Cape Evans, Griffith Taylor made a second western trip with Debenham, Lt. Trygve Gran and P. O. Forde, completing the geological survey of the lower mountain slopes W. of McMurdo Sound from Butter Point northward to Granite Harbour in lat.  $76^{\circ} 50'$  S. This journey lasted from Nov. 1911 to Feb. 1912 and was rich in scientific results.

*Wilson's Winter Journey (1911).*—The finest adventure of the first winter at Cape Evans was the daring journey in solstitial darkness via Hut Point to Cape Crozier and back by Dr. Edward A. Wilson, Lt. H. R. Bowers and Mr. Apsley Cherry-Garrard. It lasted for 36 days from June 27 to Aug. 1 1911, and the total distance traversed by man-hauled sledges was over 100 m., giving an average of about 4 m. per day out and 7 m. a day home. During a stay of ten days an effort was made to study the nesting habits of the emperor penguin. This journey was made in the lowest temperature ever experienced in the Antarctic: many days had readings below  $-60^{\circ}$  F. and the worst was as low as  $-77^{\circ}$  F. The snow in places was as granular and hard to pull through as sand, and only one sledge could be moved at a time, so that on some days many hours' work only made 2 m. in distance.

*Scott's Journey to the South Pole (1911-2).*—The main object of Capt. Scott's expedition being the great southern journey, steps were taken at the earliest date to lay out depots for the main expedition of the following year. The vital point being transport, means had been taken to provide three alternatives to man-baulage. There were landed at Cape Evans 17 Siberian

ponies, 33 Siberian sledge dogs and three motor sledges on the design of which Scott had taken immense pains. The motors were practically useless on account of mechanical defects and were abandoned early in the great march. The health of the animals was a source of unending anxiety and much trouble was experienced in driving them.

The route selected was at first about a day's march to the E. of that taken by Shackleton and consequently far to the E. of that followed by Scott on the "Discovery" expedition, the reason being to get the smooth Barrier ice beyond the influence of the great pressure ridges which disturb the surface near the mountains. But the Plateau was to be reached by Shackleton's way up the Beardmore glacier at which point the tracks converged.

Depots were laid out by Scott in Jan. and Feb. 1911 at Corner Camp in lat. 78° S., Bluff Camp nearly in lat. 79° S. and at One Ton depot which he had hoped to plant in lat. 80° S., but was obliged by circumstances to place in lat. 79° 29' S. only—a necessity which contributed to the greatest Antarctic disaster on record. In Sept. 1911, when the temperature was usually below -40° F., Scott's second-in-command, Lt. Edward R. A. R. Evans, took additional stores to Corner Camp; but no more distant depots were supplemented before the main southern journey started.

The two motor sledges left Cape Evans on Oct. 24 1911, got over the sea-ice to Hut Point, safely ascended to the Barrier and broke down hopelessly, the first a few miles N. of Corner Camp, the second a few miles S. of Corner Camp on Nov. 3. Thenceforward the southern advance was made by 16 people in three parties of four each, reinforced by two from the motor sledges and two with the dogs, one party ahead breaking the trail, the others following at intervals. Bad weather was experienced, frequent blizzards making the advance difficult. Depots with stores were provided for the returning parties at Mount Hooper in lat. 80° 35' S. on Nov. 21 (Day and Hooper of the motor party, who had dragged a sledge so far, left to return three days later), at the Mid Barrier in lat. 81° 35' S., at the South Barrier depot in lat. 82° 47' S. on Dec. 1 and at the entrance to the Beardmore glacier in lat. 83° 30' S. on Dec. 10. The last of the ponies had broken down and been shot, and from this point Meares and the dog-teams returned northward. The party of 12 pushed on up the Beardmore glacier with three man-hauled sledges, and after leaving a depot in the middle of the glacier, reached the Plateau at 8,000 ft. on Dec. 21 1911 and left the Upper Glacier depot in lat. 85° 7' S. Here Dr. Atkinson, Mr. Wright, Mr. Cherry-Garrard and P. O. Keohane returned, and the party of eight went on with two sledges. Ten days later Three Degree depot was formed in lat. 86° 56' S. and at this point Lt. Evans with Crean and Lashley returned. This party was attacked by scurvy as on the southern march from the "Discovery" in 1902, and Lt. Evans broke down on the Barrier and was only rescued by the heroic exertions of his companions. The southern party—now consisting of five men: Scott, E. A. Wilson, H. R. Bowers, L. E. G. Oates and P. O. E. Evans—made one more depot in lat. 88° 29' S. and reached the South Pole on Jan. 18 1912, having made 69 marches averaging over 12 m. per day. His diary shows that in the outward journey Scott's mind was full of care and anxiety, while the disappointment of finding by Amundsen's record that he was not first to reach the Pole was a shock from which his spirits seemed never to recover.

The return journey was commenced without delay, but without any help from animal traction it proved too much for the men. Edgar Evans fell first and after causing fatal delay, he died on Feb. 17 on the Beardmore glacier. Oates, feeling his strength exhausted, had the heroism to sacrifice himself rather than cause further delay, and he left the tent on March 17 in 79° 50' S. never to return. The last camp was made in lat. 79° 40' S., only 11 m. from One Ton depot on March 19, and here during a blizzard which raged for several days Scott, Wilson and Bowers met their fate with heroism, Scott writing to the end. The immediate cause of collapse seems to have been cold, due to the deficiency of oil fuel in the Mount Hooper depot, the reason for which was stated to be evaporation through defective stoppers.

*The Winter of 1912 at Cape Evans.*—During the absence of the southern party the "Terra Nova" had reached Cape Evans in Feb. 1912 and stores were landed, including seven mules from India and 14 dogs. Dr. Atkinson's party, sent back by Scott from the Beardmore glacier, arrived on Jan. 28, and after seeing to matters at the base, Dr. Atkinson went south with the dog-teams in time to rescue Lt. Evans near Corner Camp on Feb. 22, and as the latter was in a serious condition Atkinson stayed with him until he got him on board the "Terra Nova." Cherry-Garrard and Dimitri took the dog-teams back to One Ton depot to meet Scott, reaching that point on March 4 and remaining until March 10 in weather that made a further advance S. impossible, and they got back to Hut Point on the 16th with great difficulty and in a very bad state. The ship left on March 8 to make a final attempt to relieve Campbell's northern party and did not return, so the base party did not know what had happened either to the northern or southern parties. On March 26 Atkinson with P. O. Keohane set out from Hut Point and got as far as Corner Camp, where he turned, being satisfied that Scott's party must have perished. He made one more journey, though it was now very late in the season, and left two weeks' provisions at Butter Point for the northern party, returning to Hut Point on April 23, the day the sun disappeared for the winter. There were 13 souls in the Cape Evans hut that winter, with Dr. Atkinson in charge, Lt. Evans having returned ill to New Zealand and Dr. G. C. Simpson, whose meteorological work had been of unique value, having gone back to his duties in India. On Oct. 30 1912 the whole party, under Dr. Atkinson, with Mr. C. S. Wright as guide, with seven mules and the dogs, set out from Hut Point, and on Nov. 12 the tent with the bodies of Scott, Wilson and Bowers was discovered in lat. 79° 50' S., and the records and collections brought back.

During Dec. 1912 a party of six climbed Mt. Erebus, reaching the summit on the 11th, the second occasion of its ascent.

The "Terra Nova" returned on Jan. 18 1913 and a few days later took off the entire party, reaching New Zealand on Feb. 12. The sensation produced by the tragedy of the expedition was profound and a large fund was subscribed for the benefit of the relatives of the dead explorers and for the promotion of polar research. The scientific results of the expedition have been worked up and are of the highest value in all departments.

*Australian Expedition (1911-4).*—An Australian expedition was fitted out under the command of Dr. (later Sir) Douglas Mawson, with Capt. John King Davis as commander of the ship and second-in-command of the expedition, for the purpose of exploring the coast of Antarctica S. of Australia. The expedition left Hobart in the "Aurora" on Dec. 2 1911, and after landing a party with a wireless installation on Macquarie I. (lat. 55° S.) the ship reached Adelie Land, discovered by D'Urville in 1840, and effected a landing in Commonwealth Bay, the position of which was subsequently fixed by wireless time-signals as lat. 67° S., long. 142° 40' E. Dr. Mawson with 17 companions was landed here in Jan. 1912. The "Aurora" proceeded westward close along the Antarctic circle. Balleny's Sabrina Land, D'Urville's Côte Clarie and most of the land reported by Wilkes were found not to exist, though an enormous ice-tongue which might well have been taken for part of the continent occupied the position of Termination Land. Just beyond this point Mr. Frank Wild was landed on a new coast called Queen Mary Land in lat. 66° S., long. 94° E., and left with seven companions on Feb. 20 1912, the actual position being on a solid ice-shelf about 17 m. from the high land. The "Aurora" returned to Hobart.

At the main base in Adelie Land autumn sledging proved impossible, and throughout the winter there was a continuous succession of terrific blizzards, wind with an average velocity of 50 m.p.h. for the year, and sometimes with average hourly velocity of over 100 m.p.h. poured torrents of drift snow from the interior into the sea. Only the fact that the hut was buried in the snowdrifts saved it from being carried away. No such weather has been recorded from any other part of the world. In the spring two caverns were excavated in the ice at distances

of about 5 and 12 m. respectively from the hut towards the high inland plateau and were stored with provisions for summer sledging; the use of surface depots like those on the Ross Barrier was impossible owing to the wind. Five sledge parties started simultaneously in Nov. 1912, their paths diverging so as to cover the greatest possible area. The eastern sledging parties under Mr. F. L. Stilwell and C. T. Madigan with Dr. A. L. Maclean and others, mapped the coast and huge glacier tongues as far east as long.  $150^{\circ} 20'$  E., reaching the farthest point on Dec. 18. The land, with a surface rising to 3,000 ft. above the sea, extended far to the east and was named George V. Land. It stretched towards Oates Land sighted by the "Terra Nova" of Scott's expedition. Good rock exposures were found containing coal and fossils. The magnetic pole party from the main base, under Lt. R. Bage with E. N. Webb and J. F. Hurley, travelled out 300 m. with man-hauled sledges and reached 6,500 ft. above sea-level at a point only a few miles from that reached by Sir Douglas Mawson and Sir Edgeworth David from McMurdo Sound on Sir Ernest Shackleton's expedition. The western party from the main base under Mr. F. H. Bickerton, with A. J. Hodgeman and Dr. L. A. Whetter, reached a point on the Antarctic circle in long.  $138^{\circ}$  E. on Christmas Day, travelling over the Plateau at a height of about 4,000 ft. An air tractor sledge started with this party but broke down after 10 miles.

Dr. Mawson, with Dr. X. Mertz and Lt. B. E. S. Nimis, using dog sledges, set out for a long journey to the S. E. well inland of Madigan's party, and had very difficult ground to cover, including many rises to over 3,000 ft. with intermediate descents to near sea-level, where there were heavily crevassed glaciers. They had got out about 310 m. to nearly long.  $152^{\circ}$  E. when on Dec. 14 1912 Nimis, with his sledge and dogs, broke through the snow covering of a crevasse of enormous depth and was instantly killed. Many essential parts of the equipment were lost with the sledge, and only six dogs in poor condition were left. From this point the homeward track was laid farther S. than the outward so as to avoid the great ups and downs, and the travellers pushed on in frequent bad weather on short rations supplemented by the flesh of the dogs. Both suffered severely from the insufficient and loathsome food, and Mertz collapsed on Jan. 6 1913 and died the following day, leaving Mawson alone 100 m. from the hut. After three days spent in cutting down the sledge and rearranging its load Mawson started on his lonely tramp, and after appalling difficulties, when nearly exhausted, he stumbled on a food depot laid out by a search party 20 m. from the hut on Jan. 29 1913. It was Feb. 8 when he reached the hut and saw the "Aurora," but she was outward bound. A fresh relief party had come S. in the ship, and a second winter had to be spent in the hut, the isolation somewhat mitigated by wireless intercourse with Australia via Macquarie Island.

Capt. Davis, after landing the relief party and taking off all the others, waited for the return of Mawson as long as he dared, having in view the necessity of relieving Wild's party in Queen Mary Land, and the fact that every anchor on the ship had been lost in the fight with blizzards in Commonwealth Bay. He reached Wild's base just in time, got the party safely on board and returned to Hobart. From their base in long.  $98^{\circ}$  E. Wild's party had travelled W. to the Gaussberg in long.  $89^{\circ}$  E., and E. as far as long.  $101^{\circ}$  E., mapping the glaciers which descended from a plateau rising above 3,000 ft., as well as several islands off the coast. The "Aurora" returned to Commonwealth Bay on Dec. 13 1913, and after taking the base party on board made another voyage to Queen Mary Land and carried out valuable oceanographical work on the way back to Hobart.

*W. Filchner (1911-2).*—Lt. Wilhelm Filchner organized a German expedition to the Weddell Sea in 1911, and sailed from South Georgia in the "Deutschland" (Capt. Vahsel) on Dec. 11 in that year and entered the pack seven days later in lat.  $61^{\circ}$  S. The ship went S. approximately on the meridian of  $30^{\circ}$  W. and sighted land on Jan. 29 1912 in lat.  $76^{\circ}$  S.; about  $2^{\circ}$  S. and  $8^{\circ}$  W. of Bruce's Coasts Land. The "Deutschland" proceeded along the new coast, named Luitpold Land, to lat.  $77^{\circ} 48'$  S., long.  $35^{\circ}$  W. on Feb. 2 1912, where an indentation in the

Barrier ice formed Vahsel Bay, whence the land rose to the S. and three nunataks were observed piercing the snow. Efforts to get farther S. on a westerly course failed, and on Feb. 6 it was decided to erect the winter hut on an iceberg which appeared to be firmly frozen to the Barrier and to offer an easy passage for dog-sledges to the land. All stores were transferred to the iceberg, when on Feb. 18 it suddenly began to move and ponies, dogs, stores and as much of the wood as could be saved were hurriedly reëmbarked. Two small depots of provisions were afterwards laid out on the Barrier ice as a base for land parties while the ship sought for winter quarters; but Capt. Vahsel feared the destruction of the vessel, and induced the leader to change his plans and return to South Georgia for the winter in order to try again next year. The return journey was commenced on March 4 1912, but four days later the ship was beset by young ice in lat.  $74^{\circ}$  S., long.  $31^{\circ}$  W., and remained fast, drifting with the winds and currents of the Weddell Sea all winter, on the whole westward and northward until the middle of August, when she was in lat.  $66^{\circ}$  S. and long.  $44^{\circ}$  W. Thereafter the drift was eastward and northward until she broke out of the pack in lat.  $63^{\circ} 40'$  S. and long.  $36^{\circ}$  W. on Nov. 27 1912 and proceeded for home. The drift lasted for 264 days and no land was sighted, although a sledge journey was made westward to long.  $45^{\circ}$  W. in search of Morrell Land. Capt. Vahsel died during the drift, and the expedition broke up at South Georgia.

*Shackleton's Weddell Sea Party (1914-6).*—Sir Ernest Shackleton had completed his preparations for an attempt to cross the Antarctic regions from Weddell Sea to Ross Sea before the outbreak of the World War, and carried out his expedition at the direct order of the Admiralty, which declined his offer of the ships and men for war service. He left England on Aug. 8 1914 in the "Endurance" and sailed from South Georgia on Dec. 5, with the intention of landing in Vahsel Bay and proceeding thence to the South Pole after wintering on the land. The pack was entered in lat.  $57^{\circ}$  S. and the ship worked her way S. between long.  $15^{\circ}$  and  $20^{\circ}$  W. until on Jan. 11 1915 she sighted Coats Land, and followed new land named the Caird Coast to Luitpold Land. Here the "Endurance" was beset in the ice on Jan. 18 in lat.  $76^{\circ} 34'$  S., long.  $31^{\circ} 30'$  W. and the voyage was at an end. The "Endurance" drifted in the pack as the "Deutschland" had done three years before, and on a nearly parallel track, moving N. about  $10^{\circ}$  farther W. and at almost exactly the same rate in the same latitudes. The ice was however much heavier, and in the terrific pressures which occurred the "Endurance" was crushed on Oct. 27, when the expedition of 28 men with 49 dogs abandoned her and camped on the floe. This was in lat.  $69^{\circ} 5'$  S., long.  $51^{\circ} 30'$  W., and three weeks later the shattered wreck sank through the ice. The attempt to sledge over the ice westward towards the E. coast of Graham Land was unavailing, as the ship's boats could not be left behind and were too heavy to drag. The party therefore camped on the drifting floe, keeping up scientific observations and maintaining their health and spirits though in continual danger from the floes riding up or cracking asunder. The drift went on until April 9 1916 when the floe, reduced to a triangle 100 yds. in the side, drifted into the open sea in lat.  $62^{\circ}$  S., long.  $54^{\circ}$  W., and the party had to take to their boats, after drifting 292 days in the ship and 165 on the bare ice, 457 days in all. North of lat.  $66^{\circ}$  S. the drift of the "Deutschland" had turned sharp to the E., but that of Sir Ernest Shackleton's floe continued in the main due N.; the difference may have been due to the opposite seasons or to other causes. The three boats safely reached Elephant I. in the South Shetlands, and a shelter was rigged up of two boats, where 22 of the party were left under the capable leadership of Mr. Frank Wild, while Shackleton and five companions set out in the third boat, the "James Caird," for the almost desperate attempt to reach South Georgia. The effort succeeded in great measure through the fine seamanship of Capt. Worsley, and the island was reached in 16 days on May 10 after a voyage of over 800 m., but on the side farthest from the whaling stations. After a four-days rest Shackleton, with two companions, had recovered sufficiently to cross the unknown snow-covered mountains, which had never

been climbed before, and a steamer was sent round for the others. Sir Ernest Shackleton made strenuous efforts to rescue the Elephant I. party first in a small steamer from South Georgia, then in a trawler from Montevideo, then in a little motor schooner from Punta Arenas, all of which were driven back by the ice floes near the South Shetlands, and finally in the "Yelcho," a tug from Punta Arenas, in which he reached the island on Aug. 30 1916 and brought back the whole party without a casualty.

*Shackleton's Ross Sea Party (1914-7).*—On the Ross Sea side the "Aurora," under command of Capt. Aeneas Mackintosh, brought an auxiliary expedition to lay out depots on the Barrier to facilitate the latter part of Shackleton's march from the Weddell Sea via the South Pole. The "Aurora" reached Cape Evans on Jan. 16 1915, and, while she remained there with the hope of wintering, Mackintosh and a sledge party laid out depots as far as lat. 80° S. by Feb. 20. This was a better record than in Scott's autumn journey of 1911; but it was midwinter before Mackintosh found the ice strong enough to permit of his return to Cape Evans. Early next summer he started S. again; and was at the 80° depot on Jan. 6 1916 and with five companions reached Mt. Hope at the mouth of the Beardmore glacier in lat. 83° 30' S. on Jan. 20 where he left a depot. The return journey was one of terrible hardship aggravated by scurvy, and the party narrowly escaped Scott's fate. Mr. Spencer Smith died, but the rest reached Hut Point on March 18 1916. In their anxiety to get back to the Cape Evans party, Mackintosh and Hayward attempted the journey on the sea-ice on May 8, but the ice was not strong enough and they were lost. It was July before the rest of the southern party reached Cape Evans.

On May 6 1915 the "Aurora," which had been frozen in and made fast by many cables to the shore at Cape Evans, was blown out to sea with all the ice and was held fast for 315 days, during which time she drifted northward through Ross Sea nearly in the same direction and at nearly the same rate as the "Endurance" was drifting at the same time in the Weddell Sea. She had been severely damaged by ice pressure; but Lt. J. R. Stenhouse, who was in command, rigged a new rudder, and when she was released on March 16 1916 in lat. 68° 27' S., long. 157° 30' E., he brought the disabled vessel safely to New Zealand. The ship was repaired by the New Zealand Government and dispatched under the command of Capt. J. King Davis with Sir Ernest Shackleton on board, and on Jan. 7 1917 she reached Cape Royds and rescued the seven survivors who had come safely through their two winters in spite of shortage of supplies, the winter stores not having all been landed when the ship was blown away. All of the 53 men who returned from the expeditions of the "Endurance" and "Aurora" served in the navy, army or air force during the World War, three being killed and five wounded.

*Scientific Results.*—The scientific results of the expeditions described above could not yet in 1921 be adequately summarized, for the war had retarded the investigation of the collections and the discussion of statistics. It would be impracticable to draw general conclusions as to the physical and biological conditions of the Antarctic regions until the researches of all the expeditions had been published in a comparable form.

All the inferences from earlier work required revision, but specialists of different expeditions had already committed themselves to views which could not be reconciled in the absence of full information from all explorers. This observation applies in particular to the general theory of the meteorology of the South Polar area, as expounded for the Gauss expedition by Prof. Meinardus and for Scott's last expedition by Dr. G. C. Simpson. The results of the Australian and German expeditions, which were for a great part of the time synchronous with those of Scott and Amundsen, required to be taken into consideration before a general theory of the atmospheric circulation within the Antarctic circle could be established. This is also the case as to geology, and the bearings of geological evidence on the probable nature and extent of the Antarctic continent, and the relations of that land mass to the other continents.

See, in addition to the books referred to in the 11th ed., R. Amundsen, *The South Pole* (two vols. 1912); L. Huxley, *Scott's Last Expedi-*

*tion* (two vols. 1913); R. E. Priestley, *Antarctic Adventure, Scott's Northern Party* (1914); G. Taylor, *With Scott, the Silver Lining* (1916); Sir D. Mawson, *The Home of the Blizzard* (two vols. 1915); J. K. Davis, *With the "Aurora" in the Antarctic* (1920); Sir E. Shackleton, *South* (1919). (H. R. M.)

**ANTHROPOLOGY.**—The earlier article (*see* 2.108), discussing the problem of man's origin and the possibility of recovering fossils which would throw further light on early types of man, included the remarkable statement:—"It seems as if anthropology had in this direction reached the limits of its discoveries" (*see* 2.116). This prediction has fortunately been justified almost every year since it was made, for later years have yielded an abundantly rich harvest of anthropological data and a clearer vision of their significance. In fact they have witnessed a profound revolution in every branch of the study of man. New and important information has been acquired concerning man's ancestry, and the factors that brought the Primates into existence and transformed one branch of the Order into the human family. Hitherto unknown types of fossil men have been found in the Mauers Sands near Heidelberg, at Pliedown in Sussex, at Taigai in Queensland, at Wadjak in Java and at Boskop in the Transvaal. So many examples of Neanderthal Man have been found at Le Moustier, La Chapelle-aux-Saints, La Quina, La Ferrassie, in Jersey and near Weimar, that we are now able to get a very clear idea of the appearance and distinctive features of the brutal species of man that preceded *Homo sapiens* in Europe. Much new information has been acquired of the different races of *Homo sapiens* that made their way into western Europe after *Homo neanderthalensis* disappeared from the scene; and the discovery of their paintings on the walls of caverns in southern France and in Spain and their plastic art has been an astounding revelation of the genius and skill no less than the artistic feeling of these earliest known members of the species to which we, and all men now living, belong.

The brilliant researches of French anthropologists have made it possible to classify the phases of culture of the so-called upper palaeolithic age and assign to each its distinctive features and its chronological sequence with reference to the other phases. Intensive studies of the older civilizations of Egypt, Elam, Sumer (and Babylonia, which succeeded it), Crete, the Aegæan, Palestine, Syria and Asia Minor, have made it possible to understand the origin of civilization in a way that was undreamt of hitherto; and it is now possible confidently to sketch out the process whereby this common civilization was diffused into Europe, to Turkestan and India, to Siberia and China, to Indonesia and Oceania, until finally it crossed the Pacific to Central America and Peru. But perhaps the most profound change that was initiated in anthropology during the decade 1910-20 was the demolition of many of the dogmas which for half a century had paralyzed ethnological investigation and prevented those who were collecting the evidence from appreciating its real significance. This fundamental change of view had not in 1921 been generally accepted by ethnologists, but there were already then very obvious signs that many of them were preparing to repudiate the fashionable doctrine, which had been expressed in its most extreme form in the earlier article in this Encyclopaedia.

*The Evolution of Man.*—In spite of not infrequent attempts to disprove man's kinship with the apes, recent research in anatomy, embryology and comparative pathology, as well as the conclusive tests of blood-relationship, has definitely established the fact of man's close kinship with the anthropoid apes, and especially with the gorilla. But this fundamental conclusion is not in any sense invalidated by the clear recognition of the further fact that the ancestors of man and the gorilla respectively became differentiated the one from the other at least as early as the middle of the Miocene period. This does not mean that man's forebears assumed their human characteristics at the period mentioned, but rather that the ancestors of the gorillas and chimpanzees had begun to assume their distinctive specializations and to fall out of the race for intellectual supremacy which was eventually to be attained by the descendants of their unspecialized Miocene brothers. It is in the highest degree



probable that throughout the Miocene, man's ancestors were still simian. All we know of them is that certain fossil apes found by Dr. Pilgrim in the foothills of the Himalayas reveal curious little peculiarities of structure that serve to identify them in his opinion as members of the group of anthropoids from which the *Hominidae* were eventually derived—probably not until the latter part of the Pliocene (G. E. Pilgrim, "New Siwalik Primates," *Records of the Geological Survey of India*, xlv., 1915). But whether or not Dr. Pilgrim is justified in his claim that the newly discovered Miocene ape which he has called *Sinapithecus* is the ancestor of man or not, it is quite certain that in Miocene times the region of the Siwalik Hills was a great breeding-ground of anthropoid apes, and that the great variety of species and genera which were evolved there included the ancestors not only of the orangs, the chimpanzees and gorillas, but also of the human family. The ancestors of the chimpanzees and gorillas spread west with man's forerunners and reached not only Africa, where their descendants have survived until the present day, but also Europe where the fossilized remains of *Dryopithecus* are widespread. In the course of its wanderings between northern India and Africa human characteristics emerged in one of these simian forms.

The outstanding difference between the earliest member of the human family and his simian cousin was the fact that his brain had developed a little further than the ape's, so that he was able to learn to perform acts of a higher degree of skill not only with his hands but with his vocal muscles. He had acquired the power not merely of a fuller appreciation of the symbolism of sound, but also of arbitrarily imitating sounds and of creating a vocal symbolism whereby he could learn from his fellows and communicate his ideas to them. It was the enormously enhanced power of acquiring knowledge and profiting from the experience of his fellows that differentiated man from the apes; and the peculiar features of the endocranial casts of the fossils *Pithecanthropus* and *Eoanthropus* suggest that the acquisition of the power of speech may have been an essential part of the process of making a man from an ape.

If India has provided us with new light on the place and time of the separation of man's ancestors from the other apes, Egypt has revealed the origin of the anthropoids. It was in 1901 that Dr. C. W. Andrews, of the British Museum, discovered that the Egyptian Fayum was a veritable museum of hitherto unknown fossil ancestors of several mammalian Orders. His prediction that important monkeys would be found there has been fully realized by the discovery of the very primitive Catarrhine *Parapithecus* and an anthropoid ape, *Propliopithecus* (M. Schlosser, "Beiträge zur Kenntnis der Oligozänen Landsäugetiere aus dem Fayum [Aegypten]," *Beitrag zur Pal. u. Geol. Österreich-Ungarns u. d. Orients*, Bd. xxiv., 1911). The discovery of a diminutive anthropoid as early as the beginning of the Oligocene period prepares us for the fact that it presents many signs of not distant kinship with the peculiar Eocene Tarsioides, a Sub-Order of Prosimiac, one of whose members, the Spectral Tarsier, still survives to-day in the forests of Borneo, Java and certain other islands of the Malay Archipelago. For some years intensive studies have been made of the anatomy and embryology of this remarkable creature (see, for example, "the Discussion of the Zoological Position and Affinities of Tarsius," *Proc. Zool. Soc. London*, 1919, published Feb. 1920); and these investigations have shed a great deal of light upon the factors that brought the Primates into being and in one group of the Order initiated further changes, especially in the cultivation of stereoscopic vision and all that it entailed in the stimulation of brain-growth, which ultimately culminated in the emergence of human powers of foresight and discrimination (see *Presidential Address to the Anthropological Section of the British Association*, 1912).

*Fossil Remains of Extinct Members of the Human Family.*—The conclusion to which the study of man's ancestry had led investigators, that the brain led the way in the emergence of human characters, received a dramatic confirmation in 1912, when the late Mr. Charles Dawson and Dr. Smith Woodward announced that the former had discovered (in a patch of gravel

alongside the path leading to Barkham Manor, the residence of Mr. Charles Kenward, near Piltown in Sussex) fossilized fragments of the skull of a palaeolithic member of the human family quite unlike anything known hitherto (C. Dawson and A. Smith Woodward, "On the Discovery of a Palaeolithic Skull and Mandible in a Flint-bearing Gravel overlying the Wealden (Hastings Beds) at Piltown, Fletching (Sussex)," *Quarterly Journal of the Geological Society*, vol. lxx. (1913) and vol. lxx. (1914); the best photographs of these highly significant specimens will be found in *A Guide to the Fossil Remains of Man in the Department of Geology and Palaeontology in the British Museum*, first issued in 1915). Sufficient of the cranium was recovered to restore the whole of the brain case; and it is important to remember that, although a lively altercation was provoked in 1913 as to the proper way of reconstructing the skull, there never was any real doubt as to the form of the brain case on the part of those who were studying the actual fossils, because these display the anatomical details which leave no room for any doubt on the points at issue. The interesting feature of the cast of the interior of the cranium is the demonstration it affords that this extremely primitive "Dawn Man," *Eoanthropus Dawsoni*, as Dr. Smith Woodward has called him; had a brain which fell definitely within the range (so far as size is concerned) of variation of modern men's brains. But it displayed some remarkable deficiencies, more especially in the singularly poor development of those frontal, parietal and temporal areas, the noteworthy expansion of which is the fundamental distinctive character of the human brain. Perhaps the most interesting feature of the endocranial cast of the Piltown man is the remarkable localized overgrowth of that particular part of the brain (the posterior part of the superior temporal convolution) which in modern man is intimately associated with the appreciation of the acoustic symbolism of speech. As a somewhat analogous boss is found on the endocranial cast of *Pithecanthropus*, the fossilized remains of which were found nearly thirty years ago in Java by Dr. Eugen Dubois, it affords grounds for the view that the acquisition of speech may have been one of the essential elements in the transformation of an ape into a man.

It is of fundamental importance to realize that, in spite of its size, the endocranial cast of *Eoanthropus* reveals these indubitable traits of an extremely early phase in the attainment of human characters; and the brain was contained in a skull of a peculiarly distinctive type. For so simian is the form of the jaw that many anatomists and palaeontologists refuse to admit that it is human, and claim that a hitherto unknown chimpanzee expired at Piltown in Pleistocene times on the same spot as *Eoanthropus* and that the former left its jaw and the latter its skull. This view is widely held, but chiefly by non-British anatomists (see, for example, M. Ramström, "Der Piltown Fund," *Geol. Inst. of Upsala*, vol. xvi., 1910) who have never studied the actual fossils. Had they done so they would have realized that, in spite of its form, both the mandible itself and the teeth lodged in it display undoubted human characters. Moreover the cranium also reveals much more primitive features than is commonly supposed by those who have not seen and handled it. In fact there is no reason for withholding assent to the view that this remarkable cranium, which formerly lodged a brain of extremely primitive character, once formed part of the same individual whose jaw had not yet lost all the marks of the ape.

A vast amount of writing has accumulated since 1912 with reference to this remarkable skull, but most of this literature is irrelevant and misleading, as the authors have not seen the material about which they write and have no adequate realization of the true state of affairs.

As to the age of the Piltown skull, precise information is lacking. It was found in an ancient river bed along with rolled teeth of Pliocene elephants and rhinoceros that had been washed out of some older geological formation, and unrolled teeth of early Pleistocene hippopotamus and beaver and the base of the antler of a red deer. From a consideration of all the evidence it

is reasonable to assume that the Pittdown man lived in the early Pleistocene period, and this inference is borne out by the crude implements of flint and elephant-bone found along with the skull. The crucial importance of *Eoanthropus* depends upon the fact that it is so obviously close to the main line of descent of modern man. Yet it reveals such astounding simian resemblances that many—perhaps the majority of—recent writers want to claim its jaw as a chimpanzee's. This in itself is a striking demonstration of the closeness of the affinity of primitive man and certain apes.

Although in 1921 it was nearly thirty years since Professor Eugen Dubois discovered at Trinil, on the banks of the Solo river in Java, the fossil which he regards as parts of one individual, *Pithecanthropus erectus*, his monograph on the subject had not been published. Nevertheless the stream of writings on this ape-man was still flowing unabated. In Boule's *Les Hommes Fossiles* (1921) the distinguished French palaeontologist still maintained that *Pithecanthropus* is not a member of the human family, but is an ape. Dubois himself maintains that it is neither a man nor an ape, but a creature really intermediate between them. But the endocranial cast of *Pithecanthropus* reveals the fact quite definitely and surely that as regards size, shape and the relative proportion of parts, this so-called ape-man of Java comes within the range of the *Hominidae*. Moreover, as has already been mentioned, its endocranial cast exhibits a fullness of the postero-superior part of the temporal area which suggests the acquisition of the characteristically human power of speech. The question is still debated whether the thigh-bone found in the same bed as the skull-cap of *Pithecanthropus* really belonged to the same individual. It is so obtrusively human that some authorities find a difficulty in associating it with the skull: but the balance of evidence is in favour of both being parts of one individual, the most primitive and the earliest known member of the human family, aberrant both in physical type and habitat. Controversy was still proceeding in 1921 as to the age of the *Pithecanthropus* remains, and new evidence provided by the Selenka expedition has been used to strengthen the hands of those who object to the claim of Dubois that the remains belong to the Upper Pliocene and maintain that these earliest known representatives of the human family are to be referred definitely to the commencement of the Pleistocene period (Selenka and Blanckenhorn, "Die Pithecanthropus-Schichten auf Java," *Geologische und palaeontologische Ergebnisse der Trinil-Expedition*, Leipzig, 1917).

In 1905 the remains of *Pithecanthropus* represented the only known member of the family *Hominidae* which did not belong to the genus *Homo*. Since then, however, the remains of other forms have been revealed that surely deserve generic distinction. In 1907 a human lower jaw was found in the base of the Maues Sands near Heidelberg, which was described by Schoetensack as a hitherto unknown member of the human family which he called *Homo heidelbergensis*. But its age and peculiar features remove it so far from all the members of the genus *Homo* that it is more in accordance with the proper perspective to follow Bonarelli who has created for its reception the genus *Palaeoanthropus*. It is extremely massive and is unlike any other human jaw, not merely by reason of its size but also in the ape-like recession of its chin.

*Neanderthal Man*.—The fossilized remains of part of a cranium and some long bones found in 1856 by some workmen in the Feldhofer Grotto in the Neanderthal Valley (between Elberfeld and Düsseldorf in Rhenish Prussia) are now generally admitted to represent a species of the genus *Homo* that is definitely differentiated from the species *sapiens*, to which all the living races of man belong. This extinct species is known as *H. neanderthalensis*, a name first suggested in 1864 by Prof. King of Galway. In 1848 a fossil skull was found at Gibraltar by Lt. Flint, but no attention was devoted to it until Busk described it in 1864; and it is now commonly supposed to be a female of the Neanderthal species; but Sera (*Soc. romana di Anrop.*, xv, 1909) considers it to be more primitive and earlier than the true Neanderthal people. Other examples of the Neanderthal species

have been found in the grotto of Spy (Belgium) in 1886, at Krapina (Croatia) in 1899, at La Chapelle-aux-Saints (La Corrèze, France) in 1908, Le Moustier in the Dordogne (1909) and in the same year at La Ferrassie in the same region. Another skull was found in the same region in 1910, and in 1911 yet another at La Quina (Charente). To this remarkable series of skeletons found in France, which give us so complete a picture of the distinctive features of this brutal extinct species of our genus, is to be added fragments of two jaws found in 1914 at Ehringsdorf near Weimar in Germany (see Hans Virchow, *Die menschlichen Schädelreste aus dem Kämpfischen Bruch im Traverin von Ehringsdorf bei Weimar*, Jena, 1920). The vast literature that has accumulated with reference to the other examples of *Homo neanderthalensis* will be found summarized in M. Boule's *Les Hommes Fossiles* (Paris, 1921) as well as in H. F. Osborn's *Men of the Old Stone Age* (New York, 1915) and W. J. Sollas's *Ancient Hunters and their Modern Representatives* (London, 2nd ed. 1914).

Neanderthal man is now revealed as an uncouth race with an enormous flattened head, very prominent eye-brow ridges and a coarse face. The trunk is short and thick, the robust limbs are short and thick-set: the broad and stooping shoulders lead by a curve to the forwardly projected head set on an abnormally thick neck. The hands are large and coarse and lack the delicate play between thumb and fingers which is found in *Homo sapiens*. The large brain is singularly defective in the frontal region. It is clear that Neanderthal man's limbs and brain were incapable of performing those delicately skilled movements that are the distinct prerogative of *H. sapiens* and the chief means whereby the latter has learned by experiment to understand the world around him, and to acquire the high powers of discrimination that enabled him to compete successfully with the brutal strength of the Neanderthal species.

The Neanderthal race of men, with their distinctive Mousterian culture, suddenly disappeared from Europe, and were replaced by immigrants belonging to our own species, who brought with them to Europe the germs of the phase of culture known as Aurignacian. These newcomers were members of the Cro-Magnon race, a very tall people with large dolichocephalic skulls and relatively broad face. They probably entered Europe from the S., because their settlements are found chiefly near the Mediterranean coastline, in northern Africa, Sicily, Italy, southern France and Spain. The coming of this superior race of highly intelligent men is revealed also by the sudden improvement in the technique of the flint-work and the appearance, especially in the caves of southern France, of mural paintings revealing new powers of artistic observation and skill in depicting the animals which these people hunted. There is revealed for the first time the genius and the aesthetic feeling of members of our own race. At a later period the members of another race (also dolichocephalic, but with much narrower and more harmonic face than the Cro-Magnon people) began to make their way into Europe from the East, probably by way of Poland and Moravia, Hungary and Bavaria, thence into France. These people are often known as the Brunn race and their culture as Solutrian. The skeletons are found deeply imbedded in loess along with the bones of the woolly mammoth, woolly rhinoceros, giant deer, reindeer, etc. Their culture is distinguished by the wonderful skill in flaking flint implements. Although it lasted only a short time in Europe and never extended as far as Spain or the Mediterranean area, this method of stone-working spread far and wide, to Egypt, Australia and America, and in the latter two countries persisted until the present time.

After the Solutrian came the Magdalenian phase of culture, which marked the culmination of the skill and achievement of man before agriculture. This new development was not derived from the Solutrian art, but was brought into Europe and replaced the latter. It lacked the superb skill of the Solutrian flint-workers, but was characterized by a high degree of ability in painting and sculpture.

For information concerning the culture of the Magdalenian epoch in France and Spain see Gabon's *Men of the Old Stone Age*; also the

books by Déchelette, *Manuel d'archéologie préhistorique, celtique et gallo-romaine*, Paris, 1910-13 and Sollas, *Ancient Hunters and Their Modern Representatives*.

The Magdalenian phase of culture in western Europe was succeeded by the Neolithic, a momentous event, which was heralded by the arrival in different parts of Europe of a variety of races—(a) an advance wave of the Mediterranean race which was soon to introduce the distinctive elements of the Neolithic culture, but at first introduced the Azilian-Tardenoisian industry into Spain and France; (b) another offshoot of the Mediterranean race that made its way to Ofnet in Eastern Bavaria; (c) a race possibly of Nordic affinities that appeared on the coasts of the Baltic, but is known only by the Maglemose industry; and (d) a broad-headed advance guard of the so-called Alpine or Armenoid race (distinguished as Furfooz-Grenelle) found along with the dolichocephalic people at Ofnet and also in Belgium.

The coming of the Neolithic people into western Europe marks the advent there of people who brought the rudiments of the great world civilization that was being built up in the Ancient East. For the cultivation of barley and wheat, the making of pottery, the weaving of linen and several other distinctive features of the Neolithic phase of culture are clearly instances of customs which had their origin in Egypt or its neighbourhood at a time when western Europe was still in the so-called "Upper Palaeolithic" phase. Towards the end of the Neolithic phase in the W., when megalithic monuments make their appearance as crude imitation of the stonework of the Pyramid Age in Egypt ("The Evolution of the Rock-Cut Tomb and the Dolmen," *Essays and Studies presented to William Ridgeway*, 1913), we get even more definite indications of the source and date of the cultural inspiration to build such peculiar and distinctive structures; and the close identity of their geographical distribution with those of the ancient exploitation of flint, gold, copper, tin, pearls, jet, amber and purple indicates clearly enough the motives that attracted the culture-bearers to certain localities and made them *foes* of new developments of culture (W. J. Perry). It is important to remember that in the home of their invention the working of gold and copper preceded the building of stone monuments by some centuries; but as prospectors searched for gold and copper ores they invaded territories and obtained these materials from them long before the metals themselves were worked or used locally, *i.e.* while the latter still remained in the stone phase of culture. These are very cogent reasons for the belief that the working of copper first began in Upper Egypt or Nubia (Reisner, quoted by Elliot Smith, *The Ancient Egyptians*, chap. 1; see also *Man*, Feb. 1916, p. 26) and from there spread to Palestine and Syria, to Elam and Asia Minor, Cyprus and the Aegean. It is probable that the making of bronze was first devised early in the third millennium in the neighbourhood of the south-eastern corner of the Caspian, perhaps near Meshed, and from there the practice spread W. and S., and later E., until not only western Asia and Europe passed into a Bronze Age, but also eastern Asia and Central and S. America.

*The Talgai and Wadjak Skulls.*—At the meeting of the British Association in Sydney in 1914 Profs. J. T. Wilson and T. W. Edgeworth David exhibited the fossilized skull of a boy of about fifteen years of age, which had been picked up thirty years before in Queensland. A full account of this skull was published in 1918 (Stewart Arthur Smith, "The Fossil Human Skull found at Talgai, Queensland," *Philosophical Transactions of the Royal Society*, B, vol. ccviii.). The interest of this earliest Australian skull lies in the fact that it conforms so closely to the type of the existing aboriginal Australian, its only peculiarity being the exceptional size of the palate and teeth, and especially of the large and salient canine teeth. The discovery of fossilized dog's teeth in the cave breccias of New South Wales and Victoria go to prove that early man accompanied by his dogs must have ferried across Wallace's line to make his way into New Guinea and Australia.

The publication of the account of this proto-Australian skull stimulated Prof. Eugen Dubois to announce the information

that thirty years earlier he had found fossilized remains of members of the same race at Wadjak in Java ("De proto-Australische fossiele Mensch van Wadjak, Java," *Koninklijke Akademie van Wetenschappen te Amsterdam*, Deel, cxix., May 29 1920).

*Boskop Skull.*—About the same time that the discovery of the Talgai skull was announced in Australia the discovery was recorded of a very different type of fossilized skull from Boskop in the Transvaal (S. H. Haughton, "Preliminary Note on the Ancient Skull Remains from the Transvaal," *Transactions of the Royal Society of South Africa*, vol. vi., 1917). The fossils consist of part of the brain case and jaw of a type of man differing profoundly from the earliest known inhabitants of S. Africa, the Bushman and the Hottentot. They represent the remains of a variety of *Homo sapiens* in some respects akin to the Cro-Magnon race, the earliest type of *Homo sapiens* known in Europe.

*Oldoway Skull.*—In 1914 also the fossilized remains of a human skeleton were found in Central Africa (H. Reck, "Erste vorläufige Mitteilung über den Fund eines fossilen Menschen-skeletts aus Zentralafrika," *Sitzungsberichte der Gesellschaft naturforschender Freunde zu Berlin*, 1914), but adequate information concerning this discovery is still lacking.

*Early Man in America.*—Although it is certain that at a relatively early period in the history of *Homo sapiens* there must have been an immigration (by the Bering Strait route into N.W. America) of people sprung mainly from the proto-Mongolian stock, living E. of the head-waters of the Yenisei river, no remains of really early man in America have yet been discovered. The mere finding of implements of Palaeolithic types proves little, because the making of such implements has survived in the East, and the art may have been carried to America within relatively recent times. Up to 1921, the most recent discovery of human remains supposed to be early was made at Vero in Florida in 1916, but the geological evidence showed that the fossilization had occurred in post-Pleistocene times. There is, however, still great uncertainty as to the age of these remains, which do not differ in type from many modern American Indians.

The whole problem of early man in America has been explored in a severely critical spirit by Dr. Ales Hrdlicka, who gives a full bibliography ("Skeletal Remains suggesting or attributed to Early Man in N. America," *Smithsonian Institution, Bureau of American Ethnology, Bull.* 33, Washington, 1907; "Early Man in S. America," *ibid.*, 1912; and "Recent Discoveries attributed to Early Man in America," *ibid.*, 1918).

It is probable that the substratum of the early population of America consisted of a colony of a proto-Mongolian race mixed perhaps to some extent with proto-Armenoid elements in the original Siberian homeland. In later ages, more especially between about 300 B.C. and 1000 A.D., this population in America has been very considerably diluted—more especially on the Pacific coast—by a steady percolation of a variety of alien elements into the N.W. coast from Asia and into Central and South America from Polynesia and Micronesia in numbers sufficient materially to affect the physical type of the people of the western littoral and differentiate them from the eastern people.

For the evidence in support of this (but with a different interpretation) see Clark Wissler, *The American Indians* (New York, 1917). Dr. Wissler's book is also an invaluable summary of the present state of our knowledge of the geographical distribution of the arts and crafts of America, and a striking demonstration of the fact that the arts of agriculture, pottery, weaving, stone-working, metallurgy, etc., were diffused abroad in America from one centre somewhere in the region of Honduras. But he stoutly denies the conclusion (which emerges so clearly from the evidence he presents) that the elements of this exotic culture were planted in Central America by small groups of immigrants who had crossed the Pacific Ocean via Polynesia from Cambodia and Indonesia.

*Classification of Existing Races.*—Between 1910-20 it became increasingly clear that the generally adopted classification of mankind and of early culture was unsatisfactory, and not in full accordance with the facts that are now available. The introduction of the terms "Palaeolithic" and "Neolithic" by Sir

John Lubbock (afterwards Lord Avebury) served a useful purpose for a time in discriminating between the early and the later methods of flint-working before the discovery of bronze. But it is now known that the great break in the technique of stone-working did not occur at the transition from the Palaeolithic to the Neolithic phase, but when the so-called "Lower Palaeolithic" gave place to the so-called "Upper Palaeolithic."

The vast significance of this great revolution in man's history (at any rate in western Europe) is emphasized by the fact that it coincided with the final disappearance of the species *H. neanderthalensis* and the coming of the members of the species to which we ourselves (and all existing members of the human family) belong, *i.e.* *H. sapiens*. The replacement of the degraded type of mankind with his crude Mousterian culture and the coming of *H. sapiens* with his greater skill and artistic aptitude is surely the most significant revolution in the whole of man's history. To discriminate between these two phases of culture, Elliot Smith has suggested the terms, "palaeanthropic" and "neanthropic" to apply respectively to the extinct species and their works and *H. sapiens* and his achievements ("Primitive Man," *Proceedings of the British Academy*, 1917).

All the races of man that exist at present belong to the species *sapiens*, but they differ profoundly in type and in the probable dates of their differentiation the one from the other. The most primitive race of all is the aboriginal Australian, who represents the survival of the earliest phase of *H. sapiens* with relatively slight change. After he separated from the rest of mankind he found a home in India, where he formed the substratum of the aboriginal people called pre-Dravidian. The rest of this race wandered E. until they reached Australia, small remnants remaining in some of the Indonesian Is. as abiding witnesses of the ancient migration. Probably at a much later period the Negro and Negrito became differentiated from the rest of mankind and found their area of characterization in tropical Africa, from which place in later times negroid peoples drifted along the whole southern littoral of Asia to Indonesia and Melanesia. It is probable that the Bushmen and Hottentot races represent early differentiations from the Negro stock. These two races, Australian and Negro, retain the black colour of skin which originally was probably common to all mankind and his nearest relatives, the gorilla and chimpanzee. After the Australian and Negro had been differentiated the rest of the human family attained a higher plane of development associated with a bleaching of the skin, a refinement of the features and a further growth and specialization of the brain. This palaeo-facial stock became broken up during the glacial period into four main stocks which became isolated the one from the other. Probably the earliest to wander off and become segregated—possibly in the region of the Yellow river—was the proto-Mongolian group which in course of time became specialized in structure as the Mongolian race. The next group probably found its area of characterization in N.E. Africa where it assumed the less specialized, *i.e.* relatively primitive, features that distinguish the Brown or Mediterranean race. Two other groups became isolated in the N.—one, probably in Turkestan, assumed brachycephalic traits and developed into the so-called Alpine or Armenoid race; the other, somewhere to the N.W., retained its primitive dolichocephaly but developed the distinctively blond traits that are the obtrusive characteristic of the Nordic race. Within each of the areas of characterization groups became isolated and differentiated in greater or less degree the one from the other. Moreover at the end of the glacial period, when the great ice-barriers disappeared there was extensive intermingling not merely of the formerly isolated groups of the same race, but also of different races. In Siberia especially there was a complex intermixture of Armenoid, Mongolian and Nordic peoples; and in western Asia and the Mediterranean littoral a variety of blends of Brown and Armenoid peoples. It was probably after a certain amount of such intermixture had occurred near the head-waters of the Yenisei that an essentially proto-Mongolian people moved E. and crossed into America as the first inhabitants of the New World.

The whole racial problem was in 1921 still in process of reconsideration. The best collection of facts relating to the subject will be found in the new edition of Keane's *Man, Past and Present*, edited by Quiggin and Haddon (Cambridge, 1920), but the headings of the chapters preserve the fallacies of the effete system of classification that is now being discarded.

Only the most inveterate prejudice can blind one to the fact that the widespread movement of small groups of people in Polynesia (the chief ingredients in whose constitution were elements of the Brown and Armenoid races) served to link up America with the Old World, and to provide the means whereby the elements of the early civilization of south-eastern Asia were introduced into Central America and Peru. No ethnologist doubts for a moment that the early mariners reached Easter I., because the island is peopled, and the language and the culture of the islanders afford proof of the fact that they came from the West. But it must be apparent that for every ship that chanced to strike that microscopic islet in eastern Polynesia there must have been hundreds, if not thousands, that missed it and were swept on to the coast of America. The whole culture of this Pacific littoral affords corroborative evidence of the fact that these early mariners did plant in Central America and Peru the beliefs and customs which we know them to have had. Mr. Charles Hedley claims (*Man*, Jan. 1917, p. 12) that the peoples of Oceania obtained from America the coconut and the sweet-potato as the result of such intercourse. The recent discovery (Chinnery) of the use of tobacco in the central highlands of New Guinea raises the question whether America learned the use of tobacco from Papua or the reverse. The very primitive and peculiar methods of smoking tobacco that Lt. Chinnery discovered in New Guinea suggest that if introduced from the East it must have occurred at a relatively remote period.

*The Diffusion of Culture.*—For half a century ethnology has been suffering from a grave reaction which it is only now beginning to overcome. Thus in the earlier article it was stated (see 2.119)—

"Anthropological researches undertaken all over the globe have shown the necessity of abandoning the old theory that a similarity of customs and superstitions, of arts and crafts, justifies the assumption of a remote relationship, if not an identity of origin, between races. It is now certain that there has ever been an inherent tendency in man, allowing for difference of climate and material surroundings, to develop culture by the same stages and in the same way. American man, for example, need not necessarily owe the minutest portion of his mental, religious, social or industrial development to remote contact with Asia or Europe, though he were proved to possess identical usages. An example in point is that of pyramid-building. No ethnical relationship can ever have existed between the Aztecs and the Egyptians; yet each race developed the idea of the pyramid tomb through that psychological similarity which is as much a characteristic of the species man as is his physique."

This once authoritative statement is cited at length to call attention to the actual teaching in ethnology which went far to sterilize half a century's intensive investigation; and as the present tendency is to sweep away all such sophistry and introduce into ethnology the real scientific method, it will be useful to examine the claims of the system which has to be got rid of.

Let us take the above five sentences as quoted *seriatim*. As it stands the first sentence would be altogether satisfactory if it really meant that ethnology utterly and totally disclaimed the view that similarity of customs implied racial kinship. The fact that a Japanese makes a steam-engine does not transform him into an Englishman! But as the second sentence shows, the ethnologists were confusing race and culture. The Japanese engineer who builds the steam-engine does not do so because there is "an inherent tendency in man to develop culture in the same way": the fact that the making of a steam-engine does not transform him into an Englishman does not preclude the recognition of the debt he owes directly or indirectly to Englishmen for the idea and for the methods of putting it into practice. Instead of it being "now certain" that there is "an inherent tendency in man" (in other words what the psychologist calls an instinct) to build steam-engines or pyramids, both the facts of history and the principles of psychology teach us that there

is no such specialized instinct. With reference to the protest that American man did not borrow mental, religious, social and industrial ideas from Asia, no one has provided more cogent illustrations of the fact that he did do so than the author of the disclaimer himself (see, for example, "On the Diffusion of Mythical Beliefs as Evidence in the History of Culture," *Report British Association*, 1894, p. 774; "On the Game of Patolli," *Journal Anthropological Institute*, vol. viii., 1879, p. 128). The series of step-pyramids that are scattered from Mesopotamia to Ceylon, to Cambodia and Java, to Japan and Shantung, to Tahiti and the Marquesses, to Peru and Mexico afford so striking a demonstration, not only of the spread of a very definite and peculiar phase of culture, but also of the route of the diffusion that many of the reactionary school in ethnology have felt it incumbent on them to get rid of evidence that was so awkward and obtrusive.

It was formerly claimed in effect that man had a pyramid-building instinct, which presumably was kept in check by the vast majority of mankind, but burst its bounds in a chronological sequence among the peoples scattered along the coasts from Egypt to Central America. The more fully the details of these pyramids are studied the more complete is the demonstration of their derivation one from the other as the stream of culture moved from West to East. In Ceylon at Polonnaruwa we find pyramids of Mesopotamian design but built of stone like those of the Egyptians. The less ornate Khmer pyramids, such as Ka-Keo and Ba-Kong, of Cambodia, reproduce the Sinhalese models with singular accuracy: and then pyramids of the same type appear in western Peru and Equador, Central America and Mexico, the Mississippi Valley and the south-eastern region of the United States, the transference of the incentive across the Pacific having been effected probably between the third and the tenth centuries A.D.

The acceptance of ideas concerning the possibility of spontaneous generation—with curious lack of knowledge and logic the ethnologists called it "evolution"—of similar ideas and customs among widely distant peoples was paralyzing the study of ethnology and removing it farther and farther from the stimulating influence of serious discussion and honest observation. Dr. W. H. R. Rivers was mainly responsible for leading ethnology out of this morass. In his presidential address to the Anthropological Section of the British Association in 1911 he exposed the fallacies of the popular ethnological doctrine and insisted on the importance of the diffusion of culture. One of the fallacies that had led ethnologists astray and facilitated the acceptance of the weird speculation of spontaneous generation of culture was the belief that useful arts could not be lost. One finds this view expressed in the earlier article (see 2.117):—

"Had the Australians or New Zealanders, for instance, ever possessed the potter's art, they could hardly have forgotten it."

By demonstrating the fallacy of this argument and showing that even so vital an art as boat-building could be lost by an island people, Dr. Rivers (*Report British Association*, 1912, p. 598; also *Festschrift Tilgnaad Edvard Westermarck*, Helsingfors, 1912, p. 109) removed the only serious obstacle in the way of the acceptance of the truth of the diffusion of knowledge in the way we know it to have been spread abroad in historical times.

From a detailed study of the technique of embalming Elliot Smith became convinced that the evidence provided by mummies from the islands in Torres Strait was so conclusive a proof of the influence of Egypt as to leave no possibility of doubt as to the certainty of the spread of culture from Egypt to New Guinea and Australia; and as the result of an examination of methods of mummification in various parts of the world he put forward a theory of *The Migration of Early Culture* (Manchester, 1915), in which the evidence provided by the geographical distribution of megalithic monuments, sun-worship, ear-piercing, tattooing, couvade, artificial deformation of the head, the use of the swastika, etc., was used to corroborate the reality of the diffusion of the ingredients of early civilization. If, as this theory claimed, the spread of culture took place in large measure by sea ("Ancient Mariners," *Journal of the Manchester Geographical Society*,

1917), the Indonesian archipelago ought to preserve some evidence of the movement by which the custom of building stone monuments reached Oceania from the West. This evidence was revealed by Mr. W. J. Perry (*The Megalithic Culture of Indonesia*, Manchester, 1918), who rendered an even greater service by explaining the motives of the wandering peoples who were mainly responsible for distributing abroad throughout the world the germs of civilization. Men prospecting for gold, copper, silver, tin and other metals, or for flint, turquoise, lapis lazuli, amber or jet, or divers searching for pearls or pearl-shell were the means of planting the elements of culture in outlying places in the world and making them foci of civilization ("The Relationship of the Geographical Distribution of Megalithic Monuments and Ancient Mines," *Mem. and Proc. Manchester Lit. and Phil. Soc.*, 1915; "The Geographical Distribution of Terraced Cultivation and Irrigation," *ibid.*, 1916; "An Ethnological Study of Warfare," *ibid.*, 1917; "War and Civilization," *Bull. John Rylands Library*, vol. iv., 1918).

Since Perry put forward this illuminating suggestion its truth has been repeatedly confirmed by investigations in the British Is., in the Caucasus, in Hyderabad, in Siberia, in eastern Asia, in New Guinea and Oceania, and especially in America. Working out the details of the geographical distribution of the different ingredients of civilization one is now able to reconstruct the past history of the beginning of culture and its diffusion throughout the world. We now realize that the incentive that spurred men on to build up the artificial structure of civilization was primarily the instinct of self-preservation. The realization of the dangers to life impelled men to seek for materials which they believed to be life-giving or death-averting. This was the original value attached to pearls and gold, to incense and jade, and to most of the things which the earliest members of our species sought for in the belief that no adventure was too hazardous and no danger or difficulty too great if by overcoming it they could secure the elixir of life (Elliot Smith, *The Evolution of the Dragon*, Manchester, 1919).

*The Beginning of Agriculture.*—If one single event more than another can be regarded as the foundation of civilization it is surely the invention of agriculture. Much speculation has been made as to where and how this crucial event was brought about; but the breeding experiments of such investigators as Prof. Biffen of Cambridge and the late Mr. Aaronsohn (see Coulter, *Fundamentals of Plant Breeding*, 1914, p. 192) dispose once for all of the popular view that primitive man more than sixty centuries ago produced the barley and wheat, which has been the staple foods of a large section of mankind since then, by an elaborate and long-continued process of experimental breeding. Having disposed of this anachronism, one is in a better position to appreciate the cogency and conclusiveness of the claim set up recently by Prof. Thomas Cherry of Melbourne ("The Discovery of Agriculture," *Proceedings of the Australasian Association for the Advancement of Science*, 1921), that the Nile valley was the place where barley was found growing in a natural state, and that agriculture associated with basin irrigation was invented simply by imitating the natural conditions which the proto-Egyptians had constantly before their eyes. Dr. Cherry has pointed out that in Egypt alone the climatic and seasonal conditions are favourable for the natural growth of barley; and we know that it was the staple diet of the earliest Egyptians (G. Elliot Smith, *The Ancient Egyptians*, 1911, p. 41). The climatic conditions in Mesopotamia, Syria, and Asia Minor are such that the cultivation of barley became possible there only when men applied the lessons of artificial irrigation which they had acquired in Egypt. Dr. Cherry believes that wheat must have grown naturally on some of the smaller Aegean islands—he mentioned Melos and Naxos—who was first cultivated centuries after barley and by men who had learned the art of agriculture directly or indirectly from Egypt. But before the close of the fourth millennium the Egyptian technique of agriculture and irrigation had been adopted in Sumer and Crete and probably also in Syria and Asia Minor. Soon afterwards it was to spread N. and E. to Turkestan and Beluchistan

and in the W. to Europe, as one of the distinctive features of the Neolithic Age there.

The effect of the discovery of a means of securing a certain food supply capable of being stored for use in the lean periods of the year not only led, for the first time in the world's history, to a settled community and a steady increase in population within the settlement, but in addition it gave men leisure to think of other things than the mere struggle for existence. It is no mere chance circumstance that the invention of agriculture is intimately related to the development of the potter's art, to the building of more pretentious houses, to the weaving of linen, and the domestication of milk-giving cattle. But it also provided the predisposing circumstances that compelled the organization of labour and the assumption of control of his fellow men by a leader who became a king, and brought about the curious result that the chief function of this earliest ruler was to be the irrigation engineer to the community, as we know to have been the case both in Egypt and Sumer. As this settled community in the Nile valley increased in numbers the necessity was forced upon it of making more ample provision for disposing of its dead; and out of the circumstances that attended these events there came into existence the arts of the embalmer, the carpenter and the stonemason. Architecture had its birth in the proto-Egyptian necropolis. Ship-building also was invented in close association with this train of events; and the first great maritime expeditions of which any hint has survived had for their object the obtaining of materials needed by the embalmer and the tomb-builder. Probably in the fourth millennium sea-going ships were already trafficking to Syria, Asia Minor and Crete, to southern Arabia and E. Africa (Elliot Smith, "Ancient Mariners," *Journal of the Manchester Geographical Society*, 1917).

*The Beginning of Civilization.*—After many years of fluctuating diversities of opinion it is now widely admitted that there is a very close genetic relationship between the earliest civilizations of Egypt and Babylonia. The identity of their burial customs, their methods of agriculture and irrigation, the use of bricks, cylinder seals and mace-heads, the use of copper and painted pottery, the weaving of linen and the choice and methods of preparing cosmetics, and above all their beliefs and religious practices—these and scores of other customs reveal the fact that the cultures of the earliest peoples of Egypt, Sumer and Elam were derived from a common source. The recent incident that compelled scholars frankly to admit the reality of the cultural link between Egypt and Babylonia in very early times was the acquisition by the Louvre of a predynastic flint-knife with a handle carved from the tooth of a hippopotamus which is said to have come from Gebel el-Arak near Nag'Hamadi in Upper Egypt (Bénédite, "Le couteau de Gebel el-Arak," *Fondation Eugène Piot, Mon. et Mém.*, xxii., i., 1916). The design engraved on the handle is claimed to be very un-Egyptian and to afford certain evidence of cultural contact with Sumer. But many scholars now claim that Egypt obtained the elements of her civilization from Sumer (see, for example, Prof. S. Langdon, "Early Chronology of Sumer and Egypt," *Nature*, May 5 1921, p. 315). In support of this contention Prof. Langdon claims that "recently discovered dynastic tablets establish the date of the earliest kingdoms of Mesopotamia as early as 5000 B.C."; whereas he attempts to fix the beginning of the first Egyptian dynasty by comparing the methods of year-dating of the famous Naram-Sin (2795-2739 B.C.) with those of Egypt, arguing that Naram-Sin borrowed his system of year-dating from Egypt and was contemporaneous with the last two kings of the second Egyptian dynasty. He claims to have confirmed the date circa 3200 B.C. for Menes. But a wholly unexpected revision of Egyptian dating has come from the German school of archaeology which was responsible for the minimal date 3200 B.C. which Prof. Langdon claims to have established by independent evidence.

Prof. L. Borchardt has recently set forth at length a series of arguments, mainly based on astronomical data, to prove that the first Egyptian dynasty began in 4186 B.C. and that the

sixth dynasty lasted from 2920 to 2720 B.C. (*Die Annalen und die Festlegung des Alten Reiches der Ägyptischen Geschichte*, Berlin, 1919). This new estimate, even if it should prove to be true, would not necessarily be fatal to Langdon's claims. But there are reasons of other kinds that demonstrate the derivation of Sumerian and Elamite culture from Egypt.

If it can be shown that Egypt was the home of the invention of agriculture and irrigation, of the working of gold and copper, of the weaving of linen and the making of bricks, of the building of sea-going ships and the use of incense it necessarily follows that Sumer and Elam must have acquired these practices from Egypt, especially as Prof. Langdon rightly claims that the spread of culture took place mainly by sea-routes. As neither the Sumerians nor the Elamites are known to have built sea-going ships nor to have had any motives for doing so, one naturally assumes that the Egyptians (as the builders of the earliest known sea-going ships) took the initiative in opening up the communication by sea with the Persian Gulf, as we know they did with Crete and the coasts of Palestine, Syria and the Red Sea. But the facts brought to light by the French excavations in Elam seem to prove quite conclusively that the predynastic civilization of Egypt was planted there, probably by miners working the copper ore.

Perhaps the most valuable evidence bearing on the early inter-relationships of Egypt, Elam and Sumer and the wider spread of their cultural influence is afforded by the important study of early painted pottery, which M. Edmond Pottier contributed to the valuable series of reports of M. de Morgan's *Délégation en Perse* ("Étude Historique et Chronologique sur les Vases Peints de l'Acropole de Suse," *Mémoires de la Délégation en Perse*, Tome XIII. "Recherches Archéologiques," 5<sup>me</sup> Série, 1912, p. 27). According to him Susian ceramic ware is revealed as the product of a very primitive civilization; but in addition it recalls (or perhaps it would be more correct to say, reveals the germ of) certain highly perfected industries such as that of the Greeks. It is, in fact, an amazing mixture of inexperience and skill—the sort of result one might expect to find when an industry which has been developed elsewhere is suddenly transplanted to a new country, and work requiring special skill is unavoidably entrusted to the incompetent hands of local artisans. The Susian workmanship in fact displays clearly the fact of the derivation of the ceramic craft from elsewhere.

In the lowest level in which there is any evidence of human occupation at Susa, pottery was found in association with copper and stone weapons. This suggests, according to Pottier (p. 60), that the pottery is Eneolithic and that the first colonization of Susa took place in the Eneolithic epoch. For in this lowest level the evidence of the arts and crafts indicates that a fully-developed civilization was present from the beginning of the Susian record preserved for us to study. Linen, for example, was found along with the weapons—an association with copper and painted pottery which further strengthens the proof of the Egyptian origin of the imported Susian civilization. Necklaces of lapis lazuli and turquoise afford evidence, according to Pottier (p. 61), of foreign relations. They suggest, in fact, the possibility of connexions with the regions around the southern end of the Caspian (13 and 14) where these stones are found and were worked in very early times.

Discussing the date of these earliest Susian remains M. Pottier (p. 65) thinks that they are slightly earlier than any of the known Sumerian objects: but he is not inclined to accord them an age many centuries earlier than the time of Ur Nina of Lagash (2800 B.C.). It seems quite clear that there are no valid reasons for attributing to any Elamite or Sumerian remains a date earlier, if indeed as early, as that of the First Egyptian Dynasty. Now the proto-Egyptians had been working copper, making linen and painting pottery, for many centuries before this earliest possible date for the commencement of Elamite and Sumerian civilization. Hence, as undoubtedly borrowing did occur, it is clear that Elam and Sumer acquired the germs of their civilization directly or indirectly from Egypt, or from the same source as Egypt.

M. Pottier does not go so far as to make this claim, but he submits all the evidence that makes its adoption unavoidable:—"En examinant les monuments égyptiens de l'âge préhistorique et des premières dynasties, tout le monde sera frappé des traits de ressemblance nombreux qu'ils présentent avec les trouvailles élamites des couches les plus anciennes. . . . (En Egypt) on retrouve des formes, des sujets, des détails de technique qui évoquent aussitôt le souvenir des antiquités de Suse: vases de pierre dure et d'albâtre" (p. 82). M. Pottier discusses the problem in its wider bearings (pp. 83-85), and elsewhere (pp. 67 et seq.) sets forth his views on the psychology of originality in invention and of the significance and the manner of cultural diffusion. Though he does not claim that Susa borrowed from Egypt, he is quite clear that the proto-Elamite culture was imported from Susa, and he sets forth the evidence which in fact demonstrates that Egypt must have been the source of its inspiration. On p. 66 he again discusses the antiquity of the proto-Elamite civilization and repeats his remarks about the earliest immigrants into Elam in these words:—"Quand ces envahisseurs s'installèrent sur les faibles hauteurs, de neuf à dix mètres à peine, qui bordaient la rivière (J. de Morgan, *Revue d'Assyriologie*, 1909, p. 2), ils étaient déjà en possession d'une civilisation raffinée." They had copper weapons and utensils; their women had mirrors; they had fine clothes, etc.

If it is indeed a fact that Elam was colonized before Sumer, the question naturally suggests itself why the newcomers were not content to exploit the fertile banks of the Tigris and Euphrates, but should have chosen the less attractive and rocky country of Elam for their settlement. The answer to this question has been provided in advance by Mr. W. J. Perry's investigations (*Memoirs and Proceedings, Manchester Literary and Philosophical Society*, 1915) which explain why civilized immigrants in other parts of the world have chosen certain regions to exploit and neglected apparently more attractive places. The Egyptian immigrants into Elam were undoubtedly prospecting for copper ore. In his book *Les Premières Civilisations* de Morgan refers to Elam as one of the two "foyers des inventions métallurgiques" on the ground that copper implements were found in the earliest strata there and the mountains of Elam are "riches en minerais cuivreux" (p. 169). But it was the ore which attracted the foreigners and induced them to settle in Elam.

There is evidence of various kinds to suggest that at or about the time when the Elamite and Sumerian civilizations were founded there was a widespread prospecting of the mineral resources of western Asia and the lands around the eastern Mediterranean. The objects of this search were gold and copper, lapis lazuli and turquoise, pearls and shells.

We have already seen that the proto-Elamites had lapis lazuli and turquoise and suggested that they must have gone as far afield as the Caspian to obtain these stones. That they did actually exploit this region is shown by the results of the Pumpelly Expedition (Ralph Pumpelly, *Explorations in Turkistan*, Carnegie Institution, 1908) in Russian Turkistan, where painted pottery of proto-Elamite type was found in the neighbourhood of certain ancient copper-workings. There can be no doubt that Susian prospectors went to the Caspian area to obtain copper ore, and incidentally got lapis lazuli and turquoise. In the lowest stratum in the northern kurgan at Anau, Pumpelly found hand-made painted pottery, cultivated wheat and barley, turquoise beads, mace-heads, copper and lead, and rectangular houses of sun-dried brick (vol. i, p. 33). At a somewhat higher level he found in addition beads of lapis lazuli and carnelian (p. 42). It was only at a later time (his so-called "Culture 3," found in the southern kurgan at Anau) that pottery turned on the wheel was found: in the same level tin mixed with copper, and evidence of an "intentional alloying with lead" was obtained; also figurines of a goddess and a cow. Of the earliest culture Hubert Schmidt tentatively estimates the age as "in the third millennium," the second in the latter half of the second millennium, and the third approximately 1000 B.C.

Pottier also summarizes (*op. cit.*, p. 71) the whole discussion: "According to Hubert Schmidt (*Revue archéologique*, 1910, I,

p. 307) the most ancient pottery from Anau may be contemporary with that of Susa, but he believes it to represent an extension of Elamite art to Turkistan." In a great part of the Transcaspien region of Turkistan "au delà de l'Orouz," north of the Pamir plateau between Samarkand and Kashgar, the finding of objects made of metal or pottery analogous to those of Mesopotamia (Pottier, p. 70) affords additional evidence of the diffusion of Elamite, Sumerian and Babylonian culture in very early times.

It is clear then that the search for copper ore, lapis lazuli and turquoise led to the diffusion of proto-Elamite culture far into Turkistan. But the same reasons led to its spread to Armenia, the Caucasus and Asia Minor in the west and at least as far as Baluchistan, and probably India, in the east.

In Armenia and the Caucasus painted Susian-like vases do occur, but only very rarely (Pottier, p. 73). "Cette poterie du Caucase, dont la date n'est déterminée, est sans contredit affiliée par la tradition à la fabrique élamite" (p. 74). In Galatia and Cappadocia painted pottery of the same type is found, which is certainly not of Aegean inspiration (p. 74). Similar pottery is found also in Phrygia and Mysia (p. 76); and M. Pottier suggests that between early times and the period of the eighth and seventh centuries B.C. Susian influence percolated into Phrygia from the neighbouring lands. The geographical lines of the spread of this culture seem to have been determined mainly by the distribution of copper and gold. Elamite pottery has been found north of the Black Sea in Scythia (Pottier, p. 74). Without any definite reasons, so far as I understand his report, M. Pottier thinks that, although the designs upon the painted pottery of the Thracio-Phrygian area are similar to those of the Susian ware, the inspiration was independent. However, he thinks that Lydia and Caria, Syria and Palestine were influenced both by Elam and Egypt about the middle of the third millennium. Once one admits the motive and considers the times of the respective diffusions of culture, the process and the lines of spread become clear enough. When gold and copper acquired in Egypt for the first time an arbitrary value they were sought for far and wide, not merely in the Eastern Deserts of Egypt and Nubia, but also in Arabia and Elam, in Asia Minor, in the Caucasus and Turkistan. From Egypt there were two main lines of diffusion of culture—one E. to Elam and the other N. to Crete<sup>1</sup> and Asia Minor,<sup>2</sup> and from each of these centres secondary lines of radiation were established.

One of the most striking illustrations of the extent of these secondary radiations and of the motives which prompted them is afforded by the remarkable centre of Elamite culture at the little village of Nal (in the Jhalawan district of Kalat state, lat. 27°40', long. 66°14') in Baluchistan (J. H. Marshall, "A New Type of Pottery from Baluchistan," *Survey of India, Annual Report, 1904-5*, Calcutta, 1908, pp. 105 et seq.; for summaries see *Revue archéologique*, 1909, p. 156, also Pottier, *op. cit.*, p. 72; Noetling, "Ueber eine prähistorische Niederlassung im oberen Zohb-Thal in Baluchistan," *Zeitschrift für Ethnologie*, 1898, pp. 460-470; also "Ueber prähistorische Niederlassungen in Baluchistan," *ibid.*, 1899, pp. 104-107).

The pottery from Baluchistan is painted with designs clearly analogous to those found at Susa, of the culture of which it is clearly either a contemporary offshoot or a persistent survival. On the evidence supplied by Marshall the latter explanation seemed to be the just one; but Noetling has shown that the Baluchistan pottery occurs in what he calls "Neolithic" sites; and it is quite clear that the Elamite ceramic industry extended as far east possibly in the third millennium. The fact that it was found in association with gold deposits and ancient irrigation works completes the proof of the motives and the identity of the introducers of the ancient civilization. The Baluchistan centre of Susian influence possibly represents a stage in the migration of the knowledge of copper (from Egypt, via Susa and Baluchistan) to India, where an early Copper Age culture

<sup>1</sup> See Diedrich Fimmen, *Die Kretisch-Mykenische Kultur* (1921).

<sup>2</sup> A. E. Cowley, *The Hittites*, The Schweich Lectures for 1918 (1920).



developed on the banks of the Ganges (W. Crooke, *Northern India*, 1907, p. 18: "an age of copper is well marked by finds of implements of remarkable shapes in the Ganges Valley").

The search for copper or gold attracted these earliest explorers to Elam, to Asia Minor, the Caucasus and Black Sea littoral, the southern shores of the Caspian and Transcaucasia, and to Baluchistan; but it also led them much farther afield. So that, long before the invention of bronze the germs of ancient civilization were planted in Turkestan and along a series of gold-workings from the Oxus to Bukhara, to Issyk-kul and Kulja, to Barnaul, Krasnoyarsk and Minusinsk, which became the centre where for many centuries the civilization of central Siberia flourished in spite of the fact that it was the lure for the greed of a vast continent and the home of strife (W. J. Perry, "War and Civilization," *Bulletin of the Johns Rylands Library*, 1918).

But it was not merely the chain of golden sands along the line from Bukhara to the Yenisei that attracted the miners from the S., but also the gold and jade in the Tarim valley in pursuit of which the prospectors were led on from Kashgar to Kucha past Lop-nor to Suchan, Liangshan and Lanshan until eventually they discovered the gold and jade in the mountains S. of Si-ngan in Shensi. Settling down to extract this wealth they incidentally planted the germs of the civilization of China. Laufer's memoir on *The Beginnings of Porcelain in China* (1917) (see also his "Some Fundamental Ideas of Chinese Culture," *Journal of Race Development*, vol. v., 1914, pp. 160-174) affords irrefutable corroboration of the fact that "the entire economic foundation of ancient Chinese civilization has a common foundation with that of the West" (p. 175). "It is inconceivable that the (potter's) wheels of India and China should be independent of those of the West" (p. 175). All the facts brought together by Laufer point clearly to the conclusion that the world at large learnt the use of the potter's wheel from Egypt (pp. 174-176). Many centuries later "the incentive for the process of glazing pottery was received by the Chinese directly from the West, owing to their contact with the Hellenistic world in comparatively late historical times. The knowledge of glazing rendered the manufacture of porcelaneous ware possible; yet in this achievement the creative genius of the Chinese was not guided by outside influence, but relied on its own powerful resources" (p. 176).

Elamite civilization was diffused to Turkestan long before wheel-made pottery was made, because Pumpelly's excavations revealed the fact that in the first and second of his culture-stages at Anau only hand-made pottery was found.

The routes followed by these early culture-bearers from Persia to central Siberia and to China respectively are mapped out by the remains of ancient irrigation systems. Wherever gold was to be obtained from any of the streams or lakes these wandering prospectors settled to wash the sands for the precious metal: they also irrigated the land in their characteristic way to grow crops to maintain themselves; and they left stone monuments as memorials for their dead. The association of these three classes of evidence, the presence of gold, ancient irrigation and stone monuments, still blazes the paths taken by these ancient prospectors forty or more centuries ago. Detailed statements of two of these classes of evidence will be found in J. Mouchkeboff's *Les Richesses Minérales du Turkestan* (Paris, 1878) and H. Moser's *L'Irrigation en Asie Centrale* (Paris, 1894).

There is evidence of another kind in substantiation of the intimate cultural link between early Egypt, Elam and Sumer, and between them and the Iranian and Turanian domains. The religious ideas and mythology reveal the closeness of the bonds between these ancient centres, and especially the fact that much of so-called early Aryan beliefs and myths are really Egypto-Sumerian in origin.

But reference has been made to the intimacy of the early cultural bonds between Mesopotamia and Turkestan because it has a bearing upon one of the most important episodes in the history of civilization—the invention of the alloy bronze and the inauguration of the Bronze Age. We know that before the

invention of bronze prospectors for gold and copper exploited the line of deposits of these metals which forms a chain linking the valley of the Oxus to the upper Yenisei. The rich archaeological harvest collected around the sites of these ancient workings establishes this fact. Now if it be true—and the evidence at present available renders it probable—then the making of bronze was invented with the help of the tin obtained from Meshed. Ancient tin mines were discovered in this region by P. Ogorodnikov (compare Baer, *Arch. f. Anthr.* [ix., p. 265], quoted by Terrien de Lacouperie, *Western Origin of Chinese Civilization*, p. 322). "Strabo declares that it (tin) was produced in Drangiana, west of the modern Afghanistan, a district partly coinciding with Khurasan, where its presence has been confirmed. It is also found in other parts of Persia, near Astabad and Tabriz" (C. H. Read, *A Guide to the Antiquities of the Bronze Age*, British Museum, 1904, p. 9.) The exact spot where tin has been found at the south-eastern corner of the Caspian is indicated by J. de Morgan, *Mission Scientifique au Caucase* (1889).

In her important monograph on *Gournia* Mrs. Harriet Boyd Hawes brings forward the following weighty arguments in favour of the invention of bronze in the southern Caspian area: "When the Pumpelly expedition returned from Turkestan in 1904, one of the members brought potsherds indistinguishable at first sight from the brilliantly mottled ware found at Vasiliki (Crete) during the same season. . . . The strong likeness between the two fabrics . . . is more reasonably explained by intercourse than by accident. Moreover, Dr. Hubert Schmidt . . . reports that a neighbouring tumulus (near the large one in which the pottery was found) gave him a three-sided seal-stone of Middle Minoan type, engraved with Minoan designs—man, lion, steer, and griffin. How shall we explain these evidences of Aegean influence in southern Turkestan? They must be brought in line with other proofs of contact. . . . We see that at c. 2500 B.C. Asia Minor shared with the Aegean the knowledge of bronze . . . we may suggest the probability that, long before tin was discovered in Europe, it was being brought overland through Asia Minor, and also by way of Transcaucasia and the Black Sea from distant Khorassan, Strabo's Drangiana. . . . Excavations at Elizabethpol in Transcaucasia have revealed a culture in early contact with the Aegean."

One of the results of this intercourse between Turkestan and Asia Minor was the introduction into Europe of the appreciation of jade, which no doubt was responsible for stimulating the people of Europe to hunt out and work the supplies of nephrite which occur locally.

Terrien de Lacouperie makes the following statement:—

"The precious nephrite (polished celts) is found along the route from Khotan in Turkestan, its starting point, to the Jaxartes, to the Oxus, then S. of the Caspian Sea, in Babylonia and Assyria, along the Northern Asia Minor shores, bordering upon ancient Troy, then passes to the Peloponnesus, where it directs its course to Crete, and, not touching Egypt, passes from Greece to Italy, where it is distributed among the Helvetic Lakes, the Megalithic monuments of Armorica, etc." (*Western Origin of Chinese Civilization*, p. 34.)

*Chinese Civilization*.—There is no doubt that the cradle of Chinese civilization was in the Shensi province early in the third millennium, and that the inspiration of this culture was provided by miners from the W. who were exploiting the gold, copper and jade of the mountains S. of Si-ngan-fu, and incidentally planting in China the much modified elements of Elamite civilization which had been handed on from one mining camp to another on the long route to China.

The occasional use of jade for seal-cylinders in Babylonia and the value attached to turquoise there suggests that the people who were washing the sands of the Oxus, the Syr Daria, Issyk-kul and the Ili for gold—and the presence of distinctive types of ancient irrigation works on the banks of these waters proves the reality of such exploitation—were also working the Tian Shan range and the neighbourhood of Khotan and Kashgar for jade and turquoise. What strengthens the belief in the reality of this suggestion is the fact that the peculiarly arbitrary and distinctive magical significance which was attached to pearls

and gold by the early sailors of the Erythraean Sea was acquired also by jade. The only reasonable suggestion that explains this remarkable circumstance is that these ideas were acquired by the people of Turkestan from Mesopotamian miners, and that the former came to attach to all the materials for which the immigrants were searching the peculiar attributes which these immigrants themselves assigned only to certain of them. Hence jade came to be regarded, like pearls, as the giver of life and resurrection and as a preventive of putrefaction of the corpse.

The problem that must be solved in the explanation of the symbolism of jade in China is the source of its inspiration. Why should jade be regarded as the giver of life and resurrection, the preserver of the dead and the bringer of good fortune? We know how and why the pearl came to acquire these magical attributes. We know also that the ancient Persian word for a pearl, *margin*, "the giver of life," was adopted in all the Turanian languages; so that the word and the idea underlying it spread E. as far as Kamchatka. The exact identity of the ideas concerning (and the methods of using) jade suggest that they must be derived from the pearl-symbolism, and the tentative explanation suggests itself that the people of Mesopotamia exploited the area in the neighbourhood of the Tian Shan mountains for gold and jade, and so transmitted to the people of Chinese Turkestan ideas of the magical properties of jade which in course of time spread due E. to the head-waters of the Hwang-ho river.

"The mountains south of Si-ngan-fu in Shensi Province produced jade, gold, silver, copper and iron in the first century B.C., as expressly stated in the *Annals of the Former Han Dynasty*. . . . The distinguished physician T'ao Hung-King (452-536 A.D.), the author of a treatise on *Materia Medica (Ming i p'eh lu)*, states that the best jade comes from (Lan-t'ien): he mentions also the occurrence of jade in Nan-yang, Honan Province, and in the Lu-juug river of Tonking, also that brought from Khotan and Kasgar" (Laufer's *Jade*, p. 24).

Laufer denies that jade was imported into China from Turkestan before the commencement of the Christian era; and also seems to be opposed to the idea that the magical value attached to jade in China was suggested by the West.

"While from about the Christian era Turkestan became the chief source for the supply of jade to China, to which Yunnan and Burma were later added, neither Turkestan nor Yunnan came into question in very early times. The jades used in the period of the Chou, and most of those of the Han Dynasty, were quarried on the very soil of China proper. It was doubtless the Chinese themselves who, being acquainted with jade in their country, probably for millenniums, gave impetus to the jade fishing and mining industries of Turkestan. Also this case may throw a side-light on the nephrite question of Europe: home-sources do not exclude imports, and scarcity or exhaustion of sources may favor them" (Laufer, *Jade*, pp. 23 and 24).

But Laufer's hypothesis of the origin in China of the special appreciation of jade will not bear examination. The search for gold in Turkestan was certainly begun by people from the South. There can be no doubt that the same people who washed the sands of these rivers of Turkestan for alluvial gold and freshwater pearls also inaugurated the practice of "fishing for jade." The proof of this inference is provided by the fact that jade acquired precisely the same reputation and had attributed to it the same remarkable repertory of magical properties as these southern miners associated with pearls and gold.

Dr. Laufer himself puts the matter in its true perspective when he is discussing the problem of European jade (p. 5). His argument is so apt and incisive that it is tempting to use it to demolish his own hypothesis:—

"Nothing could induce me to the belief that primitive man of central Europe incidentally and spontaneously embarked on the laborious task of quarrying and working jade. The psychological motive for this act must be supplied, and it can be deduced only from the source of historical facts. From the standpoint of the general development of culture in the Old World, there is absolutely no vestige of originality in the prehistoric cultures of Europe, which appear as an appendix to Asia. Originality is certainly the rarest thing in this world, and in the history of mankind the original thoughts are appallingly sparse. There is, in the light of historical facts and experiences, no reason to credit the prehistoric and early historic populations of Europe with any spontaneous ideas relative to jade; they received these, as everything else, from an outside

source; they gradually learned to appreciate the value of this tough and compact substance, and then set to hunting for natural supplies."

Substitute "China" for "central Europe" in this admirable statement, and it applies with equal force. For the Chinese had no reasons for attaching a special value to jade until they were inspired to do so by ideas which came to them from elsewhere. Laufer claims that the question can only be settled on the basis of historical fact. His argument also implies that the idea of working jade spread from one centre. In other words, if we accept his teaching, the use of jade in Europe during the early Bronze Age was inspired by events in the Shensi province of China! What historical evidence is there, first, for assigning such a remote date for the exploitation of jade in China, and, secondly, for the transmission of the knowledge of these events from China to Switzerland nearly 40 centuries ago?

In Turkestan we find definite reasons for the appreciation of and the commencement of the working of jade. We have also found some evidence to justify the hypothesis that the making of bronze was invented in close proximity to Turkestan. The people who introduced the knowledge of bronze-making into Europe, also introduced the appreciation of jade.

If, however, we accept Laufer's view that Chinese culture inspired the appreciation of jade in central Europe in the second millennium B.C., or even earlier, presumably the channel passed *via* Turkestan. Part of his argument (see above) was based upon the fact that the Chinese jade traffic with Turkestan was unknown before the beginning of the Christian era. But if there was this early intercourse with Turkestan, the fact that the Babylonians or whoever was exploiting the wealth of that country, attached a special value to gold, pearls and jade can hardly be left out of account in considering the origin of Chinese ideas. Is it likely that the exact coincidence between these wholly arbitrary ideas in China and Babylonia respectively were independent the one of the other? Dr. Laufer himself rightly scouts the idea of such independent development. If so he must admit that the Chinese ideas concerning jade must have been inspired by the West.

Light is thrown upon these problems by the study of the metal implements found in Siberia and elsewhere. In his admirable *Guide to the Antiquities of the Bronze Age* (British Museum, 1904), Sir Hercules Read summarizes the evidence in an impartial manner:—

"At the extremities of the vast area stretching from Lake Baikal through the southern Siberian steppes across the Ural Mountains to the basin of the Volga, and even beyond to the valleys of the Don and Dnieper, there have been found, generally in tombs, but occasionally on the surface of the ground, implements and weapons marked by the same peculiarities of form and by a single type of decoration. These objects exhibit an undoubted affinity with those discovered in China; but some of their distinctive features have been traced in the Bronze industry of Hungary and the Caucasus: for example, pierced axes and sickles have a close resemblance to Hungarian and Caucasian forms. The Siberian bronzes have thus relationships both in the East and West; but their kinship with Chinese antiquities being the more obvious, it is natural to assume that the culture which they represent is of East Asiatic origin. The presumable antiquity of Chinese civilization (which after all is only a presumption); the continued westward tendency of migration in historical times (which, however, were started by the disturbances in the gold region of the Altai; and therefore tell against Sir Hercules Read's argument); and the fact that the greatest centre of discovery lies far away to the East in the basin of the Yenisei, in the districts of Minusinsk and Krasnoïarsk, are all points which may be urged in support of this view."

To the objections which we have interpolated in this quotation, Sir Hercules Read himself adds others. The Chinese implements are "not of primitive forms"—

"Their prototypes are found neither in the Ural-Altai region itself, where some objects may indeed be simpler in design than others but cannot be described as quite primitive; nor as yet within the limits of China itself" (p. 107).

<sup>1</sup> Pages 106-111 compare also the fuller and more recent summary of the evidence in the book by Minns, *Scythians and Greeks*, in which, however, the statement is marred by an uncritical acceptance of the dogma of independent evolution of culture.

<sup>2</sup> See Perry's Rylands Library Lecture, *War and Civilization*.

The true solution of the problem will be reached when it is recognized that the basin of the Yenisei and China represent the two termini of a stream of culture which passed N. from the southern end of the Caspian Sea and divided at the Tian Shan range into two branches, one of which passed more immediately to the Yenisei and the other via Khotan and Kashgar ultimately to China. Sir Hercules Read hints at the possibility of this explanation without, however, definitely committing himself to it:—

"The similarities existing between the Far Eastern and Hungarian groups will not be fully explained until the Bronze Age of southern Asia as a whole is far better known than it is at present (1904). According to a view which has found some acceptance, the common elements may have been derived from some centre in southern or south-western Asia, from which issued two streams of influence, one passing to the N. of the Caucasus, the other to China by a southerly route" (p. 109).

Further, in his account of the Siberian implements, Sir Hercules Read adds:—

"The most characteristic ornament represents animals of local species, bears, reindeers, wild goats, etc., the monsters characteristic of the later Iron Age tombs being absent. Sometimes the heads of animals are placed back to back so as to form the guards of daggers, a disposition which has some resemblance to those of daggers represented upon Assyrian monuments" (p. 110).

Correlating all the facts and suggestions brought together by de Morgan, Pumpelly, Laufer, Read, Hawes and Minns, and interpreting them in the light of Perry's illuminating demonstration of the vital part played by the search for gold, copper, pearls and precious stones, we find the general explanation seeming to emerge quite definitely, even if the details still remain to be worked out.

From the third millennium the mines on the S.E. of the Caspian were being exploited and contact was established between Babylonians, Elamites and the population of Turkestan. The northerly extension of Mesopotamian cultural influence established further contact with the Mediterranean in the West, and both directly and indirectly with the strip of rich metaliferous country stretching along the Caucasus from the eastern coast of the Black Sea to the Caspian. At the same time, from the eastern and south-eastern shores of the Caspian there was a further extension of mining activities E. and N.E. to the Oxus, to Samarkand and Ferghana, and to the S.E. of Lake Balkash. From the great southern Caspian centre of the Bronze industry there were drifts of cultural influence to the Aegean and the Black Sea, to Turkestan and China itself.

The invention of the alloy bronze was an event of most momentous importance in the history of civilization; the determination of the exact place whence the knowledge of this procedure was diffused to the ends of the earth is therefore a point of exceptional significance: hence the facts and arguments which point to the neighbourhood of the Caspian early in the third millennium as the place and time of this event have been set forth here in some detail.

*Social Organisation and Totemism.*—One of the most potent factors in shaping the beliefs and customs of the world at large was the result of an ingenious device on the part of the priesthood of Heliopolis to attain their own selfish aims, namely, of increasing their political power and influence and enhancing their social status. Until the period of the Fourth Dynasty in Egypt the royal family controlled the whole of the priestly and administrative functions of the State. The king was the high priest and his eldest son the grand vizier. Each of the administrative districts of the State—the nomes—was governed by a member of the royal family. Hence the whole government of the State was concentrated in the hands of one family. But from the earliest times the priesthood of Heliopolis had played an important part in Egypt. They were responsible for the astronomical calculations necessary for the prediction of the annual flood of the Nile, on which the welfare of the whole country depended. At Heliopolis the first nilometer was set up, and in all probability the first solar calendar was devised there. In course of time it became the centre of the solar cult which superseded (or rather adopted and profoundly modified) the Osirian belief in the river as the source of all life. Having built

up the solar theology at the end of the Fourth Dynasty the priesthood of Heliopolis made a bold bid for power by putting forward the prophecy that Re, the sun god, would be the father of the first king of the Fifth Dynasty by the wife of the high priest of Heliopolis. Hence arose the custom of regarding the chosen people as "children of the sun" and believing in the virgin birth of kings and gods—arbitrary elements of culture the widespread distribution of which throughout the world is a striking token of Egyptian influence in the upbuilding of civilization. The ingenious device of the Heliopolitan priesthood to seize control of the State was not wholly successful, but resulted in a dual organization of the Government, the Heliopolitan family controlling the priestly duties and the Memphite (the old royal) family the civil administration. This splitting of responsibility and control led to a rapid disintegration of the governing power and at the end of the Sixth Dynasty the State was reduced to a condition of anarchy. But the effect of this remarkable experiment in government became widely diffused beyond the boundaries of Egypt; and the dual organization of the community and the use of such phrases as "son of the Sun" were carried far afield, even to Oceania and America. In the whole extent of the regions from Egypt to America we find traces of two well-marked phases of civilization. The earlier represents a form of social organization essentially identical with that of Egypt of the Fifth Dynasty:—sun-cult; a dual kingship, one ruling family being concerned with secular and another with priestly functions; and a dual division of the State, which even extends to individual villages. It seems probable that the priesthood which originally devised this dual organization realized the danger of the cleavage and the risk of disintegration inherent in it, and introduced the principle of exogamy to maintain the coherence of the community that was split into two conflicting moieties by compelling the members of the divisions to intermarry.

In many places this phase of culture gave place to another derived directly from it by a process of inevitable disintegration following on the splitting off of daughter settlements. In this secondary process the sun-god became known as a war-god: the kingship ceased to be dual, and the dual organization of the State and the village tended to disappear with greater or less rapidity according to local circumstances.

In the early phase of dualism the two rulers were assisted in the administration by a council, the members of which were the representatives of local groups (the Egyptian nomes), usually clans associated with some animal from which they claimed descent. (The reason for this remarkable belief, known as totemism, is probably to be found in the fact that the earliest Egyptians regarded the milk-giving cow not merely as a foster-mother but as the actual Great Mother of mankind. When the nomes adopted as badges a series of distinctive animals, these maternal functions were attributed to all of them.) Like the kingship this totemic council was also dual, one section being concerned with peace and the other with war. It often happened that the ruling power disappeared and then we find that the people deliberately maintained the council as the proper means of preserving the constitution with which they are familiar. Thus is produced a state of affairs commonly called the dual organization in which the country is divided into two parts with different characteristics. Just as in Egypt one kingdom was known as the white crown and the other as the red, so in many parts of the world one moiety is connected with the colour white (or a light colour) and the other with red (or a dark colour). One is associated with the sky and with peace and is regarded as superior, the other with the earth, the underworld, and war and is regarded as inferior.

A feature of the dual organization is the council of old men—the gerontocracy—which is regarded as of the utmost importance. The various groups of the dual organization in its pure form appear to be what are called totemic clans. The basis of this system is to be found in the doctrine of totemism, which as we have seen was invented by the priests of Heliopolis to serve their own personal ends.

There was a vast amount of speculation during 1910-20 as to the meaning of totemism, an impartial and full summary of which has recently been published by Dr. Arnold van Gennep (*L'Etat Actuel du Problème Totémique*, Paris, 1920). But recent research (and especially the unpublished researches of W. J. Perry, which the present writer has been permitted to see and use) makes it abundantly clear that, wherever it is found, totemism has been derived directly or indirectly from the beliefs and practices associated with the ruling classes in Egypt during the Pyramid Age, to which reference has already been made. When one investigates the more primitive forms of totemism and realizes the part played in them by such ideas as matrilineal descent from animals, virgin birth, children of the sun, and the belief in the protective value of animal crests, there can no longer be any doubt as to the derivation of these conceptions from Egypt of the Fifth Dynasty.

In the foregoing account it has been claimed that a very intimate connexion exists between the dual organization and the system of totemic clans. This is not an accidental circumstance, as is often assumed, but is the inevitable result of the conditions under which the dual system arose in Egypt. No doubt this will be regarded as a very heterodox claim; but the facts in proof of it are certain and their meaning quite conclusive. Although the dual organization now survives only in India, Oceania and America, there are marriage customs with a much wider distribution, notably in Africa, which point to the influence of this social system in earlier times. In Australia there are very complicated systems of rules to regulate marriage: but in many tribes they afford a very striking demonstration of the original connexion between the dual system and the totemic clans. The dual chieftainship still persists in Polynesia and New Guinea, as it did in Japan until the Shogunate became virtually extinct a few years ago. According to Géza Róheim (*Man*, 1915, p. 26) there are very definite traces of the same customs among the Ural-Altaic peoples. He refers especially to the double kingship of the Khazars as being essentially similar to the Mikado-Shogun system of Nippon.

The vast importance of the study of social organization has been emphasized by Dr. W. H. R. Rivers within recent years (*Kinship and Social Organization*, London, 1913; *History of Melanesian Society*, Cambridge, 1914), and in his hands the use of the data relating to marriage regulations and relationship has become a most valuable instrument for investigating the problems of ethnology and the diffusion of culture. (G.E.S.)

**ANTISEPTICS** (see 2.146).—During recent years the study of antiseptics has proceeded mainly along two lines—attempts have been made to produce more efficient antiseptics for use in the ordinary way by external application, and chemical substances have been elaborated which when injected into the circulation destroy the microbes with which they come in contact. At the same time many studies have been made on the natural antiseptics by which the body rids itself of infection.

*Antiseptics Naturally Occurring in the Human Body.*—It is well known that we are constantly coming in contact with disease-producing microbes and yet only comparatively rarely does an infection result. It is also well known that an individual who has been living in a secluded spot which was comparatively free from infection, when brought into a city where infection is common, is very much more liable to infection than an individual who had been living in the city. The latter by coming in contact with the microbes has developed a partial immunity to the common infections, so that, while the stranger will rapidly succumb to the infecting microbe, the partially immune person will be able in many cases to resist it. This immunity is due to an increase in the amount of anti-bacterial substances of the body fluids, and to a better organization for the mobilization of the defences of the body towards the point of attack.

In the simplest cases, where microbes are introduced into the body by the instrument which inflicts the wound, there is very quickly produced a dilatation of the surrounding blood-vessels which increases the blood supply to the infected region. This is followed by an increased transudation of the fluid portion of the

blood from the vessels into the infected tissues, and by an emigration from the blood of the white corpuscles or leucocytes, which are amoeboid bodies capable of ingesting the microbes and destroying them.

With some infecting agents such as the typhoid bacillus the fluids of the blood have a great power of killing the microbes, but in most of the commoner infections this power is not so manifest and the leucocytes are the chief agents in their destruction. The quality of the fluids even in these cases is, however, of great importance in preventing the increase of the microbes, and in acting on them so that the leucocytes can readily take them up and complete their destruction. Almoth Wright has shown that in cases of severe infection the power of the blood serum to neutralize tryptic ferments (the antitryptic power) is much increased, and by virtue of this increased antitryptic power the growth of the microbes is greatly hindered in the serum. He has shown also that the alkalinity of the blood is of great importance in retarding the growth of some microbes such as those which cause gas gangrene. He has also shown that the serum will act on the microbes by virtue of its opsonic action so that they can be taken up by the leucocytes and destroyed. These observations on the opsonic power of the serum form the basis for modern vaccine-therapy, which has been of such benefit in combating many infections.

It has been shown that the leucocytes of the blood, and also the leucocytes which exude from the blood into an infected wound and constitute pus, have a very powerful action in destroying the ordinary septic microbes, and these natural antiseptics have the great advantage over the chemical antiseptics that they act mainly on the microbes which are imbedded in the tissues, and not merely on the microbes on the surface of the wound. In all wounds in which an infection has been established the majority of the microbes are in the tissues well below the surface of the wound, and are quite inaccessible to chemicals applied to the surface.

During recent years research has been directed to the action of chemical antiseptics on the natural defences of the body, and it has been shown that the cells of the body are more susceptible to the chemicals and are more easily killed by them than are the microbes, so that it is clearly impossible to kill by means of one of the ordinary chemical antiseptics the microbes imbedded in the tissues, unless at the same time the tissues are destroyed.

*Chemotherapy.*—The ideal method of using an antiseptic is to introduce it into the circulation so that it reaches every portion of the infected focus and destroys the microbes. For the ordinary bacteria this ideal had not yet been attained in 1921, but remarkable advances had been made in this direction in certain infections. In 1910 Ehrlich prepared an organic arsenical product which when injected into the body rapidly destroyed the microbe of syphilis, and this product, salvarsan, or a later and more easily administered product of somewhat similar constitution, neo-salvarsan, has revolutionized the treatment of this disease. Following Ehrlich, Morgenroth prepared a chemical substance which had a remarkable affinity for the pneumococcus (the microbe which causes pneumonia), and destroyed it in very high dilution, whereas it had little lethal action on other bacteria. It was found that Morgenroth's drug (optochin) lost much of its lethal power on the pneumococcus when injected into the animal body, and also it had certain poisonous effects on the animal tissues, so that in practice it had not been useful. The fact, however, that drugs can be prepared that have a very specific action on one microbe offers some hope that in the future there will be produced chemicals which will be able to destroy the ordinary disease-producing bacteria, without damaging the tissues, and so give us an easy and certain remedy for the common infections.

*Chemical Antiseptics for Application to the Wound.*—Prior to the World War the use of antiseptics in surgery had been largely discarded in favour of "aseptic" methods, in which the aim was to prevent the access of the microbe to the wound. During the war, however, it was found that all wounds were infected with septic microbes, and many antiseptic methods

were employed in the hope of destroying these microbes. At first, antiseptics such as carbolic acid and iodine were used, but they were found to be ineffective in preventing the spread of the infection. Then antiseptics of the chlorine group which were derived from bleaching powder came into vogue, and these were found to be much more useful, although their exact value was obscured by the great advances made in the surgery of the wounds at the same time. These chlorine antiseptics act very quickly on the microbes, but at the same time they are very rapidly destroyed in the wound, so that after about 10 minutes they have lost their antiseptic value. It was the common practice to instil these antiseptics into a septic wound every two hours in the hope of keeping up a constant supply of the antiseptic, but as the active agent is destroyed in about 5 or 10 minutes it follows that for the greater part of the time there was no antiseptic in the wound. Fleming has shown that in all probability the beneficial action of these so-called antiseptics was not in their power of destroying microbes but in their power of aiding the natural antiseptic defences of the body.

In the simplest form these chlorine antiseptics were solutions of hypochlorous acid (ensol) or sodium hypochlorite (Dakin's fluid), but later Dakin introduced more complicated organic preparations, such as chloramine T. and dichloramine T., which were more stable and contained a greater percentage of the active agent. These later applications have never attained the popularity of the simpler compounds.

Morison introduced into war surgery a procedure in which the wound, after being thoroughly cleansed, was rubbed over with a paste consisting of bismuth, iodoform and paraffin (Bipp). This obtained a considerable popularity, and it was supposed to act by virtue of the iodoform, which is not in itself an antiseptic, being broken down in contact with the blood fluids with the liberation of iodine. Experiments showed, however, that there was not sufficient iodine liberated to act as a lethal agent for bacteria in the body fluids, and it is probable that, like the chlorine antiseptics, this depended largely for its beneficial action on its power of aiding and conserving the natural defences of the body.

The last types of antiseptics to be introduced into war surgery were the aniline dyes. The power of some of these dyes as anti-bacterial substances had been previously investigated. Churchman had shown that gentian violet would kill many varieties of bacteria (those which stain with Gram's method) in a dilution of 1 in 1,000,000, or less, while it had little lethal action on other varieties which did not stain by Gram's method. Another dye, brilliant green, had been used in bacteriological technique for the isolation of typhoid bacilli, owing to its having a less lethal action on these than it had on the other and more common bacteria. Browning introduced into surgical practice another dye of the acridine series, called by him flavine or acriflavine, which had been originally prepared by Benda at Ehrlich's suggestion for the destruction of trypanosomes (the parasites of sleeping-sickness). Flavine differed from all the other antiseptics in that it acted more powerfully in the presence of blood serum than it did in water. Great hopes were therefore entertained that it would be able to deal effectively with the bacteria in an infected wound. It was found, however, that it was rapidly fixed by the body tissues and by the dressing of the wound, and in practice it was not found to have advantages over the other antiseptics in common use.

Towards the end of the war all the chemical antiseptic solutions fell more or less into disuse and more reliance was placed on efficient surgery and the natural antiseptics of the body. The greatest advance in the treatment of infected wounds was the efficient cleansing of the wound, the removal of all dead tissues, and the immediate closing of the wound so that the natural antiseptic defences could exercise their functions to the greatest advantage. It was found that when physiological salt solution was used the results of this procedure were as good as when chemical antiseptics were employed.

Since the war conditions have been removed antiseptics have largely disappeared from surgical practice, and a return has

been made to "aseptic" methods, in which microbes are, as far as possible, excluded from the wound and the natural defences of the body are left to deal with the few microbes which may gain access. (A. Fl.)

**ANTOINE, ANDRÉ** (1858— French actor-manager (see 2.148), opened in 1897 his Théâtre Antoine in Paris, which for 10 years he made famous as a home of modern realistic drama, playing in particular the works of Brieux, Hauptmann and Sudermann, and staging a French version of *King Lear*. He returned to the management of the Odéon in 1906 and there produced *Julius Caesar*, *Coriolanus* and a large number of classical and modern dramas, but he retired in Feb. 1914. He was subsequently engaged in writing his memoirs.

**ANTWERP, Belgium** (see 2.155).— Pop. (1914) 313,833; but, including Borgerhout (52,126) and Berchem (32,257), total pop. 398,216. The projected *grande coupure*, or cutting through the neck of the loop in the river Scheldt immediately below Antwerp, was abandoned, and, in place of this scheme, three extensive wet-docks were constructed between 1903-14. In 1913, 7,142 vessels of aggregate tonnage 28,270,000 entered the port as compared with 6,095 of 19,662,000 tons in 1905. The decision, taken in 1878, to change Antwerp from a fortress to a fortified position by the construction of an outer line of 15 forts and batteries at a distance varying from 6-9 m. from the enceinte was nearly completed at the outbreak of the World War in 1914. A proposal to connect the two banks of the river by a tunnel under the Scheldt was about to be taken in hand in 1921.

On Aug. 17 1914 the Belgian Government left Brussels for Antwerp, and the Belgian army withdrew before the advance of von Beseler's army behind the fortified lines. The bombardment of Antwerp began on Sept. 28 and lasted until Oct. 9, when the city surrendered. Nine-tenths of the population fled, mostly to Holland. Some 300 houses (especially in the Marché-aux-Souliers, the Avenue d'Amérique and the suburbs near the forts) were destroyed, but the older and more important public buildings (the positions of which were known to the Germans) escaped damage. Under the harsh occupation of the Germans, Antwerp remained practically a dead city. On Nov. 19 1918, the King and Queen of the Belgians entered the city in state and attended a Te Deum in the cathedral. In Aug.-Sept. 1920, the Olympic Games (7th Olympiad) were held in a newly constructed stadium at Beerschot just outside the city.

#### THE SIEGE OF 1914

In the middle of the 19th century, the steady development of the city and its naval installations had made it necessary to enlarge the fortress, and so disquieting were the ambitions of the new French Empire that it was decided to erect a national keep for the defence of Belgium at Antwerp. The new fortress was accordingly built between 1859 and 1870 under the direction and after the plans of the celebrated Belgian engineer, Gen. Brialmont.<sup>1</sup>

It comprised: (1) A line of detached forts (forts No. 1 to No. 8 and Fort Merxem on the right bank; Forts Cruybeke, Zwynadrecht and Ste. Marie on the left) placed at a distance of about 2½ to 3 m. from the agglomeration of buildings, so as to protect these against bombardment. These forts, about 2,200 yd. apart, built both in masonry and in earth, were big batteries which embodied the lessons of the siege of Sevastopol. (2) A polygonal enceinte carried round the edge of the city.

With over 1,000 guns the entrenched camp of Antwerp was considered the most powerful fortress in the world. After the lessons of the sieges of 1870-1 and 1877, however, it was considered necessary to extend the fortress's sphere of influence still further, in order to facilitate the operations of the Belgian army when manoeuvring under its protection, and especially to enable it to make sorties in the direction of Brussels or in that of Louvain without being cut off. As the water-line formed by the rivers Nethe and Rupel considerably impeded such operations between Lierre and the Scheldt (that is to say, on that part of the front which was most convenient for them), the forts of

<sup>1</sup> A general plan of Brialmont's fortress and details of its enceinte will be found in 10.693-694.

Waelhem and Lierre and the Chemin de Fer redoubt were constructed S. of the Nethe as a sort of bridgehead. Meanwhile the demands of the port were growing, and the city was becoming cramped within its enceinte. It was therefore decided about 1900 to extend the defensive system still further.

The scheme adopted by the legislative chambers in 1906 provided for:—

(1) The creation of a *principal line of defence*, composed of detached forts about 5 to 11 m. from the limits of the Antwerp agglomeration, to shelter the city from bombardment by the artillery of that epoch. This line was, on an average, about 2 m. in front of the Rupel-Nethe water-line, thus placing the crossing points of this line out of reach of heavy field artillery. Its total perimeter was 59 m., 46 m. on the right bank and 13 m. on the left, of which 6 m. were protected by inundations.

The forts, 17 in number, were disposed about 3 m. apart, and, in principle, permanent redoubts were to be built in the intervals. The forts were armed with one or two cupolas for twin 15-cm. guns, two cupolas for single 12-cm. howitzers, and four or six cupolas for single 7.5-cm. guns. The redoubts had only one 7.5-cm. cupola. Forts and redoubts were constructed entirely of ordinary concrete, with vaults 2-50 metres thick at the crown and surrounded by wet ditches, 33 ft. wide. They all had *traditores* or "Bourgeois casemates" flanking the intervals with 7.5-cm. Q.F. guns. The garrisons varied from 100 to 500 men.

(2) The creation of an *enceinte de sûreté* on the old fort line, the forts being organized for small weapons. Concrete redoubts were built at intervals of about 500 yd. and all these *points d'appui* were connected by a grille. This line of defence was to be 20 m. long and 5 to 7 m. removed from the first line of defence.

(3) The demolition of the elaborate enceinte built in 1859 in the immediate vicinity of the town.

(4) Additional defences on the Lower Scheldt, including several coast batteries level with Doel to sweep the reaches of the river up to the Dutch frontier.

These very extensive works had necessarily to be spread over several years, and in 1914, on the outbreak of hostilities, the transformation of the fortress had not been completed.

(1) Even if the organization had been carried through according to plan, the fortress would not have come up to the standards established by the siege of Port Arthur. The two positions of defence were too shallow in themselves and also too far apart to support one another. The *points d'appui* of these positions, in which the elements of permanent defence were concentrated: on a small ground surface, very easy to locate, were conceived on a vicious principle. Monolithic concrete is not invulnerable to present-day siege artillery; the organs of defence should therefore be protected above all by their dissemination, by camouflage and by their irregular dispersion over a large surface on the principle of the Metz *Feste*.

The substructures and the armouring, constructed to resist the 21-cm. mortar, were not calculated to face 28-cm., still less 30.5 and 42-cm. projectiles.

(2) In July 1914 not one of the forts planned in 1906 was finished. Some lacked cupolas. Others had cupolas without concrete aprons, and these had to be improvised by pouring gravel, iron rods and cement round the cupolas. In some cases sacks of cement soaked with water, or even simple sandbags, had to suffice.

The transmissions and canalizations were not established either inside or outside the forts, neither was the machinery in place.

(3) For reasons of economy the 15-cm. cupolas had been provided with old guns, formerly on wheeled carriages, which had a range of not more than 3,800 yd. and used black powder. The most recent guns, amongst them those of the *traditore* batteries, hastily installed, were for the most part without the laying instruments. Of the other guns available, the most powerful was the 1889 model 15-cm. which had a range of 11,000 yards.<sup>1</sup> Older guns or howitzers, of 12 or 15 cm. were also available, all using black powder. England sent six 4.7 Q.F. guns, mounted on armoured railway trucks, and, in the last days of the siege, six 6-in. guns. No equipment for observation of fire and no observation posts existed, and the necessary survey work for firing by the map was incomplete. There were ten aeroplanes and one balloon for the fortress and the field army together.

The supply of ammunition was extremely modest, the 15-cm. guns being provided with 800 rounds, the others with only 125. Some French ammunition was hurriedly obtained, but, not being designed for the guns, it speedily put them out of action.

(4) The fort garrisons were chiefly of the oldest classes. The Lebel rifle with which they were armed was strange to them and they were entirely ignorant of the machine-gun. The men of the fortress battalions which garrisoned the intervals had had no military

service for 10 years or more and their fighting value was very low. The cadres were entirely inadequate.

Unfinished works, conspicuous and concentrated, proof only against projectiles of 21 cm.; obsolete artillery, lacking in observation-posts and in munitions; a garrison full of goodwill but with inadequate cadres and untrained in the handling of modern weapons—such were the real means of defence of the legendary fortress of Antwerp in 1914.

None the less the Belgians displayed, from the moment when their territory was invaded, the utmost activity in preparing it. The unfinished forts were put in a state of defence by any means that came to hand. The aprons for the cupolas were banked up as best they could be. Distribution systems were created for motive power, lighting and telephones. The immediate foreground was cleared, though this did more harm than good, as it made the works very visible. The inundations were prepared. Forts and redoubts were united by continuous wire. In the rear infantry trenches were constructed, but these inevitably showed well above ground on account of the water-level in the soil, and the shelters, which were none too numerous, were made merely with logs. The reserve artillery of the fortress was established in battery positions, which gave an average of five old-pattern guns, firing black powder, per km. of front.<sup>2</sup> A supporting position along the whole length of the Nethe was put in hand. The old fort line, and even the enceinte (which had been only partially demolished), were also organized as far as possible.

The unfinished state of the fortress and the mediocrity of its armament formed a serious handicap to the important part which Antwerp was destined to take in the operations.

(1) As a great commercial metropolis, always abundantly supplied with products of all kinds, Antwerp was an obvious centre for military depots and stores. Containing all the army's arsenals and supply magazines, it was a base of operations from which the army could under no circumstances allow itself to be cut off.

(2) By reason of its situation Antwerp offered to the Belgian field army a stronghold from which it could rally forth at any time it chose, to threaten the lines of communication of the German armies operating in the north of France.

(3) Through Ostend and Zeebrugge Antwerp had easy means of communication with England. Under the shelter of the fortress and the Scheldt English troops could safely land in Flanders, act in liaison with the Belgian army, operate against the German lines of communication, protect the Pas de Calais coast with its sea traffic, vital to England, and prevent the Allied left wing from being turned and enveloped.

To fulfil these important missions the fortress should have been complete and well manned. Failing these two conditions, it was of no importance save for the presence of the Belgian field army within its walls.

The Belgian army had fallen back in the direction of Antwerp when, to avoid envelopment by the German I. and II. Armies, the Nethe position had to be evacuated (Aug. 18-20). Hence, too, after the sortie battles of Aug. 25 (Eppeghem, Hofstade, Werchter) and Sept. 9-12 (Aerschot, Haecht, Louvain) undertaken for the purpose of co-operating in the battle of the Frontiers and that of the Marne, the army returned in each case to the fortress, resolved to stay there as long as its communications with the sea were not in danger.

When the German I. Army wheeled through and past Brussels on its way to France, it dropped the III. Res. Corps (v. Beseler) to face northward as a flank-guard against the Belgian field army at Antwerp. With some additions and changes, Beseler's force<sup>3</sup> remained on the defensive, fulfilling this duty on the line Grimbergen-Over de Vaert-Aerschot.

On Aug. 25 and again on Sept. 9 it had to meet serious sorties of the field army in Antwerp, and on the second of these occasions its situation was at one time critical. After this, for a few days, the front was quiet. But towards Sept. 20 reports began to come in of important German transport moves and of a quantity of very heavy artillery moving on the roads leading

<sup>1</sup> Twenty-eight cm. howitzers were used by the Japanese at Port Arthur 1904-5. The first German model of 30.5-cm. siege howitzer was designed as early as 1893.

(C. F. A.)

<sup>2</sup> Its 3½-inch shell was powder-filled. An order for 8,000 H.E. shells had been placed in Germany in 1912, but the firm concerned failed to deliver them.

<sup>3</sup> The artillery of the field army of course excluded.

<sup>4</sup> Till Sept. 8 Beseler remained under command of I. Army. From Sept. 8 to Sept. 10 his force was under the VII. Army headquarters. Finally on Sept. 17 the force was designated "Armeegruppe Beseler".

(C. F. A.)



# ANTWERP

from Maubeuge to the region N. of Brussels. The powerful *matériel* which had laid in ruins the forts of Liège, Namur and Maubeuge in succession was in fact now on its way to Antwerp. Soon it was established in position in all the region between the Dyle and the Grande Nethe, from Boortmeerbeek to Heyst-

op-den-Berg.<sup>1</sup> The heaviest ordnance, 30.5-cm. and 42-howitzers, had not only demolishing but also ranging post. They could install themselves in perfect safety beyond the treme range of the Belgian guns, and regulate their fire at on the experimental range.



**SIEGE OF ANTWERP, 1914**  
Positions of the defence and of the attack Artillery

**German Siege Artillery**  
 + Lines of medium and long artillery deployment  
 ○ 42 cm batteries (retired a bit to save successive positions of same battery)  
 ○ 30.5 cm  
 --- Original lines of fire  
 - - - Subsequent lines of fire

**Belgian Defences**  
 --- Lines of defence (defined by the wind)  
 ◆ Permanent works  
 ○ Redoubts in inner line  
 ⊕ Coast defences

**The total artillery strength of the Germans before Antwerp was:**

<b>Field Artillery</b>	F. Gun 25 batteries	150 pieces
	F. How. 6 "	36 "
	<b>Total</b>	<b>186 pieces</b>
<b>Heavy Field and Siege Artillery</b>	10 cm. 6 batteries	94 pieces
	13 cm. 4 "	16 "
	15 cm. 2 "	8 "
	<b>Long guns</b>	<b>48 pieces</b>

<b>Howitzers</b>	15 cm. 18 batteries	72 pieces
	21 cm. 12 "	48 "
	<b>Howitzers</b>	<b>120 pieces</b>
<b>Super-heavy Howitzers</b>		
German and Austrian	30.5 cm. 4 batteries	9 pieces
German	42 cm. 2 "	4 "
		<b>13 pieces</b>
		<b>(C. F. A)</b>



On Sept. 27 the German operations assumed the character of the beginning of a siege. The town of Malines received a violent bombardment and was evacuated. The artillery deployment of the attack was completed, and fire opened on the 28th.

The Army Group Beseler comprised at that time the 37th Landwehr Bde. between Alost and Termonde, where it had served in flank guard since Sept. 14; the 4th Ersatz Div. (arrived from Lorraine on the 26-27) between Termonde and the Willebroeck canal; the Marine Div. between this canal and the Dyle about Malines; the III. Res. Corps from the Dyle to the Antwerp-Aerschot railway (5th R. Div. on left, 6th R. Div. on right), and the 26th Landwehr Bde. N. of Aerschot, with a group furnished by the III. Res. C. further to the right front at Westerlo.

The specialist troops, besides the medium and heavy artillery already alluded to, were two regiments and some additional units of pioneers, four railway companies, three kite balloons and a flight of aeroplanes, a survey section and two searchlight sections. General von Beseler himself was an engineer general and had been inspector-general of pioneers.

Field-Marshal von der Goltz, Governor-General of Occupied Belgium, had at his disposal some brigades, of which the 1st Reserve Ersatz Bde. and the 1st Bavarian Landwehr Bde. joined the Beseler Group directly, while the 41st Landwehr Bde. watched the left rear between Alost and Ninove, and the 38th Landwehr Bde. the right front near Beverloo Camp.

*Siege Operations.*—It at once became clear that the attack was being concentrated on the south front of the fortress. The attack project elaborated by the Germans in peace-time had made the east front the objective. On the other hand, an attack against the west front would have had the advantage of isolating the Belgians from Allied support. But von Beseler had not the necessary forces to prosecute a siege on this side while still covering the communications through Brussels against a sortie. In spite, therefore, of the fact that the Nethe and its inundations lay behind the fort line, he had decided to attack the south front.<sup>1</sup> Trusting in the thrice-proved powers of his weapons of attack, he set out to spare his infantry, to crush and throw into confusion the lines of defence by gunfire, ruin the mechanism of the organs of defence in the forts by methodic hammering, controlled by aircraft, destroy the guns in their cupolas and the garrison in their shelters—more certainly than would have been possible if they had been dispersed—before giving them a chance of fighting. These results attained, he would then cautiously advance his infantry and gain a footing in the shattered forts and pulverized lines of defence.

The Belgian troops were thus faced with the prospect of waiting stoically and in obscurity, without hope of riposte, under the fracas of a cyclopean bombardment, till the moment when they should be blown up or crushed at their posts.

Under such conditions they could not hold out very long. It was essentially a question of the number of mortars and the quantity of munitions possessed by the assailant and of the destructive power of each separate projectile. Actually this unequal struggle lasted 10 days and nights without truce, and this time was infinitely precious in retarding the moment when the Germans—rid at last of the menace of the Belgian army on their right rear—could freely and with better chances renew their great effort to reach and envelop the left flank of the Franco-British armies.

On Sept. 27 the Belgian field army was distributed on the most dangerous sectors as follows: The 1st and 2nd Divs. between the Senne and the Nethe from Willebroeck to Lierre with the 5th Div. in reserve N. of the Nethe; the 6th and 3rd Divs. between the Senne and the Scheldt; the 4th Div. at Termonde and the cavalry division about Alost-Wetteren to cover the communication between Antwerp and the sea.

On the morning of the 28th the German cannonade was let loose along the whole front between Termonde and Lierre. Under

<sup>1</sup> His request for additional forces wherewith simultaneously to operate west of the Scheldt was refused by headquarters.

cover of this the infantry got into contact with the outposts of the fortress. The Belgian guns replied with vigour.

Between the Scheldt and the Senne Belgian detachments energetically repulsed their assailants (4th Era. Div. and Mar. Div.), notably on the outskirts of Blaesveld (S.E. of Fort Breendonck). But E. of the Senne towards noon, the super-heavy artillery came into action and began by engaging Forts Waclhem and Wavre Ste. Catherine.<sup>2</sup> At Fort Wavre Ste. Catherine the first 42-cm. shell pierced a concrete vault 2½ metres thick. At 1 P.M. the gallery of the gorge front was demolished. Other vaults, including those of the fire-control room, suffered the same fate; a cupola was jammed, and the left traditore battery crumbled into the ditch. The other forts suffered less. The firing, after a pause in the evening, continued with intensity all through the night on most of the forts. On the 29th, W. of the Senne renewed attacks, especially heavy about Blaesfeld, were repulsed. Between the Senne and the Nethe the cannonade was even more violent than on the previous day, both the trenches in the intervals and the permanent works being engaged. From 5 A.M. Fort Wavre Ste. Catherine (which in fact was the point selected by von Beseler for the break-through) received 42-cm. projectiles at regular intervals of seven minutes, not counting those of 21 and 30·5 cm.

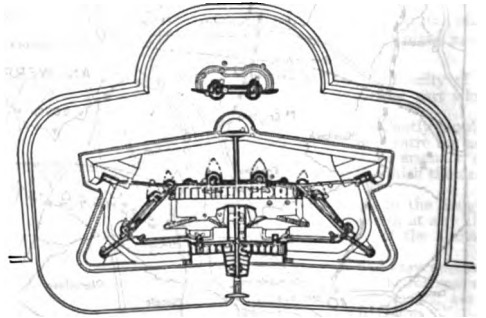

PLAN OF A FORT AT ANTWERP  
SHOWING ALL HITS OF CALIBRES ABOVE 21 CM.  
● = HITS

It is difficult to imagine the terrible situation of a garrison subjected to such a bombardment. The arrival of a 42-cm. projectile is announced by a deafening roar. When it bursts in the masonry the whole mass of the fort shakes violently and seems to sink in the earth and to oscillate back to its original level. The blast throws men against the walls. Poisonous fumes and clouds of cement dust cause violent sickness and sometimes suffocation. Under such conditions, and in close confinement, it is easy to see why the men lost not only their powers of action but even, it seemed, their reason.

The men's quarters were destroyed, fires broke out, the air became unbreathable and the greater part of the garrison took refuge on the berm of the ditch. A 42-cm. projectile went through the dome of one 15-cm. cupola, exploded, and tossed the voussours to a distance of about 30 feet. The second 15-cm. cupola was put out of action by a 30·5. The other cupolas were either destroyed by being laid bare or made inaccessible by the obstruction of their galleries. One magazine was hit by a shell and blew up. The double caponier of the capital was completely ruined.

By 11 A.M. the fort had all its guns out of action and all means of defence destroyed. The survivors of the garrison were authorized to evacuate it as fire rendered it untenable. Forts

<sup>2</sup> The artillery of medium and heavy calibre was deployed mostly along the Malines-Heyst-op-den-Berg road, the rest behind Malines, at ranges of 3,500 to 7,000 yd. from the two first and 5,000 to 9,000 from the two last-named forts. Of the super-heavy artillery two 30·5-cm. batteries (range 9,500 and 10,500 yd.) engaged Fort Waclhem and Chemin de Fer or Duffel redoubt; a 30·5 battery (8,500 yd.) and a 42-cm. battery (11,300 yd.) attacked Fort Wavre Ste. Catherine; an Austrian 30·5 battery (range 8,800 yd.) Fort Koningshoyck, and a 42-cm. battery (range 9,000 yd.) Fort Lierre. All these were two-gun batteries except the Austrian, which had four. The ranges here given are approximate. For positions see map. (C. F. A.)

Waelhem and Koningshoeyck, less heavily bombarded, continued to reply vigorously.

On the 30th the situation grew worse. The 1st Div. deployed between the Heyndonck inundation and Fort Wavre Ste. Catherine was worn out by three days of bombardment and had to abandon its ruined entrenchments and transfer the defence to the N. bank of the Nethe, leaving Fort Waelhem to defend itself in isolation. The right of the 2nd Div., affected by the retreat of neighbouring troops, and itself heavily engaged, gave way at one time.

The German infantry had not yet attacked<sup>1</sup> at any point, but all the works had suffered terribly except Fort Lierre. The artillery both of the forts and of the intervals maintained the struggle all day against the German gunners. Between the Senne and the Scheldt two powerful attacks on Blesveld and on the sector of the 6th Div. were repulsed.

The Germans, expecting that by this time Fort Waelhem, Fort Wavre Ste. Catherine, and the defences to the N.E. would be "ripe for storming," had fixed Oct. 1 as the day for their break-through. Accordingly the Marine Div. was to attack Fort Waelhem, the trenches adjacent, and Chemin de Fer redoubt, and the 5th Res. Div. to storm Fort Wavre Ste. Catherine and the Dorpveld redoubt. The attack of the Marine Div. failed to reach Fort Waelhem (the Belgian 1st Div. having largely reoccupied the trenches evacuated the day before), but its right captured Elsestraat, and after a sharp initial repulse the 5th Res. Div. reached its objectives, while the Belgian 2nd Div., after prolonged resistance under bombardment, began retreating to the Nethe.

Meantime the works of the Senne-Nethe sector had been subjected to a final and terrible hammering. Fort Waelhem had been mortally wounded. A 30.5 projectile blew up a magazine killing or grievously burning a hundred men who were sheltering in the adjacent postern. But the fort still claimed to be in a condition to fire, and, in fact, the assault on this fort was a definite failure, as also was an attempt made in the night of the 1st-2nd. Fort Wavre Ste. Catherine was carried by the German infantry in the evening of the 1st.<sup>2</sup>

The Dorpveld redoubt had been bombarded intermittently on the 29th and 30th, and on Oct. 1 from 8:30 A.M. Towards 3 P.M. an assault was delivered. The only 7.5-cm. cupola being out of action, the survivors of the garrison held the rampart for half an hour, then abandoned the firing crest and took refuge underground; a company of the enemy's infantry installed itself in the mass of the cupola and the craters of the earthwork, but the garrison kept up rifle-fire from the barrack windows.

The commandant of the work managed to get a friendly field battery outside to sweep with shrapnel the enemy installed over his head; reciprocally, his own traditore battery came into action about 11:30 P.M. to defend the interval. On the 2nd, towards 3:30 A.M., on their side, the Germans attacked the roof of the fort by mining, and the concrete, which was of poor quality, began to yield in the right-hand part of the work. From this point the artillerymen could be of no use, and they were withdrawn under cover of darkness one by one, under the fire of a German machine-gun on the redoubt. Towards 5 A.M. a second mine, still more powerful, breached the vaulting, and the enemy took possession of the deserted floor. After defending for some time an improvised barricade which limited the assailants' progress, the commandant and 12 men, the sole survivors, were forced to surrender about 6 A.M. Fort Koningshoeyck, though violently attacked by 30.5's, took a vigorous

<sup>1</sup> In its methodical advance it had reached the line of the Vrouwenvelt (Marine Div.); a line 700 yd. from Fort Wavre Ste. Catherine (5th Res. Div.); Wavre Notre Dame and Koningshoeyck (6th Res. Div.); Berlaer (37th Lw. Bde.). On the 30th the Germans were very anxious about their right flank, owing to Belgian activity in the region E. of Fort Kessel. (C. F. A.)

<sup>2</sup> According to the German account the light flanking guns were still in action when the fort was stormed. Authority had however been given to the commandant (see above) to evacuate it. The fort received 40 hits (out of 500 rounds fired) from super-heavy calibres. Observation difficulties, due to the country, seem to have made control of fire unsatisfactory. (C. F. A.)

part in the evening in repulsing the attack on the intervals.<sup>3</sup> Fort Lierre, after six hours' uninterrupted bombardment from the 42's, repulsed an attempted assault early in the evening. The same night (1st-2nd) the Germans tried in vain to pierce the interval between Fort Lierre and the Tallaert redoubt.

Between the Scheldt and the Senne the German infantry made no move on this day. The artillery, however, kept up a continuous hammering on the front of the Belgian 3rd and 5th Divs., and especially on Fort Bredonck.

On Oct. 2 the Belgian 1st and 2nd Divs. crossed the Nethe and pushed forward to regain the intervals lost during the night, but were checked by violent artillery fire, and King Albert therefore decided to transfer the defence to the north of the Nethe, and had all crossings destroyed.

The evening was marked by the death-struggle of Fort Waelhem. Here the recent strengthening of the structure had consisted chiefly in overlaying one metre of concrete on the old brickwork of 1881, and, according to the Germans, the 21-cm. shell falling in large numbers on the fort contributed as much to its ruin as the 30.5's of which calibre the fort received 30-effective hits out of 556 fired. The Tallaert redoubt and Fort Koningshoeyck were evacuated, being in ruins, the first-named owing to the explosion of a magazine, the second owing to the havoc of the shells. On the fall of Fort Wavre Ste. Catherine the 42-cm. battery hitherto engaged against that fort was turned on to Fort Koningshoeyck, superimposing its effect on that of four Austrian 30.5's. At Fort Lierre, after the fruitless attack of the previous day, the German artillery opened fire at 7:30 A.M. and battered successively all the organs of the fort. Several aeroplanes aided in directing the fire, and here the single 42-cm. battery engaged obtained a higher percentage of hits than elsewhere (32 out of 175 rounds). All the cupolas were put out of action, and all the chambers had to be evacuated in turn. By 5:15 P.M. the fort was practically destroyed and shortly afterwards it was evacuated. The Germans did not occupy it till next day.

On the 3rd the small Duffel (Chemin de Fer) fort, armed with six 5.7-cm. cupolas, on which the German artillerymen no doubt disdained to waste a 42's held the enemy engaged the whole day until its munitions were exhausted. The commandant then blew up his defences and brought back his gunners and his wounded to the N. bank of the Nethe. The German infantry of the Marine Div., which advanced during the day and the night, occupied the ruined redoubt early on Oct. 4.

The Belgian troops now began to be seriously disheartened. The forts, in which their confidence—though misplaced—had been supreme, had in a few days been shattered under their eyes by the blows of a monstrous artillery, and they knew that their field artillery had nothing<sup>4</sup> but its own brave audacity with which to carry on the struggle. All its efforts were concentrated on thwarting the enemy's active preparations for crossing the Nethe, where the infantry hastily erected new lines of defence.

The events of these days had left no illusions as to the fate in store for Antwerp's fortified positions. It had been proved that the 42-cm. or even the 30.5-cm. shell would pierce a non-reinforced concrete vault of 2½ meters or the 24-cm. (9½ in.) chrome-nickel-steel domes of the cupolas. Once fire had been opened on a fort it was a question not of days but of hours to put it completely out of action. This being so, the idea that the entrenched camp of Antwerp could constitute a definite place of refuge for the army and the Government had to be abandoned once for all, on pain of involving the army in the surrender of the fortress. But another and a far more serious

<sup>3</sup> According to the German account, the defenders were even able to counter-attack on this part of the line.

<sup>4</sup> Tschischwitz says that the existence of the Tallaert redoubt came as a surprise to the Germans. (C. F. A.)

<sup>5</sup> After the ruin of Fort Waelhem, however, a 30.5-cm. battery was switched on to the redoubt, against which it fired 127 rounds. (C. F. A.)

<sup>6</sup> Ammunition supply had become a matter of anxiety by the evening of Oct. 3.

menace threatened the army more and more as the days went on. For a fortnight past the "Race to the Sea" had been in progress in France. Each side, hoping to envelop the outer flank of the other or seeking to protect its own flank from the same fate, was being led by a series of parallel and practically synchronous efforts to displace the centre of gravity and the decisive point of the campaign towards the sea. Thus by the end of Sept. the battle-front had been extended from the Oise to Arras and Béthune, and fresh German masses were traversing Belgium in a westerly direction.

The real peril to which the Belgian army was exposed lay in the possible failure of the Allied left to gain on the enemy's right and join up with the Belgians on the Scheldt. Yet this junction must be effected at all costs, even if the fortress had to be abandoned in order to get into contact with the Allies.

The King was strongly in favour, however, of holding the fortress until the last extremity, in order to bind the troops and material now concentrated before it, and also to gain the maximum of time for the formation of a Franco-British-Belgian front on the Scheldt and the Dendre—the natural rampart of the coast, the Straits and England. To prevent the Germans from reaching the coast would be an inestimable service rendered to the Allies, and the King was determined not to relinquish the idea save in the last resort. Every day gained at Antwerp meant a French port saved—to-day Boulogne, the next day Calais, the next Dunkirk—and the withholding from the Germans of the Straits of Dover, the most important maritime artery in the world.

Mr. Winston Churchill, then First Lord of the Admiralty, fully realized the capital rôle which the fortress might play in the war. With great foresight and initiative he had drawn the attention of the British War Office to the strategic importance of Antwerp in the beginning of September. In the first days of Oct. he came in person to the besieged fortress to take stock of the situation. The Belgian Command gave him a frank statement of its intentions, and King Albert informed him personally of the rôle he proposed for the Belgian army on the extreme left wing of the Allied front. Being entirely in agreement, Mr. Churchill returned in all haste to London to push forward the immediate dispatch of all the troops the French and English Governments could spare to Antwerp and Ghent. It was urgently necessary (1) to guarantee the effective union of the Belgian army with the general Allied front and (2) to bring about this union on a level with Antwerp, or, failing this, on a line as far east as possible with its left resting on the Dutch frontier or the coast, so that the enemy could in no case seize and envelop the Allies' extreme left wing.

Given the double aim which the King had in view, that of holding Antwerp as long as possible and not allowing himself under any circumstances to be cut off from the Allies, there was no time to be lost in transferring the main base of supplies from Antwerp to Ostend, whence the army could carry out its subsequent operations in concert with the Allies. The transport of materials and supplies and the evacuation of the manufacture and storage establishments, of the wounded, the prisoners and the recruits therefore commenced on Oct. 1. Although the only through railway connexion between the E. and W. banks of the Scheldt was that by way of Willebroeck, Puers and Tamise railway bridge, within range of the enemy's guns, the trains followed one another night after night, with all lights out, until Oct. 7 without attracting attention. West of the Scheldt the evacuation transports and convoys were protected by the 4th Div. round Termonde, and the Cavalry Div. round Wetteren.<sup>1</sup>

<sup>1</sup> A first attempt on Termonde had been made on Sept. 26 by the 37th Landwehr Bde. advancing from Alost down the left bank of the Dendre. Not only had this been hung up at Gysegem, half-way, but Alost itself in its absence had fallen to an attack by Belgian forces from Wetteren. The 27th and 28th were taken up in recapturing Alost, which was thenceforward held, though the garrison was "constantly and severely worried by cavalry, cyclists, armoured cars and armoured trains" in the words of the German account. A detachment of the brigade was sent up to watch the S. side of Termonde, and one from the 4th Ers. Div. was similarly posted (next

*British Assistance.*—The immediate result of Mr. Churchill's personal intervention was the arrival at Antwerp, on the evening of Oct. 3, of a brigade of 2,000 men of the British Royal Naval Division. The apparition, at dawn on the 4th, of these the first Allies the Belgian soldiers had set eyes on during the two months of the war—aroused a wholesome enthusiasm among the dispirited defence troops. Unhappily, this assistance could be no more than a moral stimulus for a fresh burst of energy.

Meanwhile, the German infantry E. of the Senne advanced steadily as near to the Nethe line as the Belgian fire permitted, while the medium and heavy artillery moved up to new positions, and the super-heavy batteries, freed by the fall of all works between Waelhem and Fort Liere inclusive, got into place to attack Fort Breendonck on the left flank and Fort Kessel on the right—three German 30·5 batteries W. of Hombeek engaging the former, and the Austrian 30·5's at Heykant and one 42-cm. battery<sup>2</sup> at Isschot the latter. On the 4th the six pieces concentrated upon Fort Kessel at ranges of 9,000–9,300 yd. quickly finished their work, the place being ruined and evacuated just before midday. It was not until the 6th, however, that fire was seriously directed upon Fort Breendonck.

Gen. von Bessler's original scheme was that each unit on the III. Res. Corps front should strive on its own account and at its own time to obtain a foothold beyond the Nethe, while the Marine Div. remained echeloned back on the left, and the 26th Landwehr Bde. advanced on the right as close to Fort Kessel as possible. The fire directed upon the half-exposed left of the 5th Res. Div., however, soon made it necessary that the right of the Marine Div. should also attempt to advance. In this it was unsuccessful, and during the 4th the whole of the 5th Res. Div. and part of the 6th could do no more than approach the water-line.

On the right of the 6th Res. Div., on the contrary, a bold advance carried the Germans into Liere, and there began in that town a prolonged and fierce struggle, the British Marine Bde. deployed along the Little Nethe and the 5th Belgian Div. on the Nethe between Liere (excl.) and Hit Ven (excl.) completely holding up both the right of the 6th Res. Div. and those troops of the 26th Landwehr Bde. which, on the fall of Fort Kessel, had pushed up to Klosterheyde.

On the evening of Oct. 5 the German force in Liere was still pinned down by the fire of the Marine Bde. Further south, under cover of a very heavy bombardment, they had succeeded in crossing the river, but were held a short distance beyond it, along the road from Hit Ven to Liere, with only precarious communications behind them.

On Oct. 6 at dawn the 5th Div. tried, by a general counter-attack, to throw the enemy back to the S. of the Nethe. But with the whole mass of the German artillery free to cover its infantry the counter-attack was foredoomed. The Belgian guns vigorously supported it, and a determined attack near Ringenhof was for a moment successful and produced a crisis in the German line. But no more could be done. The assistance of Fort Broeckhem was at an end, since on this day it was taken under fire by the 42-cms. and the Austrian 30·5-cms. which had ruined Fort Kessel and then advanced to their third positions at Vythoek and Koningshoeyck respectively. More and more German infantry was, by one means or another, got across the Nethe, and the debris of the 1st, 2nd and 5th Divs. and the English Marine Bde. fell back little by little in the afternoon

without fighting) at Baesrode. The whole force on the left was placed under the 4th Ers. Div. staff, but until the arrival of further troops from the governor-general's forces (1st Res. Ers. Bde.) nothing could be done. On Oct. 4 the arrival of these troops, behind which the 1st Bav. Lw. Bde. was also coming up, released the 37th Lw. Bde. from Alost, and an advance was made by this brigade to Schoonarde on the Scheldt, with a view to forcing the passage there and reaching Termonde from the rear. On the 4th, 5th and 6th, however, attempts to do so were repulsed by the defenders, and throughout the critical days the Germans were unable to interfere with movements in the Lokeren region. (C. F. A.)

<sup>2</sup> The 42-cm. battery which had attacked Forts Wavre Ste. Catherine and Koningshoeyck was a railway battery, and had to remain inactive for the time being. (C. F. A.)



was moving between the Scheldt and the Dutch frontier, seeking contact with Rawlinson's force and the French Naval Bde. which were collecting towards Ghent.

In the afternoon of the 7th, under instructions from O.H.L., Gen. von Beseler informed the governor of his decision to bombard the city of Antwerp, commencing at midnight, in default of previous capitulation. This attempt at intimidation had not the smallest effect upon either Gen. Deguise or on the Communal Council which, convoked by the governor, declared itself to be "willing to accept the consequences of prolonging the defence to its extreme limits," and assured him, moreover, that it never would try to influence the decision of the military authorities responsible for such defence.

The bombardment began at midnight.<sup>1</sup> It was directed especially on the gates of the enceinte. Certain quarters of the town were attacked by long-range guns. On the same night (7th-8th) part of the III. Res. Corps pushed its patrols up to the fort line of defence.

On the 8th, Gen. Paris, the English general, and Lt.-Gen. Dassin, commanding the Belgian 2nd Div., came to the conclusion that resistance to a determined attack on the following day would be hopeless. On hearing this and also that Gen. Paris, after telephonic communication with the British Admiralty, had received orders to bring away the Naval Div., Gen. Deguise at 5:30 P.M. gave up the idea of holding the fort line of defence any longer, and decided to take advantage of the night to withdraw all the troops occupying it to the left bank of the Scheldt.

The orders were:—

- (1) The British Naval Div. to cross in the night and entrain at St. Gilles Waes for Ostend.
- (2) The 2nd Belgian Div. to accompany the British Div., covering its entrainment at St. Gilles Waes against the German troops reported near Lokeren (see below), then to march westward and try to rejoin the rest of the Belgian army.
- (3) The forts still intact to defend themselves individually to the utmost.
- (4) The enceinte to be handed over to the Germans when they appeared before it, in order to save the city from unnecessary damage.
- (5) A force of some 20,000 men of the garrison troops, under Gen. Deguise himself, to hold out as long as possible in the entrenched camp formed by the Scheldt and the forts of the left bank.

These movements took place in the night of the 8th-9th without being disturbed by the Germans (who had no suspicion of them), but not without a good deal of confusion. Meanwhile the bombardment of the city continued.

On the 7th the Germans had succeeded in forcing the passage of the Scheldt at Schoonaerde. The advance was pushed to within 2 m. of Lokeren, where sharp resistance was again met. The Belgian army was in fact streaming past the front of this small force in several columns; neither side, however, was in a position to take the initiative of an encounter battle, the Germans owing to the tactical, the Belgians owing to the strategic risks that this action would have involved.

Next day the Belgian divisions, though the enemy did not know it, were past the reach of attack and in touch with the French and British forces at and north of Ghent, leaving no baggage or stragglers to be picked up, since all impedimenta had been removed in the transfer of base to Ostend several days earlier.

On the 9th, therefore, the three German brigades, now followed by the rest of the 4th Ersatz Div., struck a blow in the air, while the 1st Res. Bde. from Alost advanced on Ghent, and at Melle became involved in a very heavy fight with the French Naval Bde. and some Belgian batteries (Oct. 9 and 10). On the 10th, wheeling inwards to invest the fortress, and thus turning their backs to the Belgian field army, the five German brigades N. of the Scheldt pushed on to the line St. Gilles Waes-St. Nicolas, Kettermit. But instead of the expected main body of the Belgians they only encountered the 2nd Belgian Div., which passed under fire of their guns at Moerbeke westward,

<sup>1</sup> It was opened by a battery of 5.9 shielded guns, E. of Lierre, 16,500 yd. from the nearest point of the enceinte. Later 13-cm. batteries were also employed. (C. F. A.)

and the two last battalions of the British Naval Div., which were caught at St. Gilles Waes and forced over the Dutch frontier.

Thus did the greater part of the prey which the Germans counted on capturing at Antwerp escape them.

Meanwhile Gen. Deguise was preparing to defend the entrenched camp on the left bank of the Scheldt. But his remaining troops were of mediocre quality. The men of the fortress battalions were old, their officers few—hardly one per company—and nearly all either reserve officers or newly commissioned. The N.C.Os. were scarce and did not know their men. In fact, Gen. Deguise had 20,000 men in uniform rather than 20,000 combatants. On troops such as these the fury of the bombardment naturally had produced a great effect, and the departure of all field troops, and that of the English whom they had welcomed so hopefully, led them to look upon themselves as so many units written off. During the whole of the 8th and 9th their lines were crossed by crowds of civilians who, carting their families and their furniture and driving their live stock in front of them, filled all the roads and routes leading westward, repeating as they went the stories, a hundred times magnified, of Visé and Louvain, of Dinant and Aerschot.

The spectacle of this deplorable exodus completed the depression of the soldiers. It was no longer possible to expect this almost shepherdless flock of men at bay to defend themselves in open trenches when they had seen armour and concrete ruined in a few hours.

On the evening of the 9th Gen. Deguise, knowing that the Germans were near Lokeren and believing, through an erroneous report, that they had also crossed the river at Antwerp itself, became convinced that no further organized resistance was possible. Officers and units were allowed to leave the fortress at will and were to attempt to rejoin the field army. Many acted upon this and some succeeded, the rest taking refuge in Holland. On the 10th the general sent a flag of truce to Gen. von Beseler to enquire the conditions of surrender. But meantime the civil authorities, seeing the city to be empty of troops, had acted on their own account. The situation was grave. At about twenty points fires had been started by the bombardment. The waterworks at Waelhem on the Rupel having been in German hands for a week, the firemen could not undertake to master the flames in the fire areas. With a sudden violent wind the whole city might be set ablaze.

To save the city from a disaster, which could be of no advantage from a military point of view, the leading townsmen had sent a deputation to Gen. von Beseler to obtain a cessation of the bombardment, and on the afternoon of the 9th an agreement was signed suspending the bombardment on condition of the surrender of all the works of the fortress the following day at noon. Gen. Deguise had no choice but to ratify this agreement.

Deep as was the impression made upon the world by the fall of Antwerp, the material strategic gain to the Germans was far less than had been anticipated. Although in military stores and economic resources their booty was considerable, not only had the whole of the Belgian field army made good its escape, but not even the fortress troops were left to adorn the German triumph. As to the works which had not been attacked, they were empty and in most cases rendered useless by their commanders.

*Antwerp—Port Arthur—Verdun.*—The rapid fall of Antwerp in 1914 may seem astonishing when compared with the resistance of Port Arthur in 1904 and that of Verdun in 1916. It is necessary, however, both in appreciating the resistance of the Belgian fortress and in deducing technical lessons from the siege, to compare the conditions of the three cases in some detail.

Although Port Arthur possessed no cupolas and several of its forts were unfinished, yet the Russians had six months' leisure to prepare, not a line, but a zone of defence 3 m. deep, in which forts, trenches and redoubts formed a tangled system, cleverly applied to very difficult ground. Dug out of hard rock, these entrenchments offered an exceptionally good resistance to the engines of destruction. The artillery of the defence was ample and well distributed in the intervals. Finally, the Japanese

siege material included at first no calibres above 15 cm. It was only after two months of the attack that 28-cm. mortars were brought up. Of these the Japanese brought 18 pieces into action, and their projectiles broke through the 1-metre concrete of the permanent forts. But even so the artillery played a secondary rôle. Under these conditions the moral of the defence was bound to be excellent, and the fortress was taken by Nogi only after sapping, mining and very heavy sacrifice of life.

At Verdun the Germans used the same calibres and somewhat the same methods of attack as at Antwerp. The bombardment was to annihilate the defence, the infantry to reap the results of the bombardment, and in fact the progress made during the first days was considerable. If they failed in their undertaking it was because the French promptly brought up a great quantity of artillery and established a regular system of reliefs for the troops in line<sup>1</sup>; because the broken ground on the banks of the Meuse was favourable to the defence; because the forts had been strengthened by reinforced concrete (some of them, notably Fort Vacheraville, were entirely of reinforced concrete), and because the nature of the soil allowed the garrison to dig themselves into shelters, proof against even the 42-cm., right under the concrete masses of the forts.

In contrast to these conditions the fortress of Antwerp was built on a uniformly flat site, with water only three feet below the surface. This made it necessary to build all the fortifications above ground and to forego the advantage of deep shelter. The forts were of simple concrete, proof to 21-cm. shells at most. The whole Belgian army was in the line from the outset without hope of reinforcements, fresh artillery, or relief. Added to this, the army, which had at all costs to avoid being surrounded in the fortress, had a vulnerable flank.

It will be seen, therefore, that Antwerp, Port Arthur and Verdun represent three absolutely distinct military situations.

*German Occupation: Reconstruction of the Fortress.*—Once masters of Liège and Namur, the Germans had lost no time in repairing all the works. They restored the concreted works to their original thickness and filled up all fissures and craters. At Namur most of the cupolas were replaced, but at Liège on the contrary they removed all guns and even numerous armour parts, and proceeded to organize the forts exclusively for infantry and machine-guns. The mechanical and telephonic installations and the ventilation system were improved.<sup>2</sup> Door and window apertures were made smaller and a great number of the latter walled up.

At Antwerp, as at Liège, the Germans converted the forts into infantry works in accordance with the principles already applied at Metz. They restored the earthworks of the forts, but did not as a rule reconstruct the chambers destroyed by bombardment. Chambers not taken into use were walled up. In the intervals they maintained only the western and northern fronts. On the west front (Blasveldt-Borabem and the left bank of the Scheldt) the existing trenches were consolidated and formed into two lines joining the gorges of the permanent works. A considerable number of small concrete shelters also were built here for machine-guns or observers, and some for flanking guns. On the north front, facing Holland, from the Lower Scheldt to Fort Schooten, the Germans took pains to maintain in good order the old permanent forts and the interval trenches. The latter were made into a continuous system, generally double, with communication trenches, and concrete shelters and posts. In front were two continuous belts of wire. The flanking was ensured by the traditore batteries of the repaired works and by concrete machine-gun emplacements. This line was prolonged by an analogous organization, facing north, all along the Turnhout canal up to and including that town.

The defence system of the river as organized by the Germans consisted of the following elements (all save the last-named on the right bank): *Santissiet gun-spur* (four emplacements for railway guns on pivot platforms, two for 28-cm. guns, two for two 17-cm. guns paired; near the platforms were reinforced concrete shelters for ammunition and personnel); *Blauwagere battery* (four 12-cm. guns in separate reinforced concrete shelters); *Lillo battery* (four 15-cm. guns without overhead protection); *Liefkenshoek battery* (two 12-cm. guns in concrete shelters); *St. Marie battery* (six 24-cm. guns in casemates).

<sup>1</sup> On Feb. 21 1916 there were in the Verdun system 11 divisions. By July 1, 547 other divisions had done duty in the line, making a total of 654. Of this total on an average about 27 were present at any one time. (C. F. A.)

<sup>2</sup> Belgian and German accounts of the siege of Antwerp concur in noting the inadequate ventilation of the forts and the effects of this on their resisting power. (C. F. A.)

To sum up, the Germans in restoring the fortress of Antwerp treated the permanent works on the principles applied at Metz, and the intervals as if they formed part of an army front.

**BILGEOGRAPHY.**—The Belgian official account of the operations of 1914 appears in instalments in the *Bulletin Belge des Sciences Militaires*. An official German account (*Austrian pen 1914*) by E. V. Tschischwitz, senior general staff officer III, Reserve Corps at the siege, was published in 1921 at Oldenburg. For the British part the official naval history by Sir Julian Corbett should be consulted. (R. VAN O.)

**AOSTA, DUKE OF (EMANUELE FILIBERTO) (1869- )**, Italian general, was born Jan. 13 1869, the eldest son of Prince Amedeo of Savoy, Duke of Aosta (see 1.804), and Maria Vittoria, Princess of Pozzo della Cisterna (1847-1876). In 1895 he married Princess Helene of Orleans, daughter of the Comte de Paris. Devoting himself seriously to the military career, he in due course commanded the 1st Div. at Turin and the X. Army Corps at Naples. A very serious illness caused a break in his career, and on the eve of Italy's entry into the World War he was still on the reserve list. Following upon the clash between Cadorna and General Zuccari, who had been appointed to the command of the Third Army, the duke was chosen to succeed the latter, and he retained this post throughout the war. The duke's command of the Third Army was conspicuously successful. His task was thankless, for the duty of his army was to hammer against the iron ramparts of the Carso. Various notable successes were won, though the territorial gains were very limited, and in the process of wearing down the enemy the Third Army played a great part. The duke's rank possibly told against him to begin with; but the qualities which he showed speedily made it clear that he was no figurehead, and that he held his command by merit. In the end the fact of his being a royal prince was only a help to the position he had established for himself, for it put him outside the field of ordinary jealousies. He had the invaluable faculty of establishing harmony and a spirit of co-operation among his subordinates, and he won a great popularity among the troops, for whose welfare he did all that lay in his power. His qualities as a leader were so highly estimated that he would probably have been chosen to succeed Cadorna if it had not been thought unwise to place upon a royal prince the responsibility of so grave a moment.

The Duchess of Aosta served throughout the war as inspectress-general of Red Cross nurses. In spite of delicate health, she rose superior to continuous fatigue and frequent hardship, and the award to her of the silver medal for valour was no mere compliment. Their two sons Amedeo, Duke of Apulia (b. 1898), and Aimone, Duke of Spoleto (b. 1900), both served in the war.

**APPONYI, ALBERT, COUNT (1846- )**, Hungarian statesman (see 2.226), was from 1906 to 1910 Minister of Education in the Wekerle Cabinet. In consequence of Francis Kossuth's illness Apponyi undertook the greater part of his business as president of the party of Hungarian Independence, calling itself the party of 1848. In the message sent to the party just before his death Kossuth designated him as his most suitable successor. At the outbreak of the World War he adopted in Parliament the standpoint of a "truce of God." Together with Count Julius Andrássy and Rakovszky, Apponyi was from July 6 to Aug. 25 1916 a member of the commission established by the Hungarian Chamber of Deputies to watch over the conduct of foreign policy. In internal affairs Apponyi fought for universal suffrage. After the outbreak of the October revolution of 1918 he retired for a time into private life. In 1919 he was elected as a non-party deputy to the National Assembly, and was head of the Hungarian peace delegation in Paris. He became a member of the League of Nations Union, and as a politician standing outside party was in 1921 perhaps the most influential man in Hungarian politics.

His published works include: *Recollections of a Statesman* (1912); *Die rechtliche Natur der Beziehungen zwischen Oesterreich und Ungarn in die Oesterreichische Rundschau* (vol. xxviii); and in *Hungarian Hungary in the World's Press* (1915).

**ARABIA** (see 2.254).—The political frontier of Arabia on the N. was indeterminate in 1921 except in so far as the boundaries between Syria, Palestine and Mesopotamia, as laid down in the

Franco-British Convention of Dec. 23 1920, affect it (see SYRIA). The limits of the various independent states of the peninsula, with the exception of the N. boundary of the Aden protectorate, all remain equally undefined. A natural frontier on the N. runs in an irregular curve from Akaba ('Aqaba) first N.E. and then S.E. to the Persian Gulf, following the fringe of cultivation, which fluctuates according as the nomadic or sedentary population is the stronger. This line excludes Kerak, but leaves the transition area of the Hamad or Syrian Desert within Arabia, to which, both physically and ethnographically, it seems to belong.

**Topography.**—Up to 1914, even the best knowledge of Arabia was sketchy, but considerable advance has since been made by the discoveries of recent travellers and as a result, direct or indirect, of war operations. The progress to be noted falls under three main heads: new light has been thrown on the drainage of the peninsula; the positions of a number of places, previously very imperfectly known or only guessed at, have been accurately fixed; and a vast amount of topographic and ethnographic detail has been accumulated.

The compilation of the map of Arabia on the million scale has kept pace with discovery. For this purpose, the route traverse in northern and central Arabia from Huber's *Journal*, extending over 3,000 m., was replotted on a large scale and formed a groundwork on which to place the more hurried surveys of Wallin, Palgrave, Doughty, etc. All the labours of recent travellers, starting with Leachman (1910), and ending with Bell (1914), were reconsidered from the originals and adjusted with due regard to the proportionate value of each, while the information collected by Col. Lawrence during the World War and the surveys of Philby were incorporated. The work of compilation was undertaken by D. Carruthers in 1914 and in 1921 was still in progress. Provisional sheets covering the northern half of the country had already been issued.

The course of the main watershed of Arabia can now be traced with general accuracy. Prolonged northward from the highlands of Yemen and Asir, it passes inland between Taif and Wadi 'Uraba and runs E.—not W. as was previously supposed—of the Hejaz railway through the Kheibar *harrā*, or lava outcrop. Perhaps some of the higher peaks of the 'Aweiridh ridge overtop it.

Wadi Hamdh, the main drainage basin of the short western slope of Arabia, previously thought to have its head-waters in the vicinity of Medina, at about lat. 24° N., in all probability has its source in W. 'Aqiq, at least 3° farther S., thus giving it a total length of 700 to 800 m. including windings. The 'Aqiq, rising S.W. of Taif, passes well to the E. of Mecca and W. of Medina and is said to take the name W. Shaiba between these two towns. Some doubt remains whether the Shaiba discharges wholly into the Hamdh just N. of Medina, or whether it also forms a tributary eastward in W. Rumma (Rima). Wadi 'Ais, coming from the N., and W. Jizil from the S., and joining W. Hamdh in the plain of Jurf are its two main affluents, and their courses, together with the middle reaches of the Hamdh, have been explored in great part and mapped.

Much new information has been obtained as to the drainage of the long eastward slope—effected mainly by the great wadi systems of the Dawasir, Sahaba and Rumma (naming from S. to N.). The town of Dam, in W. Dawasir, central Arabia, previously mapped near lat. 23° N., has had its position definitely fixed in lat. 20° 27' N. and long. 44° 40' E. The direction of the course of W. Dawasir, a matter long in dispute, proves to be S.E. towards the Ruba' al Khali or Great Southern Desert, and not N.E. as the old maps show. The point of junction of the important Asir wadi—Ranya, Bisha and Tathlith—is in all probability in the plain of Hajla about 50 m. N.W. of Dam. As to W. Sahaba, which has a practical monopoly of the surface-waters of the central mass of Arabia and the drainage of which trends to the sea at the southern end of El Qatar, it was found to have its remotest head-waters in W. Sirra in the very heart of the peninsula. Under the name of W. Birk, the Sirra breaks through the Thuwaiq plateau and, turning northward as W. 'Ajaimi, joins W. Hanifa some 60 m. S.E. of Riyadh (lat. 24° 37' N., long. 46° 41' E.). W. Hanifa ultimately falls into the Sahaba, but the latter probably carries no surface-water, at any time, farther than the western fringe of the Dahana, about long. 48° E. Wadi Subai, rising somewhere in lat. 22° N., is probably the most southern tributary of W. Rumma.





**Jebel Tuwaig**, the salient physical feature of central Arabia, was found to extend for some 60 m. S. of Wadi Dawasir—much farther S. than was previously suspected—giving this crescent-shaped plateau a length from Zilfi (lat. 25° N.) of over 500 m. It has an average breadth of 20 m. and a mean elevation of nearly 3,000 ft. above sea-level and 600 ft. above the great plain on the west. The positions of the southern Nejd oases, most of which are situated on or around the Tuwaig plateau, have been ascertained; and much further light has been thrown on the limits and peculiar character of the Nejd and Dahana sand-belts on the N. and N.E. respectively, the former proving to be comparatively hard gravelly plain covered at intervals with parallel sand-belts of varying width and the latter a continuous area of deep sand forced by wind pressure into high sand billows or dunes.

**Exploration.**—The journeys of recent travellers have been mostly confined to the central and northern parts of Arabia; but a little new ground has also been broken in the W. and S.W. Some of these explorers, notably Philby, Shakespear and Bell, made route traverses by prismatic compass, checked at intervals by determinations of lat. and long. which greatly enhanced the value of their work. (See Map).

**Central Arabia.**—Foremost among the explorers since 1910 is H. St. J. B. Philby. In 1917, when on a mission to the emir of Nejd, he crossed the peninsula from sea to sea, a feat previously accomplished by only one other European—Capt. Sadlier, in 1819—his line being from 'Oqair ('Ojair) on the Persian Gulf to Jidda, by way of Hofuf, Riyadh and Taif. He attributes the exceptional fertility of the Hofuf group of oases to the reappearance at the surface there of the rainfall of a very large area. Beyond Riyadh, Philby was the first European to follow, for most of the way, the great central pilgrim route to Mecca. He passed Ghat Ghat, a centre of the Wahabist revival (see AKHWAN MOVEMENT). After 80 m. of limestone desert alternating with belts of Dahana, his route lay across the highlands of Nejd, a granitic tract 150 m. in breadth, where he found altitudes up to 3,100 ft.; this tract forms part of the great divide between the N.E. and S.E. slopes of Arabia in which, in about lat. 23½° N. and long. 43½° E., lie the head-waters of W. Sahaba. For no less than 200 m. between the small settlement of Qusuriya, long. 44° 30' E., and Khurma, lat. 22° N. long. 42° E.—a village of mud huts on the confines of the Hejaz and a point of conflict between the King of the Hejaz and the emir of Nejd—he found no settled habitations, but encountered vast herds of gazelles. After crossing the Rakba plain he reached Taif and, following down the gorge of W. Fatima, reached Jidda.

In a subsequent journey, May–June 1918, Philby explored southern Nejd, going 300 m. southward from Riyadh to Dam and back. His route outward lay through the previously unvisited oases of lowland Afaj and W. Dawasir and he returned along the crest of Tuwaig by way of highland Afaj and El Fara. He determined astronomically the positions of a number of places, including Riyadh (lat. 24° 37' N., long. 46° 41' E.), Abu Jifan (lat. 24° 29' N.), Hair (lat. 24° 21' N.), Sulaiyif (lat. 20° 25' N., long. 45° 29' E.) and Dam (long. 44° 40' E.), and ascertained various heights by aneroid readings. As a result of the journey, the hydrography of the Tuwaig plateau, the backbone of central Arabia, is now as well known as any part before the World War. Philby's estimate of the population of Riyadh is 12–15,000, and its most conspicuous buildings are the palace of the emir and the great Wahabi mosque. The oases of Nejd were found to comprise, usually, a nucleus town with scattered hamlets, and not more than a few square miles of cultivated land around in each case; and populations never exceeding 10,000. Ja Afaj and Kharj he made a notable discovery of ruin fields of considerable area, scattered with stone circles varying from 10–45 paces in diameter about heaps of rubble, in the middle of which usually stand large blocks of stone resembling the bases of pillars. Situated on hillsides some distance from cultivation, they suggest burial mounds of an early era, and open up an interesting field for investigation. In both districts, the peculiar system of irrigation from natural reservoirs or deep well pits by means of subterranean channels, or *karez*, was unexpectedly found to prevail. At Umm el Jach, just S. of Laila, is a lake ½ m. by ¼ m., possibly the largest sheet of permanent water in Arabia, and also a number of reservoirs of unusual size, one measuring 500 by 600 yards. In the Makran depression, S. of Badia (lat. 22° N.), are other perennial pools of water surrounded by woods of well-grown trees. The oasis of Dam (his main objective) locally known as "the wadi," Philby found to consist of some 20 separate settlements with a total population of 9,000, mostly of negro origin or of the Dawasir tribe. Dam itself has a population of about 3,000 and owes its importance to its situation near the line of trade between Yemen, Aden, Nejrhan (seven days distant), and central Arabia.

The negative results of Philby's journeys were almost as valuable as the positive: he found that the Nejd oases are not tropical paradises; that there is no chain of oases linking Nejd with either Asir or Yemen; and that there is no region of fertility between southern Nejd and Oman, or any settled spot between it and either Oman or Hadhramaut.

**Northern Arabia.**—In 1910, Lt.-Col. G. E. Leachman set out from Kerbela for Hail (J. Shammar) and Riyadh, but, after passing Leina, he had to return to Samawa. Again, in 1912, he left Damascus intending to cross Arabia from N. to S. He got as far as Riyadh by way of Hail, Leina, and Boreida, but the emir of Nejd refusing him safe conduct, he was obliged to turn eastward and emerged by the usual road through El Hasa to 'Oqair. As a result of these journeys he drew attention to W. Khar, an important affluent of the Euphrates, and discovered its possibilities as a line of communication between Syria and Iraq via the oasis of Jauf, noting that water is obtainable at regular intervals along it. He was first among Europeans to visit the remarkable wells of Leina, of which there are several hundreds, spread over an area of 5–6 sq. m.; and he is the only European who has made any record of a journey from J. Shammar to Suq esh Shuyukh. His travels were equally important politically, for he laid the foundations of a good understanding between Britain and the emir of Nejd; he was treacherously shot, Aug. 1920, in Mesopotamia.

In 1913–4, Miss Gertrude Lowthian Bell travelled alone, except for native guides, from Damascus to the neighbourhood of Teima. Thence she passed eastwards over new ground along the southern margin of the Nejdud to J. Shammar and visited Hail; then northwards by Loqa to Nejed and Bagdad. The latter part of the route was especially valuable, as it added considerably to knowledge of a region hitherto traversed only by Wallin in 1848. Miss Bell is the only woman traveller in Arabia, with the exception of Lady Anne Blunt, and one of the few women who can lay just claim to the title "explorer," for she surveyed her route by prismatic compass from start to finish.

Capt. Shakespear, British political agent at Kuwait, who became political officer in Nejd in 1914, travelled much in northern and central Arabia. He made compass traverses of his journeys and left voluminous notes which proved of great value. In 1913–4 he crossed the peninsula from Kuwait to Suez by way of Riyadh, Boreida, Haiyaniya and Jauf el 'Amr, following an entirely new course beyond the last-named place. He was killed in action Jan. 24 1915 in a conflict between the forces of Ibn Sa'ud and Ibn Rashid whilst on special duty with the former; his death was a grievous loss to the Indian Political Service, to which he belonged, and to geography.

In 1909, Douglas Carruthers went, primarily, in search of the little known *oryx beatrix*, a rare antelope inhabiting the interior of Arabia, which hitherto had not been hunted by any European, and he obtained a complete series of skins and horns. His route, from Jiza (Ziza) in the Belqa, lay through an untramped region. Guaranani, in 1864, being his only forerunner, except at Teima. He surveyed his route southwards to Teima, thence northwards along the Nejdud towards Jauf el 'Amr, and back to Jiza.

Alois Musil, in 1908–9 and again in 1910, explored extensive tracts between lat. 27° and 36° N. and long. 37° and 44° E., embracing the Hamad, W. Sirhan, Hajara and Wadiyan. He is reported to have made plane-table surveys of parts of these regions which should furnish valuable data towards the mapping of northern Arabia; he added greatly to knowledge of its ethnography, natural history and archaeology. He is the only European who may be said to have penetrated the Hamad to any great extent.

In 1912, a journey from Kuwait through Zilfi, Boreida, and Riyadh to Hofuf and the coast again was made by Barclay Raunkiaer on behalf of the Danish Geographical Society; he made a prismatic compass survey of his route which to a small extent covered new ground. Raunkiaer died in Copenhagen, July 1915.

Capt. Aylmer and Capt. S. S. Butler, in 1907, opened up comparatively new ground between Bagdad and Jauf.

**The Hejaz.**—The Arabian section of the Hejaz railway was so ill-known before the World War that even the stations could not be enumerated correctly. Determination, in 1917, of the lat. and long. of Ma'an and the observation of the long. of a few stations to the S. enabled valuable adjustments to be made in the trace of the line. A bolt of the Hejaz slope, some 300 m. in length between Wejh and Raugh and a smaller tract, some 100 m. in length between Wejh and Akaba were, in 1864, being his only forerunner, except at Teima. He thoroughly explored as a result of war operations, and a Turkish staff map of the country within a 30-m. radius of Medina which fell into British hands added further useful data, so that a great part of the Hejaz can now be mapped with fair accuracy. Much was learnt about the Billi tribe who people the rolling country between Wejh and the railway. They were found to be pure nomads without a single settlement in their district except one small garden at El Kurr; while the Juhaina and Harb to the S. of them are less nomadic.

**Asir and Yemen.**—Towards the end of 1918, in the course of Idrisi's final campaign against the Turks, British officers could mix somewhat freely with his people on the coast and were able to meet tribesmen from the least known parts of the interior, and so an amount of knowledge, topographical, social and political, was gained. In particular, the composition and distribution of the chief tribes of Asir and Yemen was learnt. The position of Ibhā (formerly Menadhir), the headquarters of the Turks, was at long last ascertained, though no European got there even when they surrendered. Sabia, Idrisi's capital, about 23 m. N.N.E. of Jeizan, was visited by an Indian medical officer who, for the first time, was able to describe

this hut village. In Yemen, in 1909, a considerable amount of survey work was done by M. A. Beneyton, a French engineer, for a proposed railway from Hodeida to San'a and 'Amran (see below) and, as a result, much unexplored territory was mapped on a scale of 1:250,000. G. Wyman Bury went from Hodeida to San'a in 1912, and made a long stay at Menakha in the same year. He has thrown more light than perhaps any recent traveller on the topography and economic conditions of Yemen. A. J. Wavell visited San'a in 1911 and gave the best description of the city since Manzoni, 1884. He found the population reduced to 18,000 as compared with Harris's computation of 50,000 in 1891. The decline in population and the commercial depression prevalent in Yemen may be attributed largely to the lawlessness of the intractable Zaranik and Qah-tan tribes who occupy the country between the highlands and Hodeida.

*Aden Protectorate and Hadhramaut.*—There is little new information regarding these districts. Bury, in 1911, described his penetration of the Kaur watershed (alt. 7-9,000 ft.), N. of the Yafa' Fadhli country. He visited Yeshbum (pop. 4,000), the capital of the Upper 'Aulaki, situated in a plain producing cotton and indigo and carrying on an industry in cotton fabrics, and got as far as Beihan, 110 m. inland of Shughra and almost in touch with Mareb. *The Red Sea Coast.*—The naval patrol during the World War added much to knowledge of the very intricate coastline from Akaba to Aden. The triple coral reef fringing it had kept this coast almost inviolate, but the very numerous openings through the reefs are now known and have been charted.

*Political History.*—Before the World War, the Porte claimed control of Arabia in its entirety as rightfully part of the Ottoman Empire in virtue of the Sultan's authority as caliph. In actual fact, most of the peninsula was under a number of independent native rulers, only some of whom acknowledged Ottoman influence, and that to a limited degree, while others were under British protection. Effectual Turkish jurisdiction was confined, in the Hejaz, to the two Holy Cities, their ports, and the line of railway; in Asir, to one or two small ports and the inland districts of Isha and Muhail; and, in Yemen, to certain garrisoned towns in the interior and to the ports of Hodeida and Mocha and connecting roads. The Hejaz railway, built nominally for the benefit of pilgrims to Mecca but in reality to increase the Ottoman hold on Arabia, did not fulfil political hopes, partly because it served not more than a third of the territory that the Turks claimed and partly because of the immense difficulties of its maintenance and working; and it brought about little or no economic development in the peninsula.

The World War marked the passing of Turkish control from the whole of Arabia and, at the opening of 1921, there existed the following principal autonomous elements: the kingdom of Hejaz; the emirate of Nejd and El Hasa; the emirate of Jebel Shammar; the principality of Sabia in Asir; the imamate of Yemen; the sheikhdoms of Kuwait, of Bahrien Is., and of El Qatar; the Trucial Oman; the sultanate of Muscat in Oman; the Ka'aiti and Kathiri sultanates of Hadhramaut; and the autonomous tribes under treaty with Aden. But this list does not exhaust the autonomies, for there are many tribal communities—settled, half-settled and nomadic—which owe allegiance to none but their own local chiefs, such as certain sections of the Anaza and Muntefiq in the N. and the Zaranik and Yam in the S. The parcelling of the peninsula among so many separate communities is largely the result of peculiar geographical conditions which hardly admit of homogeneous settled life except in certain favoured districts, or in oases or wadis; and it is only by virtue of some peculiar source of wealth, some common spiritual ideal or some external support that larger-territorial dominions have been established.

*The Hejaz.*—War with Turkey entailed on Great Britain and her Allies certain dangers in Arabia owing to the efforts made by the Central Powers, through the Porte, to arouse Moslems to a *jihad* or Holy War. Whether this result followed or not, there was every likelihood that the Turks would try to hinder the free use of the sea route to the East and, if left in control in western Arabia, that Aden and the possessions of the Allies in East Africa and the Farther East would be dangerously accessible to the enemy. Great Britain therefore turned to the sheriff of Mecca (Husein Ibn 'Ali), believing that the metropolitan position of the Holy Cities of Islam and the venerated lineage of the sheriff would make very effective his refusal to

countenance a *jihad*, while if he declared against the Turks, the geographical position of the Hejaz would make the materialization of the other dangers improbable. Sheriff Husein was known to desire the emancipation of the Meccan emirate.

Under the Ottoman régime, the Hejaz was a *vilayet*, with a *pali* resident at Mecca. Nominally, it included all the area S. of Ma'an to Lith, and was subject to taxation; but the cities of Mecca and Medina were not only tax free but were in receipt of subsidies from the Ottoman treasury, as were also certain Harb sheikhs who were able to interfere with the passage of pilgrims or with the railway track. The whole vilayet was exempt from service in the Turkish army and successfully resisted an attempt to impose conscription in 1914. The Porte maintained forces in the Hejaz, the normal garrison being about 7,000.

Side by side with this foreign government, existed the authority of the sheriff or emir of Mecca, enjoying extra-territorial independence at Mecca and Taif with the right to keep official representatives to watch over his interests at Medina, Jidda and elsewhere. The emir was able, at need, to call out considerable levies of Hejazi and other Bedouins and, by so doing, under semblance of helping the Turks, successive emirs not only made interest with the Porte but inspired it with a wholesome respect and, at the same time, kept in touch with a fighting force which could be used some day for their own ends.

Sherif Husein was nominated to the emirate in 1908, as a man of pacific character, likely to serve the Porte's purpose. In 1910 he took up arms for the Turks against the Asiri revolt under Idrisi. In the same year he extended his influence over a part of the territory of the emir of Nejd in central Arabia. But in 1913 he began to pursue an active anti-Ottoman policy, ostensibly opposing the extension to Mecca of the Hejaz railway and supporting the Harb tribesmen in their resistance to this and other Turkish projects; and he organized the Hejaz tribes acknowledging his authority, with a view to insurrection. He reconciled himself with Idrisi and tried (without success) to get the support of the imam of Yemen in his anti-Ottoman aim; and, in 1915, he sent 'Abdalla, his second son, to bring about a truce between the emirs of Nejd and J. Shammar.

In the summer of 1915, Sherif Husein declared his desire for a revolt to the Allies, who thereupon agreed to support him with money, munitions and supplies. A long period of inaction followed, however, and it was not until June 1916 that the revolt actually broke out. After the loss of Jidda, Mecca and Taif by the Turks, Husein proclaimed himself independent of Ottoman rule June 5 1916. To explain his attitude to the Moslem world, he issued a proclamation (Aug. 1916) setting out a number of indictments against the Committee of Union and Progress; and, finding that the Ottoman Government was unable to spare any large force to oppose his aims, he was formally proclaimed "Sultan of the Arabs" in Oct., a large number of chiefs assembling in Mecca to support him. He relinquished this title for that of "King of the Hejaz" in Dec., and was so recognized by the Governments of Great Britain, France and Italy. In 1917, Wejeh and Akaba being lost by the Turks, the newly established kingdom was able to maintain its separate existence, and the year 1918 witnessed further satisfactory developments. In spite of the Armistice, the Turks refused to surrender Medina until Jan. 1919. The Hejaz was represented at the Peace Conference by the Emir Faisal, King Husein's third son, and the state was admitted a member of the League of Nations in 1920. By the treaty of peace with Turkey, that country renounced all rights and titles to the Arabian peninsula and the King of the Hejaz undertook to ensure free and easy access of all Moslems to the holy places of Mecca and Medina. The treaty had not, however, been ratified by the Hejaz at the beginning of 1921.

King Husein maintained friendly, but formal, relations with the emir of Nejd during the World War; but, in 1919 and the early part of 1920, there was frequent friction between them over the debatable border at Khurma in the neighbourhood of Taif. A battle at Turaba, near Taif, in May 1919, resulted in a loss of 4,500 men to the Hejaz army; but the emir of Nejd did not follow up his advantage. In June 1920, relations between the dis-

patents were reported to be more friendly; but the frontier still remained undefined in 1921.

*The Central Emirates.*—The emirate of Nejd, capital Riyadh, and that of Jebel Shammar to the N., capital Hail, comprise all the country between the main northern and southern deserts of Arabia. Between the two emirates lie the oases of Qasim and Sodeir, the overlordship of which has been in dispute for more than two generations. The two emirs control, more or less effectively, all the peoples both settled and nomadic of central Arabia, and the authority of the emir of Nejd extends to El Hasa on the E. and to certain tribes of the Asir border and Wadi Dawasir on the W. and S. Wahabism, or its more modern manifestation the Akhwan movement, supplies the moral basis of the power of the emirate of Nejd, while the settled nature of the population is its material basis. The emirate of J. Shammar, on the other hand, grew out of the desert power of a great nomadic society accustomed to maintain a group of permanent villages and hamlets around J. Aja and Selma, which served as rallying places and as market centres. The Shammar emirate, while inferior to its rival in wealth and settled population and lacking its religious tie, owes its strength to the unity existing between its oasis folk and the tribes of the surrounding regions, to the patriarchal tie binding them, and to the stimulus of the steppe desert upon its life.

Nejd (see 19.351) comprises all the oasis groups situated about or on the Tuwaiq plateau, extending well over 500 m. from N. to S., and is directly or indirectly under the rule of Ibn Sa'ud of Riyadh. In addition, the emir lays claim to El Hasa, on the Persian Gulf between lat. 24° and 29° N. He drove the Turks from this district—which they had occupied as a sanjaq of Basra since 1871—in May 1913, and was acknowledged by the Porte as *sahib* of Nejd and El Hasa. He, however, effectively occupies only the Hofuf group of oases, with the ports of Qatif and 'Oqair. In 1914, Ibn Sa'ud entered into relations with the British Government—Capt. Shakespear being appointed political officer in Riyadh—and proved an unswerving ally throughout the World War. He declared himself definitely against Ibn Rashid, emir of J. Shammar, who had allied himself with the Turks. He fought a drawn battle with Ibn Rashid at Mejma' in 1915, the main point in dispute being the ownership of Qasim with the towns of 'Aneiza and Boreida; it was in this battle that Captain Shakespear was killed. His attitude towards the Hejaz, while war lasted, was friendly but formal. By 1918, after intermittent and generally successful campaigns against the emir of J. Shammar, Ibn Sa'ud had established his supremacy in central Arabia, including Qasim and Sodeir. His relations with the King of the Hejaz, in 1919-20, became less cordial, frequent disputes having arisen over the frontier question. He is believed to have steadfastly refused either spiritual or temporal allegiance to King Hussein. Early in the summer of 1920, Ibn Sa'ud turned his attention to E. Arabia and instigated an attack on Kuwait, which port he is said to covet. Several actions took place but without definite result, and subsequently efforts were made on the part of the British Government to bring about a territorial agreement between the emir and the sheikh of Kuwait.

Before the World War, the authority of Ibn Rashid was supreme in the group of oases about J. Aja and J. Selma; in the steppes N. of Qasim, from the Hejaz border (including the oasis of Teima) almost to Kuwait; and in the oasis of Jauf el A'mr. On the N. and E., the southern Nefudh and the Dahana formed a neutral zone between his territory and the nomad tribes beyond. Ibn Rashid's attitude in the World War was consistently pro-Turkish, though relations between him and the adherents of the Committee of Union and Progress were probably never cordial. The comparative ease with which the Turks could reach Hail, from either the Hejaz railway (at Mu'adhdam) or from Samawa and Nejed, contributed towards making him sensitive to Ottoman pressure. He was reported to have supplied the Turks with large numbers of camels, especially for the expedition against Egypt in 1915-6. As the World War proceeded, his power diminished, both territorially and economically.

While Ibn Sa'ud was fighting the Turks in El Hasa (1913), Ibn Rashid was able to maintain his position; but, in 1915, an attempt on his part to overrun Qasim and Sodeir resulted in the loss of the towns of 'Aneiza and Boreida, and they were placed under tribute to Ibn Sa'ud. The oasis of Jauf, on the caravan road from Damascus to Hail, was seized in 1910 by the Ruweila-tribe of the Anasa under Nuri esh Sha'lan, one of the most powerful and anti-Turkish of the nomad chiefs. Nuri had shown himself a successful rival of Ibn Rashid, for, in spite of determined attempts on the part of the latter to regain the oasis (notably in 1914), he was not able to re-establish his authority in Jauf. The important oasis of Teima, also, reverted to the Hejaz in 1917. In the same year Ibn Rashid went to reside at Meflaj-Salih and, for a year, did not set foot in his capital. In May, 1920, his murder was reported.

*Asir.*—The limits of this district are indeterminate, but broadly it comprises the country lying between the territory under the jurisdiction of the King of the Hejaz—who claims control of the Tihama down to Qatif— and that of the imam of Yemen. Its eastern limit is contiguous with Nejd. There is a strong political and social distinction between the people of the Tihama lowlands and those of the highlands which constitute Asir proper; and there is no part of Arabia where the tribal elements are so sharply defined and their boundaries less changeable. Settled tribes are the predominant element in Asir, as the physical conditions favour the pursuit of agriculture sufficiently to render nomadism unnecessary. In religion, practically all the tribes are Shafei Sunnites; Wahabism has a few adherents and its tenets are regarded sympathetically all over the district; but everywhere there is a strong antipathy to Zeidism.

Asir cannot be regarded as a political entity. In 1904, it fell into four parts—sections acknowledging the Turks, the Idrisi of Abu 'A'ish, and the sheik of Mecca respectively, and small groups of nomad tribes on the E. who recognized no authority. The Turks claimed the whole of Asir as the northern section of the *wilayah* of Yemen, but never succeeded in subduing the country and, in reality, they only precariously held the inland towns and immediate surroundings of Ibbah and Mubail and the port of Qatif, all of which they garrisoned. The authority of the Idrisi was restricted to a strip of the Tihama some 60 m. long and extending about 40 m. inland to the escarp of highland Asir, with Sabia as capital and Jazan and Midr as ports. The influence of the sheik of Mecca was mostly confined to the Ghamid and Beni Shibir tribes on the inland side of the ridge.

Interest in Asir, during the World War, was centred on the Idrisi, Seyyid Muhammad. His aim throughout was to rid the district of Turkish control and to extend his own influence. By 1910, he had much reduced the Ottoman hold and, in 1911-2, subdued and supplied by the Italians during their war with Turkey, he consolidated his position. In 1912, failing to obtain sufficient recognition of his power from the Turks, he declared himself definitely against them. He concluded an agreement with the British resident at Aden in May 1915, and was supplied by the Allies with material. He raised part of the Zaranik tribe and took the field, ostensibly against the Turks, with a nominal following of some 12,000 men and overran the Tihama of Yemen, but failed to capture Lohela, one of his main objectives.

In reality, his support of the Allies was not of a very positive character, as he was in constant fear of attack by the imam of Yemen; and the Turks held Ibbah and Mubail, their strongholds in the interior, until the Armistice. He kept on good terms all the time with the King of the Hejaz. The actual extent of the Idrisi's control of Asir, at the beginning of 1917, still remained a matter of doubt; but his attitude towards the imam of Yemen continued to be hostile, though there had been short periods of truce between them. In Feb., information reached England that Idrisi forces had occupied Hodeida.

*Yemen.*—As in Asir, the social contrast between the highlands and lowlands is very marked, being the outcome of religious and racial differences reinforced by strongly contrasted geographical conditions. Broadly speaking, the central highland population is Zeidite (Shahi) and accepts the authority of the imam, whereas

the population of the Tihama and the extreme N. and S. is predominantly Shafe'i and is strongly opposed to him. In consequence there has hardly ever been any semblance of administrative unity in the province. It is difficult to state the imam's territorial title as distinct from what he claims. While the Turks were in Yemen, there were districts or tribal groups (e.g. in the Yemen interior) who repudiated them, but were not unwilling to accept an imam wholly independent of them; there were others who accepted the Turks, but would have nothing to do with the imam except under pressure (e.g. the Isma'iliya, the Daudiya sect along the Hodeida-San'a road, and most of the northern Tihama tribes); and there were others again, such as the Zaranik, between the coast and hills S. of the Hodeida-San'a road, and the Beni Yam in the interior, who accepted neither Turk nor imam.

The imam Yahya Ibn Mohammed came into power in 1904. After his revolt against the Turks (see 2.270), a patched-up peace was made between them, but in 1911 his forces again beleaguered San'a. The city was eventually relieved by 'Izzet Pasha, who became military governor and succeeded, after some difficulty, in establishing an *entente* with the imam, "for the sake of peace among Moslems." An imperial firman, read at San'a on Sept. 22 1913, proclaimed a "mediatized status" or condominium, by the terms of which the imam secured the religious and social control of all the Zeidites (roughly all the highlands from the Asir border to the Aden frontier) together with part of the central Yemen Tihama, but he received no sanction to impose taxation.

On the outbreak of the World War, the imam refused to enter into relations with Aden, and was strongly opposed to the Idrisi. In 1915, he showed his leaning towards the Turks, by writing a letter to Enver, "praying for the success of the Ottoman armies." He refused to be drawn into any alliance with the sheri of Mecca. Details of the actual happenings in Yemen during hostilities are somewhat obscure, but the imam's chief activity lay in attempts to tamper with the loyalty of the tribes of the Aden protectorate and Hadhramaut, in which he met with partial success. Later, he sought a closer understanding with the King of the Hejaz and, at one time, an alliance seemed possible, but did not materialize. The Turkish garrisons were withdrawn from Yemen at the end of 1918 and a small British-Indian force occupied Hodeida; but there was evidence that Turkish influence did not wholly disappear at the same time. In Aug. 1919, a British mission, sent from Hodeida in the hope of negotiating with the imam at San'a, was captured by Quhra tribesmen at Bajil about 25 m. inland, and was detained until Dec., when it returned to the coast without having accomplished its purpose. In March 1920, the garrison of Hodeida was temporarily increased owing to the uncertainty of the attitude of the imam and some of the Tihama tribes. In Jan. 1921, the forces of the imam, commanded by Mahmud Nedim Bey, the former vali of Yemen, were reported to be attacking the Tihama regions—the conquest of which appeared to be his main objective—and were threatening Hodeida. In Feb., the occupation of Hodeida by Idrisi troops was reported.

**Persian Gulf States.**—The sultanates and sheikhdoms, which extend along the Arabian shores of the Persian Gulf, have all come under British influence, in one form or another. Their rulers are controlled in matters of external relations, and maintain their authority internally by grace of their alliance with Great Britain. None rule effectively over territory more than about a day's march from the coast. The states are as follow:—

**Oman.**—The Sultan of Muscat (see 20.99 and 19.43), claims overlordship of all territory extending from Hadhramaut to the entrance of the Persian Gulf (including Dhofar) and inland, to the Great Desert. In reality his direct rule is restricted to the town of Muscat and a stretch of coast N.W. and S.E. of it. The tribes of the interior are practically independent and have set up an Ibadhi imamate, and if not fighting among themselves are a constant menace to the sultanate. The sheikhs of Rostaq are among the most powerful of these independents. In 1912, under the insistence of the British Government, a warehouse was established at Muscat to control the traffic in arms and ammunition through Oman ports to the interior, which had been greatly abused. A rising of the Ibadhis

against the Sultan, for which this control was made part pretext, took a serious form in 1913-4 and necessitated the bombardment of the ports of Quryat and Barka, and an Indian force occupied Beit el Fej near Muscat. The rebels attacked in strength in Jan. 1915, but met with defeat, which revived the situation. The disaffected tribes continue to dominate the interior, and the authority of the imam, rather than of the Sultan, is recognized by most.

**Trucial Oman,** formerly known as the Pirate Coast, extends for over 300 m. from El Qatar almost to Ras Musandam, and receives its name from the truce established in 1853 between the five recognized ruling sheikhs of the districts of Abu Dhabi, Dibai, Sharja, 'Ajman and Umm el Qaiwan. The position of the respective sheikhs is regulated by an agreement which, in 1892, placed all external relations under British control and made Great Britain responsible for their protection from aggression. The sheikhdoms are very unequal in importance—those of Sharja and Abu Dhabi are the most considerable territorially. The sheikh of Sharja claims to be paramount over all Trucial Oman, but this is repudiated by the other sheikhs and not recognized by Great Britain. An Arab political agent resides at Sharja.

**El Qatar.**—The sheikhdom of El Qatar comprises the peninsula of that name on the Arabian coast E. of Bahrein, of which latter it was formerly regarded as a dependency. Turkish control in El Qatar ceased in 1913, when the emir of Nejd drove the Turks from El Hasa, and the sheikh 'Abdalla ibn Jasim came into power in the same year. He maintained friendly relations with Britain and kept on good terms with the emir of Nejd.

**Bahrein** (see 3.212) consists of an archipelago, of which Bahrein is the most important island. The rule of the sheikh is effective only over that part of Bahrein I. adjacent to the port of Manama and over Muharrag I.: his authority over the remaining islands is little more than nominal. He agreed by treaty, in return for a subsidy, not to alienate any part of his territory except to Britain and to conform to British policy. A political agent, under the resident at Bushire, is stationed at Manama. Throughout the crisis in the pearl industry in 1913, and during the World War, the sheikh showed much goodwill to Britain.

**Kuwait.**—The Sultan of Kuwait (see 15.956), Salim, son of Mubarak, who succeeded his brother Jabir in 1917, claimed jurisdiction over 200 m. of territory from El Hasa almost to the head of the Persian Gulf, and ruled nominally westward to the wells of Hafar, where his district met that of the emir of J. Shammar on the N.E., and that of Nejd on the S.W. The late Sultan Mubarak formally repudiated all relations with the Turks at the outbreak of hostilities and his attitude towards the emir of Nejd was friendly, but towards the emir of Shammar intermittently hostile. In 1920, a serious attack on the independence of Kuwait arising out of the activities of the Akhwan sect of Nejd was threatened. Sultan Salim died early in 1921 and was succeeded by Ahmad ibn Jabir.

On March 1 1921, it was stated in Parliament that matters of policy and administration affecting Arab areas within the British sphere of influence and Aden were transferred to the Colonial Office; but questions regarding the Hejaz remained under the jurisdiction of the Secretary of State for Foreign Affairs. The tendency was for the British Government to rely considerably on officers of the Sudan Civil Service.

**Trade.**—Arabia produces little for export except pearls, dates, coffee, hides and skins; imports consist almost wholly of manufactured fabrics (cotton in particular) and food-stuffs (rice, cereals, flour, sugar and tea). Besides Aden only Muscat, Manama and Kuwait carry on any considerable direct and regular trade with the outer world—the first named with Europe mainly, and the others almost exclusively with India and the East; and Arabian trade in general commodities tends to focus more and more on Aden and Manama. The trade of Jidda—depending largely on the pilgrimages, and seasonal in consequence—though considerable, is of a more local nature and is mainly with Egypt, the near African coast and the Persian Gulf, and India at farthest. The trade of Hodeida, Jeizan, Mocha, Makalla, and the other still smaller ports is almost entirely carried on by sailing craft, though before the World War, Hodeida was also a port of call, at regular intervals, for certain smaller lines of steamers. Commercial enterprise at Arabian ports is mainly in the hands of Indians, especially in Oman, Kuwait, Hadhramaut and even at Aden; second to them come Italians, commercially predominant in many of the Red Sea ports (notably Hodeida), Italian Somaliland and Eritrea offering a convenient base of operations. Prior to the World War, British and Turkish interests were political rather than commercial: neither power had any strong hold on the economic activities of the country, the trade relations between Turkey and the Holy Cities excepted.

The following comparative table gives approximate trade figures (including specie), in thousands of pounds sterling, of the chief ports, in the years just anterior to the World War:—

	Year	Imports	Exports	Total
<b>(a) Western Littoral</b>				
Aden . . . . .	1913-4	4,377	4,149	8,526
Hodeida . . . . .	1912-3	789	490	1,279
Jidda . . . . .	1912-3			1,482
<b>(b) Eastern Littoral</b>				
Muscat . . . . .	1913-4	408	272	680
Manama (Bahrein) . . . . .	"	1,878	1,740	3,618
Kuwait . . . . .	"	371	114	485

**The Western Littoral.**—Trade was much disorganized during the World War and shifted from port to port as the exigence of the time demanded. Normal conditions were by no means resumed even in 1921. General trade figures were not available, but the following table gives (in round numbers) the trade movement between Aden and the chief ports, from 1914-9:—

(April 1 to March 31)	Jidda	Jeizan	Hodeida	Mocha
1913-4	£ 100,000	£ 5,000	£ 619,000	£ 251,000
1914-5	64,000	2,000	387,000	142,000
1915-6	2,000	33,000	1,000	757,000
1916-7	119,000	782,000	nil	34,000
1917-8	126,000	633,000	nil	nil
1918-9	50,000	538,000	5,000	nil

The marked increase at Jeizan was due to war operations in Asir; the almost total extinction of trade at Hodeida in 1916-9 and the temporary revival of Mocha, at the expense of Hodeida, to the blockade of the Yemen coast; and the sudden fall at Jidda in 1915-6 to the temporary blockade of the Hejaz coast just previous to the Arab revolt. There is normally a considerable direct trade between certain Red Sea ports and Egypt (Suez). In 1918, it amounted to about £250,000 of which imports were £225,000, chiefly cotton piece-goods (££157,000), soap, dried beans, sugar and lentils; and exports, chiefly charcoal.

The main item in the trade figures of Jidda is the export of specie amounting, in normal times, to well over £1,000,000 annually. As to trade in general commodities, there is always an enormous excess of imports over exports, due largely to the requirements of pilgrims, the Hejaz producing little. In 1911, imports included rice £233,000 (from India); maize, wheat and barley £181,000; cotton piece-goods £150,000; silk goods and sugar, and, in that year, 287 steam vessels of 616,000 aggregate tonnage entered the port. Exports in the same year did not exceed £50,000 and consisted of skins and hides, wool, henna, gum and mother-of-pearl shells. The number of pilgrims passing through Jidda in 1912 was 83,295.

Midi (Asir), 45 m. S. of Jeizan, became a port of some importance during hostilities. In 1917, the construction of a stone pier for the discharge of cargo was undertaken.

Hodeida was formerly the most important of the southern Red Sea ports, but during the past decade its trade has steadily declined. In 1909, imports amounted to £650,000 and exports to £401,000, the latter consisting mainly of coffee, hides and skins. The Yemen coffee trade, valued at about £300,000 in 1911-2, has passed almost entirely to Aden on account of the greater security of the Aden routes and the better facilities there for husking the berries, and export. In 1921 the port was reported to be almost deserted. The scheme for a new harbour at Khor el Kethib, a good natural inlet 10 m. N., did not materialize.

**The Eastern Littoral.**—The following comparative table summarizes the value of the trade (including specie) of the chief ports, from 1912-20, the figures being in thousands of pounds sterling:—

Year	Muscat			Manama			Kuwait		
	Imp.	Exp.	Total	Imp.	Exp.	Total	Imp.	Exp.	Total
1912-3	464	301	765	2,240	2,295	4,535	438	132	570
1913-4	408	272	680	1,878	1,740	3,618	371	114	485
1914-5	328	275	603	758	462	1,220	292	43	335
1915-6	243	188	431	1,173	369	1,542	292	113	405
1916-7	..	..	..	1,539	780	2,319	472	152	624
1917-8	167	157	324	1,607	817	2,424	1,270	263	1,533
1918-9	290	242	532	1,350	1,318	2,668	904	259	1,253
1919-20	..	..	..	1,414	946	2,360	1,961	276	1,337

Muscat is the main trade outlet of Oman. The decline in trade after 1913-4, shown in the table, was due partly to the opening of Dibal in the Trucial Oman as a free port and partly to the control placed upon the arms traffic in 1912. The import of arms fell from £180,000 to almost nil in the period 1913-5. In 1918-9, 80% of the total trade was with India, 12% with the Arabian coast, and 4.5% with Persian ports, and 42 steam vessels of gross tonnage 57,827 cleared the port; the tonnage carried by sailing vessels was 20,149. The most important article of export is dates (£123,000 in 1918-9), of which the better sorts of dry dates go

to the New York and Boston markets; of secondary importance are pearls, mother-of-pearl and salt fish, mainly to India. Rice from India is the chief import.

Manama holds a somewhat similar position to Aden as a place of transhipment and centre of distribution for eastern and central Arabia. It is the headquarters of the Persian Gulf pearl industry, in which it is said that 5,000 boats are engaged. The exceptional decrease of exports 1914-6 (see above table) was due to the decline in the pearl trade, which fell in value from about £1,800,000 in 1912-3 to £320,000 in 1915-6, causing great economic stress. In 1919-20 the chief imports were rice £406,000, piece-goods £337,000, coffee £93,000, ghl £67,000 and sugar £33,000; exports, pearls £294,000 (£318,000 in 1918 and £702,000 in 1919), rice £261,000, cotton goods £159,000, and coffee. In the same year, 75% of the trade was directly with India and 23% with other ports of the Persian Gulf; and 56 steam vessels of 111,244 aggregate tonnage entered, of which 109,073 was British.

At Kuwait the principal imports (in 1919-20) were cotton piece-goods £384,000, rice £117,000, coffee £21,000, sugar and tea; and exports, rice £58,000 and ghl £14,000. In the same year, 47 steam vessels of 89,800 aggregate tonnage entered. India furnished 82.5% of the total imports, and 70% of the exports were destined for other Arabian ports. Pearl boats valued at £27,000 were built in 1912-3.

**The Interior.**—The principal market centres of the interior of Arabia are: Teima and Kheibar (Hejaz), Mubail and Khamis Mushait (Asir); San'a (Yemen); Makhlaf (Nejran); Lahej (Aden hinterland); Shibam and Haata (Hadhramaut); Sema'il, Rostaq and Nirwa (Oman); Riyadh, Boreida and Hail (central Arabia); and Hofuf (El Hasa). Trade at these centres consists in the collection of the small surplus native agricultural products and in the distribution of manufactured articles and foodstuffs brought in from the coast.

**Communications.**—With the exception of the Hejaz line, Arabia was still without railways at the end of 1920. Two extensions of the Hejaz line were projected: (1) Medina-Mecca; (2) Ma'an-Akaba. The first formed part of the original plan—the distance direct being 280 m. and the estimated cost just under £1,000,000. An alternative route, via Rabugh, was also considered and construction was begun at both Medina and Rabugh, but was abandoned. The Ma'an-Akaba scheme did not go beyond the preliminary survey stage. In 1911, a survey of a railway from Mecca to Jidda was made by the Turks, but construction was postponed. In 1909, French engineers surveyed for a railway which the Turkish Government proposed to build from Hodeida to San'a and Amran. Alternative routes were considered—one direct via Bajil and Hajla, and the other making a detour through Zebid, Ta'iz and Yemim. As a preliminary, a French syndicate constructed 5-6 m. of metre-gauge track, between Hodeida and a proposed new harbour at Khor el Kethib, about 10 m. to the north. The work and all material and plant (including several locomotives) were destroyed in the Italian bombardment of Hodeida, in 1912. In 1918-9 a metre-gauge military line was extended from Sheikh Othman to a few miles beyond Lahej, a total distance of 25 m. from Aden; when not required for military purposes it is available for ordinary transport.

There are no made roads of any considerable length in Arabia, except one of 173 m. from Hodeida to Saa'a; but sections of certain of the caravan tracks were adapted, during the World War, for rough motor service, e.g. the road from Jidda to Mecca and from Akaba to Ma'an. For purposes of trade, the old caravan routes have still to serve. The only route of trans-peninsular character is that from Zebid to Boreida (379 m.), Mecca (479 m.) and Jidda (55 m.); total, 913 m. For the passage of trade as well as pilgrims, no other caravan route in Arabia compares with it in importance.

The lines of telegraph are: Jidda - Mecca; Jidda - Rabugh - Medina; Hodeida - San'a; Hodeida - Mocha - Sheikh Sa'id; Hodeida - Lohaia - Midi; and Mocha - Ta'iz - Yemim - Saa'a.

For travelling or through-trade purposes the *vafiq* or companion system obtains. Each tribe has a recognized *dira* or range, and in passing from the territory of one tribe to that of another a *vafiq* of the last tribe is absolutely necessary for safe conduct. Later-tribes trade is also facilitated by the 'Uzvi, recognized carriers, who are "franked" by all tribes and are thus able to conduct a caravan with more or less security. They are chosen from among the tribesmen of central Arabia and El Hasa, care being taken to exclude members of the more powerful tribes and those who have blood feuds, so as to preserve the neutral character of the organization.

**Industries.**—Camel-rearing is mostly in the hands of the Anaza in the N., the Qahtan and Shammar in the centre, and the 'Ajman and Muteir in the E.; but the herds of the first-named tribe far outnumber those of any other. The centre of the camel trade is in Damascus (where almost all the capital is supplied) and to a less extent in Bagdad. In normal times, the chief tribes are said to possess 720,000 head, but during the World War herds were much depleted. Only the surplus, possibly numbering 45,000 per ann., and those not the best, are sold. A little horse-breeding is carried on by the emir of Nejd and by the Sahran tribes and there is a small export to Mesopotamia and Syria. Considerable numbers of the white, large-boned breeds of asses of El Hasa are sent to Egypt. The fisheries of Arabia, other than pearl, are valuable for the supply of local needs and are capable of development. The salting of fish is an industry at most coast towns, but more particularly those of the Red Sea and Oman; considerable quantities are sent into the interior. During the war operations, some attention was paid incidentally to the study of the Farsan pearl industry and to the possibilities of its development. The rock salt quarries of Salif, opposite Kamaran I., were worked under the control of the Ottoman debt and 105,000 tons of salt were exported to India and the Straits Settlements in 1908. Just prior to the World War an English company was working the quarries; in 1920, operations had ceased for the time being.

**Bibliography.**—Alois Musil, *Nord Arabien, Vorbericht über die Forschungsreise 1908-9* (1909), and *Zur Zeitgeschichte von Arabien* (1918); C. Wyman Bury, *The Land of Us* (1911), *Arabia Infelix* (1915) and *Pan-Islam* (1919); A. J. B. Wavell, *A Modern Pilgrim in Mecca and a Siege in Sanaa* (1912 and 1918); C. Snouck Hurgronje, *The Revolt in Arabia* (1917); *The Holy War "made in Germany"* (1915) and *Nederland en de Islam* (1915); Barclay Rankin, *General Wahhab's Land and the Camelry*; C. Doughty, *Travels in Arabia*, new ed. with introduction by T. E. Lawrence (1920); I. D. 1128, *A Handbook of Arabia*, vol. I, General, compiled by the Geographical Section of the Naval Intelligence Division, Naval Staff, Admiralty (1915).

Among valuable contributions to the study of Arabia are the following papers published in the *Geographical Journal*—Captain S. Butler, "Baghdad to Damascus via Jauf, Northern Arabia," vol. xxxiii. (May 1909); Douglas Caruthers, "A Journey in North-Western Arabia," vol. xxxv. (March 1910); Lt.-Col. S. B. Miles, "On the Border of the Great Desert: a Journey in Oman," vol. xxxvi. (Aug. 1910); Captain G. Leachman, "A Journey in North-Eastern Arabia," vol. xxxvii. (March 1911), and "A Journey through Central Arabia," vol. xliii. (May 1914); Gertrude Lowthian Bell, "A Journey in Northern Arabia," vol. xliii. (July 1914); H. St. J. B. Philby, "Southern Nejd" (with map, scale 1:1,250,000), vol. lv. (March 1920) and "Across Arabia: From the Persian Gulf to the Red Sea" (with map, scale 1:2,000,000), vol. lvi. (Dec. 1920); D. G. Hogarth, "War and Discovery in Arabia," vol. lv. (June 1920); and "An Account of A. Benetton's Railway Surveys in the Yemen, and Maps," vol. xliii. (Jan. 1914).

**Maps.**—Map on the scale of 1:1,000,000 compiled by the Geographical Section, General Staff, No. 2,555: Sheets 137 (Esh Sham, Damascus 1918); 138 (Bagdad 1918); H36 (Cairo 1918); H37 (El Djauf 1918); H38 (Basra, 1918); G39 (Holuf, 1920); G37 (Medina 1921); and Sheet G38 (Riyadh) in course of preparation (1921). Map on the scale of 1:1,000,000, compiled by the Survey of India: Sheets of Kufra, Sarā, and Muzakka (1917). Map of Arabia and the Persian Gulf, Survey of India; scale 1 in. = 48 m.; two sheets; and scale 1 in. = 32 m., four sheets. Yamen: Chemin de Fer Hodeidah Sanaa et Embranchement, échelle 1-250,000, A. Benetton, Paris 1913. (H. W. M.)

**ARABI PASHA** (c.1839-1911), Egyptian soldier and revolutionary leader (see 2.283), died at Cairo Sept. 28 1911.

**ARBUR, EDWARD** (1836-1912), English man of letters (see 2.323), was killed in a taxicab accident in London Nov. 23 1912.

**ARBITRATION AND CONCILIATION [LABOUR]** (see 2.331).—Subsequently to 1910, many countries found it necessary to revise their position in regard to arbitration and conciliation in industrial disputes. The growing organization of workers in trade unions which was a marked feature of the last generation rapidly increased as a result of the demand for labour occasioned by the World War; and the feelings aroused by, and the conditions resulting from, the war led to increasing demands on behalf of workers in all countries, which the strong economic position of the workers enabled them to enforce. The war itself in certain instances necessitated exceptional measures in

order that the output of munitions of war might not be hindered by strikes and lockouts. Further, the development of industry has been towards more and more specialization and a still closer inter-relation of industry, so that the effects of strikes and lockouts extend far beyond those immediately concerned and may have most disastrous effects on the public. For this reason the state is forced, in the interests of the community, to take cognisance of trade disputes.

#### UNITED KINGDOM

The position in the United Kingdom, at the outbreak of the World War, was that questions affecting rates of wages and conditions of employment were settled normally by discussion between the parties concerned. During the course of half a century, voluntary conciliation boards, standing joint committees or corresponding procedure had been established in all well-organized industries and this procedure was instrumental in settling large numbers of disputes. In certain important industries, e.g. agriculture and transport, the workpeople and employers were not sufficiently organized in associations to render such permanent machinery practicable. The statutory powers of intervention in labour disputes held by the Government were derived solely from the Conciliation Act, 1896, an Act framed upon a purely voluntary basis. A connecting link between the activities of the conciliation boards and those of the Government in the settlement of labour disputes was the provision in the regulations governing the procedure of a number of boards for the reference of differences to arbitration under the auspices of the appropriate Government department (since 1916 the Ministry of Labour), and further by the policy of the department in not intervening in a dispute, until the parties had exhausted their efforts to bring about an amicable settlement.

During the period immediately following the passing of the Conciliation Act, comparatively little use was made of the procedure of the Act, but the three years immediately preceding the war were years of very marked industrial unrest in the United Kingdom and there was a corresponding increase in the use made of the provisions of the Act. Serious consideration was given by the Government to the question of strengthening their powers in relation to labour disputes, but up to the outbreak of war no steps had been taken to formulate legislative proposals. In this connexion, reference may be made to the report of Sir George (afterwards Lord) Asquith of Dec. 1912, on the Industrial Disputes Investigation Act of Canada (Cd. 6603), and the report of the Industrial Council on Industrial Agreements (Cd. 6952).

**Committee on Production.**—The needs of the war and the abnormal conditions arising therefrom made both necessary and possible much stronger Government action in regard to stoppages of work. The outburst of patriotic feeling which followed the declaration of war resulted in employers and workpeople voluntarily bringing to a close the existing and pending disputes, but the economic conditions resulting from the war soon produced a fresh series of labour difficulties. In Feb. 1915, the Committee on Production, consisting of Sir George Asquith, Sir Francis Hopwood (Lord Southborough) and Sir George Gibb, representing the Board of Trade, the Admiralty and the War Office respectively, was established by the Government to enquire into and report as to the best steps to be taken "to ensure that the productive power of employees in engineering and ship-building establishments working for Government purposes should be made fully available, so as to meet the needs of the nation in the present emergency." With the establishment of the Ministry of Munitions, the functions of the Committee in relation to production were absorbed by that Ministry; but in the meantime the Committee had developed, as a result of the acceptance by the Government of one of its earlier recommendations on the subject of stoppages of work, into an arbitration tribunal. It had no statutory position until the passing of the first Munitions of War Act in July 1915, but it quickly developed into the principal arbitration tribunal for the settlement of labour disputes and attained remarkable success. In 1917 the



Committee was reorganized, representatives of employers and workpeople being added, to sit with the independent chairman. The Committee ceased to exist at the termination of the war when its place was taken by the Interim Court of Arbitration established under the Wages (Temporary Regulation) Act. During its period of existence, it issued over 3,750 awards covering most of the important industries in the country and dealing with all kinds of questions of wages and working conditions. In particular, reference may be made to the agreements negotiated, first in the engineering and allied trades and later in a large number of other trades, whereby the associations of employers and workpeople agreed to suspend existing agreements for the determination of general wages questions and to refer to the Committee on Production every four months the determination of the question what general alteration of wages, if any, was warranted by the abnormal conditions then existing and due to the war, with further power to determine special district cases.

The next important development after the institution of the Committee on Production in Feb. 1915, was the "Treasury Agreement" on the subject of the acceleration of output on Government work, negotiated between the Government and the principal trade-unions in March 1915. The Government's main proposals embodied in the Agreement were on the one hand to limit profits and on the other to prevent stoppages of work owing to trade disputes, and to secure the suspension during the war of trade-union restrictions on output. Although this agreement marked a definite stage of advance, real progress was not made until the Government embodied their proposals in the Munitions of War Act, 1915. This act was subsequently strengthened by two further Munitions of War Acts in 1916 and 1917.

**Munitions Acts.**—Under the Munitions of War Acts, a stoppage of work arising out of a difference on or in connection with munitions work (which expression was given a very wide interpretation as the result of decisions of the High Court) became illegal unless the difference had been reported to the Board of Trade (subsequently to the Ministry of Labour) and had not, within 21 days from the date of the report, been referred for settlement. The compulsory arbitration thus introduced by the Acts was necessarily accompanied by the statutory enforcement of awards issued thereunder. For this purpose the existing forms of arbitration tribunal were utilized, viz. (1) Committee on Production; (2) single arbitrator, selected by agreement between the parties or, failing agreement, appointed by the Board of Trade (subsequently by the Ministry of Labour); and (3) *ad hoc* boards of arbitration, consisting of an independent chairman, an employers' representative and a labour representative. This last form of tribunal had been introduced in 1908 for appointments under the Conciliation Act in order to meet any objection on the part of Labour that, however fair a single arbitrator might be, he could better determine the matters at issue if there were associated with him persons directly acquainted with the point of view of employers and workpeople respectively. The Act of 1915 left it to the option of the Board of Trade to refer any difference reported under the Act to arbitration; the Amending Act of 1916 required the Board of Trade to refer such a difference if satisfied that it was *bona fide*. Although the definition of "munitions work" under the Acts was very wide, it did not include some very important industries such as mining, transport and agriculture, but a further provision of the 1915 Act enabled the parts of the Act relative to the prohibition of strikes and lockouts and compulsory arbitration to be applied to work of any description (in addition to munitions work) by His Majesty by proclamation, and this course was adopted in certain instances (notably, South Wales coal miners, Lancashire card and blowing room operatives, and dockers at London, Liverpool and Glasgow). It may further be noted that the Munitions of War Acts contained no prohibition of incitement to strike. Consideration was given to this aspect of the problem and in Nov. 1915 the Defence of the Realm Regulation No. 42 was amended by the addition of the words in italics as indicated below:—

If any person attempts to cause mutiny, sedition or disaffection among any of His Majesty's forces or among the civilian population,

or to impede or restrict the production, repair or transport of war material or any other work necessary for the prosecution of the war, he shall be guilty of an offence against these Regulations.

The Acts also authorized the Minister of Munitions *inter alia* to issue orders determining the rates of wages of particular classes of workpeople and a considerable number of orders were issued with regard to the rates of remuneration of women and girls. Other orders which had widespread effects were the orders made in Oct. 1917, giving a bonus of 12½% on earnings to skilled time workers in engineering establishments and in shipyards, with a view to attempting to meet difficulties which had arisen owing to the altered relation between the earnings of skilled time workers and the unskilled and semi-skilled men on piece work. Three special arbitration tribunals were established for the determination of matters arising out of the various orders made under the 1916 and 1917 Acts.

Under the procedure of the Munitions of War Acts, arbitration became the normal method for the settlement of labour disputes. From the point of view of the workpeople, it was more expeditious to claim arbitration under the Acts than to endeavour to secure a settlement by conciliation machinery or other negotiations and, moreover, an award under the Acts was statutorily enforceable. On the employers' side also, arbitration was often found to be the most satisfactory procedure; when so much work was being done for Government purposes, the employers' financial interest in the result of negotiations was diminished. A further development was that in many industries (e.g. the railways and coal mines) the conciliation boards fell into abeyance. During the war wages claims were necessarily determined largely in reference to the cost of living and consequently unions made claims for national advances in place of district claims. The net result, therefore, was a very large increase in the number of arbitrations under Government auspices and a falling off in conciliation settlements. During the four years 1915-8, nearly 8,000 awards were issued by arbitration tribunals under the Munitions of War Acts and, to a small extent, under the Conciliation Act, 1906. The Munitions of War Acts also introduced certain other features which have a considerable bearing on the settlement of labour differences, such as the power given to the Minister of Munitions under the Munitions of War Act, 1917, to extend an award, applying to the greater part of an industry, to other firms not party to the award but engaged on the same class of work.

It may be recorded that the New Ministries and Secretaries Act, 1916, transferred the powers of the Board of Trade under the Conciliation Act and the Munitions of War Acts to the newly created Ministry of Labour.

**Wages Regulation Act.**—Immediately after the Armistice, the Government, at a national conference of employers and workpeople on Nov. 13 1918, intimated that their post-war policy in relation to labour disputes was to leave employers and workpeople to adjust so far as possible their own differences. Certain proposals were placed before the conference for the period of transition while industry was changing over from war to peace conditions. These proposals, which were accepted by the employers and by the trade unions, were embodied in the Wages (Temporary Regulation) Act. The broad principle of that Act was to maintain as minimum rates, for a period of six months, the standard district rates existing at the date of the Armistice. Wages having been regulated during the war mainly in relation to the cost of living, they had at the date of the Armistice reached a level far above the pre-war rate. It was not anticipated that the cost of living would fall considerably immediately after the Armistice, while there was a fear that rapid demobilization might so disturb the labour market as to result in attempts at wage reduction of a kind which would lead to great industrial unrest. The Act repealed the prohibition of strikes and lockouts contained in the Munitions of War Acts, and limited compulsory arbitration to the wage standards dealt with in the new Act; it continued, in the Interim Court of Arbitration, the principle of a central arbitration tribunal which had been so successful in the form of the Committee on Production.



The termination of the war was followed by an outburst of unrest, and the position became so serious that in Feb. 1919, the Government summoned a further national conference of employers and workpeople to consider the position. A committee appointed by the conference subsequently made a number of proposals on questions relating to hours, wages, and general conditions of employment, unemployment and its prevention, and the best methods of promoting coöperation between capital and labour. As regards wages, one of the recommendations was the continuance of the Wages (Temporary Regulation) Act, 1918 for a further period of six months, and this recommendation was adopted by the Government in the Wages (Temporary Regulation) Extension Act, 1919.

In connexion with this period of unrest, special reference may be made to the coal-mining industry where the position became so acute in connexion with demands of the Miners' Federation, including a demand for the nationalization of the industry, that in Feb. 1919 the Government set up a commission (under the Coal Industry Commission Act) to inquire into the position of, and conditions prevailing in, the industry. (For the reports of this commission see Cmd. 359, 360 and 361 of 1919.)

During the war a number of committees and commissions had been appointed by the Government to inquire into problems connected with labour disputes. Thus, there were (1) an inquiry by Lord Balfour of Burleigh and Sir Lynden Macassey, K.C., into "the cause and the circumstances of the apprehended differences affecting munition workers in the Clyde district," Dec. 1915; (2) a commission appointed in June 1917 to "inquire into and report upon industrial unrest and to make recommendations to the Government"—reports summarized by Mr. G. N. Barnes, M.P. (Cd. 8696); (3) a committee under the chairmanship of Mr. Justice Atkin, appointed in 1918 as a result of a strike of omnibus workers to investigate and report as to the relations which should be maintained between the wages of men and women, having regard to the interests of both, as well as the value of their work (Cd. 835); (4) a committee appointed in 1918 under the chairmanship of Mr. Justice McCardie to inquire into matters connected with a strike of munition workers at Coventry and elsewhere in connexion with the Government embargoes on the transfer of employment of skilled men; and (5) a committee appointed in Oct. 1916, under the chairmanship of Mr. J. H. Whitley, to make suggestions for securing a permanent improvement in the relations between employers and employed (Cd. 9153, etc.).

*Whitley Committee.*—The recommendations of the last-named committee were of far-reaching importance and in fact formed the basis of the Government's post-war policy in regard to industrial relations and strikes and lockouts. The committee recommended the setting up of joint industrial councils (now sometimes called "Whitley Councils") in trades where employers and workpeople were sufficiently organized, the extension of trade boards for poorly organized trades, and the temporary establishment of other bodies for "intermediate" trades. The committee's recommendations with regard to the establishment of joint industrial councils were prefaced by a declaration to the effect that in the interests of the community it is vital that after the war coöperation of all classes, established during the war, should continue, more especially with regard to the relations between employers and employed, and that, for securing improvement in the latter, it is essential that any proposals put forward should offer to workpeople the means of attaining improved conditions of employment and a higher standard of comfort generally, and involve the enlistment of their active and continuous coöperation in the promotion of industry. The committee then recommended that H.M. Government should propose without delay to the various associations of employers and employed the establishment for each industry of an organization, representative of employers and workpeople, to have as its object the regular consideration of matters affecting the progress and well-being of the trade from the point of view of all those engaged in it so far as this is consistent with the general interest of the community. The committee recommended that the

national councils should be supplemented by the creation of district councils and works committees to deal with district and local matters respectively and they outlined the questions with which the national councils, district councils, or works committees might deal. The Government intimated their acceptance of the recommendations of the Whitley Committee and at this date (Dec. 1920) 63 joint industrial councils have been established in various industries in the country. The Government have applied the machinery in their own industrial establishments and also in the civil service. The committee also issued a report on conciliation and arbitration and their recommendations thereon were as follows:—

(1) Whilst we are opposed to any system of compulsory arbitration, we are in favour of the extension of voluntary machinery for the adjustment of disputes. Where the parties are unable to adjust their differences, we think that there should be means by which an independent inquiry may be made into the facts and circumstances of the dispute and an authoritative announcement made thereon though we do not think that there should be any compulsory power of delaying strikes and lockouts.

(2) We further recommend that there should be established a standing arbitration council for cases where the parties wish to refer any dispute to arbitration; though it is desirable that single arbitrators should be available where the parties so desire.

The constitution and functions of the joint industrial councils are in many respects similar to those of conciliation boards, but whereas the latter have dealt mainly with questions affecting rates of wages and conditions of labour or demarcation of work between various classes of operatives, the industrial councils are designed to have a wider scope and can take into consideration matters of every kind which appertain to the welfare and smooth working of the industry. The encouragement of joint industrial councils formed a definite part of the broad policy of the Government to encourage industries so far as possible to settle their own disputes. In certain large and important industries (coal-mining, railways, agriculture) where the Government have not yet found it possible to relinquish their special war relations, while joint industrial councils have not been established, the Government have taken steps to set up special conciliation machinery. For example, in coal-mining special machinery is provided for by the Mining Industry Act of 1920; for railways, the Government have established special conciliation machinery, including a national wages board; and in agriculture, wages boards have been established under the Corn Production Act, 1917, and Agriculture Act, 1920. The voluntary conciliation machinery which was the fundamental factor in this country before the war, but which was in suspense during the war, is therefore now being re-established on a substantially wider basis and the result of the establishment of the industrial councils has undoubtedly been greatly to increase the opportunities for the conciliatory discussion and adjustment of labour disputes.

The recommendation of the Whitley Committee with regard to trade boards was also adopted by the Government and, following the passing of the Trade Boards Act of 1918, the Government embarked on a policy of the extension of trade boards. These boards differ from Whitley Councils in that they consist partly of representatives of the employers and workpeople in the trade and partly of persons appointed by the Government; their determinations are statutorily enforceable as minimum rates and extend to the whole of the trade and, moreover, the boards are established in industries where the organization of employers and workpeople is weak. While they would not normally be included in the definition of conciliation machinery, it is advisable to note them in connexion therewith as, by establishing minimum rates of wages in low-paid industries, they tend to remove one of the root causes of labour unrest. Moreover, the meetings of employers and employed for trade board business afford opportunities for the mutual discussion of other matters and thus tend to improve the relations between the parties.

*Industrial Courts Act.*—The recommendations of the Whitley Committee on the subject of conciliation and arbitration formed the basis of the Industrial Courts Act, which was passed in Nov. 1919. This act sets up alternative forms of tribunals to which recourse can be had, if both parties to a dispute agree. Of these,

the principal tribunal is a permanent court of arbitration (called the Industrial Court) consisting of persons appointed by the Minister of Labour, of whom some are independent persons, some are persons representing employers, and some are persons representing workmen; there are also women members. There is a permanent president of the court and in addition there are chairmen of divisions of the court. The other forms of tribunal provided for by the Act are (a) single arbitrators and (b) boards of arbitration consisting of one or more persons nominated by the employers, an equal number nominated by the workpeople, with an independent chairman nominated by the minister. For the purpose of these boards of arbitration, panels of persons (including women) suitable to act in the respective capacities are constituted by the minister. The Industrial Courts Act further empowers the Minister of Labour in the case of disputes, either apprehended or existing, to appoint a court of inquiry, one of the objects of which is to put before the public an impartial account of the merits of the dispute. The Act continued until Sept. 30, 1920 the principle of the Wages (Temporary Regulation) Acts, 1918 and 1919, that broadly speaking the wages ruling at the time of the Armistice should remain in force as standard minimum rates. (The Conciliation Act, 1896, continues in existence, but in practice its provisions are covered by the Industrial Courts Act.) The provisions in relation to the appointment of courts of inquiry, for the purpose of making a public inquiry and public report upon the facts and circumstances of a dispute likely to affect seriously the public interest, is based upon the Canadian Industrial Disputes Investigation Act, but while the British Act (like the Canadian Act) provides for the grant to the courts of inquiry of certain compulsory powers to secure the attendance of witnesses, the production of documents, etc., it differs from the Canadian Act inasmuch as it makes no attempt to prohibit a strike or lockout pending the inquiry. The British Act relies entirely upon the value of publicity and the effect of public opinion. In this connexion it may be mentioned that the experience of the working of the Canadian Act has shown that it has failed in practice to prohibit strikes or lockouts and that its success has lain in the power to secure an impartial inquiry and a public pronouncement upon the facts and circumstances of the disputes concerned.

During the first year of the Industrial Courts Act over 500 cases were referred to the arbitration of the industrial court, a number of the cases being of considerable importance as concerning the wage rates of the whole industry. During the same period courts of inquiry were appointed in three instances with satisfactory results.

**Compulsory Arbitration.**—Certain aspects of conciliation and arbitration procedure in the United Kingdom have aroused special consideration during recent years. From time to time, proposals have been put forward in favour of declaring strikes and lockouts illegal and instituting compulsory arbitration; at trades union congresses, however, resolutions in favour of compulsory arbitration have been defeated by large majorities. Laws on this basis have existed for some time in Australasia and, under the pressure of war conditions, legal prohibition of strikes and lockouts and compulsory arbitration were introduced in the United Kingdom. Success was, however, only partial, and the experience of this period affords no reliable guide as to what might be expected to occur under more normal conditions. A large number of strikes and lockouts, some of considerable magnitude, did in fact occur, and probably the principal influence in restricting the number of stoppages during the war period was the patriotic spirit and the determination on the part of all classes to bring the war to a successful conclusion. The Whitley Committee on the relations between employers and employed came to the following conclusion on this subject:—

We are opposed to any system of compulsory arbitration; there is no reason to believe that such a system is generally desired by employers and employed and, in the absence of such general acceptance, it is obvious that its imposition would lead to unrest. The experience of compulsory arbitration during the war has shown that it is not a successful method of avoiding disputes, and in normal times it would undoubtedly prove even less successful. Dis-

putes can only be avoided by agreement between employers and workers and by giving to the latter the greater measure of interest in the industry, advocated in our former reports; but agreement may naturally include the decision of both parties to refer any specified matter or matters to arbitration, whether this decision is reached before or after a dispute arises.

For the same reason we do not recommend any scheme relating to conciliation which compulsorily prevents strikes or lockouts pending inquiry.

**Various Proposals.**—Another matter to which considerable attention has been given is the question of the extension to the whole of a trade or industry of the terms of an award or agreement applying to a particular body of employers. In 1913 the Industrial Council under the chairmanship of Sir George Askwith reported that, subject to the agreement fulfilling certain requirements and to an inquiry by the appropriate Government department, an agreement entered into between an association or associations of employers and workpeople covering a considerable part of the trade or district should be made applicable to the whole of the trade or district concerned. The question was considered at trades union congresses in 1912 and 1913 and also by the Labour party in 1913 and was rejected at all these meetings. A recommendation appended to a number of the war agreements for four monthly arbitrations was put into effect by the Munitions of War Act, 1917, which contained a section empowering the Minister of Munitions to extend awards or agreements, if satisfied that they were binding upon the employers employing the majority of the persons engaged on or in connexion with munitions work in any trade or branch of a trade either generally or in a particular district, and a number of orders were issued for this purpose. Under the Wages (Temporary Regulation) Acts, the Minister of Labour had a certain limited power of extending awards and agreements. The report of the provisional joint committee of the industrial conference of 1919 also contained a recommendation for the extension of agreements providing for minimum rates of wages. Proposals with a view to extension were put forward at the time of the introduction of the Industrial Courts Bill, but the conditions which, in the view of the Government, must necessarily be attached to such a proposal, were not acceptable to the workpeople's organizations and accordingly the Industrial Courts Act did not contain any provisions for that purpose. This subject is one upon which there is clearly considerable divergence of opinion.

Another movement to which reference may be made is the proposals which have been put forward from time to time for the setting up of a national joint organization of employers and workpeople to cover all trades. In 1911 an industrial council was established under the chairmanship of Sir George Askwith, consisting of 13 leading representatives of employers and 13 leading representatives of labour from all branches of industry, but save for a report on the extension of industrial agreements, the council did comparatively little work and in due course it lapsed. In connexion with the industrial conference in Feb. 1919, proposals were made for the establishment of a national joint industrial council representative of employers and workpeople, but so far it has not been found practicable to establish such a body. A somewhat similar movement is the proposal, also so far unsuccessful, to establish a national association of joint industrial councils. The lack of success which these proposals have so far achieved would appear to suggest that the highly organized industries prefer to be able to deal independently with their own difficulties and are averse to intervention by outside bodies.

The increased organization of employers and workpeople in the United Kingdom which resulted from war conditions has had substantial effects on the machinery for conciliation and arbitration. Labour realized from its strong economic position the power of combination, but attempts at general strikes after the war have also indicated the limitations of the strike weapon, and in addition have impressed on the trade-union movement the need for co-ordination. This is having effect in the proposals now under discussion for the establishment of a General Staff for labour. On the other hand, recent strikes have produced in certain quarters demands for the institution of some measure such as a ballot—to be taken in a manner prescribed by statute—prior to a declaration of a strike, but the trade unions are not likely willingly to forego the "lightning

strike." With organization comes the establishment of machinery for the mutual discussion of differences, and discussion often leads to an amicable settlement; on the other hand, with employers and workpeople strongly organized in their respective associations, the claims advanced on behalf of labour develop beyond claims about wages and working conditions, and extend to questions of principle such as labour's right to share in the management and control of industry. Further, when a strike or lockout does occur, it often has far-reaching effects and impresses itself on the mind of the public, who tend to overlook the numerous differences which might have led to stoppages of work, but were adjusted by discussion. It is largely on the ground of the effect on the public that the State is held to be justified in introducing restrictive legislation for dealing with strikes and lockouts, particularly in the group of industries known as "public utility" services, and, failing settlement, of taking exceptional powers such as those conferred on the Government under the Emergency Powers Act, 1920. A further development of organization has been that the larger trade unions appear in some instances to have become over-centralized, and in this connexion the growth of works committees may well be worth watching. Generally it may be said that in recent years there has been in the United Kingdom a very marked increase in the regular meetings of employers and employed for the purpose of discussion of matters which may be at issue between them; and while it cannot yet be said that there is freedom from suspicion and distrust there is clear evidence of the growth of a desire for full and frank discussion of all matters affecting the relations between employers and employed.

The conciliation and arbitration machinery of the British Government is frankly based on the acceptance of organization by employers and workmen into their respective associations; the joint industrial council scheme is based on organization, and the Industrial Courts Act definitely provides that a difference shall not be referred by the Ministry of Labour to arbitration until there has been failure to adjust the difference by the conciliation machinery existing in the industry.

#### BRITISH COLONIAL LEGISLATION

In connexion with British colonial legislation on the subject of conciliation and arbitration, it may be recorded that in *Canada* the Industrial Disputes Investigation Act of 1907 continues to represent the legislative position of the Government.

In *Australasia* a considerable number of amendments have been made. In New Zealand the Industrial Conciliation and Arbitration Act has been amended to enable awards and agreements to be amended to meet alterations in conditions of employment and the cost of living. Further, the existing machinery was strengthened by the Labour Disputes Investigation Act, 1913, which provides machinery for the investigation of disputes not coming within the scope of the Industrial Conciliation and Arbitration Act. The 1913 Act provides for conference of the parties with a view to securing an amicable settlement, or, in the alternative, investigation by labour disputes committees. Before a strike may lawfully take place, a ballot of the workers is taken by the registrar of industrial unions and the result of the ballot publicly notified. After the lapse of seven days from the publication of such result, the workers are free to strike, whatever the result of the ballot may have been. Similar provisions are made to apply in the case of lockouts. Most of the states of Australia have passed new laws on this subject. In Victoria, under the Factory and Shops Acts of 1915 and 1919, and in Tasmania under the Wages Boards Acts of 1910, 1911, 1913 and 1917, there is a wages board system; in Victoria there is no prohibition of strikes and lockouts, but in Tasmania penalties are provided for stoppages of work on account of any matter in respect of which a board has made a determination. In Western Australia, the Industrial Arbitration Act of 1912 provides for an Industrial Arbitration Court and prohibits strikes and lockouts, while in New South Wales under the Industrial Arbitration Acts of 1912, 1916, 1918 and 1919, in Queensland under the Industrial Arbitration Act of 1916, and in South Australia under the Factory Acts of 1907, 1908, 1910 and 1915 and the Industrial Arbitration Acts of 1912, 1915 and 1916, there are both a wages board and an industrial court system. In accordance with the provisions of the Acts in New South Wales and Queensland, the industrial courts in those states have been exercising the functions of wages boards, and the work of the existing boards has been greatly curtailed. Under the industrial court system, an industry does not technically come under review until a dispute has actually arisen, but most of the Acts have given the president of the court power to summon a compulsory conference. The Commonwealth of Australia has also recently amended its procedure by means of the Industrial Peace Act, 1920, which sets up certain advisory councils (Commonwealth and District) for considering matters affecting the prevention and settlement of trade disputes and further authorizes the governor-general to set up special tribunals (Commonwealth and District) empowered to issue enforceable awards on any industrial disputes (1) referred by the parties to the dispute, or (2) as to which the tribunal or other appropriate authority has convened a compulsory conference and a complete agreement has not been reached.

#### OTHER COUNTRIES

The movement in the United States is dealt with in a subsequent section of this article. A considerable number of other countries have amended their laws on the subject of the settlement of strikes and lockouts.

In *Norway* a law dated Aug. 1915 introduced for the first time in that country machinery for the settlement of labour disputes by the State. One noteworthy feature of the new measure was the application of the principle of compulsory investigation and delay before a stoppage of work takes place, in which respect it resembles the Canadian Industrial Disputes Investigation Act of 1907. Another noteworthy feature is the compulsory registration of trade unions and employers' associations and the recognition and regulation of collective agreements. Two methods of procedure are established for the prevention and settlement of labour disputes. Questions arising out of existing collective agreements must be brought before a specially constituted labour court, while those originating from other matters affecting labour are to be submitted to conciliation boards to be set up throughout the country. This was followed in 1916 by a compulsory arbitration law. It should also be noted that the Provisional Works Councils Act of July 1920 requires the establishment of a works council in every establishment employing regularly throughout the year not less than 50 workers, on a demand of one-fourth of the workpeople. The functions of the councils are advisory only; they may consider and express an opinion on matters concerning the establishment so far as they relate to working conditions, rates of remuneration, workshop regulations, welfare institutions, etc. No penalty is laid down for failure to comply with the terms of this law.

In *Sweden* the law of 1906 providing for the appointment of conciliators was subjected to inquiry from 1916 onwards with a view to revision and, as a result, it was superseded by three new measures all dated April 1920. The first is a law amending and extending the original law in respect of the appointment of local official conciliators; the second establishes a permanent Arbitration Court (consisting of three impartial persons nominated by the Crown and representatives of organized employers and workpeople) to deal with disputes arising out of collective agreements, without recourse to strikes or lockouts or to legal process in the ordinary courts; whilst the third relates to the appointment, on request, of special arbitrators for individual disputes arising out of collective agreements and involving matters of minor importance. Recourse to the Arbitration Court is voluntary.

In *Rumania* in Aug. 1920 a bill was passed for settling industrial disputes. Strikes and lockouts without recourse to conciliation are prohibited in establishments employing ten or more persons. When a dispute arises, a conference is required to be held in the presence of an official of the Ministry of Labour and if an agreement is reached the decision becomes obligatory on all the parties. Arbitration may be resorted to where conciliation fails and is compulsory in the case of Government establishments and what might be broadly described as "public utility" services. Provision is made for widening the scope of the proceedings and altering the constitution of the Arbitration Court so that the decision may be made applicable to all establishments similar to those involved in the initial dispute. The decision arrived at is obligatory on all parties.

In *Switzerland* the Factory Act of 1877, which was amended in certain respects in 1905, was repealed and superseded by a new labour law of June 1914, which included within its scope measures for averting and settling industrial disputes. The Act provided, with a view to the amicable settlement of disputes which are calculated to lead to a strike or lockout, for the appointment of permanent cantonal conciliation committees which might intervene either on their own initiative or at the request of the authorities or of the parties directly concerned. Persons summoned before these tribunals are obliged, under penalty, to appear. A certain number of employers and workpeople in any industry may mutually agree to constitute a conciliation committee so far as those employers and workpeople are concerned.

In *Germany* a decree of the new Government of Dec. 1918 continued, for the purpose of the settlement of labour disputes and pending arrangements of further statutory regulations, the system of district conciliation committees which had been established during the war. The constitution, functions and powers of these conciliation committees are similar to those of the industrial courts which have been in existence in Germany for many years, in so far as these latter deal with the settlement of ordinary labour disputes. An Act of Jan. 1920 requires the setting up of works councils, one of whose functions it is to appeal to the conciliation committee or to an arbitration board to be agreed upon, failing a settlement of disputes at the works. It may be noted that at these works councils are vested with very wide powers such as the right to demand information of all business transactions. The works councils are to be united in district councils whose work will be coordinated in a federal works council; these can meet representatives of employers in district economic councils and in a federal economic council. A provisional federal economic council has already been established although the subordinate organizations are not yet in existence. A

bill has been under consideration during 1920 in which it is proposed to make recourse to conciliation compulsory and to make the decisions of the conciliation boards obligatory (a) in public services where they are established by law, and (b) in industries where they exist by reason of a collective agreement; in other cases a strike or lockout may be called in spite of a decision, if a ballot is taken and a two-third majority is secured in favour of a stoppage. Meanwhile, as the outcome of a strike of electrical workers in Berlin, a presidential order was issued in Nov. 1920, relative to strikes and lockouts in establishments supplying the community with gas, water or electricity. Under the order lockouts and strikes in such establishments are permissible only after the lapse of three days from the publication of an award by the competent conciliation committee; persons who incite to a strike or lockout, prohibited under the order, or who, for the purpose of bringing about such a strike, perform acts in regard to a workshop, machinery or equipment by which the regular carrying on of the undertaking is hampered or rendered impossible, are liable to imprisonment or a fine—liability to penalty is also incurred by anyone who proclaims a lockout in the circumstances defined; if establishments of the nature indicated are brought entirely or partially to a standstill as a result of a lockout or strike, the Minister of the Interior is empowered to take emergency measures for the maintenance of supplies, including the satisfaction of justifiable demands made by the workers. The cost of putting such measures into operation falls upon the owner of the establishment.

**BIBLIOGRAPHY.**—The principal sources of information are the series of reports and periodica issued formerly by the Board of Trade and now by the Ministry of Labour, viz.: *Proceedings under the Conciliation Act*, including latterly work done under the *Munitions of War Acts, Wages (Temporary Regulation) Acts* and the *Industrial Courts Act; Strikes and Lockouts*—these reports contain some particulars of the work of voluntary conciliation and arbitration boards; second *Report on Rules of Voluntary Conciliation and Arbitration Boards and Joint Committees*; fourth *Abstract of Foreign Labor Statistics*. The monthly *Laborer Gazette* continues to give valuable information both as to the position in the United Kingdom and abroad; and the information as to the dominions and foreign countries is now supplemented by a new quarterly periodical entitled *Labour Overseas*. Special publications of value are the series of reports of the *Committee on the Relations between Employers and Employed*—better known as the "Whitley Committee" (Cd. 9153, etc.); Memoranda issued by the Board of Trade on *Laws in the British Dominions and Foreign Countries affecting strikes and lockouts with special reference to Public Utility Services* (Cd. 6081 of 1912); *Report of Sir George Ashwith on the Industrial Disputes Investigation Act of Canada* in Dec. 1912 (Cd. 6603 of 1912); *Report of the Industrial Council of 1913 on Enquiry into Industrial Agreements* (Cd. 6952); and *Reports of the Coal Industry Commission* (Cmd. 359, 360 and 361 of 1919); see also the reports of the various countries, e.g. *New Zealand Official Year Book; Official Year Book of the Commonwealth of Australia; Reports of the United States Department of Labor*, etc. See also Articles on **INDUSTRIAL COUNCILS, LABOUR REGULATION, STRIKES AND LOCKOUTS, TRADE BOARDS.** (H. J. W.)

#### UNITED STATES

In the United States the movement for state legislation for voluntary arbitration and conciliation progressed steadily, until in 1920 a majority of states had legislation providing for the settlement of industrial disputes. Many of these states have permanent boards of conciliation and arbitration with two to six members, though three is the usual number. In some states the labour commissioner acts as mediator, while in others a chief mediator is appointed by industrial commissions together with temporary boards of arbitration. Twenty states provide for compulsory investigations, and in several others it is permitted under varying conditions. Twelve provide for the enforcement of an arbitration award when arbitration has been agreed upon by both sides. In 17 states the voluntary agreement to arbitrate must contain a promise to abstain from strikes and lockouts during arbitration proceedings, and two states, Colorado and Kansas, make strikes and lockouts unlawful and a ground for fines and imprisonment. The law of 1915 gives to the Industrial Commission of Colorado the power to compel a hearing in the case of an industrial dispute and to deliver an award which is not mandatory. As in the Canadian Industrial Disputes Act, change of terms of employment, strikes and lockouts are prohibited until after 30 days' notice and until after a hearing and award, if such hearing is started within the time of notice. Though it does not prohibit the right to strike, it delays the strike. Kansas, an agricultural state, by creating, in 1920, a Court of Industrial Relations, established compulsory arbitra-

tion. The law applies to industries connected with the manufacture of food products, clothing and wearing apparel in common use; to mining or the production of fuel; to transportation of the above-mentioned articles; and to all public utilities and common carriers, which are declared to be affected with a public interest and subject to supervision by the state. The court, which consists of three judges appointed by the governor for a three-year term, is authorized to summon the parties to a dispute before it, to investigate the conditions of the industry and to make a reasonable award. It may bring suit in the Supreme Court of the state to compel compliance with any of its orders. Either party, if aggrieved by an award, may sue in the state court to compel the Court of Industrial Relations to issue a reasonable order. Though the law recognizes the right of collective bargaining and the right of the individual to quit work, the right of labour to enforce its claims is forbidden. In the case of actual suspension or limitation of the operation of an industry, the court may take it over and operate it during the emergency.

**Federal Legislation.**—The Federal legislation on mediation and arbitration of 1888 and 1895 applying to common carriers has been superseded by three Acts: the Act of 1913 (the *Newlands Act*); section 8 of the Act creating the Department of Labor (1913); and title III. of the Transportation Act of 1920. The *Newlands Act* provided for the appointment of a Federal board for voluntary mediation and conciliation to consist of three members, a Commissioner and two other Government officials, appointed by the President with the advice and consent of the Senate. In four years this board functioned in 71 controversies, 24 of which were settled partly or wholly by arbitration and 52 by mediation. Failure of the Act, however, to meet the railway labour crisis in the fall of 1916 and again in March 1917 resulted in the first instance in Congressional action in the shape of the Adamson law granting the basic eight-hour day to trainmen, and in the second instance in the appointment by the President of a committee from the Council of National Defence to mediate. This meant, in effect, the breakdown of the *Newlands Act*, though it continued on the statute books subject to the limitation imposed on it by the Transportation Act of 1920. When the Government assumed control of the railways in Dec. 1917, a labour policy was immediately agreed upon. A Railway Wage Board was appointed to make recommendations to the Director-General, and a Division of Labor, headed by a brotherhood (union) official, was created to be the connecting link between employees and officials on the one hand and the Railway Boards of Adjustment. Later a permanent Advisory Board on "Railway Wages and Working Conditions" was created. Successive orders of the Director-General formulated a liberal labour policy, and machinery for handling disputes under these orders was established in the form of three Boards of Adjustment, composed equally of representatives of the administration and the workers. A similar policy was adopted in the Transportation Act of 1920, which makes it the duty of the railways and their employees to "exert every reasonable effort and adopt every available means to avoid any interruption to the operation of any carrier" growing out of any dispute involving grievances, rules or working conditions. In case a dispute arises, it is to be decided, if possible, in mutual conferences of representatives of each side. Disputes that cannot be settled in this way are to go before Railway Boards of Labor Adjustment which may be established by agreement between any road or group of roads and the workers. Except for a stipulation that these boards must contain representatives of organized labour, their size and composition are left to the discretion of the parties concerned. Matters may come before the Adjustment Boards either upon application by the road or the organized workers affected, or upon written petition of a hundred organized workers, or upon the board's own motion or upon the request of the Railroad Labor Board. This last-mentioned board is set up by the Act as the final tribunal for the settlement of railway labour disputes. It is composed of nine members appointed by the President with the advice and consent of the Senate to represent in equal proportion the workers, the employers and the public. During their five-year term of office, members of

the board must not be active members or officers of labour organizations or hold stocks or bonds of any carrier. Disputes may come before the Railroad Labor Board either upon failure of Adjustment Boards or directly. A majority vote is all that is necessary to constitute a decision except on matters taken up directly, in which case one of the members representing the public must concur in the decision. It has power to suspend any decision on wages made by the initial conference if, in its opinion, such a decision involves increases in wages or salaries which would necessitate a substantial readjustment of rates. In such cases the board must, after hearings, affirm or modify the suspended decision, and must also hold hearings on alleged violations of decisions and publish its decisions.

The Act of March 4 1913, creating a Department of Labor, provides that the Secretary of Labor shall have power to act as mediator and to appoint commissioners of conciliation in labour disputes, whenever in his judgment the interests of industrial peace require it to be done. In case mediation fails, arbitration may be proposed by the mediators, who cannot act as arbitrators. During the five years inclusive, 1915-9, the Secretary of Labor took cognizance of 3,644 cases and effected 2,559 adjustments. During 1910 alone 1,780 assignments of commissioners of conciliation resulted in 1,223 adjustments. In addition to the direct efforts of the Secretary of Labor, two other Boards of Labor Adjustment were established as part of the war machinery of the country.

The President's Mediation Commission was appointed in the fall of 1917 to conduct an investigation into the underlying causes of labour unrest which was threatening the output of material needed for war industries and to make specific adjustments. The Secretary of Labor was appointed as Chairman of the Commission. It made investigations in the copper mines of Arizona, the California oil-fields, the Pacific Coast telephone dispute, the unrest in the lumber industry of the north-west, and the packing industry. Settlements were made in all disputes except in the lumber industry, generally after arbitration had failed. In Jan. 1918, the Secretary of Labor upon nomination of representatives of capital and labour appointed a War Labor Conference Board to devise a method of labour adjustment which would be acceptable to employers and workers.

As a result of the Conference Board's report, the National War Labor Board was created by Presidential proclamation in April 1918. The membership consisted of two joint chairmen, five representatives of employees' organizations and five representatives of employers' organizations. As stated in the Proclamation, its powers and duties were "to settle by mediation and conciliation controversies arising between employers and workers in fields of production necessary for the effective conduct of the war, or in other fields of national activity, delays and obstructions in which might, in the opinion of the National Board, affect detrimentally such production" and to provide necessary machinery for these purposes. Its authority did not extend to controversies between employers and workers in any field of industrial or other activity where there was by agreement or by Federal law a means of settlement which had not been invoked. This provision excluded from the jurisdiction of the Board, except by way of appeal, a large group of cases. The ship-building industry had set up by agreement its own Labor Adjustment Board; the Ordnance Department and other producing departments of the Government had created special industrial service sections to consider the complaints of their employees; the coal-mining industry had its labour policy controlled by agreement of all parties with the Fuel Administration and the Government had adopted a separate labour policy for the railways. The statement of principles and policies contained in the report, which governed the decisions and which became an official expression of the Government's labour policy, was as follows: (1) abolition of strikes and lockouts during the war; (2) equal right of employers and workers to organize without discrimination; (3) right of collective bargaining; (4) observance of the *status quo ante bellum* as to union or open shop in a given establishment and as to union standards of wages, hours and other conditions of

employment, except that the War Labor Board might grant improvements in labour conditions as the situation warranted; (5) maintenance of established safeguards and regulations for the protection of the health and safety of the workers; (6) payment of equal wages for equal work to women in industry and allotment of tasks proportionate to their strength; (7) recognition of the basic eight-hour day in all cases in which existing laws required it, in other cases settlement of the question of hours with regard to Governmental necessities and the welfare, health and proper comfort of the workers; (8) maintenance of maximum production; (9) regard to be had for labour standards, wage scale and other conditions prevailing in the localities affected, in fixing wages, hours and conditions of labour; (10) right of all workers to a living wage which insures subsistence of the worker and his family in health and reasonable comfort. Provision was made for the settlement where possible by local mediation and conciliation and in event of failure of local machinery, for hearings before the National Board. When the National Board found it impossible to settle the controversy, provision was made for the appointment of an umpire by the National Board or by the President from a panel of disinterested persons. In the enforcements of its awards, the National War Labor Board had no special legal sanction or penalty either to force any party to submit disputes to arbitration or to enforce its awards. So outspoken however was public opinion on the necessity of avoiding interruptions in the war industries and so far-reaching were the wartime powers of the Government over both the employers and workers, that the indirect powers of the Board were sufficient. In only three cases were the Board's awards resisted. In two instances where the employers discriminated against the union employees and refused to abide by the decision in favour of the men, the President was sustained by Congress in taking over the industries. In the case of the strike by the organized workers at Bridgeport, Conn., against the Board's award, the President's threat of unemployment enforced by Governmental agencies compelled the men to return to work.

Besides legislative programmes, the Federal Government has made several other attempts to devise plans for the adjustment of labour disputes. In 1913 President Wilson appointed the Industrial Relations Commission to diagnose the cause of industrial unrest, and in the fall and winter of 1919 he appointed two industrial conferences to formulate a reconstruction labour policy. None of the programmes suggested has been given practical application. Experience during the war demonstrated the possibility of successful Government intervention in industrial disputes through mediation. Even voluntary arbitration was resorted to only in a few instances. Legislation was still needed in 1921 to extend the field of Federal mediation with regard to disputes involving agencies of interstate commerce and disputes so vital and comprehensive in extent that existing state agencies are unable to meet the situation. Though the Secretary of Labor is empowered to intervene in such cases, his intervention introduces political and trade union partizanship, which is objectionable to the parties to the dispute. The rapid increase of state agencies has created the need for co-operation between the state and Federal agencies. (For collective bargaining and arbitration in private industries see TRADE UNIONISM.)

*Bibliography.*—John R. Commons and John B. Andrews, *Principles of Labor Legislation* (1920); U.S. Bureau of Labor Statistics, *Bulletins*, Nos. 148, 166, 186, 213, 244, 257; U.S. Bureau of Labor Statistics, *Monthly Labor Review*; U.S. Secretary of Labor, *Annual Reports*; *American Labor Legislation Review*, Annual Summaries; U.S. Board of Mediation and Conciliation, *Report under Newlands Act*, Dec. 1917; Alexander M. Bing, *War-Time Strikes and their Adjustment* (1921). (J. R. Co.)

**ARBUTHNOT, SIR ROBERT KEITH, 4TH BART.** (1864-1916), British sailor, was born March 23 1864, and succeeded his father, the 3rd bart., in 1889. He entered the navy in 1877 and was promoted commander 1897, captain 1902 and rear admiral in the 2nd Battle Squadron 1913. Early in the World War he took over the 1st Cruiser Squadron and led it in the battle of Jutland, flying his flag in the "Defence," which was sunk with the loss of all on board May 31 1916.

ARCH, JOSEPH (1826-1919), British labour leader (see s. 349), died at Barford, Warwick, Feb. 12 1919.

**ARCHAEOLOGY: EGYPT AND WESTERN ASIA.**—During 1920-20 advances in Egyptian archaeological knowledge were sure if slow. Of course, generally speaking, less advance was made than in many previous decades, owing to the interregnum caused by the World War, when all British, French, German, and Austrian work was held up, and only the Americans and to a lesser degree the so-called "Egyptian" Service of Antiquities (manned by French and English) did any digging at all; while in all the European countries the energies of all the archaeologists who were not superannuated were transferred to the field of war, and there was no time left to write little papers, still less big books. And several, especially in France and Germany, made the great sacrifice which summarily closed lives and extinguished brains of great value to science. Nevertheless, advance was made.

In the years immediately preceding the war we have to chronicle first a great advance in our knowledge of the beginnings of Egyptian history, owing mainly to the excavations of Prof. Flinders Petrie at Tarkhan<sup>1</sup> and of the German, Prof. Junker (working for Austria), at Tura.<sup>2</sup> Both these places are in Middle Egypt, well N.; the former being near Kafr 'Ammar and the other just S. of Cairo, on the way to Helwan. The point of interest is that their diggings have shown that the Horus kings of Upper Egypt had under the "Scorpion King" (who is not the same person as Narmer or Narmerza, as we now must call him) extended their rule as far as the apex of the Delta, N. of Cairo. The Delta was presumably still independent, and was conquered by Narmerza. A point of importance as to the prehistoric period was scored by the discovery in the same neighbourhood at Gerzeh by Mr. Wainwright of iron beads on a necklace.<sup>3</sup> Now as these beads are admittedly worked metallic iron and must date before 4000 B.C., it is obvious that they are a remarkable confirmation of those who, like the present writer, have in opposition to Prof. Montelius always maintained that iron was known to and occasionally used in a worked state by the Egyptians at a period long anterior to its general introduction and replacing of bronze for weapons and tools.<sup>4</sup> The Old Kingdom finds of iron are now seen to be nothing very extraordinary. But equally it is now impossible to cast any doubt upon them. The oldest iron weapon known was hitherto supposed to be an Egyptian halbert-head of the time of Rameses III., but Mr. Randall MacIver has recently discovered in a tomb of the XII. dynasty at the Second Cataract an iron spearhead which is eight centuries older; dating from about 2000 B.C.<sup>5</sup> Iron was in fact both worked and used sporadically long before the "Iron Age."

Interesting conclusions as to the early ethnology of Egypt have been derived from the systematic examination of the necropolises of Nubia, necessitated by the heightening of the Assuan dam, as a consequence of which the northern portion of the valley S. of the dam became flooded, so that a complete examination of the archaeology of the district had to be carried out in order to save historical evidence from destruction. The results published in the *Archaeological Survey of Nubia*<sup>6</sup> by Messrs. Reisner & Firth have shown that the early culture of Nubia was closely akin to that of the predynastic Egyptians, which no doubt came from the south. After Egypt proper was overrun by the "dynastic Egyptian" people of "Armenoid" stock, who came from Asia and founded the kingdoms of Lower and Upper Egypt, the old barbarous Nilotic culture continued to exist in Nubia. We find an illustration of this in the fact that a red and black pottery, obviously akin to the predynastic Egyptian, but of finer make, was manufactured in Nubia in the time of the XII. dynasty, and introduced into Egypt by Nubian colonists, perhaps soldiers or enslaved prisoners, who preserved also their own native (and really old Egyptian) burial customs, interring their dead in "pan" graves much resembling those of the primitive Egyptians of two and three thousand years before.

Evidence is accumulating, though no completely satisfactory theory can yet be put forward, as to the northern origin of the

dynastic Egyptians. Elliot Smith has shown<sup>7</sup> the existence of the two racial stocks in Egypt, the predynastic Nilotic and the invading "Armenoid" from Asia, the man of higher cranial capacity to whom the blossoming of the Egyptian civilization and art out of primitive African barbarism is to be ascribed. This "Armenoid" stock must have come from Asia and, no doubt, reached Egypt by the Isthmus of Suez, but whence it came originally we do not know. Whether it was really Semitic we also do not know: whatever its skull may be its facial type is certainly not Semitic, whether of the fine pure Arab or the coarse big-nosed "Hethitized" types. It is sometimes almost central European in look.

How to equate this foreign civilizing race from Asia with the Semitic elements in the ancient Egyptian speech we do not yet know. It may be that these belong in reality to the old Nilotic inhabitants, who were probably related to the true Semites of Arabia; but the hieroglyphic system seems to have developed in the Delta, and is very probably to be ascribed to the "Armenoids." The Osiris cycle of legends seems to belong to these people. Osiris and Isis are closely connected with Syria and the Lebanon in legend; the *Deh* or sacred pillar of Osiris is doubtless really a representation of a great cedar with its horizontally outspreading branches;<sup>8</sup> another of the sacred Egyptian trees is obviously a cypress; corn and wine are traditionally associated with Osiris, and it is probable that corn and wine were first domesticated in Syria, and came thence with the gods Osiris and Re (the sun god of Heliopolis) into the Delta. Syria in fact is beginning to take shape in our minds as perhaps the most ancient seat of civilization in the world, the common source from which Babylonia and Egypt derived those items of culture in which, in the early period, they resemble one another. It remains for excavation to show whether this hypothesis is or is not correct. And the question whether the "Armenoid" conquerors of Egypt and founders of the kingdoms there, who came from Syria, were Semites still remains unanswered. If they were Semitic speakers, the present facial contours of the northern Semites, which have spread all over the world, are not Semitic at all: for the Egyptian Armenoids in the statues of the Old Kingdom look like Europeans, and must have been of "European" blood.

These new probabilities open up considerable possibilities in research with regard to the relations of the early Minoans and other Aegeans with Syria and Egypt and the undoubted fact of the resemblances of Minoan on the one hand to Syrian and Egyptian religions and funerary practices, and on the other hand to those of the Etruscans.

The facial contours of the modern Jew are predominantly those of the ancient Hittite, who was certainly not a Semite. One has hitherto supposed that he was related to the Mediterranean race, the race to which the Bronze Age Greeks and Italians belonged; but this supposed connexion may well break down in the matter of skull form, as the Hittite skull, like that of the modern Anatolian, probably inclined to be brachycephalic, whereas that of the Mediterranean inclined in the other direction. And now the Bohemian Assyriologist Prof. Hrozný has brought forward evidence<sup>9</sup> that the cuneiform script adopted by the Hittites from the Mesopotamians expressed an Indo-European tongue, nearly akin to Latin! This conclusion is not yet universally accepted, but it seems difficult on the evidence to avoid the conclusion that Prof. Hrozný is right, and if so the curious resemblances of some of the externals of Roman and Hittite religion, and the legendary and other connexions between the Etruscans and Asia Minor, are seen in a new light.

If the Hittites were Aryans, one can hardly suppose a primeval Aryan element in Anatolia. The Indo-Europeans whom we find in Mesopotamia (the Kassites and Mitanniens)<sup>10</sup> and in Palestine about 1400 B.C. can hardly have entered western Asia before 2000 B.C. or thereabouts, and it is probable that the Hittites belonged to the same wandering. On entering

<sup>9</sup>The fact that the Mitanniens venerated Varuna, Indra, and the Asvins is important as showing that Iranian and Indian Aryans had not yet separated as late as 1400 B.C.

Anatolia they probably found the land at least as far W. as the Halys already occupied by Semites. This Semitic population in Anatolia is an important recent discovery. At the time of the great dynasty of Ur (c. 2400 B.C.) in Babylonia, the whole Argaean region was occupied by these Semites, who seem to have been most kin to the Assyrians. They were no doubt expelled or absorbed by the Hittites, but we have the proof of their existence and of the fallacy of the statement that the Semite never crossed the Taurus, in the cuneiform tablets written in their language which have been found near Kaisariyeh and are now being published by various scholars.<sup>10</sup> No doubt the Hittites learnt the use of cuneiform from these people. Whether the national hieroglyphic system of the Hittites expressed the same Indo-European language as, according to Hrozný, their cuneiform does, we do not know, as further attempts to elucidate it made by Campbell Thompson<sup>11</sup> and Cowley,<sup>12</sup> while in themselves very interesting experiments, do not seem to take us further than previous attempts by Sayce and others. The supposition that the hieroglyphic system belongs to a late age, because it is chiefly found in the 10th and 9th century monuments of Carchemish, is improbable, as it bears all the characteristic marks of Hethitic nationalism, and is evidently a native invention. No people would have abandoned cuneiform for such a clumsy method of writing.

The excavation of Carchemish, lately suspended owing to political uncertainty in Syria, has been very interesting. The palace with its great relief-lined court and its water-gate of Hittite construction, the later Assyrian fortress, and the Hittite tombs with their characteristic pottery, are important results, and the whole work has been one of the major excavations of the last ten years, and has been fitly carried out by the British Museum, under the direction of Dr. Hogarth and Mr. Woolley.<sup>13</sup> The excavations of Dr. Garstang for the university of Liverpool at Sakchegözü,<sup>14</sup> further N., not far from Sinjirli, the seat of earlier German work, have also produced interesting results. The peculiar characteristics of Syro-Hittite art, and its relation to that of Assyria, are matters of great interest to the student of the civilization and art of the Nearer East. Equally interesting are the relation of the Syro-Hittite with the Minoan, and we seem to find in certain objects found in Egypt and Cyprus and dating probably from the 14th to the 10th centuries, proof of the existence of a mixed art of Syrian origin, probably in Cilicia (Alashiya) at that time.<sup>15</sup> Baron Oppenheim's excavations at Tell Halaf have resulted in the recovery of reliefs of barbaric style, simulating the Syro-Hittite, from the palace of a local king, Kapara, of about the same period as Sinjirli and Sakchegözü (10th-9th centuries B.C.), and pottery of all ages, going back to the chalcolithic period.<sup>16</sup>

The neolithic and chalcolithic pottery of Mesopotamia and Persia is one of the chief archaeological discoveries of late years in the Near East, and attention has recently been directed to it again by the important finds at Abu Shahrein (the ancient Eridu) and Tell el 'Obeid, near Ur. The excavations carried out for the British Museum at Shahrein by R. C. Thompson in 1918<sup>17</sup> and by Hall in 1919, and at El 'Obeid by Hall in the latter year,<sup>18</sup> have shown us that the painted ware of Susa and Musyan, discovered by de Morgan was not confined to Persia, but was the ordinary pottery of Babylonia in the prehistoric (chalcolithic) period. It seems characteristic of the neighbourhood of the gulf; the French excavations at Bandar Bushir<sup>19</sup> on the Persian coast have revealed exactly similar ware. And small finds of it on other sites have shown that it was usual all over Mesopotamia, and connects on the one side with the early pot fabrics of Asia Minor and on the other with the pottery of Anau and the *kurghans* of Turkistan, found by Pumpelly.<sup>20</sup> Its place of origin is not yet known. Rostortzeff in his article drawing attention to the undoubtedly Sumerian or sumerizing "Treasure of Astrabad"<sup>21</sup> in N. Persia (which, it must not be forgotten, may have been an importation from Babylonia and not local art at all), seems to think a northern origin as probable as any other. But as a matter of fact an exclusively Elamite origin is not improbable, from the fact that its earliest and first types are

found at Susa. Whether we should deduce from its common occurrence in Babylonia the existence of an Elamite population there in early times, later displaced by the Sumerians, we do not know. Sumerian pottery is different, but there are traces of a transition period. One thing, however, is pretty certain, and that is that the enormous dates B.C. assigned to it by de Morgan and Pumpelly cannot be accepted.

An argument for discontinuity of race is found in the fact that whereas the Sumerians are never represented as using the bow, their predecessors certainly made flint arrowheads. The stone knives, arrowheads, celts, hoe-blades, hammers, nails, awls, etc., associated with this pottery are of kinds which though simple and often crude in type are nevertheless not early, but date from the transition period to the age of metal and the earliest centuries of the latter period. Flint and chert were employed for knives, etc., but with none of the marvellous skill and artistry of the predynastic Egyptian flint-knapper; the early Babylonian used comparatively simple flakes and the wonderful serration of the Egyptian knives was unknown to him though he made the saw-blades. Obsidian and rock crystal were also used for knife making. Celts, of the usual late neolithic type, were generally of green jasper; hoe-blades (looking almost exactly like palaeolithic *haches à main*) of chert or coarse limestone; hammers of granite; mace-heads, of identical type with the early Egyptian, of diorite and limestone; nails of obsidian or smoky quartz, often beautifully made. All these stones were of course imported, as the Babylonian had no stone (except a rough coral rag) at hand as the Egyptian had. And many must have come from far afield. In later days, in the time of the Sargonid kings of Akkad or the monarchs of Ur, stones such as granite, basalt, diorite and dolerite were probably brought from the Sinaitic peninsula, if not from the western desert of Egypt, if the Red Sea coast is to be identified, as seems very probable, with Magan, "the place to which ships went," the land whence the Babylonians got some of their first stones for sculpture and architecture. Magan originally was probably a land on the S. coast of the Persian Gulf, but as the early navigators pushed their voyages further, the ships rounded the coast of Arabia, and came into the Red Sea, and the names of Magan and the neighbouring Melukkhka gradually extended westward, with the result that in late times to the Assyrians Melukkhka meant Ethiopia. Magan, however, probably never meant Egypt proper, the Nile land itself, or Egypt, would have been called *Magan* by the Assyrians in later times; it was called *Musri* then and probably in early times also. So that we are not disposed to accept a recently propounded theory<sup>22</sup> that a certain King Manium of Magan who was overthrown by the Akkadian king Naram-Sin about 2850 B.C., was none other than Menes, the earliest king of Egypt, who is generally identified with Narmerza. "Manium" is a common Semitic name. We need not even suppose that this Manium was a chief of the Egyptian Red Sea coast or even of Sinai. The Magan of which he was king need have been no further afield than the Oman peninsula. And the whole equation seems to break down on the matter of date, as it is quite impossible to bring Narmerza down to 2850 B.C. Naram-Sin was in reality a contemporary of the kings of the V. dynasty.

The question how far connexion was kept up between early Egypt and Babylonia by way of the Red Sea or across the desert is a very interesting one. An important piece of evidence on this point has recently come to light in the shape of the carved hippopotamus-tusk handle of an Egyptian predynastic stone knife, said to have been found in the Wadi el 'Araq, on the right bank of the Nile opposite Nag'Hamadi, and now in the Louvre.<sup>23</sup> On this remarkable object, which is certainly of predynastic Egyptian date (before 3500 B.C.), we see representations of early Egyptians and perhaps other tribes fighting, with ships, some like those represented on the Egyptian predynastic pots and others different, with high prows and sterns, and we also see a strange deity of Babylonian aspect. He is not identical with any known Babylonian deity, but he is the god of a people belonging to the Babylonian culture circle, probably of the inhabitants of the Red Sea littoral. The object is of Egyptian



workmanship, representing this powerful deity of the foreign sea people with whom the predynastic Nilotes no doubt often fought. This, by the way, points to the conclusion that Babylonian (Sumerian) culture and art were considerably older than the Egyptian; but we have no definite evidence yet on this point.<sup>24</sup>

Later points of artistic connexion may be seen when we compare the well-known bronze statues of Pepi I. and his son found at Hierakonpolis by Quibell with the copper lions discovered at Tell el 'Obeid near Ur by Hall two years ago.<sup>25</sup> Dr. Reisner is of opinion that copper was first used in Egypt, and bronze certainly seems to have been used there first. The lions of 'Obeid date from about the Ur-Nina period of Babylonian history, i.e. about 3000 B.C. or a century or two earlier; the Pepi statues are two or three centuries later. We see however the similarity of the metal-working of both countries at approximately the same time; both are in the same style of artistic development, the Egyptian perhaps the more advanced of the two, and (if the published analysis by Mosso is to be relied upon) with the additional technique of the alloy with tin, making the metal bronze, and so easier for the heads to be cast. The Sumerians cast the heads of their lions in copper, not always with successful results, and filled them with bitumen and clay (like the image in "Bel and the Dragon," which was "clay within and brass without") to give them solidity. The bodies (or so much of them as ever existed, as only the fore parts remained) were hammered and wrought, like the bodies of the Egyptian figures. The eyes in both cases were inlaid, those of the lions with red jasper, white shell and blue schist: this imitation of the eyes in stone as well as metal figures was a feature common to both arts, which were at this time assuredly not without direct or indirect connexion. Whence the Egyptians and a little later on the Babylonians got their tin for the alloy we do not yet know.

The question as to whether copper really was first used in Egypt is not yet resolved, and many arguments can be brought against the theory of Egyptian origin and in favour of one in Syria or further north.<sup>26</sup>

Egypt has also recently been credited with being the inceptor of the whole "megalithic (or heliolithic, as the fashionable word now is) culture" of mankind, from Britain to China and (literally) Peru or at any rate Mexico via the Pacific Isles.<sup>27</sup> The theory is that the achievements of the Egyptians in great stone architecture at the time of the pyramid-builders so impressed their contemporaries that they were imitated in the surrounding lands, by the Libyans and Syrians, that the fame of them was carried by the Phoenicians further afield, and that early Arab and Indian traders passed on the megalithic idea to Farther India, and thence to Polynesia and so on so that both the teocalli of Teotihuacan and Stonehenge are ultimately derived through cromlechs and dolmens innumerable from the stone pyramid of Saqqara, built by Imhotep, the architect of King Zoser, about 3700 B.C. (afterwards deified as the patron of science and architecture). This theory of Prof. Elliot Smith's is very plausible and "fascinating," but whether it will prove to be true remains to be seen. The Babylonians apparently refused to be impressed by the Egyptians in this matter, and went on building temples in brick, probably for the good reason that they could not get any stone. The only stone building in southern Babylonia is the town wall of Eridu (Abu Shahrein), which is built of rude humps of a local coral rag.<sup>28</sup> The granites and dolerites from Magan were too fine and too expensive to build with.

Megalithic town walls were naturally common in that stony land, Palestine, and very typical specimens of them were found in the Palestine Exploration Fund's excavations at Bethshemesh ('Ain Shems) directed by Dr. Duncan Mackenzie,<sup>29</sup> whose work also threw new light on the phenomenon of the appearance in Palestine between the 13th and 10th centuries B.C. of sub-Mycenaean (Greek) pottery, which can only be ascribed to the Philistines, whose historical position as a foreign invading force from the Aegean area (Lyca and Crete-Kaphtor) is now entirely vindicated.<sup>30</sup> Another important excavation in Palae-

tine in the period preceding the World War was that of Dr. Reisner at Samaria, which is not yet fully published. Very interesting examples of Israelite written inscriptions on potsherds, dating from the 9th century B.C. and probably from the reign of Ahab, were found that are of great palaeographical importance.<sup>31</sup> Continued work at Samaria should reveal some trace of the civilization of Israel, which we know was considerable, unless the devastation of the Assyrian sieges has destroyed it all. This is possibly the case with regard to the older culture of Canaan in the preceding millennium, of which Palestinian excavations have yielded few traces, though we know it existed.<sup>32</sup> War destroyed it: Palestine was the cockpit of Asia. An interesting discovery seems to have been made in the identification by Drs. Gardiner and Cowley of the earliest Semitic script in the hieroglyphic signs found in Sinai.<sup>33</sup>

Since the war a new British school of archaeology in Jerusalem has been founded under the direction of Prof. Garstang, who has begun for the Palestine Exploration Fund excavations at Ascalon, which have resulted in the discovery of interesting late buildings<sup>34</sup> and this year (1921) in that of a statue of Herod the Great. It is to be hoped that continued work will discover traces of the Philistine period at Ascalon, and relics of the same age will no doubt be discovered at Bethshan (Beisan), for a time the furthest eastward outpost of the Philistines, which is about to be explored by the American School at Jerusalem. The new conditions in Palestine should be very favourable to archaeological work there, and it is to be hoped that in Syria the French will give every facility for international work.

The future of archaeological study in Mesopotamia depends upon the political conditions, which have not hitherto been considered favourable to the resumption of excavation in that country. The great German excavations at Babylon<sup>35</sup> and Assur (Qal'at Sherqat),<sup>36</sup> under the direction of Koldewey and Andrae, will probably not be resumed for many years. They were admirable work, and at Sherqat especially have produced results of the greatest historical and archaeological importance. We now know something of the early history of Assyria and of the succession of Mer kings from monuments found at Sherqat. It is not, however, proposed to give here a list of the newly discovered names<sup>37</sup> of the Babylonian kings on tablets from Nippur, published by Poebel<sup>38</sup> and others, as results of this kind belong to the realm of history rather than to that of archaeology. The new series of "Creation" and "Deluge" tablets from Nippur, published by Poebel & Langdon,<sup>39</sup> also belong to the realm of the historian and anthropologist rather than to that of the archaeologist, so are merely mentioned here; the excavation in which they were found being now ancient history. In Mesopotamia more than any other country literary results have been regarded as archaeology, owing to the enormous mass of the written material recovered, which has caused the study of the art and general civilization of different periods to be neglected in comparison with the same subjects in Egypt.

In Egypt the succession to the work of the *Deutsch-Orient Gesellschaft*, which excavated Babylon and Assur, has fallen to the Egypt Exploration Society, which has taken up the excavation at Tell el Amarna where it was laid down by the Germans at the outbreak of war, after they had recovered from the house-runs several wonderfully fine examples of the art of the period of Akhenaton, now in Berlin.<sup>40</sup> The first season's labour, under the direction of Prof. T. E. Peet, resulted in interesting discoveries, some of which tend to show that the cult of the Aten or Solardisk was not so rigidly enforced by the heretic king Akhenaton as has been supposed, and that ordinary people were allowed to worship other gods than the sun-disk, at any rate in connexion with funerary ceremonies. The great excavation of the Osireion at Abydos, begun for the Society (then the Egypt Exploration Fund) by Prof. Edouard Naville,<sup>41</sup> but suspended owing to the war, it has not been possible to resume at present, owing to the commitments of the Amarna site and the heavy expense of such work as that at the Osireion, which cannot yet be contemplated. This building, the date of which is not yet finally settled, though its excavator believes it to be of the Old

Kingdom like the temple of the Sphinx at Giza, is one of the most remarkable in Egypt, and the completion of its excavation is much to be desired. For such a work, however, considerable funds are necessary, and all archaeological study has had to struggle along with insufficient means.

Prof. Petrie resumed operations in Middle Egypt after the war, and made interesting discoveries (1921). By the autumn of 1921 conditions for work were improving.

Dr. Reisner, working for Boston, was not held up by the war, but continued his excavations in the Giza pyramid field and in Nubia, making good finds in both places. His determination from the study of their pyramids at Napata (the Barkal region) of the succession of the Ethiopian kings,<sup>62</sup> and his revelations of the colonial dominion of the Egyptians in Nubia under the XII. dynasty, derived from his work at Kerma and Defufa,<sup>63</sup> are of great historical importance.

Other work of importance in Nubia immediately before the war was that of Mr. Randall MacIver and Mr. Woolley for the Eckley B. Coxe (Philadelphia) Expedition,<sup>64</sup> that of Oxford at Farras, directed by Mr. F. U. Griffith,<sup>65</sup> which has resulted in an unrivalled series of Nubian pottery from the earliest to the latest times, and that of Prof. Garstang at Merôë,<sup>66</sup> in the far S., which has shown us a barbaric culture of Egyptian origin, strongly influenced by the Ptolemaic and Roman civilization of its time: this is the culture of the Candaces. The great bronze head of Augustus Caesar, now in the British Museum, is one of the trophies of this excavation, and is very interesting as being either a trophy of war carried off perhaps from Syene, or was actually set up at Merôë by the independent native ruler in honour of the Emperor. Mr. Griffith has added to our knowledge of the ancient languages of the world by his interpretation of the Merottic inscriptions,<sup>67</sup> to which Prof. Sayce has also contributed.<sup>68</sup>

Returning to the N. and early times again, we have to chronicle besides Reisner's excavations,<sup>69</sup> those of the university of Pennsylvania (Eckley B. Coxe Expedition),<sup>70</sup> and of Junker for Vienna,<sup>71</sup> all in the pyramid field of Giza. These explorations of the *mastaba* tombs of the III.-VI. dynasties have had interesting results. Among other important archaeological finds of the past decade are those of several new fragments of the "Palermo Stone" and similar annalistic monuments of the V. dynasty,<sup>72</sup> which are of high importance for the early period. The New York Museum has further investigated the Middle Kingdom pyramid field at Lisht and its neighbourhood,<sup>73</sup> and Prof. Petrie and Mr. Brunton have found fine XII. dynasty jewellery at Lahun<sup>74</sup> (now in New York). At Thebes, New York has also carried out work at Qurnet Murra<sup>75</sup> and Sheikh 'Abd el Qurna, as well as at Dra' Abul Neqqa and Deir el Bahri,<sup>76</sup> where the Earl of Carnarvon, assisted by Mr. Howard Carter, has also dug with remarkable success, recovering some of the most beautiful relics of the art of the XII. and XVIII. dynasties that we possess.<sup>77</sup> Among other tombs Lord Carnarvon has found the long-sought sepulchre of Amenhotep I.<sup>78</sup> At Thebes important work in the copying of tombs has been done by Mr. and Mrs. de Garis Davies for Dr. A. L. Gardiner, who publishes with them the tombs of Amenemhet and Antefoker, under the auspices of the Egypt Exploration Society.<sup>79</sup> The French Archaeological Institute at Cairo has also excavated Theban tombs<sup>80</sup> and at Dendera a naos of the XI. dynasty, with interesting sculptures of Neb-hepet Re (the king whose tomb temple at Deir el Bahri was excavated by Naville and Hall for the Egypt Exploration Fund in 1903-7) has been found, and taken to Cairo.<sup>81</sup> An interesting discovery of the late period in Upper Egypt, that of images and other temple objects of precious metals, was also made at Dendera by the diggers for natron (sebakh) and recovered by the *Service des Antiquités* for the Cairo Museum.<sup>82</sup>

Outside Egypt proper the work of editing and publishing all the Egyptian inscriptions of Sinai has been begun by Dr. Gardiner and Mr. Peet.<sup>83</sup>

A worthy completion of the record is the wonderful exhibition of all the finest examples of Egyptian art in Britain outside the

British and Ashmolean Museums, held by the Burlington Fine Arts' Club in London in the summer of 1921.<sup>84</sup>

**BIBLIOGRAPHY.**—(1) *Tarkhan I. and II.*, 1913-4; (2) *Denkschr. der kais. Akad. Wiss. in Wien., Phil. hist. Klasse*, LVI. (1912); (3) *The Labyrinth, Gerseh, and Masghunch*, 1912; (4) *Hall, Oldest Civilisation of Greece* (1901), p. 198; *Man*, Oct. 1903, 86, May 1905, 40; *Montelius*, *Maan*, Jan. 1905, 7; (5) *Buhen*, p. 193, pl. 88; (6) *Survey Dept.*, Cairo, 1908-11; (7) *The Ancient Egyptians* (1911); (8) This is the view of Mr. P. E. Newberry, with whom on early Egyptian connexion with Syria the writer agrees. (The only other serious explanation of the *Ded* is that of Sir E. Budge, who believes it to be a representation of the vertebrae of Osiris, which would be a holy relic); (9) *Heitische Studien*, I., II., Berlin, (1916-9); (10) *Contenau, Trente Tablettes Cypariotiennes* (1919); S. Smith, *Cuneiform Texts from Cypriote Tablets in the British Museum*, 1921; (11) *Archæologia*, LXIV.; (12) *The Illites* (Schweich *Lectures*, 1918); (13) *Hogarth, Carcemish I.*, 1914; *Proc. Brit. Acad.*, V.; *Woolley, Ann. Anthr. Arch.*, Liverpool, IV, 87 ("Hitrite Burial Customs"); (14) *Ann. Anthr. Arch. V.*; (15) *Hall, Manchester Eg. Or. Journ.*, 1913; (16) *Brit. Mus. North Semitic Gallery*; (17) *Archæologia*, LXX.; (18) *Proc. Soc. Ant.*, Dec. 1919; (19) *Pezard, Mém. Déleg. Pers.*, XV. (1914); (20) *Hall, Proc. Soc. Bibl. Arch.*, 1909, p. 311, ff. pl. 48, 49; *King, Hist. Sum. Akk.* p. 351, ff.; (21) *Journ. Eg. Arch.*, VII. (1920) p. 4, ff.; (22) *Allbright, Journ. Eg. Arch. ibid.*, p. 89, ff.; VII. (1921) p. 80, ff.; *Sayce and Langdon, ibid.*, VI. 295 ff.; (23) *Bénédict, Fond. Eug. Piot.*; *Mon. et Mém.*, XXII., I (1916); (24) *Hall, in Camb. Anc. Hist.* (forthcoming); (25) *Proc. Soc. Ant.*, Dec. 1919; *Camb. Anc. Hist.*; (26) *Camb. Anc. Hist.*; (27) "The Influence of Ancient Egyptian Civilization in the East and in America," *Bull. John Rylands Libr.*, Jan.-March 1916; (28) *Proc. Soc. Ant.*, Dec. 1919; (29) *Palestine Expl. Fund Annual*, 1911, 1912-3; (30) *Hall, Camb. Anc. Hist.*, 1921, p. 71, ff.; (31) *Lyon, Harvard Theol. Rev.*, Jan. 1911; (32) *Hall, Camb. Anc. Hist. Near East*, p. 441; (33) *Journ. Eg. Arch.* III. (1916); (34) *Pal. Expl. Fund Quarterly Statement*, April 1912, p. 73; (35) *Koldewey, Das wieder-erzehende Babylon* (1913); *Excavations at Babylon*, 1914; (36) *Andrae, Festungswerken v. Assur und Stelenreihe v. Assur* (Deutsch Orient-Gesellschaft, 1913); (37) *Schroeder, Zeits. Assyri.*, Dec. 1920, p. 32; (38) *Historical Texts* (Univ. Penna. Publ. IV., v., 1914); *King, Schweich Lectures*, 1916, p. 20, ff.; (39) *Poebel, loc. cit.*, *Langdon, ibid.*, X.; *Poeme du Paradis* (1919); *King, loc. cit.*, p. 52, ff.; (40) *Mitthe. der Deutsch Orient-Gesellschaft*, Nos. 55 (1914) and 57 (1917); (41) *Journ. Eg. Arch.* I. (1914), p. 159, ff.; (42) *Harvard African Studies*, II.; *Boston Museum Bulletin*, Feb. 1918; *Sudan Notes and Records*, II. 35, 237; (43) *Boston Museum Bulletin*, April 1914, Dec. 1915; (44) *Karanôg, 1910*; *Buhen*, 1911; (45) *Ann. Anthr. Arch.*, VIII. (1921) No. 1.; (46) *Merôë*, 1911; (47) *Griffith, in Merôë*, p. 58, ff.; *Karanôg, Merôitic Inscr.* 1911; (48) *Merôë*, p. 49, ff.; (49) *Boston Museum Bulletin*, Nov. 1913, April 1915; (50) *Phila. Mus. Journ.*, June 1915; (51) *Journ. Eg. Arch.* I. p. 250, ff.; (52) *Gautier Musée Égyptien*, 1915; *Gardiner, Journ. Eg. Arch.* III. p. 143, ff.; *Petrie, Anc. Egypt*, 1916; (53) *N. Y. Mus. Bulletin*, 1914, p. 207, ff.; (54) *N. Y. Mus. Bulletin*, Dec. 1919; *Brunton, Lahun I.* (1920); (55) *N. Y. Museum Bulletin*, 1918 (Supplements), 1920 (do.); *Journ. Eg. Arch.* VI. p. 220; (56) *Five Years' Excavations at Thebes*, 1912 and *Journ. Eg. Arch.* passim; (57) *Carter, Journ. Eg. Arch.* III. p. 147, ff.; (58) *Amenemhet*, 1915; *Antef-oker*, 1920; (59) *The Tomb of Nakhth* (1916); (60) *Gautier, Ann. du Service*, 1920, p. I., ff.; (61) *Darcsey, Ann. du Service*, 1917, p. 226, ff.; (62) *Journ. Eg. Arch.* V. p. 68; (63) *Inscriptions of Sinai*, I. (1917); (64) *Newberry and Hall, Catalogue of an Exhibition of Ancient Egyptian Art*; London, Burlington Fine Arts' Club, 1921. (H. H.)

**ARCHAEOLOGY: GREECE AND GREEK SITES.**—All important excavations which were in progress in Greek lands in 1911 came to an end with the beginning of the World War. These had not yet been resumed by 1921, partly because of the increased cost of labour, partly because of the continued inaccessibility of sites. The numerous minor explorations, however, chiefly carried on by Government authorities and local archaeological societies, had been less interrupted. Even the studies of individual members of the foreign schools and institutes had been to some extent continued by these scholars in the course of military service with one or other of the combatant forces in the Near East.

#### PREHellenic Period

The greatest advance during the decade 1910-20 was made in the knowledge of prehistoric Greece, to which increasing interest had been directed since the first discoveries of Sir Arthur Evans in Crete in 1900.

*Greek Mainland.*—Exploration of the Mycenaean sites of the Greek mainland have shown that beneath the characteristic painted pottery which is so plainly derived from the late Minoan wares,

there is no unbroken sequence of development such as is found at Cnossos and elsewhere in Crete: that is to say, the Mycenaean civilization was not native to Greece proper, but was imposed there in a mature form upon a more backward culture. The earliest Cretan settlements in Greece belong to the end of the third Middle Minoan period, about 1800 B.C. Pre-Mycenaean civilization in Greece varied in different localities. The results of researches on numerous prehistoric mounds in Thessaly were exhaustively published by A. J. B. Wace and M. S. Thompson in 1912. Sites have also been explored in Phocis (Hagia Marina) and Boeotia, in Aetolia (Thermon) and the Ionian Islands, in Attica, at Argos, Mycenae and Tiryns, in the neighbourhood of Corinth, and in the islands of Aegina, Cythera, Euboea, Melos, Paros, and Rhodes.

The results show that Thessaly was free from Cretan or other southern influence until the late Mycenaean period developed in isolation an advanced neolithic culture until the rest of Greece and the Aegean Ia. had come almost to the end of their age of bronze. Western Greece appears to have been more barbarous than Thessaly, and its outward connexions, if any, before the Mycenaean period, were with Italy rather than with Greece. South-eastern Greece and the Peloponnesus show (in their sequence of pottery fabrics): (i.) An Early Bronze Age culture (black-varnish ware, *Ufismis*) similar to that of the Cyclades and Crete but of meaner development, which was dominated in turn by (ii.) its more progressive neighbours of the Cyclades (dull-paint ware, *Malmaleret*) and perhaps of Asia (Minyan ware), and ultimately (iii.) of Crete (Mycenaean).

For the mainland cultures a new term "Hellenic" has lately been invented, and three chronological divisions, Early, Middle and Late Hellenic, are proposed to correspond with the parallel Cycladic and Minoan periods. Mycenaean pottery is found to contain elements which do not belong to Crete, but which must be attributed to the influence of the fabrics established in Greece before it. The same development is looked for in Mycenaean architecture. Early Hellenic house walls have lately been found by the American School at Corinth (A. W. Blegen, 1921). Prehistoric buildings of the semi-elliptical plan, which previously appeared beneath classical remains at Olympia and at Orchomenos in Boeotia, have now been discovered under the Mycenaean palace of Tiryns, under an Hellenic temple at Thermon in Aetolia and in Levkas.

This new and unexpected knowledge, and modern improvements in the science of excavation, have led to the reexploration of several old sites. Tiryns was dug again by the German Institute (until 1914), Phylakopi in Melos (1912) and the Kamarets Cave in Crete (1913) by the British School at Athens, who also began in 1920 a further excavation on the acropolis of Mycenae. What is chiefly sought by such revision is better evidence for the chronology and inter-relation of the different cultures, but much new information has been gained in regard to plan and structure of the palaces and fortifications of Mycenae and Tiryns. Fragments of painted wall and floor decoration have also been recovered on these sites. Those from Tiryns are a most remarkable series; the figure frescos which have been reconstructed represent women in procession, a chariot group and a boar hunt. A fresco bearing the figure of a woman holding lilies and a vase was also found in the "Palace of Cadmus" at Thebes (1916), where many Early Mycenaean graves were also excavated. Other discoveries at Tiryns were a beehive tomb, perfectly preserved and used throughout the classical period, some pottery vases which bear painted inscriptions in characters said to be derived from the Cretan script, and an accidental find of Mycenaean treasure in 1915 by a labourer employed in the agricultural school. This consisted of bronze swords and vases, gold jewellery with agate and other gems, bracelets, collars, a seal cylinder and two engraved gold rings, one of which, the largest known, bears a religious scene. Mycenaean pottery and a carved steatite vase were found in caves in the island of Cythera in 1915. The Italian occupation of Rhodes in 1911 was followed by a general exploration of the island, in the course of which some graves were opened in the Mycenaean cemetery of Ialysos, which had been dug in 1868-72, and important material is said to have been obtained. This should be useful for establishing the date and classification of the earlier finds, which are in the British Museum. Some Late Mycenaean remains have been found in association with products of the local culture in the Ionian Islands. Doerpfeld sees in the crude settlements in Levkas the works of Homeric Achaeans, and continues to identify the island with Ithaca. A search by rival theorists for evidence which will prove that Cephalonia is Ithaca, has produced nothing more convincing, and efforts to find the city of the Phaeacians at Cape Kephali in Corfu were also unsuccessful.

**Crete.**—In Crete there were many excavations in progress at the beginning of the war; at Tylisos (by the Greeks), Hagia Triada, Phaistos and Gortyna (Italians), Pachyrammos and other sites in eastern Crete (R. B. Seager and the American School). Sir Arthur Evans conducted supplementary excavations at Cnossos in 1912, and the British School reexamined the Kamarets Cave, where the typical Middle Minoan polychrome pottery were first found in Crete, in 1913. During the war only the Greek excavations were continued, and no foreign work has yet begun again (1921). Tylisos was the most productive site. Khatzidakis found there three large houses, each with some twenty rooms and upper storeys, and a unique collection of bronzes, an ingot, some enormous cauldrons, and a statu-

ette of a praying man. This curious figure served to identify a similar but much finer piece of unknown origin, which had lain for many years unrecognized in the British Museum. Another new bronze from Crete had been lately acquired (1921) by an English collector. It represents a man in the act of turning a somersault over the horns of a charging bull, a unique rendering of a familiar theme in Minoan art. Both these pieces were published in the new volume of the *Journal of Hellenic Studies* (1921). The Museum of Fine Arts at Boston also obtained in 1914 a masterpiece surreptitiously excavated and smuggled out of Crete, an exquisite gold and ivory statuette of the snake goddess or her votary.

The Kamarets Cave was found to be a sanctuary, not a dwelling, but the offerings consisted almost entirely of pottery of M.M. styles, and there were no specifically votive objects such as other cave sanctuaries have contained. The Italians at H. Triada in 1913 found a portico bordering a courtyard of the palace, a large deposit of inscribed clay tablets, and a well-preserved L.M. III. shrine. Two beehive tombs, said to be Early Minoan, were found near Phaistos. They had been plundered and were destroyed to within a metre of the ground, but still contained some pottery and stone vases, bronze blades, seals, and ivory fragments. At Gortyna the first prehistoric finds of neolithic and Minoan periods were made in 1913. The other discoveries on this site have been nearly all of Roman date. The so-called Odeum, a circular building in which the famous code was found, was completely cleared in 1912, and five small fragments of the inscription were recovered.

Minoan finds were made on several lesser sites: at Plati in the Laithi Plain in 1914, houses and burials; in eastern Crete at Sphoungaras in 1912, and at Pachyrammos in 1914. E.M. to L.M. cemeteries with numerous *pitthos* burials, at Damania, in 1915, an L.M. III. tomb of rectangular plan with converging walls closed at the top by a single course of stones. At Gourmes, near Cnossos, in 1914 an E.M. cemetery containing hand-made vases of strange fabric was opened by Khatzidakis, who also found in 1911 fragments of *buchero* cups, in a cave sanctuary at Arkalokhori near Lyttos. Similar grey pottery was found by Xanthoudidis in a large E.M. tomb at Pyrgo in 1918. Seager's brilliant discoveries at Mokhlos were published (with coloured plates of the Early Minoan stone vases) in 1912.

#### "GEOMETRIC" PERIOD

Remains of the still problematic transitional period of the Early Iron Age were found in Crete at Atsipada in 1912, and in a settlement at Vrokastro in 1912-3 (R. B. Seager and E. M. Hall). Several sites of the Early Iron Age have also been excavated in Greece, but nothing has been found to prove the origin of the "Geometric" culture, though accumulating evidence still indicates a northern source.

A Geometric cemetery was dug by the Germans at Tiryns, and their finds have been accurately published (1912). Some graves were opened at Eretria in Euboea in 1915. More important are the remains of buildings of this period. A temple built of sun-dried brick and timber has been found at Thebes underlying an archaic temple of Isemenian Apollo and standing on Mycenaean tombs (Keramopoulos, 1916), and a more extensive settlement was found at Thermon in Aetolia (Romaos, 1911-3). This lies similarly underneath an archaic Greek temple of Apollo, which was built apparently in the 7th century to replace the "Geometric" temple, an elliptical structure with an exterior ring of columns. Smaller elliptical houses were found near by, with geometric potsherds, bronzes, and a few iron weapons. Below again are Mycenaean and pre-Mycenaean settlements, with houses built of sticks and mud. The value of the site is its continuity from prehistoric to Hellenic times. The stratification is said to be like that of the settlements at Olympia, but undisturbed.

Halos was added to the number of Early Iron Age sites in Thessaly in 1912 (Wace and Thompson). A tumulus and cist graves were dug containing weapons, fibulae, and pottery of sub-Mycenaean type like that previously found at Theotoku. In Macedonia during the war some finds of the same period were made by British troops on mounds in the Vardar valley, and a cemetery was opened by the Y.M.C.A. at Chauchitsa (Causica) near Lake Doiran. These graves have been further examined since the war, and have yielded material which is said to connect with Thessaly and Hallstatt (S. Casson, 1921). Some bronzes from Chauchitsa are in the Royal Scottish Museum at Edinburgh.

#### CLASSICAL PERIOD

Recent excavations of classical sites in Greece proper have been of minor importance. At Argos, A. Vollgraff continued his researches, but found little besides inscriptions. These are always the most numerous finds on classical Greek sites, and their importance is mainly historical. New inscriptions and the general progress of Greek epigraphy have been minutely recorded from year to year by M. N. Tod in the *Journal of Hellenic Studies*.

**Greece.**—There has been most archaeological activity at Athens, where its results have been mainly topographical. The cemetery of Kerameikos outside the Dipylon Gate was being extensively excavated and restored, so far as possible, to its original 5th-century appearance by the German Institute in 1914. *Ostraka* inscribed with familiar political names were found in the course of the work. An examination of the Phnyx in 1911 showed that the supporting wall is no earlier than the 4th century. A search for the Odeion of Pericles in the south-east slope of the Acropolis was inconclusive. Some pieces of sculpture were found here, among them fragments of the Parthenon and a singular relief of Asclepius with a kneeling woman suppliant. Sculpture was also found in excavating the Stoa of the Giants and the Roman *agora*. A cemetery at Phaleron dating from the 7th century was examined. A curious find was a grave containing burials of eighteen men fettered with iron collars and shackles. At Sunium the west end, pediment, and roof of the temple of Poseidon was rebuilt with excavated fragments. A circular building identified (by Svoronos) as the Attic mint in the Peloponnesian War, was cleared, and a fine archaic relief of an ephoe crowning himself was discovered. A hoard of about 1,600 silver coins, found at Carditsa in 1914, was acquired by the National Museum of Athens. The coins are chiefly Theban, of all dates down to 315 B.C. There are about 100 archaic Aeginetan staters, and some other rare coins.

The important excavations of the American School at prehistoric sites near Corinth have been mentioned. Work in the city had been resumed after the war up to 1921; the last finds in 1914 were two colossal portrait statues of members of the Julio-Claudian family, perhaps Caius and Lucius Caesar. The re-examination of Delphi by the French School was still going on in 1921, but on a small scale, while the publication of the first discoveries, made in 1892, was still unfinished. Among other details, the interior arrangements of the temple were studied, and it was established that there was no natural cave, but an artificial recess in the sanctuary, of which the walls still remain. The excavator also claimed to have found the *omphalos* itself. The pediment sculptures were reconsidered with fresh fragments and a better knowledge of the *lympanon*, and a new restoration of the eastern group has been proposed (F. Courby, 1914). A popular but scholarly account of Delphi was translated into English from the Danish of F. Poulsen in 1920.

Halae in Locris was dug by Americans in 1911. The cemetery, extending from archaic Greek to Roman times, and the acropolis were explored. The sanctuary of Apollo Corynthos at Longas was excavated in 1911. Five temples were found, and, among small objects, a number of bronzes. Material for reconstructing the *megaron* or Hearth of Despoina was found at Lycosura. The monument was an open-air altar, a terrace with portico, dated about 200 B.C. Many votive terra-cotta statuettes were obtained, the commonest being the figure of a sheep dressed as a woman, erect with a basket on its head, no doubt a ceremonial costume of worshippers. In the Roman city of Nikopolis the temple built by Octavian to Mars and Neptune, in commemoration of the battle of Actium, was excavated in 1912, and fragments of its structure were recovered. Further examination of towers in the town wall of Pagasae (or Demetrias) led to the discovery of many more painted grave-stones, like those first found in 1907. The town was explored in 1912, and the cemetery from which the *stelae* came was found. The graves are mostly of the 3rd century B.C. At Tanagra a large series of graves was opened by the Greek authorities in 1911, but the finds, though numerous, were poor. There were more than a hundred terra-cotta statuettes, but none of fine quality.

**Thessaly and Macedonia.**—Thessaly has been consistently studied by Arbanitopoulos in his capacity as Ephor of Antiquities and as a soldier in the Balkan wars (1912-3). The new territory here and in Macedonia was surveyed as soon as acquired, and a central museum for Thessaly was established in the former Turkish custom-house at Ellassona before the cessation of hostilities. The sites of Pella and Dion were examined by the Greeks, and the French began to excavate the necropolis and theatre of Philippi in 1914. In the next war, the landing of the Allied forces at Salonica led to some archaeological discoveries in the occupied territory. Reports of the work of British and French troops were published in the *Annual of the British School at Athens* in 1919. The results were scanty, as would be expected during a military campaign. Prehistoric sites were located on the characteristic mounds of the country, and some were superficially excavated; but most finds were accidental and unrecorded, and many were dispersed and lost. The antiquities collected at the headquarters of the British Salonica force were presented to the nation by the Greek Government, and are now in the British Museum. Shortly before the war a double-chamber tomb was excavated in a tumulus at Langaza. This is the best example of the Macedonian tumulus-tombs, which seem all to be of Hellenistic date. One was excavated by the French in the town of Salonica, and another by the British on the Monastir road in 1919. The Langaza tomb had unusually elaborate architectural ornaments and two pairs of doors, one of wood, the other of marble. The doors were removed to the Ottoman Museum at Constantinople. A series of papers dealing with the little-known antiquities of Thrace has been published by G. Seure in the *Revue Archéologique* since 1911.

**South Russia.**—The sites of the colonies in South Russia used to be a copious source of Greek antiquities of all periods, but the supply

has ceased at the present time. From 1911 to 1914 Kerch (Panti-capaion), Old and New Chersonesos, Tanais, Olbia, a town on the Is. of Berezan, and a cemetery on the peninsula of Taman were being excavated. The results were annually reported by A. Pharmakovski in the *Archaeologischer Anzeiger* of the *Jahrbuch* of the German Archaeological Institute. The typical objects from South Russia were jewellery, pottery, terra-cottas, and glass, mostly of florid Greek style. A remarkable glass bowl with coloured reliefs, said to be Alexandrian work, was found at Olbia in 1913. A glass cup with reliefs carved in the blue and white technique of the Portland Vase, representing a pastoral sacrifice, which was sold by auction in Paris in 1912 for 64,000 francs, was said to have come from Heraclea Pontica. The most valuable historical material from the Pontic colonies is archaic Ionian pottery from Berezan. An unusual find was a Scythian royal grave in a tumulus at Solokha, in 1913. The burial was richly furnished with barbaric jewellery, a gold comb, a bow-case and some vases decorated with Graeco-Scythian reliefs. A welcome work on *Scythians and Greeks*, interpreting material which has long lain inaccessible in Russian books and periodicals, was published by E. H. Minns, in 1913.

**Greek Islands.**—Among the Greek islands Corfu has produced the most notable find. At Goritia, the ancient Corycra, in 1911, the Greek Archaeological Society discovered an early archaic temple of Artemis, the excavation of which was continued until 1914 by Doerpfeld at the expense of the former Emperor of Germany. The striking feature of the building is the sculpture of the west pediment, carved in high relief on limestone slabs. The subjects are, between two panthers a central group of a gigantic Medusa with her two diminutive children, Pegasus and Chrysaor, and corner groups of apparently unconnected battle scenes. A large altar stood before the west front. The small Ionic temple at Kardaki in Corfu was reclaimed in 1912. The French have made good progress in their work at Delos, where the town site is now said to be a Hellenistic Pompeii, its houses still preserving their mosaic floors and fresco-painted walls. When Mytilene was recovered by the Greeks it was proposed to establish there a central museum for the Aegean islands, except Thasos, and the removal of antiquities was in progress in 1913. The Italian occupation of Rhodes put an end to the important work of the Carlsberg Expedition, and caused the loss of much of the material which had been collected at Lindos by the Danes, but the valuable finds from the archaic town and cemetery at Vroulia were fortunately recorded by K. F. Kinch before their dispersal, and were published in 1914. Greek efforts to recover the Dodecanese led to the publication of a lavishly illustrated book describing the Hellenic antiquities of Rhodes, for the information of the Peace Conference. The Germans began to excavate the great temple of Hera at Samos in 1910. This was a stone building with outer columns of marble, not in the Doric style, as Vitruvius said. It was begun in the 6th century B.C. and never finished. Considerable work was done in Thasos by the French School in 1910 and later. Five gates of the city wall were cleared. They were decorated with archaic reliefs, some of which were previously known. Other important finds were seven statues of women from a sanctuary of Artemis Polo, a temple and altar of Apollo Lybuis, decorative terra-cottas from an archaic Prytaneion, a cemetery with carved and painted tombstones, and remains of a triumphal arch of Caracalla.

**Asia Minor.**—Political conditions in Asia Minor still prevented up to 1921 the reopening of the great city sites. During the war some show of general work was made by members of the German Archaeological Commission with the Turkish forces, but this came to little more than notes on the preservation or destruction of well-known monuments. The French had lately renewed their arrangements for the excavation of Colophon, but no results had been obtained up to 1921 on the site. Very little was done in 1913-4; the "temple of Apollo Clarius" was found to be an exedra and a propylaea, and an oracular grotto of the god was discovered in the hills. It contained potsherds which are said to range from "Troy I." to the Roman period. A small collection of pottery and implements made by H. A. Ormerod during journeys in Pisidia is a useful addition to the scanty prehistoric material from Asia Minor, and shows that the characteristic fabrics of Troy and Yortan extend across the peninsula to Cyprus. A prehistoric settlement was found on Kilik Tepe at Miletus. The last excavations at Ephesus, Miletus and Pergamon produced (besides inscriptions) little more than architectural remains of Hellenistic and Roman date. A report of the work done at Ephesus by the Austrian Archaeological Institute since 1909 was issued in 1913. The results of the German excavations at Miletus after the same year were published in 1911. The enormous temple at Didyma was cleared and all its columns were found to be standing to the height of several metres. The excavation of Miletus was completed in 1914. At Pergamon the Germans cleared two Hellenistic temples, in one of which a broken statue, identified as a portrait of Attalus II., was found. Another volume was added to the lengthy publication of the work at Pergamon.

The most brilliant results in Asia were obtained by American archaeologists at Sardis. Excavations were begun by the Princeton Syrian Expedition (H. C. Butler and W. H. Buckler) in 1910, and were continued actively for five seasons. The city lay between a mountain (its acropolis) and the river Pactolus, and its site was marked by two great Ionic columns standing deep in earth. The



excavators began by driving a level platform from the river bank towards the acropolis on the line of the two columns. They therefore had to deal with a constantly increasing mass of soil, for the mountain has been washed down to the river in a continuous slope. A hundred metres from the columns they struck the west end of a temple, and found that more of the structure was preserved as the covering of soil became deeper. The temple, which (as inscriptions show) was dedicated to Artemis, had been half-buried by a landslide from the acropolis hill in the historic earthquake of 17 A.D. It is a 4th-century Greek building of rich Ionic style, and was still unfinished at the time of the earthquake, then cleared and partially rebuilt, and finally used as a water reservoir in the Byzantine period. At the west end, to which the two standing columns belong, some of the other shafts are still preserved to the height of 30 feet. Great efforts were made to remove the deep deposit of earth from the surrounding precinct, and the temple now stands in a wide, open space; but on its east front, where the cut face of the slope is 50 ft. high, progress was checked by a solid mass of the hill which had come near to wrecking the building altogether, having finished its slide less than 100 ft. from the portico. This mass had buried a great part of the Lydian and Greek cities, but on a protected slope some undisturbed Lydian strata were found. Here the pottery sequence goes back through sub-Mycenaean wares to simpler geometric and plain black and grey fabrics. These provide means for classifying the rich finds from the cemetery which was excavated on the other bank of the river. The tombs, which are chambers cut in tiers in the hard clay of the hillside, were used with few exceptions for repeated burials, and the ejected offerings had been scattered down the slope. Two tumuli were dug in the necropolis of Bin Tpe without result. Great quantities of jewellery were found in the tombs, the gold work said to resemble the Etruscan. Especially noteworthy are numbers of engraved gems in Graeco-Persian (no doubt Lydian) style. These are all of the highest quality. Many bronze mirrors were found. The local pottery is marked in form by a conical base, in technique by a white slip, like the archaic Greek wares of Asia. Some important sculpture was found, and a large number of inscriptions, the most valuable being two bilingual texts, in Lydian-Aramaic and Lydian-Greek. These have not, however, given the key to the Lydian language, nor do they support the theory that Etruscan was derived from Lydian. Annual reports of the excavations were published in the *American Journal of Archaeology*.

**Africa.**—Next in importance after Sardinia among ancient sites explored in 1910-20 is the Greek city of Cyrene, also opened by American enterprise. An expedition, led by R. Norton, made its way there in 1910, but, owing to organized hostility among the natives, its first progress was slow and difficult. In 1911 H. F. de Cou was murdered by hired Arabs, but work was continued until the end of the first season, and before the second season could begin, the country was seized by Italians. The coming of this nation here as in Rhodes put an end to the work of others, and the American excavation has been continued by the Italian Government on a larger scale and with the protection of a military force. The principal finds, as in the earlier British search by R. Murdoch Smith and E. A. Porcher, are Graeco-Roman statues. About twenty had been found up to 1921, among them Zeus with the archaic Hermes, Alexander as Diocorus, Eros stringing a bow, three groups of the Graces, two satyrs, a headless Aphrodite, and a head of Athena found by the Americans. Most of the sculpture decorated a bath restored by Hadrian. The Aphrodite, which is thought to be the finest piece, was removed to the Museo delle Terme in Rome; the rest are at Bengazi.

Some more pieces of Graeco-Roman sculpture have been recovered by the French from the sunken ship off Mahdia. The finest bronzes which had been found before 1910 were published in *Monuments Piot*, vols. xvii, xviii. Among the new finds are a head of Athena, a large statuette of Hermes, and a dog. Archaeological work in Africa met with little or no interruption during the war, either in French or Italian territory. Prisoners of war have indeed done scientific service as labourers on certain sites. But except at Cyrene, the new material from Africa is Punic or Roman, and not Greek.

**Sicily and Italy.**—In Sicily there has been continuous work on Greek sites at Camarina, Catania, Messina, and Syracuse; the most important results were obtained at Syracuse. There the temple of Athena was excavated by P. Orsi from 1912 to 1917. A pre-Hellenic settlement was found under the temple, marked by incised and painted geometric pottery. This was followed by archaic Greek remains of the early colonists, Asiatic and Protocorinthian pottery, and some carved ivories. Fragments of the temple included a series of terra-cotta architectural ornaments. Among Sicilian discoveries must be counted a remarkable archaic statue of a seated goddess which was in Paris at the outbreak of war, and was soon afterwards acquired by the Berlin Museum.

Researches in South Italy have produced new evidence of the foundation and early relations of the Greek colonies. At Caulonia in 1912 Orsi found prehistoric remains, the Greek city defences, a Doric temple, houses and a cemetery. Here, as elsewhere in Magna Graecia, the architectural terra-cottas are a valuable part of the finds. The sanctuary of Hera Lacinia at Croton was located in 1912. E. Gabrici's extensive researches at Cumae were published in 1913.

A temple of Zeus was excavated on a terrace of the acropolis; the great temple of Apollo crowned the summit of the hill. Here, too, the date of the earliest remains goes back before the Hellenic settlement, to the 11th century B.C. In one of three Greek temples excavated at Locri were tiles inscribed in Greek with the name of Glodius Pulcher. A cemetery at Locri yielded large numbers of poor Greek vases, and some exceptionally fine bronze mirrors.

**Etruria.**—A few mirrors and some Greek vases were found in Etruria at Vignanello in 1913; and from an Etruscan tomb at Todi in 1915 there were obtained some bronzes and more than 70 red-figure vases. The best bronze was a helmet with reliefs on the cheek-pieces; the finest vase an Attic *kylix* signed by Pamphaios. Etruscan antiquities are receiving closer study, but its first results will probably tend more to controversy than to agreement. A paper by F. Weege (in *Jahrbuch*, 1916) on the two most important series of paintings at Corneto argues that these were executed in the archaic style of North Ionia by a Greek artist who had lived among the Etruscans long enough to understand their national life and spirit. To Greeks also we shall perhaps attribute the splendid terra-cotta figures found at Veii in 1916. These had been piously buried near a Roman road. The best preserved is an archaic Apollo, whose arms only are missing. Fragments of other figures indicate that the complete work was a group, not for architectural decoration, representing a contest of Apollo and Heracles about a hind in the presence of Hermes and Artemis. That the archaic art of Etruria was wholly Greek it is hard to believe. It is still equally hard to distinguish Greek work from Etruscan art inspired by Greek models.

**BIBLIOGRAPHY.**—Periodicals:—(American) *American Journal of Archaeology*; *Classical Journal*; (Austrian) *Jahreshefte des Österreichischen Archäologischen Instituts*; (British) *Annals of Archaeology and Anthropology*; *Annual of the British School at Athens*; *Antiquaries Journal*; *Archaeologia*; *Journal of Hellenic Studies*; *Year's Work in Classical Studies*; (French) *Bulletin de Correspondance Hellénique*; *Comptes Rendus de l'Académie des Inscriptions et Belles-Lettres*; *Revue Archéologique*; *Revue des Études Grecques*; (German) *Jahrbuch und Athenische Mitteilungen des Deutschen Archäologischen Instituts*; (Greek) *Ἀρχαιολογικὸν Ἐπετηρίδιον*, *Ἀρχαιολογικὴ Ἐφημερίδα* and *Ἱστορικὸν τὸν Ἀθηναίων Ἀρχαιολογικῶν Σπουδῶν*; (Italian) *Annuario della R. Scuola Archeologica di Atene; Atene e Roma; Ausonia; Bollettino d'Arte; Cronaca di Belle Arti; Monumenti Antichi; Notizie degli Scavi di Antichità and Rendiconti della R. Accademia dei Lincei*. Special Publications, Prehistoric Period:—R. B. Seager, *Explorations in the Island of Mochlos* (1912); R. M. Burrows, *The Discoveries in Crete* (1913); E. H. Hall, *Aegean Archaeology* (1915); *Excavations in Eastern-Crete: Sphoungouras* (1912); *Vrokastro* (1914); R. B. Seager, *The Cemetery of Pachyammos, Crete* (1916); A. J. B. Wace and M. S. Thompson, *Prehistoric Thessaly* (1912); German, Archaeological Institute, *Tiryns*, vols. i, ii (1912); *Classical Period*:—F. H. Marshall, *Discovery in Greek Lands* (1920); Cyrene, *Notiziario Archeologico del Ministero delle Colonie* (1915); *École Française d'Athènes. Exploration Archéologique de Délos* (1911-4); J. Keil, *Ephesos. Führer durch die Kunstdenkmäler* (1915); Austrian Archaeological Institute, *Forschungen in Ephesos* (vol. ii, 1912); Th. Wiegand, *7<sup>tes</sup> Vorläufiger Bericht über Mittel und Didyma* (1911); *Milet* (vol. i, parts iii, iv, v, vol. iii, part i, 1913-9); *Altentümer von Pergamon* (vol. i, parts i-iii, 1912-3); F. Kinkel, *Fouilles de Vrochali, Rhodes* (1914); *Sardinia* (vol. vi, part 1); E. Littmann, *Lydian Inscriptions* (vol. xi); H. W. Bell, *Coins* (1916); E. H. Minns, *Sceythians and Greeks* (1913); Th. Wiegand, *Wissenschaftliche Veröffentlichungen des deutsch-türkischen Denkmalschutz-Kommandos* (1920).

(E. J. F.)

**ARCHITECTURE** (see 2.369).—UNITED KINGDOM.—The years 1910-4 were years of great building activity in England. Money was plentiful and only faint rumblings of the impending storm of labour troubles were heard. Many of the recently incorporated municipalities, whose activities were constantly increasing and were hampered by the inadequacy of the old borough council offices to accommodate their increasing staffs, were desirous of obtaining municipal buildings worthy of their civic dignity. The large commercial firms were meditating building new offices of ever-increasing splendour, and the newly enriched, who have always had the ambition to possess land and become county magnates, were planning palatial residences for their newly acquired estates. The war put a stop to all these activities with a suddenness that could hardly have been contemplated. So many years had elapsed since the last great European war that its effects had been forgotten. In fact, opinions were by no means at one as to the effect of war on the arts generally. On the one hand there is no doubt that in the ancient and mediaeval monarchies and republics the arts flourished vigorously during the stirring times when these states were consolidating their power by conquest, some of their finest works having been erected as records in stone of victories over their enemies and their cities having been embellished with

objects of art taken as spoils from the vanquished. On the other hand it may be argued that a lengthy peace, when man's energies lack the outlet which war provides, may tend to turn those energies in quite other directions and cause an outburst of exuberant originality—too often mistaken for genius—in all the arts that almost inevitably leads to such a decadence as is evidenced in "Dada" poetry, futurist and cubist painting and the bizarre extravagances of the late Baroque style of architecture.

But war as waged by the ancients or in fact down to the end of the 19th century was a very different thing from what it is now. In the early part of last century the opinion was growing that war was in course of being modified, softened and civilized, made—as Leigh Hunt says—a thing of courtesy and consideration. Now, however, "frightfulness" is the predominating idea in war. The perfection of modern engineering skill, the enormously increased calibre and range of modern artillery, the conquest of the air as a medium for rapid transport and a fierce velocity of attack never before dreamed of have resulted in a completeness of material devastation that must be seen to be realized. In France alone during the World War 250,000 buildings, including 1,500 schools, 1,200 churches and 377 public buildings, were destroyed so completely that no restoration was possible; while the enormous cost of modern warfare impoverishes all the combatants to such an extent that the spoils which used to go to the victors and be employed in adorning their cities are non-existent.

These are the direct effects of war on the creative arts of man, and the indirect effects are no less harmful. The dragging away from their ordinary peaceful pursuits of all the workers, and the consequent necessity of restricting the output of everything but what is needed for carrying on the war, puts a stop to all constructive effort of an artistic kind. This restriction continues afterwards partly through the scarcity of materials and partly through the demoralization of labour caused by war.

**War Buildings.**—It seems clear therefore that modern war must have a crippling effect on the arts of peace, especially with regard to architecture. Statistics show that in the first nine months of the year 1914 building plans were submitted for approval to local authorities in England involving an outlay of £12,200,000, whereas in the same period of 1916 the figures were only £5,870,000, out of which as much as £3,000,000 was for temporary workshops and factories for war materials. These buildings, and others of a temporary character for housing the largely increased staff of Government employees—the cost of which in London alone in the year 1916 was £156,000—were practically the only structures which the British Government allowed to be proceeded with during the last three years of the war. In these temporary buildings celerity in construction was the great desideratum, the materials used being of a non-permanent character, such as wood treated with solignum, uradite and asbestos boarding, variety being obtained by breaking the line of frontage and varying the sky line by a judicious alternation of hipped and gabled roofs. In some cases, however, a more elaborate scheme was adopted, involving a carefully planned lay-out and variety in the treatment and grouping of the buildings, which resulted in a picturesque architectural effect. The most important of these special groups of buildings carried out by the Government was at Grtina, where was built the largest explosives factory in the world. Here the factory proper was in two portions separated by an area within which was located the accommodation for the operatives during construction and for the permanent workers. The site chosen for this township—for such it was—providing for about 20,000 inhabitants, was close to the old Grtina Greca village, within easy distance of two railway stations, the new accommodation roads linking up with the main road from Carlisle to Glasgow. The buildings comprised no less than five churches, ten schools, three recreation halls, hospitals, cinemas, and fire stations in addition to the houses. The work was carried out under the general direction of Raymond Unwin, assisted by several other architects, and the whole scheme reflects great credit on all who were associated with it.

A similar but smaller building scheme was carried out during the war at Chestport, where a site of 28 ac. was acquired for the employees of Finch & Co.'s engineering and shipbuilding works. This site offered considerable difficulties in that there was a fall of 88 ft. from one end to the other, but this irregularity has resulted in the creation of a very picturesque village. The houses, which number ten to the acre, are of various sizes planned to meet the requirements of individual families, the walls being constructed of two solid 4-in. blocks of concrete separated by an air cavity of three inches.

Among buildings specially connected with the modern developments of war may be mentioned those for the construction and housing of non-rigid airships. At the commencement of the war Great Britain possessed only six of these buildings, but 61 have been constructed since. Although of no particular architectural interest the large size of these buildings renders them worth a passing notice. Mr. Leamouth states that one of these buildings covers about 8 ac. in area, is 750 ft. long, 130 ft. in height and each bay has a clear roof span of 150 feet.

**Post-war Housing.**—One of the most interesting developments of post-war building on the part of the British Government was in connexion with land settlement for ex-service men provided for by the Land Settlement (Facilities) Act of 1919. Up to 1914 the various county councils had been empowered to raise local loans for the purpose of providing small holdings under the Small Holdings and Allotments Act of 1908. This work was suspended during the war, and after its termination the Ministry of Agriculture purchased estates and conducted extensive building operations all over the country, the settlement at Sutton Bridge in Lincs. being the most important. The work subsequently devolved on the county councils under the supervision of the Ministry. Between Jan. 1919 and the spring of 1921 upwards of 13,500 small holdings have been erected in England and Wales, consisting of a homestead and farm buildings, involving already an expenditure of over £2,000,000. It was hoped eventually to accommodate over 30,000 settlers. Local materials are used in the construction, and these naturally influence their style. There is naturally not much scope for architectural display, but the planning and aspect of the rooms always receive careful attention. The Ministry placed the supervision of this work in the hands of competent architects under Maj. H. P. Maule.

The cessation of building during the war caused a great shortage of houses, and a large number of housing schemes were started under the Housing Act of 1919 (see HOUSING). Garden cities, garden villages and garden suburbs sprang up in all directions. One of the most important features in these new schemes was the limitation of the number of houses to the acre, only twelve being allowed as a rule in urban and eight in rural districts. This is a great improvement on the earlier garden cities, where the close proximity of the houses practically destroyed all privacy. It is impossible however to lay out a site on this lavish scale in urban districts where slum property has been demolished and the occupants have to be housed in tenements. In such cases, with three-storey blocks properly separated from one another, perfect hygienic conditions can be obtained, with ample fresh air and sunlight, if there are 60 separate tenements to the acre. Among the rural housing schemes started after the war may be mentioned that near Woolwich carried out by H.M. Office of Works, the Borough of Croydon housing schemes at Norbury, Woodside and Waddon, the Welwyn Garden City, and the interesting village at Burhill, near Walton on the Thames, for aged men and women workers. This was erected in accordance with the provisions of the will of the late William Whiteley, and comprises a village hall, a church and about 300 cottages. Sir Aston Webb, Sir Ernest George, Sir R. Blomfield and other eminent architects collaborated in the scheme.

The urban tenement schemes comprise those at St. Pancras, which were in course of being carried out in 1921, at Islington and St. Marylebone. The much increased cost of building made it very difficult to carry out these schemes on an economic basis.

**Churches.**—The completion of the interior of Bentley's remarkable Roman Catholic cathedral at Westminster progressed



I.

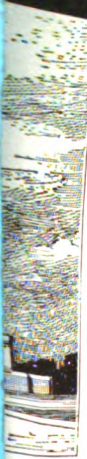

al.  
Feb.





but slowly during 1910-20. Some of the mosaics of the side chapels had been finished by 1921, but very little had been done with the pavements, for which the architect prepared many beautiful designs worked out with the most meticulous detail both of form and colour; if these designs are eventually carried out the marble mosaic floor will not suffer in comparison with the best of the older examples.

The Liverpool cathedral by G. Gilbert Scott, which was much delayed during the war, was making fair progress in 1921, and when completed will be a most interesting example of modern Gothic, and from its commanding position, it will be a striking monumental building as seen from the Mersey. That Gothic still holds its own for ecclesiastical buildings is shown by many modern churches, of which St. Mark's, Walsall, by the late Temple Moore, one of the greatest of the modern Gothicists, and a church at Gretna by Geoffry Lucas, may be taken as types.

**Municipal Buildings.**—Among municipal buildings the enormous London County Hall on the south side of the river was approaching completion in 1921, the Marylebone town hall by Cooper and the offices of the Metropolitan Water Board by Austen Hall had been completed, and the large building for the Port of London offices occupying a commanding site on Tower Hill was well advanced.

**Commercial.**—Among recent commercial buildings one of the most noteworthy is the Cunard building at Liverpool by Willink and Thicknesse. This is one of three important buildings on one of the finest sites in England, with wide spaces all round it, opposite the landing-stage, occupying the position of a small dock that had been reclaimed from the estuary and was closed in the year 1900. The Italian Renaissance style was adopted for this building, the total length of which is 330 ft., and the average breadth 183 ft., the height above the pavement being 120 feet. The building is constructed of reinforced concrete faced with portland stone rock-faced, heavily-rusticated and-battered up to the first-floor level and with dressed portland stone above, the first and second floors forming a *piano nobile*. A very heavy cornice projecting about 7 ft. from the wall face crowns the building and above this is a screen wall about 10 ft. high. It is a matter for regret that there is a lack of harmony in the elevations of the three buildings on this splendid-site. Other large commercial London buildings recently completed in 1921 were the Wolsley Motor Car offices in Piccadilly, by Curtis Green; Australia House in the Strand, by Marshall Mackenzie & Son; and the Kodak building in Kingsway, by Sir John Burnet, which in its unadorned severity is an excellent example of the proper way to treat a skeleton steel structure.

Street architecture in the business centre of a town offers to the architect one of the most difficult problems with which he has to deal. It seems almost impossible to disabuse the mind of the ordinary large retail tradesman of the *idee fixe* that the more space he has for outside show of the articles he deals in, the better it is for his business. The consequence is that in most cases the architect has to start his design on the first floor and to all appearances to carry his structure on a thin plate of glass on the ground floor. This is of course fatal to good architecture. Fortunately the idea has been growing—though very slowly—that a more artistic and alluring display of goods can be made if the various articles are framed in panels separated by bold structural piers of stone. Among the best of recent shop fronts in London treated architecturally from top to bottom may be mentioned the Selfridge building in Oxford Street, and Messrs. Heal's premises in Tottenham Court Road. In these buildings the supports of the superstructure are carried down through the ground floor.

The decade 1910-20 saw the commencement of the passing of the Regent Street which had been familiar to Londoners for over a hundred years. Whatever may be thought of stucco design in imitation of stone, there can be no doubt that Nash achieved a really fine effect in the façades of this street, which were dignified, harmonious and free from monotony, and one cannot repress a feeling of regret to see these old fronts replaced by lofty new buildings which, whatever their individual merits may be,

do not seem likely to group together so as to give the street an effect of architectural congruity.

**Factories.**—The effect of their daily surroundings on the workers in factories has been the subject of careful attention. Anyone who knows the majority of the old mills and factories in the Manchester district, with their tall brick walls and square windows with no attempt to break their hideous uniformity, cannot but be impressed with the horribly depressing effect which these buildings must have upon those who are employed in them. The planning of factories now demands almost as much care as the design for a hospital. Ample light, preferably from the north, is provided and variegated glazed-brick linings are used for the walls of the work-rooms to break their monotony, the junction of the walls and floors being rounded off to avoid dust accumulating. Mess-rooms and changing-rooms are provided and in these are often placed separate lock-up clothes lockers for each female worker. Employers have begun to recognize the fact that expenditure on these refinements is well repaid by a greatly increased output from the employees.

As another example of the way in which the welfare of employees is cared for may be instanced a building recently erected in Gower Street as a hostel for the female employees of a firm of drapers. Included in this building, which contains about 350 bedrooms, are a lounge, reading-room and library and a large hall with stage for concerts and amateur theatrical performances. This marks an interesting new departure in what may be called domestic commercial buildings.

A considerable amount of discussion has taken place as to the desirability of removing the restriction laid down by the London County Council that no building shall be erected of a greater height than 80 ft. from the pavement, exclusive of two storeys in the roof, and allowing sky-scrapers on the lines of those in New York. Granted the existence of an open space of sufficient extent on all sides, there would be no harm in erecting a building 200 or 250 ft. high, but unfortunately where high buildings are most urgently required is in the congested area of the city and here their erection would result in a complete overshadowing of the lower buildings, which would entirely destroy their amenities and practically render them unusable except by artificial light. Any general relaxation of the restrictions is to be deprecated, but in exceptional positions there is no doubt that the rules might be modified with advantage.

**Domestic.**—Domestic architecture, in which England has always excelled, came almost to a standstill during 1910-20, mainly owing to the enormous cost of building. Among recent examples may be mentioned Heath Lodge, Headley Common, by Dawber; a very picturesque house in Avenue Road, St. John's Wood, by Baillie Scott; a house near Goring, a typical example of Ernest Newton's refined work; and a house at Shotton Mill, Surrey, by E. J. May.

**Memorials.**—War memorials are of various kinds; isolated monuments such as crosses and obelisks; shrines or chantry chapels added to a church; mural tablets; and occasionally what may be called a utilitarian building erected as a memorial but only indirectly associated with those whose deaths are memorialized. The number of these erected all over the United Kingdom as well as in France and Belgium is so great that it is impossible to mention more than a few. Among the isolated monuments the first place must be given to Lutyens's Cenotaph in Whitehall, which, for dignity and simplicity combined, cannot easily be surpassed; the all-India memorial at Delhi (*see DELHI*) by the same architect will be one of the most important features of the new capital of India. Sir R. Blomfield has designed a number of memorial crosses, of which it may be said that the bigger the scale on which they are executed the better is their effect. A very graceful example of a memorial cross is one at King's Lynn by O. P. Milne which stands on a large pedestal on the sides of which are engraved in panels the names of those who fell in the war.

The War Memorial Chapel in Ely cathedral by Dawber; the memorial screen and organ designed for Merton College chapel, Oxford, by Sir R. Lorimer, which shows the Gothic tradition still

surviving, the Memorial Gateway at Radley College by Sir T. G. Jackson; the Lifford Memorial Hall at Broadway, the Marlborough College Memorial Hall by Ernest Newton & Sons and the Kitchener Memorial Chapel in St. Paul's cathedral may be instanced as good examples of other types.

Mural tablets do not call for much remark; the chief things to be aimed at in these are good lettering and judicious spacing, many of these tablets being far too crowded. An ornate example of these in cast bronze enriched with precious stones is the Regimental War Memorial to the King's Own Yorkshire Light Infantry in York minster by Voysey.

**Architectural Education.**—A generation ago no systematized scheme of architectural training existed in England. In Paris an Academy of Architecture was established as long ago as 1671, and there can be little doubt that the excellence of the public buildings all over France in the 18th century was largely due to the supervision which that academy exercised over the training of young architects. The foundation of the *École des Beaux Arts* in the beginning of the 19th century carried on the work of the academy, and the institution of the *Grand Prix de Rome*—the blue ribbon of the architectural student, the training for which is spread over from ten to fourteen years and the gaining of which ensured official recognition—offered an incentive to hard work and study which had most beneficial results. In Great Britain until the establishment by the Royal Institute of British Architects in 1837 under Royal Charter of a compulsory examination for all who wished to become members of that body, architectural education was of the most haphazard kind. The new charter empowered the institute to grant certificates and diplomas to those who passed its examinations, and although this policy met with some opposition at first, there can be no doubt that it laid the foundation for systematized architectural education, the full effect of which has only been realized during the last decade. This has been brought about by the increase in the numbers of provincial universities unhampered by old traditions. These bodies, following the lead of similar institutions in the United States, have all recognized the fact that architecture, which is both an art and a science, may fitly be included in the subjects of study for a university degree. In addition to the universities several technical colleges have instituted courses of study in architecture, and there were in 1921 in the United Kingdom ten schools of architecture which were recognized by the Royal Institute and whose certificates exempt those students who gain them from its examinations. These schools are the Architectural Association, London; the universities of London, Liverpool, Sheffield, and Manchester; the Robert Gordon Technical College, Aberdeen; the Technical College, Cardiff; the Heriot Watt College, Edinburgh; and the Glasgow School of Architecture. The university of Cambridge has established a school of architectural studies, but the examination in the subjects comprised in the school curriculum is not associated at present with any diploma. The R.I.B.A., however, exempts certificated students from a certain part of its obligatory examinations.

In Liverpool a special degree in architecture (B. Arch.) has been instituted, but the other universities named include architecture as one of the subjects for an Arts degree. The Liverpool course—which may be taken as a typical one—extends over five years and comprises design in accordance with the methods of the *École des Beaux Arts*; the history of architecture; physics; geology; sanitation and hygiene; building construction and strength of materials as demonstrated in laboratory tests; specifications, etc. Similar courses slightly varying in detail are given at the other schools. In the university of London (University College) a separate professorship of town planning has been instituted. The Architectural Association, London—which was really the pioneer in architectural education in this country—has a very comprehensive course under a complete staff of lecturers, and the studios and class-rooms in its new premises in Bedford Square are admirably equipped.

All these courses enable the young architect to acquire not only facility in design, but also the special technical knowledge now

required in consequence of the development of steel construction, and the fact that so many engineering problems are involved in the erection of any large building; and as all the degree courses involve the passing of a matriculation examination which ensures that the student has first obtained a good general education, one may confidently hope that the reproach so often levelled against architects of a lack of scholarly training is in a fair way of being removed.

**Architectural Research.**—No record of recent architectural developments would be complete without reference to the researches of Mr. Jay Hambidge of New York on the scale of proportion adopted by the Greeks in the design of their most celebrated temples. These must have been designed on some plan, but hitherto all attempts to discover any relation between length and breadth or between the size of the Cella and the whole temple had failed. Mr. Hambidge claims to have established the fact that whereas down to the first quarter of the 6th century B.C. Greek craftsmen used a unit of measurement in which commensurability of line was an essential feature; subsequently a new proportion came into use based on commensurability of area; and this he calls "dynamic" symmetry as opposed to static; in other words geometric and not arithmetic proportion. There is always a danger of a pet theory becoming a sort of Procrustes bed to which facts have to be strained to fit, but Mr. Hambidge has certainly taken great pains to avoid this by having numerous measurements taken independently and checked.

Mr. Hambidge's theory may be described briefly as follows. The diagonal of a right-angled triangle of which one side is unity and the other 2 is  $\sqrt{5}$ , or 2.236.

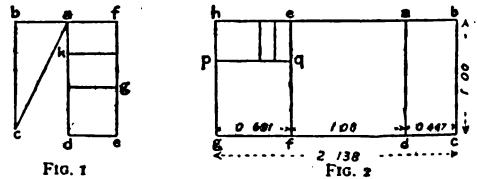

In fig. 1  $ab=1$ , and  $bc=2$ , so that  $ac=\sqrt{5}$ ; if we make  $ad=ac$  and  $af=1$  and complete the rectangle  $adef$ , this will be a  $\sqrt{5}$  rectangle made up of a square  $adg$ , and two rectangles  $gkh$  and  $hkf$ , each of which is  $\sqrt{\frac{5}{2}}=0.618$ . Mr. Hambidge maintains that in the Temple of Apollo at Bassae designed by Ictinus the proportions are based on this rectangle and its multiples and submultiples. In the case of the Parthenon a more elaborate basis is adopted; in fig. 2  $abcd$  is a  $\sqrt{5}$  rectangle and if its long side be taken as unity the short side will be 0.447. If to  $ad$  the long side of this rectangle we apply a square the side of which is 1 we get a rectangle  $adef$  of which one side = 1 and the other 1.447. The reciprocal of this latter figure is  $\frac{1}{1.447}=0.691$ ; and if we apply to  $ef$  a rectangle  $efgh$  the area of which is 0.691 we shall obtain a large rectangle  $hbcg$  the area of which is 2.138, which comprises a rectangle  $abcf$  whose area is 1.447, and a smaller one  $efgh$  of area 0.691. This last rectangle is in all respects similar to  $adef$ , and if  $gh=ef$  then  $efgh$  will be a square and  $hbcg$  a  $\sqrt{5}$  rectangle. Now whatever we may think of this somewhat elaborate basis of measurement it is remarkable in how many cases the ratios connected with the figures 2.138, 1.447 and 0.691 fit within very small fractions actual measurements of the Parthenon, which, as well as the temple at Bassae, was designed by Ictinus. For example the actual breadth over all of the base of the Parthenon according to Penrose is 111.341 ft. and this figure multiplied by 2.1382 gives 238.069 as the length, the actual measurement so far as can now be ascertained being 238.154, a variation of less than one inch.

Mr. Hambidge has applied this theory to Greek statues and vases with—as he claims—the same results. Those who are interested in the subject may be referred to two papers read before the Royal Institute of British Architects on March 30 1920 and March 5 1921.

The prospect for architectural development in the immediate future was not altogether a bright one in 1921. Although many building schemes both in London and the Provinces were ripe for carrying out, they were kept in abeyance owing to the enormous cost of building and uncertainty as to the action of Labour. Also official architecture was spreading. Large Govern-

ment departments, which used to invite competitive designs for their new buildings with excellent results, were increasingly tending to prepare their own designs. This must lead to a stereotyped style and is not in the best interests of architecture or architects. Design—as far as plan is concerned—has undoubtedly improved immensely, but as to the style which will be adopted for future buildings prophecy would be rash. In 1830 Quatremere de Quincy, in the preface to his *Biographies des plus célèbres Architectes*, uses these words: "Comme nous ne reconnaissons de véritable art d'architecture que celui qui . . . a dû son origine, ses progrès, ses principes, ses lois, sa théorie et sa pratique aux Grecs . . . nous devons prétendre qu'on ne trouvera dans notre recueil aucune notion d'aucun ouvrage du genre appelé Gothique." This seems typical of much modern criticism. The author was surrounded by some of the most beautiful examples of mediæval art, but ignored them utterly, and yet 25 years later the Gothic revival was in full swing. In 1900 Penrose said that it was impossible to find any one who took the slightest interest in Greek architecture, yet a few years later Neo-Grec and a bastard sort of classic was all the rage in England, while in America many of the finest new buildings are in the purest classic style. Now a free renaissance is in vogue, but how long it will last and what will be its developments no one can tell. The hope is that the complication of modern requirements and the exigencies of modern construction combined with wider knowledge and closer study of ancient examples may lead to the working-out of the great main principles which underlie all the old styles, so as to adapt them to modern necessities without slavish copying of their forms and features. (J. S.)

## UNITED STATES

The Centennial Exposition in Philadelphia (1876) had revealed to a somewhat self-centered and self-satisfied United States the flagrant grossness of its current architecture; the Chicago World's Fair (1893) less than 20 years later disclosed both the possibilities of architecture and the capacity of a new generation of architects. Its influence was widespread so far as the public was concerned, and gave architects themselves new ideals and greater confidence. From 1890 to 1900 the architectural product of the United States was vast in bulk and high in quality. The American Institute of Architects (founded in 1857) broadened its scope and influence, while schools of architecture associated with universities and technical institutes offered wide opportunities for architectural education. The results were evident in the first decade of the 20th century. The Boston Public Library and the Rhode Island State Capitol of McKim, Mead and White were the forerunners and inspiration of many other structures of similar nature and quality, the New York Public Library of Carrère and Hastings and the Minnesota State Capitol of Cass Gilbert being the most notable. In the same category must be ranked many of the club houses of New York, notably the Union and University, as well as sumptuous residences in the larger cities and summer resorts. The Gothic revival, largely determined by Henry Vaughn and Cram, Goodhue and Ferguson, was meanwhile taking to itself practically the whole field of church building and the larger part of college architecture. Beginning with the Episcopal Church, the adoption of Gothic of some English type (usually Perpendicular) extended throughout the Protestant denominations until within 20 years Presbyterians, Congregationalists and Unitarians were also erecting consistent and magnificent Gothic churches. From the work of Cope and Stewardson at Princeton University the same influence spread through the institutions of higher learning, until Tudor or "Collegiate Gothic," as it is called, usurped almost the whole field, though the "McKim Classic" of Columbia and the revived Colonial of Harvard and many of the smaller colleges and schools still maintained themselves as potent forces and in the latter cases a growing force. The rivalry of Classic and Gothic played little part in the two fields of work where American architecture achieved its most vital and original results, the "sky-scraper" and the private house. Steel and reinforced concrete are, as structural elements in buildings, essentially American. Used at

first as substitutes or hidden devices clothed with traditional architectural forms, they subsequently developed and established what may be called a "steel frame style." Many daring exponents led the way, including Cass Gilbert, who in the Woolworth Building produced a masterpiece. All the great cities (except Boston which prohibits "sky-scrapers") possess many examples of this brilliant and original work, and in New York in particular there is an extraordinary display of towers.

By 1920, however, there were signs that the vogue of 50-storey buildings was passing, and probably would take its place in history as a brief but sensational episode that brought out some of the most daring exploits, and gave play to the most exuberant fancy, in the architectural record. At the opposite pole stood the domestic architecture of the 20th century. Between 1850 and 1880 this had fallen to the lowest depths, and the influence of H. H. Richardson, distorted after his death by incompetent imitators, was deplorable. Fortunately there came a sudden return to the Colonial models of the 18th century, together with a new study of the domestic buildings of England of the 15th and 16th centuries; and though at first the adaptations were crude and unintelligent, the improvement was rapid, and an extraordinary level of excellence was achieved. No one exerted a wider influence in this direction than Charles A. Platt. So vast was the architectural product of the United States during the first 15 years of the century, that it would be impossible to catalogue the examples of the highest excellence. Among the more distinguished public buildings, in addition to those noted, should be included Henry Bacon's masterly Lincoln Memorial in Washington and B. G. Goodhue's revolutionary design for the Nebraska Capitol. In this field, however, politics were apt to enter with disastrous effects, as for example in the Pennsylvania Capitol. In the work of the national Government there was a serious retrogression during 1910-20, and Government architecture was in grave danger of slipping back to the deplorably low level of the 20 years following the Civil War. Where the political element was eliminated, public architecture achieved a high standard, particularly noticeable in art galleries, libraries and museums. Amongst the first were the Buffalo gallery by Green and Wicks, that at Minneapolis by McKim, Mead and White, and that at Boston by Guy Lowell. One of the most admirable of recent libraries was in Indianapolis, the work of Paul Cret and Zant-zinger, Borie and Medary, associate architects, while the Pan-American Building in Washington, by Albert Kelsey and Paul Cret, was an unusual example of vital and personal design. Closely allied were many fine club houses such as the Grand Army Hall in Pittsburgh by Henry Hornbostel, and the Masonic Temple of the Scottish Rite in Washington by John Russell Pope, a building of strikingly noble proportions and majesty of design. In all these buildings classical motives were general, but they were handled with suppleness and originality. Such structures as the Indianapolis library and the Scottish Rite Temple in Washington, D.C., evinced a vital and creative art. Many buildings for universities and colleges, and for schools both public and private, showed equal freedom based on penetrating knowledge of precedents, though the models were almost exclusively English Tudor or American Colonial. Cope and Stewardson initiated the vogue of the former at Princeton, continuing it at Bryn Mawr, Pa., and at Washington University, St. Louis, and it swept over the whole eastern part of the country. Cram, Goodhue and Ferguson took up the line of development in the vast, fortress-like U.S. Military Academy at West Point and continued it at Princeton in the Graduate College, as well as in other educational institutions, north and south. Day and Klauder gave it new force in the Sage dormitories and freshman dining halls at Princeton, in the new buildings at Cornell University, and at Wellesley College, while James Gamble Rogers contributed the most magnificent exposition of the style in the enormous quadrangle nearing completion in 1920 at Yale. Colonial work achieved notable results at Harvard in the shape of new dormitories by Coolidge and Shattuck, but it was more prevalent in the smaller colleges and preparatory schools, as for instance, Williams College and Phillips Academy, Exeter, where the architects worked

along English Georgian lines in the one case, New England Colonial in the other. With the recovery of the delicate proportions and grave simplicity of the early American style, quite distinct in character from contemporary work in England, this style became almost fixed as the standard type for the eastern states, in public and private schools, a result in great measure due to the influence of E. M. Wheelwright. In the Middle West the Tudor motive, popularized by W. B. Ittner in many public schools, held the field; in the south and on the Pacific coast the early style of the Franciscan missions, sometimes touched by Italian influence, was admirably adapted to modern and local conditions by such architects as the Allison of Los Angeles; while in Texas, Rice Institute was being worked out by Cram & Ferguson in a curious style with no particular prototype but epitomizing a dozen Mediterranean impulses, the principal effects being attained by combination of coloured marbles and iridescent tiles.

Church building during the period 1910-20 was exceedingly active. Cathedrals, both Roman-Catholic and Episcopal, some rivalling in size those of France and England, were building in many places. Amongst the former were the great Byzantine cathedral of St. Louis, Barnett, Haynes and Barnett architects, and that in St. Paul by Paul Masqueray. The Episcopal cathedral, still under way in 1921 in Washington, an immense structure in Decorated Gothic, was designed from the plans which were made by the late George F. Bodley of London, and Henry Vaughn. B. G. Goodhue's Baltimore cathedral promised to be an original and vivid adaptation of English Gothic, while the cathedral of St. John the Divine in New York must, when completed, take rank as the third in size of the cathedrals of the world. Begun in 1801 by Heins and La Farge in a modified Romanesque, it was continued by other architects in an adaptation of the French Gothic of the 13th century, though diverging widely from the standard type. The latter architects also built the bishop's palace, deanery and synod house for the same see, as well as the cathedral in Detroit. The parish churches, both Roman Catholic and Episcopal, were many and generally of high order; it is doubtful if anywhere a loftier standard had been attained. Roman Catholic architecture in the United States, until after 1900, was of a debased quality, even worse perhaps than that of the Protestant denominations. By 1920 such work as that of Maginnis and Walsh in St. Catherine's, Somerville, Mass.; the convent of Notre Dame in Boston, and that of the Carmelites in California; and John T. Comes' churches of St. Agnes, Cleveland, St. Mary's, McKeesport, Pa., and St. Monica's, Rochester, N.Y.; also St. Agnes', Pittsburgh, Pa., restored the balance, a result due almost wholly to these architects. An example of Catholic architecture at its best was B. G. Goodhue's Dominican Church of St. Vincent Ferrer in New York. As for the Episcopal church, St. Thomas's and the Church of the Intercession in New York, both designed by Cram, Goodhue & Ferguson, were indicative of the advance made in the 10 years ending with 1920 toward developing a style which should at the same time preserve the best traditions of Christian art and be mobile in its adaptability to modern times and conditions. Apart from the Christian Scientists, who built widely during the same period and usually in a form of Classic closely allied with that of the standard type of Carnegie library, the Protestant trend has been largely towards Gothic of one sort or another. More and more the new work approached the standards, methods and forms of Catholic art, as for example in Allen and Collens's Congregational church in Newton and the Fourth Presbyterian church in Chicago by Cram, Goodhue and Ferguson and Howard Shaw. Occasionally remarkable re-creations of Colonial work were achieved, chiefly for Congregationalists and Unitarians. The Baptists, Methodists and Lutherans showed only sporadically an inclination towards higher standards, and in the south and south-west decidedly inferior structures were still produced. The Swedenborgians always stood for high architectural ideals and were well served during his lifetime by Prof. Langford Warren. They built at Bryn Athyn, Pa., a "cathedral" which was closely modelled on the lines of the richest type of a large English

parish church of the early 15th century. Here for the first time in America the architects (Cram and Ferguson) undertook to put into practice the old "guild" methods of building of the Middle Ages.

With its vast area, its widely varying climatic conditions, its many racial strains, and its groups of independent traditions, the United States has produced as varied an assortment of domestic architecture as might have been expected. Some of the notable palaces of New York and the fine villas set in beautiful gardens and parks in attractive country areas rival the most splendid examples of the Italian, French or English Renaissance, not only in their architecture but in their priceless collections of art of every kind. It is in the more modest dwellings of those not in the multi-millionaire class that recent architecture has scored its greatest triumph. American architects have always been adepts at planning, and American inventors ingenious in devising, new conveniences and luxuries of domestic life. Now that the standard of style has been established and steadily maintained, it may be claimed that the American dwelling equals if it does not surpass all its competitors. The most notable schools of this period were those of Philadelphia, the Middle West, New England and the Pacific coast. The first was initiated by Wilson Ayre, Frank Miles Day and Cope and Stewardson, of whom only the first was alive and working in 1920. But they were followed by a large group of younger men, and the results were striking in originality, consistency and taste. With the local Colonial style as a basis, something was added from the best modern English revival of Tudor architecture, something from the subtle Georgian of Mr. Platt, something from the Italianesque of Mr. McKim, though the dominant note still remained essentially Pennsylvanian. Colour, detail, texture all played their part in a romantic yet honest expression of domesticity, and so universal was its acceptance that even the speculative builder employed the best exponents of this style to develop whole communities along consistent lines. It would be impossible to name all the men who created this significant expression of the best in modern American domestic architecture, but Robert McGoodwin, together with Mellor, Meigs and Howe, Willing and Sims, Edward Gilchrist, and Duhring, Okie and Ziegler, may be mentioned. In the Middle West, there were two tendencies, one with a mathematical basis, the other almost purely poetic. The first seems to have been started by Louis Sullivan, with his strange and vivid motifs in geometrical decoration. Frank Lloyd Wright continued and developed this along extraordinary lines with an exaggeration of horizontal elements that seem to have grown out of decorative forms rather than from material requirements. Claude Bragdon and Pond & Pond also contributed to this movement. The other tendency in the Middle West was best represented by Howard Shaw, and was marked by pure beauty, both in form and detail, measurably Italian yet adapted to local conditions. The New England school was primarily Colonial, for it was in New England that the greatest quantity of this early type of work had been preserved. Its recovery and reconstruction were initiated by Arthur Little, but as in the case of Philadelphia, many younger architects, such as Bigelow and Wadsworth, continued the process. Generically allied with New England was New York, which had many masters of domestic design, if no clearly defined school. Perhaps the most brilliant work, because the most direct, delicate and intrinsically beautiful, was that of Delano and Aldrich, John Russell Pope, and Trowbridge and Ackerman. The school, or schools, of the Pacific coast were at the same time the most baffling and the most stimulating, for strange influences crept in from across the Pacific, mingling with the Spanish traditions of the southern border and yielding alluring results. During the 10 years ending with 1920 the coasts and mountain valleys of southern California blossomed into Persian, Italian and Spanish gardens set with architecture that is so pictorial as to be almost sensational in its appeal, yet with few exceptions it is natural and even naive. The foundations were laid by Willis Polk, Myron Hunt, Elmer Gray and John Galen Howard, but to them have been added many of a younger generation, especially the Allison, Robert David Farquhar and Bernard R. Maybeck.

Commercial architecture, hotels, shops, railway stations, financial and office buildings, remain to be considered. In view of the vast expansion of American wealth between 1905 and 1920, commercial architecture was of importance, and the standard was of the highest. During this period, thanks to such men as Warren and Wetmore, York and Sawyer, Trowbridge and Livingston, Donn Barber, Robert D. Kohn, John Russell Pope, Starrett and Van Vleck, and to many others, hotels became exhibitions of architectural refinement and good taste, however sumptuous; railway stations became imposing and august monuments (witness the magnificent Grand Central by Warren and Wetmore and the Pennsylvania by McKim, Mead and White, both in New York), while an endless number of shop-fronts and office buildings were delicate and scholarly essays in pure design. Individualism, rampant and uncurbed, largely on the part of the many owners, prevented any approach to unity and consistency in street frontages, but taken each by itself the shop-fronts of Fifth Avenue, in New York, for example, formed an epitome of the best (as well as the earlier worst) to be found in the architecture of America.

The conclusion that must be drawn from a survey of architecture in the United States during the 20th century is that the great regeneration initiated during the eighties of the 19th century went steadily forward until architecture became almost of vital interest to a general public that demanded the best that the profession could give. American architects had an advantage over European in the large demand for their services. Good architecture became the fashion, and this was due largely to three factors: the influence of the American Institute of Architects, the training of the Ecole des Beaux Arts, and the dozen or more great schools of architecture in different parts of the country. Behind this, however, lay the fact that apparently American architects as a whole were drawn from the class that possessed the finest traditions and the soundest standards, and that they were able by sheer force of character and excellence of attainment to impose on the public their own ideals and their own standards of value. The World War was an interlude of non-production, but not, apparently, of non-development, and by 1920 a recovery was being effected, while there was evidently an unending supply of younger practitioners to carry on the movement that had already achieved such notable results. (R. A. C.)

**ARCTIC REGIONS** (see 21.938).—The discovery of the North Pole by Peary in 1909 put a check on sensational endeavours, and turned exploration of the Arctic regions along more strictly scientific lines.

**Greenland.**—The exploration of Greenland has been continued, with few exceptions, by Danes who, besides throwing much light on problems in physical geography and Eskimo ethnography, have practically completed the map of the coasts.

In 1910 Knud Rasmussen founded the station of Thule in North Star Bay, Wolstenholme Sound, as a trading station and a base for researches. On April 6 1912, accompanied by P. Freuchen and two Eskimo, he set out with dog sledges from Ingfield Gulf to cross the inland ice in search of E. Mikkelsen, from whom nothing had been heard for three years. Rasmussen reached the head of Danmark Fjord on May 9, travelled down the fjord and up Independence Fjord to Navy Cliff, which he left on Aug. 8 to return across the inland ice. The greatest alt. in the march across the interior was 7,300 ft. This expedition confirmed by cartographical evidence the non-existence of Peary Channel, a fact established by M. Erichsen in 1907 but not known until his records were brought home in 1912. In order to recover M. Erichsen's lost diaries a small expedition in the sloop "Alabama" went to East Greenland in 1909. After wintering at Shannon I., E. Mikkelsen, the leader, and I. Iversen made a journey of 1,400 m., which in length and difficulty was one of the most remarkable Arctic journeys on record. Their course was over the inland ice to Danmark Fjord, where Erichsen's records were found. These included his discovery that Peary Channel does not exist and Mikkelsen therefore had to abandon his plan of returning via the W. coast. After mapping Danmark Fjord he and Iversen returned S. by North-East Cape and the coast, eventually reaching their base, where they had to wait nearly two years for a ship to take them home. In 1912 a Swiss expedition under Dr. A. de Quervain made a successful journey across the southern part of the ice-cap, travelling with the help of dog sledges from Torssukatak Fjord on Disco Bay to Angmagsalik in about 30 days. Their greatest alt. was 8,364 ft.

In 1913 another traverse was made through the heart of Greenland by Capt. J. P. de Koch, Dr. A. Wegener and a Danish seaman. After a winter on the E. coast near Danmark Harbour, during which they mapped Louise Land, they left their base on April 20 with ponies to draw their sledges, and reached Lakse Fjord near Provoa on Aug. 1. The greatest alt. on the crossing was 9,500 ft.

The second Thule expedition was led by K. Rasmussen in 1916 for the exploration of the N.W. coast of Greenland. Rasmussen was accompanied by Lauge Koch, Dr. Thorild Wulff, H. Olsen and several Eskimo. After an arduous journey of over 700 m. across the ice-cap from Thule, work was started in the Long Fjord, where they linked up with previous work of Peary. On the return journey Dr. Wulff and Olsen succumbed to the privation of scanty food and bad weather, and the survivors had difficulty in reaching Etah. This expedition found that Nordenskiöld Inlet, the supposed western end of Peary Channel, is only 14 m. long. The inland ice in the N.W. of Greenland was found to extend nearly to the coast; consequently the hunting grounds are poor and there are few traces of Eskimo migration. Rasmussen considered it very doubtful if Eskimo ever succeeded in reaching the E. coast via the N. of Greenland.

A third Thule expedition started in 1920 under the leadership of Lauge Koch, who proposed to explore the interior of Peary Land and to fill in certain gaps in the chart of the N.W. coast of Greenland. The expedition established its headquarters in Ingfield Gulf, and it was expected to stay in the field until 1922.

The American Crocker Land expedition, from its base at Etah, surveyed part of the coast between Etah and Hall Basin in 1914-5 and made an hydrographic survey of Foulke Fjord. Its principal work, however, was in Ellesmere Land.

**The American Crocker Land Expedition.**—This expedition was sent in 1913 by the American Geographical Society and other bodies in the United States to search for Crocker Land, which had been reported by Peary in 1906 as lying to the W. of Grant Land.

D. B. MacMillan, the leader, had with him W. E. Ekblaw and M. C. Tanquary, naturalists, and Lt. F. Green, cartographer. Failing to reach either Pim I. or Flager Bay in Ellesmere Land, winter quarters were established at Etah, where a meteorological station was maintained throughout the duration of the expedition. In March 1914 MacMillan and Green crossed Smith Sound on the ice, traversed Ellesmere Land, and, passing by Bay Fjord and Nansen Sound, reached Cape Thomas Hubbard. Thence a journey N.W. over rough sea ice for 150 m. failed to reveal any trace of land, and the party returned to Etah by the same route. The farthest point reached was lat. 82° 0' N., long. 108° 22' 30" W. The members of this expedition made several other long journeys. In 1916 Ekblaw crossed Ellesmere Land from Cape Sabine to Bay Fjord and, passing by Nansen Sound, Greely Fjord and Lake Hazen, reached Fort Conger, Greely's former station on Robeson Channel. He returned to Etah across Kennedy Channel and along the shores of Kane Basin. The same year MacMillan made a long journey to Amund Ringnes I. and Christian I. In 1917 a detailed survey was made of the coast of Ellesmere Land from Cape Sabine to Clarence Head, which considerably altered the charts based on the rough surveys of Ingfield, Kane and Hayes. Several expeditions were sent to relieve the explorers at Etah. The first in 1915 met with an accident, and had to winter in North Star Bay; the second in 1916 failed to get through Melville Bay, but the third in 1917 brought back safely those members of the expedition who had not previously returned via the Danish settlements in Greenland.

**Beaufort Sea.**—Much exploration has been done in and around the Beaufort Sea, although the greater part of that sea is still a blank on our maps.

The ambitious Anglo-American Arctic expedition of 1906-7 achieved relatively little real polar work except a journey from March to May 1907 by E. de K. Leflingwell, E. Mikkelsen, and S. Storkensen on the coast in long. 149° W. across the sea ice to lat. 72° 03' N., long. 149° 44' W. where they got a sounding of no bottom in 620 fathoms. V. Stefansson, who was nominally a member of the expedition, spent his time with the Eskimo in the Mackenzie delta, learning their habits and language in order to equip himself for future explorations. During 1908-12 W. Stefansson and R. M. Anderson were studying the Eskimo in and around Victoria I., where they discovered the so-called blonde Eskimo, who had never previously encountered white men. Stefansson's successful explorations must be attributed largely to his methods. He lived in Eskimo fashion using only Eskimo diet, which enabled him to travel light and avoid the necessity of falling back on a base for supplies. Similar methods have been employed with equal success by Rasmussen and other Danes in Greenland.

In July 1913 Stefansson sailed from Nome with a large expedition, supported by the Canadian Government, for the exploration of the Beaufort Sea and the N.W. shores of Arctic Canada. Capt. R. A. Bartlett was in command of the chief ship, the "Karluk,"



and the scientific staff included J. Murray, R. M. Anderson and F. Johansen, naturalists; G. S. Malloch, B. Mamen, and J. J. O'Neill, geologists; H. Beuchat and D. Jenness, anthropologists; W. McKinley and B. M. McConnell, meteorologists; and Dr. Forbes Mackay, surgeon. The "Karuk," with most of the northern party on board, was caught in the ice m. N.E. of Flaxman I. on Aug. 12. The vessel drifted W. until, Sept. 20, when Stefansson and several men were ashore hunting; it broke away during a heavy gale, drifted with the pack until it was crushed, and sank in lat. 72° 8' N., long. 173° 50' W., 60 m. N.E. of Herald I., on Jan. 11 1914. All hands and ample stores were got safely on to the ice. After the loss of a reconnoitring party sent south, Bartlett decided to await the return of daylight before making a move, but Murray, Forbes Mackay, Beuchat and a sailor, eager to attempt the journey, set off for the land, with Bartlett's permission but contrary to his advice. They were seen some days later and never heard of again. On March 12 the survivors landed on Wrangell I. and a week later Bartlett, accompanied by an Eskimo and his crew and seven dogs, set out for the mainland, 160 m. across the ice, to seek help. He reached the shores of Siberia in 17 days, and travelling along the coast via Cape North, reached Emma Harbour, whence he crossed in a whaler to St. Michael. The "King and Wing" rescued the survivors on Wrangell I., and the "Bear" brought them to Nome. Malloch, Mamen and another man had died on the island. The remainder of the expedition, employing several small sloops, did a great deal of useful work. Stefansson, with two companions and a dog team, left Martin Point, Alaska, on March 22 1914, reached lat. 73° N., long. 140° W., and then turned E. to Banks I., landing near Cape Prince Alfred on June 26 and joining his vessel at Cape Kellett. In Feb. 1915 with three companions, Stefansson reached Prince Patrick I., and completed the charting of the coasts. Pushing on he discovered a new island in Gustav Adolf Sea. In 1916 he reached this island, and discovered a second smaller island N. of Ellef Ringnes I. and a third, also small, E. of the first and N. of Melville Island. Ellef Ringnes I. was found to be two islands, and Christian I. was found to be much smaller than had been supposed. Much survey work was also done in Banks I., Victoria I. and the coasts of Dolphin and Union Straits. In 1918 a severe attack of fever compelled Stefansson to hand over the command for the last season's work to S. Storkersen. Storkersen, setting out from Cross I. on the coast of Alaska, travelled over the sea ice to lat. 73° 58' N., long. 147° 50' W. and then returned to the mainland. This journey practically removed from the map the doubtful Keenan Land (reported vaguely in the seventies of last century), while soundings taken during the drift of the "Karuk" and other journeys of the expedition show a narrow continental shelf, and reduce the probability of land existing in the western part of the Beaufort Sea. On the other hand a sounding of only 275 fathoms, about 100 m. N.W. of Isachsen I., indicates the possible occurrence of land in the eastern part of that sea, although Crocker Land has turned out to be a myth. Stefansson's expedition also brought back many observations in anthropology and geology.

**Russian Expeditions.**—Several ambitious but ill-equipped Russian expeditions sailed for Arctic regions in 1912, but came to grief and accomplished little or nothing. G. L. Sedoff hoped to make Franz Josef Land a base for a march to the Pole. He left Archangel in the "Phoca" and wintered at the Pankratiev Is. in the N. of Novaya Zemlya. Next summer the "Phoca" (rechristened the "Suvorin") reached Hooker I., Franz Josef Land. Sedoff set out for the Pole with two companions and 24 dogs. On the death of the leader in the vicinity of Rudolf I. the journey was abandoned. G. L. Brusilov sailed in July 1912 to attempt the north-east passage in the "Santa Anna". The vessel was beset in the ice in the Kara Sea in lat. 71° N. and drifted a year and a half to the vicinity of Franz Josef Land. Eleven men left the ship in April 1914 in lat. 83° N., long. 63° E. Two of these reached Cape Flora, where the "Phoca" found them; the others perished on the way. Nothing has since been heard of the ship and the remainder of its crew. V. A. Rusanov in the "Hercules" was last heard of in 1912 in Matochkin Shar on his way to the Kara Sea on a voyage of exploration. The Russian Government in 1914 sent the "Eclipse" under Otto Sverdrup to search for Brusilov and Rusanov. Sverdrup passed through the Kara Sea searching the coast eastward to Taimir Land where he wintered in lat. 74° 45' N., long. 92° E. He was able to be of some service to Vilkitki's expedition wintering about 180 m. to the east, but returned to Archangel in Sept. 1915 without having found any trace of the missing expedition. Russian efforts to explore the N. coast of Asia in ice-breakers were far more successful, but unfortunately there is every likelihood of the detailed observations which were sent to the Ministry of Marine having been lost. The "Taimir" and "Vaigach," which Capt. Sergiev had taken from Petropavlovsk to near Cape Chelyuskin the previous Sept., left Anadir in July 1913 under Comm. B. A. Vilkitki and Comm. P. A. Novopashenoi for an hydrographic survey of the Arctic coast of Siberia. After charting Chaun Bay the vessels separated, the "Vaigach" following the coast westward and the "Taimir" turning N. for the New Siberia Islands. A small new island was discovered E. of this group and named General Vilkitki Island. Bennett I. was found to be much smaller than had been supposed, and no sign of Sannikov Land (reported on more than

one occasion to have been seen from Kotelnoi, New Siberia I.) was discovered on the route to Taimir Land. Here the two vessels met, and continued the coast survey. New land was discovered N.W. of Cape Chelyuskin. Nikolas Land extends from lat. 77° 50' N., long. 99° E., to at least lat. 81° N. It was surveyed on the east, where a landing was made in lat. 80° 04' N. The land rises to 1,500 ft., is heavily glaciated, and in geological structure is similar to the mainland. Between Nikolas Land and the mainland two islands were discovered and named Alexis and Starokadomski, each with a greatest width of about 6 miles. The existence of these lands helps to account for the usual obstruction of pack-ice in the waters of the Nordenskiöld Archipelago and the Kara Sea. The vessels being prevented by ice from going farther westward, returned eastward along the N. of the New Siberia Is. to Koluchin Bay (Sept. 29) and back to Vladivostok. In July 1914 Vilkitki set out again with the same vessels. Ice prevented a search of Wrangell I. for Stefansson's men. A new island was discovered in lat. 76° 10' N., long. 153° E., and surveyed. The vessels passed N. of the New Siberia Is., again seeing no sign of Sannikov Land, and reached Cape Chelyuskin late in August. Some further surveys of Nikolas Land were made, but ice conditions were bad. Attempts to push westward failed, and by the middle of Sept. winter quarters were found about 100 m. W. of Cape Chelyuskin, the "Taimir" in lat. 76° 41' N., long. 100° 50' E. and the "Vaigach" in lat. 76° 54' N., long. 100° 13' E. The vessels got clear of the ice, and proceeded early in Aug. passed through the Kara Sea without encountering ice, and reached Archangel in Sept. 1915.

**Roald Amundsen.**—The long-deferred expedition of Roald Amundsen to the polar basin left Norway in June 1918 in the "Maud," built on an improved model of the "Fram."

The first winter was passed near Cape Chelyuskin. From there two men were sent home with dispatches via Siberia, but have not been heard of again. In Sept. 1919 the "Maud" continued her voyage through the ice-encumbered Nordenskiöld Sea and Laptev Strait. East of the New Siberia Is. Amundsen pushed his vessel into the pack in order to begin his drift across the Arctic Ocean, but on finding that the current was setting S. he abandoned the attempt for the year, and sought winter quarters at Aion I., Chaun Bay. In July 1920 he arrived at Nome in Alaska having completed the north-east passage. Soon after he left for the north to resume his original plan. The "Maud" may be expected to emerge between Greenland and Spitsbergen not later than 1923. The Norwegian Government has arranged for depots of food to be laid on the N. coasts of Greenland and Grant Land. The work was done in 1920 by the Dane, G. Hansen.

See also the article SPITSBERGEN.

**Claims to Sovereignty.**—During the last ten years practically all unclaimed Arctic lands have come under the sovereignty of one or other State. The treaty transferring the Danish West Indies to the United States (1917) contained a clause recognizing Denmark's right to extend her economic and political sphere over the whole of Greenland. Soon after the outbreak of the World War Russia notified a formal claim to the Arctic islands lying N. of Asia. In Aug. 1914 Capt. Islamov hoisted the Russian flag on Franz Josef Land in anticipation of any claim that Austria might sustain by right of discovery. The Supreme Council in 1919 conferred the sovereignty of Spitsbergen and Bear I. on Norway. All the islands of the American Arctic Archipelago are claimed by Canada.

**Bibliography.**—F. Nansen, *In Northern Mists* (1911), throws new light on the early history of Arctic exploration. A bibliography of much use but limited scope is by J. M. Hulth, "Swedish Arctic and Antarctic Explorations," 1758-1910, *K. Svenska Vet. Akad. Årsbok for 1910*. *Les Expéditions polaires depuis 1800: Liste des États-Majors*, by J. Denucé (1911) covers both Arctic and Antarctic. A useful general "Map of the Arctic Regions" with a list of authorities, appeared in *Bull. Amer. Geog. Soc.* 45 (1913). The Danish work in Greenland is recorded mainly in *Meddelelser om Grønland*; in vol. xli. (1913) G. Amtrup, "Report on the Danmark Expedition, 1906-1908"; in vol. li. (1915) E. Mikkelsen, "Report on the Alabama Expedition, 1909-1912"; in vol. li. (1915), K. Rasmussen, "Report on the First Thule Expedition, 1912"; in vol. liii. (1917), H. P. Steensby, "An Anthropogeographical Study of the Origin of the Greenland Eskimo." For other Danish work see K. Rasmussen and others, *Grønland langs polhavet, udforskningen af Grønland fra Nordvesten til Kap Morris Jessup: Skildring af den II. Thule Expedition, 1916-18* (1919), also E. Mikkelsen, *Lost in the Arctic* (1915). Official reports of the Stefansson expedition in *Report of the Dept. of Naval Service*, Ottawa, 1915, 1916, 1917 and 1918; also *Report of the Canadian Arctic Expedition 1913-18* (10 vols. Ottawa, in course of publication); "The Activities of the Canadian Arctic Expedition from 1916-1918," V. Stefansson, *Geog. Rev.* Oct. 1918; V. Stefansson, *My Life with the Eskimo* (1913), and R. A. Bartlett and R. T. Hale, *The Last Voyage of the Karuk* (1916). For Vilkitki's work see translation from Russian in *Geog. Journal* vol. liv. pp. 367-375 (1919) and *Petermanns Mitteilungen*, vol. lx. i, 1914, pp. 197-8. Accounts of the Crocker Land expedition are to be found in the *Geog. Rev.* from 1913 onwards and in *U.S. Naval Inst. Proc.* vol. xliii., 1917, and vol. xliiv., 1918. F. Nansen, "Spitsbergen



Waters." *Videnskabs. Selskabs Skrifter No. 2 (Kristiania 1915)*, contains oceanographical investigations in the Barents and Greenland seas. (R. N. R. B.)

**ARDILAUN, ARTHUR EDWARD GUINNESS**, 1ST BARON (1840-1915), Irish philanthropist and politician, was born at St. Anne's, Clontarf, Nov. 1 1840, the eldest son of Sir Benjamin Lee Guinness, 1st bart., head of the famous brewing firm of Guinness. He was educated at Eton and Trinity College, Dublin, and in 1868 succeeded to the baronetcy on the death of his father. He then became head of the firm of Guinness, but shortly afterwards retired. He entered Parliament in 1874 as Conservative member for the city of Dublin, holding the seat till 1880, when he was raised to the peerage. In 1891 he bought St. Stephen's Green, Dublin, and converted it into a charming park, which he presented to the city. He also bought up various blocks of slum dwellings and converted them into model tenements, with the object of improving the conditions of the poorer classes of Dublin. Lord Ardilaun, who married in 1871 Lady Olivia White, daughter of the 3rd Earl of Bantry, died at Clontarf Jan. 20 1915.

**ARENSKY, ANTON STEPHANOVITCH** (1861-1906), Russian musical composer, was born at Novgorod July 31 1861, and after studying with various teachers finally became a pupil of Rimsky-Korsakov at the conservatoire of St. Petersburg. In 1882 he became a professor at the Moscow conservatoire, and from 1894 to 1907 was director of music in the imperial chapel at St. Petersburg. His works consist largely of chamber music, including the well-known trio, besides several operas, the chief of which are *The Dream on the Volga* (1890); *Raphaël* (1894); and *Nal and Damayanti* (1890). He died at Terioki, Finland, Feb. 25 1906.

**ARGENTINA** (see 2.460).—The pop. of the republic in 1920, according to the calculation made by the Census Bureau, was 8,533,431. The latest census which had then been taken, that of 1914, gave the pop. at that time as 7,885,237, indicating an increase during 1914-9 of 648,194, or 8.2%. The pop. of the political divisions was as follows:—

	1920 Calculation by Census Bureau, Dec. 31 1920	1914 National Census
Federal Capital		
Isla Martin Garcia	1,676,814	1,575,814
Provinces:		
Buenos Aires	2,336,507	2,066,165
Santa Fé	1,007,512	899,640
Entre Rios	475,236	425,373
Corrientes	371,813	347,955
Córdoba	805,940	735,472
San Luis	129,655	116,266
Santiago del Estero	298,119	261,678
Tucumán	350,681	322,933
Mendoza	311,740	277,535
San Juan	131,179	119,252
La Rioja	84,643	79,754
Catamarca	108,544	—
Salta	146,903	140,927
Jujuy	76,506	76,631
Territories:		
Chaco	52,258	46,274
Chubut	28,813	23,065
Formosa	21,880	19,281
La Pampa	124,294	101,338
Los Andes	2,671	2,487
Misiones	62,159	53,563
Nuequen	33,574	28,866
Rio Negro	47,993	42,242
Santa Cruz	11,603	9,948
Tierra del Fuego	2,559	2,504
Total	8,698,516	—

The pop. of the chief cities, according to the latest statistics available, was as follows:—

Buenos Aires	1,668,072
Rosario	222,592
Córdoba	156,000
La Plata	105,000
Tucumán	91,216
Santa Fé	59,574
Mendoza	58,790
Bahia Blanca	44,143

Paraná	36,089
Corrientes	28,681
Salta	28,436

The nationalities most largely represented in the pop., according to the census of 1914, were:—

Argentines	5,527,285
Italians	929,863
Spaniards	829,701
Russians	93,634
Uruguayans	86,428
French	79,491
Turks (mostly Syrians)	64,639
British	27,692
Germans	26,995
Swiss	14,345
Portuguese	14,143

There were also about 15,000 Indians and 500 negroes then in Argentina.

**Agricultural and Mineral Production.**—The total area under cultivation in Argentina was 20,367,082 hectares (50,330,096 ac.) in the season 1910-11 and 24,784,892 hectares (61,218,683 ac.) in the season 1917-8, an increase of 10,889,587 ac., or 21.6%. The area under the principal crops for the season 1917-8 was:—

	Hectares.
Wheat	7,231,000
Lucerne (alfalfa)	6,552,808
Maize (Indian corn)	3,827,000
Oats	1,295,000
Linseed	1,308,600
Barley	244,355
Vines	116,148
Peanuts	26,725
Cotton	11,775
Tobacco	10,725
Sugar-cane	93,310
Potatoes	134,643

The development of cotton-growing in Argentina is especially noticeable, the area under cultivation having increased from 879 hectares in 1895 to 3,300 in 1914 and 11,775 for the 1917-8 crop. The Government has devoted much time and money to its development and has sent young men to the United States to study cotton-growing. Exports of wheat totalled 2,996,408 tons in 1918, maize 664,683 tons, oats 542,097 tons and linseed 391,382 tons, lack of shipping preventing greater exports. These figures may be compared with those for 1908 when 3,636,294 tons of wheat (more than ever before), 1,055,650 tons of linseed (all more than ever before), 1,711,804 tons of maize and 440,041 tons of oats were exported.

Argentina was in 1920 the world's largest exporter of linseed and maize (Indian corn), and third in exports of wheat, being only exceeded in the latter commodity by the United States and Canada. Her crop nearly equalled Canada's for several years preceding 1921. It has been estimated that approximately 80% of the soil of the republic is capable of yielding some form of economic return, but that only about a quarter of such land was in 1920 under any form of cultivation, while practically no part of Argentina is under intensive husbandry. Agricultural education in its various phases greatly progressed in Argentina during the 10 years 1910-20 under the guidance of Dr. José León Suarez in respect of national education and under such local leaders as Dr. Juan B. Teran at Tucumán in the provinces. The inauguration of the university of Tucumán in May 1914 and the development of its instruction in the production of sugar, cotton and other products suited to northern Argentina has been of great benefit to a large section of the country.

In 1917 there were 860 creameries, 470 cheese factories, 27 butter factories and 689 "mixed" establishments, the export of cheese having increased greatly during the World War. There were 408 flour mills, capitalized at \$36,933,659. Most of these were in the provinces of Buenos Aires, Santa Fé and Córdoba. Exports of wheat flour increased from 118,486 tons in 1911 to 176,445 tons in 1918. Argentina produces approximately 350,000 bales annually of wool and there are 14 wool-washing establishments in the country. There were 29 breweries in 1914, and 4,663 establishments for the production of wine in 1917. The wine industry centres in the provinces of Mendoza and San Juan.

The output of all the packing and curing houses in 1914 was \$114,960,886. The petroleum output at Comodoro Rivadavia increased from 14,784 kg. in 1907 to 198,672,698 kg. in 1918.

**Foreign Commerce.**—The imports and exports for the years 1914-8 are shown in the following table:

	Imports.	Exports.
1914 . . . . .	£64,505,992	£ 80,626,303
1915 . . . . .	61,097,601	116,435,855
1916 . . . . .	73,226,114	114,599,904
1917 . . . . .	76,064,235	110,034,009
1918 . . . . .	99,325,943	159,021,120

The amount of trade with each of the five countries with which Argentina does her chief foreign business is shown for the year 1918 in the following table, the amounts being in pounds sterling—

	Imports from—	Exports to—
United Kingdom . . . . .	£24,819,739	£60,690,730
United States . . . . .	33,632,331	32,768,180
France . . . . .	5,149,700	22,430,986
Italy . . . . .	3,969,995	7,992,252
Brazil . . . . .	9,796,341	6,616,380

Although Germany ranked second after Great Britain in imports into Argentina in 1913, her trade sank to practically nothing during the World War; it has since shown signs of increasing. The chief articles imported by Argentina are cottons and woollens, iron and steel, hardware, machinery, railway equipment of all kinds, lumber and coal. The chief exports are agricultural: wheat, maize, linseed, oats, wool, and meats, chiefly beef and mutton. The customs receipts were £19,795,749 in 1913; £12,135,528 in 1914; £9,901,664 in 1915; £10,726,026 in 1916 and £9,800,114 in 1917. The commercial depression which began about the middle of 1920 proved very injurious to Argentine foreign trade, curtailing both imports and exports.

**Finances.**—The expenditure and revenue of Argentina for the years 1915-20 are shown in the following table, the amounts being in pounds sterling:—

	Revenue.	Expenditure.
1915 . . . . .	£34,602,288	£34,572,625
1916 . . . . .	34,602,288	34,572,625
1917 . . . . .	32,962,569	33,973,357
1918 . . . . .	32,860,306	34,409,000
1919 . . . . .	34,969,953	35,671,023
1920 . . . . .	39,255,764	39,245,706

The 1919 and 1920 figures are budget estimates.

**Railways.**—Argentina in 1920 was tenth among the nations of the world and third among American nations in respect of her railway mileage. In 1910 the total was 17,403 m.; in 1915, 21,551 m.; and in 1920, 21,915 m.

**Army and Navy.**—The estimated army budget for 1920 was £3,000,000 and the naval budget £2,004,611. The total peace establishment of the army was in 1920 approximately 1,751 officers and 18,000 men. In addition there was a trained reserve of 300,000 men, 150,000 of whom were of the first line, and 150,000 of the special reserve. A territorial reserve was in process of formation. The navy consisted of two Dreadnoughts, two pre-Dreadnoughts, four armoured cruisers, and one old light cruiser. There were also seven destroyers, being with the Dreadnoughts the only modern units in the Argentine navy. The Dreadnoughts "Moreno" and "Rivadavia" were built in the United States and launched in 1917. Their displacement is 27,040 tons each and their nominal speed 22.5 knots. The personnel of the navy included 316 executive and 97 engineer officers, 23 electrical engineers, and from 5,000 to 6,000 men. There was also a coast artillery corps of 450 men.

The addition of the "Rivadavia" and the "Moreno" to the Argentine navy was by far the most important event in its development since 1910. Since 1914 the German influences in the Argentine army have somewhat abated with the return of the German military instructors to Europe. Both the army and the navy seemed in 1920 to turn more toward British, French and U.S. methods; no less than 23 naval officers were in that year undergoing instruction in the United States.

**History.**—The administration of President José Figueroa Alcorta came to an end Oct. 12 1920, when the inauguration of

Roque Saenz Peña took place. Although early in 1910 an attempt had been made to conduct a campaign on behalf of Guillermo Udaondo, former governor of the province of Buenos Aires, as an opposition candidate to Saenz Peña, this movement did not develop much strength and Saenz Peña was elected without opposition. He was the son of Luis Saenz Peña, who had been President from 1892 to 1895, but was of a more cosmopolitan type, having spent much time in the Argentine diplomatic service, in both Europe and America. Victorino de la Plaza, who had been Minister of Foreign Affairs in the administration of Figueroa Alcorta, now became Vice-President. His long residence in England as Argentina's financial representative had placed him in close touch with sources of foreign investment which mean much to Argentina, and had given him a sympathetic point of view as regards foreign interests and affairs. Saenz Peña's Cabinet was a strong one. Dr. Indalecio Gómez, who had been Argentine minister to Germany, was Minister of the Interior and continued in this office throughout Saenz Peña's administration, while the Ministry of Foreign Affairs was filled by Dr. Ernesto Bosch, who had also been in the diplomatic service. Saenz Peña had no less than four Secretaries of the Treasury, beginning with Dr. José María Rosa, who had put Argentina's finances on a gold basis when Minister of the Treasury in Roca's administration in 1899 and possessed much knowledge of financial affairs. His successors were E. S. Pérez, Norberto Pinciro and Lorenzo Anadón. Dr. Juan M. Garro and Dr. Carlos Ibarguren were Saenz Peña's Ministers of Public Instruction and Worship, Gen. Gregorio Vélez and Rear-Adm. Saenz Valiente holding the War and Navy portfolios throughout the Administration. Esquirol Ramos Mejía, who had been in the Cabinet in the previous Administration, and Carlos Meyer were the Ministers of Public Works, and Adolfo Mujica Minister of Agriculture.

President Roque Saenz Peña died Aug. 9 1914, Vice-President de la Plaza succeeding him. An entirely new Cabinet, except for the Navy portfolio, which continued to be held by Adm. Saenz Valiente, came into office Aug. 9 1914. Manuel Ortiz became Minister of the Interior; José Luis Murature, who had long been an editor of *La Nación*, one of the most prominent Buenos Aires newspapers, Minister of Foreign Affairs and Worship; Manuel Moyana Minister of Public Works; Horacio Calderón Minister of Agriculture; and Gen. Angel P. Allarria Minister of War. The Treasury portfolio was held successively by Dr. Alejandro Carbo and by Dr. E. E. Oliver, and that of Justice and Public Instruction by T. R. Cullen and M. E. Lamas. The period of de la Plaza's presidency almost exactly coincided with the first two years of the World War. When it broke out England stood first in Argentine foreign trade, with Germany a close second. The English also led in the amount of foreign capital invested in Argentina, although French and German investments were also considerable. Through his term of office President de la Plaza maintained an attitude of strict neutrality on behalf of his country, though his personal preference and certain of his official acts showed an inclination toward the Allies.

In 1916, when de la Plaza's successor was to be chosen, divisions in the old Government party, which had been so long in power under various names, made it powerless to prevent the nomination and election of the candidate of the Radical party, Hipólito Irigoyen, who had never before held public office. For the first time in Argentine history the Radical party was in control of the Government and for the aristocrats (from whose ranks almost all the higher officials had been chosen) it substituted as members of the Cabinet either politicians of their own party or practical business men, such as Domingo Salaverry, the able Minister of the Treasury. Although the Ministry of Foreign Affairs and Worship was nominally filled, first by Dr. Carlos A. Becú, who resigned Feb. 3 1917, and then by Honorio Pueyrredón, who had previously been Minister of Agriculture, the able young Under-Secretary, Diego Luis Molinari, who had travelled in the United States and Europe, practically directed the actual management of Argentina's foreign relations during the first five years of Irigoyen's administration. Pueyrredón was not formally made Minister of Foreign Affairs until Sept. 13 1918. The

Interior Department was directed by Dr. Ramón Gómez throughout Irigoyen's term, the Ministry of Justice and Public Instruction by José S. Salinas, and that of Public Works by Pablo Torcello. For the first time in the history of Argentina the Ministry of War was filled by civilians, Dr. Elpidio González (until 1918) and his successor Dr. Julio Moreno. An engineer of some distinction, Federico Álvarez de Toledo, was Minister of Marine until his resignation in 1919, when Julio Moreno was entrusted with the Navy portfolio also. After Pueyrredón left the Ministry of Agriculture in 1917 Alfredo Demarchi, an engineer, assumed charge of that Department. The Vice-President, Dr. Pelagio B. Luna, from the province of La Rioja, who was supposed to represent the Radical influence in the interior of the country, died June 25 1919. Benito Villanueva then became president of the Senate and therefore next in succession to the presidency, although he did not belong to the President's political party. The elections in 1910 strengthened the hold of the President and the Radical party over both Houses of Congress and gave the Radicals reason to hope that they would continue in power and via the 1922 presidential election, in spite of differences of opinion among some of the leaders in the party and the inevitable disputes as to who should be the candidate.

With the entry of the United States into the World War in April 1917, the attitude of Argentina, like that of many other Latin-American countries, became divided. One strong party desired a rupture of relations with Germany, while another believed that Argentina's future position of independence should be safeguarded by a strict neutrality. The general mass of the population was strongly in sympathy with the Allies, with the natural exception of the 26,000 German subjects and the 40,000 others of German origin. Their influence was particularly strong in Argentina because of the excellent German organization there and because of the feebleness of the Allied propaganda until the war was nearly over. For some time after the outbreak of the war in 1914 it had been feared that all the skilled workers and other immigrants of the better class would return to fight for their native lands; and during 1917, 1918 and 1919 44,285 more persons did leave the country as steerage passengers than entered it; at the same time the cost of living rapidly advanced, and there was a corresponding spread of social unrest, partly due to the popular feeling that the President had espoused the cause of labour and so was disposed to listen sympathetically to the claims of the various labour organizations. This attitude brought him into conflict with the English-owned railways, which comprised 74% of the railways of Argentina, and did not discourage the serious strikes of 1917, which were supposed to have been instigated by German agents. The most disastrous of these was the general railway strike which paralyzed traffic throughout the country from Sept. 23 to Oct. 17 1917. Moreover, labour agitations and strikes of all kinds continued to develop in all parts of the country. They distracted public attention from international to local issues.

On Sunday, Sept. 8 1917, the Buenos Aires newspapers published certain cablegrams which had been sent in May and June 1917 by the German Minister at Buenos Aires, Count Luxburg, to the German Foreign Office, in one of which he said: "As regards Argentina's ships, I advise that they be compelled to go back or that they be sunk without leaving any trace (*spurslos versenkt*) or not allowed to pass." Four Argentine merchant vessels, the "Oriana," "Monte Protegido," "Toro" and "Curumalan," were sunk by the Germans. The publication of these cablegrams caused great excitement in Buenos Aires and a few days later, on Sept. 12, Honorio Pueyrredón, the acting Minister of Foreign Affairs, notified Luxburg that he was *persona non grata* to the Argentine Government. Pueyrredón had been personally offended by Luxburg's allusion to him as a "notorious ass" in the published telegrams. On the evening of the same day a large mob destroyed the largest German club in Buenos Aires, attacked the premises of the three pro-German newspapers and seriously damaged a number of German business establishments. Popular indignation was increased by the opera-

tion of a high-powered German radiograph station near Buenos Aires designed to communicate with Nauen, near Berlin. Pamphlets and leaflets were circulated telling of German designs on South America. Intense excitement reigned in the Argentine capital, and on Sept. 19 the Argentine Senate voted by 23 to 1 in favour of breaking diplomatic relations with Germany. On Sept. 24 the Chamber of Deputies voted a like resolution by 53 to 18. A large number of senators and other prominent persons took part in a large and significant pro-Allied parade on Sept. 20. In spite of all this anti-German manifestation, however, the President maintained an attitude of strict neutrality and the German legation continued to function under Count Donhoff as *chargé d'affaires*, while German intrigues in Argentina continued unabated, spreading thence throughout Latin America. But a large number of volunteers joined the Allied armies, and the Argentine communities gave freely to Allied Red Cross.

**Education.**—The following table gives the amounts appropriated for Education in 1910, 1915 and 1920 in U.S. dollars.

	1910	1915	1920
Federal Government . . .	\$15,460,305.60	\$21,043,708.46	\$28,280,897.60
Provinces			
Buenos Aires . . . . .	3,632,227.56	4,464,313.73	6,261,464.92
Santa Fé . . . . .	700,861.00	1,187,712.82	1,173,831.87
Entre Ríos . . . . .	549,469.24	702,537.19	1,074,034.01
Corrientes . . . . .	250,174.78	425,018.42	497,749.36
Córdoba . . . . .	819,207.80	979,844.06	1,300,741.04
San Luis . . . . .	101,851.41	101,851.41	88,430.76
Mendoza . . . . .	335,681.78	335,681.78	450,330.00
San Juan . . . . .	177,025.17	244,670.42	360,009.47
La Rioja . . . . .	101,047.00	105,506.30	97,476.73
Catamarca . . . . .	116,511.30	127,041.00	225,819.29
Santiago del Estero . . . . .	164,911.24	185,000.00	306,118.02
Tucumán . . . . .	414,105.50	710,037.00	775,405.15
Salta . . . . .	236,380.30	251,096.37	213,348.40
Jujuy . . . . .	110,071.94	167,209.00	167,883.79
	\$24,300,123.04	\$31,085,606.15	\$44,303,511.12

(C. L. C.)

**ARGONNE, BATTLES IN THE, 1914-6.** (For the battle of Sept.-Nov. 1918 between American and German forces, see MEUSE-ARGONNE, BATTLE OF.)—On Sept. 14 1914 at early dawn the advanced guards of the French II. Army Corps left St. Menchould with orders to reach Grandpré the same day. The II. Corps was *en flèche*, about half a day's march ahead of the IV Army Corps, which was on its left, and of the left corps of the III. Army on its right. At about 12 o'clock one of the advanced guards of the II. Corps carried, by a forced attack, the village of St. Thomas, a kind of natural fortress dominating the valley of the Biesme. A German staff officer was killed, on whom was found an order of the IV. German Army commanding them to hold the "fortified positions marked by La Justice (2 km. south of Cernay), hills 147 and 148, height 140 (between Servon and the Bois de Cernay), the Mare aux Bœufs, Bagatelle . . ." In the evening of the 14th the French Colonial Corps was stopped by the resistance of the enemy at Ville-sur-Tourbe: the II. Corps carried Servon, but, isolated by the delay of the III. Army and the check to the Colonial Corps, it could not emerge therefrom. It may be said that on the evening of Sept. 14 mobile warfare ceased in the Argonne and trench warfare began.

The German staff had left the valley of the Biesme to take up its positions farther back; this decision seems to have been speedily regretted, for on the morning of the 15th great efforts were made by the Germans to regain the heights dominating the Biesme. The French forces tried at first to continue their northward march, but they soon felt the uselessness of their efforts. Then position warfare was accepted, but so regretfully that immobility was found difficult to observe; time was wasted, and, in war, time is blood. Nevertheless, the return towards the Biesme attempted by the Germans as early as Sept. 15 had not yet been completely successful by July 1918, at which moment the *débâcle* for Germany began. On Sept. 15 1914 the Germans retook Servon, but could not debouch from it. Their efforts to do so remained fruitless during the whole of the war.

Further westwards the II. Corps in vain attempted to reach Binarville. The Germans retook the south edge of that village and gained ground in the woods of La Grurie; but they came up against the most tenacious resistance and were never able to seize Vienne-le-Château, of which they did not leave a stone

standing. More to the east obstinate fighting took place all through the winter of 1914 and the spring of 1915 at Bagatelle, a small ruined hunting-box. Bagatelle fell into the hands of the Germans, but although the latter penetrated into the woods as far as La Harazée, they were unable to cross the Biesme there. The right of the IV. Army was at a spot called St. Hubert, near the Meurissons stream which ends at Le Four de Paris. Le Four de Paris was under the authority of the III. Army, commanded by Gen. Sarraill. The V. Army Corps, left of the III. Army, had not been so rapid in its pursuit as the II. Corps; the liaison of the two armies could, therefore, not take place, as had been planned and was desirable, at the crossing-point of La Viergette on the Haute Chevauchée; the crossing-point was taken by the Germans. On Sept. 23 and 24 the V. Corps, which had succeeded in reaching Montblainville, gave way, lost Varennes and allowed the enemy to approach Meurissons and Le Four de Paris.

On Sept. 29 the XVI. German Corps attacked La Chalade, Le Four de Paris and La Harazée simultaneously, and reached the vicinity of the Biesme. It must be noted that, at that same time, Gen. von Strantz's army forced the Hauts de Meuse, entered St. Mihiel, seized Fort Camp des Romains, crossed the Meuse and endeavoured to advance westwards, beyond Chauvourcut. This meant the envelopment of Verdun, by St. Mihiel and by the Biesme, and was the most critical period of the struggle in Argonne. But on Sept. 30 the German 98th was taken by surprise near La Chalade, two of its battalions being completely destroyed, or nearly so. The Germans were driven back to and beyond St. Hubert. Furious fighting went on at Bois de Bolante, La File Morte, and Courtes-Chanvres. From Oct. 6 the front was practically fixed in these parts.

On Nov. 20 1914 the 10th Div. of the French V. Corps, which was under Gen. Gouraud, became attached to the II. Corps. General Gérard, commanding the II. Corps, then became the real defender of Argonne, while the German facing him was Gen. von Mudra. On Jan. 5 1915 Gen. Gouraud made a successful attack at Courtes-Chanvres.

The Germans had been greatly assisted, at the outset, by a special trench-warfare *matériel* from Metz. On the French side the *matériel* and special mine-warfare units had to be improvised. During the winter of 1914-5 there were no projectiles even for the guns, and those manufactured in haste made the British 75-mm. guns explode.

Shortly after the II. Corps had settled in Argonne the French general-in-chief shifted the limit of the armies. The Aisne now marked the right of the IV. Army, commanded by Gen. de Langle de Cary, and the left of the III. Army, under Gen. Sarraill, whose headquarters were at Ste. Menchould. Ste. Menchould on one side and Varennes on the other were the fountain-head of all orders. Gen. Sarraill in the south, the German Crown Prince in the north, organized the combats that were more often sacrifices. The Aisne in the west, the Oise and the Verdun region in the east, were the limits of that bloody battlefield where the fighting was conducted in the woods, in trenches which were little more than streams, owing to the extreme dampness of the soil. The men were dying from cold and frozen feet; they were so worn out that the slightest wound became mortal.

It would be tedious to enumerate the units, both large and small, that passed through Argonne, won fame and wore themselves out. Nevertheless, mention must be made of the Garibaldi brothers and their legionaries, who, with heroic courage, showed the Germans in a fierce assault that Italian steel is as good as its men.

General Gérard was replaced, on Jan. 15 1915, by Gen. Humbert. The latter was appointed commander of the III. Army, after Gen. Sarraill's reverse, in the month of July 1915.

By the month of Feb. 1916 Verdun had become the centre of the gigantic struggle; Argonne was never quite calm, but the fighting there henceforth took the second place; large numbers of men were no longer sacrificed as at the outset. The armaments balanced little by little and, in Argonne especially, when the Germans had no *matériel* superiority, they no longer dominated in any way.

By a close examination of facts, one may convince oneself that the value of the German armies was due much more to the German war preparations, German material organization for war, than to the value of the soldiers and those in command. Had the Germans been obliged to improvise the defence of Argonne as the French were, they would have been defeated at a very early stage. (V. L. E. C.)

**ARIZONA** (see 2, 544). In 1920 the pop. was 334,162 as against 204,354 in 1910, an increase of 129,808, or 63.5%. This was the largest percentage of increase shown by any state. The pop. of the chief cities was as follows: Tucson, 20,292 (13,193 in 1910), Douglas, 9,916 (6,437 in 1910), Bisbee, 9,205 (9,019 in 1910). The average number of inhabitants to the square mile in 1920 was 2.9 as compared with 1.8 in 1910. The rural pop. constituted 64.8% of the whole in 1920 as against 69% in 1910.

**Agriculture.**—During the decade ending in 1920 agriculture underwent remarkable changes. There was a considerable increase in the number of acres irrigated, from 320,051 ac. in 1909 to 467,349 ac. in 1919, a gain of 46%. Almost a third of this gain was in Yuma county as a result of the Laguna Dam; the greater portion of the remainder was the result of pumping in other counties. The greatest change was the transition from dairy farming to cotton growing. In 1916 the dairy business reached its height, when the dairy cattle in the Salt River Valley were estimated at 60,000. The introduction of long staple cotton reduced this number to about 8,000 at the end of 1920. The development of the cotton industry was notable: in 1914 there were 73,300 ac. under cultivation, and in 1920, according to estimate, 180,000 ac. This increase, coupled with the great rise in the price of cotton, caused cotton land to rise from \$300 and \$400 to \$700 and in some instances to \$1,000 an acre. The great fall in the price of cotton was expected, if it proved permanent, to result in a return to dairy farming and lower land values.

**Minerals.**—In 1910 Arizona's production of 297,250,538 lb. of copper placed her first among the producing states. This increased to 559,235,000 lb. in 1920. The tendency during 1910-20 was toward the development of grade deposits, the Miami Copper Co., the Inspiration Copper Co., the New Cornelia Copper Co., and the Ray Consolidated Copper Co. being conspicuous for this type of work. The older companies such as the Copper Queen, the United Verde, and the Calumet and Arizona copper companies still had high-grade deposits in 1920; but the Copper Queen turned in the direction of low-grade ores, having completed the stripping of Sacramento Hill near Bisbee. The plant for handling this huge low-grade deposit was to be completed in 1921. The yield of gold and silver was not unimportant. Gold production increased from 152,350 oz. in 1910 to 380,034 oz. in 1920; and silver from 2,566,528 oz. in 1910 to 6,098,251 oz. in 1920. Gold production increased mainly because of the output of the Tom Reed and the United Eastern mining companies, the latter producing one-fourth of the total for the state in 1920. Considerable amounts of gold and silver were also obtained in treating copper ore.

**Manufactures.**—The following table shows the growth of manufactures:

	1919	1909
Number of establishments . . . . .	480	311
Proprietors and firm members . . . . .	416	261
Salariéd employes . . . . .	1,403	500
Wage earners, average number . . . . .	8,528	6,441
Capital . . . . .	\$101,486,070	\$32,872,935
Salaries . . . . .	3,111,838	798,141
Wages . . . . .	12,014,769	5,305,183
Cost of materials . . . . .	92,645,437	33,600,240
Value of products . . . . .	120,769,112	50,286,694
Value added by manufacture . . . . .	28,123,675	16,656,454

The principal industries in 1920 were the smelting and refining of copper, cars and general shop construction and repairs by steam railway companies, flour-mill and gristmill products, lumber and timber products.

**Education.**—The progress in public education in the decade 1910-20 was greater than the increase in population. In 1916 a high school of the state was for the first time admitted to the North Central Association of Colleges and Secondary Schools. In 1920 there were in the association 14 of the 29 high schools of the state. The growth of the normal schools at Tempe and Flagstaff kept pace in enrolment and equipment with the growth of the public schools. In 1910 there was organized a state school for the deaf, affiliated with the university of Arizona and under its direction. The university of Arizona increased from an enrolment of 84 regular college students in 1910-11 to one of 892 for the first semester of 1920-1. This institution in 1921 was composed of three colleges and two schools on the campus at Tucson: college of Letters, Arts and Sciences; college of Mines and Engineering; college of Agriculture; school of Law and school of Education. The Agricultural Experiment Station, the Arizona bureau of mines, the state pure food laboratory and the state museum were also on the campus. In 1916 the university of Arizona was

admitted to the North Central Association, and in 1919 it became a member of the Association of American Colleges.

**History.**—During the years 1910-20 Arizona provided two issues of national interest. The first of these was her admission to the Union. As provided by the Enabling Act signed by President Taft June 30 1910, a constitutional convention met at Phoenix from Oct. 10 to Dec. 9 1910 to frame a constitution. The constitution then adopted provided that one-fourth of the electors of a judicial district might, by petition, demand the recall of a judge. If he did not then resign a special election could be held to determine whether he should be recalled. In Aug. 1911 the National House of Representatives by a vote of 214 to 57 passed a joint resolution providing for the admission of Arizona on condition that the constitutional provision for recall be submitted to a vote of the people. President Taft had already informed Congress that he would not sign the bill, and in a message to Congress took the position that he must veto the measure or assume responsibility for the recall of judges. Later in August he approved a resolution granting statehood on condition that the voters in the general fall election strike out the provision for recall. This they did; and on Feb. 14 1912 President Taft signed the proclamation admitting Arizona. After the state was admitted the people amended the constitution, inserting the original clause providing for the recall of judges. The presidential vote in 1912 was 10,324 for Wilson, 6,049 for Roosevelt, and 3,021 for Taft; in 1916, 33,170 for Wilson and 20,524 for Hughes; in 1920, 37,016 for Harding and 29,546 for Cox. Arizona's Alien Labour law provided the other issue of national interest. The voters of the State, 1914, by a majority of 10,684, enacted a law providing that when any corporation, company, partnership, or individual employed more than 5 workers, 80% of these should be qualified electors or native born citizens. The ambassadors of Great Britain and Italy claimed that the law violated existing treaties. The U.S. District Court declared the law unconstitutional as conflicting with the Fourteenth Amendment. On appeal the U.S. Supreme Court upheld this decision, Nov. 1 1915. Justice Hughes in the final decision said that it had already been established that aliens were entitled to equal protection of our laws. The election of Nov. 1916 resulted in a gubernatorial contest that aroused high party feeling. Governor Hunt, supported by a Democratic assembly, had been elected for two terms. He ran for a third time in 1916. On the face of the returns Campbell, the Republican candidate, was elected; but both candidates came to Phoenix in Jan. to be inaugurated, and Hunt refused to leave the executive office. Later he was compelled to surrender the office to Campbell, but assumed it again in Dec. 1917 after the state Supreme Court had declared him the legally elected governor. At the next election in 1918 Campbell was chosen governor, and he was reelected in 1920. The bitter political struggle was largely the outgrowth of an industrial situation that culminated in a number of strikes throughout the state. That at Clifton and Morenci beginning in Sept. 1915 roused the widest interest. This strike, conducted for the most part by Mexican labour, was organized and at first directed by agents of the Western Federation of Miners. The unique characteristic of the struggle was the sympathy for the strikers shown by the chief executive of the state, Governor Hunt having ordered in the early days of the strike that no strike-breaker should be admitted into the district. Another singular characteristic was the absence of the usual violence. This was attributed to the action of the sheriff who deputized strikers themselves to protect the property of the company. There was no loss of life, and although a large concentration plant at Clifton was destroyed by fire, this was not proved to be the work of strikers. After repeated attempts at conference, no settlement was reached till the Western Federation of Miners withdrew, leaving the Arizona State Federation of Labor in charge. An increase of wages was granted; but the managers asserted that this was the natural result of the increased price of copper, and that they had in no way yielded to the strikers. The industrial strife reached even a more crucial stage in the summer of 1917 when the Bisbee deportation incident occurred. The employees in several of the mines had struck for

higher wages and better working conditions; claiming that they had been the losers in the general rise in prices, and that they had not shared in the profits due to the increased value of copper. There was a general fear that violence would result from the activities of the Industrial Workers of the World. Sheriff Wheeler, supported by the conservative citizens of Bisbee, took the position that the members of the I.W.W. and their sympathizers were vagrants, traitors, and disturbers of the peace of the county. In July 1917 the sheriff and his many deputies rounded up over 1,100 of the alleged offenders and deported them to Columbus, N.M. President Wilson at once warned Governor Campbell of the danger of such a precedent; and two months later, at the solicitation of Samuel Gompers, he appointed a committee, of which Secretary Wilson of the Federal Department of Labor was chairman, to investigate and adjust the industrial disputes. This committee found that there was no machinery whereby the grievances could have been adjusted, since the managers refused to recognize certain labour organizations. The committee further recommended that Congress make future deportations a Federal offence. A number of indictments against Wheeler and his deputies were secured; and one case, the State of Arizona v. H. E. Wootton, came to trial. The defendant was freed on the plea of the "law of necessity"; the other cases were not pressed. The last territorial governor was Richard E. Sloan, 1909-11. State governors were George W. P. Hunt (Dem.), 1911-9; Thomas E. Campbell (Rep.), 1919-

**Bibliography.**—*Mining:* Publications of U.S. Geological Survey and Bureau of the Mint (1920). Recall of Judges: *Congressional Record*, vol. xlviii, pt. 4, pp. 3964-3966. *Cases:* Hunt v. Campbell, Pacific Reporter 169; Arizona's Alien Labor Law, 219 Federal; and 239 U.S., Bisbee Deportation; U.S. Labor Department, *Report on Bisbee Deportation* (pub. 1918). *Histories:* McClintock, *Arizona the Youngest State*; Beard, *Contemporary American History*. (H. A. H.)

**ARKANSAS** (see 2.551). In 1920 the pop. was 1,752,204 as against 1,574,449 in 1910, an increase of 177,755, or 11.3%. Of the total pop. in 1920, 1,265,782, or 72.2%, were native whites, 472,220, or 27% negroes, and only 13,975, or 0.8%, foreign-born whites. There were 121,837 illiterates, of whom 79,245 were negroes, 41,411 native whites, and 1,145 foreign-born whites. The pop. was decidedly rural, only 290,497, or less than one-sixth, being classed as urban. The average number of inhabitants per square mile in 1920 was 33.4 as against 30 in 1910. Little Rock was the largest city, with a pop. of 65,142 (45,947 in 1910), of whom 17,477 were negroes. The pop. of the other leading cities was as follows: Fort Smith 28,870 (23,975 in 1910), Pine Bluff 19,280 (15,102 in 1910), and Hot Springs 11,605 (14,434 in 1910).

**Agriculture.**—Agriculture was still the leading industry in 1920 and, in spite of the ravages of the boll-woevil, cotton was the leading crop. In 1916 2,635,000 acres produced 1,134,000 bales, valued at \$111,135,000; and 504,000 tons of seed. The crop of 1919 was considerably less, 869,550 bales, but was valued at \$159,960,400; that of 1920, 1,177,095 bales. Arkansas cotton is of a high quality, the price paid for it being exceeded in America only by that of Florida, California, Arizona and Mississippi. In recent years there has been considerable agitation in favour of diversified farming and this has caused an increase in the production of cereal crops and hay. The corn crop of 1919 (34,226,935 bus.) was valued at \$61,608,482. The development of the rice industry has been very rapid. Introduced in 1904, the production was 2,400,000 bus. in 1910, 6,797,126 in 1919, and 7,780,000 in 1920. The state ranked high in the production of apples, both in quality and quantity. In the production of peaches it ranked next after California, Texas and Georgia and was said to contain the largest of all orchards. The crop was 3,340,823 bus. in 1919. The strawberry crop was valued at over a million dollars a year. The state ranked fourth in the acreage devoted to vineyards. In 1921 plants were erected for the making of grape-juice. In the last few years considerable attention has been given to the introduction of pure-bred live stock. The total value of the farm products in 1919 was estimated at \$341,565,356 as compared with \$175,057,000 in 1916.

**Manufactures.**—In 1909 there were 2,925 manufacturing establishments employing 44,982 workers and turning out products valued at \$74,910,000; the value in 1919 was estimated at \$100,000,000. Lumber was the leading industry, cotton-seed oil the second. Sixty different kinds of trees are cut for the market, hardwood and pine being the most common. The annual cut was about 5,000,000,000 board ft., of which 2,111,200,000 was lumber. The supply of standing

timber was estimated in 1920 at 78,706,000,000 feet. The chief centres of manufacturing were Little Rock, Fort Smith, Pine Bluff, North Little Rock, Helena and Hot Springs. A considerable impetus was given to manufactures, especially in glass, in Fort Smith by the discovery of gas.

**Banks and Finance.**—In 1920 there were 404 state and private bank and trust companies and 76 national banks with capital and reserves amounting to \$29,549,357 and resources amounting to \$273,915,676. The state banks had 389,383 depositors. There were no separate savings banks, but the savings deposits in the banks amounted to \$12,450,710. The increase in the ratio of the banking resources of the state to those of the nation during the years 1909-19 was exceeded only by Oklahoma and Nevada. There were few bank failures for several years and depositors lost little, though there was no guarantee law. The state budget amounted to \$6,516,470. The recognized debt amounted to about \$2,000,000 provided for by special tax. Revenue was derived mainly from the general property tax, but a considerable sum was secured from licenses and poll taxes. In 1920 the assessed valuation, real and personal, was \$612,426,000, which is only a small part of the real value. The appropriations for 1921-3 total \$14,241,395, which was well within the estimated revenue. The largest item, apart from the state aid to public schools, was \$2,400,000 for pensions to Confederate veterans.

**Education.**—The school population was in 1920 676,009, of whom 483,172 attended school. For support of the schools the state and districts expended \$7,600,000 annually. The state university is supported by a special tax which in 1912 was one mill per \$1 of assessed valuation. An amendment to the constitution, submitted by initiative, removing the limit on taxes for school purposes, was to be voted on in 1922.

**Transportation.**—In 1910 the state had 4,876 m. of steam railway; in 1920, 55,220 m. There were in 1920 eight electric street and inter-urban lines with 152 m. of track. In the same year 59,058 motor-cars, trucks and tractors were licensed. By the close of 1920 the road-building programme comprised 9,000 m. at an estimated cost of \$108,000,000, about half of which was under construction or contract. Dissatisfaction, partly over the cost and partly over the fact that only real estate was assessed to pay for these roads, led to the abandonment of many of those projected. Some of the roads were to be asphalt or concrete, but the prevailing type was gravel. As the counties were forbidden to issue bonds the work was carried on by improvement districts with state and Federal aid. The total amount of state aid available 1917-21 was \$1,400,000; Federal, \$4,615,210. To secure this aid the work done by the districts had to meet the approval of the state highway department.

**Minerals and Mining.**—The bauxite industry continued to develop, growing from 115,837 long tons in 1900 to 532,000 in 1918. All the other states together produced only 32,000 tons. Platinum was discovered near Batesville in 1920. The output of coal rose from 13,195 tons in 1880 to 1,701,748 tons in 1910 and to 1,994,738 tons in 1913; after this there was a slight falling off. The production of natural gas was small (125,000 ft. from six wells) until 1915, when the first strong well was opened in Crawford county. The output of the wells near Fort Smith was in 1920 about 200,000,000 ft., only one-fifth of which was used. In 1921 a strong well was developed near El Dorado; also, oil was discovered in the same region early in 1921, and by Aug. the production has risen to over a million barrels a month. The state ranks first in the production of wheat-stones, which are made from the famous "Arkansas" and "Ouachita" oilstones. The clay in Saline county is used for making pottery of a very artistic type.

**History.**—The state continued under control of the Democratic party without interruption from 1874 to 1921. Several attempts have been made to amend the conservative constitution, most of which have ended in failure, owing to the requirement of a majority of the total vote to adopt any amendment. An initiative and referendum amendment was adopted in 1910, but a part of it was declared unworkable by the Supreme Court. In 1916 a new initiative and referendum, submitted by petition, was voted down; in 1920 it received a large majority of the vote cast, but not a majority of the total vote. It was again submitted by petition and will be voted on in 1922. In 1912 an amendment submitted under the initiative limited the pay of legislators to a session of 60 days, with half pay for an extra session of 15 days. The previous session had been long and expensive. The Legislature of 1917 called a constitutional convention. When the convention met, the United States had just entered the World War and a strong effort was made to adjourn without doing anything. As a compromise the convention adjourned to July 1918. It then met and submitted a revised edition of the old constitution. This was rejected by the people. Important legislation during the period 1910-20 included abolition of the convict lease system (convicts may now be worked on the roads); provision for a state farm for convicts; reform schools; state-wide prohibition (1915);

inheritance tax; minimum wage; restricting child-labour; compulsory education; and abolition of the "fellow servants" rule. In 1917 women were by statute given the right to vote in primary elections, in 1920, before the adoption of the national woman suffrage amendment, an amendment to the state constitution giving full rights of suffrage and the right to hold office was submitted to the voters, but failed to receive a majority of the total vote. A legislative Act of 1921 gave women the right to hold office. In 1921 Gov. McRae induced the Legislature to make a beginning of reform in the state administration by abolishing a number of offices and commissions. The governors of the state since 1909 have been: George W. Donaghey, 1909-13; Joseph T. Robinson, Jan. 8-March 1913; W. K. Oldham (acting), March 8-23; J. M. Futrell (acting), March 23-Aug. 6; G. W. Hayes, Aug. 6 1913-7; C. H. Brough, 1917-21; J. T. McRae, 1921-.

(D. Y. T.)

**ARMENIA** (see 2.564).—The years between 1914 and 1921 are, perhaps, the most important of any in the modern history of the Armenian people. The bloodless Turkish revolution of 1908, followed by the assembling of a representative Parliament, opened a period in which, for a time, racial animosities seemed to have disappeared from the greater part of the Ottoman Empire. Armenians hailed the change as the end of their troubles, and massacre and oppression became dim memories. They appeared content henceforward to be citizens of a reformed Turkey and anxious to bear their part in all the duties of citizenship. Some, indeed, went so far in their new-formed patriotism as to call themselves Osmanlis, seeking to make a national name of the term hitherto used only by Turkish Moslems—a term embodying in the past the very spirit of Turkish conquest and oppression. Nor was it merely the rank and file of the Armenian people who so readily accepted the prospect of a new Turkey. Leaders of Armenian revolutionary societies—organizations whose purpose was to achieve Armenian independence, the Hunchakists by constitutional means, the Dashnakists by violence—themselves believed that the Young Turk movement deserved well of the Armenian people, and that the revolution should receive Armenian support. We need not enquire too closely into the causes of this sudden confidence. The Young Turks possessed, as yet, little experience in organization; they were deficient in means: they therefore courted leading Armenians and the Armenian secret societies, from which sources, to some extent, experience and financial aid could be obtained. On their part Armenians held that any change which diminished the power of the Sultan 'Abdul Hamid and his creatures was so much to the good; and their leaders felt themselves competent to use the Young Turks for Armenian ends, and to go with them only so far as Armenian interests required. It is, indeed, a singular fact that the Young Turks and the Dashnakists continue to find some degree of usefulness in each other to the present time.

**Cilician Massacres.**—But disillusionment on the part of the Armenian people in general was not long delayed. The first free Ottoman Parliament met on Dec. 27 1908: in April 1909 massacre broke out at Adana, in the rich Cilician plain. After the first outbreak troops of the Young Turk army were hurriedly brought from Salonika, and the affair seemed to have been stamped out by the promptitude of the Government. But after a few days it flared up again, in consequence, it is stated, of Armenians having fired on the soldiery, who thereupon took an active part in the work of killing and burning. From Adana massacre spread to various towns of the vilayet of Adana, and into northern Syria, particularly at Antioch, Kirk Khan, and Mar'ash. Though thousands perished in the towns, a greater number were slaughtered in remote villages and on lonely roads; for it was the time when Armenians from the mountains were on their way to the annual harvesting on the fertile Cilician plain. It is believed that in all not less than 20,000 lost their lives in this unexpected and disastrous outbreak.

**Origins of the Cilician Massacre of 1909.**—The origins of these massacres remain obscure; that some form of official prompting lay behind them, however, cannot be doubted. Not

once but often it has been proved that Turkish authorities find no difficulty in preventing outbreaks of the kind if they choose; that, in fact, massacre is, at bottom, the result of official connivance more or less direct. The Cilician massacres have been charged to 'Abdul Hamid and his satellites, as an effort by him to discredit the government of the Young Turks. They have been charged to the Young Turks, as an effort by them to discredit 'Abdul Hamid, who had been deposed on April 9—just one week before the affair at Adana. Notwithstanding the vehement disavowal of complicity by the Government, and their ostentatious endeavours to compensate sufferers and provide for orphaned Armenians; notwithstanding the Turkish Commission of Inquiry, and the impartial hanging of Moslems and Armenians, time brings the guilt home more and more definitely to Young Turk leaders.

That the Armenians of Cilicia were blameless cannot be maintained. After the first fraternal demonstrations of the revolution they had adopted a manner toward their Moslem fellow citizens provocative and unwise beyond belief. They had indulged in Armenian national processions, displaying the flag of an independent Armenia; had publicly boasted that Cilicia itself was soon to become an independent Armenia; had insulted and beaten Moslems in the streets of Adana. To the fatal influence of these follies were added the economic facts that Armenian land-owners, already in possession of the richest areas of the Cilician plain, were rapidly increasing their holdings; and that the Armenian population prospered and multiplied while the Moslem population declined. The Moslems of Cilicia, indeed, were gloomily brooding over Armenian affronts to their patriotism, and economic Armenian encroachments on their position as the dominant and ruling race. These matters combined formed a mass of highly inflammable material.

*Armenian Political Position.*—As the Young Turk Government consolidated itself, and its control passed finally into the hands of the Subterranean Committee of Union and Progress, so the prospect of Armenians receiving equal treatment within the Empire disappeared. Armenian representation in Parliament was curtailed by means both direct and indirect. The total number of Armenians who might sit in the Chamber was arbitrarily fixed, irrespective of election results. The lists of voters were compiled under conditions that weighed against Armenians obtaining the vote in the proportion to which their numbers entitled them. In common with other Ottoman Christians the place of Armenians in the State became, in effect, that of undesirable aliens.

*Turkish Wars of 1911-3.*—The Italo-Turkish War of 1911-2 passed without changing the Armenian position. Nor did the first Balkan War, 1912-3, greatly affect the race except as to military service. During these wars it seemed, indeed, that massacre did not suit the policy of the Government, the desire being to stand well with the Powers. None therefore took place. In the Balkan War, however, military service fell heavily upon the Armenian subjects of the Empire for the first time. They were not permitted to serve forming Armenian units, but were distributed throughout the army; and the most laborious and dangerous duties are said to have been assigned them as a matter of policy. In these circumstances desertions were numerous, as might have been expected. But with none of the incentives usually prompting the soldier to high performance, with everything, indeed, against them, the Armenian elements, as a whole, earned the commendation of Nazim Pasha, the Turkish commander-in-chief, who declared in one of his dis-

patches that the Armenian soldiers had performed their duty loyally and with courage.

Attempts by the Powers to ameliorate the political situation of the Armenian people were continued after the close of the Balkan War. Agreement with the Turkish Government seemed promising at the beginning of 1914, on the basis of an increased number of Armenian deputies for the Ottoman Parliament, and for the supervision of Ottoman officials in the "Six Vilayets" of Eastern Turkey-in-Asia by two European inspectors general to be selected by the Powers. There was also to be equal representation of Moslems and Christians on the councils of the vilayets of Van and Bitlis, in which districts the Armenian population was presumed to equal the Moslem. But the proposed reforms came to nothing. The Young Turk Government already had prevision of great events to come, and were temporizing in anticipation of developments.

*The World War.*—Between Oct. 29 and Nov. 5 1914, the action of the Young Turk Government resulted in war being declared on Turkey by Great Britain, Russia, France and Serbia. In committing their country to support of the Germanic Powers the Young Turk leaders saw, as they thought, the great occasion for recovering lost Turkish provinces and reestablishing the Ottoman Empire on the widest foundations, with corresponding advantage to themselves. They believed that with Germanic support they were speculating in certainties. They resolved to use the fortunate opportunity thus presenting itself for making an end of Ottoman internal difficulties as they saw them. Chief among these was the question of the Christian people, of Asia Minor, the Ottoman Greeks and the Armenians, who cherished national aspirations incompatible with Ottoman sovereignty. The "Turkification" of the whole population of Asia Minor—the creation of a single homogeneous race for this great area—was the underlying purpose.

*Policy of Massacre and Deportation.*—How the policy for dealing with the Armenian part of the question took form we do not know. Probably Tal'at Pasha and Enver Pasha had as much to do with it as any—Tal'at at least is credited with its application—but they only sought to follow, on a greater scale, the example set in past years by 'Abdul Hamid. A preposterous and cynical scheme of compulsory colonization as part of the policy has been attributed to German theorists; but it was not even a mask except as affording greater opportunities for destroying the Armenian population. Described in a few words the policy was that of deportation coupled with extermination. The Armenian race was to be uprooted from the wide territories of Asia Minor beyond hope of continuance or return. From convenient areas those of the people able to march were to be deported to Mesopotamia and eastern Syria. Being an industrious and prolific race they might, in Mesopotamia, at least, do something toward creating a profitable, taxpaying province in place of one requiring incessant Ottoman outlay. Armenians from provinces too distant for deportation to be practicable were to be exterminated or driven to a fugitive existence.

*Statistics of Armenian Population.*—The following figures show the numbers and distribution of the Armenian race in Trans-Caucasia and Asia Minor, the destruction of which, or at least of the portion contained in Ottoman territory, was to be encompassed. In Russian Armenia the figures are those of the Russian census of 1916. For the Turkish vilayets they are, in the absence of any authoritative and reliable statistics, an exhaustive and impartial estimate for the period immediately before the war:—

*Districts forming the Armenian Republic of Eriwan.*—Armenians, 795,000; Moslems, 575,000; other elements, 140,000; total, 1,510,000. Areas claimed by Eriwan, but claimed also by Georgia or Azerbaidjan:—Armenians, 410,000; Moslems, 460,000; other elements, 36,000; total, 906,000.

The six Armenian Vilayets of Asia Minor in 1914.

	Bitlis.	Diarbekr.	Erserrum.	Mamul el Aziz.	Sivas.	Van.	Totals.
Armenians . . . . .	185,000	82,000	205,000	130,000	200,000	190,000	992,000
Moslems . . . . .	261,000	400,000	540,000	480,000	977,000	260,000	2,918,000
Other elements . . . . .	19,000	78,000	15,000	2,000	108,000	133,000	355,000
Totals . . . . .	465,000	560,000	760,000	612,000	1,285,000	583,000	4,265,000



*The Policy in Execution.*—It is unnecessary to follow in detail the execution of the infamous policy for the destruction of the Armenian population of Asia Minor. Suffice to say it was begun soon after the outbreak of war by concocting reports of Armenian revolutionary plots in support of the Allied Powers; and then, as far as possible, by a general disarmament of Ottoman Armenians. Though British operations in Gallipoli and Mesopotamia, and Russian operations against the eastern vilayets, kept the Turks occupied in a military sense, they did not prevent Turkish activity against Armenians. During the spring and summer of 1915, indeed, when the fate of Constantinople and Turkey hung in the balance and inhabitants of the Imperial City daily scanned the Sea of Marmora for signs of an approaching British fleet, the Young Turk Government prosecuted their Armenian policy with the utmost rigour. But when the Gallipoli operations had plainly failed, and the outcome of the war was thought to be no longer in doubt, a Turkish defeat in Russian Armenia, attributed by Enver Pasha to the Armenians, was revenged upon the race by massacres of even greater ferocity. From first to last they were organized and carried out systematically. Massacres on the largest scale took place at Bitlis, Mush, Sivas, Kharpuz, Trebizond—wherever, in fact, a considerable and more or less defenceless Armenian population existed. The people were butchered in masses, butchered in groups, drowned in the Black Sea and in rivers, burnt in buildings—killed by whatever processes were found most ready and convenient. Girls were placed in Turkish harems. It should not be supposed, however, that no resistance was offered, that the Armenian people sold their lives cheaply. Although supposed to have been disarmed, weapons remained, and on numberless occasions, in untold villages and towns, a hopeless resistance inflicted severe losses on the attackers.

Deportation, too, became an easy indirect means of destroying Armenian life. On the long routes of eastern Asia Minor by which movement took place; on the subsidiary roads leading to these routes; at the great concentration centres on which the columns of suffering humanity were directed, the Armenian people died of hunger, exhaustion, exposure, disease, in tens of thousands, perhaps in hundreds of thousands. Only a comparatively small proportion of those who set out reached the destination assigned them. The policy of transferring an Armenian population to Mesopotamia and Syria became in execution a wholesale means for destroying those who were despatched.

*Estimated Loss of Armenian Life.*—The Armenian policy of the Young Turks failed, however, in that part of Turkey-in-Asia lying between Erzerum and Bitlis and the Russian frontier. In this region, where the Armenian inhabitants were comparatively numerous, they were able to pass into Trans-Caucasia, or were preserved by the advance of the Russian armies. Within the stricken areas of Asia Minor, too, many escaped—many more than are generally supposed. Kurdish tribes gave friendly shelter; even Turks were not without compassion; the nature of the country, itself, afforded opportunities for escape and concealment on a large scale. And in the Anti-Taurus mountains were Armenian fastnesses unreachd by Turkish forces.

Armenian estimates of the losses suffered by their people as the result of the Young Turk measures are liable to be excessive. It is in the nature of things that they should be. But if we place the loss of life directly and indirectly caused by massacre and deportation since the year 1914, as being in the neighbourhood of three-quarters of a million we cannot be very far from the truth. In addition are what may be called the legitimate losses of war, and these, in proportion to the manhood of the Armenian race, were enormous.

As regards the Armenian population, not only of Asia Minor, but of Trans-Caucasia as well, from first to last Russia is believed to have sent 160,000 Armenian troops from Trans-Caucasia to her battle-fronts in Europe, of whom less than 30,000 survived. For operations in Asia Minor she subsequently raised an Armenian volunteer army, and swept into it refugees from Turkish territory. From 1914 to 1921 Armenians were

fighting incessantly in Asia—for Russia; for the French in Cilicia and Syria, where many thousands were embodied; and for themselves in Trans-Caucasia. Probably not less than one-sixth of the males of the whole race perished in warfare, in addition to loss by massacre and deportation.

*Russian Policy.*—A brief outline must now be given of the military operations of Tsarist Russia against the Ottoman Empire during 1914-6, for they deeply affected Armenia and the Armenians. For more than two centuries it had been the traditional policy of Russia to obtain possession of Constantinople and the waterway between the Black Sea and the Mediterranean. In the last 40 years she had seen her line of approach through the Balkan Peninsula made impracticable. Correspondingly her line of approach from Trans-Caucasia had gained immensely in importance. She had further established her naval supremacy in the Black Sea over any Turkish force that could be concentrated in those waters. With this as her policy, and in these circumstances, Russia, both openly and covertly, opposed all measures encouraging the development of Armenian national sentiment and aspirations, not only among the Armenian population under her rule in Trans-Caucasia, but also in Turkish Armenia. Tsarist Russia, in fact, desired Armenians in Turkey to remain a discordant disintegrating element in the Ottoman Empire, particularly in the eastern vilayets, until such time as she should be able to make further annexations. An independent Armenia, it thus appears, was impracticable during the existence of Tsarist Russia.

When war broke out between the Allied Powers and Turkey Russia recognized that the supreme opportunity for achieving her dearest ambition had arrived. Following the decision of the British and French Governments to send a military expedition to the Dardanelles, she made a formal request to her Allies that her claim to possession of Constantinople and the Straits at the conclusion of the war should be admitted in advance. A week later the Western Powers agreed to the proposal, and the destiny of the greatest strategical position in the world, and with it the destiny of Armenia, seemed to be definitely settled.

*Russian Invasion of Turkish Armenia, 1914.*—Russian troops crossed the frontiers on Nov. 4 1914, two days after the declaration of war, and advanced towards the great Turkish fortress of Erzerum. But the movement had no weight; it ceased after a few weeks of indecisive fighting, and the Turks launched a daring counter-offensive against Ardahan and Kars, in Russian Armenia. This reckless movement was ended, however, by the battle of Sarikamish (Dec. 29 1914 to Jan. 1 1915) at which, and at the battle of Kara Urgan in the subsequent retreat, the Turkish army was almost destroyed. In revenge for the disaster, attributed by Enver Pasha and the Young Turks to Armenian elements in the Russian army, and to support and intelligence given by Armenians generally, exterminatory measures against the Armenian population of Asia Minor were redoubled at the beginning of April 1915. It was at this stage that the British and French Governments issued (May 24 1915) a declaration that they would hold Ottoman ministers personally responsible for the massacres.

*Armenian Troops in the Russian Armies.*—Here it may be remarked that when Russia mobilized in Aug. 1914 for the World War, her Armenian troops, numbering, it is said, more than 120,000 men, were despatched to European fronts. When war with Turkey demanded great armies in Trans-Caucasia these troops were not available. But as a matter of policy Russia raised an auxiliary volunteer army of Armenians, including many thousands of refugees from Asia Minor, for service against the mortal enemy of their race. To these and other Armenians in the Russian armies of Trans-Caucasia—natives of the region, inured to its climatic conditions, between them familiar with every road and mountain path, and animated by every incentive to fierce and resolute combat—must be credited no small measure of the success which attended Russian arms against the Turks. Not without cause did Turkish leaders attribute their Caucasian disasters to their Armenian enemies.

*Capture of Erzerum.*—Stagnation followed on the Erzerum front for more than a year after the battle of Sarikamish. But during the spring and summer of 1915 a Russian army, operating in the neighbourhood of Lake Van, invaded and occupied the greater part of the Turkish vilayets of Van and Bitlis, peopled largely by Armenians. This southern campaign, however, had no serious importance except to distract Turkish attention and save an Armenian population. The one line of military advance from Trans-Caucasia into Asia Minor lay through Erzerum; and Russia was preparing for an unexpected spring upon this eastern bulwark of Anatolia. A great Russian army, including Siberian and Armenian troops, was concentrated within striking distance of the Erzerum position in the middle of winter. It advanced on Jan. 11 1916, and two weeks later had reached the outposts of the fortress, a march of some 80 m., with guns and supplies, through deep snow, at high altitudes, in temperatures often below zero. On Feb. 14–16 various commanding mountain forts, the main defences of Erzerum, some of them 9,000 ft. above sea-level, were taken by storm. The city was captured on Feb. 16—its fall a resounding disaster for the Ottoman Empire.

*Invasion of Anatolia.*—When the spring of 1916 came the Russians continued their operations westward, and by the end of July had captured the Black Sea port of Trebizond and the important military position of Erzinjan. They had reached a line about 30 m. west of Erzinjan, stretching from the Black Sea to the Euphrates and thence eastward to Lake Van and the Persian frontier, a line embracing the chief areas of Armenian population in Asia Minor. The line so held was nearly the same as that subsequently awarded by President Wilson as the western and southern frontiers of Armenia.

*The Russian Collapse.*—But this was Russia's farthest. She was weakening at home, where symptoms of upheaval were already appearing. On March 14 1917, a Provisional Government was proclaimed; the Tsar abdicated the following day; in September Russia was a republic, and on Nov. 17 Lenin and Trotsky seized the reins of power. The Treaty of Brest Litovsk, in which Germany imposed terms on her beaten and exhausted enemy, was signed on March 3 1918. The armed forces of Russia engaged in the war in western Asia lost their fighting value in 1917. The fleet at Sevastopol mutinied in June of that year and removed its officers; and the armies in Asia Minor were in process of disintegration at the same time. When the treaty of Brest Litovsk was signed these armies were only held together by the great personal influence of the Grand Duke Nicholas, viceroy and commander-in-chief in Caucasia, but had already voluntarily retired behind the Russo-Turkish frontier of 1914.

*Treaty of Brest Litovsk.*—In the Treaty of Brest Litovsk Turkish claims were not overlooked, in fact the treaty gave fulfilment to some of the wider ambitions which had developed in the Young Turk party. It provided, in effect, that between Russia and Turkey the frontiers should be those existing prior to the Russo-Turkish War of 1877–8; under this provision, therefore, the old provinces of Ardahan, Kars and Batum were to be returned to Turkey. Of these, Ardahan and Kars formed part of Russian Armenia, or Erivan.

Even prior to the signing of the Treaty of Brest Litovsk Turkey had been able to take advantage of the growing weakness of Russia. As early as Aug. 1916 she had recaptured the towns of Mush and Bitlis. But immediately after the signature of the Treaty she pushed her troops forward and between March 12 1918 and April 27 reoccupied in rapid succession Erzerum, Sarikamish, Van, Batum and Kars. The liberation of Turkish Armenia by Russia had failed, and the disaster involved the return to Turkish rule of a large part of Russian Armenia. The only hope for the Armenian people now lay in themselves—in whatever of wise provision, unity and sacrifice they could command.

*Federal Republic of Trans-Caucasia.*—Steps in the right direction had, indeed, already been taken. The approaching collapse of Russia became apparent to Trans-Caucasian people

early in 1917. On Sept. 20 1917 a Council of the Trans-Caucasian Peoples—of Armenia, Azerbaidjan and Georgia—assembled at Tiflis, proclaimed Trans-Caucasia a Federal Republic, and formed a Provisional Government. When Turkey, after the Treaty of Brest Litovsk, proceeded to overrun western Trans-Caucasia this Government attempted to negotiate a peace but found the endeavour fruitless. Not only were the Turkish leaders obdurate but the republic had no real unity among its parts. Azerbaidjan, with a Moslem population, though desirous enough of maintaining its independence, saw no great danger in Turkey recovering lost provinces at the expense of the Christian Armenians of Erivan; Erivan feared veiled annexation by Georgia under the guise of federation; and all three peoples were widely at variance upon questions of territory to which each thought itself entitled.

On April 13 1918 the Federal Republic broke off relations with Turkey and declared war, two days later the Turks occupied Batum, and on April 22 the Council of the Republic decided to proclaim its independence, but also to resume negotiations with Turkey for peace. With such waverings of policy the republic was likely to be short-lived.

The end came even sooner than was expected. On May 26 1918 the three states of the republic fell apart, each declaring its independence as a separate republic, and organizing a national Government of its own.

*Armenian Republic of Erivan.*—We now reach the point where the story of Armenia, hitherto the story of a dispersed people without a country, crystallizes into a story of an independent Armenian state—a state born to misfortune and bloodshed, surrounded by enemies, and inaccessible to its friends, a state whose survival and growth are matters more for hope than for confidence.

The territory of the republic of Erivan, excluding the districts in dispute with the adjoining republics of Georgia and Azerbaidjan, comprised the two Russian provinces of Erivan and Kars, possessing an area of some 17,500 sq. miles. By the census of 1916 these provinces contained, in round figures, a population of 1,570,000 of whom 795,000 were Armenians, 575,000 Moslems, and 140,000 of various other races. But the effective territory and population of the Erivan Republic were even less at the time its independence was declared, for nearly one-third of its whole area was in Turkish occupation under the terms of the Treaty of Brest Litovsk. *De jure* recognition, however, was accorded the republic by the Allied Powers.

Outside the confines of the state so indicated lay other territories claimed by it, but claimed also by Georgia or Azerbaidjan. Rather more than 2,000 sq. m. were thus in dispute with Georgia, and some 12,000 with Azerbaidjan. The census of 1916 gave the disputed areas a population of about 900,000, equally divided between Armenians and Moslems. Part of the area claimed both by Erivan and Azerbaidjan were the mountainous districts of Zangezur and Karabagh, peopled by Armenian highlanders, perhaps the finest representatives of their race. These, however, were separated from Erivan by an area in which a Moslem population predominated.

At best the territory occupied by the republic was an unfruitful region of treeless mountains and valleys containing little cultivated land, few resources, and a people reduced to the edge of poverty. Even in time of peace it had raised barely sufficient food for the needs of its thrifty population, but now when 400,000 refugees had poured into it, chiefly from Turkish Armenia, the question of supplies became more and more acute. The existence of the republic, indeed, was eventually affected by the difficulty of obtaining supplies, not only of food but of munitions and fuel.

But the republic was faced with many other difficulties, some external, others internal; the greater number immeasurably intensified by the country's unfortunate geographical position. Erivan was, in fact, an Asiatic Switzerland, though far more remote from the sea and more inaccessible. The only line of railway communication towards the western world ran through Georgian territory to the Black Sea port of Batum, the only roadway to the sea was also through Georgia to Batum. And

Batum at this time was in the hands of the Turks, and the Allies were still shut out from the Black Sea.

External difficulties were the active and veiled hostility of neighbouring states. Between Erivan and Turkey was the traditional hatred of Armenian and Turk, now inflamed to the desperation of a life-and-death struggle. Between Erivan and Azerbâijân was the standing enmity of Armenian and Moslem, given definite point by the massacre of Armenians at Baku some 15 years earlier, and of Moslems by Armenians during the months following the declaration of Armenian independence. There was also the acute question of territory in dispute, accompanied by incessant border fighting. Between Erivan and Georgia trouble, at the moment, was chiefly upon opposing territorial claims. Another hostile external influence was, a little later, exerted by Gen. Denikin and his supporters, who aimed at destroying the independence of the Caucasian republics and reuniting them to a resurrected Russia.

Internal difficulties, apart from poverty and questions of the supply of food, clothing, munitions and medical stores, were caused, also, by the absence of administrative experience among Armenian leaders and the sinister influence wielded by the Dashnakists. This Armenian secret revolutionary society held an extreme socialism; it was thus to a large extent in sympathy with the Bolsheviks of Russia. At the same time it stood for an aggressive military policy by the Erivan Republic and the extension of territory at the expense of adjoining states.

*British Expedition to Baku.*—Operations which might have had far-reaching results for Erivan and other Caucasian states led to the occupation of Baku in the republic of Azerbâijân, on July 28 1918, by a small British force. It had come from Mesopotamia through Persia, and thence up the Caspian Sea—a hazardous expedition intended to prevent, if possible, the despatch of German or Turkish detachments from Caucasia into Central Asia, and to open communications with the Caucasian republics. It had relied upon receiving local Armenian support at Baku, but this hope failed owing to the extreme war-weariness of the Armenian population. The Turkish troops which had already entered Azerbâijân received reinforcements early in September, and then attacked the town and compelled the British force to re-embark on Sept. 15.

*Armistice of Mudros.*—The Armistice of Mudros, signed on Oct. 30 1918, ended hostilities between the Allied Powers and Turkey. Better days seemed now to be in sight for the Armenian race. Turkey was crushed, the Young Turk Government had fallen into disrepute, the chief leaders were in flight, and it was the avowed purpose of the Allies to free the subject races of the Ottoman Empire from Turkish rule. The Armistice contained conditions that speedily relieved the position for Armenians. The Straits were opened, Allied warships reached Caucasian ports and Allied and American relief work was begun. Trans-Caucasia was to be evacuated by Turkish troops, an Allied garrison placed in Batum and elsewhere if necessary, and Armenian prisoners-of-war and interned Armenians released forthwith. Another clause provided for Allied occupation, in whole or part, of the six Armenian vilayets of Asia Minor in case of disturbances arising.

*War Between Georgia and Erivan, 1919.*—The collapse of Germany and the Armistice of Nov. 11 1918, marking the complete victory of the Western Powers, seemed to promise the eventual creation of an Armenian state containing a majority of the race. But with Turkish occupation ended the Caucasian republics fell out more seriously among themselves. In spite of Allied efforts to prevent hostilities war broke out between Georgia and Erivan in Jan. 1919; fighting also continued between the Armenians of Karabagh and Moslems of Azerbâijân. At this time, too, the intrigues attending Gen. Denikin's movement went far to embroiling the republics. These unfortunate struggles did not, however, last long, nor were military operations undertaken on a serious scale, but the old causes of enmity remained, increased now between Georgia and Erivan by disputes regarding use of the Batum-Erivan railway, and the customs dues levied by Georgia on goods for Erivan.

*Paris Peace Conference.*—On Jan. 19 1919 the Peace Conference at Paris began its deliberations, from which, when Eastern problems could be reached, it was hoped that a satisfactory settlement of Armenian affairs might emerge. Each of the Caucasian republics was permitted a delegation to lay its claims before the Conference. Meanwhile the Supreme Council, acting as an executive body, despatched an Allied High Commissioner to Erivan to compose, if possible, the urgent differences between the rival republics.

Armenians of Erivan had agreed to join Armenians of Turkey in seeking the creation of a single Armenian state; the Armenian delegation at Paris therefore represented the whole Armenian race. The claim advanced by the delegation was, in brief, that to Erivan should be added the eastern districts of Asia Minor in which a considerable Armenian population had existed prior to 1914, and that these districts should include Cilicia as being the "Lesser Armenia" of mediæval history.

But this comparatively moderate proposal bristled with difficulties, and traversed principles to which the Conference professed adherence. Ancient and mediæval history offered feeble arguments for the recovery of territory from a race which could show effective occupation for the past 400 years. Nor did any juggling with ethnological figures assist the Armenian case, for the plain fact remained that in no vilayet of Asia Minor, even before the massacres and deportations, was there an Armenian majority over Moslems. The principle of self-determination by inhabitants would therefore, if applied, destroy Armenian claims.

The Armenian case stands, indeed, on firmer ground than doubtful historical sanctions and self-determination by a mosaic of local populations. Based on justice and high expediency it becomes a cause which no amount of theory can set aside.

Stated plainly the case for Armenia put forward by the delegation was that by race, language, faith, old history, services in the Allied interest, and barbarous treatment at the hand of the Ottoman Government over a long period, the Armenian people had shown themselves entitled to separate existence as an independent nation. And further, owing to their numbers having been artificially reduced by calculated and systematic massacre, justice required that their dead should be taken into account against the principle of self-determination within any Turkish territory to be allotted to an Armenian state. Expediency lay in the prospect that by the erection of an effective Greater Armenia a definite settlement of the Armenian problem would follow—a problem likely, otherwise, to remain insoluble. And yet more, that an Armenian state, extending from the Black Sea to the Mediterranean, would, with Allied aid, soon become a stable, self-reliant, civilized power in the midst of one of the chief danger-zones of the world.

The chief difficulty confronting the Armenian proposal was that the state to be created could not at first stand alone. It would require large financial and military support to set it on its feet and to maintain it during the earlier years of its existence—it was doubtful even if it could police its own territory at the outset. These difficulties were to be overcome, it was hoped, by placing the proposed state in the charge of a mandatory Power.

Throughout the year 1919 and the earlier half of 1920 the prospect of finding a Power who would undertake the onerous and costly task of mandatory grew less and less favourable. It had been hoped that America would accept the responsibility. The American people had shown much sympathy with the Armenian cause; politically America was disinterested and stood outside the jealousies of European powers; her prestige was great; her resources unimpaired; to the Armenian people she would have been their first choice as mandatory power. But the American Senate rejected the offer, fearing entanglement in Old World affairs. Great Britain, France, Italy, each felt unable to undertake the position—war had left them more or less exhausted; and their peoples would not incur the certainty of additional outlay of blood and resources. The Supreme Council

proposed that Armenia should be placed under the League of Nations; the League decided that the acceptance of mandates did not fall within its purpose. And when, at a later date, Armenia applied for admission to the League membership was refused her.

*Treaty of Sèvres and Armenia.*—The Treaty of Sèvres, imposed upon Turkey and signed on Aug. 30 1920, provided for the creation of an enlarged Armenian state and for the settlement of its boundaries. In Caucasia they were to be adjusted by direct agreement between the states concerned or, in failure of that method, by the Allied Powers. In Turkey they were to be defined by President Wilson as arbitrator; and the Treaty bound Turkey to accept his decision, but limited the area subject to award to the whole or parts of the vilayets of Trebizond, Erzerum, Van and Bitlis. The interests of Armenians remaining in Turkish territory were safeguarded under the Protection of Minorities clauses of the Treaty.

*President Wilson's Award.*—The award defining the Turkish frontiers of Armenia was given by President Wilson in March 1921. It assigned to Armenia the greater part of the vilayets of Trebizond and Erzerum, and the whole of the vilayets of Bitlis and Van—in all an area of about 30,000 sq. miles. The award gave the territory essential to the creation and development of a self-supporting state. It included the greater part of the eastern districts of Asia Minor containing the bulk of the Armenian population in Turkey. It provided a coastline for the state of about 150 m., and included the historic seaport of Trebizond on which north-eastern Asia Minor depends for access to the sea. And while fulfilling these conditions it brought within Armenian territory as small a proportion of Turkish Moslems as might be.

*Wrecking of the Award.*—But however admirable in itself, President Wilson's decision took Armenia little further towards actual possession of the territory awarded under the terms of the Treaty of Sèvres. The Peace Conference might assign the territory by treaty the Turkish Government at Constantinople might accept and sign the treaty; and President Wilson might define the boundaries, but for Armenia to gain possession was another matter. It was on this difficulty—a difficulty to be overcome only by use of a great military force—that the fair prospect of an enlarged and independent Armenia was wrecked.

Even before the acceptance of the Treaty of Sèvres by the Constantinople Government the Turkish Nationalist movement had appeared in Asia Minor. Its chief purpose was to offer armed resistance to the execution of any treaty involving the transfer of Ottoman territory to Greece and Armenia. Whether the movement originated with the discredited Young Turk leaders or was a genuine movement recognized by them as a promising means to their own restoration to power, is not clear. But the movement grew rapidly in strength. Within a year the Nationalist Government, organized at Angora, was sovereign not only in Asia Minor, but had overshadowed the Constantinople Government and become the real rulers of the whole of Turkey. And as the movement gained in strength so the old Young Turk leaders reappeared—Tal'at Pasha, Enver Pasha, Kemal Pasha, and others—promoting an alliance with Bolshevik Russia; urging Pan-Islamic ambitions, and apparently forming with their followers the extremist Left wing of the Nationalist movement. To suppress this rival Government, even had there been no secret concord between the two, was beyond the power of the Government at Constantinople. Nor were the Allied Powers in a position to enforce a treaty by a great new war involving vast expense. Still less was any single Power willing to undertake the task. Beaten and dismembered though the Ottoman Empire was, there still remained in Anatolia a reserve of strength, which, in combination with the great military difficulties presented by the country, and aided by Bolshevik Russia, was able to defy and thwart the decisions of the Peace Conference.

Greece, indeed, her own territorial gains at stake, and supported by the Allies, commenced military operations against the Nationalists in May 1920; and it seemed probable that the Armenian cause might benefit. The republic of Erivan there-

fore prepared to send troops into the territory assigned her by the Treaty of Sèvres, and desultory fighting occurred. Turkish strength in eastern Asia Minor, however, was too great for the small force Erivan could spare from other fronts to have any prospect of success, and no actual invasion of Turkish territory took place. Meanwhile Greek armies encountered little resistance and occupied a large area of western Asia Minor. These operations, however, in no way crushed the Nationalist power.

In Feb. 1921 Greece undertook yet greater operations; this time unsupported by the Allies, and in defiance of their wishes. She aimed at destroying the Nationalist forces and capturing Angora; but by the end of March her armies were driven back, and she found that an offensive on a vastly greater scale would be necessary to ensure success. To this yet more serious campaign she definitely committed herself in the summer of 1921.

*Bolshevik Invasion of Caucasia.*—To complete this historical sketch, it is only necessary to glance more particularly at the unhappy events in Caucasia and south-eastern Asia Minor during 1920-1, for in this period the tragedy of the Armenian race seemed to have reached its climax.

The Bolshevik occupation of Baku, at the close of April 1920, ended the independence of the republic of Azerbaidjan and established a Soviet Government in alliance with Moscow; it also brought Bolshevik forces into an area whence they could apply pressure to Georgia and Erivan. Bolshevik Russia and Nationalist Turkey were even now working together. Apart from strictly Bolshevik aims the common purpose existed of establishing direct communication between Russia, via Baku, and Nationalist Turkey. This could only be done through Erivan and Georgia by railway, or through Erivan by road; the republic of Erivan, in fact, completely barred both routes. In spite of Bolshevik propaganda in Erivan the people as a whole were strongly opposed to Bolshevism, and when in May Bolshevik forces in Azerbaidjan attacked Erivan they encountered a vigorous defence, and were repulsed. Moscow now endeavoured to negotiate a treaty of alliance with Erivan, but the terms offered were too severe. They included—the right of transit through Erivan by rail for Soviet troops, the cession of the disputed districts of Karabagh, Zangezur and Nakhichevan to Bolshevik Azerbaidjan, and the control of the foreign policy of Erivan by the Moscow Soviet. Erivan refused, but in July was served with an ultimatum requiring it to evacuate the three districts just named.

The isolated republic had been in desperate straits for food, fuel for its railways, munitions and clothing for its troops; but supplies of munitions and uniforms, sent from England, reached the country just before the ultimatum was presented. For allowing the passage of these vital supplies through Georgia that republic, however, had insisted on retaining 20% of everything by way of toll.

While Soviet Russia applied pressure upon Erivan from the east, Nationalist Turkey did likewise from the west. The outcome was that the republic agreed to the occupation of Karabagh, Zangezur and Nakhichevan by Bolshevik troops, thus giving direct road communication between Azerbaidjan and Nationalist Turkey. With the very existence of Erivan thus threatened and conscious that the same danger hung over their own country the Georgian people might have been expected to make common cause with their Armenian neighbours. The danger, however, seemed to them less; they had open communication by sea and could, they thought, await developments. They mobilized troops on their frontiers; but gave no active assistance to Erivan.

*Fall of Republic of Erivan.*—By Sept. everything was in readiness for the next act in the tragedy. At the end of the month a Turkish Nationalist army suddenly attacked and captured Oltu on the western frontier of Erivan. In the meantime Bolshevik forces in Azerbaidjan were massed along the railway skirting the northern frontier of the unfortunate Armenian Republic. An overwhelming Turkish advance was then made along the railway upon the great fortress of Kara in the heart of Erivan. Armenian troops checked the advance for a time, and

compelled a Turkish retreat, but it was only a temporary setback; Kars fell, and the advancing Nationalists captured Alexandropol in November. Bolshevik rings broke out in the capital and other towns, the resistance of the republic collapsed, and the city of Erivan was speedily occupied by Turkish troops. At this stage a Soviet Government was set up, and the republic of Erivan became, in name, a Soviet Republic in alliance with Moscow. But even so it was a republic much reduced in area. In agreement with Moscow Turkey took possession once again of the districts of Kars and Ardahan, from which the Allied Powers had ejected her in Nov. 1918, and to this territory was added enough to bring the railway from Azerbaijan to Erzerum within Turkish possession. Only in the region of Karabagh was any vestige of Armenian independence preserved, there, indeed, the Armenian mountaineers repudiated Soviet Government and, so far seem to have retained a precarious but independent existence.

With Turkish forces in occupation of Erivan, a state which had striven to form a Great Armenia by the acquisition of Turkish territory, massacre might have been foretold. It was hoped, however, that Soviet influence would prevent great bloodshed, but the hope had no real ground for existence. At Olti, Kars, Alexandropol, and then in the city of Erivan, massacres on a scale comparable only with those of 1915-6 took place, and if this policy was followed in the towns it was followed in the villages as well. The total loss of life cannot be estimated, but was certainly great. When the snow melted in the spring of 1921 thousands of Armenian corpses were revealed, heaped together, just as they had fallen in the closing months of 1920.

*Cilicia and S. E. Asia Minor.*—In Feb. 1920 Turkish Nationalist forces began serious operations against Cilicia, then in occupation by French troops as part of the French sphere of influence. They defeated various French detachments, captured the large town of Mar'ash, and there, and elsewhere in Cilicia as opportunity offered, resumed a systematic massacre of the Armenian population. The position was the more disastrous because, relying upon French protection for the future, a great immigration of Armenians into Cilicia had taken place; it was credibly reported, indeed, that some 20,000 of the race perished in south-eastern Asia Minor during the spring of 1920. At this stage the Allied Powers, who had recently decided that Constantinople should remain in Turkish hands, threatened to reconsider their decision unless effective Turkish protection were given to non-Moslem elements of the population in Asia Minor. The warning seemed to have some effect at the time, though later developments diminished its influence.

A definite Nationalist policy lay in the Cilician operations, however haphazard and casual they may appear. The idea had been broached, chiefly among Armenians, of creating a Franco-Armenian State in south-eastern Asia Minor—of, in fact, reviving the Lesser Armenia of history, and placing it under French protection. The hope that this scheme would mature was one of the influences which brought a large Armenian population into Cilicia in 1919. Nationalist operations in this region were designed to thwart the project by exterminating the Armenians, and involving the French in irritating and costly hostilities in defence of the territory. Warfare on a small scale continued during the greater part of 1920; for not only had the French their hands full in Syria, but they were anxious to avoid pushing matters to extremes with the Nationalists. They hoped, in fact, for an arrangement.

*Siege of Hajin.*—One of the most unhappy affairs of the Cilician War was the siege and capture of Hajin by the Nationalists. The town, a remote Armenian stronghold among the Anti-Taurus mountains, was held by its inhabitants against all Turkish attacks until Oct. 1920. Ammunition, however, ran out; expected relief never came; and in the end the town was stormed, and the greater portion of the population, numbering several thousands, perished in the usual massacre.

*French Negotiations with Nationalists.*—At the beginning of 1921 the French and the Nationalists came to an agreement by which, in return for important economic concessions in

wide areas of Asia Minor, France was to vacate Cilicia. The National Assembly at Angora refused to ratify the agreement, on the grounds that it surrendered too much and obtained too little. They desired, in fact, possession of the port of Alexandretta which the French had retained. Negotiations, however, were continued. The hope that a Franco-Armenian State might be established in Cilicia had small prospect of realization unless a change should take place in French policy in these regions. (W. J. C.\*)

**ARMIN, FRIEDRICH SIXT VON** (1851— ), German general, was born at Wetzlar Nov. 27 1851. He took part in the war of 1870-1 and was severely wounded at St. Privat. After having occupied different positions on the General Staff, he was appointed in 1903 Director of the General Department of War in the Prussian War Ministry, and in 1911 General-in-Command of the IV. Army Corps at Magdeburg. During the World War he led his corps as a part of the First and of the Sixth Army; he was appointed in 1917 Chief-in-Command of the Fourth Army in Flanders, where he succeeded, in the spring offensive in 1918, in taking Armentières and the Kemmel Hill. At the close of the war he retired from the army.

**ARMOUR, [JONATHAN] OGDEN** (1863— ), American merchant and capitalist, was born in Milwaukee, Wis., Nov. 11 1863. Preparing for college in Chicago, where his father, Phillip D. Armour (*see* 2 378), was a pioneer in the meat-packing industry, he entered Yale in 1881 but did not finish his course. In 1883 he entered the business of Armour & Co., and was made a partner the following year. After the death of his father in 1901 he became president and general manager of Armour & Co., which had been incorporated in Illinois in 1900. Under his guidance the business widely expanded. In 1918 in the United States alone it owned 14 slaughtering plants and 392 branch houses, with refrigeration capacity of 15,170 tons per day, the sum paid for live stock in one year was \$517,951,026. The company was also engaged in the preparation of by-products, such as fertilizer, glue, soap and hair. Total sales grew from about \$250,000,000 in 1910 to about \$1,038,000,000 in 1919, total net income from \$9,808,303 to \$27,186,124. On Feb. 27 1920 an agreement with the Government, resulting from a threatened suit, was filed in the Supreme Court of the District of Columbia requiring Armour & Co. (as well as Swift & Co., Morris & Co., Wilson & Co. and the Cudahy Packing Company, all together popularly called the "Big Five" packers) to begin immediately and within two years finish the sale of "all their holdings in public stock-yards, stock-yard railroads and terminals, and their interests in market newspapers and public cold-storage warehouses, and forever to disassociate themselves from the retail meat business and food lines unrelated to meat packing." This would restrict them to wholesale business in meat, poultry, eggs, butter and cheese.

**ARMoured CARS.**—The armoured car is a mechanically propelled vehicle equipped with protective armour and adapted as a fighting machine. Its first form consisted of a motor chassis with iron-plated sides fitted with loopholes for the crew to fire from. It rapidly developed into a miniature armoured fort on wheels with machine-guns and searchlights mounted in the most effective manner. This first type was liable to be put out of action by bombs thrown over the iron plating or from the windows of houses, and the iron plating was not proof against modern high-velocity rifle fire. The next improvement, therefore, was to place armour over the top. It was soon found that the requirements in the armament and arrangement of armoured cars were similar to the practice in the navy, and that, provided a car could be kept mobile, the next main essentials were a good range of observation and an all-round field of fire. This soon produced the turreted cars, with a single revolving turret and one Vickers machine-gun; and subsequently a type of car with two turrets abreast of each other, and containing each a Hotchkiss gun, was evolved. The advantage of a second gun in action was evident when it was found that bullets hitting the single gun penetrated the water jacket and thus rendered the gun useless. On the other hand the extra weight of the double turret placed a load on the chassis, which was already loaded

to its full capacity in order to carry armour that would be proof against modern fire.

The use of the armoured car is limited to the roads, although in some seasons in open countries it is possible to operate over large areas of terrain away from the roads. Obstacles can hinder the progress of cars to a certain extent, but with determined and skilful drivers, and well-trained crews, there are very few roads over which cars cannot be taken. In civilized warfare the maintenance of large armies necessitates roads being kept open for wheeled transport, and once the line formed by the fighting troops is overcome there is very great scope for the employment of armoured cars if placed under the control of a skilful and enterprising commander.

At the outbreak of the World War in 1914 several well-designed types of armoured cars were produced, but the enormous demands for motor transport on the part of all the combatants to equip their rapidly increasing forces prevented the production and development of armoured cars in sufficient numbers to do effective work at the beginning of the war. During the fighting in the autumn of 1914 there were many opportunities for their use, and a few naval cars and some small units did very useful work in France and Belgium, but when the armies on the western front settled down to trench warfare the blocking of the roads prevented the further effective use of armoured cars on that front. The armoured cars that had been made were then sent to the distant fields of operation in Egypt, Mesopotamia, East and South-West Africa, while the detachment of naval armoured cars that fought in Belgium were employed in Rumania and southern Russia, where they were almost the only representatives of the British army in those countries. During the periods in which the contending armies were stationary and gathering their forces for the decisive contest there was no scope for the armoured cars, owing to the shell-torn roads, trenches and barbed wire, but the value of the armoured protection, mobility and fire-power of the armoured car contained the basis of the idea which was to have considerable effect on the latter phases of the war. In the stationary warfare of trenches the deciding factors were machine-gun fire, wire and mud. The armoured car could withstand the first by its armour protection, and could return it on equal terms with its own machine-gun fire. If it could be made to cross mud and wire the attack could then meet the defence of trenches on more than equal terms. The best machine for crossing soft and broken ground at that time was the tractor with the endless steel belt, and by a compromise of the armoured car and the tractor the British tank was evolved (see TANKS).

Under peace conditions armoured cars form an essential part of most standing armies. As a means of policing the enormous areas in which the British army is responsible for keeping the peace the armoured car provides a unit which can be kept mobile, ready to move at the shortest notice, and can cover the greatest distances with the minimum fatigue and the maximum speed. It can only be exceeded in these respects by the aeroplane, but, unlike that machine, the armoured car unit can provide the armoured protection of a miniature mobile fort, equipped with machine-guns, searchlights, a plentiful supply of ammunition, food and water, that can hold its ground until a well-organized and well-equipped enemy has been assembled to meet it. In cases of civil disturbances, apart from armed rebellion, the armoured car provides a means by which the civil forces of the law can penetrate into the middle of a crowd in a way that would be impossible under ordinary conditions of police duty.

**ARMoured TRAINS.**—In the earliest days of the application of railways to war uses, the idea presented itself both to inventors and to practical soldiers of utilizing the weight-carrying capacity of the railway and the pulling power of the locomotive for tactical as well as for strategic purposes. "Railroad batteries" figured in the American Civil War, and in the war of 1870; and armoured trains have appeared thereafter sporadically in most wars. Their utility, though it was confined within rather narrow limits, was unquestionable until the development

of mechanical road transport. Nowadays, however, in countries where the rail system is sufficiently developed to give such trains real freedom of movement there exists an even fuller system of main roads on which armoured cars can operate, and in the World War period the fighting train has only figured in such theatres as those of the Russian civil wars, in which roads fit for heavy traffic are as a rule rarer than railways. As against the armoured car working on good roads the train must always suffer from being limited to certain tracks which are very easily interrupted by raids, air bombing, or artillery fire, and in the future, as cars of the four-wheel drive or caterpillar types improve, the freedom of movement of the armoured car cannot but increase even in theatres of war in which roads are few. Considered as a self-contained fighting unit, therefore, it is improbable that the armoured train will be of much practical utility in the future.

On the other hand, the old "railroad battery" considered as a form of gun-mounting possessed, and more than ever now possesses, many intrinsic advantages over other forms of mounting heavy ordnance for field warfare. In the well-laid bed of a railway track, organized to distribute heavy strains equally, such mountings have their firing platform ready made, and the power of the locomotive gives heavy artillery a mobility that otherwise it would lack. In this form, then, the train represents the battery vehicles of horsed or motor artillery. The central member is the heavy truck carrying the gun, and the others are arranged for ammunition and for the accommodation of the gun personnel. Light armour is frequently used for the protection of the vehicles against shrapnel bullets, and in some cases the gun itself is provided with a shield. These railway mountings are referred to under **ORDNANCE**.

**ARMOUR PLATE** (see 2.578).—The history of armour plate during the years 1909-21 differs from that of most other materials used in warfare, inasmuch as the period of greatest progress and activity occurred before the World War and was followed by a period of rest amounting almost to stagnation. The actual years of the war, which constituted a period of intensive culture as regards guns, shell, airships, aeroplanes, tanks, etc., added no stimulus to progress in the manufacture of armour plate. The efforts of British shipbuilders were devoted to the building of light, fast cruisers and destroyers for which there was urgent and immediate need, rather than to heavily armed battleships which would take three years to complete.

During the years immediately preceding the war, however, the manufacture of armour plate had made steady progress, and the improvement in quality was marked. There were no radical alterations such as the employment of a new alloy steel, or the introduction of a new process of manufacture; but in the application of scientific principles to the details of manufacture, and the various heat treatments through which the plate passes, immense improvements had been made and were apparent in the quality of the finished plate. In this connection it can be recorded that a long series of trials have proved beyond doubt that British armour made immediately before the war was greatly superior in ballistic qualities to that manufactured in Germany, in spite of the fact that the process of armour-plate manufacture originally came from Germany. For example, a German 12-in. plate was found to be no better than a British 9-in. under the same test, while a German 10-in. plate was only equal to the British 8-in. The plates tested were taken from the ex-German battleship "Baden," and are therefore thoroughly representative of the German product.

TABLE I.—British and German Armour

Thickness of plate in lb. per sq. in.	Index number representing limiting velocity of penetration	
	British	German
320 lb. armour	1,000	940
400 " "	1,000	less than 895
480 " "	1,000	less than 835
560 " "	1,000	915

In Table I the average limiting velocity of penetration for British plates is taken to be 1,000 ft. per second in each case.

the third column shows the comparative figures for German plates. The projectiles used at these trials were of similar mark and quality to those used in testing British plates of the same thickness.

In the case of the 400 and 480-lb. plates the actual limiting velocities were not reached, the projectiles, at the velocities indicated by the index figures, passing through the plates in a practically undamaged condition. Tests carried out on turret roof plates of 160-lb. and 200-lb. thickness also showed a marked superiority in favour of the British plates. These results may be accounted for to some extent at least by the fact that the manufacture of armour in Germany was a monopoly, and to all intents and purposes a State monopoly, whereas in Great Britain there were five rival firms of manufacturers and an Admiralty always asking for something better.

The necessity for improvement has been constant owing to the introduction of larger and more powerful guns—the 13.5-in. in the ships of the 1909-10 programme and the 15-in. in those of the 1912-3 programme.

Tables II and III, compiled from information contained in a paper read by Sir Eustace d'Eyncourt before the Institution of Naval Architects, show the increase in the thickness of armour on British and German battleships in answer to the challenge of the new guns.

TABLE II.—British Armour v. German Guns.

Programme	Guns on German ships	Main armour on British ships	Gun-houses
1906-7	11 in. 45 calibre	10 in. and 8 in.	11 in.
1907-8	11 in. 45 calibre	10 in. and 8 in.	11 in.
1908-9	12 in. 50 calibre	11 in. and 8 in.	11 in.
1909-10	12 in. 50 calibre	12 in., 9 in. and 8 in.	11 in.
1910-11	12 in. 50 calibre	12 in., 9 in. and 8 in.	11 in.
1911-2	12 in. 50 calibre	12 in., 9 in. and 8 in.	11 in.
1912-3	12 in. 50 calibre	13 in. tapering to 8 in. bottom and 6 in. top.	13 in.
1913-4	15 in.	13 in. and 6 in.	13 in.

TABLE III.—German Armour v. British Guns.

Programme	Guns on British ships	Main armour on German ships	Gun-houses
1906-7	12 in. 45 calibre	11-8 in. tapering to 6.5 in.	11 in.
1907-8	12 in. 50 calibre	11-8 in. tapering to 6.5 in.	11 in.
1908-9	12 in. 50 calibre	11-8 in. tapering to 6.7 in.	11½ in.
1909-10	13.5 in.	13-8 in. tapering to 9 in.	11½ in.
1910-11	13.5 in.	13-8 in. tapering to 9 in.	11½ in.
1911-2	13.5 in.	14 in., 10 in. and 7.9 in.	14 in.
1912-3	15 in.	14 in., 10 in. and 7.9 in.	14 in.
1913-4	15 in.	13½ in. tapering to 10 in.	13½ in.

Any increase in the thickness of armour presents very serious problems to the naval architect on account of the great additional weight to be carried, and it is therefore of vital importance that the quality of the armour should be of the best. It is not only in regard to increase in thickness, however, that progress has been made. The superficial area of plates has also been increased, and plates measuring 15 to 20 ft. in length and 10 to 12 ft. wide are now not uncommon. Large plates are in fact a necessity in modern battleship construction. The striking energy of a large shell is so great that the resistance opposed to it must be distributed over as large an area as possible. As an example of the forces involved the striking energy of a 15-in. shell at a range of 10 m. is 30,000 foot tons or in other words its energy is equivalent to that of an express train weighing 250 tons and travelling at 60 m. an hour. There is grave danger, therefore, that a small plate, even if it succeeds in stopping the shell, may be driven bodily into the ship. Moreover, it is as true to-day as ever it was

that the weakest point in any armour is the joint. A heavy shell striking a plate near an edge or corner is liable to break off and carry away a piece of the plate with disastrous results, and it is therefore desirable to eliminate this risk as far as possible by reducing the number of joints to a minimum, that is to say by increasing the size of the individual plates. At the present time the size of plate capable of being placed on a ship is only limited by the carrying capacity of the railways.

No substantial alteration in the process of manufacture of armour has taken place since 1910, and the description given in the earlier article in this Encyclopædia requires neither modification nor addition. In other respects, however, much has been learned, and some of the views held in 1911 require revision. For example, the statement that "plates sometimes vary considerably and are not of uniform hardness throughout" can scarcely be said to be true to-day, in spite of the great increase in size of modern plates over those made in the years previous to 1911.

It is impossible to discuss improvements in armour plate without at the same time taking into consideration the improvements which have been made in armour-piercing shell, and also the changes which have taken place in the nature of the attack. Conditions during recent years have been constantly changing. The introduction of capped projectiles, and the substitution of "unbacked" for "backed" trials, each presented problems for the armour-plate manufacturer. Moreover it has only been possible to solve these problems by the laborious process of trial and error, for there is no exact knowledge on the subject, and theories (of which there are many) have proved sadly misleading. For example, the action of the cap has been, and still is, a subject for discussion. It was for some time believed that the action of the cap was only effective at velocities over 1,700 ft. per second, whereas actual experiment has proved that it is equally effective at velocities of 1,000 ft. per second and even less. Constant alterations in the size, weight, and design, as well as in the quality of steel used in the manufacture of the cap, have further complicated the problem from the armour-plate manufacturer's point of view.

Interesting as the theoretical aspect of the subject undoubtedly is, there are at present too many unknown factors, both as regards shell and armour, to enable it to be regarded as an exact science; and recent experience has only served to confirm the statement made by an early authority, Maj.-Gen. Inglis, R.E., in 1880, that "in no subject that has ever been raised has mere opinion unsupported by practical experience proved so worthless as in this."

**Bullet-proof Armour.**—While there was a lull in the activity of armour-plate manufacture for naval purposes during the war, there was greatly increased activity in the production of light or bullet-proof armour. When the armies on the western front dug themselves in and the fighting resolved itself into trench warfare there was an insistent demand for some means of protection for the men who had to face rifle fire at close quarters. Innumerable suggestions were made and a vast number of experiments carried out with a view to producing a bullet-proof material of reasonable weight. The ordinary service bullet, consisting of a cupro-nickel (or in some cases a mild steel) case filled with lead, breaks up fairly easily on a plate of hard steel, but the Germans soon discovered that if the bullet is removed from the cartridge and reversed (*i.e.* so that the bullet travels with the base or blunt end in front instead of the pointed end) it did not break up but punched a hole in the plate.

Every effort was made to defeat this attack, but it was found that even with the use of the best quality of alloy steel available a minimum thickness of half an inch was necessary to stop the reversed bullet at short range. All sorts of materials were employed, but steels were found to be the most efficient, and of these nickel, chrome, manganese, vanadium, molybdenum and zirconium, both singly and in combination, were all tried. The best results, however, were obtained from nickel-chrome plates, sometimes with an addition of one of the rarer metals.

While these experiments were being carried out in England the Germans were busy endeavouring to produce something



more satisfactory than the reversed bullet which was only effective at short range. In this they were completely successful, and they produced the K or armour-piercing bullet. This consists of an outer envelope of mild steel of the same size and dimensions as the ordinary bullet. In the centre of the envelope is the bullet proper, made of hardened tungsten steel 30 mm. long, 6 mm. in diameter, and pointed at one end. The space between the envelope and the hard bullet is filled with lead. On striking a hard steel plate the outer envelope breaks up, but it and the lead lining appear to perform the function of a cap, and the hardened steel bullet perforates the plate.

At ranges up to 60 yd. with a good rifle, and more than this with a rifle in which the rifling has been worn, the armour-piercing bullet is not effective, owing to unsteadiness in flight, but at longer ranges nothing less than half an inch of the best steel is of any use as a protection against a direct hit at the normal. The action of the armour-piercing bullet, however, differs from that of the reversed bullet. The former is a clean penetration of the plate, whereas the latter punches a hole and removes a portion of the plate in the form of a small cylinder. Both at long and short ranges, therefore, a plate of at least half an inch in thickness was found to be necessary to give any real protection, and as plates of this thickness weigh 20 lb. per sq. ft. it was obvious that a soldier could not carry his own means of protection in addition to a rifle and the other impedimenta which he took into action. It became necessary then to devise some mechanical method of carrying protection, and the combined efforts of many minds in this direction finally resulted in that weapon of offence and defence which was afterwards known as a "tank" (see TANKS).

From the nature of the requirements it will be seen that the practice of the armouring of the tanks was by no means an easy one. In the first place the plates in an untreated condition had to be soft enough to be easily machinable, while after treatment they were required to withstand the penetration of the armour-piercing bullet and the punching action of the reversed bullet. This necessitated a very hard plate, but on the other hand it was essential that they should be sufficiently tough to prevent cracking or the breaking off of portions of the plate even when struck near an edge or corner. In addition the plates were to be capable of being riveted to the body of the tank or to one another, and finally they must be of the minimum thickness, as the question of weight was all-important.

These requirements were met by the use of nickel-chrome steel, which possesses properties of hardness and toughness to a remarkable degree. Steel containing 0.3 to 0.5% of carbon with 3 to 4% of nickel and 1.5% to 2.0% of chromium was largely used, and in some cases improved by the addition of one of the rarer metals.

In view of the work which the tanks were designed to carry out it was of the utmost importance that they should be perfectly bullet-proof, and it is perhaps not generally known that every plate was tested by firing trial against the German bullet before it was built into the tank. Under this severe but necessary test a very high degree of excellence in the quality of the plates was attained. The manufacturers had their own rifle ranges where the plates were tested under Government supervision before they were dispatched. (E. F. L.)

**ARMSTRONG, SIR WALTER** (1850-1918), British art critic and writer, was born in Roxburghshire Feb. 7 1850. He was educated at Harrow and Exeter College, Oxford. On leaving the university he became well known as a writer on art, and his judgment of pictures was considered of great value. From 1880 to 1892 he was art critic to various newspapers, among them being the *Pall Mall Gazette*, *St. James's Gazette* and *Manchester Guardian*. In 1892 he became director of the National Gallery of Ireland, a post which he held for more than twenty years. He was knighted in 1899. Sir Walter Armstrong was more especially an authority on the Dutch 17th-century and English 18th-century periods. He was the author of many works on art, of which the chief are: *Gainsborough and his Place in English Art* (1898); *Sir Joshua Reynolds* (1900); *J. M. W. Turner* (1901); *Sir Henry Raeburn* (1901) and *Art in the British Isles* (1909);

besides *Lives of Alfred Stevens, Peter de Wint, Gainsborough and Velasquez*. He was also co-editor of Bryan's *Dictionary of Painters*. He died in London Aug. 8 1918.

**ARMY** (see 2.592).—In different sections which follow under this heading, the later history and organization of some of the powerful national armies which figured prominently in the World War are dealt with. In the articles on countries details of the post-war organization are given, and the object here is to explain the functioning of their armies in 1914-9.

### I.—THE BRITISH ARMY

*Command and Administration.*—In 1910 the British army was commanded and administered by an Army Council, a system first instituted on Feb. 6 1904. The constitution of this council was: the Secretary of State for War; the chief of the general staff (whose designation was altered in 1909 to that of "chief of the Imperial general staff"); the adjutant-general to the forces; the quartermaster-general to the forces; the master-general of the ordnance; the finance member of the Council; the civil member of the Council (later known—July 1916—as "under-secretary of State for War"); and the secretary of the War Office (as secretary). Outside the headquarters staff an inspector-general of the forces was appointed, whose duties were to review generally and to report to the Army Council on the practical results of the policy of that Council; and for that purpose to inspect and report upon the training and efficiency of all troops, on the condition of fortifications and defences and generally on the readiness and fitness of the army for war. On Aug. 2 1910 the duties of the inspector-general of the forces were divided between the inspector-general of the home forces and the inspector-general of the overseas forces (the general officer commanding-in-chief in the Mediterranean). Both appointments lapsed on the outbreak of war in 1914.

The above constitution of the Army Council continued until the outbreak of the war, after which it was varied from time to time by the following additions: the deputy chief of the Imperial general staff (Dec. 1915); the director-general of military aeronautics (Feb. 1916); the director-general of movements and railways (Feb. 1917); the surveyor-general of supply (May 1917). The director-general of military aeronautics, who was first appointed in 1913 directly under the Secretary of State, ceased to be a member on the institution of the Air Council on Dec. 21 1917. Another variation took place on Feb. 27 1918, when the permanent British military representative, British section, Supreme War Council of the Allied Governments, was added; but he again was removed on April 20 of the same year.

The assignment of duties varied somewhat under the successive Orders in Council, but the general principles were as follows: Duties in relation to operations were allotted to the chief of the general staff; those relating to organization, disposition, personnel, armament and maintenance, to the adjutant-general, quartermaster-general and master-general of the ordnance; those relating to the Territorial Force Associations, the Volunteer Force and War Department lands, to the civil member; finance duties, to the finance member; transportation, to the director-general of movements and railways; business relating to the commercial administration of army supplies, not under the control of the Ministry of Munitions, to the surveyor-general of supply.

In more detail the responsibilities of the military members of Council were as follows: The general staff dealt with the preparations for and the execution of military operations, including the estimates of forces required, the organization and establishments of these forces from the broader aspect, also with all matters connected with military intelligence and questions of staff duties, including training and education. The adjutant-general was responsible for all questions relating to personnel (except that of the Army Service Corps, Army Ordnance Corps, Army Pay Corps and Chaplains Department) and discipline, for organization, establishments in detail, mobilization, recruiting, discharges and for the control of the Army Medical Service. The quartermaster-general was responsible for supplies, transport, clothing and equipment (including personnel and organization), for movements, quartering, remounts and the Army Veterinary Service. The master-general of the

ordnance was responsible for armaments, the manufacture of ammunition and for the Fortifications and Works Department.

In the organization of the armies in the field a partitioning of responsibilities similar to that arranged among military members of the Council was adhered to though some modification was necessary because the staff in the field was organized under three principal staff officers only:—The chief of the general staff, the adjutant-general, and the quartermaster-general; the master-general of the ordnance had no direct representation at G.H.Q. The major portion of the latter's duties in the field came under the control of the quartermaster-general, while the engineer-in-chief (a special field appointment) absorbed such of the duties of the director of fortifications and works as were required in the field. The quartermaster-general in the field controlled the paymaster-in-chief, and had the assistance of the financial adviser to the commander-in-chief, while the adjutant-general in the field controlled the Chaplains Department. It is noteworthy that it was not until April 1917 that the director-general of movements and railways was appointed to the Army Council, involving the removal of these duties from the quartermaster-general's control, a similar change was effected simultaneously in the field armies by the addition to the commander-in-chief's staff of an inspector-general of transportation, independent of the quartermaster-general. Similarly, the appointment of a surveyor-general of supply, anticipated by that of an additional civil member of Council to supervise army contracts in Dec. 1914, took, for coördination purposes, from the control of the quartermaster-general, the master-general of the ordnance and the finance member, such functions as related to the commercial side of the business of supplying the army.

The military departments concerned retained responsibility for design, specification and testing as well as for research and experimental work. The director of army contracts was brought under the surveyor-general of supply, and later there was added the directorate of army priority which absorbed the branch known as "Allies' Munitions Requirements" from the Department of the Civil Member. A director of wool textile production was added in Dec. 1917, and in Feb. 1918 the Army Salvage Branch developed and was placed jointly under the quartermaster-general and the surveyor-general of supply. The only other appointment of interest is that of the military secretary. This office has always existed, at one time it was under the direct control of the commander-in-chief and later under the Secretary of State for War. The exact functions have varied from time to time. Broadly speaking, the branch, both in the War Office and at G.H.Q. in the field, dealt with appointments and promotions of officers, and with honours and rewards for all ranks. Other changes which removed certain duties and responsibilities from the Army Council to newly formed ministries were effected by the creation of the Ministry of Munitions (June 1915), the Ministry of Pensions (Feb. 1917), and the Ministry of National Service (Oct. 1917). Thus, on its formation, the Ministry of Munitions took over responsibility for the supply of munitions, leaving the question of design to the War Office. About June 1915, however, the Ministry of Munitions became responsible for design in so far as part of chemical warfare and trench warfare was concerned, and in the following Oct. it took over responsibility for design in other directions. The director of artillery became indeed nothing more than the military representative of the War Office and the Front, responsible for making demands—affecting both design and supply—on the Ministry of Munitions.

In the original design for the British armies in the field, the inspector-general of communications held the status of a commander but by a process of gradual absorption he eventually passed, except for defence duties on the lines of communication, under the command of the adjutant-general (for reinforcements and casualties) and the quartermaster-general (for supply and maintenance).

It is unnecessary to describe in detail the organization of army headquarters in India, but it should be said that, so far as Indian army troops co-operating with British troops in the various theatres were concerned, the system of command and administration was generally similar to that described above, the chief difference being that in India the medical, ordnance and military works branches were each of them independent branches, working directly under the commander-in-chief. As for the dominions, Crown colonies and protectorates other than India, it had been unanimously agreed at the Imperial Conference of 1909 that the organization of all the forces of the Empire should be assimilated as far as possible. In Canada there existed a permanent militia and an active militia, each serving on a three-year term of engagement. They were organized as 7 mounted brigades, 10 brigades of field artillery, 23 infantry brigades, with the necessary ancillary services. In Australia a Military Training Act had been passed, rendering liable for service

in time of emergency all males between the ages of 18 and 60, and imposing compulsory training in the militia on all males between the ages of 18 and 26. The permanent force comprised only three field batteries, 13 companies of garrison artillery, with certain engineers and a nucleus of departmental services. This force, serving on a five-year engagement, and the militia forces, serving on a three-year term, were organized in both mounted and infantry brigades with establishments similar to those of the British army. In 1913-14 the militia comprised 23 mounted regiments, 22 batteries of field artillery and 50 battalions of infantry, with proportionate ancillary services. In New Zealand all males between the ages of 17 and 55 were liable for service in time of war, those between 18 and 25 undergoing training and those between 25 and 30 passing to the reserve. The permanent force (sufficient only for instructional purposes) serving on an eight-year engagement, and the territorial force, on a seven-year engagement, consisted of 12 mounted regiments, 9 batteries of field artillery, 9 batteries of garrison artillery and 16 battalions of infantry with the necessary ancillary services. In the Union of South Africa the permanent force on a five-year engagement consisted of five mounted regiments and five batteries of artillery. There were also a small coast-defence force and an active citizen force, serving on a four-year engagement, comprising nine mounted regiments, four dismounted regiments, three batteries of field artillery, 12 battalions of infantry and the necessary ancillary services. No other colony or protectorate maintained a force of any appreciable size, but all had some force of armed police or volunteers in some sort of military organization. In certain of the protectorates, such as East Africa, Nyassaland, Somaliland, Uganda, Gambia, Gold Coast, Nigeria and Sierra Leone, permanent coloured troops, officered by officers seconded from the regular army, were maintained for local service. In all the dominion forces the armament was in the main identical with that of the British army, the only important exception being that Canada in lieu of the Lee-Enfield .303 rifle had the Ross of the same calibre. The latter was discarded early in the war.

*Forces Available.*—Until the end of the 19th century the British forces, always limited by the expense entailed, were maintained for the following purposes: (a) Garrisons of trained troops for the outlying colonies and protectorates (including India); (b) a force available for the prosecution of punitive expeditions, or for the maintenance of order in those colonies and protectorates or on their frontiers; (c) the first-line defence of the United Kingdom in the event of invasion. The South African War, however, of 1899-1902 proved such a severe strain on home military resources that assistance offered by the self-governing dominions was gratefully accepted; and the rendering of this assistance marks a definite and important step forward in the military organization of the Empire as a whole. Owing to the trend of European politics at the beginning of the 20th century, the purposes for which the military forces were maintained underwent a definite change, and the organization—still limited by the costliness of a purely voluntary system of service—was subjected to a series of reforms based on the following possible requirements: (a) a small striking force capable of taking the field in Europe at short notice; (b) garrisons for colonies and protectorates (including India) and reinforcements for the prosecution of punitive and other campaigns in connexion therewith, (c) the defence of the United Kingdom against invasion during the possible absence of the striking force referred to above. This change in policy, due to the possibility of intervention in a European war, involved the absorption in the striking force of the whole of the regular forces serving at home, and thus the provision of additional organized forces adequate for defence against invasion became a vital necessity.

During the years 1910 to 1914, therefore, military effort was concentrated on the organization of this small striking force of regulars (which received the title of "Expeditionary Force") and of the Home Defence Force of territorial troops. The focussing, at the outbreak of war, of the whole regular military energy and experience on a small expeditionary force, and the consequent neglect of preparations to make use of the untrained masses of the male population capable of bearing arms, led, however, to a temporary paralysis of the powers of expansion. The regular expeditionary force was permanently organized in its field formations of divisions, and up to the outbreak of the World War no higher formations, such as army corps and armies, had been definitely organized, although the staffs and headquarters units for a general headquarters and two armies (or

army corps) were detailed to be formed on mobilisation. In addition the lines-of-communication troops provided were calculated to a minimum, which in practice soon proved inadequate. As regards personnel, the peace establishments of the units composing the force were, in the interests of financial economy, based rather upon the numbers required annually to provide the drafts necessary to maintain the strengths of the garrisons in colonies and protectorates than upon the requirements of the Expeditionary Force when it should take the field.

As must be the case with any army raised and maintained upon a voluntary basis and paid as economically as possible, a constant and large percentage of the individuals included in the home establishments were "immature," either because their training had only lately begun or because they had been accepted when still youths with a view to their gradual development; so that in order to put this Expeditionary Force in the field it was always necessary that there should exist reserves not only sufficient to make up the difference between peace and war establishments, but also sufficient to replace the "immatures" included in the peace establishments and to provide replacements for early casualties up to 10% of the force. But, in spite of continued and varied campaigning, the British army had never been called upon to replace any great number of casualties; and therefore the necessity for providing numerous trained reserves in excess of those required for first mobilization, although foreseen, was not sufficiently realized by the country as a whole.

The actual organization maintained, then, during this period was as follows: (a) The regular army at home, organized to place in the field, at very short notice, one cavalry division (four to five brigades), six infantry divisions (with a minimum of lines-of-communication troops), and certain coast-defence troops (for home defence). To meet the deficiencies in personnel there existed: (b) the regular reserve, composed of men who had been fully trained by service in the regular forces; (c) the special reserve (known as "militia" until 1908), organized in units and composed of men who had merely received a recruit's training and subsequent annual trainings of 27 days in their special reserve unit, and certain skilled tradesmen who did not require and did not receive a military training (these were not organized in units). The special reserve units proper formed the infantry of the coast-defence garrisons. It was further proposed that certain of these special reserve units (known as "extra-special reserve units") should be used as units (not draft-finding) either on the lines of communication of the Expeditionary Force or to relieve regular units on foreign service in order that they might join the Expeditionary Force, should it be so desired. (d) The Territorial Force, organized in 14 mounted brigades, 14 infantry divisions and certain coast-defence troops. Being designed for home defence only, the peace establishment of the Territorial Force was intended to be that at which it would take up its defence duties in war. And not only was the strength of the Territorial Force seriously deficient, but much of the personnel were inadequately trained, and, moreover, included a large percentage of men who were too old or too young or physically unfit for active campaigning. The Territorial Force Reserve was so weak as to be negligible (661 officers and 1,422 other ranks on July 1 1914).

Other forces which existed or came into being during the years 1910 to 1914—which may be termed the preparatory period for the World War—were, in addition to the Territorial Force Reserve: (a) the Technical Reserve; (b) the Veteran Reserve. When these forces were first formed in 1910 they were intended to be part of the Territorial Force Reserve, but in 1911 they were reorganized, and the Territorial Force Reserve was relegated to its own force, the other two reserves becoming distinct formations, the Veteran Reserve being renamed the "National Reserve." Neither of those forces had any definite liability for service unless undertaken by individual members in some other capacity. The functions of the Technical Reserve were to supply expert and skilled workers to assist the national forces in time of national emergency. For this purpose there were registered a number of owner-drivers of motor vehicles, a few of whom were eventually attached to the Expeditionary Force, the larger number, however, being utilized at home. The "Voluntary Aid Detachment" scheme also was instituted as part of this reserve, and in accordance with the Geneva Convention.

Originally designed to supply the personnel for "casualty clearing stations" it was finally used for the purpose of supplying personnel (almost entirely female) for military hospitals at home and overseas, each individual taking service on a personal engagement. The organization also provided and maintained a considerable number of hospitals and convalescent establishments at home.

**Training of Youths.**—Cadet units had been in existence for many years as a part of the old volunteer system, and were broadly divided into two classes, those raised and maintained by universities and schools, and those raised and maintained locally at the expense of individuals. On the formation of the Territorial Force the former class were formed into Officers' Training Corps, and in 1908 were removed from the jurisdiction of the Territorial Force Associations and came directly under the War Office. The latter units, however, were taken over by the Territorial Force Associations. The Officers' Training Corps existed primarily to provide officers for the special reserve and the Territorial Force; they were divided into senior and junior divisions by ages, the former being practically confined to the universities. Members of these corps could obtain a first certificate in either division, but the second, and qualifying, certificate could only be obtained in the senior division. The number of O.T.C. contingents in 1910 was 171 and in 1913, 182, but the numbers composing the units had increased in 1913 to 25,208. That efficiency was also growing is shown by the fact that, in 1910, 2,665 certificates were obtained, and in 1913, 8,303—the attendances at Annual Camp in each year exceeding 10,000. In 1910 there were 340 officers commissioned direct from these Officers' Training Corps, and in 1913, 2,096.

During the war period the Officers' Training Corps were continued, and considerable use was made of their personnel in supplying the deficiency of instructors for the formation of the new armies and also in meeting the grave shortage of junior officers throughout the regulars, territorials and new armies. The normal work of the corps—more especially of the senior division in granting certificates and supplying officers for the Territorial Force and special reserve—continued throughout 1915; but at the end of that year those members who attained 18 years of age were called upon to be attested as privates, and were then immediately passed to the reserve. They were, however, continued as members of their O.T.C. until the age of 19, when they were summoned to the Colours. This continuation of their training enabled them to be rapidly brought forward for commissions, if duly recommended by their O.T.C.

The cadet units provided for the training of boys with a view to their eventually joining the ranks of the Territorial Force, and for this purpose there was a recognized affiliation between the cadet unit and the appropriate Territorial Force unit. In 1910 there were 39 such cadet units, comprising 53 companies, rising gradually to 258 units, comprising 848 companies, in 1914. During the war a very large increase took place, there being in 1915 312 units, comprising 1,007 companies, with a total strength of 41,108, which in 1919 had risen to 890 units of 2,464 companies, with a total strength of 102,500 cadets. Though by no means an Officers' Training Corps, the 26th Batt. of the London Regt. (Artists' Rifles) was in Dec. 1914 selected by the commander-in-chief to act as an officers' training battalion for the armies in France; it was withdrawn to the neighbourhood of general headquarters, and to it were attached for training all candidates for commissions from the ranks of the Territorial Force units in the field.

During 1916 the deficiency in officers became even more acute, and early in that year a cadet school was established in France at which N.C.O.'s and men selected from units actually in the field were trained with a view to their obtaining temporary commissions. Simultaneously the Army Council decided that in future—except in certain technical branches—no temporary special reserve or Territorial Force commissions would be granted to any candidate who had not passed through the ranks of a cadet school (latterly designated "cadet battalion") unless he had previous military experience as an officer. This necessitated the formation at home of a number of cadet battalions specially designed to prepare candidates for commissions. They must not be confused with the Officers' Training Corps of the cadet units normally existing in peace; in fact, members of both senior and junior divisions of the Officers' Training Corps were compelled to pass through these new cadet battalions before being considered for commissions.

**Organization.**—Certain reorganizations in the regular army itself took place immediately prior to 1914. The system of communication was greatly improved by the formation of signal;

companies, Royal Engineers (telegraph, telephone, visual and despatch-riding). One such company was allotted to each division, the headquarters section being with divisional headquarters, and a section with each infantry or cavalry brigade headquarters, units maintaining their own signallers for internal communication. In the field artillery 2 howitzer brigades and 6 divisional ammunition columns were added, the result being that each of the 6 Expeditionary Force divisions was provided with a complete howitzer brigade of 3 batteries, in place of the brigade of 2 batteries which had hitherto existed. In consequence of these additions, an increased number of army reservists were required for mobilization, and to provide them a certain number of recruits for field artillery were taken for a short period of Colour service in order that they might be rapidly trained and passed to the reserve. In this way it was possible to reduce the number of special reservists of the field artillery, and the training brigades hitherto maintained for these special reservists became available to form the divisional ammunition columns on mobilization. The number of field-artillery depots was increased from 4 to 6. The infantry organization was also altered from 8 to 4 companies per battalion. This reorganization had not taken place in the Territorial Force when mobilization occurred, but was then introduced. A complete revision of the system of supply and transport in the field was also made. The divisional train system (organized in 4 companies, each composed of a technical headquarters and the baggage and supply wagons of units, manned by Army Service Corps drivers) was introduced, and the chain of supply to railhead was completed by the introduction of a mechanical transport supply column of 3-ton lorries for each division. This unit, plying between railhead and the refilling point, daily refilled the supply wagons of the train. The cavalry division did not form a train but was served by two mechanical transport supply columns of 30-cwt. lorries delivering on alternate days. The supply of ammunition was organized in a similar manner, the divisional ammunition column (horsed) refilled units and was itself refilled from railhead by a mechanical transport ammunition park (one per division) (For the *FLYING CORPS*, see the article under that heading.)

In the organization adopted for war the division was designed to be the tactical and administrative unit, self-contained in that it was composed of all arms (except the Flying Corps) and was provided with all the ancillary services required for its maintenance in the field. This system obtained throughout the British armies during the war, the divisions as self-contained units being allotted to army corps as occasion required, and these in turn to armies; the only deviation was in the case of the Australian and the Canadian army corps, in which the corps itself, once formed, remained intact and in certain respects became the "unit of administration."

The division in detail consisted of: headquarters (including the commander and staff, the commanders of artillery and engineer troops and the directors of medical, veterinary and ordnance services), 3 infantry brigades—each of 4 battalions, reduced in the winter of 1917-8 to 3 owing to shortage of personnel, 4 artillery brigades—each of three 6-gun batteries (three brigades were 18-pounder guns and one was 4.5-in howitzers), one heavy battery and ammunition column—four 60-pounder guns, horse-drawn; one divisional ammunition column (carrying ammunition for all arms), 3 field ambulances—each comprising bearer and tent divisions, 2 field companies Royal Engineers (a third added later); one signal company R.E. (sections distributed to headquarters of divisions and infantry brigades), the divisional train (carrying baggage and supplies and executing all supply arrangements between refilling points and the troops themselves); one mobile veterinary section; one cavalry squadron (withdrawn almost immediately to reinforce the cavalry corps). Thus it had a strength (excluding details at the base at the rate of 10% of strength) of 585 officers, 17,488 other ranks, 5,592 horses, 76 guns, 24 machine-guns.

The organization of a cavalry division followed the same lines, but comprised 4 brigades each of 3 regiments, in place of 3

brigades each of 4 battalions in the infantry division. The strength (excluding details at the base at the rate of 10% of strength) was 439 officers, 8,830 other ranks, 9,815 horses, 24 guns (13-pounder), 24 machine-guns.

*Administration of Personnel.*—The record of services of all personnel (except officers) together with necessary personal details were kept track of through the "record offices." In these offices were filed the original attestation forms, on which all "casualties" affecting the rank and file (e.g. promotion, postings, transfers, alteration of original terms of service, wounds, rewards, punishments, and details of marriage, children and next-of-kin) were entered on receipt of the notification of the "casualty" from the unit concerned. This system continued in war as in peace. All such notifications in war, however, passed through the 3rd echelon of general headquarters of the theatre and were also entered on a special war army form which followed the individual throughout his service during the war period. By this means general headquarters could be kept informed of the state of their forces in bulk or detail and the War Office of the general strength of the armies. The careers of officers were followed in a somewhat similar manner, but certain War Office branches acted as record offices.

Payments to officers were made through agents (bankers), and special army cheques made out by an officer could be cashed within defined limits by field cashiers accompanying the troops. Payments to men were reported on "acquittance rolls" and entered in the personal pay book carried by every man. These payments—together with credits, counter-charges and claims received from any source or resulting from casualties reported to record offices—were brought to account by the regimental paymaster at home in charge of the accounts of the men affiliated to each record office. This system, prepared shortly before the outbreak of war and first entered therein, obtained for all theatres except India and Mesopotamia, and proved very successful—the maximum personnel engaged at any time being 1,912 directing staff (of whom 250 were females) and 44,676 subordinates (of whom 30,000 were females).

*Mobilization.*—Preparations for mobilization had followed most careful and detailed consideration during the years immediately preceding the war; and it may be truly said, in respect of the Expeditionary Force, that when mobilization was ordered in Aug. 1914 everything was ready "down to the last gaiter button." These mobilization preparations were confined entirely to that Expeditionary Force; the embodiment of the special reserve and the Territorial Force being merely a calling-up of existing personnel and not in any sense a "mobilization." The stages in the prepared plan of mobilization were minutely followed, and comprised, first, the initiation of what was termed the "precautionary period," followed almost at once by that termed "general mobilization." The "precautionary period" scheme was based on the necessity for defending the United Kingdom against the possibility of invasion or raids—a primary danger in the case of an island power. For this purpose the rôle of the navy was of first importance, and defence was required for all harbours and dockyards called into use. The plan was briefly that all standing defences (artillery and its ancillary services of electric lights, etc.) should be immediately placed on a war footing—the personnel being completed by regular reservists who, on the first day of mobilization, joined the units detailed for standing defence duties. These units again were augmented by units of the special reserve and Territorial Force accustomed to train annually at the defences for which they were intended and which they actually manned at the outset of the "precautionary period." The mobile force associated with these defences was in the first instance formed of infantry and artillery units composing their peace garrisons, reinforced temporarily in many cases by detachments of serving personnel from units stationed farther inland and actually mobilizing. On the embodiment of the Territorial Force, certain of its units proceeded, according to programme, to their coast defences (known as their "war stations"), thus replacing units of the regular army temporarily forming mobile garrisons but actually destined for the Expeditionary Force; these Territorial Force units were sufficient not only to form the garrisons, but also to furnish small mobile columns. Later, certain of these units—chiefly those detailed for fixed defences—were in turn relieved by special reserve infantry units, who proceeded to their allotted coast defences or "war stations" after embodiment at depots, where they had shed their Expeditionary Force

personnel and absorbed any surplus regular reservists and sick and immature men of the mobilized regular units. In addition to the manning of the coast defences, certain vulnerable points—e.g. possible landing-places for small raiding-parties, cable landing stations, wireless receiving stations, vital railway bridges—required watching or protection at the inception of the precautionary period. This was undertaken as an additional obligation by the special service sections of the Territorial Force, each being allotted a particular war station. Those units of the Territorial Force not absorbed either at once or after relief by the special reserve units in coast defences, were assembled for training in their infantry divisions and mounted brigades; and preparations were completed for their rapid conveyance to any threatened point.

In actual fact a slight variation from the original scheme was made for a few days in respect of the disposition of the 4th Regular Division of the Expeditionary Force. This division, whose normal peace stations were in Woolwich, Shorncliffe, Dover, Chatham and Colchester, was ordered on the third day of mobilization to send small forces of infantry and artillery to Norfolk, Yorkshire and Edinburgh. Its headquarters were later moved to Bury St. Edmunds, and took over for some days the command of the east coast (excluding coast defences), until a Territorial mounted division was sufficiently organized to release the 4th Division for the Expeditionary Force in France. Similarly, the 6th Division from Ireland was brought over to England and assembled as a support to the Territorial formations guarding the east coast. This division, an integral part of the Expeditionary Force, was retained at home for this defensive purpose until the beginning of Sept. and only then followed the Expeditionary Force, joining it on the Aisne. General mobilization was, therefore, really confined to the regular units comprising the Expeditionary Force.

To deal first with personnel. As a constant preparation for mobilization, each unit during peace compiled twice yearly a mobilization form, showing the personnel actually available with the unit, less those required for duty elsewhere and those immature or insufficiently trained for the field. This form was passed to the record office concerned, which, after stating the number of reservists detailed for the unit and its first reinforcements (which invariably accompany it overseas), and any deficiency or surplus of reservists, passed on the form to the War Office for investigation and information. The only action taken in the War Office was to detail the requisite number of officers from the reserve of officers and special reserve. The proclamation of mobilization and simultaneous issue of posters and individual notices summoned all reservists to rejoin the Colours—those of cavalry and artillery to allotted depots; those of infantry to regimental depots, where they were clothed, armed, equipped and dispatched as required to units, the residue remaining at depots for incorporation in special reserve units in course of embodiment. Those of other arms rejoined their units direct, there to be clothed, armed and equipped; any surplus or deficiency being adjusted by their corps depots, where the surplus unallotted reservists rejoined. As regards *mâtriel*, each unit of the Regular Expeditionary Force (with the exception of certain mechanical transport units of the Army Service Corps) possessed the mobilization vehicles, arms and equipment required to pass from peace to war scale; and it was merely a question of issue and taking into use. As regards horses, the whole system had undergone revision only just in time for actual mobilization. This system was that commands made a classified census of suitable horses available among the civil population. Any surplus over and above that required by units mobilizing in one command was re-allotted by the War Office to meet deficiencies in other commands—e.g. the Aldershot command, which has practically no territorial area, obtained most of its horses from the London district, which mobilized very few troops. The system involved sending for the horses, but the loyal coöperation of inhabitants in voluntarily bringing their horses to named centres to a certain extent overcame this defect. Certain large firms had for some years received annual subsidies under a contract to provide on emergency a given number of horses of specified classes suited to military requirements.

**The War Period.**—Owing to the special conditions of warfare which prevailed from 1914 onwards, to the progress of inventions, and to the variety of theatres in which operations took place, the standard organization of the original Expeditionary Force proved inadequate to meet the various requirements. It is, however, noteworthy that the structure of the infantry divi-

sion—the main basis of organization—remained substantially intact, though the strengths and the proportions of arms and services underwent modification, according to changing conditions and the special needs of certain theatres. Thus, to the divisional organization were added, for example, an employment company and a salvage section.

**Royal Engineers.**—In the later stages of the war the need—in connexion with artillery-ranging—for more accurate ground surveying than was afforded by the field-maps became evident. The three field survey companies—employed prior to mobilization by the Board of Agriculture and Fisheries on the continuous survey of the United Kingdom—were therefore expanded into field survey battalions. France—receiving one per army and other theatres a due proportion. These included specialist sections termed topographical, map, observation, sound-ranging and meteorological.

When mine warfare was added to trench warfare above ground, 25 special "tunnelling companies," recruited from coal-miners, were formed, each with an establishment of 14 officers and 307 other ranks. This was later raised, in the case of all but 5 companies, by 4 officers and 223 other ranks per company, by the attachment of infantry working parties.

Artisan works companies to the number of five were formed in France for the construction of hutting and other engineering work. Eleven forestry units, for the purpose of obtaining timber in France, were raised, and in addition a considerable number formed in Canada were employed in France, Scotland and Wales. Seven army tramway and foreway companies were formed in France to construct, maintain and operate trench tramways and light railways, and these eventually became transportation (R.E.) units. A "special works" unit (Camouflage Park) was formed in 1916 and operated throughout the armies. A small inundation section was formed in France in 1918.

**Chemical Warfare.**—After the German gas attack at Ypres in April 1915 a start was at once made to select, organize and train the personnel who were to be concerned with the use of this new lethal weapon. The first special company of the Royal Engineers was formed for the purpose in July 1915, and numbered 186, and three other companies were in existence by Sept. of that year, taking part in the battle of Loos. Rapid progress continued; during the winter 1915-6 the 4-in. Stokes mortar and an improved flame-thrower were developed, and in Oct. the special companies were expanded into a special brigade R.E., which was composed of a special (cylinder) company R.E., with an establishment of 8 officers and 250 other ranks, a special (mortar) company R.E., of 18 officers and 310 other ranks, and special sections R.E. (for flame-throwers) which, however, were never fully equipped or up to strength, the use of this weapon being soon abandoned. During 1917 this organization was again revised, and each of the five armies then in existence in France was provided with a headquarters special company R.E.—the various technical companies being allotted as required by the tactical situation.

The above was the organization for offensive action. Defensive measures against gas were first organized by the director-general of the army medical services; and in June and July of 1915 specialist officers were appointed to the headquarters of each army, where anti-gas schools were established. These officers were at first called "chemical officers," then "gas officers," and finally "chemical advisers." In March 1916 the defensive measures were taken over by the director of gas services for coördination with the offensive measures, and gas officers were appointed to all divisional headquarters where anti-gas schools were established. The special brigade R.E. also provided non-commissioned officers to infantry brigades for the purpose of checking the fitness or otherwise of the respirators and for supervising the general state of gas defence. In March 1917, chemical advisers were appointed to each corps headquarters. The gas services eventually expanded to a total of 499 officers and 6,875 other ranks.

**Royal Artillery.**—In the original Expeditionary Force the ratio of guns to infantry was approximately 6 per 1,000 rifles, but as the war progressed so did gun-power show a marked increase; and whereas in Aug. 1914 Royal Artillery personnel throughout the world totalled 92,920, by Aug. 1918 it had reached 548,780. Taken in detail the horse artillery made but slight increase, the number of batteries rising from 26 to a maximum of 28 in 1918; field artillery increased from 153 to a maximum of 722 batteries in 1915. This number, however, was subsequently reduced to just over 600 6-gun batteries by the assimilation of a certain number of 4-gun batteries. A considerable reorganization took place later when the field artillery brigades were reclassified as "divisional" and "army." In the Royal Garrison Artillery, which manned the medium and heavy guns and howitzers as well as the few mountain batteries, the number of heavy batteries rose from 12 to a maximum of 100 in 1916; siege batteries from 3 to a maximum of 425 in 1917; mountain batteries from 9 to a maximum of 17 in 1918. Anti-aircraft sections, non-existent in 1914, reached a maximum of 275 in 1918. Trench mortar batteries, first formed in 1916, reached their maximum of 142 in 1917.

**Machine-Gun Corps.**—In the autumn of 1915 the formation of the Machine-Gun Corps was decided upon. Originally consisting in

separate companies, the corps was reorganized in the winter of 1917-8 on a battalion basis. Eventually one machine-gun battalion was attached to each division, and other battalions were army troops. A battalion comprised 4 companies, and a company consisted of 4 sections each of four guns (total 64 guns). A portion of this corps eventually became the nucleus of the Tank Corps.

**Tank Corps.**—In June 1916, the heavy section of the Machine-Gun Corps in France was organized in six companies as the nucleus of the Tank Corps. Each company consisted of 4 sections, each of 6 tanks, three "male" and three "female" with one spare tank per company. The crew of a tank was one officer and seven other ranks. In Sept. of the same year expansion was decided upon. An administrative branch was to be formed in England and a fighting branch in France, consisting of 4 companies designed to become 4 battalions as the tanks became available. At the same time 2 companies were formed in England with the intention of their development into 5 battalions. By Nov. 1916, the first 4 battalions in France were grouped in 2 brigades, and in April 1917, the 3rd brigade of 2 battalions was transferred there from England. Expansion continued, and in June 1917, the title of "Tank Corps" was definitely bestowed on the corps.

In April 1918—after various vicissitudes and delays, due sometimes to difficulties of manufacture and sometimes to shortage of personnel—a portion of the corps was formed into armoured car battalions; and at the time of the Armistice plans were in hand for an establishment of 6,000 tanks in 1919. The original Tank Committee which had handled the design and manufacture of tanks was replaced early in 1918 by a Tank Board including official representatives of the Ministry of Munitions, Admiralty and War Office and individual experts, thus ensuring for the new arm a concentration of expert naval, military and industrial knowledge.

**Medical.**—On the outbreak of war steps were taken to prohibit the export of drugs and to encourage the manufacture in Great Britain of certain drugs which before the war were largely imported from Germany. Elaborate arrangements were made to meet very large demands for medical and surgical stores, and there was no lack of the essential remedies and appliances required for the treatment of the sick and wounded. The Army Medical Stores at Woolwich were expanded and depots were established throughout the country for the supply of medical stores to home hospitals. The use of certain acids, etc., for medicinal purposes was either stopped or restricted and substitutes employed so that these substances might be available for the manufacture of explosives. Stocks of quinine were commandeered to meet heavy demands, and during the early part of the malarial season of 1917 the average monthly issues of this drug were over 5½ tons. A total of 1,088,000,000 tablets of compressed drugs were supplied, and some 34,000,000 doses of various vaccines and sera were issued for the prevention and treatment of disease. Practically all the vaccines were manufactured in the laboratory of the Royal Army Medical College. An army spectacle depot was established in London for the supply of spectacles, etc., to the troops, and this depot eventually supplied all the artificial eyes and ophthalmological apparatus required. Over 350,000 pairs of spectacles and 22,386 artificial eyes were supplied, and 528 X-ray outfits of various types were issued. Splint-making shops were established in France, Egypt and Salonika, the output of which was supplemented by the supply from Great Britain to the armies in the field of 1,675,000 standard splints. Enormous quantities of surgical dressings were issued during the war, including over 108,000,000 bandages, over 87,700 m. of gauze and over 7,250 tons of cottonwool and lint. At the beginning of Aug. 1914, hospital accommodation in the United Kingdom amounted to approximately 7,000 beds, distributed in some 200 hospitals of varying sizes. On the mobilization of the Territorial Force the hospital accommodation was increased by 11,960 beds in 23 general hospitals (subsequently increased to 25) which were rapidly established in buildings which had been earmarked previously for the purpose, chiefly in university towns. The permanent military hospitals, with the 23 Territorial Force general hospitals, formed the nucleus of the war hospital accommodation in the United Kingdom. This accommodation was expanded as occasion demanded by means of hospitals organized by Voluntary Aid Detachments or private effort, by the conversion of asylums, poor-law institutions, and other large public and private buildings into temporary military hospitals, and by the allocation of beds in civil hospitals and the erection of large hatted hospitals in the various training centres. At the time of the Armistice the hospital accommodation in the United Kingdom had been expanded to a total of 364,133 beds in 2,426 hospitals and there were then 333,074 patients in these hospitals. During the period Aug. 28 1914 to July 31 1919 there were received from overseas and distributed to hospitals in the United Kingdom 2,640,650 sick and wounded. One hundred hospital ships was the maximum number ever employed, and 56 fully equipped and extemporized ambulance trains were in use at home. In 1914 the strength of the R.A.M.C. was 1,068 officers, 3,895 other ranks, 463 nursing sisters; while at the time of the Armistice its strength had risen to 13,045 officers, 131,361 other ranks, 12,769 nursing sisters, and 10,807 V.A.D.'s

**Dental Service.**—Prior to the war no dental treatment was provided for in the military organization, necessary work being carried

out by contracts with civil dental surgeons. The reduction of the standards for enlistment necessitated by the war resulted in a small organization being formed, and later the introduction of compulsory service increased the needs for dental treatment enormously, and the lack of sufficient army personnel to cope with the work at one time seriously affected the preparation of drafts for overseas. In 1918 it was calculated that 70% of slightly over 1,000,000 men at home required dental treatment before being dispatched overseas, and in July 1918 it was found necessary to call up for service all civil dental surgeons who were liable and to employ them professionally with the troops. The number of dental surgeons commissioned for professional work rose from 36 in 1915 to 850 in Nov. 1918.

**Army Service Corps** (renamed Royal Army Service Corps on Nov. 27 1918).—From 1910 until the close of the war extensive development and expansion of the Army Service Corps took place, the former being a process of slow evolution during the four years preceding the outbreak of war; the latter being necessarily rapid, and the direct result of the war itself. The strength of the corps in 1914 was 498 officers and 5,933 men; and on Armistice Day 1918 it had grown to 11,564 officers and 514,824 men. The creation of the new armies in 1914 necessitated a large and rapid increase of Army Service Corps officers; and a number of "direct" temporary commissions were granted to applicants whose experience in civil life was such as to fit them for the miscellaneous duties of the corps. The numbers obtained were so great that transfer to the fighting arms was encouraged, and later, for younger men, insisted on. The transfers totalled 1,200. Similar steps were taken as regards other ranks—82,000 being replaced in the Army Service Corps by men of other services who had become unfit for the trenches, by women by voluntary personnel. The subdivision of the duties of the Army Service Corps into animal transport, mechanical transport, and supplies continued. As regards animal transport, although the period from 1910 to 1914 showed a decrease, owing to the gradual introduction of mechanical propulsion, the expansion of animal transport during the late war was both colossal and varied, in that horses, mules, camels, donkeys, bullocks, reindeer, and dogs were all utilized to meet the divergent requirements of the various theatres. In France the Army Service Corps were responsible for the provision of personnel and the upkeep of all divisional trains, reserve parks, auxiliary horse transport companies, and horsed ambulances; and they even extended their scope in that in their advanced horse transport depots, in addition to maintaining their own formations, they held complete turn-outs for every arm of the service, technical and non-technical. In Egypt and Palestine, in addition to extensive employment of normal horse transport, 40,000 camels and 8,000 donkeys were used. In E. Africa also, as far as animal transport was possible in that theatre (owing to tsetse), in addition to the horsed transport, bullock transport and carrier transport were largely used; and in north Russia the horse and mule were largely substituted by reindeer and dogs drawing sledges. The outstanding features prior to the war, was the growth of mechanical transport, and during the war the intensive use of the internal-combustion engine in place of steam propulsion. The expansion of the mechanical-transport branch of the Army Service Corps can best be appreciated by the fact that in 1910 the total number of mechanical vehicles was approximately 175; in 1914, 248 four-wheeled vehicles and 24 motor-cycles; and in 1918, 86,837 four-wheeled vehicles and 34,865 motor-cycles. Concurrently with the large increase in vehicles, a corresponding development had of necessity to take place to ensure their maintenance. Mobile repair units were established in the field, light repair shops in the advanced areas and heavy repair shops at the bases. Advanced mechanical-transport store depots were likewise formed in the forward areas, also main mechanical transport depots at the bases. At the commencement of the war a portion of the large number of vehicles required were obtained through the medium of a subsidy scheme during peace, but, as the subsidy scheme was in its infancy, the major portion had to be obtained by impressment, the result being that the vehicles were a heterogeneous collection of condition and makes. The resources of the United Kingdom were developed to their maximum, and had of necessity to be supplemented largely through purchases abroad. Every endeavour was made to standardize the vehicles in each formation, and to eliminate non-standard makes at the earliest possible date; and the efficiency of the mechanical transport was largely due to the thoroughness with which this was carried out. In the case of supplies, prior to the war the soldier at home received a daily issue of bread and meat only, the remaining items comprising his ration being provided by means of a daily cash allowance expended under regimental arrangements. On the outbreak of war the troops both at home and abroad passed automatically to the "field" scale of rations, and the Army Service Corps was at once responsible for the provision and distribution of all the items comprised therein, as well as for many categories of medical comforts for hospital use, and, in addition, the provision of forage and petrol. As the armies increased in size, and included many different nationalities among their personnel, special treatment in diet was required, so that a remarkable diversity of commodities had to be provided; the number of these at the cessation of hostilities amounted to approximately 500 different articles, mostly perishable, as com-



pared with about 60 in 1914. During the war daily feeding strengths in all theatres reached approximately 3,400,000 men and 867,000 animals, and to meet these numbers the daily tonnage in foodstuffs was 11,000 tons, and in forage 8,000 tons. To ensure this maintenance, supplies were drawn from every quarter of the globe, a fact which—combined with the effects of submarine warfare—necessitated provision being made months ahead, so that a steady flow to the various theatres of war should continue with the minimum of interruption. Further, it was necessary to establish large bakeries, build frozen-meat stores, or increase the existing accommodation for frozen meat, and develop the local resources of each theatre to the fullest extent, with the view of economizing shipping. The Army Service Corps also undertook the manufacture of certain commodities, such as pearl barley, sausages, beef stew, tinned jam, ghee, and tinned chicken; in addition to agricultural developments for the provision of vegetables, potatoes, barley, maize and wheat. They also arranged bulk installations for petrol, and the necessary provision of tinsplating and case-boarding for canning and packing.

**Army Ordnance Services.**—In 1910, and onwards till 1914, the ordnance services of the army were carried on by a staff of 251 officers and 2,311 other ranks, reinforced by some 4,300 civilian subordinates. The "other ranks" were formed in 9 companies of widely varying strengths, and in a number of small detachments distributed throughout the army. The holding of bulk supplies of ordnance stores and clothing was restricted to Woolwich and Pimlico respectively. To these two places were consigned the stores and clothing manufactured or supplied by the Government factories or the trade, and from them distribution was made to the local ordnance depots for issue to the troops. Reserves of warlike stores and clothing for one cavalry division, one cavalry brigade and 6 infantry divisions were held in ordnance charge at Woolwich, Pimlico or elsewhere together with mobilization equipment for those units which, while non-existent in peace-time, would be required to place the Expeditionary Force on a complete war footing. As regards the organization of the ordnance services for war, this was almost exclusively confined to functions on the lines of communication. The personnel allotted to the frontal area was limited to a deputy director (and a small staff) with Expeditionary Force headquarters, a deputy-assistant director with each division, and a warrant officer with each brigade. The director of ordnance services was to be on the staff of the I.G.C. lines of communication. The personnel for lines-of-communication duties was to be found by forming ordnance companies each with an establishment of 2 officers and 164 other ranks, additional officers being allotted according to the number of companies mobilized. When, in Aug. 1914, the Expeditionary Force embarked for France, 8 of these ordnance companies with 32 additional officers accompanied it to the bases, where were also dispatched the war reserves of stores and clothing. The rapid expansion of the army in the field, and the multiplication of various expeditionary forces in widely separated parts of the globe, not only called for great increases in ordnance personnel but also revolutionized the organization of the services in the field. The main alteration lay in the recognition of the necessity for extending the principle of an ordnance officer with a division to an ordnance organization with the headquarters of each corps and army. Moreover, the immense use made of artillery throughout the campaign called into existence a number of mobile ordnance workshops, the main functions of which were to bridge the gap between the artillery front and the large workshops at the base. These field workshops, which were all mechanically propelled or drawn, were of three categories, light, medium and heavy, their nomenclature indicating the nature of the repairs to be undertaken, as also their relative degree of mobility. Though frequently "pooled" to meet any particular set of circumstances, they were organized on a scale of two light per three divisions, one medium per corps and one heavy per army. The value of these mobile shops will be the better appreciated when it is stated that but for them something like 45,000 guns and carriages would have had to be relegated some distance to the rear, if not to the base, for repair.

At the date of the Armistice there were in existence 60 of the light, 25 of the medium and 6 of the heavy variety. Other novel formations at the front included gun parks, railroad detachments, ammunition sections, and officers' clothing depots, while there were added to the normal organizations on the lines of communication institutions such as schools of instruction in ammunition, ammunition repair factories and repair depots at the bases. The effect of this wide expansion of ordnance functions and of the magnitude of the operations in the different theatres of war was to call for a very great increase in personnel, both officers and men. In the case of the former, employment was from the commencement offered to retired officers who, by taking over the work at home, released the active officers for service abroad. As soon as it was seen that many more officers would be required, a scheme was set on foot to obtain "temporary" officers from suitable professions in civil life, and to train them in ordnance duties. As for the other ranks, large numbers of pensioned warrant and non-commissioned officers of the corps offered their services. The remainder required being obtained by direct enlistment. At the date of the Armistice 2,342 officers and 38,193 other ranks were doing duty with the ordnance services, in 144 companies and other formations. The majority of this personnel was serving

overseas; the balance were at the home depots, where they formed the nucleus of a mass of civilian labour, which reached a maximum of 48,000, nearly one-half being women.

Turning to the store side of the question, the original war reserves were early exhausted, and it became necessary to evolve storage schemes in this country of far wider dimensions than were offered by the original depots at Woolwich and Pimlico. Each of these parent institutions set up subsidiary depots up and down the country, as far as possible devoting each to the storage of the class of article supplied by the trade of the particular locality. From these 'sub-depots' supplies in bulk were sent overseas direct as ordered, thus materially reducing transport and double handling. Moreover, inspection hitherto carried out only at the respective headquarters was decentralized so as to enable inspection to take place either at these sub-depots or at contractors' works. In addition to these expansions an entirely new depot of very large capacity was erected at Didcot and worked independently of Woolwich. A separate organization was called into existence to deal with the vast quantities of ammunition and explosives turned out by the national filling factories. A number of "dumps" were formed in various parts of the kingdom, and in addition an ordnance depot was attached to each factory and took over its daily output for dispatch as ordered. Some idea of the magnitude of the task imposed upon the ordnance services can be had when it is stated that the following quantities of the items named were dealt with:—6-inch (and larger) guns, 5,750; 60-pounder guns (and under), 21,160; machine-guns, 230,000; gun-ammunition rounds, 217,000,000; small-arm-ammunition rounds, 9,150,000,000; blankets, 49,674,773; personal equipment sets, about 6,500,000; jackets, upwards of 27,000,000; trousers, 27,000,000 pairs; pantaloons, 8,000,000 pairs; boots, 40,000,000 pairs.

**Labour.**—The density of armies—i.e. the number of men to the acre in the area of active operations—increased to a degree never imagined in previous wars; and this, with the long period of static warfare and the introduction of mechanical transport, by which alone it was possible to cope with the movement of the vast amount of ammunition, stores and supplies required, made road maintenance of paramount importance. The need for personnel to create and maintain the road communications became so acute that, in June 1915, labour battalions of navvies were formed. At first all the personnel was over military age, and 11 battalions attached to the Royal Engineers were formed; but these, together with the Army Service Corps companies which had gradually become necessary for work in the docks and stores, were all transferred *en bloc* to the Labour Corps in 1917. In this year also the importation of coloured labour, including Chinese and S. African, was introduced. When the French railways became so congested as to be on the verge of a breakdown, this Labour Corps was augmented from every possible source, and a large number of companies of prisoners-of-war were affiliated with it. The basis of organization was the company of 500 men; the total personnel actually raised for labour purposes being approximately 900,000, including 95,000 Chinese. In addition to the requirements for the theatres of operations, smaller companies, known as Agricultural Companies, composed of unfit and over-age men, were formed to assist agriculture at home.

**Expansion.**—No plan existed in 1914 for the expansion of the regular forces, beyond the automatic embodiment of the special reserve units. These were already included in the scheme for Home Defence, with the exception of certain extra-special reserve units which were earmarked for other service. The only step taken towards expansion during the mobilization period was to withdraw prior to embarkation 3 officers and 8 non-commissioned officers from each infantry unit of the Expeditionary Force. The next step was to call home regular units from overseas garrisons, relieving them by extra-special reserve units and territorial units who volunteered for the duty. These regular units on arrival from overseas were reorganized. The additional mounted brigades thus formed, with existing available mounted troops, enabled the cavalry to be reorganized as a corps of 3 divisions, each of 4 cavalry brigades. The 5 additional infantry divisions were completed as to other arms by the mobilization of artillery and engineer units existing at home surplus to the Expeditionary Force, but horse artillery and fortress engineer companies had to be used in some instances to make good deficiencies.

Lord Kitchener, on assuming control as Secretary of State for War, at once grasped the need for immediate and immense expansion, but there remained no regular army basis on which to build, and three alternative courses presented themselves: (a) To expand the special reserve, which was partially regular owing to the inclusion of the regular depot establishments; (b) to use the Territorial Force organization, which provided a framework of 14 mounted brigades and 14 infantry divisions; (c) to



create entirely new formations. The objections to the first course were that it would disorganize the maintenance organization (the special reserve) of the regular forces already engaged in the campaign, that the number of special reserve units was too small and that they consisted of practically nothing but infantry. The main objection to the second was the inadequacy of the framework upon which to construct the necessary 100 infantry divisions; duplication and reduplication of these small nuclei would eventually entail practically new formations; their duplication and reduplication for dilution by the inclusion of the untrained manhood of the country would render them immobile and temporarily disorganize them for any purpose whatsoever. Home Defence would thereby be paralyzed and the possibility of using any units already existing and organized for reinforcements would be neutralized. Lord Kitchener therefore decided to create new divisions forthwith, retaining the special reserve for its maintenance functions and simultaneously fostering the training and recruiting (and eventual duplication) of the Territorial Force in order to relieve regular army units in garrisons overseas and to supply immediate unit reinforcements to the field army; and further, as soon as the territorial divisions, not broken up for the above two purposes, were sufficiently trained, to put them into the field as complete divisions. The new divisions were to be created as armies (popularly termed Kitchener armies), each of 100,000 men; and the nucleus of the I. New Army was at once commenced by forming the unit organization of 6 divisions (numbered 9 to 14) and drafting into them the necessary personnel. The II. and III. Armies began to form in Sept. 1914 and comprised the divisions numbered 15, 17, 18, 19, 20, 21-26 and 37. The IV. Army (30th to 35th Divs.) began to form in Oct. and Nov. but never took the field in divisions, being converted in April 1915 to draft-finding duties. The V. Army (Divs. 16, 36, 38, 39, 40 and 41), begun in Dec., eventually took the divisional numbers of the IV. Army. The Territorial Force divisions used to relieve regular troops overseas were the 1st Wessex, 1st Home Counties and 2nd Wessex. These were never re-formed as divisions. Units of the W. Lancs. and 1st London Divs. used as unit reinforcements to the Expeditionary Force in France, were eventually reassembled in their divisions there. Those who took the field later as complete formations did so at first under their territorial designations but were eventually numbered so that the final divisional enumeration of the Field Army Divisions included all regular, territorial, New Army, Indian (embracing British and Indian native units) and Dominion contingents.

*Recruiting During the War.*—With the exception of a certain number of officers (who had had experience in the army and in many cases experience of minor campaigns) and of a certain number of older men whose period of army and reserve service had expired, there existed no reservoir of men who had undergone regular military training to arms, owing to the fact that the army had always been maintained by voluntary enlistment. This was a considerable handicap; but, on the other hand, the fact that a number of ex-officers and older men had had previous campaigning experience was an advantage, though, of course, they were insufficient in numbers to deal with the man-power of the nation as a whole.

Directly mobilization was ordered voluntary recruits offered themselves in such numbers that the recruiting machine was for a time paralyzed and unable to deal with the applicants. The intake, which, prior to the outbreak of war, was from 70 to 80 per day, rose immediately to 6,000 per day from Aug. 5 to 22; to 9,000 per day from Aug. 22 to 30; and by Sept. 3 it had reached 33,000 per day. On Sept. 10, owing to lack of accommodation in barracks and deficiencies in stores and equipment, the standards had to be raised considerably. This was correctly interpreted as meaning that the urgent need for men was over; and the numbers fell to 2,500 per day. On Nov. 6 the standard was again lowered, and recruiting rose to 3,000 a day.

Towards the end of the year—when it became evident that more men would be required—a parliamentary recruiting committee was formed, and a recruiting campaign was undertaken

throughout the country, resulting in an intake of some 60,000 men. In July 1915, a National Registration Act was passed, and the Local Government Board were allotted the task of supplying the particulars of all males between the ages of 18 and 41. From these, registers were compiled in various recruiting areas; and in Oct. 1915, the "Derby Scheme" or "Group System" was initiated by Lord Derby on his appointment as Director-General of Recruiting. Under this system men were to be enlisted for one day and immediately passed into the reserve with liability to be called to the Colours when required. Between Oct. 25 and the middle of Dec. 2,000,000 men were attested under this system, of whom 50% were married men; but as the Government had given a pledge that single men would be called up before married men, and it became clear that the single men of the nation had not responded, it was decided to introduce compulsory service.

The first Military Service Act received the royal assent at the end of Jan. 1916, rendering liable for military service all single men between the ages of 18 and 41; and calling to the Colours under this Act commenced on March 3. The Act was later extended to include married men, who began to be called up on June 24. Complaints were rife against the decisions of the examining medical officers; and medical boards were substituted in May 1917. This was followed by the transfer of recruiting from the military to the civil authorities and the creation of the Ministry of National Service as a civil authority for recruiting. This new ministry took over all recruiting duties for the navy, army and air force on Nov. 1 1917. A further Military Service Act was introduced in April 1918, rendering liable for military service all men between the ages of 18 and 51; but in actual practice the calling-up of the older men produced small results.

Under the authority of the War Office 2,631,313 men voluntarily enlisted between Aug. 4 1914 and the end of Feb. 1916; and from March 1 1914 to end of Oct. 1917, 1,790,381 men were called to the Colours; this gives a total of 4,421,694. Subsequently, under the authority of the Ministry of National Service, from Nov. 1 1917 to the Armistice (Nov. 11 1918) 549,208 men were called to the Colours. After the Armistice enlistment again became voluntary, and the ministry enlisted 1,138 men into the regular army up to Jan. 15 1919, when recruiting was transferred to the War Office.

*Higher Formations by Theatres of War.*—The gradual expansion of the British armies in the various theatres, and variations in the strategical situation, led to changes in the organization of higher commands and to movements of the minor formations from one theatre to another. It is only necessary here to deal with the changes in organization of the higher commands, theatre by theatre.

*France (and United Kingdom).*—The first Expeditionary Force was organized as one army, sub-divided into 3 army corps. The I. and II. Army Corps and cavalry division took their place on the left of the French army in Aug. 1914, and fighting had commenced before the arrival of the 4th Div. and the III. Army Corps headquarters to which this division was allotted. These, however, took part in the operations from Le Cateau onwards, the 19th Inf. Bde. (composed of battalions originally allotted to the lines of communication) for the time being taking the place in the III. Army Corps of the 6th Div., which did not join the army in the field until the middle of September. The army was commanded by Field-Marshal Sir J. D. P. French, with Lt.-Gen. Sir A. J. Murray as chief of the general staff, Lt.-Gen. Sir C. F. N. Macready as adjutant-general, Lt.-Gen. Sir W. R. Robertson as quartermaster-general, and Maj.-Gen. Sir F. S. Robb as inspector-general of the lines of communication. The I. Army Corps was commanded by Lt.-Gen. Sir D. Haig, and was composed of the 1st and 2nd Divisions. The II. Army Corps—originally commanded by Lt.-Gen. Sir J. M. Grierson, who died in France *en route* to the position of assembly—was commanded by Gen. Sir H. L. Smith-Dorrien, and was composed of the 3rd and 5th Divisions. The III. Army Corps was commanded by Lt.-Gen. W. P. Pulteney, and was composed of the 4th and 6th Divisions. The cavalry division was commanded by Maj.-Gen. E. H. H. Allenby.

In Oct. 1914 the 7th Div. and the 3rd Cav. Div. landed at Ostend under the command of Maj.-Gen. Sir H. S. Rawlinson.

By Nov. 1914 the cavalry had been expanded to a corps of three divisions under Lt.-Gen. Allenby. Two Indian cavalry divisions composed of British and Indian units arrived shortly afterwards.

The remainder of the army was organized as follows:—I. Army Corps (Haig), II. Army Corps (Smith-Dorrien), III. Army Corps (Pulteney), IV. Army Corps (Rawlinson), Indian Army Corps (Lt.-Gen. Sir J. Wilcocks). There was shortly added the V. Army Corps (Gen. Sir H. C. O. Plumer). The Expeditionary Force had now attained dimensions which necessitated its further sub-division, and the term "Army" was introduced on Dec. 26 1914, after which the army corps were designated "Corps." General Sir Douglas Haig was appointed to command the I. Army and Gen. Sir H. Smith-Dorrien, who was shortly succeeded by Gen. Sir H. C. O. Plumer, the II. Army. Lt.-Gen. Sir W. R. Robertson became chief of the general staff in France in Jan. 1915, and Lt.-Gen. R. C. Maxwell succeeded him as quartermaster-general. The III. Army was formed in July 1915, and Gen. Sir C. C. Monro appointed to the command; he was succeeded by Gen. Sir E. H. Allenby, in Oct., on his appointment to the command-in-chief in the Dardanelles.

In Oct. 1915 the composition of the British armies was: G.H.Q. troops; Royal Flying Corps (Trenchard) in three wings; Cavalry Corps (Bingham) of three divisions; I. Army (Haig)—I. Corps (H. Gough), III. Corps (Pulteney), IV. Corps (Rawlinson), Indian Corps (C. B. Anderson); II. Army (Plumer)—II. Corps (Ferguson), V. Corps (H. D. Fanshawe), VI. Corps (Keir); III. Army (Monro, then Allenby)—two Indian cavalry divisions (Barrow and Cookson), VII. Corps (Snow), X. Corps (Morland), Canadian Corps (Alderson), XI. Corps (Haking).

On Dec. 19 1915 Gen. Sir Douglas Haig succeeded Field-Marshal Sir John French in command of the British armies in France, and Lt.-Gen. L. E. Kiggell became chief of the general staff. In Feb. 1916, Lt.-Gen. G. H. Fowke became adjutant-general. Field-Marshal Sir J. French was appointed commander-in-chief of the Home Forces.

In Dec. 1915 the reorganization of the War Office staff at home, necessitated by the enormous expansion of the British army and the increasing number of theatres of war, caused considerable changes. Lt.-Gen. Sir W. Robertson succeeded Lt.-Gen. Sir A. J. Murray, as C. I. G. S. Lt.-Gen. Sir C. F. N. Maccready succeeded Lt.-Gen. Sir H. C. Sclater as adjutant-general to the forces in Feb. 1916. Lt.-Gen. Sir J. Cowans continued as quartermaster-general to the forces—a position which he had occupied since the commencement of the war and which he held until the end. In Feb. 1916 Gen. Sir C. C. Monro took command of the I. Army in France.

In Sept. 1916 the British Expeditionary Force in France continuing its expansion was reorganized into five armies, comprising, G.H.Q. troops; Royal Flying Corps (Trenchard) in five brigades; I. Army (Monro, then Horne)—I, IV, XI Corps, totalling 10 divisions; II. Army (Plumer)—VIII, IX, I. Anzac, II. Anzac Corps, totalling 13 divisions and including 1st, 2nd, 4th and 5th Australian and 4th Canadian Divs., III. Army (Allenby)—2nd Cav. and 1st (Indian) Cav. Divs., VI, VII, XVII. Corps, totalling 1 cavalry division and 6 divisions; IV. Army (Rawlinson)—1st Cav. and 2nd (Indian) Cav. Divs., III, X, XIV, XV. Corps, totalling 2 cavalry divisions and 17 divisions (including the Guards and New Zealand Divs.); Reserve (later V) Army (Gough)—3rd Cav. Div., II, V, XIII, and Canadian Corps, totalling 1 cavalry division and 10 divisions.

In Oct. 1916 Gen. Sir C. Monro was appointed commander-in-chief in India and was succeeded in command of the I. Army by Gen. Sir H. S. Horne. In June 1917 Gen. Sir E. H. Allenby was appointed commander-in-chief in Egypt and Palestine, and was succeeded in command of the III. Army by Gen. Sir J. H. G. Byng.

In Aug. 1917 the organization of five armies still held good. The Cav. Corps had been reconstituted, and comprised the 1st, 2nd, 3rd and 5th Cav. Divs.; the Indian units of the Indian cavalry divisions having been transferred to Egypt and Palestine, and the remainder of the cavalry—reinforced by mounted yeomanry—having been reorganized into the above divisions. The I. Army (Horne), containing the I, XI, XIII, Canadian and Portuguese Corps, totalled 13 divisions—the 4 Canadian divisions being now in one corps and the 2 Portuguese divisions which had joined the Allies being organized with the British forces. The II. Army (Plumer) comprised the IX, X, I. Anzac and II. Anzac Corps, totalling 12 divisions; the 1st, 2nd and 5th Australian Divs., constituting the I. Anzac Corps and the 3rd and 4th Australian Divs., with the New Zealand Division, the II. Anzac Corps. The III. Army (Byng) comprised the III, IV, VI, VII, and XVII. Corps and the 4th Cav. Div.—totalling 1 cavalry division and 15 divisions. The IV. Army (Rawlinson) temporarily comprised only the XV. Corps of 4 divisions, and the 1st Div., not incorporated in a corps. The V. Army (Gough) comprised the II, V, VIII, XIV, XVII, and XIX. Corps.

In Nov. 1917 Gen. Sir H. Plumer was appointed to command the British troops in Italy, and Gen. Sir H. Rawlinson was transferred from the command of the IV. Army to that of the II, until within a fortnight of Gen. Plumer's return in March 1918. General Sir H. Rawlinson was, in Feb. 1918, appointed British military representative on the Supreme War Council (recently instituted) and a member of the Army Council. In March, however, he was recalled to command the V. Army in the crisis following the German offensive of March 21, and in the following month resumed command of the IV. Army. In Dec. 1917 Lt.-Gen. Sir T. E. Clarke was appointed quartermaster-general, and in Jan. 1918 Lt.-Gen. Sir H. A. Lawrence chief of the general staff in France.

In Feb. 1918 Lt.-Gen. Sir H. H. Wilson was appointed chief of the imperial general staff at the War Office, and Gen. Sir W. Robertson shortly afterwards replaced Field-Marshal Viscount French (on the latter's appointment as viceroy of Ireland) as commander-in-chief in Great Britain. In Sept. 1918 Maj.-Gen. Sir G. M. W. Macdonogh succeeded Gen. Sir C. F. N. Maccready as adjutant-general to the forces at the War Office, on the latter's appointment as chief commissioner of the metropolitan police.

In Aug. 1918 there were still five armies, the cavalry corps having been reduced to the 1st, 2nd and 3rd Divs., and the XIV. and XVIII. Corps broken up. These changes were due to the diminished personnel available. The composition of the divisions, too, had been weakened by the reduction of infantry brigades to 3 instead of 4 battalions. The Royal Flying Corps (now designated "The Royal Air Force") in France had been increased by the creation of the Independent Air Force (Trenchard), which took up positions in rear of the French and was concerned with long-distance bombing.

At the time of the Armistice on Nov. 11 1918 the order of battle comprised: G.H.Q. troops, Royal Air Force (T. M. Salmond), Headquarters Squadron and 9th Bde. (directly under G.H.Q.), with the 8th Bde. in the Independent Air Force (Trenchard); Cavalry Corps (Kavanagh) of three divisions; I. Army (Horne)—VII, VIII, XXII, and Canadian Corps, and 1st Bde., R.A.F.; II. Army (Plumer)—II, X, XV, XIX. Corps and 2nd Bde., R.A.F.; III. Army (Byng)—IV, V, VI, XVII. Corps and 3rd Bde., R.A.F.; IV. Army (Rawlinson)—IX, XIII. Australian Corps and 5th Bde., R.A.F.; V. Army (Birdwood)—I, III, XI, Portuguese Corps and 10th Bde., R.A.F.

After the conclusion of the Armistice the bulk of the armies were demobilized or transferred home, the remainder forming, with young soldier battalions from home, the army of the Rhine and the necessary clearing-up forces in France and Belgium.

*Italy.*—In Nov. 1917, in the crisis following Caporetto, British and French reinforcements were sent from France. The British troops were allotted the Montello sector of the defence of the Piave, which was the hinge linking the portion of the line facing N. in the Alps with that facing E. in the plain and covering Venice. General Sir H. Plumer, until then commanding the II. Army in France, was appointed to the independent command of the British troops in Italy. On Dec. 4 the line allotted was taken over. The troops composing the force were: XIV. Corps (Lord Cavan), 5th, 7th, 23rd, 41st and 48th Divisions. Later, when it was decided not to maintain as large a force in Italy as was originally intended, Gen. Plumer returned to France and was succeeded in command on March 10 1918 by Gen. the Earl of Cavan. Lt.-Gen. Sir J. M. Babington assumed command of the XIV. Corps. The 41st Div. returned to France in March, followed by the 5th Div. in April. In Oct. the XI. Italian Army—including the XIV. British Corps (less 48th Div.) and the XI. Italian Corps; later temporarily reinforced by the XVIII. Italian Corps—was placed under the orders of Lord Cavan for what proved to be the final offensive. The 48th Div. was temporarily attached to the XII. Italian Corps.

*Egypt.*—In Jan. 1915 the garrison of Egypt had been enlarged by the arrival of troops from England, India, Australia, and New Zealand to a total strength of 68,000. They were at that time organized as: Army Troops; Indian Expeditionary Force—consisting of the 10th and 11th Indian Divs. composed of British and Indian units; East Lancashire (Territorial) Div.; Australian and New Zealand Army Corps (Lt.-Gen. Sir W. Birdwood), comprising the 1st Australian and the New Zealand and Australian Divs. The garrison at the outbreak of war was commanded by Maj.-Gen. the Hon. J. H. Byng, who was relieved in the increased command at the end of Sept. 1914 by Lt.-Gen. Sir J. G. Maxwell. In March 1915 the expedition to the Gallipoli peninsula was launched from Egypt (which acted as lines of communication to the force), and the remainder of the troops were organized for the defence of the Suez Canal. Lt.-Gen. Sir A. J. Murray was appointed to the command in Jan. 1916 with Maj.-Gen. A. Lynden Bell as chief of the general staff, Maj.-Gen. E. A. Akham as senior administrative staff officer, and Maj.-Gen. E. A. Akham as inspector-general of communications for the whole Mediterranean. Lt.-Gen. Sir J. G. Maxwell retained the position of High Commissioner.

The forces, reinforced by the withdrawal of the Dardanelles Expeditionary Force and from France, were organized for the defence of the Suez Canal, with the XV. Corps (Horne) at Port Said, the IX. Corps (Byng) at Suez, the Anzac Corps (Godley) at Ismailia, and the VIII. Corps (Davies) in reserve. The 2nd and 4th Australian Divs. were in process of formation. The 46th Div. arrived from France but returned before being incorporated in a corps. After the abortive Turkish attack the following reductions and changes took place gradually.

In 1916 the VIII, XV, and IX. Corps H.Q. returned to France, where they were reconstituted, the 42nd Div. (Feb.), 31st, 1st and 2nd Australian (March), New Zealand (April), 2nd and 4th Australian (June) and 11th (July) Divs., proceeding to France in the months shown, and the 13th Div. to Mesopotamia in March.

In June 1917, after the first battle of Gaza, Gen. Sir E. H. Allenby replaced Lt.-Gen. Sir A. Murray in the chief command, and in July the Eastern Force was under Lt.-Gen. Sir F. W. Chet-

wode, and the desert column under Maj.-Gen. Sir H. G. Chauvel. In the early part of 1918 further reorganization became necessary, and in Aug. 1918, prior to the final offensive, the forces were organized as: C.H.O. troops; Desert Mounted Corps (Lt.-Gen. Sir H. G. Chauvel), 4th and 5th Cav. Divs., Australian and New Zealand Mounted Div., Australian Mounted Div.; XX. Army Corps (Lt.-Gen. Sir P. W. Chetwode), 10th, 53rd, 60th Divs.; XXI. Army Corps (Lt.-Gen. Sir E. S. Bullfin), 3rd (Lahore), 7th (Meerut), 54th and 75th Divs.; Palestine lines of communication; forces in Egypt—force troops (including Sollum District), Alexandria District.

**Salonika.**—The Allied forces, in anticipation of the Greek nation joining the Entente Powers, commenced operations in this theatre of war in Oct. 1915, under the command of Gen. Sarrail of the French army. In this first phase of operations (the attempted relief of Serbia, and the withdrawal to and the defence of the Salonika region), the British forces engaged were under the command of Lt.-Gen. Sir B. T. Mahon, and included the 10th, 22nd, 27th and 28th Divs. The 27th Div. was transferred to Egypt at the end of Oct. but returned to Salonika in Nov. 1915. These were followed by the 26th Div. from France in Jan. 1916. In April 1916 the British forces were organized as: Army Troops (including Royal Flying Corps and a mounted brigade); XII. Corps (Lt.-Gen. Sir H. F. M. Wilson), 22nd, 26th and 28th Divs.; XVI. Corps (Lt.-Gen. Sir G. Milne), 10th and 27th Divs.; garrisons of the islands of Mudros, Imbros, Tenedos and Thasos. Gen. Sir G. Milne assumed command of the British forces in May 1916, and Lt.-Gen. Sir C. J. Briggs took command of the XVI. Corps. The 60th Div. was transferred to Salonika from France in Jan. 1917 for the spring offensive of that year, but proceeded to Egypt in June of the same year. In Aug. 1917 the force was further reduced by the withdrawal of the 10th Div. to Egypt. Other transfers and changes of organization did not affect the major formations; but the strength of the divisions remaining was of course diminished when the brigades, as in other theatres, were reduced to four or five battalions in the spring of 1918.

These 4 divisions later formed the "Army of the Black Sea." They were gradually diminished by the course of demobilization, and as the result of events and decisions on Middle Eastern policy. During 1918 and 1919 various British forces operated in the Caucasus, Persia and Transcaucasia, and a military mission accompanied Gen. Denikin's (afterwards Gen. Wrangel's) operations in South Russia in 1919-20.

**Mesopotamia.**—Early in Feb. 1915 an Indian Expeditionary Force (known as "Force D") was dispatched from India under the command of Lt.-Gen. Sir A. A. Barrett (who was shortly succeeded by Gen. Sir J. E. Nixon). This force seized Basra as a base and advanced on Bagdad. The total strength of the force at this period was 6,717 British and 19,245 Indian combatants, 5,895 non-combatants and 11,000 animals, including camels and mules. In Jan. 1916 Lt.-Gen. Sir P. H. N. Lake succeeded to the command, and the 3rd Lahore and 7th Meerut Divs. were transferred from France. Then followed the battle of Ctesiphon, the retreat to Kut and the surrender there of the 6th Poona Div. in April 1916. The force (6th Cav. Bde., 3rd, 7th and later 13th Indian Divs.) organized to relieve Kut was commanded by Lt.-Gen. Sir F. J. Aylmer, who was shortly succeeded by Lt.-Gen. Sir G. F. Goringe. On Aug. 28 1916 Lt.-Gen. Sir Stanley Maude was appointed commander-in-chief of the force. It was now organized as: base and lines of communication; Bushire detachment; Euphrates line—15th Indian Div.; Tigris Corps (Lt.-Gen. A. S. Cobbe), comprising 6th Indian Cav. Bde., 3rd Lahore and 7th Meerut Divs., 13th and 14th Indian Divs. Shortly afterwards the Tigris Corps was reorganized as the I. Indian Corps (Cobbe), comprising 6th Indian Cav. Bde., 3rd Lahore and 7th Meerut Divs.; and the III. Indian Corps (Lt.-Gen. Sir W. R. Marshall), comprising the 13th and 14th Indian Divs. On Nov. 18 1917 Lt.-Gen. W. R. Marshall was appointed commander-in-chief owing to the death of Sir Stanley Maude. The 3rd Lahore and 7th Meerut Divs. were transferred to Egypt in April and Jan. 1918 respectively. Various reinforcements had been added to the force from time to time. By Nov. 1918 there were present an Indian cavalry div. (6th, 7th, 11th, and later 3rd Indian Cav. Bdes.); I. Indian Army Corps (Cobbe), 17th and 18th Indian Divs.; III. Indian Army Corps (Sir R. G. Egerton), 13th and 14th Indian Divs.; 15th Indian Div.; North Persian Force (Maj.-Gen. L. C. Dunsterville), 36th and 39th Indian Inf. Bdes.

**North-West Frontier of India.**—From 1914 to 1917 frequent risings took place on the N.W. frontier, followed by punitive expeditions which in many cases were of considerable strength (one or two mixed brigades and sometimes more). Three divisions were maintained as war strength on the frontier throughout the period of the World War and these divisional headquarters acted as controlling headquarters and groups of columns formed substantially by their respective divisions, though the order of battle was modified as required. The 1918 operations in Persia and in the Caspian region were carried out very largely by forces working under the orders of the 4th Quetta Div. of the Indian Army.

**North Russia.**—Operations in this theatre took the form, initially, of occupying Kela and various points along the Murman railway and adjacent regions in the spring and summer of 1918, in order to

prevent the Germans and the Finns from doing so. The Allied forces were small, and were to form a nucleus for an army to be created from Russian and Czechoslovak sources. In Aug. 1918 operations extended to Archangel and to the Archangel-Vologda railway by another force. This too, though larger than that on the Murman line (numbering some 14,000 organized troops), was meant chiefly as a nucleus upon which a Russian army could be built up for operations against the Soviet Government. In May 1919 two reinforcing brigades, specially formed, were sent to Archangel, and somewhat later a small additional force was dispatched. In the spring of 1919 it had been decided to evacuate both North Russian theatres of operations, and Gen. Lord Rawlinson was sent as commander-in-chief to coördinate the two operations of withdrawal. The evacuation was successfully completed on Sept. 27 for Archangel and on Oct. 12 for Murmansk.

**Other Theatres.**—It is unnecessary here to deal in detail with the organization of the British forces in other theatres of war. Under DARDANELLES, EAST AFRICA, and similar headings, the facts are given elsewhere. Some idea of the variety and complexity of the tasks which British and British Dominion military organization had to cope with in the years 1914-20 is afforded by the fact that the subsidiary theatres included Cameroon, Togoland, German South-West Africa, Tsingtau (China), South Russia, the Caucasus, North and South Persia, Aden, the Gulf of Oman, Baluchistan, Burma, Samoa, and New Guinea.

**Statistics.**—In Aug. 1914 the total strength of the British army, in all theatres of action, was as follows: regular army, officers 10,800, other ranks 236,632; army reserve, 145,347; special reserve, officers 2,557, other ranks 61,376; Channel Isles and militia, officers 176, other ranks 5,437; territorial force, officers 10,684, other ranks 258,993; territorial force reserve, officers 661, other ranks 1,421; Bermuda and Isle of Man volunteers, officers 18, other ranks 312—a total of 24,896 officers and 708,618 other ranks.

In Nov. 1918 the army figures showed a grand total of 193,102 officers and 4,755,242 other ranks (excluding 388,599 Indian troops). The expeditionary forces alone comprised 112,200 officers and 3,114,679 other ranks; among the officers were 93,608 British, 13,382 Colonial, 4,991 Indian native, and 217 Egyptian; and among the other ranks were 1,981,667 British, 291,018 Colonial, and 854,457 Indian native. In the United Kingdom there were 61,904 British officers, 1,321,617 British troops of other ranks, 9,270 Colonial officers and 220,353 Colonial troops of other ranks. The remainder were in India and foreign garrisons and dependent ports.

The total casualties reported up to March 14 1920 comprised: killed (including died from wounds and other causes, but not including 101,000 among the "missing" now "presumed dead"), 42,348 officers and 724,500 other ranks; wounded, 97,908 officers and 1,993,081 other ranks; and "missing," 4,211 officers and 242,772 other ranks (of these 101,000 had been "presumed dead" on lapse of time, but are not included in the figure for "killed"). (B. B.-H.)

**Demobilization.**—Practically the whole man-power of the nation had been mobilized during the years of the World War. Demobilization was not therefore an exclusively military problem. It was as much an economic and industrial one; and the reestablishment of particular industries on a peace footing would depend on the order of priority of release observed. It is, indeed, impossible, in formulating a modern scheme of demobilization, to reconcile entirely the antipathetic claims of the individual and of the State; and the War Office Army Demobilization Committee—which was representative of civil as well as military interests—decided, after considering all phases of the problem, that in the national interest a soldier's entitlement to priority of release must depend on his civil occupation rather than on the nature and length of his service with the Colours (see DEMOBILIZATION AND RESETTLEMENT). The Committee went further. They decided that two particular classes of men—called "Demobilizers" and "Pivotal Men" respectively—must be released in advance even of the period of general demobilization. To the early release of "Demobilizers"—that is, the men actually required in putting through the demobilization process—no objection was, or could be, raised; but the release of "Pivotal Men"—that is, men either of special technical or administrative capacity or belonging to "key" indus-

tries, as agriculturists and miners—met with much opposition. Many of the men of this class, of course, had been the subject of appeal after appeal to tribunals for exemption and had little military service to their credit. Why, then, it was contended, should they be released before men who had served four and five years in the army? Pivotalism indeed was called "favouritism." But it should be remembered that the maximum number of "Pivotal Men" to be released was fixed at not more than 150,000 (a figure which included the "Demobilizers" as well) and that they were granted priority solely for the purpose of assisting in the reorganization of the various industries and thereby of increasing the capacity to provide employment for the less highly qualified men. On the other hand, it is true that some men of 19 and 20 years of age, with little or no technical experience, were certified as "Pivotal" by the Ministry of Labour and given early release, while some bona fide "Pivotal Men" were not released until long after the general demobilization period had begun.

As early as January 1915 the question of demobilization had been given consideration. It was not, however, until February 1917 that a draft scheme was drawn up. This scheme, applicable to troops serving in France only, was a mere outline, but formed the basis of the detailed "Regulations" finally adopted. It provided that men should be withdrawn individually from units (in an order of priority previously determined but depending in the main on individual industrial qualification) and formed into special parties called "Dispersal Drafts." These drafts would be sent to appropriate "Dispersal Stations" in the United Kingdom and there demobilized; each draft for a particular "Dispersal Station" being, so far as possible, composed of men whose homes were in the "Dispersal Area" (the United Kingdom being, for demobilization purposes, divided into 18 special areas called "Dispersal Areas") in which the "Dispersal Station" was situated. When, by this process of individual withdrawal of personnel, a unit had been reduced to a "cadre" strength—such strength depending upon the number of men that would be required to bring home the unit's vehicles, animals and regimental equipment—it would be brought to the United Kingdom and disbanded or re-formed, as the case might be, and the remaining demobilizable personnel sent for dispersal.

The scheme did not receive War Cabinet approval until November 1917, but Cabinet sanction was taken for granted; and in March 1917 an Army Order was issued providing that the "Industrial Group" of each soldier, his particular trade or calling, and whether he was married or single, should be recorded either in his Army Book 61 (if he was serving in a theatre of war) or his Army Form B303 (if he was serving at home or in an overseas garrison). The purpose of this Order, of course, was to provide an authentic record of each soldier's pre-war occupation, which would serve as a basis in applying the industrial priority principle. But the priority which, in the national interest, ought to be granted, on demobilization, to men of particular industries and professions had also to be determined. This was a matter for the Ministry of Labour, not the War Office; and a departmental "Demobilization Priority Committee" was therefore convened for the purpose of drawing up an industrial priority schedule. A further committee was set up, for the purpose not only of securing executive co-ordination but of determining, during the demobilization period, such revised instructions on priority as might be deemed necessary on public grounds or from the state of employment in particular industries.

In December 1918 Parts I. and II. of Army Demobilization Regulations were issued and circulated under cover of Army Order 7 of 1919. These Regulations set forth every detail of the dispersal procedure. Of the actual executive machinery set up in connection with the scheme it may be said that it worked throughout with unflinching smoothness and precision, in spite of arbitrary and unexpected fluctuations in the rate of dispersal. One detail of procedure must also be specially noted. In the original scheme—of which the basic principle was priority according to individual industrial qualification—it was provided that ten per cent of each dispersal draft should consist of men who, irrespective of their civil qualifications, had served longest in the theatre of war or overseas command concerned. After the Armistice, however, the demand for a speeding-up of the rate of dispersal became so insistent that the strict order of the Regulations could not be adhered to. The hands of the military authorities were forced and many new classes of men were made eligible for early release. The result was that the promised ten per cent of long service men could not always be included in dispersal drafts; and the Field Marshal Commanding-in-Chief in France

wrote pointing this fact out and insisting that, as the original scheme had been explained to the men, it might seriously affect their discipline if it were departed from.

After the Armistice, of course, demobilization became a matter of immediate public concern, and as a General Election was pending the demand for more speedy release acquired a political significance. The initial slowness in the rate of dispersal was, to a great extent, inevitable, and was due to shortage of transport and to finely strung lines of communication in the theatres of war; but it must also be remembered that the War Cabinet order to accelerate the speed at which demobilization was proceeding was not given until December 8 1918. Certain influential critics however preferred to attribute the early delays to a malignant unwillingness of the army authorities to let the men go; and considerable unrest was aroused not only amongst the public but amongst the troops themselves. Many letters were, in fact, received in the War Office from individual soldiers complaining that their commanding officers were deliberately refraining from taking steps to effect their demobilization.

The agitation continued and the situation was verging on the critical. Difficulties with the soldiers occurred at Folkestone and elsewhere. Something had to be done to stem the flood of discontent. On January 29 1919 an Army Order was issued abolishing the principle of industrial priority and substituting that of release on grounds of age or length of service. The good effect of this order was instantaneous. Yet the new Army Order wrought no fundamental change. The principle of release by age and length of service had always been recognized and had been embodied in the original scheme. The machinery of dispersal was in no way altered; the transport problem was not solved; in short, the maximum rate at which dispersal could be carried out remained as before. Just so many men as were released under the new Army Order could have been released under the old rules. And that the demand for release was as acute as ever was proved by the statistics of letters received at the War Office. After the issue of the Army Order the weekly numbers of letters received asking for the release of particular soldiers increased rapidly—in one branch only, from 4,821 for the week ending Jan. 25 1919 to 17,506 for the week ending May 10 1919. In view of these facts, it would appear difficult to explain the sudden soothing effect of the Army Order. But indeed the reason is not far to seek. The Order was accompanied by a Royal Warrant (Army Order 54 of 1919) increasing the rates of pay of men in the army, and the increases were on a generous scale. The mere changing of the principle underlying the releases would have been ineffectual—was, indeed, unnecessary. What was needed was some unmistakable proof that the military authorities were not acting in any arbitrary or obstructive manner. The idea had got abroad that men were being deliberately retained; and the issue of the warrant, coupled with the frank statement (accompanying Army Order 55) by the Secretary of State for War, threw a very different light upon the whole matter.

The total number of men (inclusive of Royal Air Force personnel) demobilized from November 11 1918 to September 29 1920—the date for which the last official Bulletin was issued—was 195,920 officers and 3,866,668 other ranks. (E. S. H.)

## II.—THE FRENCH ARMY

Although the decree of Aug. 23 1793 brought into being the principle of the nation in arms, it was not until after the war of 1870-1 that the principle of personal service for all was established in practice (law of July 27 1872). Thenceforth no one could take the place of another. Inequalities in peace-time service, however, still existed, through the operation of the ballot and certain concessions allowed to men on account of family circumstances, or educational qualifications. In 1889 a second stage was reached. Military service in peace-time was reduced to three years, but many categories of citizens, e.g. students and supporters of families, would serve only six months. In the event of war every citizen between the ages of 20 and 45 would be called, as all having served would be able to participate in the first engagements.

By the law of March 21 1905, the inequalities in the duration of military service in peace-time disappeared. Henceforth in France military service was declared personal and equal for all in peace-time as in war. Service in peace-time, however, was reduced to two years. The reduction of the duration of service to two years, together with the decrease of the French birth-rate, placed the French army in peace-time in conspicuous inferiority by comparison with the German army on a peace footing; and in 1910 an increasing volume of opinion demanded a return to three years' service.

In 1913 the German danger was apparent to the great majority of the French people. After bitter and prolonged discussions,

personal and equal service for everybody for three years in times of peace was adopted (law of Aug. 7 1913). Thanks to this law, France, with a pop. of about 40 millions (39,601,599), was able to raise an effective force of 3,780,000 men in a period of 15 days (Aug. 1 to 15 1914) by the calling up of 2,887,000.

In 1914, the French army on a peace footing was increased to 823,251 men of whom 777,215 were metropolitan troops and 46,036 colonial. The metropolitan troops were thus classified:—775,681 *hommes de troupes* (of whom 43,486 were in Morocco), viz. 47,251 *sous-officiers*, 48,357 corporals, and 680,073 privates, and in addition 1,534 administrative employés. The colonial troops comprised 45,932 *hommes de troupes* (of whom 20,420 were in Morocco), viz. 4,756 *sous-officiers*, 3,690 corporals and 37,506 privates. Eighty-four non-commissioned officers were employed at the headquarters of the colonial army. The term *hommes de troupes* corresponds in France to that of "other ranks" in Great Britain, viz. all ranks exclusive of commissioned officers. The exclusion of officers accounts for the difference between 2,887,000+823,251 and the total of 3,780,000 shown as the strength on mobilization.

From Aug. 16 1914 to June 30 1915, a further 2,700,000 men were called up to the army. From the class 1889 to the class 1916 all men were called to the colours; this amounted to a recall of 6,444,000 men. The three years' law and the previous military laws had thus given France (1) a covering army which made her front inviolable, or at least which determined the Germans to seek to envelop a wing rather than attempt to break the front; (2) a peace army able either to absorb or to provide cadres for a considerable number of reservists and of men of the territorial army. The rapid influx of so great a number of men caused high hopes in France of a happy and rapid solution of the war, when it started in 1914. But as things turned out its only result was to enable her to await, without disaster, the coming into line of Italy on the one hand, and the formation of a great English army on the other.

In Aug. 1915, when the war had already lasted one year, it was realized in France that Lord Kitchener was right in anticipating a war of several years. He himself had undertaken to form a military organization for a duration of three years; and France, having already called up numerous classes of reservists and of young soldiers, now became less hasty in calling to the colours those who remained. Thus from Aug. 1 1914 to June 30 1915 there were mobilized 5,587,000 men, which brought the total up to 6,444,000 men; from July 1915 to Oct. 1 1915 there were mobilized only 1,440,000 men in small batches.

The enrolments made by France in the course of the war reached a total of 7,842,000 French and 475,000 N. African and colonial troops, making a grand total of 8,317,000 men.

In the course of the war losses—in killed, wounded, prisoners, deaths from sickness and sick—made the numbers vary of men mobilized in the army and outside it. The need of food supplies also made it necessary to send back a certain number of individuals and parties of agriculturists who were recalled to service from time to time and then again released to work on the land.

At the beginning of July 1915 there began the process of withdrawing from the front men capable of working in munition factories. Such men were no longer, strictly speaking, mobilized, but they remained "mobilizable," and were recalled to the front when there was no longer any fear of a shortage of munitions, or when the need of the front line became dominant, as when Clemenceau at the beginning of 1918 withdrew the young workers from the factories. The following table shows by categories variations of strength.

	Mobilized strength.	Men liable to mobilization employed in the interior.	Agricultural gangs, and agriculturists on leave.
Aug. 15 1914 . . .	3,781,000	465,000	..
July 1 1915 . . .	4,978,000	122,000	30,000
" 1 1916 . . .	4,677,000	595,000	70,000
" 1 1917 . . .	4,512,000	1,183,000	100,000
" 1 1918 . . .	4,340,000	1,374,000	45,000
Nov. 1 1918 . . .	4,143,000	1,387,000	25,000

On Aug. 15 1914 the French army at the front had reached the strength that Joffre used in the battles of the Ardennes, the Marne, and the "Race to the Sea." July 1 1915 stands for the period at which it was hoped to pierce the front in Champagne. More men were made available for the armies, and also for the work preparatory to the offensive (which was to take place in September); no heed was paid to the needs of the country, since it was hoped the war would very soon end.

The 465,000 men who had been allowed to return to the interior in Aug. 1914, for public services, for the guarding of lines of communication, and for administration, were recalled to the army in July 1915. Although there remained in the interior 122,000 men (besides 30,000 agricultural workers), these 122,000 were mobilized men in the factories, and the need for munitions and for artillery was very great. From the beginning of July 1916 the English army brought a great aid and relief to France, where exhaustion was beginning to make itself felt. The mobilized strength was beginning to fall away; it was not possible to replace the dead by calling up fresh men. Moreover, it became obvious that the conditions of the war needed munitions on an ever-increasing scale, and so the munition factories were crammed with workers.

The definitive losses sustained by the French army in the World War reached a total of 1,317,000 French and 66,000 native troops, making in all 1,383,000 dead. As shown by the following table the losses in killed were very heavy in 1914 and in 1915, heavy in 1916, relatively light in 1917, and heavy again in 1918.

	Killed, or died of wounds.	Average per month.	Percentage of monthly losses in comparison with strength.
1914	301,350	60,270	2.95 %
1915	348,850	29,070	1.09 %
1916	252,300	21,020	0.71 %
1917	163,700	13,640	0.46 %
1918	250,800	22,100	0.77 %

In 1914 a Frenchman belonging to the army had two chances of life and one of being killed; he had hardly any chance of remaining without a wound. In 1915, this man had six chances of living to one of being killed, while the chances of being or not being wounded were nearly equal (two to one and a half). It was during the year 1917 that the dangers were the least; on an average one had six times as great a chance as in 1914 of not being killed.

If one takes into account the combatants in each of the armies of which the French army was composed, one sees diminishing little by little, but in a very perceptible manner, the number of infantry and cavalry, while the strength of the engineers maintained itself without great change. But the combatant strength of the artillery and air service was augmented in number by two to one in the case of the artillery and by six to one in that of the air service.

#### Combatant Strength

Arm.	May 1 1915.	July 1 1916.	Oct. 1 1917.	Oct 1 1918.
Infantry . . . .	1,525,000	1,447,000	1,142,000	850,000
Cavalry . . . .	102,000	93,500	71,000	63,000
Artillery . . . .	395,000	495,000	522,000	601,000
Engineers . . . .	104,000	125,000	121,000	117,000
Air Service . . . .	8,000	24,000	35,000	52,000

The army evolved towards material power, the rifle lost ground to the machine-gun, but the machine-guns more and more took second place to the artillery. As for the air service, it grew to an extraordinary extent. If, taking a table of numbers, a mathematician were to establish a rising curve, he would come promptly to the conclusion that in a limited number of years there would be more men fighting in the air than on the ground. And if in fact, despite the mounting numbers of the artillery and of the air service, the infantry remained queen of battles, the queen's retinue was no longer one of men on horse-

back, but one of great masses of cannon and machine-guns moving by her side and over her head.

So far we have dealt with the strength: the examination of the losses is still more conclusive.

Losses

Arm.	1914.	1915.	1916.	1917.	1918.
Infantry . . .	283,320	323,160	221,920	134,710	182,120
Cavalry . . .	3,790	3,620	2,830	3,180	7,690
Artillery . . .	8,360	11,100	16,800	15,500	27,725
Engineers . . .	2,880	6,960	5,475	4,15	7,135
Air Service . . .	32	260	620	820	1,965

The variations in the losses of the cavalry are practically without meaning, for the cavalry fought sometimes as infantry in the trenches, sometimes on foot, at other times on horse. Still it should be noted that in 1914 as in 1918, when the cavalry had occasion to engage in open warfare, *i.e.* to work as mounted men, their losses were considerably increased. During the pursuit-battles of 1918 the losses were particularly heavy.

Whilst the strength of the artillery increased from May 1915 to Oct. 1918 in the ratio of four to six, the proportion of the losses rose in ratio eleven to twenty-seven. For the air service the strength increased in the ratio of 8 to 52, that is to say 1 to 6.5—the losses increased in the proportion of 260 to 1,965, *i.e.* 1 to 8. The queen of battles, magnificently escorted in 1918 by the gun and the aeroplane, suffered less than before; it was she, however, who still ran relatively the greatest danger. She remained queen. It is of interest also to notice that the war of movement was more murderous than trench warfare. The year 1916 was for the French army the year of Verdun and the Somme, fantastic battles when artillery projectiles fell like rain in a storm. However, this battle of a year cost far less than the six months' battle in 1914, although the strengths engaged were practically the same. In 1918 the infantry lost 182,000 men out of a strength of 850,000 men; in 1916 the proportion was 220,000 out of a strength of 1,450,000. Strong souls were and always will be needed to lead men in the battle of open warfare; and the education of an army must be directed accordingly.

**Man-Power.**—The evolution of the French army from 1910 to 1914 would not be sufficiently indicated, nor would one understand the defeats from Aug. 18–24 1914, followed by the victories of Sept. 5–12, if one were only to study a table of strengths. How could it happen, one might say, that Gen. Joffre, to whom by Aug. 15 1914 France had entrusted 3,780,000 men—not to mention the precious aid and increment of strength brought by the British and the Belgians—was beaten in the battles of the Frontiers? On the Sambre, the French army, swelled by reserve divisions attached to it, had during Aug. 22–23 a numerical equality with the troops of the German II. Army to whom they were opposed. In the Woivre the III. French Army, augmented by the reserve divisions attached to it, was equivalent in strength to the opposing V. German Army. In many places in the great battle that took place from Müllhausen to Maubeuge, German units triumphed easily over French units of the same strength. At the Marne the contrary happened.

To find the explanation of this curious paradox, it is sufficient to follow the evolution of the French army before the war, and to compare the age of the combatants who were fighting respectively in the two camps. To obtain the numbers sent to her armies France had to incorporate all the recruit classes from class 1889 (men born in 1866) to the 1916 class. The men of the classes 1889–1905 had done three years' service, or in certain cases six months only. Recalled twice for a period of 28 days, and once for a period of 13 days, the men who had remained with the colours for a short time were not in Aug. 1914 sufficiently trained to be battle-worthy. That is why the army given to Gen. d'Amade for ensuring the defence of France between the Oise and the sea was valueless. Field-Marshal French obviously could not count on it for ensuring the protection of his left flank. It was necessary to have several months of war to give any fighting value to the units of the territorial army.<sup>1</sup> The men belonging to the classes 1905–13 had uniformly served two years with the colours, and would have been able without difficulty to bear their share in battle if they had had proper cadres. But even though two years' training suffices to make an excellent soldier, one cannot in that time turn out good non-commissioned officers with the aptitude to command sufficiently well established to be recovered quickly after several years spent in civil life. As the army in times of peace had not enough cadres of N.C.O.'s and of subalterns to give suffi-

cient for the formation of reserves, those reserve formations had to acquire cohesion before being in a state fit for fighting. To command these territorial and reserve units it was necessary to draw officers from civil life or older officers from the active army. In the reserve divisions, indeed, it had been possible to place a certain number of officers of the active army. But no steps had been taken to provide any for the territorial army. The profession of a soldier, like any other, requires an apprenticeship; but officers of the reserve or territorial army in times of peace might have resigned if compelled to attend frequent trainings; and so there was nothing for it but for them to serve their apprenticeship in war—a matter of many weeks. As for the older officers of the active army, retired under the age limit, they were not sufficiently young to pass on their energy to the others. The reserve divisions in Aug. 1914, therefore, were not in a condition to be considered as combatant, for lack of good cadres and also lack of youth.

The three years' law was expected to furnish the cadres which the two years' law had failed to give; but having been voted only the year previous to the war, it was not able to produce the effect which was hoped from this point of view. The three years' law called up the 1913 class in advance. Prior to this law the men of a class were called to the colours in the month of Oct. of the following year. Thus, under the régime of the two years' law, men born in 1893, being 20 years old in 1913, were called the 1913 class. Had they been summoned on Oct. 1 1914 they would not have taken part in the battles of the Frontiers or those of the Marne. When the three years' law came into force these young men joined the colours in the month of Oct. 1913, and in consequence, at the moment of the commencement of the campaign, they had between nine and ten months' service, and they did splendidly in the battles of the Frontiers and the Marne. It will be noted that these young men were 20 years old at enrolment, instead of 21 as under the previous laws. Fears, therefore, had been entertained that enrolment at so early an age would adversely affect them. For this reason the calling-up was postponed in the case of any conscript whose physical condition left anything to be desired. The 1913 class did not provide, therefore, at the moment of enrolment, more than 170,000 men instead of 210,000, which was the usual figure. Nevertheless, the three years' law was welcome at the moment, since it gave both the mobilized army and, in particular, the peace-time army an addition of strength equivalent to four army corps. From this aspect the vote of the three years' law was the capital point of the French army's evolution from 1910 to 1914.

The Germans, thanks to the greater size of their population and to their higher birth-rate, were able to increase each year their strength in peace-time; and, because in Germany the uniform was popular, the candidates for officers and non-commissioned rank of the active army and of the reserve were superabundant.

In these conditions it was feared in France that the weak units of the protective forces in the frontier regions might be suddenly overwhelmed, and the concentration of the armies behind them thereby made impossible. To build up in peace-time the strength of the units forming part of the *couverture*, and to increase the number of units assigned to it, was the principal aim of the three years' law. Commencing in the month of Oct. 1913, the corps of the Covering Force were filled up with the numerous contingents of young soldiers of the 1912 and 1913 classes; this increase was so considerable that the peace strength became almost that of a war footing. The period of Oct. 1913 to May 1914 was extremely critical, owing partly to the overcrowding in the old barracks or in those being constructed and partly to the want of instructional facilities for the increased number of recruits. If the war had broken out during the transitional phase, difficulties without number would have had to be overcome. Fortunately, this did not happen.

At the same time that the three years' law increased the strength in men, it increased also the number of horses in the cavalry and artillery. In consequence of this, the units of the territorial army found themselves able to take the field almost with their peace-time organization. The difference between peace and war strengths was about four to five. This allowed the reservist element to be easily absorbed in the active element. At no point in the immense field of battle of Aug. 1914 did any weakness manifest itself amongst the troops of the Covering Force; on the contrary, the II. Corps, XX. Corps, and Hache's Div. of the VI. Corps displayed prodigies of valour and saved some situations which were extremely delicate.

The formations of the Covering Force were favoured with regard to cadres, in comparison with other units of the interior. Since they were liable to be attacked immediately after, and perhaps without, a declaration of war, it was desirable in the meanwhile to maintain them almost on a war footing not only with men but with cadres. But, without denying the value of the advantage of possessing cadres almost at war strength which the Covering Force enjoyed at the expense of the army of the interior, it must be recognized that the preponderant influence is the age of the troops. The corps of the Covering Force were younger than the corps of the interior, the latter were younger than the reserve divisions, and the divisions of the reserve had not the age of the territorial army. This is not the place to argue that age freezes the courage—that question lies in the domain of psychology and must be left to research in that branch of study. It may be affirmed, however, that the process of acclimatiza-

<sup>1</sup> In France the "territorial army" is formed on mobilization from reservists (officers and men) of the older classes.



tion necessary in turning from the habits of peace to the trials of war is harder in proportion as youth has passed and the instruction acquired during the years of service with the colours has been effaced by time. If this applies to the French it is equally true of the Germans. In the early days of the war, when of equal ages, the French and Germans found themselves on an equal footing; but where the Germans were younger they won.

Now, in any case, the French population consisting of 40 million souls, and the German of 70 million, in one mobilization class Germany had seven soldiers to France's four. But, further, it was especially in the 30 years prior to the war that the difference in the birth-rates made itself felt. One can say then without appreciable error that the last classes called to the colours gave eight to Germany and only four to France.

The army corps of the French Covering Force, in which 80% of the personnel consisted of the three youngest classes, had a mean age of 22-22½ years. The army corps of the interior, composed half of men of the younger classes and half of reservists, had a mean age of 25-26 years. The reserve divisions had a mean age of 31-32 years. The army corps of the German active army had a mean age of no more than 22 years in the Covering Force, and 23-24 years in the interior, while the German reserve army corps had one of not more than 25-26 years. In brief, all the army corps of the Germans, whether active or of the reserve, were still under the influence of the lessons acquired during their active military service, while the French reserve divisions had everything to relearn.

Therefore, if one is to compare the strengths present in the Frontier battles, one must not count the divisions of French reserve any more than the reserve brigades which followed the active army corps, or only count them as of very small value. For battle purposes the numerical superiority must be considered in the first encounters to have been in favour of the Germans. But the reserve divisions quickly recovered themselves; their acclimatization was rapid. Already at the battle of the Meuse there was notable progress; at the Marne, where they were led vigorously, they called forth the respect of the enemy.

In 1914 France was organized to place under arms the whole population capable of carrying arms. It has already been remarked that the stages of evolution towards the ideal of 1793 were slow. Even after Sedan, Gambetta was able only to call up men by categories—first the unmarried, then married men without children. Only in 1905 did service become obligatory, personal and equal, and it was not until 1913 that the law was reached which saved France by giving, with equality, a strong peace army which could absorb the number of reservists and cover the mobilization and concentration. It is important to note the fact that while on Aug. 22 1914—that is to say, three weeks after the order of mobilization—the army corps of the Covering Force were complete, the army corps of the interior were only just ready, the divisions of the reserve were not up to the mark, and the units of the territorial army were still valueless. This respite of three weeks which the French army enjoyed arose from two causes: the resistance at Liège and the extension which the Germans gave to their enveloping manoeuvre. It may fairly be asserted that it was the reinforcement of the French Covering Force, much more than the value of the French fortresses, which caused the German staff to seek to gain the valley of the Oise by the right of the army before the attack. And the resistance of Liège aggravated the effect of the delay inherent in this place of attack.

The evolution of the French army from 1910 to 1914 in respect of its strength, the reinforcement of the Covering Force and the peace-time order of battle, thus saved France in spite of the absence of a natural frontier which exposed her to the greatest difficulties, if not to actual defeat.

When the war of movement ended and trench warfare commenced, it was bitterly regretted that the factories had been emptied of all their mobilizable workers; the very principles which had governed the evolution of the army towards universal, personal and equal service were blamed. It was deplored that these men had not been left at work in their workshops whilst the others went to fight.

It may be that these reproaches were ill-founded. If the 559,000 men who on July 1 1917 were in factories had remained there in Aug. and Sept. 1914 instead of going to the war, perhaps there would have been munition in the arsenal; but perhaps also the French army might not have had need of them, because they would have been beaten by the numbers of the enemy.

It is not justifiable, then, to say that the evolution of the army between 1910 and 1914 was on wrong lines. It was because the Germans gave so wide a sweep to their enveloping movement that space and time allowed the French commander-in-chief to place on his left wing the V. Army and a group of reserve divisions, and to get in touch with the English army. This space and time Prussia had meant to refuse to France in 1871 in drawing the new frontier. To gain space and time had been the object of those who had organized the defences of the mutilated frontier; it was the purpose, equally, of the troops of the Covering Force. To lessen the allowance of space and time required for the French army to mobilize and concentrate on the frontier was the constant preoccupation of the staff from 1875 up to the month of Aug. 1914.

The Covering Force.—It is not possible here to deal with the organization of the fortresses which gave a military frontier to France,

deprived as she was of every natural frontier. We shall limit ourselves to defining the operations which had for their object the creation of a strong Covering Force. These operations determined the order of battle of the French Army.

In the first place there was built up one higher formation to which almost exclusively was entrusted the duty of forming a Covering Force to face Germany; the VI. Corps was this great unit. Alone this army corps watched over the frontier in 1875—Neuf, Germany having placed in Alsace-Lorraine very large numbers, France, in order to keep the balance, had to augment the number of units of the VI. Corps. This, becoming too cumbersome, was divided into two—the VI. (headquarters, Châlons) and the XX. (headquarters Nancy). At the same time the region of the VII. Corps (Besançon) was extended to the N. of Belfort as far as the Upper Moselle. This was the position in 1910, when, since Germany showed herself not only more and more aggressive but also more and more strong, it was decided to give the frontier, by the organization of the Covering Force, the means of gaining, if not space, at least the time necessary to put in position in a prearranged order of battle the great military units mobilized by France. For this purpose it was necessary to have the men whom the three years' law provided. When they were promised, a new order of battle was adopted. A new army corps, the XXI., was created, with the duty of providing the covering force in the region of the Vosges. The II. Corps (Amiens), which was a corps of the army of the interior, had its regional limits completely altered; the district adjoining Belgium (Givet to Thionville) was allotted to it, and one of its divisions increased to three brigades furnished the Covering Force from Briey to Givet.

Each corps of the Covering Force became in a fashion the advanced guard of an army. The XXI. Corps was the advanced guard of the I. Army; the XX. Corps that of the II. Army; the VI. Corps that of the III. Army; and the II. Corps became on Aug. 9 1914 the advanced guard of the IV. Army. The I. Corps acted as an advanced guard to the V. Army, sent towards the Sambre, and on the other flank the VII. Corps, when strongly reinforced, became the army of Gen. Pau, operating towards Mülhausen. Behind this formidable system of the six corps of the Covering Force, the commander-in-chief under Plan 17 could put his armies into position. Immediately prior to the war, Gen. Joffre had improved in detail the measures taken for mobilization and concentration in order to avoid as far as possible any loss of time; he sought to gain even hours, in the hope of saving the corps of the Covering Force from having to give ground, by speeding up the intervening stages between the date of the opening of hostilities and the time at which the armies would be strategically concentrated.

Strength.—The French army in peace-time consisted of 21 army corps and three divisions of colonial troops available for service on the frontiers. Of these 21 army corps, the arrival of the XIX. Corps, stationed in Algeria, in time for the first battles was counted upon, though problematical. In addition there were 10 divisions of cavalry. On mobilization the units of the active army were brought to their war strength by the influx of reservists; there was created on an average one division of reserve for an army corps.

In the Frontier battle, Gen. Joffre had under his command not only the 44 divisions of the active army at home but also three active divisions drawn from N. Africa and the Alps, and 25 reserve divisions—a total of 72 divisions of infantry and in addition 10 divisions of cavalry, giving a total of 2,669,000 men for the armies of the north-east.

By Sept. 1 1914 the French army comprised:—21 army corps, 50 active divisions, 25 reserve divisions, 12 territorial divisions, 10 cavalry divisions, army troops, and line-of-communication troops. Altogether there were 62,145 officers and 2,689,000 men—1,135,000 rifles, 25,000 carbines, 106,200 sabres, 2,158 machine-guns, 4,098 field guns, 389 heavy guns, 192 mountain guns, 200 aeroplanes and 18 balloons.

If in addition to the troops which Gen. Joffre was able to place in the battle of the Frontiers, there are added the Belgian army of 6 infantry divisions and one cavalry division, the 4 British infantry divisions which in the first place Field-Marshal French brought, with one and a half divisions of British cavalry, the conclusion is reached that the loss of this battle was caused, not by disproportionate numbers, but by various other factors, amongst which, as already noted, the initial lack of efficiency of the French reserve divisions must be given a prior place.

The order of battle of the French army comprised five armies, allowing four armies to be placed side by side in the first line, and one army in reserve behind the centre and left centre. Each army had at least one division of cavalry in reserve. On the left near the Belgian frontier there had been assembled a cavalry corps. Reserve divisions were placed in the centre of the battle front, between the II. and III. Armies, to carry out the investment of the fortified region of Metz-Thionville or to bar the enemy from the Meuse heights between Verdun and Toul as required. Other reserve divisions were entrusted, concurrently with certain active forces, with the defence of the region of Ste. Geneviève, in front of Nancy and Frouard. A "group" of reserve divisions was brought to the right rear, and a similar group to the left rear of the long line. Belfort, Epinal, Toul, Verdun, Mauberge received their war garrisons. Lille was declared an "open town" by the Ministry of War. Lastly,



a group of territorial divisions under the command of Gen. d'Amade in the region W. of the Oise was dignified by the name of an army.

Each army had a number of army corps varying according to the different missions of these corps. Thus, for example, the IV. Army, which under Plan 17 (wherein this army was in reserve) had only 3 army corps, had 6 army corps in the Ardennes battles, with, in addition, 2 reserve divisions. A temporary army was formed for the invasion of Alsace under Gen. Pau; this was broken up when Joffre observed how seriously the left flank of the Allies was compromised. An army, called the Lorraine Army, existed for some days in Woëvre; it was broken up before even the neighbouring forces knew of its existence. A sixth army was organized near Amiens; this was the army which, reconstituted at Paris, fought the battle of the Ourcq. A ninth army, which at first was an "army detachment" under the IV. Army, was formed during the retreat and fought gloriously at the Marne. In the course of the war, armies were created, broken up, and created anew as the needs of the case demanded. Thus there was formed at Salonika an Army of the East.

After the loss of the Meuse heights, which followed the loss of St. Mihiel, the commander of the III. Army was for a time brought under the authority of the commander of the I. Army. This was the origin of the creation of "Groups of Armies." These had the advantage of simplifying the task of the commander-in-chief, which had become heavier and heavier; but it was evident during the offensive of April 1917 that this part of the machinery was capable of bringing its movement to a standstill. Opinions formed on this subject seem unanimous in considering the army group a temporary formation intended to achieve coordination of movement when many armies were seeking the same objective while the commander-in-chief had too many other urgent occupations to act himself. In 1915 there were three groups of armies, East, Centre, North. For the offensive of 1917, and again for the spring campaign of 1918, groups of armies designated "reserve" (G.A.R.) were formed. In the final advance of Sept.-Oct. 1918 a group of armies of Flanders was formed of Belgian, French and British troops under King Albert.

An "Army Corps" in principle was composed of two divisions of the active army and corps troops and included especially one brigade of the reserve. But certain army corps in Aug. 1914 had 3 divisions—the VI. Army Corps for example. The II. Corps mobilized 5 brigades, but it lost almost at once the 8th Bde, which was attached to the cavalry corps. In the course of the campaign during the stationary period, an army corps was often no more than a sector where troops collected either for battle or for enjoying a period of comparative rest. The number of divisions was extremely variable, as was also the allotment of artillery in a sector.

An infantry "division" originally consisted of 2 brigades of infantry, a company of engineers and a regiment of artillery. In order to give greater mobility and to decrease the proportion of infantry in comparison to the number of guns, one regiment of infantry was suppressed. The tertiary order prevailed not only in the regiment of infantry but also in the battalion. The cavalry division did not undergo any great change during the war, although in 1915 two sections of machine-guns were added. The proportion of engineers was increased while many regiments of cavalry were dismounted or broken up.

A cavalry corps was composed of a variable number of divisions of cavalry. On the left wing of the French army the general-in-chief constituted, from the concentration, a cavalry corps in strength of 3 divisions. During the battle of the Meuse, the commander of the IV. Army created a cavalry corps from 2 divisions which had been at that moment attached to him. In front of the I. and II. Armies a cavalry corps was also created for a brief time. In fact, the cavalry corps did not exist as an organized formation; when two or more divisions of cavalry were placed under the same commander the group thus formed was often called a cavalry corps. A division of cavalry had 3 brigades of cavalry and a group of batteries.

Many were the variations through which the order of battle passed in the course of the war. But it is of special interest to mention what the French army of 1914 had become in 1918 when the war was ended; the numbers can be compared with those shown above.

In 1918 there were at the front—88,488 officers and 2,846,000 men—450,000 rifles only (about one-third of the number in 1914), 400,000 carbines, 33,800 salvers, 19,149 heavy machine-guns, 46,800 light machine-guns (an arm which had not been employed in 1914), 936 guns of 37 mm. calibre, 1,874 Stokes mortars, 36 motor-mounted 37 mm. gun, 208 motor-mounted machine-guns, 6,618 field guns (75 mm.), 7,100 heavy guns, 260 mountain guns, 2,275 guns of position and trench artillery, 3,379 aeroplanes (which the programme for 1919 increased to 6,000), 77 balloons, and 2,385 (a little later 4,626) tanks. In 1914 the army had 19,000 vehicles; in 1918 there were 88,500.

Under the law of Dec. 23 1912, the French infantry in peace-time comprised 173 regiments, of which 164 had 3 battalions of 4 companies each; 8 "fortress" regiments had 4 battalions, and one regiment stationed in Corsica had a variable number of battalions. There were 31 battalions of *chasseurs-à-pied*, of which 18 (6-company) battalions were on the N.E. frontier and 13 were Alpine battalions (6-company also). Four regiments of Zouaves had a variable number of battalions (4-company). Twelve regiments of native *tirailleurs* were composed like the Zouave regiments, but with

a depot company in addition. Further, there were 2 foreign regiments, 5 battalions of African light infantry and a number of Sahara companies. The single regiment of firemen engineers of Paris furnished excellent cadres for the units dispatched to the front when after the Marne a shortage occurred of non-commissioned officers and subaltern officers. In principle each active regiment of infantry formed a reserve regiment of 2 battalions. The territorial army was formed of 145 regiments of varying composition according to the resources of the recruiting district; it included 7 territorial battalions of Chasseurs, and 12 territorial battalions of Zouaves. The infantry was armed with the Lebel rifle, model 1886-93. There was one machine-gun section for each battalion of infantry and Chasseurs. Owing to the slowness with which the French Parliament granted the necessary sums, territorial units were not provided with machine-guns at the outset of the war.

The cavalry was composed of 91 regiments, of which 10 were African troops. Each regiment had 5 squadrons in peace and 4 in war. However, the 6 Spahi regiments continued with 5 squadrons. In principle each army corps had a regiment of cavalry, and each division of infantry had a squadron. The other regiments of cavalry formed 10 divisions of cavalry of 6 regiments each. The term "Heavy Cavalry Division" was sometimes applied to those comprising 4 regiments of dragoons and 2 regiments of cuirassiers; that of "Mixed Division" to those composed of 2 regiments of cuirassiers, 2 regiments of dragoons and 2 of light cavalry; and that of "Light Division" to those of 4 regiments of dragoons and 2 of light cavalry. The cavalry was armed with the sabre, carbine, and, in certain regiments of dragoons with the lance. Each division of cavalry was allotted a group of horse artillery and a cyclist company.

The artillery comprised 62 regiments of field artillery, in 3 or 4 groups of 3 four-gun batteries and 5 autonomous groups in Algeria and Tunis. There were 635 field batteries, 24 batteries of mobile medium howitzers, 35 batteries of heavy artillery, 22 batteries of mountain guns, 40 batteries of horse artillery, 75 batteries of foot artillery—altogether 820 batteries.

The engineers were composed of 8 regiments, of which one was a railway and one a telegraph regiment. These regiments formed 26 battalions, varying from 3 to 7 companies.

The air force had 4 balloon companies and 3 aviation companies; and in addition 10 aeronautical sections and one transport company.

The colonial troops formed 16 regiments of colonial infantry, of which 12 were in France and 4 in the colonies. There were 5 independent battalions and 2 independent companies in the colonies; one regiment of Annam rifles, 4 regiments of Tonkin rifles, 4 regiments and 8 battalions of Senegal rifles, 3 regiments of Madagascar rifles. The colonial cavalry consisted of 2 squadrons of Senegal Spahis, one squadron of natives of Congo and Chari, and one squadron of Indo-China natives. The colonial artillery comprised in France 3 regiments forming 96 batteries, of which 18 were field and 6 mountain; in the colonies were 4 regiments and 2 independent groups. Finally in Morocco there were 6 mixed regiments with 3 battalions, of which one was a colonial battalion and 2 were Senegal rifles.

The French army had 21 army corps, but the XIX. Corps (Algeria) was not, during the World War, brought into the field armies as such. However, 2 African divisions were brought over and attached to the V. Army, so that the troops figured at the front.

The active divisions of the metropolitan army (including 19 corps) were numbered from 1 to 43; some special designations were given to new divisions formed on mobilization from active troops not included in the 20 corps of the metropolitan army present in France. The reserve divisions were numbered from 51 to 75. The designation "reserve" was abolished in 1915. Territorial divisions were given numbers above 80. Higher-numbered divisions were formed by reconstitutions from existing divisions, from 1915 onwards. These had numbers above 100.

The only exterior theatres of war in which France employed large formations were the Dardanelles, Salonika and Italy.

In the Dardanelles campaign the expeditionary force was eventually of about the strength of 2 divisions. These were afterwards regularly constituted as the 156th and the 177th Colonial Divs. At Salonika there were, in addition to the two Gallipoli divisions, the 57th Div. and the 122nd and 211th Colonial Divs., to which were added in 1917 the 16th Colonial, 30th and 76th Divs. In Italy, in the winter of 1917-8, there were 6 divisions detached from the French front, of which 2 remained to the end of the war, being replaced in France by 2 Italian divisions. Smaller forces were employed at Cyprus (1916), and in Syria and Palestine; in the African campaigns; in North Russia, and elsewhere. (V. L. E. C.)

### III.—BELGIAN ARMY

In 1910 recruiting for the Belgian army was still regulated, under legislation of 1902, on a voluntary basis, completed by drawing by lot. The peace effective strength was 42,800 men, and the effective total of the field army on mobilization was fixed at 100,000 men.

By the statute of 1913 Parliament established the principle that the defence of the home country was an obligation charge on the family. Each family must furnish one son at least for military serv-

ice. This reform placed at the disposal of the army an annual contingent of about 33,000 men. This increased considerably the effectiveness subject to recall on mobilization, and caused a complete reform of the army organization. The new organization was chiefly instituted from a desire of assuring during times of peace a direct liaison between the two principal arms—infantry and artillery. This was achieved by the formation of a mixed brigade which was formed from a regiment of infantry and a group of field artillery.

On a war footing, and a reorganization now effected, there would be 6 army divisions and one cavalry division. This was the scheme under which the Belgian army found itself involved in war in 1914. It provided for an effective strength of 350,000 men, of which 100,000 were fortress troops; but this would not be reached before 1918, when the recruiting law would have been recalled to 6 classes of militia. As in 1914 the total of 8 junior classes applicable to the colours did not provide more than a total of 117,000 men, it was found that the field army, while mobilizing so vast a cadre, yet possessed effective units of extreme weakness only. Further, at the outset of the campaign the infantry units did not count in soldiers but in cadres—or half only of their strength. In fact the war surprised the Belgian army in the midst of reorganization. (1) The order for heavy Maxim machine-guns had only been completed in part; a certain number of companies in the field army were equipped with Hotchkiss machine-guns which were taken from the armament of the fortresses. Owing to the lack of a fixed regimental scale of transport, all machine-guns were carried in requisitioned transport and this paralyzed their use. (2) It was intended that the divisional artillery regiment would have a group of field guns and two groups of 9.5-in. howitzers. When war was declared there existed in the whole army only one group of howitzers; the artillery of the whole army was equipped only with 75-mm. guns. The adoption of a 15-cm. howitzer was still under consideration. (3) The number of cavalry regiments should have been raised from 8 to 12, but only 3 of the 4 new regiments had been created; the cavalry divisions possessed 2 brigades instead of 3. (4) The Air Force possessed a single squadron of one dozen aeroplanes. The infantry were armed with the Muser rifle of 1889 type, firing an ordinary pointed bullet.

After the battle of the Yser the Belgian army consisted of only 32,000 rifles. This excessive reduction of effectives caused the suppression of the mixed brigades. Each army division consisted of 3 mixed regiments (one regiment of infantry and one group of artillery). The 3rd Div. alone had 3 mixed brigades. It was with this composition that the army spent the whole winter 1914-5. The excess of artillery permitted the placing of 2 regiments of this arm at the disposal of the 27th and 28th Divs. (British) in the Ypres salient.

A few days after mobilization the Government had decreed the calling-up of the 1914 class. This contingent, and voluntary enlistments at the outbreak of war, formed a feeding reserve of 50,000 men, who were at first collected in the depots around Antwerp and later taken to the district of the Pas-de-Calais after the evacuation of that fortress.

In the spring of 1917 the army was reorganized in view of its participation in the general offensive projected by Gen. Nivelle. The number of machine-guns employed was considerably increased. Ignoring a similarity of type of weapon, but keeping to a single type of machine-gun in each division, companies of 6 machine-guns were raised for each battalion of infantry. The adoption of the French light machine-gun at the rate of 6, and later of 9, weapons per company, allowed a reduction of the effectives in the company to about 180 men. As a result it was possible to increase the regiments to 4 battalions of 1,000 men in a brigade of 2 regiments of 3 battalions, each battalion being formed of 3 companies of infantry and one company of machine-guns. Later, the acquisition of a certain number of howitzers permitted each division to possess some fairly heavy material, and created further a brigade of 2 regiments of heavy artillery. Hence the composition of an army division in 1917 was: headquarters; 3 brigades of infantry of 2 regiments of 3 battalions; one brigade of artillery; one regiment of engineers of 2 battalions; one light group of 2 squadrons of cavalry, and one company of cyclists. Thus formed, the Belgian army at the front on Sept. 1 1917 at the period of the British offensive at Ypres, had 168,000 men, of whom 5,700 were officers.

In order to maintain the strength now reached, and to prepare for the normal wastage of stationary warfare, it was decreed by law that personal service was obligatory for all Belgians between the ages of 18 and 40 years living outside the invaded territory.

The Belgian army found itself ready a year later—in Sept. 1918—to join in the offensive attack in Flanders with 170,000 men, despite the fact that 30,000 were serving in the hospitals, in military factories, in munition parks, and other subsidiary services.

The organization of the Belgian military system which developed after the war as a permanent element in the institutions of the country may be summarized here. The royal decree of July 1917 made army service universal and obligatory, but till the end of the war it had been possible to apply it only to those Belgians living in the uninvaded territory; that is to say, to a very small fraction of the annual contingent. Immediately after demobilization it was decided that all men of the classes 1914-5-6-7-8 of the invaded portion of the country who had not served during the war should be called in succession under arms, each military contingent following the other

at about 6 months' interval. This measure was in 1921 in process of being carried out.

The term of service with the colours was that ordered by the law of 1912, viz.—Infantry and engineers, 15 months; field artillery, 21 months; horse artillery, 24 months. However, "breadwinners," i.e. the married men or those of good conduct who supported families, were allowed to return to their homes after 4 months of instruction only.

In Oct. 1920 the Minister of War, yielding to the pressure of public opinion which favoured a reduction of military expenses, decided that in the transitory period until the completion of training of the backward classes, i.e. until 1922 (having regard to the fact that during this period 2 whole classes will be under arms), the terms of active service were to be reduced for the time being to 10 months for infantry, 12 months for engineers and fortress artillery, 17 months for cavalry and horse artillery.

*The Peace and War Organization.*—The constitution of "army divisions" (practically equivalent to army corps) is as shown below. Certain modifications, however, were under consideration in 1921 with a view (a) to augmenting the number of machine-guns, with the final object of forming a machine-gun battalion per infantry division, (b) to developing the technical services, (c) to increasing the aviation and the heavy artillery of the army.

Army divisions (6 in number) consist each of 2 infantry divisions and other troops. The infantry division consists of 3 infantry regiments, one artillery regiment, and one engineer battalion. The corps troops, as they may be called, consist of a battalion of cyclists, a regiment of cavalry, a regiment of heavy artillery, and a battalion of engineers.

There is one cavalry division consisting of 3 brigades (each of 2 regiments) with divisional troops (one group horse artillery, one group of motor automatic guns, two battalions cyclists, one cyclist company of engineers).

Army troops not assigned to army divisions are: a brigade of 3 heavy-artillery regiments, an air force of one balloon battalion and 2 aeroplane squadrons, a telegraph battalion, a searchlight battalion, a bridging battalion and a railway battalion. (R. VAN O.)

#### IV.—THE RUSSIAN ARMY

Under the Imperial Russian Government, the Ministry of War, on its military side, included (a) the chief council of the general staff, which controlled all questions relating to the development of the armed forces of the empire and the use of them in the event of war, and (b) the general staff itself, which controlled the conditions of military service and the inner life of the army. The chief council of the general staff was only formed in 1905, after the Russo-Japanese War. This allocation of the more important questions to a special body, presided over by the chief of the general staff, was a measure highly important for ensuring the carrying-out of basic reforms and improvements. At first the head of the general staff was exempted from subordination to the War Ministry and reported directly to the Tsar on questions under its jurisdiction, but after 3 years the existence of 2 bodies reporting on military matters was acknowledged to be inconvenient, and the chief council of the general staff was again included in the composition of the War Ministry. In it there were gradually concentrated questions relating to the constitution of the army and the working-out of war plans. The first head of the Russian general staff was Gen. Palitsin, who occupied this position from 1905 to the end of 1908; he was subsequently succeeded by Gens. Sukhomlinov, Mishlaevskiy, Gerngro, Jilinsky and Jenushkevitch; the last named was appointed only a few months before the outbreak of the World War. With the advent of war, the troops assigned for military operations were entirely removed from the control of the War Ministry; the control of them was organized according to a special "Order for the control of troops in the field in war time." This order was confirmed by the Tsar on July 16-29 1914, i.e. only 3 days before the declaration of war on Russia on the part of Germany. The order mentioned fixed the organization of the higher command, the arrangement of the rear of the troops assigned for military operations, as well as the duties, rights and sphere of jurisdiction of the commands in the field.

The highest troop division in peace time in Russia was the corps. Though the corps often formed part of the military district, this unit had rather a territorial than an operative character, and its commanding personnel served only as the basis for forming the higher commands in war time. The order on command in the field provided for the grouping of the corps in armies, and of armies into larger combinations, called "fronts." The whole of the troops, those

forming the composition of a "front," as well as those remaining in the composition of separate armies and even corps, formed the operating army.

The supreme command of all the forces was, in the event of the Tsar not wishing to assume it personally, entrusted to a supreme commander-in-chief, who had the right to order military activities according to his own independent judgment. No Government institution, nor any person in the empire, with the exception of the Tsar, had the right to give the supreme commander-in-chief orders, or to hold him to account. At the head of a "front" there was a commander-in-chief, and at the head of each "army" a commander, who also enjoyed very extensive responsibilities. The supreme commander-in-chief had to fix his attention mainly on the conduct of military operations. The question of the supply of his troops with all necessities, in the broadest sense of the word, was left to the care of the supply bodies of the War Ministry, who were entrusted with general requirements only. Besides the conduct of military operations, the supreme commander-in-chief retained the higher command in the exploitation of the net of railways in the theatre of military operations, a control which was highly important, in view of Russia's poverty in railways generally. The staff of the supreme commander-in-chief was very limited; it consisted of 45 officers, 10 civil servants and 2 men of medical rank.

The commander-in-chief of a "front" was a man who controlled not only the military operations of his front, but was likewise responsible for the provision of all the requirements of the armies subordinated to him. To make it possible to carry out the second half of his duties there was subordinated to him a part of the territory forming the theatre of military operations with all the materials in that territory; this formed the rear of the army of the given front, everything that could not be procured on the spot had to be ordered, in good time, from the interior of the empire through the supply bodies of the War Ministry. His headquarters consisted of a staff and a series of commands, subordinated to the head of supply, who carried out all the plans of the commander-in-chief relating to domestic administration. The territory composing the rear of the army of the front formed one or more military districts, the commanders of which were subordinated to the commander-in-chief through the head of supply. Lastly, the headquarters of the commander of an army was regarded and organized as the executive organ of operations.

The system created by these regulations did not suffer any material changes in the course of the first two years of the World War. It was only in 1916 that the personnel of the supreme commander-in-chief's staff began to increase; it was found expedient to include in it a whole series of new departments for which no need was felt in the first two years of war.

The basis of the Russian military system was the regulation relating to military obligations, which fixed the terms of military service. To turn fully to account one of the main advantages of Russia over the other European Powers was the numerical superiority of her reserve man-power, and also to carry out other improvements, the general council of the general staff elaborated in 1911-2 a new scheme of compulsory service, which was approved by the imperial Duma and the Senate. According to this, military obligation was extended over the whole of a population which counted 150 million, the fit male population (between the ages of 18 and 43) consisting of over 26 million. This was the reservoir on which Russia could depend for the replenishment of her army in time of war. It could have been further increased by calling up the different classes even before their time, as well as by extending military obligations to the different races in the country and to men of over 43, but the two latter methods were difficult to carry out, owing to the conditions of Russian life.

The new organization of the army was completed in 1910. It brought many changes, but was not successful in fully realizing the scheme mentioned, as, in carrying out the fundamental part of the work, two grave limitations were set. These were that the new arrangement of troops must bring no change in the yearly contingent of recruits and in the amount of permanent expenses allocated for the maintenance of the army. These conditions resulted in the infantry being left with 4-battalion regiments and the field artillery with 8-gun batteries. These defects in organization were rectified later, but only during war itself.

The principal reform carried out in the infantry consisted rather in a considerable increase in the numerical composition of the field-infantry units than in a material strengthening of the cadres of the first-line units, who formed the kernel of the army in war time. Machine-gun and communication units were introduced. The re-creating of the peace organization of reserve units enabled 7 new field divisions to be created. Lastly, in the formation of the second-line units, with an order for mobilization, the so-called system of "secret cadre" was adopted. Under this system, when the troops passed to a war footing, from each first-line unit there were taken a certain number of officers and men, who formed the cadre on which the second-line units were built up. This system was applied also to the field artillery. The organization of the cavalry and horse artillery remained, on the whole, unchanged. Howitzers were introduced into the field-artillery organization, and a beginning was made with the

formation of heavy artillery. In technical resources the army was insufficiently supplied, owing to the lack of credits and the difficulty of manufacturing the necessary materials in home factories.

In the middle of 1914 the Russian army was composed as follows: Of infantry there were 70 field divisions (1st, 2nd and 3rd Guard; 1st, 2nd, 3rd and the Ciscaucasian Grenadiers; 1st to 3rd Infantry; 1st to 11th Siberian), each with 4 regiments of 4-battalion strength; 18 light or "rifle" brigades (Guard; 1st to 3th; 1st to 4th Finnish; 1st and 2nd Cossacks; 1st to 6th Turkestan and Kuban-Plastun brigades; 16 light brigades of 4, and 2 light brigades of 3-battalion regiments; the Kuban-Plastun brigade had 6 Plastun battalions. In war time there would be formed another 36 second-line infantry divisions (53rd to 85th Infantry and 12th to 14th Siberian); in addition, certain infantry brigades of varying establishment would be so formed as to be able to expand into divisions. Of cavalry there were 24 divisions (1st and 2nd Guard; 1st to 15th and Ciscaucasian cavalry; 1st and 2nd Cossacks, 1st to 3rd Ciscaucasian Cossacks, 1st Turkestan Cossacks), each consisting of 4 (6-squadron or 6-sonnia) regiments, excepting the 1st Guard Div., which had 7 regiments; 8 independent brigades (Guard; 1st to 3rd cavalry; 4th Cossack), each having 2 or 3 regiments; and a few smaller units. In war time the number of cavalry units was not increased; the number of Cossack cavalry units was supplemented by the formation of Cossack units of the 2nd and 3rd class from reserve men. In each infantry division was included an artillery brigade (6-8 batteries); in every light brigade an artillery group (3 batteries). The cavalry and Cossack divisions had attached horse artillery groups of two 6-gun batteries. All the troops mentioned were, in peace-time, formed into 37 army corps (Guard; Grenadier; I.-XXV. Army; I.-III. Ciscaucasian; I. and II. Turkestan and I.-V. Siberian). The normal corps consisted of two infantry and one cavalry division. Several corps had no cavalry at all; others had two cavalry divisions and an extra light brigade. In war time cavalry divisions fell out of the corps strength, and were worked as independent cavalry, by divisions. The army corps was supplied with corps cavalry, mostly of Cossack units of the second and third class. On the strength of every corps there was, besides the field-gun establishment, one mortar (howitzer) division of two 4-gun batteries and one sapper detachment. There were also several heavy-artillery units as well as pontoon battalions, railway, transport and air units, which were distributed in war time, according to a special plan, among the armies. Draft-finding units of infantry, artillery and engineers were formed only on mobilization by creating cadres from the corresponding field units. As for the cavalry cadres, draft-finding units were already maintained in peace-time as reserve cavalry regiments and divisions.

All the troops indicated above were not, in peace-time, evenly distributed over the territories of the empire, but were mostly concentrated on the frontiers, on the western frontier in particular. This system of distribution had been in existence from olden times, owing to the lack of railways and a desire to protect the frontiers as much as possible. The system, however, greatly complicated mobilization, as the principal sources for war expansion were nearer to the centre of the empire, and therefore, with an order for mobilization, the necessity arose of carrying out a considerable movement of drafts over long distances. In proportion as the net of railways developed, ensuring a quick supply of troops from the centre to the frontiers if required, one could observe a withdrawal in the permanent quarters of the troops from the frontier regions nearer to the sources for completion. This change was particularly marked in 1910, when 7 infantry and 2 cavalry divisions, with 2 staffs of corps, were moved from the western frontiers to the interior of the empire. This withdrawal aroused alarm at the time in France, and suitable explanations had to be made.

The whole territory of the empire was, for military-administrative purposes, divided into military districts (12 in number), at the head of which was the commander of the troops of the district. The distribution of the corps in the military districts was as follows:—

- |                   |             |                                    |
|-------------------|-------------|------------------------------------|
| 1. St. Petersburg | M. District | Guard I., XVIII., XXII. Corps      |
| 2. Vilna          | " "         | II., III., IV., X., Corps          |
| 3. Warsaw         | " "         | VI., XIV., XV., XIX., XXIII. Corps |
| 4. Kiev           | " "         | IX., X., XI., XII., XXI. Corps     |
| 5. Odessa         | " "         | VII., VIII. Corps                  |
| 6. Moscow         | " "         | Grenad. V., XIII., XVII., XXV.     |
| 7. Kazan          | " "         | XVI., XXIV.                        |
| 8. Caucasus       | " "         | I. C., II. C., III. C.             |
| 9. Turkestan      | " "         | I. T., II. T.                      |
| 10. Omsk          | " "         | 10th Siberian Rifle Div.           |
| 11. Irkutsk       | " "         | II. Sib., III. Sib.                |
| 12. Pri-Amur      | " "         | I. Sib., IV. Sib., VI. Sib.        |

The local administration in Cossack districts was organized on a special basis. Of Cossack "armies"—i.e. autonomous forces—on Russian territory there were 11, namely the Don, Kuban, Terek, Astrakhan, Orenburg, Ural, Siberia, Semerechensk, Trans-Baikal, Amur and Ussuri.

The Russian army was placed on a war footing in 1914 on the "mobilization plan of 1910." A new mobilization plan, revised in certain respects, and known as "mobilization plan No. 20," had been drawn up in 1913, but in July 1914 full effect had not yet been

given to this; it was found necessary to discard it and to carry out mobilization by the somewhat out-of-date plan of 1910.

As every war is usually preceded by a more or less lengthy period of political complications, then, in order to safeguard mobilization, a declaration was previously prepared, called the "period preparatory to war," during which each unit and command was required to overhaul its mobilization scheme and complete any deficiencies, and to recall all ranks on leave or on detachment. This was proclaimed on July 26 1914.

There were in Russia in 1914 the following permanent fortresses or forts:—(a) *Land*: Kovno, Olita, Osowets, Lomza, fortifications on the river Narv, Zezrah, Novogeorgievsk, Warsaw, Ivangorod, Brest-Litovsk, Kara, Kushk; (b) *Maritime*: Kronstadt, Viborg, Sveaborg, Libava, Ochakov, Sevastopol, Kerch, Batum, Vladivostok, Nikolayevsk-on-Amur. Modern developments in military engineering had made all these fortresses very antiquated. The profiles of the fortifications were weak and could not withstand the power of the modern gun; camouflage practically did not exist. The artillery was of the most varied and of extremely antiquated types and ammunition was limited. In a condition such as this, the fortresses could not be a support for manoeuvre in the field, nor for that matter for operations at sea; on the contrary, they themselves needed the support of a living force. They demanded considerable numbers for their garrisons, and so further weakened the army in the field. Of the land fortresses, those of foremost significance were held to be the fortresses of Kovno, Osowets and Brest-Litovsk.

In 1914 the quicker mobilization and concentration of the German and Austro-Hungarian armies made it impossible to carry out the strategic deployment of the main forces of the Russian army on the Vistula. Thus, all the forts and fortifications on the river just mentioned, as well as on the Narv, were, to a certain extent, cut off. Their position, combined with the scarcity of means for reconstruction, as well as with the difficulty of carrying on defence from such a populous point as Warsaw and the necessity of providing large forces as garrisons, compelled the abandonment of reconstruction. An exception was made only in the case of Novogeorgievsk, which seemed to have future possibilities as a means of enhancing freedom of manoeuvre on both banks of the Vistula.

In the case of the maritime fortresses, attention was practically concentrated on Kronstadt, Sevastopol and Vladivostok; Kerch and Libava were suppressed.

In respect of railways Russia was very deficient, notwithstanding the fact that in the years immediately preceding the war several new lines were built, of which the most important, from a military point of view, was the new double-track line Bologoe-Sedlets. Taking the data of 1913, the density of railway lines in European Russia (1 km. per 100 sq. km.) was only one-twelfth of what it was in Great Britain. The amount of double-track lines was also small, altogether about 25% of the whole, when in other European states the percentage was as high as fifty. Rolling stock was likewise limited; to every kilometre there were hardly above 7 carriages, while in other countries of Western Europe it was twice and three times as much.

Macadam roads were sufficiently frequent in the main frontier regions adjacent to Germany, but away from those regions common roads only were available. The front adjoining Austria-Hungary had no macadam roads at all.

The war with Japan had to a large extent used up the military stores that Russia possessed, and the provision of new technical resources of war such as heavy artillery, means of communication, motor-cars, wire, machine-guns, air craft—involved the assignment of fresh large credits, and the manufacture of the necessary stores had to be spread over a number of years. Moreover, as industry in Russia was in a poor state of development orders had to be placed abroad and the execution of these was complicated by questions of financial procedure. This state of things resulted in the army, at the beginning of the war, being poorly supplied both with technical resources and reserves of armament. In certain respects the latter were not up to the recognized pre-war standards, low as these sometimes were (e.g. 1,000 rounds in reserve per light gun and per rifle).

In the beginning of 1914 the War Ministry had brought before the Legislature a bill for the allocation of credits for the further development of the armed forces, the so-called "great programme." The bill provided for the further strengthening of the cadres in the infantry and artillery, the supply of the army with heavy artillery in a larger proportion and the creation of new units which would be formed into two new corps. The bill was passed, but the advent of the war prevented its provisions from being actually carried out.

It is not possible to follow out in detail the development of the Russian army after the mobilization of 1914. The strength of the armies of the N.W., W., and S.W. fronts,<sup>1</sup> at different periods, is given by Gen. von Falkenhayn as follows:—

*Combatants only*

Mid Sept. 1914	950,000
End Dec. 1914	1,688,000
End Jan. 1915	1,843,000
End April 1915	1,767,000
End May 1916	2,240,000

The last date may be considered as the high-water mark of Russia's military effort. In spite of the enormous losses in men, material and territory of the campaign of May–Sept. 1915 Russia placed in the field for the combined Allied offensive of 1916 half a million more combatants than at any previous date.

The great Galician offensive was launched in June 1916. Its brilliant successes were won at very heavy cost, notably in the battles about Kovel. The effort died away into trench warfare. The Rumanian defeats stimulated a fresh spasm of activity in the winter of 1916–7, but the spring revolution of 1917 found the mass of the army, no less than the people at large, war-weary and dispirited by great sacrifices which seemingly brought peace no nearer. As is well known, the main contributory cause of the disasters of 1915 was shortage of ammunition, and it was only by the expenditure of lives instead of material that the Russian command was able to limit, as it did, the consequences of these disasters. What is less well known, but historically almost as important, is the fact that even in 1916 the material equipment of the fronts was at a low level. The victories of that year were won by the same methods as those which stemmed the tide of defeat in 1915—ruthless expenditure of lives. A great effort to remedy material deficiencies had indeed set in at the eleventh hour. Between July 1915 and the end of 1916, the ill-developed industries of Russia were revolutionized—the Tula rifle factory, for instance, having an output in 1916 six times as great as its output in the year of the war with Japan, besides turning out 1,140 machine-guns per month. At one period the output of gas shell was comparable to that in Great Britain. Owing, however, to the immense extent of the front, even the utmost possible developments of Russian industry would not have sufficed, and assistance from Great Britain and France was necessary to supplement it. This assistance, taken together with home output and the aid of America, as an ally, would probably have placed the Russian army on a satisfactory basis as regards equipment by the early autumn of 1917. But before the home effort could bear fruit and Allied assistance was available, the strain on the army had become too heavy.<sup>2</sup>

In the conditions, the disintegration of the Russian army which followed the spring revolution of 1917 scarcely requires explanation. An iron discipline, far more inflexible than that of any army of Western or even Central Europe, had been strained to the utmost, when its foundations suddenly crumbled, and the chance of creating a new discipline, such as was created by Carnot in the French army of 1793–4, was let slip in the chaos of conflicting ideals and policies which constitutes the tragic history of 1917, both inside and outside Russia. The last effort of the old army, the Galician offensive of July 1, for a moment shook the solidity of the Austro-German defence. But once more Germany was able to transfer troops (14 divisions) to the East, for the German offensive had collapsed and the mood of the French army was passing through a crisis which compelled inaction. This time the German command determined to finish matters in the East. First-quality divisions, employed on well-chosen parts of the front and using new methods of attack, closed the history of the eastern-front campaigns in the battles of the Sereth (July 19) and Riga (Sept. 1).

During 1918 the final dissolution of the old army completed itself in the civil wars. The original military forces of the Soviet Government were a militia—the so-called Red Guard; this was replaced gradually by a regular army. But neither the "Red Army" nor the armies raised by the different counter-revolutionary leaders, derive directly from the imperial army. Thousands, perhaps hundreds of thousands, of individual ex-officers and ex-soldiers figured in these new organizations and imparted to them the routine practices, the uniforms, and many of the characteristic customs of the old army. But no organic continuity exists between old and new. The peace of Brest-Litovsk and the civil wars constitute not a new chapter but a new book in the history of Russian military institutions.

No detailed information is available as to the losses of the Russian army from 1914 to the peace of Brest-Litovsk. The most probable estimates give 1,700,000 dead and 2,500,000 prisoners<sup>3</sup>—"definitive" losses, i.e. exclusive of wounded, but in the absence of the data from which those estimates are built up, all that can be said is that Russia lost more heavily in men than any other belligerent on either side.

(C. F. A.)

<sup>1</sup> No information is available as to the total ration strength of the Russian armies at different periods of the war, nor of the combatant strength of the forces on the Caucasus-Persia front.

<sup>2</sup> The contrast between Eastern and Western standards of armament may be illustrated by comparing the French artillery strength at the battle of the Somme (July 1 1916) and the Russian artillery strength at the battle of the Strypa (Yastoviet) on June 6 1916, both being deliberately prepared offensives against an entrenched front:—

<i>Somme</i>	Frontage of VI. Army	10 m.	444 field guns	645 medium and heavy guns and howitzers
<i>Strypa</i>	Frontage of II. Corps	14 m.	160 field guns and howitzers	23 medium guns and howitzers

## V.—ITALIAN ARMY

At the outbreak of the World War the Italian army was in a very unsatisfactory condition. Political leaders, and Parliament and public opinion generally in Italy, had for years held the view that the era of great wars was past, and that in any case pacific intentions gave a practical assurance of peace. For this reason it was judged sufficient to have an army which was strong enough to preserve order in the country and give to foreigners the impression that Italy was not completely disarmed. As a consequence the State had neglected the army, and its efficiency in comparison with those of its neighbours, to which continued attention had been paid and on which expenditure had continually increased, had been gradually diminishing. In 1907, however, the Government of the day had been induced to nominate a commission to study the faults and gaps in the military organism and suggest means to remedy them. In 1910 this commission had presented a programme fitted to the financial capacity of the country and its ideas; that is to say, a very modest scheme. But the Government found that the proposals were excessive and decided to adopt a reduced programme. And, as if that were not enough, the Government was so slow in carrying out this programme that in 1914 it was not yet completed. It was in April of that year that Gen. Porro refused to go to the Ministry of War unless a new programme were adopted, involving the expenditure of 600 million lire, spread over a period of six years. The programme was cut down by two-thirds and Gen. Porro declined the war portfolio.

In 1911 the Italo-Turkish War broke out. In the course of the war only two classes of reservists were called up, and as a result the units which were mobilized could not fill up with their own reservists. They were brought up to strength with men belonging to classes already under arms, and taken from units remaining in Italy, whose strengths were thus reduced to a miserably low level. Owing to the notable deficiency of the material detailed for mobilization the same system had to be followed in order to equip and refurnish the mobilized units. As a result the stocks in Italy were quickly reduced to a level quite inadequate for general mobilization. Little was done subsequently to fill the gaps, so that these remained.

*The Army in August 1914.*—The situation of the Italian army at the beginning of Aug. 1914 was as follows. Its financial resources were very limited. The estimates for the year 1914-5 provided 428 million lire (£17,120,000) which included not only ordinary maintenance expenses, but extraordinary expenditure for the rearmament of the artillery, for fortifications, etc.

All citizens were liable to military service for 19 years, from the 20th to the 39th year. They were divided into three categories, and only those belonging to the first category underwent the full term of service (two years). Men of the second category received a few months' instruction. Men of the third category received no instruction at all, and were destined for "third-line" service, even if they belonged to young classes. At the outbreak of war in 1914, owing to the large proportion of recruits yearly passed to the third category, there were in Italy, out of the total number of those of military age and fit for military service, only 1,400,000 men who had received military training. The rest, some 1,600,000 men, had received no military instruction of any kind.

The whole number of citizens liable to military service was divided, mainly according to age, between three organizations: permanent army, mobile militia, and territorial militia. The permanent army was composed of units existing on the peace basis. In peace-time it was composed of professional officers and non-commissioned officers, and of men of the first and second categories.

The force on the estimates for the financial year 1914-5 consisted of 14,000 officers and 275,000 men. The number of permanent officers was insufficient even for peace requirements. Reserve officers were taken from among the recruits of the levy who had passed certain examinations and who applied to serve as officers. They underwent regimental courses, and those taken completed their service as officers. Permanent and reserve officers together fell short by 13,000 of the number required for general mobilization. The greatest shortage was among the artillery officers, who could only total 56% of the number required, and the sanitary services, who were more than 50% short. Professional non-commissioned officers were almost entirely lacking. The law passed in 1910 in the hope of securing an adequate supply had not had the result hoped for. Most of the few who had adopted the army as a career were employed on special service outside the units.

Strengths were very low, so that the smaller units had barely sufficient troops to assure the performance of the ordinary everyday duties of barrack or field life. The troops, and especially the infantry, were continually employed in police duty; units were often split up into small detachments; drafts had to be furnished for Libya. In the circumstances it is easy to understand how complete and systematic training was impossible. Combined training of all arms was out of the question for a great part of the army, the troops of the various arms being stationed in such a way that whole divisions had neither cavalry, artillery nor engineers in their districts.

Owing to the low strengths, the units of the permanent army, in order to reach a war footing, had to incorporate a large proportion of reservists. As the trained reservists of each class were relatively few in number, many classes of reservists had to be incorporated on mobilization. In this way the units had to be completed with men of once older and less recently trained than was the case with the armies of France and Austria-Hungary. Complete mobilization in Aug. 1914 would have meant calling up no fewer than 13 classes.

The mobile and territorial militia units were intended to be formed at given centres, on mobilization, from reservists only. The number of these units and their character was to be decided according to requirements, by royal decree. The mobile militia was designed to operate with the permanent army, but to perform more modest duties than the permanent units. In order to facilitate its organization in case of need, it was decided in 1910 to maintain in peace-time, attached to every line regiment, Alpine battalion and field-artillery regiment, a permanent mobile militia nucleus, to fill up with reservists in case of war and so form the new units. But in 1914 many of these nuclei were not yet formed, and the others were at such low strength as to constitute a mere pretence. Mobile militia units were very rarely embodied for training in peace-time, so that, everything considered, it would have been necessary to improvise the whole organization. In the case of the territorial militia, destined for use on lines of communication or for duty at home, there was still less preparation; units were practically never embodied in peace-time.

Armaments were deficient both in quality and quantity. The infantry had an excellent rifle (1891 model), but the reserves and the output of the factories were not sufficient to meet the probable requirements of war. Machine-guns were almost entirely lacking. Only a few regiments had one section of two guns. Many artillery regiments were still armed with the old "krupp" gun. About 100 batteries had been armed with the new "rigid" 75-mm. Q.F. (1906 model), but before rearmament was completed it had been decided to adopt a new pattern (Depot 75-mm. 1911 model), and these were not yet ready. A considerable part of the mountain artillery was also unprovided with a quick-firing gun. The programme of 1910, providing for 40 batteries of heavy field artillery, had not been completed. Twenty-eight 4-gun batteries of 149-mm. field howitzers were all the heavy field artillery available. The siege train consisted only of a few big guns and 134 medium guns, generally of an obsolete pattern. The supply of ammunition was scanty. Motor transport was deficient.

The supply of uniforms, equipment, material for artillery and engineers, as well as for sanitary services, was lacking in quantity and quality. To sum up, the condition of the Italian army at the outbreak of war was as follows. The permanent army was lacking chiefly in instruction, machine-guns, heavy field artillery, siege train and material for air warfare. Strengths were very low, and the army had to mobilize with a very high percentage of reservists. Officers, both active and reserve, were too few, and there were scarcely any permanent non-commissioned officers. The units of mobile and territorial militias had to be altogether improvised, with the same bad results—but on a larger scale—as in the case of the permanent army. There was an enormous deficiency of animal and mechanical transport, of ammunition and of material of all kinds.

*The Neutrality Period (Aug. 1914-May 2, 1915).*—Up to May 2, 1915, when Italy joined in the war, an intense activity was displayed to make up the deficiencies of the army and enable it to meet with success its traditional foe. Rapid courses for officers were established in the recruiting-schools whereby the number of subaltern officers required to meet the immediate needs of the mobilized army was obtained. On Aug. 1, 1914, three classes were with the colours, those of 1892 and 1893—the two levies in course—and the 1891 class which had been recalled for service. On Aug. 8 the 1889 and 1890 classes were called up; on Sept. 7 the young 1894 class, and in Jan. 1915 the 1895 class. Thus the force under arms was 700,000 men. Other classes were called up later on, but with certain limitations as to categories, employment, etc. Reservists were not called up by public notice but by individual summons. Thus existing units were strengthened and new ones formed. Progressively, all the army, army corps, and divisional commands were formed side by side with the territorial commands already in existence. The latter continued to discharge their duties with the staff allotted to them for the period of the war. Provision was made with regard to staff and material required for the establishment of the principal offices charged with the various services.

Several regiments of the permanent army, provided for by the 1910 programme but not yet formed (chiefly field artillery), were organized. The majority of the mobile militia units provided for

were formed, with this important innovation that, instead of incorporating the comparatively old reservists, they were formed of levy men and young reservists, viz. with the same elements as the permanent army. This measure practically meant the suppression of the mobile militia, especially as the reservists destined formerly to the militia were assigned indiscriminately to all first-line units. Finally, the air-service units were, one may say, actually created.

The number of machine-guns and of small and medium calibre guns was increased, and the conditions of the siege train were improved to some extent. Means of transport, ammunition, and sundry other material were greatly increased by bringing up to a maximum the output of the military factories and by placing big orders both at home and abroad. In this way the most striking deficiencies of pre-war times were as far as possible made good.

But this was not all. From the very beginning of the neutrality period units were stationed along the frontier "in advanced occupation," and later on were grouped together under commands of the larger units which had been formed in the meantime.

It may be said, therefore, that when mobilization was officially announced (May 23 1915) a large portion of the army was already mobilized and assembled at the frontier. The mobilization of auxiliary services was, however, much belated in comparison with that of the combatant troops. This was due to causes connected with *matériel* as well as to the fact that the reservists detailed to such services could not be called up at so early a date. The mobilization plans existing in 1914, which presupposed conditions of forces and *matériel* quite different from those in which the army actually found itself, had to be modified substantially during the neutrality period. At the same time the troops underwent a continuous and intense training which remedied in part former deficiencies, especially among the reservists, and imparted the first lessons of the war which had already been fought for months on the Allied fronts.

Notwithstanding all this, in May 1915 the Italian army was not yet in an ideal condition as regards numbers and *matériel*. There were still serious gaps in the number of officers, in the supply of machine-guns and of artillery, as well as in the engineers, the Air Service, etc. The responsibility, however, of this state of things cannot attach to those who reorganized the army during the neutrality period; for they had not only to prepare, in many cases they had to create from nothing, the state in which the army had been left for so many years could not be remedied in ten months.

From May 1915 to November 1918.—The momentous work accomplished during the neutrality period did not cease when the war began, but continued in ever-increasing proportions while the army was engaged in fighting. The military authorities, efficiently supported by Government and nation, not only succeeded in filling up the gaps caused by losses and in remedying the deficiencies shown by the army in 1915, but strengthened it in men, weapons and material, and formed numerous new units and special troops instructed in the use of modern means of warfare. The magnitude of the effort on the part of army and nation appears more evident when one takes into consideration the enormous loss of men, animals and material which Italy sustained during the retreat of Oct. 1917 (Caporetto), and which had to be covered most rapidly. In that unfortunate event her army lost in guns 1,200 pieces, 300,000 men, 70,000 horses and mules, 3,100 guns (among which are two-thirds of all her heavy guns and half of the medium calibre), 1,700 trench mortars, 3,000 machine-guns, 2,000 machine-pistols, about 1,000,000 rifles, 22 aviation parks, 1,500 motor lorries, an enormous number of motor-cycles, etc. It follows that, when examining the data relating to the Italian army in Nov. 1918, it must be borne in mind what that same army had lost a year before. It can then be realized that Italy's effort has been a double one and that her army has to a great extent been formed twice.

According to pre-war provisions, the Italian army consisted of 19 classes. During the war, however, by calling up the younger classes and keeping the older ones, the number of classes with the colours was increased. At the moment of the Armistice the army included 27 classes (from 1874 to 1900). The oldest men were 44 and the youngest 18 years old. These classes gave a total of 5,200,000 men, who at the beginning of Nov. 1918 were made up as follows:—2,500,000 in the army operating in Italy, in the Balkans and in France; 1,200,000 belonging to units, and detailed for services, in the country; 1,500,000 losses (killed, discharged for wounds or sickness, prisoners). During the war no account was taken of the distribution of men as fixed by the old law in 3 categories and 3 army lines; all the men formed one single mass, and were distributed as follows:—in the war zone, 21 classes, that is, men from 19 to 39 (these classes were detailed, according to age, to the first line, to the services of the first line, to the second line and to the services of the second line); on service between the war zone and the country (lines behind the army), 3 classes, that is, men of 40, 41 and 42; in the country, 3 classes, that is, men of 43 and 44 and recruits of 18 who were being trained for service. The provisions which contributed principally to increase the number of drafts from each class were the adoption of a lower standard of physical fitness for military service and the consequent revision of all those who in the years preceding the war had been declared unfit for service.

The supply of drafts was provided for in the following manner. Up to the beginning of 1917 men called or recalled to colours, or

returning after medical treatment, were instructed or assembled in the depots from whence they were posted direct to the fighting units. At the beginning of 1917 each infantry brigade was given a reserve battalion from which gaps in the battalions of the brigade were filled up. The reserve battalion was, in its turn, replenished by march units detailed in the war zone (battalions, regiments, brigades) which received men from hospitals, etc., or from the interior of the country. During the last year of the war matters were so arranged that the men, however restored, returned to their own unit through the above-mentioned channel. This system was applied also to the Bersaglieri, to the Alpine troops, and to the infantry machine-gunners. The supply of drafts to other arms and to the various services continued to be secured under the system in force previous to 1917, that is, from the depots in the country. The scarcity of officers, especially of experience, with which the army entered the campaign, was continually aggravated by losses, and was felt during the whole period of the war. The gaps in the higher grades were filled by promotion, and the Italian army soon secured a prominent place among the belligerent armies in respect of the youthfulness of its generals. A certain number of battalion, company or battery commanders were taken from the cavalry officers. Vacancies in the lower grades were filled by means of rapid courses with the corps, the big units, and the recruiting schools in the country. Towards the end of the war only the latter system of recruiting was resorted to, and participation in the courses, which was first voluntary, became compulsory for all those who had gone through a certain curriculum of study.

When the army began its campaign it consisted of 14 army corps, 25 divisions of infantry, 4 divisions of cavalry, all in Italy. Its maximum strength was reached in Oct. 1917 with 26 army corps, of which one was in Albania; 65 divisions of infantry, of which 2 were in Albania and one in Macedonia (the Macedonian division consisted of 4 brigades and had therefore the strength of a corps); 4 divisions of cavalry. At the end of the war the army consisted of 2 army corps, of which one was in Albania and one in France; 57 divisions of infantry, of which 3 were in Albania, one in Macedonia and 2 in France; 4 divisions of cavalry. The army corps were grouped in a number of armies which increased from 4 at the beginning of the war to a maximum of nine.

The infantry strength at the beginning of the war was 560 battalions; on Oct. 1 1917 it was 800 battalions; on Oct. 1 1918 it was 700 battalions. The infantry battalion at the beginning of the war consisted of 4 companies, or 1,000 men, armed only with rifles. The few machine-guns available had been allotted to the regiments, generally 2 guns per regiment, rarely four. At the end of the war each battalion consisted of 3 companies of rifles (each with 2 machine-pistols), one company of machine-gunners (with 8 heavy machine-guns), one section of bombardiers (with 4 Stokes mortars, or 4 torpedo mortars), one section of sappers. The total strength of the battalion was 780 men.

While each battalion was transformed, each regiment was allotted a section of 37-mm. guns and a section of flame-ejectors.

Each brigade received two companies of heavy machine-guns, while four were assigned to each division. Taking into account only the heavy machine-guns, the infantry started the campaign with about 700 machine-guns. On Oct. 1 1917, these had increased to 7,000, and on Oct. 1 1918, to 12,000. In 1916 special Alpine battalions were formed, all consisting of men on skis, clothed and equipped in white and organized so that they could act independently, but they were not given many opportunities for action on skis. In 1917 assault groups were formed consisting of "arditi"—young and very active men who had undergone a most intense and severe training in gymnastics, bomb-throwing, and marching behind artillery or machine-gun barrage. These groups formed a splendid and characteristic attacking force used chiefly for surprise actions and desperate raids. Each group was of practically the same strength as an infantry battalion, but had a larger number of machine-guns and machine-pistols, and a few flame-ejectors. The "arditi" were armed with carbine, dagger and hand grenades. Each army corps had its own assault group and in 1918 a special army corps consisting exclusively of "arditi" was formed. In the same year each infantry regiment formed its own assault platoon (*plotone d'assalto*). During the war the infantry formed 17 groups of auto-machine guns each consisting of 4 or 6 guns and 5 companies of motor machine-guns each having 6 guns. No tank units were formed because the nature of the Italian front did not call for their use.

The most important transformation undergone by the cavalry during the war was the dismounting of two divisions which were used on the Isonzo and Carso fronts from the spring to the end of 1916; later on these divisions were mounted again. In the earlier stages of the war the cavalry supplied its machine-gun sections to the infantry. With its surplus reservists it furnished afterwards dismounted machine-gun companies which were used at the front.

In May 1915 the field artillery was the best armed among the different special corps and, therefore, underwent less and minor modifications. At the beginning of the war there were 360 batteries of 4 guns, on Oct. 1 1917 there were 440 batteries of 4 guns, on Oct. 1 1918 there were 490 batteries of 4 guns. No change was made with regard to the guns—the 75-mm. 1906 model and the 1911 model of the same calibre. Both guns were of the deformation pattern. The



1917 model had a carriage which when in position opened into two, allowing of important changes of target without moving the gun. This was a great advantage in view of the broken nature of the ground on the Italian front. Guns were drawn by animals, but at the time of the Armistice there were two regiments with guns on motor carriages. The mountain artillery and mule batteries were both supplied with light dismantlable guns carried on mules. At the beginning of the war the mountain batteries, served by numerous men and animals and abundantly equipped, were armed with the modern 65-mm. gun and employed in the Alpine districts, generally remaining in position; while the mule batteries, much less complex than the others, were armed with the rigid 70-mm. gun, and used in the plains or in hilly country, accompanying the infantry. Gradually, however, these batteries were equipped with the 65-mm. gun and the difference between the two kinds of batteries disappeared. In 1918 they had become of the same type. When Italy entered into the war there were 60 mountain batteries of 4 guns, and 20 batteries on mules of 4 guns. On Oct. 1 1917 there were 90 mountain batteries of 4 guns and 80 batteries on mules of 4 guns. On Oct. 1 1918 there were 170 batteries of the single type.

At the beginning of the war the heavy artillery was so scarce that it could not be assigned to any army corps, but was scattered, sometimes in single batteries, along the more important sectors of the front. It was armed with the 149 A howitzer, deformation pattern, with animal transport. Later on it was furnished with 105-mm. guns, also drawn by animals, and with 102- and 105-mm. guns drawn by motors. This innovation together with an increase in the number of 149-mm. howitzers made it possible, at the end of 1917, to slot to each army corps a mixed group of 149 A howitzers and of 105-mm. guns (two groups of three batteries) drawn by animals. All the groups drawn by motor and some of the others were left at the disposal of the supreme command. Towards the end of the war a group of three batteries of 149-mm. howitzers was assigned to each infantry division. The heavy field artillery consisted, on May 24 1914, of 30 batteries of 4 guns; on Oct. 1 1917, of 200 batteries of 4 guns; on Oct. 1 1918, of 280 batteries of 4 guns.

At the outbreak of the war the siege train was absolutely insufficient, both in quantity and quality. This state of affairs was improved by transporting to the front the majority of the guns—mostly of ancient pattern—belonging to fortresses, and by placing big orders with home factories. Thus the number of guns was increased and the obsolete batteries were replaced. At the same time the batteries were supplied with motor tractors. From the beginning of 1917 a well-supplied park of tractors was formed. After Caporetto, where a great portion of the old material was lost, the guns were replaced by modern guns made in Italy and in the Allied countries, and new complete permanent groups of guns of the same type were formed, while previously these groups were variable. The principal types of siege artillery in use at the end of the war were guns of 381, 355, 352, 149 and 120 mm.; howitzers of 305 and 152 mm.; mortars of 260 and 210 mm. Besides these, smaller calibres of antiquated patterns were used as fortress artillery. At the outbreak of the war the siege artillery consisted of 40 batteries; on Oct. 1 1917, of 750 batteries; on Oct. 1 1918, of 830 batteries. The siege batteries of big and medium calibres had from 2 to 6 guns each; those of small calibre had 8. On Oct. 1 1918 the total number of big- and medium-calibre guns was 2,350.

There were no anti-aircraft guns at the beginning of the war, and for some time field and mountain guns were adapted for use as anti-aircraft artillery. Later, batteries of 75-mm. guns mounted on motor-cars were formed, and the defence against enemy raids was organized. The anti-aircraft artillery consisted of 100 guns on Oct. 1 1917, and 130 on Oct. 1 1918.

Trench mortars (*bombarders*) were a creation of the war, their original object being to destroy wire entanglements by their curved trajectory and heavy bursting charge, and they proved most successful at the battle of Gorizia in 1916, after which their number and efficiency were greatly increased. During the retreat of Caporetto the bombardiers had to abandon, for lack of transport, nearly all their mortars and they were, therefore, temporarily grouped in a division which fought with the infantry; but as new material became available their battalions were reorganized. The principal mortars used were the 58 A, 58 B, 240 C, 240 L and 240 LA, formed into batteries or groups. On Oct. 1 1917 the batteries numbered 200 and as many autonomous sections; each consisted of 6 to 12 mortars.

To sum up, the Italian artillery was enormously strengthened, from the beginning of the war onward, in number and quality, of guns and by the formation of new specialties. Its organization was also improved. The campaign was entered into with a little more than 500 batteries, that is, less than one battery for each infantry battalion. On Oct. 1 1917, there were nearly 2,000 batteries, or 2½ batteries per infantry battalion. During the retreat of Caporetto 3,500 guns and 1,700 bomb-mortars were lost (something over 1,000 batteries). Nevertheless, on Oct. 1 1918 the army had more than 2,400 batteries.

The corps of engineers also was increased in numbers and transformed during the war. The sappers at the outbreak of hostilities were formed into companies; each infantry division had one company with a pontoon section and a telephone section. Later on battalions of sappers were formed of 3 companies each (one of which

with pontoon section), and a battalion was assigned to each infantry division, other units doing telephone service. On May 24 1915 there were 42 companies, on Oct. 1 1917, 72 battalions (223 companies), on Oct. 1 1918, 78 battalions (234 companies).

During the war the following special corps were formed:—telepherists; motorists detailed to the numerous drilling-machines used on the front, for digging caves, trenches and ways of communication in the rocky districts; gas specialists, whose chief duty was to examine and make experiments on the use of gas and the means of protection against it; flame-throwers, or detachments furnished with heavy flame-ejectors of position.

One may say that the aeronautical service, especially as regards aviation, was created during the war, at the beginning of which the army had only 24 squadrons of aeroplanes with about 60 machines fit only for observation purposes. Later on, thanks to the enormous increment of the home industry, the number of the machines was increased, and different groups for raids, chasing and observation were formed. In 1918 there were 51 groups with 1,400 machines. The balloon parks increased from 10 to 39. Airships varied as to type; but their number was always limited to six.

The medical service consisted originally of only 800 medical officers of the permanent army. Numerous officers of the reserve were drafted and new officers commissioned so that the total number reached 9,100. Field and other hospitals allotted to the fighting units increased from 300 to 500, to which should be added those of the Red Cross and of the Knights of Malta, as well as the up-to-date surgical and other establishments scattered along the front. Trains fitted for the transport of sick and wounded were increased from 36 to 74. Medical establishments within the country rose from 75 to 1,500 and the number of beds from 90,000 to 400,000.

Motor transport was enormously developed during the war, in consequence not only of the ever-increasing requirement of the war operations but also of the deficiency of animals. Motor traction was used for artillery, camp kitchens, pontoon equipment, etc. On Oct. 1 1918 the officers numbered 3,000, men 130,000.

Losses.—The first preliminary calculations of the losses suffered by the Italian army during the World War made immediately after the Armistice gave the following results in round figures:—Dead, 460,000, of which number 330,000 died on the battlefield or in consequence of wounds, 85,000 died of sickness, 45,000 died while prisoners; wounded, 900,000 and sick, 2,400,000, of whom 2,430,000 had resumed service, 300,000 were under treatment and expected to recover, 570,000 were invalided and permanently unfit for service.

The severest losses were sustained in 1917. The other years followed in this order: 1916, 1915 and 1918. The number of dead given corresponds to 1.27 % of Italy's total population in Jan. 1915 (36,000,000). Subsequent more accurate calculations proved that the actual losses had been underestimated. Senator Giorgio Mortara in his *Prospettive economiche*, published in 1921, quotes the following figures:

Killed on the battlefield	317,000
Died in hospital of wounds	51,000
Died in hospital of sickness	106,000
Prisoners who died of wounds	10,000
Prisoners who died of sickness	80,000
Total	564,000

This gives a percentage of dead to population of 1.56.

If one adds to the above total 25,000 released sick prisoners who died during the period of demobilization, and 62,000 who died of disease during the same period, the number of deaths rises to 651,000.

A revision and control of data dealing with losses was in 1921 being attended to, but the partial results already then known led to the belief that the first set of figures given was far inferior to the reality, and that even those given by Senator Mortara would have to be increased rather than diminished.

Demobilization.—On the cessation of hostilities the army began the reduction of its forces to something approaching pre-war strength. Demobilization could not be immediate or rapid owing to the necessity of keeping sufficient troops on the Armistice line and in foreign territories; of having many troops under arms in the country to repress the disorders likely to occur after such a war; of regulating the discharge of troops in accordance with means of transport available, taking into account also the probability of emigration on the part of some of the men discharged and the possibility of employment at home for others. It was also advisable to keep numerous units in the redeemed territories to employ them in urgent works of reconstruction. These and other considerations imposed a gradual demobilization of men as well as of animals and material. Demobilization involved not only a reduction but also a transformation inasmuch as the army had to be organized on lines different from those of 1914 and in accordance with the lessons of the war.

The older classes of reservists were discharged first. The men were given an insurance policy, a parcel of multi clothes or a corresponding sum of money and their fare to return to their residence in Italy or abroad. Officers were discharged after the men of their class. Medical officers especially were kept in the army to attend on wounded and sick men and prisoners returning from internment. By the end of June 1919, 14 classes had been discharged as follows:—



classes 1874 to 1876 in Nov. 1918; classes 1877 to 1884 in Dec. 1918; classes 1885 and 1886 in March 1919; class 1887 in April 1919. The 1900 class—which was the last called up during the war and which had not fought—was discharged on leave and called up again at the end of 1919 and the beginning of 1920. With the discharge of these classes, and with that of other special categories of the younger classes, the total number of men with the colours, which in Nov. 1918 exceeded 3,500,000, was reduced on July 1 1919 to about 900,000, of whom 72,000 were in the colonies, 54,000 in Albania, 27,000 in Macedonia, 9,000 in Asia Minor, 7,500 in France, and 2,000 in Russia. By the same date 225 generals and 76,000 other officers had been discharged.

During the latter part of 1919 nine other classes were discharged, as follows:—class 1888 at the end of June, class 1889 at the end of July, classes 1890 to 1892 at the end of Aug., classes 1893 and 1894 at the end of Sept., class 1895 at the end of Oct., class 1896 at the end of December. Immediately afterwards men belonging to the pre-war second and third categories of classes 1897 to 1899 were discharged, so that at the beginning of 1920 the Italian army consisted only of men of the first category of 1897, 1898 and 1899 classes. At the same time 130,000 reserve officers out of the 165,000 in service at the time of the Armistice had been discharged. The principal reductions in the different units of the army up to the beginning of 1920 consisted of the breaking-up of 5 commands of army, 21 commands of army corps, 45 commands of infantry division, one command of cavalry division, 31 infantry brigades, 6 brigades of bersaglieri, 49 Alpine battalions, 12 squadrons of cavalry, 180 field batteries, 80 mountain batteries, 105 heavy field batteries, 600 siege batteries. All the men of the 1897, 1898 and 1899 classes were discharged in Feb. 1921, when only the 1900 and the 1901 classes (the latter had been called up in Nov. 1920) were with the colours. By this date the last men who had fought in the World War had left the army.

#### VI.—UNITED STATES

In 1911 the actual strength of the U.S. regular army was 4,888 officers and 70,250 men, of whom 56,753 officers and men were stationed in the United States. Deducting the coast artillery, there was left, in the United States, a mobile army of only 31,850 officers and men. This small force was distributed among 49 army posts in 24 states and territories with an average strength of 700 men to each post, only one post having a capacity for a brigade. The result was a regular army extraordinarily expensive to maintain, the separate units of which had no organization higher than the regiment. There was no opportunity for manoeuvres on a large scale, little opportunity for the joint training of the several arms, and no practical experience for the officers of the staff-work and leadership necessary to the handling of larger commands. A partial concentration of troops on the Mexican border in 1911 gave the U.S. army its first opportunity for a division manoeuvre.

Under the Act of 1901 the National Guard of the different states had been assimilated to the regular army in organization and equipment, and was receiving financial assistance from the Federal Government in the shape of equipment and pay for manoeuvres and the loan of officers from the regular army for training. In 1911 this force was in far better condition than it had been at the outbreak of the Spanish-American War (1898), but it was still locally organized, was made up of men whose military association and activity were merely an incident added by interest and preference to their ordinary civilian occupation, and was affected by traditions and associations based upon state rather than national service. In 1911 the reported strength of the National Guard was 117,980 officers and men, and an Act of Congress authorized the President to increase the army establishment so as to provide 200 officers of the active list of the regular army for duty as inspectors and instructors of the organized militia and National Guard.

**Reorganization of 1916.**—Successive Secretaries of War had vainly urged upon Congress the necessity of a reorganization of the regular army on the basis of larger tactical units. In June 1916 there was finally passed and approved the bill known as the National Defense Act. This provided for an increase of the regular army to a total not to exceed 11,450 officers and 175,000 troops of the line, including the Ordnance Department, 42,750 non-combatant troops and unassigned recruits, and 5,733 Philippine Scouts, in all about 235,000 officers and men. The number of regiments was to be increased to 65 of infantry, 25 of cavalry, 21 of field artillery, 7 of engineers, with an additional 2 battalions of mounted engineers. These increases were to be carried out by July 1921 and five annual increments, but the President was authorized, in case of emergency, to put them into

immediate effect. The general officers of the line were increased in number from 7 to 11 major-generals and from 17 to 36 brigadier-generals to provide the necessary general officers for the contemplated divisions and brigades and higher staff appointments. The period of enlistment in the regular army was altered to 3 years with the colours and 4 in the reserve. The National Defense Act also provided for bringing the organized militia of the several states into a single national guard, the entire expenses of which were assumed by the Federal Government. It was estimated that this force would ultimately reach in peace-time a strength of 17,000 officers and 440,000 men of all arms, so apportioned that when assembled at the call of the Government it would constitute 16 divisions. The Act further authorized (a) an Officers' Reserve Corps, to be selected, trained and commissioned in time of peace for use in war only, up to and including the grade of major, and (b) an Enlisted Reserve Corps, specialists for the technical departments of the army, to be recruited in time of peace for use in war only.

**The General Staff Corps.**—Before 1903 the American army had possessed no general staff. Since the early history of the country there had been a commanding-general of the army and a system of semi-independent War Department bureaus, loosely coordinated either with each other or with the line of the army, and there had always existed uncertainty and dispute as to the respective functions and authority of the Secretary of War, the commanding-general and the bureaus. In Feb. 1903 a Congressional Act abolished the office of commanding-general and created a General Staff Corps, to be composed of 45 officers, with a chief-of-staff who, under the direction of the President and the Secretary of War, was charged with the supervision of all troops of the line and all the War Department bureaus. In actual practice, however, the separate and combined jealousies of the long-established bureaus, and still more the initial lack of training and experience in the first officers detailed to the new general staff reduced the latter almost to complete uselessness and impotence. Nevertheless, the traditional national distrust of anything savouring of a military oligarchy caused Congress in 1912 to decrease the number of general staff officers to 36. The National Defense Act raised this number to 57 to be reached, however, only in five annual increments, and with the proviso that not more than half of these officers should be "at any time stationed, or assigned to or employed upon any duty in or near the District of Columbia."

In connexion with the army legislation of 1916 Congress created also a Council of National Defense, to consist of the Secretaries of War, the Navy, the Interior, Agriculture, Commerce and Labor, with an advisory commission of 7 specially qualified citizens; and to this Council was committed the task of studying and coördinating the military, industrial and commercial resources of the nation in connexion with its defense.

The disorders in Mexico since 1911 had made almost continually necessary the patrolling of the long international boundary by the bulk of the regular army. In March 1916 a raid into U.S. territory by Villa had led to the calling-out of the National Guard and its concentration along the border, while an expeditionary force of regular troops under Gen. Pershing was sent into Mexico. In Feb. 1917 the expeditionary column was withdrawn and the National Guard organizations returned to their respective states. The close of this emergency, almost coincident with the entry of the United States into the World War, left the regular army with a large percentage of its men due for discharge because of expiration of their terms of enlistment and left the National Guard in the throes of a combined demobilization and reorganization.

**1917 to 1919.**—In March 1917 the actual strength of the regular army was 5,791 officers and 121,797 men, of the National Guard 3,199 officers and 76,713 men, a total of 207,500 officers and men. In addition there were 97,293 enlisted men of the National Guard who had not yet taken the oath of federalization. The General Staff Corps, though by this date composed of trained and competent officers, had a total strength of only 41 members, of whom, under the law, only 16 could be stationed in or near Washington. Soon after the declaration of war by the United States, April 6 1917, the evident and acknowledged military unpreparedness of the United States led to tentative suggestions from the Allied Powers that such forces as the United States had at its disposal be at least temporarily merged into the more experienced units of the Allied armies. But the Government in Washington considered that, in spite of popular enthusiasm, American sentiment would not tolerate any such absorption. Accordingly, the order appointing Gen. Pershing commander-in-chief of the American Expeditionary Force specifically charged him, while cooperating in all ways with the Allied military authorities, to "reserve the identity of the U.S. force." It was further thoroughly understood and agreed on by the U.S. authorities that the mission of the overseas force was to be an offensive one. Those two conceptions, maintained throughout the war, governed all war plans and activities of the United States both at home and abroad.

It was immediately decided, as a tentative programme, (a) to send overseas promptly a small but complete body of American troops, in the form of one tactical division to serve as a nucleus for the organization and training of American overseas troops and in order that some American troops might be put into the trenches at the earliest possible moment, and (b) to follow this by an expedition-

ary force of sufficient size, if the shipping situation permitted, to make American military participation an effective factor in the prosecution of the war. Accordingly, on May 28 1917 Gen. Pershing, with a small staff, sailed for Europe and in June the 1st Div. regular army, 12,261 men, accompanied by 2,798 marines, was embarked.

**Mobilization.**—On May 18 1917 there was passed and approved the Congressional Act known as the Selective Service law. It provided that, in addition to the regular army and the National Guard, there be raised for the emergency a national army, by selective conscription of men between the ages of 21 and 30, of which army the President was empowered to summon two units of 500,000 men each at such time as he should deem wise. The same Act removed, for the period of the emergency only, all restrictions as to the numbers and location of officers of the general staff. On July 3 the President called into service the entire National Guard and 16 divisional camps were established for their concentration and training. The first registration under the Selective Service law, June 5 1917, was carried out in the main by the voluntary efforts of citizens and gave a total of 9,587,000 registrants. The actual drafting into service was delayed by the necessity of waiting for the construction of the 16 divisional cantonments planned for the national army, and by the lack of equipment and especially of woollen clothing. The first draft, Sept. 1917, inducted into military service 296,678 men, and up to Dec. 1 1917 there had been drafted from this first registration 496,043 men. On Dec. 15 voluntary enlistments of men between 21 and 30 were discontinued. From that date also all registrants were arranged in five classes according to their importance to the economic interests of the nation and the support of dependents. The men thus placed in Class I, were first rendered liable for military service, and in the sequel the four "deferred" classes were never called upon. In May 1918 Congress provided that the quotas of the various states should be apportioned according to the number of registrants in Class I, instead of according to population. The total registered, including those coming of age during the operation of the scheme, was upwards of 10,481,000 men. Of these there had been, on Nov. 11 1918, inducted into military service by the draft 2,801,635, or about 25 per cent. In July 1918 it became evident that the then extended military programme would soon lead to the exhaustion of Class I. In order to prevent the industrial disturbance and economic hardships incidental to calls on the deferred classes, Congress provided for the registration of all males between the ages of 18 and 45, both inclusive, and made registrants liable to service in the navy and the Marine Corps as well as in the army. This registration, held Sept. 12 1918, yielded an additional total of 13,228,000 registrants, but owing to the close of the war these were never drawn upon. The following table shows, in round numbers, the recruiting from month to month:—

Month.	Drafted.	Voluntary Enlistments. All Ages.	Aggregate.
1917			
Sept.	297,000	24,000	321,000
Oct.	164,000	31,000	195,000
Nov.	36,000	46,000	82,000
Dec.	20,000	142,000	162,000
1918		Outside.	
		Draft Ages	
Jan.	23,000	41,000	64,000
Feb.	84,000	26,000	110,000
March	132,000	25,000	157,000
April	174,000	23,000	197,000
May	373,000	26,000	399,000
June	302,000	28,000	330,000
July	401,000	19,000	420,000
Aug.	283,000	11,000	294,000
Sept.	263,000	—	263,000
Oct.	107,000	—	107,000
Nov.	7,000	—	7,000

**Replacements.**—In April 1918 there were added to the 32 training-camps already functioning in the United States nine replacement camps of various arms. These were intended to supply the necessary replacements (British "drafts") for the overseas troops, calculated at from 10% to 25% a month, and to obviate the necessity of drawing upon divisions already organized and in training.

**New Officers.**—One of the most serious problems which confronted the War Department, in April 1917, was the securing of a sufficient number of officers. To meet this need a first series of 16 officers' training-camps was opened on May 13 1917. Officers previously commissioned in the Reserve Corps were required to attend and in addition some 30,000 selected voluntary candidates were admitted. In Aug. there were graduated from this first series 27,341 officers, a number sufficient to meet immediate needs. A second series was opened in Aug. 1917 and a third in Jan. 1918. The first two classes were essentially civilian in character and largely from the university element, and because of the need for officers of all grades commissions were granted up to the grade of colonel. The third class drew 90% of its candidates from the enlisted ranks of the regular army and

its graduates were commissioned as second lieutenants. These first three classes had supplied, to April 1918, a total of 57,307 new officers.

**War Department Organization.**—Gen. Pershing, who had been given the greatest latitude in the carrying-out of his mission, had very early established the general staff of the Expeditionary Force, selecting from the British and the French systems those features which seemed best adapted to the basic organization of the American army. But the War Department in Washington was in this matter dependent upon Congressional legislation. As the war progressed the system of separate and independent bureaus eventually and inevitably developed a condition of affairs which threatened to jeopardize the success of the military programme. Each bureau, absorbed in the sudden expansion of its personnel, and in its own problems of supply, concentrated its efforts on its own needs without reference in general to the requirements of other bureaus or services or of the army programme as a whole. It was not until May 29 1918 that a Congressional Act made it possible to provide for: (a) a redistribution of the functions of already existing bureaus; (b) the creation of certain new agencies and services made necessary as the result of the development and experiences of the army overseas; (c) the reorganization of the general staff into five main divisions in such a manner as to enable it to perform its proper functions of an effective central controlling agency.

**The American Expeditionary Force.**—The original tentative programme had contemplated in a general way the placing in France by the end of 1918 of approximately 1,000,000 men. Between July and Oct. 1917, after consultation with the Allies and a study by Gen. Pershing and his staff of Allied organizations, a more definite programme was drawn up. In order that the services of the rear might keep pace with the arrival of the combat troops this plan was divided into six phases and contemplated the placing in France by Dec. 31 1918 of 1,372,399 troops (consisting of 30 divisions, organized into 5 corps of 6 divisions each (4 combat, one training, one replacement), with 2 regiments of cavalry, the necessary corps troops, army troops, service of supply troops, and replacements. It was decided that the American combat division should consist of 4 regiments of infantry (of 3,000 men each, with 3 battalions to a regiment and 4 companies of 250 men each to a battalion); one artillery brigade, of 3 regiments; one machine-gun battalion; one engineer regiment; one trench-mortar battery; one signal battalion; wagon trains; and the headquarters staffs and military police. These with the medical and other units for each division made a total of over 28,000 or practically double the size of the French or German division. With 4 divisions fully trained a corps could take over an American sector with 2 divisions in line and 2 in the reserve, with the depot and replacement divisions prepared to fill the gaps in the ranks.

In July 1918 an extension of the original programme was adopted contemplating, by July 30 1918, 80 divisions in France and 18 at home, based on a total strength of the American army of 4,850,000. A further extension, approved Sept. 3 1918, was communicated to the supply departments. It provided for an army of 4,260,000 (100 combat divisions) in France, with 1,290,000 (12 combat divisions) in the United States, a total of 5,550,000 to be reached by June 30 1920. Up to the signing of the Armistice the troops were being transported to France in accordance with the July 1918 programme. The needs of training in the overseas forces, and especially of first constructing the necessary facilities for the services of the rear for an independent American army, at first greatly delayed the entry into line of American troops. On Dec. 31 1917 (there were in France only 176,665 American troops and but one division had appeared on the front. On Nov. 11 1918, 40 American divisions had reached France (7 regular arm troops represented 31% of the ration strength of the Allied forces in France and held 27% of the length of the western front. Toward the later stages of the war 2 American divisions cooperated with the Australian corps; 2 divisions assisted the French IV. Corps; and 2 divisions fought with the French VI. Army in Belgium. During the Meuse-Aargonne battle 29 combat divisions operated on the American front. Nov. 20 1918 Gen. Pershing, after estimating losses, reported in France 1,338,169 combatant troops. Of the 40 combat divisions which had arrived in the infantry personnel of 10 had been used as replacement troops, leaving at that time in France 30 divisions organized into 3 armies of 3 corps each. Of these forces approximately 44% had been transported overseas in the American, 51% in British, 3% in Italian and 2% in French ships.

**Losses and Casualties.**—To Nov. 18 1918 the losses were: killed in action, 35,556; died of battle wounds, 15,130; of other wounds, 5,669; of disease, 24,786; total deaths, 81,141; wounded, 179,625; missing, 1,160; prisoners, 2,163. Total casualties, 264,089. Of the wounded about half suffered very slight injuries.

**Other Fronts.**—In addition to its military effort in Europe the United States remained throughout the war under the necessity of maintaining its patrol organizations along the Mexican border. The bulk of its cavalry with some artillery was thus employed. In Sept. 1918 an expeditionary force of 10,000 was sent to Siberia in cooperation with other Allied troops. A small force of 5,000 men sent with the Allied expedition to Murmansk formed part of the A.E.F. organization. One U.S. regiment served in Italy.

Growth in strength and variety of services between March 1917 and Nov. 1918 (in round numbers.)

Service.	Old Army March 1917.	New Army Nov. 1918.
Infantry	85,000	974,000
Engineer	3,000	394,000
Field Artillery and Ammunition Train	9,000	389,000
Medical	7,000	300,000
Quartermaster	8,000	228,000
Coast Artillery	21,000	137,000
Ordnance	1,000	64,000
Signal	3,000	54,000
Cavalry	22,000	29,000
Air	none	202,000
Motor Transport	"	103,000
Militia Bureau	"	27,000
Chemical Warfare	"	18,000
Tank	"	14,000
In Training	"	549,000
All Other	31,000	185,000
	190,000	3,665,000

**Demobilization.**—The problem of demobilizing was simpler for the United States than for other countries. Pivotal or key men had not been withdrawn from industry nor had the man-power been drafted to the same extent. Moreover, since all units contained a fair proportion of men from all trades and commercial activities, it had already been decided to demobilize by complete units as they could be spared. A few priority exceptions were made in the case of coal-miners, railroad men, certain post-office employees, etc. Demobilization of emergency units still in the United States began immediately. The chief difficulties were met in the regular army, where only a few thousand men were still serving under enlistment contracts entered into prior to 1917, and in the National Guard, where recruits and replacements had infiltrated every organization with drafted men. As under these conditions rapid demobilization would have meant the disbanding of practically all organized military forces in the United States, authority was granted by Congress, in Feb. 1919, to reopen voluntary enlistments for the regular army and National Guard. To insure the return of all men as speedily as possible to their former places in the economic life of the nation, the general plan provided for the transportation of each man, previous to discharge, to the demobilization camp in or nearest to the state from which he had entered the service. For this purpose 31 former training-camps were utilized. On arrival in the United States, unless sick or wounded, the men were immediately distributed to their proper discharge camps. There each soldier, after a final physical examination and other routine processes, was discharged, paid and entrained for his home or place of entry. Men sick or still suffering from wounds or infectious diseases were not discharged until cured or otherwise provided for. The initial lack of American tonnage delayed for a time the return and discharge of the overseas troops, but between Nov. 11 1918 and June 30 1919 there were returned from France 1,610,074 men and officers, of which number 84% were transported in American ships. The record for the month of June was 434,786 men, the greatest number shipped across in any one month. In Nov. 1919 there had been discharged, in all, 179,800 officers and 3,236,266 men. The discharge of men in the ranks was practically completed on April 1920. (A. L. C.)

#### VII.—BALKAN ARMIES

(1) **Serbia.**—In 1911 the Serbian army consisted of 5 infantry divisions each of 4 regiments, one cavalry division, and special formations of mountain and siege artillery. The army thus comprised 20 infantry regiments of 3 battalions each, 4 cavalry regiments of 4 squadrons, 7 f. a. regiments (45 batteries f. a., 2 batteries horse artillery, 9 mountain and 6 how.), 2 battalions of siege artillery, 24 battalions engineers, a cavalry telegraph section. The *peace strength* of the army was 2,033 officers, 4,338 under-officers, 22,559 men. From 1901 the Serbian army was raised on the compulsory system, by which all able-bodied Serbs became liable for military service on attaining 21 years, and remained so till the completion of their 46th year. The first two years were supposed to be spent with the colours, though in practice this was reduced to one and a half, after which the soldier passed to the 1st line reserve for nine years. He then passed to the 2nd line reserve for six years, and to the 3rd line for the remainder of his period of liability. The yearly quota of recruits was during the years immediately preceding 1910 about 25,000.

The infantry was equipped with a 7-mm. Mauser with a range of 2,000 metres. Each man carried 150 rounds on his person. The artillery before the outbreak of the Balkan War was in process of being equipped with the modern French field gun (75-mm. field and 70-mm. mountain guns). The older weapons which were being replaced were the 85-mm. de Bange. There were no field howitzers, but there was a siege train with 12- and 15-cm. howitzers.

The *war strength* of the mobilized field army thus comprised 3 active infantry divisions, 5 divisions 2nd line reserve, 5 divisions 3rd line reserve, one Ersatz division of 1st line reservists approximating in composition to an active division. In addition the commander-in-chief had for his own disposal one cavalry division, one guard detachment (2 squadrons), one heavy field-artillery regiment, one siege-artillery regiment, some railway and balloon troops. The total mobilized strength, representing the maximum effort of the country, was about 260,000 men.

As a result of the Balkan War the 5 divisions of the standing army were increased by another 5 (the Kosovo, Vardar, Monastir, Shtip, and Ibar divisions), all formed from the new territory acquired. The artillery was also increased by 10 batteries. Owing, however, to the very short time of peace which elapsed between the close of the 2nd Balkan War (July 1913) and the outbreak of the World War, the reorganization which had been contemplated could only be carried out in part.

On being mobilized at the end of July 1914, when Austria-Hungary declared war, the Serbian army totalled about 350,000 men, and it was organized, now for the first time, in four armies of three divisions each.

(2) **Bulgaria.**—In 1911 the Bulgarian army was organized in 9 infantry divisions of 4 regiments (formed into 3 army inspectorates which on mobilization formed 3 armies), and 11 cavalry regiments. The army thus comprised, on a peace footing, 36 infantry regiments (each consisting of 2 battalions, one non-combatant company, and one machine-gun section), 11 cavalry regiments (each of 3 squadrons), 9 field-artillery regiments (each of 6 batteries), 3 mountain-artillery regiments (each of 4 batteries), 3 field-howitzer batteries, 3 siege-artillery groups, 3 pioneer battalions, a telegraph, pontoon, and railway battalion, one mechanical transport company, one cyclist company, one balloon company, 3 army service corps detachments, 16 frontier companies. The total strength of the army was 3,891 officers and 55,709 men. The army was raised on the compulsory service system. Every Bulgarian was liable to military service from his 20th to his 46th year. The classes were called up annually and a man normally served two years in the active army (or three in the case of the special arms), and then passed to the reserve until the completion of his 46th year.

The infantry were armed with the 8-mm. Mannlicher with a range of 1,100 metres. A few Russian Berdan rifles were to be found. Each man carried 150 rounds on his person. The cavalry had Mannlicher carbines; only the guard cavalry had lances. The artillery was mostly of French pattern: the 75-mm. Schneider-Creuzot field gun, 10.5-cm. field howitzer (Schneider-Creuzot), and 75-mm. Schneider mountain gun, with a few 12-cm. and 15-cm. Krupp and Creuzot howitzers.

On mobilization each of the 9 peace infantry divisions split into 2. Each of the 4 companies of the 72 infantry battalions expanded into a battalion. The 11 cavalry regiments, reinforced by mounted police, formed one cavalry division of 6 regiments, and the (infantry) divisional cavalry. An infantry division on a war footing thus consisted of 4 regiments of 4 battalions each; 2-4 machine-gun companies; 10 batteries of 4 or 6 guns; 2 squadrons cavalry; one howitzer battery; 2 engineer companies. The mobilized strength of the field army was about 350,000 men. In addition 72 battalions of older men (500 strong) were formed for garrison and L. of C. duties. There were thus about 400,000 men under arms.

After the Balkan War the permanent strength of the Bulgarian army was slightly increased, proportionately to the increment of population. A 10th division—the Aegean or White Sea Div.—was raised, and the army on a peace footing numbered 85,000 men.

In Sept. 1915, 10 divisions of 24,000 men each were mobilized according to plan, but as the World War progressed other formations were added. In 1916 an 11th Macedonian division was raised, mainly of Macedonians in the conquered territory of Serbia. Later a 12th division was raised, and towards the end of the war there were 14 divisions in the field. The system of splitting peace divisions into two, which had been followed in the Balkan War, had been dropped, but a division formed 6 regiments, instead of 4. A Bulgarian division of full strength was thus 24 battalions—24,000 rifles and 2 regiments of artillery. An order of battle published by the Bulgarian general staff on Sept. 15 1918—two weeks before the Armistice—shows a grand total of 877,000 men of all ranks under arms.

(3) **Greece.**—In 1911 an Act was passed which provided for the reorganization of the Greek Army. This reorganization contemplated 3 large divisions of infantry (27 battalions each), corresponding much more to army corps than divisions, a cavalry division, a heavy artillery regiment, and technical troops. At the outbreak of the Balkan War in 1912 the total number of units which took the field was: 44 battalions of infantry, 16 cavalry squadrons, 47 batteries of field and mountain artillery. These were organized into 4 (active) divisions, each consisting of: 2 regiments (of 3 battalions), and 3 machine-gun companies each; 2 battalions of evzones (rifles), one cavalry squadron, 9 batteries field artillery or mountain artillery, 2 companies pioneers. The remaining cavalry was formed into a cavalry division. In addition to these 4 active divisions there were also 3 or 4 reserve divisions, similarly constituted. The army thus mobilized had a combatant strength of about 120,000 and a ration

strength of about 185,000. The total number of men with the colours at the end of the war was 210,000.

The infantry were armed with the Mannlicher-Schonauer rifle 6.5 mm., or the French 11-mm. Gras rifle. The cavalry had lances, and carbines of the same pattern as the infantry rifle. The field and mountain artillery were armed with the 7.5-mm. Schneider-Creusot, though some of the mountain batteries had the 7.5-mm. Schneider-Danglis ("screw-gun"). The heavy artillery was all of old pattern.

At the conclusion of the Balkan War a thorough reorganization of the army was undertaken. By the end of 1914 the army was, on paper, organized into 5 army corps of 3 divisions each, an independent cavalry brigade of 2 regiments, and a regiment of fortress artillery and fortress engineers. A Greek corps thus consisted of the following: 3 infantry divisions (of 3 regiments and one group of mountain artillery), one cavalry regiment, one field-artillery regiment, one regiment engineers, medical and intendants units. The total strength of a corps was about 30,000 combatants. The artillery organization was somewhat peculiar. Infantry divisions were provided with only 3 batteries of mountain artillery, field artillery being retained as corps troops. There was practically no heavy field or siege artillery. On Bulgaria joining the Central Powers in Sept. 1915 the Greek army was mobilized as a precautionary measure. The total strength mobilized was about 150,000 combatants. When in June 1917 Greece joined the Allies, 3 divisions (about 20,000 rifles) were already in being at Salonika, and it was expected that 10 divisions would finally be raised to take part in operations on the Salonika front. By the Armistice there were actually (in Macedonia) 9 divisions (3 corps) of about 60,000 combatants in line. They had been practically entirely armed and equipped by the Allies at Salonika. They participated and gave a good account of themselves in the final offensive against Bulgaria in Sept. 1918.

(4) *Rumania*.—Under the Army law of 1908, amended in 1910, military service was universal, and lasted from the completion of the 21st to that of the 42nd year, 7 years being spent with the colours, 10 in the reserve, and 4 in the militia.

In May 1913 a new recruiting law increased the total length of service to 25 years—from the 21st to the 46th year of age. The new term included 7 years with the colours, 12 years with the reserve, and 6 years with the militia. In 1913, out of a pop. of seven and a half millions, Rumania took 0.66% as recruits, and the peace establishment of the army amounted to 1.17%, without counting officers or administrative staffs. It was intended to increase the number of recruits to 52,000 in 1914. The peace strength of the army in 1913 showed 5,069 officers, 979 officials, 5,476 retrained non-commissioned officers, 85,791 men. In connexion with the new recruiting law, it was also decided in May 1913 that the "army of operations" should consist of the active army (1st line) and the reserve (2nd line) while the militia (3rd line) was designed for employment in the interior of the country, as well as in rear of the army of operations. In 1913, before the mobilization against Bulgaria, the infantry consisted of 40 regiments, of which 32 had 3 and 8 had 2 field battalions to one Ersatz battalion. To each regiment there were one machine-gun section with 3 guns, 19 Jäger battalions, each with one field-artillery company; 8 reserve battalion cadres. In 1913 these would form, for war purposes as first-line troops: 40 infantry regiments of 3 battalions, 18 Jäger battalions, 12 frontier guard companies. The second-line troops would comprise 40 reserve infantry regiments of 2 battalions, and the third line 40 militia battalions. In war-time one machine-gun section (2 guns) would be formed for each first-line battalion. The armament of the line and reserve troops consisted of Mannlicher repeating rifles, mark 93, calibre 6.5 mm. The field artillery was being extensively developed up to the summer of 1913. By the summer of 1913 the artillery establishment had reached the following numbers: 10 artillery brigade commands; 20 field-artillery regiments, each of 6 field batteries and one Ersatz battery; 5 field-howitzer detachments of 3 field batteries and one Ersatz battery; one mounted artillery detachment of 2 batteries; one heavy howitzer detachment of 2 batteries; one mountain-artillery regiment of 4 batteries. In war-time 4 reserve field-artillery divisions of 3 field batteries were to be formed for the reserve divisions of the infantry. The artillery armament included 7.5-cm. Krupp quick-firing guns, mark 1904 for foot, mark 1908 for mounted batteries; 12-cm. Krupp light field howitzers, afterwards gradually replaced by 10.5-cm. field howitzers, and 6.3-cm. Armstrong mountain guns. For heavy (fortress) artillery in 1910 there were two regiments, each of 2 battalions of 3 and 11 companies respectively. By 1913 this arm had been increased by 3 companies.

In 1913, when Rumania mobilized in case of intervention becoming necessary against Bulgaria, the war muster of the field army included 6,500 officers and 373,500 men. There were, in addition, 45,000 men of the territorial commands in the interior of the country, and about 55,000 men not embodied. The total number called up was thus about 473,000 men.

In Aug. 1914 Rumania, in view of the political situation, successively called up all the men of the previous seven-year classes. In Oct., however, the Government decided for armed neutrality, and the army reverted to a peace footing. The strengthening of the army proceeded nevertheless at an increasing rate up to the time of Rumania's entry into the war. At the end of Aug. 1916 the total

war strength of the Rumanian army included 330-340 battalions of first- and second-line infantry, 80 battalions of third-line infantry, and 112 squadrons of cavalry, while the artillery of the field army included 768 modern guns. The total number of trained men available when Rumania entered the war in 1916 was about 860,000. Of these 700,000 men were taken for the field army, so that there remained for use as Ersatz troops 160,000 trained men in addition to about 150,000 not yet trained.

On Aug. 27, when Rumania declared war on Austria-Hungary, the mobilization and marching forward of the army had proceeded so far that the advance against Siebenbürgen immediately followed the declaration of war. Rumania put four armies in the field, one operating in the Dobrudja and three against Siebenbürgen. The field troops were formed into 23 infantry and 2 cavalry divisions. After the decisive defeat in Dec. 1916 the reconstruction of the army was seen to be a pressing necessity, and this was effected under a French military mission. The work of reorganization carried out by the French mission had excellent results. From July 1917 onwards the I. Army was again at the front. In the battles fought between the end of July and the middle of Sept. 1917, the army possessed an actually greater battle strength than when it entered the war.

### VIII.—THE GERMAN ARMY

In the four years up to the outbreak of the World War, intensified progress was made in the German army along normal lines, but in Aug. 1914 there began and continued an astounding military effort which in many ways differed from that which the peace-time system had led observers to expect. To attempt to understand that effort, therefore, one must return to fundamentals. General Ludendorff, in his *War Memories*, in saying that each of the various combat states produced good divisions and poor divisions, adds—"Württemberg and Baden had only good ones." In this judgment the Entente intelligence staffs, whose speciality was study of the opponent's quality, would concur. Yet in 1870 these two contingents had a very small share in victory, and in earlier times their troops, though figuring in many wars as components of this or that federal army, never won for themselves an outstanding reputation for high quality. On the contrary, these countries were the very home of the old German *Gemüthlichkeit*, and in the 18th century Burke quoted Württemberg as a model of a peacefully and constitutionally governed country.

In reality, two cultural waves, so to say, contributed to make the German army what it was: first, the tide of Germanic civilization which spread from the upper Rhine and Danube countries N.E. over the mountains and into the great plain of the Slavs, and secondly, the tide of Prussian "objectivity" and efficiency which in the 19th century set in in the reverse direction, from N.E. to S.W. And it can be said without forcing the facts, that the military quality of Germany was fundamentally soundest at those two moments in history when, in 1813, the sense of civilization and nationality worked for the first time strongly upon the hard "East-Elbians," and when in 1914-5 the spirit of business and duty imposed by these East-Elbians upon the peaceful S.W. made their inborn nationalism an effective instead of an ineffective thing.

The study of these currents is, of course, practically the same as the study of German history. But one thing may here be emphasized. No other basic hypothesis than that of continuing national characters can account for the fact that these two comfortable S. German states were awarded primacy in military quality by a Prussian commander-in-chief. Were it otherwise, the quality of the various contingents would simply have been measured by the length of the period during which their respective states had been subjected to the civil and military training of Prussia. Such a criterion has in fact been applied, but it proved false even in respect of the active army of peace-time. Nevertheless, as Prussian military ideas and methods provided the skeleton on which this spirit was made flesh, and which fortified the flesh against weakness, an objective account of the German army of the last war period must begin with a schematic presentation of that skeleton.

*Higher Formations in Peace*.—The growth of the Prussian-German military organization from 1815 to 1914 is shown by the accompanying Table A. (The Roman numerals indicate the corps to which a division belonged at the time considered. When

the corps numeral is in brackets, the division is attached to that corps as a third division.)

It must be premised that the corps numbers indicate territorial districts as well as military commands. The six "Brigade" districts of Prussia during the period of army limitation imposed by Napoleon became corps districts after 1815, and two others were added when for the first time Prussia acquired Rhine possessions adjacent to France. The annexations of 1866 produced three other Prussian corps and corps districts, and thereafter the course of evolution is sufficiently indicated in the table. After 1871, of course, all new districts were carved out of the existing ones. It will be seen from Table A that during the

organization of 1913 there had been bitter controversy—the general staff demanding five new army corps and the Reichstag conceding only two—and no fewer than 17 supernumerary regiments (more than the infantry complement of two army corps) were left ungrouped after the 20th and 21st Corps had been formed. These 17 were a fifth brigade and an eleventh regiment in the Guard, fifth brigades in the frontier corps regions 5th, 6th, 7th, 9th, 14th, and ninth regiments in the 2nd, 13th, 18th and 21st Corps.

There were, therefore, in the active army of 1914, 50 divisions (two Guard, 1-42, and 1-6 Bavarian) and 17 supernumerary infantry regiments.

TABLE A.—Growth from 1815 to 1914.

		Prussia 1815-60.	N. German Confed. 1867.	1871.	1880.	German Empire.		1900.	1912.
						1885.	1890.		
Prussia, 1815	1 Prussian Guard Div.	G	G	G	G	G	G	G	G
	2 Prussian Guard Div.	G	G	G	G	G	G	G	G
	1 Div.	I.	I.	I.	I.	I.	I.	I.	I.
	2 Div. East Prussia.	I.	I.	I.	I.	I.	I.	I.	I.
	3 Div.	II.	II.	II.	II.	II.	II.	II.	II.
	4 Div. Pomerania	II.	II.	II.	II.	II.	II.	II.	II.
	5 Div.	III.	III.	III.	III.	III.	III.	III.	III.
	6 Div. Brandenburg	III.	III.	III.	III.	III.	III.	III.	III.
	7 Div.	IV.	IV.	IV.	IV.	IV.	IV.	IV.	IV.
	8 Div. Prussian Saxony	IV.	IV.	IV.	IV.	IV.	IV.	IV.	IV.
	9 Div.	V.	V.	V.	V.	V.	V.	V.	V.
	10 Div. Posen	V.	V.	V.	V.	V.	V.	V.	V.
	11 Div.	VI.	VI.	VI.	VI.	VI.	VI.	VI.	VI.
	12 Div. Silesia	VI.	VI.	VI.	VI.	VI.	VI.	VI.	VI.
	13 Div. Westphalia	VII.	VII.	VII.	VII.	VII.	VII.	VII.	VII.
	14 Div.	VII.	VII.	VII.	VII.	VII.	VII.	VII.	VII.
15 Div.	VIII.	VIII.	VIII.	VIII.	VIII.	VIII.	VIII.	VIII.	
16 Div. Rhineland	VIII.	VIII.	VIII.	VIII.	VIII.	VIII.	VIII.	VIII.	
Westphalia Acquisitions 1815	17 Div. Schleswig-Holstein	IX.	IX.	IX.	IX.	IX.	IX.	IX.	IX.
	18 Div. Mecklenburg, Hanau towns	IX.	IX.	IX.	IX.	IX.	IX.	IX.	IX.
	19 Div. Hanover	X.	X.	X.	X.	X.	X.	X.	X.
Annexations 1866	20 Div.	X.	X.	X.	X.	X.	X.	X.	X.
	21 Div.	XI.	XI.	XI.	XI.	XI.	XI.	XI.	XI.
	22 Div. Kur-Hessen and Frankfurt	XI.	XI.	XI.	XI.	XI.	XI.	XI.	XI.
	23 Div. Kingdom of Saxony	XII.	XII.	XII.	XII.	XII.	XII.	XII.	XII.
	24 Div. Grand Duchy Hesse-Darmstadt	XII.	XII.	XII.	XII.	XII.	XII.	XII.	XII.
	25 Div.	(XII.)	(XII.)	(XII.)	(XII.)	(XII.)	(XII.)	(XII.)	(XII.)
	26 Div. Württemberg	XIII.	XIII.	XIII.	XIII.	XIII.	XIII.	XIII.	XIII.
	27 Div.	XIII.	XIII.	XIII.	XIII.	XIII.	XIII.	XIII.	XIII.
	28 Div. Baden	XIV.	XIV.	XIV.	XIV.	XIV.	XIV.	XIV.	XIV.
	29 Div.	XIV.	XIV.	XIV.	XIV.	XIV.	XIV.	XIV.	XIV.
German Empire.	30 Div. Alsace-Lorraine	..	..	..	XV.	XV.	XV.	XV.	XV.
	31 Div. (Alsace)	..	..	..	XV.	XV.	XV.	XV.	XV.
	32 Div. Kingdom of Saxony	..	..	..	(XII.)	(XII.)	(XII.)	(XII.)	(XII.)
	33 Div. Alsace-Lorraine	..	..	..	(XV.)	(XV.)	(XV.)	(XV.)	(XV.)
	34 Div. (Lorraine)	..	..	..	..	..	..	..	..
	35 Div. West Prussia	..	..	..	..	XVII.	XVII.	XVII.	XVII.
	36 Div. East Prussia	..	..	..	..	XVII.	XVII.	XVII.	XVII.
	37 Div. N. Kur-Hessen	..	..	..	..	..	(1)	(1)	(1)
	38 Div. S. Alsace	..	..	..	..	..	..	..	..
	39 Div. Kingdom of Saxony	..	..	..	..	..	(XIV)	(XIV)	(XIV)
40 Div. E. Prussia	..	..	..	..	..	XIX.	XIX.	XIX.	
41 Div. Lorraine	..	..	..	..	..	..	..	..	
42 Div.	..	..	..	..	..	..	..	..	
1 Bav.	..	..	1B.	1B.	1B.	1B.	1B.	1B.	
2 Bav.	..	..	1B.	1B.	1B.	1B.	1B.	1B.	
3 Bav.	..	..	1B.	1B.	1B.	1B.	1B.	1B.	
4 Bav. Kingdom of Bavaria (including Bav. Palatinate)	..	..	1B.	1B.	1B.	1B.	1B.	1B.	
5 Bav.	..	..	..	..	..	11B.	11B.	11B.	
6 Bav.	..	..	..	..	..	11B.	11B.	11B.	

N.B.—Two Bavarian army corps (3 divs.), one Württemberg and one Baden division took part in the war of 1870-1 as allies of the N. German Confederation.

Empire period the typical form of growth had been the creation of third divisions in certain corps (usually frontier corps) and which from time to time coalesced in corps possessing districts of their own. These third divisions themselves were the product of a gradual growth. Resources in men, and from time to time the favour of the Reichstag, allowed the formation, now here now there, of regiments and brigades supernumerary to the standard corps establishment (2 divs. = 4 bds. = 8 regts.). In each of the greater reorganizations these supernumeraries had been swept together to form new divisions. But over the last re-

Units in Peace—Each of the 217 infantry regiments had an establishment of three battalions and a machine-gun company of six guns. The field artillery consisted of a brigade of two regiments (in all 12 batteries) per division, one quarter of these batteries being of field howitzers. There were therefore 600 batteries in all. The cavalry, with its recent additions and groupings, numbered 110 regiments, of which 66 were in war to form 11 cavalry divisions, with 33 batteries of horse artillery and 11 cavalry machine-gun detach-

These establishments were, in many cases, hurriedly brought in force at the last moment; the law of 1913 had authorized the necessary recruiting and equipment but had spread it over a term of years.

ments (of 6 guns each). The remainder of the cavalry was to be allotted to the infantry, as divisional cavalry. The foot artillery had been, or was on mobilization, brought to a strength of 25 regiments, out of which came on mobilization a "battalion" of four heavy field batteries per army corps, and also mobile siege trains of considerable strength, the remainder being fortress and coast artillery. For the mobile defence of fortresses there had also been created 16 fortress machine-gun detachments of 6 guns each. The pioneers (engineers) had a strength in 1914 of 32 battalions. Other technical formations are here ignored, owing to considerations of space, but it should be remarked that the most recent laws, those of 1912 and 1913, had provided for considerable expansions in these branches.

One other category of combatant troops remains to be noted, the Jägers (light infantry). In all, 18 Jäger battalions were in existence, some of them specialized to mountain warfare and the remainder (provided with a cyclist company each) to cooperation with the cavalry divisions.

**Strength and Recruiting.**—Although service was universal and obligatory in principle, yet in practice the growth of military establishments had naturally not kept pace with the growth of population, and quite half of the able-bodied males of military age had received no military training whatsoever.

The liabilities of the German citizen to military service are shown in Table B.<sup>1</sup>

With a growing population, and with the competition of the navy for available funds, it was inevitable that there should be this divergence between the theory and the practice of universal service. The *reductio ad absurdum* was reached when, with a population more numerous than that of France in the ratio of seven to four, and in a period of feverish war preparation throughout Europe, Germany was not able to maintain as many soldiers under arms as France. This was the case from 1913 onwards, and it was due primarily to the expenses of the competition in naval armaments. Within the army itself there was no remedy, short of reducing the term of service, and all political and military tradition and influences combined to make this impossible. It was for the court and militarists in Germany an article of faith that the "barrack-army" was the blind instrument of government to be used against external or internal foes. This theory presupposes a discipline like in kind to that of a professional army; the civic characters inseparable from a nation in arms, however highly trained, were obstacles to that discipline, and any move towards converting the army into a citizen force was anathema, even in the year in which the centenary of 1813 was celebrated in a fever of national pride. Yet in Germany, as

TABLE B.—Liability to Service.

17 to 1st muster Lsm. I.	Men selected at 1st muster for infantry	{ 20-22 Active	{ 22-27½ Reserve	27½-32½ Lsh. I.	32½-38½ Lsh. II.		
	do. for cavalry . . . . .	{ 20-23 Active	{ 23-27½ Reserve	27½-30½ Lsh. I.	30½-38½ Lsh. II.		
	Men put back twice and selected at 3rd muster for infantry . . . . .	{ 20-22 Lsm. I.	{ 22-24 Active	24-29½ Reserve	29½-34½ Lsh. I.	34½-38½ Lsh. II.	
	do. for cavalry . . . . .	{ 20-22 Lsm. I.	{ 22-25 Active	25-29½ Reserve	29½-32½ Lsh. I.	32½-38½ Lsh. II.	38½-45 Lsm. II.
	Men allotted to trained Ersatz reserve at 1st muster . . . . .	{ 20-32½ Ers. Res.	{ 32½-38½ Lsh. II.				
	Men allotted to untrained Ersatz reserve at 3rd muster . . . . .	{ 20-22 Lsm. I.	{ 22-32½ Ers. Res.	{ 32½-38½ Lsm. I.			
Men finally assigned to Landsturm I. at 3rd muster . . . . .	{ 20-22 Lsm. I.	{ 22-38½ Lsm. I.					

It will be noted that the Landwehr is exclusively a force of trained men, and Landsturm I. consists wholly of untrained men. The Ersatz reserve, originally intended to produce part-trained drafts for the active army—and always legally on that basis—was in practice a category into which the physically fittest of the men excused from training were put, the remainder going into (or rather staying in) Landsturm I.

Table C gives statistics for recruiting in 1911 and 1912 (the outbreak of war prevented those of 1913 from being published) showing the practical application of the system.

TABLE C.—Recruiting, 1911-2.  
(All figures include navy as well as army.)

Muster:	1911	1912
Men of 20, first appearance . . . . .	503,024	557,608
Men of 21, second appearance . . . . .	367,688	385,163
Men of 22, third appearance . . . . .	289,089	294,825
Older special cases . . . . .	31,574	52,272
	<u>1,271,384</u>	<u>1,289,868</u>
<b>Disposal:</b>		
(a) Struck off . . . . .	826	916
" Excluded " (criminals, etc.), " permanently unfit " . . . . .	35,500	34,811
	<u>36,326</u>	<u>35,727</u>
(b) Put back to following year (aged 20 and 21½) . . . . .	734,563	746,482
(c) Assigned to active service. Voluntarily enlisted (not including volunteers below muster age) . . . . .	39,531	40,413
Levied <sup>2</sup> . . . . .	233,928	239,717
	<u>263,459</u>	<u>280,130</u>
(d) Definitely assigned to inactive categories		
Ersatz reserve <sup>3</sup> . . . . .	94,732	90,207
Landsturm I. <sup>4</sup> . . . . .	142,307	137,922
	<u>237,039</u>	<u>228,129</u>
Total of a, b, c, d . . . . .	<u>1,271,384</u>	<u>1,289,868</u>

elsewhere, a few realized that the prevalent competition in peace strengths was leading nowhere, and that a great European war would be won or lost by nations and not by selected and specialized percentages of nations. Schlieffen, the ablest soldier Germany had produced for 50 years, was one of these. Instead of 50 high-quality divisions, followed after an interval by garrison formations, he proposed to defeat France by the immediate bringing into line of more than 100 divisions in which active and reserve elements were intimately mingled.

As this view, though opposed to the prevailing opinion, proved to be correct, it is unnecessary here to discuss the last stages of competition in peace preparedness before war came in 1914. It is, however, important to note that reservists were called up for refresher trainings in increasing numbers, and that a proportion of the professional officer cadre was set aside for the command of reserve formations in war. Still, these two facts did not indicate with certainty that reserve formations were to appear along with the active, on the first battle-fields. In France, similar measures were taken without any such implication.

When, therefore, the German masses poured through Belgium in Aug. 1914, precious time elapsed before the French G.O.C. became aware that with nearly every identified active corps on the wheeling wing of their opponents was a duplicate reserve corps. The surprise was great, for though it was a matter of

<sup>1</sup> The retention of men in the reserve and other categories for an additional half-year was meant to provide for the event of mobilization between Oct. and March, in which months the youngest class with the colours was still too little trained to mobilize with the rest.

<sup>2</sup> At a man's third appearance his case was bound to be disposed of definitely.

<sup>3</sup> Of whom roughly half, each year, were of the 20-year-old class mustered for the first time.

<sup>4</sup> By far the greater number in these categories had been put back twice.



calculation that men, equipment and officers were available, the professional soldier could not believe that the most rigidly soldierly army of the Continent would put such formations into the front line when there had hardly been time even to establish military routine, let alone to revive the habit of march and manoeuvre in the men.

Yet so it was. Schlieffen's ideas of mass and force, though watered down by his successor Moltke, were translated into practice. Two months later, an even more surprising move was made in the same direction—the employment of troops 75% of whom were entirely untrained at the outset.

In Aug. 1914, the seven armies deployed in the W. included all the 25 active corps except the 1st, 17th and 20th, 70 out of 11 cavalry divisions (Gd., Bav., 2-9), and the following reserve corps:—Guard Res. Corps (3 Guard Divs. made up of supernumerary active units and 1st Gd. Res. Div.); 3rd Res. Corps (5th and 6th Res. Divs.), 4th Res. Corps (7th and 2nd Res. Divs.), 5th Res. Corps (9th and 10th Res. Divs.), 6th Res. Corps (11th and 12th Res. Divs.), 7th Res. Corps (13th and 14th Res. Divs.), 8th Res. Corps (15th and 16th Res. Divs.), 10th Res. Corps (19th Res. Div. of Corps area, and 2nd Gd. Res. Div. so-called), 12th Res. Corps (23rd and 24th Res. Divs., from the two Saxn Corps regions), 14th Res. Corps (26th and 28th Res. Divs. from Württemberg and Baden), 18th Res. Corps (21st and 25th Res. Divs. from the two Hesse, Frankfurt and Darmstadt Corps areas), and 1st Bav. Res. Corps (1st and 18th Res. Divs.). After guarding the N. German coast for some weeks the 9th Res. Corps followed these (17th and 18th Res. Divs.). In the W. also were the 33rd Res. Div. formed at Metz, and the 30th Res. Div. formed at Strassburg, and three momentarily independent Bavarian Res. Bdes.<sup>2</sup>

The VIII. Army in the E. consisted of the 1st, 17th and 20th active Corps, the 1st Cav. Div., the 1st Res. Corps (1st Res. Div. and 36th Res. Div.), the 3rd Res. Div. formed in the II. Corps district.

Thus, in the W., the theatre of the first great decision, 73½ battle divisions were gathered of which 29½ were reserve formations, and in the E. (E. Prussia) six active and three reserve divisions were left to meet the attack of the Russian Vilna and Warsaw armies.

The 17 supernumerary infantry régiments also mentioned were absorbed in these reserve formations (with one exception) and the Instructional Battalion (afterwards famous as the "Lehr Regiment") was expanded to provide the 12th active unit of the Guard. Otherwise these formations were created entirely at the moment of mobilization. Their organization was similar to those of the active army, but for want of guns they were provided only with six batteries per division and had no heavy artillery of their own. In some reserve régiments machine-gun companies did not exist. In sum, and allowing for the active units incorporated, one-third of the first battle forces were reserve (though certainly not improvised) formations.

There were, however, yet other formations not so prepared in advance which found themselves fighting before the end of August. On general mobilization, the reserve, Landwehr, Ersatz reserve and trained men of Landsturm II., up to 42 years of age, had been called out. Landsturm I.—the pool of untrained men of all ages—was left alone, but volunteers presented themselves in enormous numbers. There were thus far more men than the depots could accommodate, and the volunteers were for the moment only registered. Enough men remained in the trained categories and in the Ersatz reserve not only to fill the active and reserve, but create (a) Landwehr and (b) so-called Ersatz formations, as well as units of Landsturm for guarding railways and other sensitive points and for the sedentary garrisons of forts.

**Landwehr.**—Landwehr brigades were formed to carry out the secondary duties which, it had been supposed, would fall to reserve divisions. The Ersatz, and to some extent the reserve formations, having absorbed part of the resources of Landwehr I., these brigades

were constituted with the remainder and principally with Landwehr II., that is, trained men up to the age of 38. Each army corps district, according to the resources of the region and also according to its output of "Ersatz" formation,<sup>3</sup> produced two or three Landwehr brigades, nearly all with a proportion of artillery and cavalry and engineers attached. In all, 99 régiments and some other units, making 314 battalions in all, mobilized in early Aug. 1914. Of these, 30 brigades were assigned to the W. to follow the various armies or to constitute the garrisons of fortresses (Metz, Strassburg, upper Rhine defences). Nearly all the remainder (about 17 brigades and several régiments as well), in the E., formed fortress garrisons and frontier guards which were very quickly drawn into the battles—indeed one whole corps, the Landwehr Corps (3rd and 4th Landwehr Divs.), was constituted as a field formation at the outset, and others also were formed into divisions. In connexion with these brigades and their coming into line, it should be added that just as they had relieved field troops of the necessity of occupying territory and guarding communications, so in turn they were after a short time relieved by Landsturm battalions, formed all over the empire from what remained of Landwehr II. and from the trained men of Landsturm II., up to 42 years of age.

**Ersatz.**—The term "ersatz" (replacement or substitute) was confined in normal usage to the category of reservists who were simply registered, not (as a rule) trained, and kept at call to fill gaps in the active army. It was, further, the official designation of the depot battalions which were formed on mobilization to provide drafts for active reserve or Landwehr units on service. But the resources of Ersatz battalions at the moment of mobilization were such that, in addition to allocating drafts for the field units, it was possible to create new units on a large scale. The principle followed in the case of the infantry—which was applied to other arms with suitable modifications—was for the Ersatz battalion of each regimental district to form and equip two service companies. Thus each brigade district was able to produce a battalion (known as a brigade Ersatz battalion), and the sum of these "B.E.Bs." with analogous units of the other arms, appeared in the field in the last days of Aug. 1914 as "Ersatz Divisions" (Guard, 4th, 8th, 10th, 19th and Bavarian). These divisions had an irregular organization; they consisted of two to four mixed brigades, each brigade having four or five battalions, four batteries, a half squadron of cavalry and an engineer unit.<sup>4</sup> In addition, the Ersatz battalions of a few reserve and Landwehr régiments also constituted B.E.Bs., and those of the reserve were grouped in two mixed brigades (Res. Ersatz Bdes.).

The six divisions cited above all took part in the western campaign after the first few days of battle. They were provided wholly by the Ersatz battalions of the western and central corps regions. In the E. a different system was followed.

It has been mentioned that three active corps, one and a half reserve corps and about 17 Landwehr brigades had been assigned to the eastern theatre. But in the alarm created by the Russian advance on E. Prussia, an instant augmentation became necessary. The formation of "B.E.Bs." was not attempted in the I., XII and XVII. regions and only partially and temporarily tried in the V. and VI. Instead, the Ersatz battalions themselves were mobilized, every man who could be equipped being sent into the field, and only the surplus remaining behind to form the nucleus of new draft-finding battalions. The German general staff, in this as in all other cases, took great risks in improvising formations in the east. Not only Landwehr and Ersatz battalions, but the most diverse units of all categories were put together in provisional régiments, brigades and divisions, first as mobile fortress garrisons but soon as field troops.<sup>5</sup> It was no doubt considered that racial passion would give such forces a military value as against the Russians that would compensate for their deficiencies of training equipment. These miscellaneous eastern formations constituted the Thorn, Breslau, Graudenz, Posen and Königsberg "Reserves" or "Corps," of which the two last named were equivalent to two divisions each, the others to one each. The formation of the Silesian Landwehr Corps of two divisions has already been mentioned. Further, one so-called "reserve" division, the (original) 35th, was created from the readiest elements of the Thorn mobile garrison, and yet another division was thrown off before the Thorn reserve as such became fixed as a division. The five fortresses named in fact were to say no more than in which in various pulsations régiments, brigades, and divisions were successively discharged.

By the end of Aug., therefore, the German forces in the field consisted of several categories—the active divisions of peacetime, the reserve divisions nearly equivalent to the active in

<sup>2</sup> No Guard Landwehr infantry régiments were formed.

<sup>3</sup> Most Landwehr brigades were also constituted as mixed brigades—in their case two régiments with troops of other arms attached.

<sup>4</sup> As an example, Runge's regiment of Griepenkner's detachment, Thorn Corps, which in the winter of 1914-5 seems to have consisted of half a mobile Ersatz battalion from the XVII. Corps region, half a mobile Ersatz battalion from the II. region, the mobile Ersatz battalions of the 101st and 107th Saxons and parts of three Landsturm battalions from Posen province and Alsace.

<sup>1</sup> Staff was guard, but not troops.

<sup>5</sup> Other formations called "Reserve" detailed later were so only in name.



solidity of organization, the Ersatz and Landwehr divisions, improvised but composed wholly of trained men and organized according to scheme; and wholly improvised, divisions hurriedly put together from miscellaneous sources in the fortresses of the east. Further, there were a number of mixed Landwehr brigades, both in the W. and the E., in addition to those forming parts of divisions, and a large number of Landsturm units, serving wholly as garrison troops in the W. but not uncommonly incorporated in mobile Ersatz formations in the east.

The operating forces as apart from the fortress garrisons and the troops allotted to occupied territory and lines of communication were divided into eight armies, I.-VII. in France and Belgium (in numerical order from right to left), and VIII. in E. Prussia. The Silesian Landwehr Corps (under Woyrsch) formed a separate command operating with the Austro-Hungarian armies.

The command was exercised by the Kaiser nominally, by the chief of the general staff (Moltke, Falkenhayn, Hindenburg) actually. In addition to supervising the eastern front and controlling war policy, the great general staff in its war form (the "supreme army direction," *Oberste Heeresleitung* or O.H.L.) directly commanded operations in France. From first to last no special commander-in-chief was appointed for the western front.

In the E. the VIII. Army grew into a great organization, comprising at one time in 1915 seven German armies, without counting Austrian armies included in its scope, or the German Southern Army which was outside it. This organization was under the commander-in-chief E. (*Oberbefehlshaber ost* or *Oberost*), under whose headquarters the armies were grouped in two or more groups of armies (*Heeresgruppen*). But in spite of his title, the commander-in-chief E. exercised no powers of command over the Austrian front. Not until much later indeed was there unity of command in any form. As in the case of the Entente armies in the W., combined operations had always to be arranged between the German commander-in-chief E., through the chief of the general staff, with the Austrian higher command. Crises due to differences of opinion between the three authorities concerned were naturally frequent, and only gradually, by providing more and more assistance by direct reinforcements,<sup>3</sup> did the German command obtain an ascendancy that was effective, and then it was the chief of the staff of the army and not the commander-in-chief E. who obtained and exercised it.

In the W., there was a strong case for the formation of groups of armies from the outset. The expedient of placing one army under the orders of another was tried occasionally, with unsatisfactory results. Otherwise, the control of events in the Marne campaign was in the hands of a distant O.H.L. into whose business the eastern front constantly thrust itself and which at one time (late Sept. 1914) seems to have had two heads. It was not until trench warfare had set in that groups of armies were formed in France. In sum, then, partly through events and partly from unwillingness to appoint a commander-in-chief in the only theatre in which German forces were employed exclusively, the offices of chief-of-staff and of commander-in-chief E. came to be overloaded with a mass of very varied functions which ranged from advising on economic policy and negotiating with Turkish staff officers and Lithuanian clergymen to weighing the pros and cons of a two-division operation. This was a considerable factor in the final defeat.

The strength in units of the three arms for both fronts and for the interior in Aug. 1914 may be taken, inclusive of Landsturm, as 1,700 battalions, 980 field and horse batteries, and 450-500 heavy (including immobile fortress) batteries.

Of these, approximately 987 battalions, 490 squadrons, and 820 field batteries of active, reserve and Ersatz formations, with,

<sup>1</sup> *Heer* in German implies always the army as a whole, the "Host." The *Heeresgruppe* is a major subdivision of the *Heer*, and consists of several *Armeen* (armies) or *Armeegruppen* (army-groups, i.e. groups of corps either as small or too temporary in character to be regularly constituted as "armies" with defined areas and lines of communication).

<sup>2</sup> Finally, by allocating individual German battalions to Austrian divisions.

behind them, some 165 battalions and 28 squadrons and 30 field batteries of Landwehr, formed the western forces. To these should be added about 120 mobile batteries of heavy artillery (6-in. howitzers, 4-in. gun and upward). In order to arrive at a criterion of combatant strength it has become customary to use the infantry division as the unit, and to count unattached forces as equivalent to 50 many divisions, chiefly according to their infantry strength. It is calculated that there were in existence in the first weeks of the war 123 German divisions, or their equivalents in Landwehr and fortress brigades. Of these 77 constituted divisions and the Landwehr, etc., equivalent of 20 more were in the western theatre on Aug. 23 (the date of "high water" in the first phase), and 26 divisions or equivalents in the field and the fortresses (chiefly the latter) in the E., of which 13 at most could be considered as constituted divisions. In Sept. a naval division (shortly afterwards expanded to a corps) was formed and added to the forces in Belgium, for military duty and (later) for coast defence also.

Including engineers, communication troops, administrative troops and others of all categories, the total ration strength of the army immediately after mobilization may be taken at about 5,000,000. The number of untrained men liable to service (including youths of 17-20) was about the same.

*The New Formations of Sept. 1914.*—The organization of all the above forces was either existing or deliberately prepared for in peace, with the exception of the Ersatz formations, and even as regards these latter, the idea of creating and employing them dates back to Schlieffen's tenure of office. But, especially, all had the common characteristic that they consisted wholly of men trained with the colours in peace.

The next pulsation of the national effort, in the last days of Aug. 1914, was the creation of a series of reserve divisions in which 75% of the rank and file were totally untrained. It has been noted that the *Kriegsfreiwilligen*, who presented themselves to the number of about a million, had merely been registered. As soon as the mobilization tide had receded and the depots were free, viz. about the middle of Aug., these men were called up, and formed, with a percentage of trained men (chiefly Landwehr II.), into new "Reserve" units—numbered in the case of the infantry regiments from 201 upwards. These units were assembled in training camps, officered by such retired and reserve officers as were still available, constituted into brigades, divisions and army corps, and within six to eight weeks of formation thrown into the furnace of battle at Ypres and Lodz.

There were 13 of these divisions (43-54 R.D. and 6th Bav. R.D.), 12 constituting the 6 corps 22 R.-27 R. They have been described by German writers as "the glory of the country and the shame of the general staff"—the glory of the country in that the flower of its young men composed them, and the shame of the general staff in that, with a universal-service system existing in law and in practice, it had been unable to devise a system of service that would absorb and train them. These were the "levies" who advanced in masses, singing, under the rifle fire of the British Expeditionary Force at Ypres and of the Fusiliers Marins at Dixmude, and who at Lodz, with the Guard Res. Corps, first broke into the Russian positions and then extricated themselves from the most extraordinary "pocket" recorded in the history of the war. The story of these divisions may be interpreted in several ways. It will suffice here to say that their effort was the culminating point of the attempt to win the war outright, and that with its failure to do so, the German nation, not less than the army authorities, began to realize that the war would be a contest of endurance.

One more series of new divisions was created, however, before the policy of preparing for a war of endurance was applied to recruiting. The class of recruits who would normally have joined for training in Oct. 1914 were called up when the depots were clear of the first "new reserve" regiments. These (infantry regiments 240-273 R.) with the remainder of the *Kriegsfreiwilligen*, were, unlike the preceding divisions, held back for intensive training before being put in the field. They constituted the 75th-82nd Res. Divs. (38-41 R. Corps) and 8th Bav. Res. Divs.

and were not put into the field till the "winter battle of Masuria" in Feb. 1915.

These divisions (except the Bavarian) were constituted on a new organic basis—that of three infantry regiments under one brigade staff instead of four in two brigades, a form which, as will appear presently, came to be adopted throughout the whole army. In artillery strength they were however superior to all previous reserve formations. The original reserve divisions had only six 6-gun batteries, and the first new reserve divisions, hurriedly mobilized as they were, had nine 4-gun batteries. In these second new reserves, the number of batteries was increased to 12 (as in active formations, but with 4 guns in lieu of 6 per battery).

With the creation of these divisions expansion proper ceased. Until 1917 no further divisions were formed otherwise than by regrouping existing units, and the intake of recruits of successive classes was, with very few exceptions, used for maintenance only. The end of Jan. 1915, therefore, marks the close of the expansion period. At that date there were 147 infantry divisions, or equivalents of infantry divisions.

Regrouping had naturally as its object the better strategic and tactical utilization of these 147 divisions. The first step was to sort out the miscellaneous formations of Ersatz and Landwehr, especially in the east. Accordingly, the Posen, Thorn, etc., corps were recast, divorced from the fortresses from which they had already become separated, and constituted as the 83rd–89th Divisions. These were on the 4-regiment basis, and the regiments after reorganization took the numbers 329–354 and 372–381 save that Landwehr units comprised in these divisions retained their original designations.

The battalions of Ersatz on the W. front (the "B.E.Bs.") were regimented chiefly with numbers between 357 and 371. On both western and eastern fronts the Landwehr brigades still unattached were used to form divisions, bringing the number of this category up to 19 (1–5, 6th Bav., 7–18, 1st Bavarian.)

The next step was a more important one. It had become clear, first of all, that the army corps, as a working unit, was not supple enough, and as early as Sept. 1914 the practice had set in, both with the Germans and with the French, of regarding the corps headquarters as an organ for the tactical and administrative management of any two or more divisions which might be assigned to it. This led in sedentary warfare to the corps becoming an area or sector command, and in open warfare or for the handling of battle reserves as a headquarters told off to carry out a particular mission. In either case, the inferiority of the German numbers in both theatres of war enforced a better arrangement of the corps commander's forces than the 2 × 2 system gave. In the spring of 1915, therefore, two series of divisions, numbered 50–58 (even numbers), 101–107<sup>1</sup> and 111–123 (odd numbers), 4th Guard and 10th and 11th Bav., were formed by taking a regiment each, and also one-quarter of the divisional artillery, from 50 or more existing active or reserve divisions. Thenceforward, practically half the divisions of the army were on the new basis.

One other formation of the spring of 1915 must be mentioned. This was the Alpenkorps, a division formed for high mountain work when it became evident that Italy would enter the war. This *corps d'élite* served in every theatre, not only in mountainous country, and at the last moment of the war was dispatched from France to attempt to stop the Allied advance in Serbia. It was exclusively Bavarian in composition.

During the spring and summer of 1915, to ensure against accidents, the effectives of units in 3-regiment divisions were considerably increased, company strengths of over 300 being frequent. Later, however, the precaution being seen to be unnecessary, some new divisions were formed out of this surplus; these were the 183, 185, 187 and 192, originally called flying (*i.e.* non-sector) "brigades," but from the outset practically equivalent to divisions of the new type.

Practically no further additions were made till the battle of the Somme and the intervention of Rumania created a new

The 108 and 109 were improvised during the eastern offensive of 1915. 25th–32nd Res Divs (38–41 R Corps) and 8th Bav.

situation. The creation of the so-called 5th Ersatz Div. and the 25th and 47th Landwehr Divs. (all three mixed brigades reconverted to the status of new type divisions) hardly amounted to more than a change of name.

The total of divisions and "equivalents" (the latter always diminishing as formations were regularized) remained stationary at the figure of 172 from July 1915 to the end of May 1916. The ration strength of the army was on March 31 1915, 5,029,672, and on March 31 1916, 6,767,144, and the losses had been as follows:—(8 months up to) March 31 1915, 281,389 killed; 205,048 missing, 835,612 wounded, 13,402 died of disease, etc. (12 months up to) March 31 1916, 376,954 killed, 121,040 missing, 897,475 wounded, 29,840 died of disease, etc. The "definitive" losses—dead, missing, wounded discharged as unfit—are difficult to establish; but if we take for wounded not returned to duty the figure of 29% (which is a high one), we arrive at a total of "definitive" losses of all kinds of about 1,780,000 for the whole period. To repair these losses, and to increase the ration strength by some 1,750,000 men as well, the intake of recruits necessary would be about 2,500,000. These recruits were (a) the *Kriegsfreiwillingen*, (b) the class 1914, called up somewhat after the normal date, (c) the class 1915 called up before the normal date, and (d) the class 1916 called up before the normal year.

As early as the autumn of 1915, in fact, Germany had been compelled to anticipate the conscription, to bring youths of 19 as well as those of 20 to muster, and to shorten the period of training to the minimum.

The general policy followed was to consider a class collectively as a means to be allotted to specific ends. Later in the war the practice was carried to the extent that even when called up, trained and ready, a class was under embargo and could not be sent into the front line until the chief-of-staff, in consultation with the Government, should issue an order removing the ban. What may be called routine losses and wastage were made good as a rule by returned sick and wounded or other experienced men rather than by recruits.

Early in 1915, partly in order to have a reserve at hand, and partly in order to ensure an intensive training under realistic conditions, the system of "Field Recruit Depots" was gradually introduced. When these had been established, men spent only half or less than half of the abbreviated training period allowed in the Ersatz battalion at home and the remainder in the Field Recruit Depot a few miles behind the front. Eventually there was one depot per division, with an establishment (in 1917) of 1,350, of whom 900 were recruits under training and the rest training staff and returned wounded waiting allocation. Further, as pools to meet losses which could not be covered by the depots of the divisions affected, large training centres were created at Beverloo (the peace training camp of the Belgian army) and at Warsaw. The training camps in Germany were of course utilized for home training, and in them from time to time new batches of divisions were created and assembled. The period spent by the soldier in training varied considerably: sometimes it was as little as one month in the Ersatz battalion and two or three weeks in the Field Recruit Depot or at Beverloo; in less critical times it might be four to five months in all.

Hitherto, it will be noticed, little or no call had been made on the 5,000,000 men composing the untrained half of the male population of military age. This was because the maintenance of the country's economic life was more necessary than ever as the blockade tightened its pressure. Nevertheless, a certain combing-out of agriculture and industries began in the winter of 1915–16. Further, a law was passed in 1916 for the re-examination of men who had been rejected by the annual muster commissions as permanently unfit.

From the summer of 1916 the situation of the German army became very critical. The costly offensive of Verdun had been followed by the Allied offensive on the Somme, the Russian break-through at Lutsk, the sixth Isonzo battle, and immediately thereafter Rumania's declaration of war. For the first time since 1914 the Central Powers were face to face with a simultaneous and prolonged strain on all fronts.

Before describing the measures taken to deal with this crisis, it is convenient to review the changes which had taken place in the meantime in the constitution of the fighting units themselves.

The new type divisional organization has already been set forth, but within the infantry regiment itself there had been important changes, and there had grown up, besides, a great force of non-divisional troops, which were in some cases a pool from which allocations were temporarily made to armies as required, and in others were sector troops permanently allotted to particular parts of the front irrespective of the divisions occupying them. By now, the process of moving divisions into line and out to rest had become thoroughly established, though Verdun was the first battle in which the relief process was reduced to an almost mechanical system.

The changes may best be dealt with by arms.

**Artillery.**—It has been noted above that in the great reorganization of the spring of 1915 the field artillery had been recast on the basis of the 4-gun battery. The number of batteries therefore shows a large increase in that year, corresponding to the creation of new divisions. But in the main, the number of field guns and howitzers remained at the same level as in the spring of 1915. It was in the heavy and medium artillery (these were not differentiated in Germany) that expansion, as distinct from regrouping, occurred. The fortress guns were made mobile by various methods and old field guns of 9 cm. were brought out and replaced as position guns on the less important parts of the front, pending the production of modern weapons; and in these and other ways the number of batteries of "foot artillery" actually in the field was increased from about 150 in Aug. 1914 to about 1,100 by the autumn of 1915 and 1,200 by the summer of 1916. The batteries received various descriptions, which need not be given here; substantially, they were grouped as required under "battalion" staffs, and when actually in line were under control of the divisional artillery command of the sector. Thus was initiated a principle of organization which presently became general in the belligerent armies and was applied to field artillery also—that of dividing the artillery into a portion which belonged organically to divisions and moved in and out of line with them, and a portion which was under higher control; this portion was partly employed in the various sectors as a normal allocation, partly kept in reserve to bring up the normal artillery strength of this or that sector to battle standard, as required.

**Machine-guns.**—Probably no legend of the war period obtained a wider circulation or was availed with more authority than the assertion that Germany put into the field in 1914 an enormously superior force of machine-guns. The facts, however, were known throughout to the Allied intelligence staffs, and are, as regards 1914-5, in no way extraordinary.

At the outset, Germany had only just completed the equipment of the active infantry with two guns per 1,000 rifles—the same scale as that of the British and French and Russian armies. The only difference was that they were employed in batteries, regimentally, instead of by sections battalion-wise as on the side of the Entente, and this no doubt produced a battle-field impression of inferiority on the British and French side since where German guns were used at all, they were used in mass. There were further some 16 (on mobilization 32) fortress machine-gun detachments, and 11 horse machine-gun detachments allotted to the 11 cavalry divisions.

On mobilization, the majority of the reserve regiments were also provided with machine-gun companies, but for the armament of the remainder and of Ersatz and Landwehr units the fortress machine-gun detachments were called into the field at once. The first and second new reserves were sent into the field with one section of two guns per regiment. From all sources, the total of machine-guns in service at the end of 1914 was not more than 2,000, as against a peace establishment of 1,600.

But the Germans were the first to recognize the predominant rôle of the machine-gun in trench warfare. Manufacture was started on a scale then considered adequate, and during 1915 there were large additions. The regimental companies, where missing, were created, and further a number of "field sections" or "supplementary sections" were formed and attached to regiments as required. Thus by the end of 1915 every regiment had, either in organic companies or in attached sections, a force of 9 to 12 guns, though it was not until after the middle of 1916 that the latter figure was reached universally.

Meantime, a new type of machine-gun organization had come into existence, the "M.G. Sharpshooter Troops," each troop having six guns. These were selected from the "sections" of 1915, specially trained, grouped in permanent "detachments" (*Absteilungen*) and attached to divisions as required for battle. Their début was at Verdun in March 1916. By that date the number of guns in service had increased to about 8,000, and by the end of 1916 this figure was doubled.

At the period here considered, the light machine-gun, afterwards the primary armament of all German infantry, had hardly come into existence. Experiments had been made in the battle of Champagne (Sept.-Oct. 1915) and elsewhere with units armed with the Maudeen gun and styled "Muskeltabattalion," but the results were not promising. The success of the French *justi mitrailleurs* and the

British Lewis gun, however, made action imperative, and towards the end of 1915, to save the time which would have been lost in trying out and manufacturing a new model, the service heavy machine-gun was lightened sufficiently for use as an infantry weapon. This was not issued on a large scale till the end of 1916.

**Trench Mortars (Minenwerfer).**—At the outset of the war, the trench mortar (adopted as the result of the siege of Port Arthur) was a close combat weapon of siege warfare handled by sappers; in this rôle it figured at the sieges of Liège and Antwerp, where its bombs were highly effective. It was, however, the needs of trench warfare which brought it prominently to the front. As in other armies, the infantry felt the want of some short-range weapon which would enable them by curved fire to destroy and to harass the opposite trenches, and the creation of trench-mortar units soon followed. The Germans had here a real advantage in that they already possessed experience of the design and manufacture of these weapons, and for a considerable period they had the upper hand in this respect. The standard organization was by sections of heavy, medium, and light Minenwerfer which belonged to the pioneer arm, which were permanently assigned to divisions and were allotted within the division as required. Other Minenwerfer units were grouped in battalions and constituted a G.H.Q. reserve. Later the light Minenwerfer sections were permanently assigned to regiments, the others continuing as divisional troops.

Infantry organization as such remained unaltered, though the establishment was reduced in 1916, in order to meet the demands for men which were created by machine-gun and Minenwerfer expansion. At the same time a process began which in the long run proved injurious to quality but for the moment justified itself, the formation of Assault "Storm" battalions. These were created, in anticipation of the Verdun offensive, in the winter of 1915-6, and were so successful that presently all infantry regiments and some battalions and companies raised their own assault detachments or squads. In the assault battalions proper, all trench warfare means were combined within the unit infantry guns, trench mortars, machine-guns and light flamethrowers. The separation of this élite from the bulk of the infantry was recognized by privileges and distinctions of dress. The net result, however, was to deprive the infantry of a leaven of first-class men, who in 1918 could no longer be spared from the ranks of their units. Towards the close of the war, therefore, the assault battalions were broken up one by one, and all assault units came to be regarded as schools of offensive tactics rather than as battle units.

**Cavalry.**—Little change had occurred in the cavalry between 1914 and 1916. Divisional cavalry was gradually reduced. All the cavalry divisions which had figured in the campaign of the Marne were sent E. by 1915; and there they played a conspicuous part in the operations both mounted and in the trenches. At the period now being considered (middle of 1916) they were still true mounted forces, though employed in the line like others. Cavalry regiments were each provided with a machine-gun squadron in 1915.

**Pioneers.**—Besides the Minenwerfer and chemical-warfare troops which had come into existence, other special services had been added to the pioneers, notably a large number of searchlight sections, Survey and sound-ranging units formed part of the artillery and not, as in the British service, of the engineers. The proportion of the pioneers themselves (British "field companies R.E.") was also augmented, and much use was made in 1915 of semi-permanent "Infantry Pioneer Companies" which were in reality infantry working parties detailed for particular pieces of constructional work, and retained as units till these were completed. From 1916, a large number of new Landsturm battalions were formed, as labour battalions.

The possibility of Rumanian intervention had been foreseen for some time, and in preparation for it four new divisions had been created by regroupings in the eastern theatre. These were the 195th, 197th, 199th and 200th, all these were principally composed of Jäger battalions assembled in regiments, and the last named, like the Alpenkorps, was specialized for mountain work. A little later the 91st, 92nd, 93rd Divs. were formed in Poland for quiet parts of the front. Several mixed Landwehr brigades were also expanded into Landwehr divisions for the same service. At the same time the 197 class was called up gradually (May-Aug. 1916) for training, 15 months before the normal time, and the product of the March comb-out of industry was brought under training at the same time.

These measures, however, were not sufficient. To meet the pressure on all fronts not only men were needed, but, still more, increased flexibility of manoeuvre, and it became essential, therefore, to create new battle-worthy divisions. These were obtained partly by regrouping, and partly—in the early months of 1917—by creating another batch of wholly new divisions.

During the crisis itself, which extended from July 1 to Dec., and then, with a brief respite, from Feb. to May 1917, it was

impossible to carry out regrouping with the smooth regularity of March 1915; the measures taken, therefore, extend over the whole period. They were as follows: (a) The constitution of new divisions (201-204 and 12th Bav.) out of odd units existing in various theatres and of "combing" obtained in the lines of communication, the Ersatz battalions and other military establishments in Germany. The infantry regiments of these divisions were numbered 401-416 and 26-28 Bavarian. (b) The regrouping of all old divisions still remaining on the 4-regiment basis as 3-regiment formations of the new standard type—i.e. the completion of the process which had been half carried out in March 1915. This yielded the divisions 205-226, the 5th Guard Div., the 3rd Marine Div., and the Bavarian divisions 14th, 16th, and 19th Reserve—in all 27, apart from some additional Landwehr divisions obtained in the same way. Certain divisions, which lost not one but two regiments in this regrouping process, were compensated by new regiments numbered 389-400, 417-441 and 477, these being formed by grouping experienced companies taken from existing regiments of every kind. Somewhat later, on the verge of the offensive of Caporetto, the Jäger battalions still available and unallotted were grouped in a "Jäger Division," the last high-quality formation created in the war. (c) The creation of a series of new divisions, in somewhat the same way as the old first and second new reserves, at training camps in Germany. The quality of these was, however, far below that of the new armies of 1914. Although 50% were returned wounded men and men drafted back from the fronts, the remainder were of the class 1918, called up nearly two years in advance. (d) The numbers of these divisions were 231-242 and 15th Bav. (regiments 442-476, and 30-32 Bav.). At the time of the creation of these, the old 8th Ersatz Div. took the number 243. The creation of a series of divisions for home defences and garrison duty, which in effect were only groupings of existing Landsturm (in some cases Landwehr) resources. Of these only the 251st, 252nd, and 253rd were actually formed as such. The Metz mobile reserve which had existed since Aug. 1914, was numbered into this series; later it was freed from all connexion with the fortress, and a new Metz mobile reserve was formed in the last months of the war.

These measures, in their ensemble, increased the number of divisions or "equivalents" (the last being by now very few) from 172 to 213 in Jan. 1917, and 223 in May 1917, the final total reached being 238 in Oct. 1917. The 1917 class, the combed men of March 1916, and the soldiers who could be claimed from back areas, by no means sufficed to cover the needs of these new formations, at the same time as they made good the losses of Verdun; the Somme, Rumania and Russia, not to mention Arras and the Aisne. Already in Aug. 1916 there began the examination muster of the 1918 class, and by mid-November it began to join for training, though not one of its members had reached the age of 19. By now, too, the effective value of a "class" had sunk considerably, because of the percentage which had to be rejected not only for immaturity but for malnutrition as well.

The ration strength of the army, taken on the same basis as the previous figures, had grown by March 31 1917 to 7,630,456, but the loss of 311,034 killed, 26,016 dead of disease, 192,380 missing and about 250,000 disabled (of 875,107 wounded), in all about 775,000, had compelled the recruiting authorities to find some 1,643,000 recruits in the 12 months. And it was precisely at this period (Oct. 1916) that, under the energetic pressure of Hindenburg and Ludendorff—who had succeeded Falkenhayn at the moment of the Rumanian crisis—a great munition production campaign was started in Germany, which necessitated the recall to the factories of a large number (125,000 men in the armies '16-17) of mobilized workmen and a check to the process of coming-out. On the eve of the battle of the Somme, the strength of the German army in *combatants only* was 2,260,000 in the W. and 500,000 in the E., or (neglecting the small forces in the Balkans and Turkey) 2,850,000 on all fronts.

In spite of the fact that the line had held both in the W. and in the E., and that Rumania, with its material resources, had

been conquered into the bargain, the outlook for 1917 was dark. The Russian Revolution came, with its enigmas; unrestricted submarine warfare was proclaimed with the foreseen result of bringing America into the war on the side of the Entente; and the British and French offensive was planned in a hope, almost amounting to certainty, that the defence would break down. Skilful defence, and sins of omission and commission on the side of the Entente, weathered this crisis for Germany, with a lower figure of losses than in any previous year, and Hindenburg and Ludendorff were able to collect such free reserves as allowed them to check the last Russian offensive, inflict two defeats which ended the war in the E., and to carry through the Caporetto offensive that so nearly ruined Italy.

This they were enabled to achieve—so far as the factors were under their own control—by using up the class of 1918, by creating as many manœuvre units as possible, by employing every means that presented itself to stiffen the sinking moral of the war-weary army, and by new tactical methods, of which the most characteristic element was the light machine-gun. These guns were already in the spring of 1917 available on the scale of three per company. By the close of the year most companies had six, and during 1918 the issue of both light and heavy machine-guns for defence against low-flying aeroplanes was extended to batteries and to transport columns of every sort. Heavy machine-guns, too, had risen in number to one company of 10-12 guns per infantry battalion, besides those of the divisional "M.G. Sharpshooter detachment" which numbered 36.

The characteristic of the army of 1917-8 therefore became economy of man-power, through constant augmentation of machine-gun power. Whereas in 1914 a 12-battalion active division possessed 24 machine-guns, in the winter of 1917-8 a 9-battalion division possessed 216 light and 142 heavy, or 358 in all. The rifle strength of the standard battle unit had been halved, and the machine-gun strength multiplied 15 times in about three and a half years, even without taking anti-aircraft machine-guns into account. The ratio of fire-power to men exposed had very nearly tripled.

At this point, when the stage was being set for the final act, it is desirable to summarize in tabular form the number and distribution of German divisions (and "equivalents") during the first three years in which manœuvre on interior lines was constant. Table D forms, rightly understood, a summary of the history of the World War, so far as Europe is concerned. Directly or indirectly, it reflects all its vicissitudes.

Amongst these divisions a certain classification in respect of quality had been set up. In 1914 Landwehr and Ersatz and new reserve formations had been differentiated from active and reserve and from each other in composition and rôle, but with the constant and, till 1917, somewhat haphazard replacements of casualties, differences based on provenance had disappeared. Instead, differences based on battle experience had come into force, and though largely accidental at the outset, they had become effective through the machinery of replacements. Divisions recognized as "shock-troops" (a legacy of the trench-warfare period) were dignified by the name of *Grosskampfdivisionen* in their offensive aspect and *Eingreifdivisionen* ("intervention" or counter-attack divisions) on their defensive; and they received the pick of the recruits and returned wounded. The rest, formations fit to hold the line merely, were currently called "sector" divisions, and received, in the main, less battle-worthy elements in their drafts. A real, though admittedly undesirable, distinction was thus established. The Entente intelligence staff rated the 203 divisions of the western front with which it was concerned in 1918 thus: 61 "very good," 103 "average," 22 "poor."

The difference was not reflected in organization, except in the sense that "shock" divisions were the first to be equipped to any new scale that had been decided upon. Thus, such divisions were the first to receive their complement of six light machine-guns per company. In 1918 they received a fuller allowance of transport, and also, as part of their "organic" artillery, a group of medium guns (two batteries 15-cm. howitzers and one battery 10-cm. long guns) in addition to their field artillery.

TABLE D.—Distribution of Divisions.

	Western Theatre.	Eastern Theatre.	Other Theatres	Total divisions or equivalents.
<b>1914</b>				
Aug. begin	97	36	..	123
Aug. end	93	30	..	123
Sept.	93	30	..	123
Oct.	106	32	..	138
Nov.	104	34	..	138
Dec.	98	40	..	138
<b>1915</b>				
Jan. end	201	46	..	147
Feb.	99	48	..	147
March	101	53	..	154
April	103	56	..	161
May	106	64	1 (Ital.)	171
June	106	64	1 "	171
July	105	68	1 "	171
Aug.	104	67	1 "	172
Sept.	107	56	8 (Balk.)	172
Oct.	114	47	11 "	172
Nov.	117	46	9 "	172
Dec.	118	47	7 "	172
<b>1916</b>				
Jan.	118	47	7 "	172
Feb.	121	47	4 "	172
March	123	46	3 "	172
April	124	45	3 "	172
May	125	45	2 "	172
June	122	49	2 "	173
July	123	52	2 "	177
Aug.	119	62	2 "	183
Sept.	128	68	2 "	198
Oct.	128	75	2 "	205
Nov.	130	73	2 "	205
Dec.	135	72	2 "	209
<b>1917</b>				
Jan.	139	71	3 "	213
Feb.	144	68	3 "	215
March	151	72	3 "	226
April	156	72	3 "	231
May	155	78	3 "	233
June	155	78	3 "	236
July	148	85	3 "	236
Aug.	147	86	3 "	236
Sept.	149	82	3 (Balk.)	237
			3 (Ital.)	
Oct.	147	81	3 (Balk.)	238
			7 (Ital.)	
Nov.	153	74	8 (Ital.)	238
Dec.	168	61	3 (Balk.)	238
			6 (Ital.)	
<b>1918</b>				
Jan.	174	57	3 (Balk.)	238
			4 (Ital.)	
Feb.	185	49	3 (Balk.)	238
			1 (Ital.)	
March	197	39	2 (Balk.)	238
April	202	34	1 "	237
May	208	32	..	240

The divisions in line were under corps staffs which though long fixed in sector still retained the old numbers they had had in the open warfare of 1914-5, with a district or personal designation (e.g. Gruppe Lille, Gruppe Conta) as well. Certain corps staffs numbered above 50, which had neither troops nor home regions of their own, had been created in 1915-6 as reserve headquarters available for the control of particular operations. The corps or "group" were allotted to armies which from right to left (sea to Switzerland) were as follows:—IV. (Flanders), VI. (Artois), XVII. (Artois), II. (Picardy), XVIII. (N. of Oise), VII. (S. of Oise), I. (Reims), III. (Champagne), V. (Verdun); and thence to the Swiss border a series of army groups (small armies) known as C., XIX. Army, A., B.

These armies were grouped in groups of armies (*Heeresgruppen*) known by the names of their commanders—Prince Rupprecht (IV., VI., XVII., II.), German Crown Prince (XVIII., VII., I., III.), Gallwitz (V., C.), Duke Albrecht (XIX., A., B.). During Aug. 1918 a Heeresgruppe Boehn was created, between Rupprecht and the German Crown Prince, comprising the XVIII., the IX. (staff brought over from Russia) and the VII., but did not last long. The XVIII. Army was then assigned to Rupprecht and the IX. staff was withdrawn, and the VII. returned to the German Crown Prince's group of armies.

Some 40 divisions remained on the eastern front to overawe the Soviet Government to "prevent the formation of an Anglo-Bolshevik front," and to occupy the corn lands of S. Russia. These were gradually "milked" of their best elements, and had a reduced artillery strength.

At this date (end of March 1918) the ration strength of the whole German army had increased to 7,917,170. The losses of the period April 1 1917 to March 31 1918—which must include some at any rate of the casualties of the "Michael" offensive—had been 257,748 killed, 37,004 died of disease, 138,070 missing, 679,777 wounded; and the "definitive" losses may be taken at 650,000. Comparison of these figures with those for 1916-7 gives a measure of the relief which was afforded to Germany by the success of her defence and the breakdown of the Entente's 1917 offensive. Only about 900,000 recruits had to be found instead of 1,600,000 as in 1916-7. Recruiting policy was accordingly less desperate. The 1919 class was called to the colours without haste—though still two years in advance of the proper time—trained carefully, and acclimatized to war conditions on the quiet Russian front, in the winter of 1917-8. It was regarded by Ludendorff collectively as the means of replacing the casualties to be expected in his great offensive. A great effort was made by drastic combing-out of industries not only to obtain combatants but also substitutes for every battle-fit man who was still serving in rear areas and on quiet fronts. Even the Alsations and Lorrainers, hitherto employed almost exclusively on the eastern front, were to be brought over and incorporated in Rhineland units, in whose provincial patriotism it was thought that the Alsations and Lorrainers might be brought to share. This was only an extension of a practice which had already been begun in 1916 of re-sorting the personnel of units according to their province of origin, as in the pre-war army.

The moral of the army was still good. In spite of war-weariness, it was felt that in one last effort peace could be won. For the first time the Germans enjoyed a numerical superiority and leisure for thorough battle training. If at home discontent was ready to break out in revolt, the effects were not at that period felt at the front, owing to an industrious propaganda, assiduous "welfare work," and largely to the disappearance of peace-time social barriers between men and officers—the latter, indeed, being now for the most part either commissioned or made acting officers from the ranks.

The offensive of March 1918 was launched, and was successful, but at heavy cost, and it did not win the war. Others followed it, always with the same result. By the end of April the 1919 class was largely absorbed, and preparations were being made for the call-up of the 1920 class. By the end of July 1919 men were practically exhausted, and the now incessant battle casualties had to be made good by returned wounded. Meantime

Otherwise, the equipment and organization of all the divisions assembled in France in March 1918 was the same—three infantry regiments, each regiment with its three battalions, three machine-gun companies, and three light Minenwerfer detachments, the whole under an infantry brigade staff; one field artillery regiment of two groups guns and one group howitzers (in all nine batteries), which (with sector artillery or reinforcing artillery) was under the divisional artillery staff; (one M.G. Sharpshooter detachment of 36 M.G.); three heavy and medium Minenwerfer batteries which, a little later, were reformed, with the light M.W. units, as infantry regimental companies. In the case of attack divisions, a group of three batteries of medium artillery was included organically and up to 40 or 45 army batteries attached for the purposes of a particular battle. In one respect only was material preparation wanting. Tanks were not looked upon with favour, only a few units being constituted.

All cavalry divisions in the W. were dismounted and acting as infantry in quiet parts of the line. They were in process of reconstitution as infantry under the name of Schützen.

numerical superiority disappeared with the accelerated arrival of American divisions in France. By July 1 the rifle strength of the Germans was 100,000 below that of the Allies. Two Austrian divisions, and converted cavalry divisions, which were brought into action during the summer, were hardly more than a drop in the bucket. Company strengths could no longer be maintained. More and more the army became an army of machine-gunners, practising the infiltration method in attack and the elastic method in defence, but in its growing disillusionment becoming less and less apt for either form, since both demanded a high moral in the isolated squad which formed the fighting unit.

As early as May it was decided to break up certain formations and to use their personnel as drafts for others. This process was carried out on a large scale from the end of July; 13 divisions disappeared by the end of Aug., 10 more in Sept. and 3 more in the first days of Oct. The 1920 class, called up and trained, reached the field depots from Aug. onwards, but for political reasons sanction was refused for its employment in the front line. This was the last resource, for unless a winter's respite could be obtained, the most complete combing-out of home industries and agriculture—now in any case impossible owing to the political situation—would not have yielded a sufficient supply of trained combatants.

The sinking of moral in the army manifested itself in the "black day" of Aug. 8. During that month and Sept., in spite of the stout resistance of many formations, the sentiment of defeat spread. At the last a final effort of propaganda convinced the army that by fighting hard, and only so, it might obtain honourable terms of peace. But it was too late. The end had come in Germany.

With the evacuation of occupied territory and the march home to demobilization—in most cases self-demobilization—the history of the Prussian and German army system built up by Frederick the Great, Scharnhorst and Moltke, came to an end.

The losses in the concluding year, from April 1 1918 to March 31 1919, are stated at 303,923 killed, 48,751 died of disease, 334,802 missing, and 823,408 wounded, representing a "definitive" loss of about 946,000.

In the whole war, the losses amounted to 1,531,048 killed, 155,013 died of disease, 991,340 missing, 4,211,469 wounded; or a total of 6,888,870 for recorded military casualties.

(C. F. A.)

### IX.—THE AUSTRO-HUNGARIAN ARMY

Till a few years before the World War it could be said that no great state took as little care for its army as the Dual Monarchy. National differences and constant party conflict prevented anything more than the barest necessities of maintenance being provided for, and stagnation and even retrogression ruled in the army itself in consequence. This was especially true during the period 1903-6, in which the constitutional conflicts in Hungary focussed themselves principally upon the question of the Common Army and led to difficulties of which the consequences were serious indeed. There were, however, in the last few years two causes at work which led to important developments. The first of these was the eternal Balkan question, which on two occasions—the Annexation Crisis of the spring of 1909 and the Balkan War of 1912-3—brought Austria-Hungary to the verge of war. Each time Austria-Hungary was unready for war. But the long-deferred modernization of the military system was, under the pressure of circumstances, taken in hand, at any rate so far as patching up the more obvious defects was concerned.

The greatest sins of omission in the past had been those affecting the artillery; the danger of war in the south-east led to these being repaired, at any rate so far as the limited means allocated allowed of it, and also to machine-guns being provided. The latter had been under experiment with cavalry and mounted troops since 1903, and it was not until 1908 that their employment became general.

The second important influence was that of the two-years' service scheme introduced in July 1912. This was only brought into effect after a prolonged parliamentary conflict, for the Hun-

garian opposition had used the opportunity to try to obtain, by tactics of obstruction, the separation of the Common Army into two parts, and, at the least, the acceptance of Hungarian as a language of command. In these struggles the ministerial party finally had its way, but the reforms it sought to bring about were shorn in the process of most of their efficacy. Indeed, so low was the agreed peace effective of the units that the army, compared with those of the other military powers, might fairly be regarded as having a militia character. The two-years' service principle was, however, made law and applied to all parts of the armed forces of the Dual Monarchy.

These parts were five in number: (a) the Common or Imperial and Royal (K.u.K.) Army, (b) the Imperial Royal (K.K.) Austrian Landwehr; (c) the Royal Hungarian Landwehr (Honved); (d) the Austrian (K.K.), and (e) the Royal Hungarian Landsturms. The basic principle of this partition was that the Common Army would form the first line in an external war; the two Landwehrs the second, and the two Landsturms the third. An especial function of the last named was the garrisoning of fortresses and duty on lines of communication and in the interior. But in the last 20 years before 1914 the two Landwehrs had been brought on to the same organic and tactical level as that of the Common Army, excepting only that their peace effective within the unit was considerably lower. They were therefore in 1914 fit to be put into the first line at the outset, like the Common Army—as indeed it was essential that they should be, in view of the enormous numerical superiority that had to be faced. As it turned out, even the Landsturm, which had no peace-time existence at all, was sent into action at once, newly formed and ill equipped, on many parts of the front. The enthusiasm of the younger and the quiet resolution of the older Landsturm men, however, showed their worthiness in spite of all defects. But the experiment was a costly one in lives.

At the outbreak of war in 1914 the constitution of these forces was as follows: under the Supreme Command of the Emperor, and the direction of the War Ministry for the Common Army (and the Navy), the Austrian Ministry of Defence for the K.K. Landwehr and Landsturm, and the Hungarian "Honved Ministry" for the Honved and Hungarian Landsturm. There were six general inspectorates, and 16 corps commands each with its own territorial region.

*Common Army.*—Infantry: 32 Inf. Troops Divs. (I.T.D.), each of 12-16 battalions and 7-8 batteries with 74 inf. or mountain bdes. Cavalry: 8 Cav. Troops Divs. (K.T.D.), each of 24 squadrons and 3 batteries; 19 cav. bdes. Artillery: 14 field and 3 mountain bdes., 42 field-gun regts. (each 5-6 batteries and a depot cadre), 14 field-howitzer regts. (each 4 batteries and a depot cadre), 14 heavy-howitzer divs. (each 2 batteries), 10 horse-artillery divs. (each 3 batteries), 10 mountain-artillery regts. (each 4 batteries of guns or howitzers, and depot cadre). Fortress artillery: 5 bdes.; 6 regts. (each of 2-3 battalions, and depot cadre); 8 independent battalions. Technical troops: 14 sapper battalions, 8 pioneer battalions; one railway and one telegraph regt.; bridging battalion; flying depot cadre. Train: 16 battalions and mechanical transport cadres.

*K.K. Landwehr.*—Infantry: 8 Landwehr divs.; 16 bdes.; 40 Schützen (Landesschützen) regts. (as in Common Army but of 3 battalions each). Cavalry: one cav. div.; 2 bdes.; 6 regts. mounted Schützen (organized as Common Army cav. regts.) detachments each of 3 squadrons in Tirol and Dalmatia. Artillery: 8 divs. field howitzers (each of 2 batteries).

*Honved.*—Infantry: 7 district divs., and one non-territorial div.; 16 bdes.; 28 regts. (each of 3 battalions). Cavalry: 2 cav. divs.; 4 cav. bdes.; 10 cav. regts. (organized as in Common Army). Artillery: 2 field-gun regts. (each of 8 batteries and depot cadre).

The infantry was armed with the 1895 8-mm. magazine rifle, except in the case of third-line units which were largely armed with rifles of the 86, 86/88, and 90/91 patterns. The field gun was an 8-cm. Q.F., the field howitzer a 10-cm., of old model (as were also the heavy howitzers), but of good power. All these guns were of steel-bronze and therefore inferior, especially in range, to those of other powers. The siege artillery included 12-cm. guns, 24-cm. mortars, and 30-5-cm. tractor-drawn mortars—the last-named remarkable weapons which found employment in field as well as in siege warfare. There were, further, the fortress armaments. The cavalry was uniformly equipped (sword and carbine), and well horsed. Theoretical training was



carried to a very high degree, but its application to practice was not perfect. The directing organs—General Staff, Intendance—were adequate and well trained.

In general it may be said that no army suffered from such unfavourable conditions for the formation and development of a sound and uniform military spirit as the Austro-Hungarian. All the more remarkable, then, is its actual performance in the World War, a performance which, in view of the handicaps, must be regarded as unique in history and can only be explained by the existence of a sentiment of military virtue, rooted in age-long traditions, which carried the army through to the very end.

**Mobilization.**—In spite of the fairly evident attitude of Russia, it was hoped in Austria-Hungary that the crisis of 1914 would be confined to a war against Serbia and Montenegro. Three armies were formed in the south-east. But when on July 30 the first combats were taking place on the Drina and the strategic deployment was in full swing, Russia came on the scene. The mobilization, hitherto partial only, became general, and the bulk of the forces of the Dual Monarchy formed up in Galicia, nine corps proceeding thither direct while three corps already engaged against the Serbs, or about to do so, were drawn off to the north. Mobilization and concentration, as such, were carried out without a hitch, and the transfer of the II. Army to the N. also produced no delays worth mentioning.

**Infantry during the War.**—The infantry worthily sustained its part as the "keystone of battle," and this is true not only of those serving with the colours at the outbreak of war but of reservists, Lehr men, Landsturm men of all kinds who far surpassed expectations. Apart from considerable changes, the infantry organization of 1914 was much the same as in 1910. The peace effective had, however, been augmented by the increase in the recruit contingent. New drill regulations had appeared in 1911, and new field-service regulations in 1912.

In Aug. 1914 the Common Army included 102 infantry regts.; 4 Bosno-Herzegovinian regts., 4 Tirolese Kaiserjäger regts. (all at 4 *kompanie* battalions), also 29 Feldjäger battalions, one Bosn.-Herz. Feldjäger battalion, and 6 frontier companies in Bosnia and Herzegovina. The first reinforcement to replace casualties was provided for by 28 "march" regts., which followed the army into the field. The Austrian Landwehr had 37 inf. and 3 Tirolese Landesschützen regts., and the Honved, 32 inf. regts.—all these being on a 3-battalion footing. The Austrian Landwehr possessed no "march" regiments, the Honved on the contrary had 16. On the outbreak of war, from the 1st and 2nd bans of the Landsturm there were formed 38 Austrian and 32 Hungarian Landsturm regiments, as well as many independent Landsturm units, the number of which was temporarily augmented later when the Landsturm age limits were extended to 18-55 years.

Battalion strength was about 1,000 rifles, except in march battalions, which varied from 800 to 1,000, and in Landsturm battalions which rarely exceeded 800.

Reinforcements were provided for in the war by sending up monthly one march battalion per regiment. Thus, in the course of the war, 48 march battalions were sent into the field for each infantry regiment. Five regiments (including the 3 Tirolese) of the Austrian Landwehr were organized as mountain troops. Independent Jäger battalions were organized like infantry battalions, and had "march companies" as their reinforcement organ. Machine-gun detachments had been in process of formation for some years, and by 1913 all infantry battalions (and cavalry divisions) had them. The detachment was of 2 guns in the case of the infantry, 4 in those of the cavalry. In 1915 Landsturm machine-gun detachments were gradually formed for certain Landsturm battalions. In 1916 the number of guns in a detachment was doubled, in 1917 trebled. The last year also saw the introduction of the hand machine-gun (light machine-gun), each *battalione* forming a *Zug* of four *Schwärme* (squads), each *Schwarm* having 2 guns.

The introduction of new methods and weapons in the war, of course, led in due course to the grenade, the shrapnel helmet and the gas mask being added to the infantryman's equipment. At the outset of the war regiments and independent battalions had pioneer sections, but the available stores were inadequate and had at once to be increased. After 1916 the pioneer sections were expanded into "technical companies" (one per regiment or independent battalion), and consisting each of an infantry searchlight, a trench mortar and a bombardier section. The usefulness of these units, which possessed also some bridging material, was three or four times as great as that of the original pioneer section. The telephone equipment, introduced in 1911 but treated as a stepchild, was augmented considerably in the war, and towards the end each regiment had a section and each battalion a squad (*Schwarm*) of telephones, the first named having 26 posts and 52 km. of cable, the second 6 posts and 12 km. of cable.

A further technical development was the introduction of the 37-mm. infantry gun.

Numerically, the organization of the infantry remained unchanged till the middle of 1915. In the second half of that year three Feldjäger, two Bosn.-Herz. Jäger battalions, a combined infantry regiment and the 103rd Regt. were formed, and also a number of fortress battalions for service in the Bosno-Herzegovinian forts. The last named, however, were dissolved in 1916.

In Jan. 1916 the 104th Regt., and the 4th-8th Bosn.-Herz. Jäger battalions were created. In June the frontier companies were expanded into battalions and in Sept. the 5th Bosn.-Herz. regt. was formed. In Jan. 1917 the 29th and 37th reserve infantry regts., the 105th-109th infantry regts., and some combined "half-regiments" were created from various sources.

The creation of all these units was more or less in the nature of a temporary expedient imposed by the necessity of manning an ever-growing front. It was evidently desirable to systematize the process of expansion, and therefore in Oct. 1917 a complete reorganization of the infantry was taken in hand, concurrently with a reorganization of the infantry division itself. All regiments were now uniformly organized on a three-battalion footing, and from the fourth battalions available and the four newest Bosn.-Herz. Jäger battalions, new three-battalion regiments were created. At the beginning of 1918, therefore, there were 138 infantry, 4 Tirolese Kaiserjäger, and 8 Bosn.-Herz. regts., each of three battalions. In May 1918 a 139th regt. was added. The number of Feldjäger battalions, the (four) Bosn.-Herz. Jäger battalions and the frontier Jäger battalions remained the same.

In the Austrian Landwehr there was no change in numbers, but in the spring of 1917 the regiments were renamed Schützen regiments, the Tirolese Landesschützen became Kaiserschützen, and the two Austrian regiments, 4th and 27th, formed as mountain troops, were renamed 1st and 2nd mountain regiments. The Hungarian Landwehr officially styled Honved after the spring of 1917) formed in the course of the war 17 new regiments, numbered 500-516. At the end of the war the Landsturm formations in existence were 15 regiments, 41 independent battalions, 4 Tirolese battalions, and in Hungary 8 regiments and 16 independent battalions. Lastly there were 91 Austrian and 65 Hungarian Landsturm line-of-communication battalions.

**Storm Battalions.**—Patrols (squads) of picked men trained to grenade work and employed for special enterprises were already in existence in the spring of 1916, especially on the Isonzo front. These were followed in the latter part of 1917 by storm troops proper, and at the beginning of 1918 each infantry division headquarters possessed a storm battalion and each cavalry division headquarters and each independent infantry brigade a corresponding unit, all these being formed from the storm troops of regiments, brigades, etc.

**High mountain and guide companies** were formed to train guides for troops engaged in the more difficult Alpine work. These numbered 20 and 13 respectively at the end of the war. **Cyclist units** existed even before the war (Jan. 1912), four companies from certain Jäger battalions being assembled as a unit. This unit did very well, and in the war cyclist battalions were created in the Hungarian Honved, in both Landstürms (and in the Navy). Early in 1918 the three battalions were named 1st and 2nd, and Honved cyclists.

**Cavalry.**—The Austro-Hungarian cavalry was, according to the ideas and standards prevailing before the war, superbly trained. Officers, men and horses were first-class. But the ideas and standards were out-of-date. The principle of using cavalry as a battle-arm still prevailed, whereas the Russian cavalry, having absorbed the lessons of the most recent wars, rarely showed themselves in big masses, but worked in mixed groups consisting of cavalry, machine-gun detachments, artillery and cyclists.

In 1910 Austria-Hungary had possessed eight cavalry divisions of the Common Army, to which in 1912 were added two Honved cavalry divisions, and on the outbreak of war a 9th Cav. Div. formed in the Austrian Landwehr. The regiments were: 15 Dragoon, 16 Hussar, 11 Ulan, 6 K.K. Lwhr. Ulan (these renamed mounted Schützen in 1917), 10 Hungarian Honved Hussar regts., and smaller units in Tirol and Dalmatia. At the outbreak of war Hungary formed 10 Hussar half-regts. of Landsturm. In each regiment further 1st and 2nd reserve squadrons were formed. The bulk of this mounted force was grouped in 11 divisions (at 4 regiments per division) and the rest, including the reserve squadrons, allotted in pairs or threes as divisional cavalry to the infantry divisions or corps. The rôle of the cavalry divisions was exploration and screening, that of the divisional squadrons liaison and local scouting with the infantry. In both cases the performance of these functions met with unexpectedly great difficulties owing to the thoroughly modern tactics employed by the Russian cavalry, which employed all the methods of dismounted fire fighting and rarely came to open mounted attack. This imposed at once a restriction in the cavalry methods of the Austrians. Little stress had been laid on fire fighting in peace, but when position warfare set in in 1915, and still more when horses became scarce in 1917, mounted work fell more and more into the background. The equipment was revolutionized. The soldier was provided with wire cutters, grenades, obstacle material, etc. Already in the spring of 1915 the unserviceable uniforms of peace-time had given way to grey. The useless sabre was replaced by the bayonet.

Thus, and in other ways, the army rapidly adjusted itself to the new conditions. Even in the winter 1914-5 certain formations had



created dismantled sections, and these in time became the basis of Schützen *divisionen* of cavalry, analogous to infantry battalions.

In the winter 1917-8 a thorough reorganization was carried out. The regiment which at the outset had comprised 6 squadrons of 150 sabres each, one pioneer section, and one telegraph patrol, was reconstituted on the basis of 2 half-regiments each of 4 squadrons dismantled; 2 machine-gun squadrons (8 guns each), 2 hand machine-gun sections and a technical squadron, besides an infantry gun section comprising 2 trench mortar squads, 2 bombthrower squads, one searchlight squad, and one cavalry telephone squad. The equipment of the individual man was assimilated to that of the infantry soldier. In each infantry and cavalry division there only remained mounted one squadron of divisional cavalry.

The cav. div., which had originally comprised 2 brigades, 4 regiments, 1-2 machine-gun detachments, and a horse artillery division (three 4-gun batteries), consisted on the new basis of one (or 2) brigade headquarters, 4 dismantled regiments, one storm regiment, one sapper section, one telegraph company (if required, one radio company) and one mounted squadron. From the available horse artillery were formed "mounted field artillery" regts., each of 2 gun, 4 howitzer, and 1 trench mortar batteries. In 1918 it was planned to create brigades of horse artillery for the cavalry divisions, each consisting of one of the horse regts. and a heavy artillery regiment.

In March 1918 a 12th (mounted Schützen) Div. was created out of 4 regiments of that category.

**Artillery.**—No arm in any army was so completely transformed in the war as the Austro-Hungarian artillery. Though worthy of its ancient reputation in point of science and training, it suffered at the outset from inferior material. Whereas Russia and Serbia taking to heart the lessons of Manchuria had modernized their guns, in Austria-Hungary these necessities were buried on political and financial grounds.

It is true that the gun introduced in 1905 was a modern Q.F. equipment, equivalent to Russian and Serbian weapons of the same class. But the field and heavy howitzers, dating from 1880 and 1899 were, like the mountain guns and howitzers, obsolete and ineffective. Inadequate too was the fortress artillery. Apart from some 30-5-cm. mortar batteries, sent at the outbreak of war to the western front, and some 24-cm. mortar batteries, only quite obsolete guns were available.

In the years preceding the war, indeed, the most urgently necessary steps had been taken towards modernizing of the artillery. In the first place numerical increase was necessary. As against the 72-54 guns per division of other powers Austria-Hungary had only 42.

After various augmentations in the last two years the artillery consisted at the outbreak of war of 42 army, 8 Landwehr and 8 Honved field-gun regiments, each of 5 batteries (4 in the Landwehr and Honved divisions); 28 army and 8 Landwehr field howitzer divisions (each of 2 batteries); 9 army and one Honved horse artillery divisions (each 3 batteries); 14 heavy artillery divisions (each 2 batteries); 10 mountain artillery regiments (each of 4 gun and 2 howitzer batteries), and one independent mountain division; 6 regiments and 7 battalions of fortress artillery.

During the war the development of the artillery was naturally ceaseless. It began with the replacement of old-pattern guns and increases in the available numbers of field guns. At the beginning of 1915 the old field and heavy howitzers were replaced by Q.F. 10-cm. and 15-cm. weapons, and a modern 10-4-cm. long gun ranging to 12 km. was brought out. Further, two completely modern mountain equipments (7-5-cm. gun and 10-cm. howitzer models 1915, ranging to 7 and 8 km.) gradually supplanted the older types.

In the course of the war the former ratio of howitzers to guns was greatly modified, till finally the former preponderated. In succession, batteries were taken from the field-gun regiments and re-formed in new howitzer regiments. The heavy howitzer divisions were augmented and in part armed with the new 15-cm. equipment, and further, 11 10-4-cm. heavy-gun batteries, as well as some heavy howitzer divisions in both Landwehrs, were created.

By the end of 1915 the proportion of howitzers had come to be about 50%, and at the end of the war there were three times as many howitzers as there were guns.

Up to the end of 1915 the mountain artillery had been augmented by 5 regiments, the fortress artillery by one battalion, while the number of 30-5-cm. batteries increased to 20. At that date the formation was in progress of motorized batteries of 15-cm. guns and howitzers (ranging to 18 and 12 km. respectively). At the beginning of 1916 all K.K. and Hungarian Landwehr howitzer divisions were grouped, by four in the case of the light, by three in that of the heavy, into regiments. At the same time greater attention was paid to the anti-aircraft artillery, which received modern as well as improvised weapons.

At the end of 1916 there were: 28 army, 8 Landwehr, 8 Honved, 14 army reserve, 3 Honved reserve field-gun regiments, 9 horse artillery divisions; 28 army, 8 Landwehr, 8 Honved, 14 army reserve, 4 Landwehr reserve, 3 Honved reserve field howitzer regiments; 45 anti-aircraft batteries; 30 army, 8 Landwehr, 8 Honved, 3 army

reserve, one Honved reserve heavy field artillery regiments; 20 army, 4 Landwehr, 3 Honved mountain artillery regiments.

At this period the introduction of 21-cm. mortars, of 38- and 42-cm. mortars and of 24- and 35-cm. long guns into the armament of the fortress artillery was in progress. These were completely modern guns, were motorized, and ranged to 15 km. in the case of the mortars and to 26-32 km. in that of the guns. Twelve trench mortar batteries were also added to the fortress artillery.

This organization remained substantially unaltered during 1917, the only noteworthy change being the transformation of the horse artillery already alluded to (summer 1917), the steady augmentation in the number of fortress batteries and the increased employment of heavy naval guns.

In connection with the reorganization of the infantry divisions at the end of 1917 the artillery was of course recast also. In peace-time the artillery regiments, etc., had been so arranged that in each corps area an artillery brigadier commanded all units of the arm in that area. In war each infantry division had originally a brigade of artillery (one regiment field guns, one division howitzers<sup>2</sup>). In Feb. 1918 the organization took up its final form. The artillery regiments were uniformly reorganized with gun and howitzer batteries in each; and the designation "Field Artillery" was adopted by all. Each artillery brigade (one per division, i.e. 66) henceforth consisted of 2 field artillery regiments, one heavy field artillery regiment and one mountain artillery group. The field regiments had 2 gun and 3 howitzer batteries, and either a trench mortar or an anti-aircraft battery. The heavy field artillery regiment had 4-5 batteries, one only being armed with 10-4-cm. guns and the others with 15-cm. howitzers. The mountain artillery group had 2 gun and one howitzer battery.

The artillery, with cavalry divisions, was similarly reorganized and gradually provided with heavy artillery units.

After providing for the above-mentioned mountain groups, there remained 14 independent regiments of that branch. These were constituted as a G.H.Q. reserve, and each consisted of 6 gun and 3 howitzer batteries.

At the end of the war the field and mountain artillery of the Austro-Hungarian army amounted to a total of 864 light, 328 heavy, and 324 mountain batteries, as against 369 light, 28 heavy and 74 mountain at the outset.

The fortress artillery was also reorganized, and renamed "heavy artillery." Hitherto its organization had varied according to its allocation to fortresses, but thenceforward it was formed in 14 regiments each of 4 groups at 4 batteries. On the verge of the Armistice 4 independent groups were created at Trieste, in Dalmatia, and in Montenegro.

**Technical Troops.**—In 1893 the previously existing engineer and pioneer corps were reconstituted as a single pioneer corps carrying out all engineer duties; this corps consisted of 15 battalions. In 1912 a new subdivision was introduced. "Pioneers" were allocated to water work and "Sappers" to land and fortress work—as had been the case before 1893. The pioneer corps then consisted of 8 four-company battalions and the sapper corps of 14 three-company battalions. At the same time a special bridging battalion (for semi-permanent work) and a river-mining company were created. Both corps did their work well in the war, but they were far too small.

At the beginning of the war a 9th Pioneer Battalion was in existence, and the number of companies in each battalion had risen to 5 in the pioneer, 6 in the sapper battalions. The army was accompanied in the field by a variety of technical formations such as tool columns and mobile parks. The bridging equipment consisted of 126 units, each capable of 53 miles of bridging.

The inadequacy of numbers was made good immediately after the outbreak of war by creating Landsturm sapper companies and numerous works detachments.

In the middle of 1915 a second bridging battalion was raised, and by the end of that year trench mortar, bombthrower and electro-technical units were in existence. The pioneer battalions had now up to six companies and the sapper battalions up to ten. In 1917 a special battalion was formed for offensive gas warfare. Other technical branches were created to deal with close-combat means (air-mining, powder-mining, bombthrower sections, compressed air, oxygen and air-liquifying stations); electro-technical matters (searchlights, live-wire obstacles, accumulators, drinking water and pumping machinery, ventilators, boring tools) and other things, and these were constantly augmented.

The thoroughly going reorganization of winter 1917-8 affected also the technical troops. The pioneers were abolished, and all technical services placed in the hands of the sappers, while close-combat means and searchlights were transferred to infantry, cavalry and artillery formations. Thenceforward the sapper corps consisted of 60 three-company battalions (1 per division and the remainder to corps, etc.), 1 flamethrower battalion, and numerous bridging tool and other units. To the sappers now belonged also the well-boring and the electro

<sup>1</sup> Each of the 10 regiments formed an additional battery of guns on mobilization.

<sup>2</sup> In the 8 K.K. Landwehr divisions an army gun regiment of 4 batteries, a Landwehr gun division of 2, and a Landwehr howitzer division of 2. In the 8 Honved divisions, 1-2 divisions of an army gun regiment and one Honved gun regiment.

formations. Searchlight units now consisted of one company (2 holed 35-cm., 2 motorized 60-cm., 2 motorized 110-cm. projectors) per division, as well as a number of similar units under G.H.Q., and odd formations; further, each technical company or squadron of an infantry or dismounted cavalry regiment included a searchlight squad.

**Communications Troops.**—Till May 1912 only one combined railway and telegraph regiment existed. This was divided at that date into two. The railway regiment consisted of 3 battalions, depot cadres for personnel, track, and for locomotives, and fortress light railway cadres at Przemysl, Cracow and Pola. The companies constituting these battalions were charged in war with the construction, operation and destruction both of standard gauge and of light railways. Consisting at the outset of 30 railway and 4 railway operating companies, this branch had risen at the end of the war to a strength of 39 railway and 32 field railway companies. In occupied territory under Austro-Hungarian control 4 army railway commands were set up (Poland, Serbia, Italy, Rumania) which had at their disposal 8 operating battalions and 28 operating companies. For transport in mountain regions (Alps, Rumania, Albania) there were 49 telpher operating and 9 telpher building companies. The light railway service consisted at the end of the war of 3 locomotive and 21 motor and one horse operating sections, as well as 3 operating sections at Pola. Associated with the railway troops were some bridging detachments provided with iron-bridge equipment.

Lastly should be mentioned **armoured trains**. The first of these, an armoured locomotive, was improvised in 1914 to reconnoitre the enemy during the Galician retreat. Later five trains were built.

The telegraph regiment consisted of 4 battalions, one radio detachment, depot cadre and an administrative unit for stores. This regiment was the parent of all telegraph and telephone units which came into the field, but as with other arms and branches, expansions had to be regularized in the winter of 1917-8. The reorganization in that period reconstituted all telegraph and telephone units uniformly as "telegraph companies," of which at the close of the war there were 159, as well as 65 line construction companies and 25 radio companies. Corps, army and higher headquarters had in all 72 radio posts, worked as 14 administrative groups, and there were 7 fixed stations for long-distance work.

**Flying Corps.**—Numerically Austria-Hungary was far behind other states in the numbers of her flying troops. Till a few years before the war only captive and free balloons were in use, chiefly in fortresses, and modern aerostatics in Austria were practically followed only as a sport. However, a reorganization took place in 1913 which enabled the army to begin the war with one flying company of 6 machines at G.H.Q. and at each army headquarters, one dirigible balloon company, and depot units. As in other countries, necessity led to rapid developments from this nucleus. By the end of 1916 there were 37 flying companies allotted to the higher headquarters. In 1917 a specialization of flying units according to their missions was begun; thenceforward there were divisional companies for line and artillery work; deep reconnaissance companies, pursuit companies for air fighting, "big machine" companies (bombers), protective companies for escort of divisional machines, and photographic companies for map work. In Nov. 1918 the total of units was 82 flying companies, 32 balloon companies, 12 parks, 9 motor repair units, and 2 construction companies.

**Metéorological Service.**—This was attached to the flying service, but provided for the requirements of all others as well, and was represented in all formations from divisions upwards.

**Motor Transport Troops.**—Before the war the use of motor transport for military purposes was limited. For liaison duties between headquarters an Automobile Volunteer Corps and a Motorcycle Volunteer Corps had been formed in Austria and an Automobile Volunteer Corps in Hungary some time before the war. But the first motor troops proper were created in the war itself, when the motorization of the train (ammunition, supplies, medical) and the necessity of regularizing the supply of cars, lorries, parts and fuel imposed this step.

At the outset only a very small proportion of the train was motorized, the lorries coming from private firms by way of requisition.

On formation the "Auto troops" were classified broadly as field troops and home service troops. The first named included by the end of the war 31 group commands and 238 auto columns, 39 ambulance columns, 10 postal columns. The auto troops at home were responsible for the transport of stores and supplies of all kinds to the army and for the training of reinforcements.

**Trains.**—The training of the transport corps (Train) in peace-time was thorough. The vehicles designed for mountain and normal ground proved, however, too heavy for the soft morasses of Galicia and Poland, and for the move forward echelons of transport local vehicles had to be requisitioned. On the other hand the special equipment provided for mountain warfare was excellent.

After the abolition of the regimental organization in 1910 the train consisted of 16 train divs. (one per corps), which in peace carried out all transport duties within the corps and its area, and on mobilization had to provide horses and drivers for all transport formations and for the transport of bridging, postal, medical and other formations. The "division" itself remained at home as a draft and remount producing centre.

The expansion of the army naturally entailed corresponding developments in the Train Corps, which underwent a considerable reorganization in the winter of 1916-7. Simplification of supply procedure and the replacement of heavy military wagons by light vehicles of local types were the main features of this reorganization.

**Mountain Warfare Organization.**—In Austria-Hungary the organization of mountain troops had been carried further than any other state. At the outbreak of war there existed, as has been mentioned earlier, five mountain regiments of Austrian Landwehr (16 battalions) which were intended as a frontier guard in face of the Italian Alps. But in 1914 they were used against Russia, Serbia and Montenegro like any other regiment without regard to their special character, and although they in due course returned to the Italian theatre, they were not, as a special arm, augmented during the war, though reinforced by a number of locally raised units. In fact, the generally mountainous nature of the frontiers and war theatres of Austria-Hungary required rather that all troops, and not merely a specialized fraction, should be adaptable to hill warfare.

Thus the troops normally quartered in Dalmatia, Bosnia and Herzegovina, though not essentially mountain units, possessed a special organization in peace-time. The operations unit was the "mountain brigade" which consisted of battalions detached from their regiments, of Bosno-Herzegovinian units, and of mountain artillery. There were 14 such brigades on the south-eastern front at the opening of hostilities, constituting the four divisions of the XV. and XVI. Army Corps. The brigade consisted of 4-6 battalions, sometimes one frontier company, a troop of cavalry and 1-2 batteries, and its engineer and administration services were organized for mountain work. The division had 2 additional mountain batteries, and its headquarter services were partly on the mountain and partly on the normal base.

As, however, all but one of the theatres of war in which the army was called on to operate were mountainous, this organization was evidently insufficient. Even as early as the winter of 1914-5 there were many improvisations—for example in the Carpathians battle, in which both Austrian and German divisions sent to reinforce von Pflanzer-Baltin had to be reconstituted with mountain transport—and towards the end of the war practically three-quarters of the whole army stood in hill country. Naturally, therefore, a procedure was arrived at whereby any formation on going to a mountainous theatre automatically took on the required form. In the reorganization of 1917-8, indeed, the mountain brigades proper, which meantime had increased in number to 33, became normal infantry brigades, there being no longer any need for them to retain their special character.

**Totals of Units in 1914 and 1918.**—A general comparison of the organization by units at the beginning of the end of the war summarizes clearly the changes which had taken place. In Aug. 1914 the front line strength of the army in units was about 1,000 battalions, 400 squadrons, and 2,800 mobile guns. In the summer of 1918 the detail is as follows: 262 infantry regiments, also 241 Ersatz battalions, and 170 battalions and 80 companies of volunteers, coast defence troops, etc.; 12 mounted and 48 dismounted cavalry regiments; 132 field artillery regiments, 12 horse artillery regiments, 14 mountain artillery regiments, 66 mountain artillery groups, 14 mortar regiments, 1 gas projector unit, etc.; 60 sapper, river-mining and bridging battalions, etc.; 140 bridging trains; 112 bridging sections; 82 flying companies, 32 balloon companies, 4 electro-battalions, 240 telegraph companies, 8 battalions and 800 companies of railway troops, 10 searchlight companies and 400 searchlight squads, etc. The sum, as regards front-line strength, totals 1,200 battalions (including adapted cavalry); 72 squadrons, 7,000 mobile guns. (1911)

**Higher Formations.**—At the beginning of the war there were 16 corps headquarters, and 32 divisions of the Common Army, 8 of the K.K. Landwehr and 8 of the Honved, with 9 army and 2 Honved cavalry divisions. On mobilization, 14 "march" brigades, 2 Austrian Landsturm divisions, 10 Austrian and 8 Hungarian Landsturm brigades, 17 Austrian Landsturm territorial brigades, 9 Hungarian Landsturm L. of C. brigades and 5 Austrian Landsturm march brigades, were formed in addition. During the strategic concentration a XVII. Corps was formed, and in Dec. 1914 an XVIII. In Jan. 1915 the combined Corps Krauss in the Balkan theatre (formed Sept. 1914) became the XIX., and for the spring offensive of 1916 against Italy the XX. and XXI. were formed. Later in the same year the XXII. and XXIII. came into being, and in 1917 the Saurbruch, Hofmann and Hadfy groups became the XXIV., XXV., XXVI. Corps. These 26 corps remained as such to the end of the war. All other temporary groupings, such as cavalry corps, were dissolved when this special reason for their existence ceased. The custom of temporary grouping followed by dissolution, prevailed also at the next lower echelon. Many temporary divisions existed especially in the earlier part of the war. But the order of battle was regularized in the winter of 1917-8, in connexion with the internal reconstitution of the division, and finally there were 44 army, 10 Schützen (ex K.K. Landwehr), 12 Honved divisions, and 9 army

<sup>1</sup> Of these the best known were the village riflemen of the Alps; these, known as *Standeschützen*, formed the South Tyrolean, Tirolese, Carinthian, Salzburg and Vorarlberg battalions. Volunteer rifle units were raised also in other parts of the Dual Monarchy.

cavalry, 1 Schützen cavalry (Landwehr), and 2 Honved cavalry divisions.

The subdivision of infantry divisions into brigades of two regiments remained unaltered; the cavalry divisions, however, after the reconstitution retained as a rule only one brigade staff. There were thus finally 88 army, 20 Schützen, 22 Honved, 10 Austrian Landsturm, 1 Hungarian Landsturm brigades, and 11 army cavalry, 1 Schützen cavalry and 1 Honved cavalry brigades.

The number of field artillery brigades had grown to 66. The brigade organization of fortress (heavy) artillery had practically disappeared.

The foreseen organization of the forces was in six armies, for which six general officers were designated in peace and functioned as inspectors. In Oct. 1914 the Pflanzer-Baltin group was formed in the E. Carpathians; this became the VII. Army later. In Dec. 1914 the V. and VI. Armies in the Balkan theatre were dissolved and reformed as a "Balkan Force."

In May 1915, when Italy came into the war, three new armies were created—a new V., the army group Rohr, and the III. Defence Force—under the general command of a commander-in-chief S.W. front.

About the same time the II. Army on the Russian front was dissolved, but a new III. Army was formed in the autumn for the operations under Mackensen in Serbia. This III. Army shortly moved to Tirol where, with a new XI. Army and the Tirol Defence Force it constituted a group of armies for the Asiago offensive. Shortly after that the III. Army moved again, this time to the Russian front to aid in meeting Brusilov's offensive; here, with a new XII. Army, it constituted the Archduke Karl's group of armies.

On the entry of Rumania into the war a new I. Army was created. The former I. Army on the Russian front had been dissolved in July 1916.

On the Italian front the Rohr group had meantime become the X. Army, and the Tirol Defence Force was dissolved.

In the winter of 1917, after the Caporetto offensive, a new VI. Army was created to replace the departing German XIV. Army. The V. Army had already become, in the summer of 1917, the Army of the Isonzo; for a time this army was subdivided into the I. and II. Isonzo Armies, forming the Boreovic group of armies, while the X. and XI. Armies constituted the Conrad group of armies.

In the E. nearly all armies were dissolved during 1918, first the I., then the III., IV., VII. The higher command on this side was then shared between the I., IV. and VII. "General Kommandos." The II. Army in Ukraine, however, retained its identity to the Armistice, under the name of Ku.K. Eastern Army.

In Albania, meantime, the Austro-Hungarian forces had been constituted as the Kövess army group. On the breakup of the Bulgarian front in the autumn of 1918 all available forces were constituted as one group of armies under the same general.

The End.—In Nov. 1918 the old Habsburg Empire dissolved in ruin, and with it the famous old army which had maintained its integrity through four years of trial. Its remnants formed nuclei for the national armies of the successor states. Its record was closed, and it passed into the eternity of history.

## X.—THE TURKISH ARMY

At the time of the Balkan War mobilization in 1912, Turkey possessed an army in which the officer corps represented the traditions of the Sultan 'Abdul Hamid. Everything that might make for modern efficiency in war had for 30 years been excluded from the Turkish military curriculum. Ninety-five per cent of the rank and file were illiterate; their main virtues were willingness and endurance. The officers also were in the main untrained; they were drawn either from the stupid and hidebound ranker elements (Alaîli) or from the more up-to-date products of the military schools (Mektibli); but even these latter, mostly scions of better-class families, had little sense of accuracy and punctuality in the performance of their duty. There were even general staff officers who could neither read nor write. The Young Turkish movement had the effect of placing more energetic men at the head of the troops, but had also increased military amateurishness to such an extent as to become a positive danger to the army, and to make promotion henceforward dependent, not on efficiency and professional skill, but on political intrigue. The redeeming feature of the army was the quality of the private soldier, and particularly of the Anatolian peasant. No troops in Europe were more steadfast, self-sufficient and patient. The Arabian soldiers were bad, the Kurds useless in face of the enemy and as helpless as children, the Christian and Jewish subjects of Turkey of no military value.

The term of service in Turkey was three years for all arms. Mahmud Shevket Pasha has stated that 240,000 men per year became liable for service; of these some 110,000 to 120,000 were exempted, and of the rest only about 70,000 were actually enrolled.

Official returns showed that out of a total pop of 24,000,000 (of whom at most 15,000,000 were liable for service) men from 20 to 25 years of age numbered 1,080,000, and from 20 to 40 years of age 4,000,000. The paper strength of this peace army showed 20,000 officers and 280,000 men. The total war strength of Turkey was reckoned on paper to amount to 24,000 officers, 1,300 officials, and 610,000 men. The forces actually raised in the Balkan War, however, fell far below these figures. An estimate of 450,000 men for the war army would be excessive.

The term of service was made up as follows: three years with the colours (Nizam), up to 29 years of age with the reserve (Ikkhat), thence up to 38 years of age with the Landwehr (Redif), 30th and 40th years of age with the Landsturm (Mustafâ). In war all classes, including the Mustafâ, were called up. The Ikkhat brought up the ranks of the Nizam units to war strength; this process usually absorbed them all, as the peace strength of the battalions was only some 200 to 250 men, and their arms in proportion. The Redif formed separate and complete divisions, organized in their local recruiting areas. Any man liable to service could be released after three months on payment of £50 purchasing-out fine, and was thereafter liable only to service in the older Redif classes. Thus it came about that only the poorer classes of the nation actually served in the army. There was no organization of the officers, N.C.O. and military officials not actually with the troops; so that in case of war the only reserve available consisted of the retired officers, of whom, however, as the pension was so small, very few were fit for service. The training of the men was very bad. The model units with their foreign instructors had in the short period of their existence been made to leave the mass of the army. Constant internal unrest allowed of no continued instruction. The periods of reserve training laid down by law were one month for the Ikkhat, and one month every two years for the Redif; but the absence of reserve organization and shortage of money prevented these provisions being carried out. The weakest parts of the Turkish army were the administration and the supply and transport services (provisions, clothing, material and munitions). Speculation was wide-spread, and practically all the administrative personnel were hopelessly idle. The Young Turkish régime brought no improvement. The work of the few German reformers, who under 'Abdul Hamid were never, over they were not always very suited to their task, which needed considerable tact if it were to be successfully accomplished.

When the Balkan War broke out Turkey was in the midst of her military reorganization. The greater part of the mass, who had been far too long with the colours, were being sent home; a number of Alaîli, who so far had only been mechanically instructed in the rudiments of their duties, had replaced them, so that the whole army organization down to battalions and Redif depots had been suddenly changed. The greatest confusion naturally resulted.

In place of the 7 armies hitherto existing there were formed 14 corps and 5 independent divisions (in Kozani, Yannina (Janina), Scutari, Hejaz, and Tripoli). The infantry brigades were done away with, and four divisions were formed, consisting of three infantry regiments, each of three battalions, and a field artillery regiment of two or three detachments. To each corps was allotted a rifle regiment, a cavalry brigade of 10 to 15 squadrons, 6 to 9 heavy batteries, a pioneer battalion, a telegraph company, and a train battalion. Only a few corps, however, actually possessed all these units.

The distribution of the Turkish army in the various theatres of operations in the Balkan War was as follows: Commander-in-chief, Nazim Pasha; Eastern Army (around and east of Adrianople), 'Abdalla Pasha, I., II., III., and IV. Corps and some Redif divs.; Western Army (Kamano area), Mahmud Shevket Pasha, V., VI. and VII. Corps and some Redif divs.; Southern Army (Yannina area), 'Ali Riza Pasha, 22nd and 23rd Divs.; against Montenegro (Scutari area), Hasan Riza, later Essad Pasha, 24th Div. and Elbasan Redif Division. The total strength of these forces came to barely 250,000 men. The Anatolian corps and Redif divisions only came into action in Europe after the defeat of the main armies by Bulgaria and Serbia. Soon after their arrival cholera broke out. Though it was known that the VIII. Corps was infected with this disease, none the less it was dispatched to Europe, and the authorities, in order to set public opinion at rest, stated that the epidemic was well in hand.

The Eastern Army during its occupation of the Chatalja lines lost in Nov. and Dec. more than 15,000 men, who fell victims to the plague. It may be estimated that of the 400,000 men mobilized by Turkey at least 100,000 were killed, died or were severely wounded (most of these last named may be counted as dead), i.e. 25% of the total strength.

The complete military breakdown in the Balkan War forced even the Turks to the conclusion that the time had come for undertaking serious reforms had come. For this purpose Turkey agreed with Germany that the latter should send her a large military mission under Gen. Liman von Sanders, which arrived in Constantinople in Dec. 1914. Great difficulties were met with in the task of remedying the existing defects in the Turkish military organization and training. The military mission succeeded in effecting certain changes in the organization of the army, and in breathing into it a refreshing and living spirit; but the time which elapsed between its arrival and the outbreak of the World War was too short to carry out the

necessary radical alterations in their entirety. In view of the loss of territory consequent on the Balkan War, it was necessary to remodel the whole peace organization of the army, and distribute it over the diminished area of the empire.

The total peace strength was now on paper 17,000 officers and 290,000 men, with 15,000 guns and 430 machine-guns; actually these numbers were never even approached. To each division was allotted a definite recruiting area. Area commanders were established after the German model, but did not effectively get to work prior to the World War. The organization of Redif divisions was also taken in hand; the personnel not actually called up for peace service were to form these units, which were to be utilized in time of war to complete the first line units to full strength. Great importance was rightly attached to the institution of new military schools, the inspection of which was undertaken by Liman von Sanders after he had handed over command of the I. Corps. A new Army Act became law on May 12 1914, but its provisions were never strictly enforced. Its principal clauses were: Every Turk, except for the sons of the Sultan's family, was liable to service from the age of 18. The period of service commenced on the March 1 next following the attainment of the age of 20, and extended over 25 years for infantry and train, for the other arms 20 years, and for the navy 17 years. The period of active service was in each of the above cases two, three and five years; exemptions were allowed an abridged term; physically unfit men were liable to a special tax in lieu of service. Enlarging out was allowed for five years at the expense of the rate of 500 Turkish liras; those liberated were transferred to the reserve and exempted all further liability for military duty in peace-time. Christian subjects of the empire were excluded from the ranks of the fighting troops. The War Office was reorganised from top to bottom. The great general staff was also entirely remodelled, German officers being placed at the head of the more important branches, such as those concerned with training, mobilization and intelligence.

Little or nothing could be done in the short space of time between the Balkan and European wars in the direction of rearming the army, so that the armament in the World War remained such as in the Balkan War. The infantry weapon was the 7.65-mm. Mauser repeating rifle, but older models were still partly in use. The field artillery had the 7.5-cm. Krupp field gun with second buffer and shield, 904, 1909 and 1911 models; in addition there were a few old 8.7-cm. German field guns. The mountain guns in use were the 7.5-cm. Krupp 1905 model; the Schneider 7.5-cm., which was somewhat more modern, was also in use. The heavy artillery had a number of guns of various patterns, many of which were fairly antiquated, only a few modern 15-cm. Krupp howitzers and Schneider-Creusot howitzers were available for use. Several howitzer batteries were still using smooth-bore guns, which were as good as useless on account of their short range. The fortress artillery was completely out of date, consisting as it did mainly of guns of 1880 and 1890. Moreover, lack of money prevented any steps being taken to bring the land fortresses up to date.

The Turkish forces were mobilized in the first days of Aug. 1914, but there was only a month of armed neutrality in which to prepare for war. This respite was used by Germany to equip Turkey with practically everything necessary for carrying on hostilities. Despite this German assistance the mobilization met with great difficulties. A Turkish War Office return in the summer of 1917 (which must however be accepted with caution) gave 1,478,176 as the number of recruits called up from Aug. 1914 to March 1915, 1,012,824 from March 1915 to March 1916, and 332,000 from March 1916 to March 1917. Figures as to enrolments from this latter date onwards are completely valueless. The grand total of all who served in the Turkish army from 1914 to 1918 amounted on this showing to 3,000,000 men. If we take into consideration the facts that many of these were counted twice or three times over it may be regarded as approximating to accuracy to reduce this total to 2,000,000; of whom some 750,000 deserted and 500,000 were killed or invalided out of the service in the course of the war. It is of interest to note that the officials in Turkey who were not affected by the military law, always reckoned all men called up—that is, rounded up by the police—always being of military age whether they were exempted or not. Thus it happened that many young men were exempted as not coming within the age limit of 18, while unfortunate old men and boys of 15 were given as being 20 or 30 years old, and therefore of military age.

The establishment of officers in the Turkish army reached its maximum of 30,429 in the spring of 1917; the army, however, was at its greatest strength of 1,295,621 in the previous spring. Despite great efforts and reckless use of all possible man-power resources, this total could not be maintained in 1917 in the spring of that year only 1,200,244 men were present, and from that date on the total rapidly declined.

The organization of the supreme army command was also the work of the German military mission. This was in the hands of headquarters in Constantinople. The Sultan of course held the titular post of commander-in-chief, Enver Pasha being vice-commander-in-chief. As the latter gradually assumed the political dictatorship of Turkey, divergence of views between the civil and military authorities ceased to exist.

In the first days of mobilization in Aug. 1914 the following for-

mations and organizations were in being: 4 infantry inspections, 19 general commands, 38 divisional staffs, 305 battalions infantry, 64 machine-gun companies, 115 squadrons, 211 field batteries, 124 heavy and fortress batteries, 47 pioneer companies, 4 fortress pioneer companies, 36 fortress construction companies, 42 searchlight troops (equipped with one searchlight each), 21 telegraph companies, 1 wireless telegraph company, 10 railway companies, 138 reserve squadrons, 17 service companies, 17 works troops and 51 train companies. The reserve squadrons were formed from the so-called Kurdish or Hamidie cavalry, and comprised 4 reserve cavalry divisions. They were quite untrained and of no military value. They had all the characteristics of independent nomads, and were imbued with the bitterest ill-feeling against the Armenians.

The war organization provided at first for three and in Sept. 1914 for four armies. The original armies were: I Army, Gen. Liman von Sanders, I, II, III, IV and Vb. Corps, one cavalry brigade and one battery heavy howitzers; II Army, Jemal Pasha, V Corps and (from Sept. 6 1914) VI Corps, cavalry as for the other armies, and all available heavy artillery; III Army, Hasan Izzet Pasha, X, and XI Corps; IV Army, Zeki Pasha (later Jemal), VIII, and XII Corps. The other troops of the peace army remained for the time being unorganized in armies. But even with these few armies it was not possible to bring the troops up to full war strength with the reserves available; some companies were barely 100 strong even in Jan. 1915. During the later stages of the war Enver's policy of limiting the formations to a few well-organized corps and armies was given up; new formations were constantly being ordered and old ones broken up or remodelled. For these the available man-power, armament and equipment were insufficient, so that the whole army became completely disorganized.

During the war the number of the armies was increased to nine. The army leaders were continually being given other troops, and having to give up divisions and corps, so that their armies were constantly growing smaller. Thus the I. Army, which in 1914 was over 200,000 strong, had sunk by 1917 to about 3,000 men, and the II. Army by 1918 to 5,000 men, and in 1918 there were in Palestine three Turkish armies, none of which were stronger than an English infantry division. All the armies, corps and divisions, however, still kept up their enormous staffs.

The number of officers in the German military mission increased in 1916 to 200, in 1917 to 800; a large number of other ranks, mostly of the technical services, must be added. Of complete German units the personnel of a few batteries at the Dardanelles and the crews of the "Goeben" and "Breslau" fought with the Turkish army. Enver shrank from employing larger units, and in principle stood out against it. Only the so-called "Yildemir" (known to the Germans as "F") Group consisted entirely of German troops. (F. C. E.)

**ARMY MEDICAL SERVICE (UNITED KINGDOM).**—The British Army Medical Service never had such a task imposed on it as during the World War, from which it emerged with its organization tested by fire. Its duties cover the care of the sick and wounded of the military forces, the preservation of their health, the supply of medical and surgical material, the maintenance and administration of military hospitals and the command of patients in the unit, the medical examination of recruits and invaliding of men unfit for further service, the education and training of its own personnel, and the strategical and tactical employment of a variety of medical units concerned with the collection, evacuation and distribution of casualties in war.

Until 1873 the functions of an Army Medical Service had been carried out by a regimental system under which medical officers belonged to and wore the uniform of the regiments to which they were gazetted, and under which many of the sick and wounded were cared for in regimental hospitals. Soldiers enlisted in the combatant ranks were trained in hospital duties and formed a Medical Staff Corps, but they were not under the command of the medical officers. In 1861 "Medical Staff Corps" was changed to "Army Hospital Corps," but the pay and discipline of the men were directly under the department of the purveyor-in-chief, and medical officers had no military position until 1869, when the director-general for the first time was attached to the military department of the War Office on the recommendation of a committee presided over by Lord Northbrook. In 1878 the personnel of the Army Hospital Corps was recruited by direct enlistment. In 1883 a committee under Lord Morley, after the Egyptian War, recommended that the Army Hospital Corps and the officers of the Army Medical Department should be merged into a "Royal Medical Corps," but this recommendation was not adopted at the time. A compromise was made by forming the officers into a body called the "Medical Staff" and the men into a corps called the "Medical Staff Corps," their

original name. At the same time the officers of the Medical Staff took complete command over the personnel of the Medical Staff Corps, and their uniform was assimilated to that of the latter. Eventually, after considerable agitation on the part of the medical profession, Lord Lansdowne, then Secretary of State for War, announced, at a banquet given by the Lord Mayor of London on May 4 1898 to the medical profession, that the Medical Staff and the Medical Staff Corps in future would be consolidated into one corps, namely the Royal Army Medical Corps (R.A.M.C.), with military ranks and titles from private to colonel similar to those of other branches of the army. The ranks above colonel, however, retained the title of surgeon-general until 1918, when this title was abolished and replaced by that of major-general or lieutenant-general.

#### PEACE ORGANIZATION

**Administration.**—The director-general of the Army Medical Service is the administrative head. He has the rank of lieutenant-general. His office is a branch of the adjutant-general's department at the War Office. He is not, however, a member of the Army Council, but may be required to attend council meetings when his advice is desired on any special subject. His staff consists of a deputy director-general, who is a major-general, eight officers of the rank of colonel, lieutenant-colonel or major (some of whom hold temporary appointments only consequent on the World War) as assistant and deputy assistant directors-general, and colonels-on-the-staff or major-generals as directors of hygiene and pathology. The directors of hygiene and pathology have deputy directors, assistant directors and deputy-assistant directors of hygiene and pathology as assistants in their directorates. The administration of the Queen Alexandra's Imperial Military Nursing Service (Q.A.I.M.N.S.) also forms a branch of the director-general's office under the matron-in-chief assisted by two principal matrons and a nursing sister. In 1921 an inspector of dental services was added to the director-general's staff on the formation of an Army Dental Corps, with the rank of lieutenant-colonel.

The director-general's administration is assisted by an inspector of medical services, who is either a colonel or major-general of the Army Medical Service. He visits all stations at home and overseas with a view to maintaining a uniform standard of training and efficiency. He reports to the adjutant-general.

In all commands at home and overseas the director-general is represented by deputy-directors and assistant-directors of medical services. In some of the smaller garrisons the senior executive medical officer acts in an administrative capacity without being graded as a deputy or assistant director. The staff of these administrative offices varies according to the size and importance of the command or the conditions under which troops are serving. Thus in the small garrisons in the tropics where medical research is of importance there is a deputy assistant director of hygiene and pathology, although the administration may be in the hands of a senior medical officer only. In India there is a special administration for the Army Medical and Indian Medical Service. Officers of the latter, when employed on military duties, are under the administration of a director of medical services, who is a major-general or lieutenant-general of the Army Medical Service, but the administrative appointments of the subordinate military commands in India may be held either by Army Medical or Indian Medical deputy directors and assistant directors. In war establishments there is a director of medical services in the headquarters of each army, a deputy director with each corps and an assistant director with each division. On their staffs are representatives of the directors of hygiene and pathology and other assistants.

**Advisory Boards.**—Connected with Army Medical administration there are several advisory boards or committees composed of military and civil members. An Army Medical Advisory Board advises on general professional questions. It is presided over by the director-general and its members are two consulting physicians, two consulting surgeons, the medical officer of the India Office and an officer of the Royal Army Medical Corps. An Army Hygiene Advisory Committee is presided over by the director of hygiene. Its members include an officer of the Royal Engineers (R.E.) and

of the Royal Army Service Corps (R.A.S.C.), and military and civil sanitary experts. An Army Pathology Advisory Committee under the director of pathology is similarly composed of military and civil pathologists of eminence who deal with technical questions connected with research into the causes of disease. Queen Alexandra's Army Nursing Board, of which Queen Alexandra is president and the director-general chairman, is composed of the matrons-in-chief of Q.A.I.M.N.S. and Territorial Force Nursing Service, of matrons of some of the large civil hospitals and of ladies nominated by the president. There is also a Technical Advisory Committee on Voluntary Aid under the director-general. It is composed of representatives of the War Office, British Red Cross Society, Scottish Branch of the Red Cross Society, the council of County Territorial Force Associations, and the St. John and St. Andrew's Ambulance Associations. These boards and committees meet at the War Office.

**Personnel.**—The personnel of the Army Medical Service consists of officers, warrant officers, non-commissioned officers and men of the R.A.M.C. regular, special reserve, and territorial force, and of the Army Dental Corps, together with the affiliated nursing services of the regular army and territorial force, and the voluntary organizations recognized by the British Government under Article 10 of the Geneva Convention of 1906. The ranks of officers and men are the same as for other branches of the service. Officers and other ranks of the regular R.A.M.C. are under an obligation to serve in all parts of the world in peace or war; but only the officers serve in India, where the duties of subordinate ranks are carried out by a special Indian establishment consisting of an Indian Subordinate Medical Service, an Army Hospital Corps and an Army Bearer Corps. The members of the last two are natives of India. The members of the Indian Subordinate Medical Service are Indian-born British or natives of India educated in Indian medical schools. The higher grades rank as commissioned officers and the lower as warrant officers. The special reserve is organized on a militia basis and serves on embodiment under the same conditions as the regular Royal Army Medical Corps. The Territorial Force R.A.M.C. is organized for war purposes only. It has a general list of officers for service with regimental and medical units, a special list for territorial force general hospitals; and another for sanitary services. The rank and file of the regular R.A.M.C. are formed into companies, of which in 1921 there were 35, in addition to four depot companies. Eleven of the companies had their headquarters in overseas garrisons. Both at home and overseas the headquarters of R.A.M.C. companies are at one or other of the larger military hospitals. They provide detachments for smaller hospitals and general duty. The number in each company varies in accordance with local requirements. The normal peace establishment of the regular R.A.M.C. on the active list is approximately 1,100 officers and 3,800 other ranks, but this is greatly expanded in time of war by calling up reserves of every description. During the World War it had expanded to some 15,000 officers and 120,000 other ranks, in the case of officers chiefly by granting temporary commissions to members of the civil profession.

**Training.**—The depot for training the regular R.A.M.C. is at Aldershot. Territorial Force R.A.M.C. are trained in a school of instruction in each of 12 territorial divisions by officers of the regular R.A.M.C., who act as adjutants of the schools. There is a R.A.M. College in London, where officers of the regular R.A.M.C.; both on joining and before promotion to major, undergo a course of instruction in military hygiene, tropical diseases and other professional subjects. Training in field duties is carried out in the form of staff tours, camps of instruction and medical manoeuvres. Training in sanitation is carried out in an army school of hygiene at Aldershot and in schools of hygiene established in commands.

**Military Hospitals.**—Military hospitals are established in all commands at home and abroad. They vary in size from large general hospitals, such as the Royal Victoria hospital at Netley with over 1,000 beds, to small depot hospitals and detention wards in outlying posts. The number of beds normally maintained in peacetime in the United Kingdom is approximately seven thousand. In the World War this number expanded to more than 364,000; or, including beds in all theatres of war, to over 640,000.

**Medical Stores.**—An Army Medical Store is maintained at Woolwich for the supply of medical and surgical material and equipment to all garrisons at home and overseas, with the exception of India, which has its own stores. Supplies are obtained by contract from manufacturing firms. They are distributed through the central stores at Woolwich.

#### WAR ORGANIZATION

The organization of the Army Medical Service for war does not come into existence until mobilization is ordered. Medical units, the equipment for which is maintained in mobilization stores, are then brought into being by the assembly of personnel, material and transport at places of mobilization assigned to each unit. Three zones of medical work are recognized: The collecting zone, the evacuating zone, and the distributing zone. In these zones there are medical services for the collection, transport and treatment of sick and wounded, for the supply of medical



and surgical stores, and for sanitary duties. Sick and wounded are collected in the first instance by a regimental medical service and passed from it to the field ambulances of the divisions. They are cleared from the divisions by motor ambulance convoys, which convey them to casualty clearing stations, whence they are passed down the lines of communication by rail, canal or road to the permanent hospital bases, and from there by sea-going hospital ships to the hospitals in the United Kingdom. The collecting zone may be regarded, therefore, as the area of work back to the casualty clearing stations; the evacuating zone as the lines of communication down to the sea bases or to the United Kingdom, and the distributing zone as the area of the hospital bases and the home territory.

**The Regimental Medical Service.**—Each regiment of cavalry, battalion of infantry, brigade of artillery, ammunition column, squadron or bridging train of engineers and certain supply trains has an officer of the R.A.M.C. attached to it, together with a small detachment of R.A.M.C. other ranks for technical charge of water and other supplies. Sixteen members of the regiment are placed under his command as stretcher-bearers; and a non-commissioned officer and eight men, trained in sanitary duties, also work under him. Wounded are collected to a regimental aid post, which is established by the medical officer in a shelter or protected spot near regimental headquarters.

**Field Ambulances.**—There are two forms of ambulances, the cavalry field ambulance for cavalry divisions and the field ambulance for divisions. They differed considerably in organization and transport before the World War, but since then the chief difference is in their transport. A cavalry division has a cavalry field ambulance for each brigade of which it is composed. Thus a cavalry division of four cavalry brigades would have four cavalry field ambulances. Divisions have three field ambulances each. Both a cavalry field ambulance and a field ambulance are composed of a bearer division and a tent division, and are organized in two sections, each section being formed of half the bearer and half the tent division. In the bearer division there are 18 stretcher detachments. They bring wounded back from the regimental aid posts to an advanced dressing station formed by one of the tent subdivisions at a point to which a motor transport applies. Wounded are conveyed from the advanced dressing station to a main dressing station formed some distance back by the remainder of the field ambulance or by other field ambulances where there is less exposure to enemy fire than at the advanced dressing station. Formerly both classes of ambulance had each 10 horse-drawn ambulance wagons, six of which in cavalry field ambulances were light wagons, the remaining four being heavy wagons of the same type as the 10 wagons of the field ambulance. Motor ambulance cars replaced a proportion of the horse-drawn wagons after the British Expeditionary Force moved from the Aisne to the Flanders front in 1914. The ambulance transport of the cavalry field ambulance now consists of four motor ambulance cars and six light horse-drawn ambulance wagons; that of the field ambulance is seven motor ambulance cars and two heavy horse-drawn ambulance wagons. They are employed in battle in carrying wounded from the advanced to the main dressing station, but may go forward in advance of the former where it is possible to do so. Their carrying capacity is two lying or eight sitting in the light wagon or light ambulance car, and four lying or 12 sitting in the heavy wagon or motor ambulance car. Field ambulances are divisional troops, and come under the command of the assistant director of medical services of the division.

**Motor Ambulance Convoys.**—The first motor ambulance convoy used by the British in war was organized at the end of Sept. 1914 during the battle of the Aisne. It was formed of ambulance cars sent to France by the War Office early in Sept. and was rapidly followed by similar convoys, some of which were provided by voluntary organizations. Previously the system by which sick and wounded were brought from the field ambulances to railhead was to load them in the lorries of the supply columns returning empty to refill. But the system broke down early in the World War partly because this form of transport subjected the wounded to serious discomfort and jolting, and partly because the requirements of supply services and medical services were in conflict with one another. A motor ambulance convoy consists of 50 motor ambulance cars; it is under the command of an officer R.A.M.C. with R.A.M.C. personnel for medical duties, and a R.A.S.C. personnel, under an officer R.A.S.C., as drivers and mechanics. The number of these convoys allotted to an army is usually in the proportion of one for each army corps of which the army is composed, and one as an army reserve. They are normally army troops under the control of the director of medical services, who may, however, place them at the disposal of deputy-directors of army corps. Their function is to clear the field ambulance main dressing stations of sick and wounded to casualty clearing stations at or near railheads, and to perform all other ambulance transport duties by road not carried out by the transport of field ambulances. In the event of railway transport breaking down or proving insufficient to relieve congestion of sick and wounded in the front areas,

motor ambulance convoys may be employed for conveying sick and wounded to hospitals at the base.

**Casualty Clearing Stations.**—These are medical units which form the link between the collecting and evacuating zones, or between the division of the field army and lines of communication. Their function is to receive the sick and wounded from the divisional field ambulances. Sick and wounded likely to be fit for duty after a short period of treatment are retained, as are also those too seriously ill for further transport. The remaining sick and wounded, after receiving temporary medical and surgical treatment, are evacuated as rapidly as circumstances and railway transport permit to the hospitals at the base. Casualty clearing stations are consequently organized with a convalescent or lightly wounded section, a hospital section, and an evacuating section. The number of casualty clearing stations allotted to an army is in the proportion of one for each division, but they are essentially strategical units and are army troops, the director of medical services being responsible for placing them where they may best receive and evacuate the number of wounded anticipated in battle. They are mobilized with personnel and equipment for the care of 200 casualties at a time, but are capable of expansion to any extent in the field from local resources or by bringing up additional equipment and stores from the base, whenever the nature of the operations admits of this being done. The organization of casualty clearing stations, therefore, depends very much on the nature of the military operations. The general principle upon which it is based is the mobilization of a light mobile unit in the first instance capable of following up an advancing army with sufficient equipment and shelter for surgical work at an advanced operating centre, and adding to it more extensive accommodation and equipment whenever circumstances permit. In its original composition a casualty clearing station had no transport of its own. During the World War three 3-ton lorries were allotted to it. It was customary to group them in twos or threes in the same locality. The lorries of a group of three casualty clearing stations would thus be sufficient to carry forward the advanced operating section of one of the three, and then return for the others. The weight of the original equipment, including marquees for 200 patients, was 21 tons, so that the nine lorries were capable of carrying this load. The heavier equipment and more extensive accommodation added during stationary warfare required 50 to 60 lorries for moving a casualty clearing station by road, or a complete train by rail. Casualty clearing stations are allotted two 3-ton motor lorries each.

**Ambulance Trains.**—The evacuation of wounded by railway is effected by special trains constructed by the military authorities. The former are composed of ambulance coaches with through communication and accommodation varying from 300 lying down to 600 sitting up. They are commanded by an officer of the R.A.M.C. and are administered by the director of medical services on the lines of communication, whose staff regulate their journeys in association with the railway transport staff and in accordance with the demands of the field army. They are mobilized as a rule in the proportion of one for each division in the field, but their number depends on the length of the journeys from front to base and the time taken to return. Improvised ambulance trains are made up of passenger coaches or goods vans specially fitted for carrying sick and wounded. The ambulance trains were of this kind at the beginning of the World War, and were organized to carry 396 lying down on stretchers placed on special frames constructed to carry three stretchers each. Four frames were placed in each of 33 goods vans. Improvised trains subsequently were used in emergency only and were usually in the form of passenger coaches for transport of patients sitting up. When these improvised trains are used rest and refreshment stations are opened at intermediate halting places for supplying food and comforts and for removing patients unfit to continue the journey and transferring them to local hospitals. Rest stations for attending to patients pending their removal to hospital are also opened at stations where all classes of ambulance trains unload. They are formed by detachments from hospital units or by voluntary aid.

**Ambulance Flotillas.**—Although ambulance flotillas of river steamers or barges are war establishment units of continental armies, they are not definitely organized units of the British Army. They were formed, however, in 1914-8 for use on the canals in the north of France, and were composed of barges specially equipped as hospital wards and towed by steam tugs. Each barge had 30 beds, kitchen and stores, and accommodation for a staff of one medical officer, two nursing sisters and nine R.A.M.C. orderlies. Six barges formed a flotilla, and four flotillas were organized. They brought seriously wounded from casualty clearing stations to such hospitals on the lines of communication as were on or near a canal.

**Hospital Ships.**—Passenger or other ocean-going ships are chartered in time of war and fitted out as hospital ships for evacuating sick and wounded from the sea bases of a theatre of war to the United Kingdom. Their number and carrying capacity depend on the nature of the campaign, but the most suitable are those which are neither too large nor too small. A ship carrying 600 to 800 patients in cots was regarded as the best during the World War.

**Hospitals** are of two kinds, general and stationary. The former are fully equipped for all kinds of medical or surgical work. They are organized for 500 to 1,000 hospital beds, the smaller in the proportion of two and the larger in the proportion of one for every division in the

field. They are situated at or near the sea bases but may be established in greater or smaller hospital centres elsewhere on the lines of communication. The stationary hospitals are smaller and less fully equipped than the general hospitals and are organized for 200 or 400 beds. They are intended to act as local hospitals for the sick of large camps or other posts on the lines of communication, or as hospitals for special purposes such as the reception and treatment of infectious diseases. They are mobilized in the same proportion as general hospitals. In the United Kingdom the Territorial Force R.A.M.C. mobilize 24 general hospitals in time of war, each of 520 beds.

**Convalescent Depots.**—These form large camps at the bases or elsewhere where convalescents on discharge from hospital are made physically fit to return to duty by convalescent treatment and graduated physical training. There is no fixed limit to their numbers or size. During the World War a convalescent depot could accommodate from 1,000 to 5,000 men.

**Medical and Surgical Supplies in War.**—Two kinds of units are organized for maintaining and distributing medical and surgical supplies, the base depots of medical stores and the advanced depots. They are in charge of quartermasters of the R.A.M.C. The base depots receive their supplies through the Army Medical Stores at Woolwich. They supply the hospitals and medical services at the base and on the lines of communication, and are placed as a rule at the sea bases. Originally the proportion was one for every two divisions, but there was no fixed proportion during the World War. As a rule there was one at each sea base or advanced base. Advanced depots of medical stores are army troops under the control of the director of medical services of the army, and are allotted in the proportion of one for each army corps. They are replenished from the base depots and supply the casualty clearing stations, the divisional medical units and other medical services of the field army.

**Sanitary Organization in War.**—In addition to the sanitary detachment of each regimental unit, a sanitary section of one officer and 25 men is mobilized with each division and for each base. Sanitary squads of one non-commissioned officer and four men are also mobilized for each railhead or railway post on the lines of communication. The personnel of sanitary sections and squads act as sanitary inspectors, supervise the construction of sanitary requirements in camps and billets, and maintain sanitary establishments.

**Mobile Laboratories.**—For special work in the field four classes of mobile laboratories are organized. Mobile hygiene laboratories for chemical analysis of water and food supplies and for other hygienic investigations are allotted in the proportion of one to each army. Mobile bacteriological laboratories for medical and surgical bacteriological investigation are allotted in the proportion of two to each army. A mobile X-ray laboratory and a mobile dental unit, in the proportion of one of each to an army, are attached to one of the casualty clearing stations. All these laboratories are constructed on motor chassis and can be placed in any area as required.

**Nursing Services in War.**—Members of the nursing services are employed in all the general and stationary hospitals, in ambulance trains and flotillas, hospital ships and casualty clearing stations.

**Voluntary Organization in War.**—Voluntary aid detachments of men and women are organized under County Territorial Force Associations by county directors of the British Red Cross Society or St. John Ambulance Association. They have a definite composition and are registered at the War Office. On mobilization they undertake the opening and staffing of auxiliary hospitals throughout the United Kingdom and the local transport of patients who are being distributed to hospitals in the United Kingdom. Members of women's Voluntary Aid Detachments (V.A.D.) may also be employed in nursing duties in military hospitals. In theatres of war the chief function of voluntary aid organizations is to maintain stores for supplementing hospital equipment and supplies by articles which may add to their comfort and appearance, and by distributing gifts. Medical units offered by voluntary services or private individuals are not recognized unless they are organized on the same lines as corresponding regular units and under the command of officers of the R.A.M.C. In addition to the voluntary aid detachments, the St. John Ambulance Brigade and the St. Andrew's Ambulance Association maintain a home hospital reserve, the personnel of which takes the place of the regular R.A.M.C. in the military hospitals in the United Kingdom when the latter are mobilized to form the medical units of the war establishments. At the beginning of the war in 1914 the St. John Ambulance Brigade had ready a home hospital reserve of 200 men and the St. Andrew's Ambulance Association 113, but these numbers increased so rapidly that by the end of 1915 over 15,000 of the St. John Ambulance Brigade were serving in the military hospitals in Great Britain. (W. G. M.A.)

**UNITED STATES**

**Functions.**—By Army Regulations the Medical Department in 1910 was charged with the following duties: Investigating the sanitary conditions of the army and making recommendations with reference thereto; advising with regard to the location of permanent stations, the selection and purification of water supplies, and the disposal of wastes; caring for the sick and wounded;

making physical examinations of officers and enlisted men; managing military hospitals; recruiting, instructing and controlling the enlisted force of the Medical Department and the Nurse Corps, and furnishing all medical and hospital supplies except for public animals. In 1921 these functions persisted.

#### COMPOSITION

**Medical Department.**—In 1911 the Medical Department comprised the Medical Corps, Medical Reserve Corps, Dental Corps, Hospital Corps (male), and Nurse Corps (female), to which could be added contract surgeons and other civilians. The National Defense Act of 1916 provided that the Department should consist of "one surgeon-general, . . . who shall be chief of said department, a Veterinary Corps, a Medical Reserve Corps, . . . a Dental Corps, a Medical Corps, an Enlisted Force, the Nurse Corps, and contract surgeons . . ." Subject to the appointment of great numbers of officers in temporary grades up to and including that of major-general, as authorized by war legislation, this Act covered the organization of the medical service during the World War, with the exception that a new temporary body was formed which was known as the Sanitary Corps and consisted of officers and enlisted men, not graduates in medicine, who possessed knowledge or experience of value to the Medical Department. The Act approved June 4 1920 stipulated that the surgeon-general should have the rank of major-general and should have two assistants with the rank of brigadier-general; it added a new branch, the Medical Administrative Corps; under this Act the enlisted strength of the Medical Department could not exceed 5% of the actual commissioned and enlisted strength of the army; the number of officers in the Medical Corps was fixed at 6.5 for every 1,000 of "authorized" (virtually actual) enlisted strength of the regular army.

As provided by Act of April 23 1908, the Medical Corps of the army consisted of one surgeon-general with rank of brigadier-general, 14 colonels, 24 lieutenant-colonels, 105 majors and 300 captains or first lieutenants, advancement being by seniority except in the case of lieutenants, who were promoted after three years' service. The scheme for promotion was modified by the Act approved June 4 1920, to provide that officers of the Dental and Medical Corps should be promoted to the grade of captain after three years' service, to the grade of major after 12 years' service, to the grade of lieutenant-colonel after 20 years' service, and to the grade of colonel after 26 years' service, all subject to the satisfactory passing of the required examinations. On Oct. 1 1921 there were 45 colonels, 87 lieutenant-colonels, 483 majors, 474 captains, and 51 first lieutenants.

Beginning with 1901 the Medical Department employed civilian dentists under contract. The Act of March 3 1911 established a Dental Corps, consisting of lieutenants in the proportion of one to each 1,000 of actual enlisted strength of the army, but in no event to exceed 60. By an Act approved Oct. 6 1917 the Corps was made to consist of officers of the same grades and proportionate distribution of grades as were then, or as might thereafter, be provided by law for the Medical Corps. On Oct. 1 1921, there were in the Dental Corps eight colonels, 15 lieutenant-colonels, 62 majors, 132 captains and 25 first lieutenants. The Veterinary Corps was established by the National Defense Act and took over the veterinarians formerly assigned to mounted regiments and to the Quartermaster Department. On Oct. 1 1921 there were in the Veterinary Corps four colonels, six lieutenant-colonels, 17 majors, 25 captains, 97 first lieutenants and six second lieutenants. The Medical Reserve Corps was established by Act of April 23 1908 for the purpose of securing a supply of medical officers available in emergency. The National Defense Act abolished the Medical Reserve Corps, as such, and established an Officers' Reserve Corps, with sections corresponding to the various arms, staff corps and departments of the regular army. Under this law a medical section of the Officers' Reserve Corps, containing approximately 1,250 physicians, existed at the outbreak of the World War. On Oct. 14 1921 there were 5,816 officers enrolled in the medical section of the Officers' Reserve Corps, 3,747 in the dental section, 390 in the veterinary section, 264 in the sanitary section, and 491 in the medical administrative section. A Hospital Corps, composed of hospital stewards and privates, was established by Act of March 1 1887, which directed that all necessary hospital services in garrison, camp or field, including ambulance service, should be performed by members of this corps, which was permanently attached to the Medical Department. The National Defense Act abolished the designation "Hospital Corps" and substituted therefor an Enlisted Force, consisting of non-commissioned officers, privates first class, and privates. The Army Nurse Corps (female) came into existence in 1901. No appreciable change in its organization was made until the Act of June 4 1920, when the members of the Nurse Corps were given relative rank, the superintendent having that of major, the assistant superintendents that of captain, chief nurses that of first lieutenant, and head nurses and nurses that of second lieutenant. In respect of matters within the line of their duties, nurses were given authority, in and about military hospitals, next after officers of the Medical Department. Nurses in 1921 continued to be employed under contract for a period of three years, and did not receive the pay of their relative rank. The Medical



**Administrative Corps** was established by the Act approved June 4, 1920. Appointees therein must have had enlisted service in the Medical Department. These officers act in the capacity of adjutants, mess officers, registrars, property officers, commanders of detachments, and the like, in medico-military units, thereby relieving medical officers of the necessity of performing these essential but non-professional duties.

**National Guard.**—The organized militia, known as the National Guard, possesses a medical department consisting of a medical corps, dental corps, veterinary corps and enlisted force, conforming in organization, discipline and equipment to like units of the Medical Department of the regular army. The personnel, known collectively as sanitary troops, is divided into three groups: (a) those assigned to combatant units; (b) those organized into sanitary units such as medical regiments, hospital companies and ambulance companies; and (c) those belonging to state staff corps and departments.

#### PEACE-TIME ORGANIZATION

**Surgeon-General's Office.**—Whether in peace or war, the surgeon-general's office in Washington is one of the coordinate bureaus of the War Department which function under the Secretary of War through the intermediate channel of the chief-of-staff. The surgeon-general advises the War Department in matters relating to his bureau, coordinates all technical activities of the Medical Department through corps area or department surgeons, originates medical policies, compiles medical statistics, distributes personnel to the corps areas and geographical departments, and directly controls all matters relating to the purchase of supplies and the expenditure of appropriations for construction and repair of hospitals and employment of civilians. These functions did not change materially in character between 1910 and 1921 but the work expanded greatly; then the duties were divided between four divisions:—Personnel, Supply, Sanitation, and Museum and Library; the organization on Oct. 1, 1921, included the following eleven divisions, each being staffed with one or more officers specially selected because of their knowledge of the subjects handled: Administrative; Coordination, Organization and Equipment; Dental; Finance and Supply; Hospital; Library; Personnel; Sanitation; Statistical; Training; Veterinary.

**Aviation Service.**—Detailed administration of Medical Department matters relating to aviation is handled by a medical officer attached to the staff of the chief of the air service.

**Department and Corps Area Surgeons.**—The continental United States is divided for administrative purposes into nine "corps areas," and the outlying possessions into three departments (Hawaiian, Philippine, and Panama Canal). A department or corps-area surgeon, as one of the staff of the commanding general of each department or corps area, presides over the medical activities therein.

**Station Personnel.**—At all military stations, other than general hospitals, medical officers and a suitable detachment of enlisted men of the Medical Department are assigned to care for the troops and to administer the station hospital, which usually provides beds for at least 3% of the forces. If the command is part of a tactical unit some or all of these medical officers and enlisted men are normally attached to the combatant troops in preparation for active service.

**General Hospitals.**—Large institutions, known as "general hospitals," are maintained (a) to afford better facilities than can be provided at station hospitals for the observation and treatment of obscure, complicated and serious cases, (b) to instruct and train junior officers, nurses and enlisted men, and (c) to furnish a nucleus for expansion in time of war. In 1910 there were four such hospitals in the United States army, which number in 1921 had been increased to six.

**Education, Training and Investigation.**—The Army Medical School, Washington, D. C., was established in 1893 with the object of training students in the duties which pertain to the Medical Department. The student body consists of officers of the Medical Corps, the Medical Reserve Corps and the National Guard, and of enlisted men in the Medical Department. From 1910 to 1919 the regular course covered about eight months, but it was shortened and instruction in the non-medical features of a complete medico-military curriculum transferred to the Medical Field Service School, established in 1920 at Carlisle, Pa.

#### WAR-TIME ORGANIZATION

**Object of the Medical Department in War.**—The objects of Medical Department administration in war are: First, the preservation of the strength of the army in the field by (a) the institution of requisite sanitary measures for preventing avoidable sickness; (b) the retention of effectives at the front; and (c) the prompt succour of wounded on the battlefield and their removal to the rear, thus preventing the unnecessary withdrawal of combatants from the firing line to accompany them. Second, the care and treatment of the sick and injured in the zone of the advance, on the line of communications, and in the home territory. Third, the promotion of general morale among the troops through the knowledge that efficient medical and surgical attention is immediately available.

**Voluntary Aid and the Red Cross.**—Organized voluntary aid may be utilized to supplement the resources and assist the personnel of

the Medical Department only through the American National Red Cross. Before military patients are assigned to establishments maintained by the Red Cross Society these establishments will be placed under the immediate direction of a medical officer of the army.

**Administrative Organization in the Theatre of Operations.**—The theatre of operations is divided into (a) the combat zone, including division areas, corps areas and army areas; (b) the communications zone, including all territory from the rear of the combat zone to and including the base. In a large expeditionary force a chief surgeon coordinates all Medical Department activities of the force, including the combat and communications zones; he organizes his office on the basis described above for the surgeon-general's office.

**Communications Zone.**—The chief surgeon of this zone, as a member of the staff of the commanding officer thereof, exercises immediate control over the Medical Department units therein, such as station and general hospitals, supply depots, training schools, central laboratories, hospital trains, boats and ships, ambulance parks, etc. The function of the Medical Department in the zone of communication is medical procurement, storage and supply, care of the troops within its area, evacuation of sick and wounded, and definitive hospitalization. The following are the more important units: The general hospital (formerly termed base hospital) is for definitive treatment, having a normal capacity of 1,000 beds but capable of crisis expansion by tentage to 2,000. These institutions provide every facility for the care of the sick and wounded; certain ones specialize on particular classes of injuries or diseases. The authorized personnel consists of 40 officers, 120 nurses and 312 enlisted men of the Medical Department. The station hospital (formerly styled camp hospital) has a standard capacity of 300 beds and serves the immediate local needs of troops belonging to the communications zone. The personnel consists of 13 officers, 35 nurses and 100 enlisted men of the Medical Department. A hospital train consists of 16 cars accommodating 350 enlisted men, with a Medical Department personnel of four officers, 40 enlisted men, and 600 nurses as required.

**Combat Zone.**—The area covered by this zone includes the troops which are organized into divisions, corps and armies. The Medical Department personnel pertaining to an army, to a corps or to a division is administered by an army, corps or division surgeon respectively, under supervision of the surgeon of the next higher unit. The functions of the surgeon are coordination, supervision and control of the medical service at all times and during combat particularly the relief or reinforcement of the actively engaged Medical Department units by means of army, corps or divisional troops. The work concerns itself only with sanitation, care of troops, collection of casualties and temporary hospitalization.

**Army and Corps Medical Department Troops.**—To an army, in addition to its administrative medical personnel, there are attached four medical regiments, 13 evacuation hospitals, 12 surgical hospitals, one convalescent hospital, one army laboratory, three army supply depots, three army veterinary evacuation hospitals, and one veterinary convalescent hospital; collectively these form part of the army troops. The 13 evacuation and 12 surgical hospitals are for the temporary care of non-evacuable cases and the convalescent hospital is for those practically well and needing little attention, but not yet ready to return to duty. A corps has an administrative medical organization similar to that of an army but smaller; it has one medical regiment as part of its corps troops. The evacuation hospital has the primary function of taking over patients from divisional (field) hospitals, established by the hospital companies of a medical regiment, so that these mobile units may move with their divisions; provision is made for very complete surgical treatment if necessary. The capacity is 750 beds and the personnel 38 officers, 50 female nurses and 281 enlisted men. The surgical hospital supplements the evacuation hospital for the purpose of handling near the front those cases requiring immediate operation. The bed capacity is 250 and the personnel consists of 19 officers, 20 female nurses and 90 enlisted men. The convalescent hospital has a bed capacity of 5,000 and a personnel of 21 officers and 153 enlisted men.

**Medical Department Troops Attached to a Division.**—The infantry division, which is a basic tactical unit, has a Medical Department personnel of 148 officers and 1,375 enlisted men. Part of these are directly attached to combatant units; the remainder belong to the medical regiment. The regimental medical personnel cares for the sick and injured in camp and on the march; supervises local sanitation; goes into action with the troops; and establishes battalion or regimental aid stations where wounded are collected and given temporary care. The medical regiment, replacing the sanitary train of the pre-war period, consists of a sanitary battalion, an ambulance battalion with 40 motor and 20 animal-drawn ambulances, and a hospital battalion of three hospital companies, each operating a field hospital of 200 beds capacity. The personnel consists of 68 officers (medical, dental and veterinary) and 840 enlisted men. The medical regiment of a division provides personnel for the division surgeon's office and for sanitation of the division area, collects wounded men by litter from the front, from the divisional and regimental aid stations and transports them to the ambulances, maintains wheeled transportation service for movement of casualties, supplies temporary hospitalization, procures and issues medical supplies for the command, renders laboratory service and collects, treats and temporarily hospitalizes sick animals.

## THE DEPARTMENT'S WORK IN THE WORLD WAR

**Sanitary Achievements.**—The value of a medical service in war should be measured, first, by the degree to which it preserves the effective strength of the army by sanitary methods, and, second, by its success in evacuating and caring for the sick and wounded. In both respects the Medical Department of the American army attained notable results. The success in preventing infectious diseases and losses from them, as compared with the Civil and Spanish-American Wars, is shown by the fact that only 6,445 fatalities occurred as a result of typhoid fever, malaria, dysentery, smallpox, scarlet fever, diphtheria and other miscellaneous communicable diseases (excluding tuberculosis and pneumonia), whereas if the Spanish War rates had prevailed there would have been 101,439 deaths, and if the Civil War rate had prevailed there would have been 170,997 deaths from these causes.

**Care of Sick and Wounded.**—In the succour of the sick and wounded great advances were made both in the theatre of operations and in the service of the interior. Personnel directly attached to combatant organizations was greatly increased. Mobile surgical hospitals were organized and operated close to the front; X-ray examinations were everywhere available; splints for use in transporting fracture cases were enormously improved. Motorization of ambulance service was carried to an extent hitherto undreamed of. Base hospitals were enlarged to accommodate 1,000 patients or more, and were frequently grouped in centres, sometimes aggregating 20,000 beds, including the crisis expansion under canvas. In such centres the individual hospitals specialized, one treating gassed cases, another head cases and others chest wounds, fractures, abdominal injuries and medical patients respectively. Laboratory service both at the front and on the lines of communication was expanded beyond all precedent. Professional services were more carefully coordinated and supervised than ever before; the most expert personnel was divided into groups, such as operating teams, gas teams, shock teams, etc., for quick transport by automobile or train to points where need was greatest. Veterinary units were augmented in size and number, caring promptly for sick and wounded animals. In the zone of the interior hospital service was brought to the highest standard, the best professional talent of the country was mobilized, and notable progress was made in the treatment of the sick and injured, particularly in the direction of physical reconstruction of the wounded, with a view to returning the individual to the community as a self-sustaining citizen.

**Physical Examinations.**—Nearly 4,000,000 officers and men were given a careful physical examination by the Medical Department before admission to the military service and approximately the same number were again examined before demobilization; careful records thereof protect the interests of both the individual and the Government. Valuable data as to the physical status of the nation were obtained from an analysis of these examinations.

**Personnel.**—On April 6 1917, the Medical Department personnel was not even sufficient for the peace-time needs of the small regular army. The increase is shown in the following table:—

April 6 1917	November 30 1918 (Approximate)
Medical Corps . . . . . 491	Medical Corps . . . . . 30,500
Medical Reserve Corps, on active duty . . . . . 342	Dental Corps . . . . . 4,600
Dental Corps . . . . . 86	Veterinary Corps . . . . . 2,000
Veterinary Corps . . . . . 62	Contract Surgeons . . . . . 940
Contract Surgeons . . . . . 181	Civilian employees . . . . . 10,700
Civilian employees . . . . . 450	Sanitary Corps . . . . . 2,900
	U.S.A. Amb. Service . . . . . 206
Nurse Corps . . . . . 233	
Reserve Nurse Corps on active duty . . . . . 170	Nurse Corps . . . . . 21,480
Enlisted Personnel . . . . . 6,900	Enlisted Personnel . . . . . 264,000

**Hospitals.**—When war was declared the army possessed four general and 113 small station hospitals with a total capacity of 6,666 beds. At the height of military activities there were in the United States 47 general hospitals, about 40 large base hospitals (ranging in size from 800 to 3,000 beds each) and a great number of smaller hospitals; the total capacity was over 130,000 patients. In the A.E.F. at the time of the Armistice, Nov. 11 1918, there were in operation 153 base, 66 camp and 12 convalescent hospitals with a bed capacity of 283,553. By Dec. 5 this capacity had increased to 296,865 and with buildings already leased, under construction or authorized, would in due course have reached 423,722, with crisis expansion to 541,000. (W. P. C.)

**ARRIAGA BRUN DA SILVEIRA E PEYRELONGUE, MANOEL JOSÉ D'** (1839-1917), Portuguese politician, was born at Horta, in the Azores, in 1839. He was educated at the university of Coimbra, where he took his degree in law in 1866. He became known as a strong Republican, and in 1882 was elected deputy for Funchal, in 1890 becoming deputy for Lisbon. His Republican principles caused him to be a figure of much importance

at the time of the revolution of 1909, and on Aug. 24 1911 he was elected first president of the Portuguese Republic (see PORTUGAL). He resigned office in 1915, and died March 5 1917.

**ARROL, SIR WILLIAM** (1839-1913), British engineer, was born at Houston, Renfrewshire, Feb. 13 1839. In his boyhood he was apprenticed to a smith at Paisley, and worked through several engineering shops until, in 1868, he was able to set up as a boiler-maker. In 1872 he took up construction in steel and started the Dalmarcock ironworks, becoming an expert in bridge-building. The Caledonian Railway bridge at Glasgow, the reconstructed Tay bridge (1882-7), Forth bridge (1882-9), the Tower bridge, London, and the Nile bridge at Cairo were amongst his principal achievements. He was knighted in 1890. He sat in the House of Commons for Ayrshire (S.) as a Unionist member from 1895-1906. He died at Ayr Feb. 20 1913.

See Sir Robert Purvis, *Sir William Arrol* (1913).

**ARTILLERY** (see 2.685).—Before the World War, the general military ideas of artillery procedure and purposes were somewhat the same in all countries.

It is proposed here to consider the lessons of the World War in the order in which they were learnt. As the war progressed, fresh problems presented themselves, fresh necessities arose, and artillery methods, equipment, and organization had to be modified to meet them.

The war on the western European front may be divided into four phases: a dash by the invader into the enemy's country; a long period of immobile warfare, both sides entrenched; and the breaking of the line, followed either by retreat and reconstruction or else by the full exploitation of victory.

The first, or mobile, phase of a modern war is of the greatest importance; it decides whether the campaign is to be fought in the defender's country or in the invader's. When one country attacks another, it is the object both of her statesman and her soldiers to make the initial dash as rapid and effective as possible; so as to finish the campaign in the first stage, and to avoid the long war of attrition which results when two nearly equal armies are entrenched. Similarly, the defender endeavours to crush the invading force at the outset, or to drive it back into its own territory. Therefore, in pre-war preparation, the requirements of trench warfare must be subordinated to those of mobile warfare.

In the World War, at least four-fifths of the main Western campaign was fought in the trenches; and the only seriously contested campaign in which the first phase was carried through to a finish was the invasion of Rumania by the Germans. Even in Allenby's brilliant Palestine campaign there was a long pause after the taking of Jerusalem. It seems highly probable that the longest, though not the most important, period of a future war will consist of trench warfare. Speculation as to the effect of new weapons, such as tanks, aircraft, and gas, in changing the nature of war, may be as misleading as regards the future as it has been in the past, and; at the least, it is necessary, at the present time, to provide for trench warfare as well as for mobile warfare in the training and equipment of an army.

## I. MOBILE WARFARE

**Mobility.**—The initial phase of a war requires a high degree of mobility. Once the invader has left his own railways behind, he must, at first, depend almost entirely on roads. He desires to advance at the rate of 50 miles a day, which is a very different matter from covering 20 m. an hour over short distances. The defender requires an equal degree of mobility to counter the attack. Motor transport for guns and infantry is the only means of attaining this marching pace. As regards the artillery, with which we are here concerned, the gradual disappearance of the civilian "van horse" will, in course of time, make it difficult to keep up horsed guns in peace time, and impossible in war. There is therefore a general agreement that the artillery must become motor artillery. It is obviously impossible to make such a change all at once; the question is, which natures and formations should be converted first. Before dealing with this point we may consider the types of artillery motor required.

The weight of artillery opinion is against the automobile gun-carriage, which is too large to dig in or conceal, and too vulnerable; moreover, the motor is useless when the gun is in action, and might better be employed elsewhere. Pulling a gun behind a tractor has many advantages, and is economical of transport, since the tractor carries the men and first supply of ammunition. The difficulty is that an ordinary Q.F. gun-carriage breaks up when drawn by a tractor at any pace faster than a walk. In March 1918, at the time of the German attack, the French brought up a large number of field guns drawn by lorries. These guns had to be fitted with rubber-tired wheels for the purpose. Again, in the autumn of 1918, the French (who were by then very short of horses) used field guns carried on lorries, with the gun-teams carried in motor-omnibuses converted into horse-floats. Only sufficient horses to bring the guns into action were transported in this way. By the end of the war the French had 266 tractor-drawn batteries of divisional artillery, and 306 batteries on lorries.

The French sometimes adopted a still bolder solution of the problem, namely, carrying the 7-ton caterpillar tractor on a special road lorry. Some authorities are disposed to think that this heroic method offers a better prospect of success than trying to produce a tractor that shall be able to cross country and also to travel fast on the road without damage to the surface. For a light caterpillar tractor, capable of pulling a field gun across country, may be made to weigh 50 cwt. or less, so that a large 4-ton lorry can carry both the tractor and a 30-cwt. field gun as far as the point where the gun has to leave the road. However, the method of carrying one motor on another seems so wasteful that it is regarded as a last resource.

The Italians have tried carrying the guns on lorries, with ramps to run them on and off, but find the system wasteful of transport; the gun takes up so much space on the lorry that there is no room to load it to its full capacity with men and ammunition. In 1921 they were experimenting with low-travelling platforms, of which one or possibly two are to be drawn by elastic couplings behind a fast road tractor; the platform, which carries a wheeled field gun, is on rubber-tired wheels and is supported on road springs so as to run smoothly at 12 m. an hour. These are for reserve "army" field artillery, and the guns are to be drawn into position by the horses, or cross-country tractors, of the divisional artillery which they replace.

There is one set of conditions under which the carrier has the advantage of the tractor, and that is in getting guns forward over the "crater-field" when this is very boggy. In the zone of contact of two hostile forces, when these are entrenched, the ground is pock-marked with shell craters, and in wet weather it may become a swamp into which any wheeled vehicle sinks, even if it is attempted to drag it behind a caterpillar. There are certain conditions of ground over which a caterpillar can carry a gun, though it cannot drag it. These must, however, be considered exceptional, and too rare to justify the adoption of carriers in place of tractors. Moreover, the sinking of the gun may be obviated to a great extent by using "girdles," which are linked plates surrounding the wheels. Girdles are also used on wheeled tractors for crossing soft ground.

A very important factor in the question of the motor transport of artillery is the necessity of using the agricultural motors of the country in time of war. The French are now endeavouring to produce an agricultural tractor, mobile on and off the road, which shall fulfil military requirements and shall also be used in very large numbers for agriculture. The introduction of a proportion of automobile gun-carriages, though spoken of by the French press, is a question which is still unsettled. The French guns up to the 6-in., and howitzers up to the 9.45 in. inclusive will be road-mobile, being divided into tractor loads, where possible not exceeding 5 tons net. All heavier natures will be on railway mountings.

In Italy, the intention is to have all the divisional artillery (which is to consist of field guns and field howitzers only) drawn by small agricultural tractors, road speed 5 m. an hour. These are not to be caterpillars but four-wheel-drive motors, and it is considered that the pattern adopted (Pavesi of Milan) will be sufficiently mobile across country. Girdles are carried for use on soft ground. The army field artillery will be drawn by fast road tractors as mentioned above. The corps artillery, consisting of 4-in. guns and 6-in. howitzers, will be drawn by wheeled road tractors of 50 and 55 H.P. These are also used for the component parts of heavy artillery loads up to the 12-in. howitzer inclusive. These also carry girdles for soft ground.

The question of artillery transport is more urgent in Italy than elsewhere, since the country produces no artillery draught-horses. Italy is the only country which has actually begun the conversion of horses to motor artillery; the United States and France, though they used motor artillery during the war, are still only preparing to introduce it as part of their permanent organization. The Italian "autobattenti" army regiment of 48 field guns referred to above is the only such unit in existence. The reason why wheeled tractors, not caterpillars, have been preferred is that owing to the nature of the cultivation there is no prospect of cross-country agricultural tractors of the caterpillar type being used on any large scale.

The United States are trying both tractors and automobile gun-carriages; apparently they do not favour platform carriers.

The order of conversion of the different horsed artillery formations to motor transport will probably, in all countries, be on

the following lines: (1) All transport which keeps to the road, including ammunition columns; (2) all guns and howitzers heavier than the divisional artillery; (3) army field artillery; (4) all first-line ammunition wagons; (5) guns and fighting battery wagons of the divisional artillery. It is, however, an open question whether army field artillery should not be converted to motor transport first of all, on account of the high importance of having a reserve of field artillery, able to travel long distances at a fast pace, available on the outbreak of war.

It need hardly be said that in future the artillery motors of the fighting formations will belong to the artillery and be driven by artillery drivers, not by men borrowed from the general transport corps of the army.

**Road-Mobile Super-Heavy Artillery.**—One of the first surprises of the war was the reduction of the strong fortresses in Belgium and northern France by the German super-heavy artillery. These fortresses were designed to resist 6-in. guns and 8-in. howitzers, and the Germans brought up 12-in. and even 16.5-in. (42 cm.) howitzers by road to attack them. The limitations of the transport of heavy loads by road vary in different countries. The British used 22-ton traction engines in the S. African War of 1899-1902, at the end of which they were sold out of the service as too heavy for English bridges. The bridges on the continental "national" roads are stronger than most English bridges, and, on some routes, are capable of taking a gross load of 30 tons on four wheels. The 42-cm. howitzer was divided into loads, the heaviest of which was about 20 tons gross. It was no doubt built with regard to the roads by which it would have to travel. A short (25-calibre) 9.2-in. gun or long 8-in. gun would make loads of the same weight. However, in France it has been decided, as mentioned above, not to transport super-heavy ordnance by road. These pieces are all to be on railway mountings. The reason for this is the greatly increased range which was demanded of howitzers during the war; thus the British 6-in. howitzer in use in 1914, which ranged 6,000 yd., was replaced by a howitzer of the same calibre ranging 11,600 yd., and a similar increase of range was required of all pieces which, before the war, were classed as siege artillery. It is therefore considered that it will always be possible to find or to build a position for heavy guns and howitzers on railway mountings within range of a fort or of any target which they may have to engage.

**Liaison.**—An early experience of the war was the breakdown of the method of coöperation of infantry and artillery which had been taught in peace time. The French were the great exponents of this method. It consisted of *liaison par le haut*, which means, for instance, that the divisional commander details a *groupe* of three batteries to support the attack of a brigade of infantry; and *liaison par le bas*, which means that the infantry brigade and artillery group commanders, and even their subordinates, the battalion and the battery commanders, keep up constant communication during the fight. Under battle conditions, *liaison par le bas* broke down at once. The British did rather better than the French, because they had five officers per battery as against three, and because they were trained in the use of the concealed artillery position, which necessitates distant communications. During sedentary warfare communication was perfect; every company in the front-line trench had a battery to support it, and the battery prided itself on putting over a storm of shrapnel within 10 seconds of receiving the call for assistance. But as soon as the troops left their trenches, in advance or retreat, direct communication between infantry and artillery units ceased altogether. Telephone lines were cut by the enemy's fire; visual signals were shot down, or, even if they succeeded in finding cover, the smoke and dust soon interrupted their view. Orderlies rarely succeeded in getting through, and the few that escaped being killed or wounded arrived too late for their messages to be of any use. Many devices were tried by the armies engaged; the German system of light signals was the least unsatisfactory. But the direct and intimate coöperation of infantry and artillery units was never realized.

**The Barrage.**—This breakdown of communications obliged the contending armies to adopt a simpler means of cooperation, and led to the general introduction of the "creeping barrage" (French *barrage roulant*, German *Feuerwalze*). Briefly, it is a screen of shells bursting on and close to the ground, which is moved forward across the country by short leaps according to a pre-determined time-table. It is "halted" on each successive objective for some 10 minutes before the infantry assaults it, in order to intensify the effect. It is then moved forward again to screen their further progress, and, when the last objective has been reached, it becomes a "standing" barrage to screen and protect the troops while they "consolidate" the ground which has been gained.

The infantry follow behind the barrage, keeping just clear of the zone of bursting shell. They are screened from aimed fire by the smoke and the dust thrown up, and the barrage is intended to destroy any opposition as it passes on. If it succeeds in doing this, communication between infantry units and the supporting artillery becomes superfluous. It has proved practically impossible to control or check the pace of the barrage when it has once started, although the Germans attempted to do so by light signals. This is on account of the difficulty of passing the information from the particular infantry unit which wants a modification of programme to the particular battery or batteries concerned with that part of the barrage, through a "chain of command." For at least one gun per 20 yd. of barrage front is used, and the batteries whose concentrated fire forms the barrage may themselves be widely dispersed.

Similar creeping barrages are used to screen retreating troops, though the problem is then more difficult, since the enemy dictates the pace of retirement. Such barrages are therefore made as simple as possible in plan and in execution. Other forms of barrage are used. "Flank" barrages are used to screen the flanks of troops, either halted or in motion. "Standing," as opposed to "creeping," barrages are used for many purposes, such as to prevent the enemy from reinforcing a portion of his line which is being attacked. A form of standing barrage often used for this purpose is the "box" barrage, consisting of one barrage parallel to the front attacked and two at right angles to it, forming three sides of a rectangle. A "preventive" barrage is put down over the enemy's lines when he is supposed to be about to attack. A "counter barrage" is one put down when the enemy is actually attacking, so managed as to take effect on his troops as they follow up their own barrage. In some instances a sham barrage, with no troops behind it, was used to divert attention from the real attack.

Important as the barrage is, it cannot be considered a satisfactory substitute for aimed fire; it is an expedient, which has to be resorted to when fire of precision cannot be carried out. Marshal Foch had occasion to warn the French artillery against trusting too much to it. In a circular issued in the summer of 1918, he writes:—

"The rolling barrage adopted by the Germans no longer meets the conception of the present war. The artillery cannot pretend to overwhelm the entire terrain of the attack with a rolling barrage, even if redoubled. Its object is not gained by unloading a brutal fire over a given zone and searching progressively at random with a fire directed straight to its front, without regard as to whether it is followed by the infantry. It is better to attack definite points and intensify the interdiction, the counter-battery, or the crushing fire on certain points, reserving a part of the field batteries for accompanying the infantry in intimate cooperation with it."

In other words, it is unsound to abandon at the outset all fire of precision on important targets, and every endeavour to work in cooperation with the infantry, and, instead, to attempt to mow down all opposition with a machine.

**The Barrage in Mobile Warfare.**—Although the creeping barrage is primarily used in the deliberate attack on an entrenched position, even in mobile warfare troops are frequently checked by an enemy holding an improvised position, and it may then be necessary to bring up all available artillery at once, and to form a creeping barrage to cover the attack. When an attack is led by tanks, it is necessary to have a barrage to conceal them, otherwise a great many are hit.

Wireless telegraphy may possibly be so developed as to become both directive and selective, so that a hundred stations may talk at once without mutual interference, or risk of being "jammed" by the enemy. Some progress in this direction has already been made. If this or other reliable means of sending and receiving messages becomes a practical fact, it will solve the problem of communication between infantry and artillery, and the crude method of barrage will fall into disuse.

**Guns of Accompaniment.**—As the creeping barrage advances it is intended to destroy all opposition. But it was found in practice that enemy detachments provided with good cover, such as machine-gun sections with overhead protection, got underground while the barrage was passing over them, and then reappeared, causing very heavy losses to the attacking troops. The French ascribe the majority of their losses in the last phase of the war to this cause. Now it would be extremely dangerous, even if it were possible, to bring the barrage back to "pound" such a danger spot. By the time this had been done, the advancing troops might very possibly have disposed of the machine-guns by bombing, and have resumed their advance, in which case they would come under their own barrage fire. It is manifestly impossible to get the fire of distant guns on to a machine-gun nest in time, though something might be done by an aeroplane dropping a light-ball on it to attract the attention of the guns. The result of the failure of artillery support in this matter has been a general outcry for guns of accompaniment; that is to say light guns, either pack, motor, or hand-drawn, capable of advancing with the infantry, and of dealing with machine-gun nests and strong points that have survived the barrage, and with tanks.

The matured German opinion is expressed in the following quotation from a document issued scarcely 10 weeks before the Armistice:—

"The guns of accompaniment must engage at short range the enemy with whom the infantry is fighting at close quarters. By reason of their proximity to the infantry they can be fired at the right moment, and on the right target, more easily than the artillery in rear. Also, being at close range, they can fire on objectives which cannot be observed from the rear."

A light 9-pounder, firing H.E. shell only, to an effective range of about 2,000 yd., is the type of weapon required. The British used their 3.7-in. mountain howitzer, firing a 20-lb. shell, when available; but the ammunition was considered too heavy, and troops who possessed captured German light trench mortars, firing a 14-lb. shell, found this a better weapon for the purpose. The latest type of gun is the U.S. "infantry howitzer," which is carried so far forward as possible by a small cross-country motor vehicle, and thence wheeled or carried by hand. It fires a 6-lb. shell for direct fire, and a 9-lb. shell for high-angle fire.

These guns are required at the rate of about one per 100 yd. of the front of the advance, or from 12 to 16 per division. The French have decided that a gun of accompaniment is to be introduced, and it is understood that it will be motor-drawn or motor-carried, but no further details are available. The Germans, in 1917 and 1918, used a variety of light guns styled "infantry guns" in addition to their infantry trench mortars, which were fitted for direct as well as for high-angle fire. But in the great 1918 battles their invariable practice was to detail one, two or more batteries of the divisional field artillery, fully horsed, and with their own ammunition carriages, to support the divisional infantry attack by direct accompaniment (sometimes reinforced). After trying other methods, they finally adopted the practice of allotting sections, or even single guns, to the battalions engaged. These single guns or sections followed up the leading lines of infantry, running up by hand when the horses could not get forward.<sup>1</sup>

<sup>1</sup> The relation of the artillery commander to the infantry commander, both being on the spot, was a difficult question which was never definitely solved. In practice, indication of task was as a rule the duty of the infantry commander, and choice of position and method that of the gunner. But the latter remained free to engage any favourable target without waiting for orders. (C. F. A.)

**Gun-Carrying Tanks** are here considered as gun-carriers. A war-time tank normally carried two short 6-pounder guns, one on each side, and 200 rounds of ammunition; it could carry another 100 rounds if required. If the tank were made larger, it could carry a 12-pounder or 18-pounder gun inside. When the gun is put outside, on the top, the machine ceases to be a tank and becomes an automobile gun-carriage or a caterpillar carrier; these have been discussed on pp. 248-49.

The volume of fire from a tank is not sufficient to constitute a decisive factor in the combat. Fire with shrapnel and time fuse from a moving tank would be a waste of ammunition, and the tank would not last long if it stood still. The small H.E. shell is nearly useless against men in the open, and the case-shot which the tank carries is effective only at very short range. The guns of a tank cannot be expected to engage infantry manning a trench parapet, and keep down their fire, except when the tank succeeds in getting astride of the trench and firing down it to right and left. Even then the effect is rather moral than material, since the infantry are protected by the traverses and indentations of the trench, which are specially designed to prevent enfilade. Practically, there are only two things that the guns of a tank can do, but these are both important. They can destroy an enemy tank, and they can put a H.E. shell into a machine-gun emplacement at short range, long before a message could be got through to a field gun a mile behind. For both these purposes the 6-pounder gun is sufficiently powerful, though it is possible that thickly armoured tanks may be introduced which will require a heavier weapon to pierce them. Quite apart from its gun-power, the tank supplements and sometimes replaces artillery fire by its power of crushing obstacles, notably barbed wire and iron palisades.

It remains to be considered whether the tank is a satisfactory substitute for the infantry gun of accompaniment. The advocates of tanks anticipate that in future an infantry attack will be carried out on the following lines:—In front of all is the creeping barrage, closely followed by the infantry and the light tanks ("cruisers") armed with machine-guns and possibly 6-pounders; behind these come 18-pounders or heavier pieces on armoured automobile carriages ("battleships"), and small fast caterpillars ("destroyers") carrying tank-stopping machine-guns. Just before the assault the "cruisers" dash forward in advance of the infantry, supported by the fire of the "battleships" and escorted by the "destroyers." The "battleships" also deal with machine-gun nests and strong points that have escaped the barrage. As the infantry continue their advance, the motor-drawn guns behind, which have been forming the barrage, advance by themselves to fresh positions behind the infantry, and carry the barrage forward.

Supposing an attack on these lines to be carried straight through, no infantry guns, capable of fighting on their own wheels, would be required. But it is objected that if the infantry attack were checked, as is inevitable at times, their only guns of accompaniment would be the large and conspicuous "battleships," which are very vulnerable when standing still. The same objection would apply in a retreat, which is a series of halts to check the enemy. It would appear, therefore, that the infantry gun must be separable from its motor, so that it can fight, and conceal itself, on its own wheels. Neither the "cruiser" nor the "battleship" tank satisfies this condition, but it may possibly be desirable to introduce a tank which shall carry a light gun to the fighting front, dismount it, hand it over to the infantry, and then advance on its own account, with its machine-guns, as a fighting tank. No tank of this kind has yet been tried, and moreover there is no present prospect of the large and expensive armoured "battleships" being provided in any army. Manufacture on the large scale would probably not begin till the outbreak of war. In the meantime, the infantry gun of accompaniment will have to be developed as an infantry weapon, independently of the "land fleet." Whether it should be motor-drawn, motor-carried, mule-carried or man-handled is still an open question. Many officers are in favour of a gun drawn by a small tractor, to take it as far forward as possible;

the gun to be light enough to be man-handled when the tractor fails. The American infantry howitzer referred to above realises this idea, except that it is carried instead of being drawn.

**Artillery Fire on Tanks.**—The best means of stopping tanks is still an open question. It would at first seem a simple matter to make direct hits on them, but in practice the enemy's barrage and bombardment interpose a screen of bursting shells behind which the tanks can approach unseen. Moreover, it is not easy to find a position affording a good view, from which the gunners can lay over the open sights, within 2,000 yd. of the front line. Indirect laying is too slow for moving objects. When preparing to meet the German advance of March 1918, the British plan was to hide a number of field guns in or close to the front line, which were to keep silent till tanks appeared, and then fire on them. These guns were never heard of again; they were all destroyed by the intensive bombardment which preceded the attack. In some cases, land mines were buried under the barbed wire entanglements to prevent the tanks from rolling them out; but these mines hardly survived the bombardment. They might be useful, however, if the enemy attempted a surprise attack with tanks without a preliminary bombardment. The best means of resisting a tank attack on an entrenched position would appear to be the provision of numerous small anti-tank guns in the trench area, as described below.

In mobile warfare the conditions are somewhat different; in the autumn of 1918, when the British alone used 2,000 tanks, many of these were destroyed by the German rear-guard batteries, and by concealed guns left behind for the purpose. The Germans used heavy single-loading "anti-tank rifles," pending the introduction of large calibre "anti-tank machine-guns," and it is stated that a tank-stopping rifle grenade, fired from the muzzle of an infantry rifle, has lately been produced. It would seem, however, that in open warfare the most formidable opponent of the tank is the enemy tank, and it is probable that a special type of light fast tank—a "tank destroyer"—armed with one gun amidships, or even with a heavy machine-gun only, will be introduced.

## II. TRENCH WARFARE

The lessons of the first phase of the war had been the necessity for a high degree of mobility, the breakdown of direct *Nazi* between infantry and artillery, and the weakness of permanent fortifications of old-fashioned type when attacked by modern guns. When the armies settled down to "sedentary" trench warfare, a fresh set of problems presented themselves.

At first, the trench system, however multiplied in detail, was simple and continuous in the ensemble; in 1915 a system of ten consisted of three lines or chains of trenches half a mile apart and connected by communication trenches. But, in the latter part of the war, different principles were followed, and a modern trench system is not a single strongly garrisoned line, in which the troops would offer an easy target to artillery, but a fortified zone two to three miles in depth. The front nearest to the enemy is not a continuous parapet; it is dotted with inter-supporting points of resistance, varying from a shell-crater holding three men to an armoured "pill-box" or a fortified "strong point" held by a platoon with machine-guns. The actual front trench may be a mile behind the front of the system, and in any case is not visible to the enemy. It is dug on a reverse slope when possible, as a field of fire of 200 yd. is quite enough for modern rapid-firing rifles and machine-guns. Even the front trench is often not continuous, but consists of short lengths arranged so that each can be enfiladed by guns, or more usually machine-guns, in rear. It is a chain of defences, rather than a continuous barrier. Behind the front trench is a network of fire trenches, strong points, and communication trenches from one to two miles in depth; this is styled the "battle zone." Behind this is the second-line trench, which forms the front of the "reserve zone." Still further to the rear there may be second and third trench systems and reserve lines. The ground in front of the battle zone is the outpost zone, and is not intended to offer serious resistance. Its function is to screen the

battle zone, and to delay an attack long enough to allow the battle zone to be manned.

The field artillery have three sets of positions, known as forward, main, and reserve. The forward positions are in the battle zone, and the guns posted there are intended to protect the outpost zone, and to support minor attacks made from this zone (see p. 253, *Warfare between Front Trenches*). The main positions are 3,000 to 4,000 yd. behind the front trench, that is, in the reserve zone, some 1,000 yd. behind the second-line trench; the guns posted in the main positions barrage the front trench and support the infantry in the battle zone. The reserve positions are 3,000 to 4,000 yd. behind the second-line trench, and the guns, when they occupy them, barrage the second-line trench and support the infantry in the reserve zone.

Normally about one-third of the divisional field artillery are in the forward positions and two-thirds in the main positions. The reserve positions are ready for occupation and supplied with ammunition.<sup>1</sup>

The medium and heavy artillery are behind the field artillery, and the wagon lines are out of field-gun range, that is, at least 5 m. from the enemy's field artillery positions. Additional artillery positions are prepared, so far as the supply of labour permits, for reinforcing units, which are put in when it is intended to attack, or when an enemy attack is threatened. All guns normally belonging to the front are in emplacements provided with overhead cover, and carefully camouflaged against the camera. All fire trenches and entrenched posts (called "strong points") are protected by entanglements of barbed wire. Artillery observing posts ("O.P.'s") from which the fire of the batteries is directed, are disposed wherever they can be concealed, and the whole system is connected up by an elaborate network of telephone wires, the main lines being (in British practice) deeply buried.

The arc of fire required of each battery has to be considered when siting and entrenching it. The following is a typical arrangement, subject to considerable local variation. It applies to a division of three infantry brigades of four battalions, three field-gun brigades of four batteries, and one field-howitzer brigade of four batteries. Each infantry brigade holds one unit of front, about 1,000 yd., and is supported by one field-gun brigade. Of the four batteries of this brigade, three cover their own unit of front and can cover one more unit on each side, making 3,000 yd. of front; the fourth battery is a "swinger," and covers two units on each side of its own unit, making 5,000 yd. of front. All the field-howitzer batteries are swingers. This arrangement enables the division to turn 13 field batteries on to any point on its own front, and to turn 6 field batteries on to the front of either of the neighbouring divisions when called upon. The medium, heavy, and super-heavy guns and howitzers are all sited, when possible, so as to engage any target within their range.

Under these conditions, as soon as trench warfare began, artillery fire became a matter of very careful preparation and rapid execution. A battery was liable to be called on suddenly to fire on any one of a hundred different targets, visible from an O.P. or not. The first essential was to get every gun to shoot to map range. In open warfare, artillery firing at visible targets neglect the "error of the day" due to variations of temperature, barometric pressure, and wind, since this is corrected by direct observation of fire. In the trenches this error became of great importance; it might, and did, make the difference between hitting the enemy or our own infantry. The daily "Meteor" telegram from the meteorological section of the army corps was supplemented by reference to the thermometer and wind-gauge whenever a battery opened fire. Worn guns were carefully "calibrated" so that their error could be allowed for; this was

<sup>1</sup> The British, who used 6-gun batteries, used to keep two guns of a battery forward and four in the main position; with 4-gun batteries it is not usually advisable to split them up. The Germans used to keep the whole of their field guns in the main and reserve positions, and these were further back than those described above; guns were sent up to the advanced positions for special tasks only, and were withdrawn as soon as these had been completed.

done at special ranges behind the front, or, when this could not be done, by firing at known points in the enemy's lines. The next matter was to obtain an accurate map, with the positions of the batteries and their targets marked on it, so as to enable the exact map range to be measured.<sup>2</sup> The result of this work was a great improvement in shooting, and consequent economy of ammunition. Unfortunately the varieties of powder supplied caused a further complication. It proved impossible to distribute the ammunition so that each brigade had always one particular nature or brand of powder, except on special occasions, when preparations were made for a great attack. It was therefore customary, in trench warfare, to "register" all prospective targets, or at least points near them.<sup>3</sup>

*Howitzers.*—The necessity for searching deep trenches and penetrating overhead cover gave rise to a demand for more howitzers. The field gun, firing shrapnel, was invaluable when the enemy moved about their trenches, or showed themselves over their parapets; at other times shrapnel was of little use, except for barrage. The field gun H.E. shell was too small to penetrate parapets, and the field-howitzer shell did not penetrate well-built dugouts. All the belligerents found that the most useful weapon for bombardment was the 6-in. (15 or 15.5 cm.) howitzer, throwing a shell of 100 pounds. The Germans in particular regarded this as their most important weapon for trench warfare. In 1914 the British army had only a few old-pattern 6-in. siege howitzers, but from 1915 they had a 6-in. Q.F. howitzer ranging 10,000 yd., which range was afterwards increased to 11,600 yd. by the issue of stream-line shell. By the end of the war the British had 6,437 howitzers in France alone; 3,633 6-in. howitzers had been issued, and 1,438 were in the line on Armistice day, which shows the rate at which they were worn out. They fired over 22,000,000 rounds.

Similarly in 1914 the French had only 300 howitzers of 155 mm., of which 104 were mobile. In 1918 they had 6,000 of this and larger calibres.

The heavy and super-heavy howitzers, 8-in. (20 cm.), 9.2 or 9.4-in. (24 cm.) and higher calibres were used for work too heavy for the 6-in.

For all calibres over 6-in., howitzers soon began to supersede guns, though a few flat-trajectory heavy guns were used. The reason for this was a question of supply. A howitzer firing at 45° gets its shell to the target with a much smaller powder charge than a high-velocity gun, and consequently lasts perhaps 10 times as long before it has to be retubed.

*Increased Range.*—The precision with which "map fire" could be carried out by the methods described above led to headquarters, wagon lines, ammunition "dumps," and installations behind the lines being shifted to greater distances from the front. This created a demand for increased range. When the Germans initiated the system of covering the front with a zone of "pill-boxes" and small posts, and withdrawing the front trench (or its equivalent chain of short trenches) a mile behind the front of the defended zone, the ranges were still further increased. Even before this, the Germans had lengthened their field gun and brought out a stream-line shell which increased its range from 6,000 yd. to 11,700 yd.; their old field howitzer ranged 7,600 yd., their 1916 pattern 10,500 yd., and similarly with the 6-in. howitzer and larger calibres. Other nations did the same; the French altered the trail of their 75-mm. field gun so as to get more elevation and increase the range to 11,000 yd. with stream-line shell, and introduced their short 19-cm. gun, converted

<sup>2</sup> This resurvey often showed local landmarks to be 100 or 200 yd. from their positions as marked on the original maps.

<sup>3</sup> Registration consisted of firing a series and noting the result, corrected to standard "Meteor" conditions. These series were observed from O.P.'s when possible, otherwise by aeroplanes or sound-ranging. Thus when an enemy working party was reported by an aeroplane in Trench 56, a battery commander got the order "Target 56 stop 25 shrapnel 25 HE Fire." He looked up 56 in his registration book, corrected the recorded elevation, direction, and fuzer for "Meteor," and powder in use, gave his orders, and his guns fired the 50 rounds in half a minute. The aeroplane observed the result, which was entered in the registration book for future reference.

to an 8-in. howitzer. Its guns designed since the war the increase of range is very marked; thus the United States require 15,000 yd. of range for their new field gun; the latest pattern of British 18-pounder issued during the war ranged 10,800 yd., and the forthcoming pattern will probably range as far as the U.S. gun.

**Hundred-Mile Guns.**—This general increase of range culminated in the German gun or rather guns (colloquially called "Big Berthas") which shelled Paris from a distance of 76 miles.<sup>1</sup> As early as 1915 the Germans shelled Dunkirk from a point 25 m. distant with a 14-in. naval gun, and they proposed, if they succeeded in driving the Allies back from Calais, to use 110-mile guns which should command the whole of the British coast from Yarmouth to Southampton, and the whole of the London district. Such guns are not specially difficult to make, and both the British and the French artillery authorities had worked out the design of 100-mile guns some years before the war. In principle they depend on firing a shell upwards so as to clear the dense layer of air lying next to the earth, and to attain a height of some 25 m. where the air is so rarefied as to oppose practically no resistance to the flight of the shell. Seven of these guns were used against Paris in 1918, and at the end of the war the Germans had six more building; the British, French, and Italian Governments had each at least one of these guns building, but it is understood that none of these were completed. Owing to the high powder-pressure employed, and consequent high temperature in the bore, the life of the German gun was only about 50 rounds, after which they had to be rebored. For this reason the 100-mile gun marks about the limit of practical possibility with propellants now in use. But, if it were considered advisable, it would be possible to make a special powder giving lower temperatures than the gun-cotton and nitro-glycerine powders now in use, and so increase the life of these guns.

**Flashless Powder.**—During "sedentary" warfare, any gun which fired at night within direct view of the enemy was liable to be marked down by the "flash-spotting" section opposite to it, who got cross bearings to it, after which it was soon shelled out. It was therefore necessary to introduce flashless powder, or else to add a portion of special chemical composition to the ordinary charge for all guns which could not be hidden behind woods or hills. The United States have specified that it is to be used in their new field gun.

**Ranging by Aeroplane.**—Apart from the work done by aircraft in locating targets by direct observation or by photography, they were used during trench warfare for ranging on targets which could not be observed from the ground. The aeroplane was from the first fitted with a wireless sending set; but it was only towards the end of the war that practical forms of receiving apparatus were evolved, and, generally speaking, messages to the aeroplane had to be sent by code signals, which were strips of white cloth laid out on the ground near the battery. Only simple signals such as "Ready to Fire" could be used; it was therefore necessary to arrange the details as to the target to be observed beforehand. Ranging was carried out deliberately, the aeroplane sending down the result of each shot. Only one such series could be fired at a time on an army corps front, as, with the instruments then in use, if two aeroplanes had been sending wireless at the same moment they would have interfered with each other. Until the means of wireless communication are improved, aeroplane ranging will remain too slow and elaborate a method for field artillery in mobile warfare, though it may be applied to heavy artillery.

**Sound-Ranging.**—This is described under RANGEFINDERS AND POSITION FINDERS. It consists in measuring the intervals of time at which the sound of an enemy gun successively reaches three or more stations, and, from the differences, calculating the position of the gun. It also enables the point at which one's own shell bursts to be located. The installation of these stations

takes about a day, and in certain conditions the method cannot be depended on or indeed used at all. In mobile warfare, sound-ranging may possibly be used to locate the enemy's heavy guns. **Warfare between Front Trenches.**—Simultaneously with the long-distance shooting at targets behind the fronts, constant fighting took place between the front trenches, which, early in the war, were in some places only 50 yd. apart. Even when the front trenches were shifted back behind screens of defensive positions, constant guerrilla warfare continued to be waged between the detachments opposite each other. The need for trench artillery was soon felt, and was supplied by a new class of weapon. The original trench mortars had only a very short range, and, as they had therefore to be kept close up to the front trench, the loss of life among the detachments was heavy. Later, longer-rang- ing trench mortars were introduced, which could be posted relatively far back, and were available for firing on our own front trench if the enemy broke into it.

Trench ordnance on wheeled mounts was used to some extent as accompanying artillery, especially the later pattern of the German light trench mortar, which was fitted for direct as well as for high-angle fire. But the excessive weight of the ammunition-rendered trench mortars unsuitable as substitutes for guns of accompanying.

**Wire-Cutting.**—Very early in the war it became necessary to find a means of destroying, or at least cutting lanes in the strong barbed wire entanglements which covered the whole front. At the period of the autumn battles of 1915, this was done on the British front by the shrapnel fire of field guns. This was effective for wire-cutting only up to about 1,300 yd.; within that range it was found that lanes could be cut through a belt of wire 8 yd. deep with an expenditure not exceeding 10 rounds per yd. of front. Later on, thick steel barbed wire came into use, which could not be cut by shrapnel bullets; moreover, the process of wire-cutting with shrapnel required precise and deliberate shooting, and had usually to be carried out on the day before the attack, thus forfeiting the advantage of surprise. Howitzer H.E. shell with ordinary fuzes proved useless, as they made craters into which the network of wire fell back, making a worse obstacle than before. In 1916 medium trench mortar shell with instantaneous fuse came into use; these shell made a crater not more than 6 in. deep, and blew away the wire from a circle about 5 yd. in diameter. But trench mortar ranges are very limited and it was not till the instantaneous fuse was adapted to H.E. shell for field guns and field howitzers that the range at which wire could be cut was increased to 4,000 yards. The French used the 75-mm. field gun, while the British mostly used the 4.5-in. field howitzer. As an alternative to the instantaneous fuse, a percussion fuse giving a slight delay action was used with H.E. shell for wire-cutting, the object being to burst the shell on the upward branch of its trajectory after impact, within a yard or so of the ground. Some success was attained with this method when the ground was hard and the angle of impact small, so that the shell did not tend to bury itself. Wire-cutting with H.E. shell is a much quicker method than with carefully adjusted shrapnel bursts, provided that a sufficient volume of fire is obtainable (see section EFFECT *supra*).

**Counter-Battery** work is the attack of artillery by artillery with the object of destroying the material and inflicting disabling casualties, or at least of neutralizing enemy fire for a certain time. In spite of the results achieved in locating enemy guns by aircraft, flash-spotting, and sound-ranging, counter-battery work throughout the war generally failed to destroy them and their detachments, or even to silence them permanently. However, when a battery was located it was usually possible to neutralize it, that is, to stop or much reduce its fire, so long as fire upon it could be kept up.

If a battery exposed itself in the open within range of artillery in position it was destroyed in a few minutes. Therefore batteries used concealed and camouflaged positions with overhead cover proof against field artillery. If such a position was located the battery was soon shelled out by the 6-in. and heavier howitzers, but it was rarely possible to destroy the guns without an

<sup>1</sup> The bombardment of Paris was spread over 140 days; firing took place on 44 days only. 183 8-in. shell fell in Paris, and 120 in the suburbs. The material effect was slight (256 people killed in 43 months) and the moral effect, after the first day, inconsiderable.



andue expenditure of ammunition. The usual result was that the gunners retired a few hundred yards (if they had no deep dugouts) till the shelling was over, and then came back to their guns. If they were shelled again they shifted their guns to another position. The ground in front of Vimy Ridge was a mass of positions from which batteries had been shelled out, and it was reckoned that one position in four was occupied. The British and the French used to repair abandoned positions to encourage the enemy to go on shelling them. Flashes were fired from dummy positions for the same purpose. "Silent" positions, from which the guns were not allowed to open fire till active operations began, were rarely located.

The Germans were fairly successful in neutralizing batteries with gas shell; concealed artillery positions, being usually in hollows or woods, are specially vulnerable to gas attack. If such a position be thoroughly drenched with persistent gas it becomes untenable, since men cannot work in gas-trunks for a prolonged period. In future, flashless powder will make it still more difficult to locate concealed artillery positions.

III. THE BREAK-THROUGH

During the three years 1915, 1916 and 1917 numerous attempts were made to break through the opposing line, the most notable being the German attack on Verdun. All these attempts failed; the less unsuccessful of them resulted merely in the capture of an unimportant strip of ground at a heavy cost. A discussion of the reasons for these failures would be beyond the limits of this article. From an artillery point of view it is more important to consider the method of attack which was finally evolved. The two leading principles are the following—

(a) *Surprise*.—This implies the rapid and perfectly timed concentration of artillery and infantry units in the area of the attack, so that they arrive just when they are wanted. If, as is probable, the result of the attack is that the enemy's line is not broken, but is only bent back, successive surprise attacks are made by shifting the weight of the attack quickly to other points which may be 50 or 100 m. distant, so as to form salients in the enemy's line, which are then "pinched out" by attacking them from both flanks. This, at least, is the obvious course; and, because it is so, it may not be the best one. In some cases a commander may decide that he has a better prospect of surprising the enemy by renewing his attack on the original point. Success depends principally on an organization which enables guns and men in large numbers to be placed in readiness for action in any selected area of attack either without the enemy's knowledge, or so quickly that he has no time for counter-preparation.

(b) *Wide Front*.—It is useless to make a narrow gap in the enemy's line, commanded by his guns from both sides. It must, roughly, be wide enough to allow for 10 m. of shelled ground on each side, and a 20 m. passage down the middle; that is, about 40 miles. The Germans in March 1918 attacked on a 50 m. front.

*Concentration of Artillery*.—The first step is to prepare for the concentration on the front of attack of a sufficient number

of guns. Normally the fire is held by about one gun to 30 yd. including field, medium and heavy. For an attack, this number must be at least trebled.

The Germans, in their great attack of March 1918 on the 50 m. front from Monchy to La Fere, had the following, counting normal establishments only—

- 1 field gun per 19 yd. of front
- 1 field howitzer per 57 yd. of front
- 1 medium howitzer per 128 yd. of front
- 1 heavy gun per 128 yd. of front
- 1 heavy howitzer per 256 yd. of front
- 1 superheavy howitzer per 512 yd. of front.

This alone amounts to one gun per 11 yd. of front; but in addition to this the four-gun field batteries were reinforced, as far as possible, by adding two guns from reserve. The extra guns were not horsed and the gunners were provided from personnel on the spot. There were also a certain number of miscellaneous guns and a very liberal equipment of trench ordnance. Altogether it may be estimated that the Germans, in this attack, had one gun per 9 yd. of the whole front attacked; but since the attack was pushed home only on alternate sections of this front the concentration of gun-fire on the real fronts of attack was much heavier than these figures imply, as explained below.

In the still more highly developed artillery attack of May 27 1918 on the Chemin des Dames the strength (according to Col. Bruchmüller, who was responsible for the arrangement) was—

- 1 field gun per 26 yd. of front, (not including about 30 batteries told off as accompanying artillery),
- 1 field howitzer per 47 yd. of front,
- 1 medium howitzer per 99 yd. of front,
- 1 heavy howitzer per 156 yd. of front,
- 1 medium or heavy gun per 200 yd. of front,
- 1 superheavy gun or howitzer per 1,126 yd. of front, or
- 1 field piece per 17 yd. and
- 1 medium or heavy or superheavy piece per 49 yd.

In the aggregate 1 piece per 12 yd. irrespective altogether of accompanying artillery; additional guns, and trench mortars.

In the battle of July 15 1918—the last German offensive—the trench-mortar strength was approximately one per 30 yd. for a considerable frontage, and locally as much as one per 10 or 12 yd.

*Positions for Artillery*.—Assuming that, for an attack, the artillery of a front, normally one gun per 30 yd., has to be increased to one gun per 10 yd., positions have to be prepared for the reinforcing guns. A certain number of spare positions with gun emplacements protected by overhead cover will already exist as part of the equipment of the front, but it is rarely possible to provide labour on such a scale that a defensive front is always kept ready to be used as an attacking front.

If it be possible to bring up the whole of the reinforcing guns during the last night before the attack the preparation will consist principally of marking out gun positions and roads to them, and laying telephone cables to them and to the observing positions. But even with motor equipment the concentration of the whole movement of the troops into one night imposes such a strain upon the transport that it will usually be necessary to spread the movement over three nights, and in this case efficient camouflage must be provided for the guns which arrive before the last night.

They were intended only to take part in the bombardment and not in the advance which followed.

The following table, from the *Revue d'Artillerie* of May 1921, shows the densities of artillery strength in certain French battles of 1915-7—

Yards of front per gun.

	1 field gun per	1 medium or heavy gun per	1 medium or heavy howitzer* per	1 medium or heavy gun or howitzer per	1 super-heavy piece per
Champagne, Sept. 25 1915	36 yd.	66 yd.	133 yd.	44 yd.	—
Somme, July 1 1916	36 "	30 "	68 "	29 "	121 yd.
Aisne, April 16 1917	22 "	48 "	99 "	26 "	253 "
Verdun (Mort-Homme battle) Aug. 20 1917	20 "	—	—	—	—
Malmaison, Oct. 23 1917	18 "	—	—	—	—

\* The French had no field howitzers.

The French "Offensive Instructions" of Oct. 31 1917 lay down a scale for the first-class offensive battle of about

- 1 field gun per 15 yd.
- 1 medium or heavy piece for demolitions per 30 yd.
- " counter-battery per 35 yd.

Superheavy pieces approximately at 1 per 170 yd. (plus 1 piece of trench ordnance per 30 yd., except in parts of the front reserved for tank action).

**Registration.**—The reinforcing guns must be able to open fire at zero hour. Usually the batteries belonging to the front register their targets for them beforehand, the registration being spread over several days so as not to attract special notice. But calibration, study of atmospheric influences, and surveying<sup>1</sup> have latterly been so thoroughly applied that it may be possible, in future, to rely upon opening effective fire by reap without ranging. This again requires thorough preparation, which is possible when an attack is planned beforehand. So far as can be foreseen, there is no prospect of dispensing with ranging when the troops are on the move.

**Conduct of the Attack. Bombardment.**—In the great trench battles of 1916 and 1917 it was customary to begin with a bombardment of the enemy lines lasting a week or even more. This was fatal to surprise action, and in 1918 the preparation consisted of some six hours or less of "intense" bombardment, every gun firing at its highest rate. The use of tanks may in future enable this bombardment to be shortened, as will be seen. The Germans pressed their great attack, of March 1918, only on alternate sectors (of about 3,000 yd.) of the British line, trusting to envelop the intermediate sectors. They were thus enabled to concentrate nearly the whole of their guns on half the total frontage, so that they had roughly one gun firing on every 5 yd. of the front actually attacked.

A reasonable estimate of the ammunition required for a six hours' intense bombardment, per mile of front seriously attacked is 50,000 rounds field gun ammunition, 10,000 field howitzer, 5,000 6-in. howitzer, 3,000 6-in. gun, 500 heavy howitzer, and 200 rounds superheavy howitzer. If the attack passes forward without a check for three days from the start, then at least 50% more will be required on the second day, and the same on the third day if the enemy is reinforced; at any rate it would be unwise to begin an attack without double the above amount in hand. If the attack is seriously checked the intensive bombardment will have to be repeated and a fresh start made. These figures give a fair idea of the scale on which guns and ammunition are used in modern warfare.

The reason for this vast expenditure of ammunition is that the bombardment is not confined to the front of the position attacked—the front zone, as explained above, is a thinly held system of outposts—it is directed mainly on the real defensive zones and centres in rear. Targets such as railway stations, bridges, and road junctions as much as 10 m. behind the front have to be bombarded by the long-range guns and howitzers.

**Influence of Tank Action on Bombardment.**—In the autumn of 1918 the tanks achieved such success in breaking through defences which had not previously been bombarded that it is considered that in some cases, provided that the ground is favourable for tank action, it may be possible to shorten the preliminary six-hours' bombardment to half-an-hour, or even to dispense with it altogether, and to trust to the creeping barrage to protect the advancing infantry and tanks (British Field Service Regulations, 1920, Part II., para. 118 (6)). When this method is employed all guns other than those firing the creeping barrage will concentrate on important points behind the enemy's front simultaneously with the launching of the attack.

This is a new method of procedure, in which our present experience is not sufficient to enable us to forecast the best course of action with any confidence. The regulation quoted above is cautiously worded, and does not imply that the use of tanks will render bombardment unnecessary. Even if the tanks are expected to succeed in rushing the first and second zones of the enemy's defences, they will certainly experience increased resistance as they penetrate deeper into the position. In future warfare tanks will not be the only motor vehicles on the battlefield. The mobility of the defender's motor guns and motor infantry, both on and off the road, will enable him to bring up reinforcements far more quickly than was the case in 1918. Although the attack may be launched without any previous bom-

<sup>1</sup>The position of one gun in each battery (or other unit) is fixed exactly by staves, and marked both on the map and on the ground before the guns arrive.

bardment, it will still be necessary to deliver a heavy fire on targets behind the enemy's front as soon as the attack is disclosed. It will not be enough to bombard railway stations and road junctions, if the defender's motor troops are independent of railways and roads. Therefore this fire will presumably be not so much a bombardment of fixed points as fire for effect, directed by aeroplane observation, upon the defender's reinforcements.

So far as can be judged the amount of ammunition required for an attack will be increased rather than diminished, in view of the scattered targets presented by motor troops.

**The Infantry Attack.**—As soon as the "intense" bombardment has done its work on the outpost zone and the first line the infantry advances, screened by a creeping barrage, preceded by tanks, and closely followed by guns of accompaniment. The bombardment is "lifted" from the first line to reinforce that on the second line; as soon as the infantry have taken the first line fresh waves of men pour through them to attack the second line. When the second line is taken the field artillery of the attack pushes forward by echelons to positions in or near the first line. Later on the medium and heavy artillery push forward.

It is not to be expected that the infantry will be able to advance on a continuous front. After the thinly held outpost system has been rushed progress is by "infiltration." Wherever a weak point is found the infantry pour through it, and the advancing streams of men, led by the local reserves, spread out to right and left and envelop the defensive points that still hold out. Tanks are here invaluable in leading the streams of riflemen, in "rolling over" barriers of barbed wire, and in rushing the centres of defence. It is the involved and complicated nature of this warfare which prevents the main body of the artillery in rear from supporting the infantry in the series of local combats which characterize the advance through the trench system, and which renders it necessary to provide the infantry with guns of accompaniment.

The process of infiltration outlined above is apt to produce irregular salients in the advancing line, which the artillery in rear find it difficult to protect by barrage, and which are therefore the more exposed to counter-attack. On this account it was the practice, at one time, to limit the objective—that is, to fix a line beyond which the troops were not to advance, so that when this line was gained they should present a continuous front, protected by artillery fire, from which a further advance could be made. This system led to a great waste of opportunity. It may still have to be adopted on occasion; but the modern tendency is to gain every possible foot of ground, and to provide reserves on a scale sufficient to "feed" the salients so that they can spread out laterally and "pinch out" the ground between them which is still held by the enemy. That is, every salient must become an offensive, not a defensive, feature. Without artillery support these offensive tactics would hardly succeed, against the defender's "strong points," which are not merely fire-trenches facing the front, but miniature forts prepared for all-round fire. It is necessary, therefore, that in addition to the guns of accompaniment part of the artillery in rear should press forward boldly, so as to keep in touch with the infantry and be able with the assistance of aeroplanes or of their own reconnoitring patrols to direct a heavy fire on any defensive work which still holds out.

The action of the artillery in the attack may be summed up as follows: the bombardment weakens the defence and the barrage protects the attack. The guns of accompaniment support the attack so long as the enemy continues to retire, offering only slight resistance intended to weaken the attack. When resistance becomes serious the divisional field artillery must be in position and in communication with the infantry, so that

<sup>1</sup>The word "line" is used in this description because no other accepted military term is available. In reality modern defensive systems consist of chains of detached works or trenches, supporting each other by their fire. The only continuous feature which marks a defensive zone is the belt of barbed wire entanglement, and this itself is irregularly traced.

they can support it in local combats. If the resistance becomes obstinate and beyond the power of infantry and field guns to overcome, the bombardment by the heavy artillery must be renewed.

These tactics are repeated as each successive line, or defensive zone, is encountered. The process can be repeated indefinitely so long as the supply of men, guns, and ammunition can be kept up, provided that it is possible to convey them to the fighting line. The latter has proved a very serious difficulty in the past, and has perhaps been more instrumental than any other cause in bringing great attacks to a standstill. It must be overcome by the work of the engineers in repairing roads and railways, and by the provision of improved cross-country vehicles.

*Artillery in Defence.*—Whether defence in the hitherto accepted sense is or is not the form of resistance best suited to modern conditions is a question which lies outside the scope of this article. For the present purpose it is assumed that the ground occupied is to be defended in the literal and tactical sense.

In the ordinary defence of a position the method of meeting an attack varies according to the degree of certainty with which the enemy's intentions have been anticipated, and the amount of preparation which it has been possible to make.

If the defender is fully prepared for the attack, and has massed his artillery to meet it, then he can reply to the initial "intense" bombardment with a similar bombardment, which will certainly render the attack ineffective.

If he knows when the attack is to be launched, but has not been able to reinforce his artillery, he can still put down a preventive barrage, just before "zero" hour, on the enemy's lines. This will weaken the attack, and may delay it.

Even if the defender has had no warning, and is unable to oppose gun for gun to the attack, the mobility of motor artillery should, in future, enable him to reinforce his artillery (provided he has guns available elsewhere) within two days at most. But the enemy will probably provide against this by making a holding attack on a very wide front, or on several fronts. The defender will be uncertain as to which of these is the real attack, and will be afraid to take any guns out of the line. He must then depend upon his general reserve for the artillery reinforcements which he requires.

We will consider the case of a section of an entrenched front, held with the normal proportion of artillery (one gun to 30 yd.), attacked by surprise by a concentrated force (one gun to 10 yd.). It is clear that the attacking infantry must come out into the open when they advance, and that they are then exposed to artillery fire. Putting down a shrapnel barrage at 10 seconds' notice on the enemy's front line, and bringing it back over one's own lines when necessary, is of course part of the regular routine of trench warfare. But the attacker counts on destroying or neutralizing the guns of the defence by his bombardment and counter-battery fire, and he is likely to succeed to a great extent as regards batteries which have previously disclosed their positions by firing. It is therefore necessary to have "silent" batteries in the line, that is to say, batteries which, ordinarily, are never allowed to fire except on occasions when visibility is bad, and then only under precautions against sound-ranging. The normal expenditure on a divisional front may be 1,000 rounds a day, or less on quiet fronts, and this allowance can be fired by a small number of batteries, so that there is no difficulty, other than the administrative one, in keeping half the guns of a front in silent positions in reserve to repel an attack.

Another necessary precaution is the provision of deeply buried telephone cables, proof against bombardment by heavy artillery; and these must be laid not only to the ordinary gun and observing positions, but also to the positions in rear to which the artillery may have to retire.

As soon as the attacker begins his "intense" bombardment the guns of the defence reply with a similar bombardment, necessarily on a scale corresponding to their smaller number.

"Silent" batteries take part in this, since the smoke of the bombardment will conceal their positions. When the infantry attack is launched, then, assuming that the defender has still a fair number of batteries effective, as soon as the call is made upon them the field guns and trench mortars of the defence put down a heavy barrage on the enemy's front-line and communication trenches. Medium guns and field howitzers barrage probable assembly points, while medium and heavy howitzers bombard the attacker's gun positions, so far as these have previously been disclosed. Since the defence has been weakened by the bombardment it is probable that the attacker will capture the forward zone. It takes one gun per 20 yd. to make a heavy barrage; the defender starts with only one gun per 30 yd., and may be reduced to one gun per 60 yd. at the end of the "intense" bombardment. Of these at least a third will be firing on the attacker's guns and communications, so that the defender's barrage will presumably be too thin to stop a determined attack, though it will cause a considerable number of casualties.

For this reason the defender will probably elect to use a partial barrage, that is to say, a barrage of effective density, covering only part of his front, the remainder being protected by machine-guns and trench mortars. If his telephone communications are thoroughly reliable he may be able to control this barrage so as to put it down, at a moment's notice, in front of any part of his line that is attacked. Each battery will then have, say, three alternative sets of barrage orders, so that the whole barrage can be put down on any one of three sections of the front. But this method is so complicated and so liable to break down that few commanders would care to trust to it.

As the attack gains ground the defender endeavours to keep his counter-barrage on the leading troops of the attack, and behind his retiring infantry; but owing to the inevitable breakdown of communications while the infantry are on the move it is not likely that this ideal will be completely achieved. When the defenders retire from the second zone of defence the attack will be getting within rifle range of the defender's field guns. The defender cannot afford to lose the whole of his field guns, but it is desirable that some of them, say one-third, should remain in action till the enemy is within 500 yd. of them, as they will cause heavy loss by their point-blank fire. If well supported by the guns which have already retired they have an excellent chance of getting away. As the retirement continues the medium and heavy pieces have to withdraw to the positions prepared for them in rear.

There are many details, such as the support of local counter-attacks and the protection of "strong points" which have held out against the attack, which cannot be entered upon here. Speaking generally, the object of the defender when attacked by a greatly superior force is to maintain an orderly retirement, with his line bending back but never breaking, taking heavy toll of the attacking infantry at every stage of their advance, until the attack is sufficiently weakened, or the defence sufficiently reinforced, to enable the defender to launch a general counter-attack.

*Enfilade Fire.*—It has often been suggested that the best artillery defence is that afforded by the oblique and enfilade fire of guns from adjoining sectors of the front. This theory broke down in practice. During sedentary warfare every division had enfilade sections established in its neighbours' territory, or else had a "call" on some of its neighbours' guns for enfilade purposes. So long as the line was not seriously bombarded these guns were very useful. But when the line was attacked in force it was quite hard enough to keep up communication from front to rear within a divisional area, and it proved impossible to direct the fire of the guns of other divisions. These often joined in on their own account to help a neighbour when they could see what was going on, but their assistance could not be relied on as part of the scheme of defence.

Within the divisional front the method of enfilade fire at short ranges is constantly employed; every one of the detached trenches and other works which constitute a defensive zone should be enfiladed from works in rear of it, and the approaches to it should be swept by oblique fire. This duty is chiefly performed by machine-guns, but it is advisable, when possible, to provide the batteries in rear with extra emplacements from which guns can fire obliquely or even across their front.

**Defence against Tanks.**—In describing the defence of an entrenched position, no mention has so far been made of tanks, although the use of these is now one of the most important features of the attack. And this is because the best method of dealing with attacking tanks is still a matter of speculation.

Tanks advancing against a position are screened from the aimed fire of distant artillery by the barrage which precedes them. If ordinary field guns are concealed in the front line to destroy them, these are generally destroyed themselves by the bombardment. Some tanks may be hit by the defender's barrage, but this is likely to be either thin or partial. At a later stage some of the tanks will be hit by those field guns which remain behind till the attacking infantry are within 500 yd. of them. The uncertainty of defence by mines and by ditches has been shown by experience. Tank-stopping rifles and tank-stopping machine-guns are effective against the present tanks, but those used in the next war will be proof against anything short of a gun.

It is often assumed that attacking tanks will be engaged by the tanks of the defence. But when a position is subjected to a fully organized attack the latter will not find it easy to do this. If kept well up to the front in readiness they will be destroyed by the bombardment, to which they offer large targets. If kept some 3 m. in rear till the attacking tanks appear, they will, even if their movements be correctly timed, have to pass through the attacker's bombardment and barrage, and possibly through their own barrage. Moreover, the tanks of the defence are presumably fewer in number than those assembled for the attack, so that even if they arrive in time they will be out-matched.

The best solution of the difficulty would appear to be the provision of special anti-tank guns, large enough to put an armour-piercing shell into a tank, and small enough to be provided with strong cover. A light mountain gun, capable of being divided into man-loads, would be suitable for the purpose. These guns might be in dugouts some 400 yd behind the front line, where they would not be subjected to the full violence of the bombardment. When this was lifted from the front line preparatory to the assault, the anti-tank guns would be put together and run up on to platforms level with the tops of the trench parapets, giving them sufficient command to see the attacking tanks as they charged the front line.

A regular defence in depth by anti-tank guns would have to be provided for, additional anti-tank guns being sited behind each successive line of defence, as well as in "strong points."

These anti-tank guns would have to be "silent" guns, at least so far as their own firing placements were concerned. Their provision, on a scale sufficient to stop a tank attack, would involve a considerable addition to the artillery of the defence. For even if the infantry guns of accompaniment were utilized as anti-tank guns, there would not be enough of them. Infantry guns are required at the rate of one per 100 yd. of the front of the attack, or at most 16 to a division; while if a division holds 3,000 yd. of entrenched front it will require three lines of anti-tank guns sited 200 yd. apart, that is 15 in each line, or 45, besides some 15 for "strong points." This calculation shows that 60 anti-tank guns per divisional front are required, or about one per 45-50 yards.

It may be suggested that the anti-tank guns of the first line could withdraw to the second line, and then again to the third line. But since they have to remain in position till the attacking infantry have almost reached them, in order to deal with the tanks, there would appear to be little chance of withdrawing the guns, although the detachments may be able to escape.

The expenditure of men and material for a special purpose which the above scheme involves is not to be undertaken lightly. But it has become manifest that attacking tanks are safe from distant artillery, and must be engaged by guns on the spot. Therefore these guns will have to be provided; and, so far as our present experience extends, the provision of numerous small guns in the trench area seems to be the best answer to the menace of the tank attack.

#### IV. THE PHASE OF EXPLOITATION

In France, in the latter half of 1918, after four years of trench fighting, the retreat of the invader brought the combatants into the open once more, but under changed conditions. The artillery had increased in numbers relatively to the infantry; their ammunition supply admitted of a greatly increased volume of fire, and their range had been extended. Mechanical traction, even for field artillery, had to a great extent come into use, especially in the French army, and medium, heavy and even superheavy ordnance were able to accompany the troops in the field.

Under such conditions the troops had to adapt themselves to a new method of warfare. The pre-war battery commanders, experts in mobile warfare, had been replaced by others whose training had begun in the trenches. Few of the officers and men had any knowledge of mobile warfare as thought and practised before the war, and even these found that they had to learn their work afresh.

Moreover, owing to the strain upon the munition factories manufacture had come to be limited to projectiles of simple design suited for mass production, and shrapnel had disappeared from all but the field-gun equipments. In the French army, even these had only 5% of shrapnel, the rest being H. E. shell.

The mobile phase did not last long enough for the employment of artillery in a war of masses to be thoroughly studied. The conclusions arrived at cannot be regarded as final, and are subject to possible modifications due to the more extensive use of tanks, motor artillery, and motor infantry.

**Horse Artillery.**—The old methods of manoeuvre are not applicable to a war in which the line of battle is continuous, with no flanks. Whatever the general procedure selected by the attacker, or pursuer, he will keep close touch with the defender's line, and maintain pressure on it at all points so as to deny him freedom of manoeuvre. The object of the pursued is to break away from the pursuer, and to lose touch with his troops, so as to regain freedom of manoeuvre in order to counter-attack, to take up a defensive position, or both. In this nature of warfare horse artillery are of great value. (In the coming age of motor artillery, the term "horse artillery" must be understood to mean a more mobile arm than the divisional field artillery, capable of working with the "cavalry" of the future, however that arm may be transported.) The lessons of the first phase of the western campaigns and of the Palestine campaign of 1918 still hold good.

**The Attack.**—The result of the continuous line of battle is that all attacks are, tactically, frontal attacks. Within the limits of an army corps or divisional frontal attack there will be local flank attacks; thus it is often easier to envelop a strongly held locality than to take it by direct assault. But these are minor operations which concern the trench mortars, the guns of accompaniment, and the gun-carrying tanks rather than the main body of the artillery.

Intimate co-operation of gun and sife is more necessary than ever, owing to the increased fire-power of the defence afforded by the machine-gun. The breakdown of *liaison par le bas* in the opening phase of the war has already been referred to; in the concluding phase this was still more marked, and the French especially complained that their artillery misused the increased range of their field gun by keeping far in rear of the infantry, where communication with them was impossible, instead of pressing forward to find out what was going on. But even if *liaison* is so far effective that the artillery know when the infantry is checked by fire, it does not follow that they will be able to discover the source of the fire. Possibly the infantry may not know themselves. Aeroplanes may be of great help both in locating it and in promptly conveying the information to the supporting artillery. It is even conceivable that battery commanders will direct the fire of their guns from aeroplanes. But the possibilities of "liaison by the air" are still too vague to count upon.

**The Barrage.**—Since, under present conditions, the artillery cannot always give the infantry direct support by killing the

troops that are firing on them, it is the more necessary that they should at least screen them from aimed fire. Therefore, the artillery barrage has become a feature of mobile as well as of trench warfare. Tanks also require to be screened by a barrage, although this, since it is not required to destroy opposition, may consist of smoke shell, of which a relatively smaller number suffice to create an opaque veil. Therefore, in a future attack, the artillery must be on hand so that they can be got into action at short notice, ready to form a barrage at once. But the artillery of the normal divisional establishment will barely suffice for the purpose. If it is a smoke barrage that is required, this is preferably fired by the divisional field howitzers which are the most suitable weapons. These are provided as a rule on the scale of about 16 pieces per division. If, then, the division attacks on a front of 2,600 yd., this gives only one field howitzer per 160 yd.; and at their highest rate of fire (about 10 rounds a minute for short periods, or 800 rounds an hour) they will not be able to form a smoke barrage to cover the whole divisional front; unless the weather conditions be exceptionally favourable. Similarly, for an offensive barrage of shrapnel or H. E., which requires one gun per 20 yd., the 72 field guns and field howitzers of a pre-war division would barely suffice to cover its attacking front, leaving none available for bombardment and counter-battery work. The divisional artillery must therefore be re-forecast for an attack; as in trench warfare, though not necessarily to the same extent.

This reinforcing artillery will be taken, in the first place, from reserve formations. Presumably the highly mobile army reserve field artillery will be drawn upon first, and then the artillery of the divisions in reserve. It may even be necessary to take field artillery from other divisions in the fighting line. In the days of horse-drawn artillery this would have been a dangerous expedient, but with motor artillery capable of covering 50 m. a day the objections are less serious.

**Observation of Fire.**—When both forces are on the move, there can have been no previous registration of targets. Therefore the medium and heavy artillery, which engage long-distance targets, must use aeroplane observation so far as available. Firing by the map is in mobile warfare a last resource, as there is no opportunity for the survey work characteristic of trench warfare and of the preparatory phase of the break-through battle. The mastery of the air, in order to enable ranging aeroplanes to do their work, is of the highest importance.

**Change to Trench Warfare.**—Mobile warfare is liable to turn into trench warfare at any moment; the retreating force, if not vigorously pressed, may have time to entrench a position. And even the advancing force may find it expedient to halt and protect itself by entrenchments when the strategic centre of gravity shifts to another part of the line or even another theatre of war. Therefore an advancing or retreating force must have at hand, so as to be available at short notice, the whole armament necessary for trench warfare, from heavy howitzers on railway mountings down to trench mortars.

**The Defence.**—A defensive position in mobile warfare differs from a regularly entrenched position principally by the weakness of its passive defences. Belts of barbed wire, deep trenches and dugouts, and armoured machine-gun emplacements cannot be improvised; they require time, labour and material. As regards offensive power, the chief drawback of an improvised position is its weakness in long-range artillery fire, due to the fact that firing by the map requires careful preparation, including surveying and mapping from aeroplane photographs. Another weak point is the difficulty of providing reliable communications, since deeply laid telephone cables are not available.

As above mentioned, the position consists of a system or network of localities, supporting each other by their fire, and distributed in depth as far as the strength of the force allows; thus a strong force may hold a zone 3 m. deep, with the positions nearest the enemy held just strongly enough to oblige him to deploy. A few horse artillery or mountain guns, supported by machine-guns, afford a sufficient volume of fire for this purpose. As the attacker penetrates into this network of small

positions, he finds it increasingly difficult to maintain a continuous line, with or without a barrage in front of it, and he is exposed to counter-attacks, especially from tanks which have been concealed behind cover. If he attacks *en règle* with an intense bombardment and complete barrage, he may find that he has wasted his time and ammunition on a skeleton force. His safest course is to bombard and assault each strong point in turn. But the defender will avoid the choice of conspicuous localities as strong points; an angle of a hedge affording a field of fire of only 100 yd. is better than a clump of trees on a hill. Many of the strong points will be so inconspicuous that they will have to be located by the advancing infantry and tanks before any considerable volume of fire can be brought to bear on them by the artillery in rear. In principle, the defender's methods are the same as those described earlier in this article, but the absence of the successive definite zones of defence allows of greater flexibility, especially as regards counter-attacks. The attack on an entrenched position is to a great extent a pre-arranged operation based on positive and detailed information. But when the attacker penetrates into the advanced works of a strange position, unfamiliar to him except in so far as the natural features of the country are shown on the map, he ventures into the unknown, and the advantage of surprise attack rests with the defender, if he is bold enough to avail himself of it.

On the other hand, the successful defence of a position in the open unfortified country requires a nice balance of subordinate initiative and higher control, and therefore a degree and quality of efficiency that are not always to be found in a retreating force. (H. A. B.)

## V. ORGANIZATION

Before the World War the artillery of the military Powers was organized on the following general lines: Cavalry division, one horse artillery battery per brigade of three regiments, each of 600 sabres. Infantry division of 12 battalions, six field guns (including field howitzers) per battalion of 1,000 rifles. A British division had also one battery of medium guns. Army Corps of two or more divisions, 6-in. guns and howitzers (no fixed scale), and the divisional artilleries. In the French army, a proportion of the field guns which elsewhere were assigned entirely to divisional artilleries was reserved under corps control as "corps artillery." Army of two or more army corps, all mobile guns and howitzers of calibres above 6-in. (few existed) and a siege train when required.

**Proportion of Guns to Rifles.**—The proportion of six field guns per 1,000 rifles was found satisfactory, as a normal scale, throughout the war, but extra field guns from army reserve had to be added for anything larger than an army corps operation. Opinions differ as to the strength at which this reserve should be maintained; it may possibly be fixed at 25% of the divisional artillery.

For trench warfare, the divisional field artillery had to be supplemented by the addition of pieces effective against field entrenchments. These included medium howitzers, notably the 6-in. howitzer throwing a 700-lb. shell, and medium and heavy trench mortars.

**Battery Organization.**—Before 1914, field artillery had in most countries been organized in batteries of four guns. Great Britain (for her regular army), Germany, Austria-Hungary and Italy<sup>1</sup> however, kept to the old six-gun battery. The Russians had a unit of eight guns, which could be used as two four-gun batteries. The four-gun battery is tactically more efficient; it admits of more intensive fire-direction, and is easier to lead and to conceal. Moreover, a six-gun battery rarely has occasion to use its full fire-power of 20 rounds per gun per minute, and its guns are not worked to their full capacity; better value, gun for gun, is obtained from the four-gun unit. In Great Britain, on the outbreak of war, all the batteries of the new army were raised as four-gun batteries, as were already those of the Territorial Force. But in 1916 the British army reverted to the six-gun organization; the reason given being the impossibility of providing a full battery cadre of five officers for every four guns. But it is an open question whether that cadre as conceived in Great Britain is not itself unnecessarily large. The French have only three,

<sup>1</sup> The Italians were about to introduce the four-gun battery in proportion as the Deport gun replaced the Krupp.

and in their batteries many of the duties which the British consider can only be done by an officer are performed by warrant or non-commissioned officers. The six-gun battery in peace, on the other hand, makes for economy and it is doubtless on this ground that the British authorities have decided, since the war, to retain it for field batteries.

**Distribution of Field Guns and Field Howitzers.**—In most armies, the divisional artillery consists approximately of 75% of field guns and 25% of field howitzers. It is a question whether the howitzers should be organized as a separate brigade, or whether each brigade should consist of three batteries of guns and one of howitzers. (It should be explained that the use of the term "brigade" to mean a group of three or four batteries of artillery is peculiar to the British army. Other nations restrict this term to the higher formations, commanded by a general officer, the unit corresponding to the British "brigade" being designated *groupe*, *battalion*, *Abteilung*, *division*, etc.)

The Germans, in 1914, distributed their howitzer batteries among the gun brigades, but later on, they reverted to separate howitzer brigades in the proportion of two gun and one howitzer brigade per division, the three batteries of each being all on the four-gun basis. The British broke up their howitzer brigades and distributed the batteries in 1916, and retained these mixed brigades to the end of the war. The difference in the training of the men is slight, and is concerned principally with the extra complication of the divisible charges used in howitzers. Now that it is proposed in most armies to use half-charges and super-charges as well as normal charges for long guns also, this difference is tending to disappear. During trench warfare, a howitzer brigade was never used as a fire-unit; its batteries were distributed along the divisional front. In mobile warfare, there are many occasions when the fire of field guns requires to be supplemented by that of field howitzers, and few, if any, when a field howitzer brigade would be used alone. Assuming that the field howitzer is a light piece of the same mobility as the field gun, it appears that the mixed gun and howitzer brigade, consisting of three batteries of guns and one of howitzers, is the better organization of the two.

**Fighting Organization of Artillery during the War Period.**—For the standards of 1914, three types may be taken as representative; the German, the French and the British. Field and heavy field batteries only will be considered.

The German army corps of two divisions possessed 144 field guns and field howitzers, and 16 heavy field (6-in.) howitzers. Only the latter named were corps troops, all field artillery being divisional. Each division possessed a field artillery brigade of two regiments, each regiment having two *Abteilungen* of three six-gun batteries each. One of the four *Abteilungen* in each division was armed with 105-mm. (4.1-in.) field howitzers, the other three with the 77-mm. field gun. The corps heavy artillery formed a "battalion" of 4 four-gun batteries. In the field artillery, the battery, besides its six guns, possessed nine ammunition wagons, and in all 17 vehicles. The personnel was 190 of all ranks with 135 horses. The *Abteilung* had 480 officers and men, 400 horses and 53 vehicles. The light ammunition column, of which there was one for each *Abteilung*, had 190 officers and men, 180 horses and 24 vehicles. In addition, there was the field artillery component of the less mobile ammunition column allotted to the division. The heavy battery (230 officers and men) in addition to its four guns had eight ammunition wagons and seven other vehicles, with 120 horses in all. The battalion of four batteries numbered 960 officers and men, 520 horses and 80 vehicles. A light ammunition column of 29 vehicles, 270 personnel and 190 horses carried the first reserve and a slow-moving column the second. Heavier artillery, some of which (21-cm. mortar batteries) had for many years been organized for rapid movement, was allotted to armies as required.

The French artillery was divided into divisional and corps artillery, armed uniformly with the 75-mm. gun. The few heavy batteries available were army artillery and there was no light howitzer. The field battery had four guns and no less than 12 ammunition wagons, with six other vehicles. The personnel was three officers and 170 other ranks with 165 horses. The *groupe* consisted of three batteries, with a total of 544 men (including 16 officers), 514 horses and 71 vehicles. The first ammunition reserve was an "artillery ammunition section" of 20 ammunition wagons (half slow-moving) and other vehicles. Each division had a regiment of artillery consisting of three *groupes* and each corps, as corps artillery, a regiment of four *groupes*; there were thus 10 *groupes* or 30 batteries (120 guns) per corps.

The British army in 1914 did not possess the corps organization, and some elements usually under corps control were in this instance divisional, especially the heavy field artillery.

The divisional artillery was under the command of a brigadier-general and consisted of three "brigades" (of three six-gun batteries each) of 18-pr. guns, and one brigade (similarly constituted) of 4.5-in. howitzers, plus one four-gun battery of 60-pr. heavy field guns. The battery had two ammunition wagons per gun, making with other vehicles a total of 20. The battery personnel numbered 200 including

five officers, with 174 horses. To each brigade was attached permanently a light ammunition column, consisting of a third ammunition wagon per gun, and 13 vehicles of different sorts for infantry ammunition. In all, the brigade with its ammunition column had 803 officers and men, 764 horses and 102 vehicles. The organization of the howitzer brigade was practically identical, except that its ammunition column did not supply infantry, so that the total of vehicles was smaller, viz. 80. The strength in personnel was 763 and in horses 719. The heavy battery had 19 vehicles including its guns, and possessed an ammunition column of its own, consisting of a third ammunition wagon for each gun and one other vehicle. Thus in all, the unit had 24 vehicles. The personnel of battery and column together was six officers and 192 other ranks with 144 horses. The divisional ammunition column consisted of 113 general service wagons (of which 81 were for artillery ammunition, 18 for infantry and one for special stores), personnel 15 officers, 553 other ranks, horses 709.

A general comparison of artillery strengths in men, horses and vehicles (excluding those allocated to the service of infantry ammunition) shows the following—

- Great Britain (two divs.)  
7,640 officers and men, 6,436 horses, 996 vehicles, incl. 152 guns.
- France (corps)  
7,750 officers and men, 6,737 horses, 943 vehicles, incl. 190 guns.
- Germany (corps)  
7,830 officers and men, 6,850 horses, 975 vehicles, incl. 160 guns.

(In all the above figures, supply and baggage wagons have been included.)

This organization, designed for mobile warfare, broke down under trench warfare conditions. The organic artillery allotment of the division proved to be too large for normal trench warfare fighting and too small for battle. The army corps itself, as a standard unit, gradually ceased to exist, and was changed into a new form of army corps which—generally fixed in a particular area of the front—constituted a permanent framework, in and out of which different divisions constantly passed from "line" to "rest" and *vice versa*. The exhaustion of the fighting energy of infantry and of artillery respectively when the line proceeded at different rates, and the infantry of a division frequently had to be withdrawn and replaced by that of another while its artillery remained in position. The growth of the "dump" system of ammunition supply rendered the elaborate organization of horse-drawn ammunition reserves largely uneconomical. Lastly, the range of guns permitting of artillery collaboration between adjacent divisional sectors—especially for counter-battery work—a common organization for the command of the artillery of several sectors was bound to come into being.

In the British, French and German artillery, accordingly, the divisional field artillery was reduced to a strength suited for a divisional sector in trench warfare; this artillery went in and out of line with its division. The remainder of the field artillery was formed into a mass of "army reserve artillery," the function of which was to double, treble or quadruple the divisional artilleries in a battle area. This reserve, being wholly independent both of the area organization and of the divisional formation, could be brought into action as required and for as long as required. The medium and heavy artillery, similarly, was divided into two portions, but the change was here less obvious, as little or no artillery of these classes had belonged organically to divisions. The one portion was substantially fixed to the area, the other placed in army reserve and used to reinforce the area heavy artillery for battle periods.

The following diagram illustrates the evolution just described—

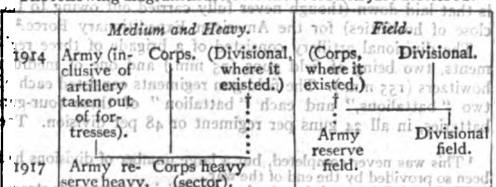

1 The reservation is necessary as some nations have no light field howitzers, and use the 6-in. as the divisional high-angle weapon.

2 Neither the French nor the German first reserve columns supplied infantry ammunition.

The effective solution that this reorganization provided for the problem of divisional reliefs, and incidentally the necessity for some such solution, are illustrated by the fact that in the prolonged Flanders battle of July-October, 1917 the average time spent in line by divisional artillery (which moved in and out with their infantry) was 33 days, while the average for units of the army reserve field artillery was 72 days.

When fully developed—at the end of 1917—the higher organization of the British artillery in France was as follows:—

other had three "battalions" each of two four-gun batteries, making 24 medium howitzers. Thus, as in 1914, we find 72 guns per 12 battalions or six guns per 1,000 rifles, but the addition of numerous heavy machine guns to the rifle strength makes the proportion of guns, in relation to fighting frontage, somewhat less. Each divisional artillery possessed a battery of 12 medium trench mortars.

The corps artillery (each corps had four divisions) comprised one regiment of medium guns (4.7 in.) and one of heavy guns

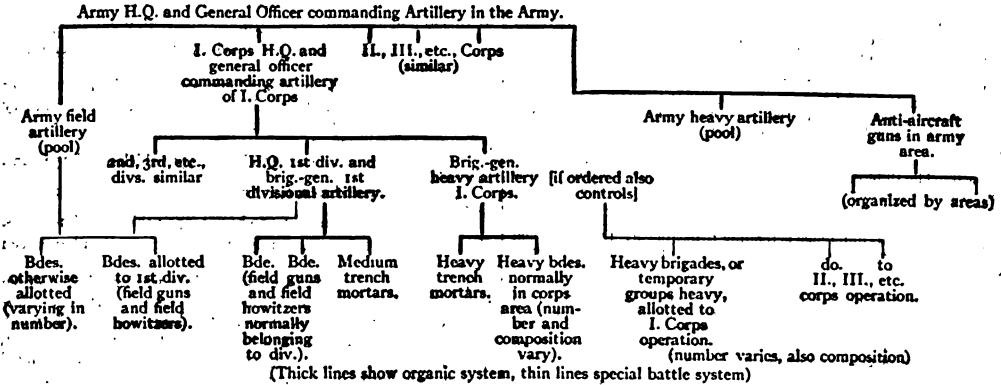

(At this period the field brigades were composed of three gun and one howitzer battery each; the composition of heavy brigades varied considerably, a "mobile" brigade consisting of two 60-pr. and two 6-in. howitzer batteries, while others contained 9.2 and 8-in. howitzers in addition.)

German practice differed considerably from this, in that all artillery in a divisional area was under control of the divisional artillery commander, while in major operations the artillery of several corps together was controlled for the occasion by a "general of the artillery" who was often neither a general officer in rank, nor a permanent member of the army headquarters concerned.

The average strength in batteries of a divisional sector (in the case of the German nine-battalion division) was—the six field-gun and three field-howitzer batteries of the division, and five to seven batteries of medium and heavy artillery belonging to the sector, or, in pieces, 36 light plus 24 heavy (irrespective of trench mortars). Figures have already been given for typical artillery strength in battle (in terms of yards of front per gun).

The return to open warfare conditions in 1918 made further changes, chiefly in the direction of providing divisions with medium artillery of their own and separating what had formerly been "sector" heavy artillery into calibres suitable for incorporation in mobile divisions and calibres best managed by corps headquarters. The Germans made a beginning with this process in permanently allotting a group of one 10.5-cm. gun battery and two 15-cm. howitzer batteries to each divisional artillery.<sup>1</sup> But the best example of artillery organization as conceived in 1918 for purposes of the expected mobile warfare, is that laid down (though never fully carried out owing to the close of hostilities) for the American Expeditionary Force.<sup>2</sup>

The divisional artillery consisted of a brigade of three regiments, two being of field guns (75 mm.) and one of medium howitzers (155 mm.). The field-gun regiments consisted each of two "battalions," and each "battalion" of three four-gun batteries, in all 24 guns per regiment or 48 per division. The

(155 mm.) both "motorized," as well as four batteries of heavy trench mortars. These artillery regiments were arranged, like the medium regiment of a division, in three battalions each of two four-gun batteries; thus in all, the corps artillery contained 24 medium and 24 heavy long guns. The two regiments formed a brigade.

Army reserve artillery (for an army of five corps or 20 divisions) consisted of four brigades (motorized) or 12 regiments of heavy guns (6-in.), organized as above, and containing in all 288 pieces, and five regiments of field artillery (organized in the same way as divisional field artillery regiments) with 100 pieces.

Lastly, under G.H.Q. direct was the Railway Artillery Reserve, consisting of 42 batteries (i.e. pieces) grouped in "battalions," regiments and brigades.

Neglecting the last item, then, we find for an army of 20 divisions, about to be engaged in offensive mobile warfare and counting 291 battalions of infantry and pioneers and 120 regimental and divisional machine-gun companies:—

Field guns.	Medium howitzers.	Medium guns.	Heavy guns.
230 batteries divisional, 120 battalions in army pool.	120 batteries divisional artillery.	120 batteries corps artillery.	120 batteries corps artillery, 72 batteries in army pool.
= 1,440 pieces	= 480 pieces	= 480 pieces	= 768 pieces

Total batteries 992; total pieces (excluding Railway Artillery and trench mortars) 3,168; or roughly 10 guns per 1,000 of infantry, pioneer, and machine-gun establishments, of which 43 belong to divisional, 3 to corps and 23 to reserve artillery.

In the British and American examples quoted, an artillery staff under a brig.-gen. or maj.-gen. is provided at the rate of about one per 90 guns (or including the field artillery pool one per 100). The German artillery staffs were in a smaller proportion. This question of higher artillery commands is still an open one, but it is clear that under modern conditions no reversion is possible to the simple method of 1914, in which there was no effective artillery staff at a higher level than the division. War organization will necessarily include some proportion of these higher artillery commands, and peace organization must provide, if not these executive posts themselves, at any rate the means of preparing the officers who may be called upon to hold them.

<sup>1</sup> This was never completed, but a large number of divisions had been so provided by the end of the war.

<sup>2</sup> It must be observed that the American division was much stronger in infantry than a British, French or German, having in fact 12 battalions besides a considerable machine-gun organization.



**Ammunition Supply.**—Before the war all armies were equipped with mobile ammunition columns, which served the needs both of infantry and machine-guns and of the artillery itself. As a rule certain columns in each formation were supplied with limbered vehicles and field artillery horses, and were as mobile as the batteries, while the remainder, with vehicles of the ordinary army type, possessed the mobility of baggage columns only. In Great Britain a considerable advance toward simplifying the ammunition supply service had been made by introducing lorry transport, worked on the same system as that which provided the army's daily bread, and by attaching a light ammunition column permanently to every brigade of field artillery. But when trench warfare set in, and all supply at the front was based on a system of "dumps," the mobile reserve of ammunition constituted by these brigade ammunition columns was not required. They were therefore put back into the "divisional" ammunition column, or second echelon of supply, which itself was recast on a much smaller scale.<sup>1</sup> In the more open warfare of 1918, however, it was found necessary to return a portion of them to divisional control.

The batteries themselves retained, and necessarily so, all their original wagons.

The organization, and nature of transport, required for reserve ammunition in the future depends principally on the organization and motive power of the batteries. But it may be assumed with some confidence that since mechanical transport improves every year in available numbers, trustworthiness in different conditions, and freedom of movement, horsed ammunition columns are a thing of the past. Even theatres of war for which mechanical transport is unsuitable to-day will be open to it to-morrow.

**Organization of Artillery Motors.**—During the war the personnel in charge of the artillery motor lorries, tractors, and other motor vehicles were not artillerymen, but were taken from the transport services. This was only a provisional arrangement, due to the fact that the artillerymen were not competent to take charge of motor vehicles. As the motor replaces the artillery horse, this incongruity will naturally disappear, and the artillery will drive their own motors. This will presumably not apply to lorries used to transport guns behind the fighting line, as described above, since these lorries will be general transport, available for other troops when not employed with the artillery. The leading principle is that all men who go into action with the guns, or who are available to replace casualties in the fighting line, must be artillerymen.

**Special Artillery and Scientific Auxiliaries.**—The introduction of guns of accompaniment, to advance with the front line of the infantry, is contemplated in all armies. The question arises whether these guns are to belong to the infantry, like their own machine-guns, or to the artillery. It is urged on the one hand that the special knowledge required to use a field gun is such as the infantry cannot be expected to attain. On the other hand, infantry officers point out that the gun is not required for general artillery purposes, but merely as a large-bore machine-gun, and that the detachment must be thoroughly familiar with infantry work. The decision between these two views seems to depend on whether the guns of accompaniment are to be used as batteries or as single guns. In the latter case, they should be infantry, not artillery, weapons.

A more difficult question is whether tanks armed with guns are to belong to the artillery or to a separate tank corps. It is easy to draw the line between a fighting tank which has a gun as part of its armament, and a tractor which pulls a gun into action and then waits behind like a limber and team. These are the two extremes, but there are intermediate forms, such as the tank which carries a gun on a platform, capable of fighting either on top of the tank or on the ground, and the tank which is an integral part of the gun-mounting, and is technically an automobile gun-carriage. It seems probable that all these types

<sup>1</sup> In the new organization, that part of the divisional ammunition column which carried the second reserve of gun ammunition was reduced to one-seventh of its former size.

will belong to the artillery, except the tank proper, in which the gun is only a subsidiary part of the armament.

Finally, it is significant that in reducing the artillery to the minimum imposed by the Peace of Versailles, Germany has chosen to retain both accompanying guns, anti-tank guns and scientific sections (flash-spotting, sound-ranging, meteorological and survey) on the regular establishment of the arm.

(H. A. B.; C. F. A.)

## VI. THE EFFECT OF ARTILLERY PROJECTILES

It is of great importance to the soldier to know the probable effect of artillery projectiles. On the one hand, the artillery commander must know what nature of projectile to use for a given task, and how many will have to be fired, and, on the other, the troops must know what measures to adopt in order to escape the shell-effect, or to minimize it.

The projectiles fired by land artillery are shrapnel shell, H.E. shell, and chemical, incendiary and illuminating shell. They may also have to fire armour-piercing shell at armoured forts and at tanks, though these shell are not part of their usual equipment.

**Shrapnel Shell.**—This is the most efficient man-killing projectile against troops exposed in the open or when manning a parapet. The French calculate that in 1914, when their artillery fired little but shrapnel, they killed five men of the enemy for every ton of ammunition expended, whereas in 1918, when, after a long period of trench warfare, the proportion was only 5% of field artillery shrapnel to 95% of H. E. shell, they killed only one man per 4 tons of ammunition. The reduction in the proportion of shrapnel carried was due to the difficulty and expense of supply, especially as regards the fuse. The object of the designer of gun and ammunition, and of the gunner who uses them, is to obtain a dense shower of bullets flying forward close to the ground.

With a view to shrapnel effect, the gun-designer produces a gun with high velocity, long range, and flat trajectory. But a gun equipment of given weight can produce only a given amount of shell energy, which is measured by the product of the weight of the shell and the square of its velocity. Consequently there must be a compromise between a heavy shrapnel and a light high-velocity one. This has been solved differently by different nations, as follows:—

	Weight in Action of Gun cwt.	Weight of Shrapnel lb.	Muzzle Velocity fs.	Number of Bullets to the lb.	Number of Bullets in Shrapnel.
Russia	21	14½	1,930	43	260
France	23	16	1,740	38	292
Great Britain	24½	18½	1,615	41	75
Germany	18½	15	1,525	45	300

The Russian and French guns are best adapted for shrapnel fire. The French use a heavy far-reaching bullet, which, in their flat-trajectory gun, gives a deep zone of shrapnel effect, suited to their bold method of opening fire, which is intended to produce a crushing effect on the enemy with the least possible delay. The Germans were obliged by the low power and curved trajectory of their field gun, in which muzzle energy was subordinated to mobility, to abandon the idea of a far-reaching shrapnel and to accept the necessity of expending more rounds for searching a given depth.

Another consideration affecting the question of high velocity versus heavy shell is that the light shell loses its high remaining velocity, which gives the forward impulse to the bullets, much sooner than the heavy shell, so that much of the power of the gun is wasted on overcoming air-resistance, instead of being communicated to the bullets. However, it maintains the initial advantage due to a low angle of elevation up to extreme shrapnel range. The loss of remaining velocity can be partly compensated for by increasing the driving charge in the shell. The shrapnel then acts as a short gun fired close to the enemy. But although this expedient is adopted to some extent in most equipments the limit of efficiency is soon reached, since the large charge reduces the bullet capacity of the shell, and the body has to be made with stout walls, or of very high-grade steel, not always available in war-time, to prevent the shrapnel from blowing to pieces instead of acting as a gun.

**Weight of Shrapnel Bullets.**—The weight of the shrapnel bullet, which is necessarily spherical, is of great importance to the effect. Elongated shrapnel bullets are out of the question, since there is no means of imparting rotation to them. All attempts in that direction have been failures. Of two spherical bullets the heavier will travel further before pitching into the ground, and so will have a longer period of efficiency. The heaviest metal practically available for shrapnel bullets is hardened lead. Tungsten and other heavy metals have been proposed, but are not available in sufficient quantities for

war requirements. The weight of the shrapnel bullets contained in a shell can therefore be increased only at the expense of their number.

In the other direction, the minimum weight of the bullet is determined by the necessity for providing sufficient disabling energy. It has been found experimentally that a striking energy of 60 foot-pounds is sufficient to disable a man. In the case of a bullet starting from the point of burst with an initial velocity of 1,000 ft., as in the British 18-pr. at 4,000-yd. range, the striking energy after it has travelled 300 yd. is as follows:—

	Weight of Bullet.	Remaining Velocity.	Striking Energy.
France	38 to the pound	388 ft.	61.5 foot-pounds
Russia	43 " " "	398 " "	52.8 " "
Germany	45 " " "	370 " "	47.2 " "

It will be seen that under the assumed conditions the French bullet of 38 to the pound is the only one which provides sufficient striking energy at 300 yd. from the burst. Of the nations which took part in the World War, the French, the Japanese, and the United States (who had the French equipment) were the only ones who used the heavy shrapnel bullet. The other nations (except the Russians) considered that the trajectory of their guns was not flat enough to carry a good proportion of the bullets to a distance of 300 yd., and consequently preferred lighter but more numerous bullets which gave a closer pattern over a shorter distance. It would seem that the Russians, with their powerful gun, would have done better to use a heavier bullet.

**Technical Employment of Shrapnel.**—A shrapnel should be burst in air so that the axis of the bullet-cone passes through the centre of the target. This is a matter of ranging, and is dealt with elsewhere. Further, the distance of the point of burst from the target should be such as to produce the greatest possible effect. This also is a matter of ranging, but the gunner must first know what is the correct distance which he has to attain. This is determined by theory.

The target surface of a man, measured at right angles to the trajectory of a shrapnel bullet, may be taken as  $\frac{1}{4}$  sq. yd. when standing,  $\frac{1}{8}$  sq. yd. when kneeling, and  $\frac{1}{16}$  sq. yd. when lying or firing over a parapet. The best effect is produced when the density of the cone of bullets is such as to provide one effective bullet for each man. The density depends on the target surface offered by each man; it is immaterial, as regards the best distance of burst, whether the men are in a thin skirmishing line or shoulder to shoulder. If the distribution of bullets throughout the cone were uniform—that is, if the shrapnel gave a perfect "pattern"—then at standing infantry the cross section of the cone should contain one bullet per  $\frac{1}{4}$  sq. yard. Taking a shrapnel containing 300 bullets, the cross section of the cone at the target would have to be 150 sq. yards. The apex angle of the cone being about  $1^\circ 4'$ , this would fix the best distance of burst at 55 yd. from the target. But the distribution of bullets in the cone is not uniform. If it be assumed to be haphazard (which is nearer the truth), then, according to the Theory of Probabilities, the probable maximum effect is produced when the cross section contains 1.24 bullets for each man. This gives the best distance of burst for the above shrapnel as about 50 yd. against standing men, 41 yd. against kneeling men, and 35 yd. against men lying or firing over a parapet. With the shrapnel of the British 18-pr., which contains 375 bullets, the best distances are 55, 45 and 38 yd. respectively.

The question of the distance of burst is affected by the error of the fuzes. If, for instance, the fuzes be such that the shrapnel is liable to burst 60 yd. over or short of the desired point, then if this be fixed at 40 yd. from the target some of the shrapnel will be wasted by bursting on the ground. Similarly, the error of the gun will cause "short rounds to burst on the ground. In the British and in the French services it has been laid down that the distance of burst for field guns is to be such as to appear from the battery 10 minutes of angle (in French notation  $3'$  "mils," i.e.  $\frac{1}{10}$  of the range) above the target. This corresponds to a distance of burst of 70 yd., and rather less at longer ranges, and gives about 10% of bursts on graze. This distance has been fixed partly with reference to the error of the fuzes (which, under war conditions of manufacture, is considerably greater than in peace time), but principally for simplicity. When good fuzes are available better shooting is to be obtained by adhering to the theoretically correct distances given above. Towards the end of the war the Germans used a number of very accurate mechanical time fuzes, and if these came into general use the service height of 10 minutes above the target will no doubt be reduced.

**Penetration.**—Even the heavy French shrapnel bullet will not pierce the thinnest of the steel gun-shields in use, and it is quite ineffective against infantry shields, loophole plates, and the plates of a tank. These shields are all made to resist infantry bullets, which have much greater power of penetration than leaden shrapnel bullets.

Steel shrapnel bullets will pierce gun-shields if the shrapnel be burst close up.\* As the steel bullets are larger than leaden bullets of the same weight, their use entails a reduction of about 20% in the number of bullets in the shrapnel. For the same reason they do not fly so far, and shrapnel filled with them are less effective against

\* These were actually used to a small extent by the Germans towards the end of the war, possibly on account of shortage of lead.

infantry: Tungsten steel bullets containing 14% of tungsten would be as heavy for their size as bullets made of the ordinary lead-antimony alloy, but difficulties of expense and supply will probably prevent their introduction.

**Percussion Shrapnel.**—Shrapnel are invariably fused with time- and-percussion fuzes, constructed to burst either in air or on graze. The object of the percussion arrangement is almost entirely to assist ranging by giving visible bursts on the ground. The bullet-effect of shrapnel burst on graze is negligible, as the shell rises steeply from the crater before it opens, and the bullets are blown out in an upward direction, and lose their effective velocity before coming down again. Occasionally the ground may be so hard and the angle of impact so small that the shell ricochets low instead of forming a crater and shower, viz. upwards. But generally speaking percussion fire with shrapnel at troops in the open is a waste of ammunition.

When a direct hit is made with a gun-shell the shell does not open till it has travelled several feet further, unless it hits the gun or some solid part of the carriage, and there is no bullet-effect on the detachment. As a rule, a direct hit from a field shrapnel on a modern cellular ammunition box does not blow up the contents, though it may explode a H.E. shell if it makes a fair hit on it, and it may set fire to some of the cartridges.

When percussion shrapnel are fired at a building the shell explodes as it passes through the wall, and produces good bullet-effect on anything behind, as in this case the check is insufficient to give the base burst time to ignite. It used to be held that troops were safe from shrapnel behind two walls, and this is literally correct, but there are so many windows in the front of a house that the shrapnel is liable to pass through them and burst through the back wall, and moreover, under the fire of powerful modern field guns the front wall soon ceases to exist.

Owing to the charge of black powder which it contains shrapnel has considerable incendiary effect on buildings.

**Howitzer Shrapnel** produces its characteristic effect by the bullets striking downwards at a steep angle 40 degrees or more to the horizontal. The object is to reach troops behind a parapet or gun-shield. The depth of effect, being proportionate to the cosine of the angle of impact, is much less than with a flat-trajectory gun. Precise ranging and an accurate fuzes are required to produce good effect. During the first or mobile phase of the war shrapnel fire from field howitzers gave excellent results; later, however, the difficulty of procuring good time fuzes for howitzers brought this class of shell into disrepute, and it seems probable that its use will be discontinued except for light field howitzers, and even in these reserved to mobile warfare.

The theory of the effect of howitzer shrapnel is the same as for gun shrapnel. The weight of the bullet is increased to compensate for the low remaining velocity. The angle of descent of the lowest bullet, including half the angle of opening, is about 40 degrees to the horizontal, so that a man would have to crouch very close behind a gun-shield or parapet to escape being hit. When burst at effective height a field howitzer shrapnel, such as that of the British 4.5-in. howitzer, covers a space 35 yd. wide and 70 yd. from front to rear.

**Universal Shell.**—These are combined shrapnel and howitzer shell; a type is described and illustrated in 1.869. The idea is that when burst in air at shielded guns the head flies forward and acts on impact as a small H.E. shell, powerful enough to disable the gun if it strikes it, or to reach the men behind the gun-shield with splinters flying sideways or even backwards, while the body of the shell acts as an ordinary time shrapnel. If the whole shell is burst on impact it detonates like a H.E. shell. Such shells were used in the war, but their usefulness was always a matter of controversy and their complicated design made supply difficult.

**High-Explosive Shell.**—These were the principal projectile fired by all natures of land artillery during the long period of trench warfare in the western theatre of war. They are of two kinds, thick-walled shell and mine shell. The former have a comparatively small burster and are intended to kill men with their splinters; the latter are thin-walled shell containing a large burster, and are intended to penetrate deeply before bursting, and to destroy fortifications and material. Mine shells are fired from howitzers, in which they are exposed only to a low pressure in the bore. In modern howitzers, which are required to range at least 50% further than those in use in 1914, the endeavour is made to keep down the pressure as far as possible by increasing the length of bore, thus getting more work out of the same charge. But the increase of range which can be obtained in this way is hardly sufficient, and heavier charges are inevitable. Mine shells for such pieces have to be made thicker in the walls to prevent them from collapsing in the bore, and tend to approximate to the thick-walled type.

Thick-walled shell are almost always fired with instantaneous percussion fuzes; occasionally they are fired with time fuzes to burst in air. The object of the instantaneous fuzes is to burst the shell on the surface of the ground before it has time to penetrate, so that the splinters are not wasted by being smothered in the crater. Thus, early in the war, the German howitzer shell, for want of an efficient instantaneous fuzes, used to penetrate deeply into the soft clay of Flanders, and the result was a vertical eruption of mud and splinters which was harmless to men not actually on the spot struck. Instantaneous fuzes are also used to burst H.E. shells in the act of passing



through a gun-shell, thin wall, thin parapet, etc., so as to produce splinter effect on troops immediately behind it. When an instantaneous fuze acts properly the effect, even on soft ground, is to form a saucer-shaped crater not more than 6 in. deep, in which no splinters are to be found. With flat-trajectory guns the splinters fly forward and sideways, and no reverse effect on troops behind cover can be expected; with howitzers fired so as to give angles of descent of 30 to 45 degrees a few splinters from the base come back, but the reverse effect is slight; with howitzers fired at angles of elevation between 45 and 65 degrees, giving angles of descent of 55 to 75 degrees, the effect is almost equal in all directions.

The size and weight of the splinters are of great importance. Owing to their irregular shape small splinters do not fly very far. The object of the ammunition designer is to get as many effective splinters as possible. As the result of experiments it is considered that the best man-killing weight is 25 grammes (0.88 oz.), though splinters as small as 10 grammes (0.35 oz.) may be effective close to the point of burst. It is not always possible to realize this ideal; the French field gun H.E. shell, weighing 11.68 lb., gives only 50 effective splinters, averaging 100 grammes (3.52 oz.). The German 1914 field-gun shell, weighing 15 lb., gave 135 splinters averaging 1.65 ounces. A more recent projectile, that of the French 7.7-pr. trench gun, gives 90 splinters of about 1.2 ounces. Theoretically it is possible to design a shell so as to produce any required fragmentation. A violent H.E. burster tears a soft metal shell to minute fragments, while a mild burster in a hard steel shell merely breaks it into a few large pieces; the designer has to adjust the violence of the burster to the hardness and "shock-test" strength of the steel so as to produce the desired number of fragments, as uniform in weight as possible. But in practice the problem is a difficult one, as the stresses to which the shell is subjected in the gun, and the shape and balance desirable for ballistics, have to be taken into account. However, manufacturers produce a fair approximation; thus Krupp claimed to get 20 splinters of 25 grammes and over per kilogramme of field-gun shell, or about 9 per pound.

The French field-gun shell is effective over an area of 25 sq. metres only, but with larger calibres much better effect is obtained. Roughly, a 6-in. howitzer shell, weighing 100 lbs., clears an area of 300 sq. yards.

During the war considerable success was obtained in firing thick-walled H.E. shell from flat-trajectory guns with percussion fuzes giving a slight delay action, so as to burst in ricochet in the air from 20 to 30 ft. above the ground. Ricochet fire is applicable only when the angle of impact is so small, and the ground so hard, that the shell has no tendency to bury itself. With an angle of opening of about 120 degrees the downward and lateral effect is good, and the forward effect is appreciable, though far inferior to that of time shrapnel. This method was evolved by the French before the war; the ricochet effect is styled the "*coup de hache*." It was used also for wire-cutting.

**Mine Shell.**—With howitzers above 6 in., mine shell, not man-killing shell, are usually employed. With medium and heavy guns mine shell are not used except at long ranges, where the angle of descent is steep enough to ensure deep penetration, and even so, for the reason above given, they have to have fairly thick walls and lose correspondingly in explosive capacity. Heavy high-velocity guns therefore usually fire only shell of the thick-walled type, bursting on graze and producing effect by the action of heavy splinters. There is now, however, a tendency to employ reduced as well as full charges with guns, in order to save wear, and with these it will be possible to use efficient mine shell.

The burster of a mine shell is of such a nature as to do as much work as possible in displacing earth. A very violent explosive of the fulminate type, even if it could be used, would be less effective than T.N.T. or amatol (see AMMUNITION) because its action is too local, and much of the force of the explosion would be wasted on pulverizing the earth at the point of explosion instead of shifting it. The fuze has to be made with a delay suitable to the ballistics and to the nature of the ground; if the shell penetrates too deeply it forms a "globe of compression" or hollow chamber beneath the surface, while if it does not penetrate deeply enough much of the energy is wasted on the air. The mine shell of the German 15-cm. (5.9-in.) howitzer was effective; it penetrated to a depth of 3 to 4 metres, at which depth its burster of 18 lb. of picric acid gave good mine effect.

**Effect on Tanks.**—Fire from all natures of guns and howitzers is effective on unarmoured or lightly armoured tanks. The best projectile is H.E. with normal or instantaneous fuze, as the delay action fuze is liable to cause the shell to pass right through and out again before it bursts. In one instance during the war a German tank protected by 30-mm. (1.18-in.) hard steel armour was fired on by British 18-prs. firing ordinary thick-walled H.E. shell at ranges of 3,000 to 4,000 yards. It was disabled, and on examination it was found that several of the shell which had struck it had just failed to penetrate. The effect obtainable with armour-piercing shell is described below.

**Effect on Armoured Forts.**—The penetration of armour is discussed under **Armour-Piercing Shell**. But this is not the only means of reducing an armoured fort. The Germans obtained effect on the Belgian forts in 1914 chiefly by "undermining" fire. The mine shell of their superheavy howitzers, with delay-action fuzes, buried themselves almost under the foundations of the cupolas, and either blew

the latter up and out of their seatings, or racked the whole concrete mass so severely that the machinery was put out of action. Or, again, they ruined and blocked up the vaulted passages and so prevented access to the cupola chambers.

In future constructions it has been proposed to guard against this method of undermining by extending and strengthening the apron surrounding the cupola. The ground for 50 metres round it is to be protected by one or more layers of blocks of hard cast-iron, one metre cube, each weighing 8 tons. These are to be sandwiched between layers of concrete, and are expected to burst all shell on the surface. This method, if applied, will probably be effective against undermining. There remains the possibility of damaging the projecting muzzles of the guns with heavy splinters from thick-walled shells, and of penetrating the armour with armour-piercing shell from high-velocity guns. An attack with gas is also possible.

**Effect on Field Entrenchments.**—Gun emplacements and dugouts require a "bursting course" of rails or stones at or near the surface of the earthen roof, otherwise the emplacements are easily penetrated: Even a field-howitzer shell with delay action will go through 5 ft. of earth and blow in a timber roof beneath it. Double roofs of rails with an air-space of 8 to 12 in. between them are used when possible, and such a roof, with 5 ft. of earth and a bursting course on top of it, is fairly safe against a single hit from a 6-in. howitzer shell. For protection against 8-in. and heavier natures it is necessary to burrow 20 to 30 ft. underground.

**Concussion and Asphyxiation Effects of H.E.**—A mine shell of 6-in. calibre and upwards does great damage when burst inside a building, dugout, or other confined space, by the force of its blast, irrespective of splinter effect. The same effect, to a lesser extent, is produced by thick-walled shell. Walls of buildings are blown out, and men in the room in which the burst takes place are killed by the concussion. The idea that "poisonous" gases are produced by the detonation of high explosives is a mistake; only small quantities of carbonic acid gas and carbonic oxide are generated, and these, except in a deep dugout, are quickly dissipated by the rush of air which succeeds the blast. However, it was found at Liège and Antwerp that the deeply sunk ammunition rooms below the armoured forts were rendered uninhabitable by the fumes from mine shell filled with picric acid which penetrated them or burst underground near them. These were presumably acid fumes due to the incomplete detonation of the bursting charges.

**High-Explosive Shell with Time Fuzes.**—These were originally introduced for the German field gun, in order to attack troops in deep trenches. The method used was to burst the shell exactly over the trench, and to obtain effect by splinters striking downwards. But even under peace conditions of precision of fire it was found that an average of four shells were required to hit one man, and under war conditions the expenditure of ammunition was out of all proportion to the effect produced. In the war, the Germans occasionally used time H.E. shell for annoyance, on account of their supposed moral effect on troops in trenches. Their use ceased altogether when time and percussion fuzes for H.E. shell were withdrawn. A H.E. shell has little or no incendiary effect.

**Smoke Shell.**—These are used to form a screen between our troops and the enemy. In barrage fire time shrapnel produce quite enough smoke to make an opaque screen; but when a barrage is formed with H.E. shell, these are mixed with 25% of smoke shell to make a good screen. This method was frequently used by the French, either because of shortage of field shrapnel, or because the barrage was carried beyond shrapnel range.

**Incendiary Shell.**—During the retreat the Germans used these shell to set fire to villages which they had evacuated. Some were of the ancient "carross" type, filled with black powder and grease, and spouting flame from holes in the walls; others were filled with petroleum. The British introduced *thermit shell*, filled with aluminium dust and iron oxide, which, when ignited, form molten iron. The filling consisted of short cylinders of thermit, like firework stars, and the shell was preferably burst in air like a shrapnel, so as to blow the stars out forwards. These were used to a small extent in the Allied advance towards the end of the war, and gave good results.

**Illuminating Shell.**—These contain firework stars, which are ignited by a time fuze at such a height as to give them time to burn out before reaching the ground. They are fired principally from field howitzers.

**Armour-Piercing Shell.**—These may have to be used against armoured tanks, and turrets and cupolas of land defences.

The effect of field gun armour-piercing shell against tanks depends not only on the thickness of the armour but on the manner in which it is supported, and the angle at which it is struck. The following table of penetration for the British 18-pr. gun used in the war may be taken as a guide. It is assumed in the table that the armour is efficiently supported and that it is struck at an angle not exceeding 30 degrees to the normal. The formula is:—

$$t = \frac{2500 - 4v}{v} \quad \text{or} \quad v = \frac{2500 - t}{4}$$

where  $t$  is the thickness of hard-faced armour in inches,  $v$  is the striking velocity in f.s., and  $d$  is the calibre of the gun in inches.

Penetration of Tank Armour by 18-pr.

Range yards.	Thickness of Armour Penetrated inches.	Weight of 10 square yards of Armour tons.
1,000	2-331	3-902
2,000	1-914	3-204
3,000	1-633	2-798
4,000	1-520	2-544
5,000	1-409	2-369
6,000	1-323	2-215

The effect of armour-piercing shell, fired from high-velocity guns, in penetrating armoured turrets and cupolas, is given by the same formula. As an example, a 30-5-cm. (12-in.) gun may be expected to pierce the following thickness of hard-faced armour:—

Range, yards.	5,000	10,000	15,000	20,000	25,000
Penetration, inches	12-5	9-25	7-5	7-25	7

At 6,000 metres the 240-mm. gun penetrates 180 mm., and the 155-mm. G.P.F. gun penetrates 77 mm.

The cupola must be massive as well as stout, or else the effect of the blow will be to displace it and jam the rotating machinery, even if the shell does not penetrate. In the Liège and Antwerp cupolas, which were intended to resist 6-in. guns, lead cushions were used to reduce the "racking" effect. A small cupola of three metres in diameter cannot be expected to stand blows from heavy shell, though it may be stout enough to resist penetration. The striking energy of a 12-in. shell at 5,000 yd. is about 20,000 foot-ton.

At the beginning of the war, a fort was at a disadvantage in that its position was known, whereas it was fired on by long-range guns which could not be located, unless the aircraft of the defence retained the mastery of the air. The development of sound-ranging helps the defence in this respect, provided that the instruments can be set up in several forts connected by telephone.

### VII. EFFECTS OF COLLECTIVE ARTILLERY FIRE

These vary so much according to local and tactical considerations that no exact rules can be laid down. However, the following were rough working rules established during the war:—

**Standing Barrage.**—To keep down the fire of riflemen in a trench, each man should be liable to be killed if he shows himself above the parapet at least once a minute; therefore one shrapnel per minute should be burst in front of him. Taking the effective spread of shrapnel bullets at 25 yd., then 4 rounds per 100 yd. of trench are required. This is an "ordinary" barrage, and may be changed to a "heavy" barrage of 8 rounds a minute or a "light" barrage of 2 rounds a minute per 100 yd. as required. If a 4-gun battery has to barrage a trench of 300-yd. front, then at the "ordinary" rate each gun will fire 3 rounds a minute, distributed over the 75 yd. allotted to it. To barrage a communication trench "end on," 2 rounds a minute per 100 yd. of length are sufficient, when the line has been corrected to bring every burst over the trench. It is not necessary to barrage the whole length of a communication trench, which may be 2 m. long; aeroplane photographs show the most effective barrage points, namely the "defiles" at which there is no way round. Communication trenches may be so effectively barraged as to oblige the enemy to risk the chance of coming and going across the open.

**Creeping Barrage.**—This may be of several different kinds, as described above. With time shrapnel, or a mixture of H. E. and smoke shell, fired from field guns, a battery can efficiently barrage a front equal to its own normal front, or 20 yd. per gun. (The French reckon 15 metres per gun.)

In the British service the normal barrage rate was 4 rounds per field gun per minute for 2 minutes, then "lift" to the next range and repeat, and so on. On emergency a battery can cover a wider front for short periods; the comparatively slow rate of fire is due to the constant changes in elevation and setting of fuse, and possibly, in direction as well. However, this rate amounts to 240 rounds an hour per gun, which is about as much as a battery can do.

The French reckoned 2 rounds per 15 metres of front per minute for a "heavy" barrage, down to the same per 45 metres of front for a "light" barrage. The Germans, in 1918, advanced their barrage by "bounds" of 200 metres for field guns and 400 for medium guns and howitzers; after each bound the guns continued to fire at the same range ("pounding") for some minutes. Owing possibly to worn guns, the German barrage was considered less dense and less effective than that of the Allies, although the nominal rate of fire was higher.

When firing a barrage with time shrapnel, the bursts must be kept low, and a setting of fuse giving 50% of bursts on graze is considered the best. With H. E. shell instantaneous fuzes are best, unless there are no smoke shell in the barrage; in this case it may be better to use normal fuzes, in order to throw up more dirt and make a more opaque screen.

**Bombardment.**—It is found that a field H. E. shell displaces 4 cub. metres of earth per kg. of burster, or 2½ cub. yd. per pound.

\* A tank armoured in front only may require some 10 sq. yd. of armour.

With larger calibres the effect increases in a somewhat higher ratio. But the number of rounds required for a given task cannot be ascertained directly from these premises, since much of the effect of subsequent shell falling in or near the same place as the first shell is wasted by displacing the earth already lifted, which has fallen back into the crater. A more reliable guide is the diameter of the crater, which varies according to the soil. In ordinary ground a 6-in. howitzer mine shell, containing some 13 lbs. of H. E. makes a cylindrical crater about 4 yd. wide and 3 yd. deep, of which depth about one-third is filled up by earth falling back into it. Hence to destroy a 12-ft. parapet it must be struck by one 6-in. shell per 4 yd. of front. If a calibre be employed which gives a crater of less diameter than the thickness of the parapet, this will entail a great waste of ammunition. Thus the French found that under practice conditions of accuracy it took 11 rounds of field-gun shell per yard to breach a parapet 10 ft. thick, or perhaps 20 rounds a yard under war conditions. Therefore they consider that for practical purposes a 10-ft. parapet is proof against field guns and 4-2-in. field howitzers.

At stout brick and concrete walls, H. E. shell with "normal" fuzes (i. e. neither instantaneous nor delay action) are very effective. A wall 20 in. thick is cut down by an expenditure of two or three field gun shell per yard. A field-gun shrapnel will pierce a wall of this thickness at medium range.

At field guns in the open, the French reckon 15 rounds of field-gun shell at 3,000 metres, or 25 rounds at 3,500 metres, to make a hit on a gun. The British 18-pr., under experimental conditions, is capable of making 60% of hits on a gun in action at 2,000 yd., 16% at 3,000 yd., and 5% at 4,000 yards. Medium guns such as the 60-pr. or French 4-2-in. maintain their accuracy to longer ranges than field guns; a rough rule is to add one-third to the field-gun range for the same percentage of hits; thus a 60-pr. is capable of making 16% of hits on a gun at 4,000 yards.

The following experimental results (Krupp) show the comparative effects of various natures of field-gun and field-howitzer shell fired at a battery of four guns in action, a wagon beside each gun:—

(a) H. E. field-gun shell, percussion fuze. Range 5,000 metres. One hundred rounds disabled 1 gun, 1 wagon, and 11 dummy men out of 34.

(b) The same, time fuze. One wagon damaged, 4 dummies put out of action.

(c) The same target, range 2,000 metres, fired at 4-2-in. howitzer (presumably similar to the German service field howitzer). Time shrapnel. Twenty-four rounds fired after ranging had been completed with 11 rounds percussion. Result, 26 dummies put out of action out of 34.

A heavy discount must be taken of these experimental results for war conditions, especially in view of the quality of war-time fuzes. However, the general inference is that percussion H. E. shell is a much better projectile to fire at a battery in the open than time H. E. shell, and that field-howitzer time shrapnel is remarkably effective when the range and fuze can be correctly found, though it probably takes much longer to produce effect with it than with H. E. shell. In duels between field batteries, such as often unexpectedly occurred during the war, it is all-important to knock out the enemy's guns as quickly as possible, and percussion H. E. shell with instantaneous fuze is the best projectile to use.

**Wire Cutting.**—The development, during the war, of the methods of cutting barbed wire by the fire of artillery has already been described. With the British 18-pr. at ranges of 600 to 1,800 yd., a belt of ordinary barbed wire entanglement 8 yd. deep can be cut through with an expenditure of about 10 yd. of time shrapnel per yard of front. The process is slow, as very precise shooting is required. A better projectile is 4-5-in. howitzer H. E. shell with instantaneous fuze; each effective round, at ranges up to 6,000 yd., clears a circle about 3 yd. in diameter. Howitzer H. E. shell with normal or delay-action fuze makes a crater into which the network of wire falls back, and so makes a worse obstacle than before. A 5½ lb. trench mortar bomb with instantaneous fuze clears a circle 5 yd. in diameter. The French in 1918 used field guns firing H. E. shell, either with instantaneous fuzes or with a slight delay action to burst the shell on ricochet. The lines of fire were 5 metres apart at the target. At a belt of strong wire 25 metres deep it was found that 600 rounds were required to clear a lane 25 metres wide. The ranges were from 2,000 to 4,000 metres. Tanks, when available, are much better wire-destroyers than artillery.

**Fire with Star Shell.**—These are used for illumination, and are usually fired from field howitzers. They must be burst at such a height that the stars burn out before reaching the ground; otherwise they form a smoke screen on the ground, besides setting fire to dry vegetation. A star shell, properly burst, lights up a circle about 50 yd. in diameter effectively, and patrols are distinguishable up to about 100 yards. For continuous illumination, four shell per minute per 100 yd. of front gives good results. (See also, generally, the article ORDNANCE.) (H. A. B.)

**ARTOIS, BATTLES IN (1914-7),** see Plates I., II., III. and IV.—(A) FIRST BATTLE OF ARRAS (SEPT. 30-OCT. 8 1914).—After the stabilization of the battle-front on the Aisne and to the E. of it, about Sept. 16, both the Allied and the German Higher Commands



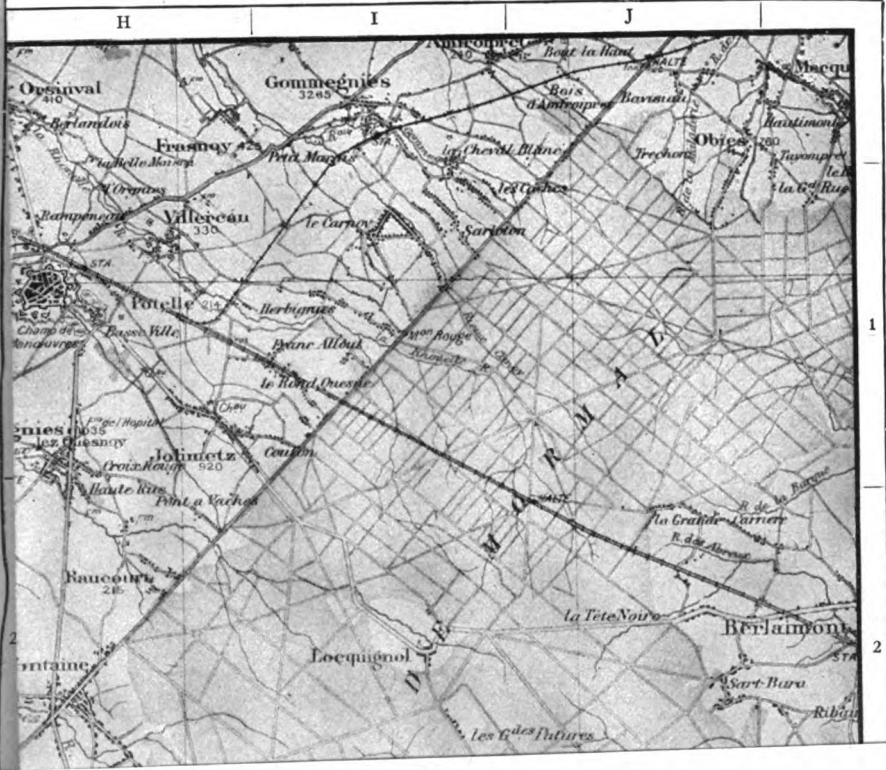



proceeded to despatch forces to their northern flanks, with the object of outflanking the hostile battle line. There thus ensued what is known as "the Race to the Sea," which ended about the middle of Oct. in the establishment of a continuous front from the Belgian coast to Switzerland. On this front, after a series of furious battles which raged until well into Nov., both sides settled down to trench warfare on the advent of winter.

The first attempt to outflank the German right N. of the Oise was entrusted to the French Second Army, under Gen. de Castelnau, which was transferred from Lorraine from Sept. 20 onwards. This army, consisting of the XIII., IV., XIV., XX., and XI. Corps, was eventually opposed by the German IX. Reserve, II., XVIII., XXI., I. Bav., II. Bav. and XIV. Reserve Corps, brought up from various parts of the line, and after heavy fighting, in which first one side and then the other held temporary and local advantages which proved impossible of exploitation, these forces were left facing each other on the general line Lassigny-Roye-Chaulnes-Albert-Hebusme, on which they finally fortified themselves. The battle on the front of the French Second Army died down in this fashion about the middle of October. Before this date the further prosecution of the mutual attempt at envelopment by both sides had brought about an extension of the fighting to the neighbourhood of Arras and Lens.

*Battle of the Tenth French Army around Arras, Sept. 20-Oct. 20.*—The front of the Second Army was prolonged to the N. by the group of Territorial Divisions (the 81st, 82nd, 84th and 88th) under Brugère, which had been ordered on Sept. 29 to push forward detachments to cover the detrainment of reinforcements at Arras and Lens, and by the 1st Cavalry Corps (Conneau) (1st, 3rd, 5th and 10th Cavalry Divisions) which was holding the line of the Cojeul on the left of the territorials. On Sept. 30 Gen. de Maud'huy was given command of a "Detachment of the Second Army," consisting of the X. Corps, two divisions (the 70th and 77th) formed into a Provisional Corps under D'Urbal, and the 1st Cavalry Corps; his orders were to concentrate in the region of Arras and to act against the right flank of the German corps facing the Second Army. It was believed that this flank would be found about Bapaume. Of the forces at Maud'huy's disposal the X. Corps was on this date marching from Amiens in the direction of Arras, being still some two days' march from the latter place, while the divisions of the Provisional Corps were commencing to detrain at Arras, covered by the 1st Cavalry Corps in the line of the Cojeul and a mixed Territorial detachment at Douai.

The situation of the enemy on the front of the detachment, somewhat obscure on Sept. 30, became clearer on the following days. Strong hostile forces (the IV. German Corps) were reported as moving N. and halting for the night in the neighbourhood of Quéant, with the evident intention of falling on the flank of the Second Army, at this time around Courcelles. The advanced guards of these columns had got into contact with the French cavalry on the line of the Sensée. Further to the N. other German troops (the I. Bavarian Reserve Corps) had driven the advanced troops of the Territorial detachment back to Douai.

Despite the fact that the battle showed as yet no signs of dying on the Second Army front, that the enemy were pressing hard against his centre, and that a shortage of munitions was beginning to make itself felt, Gen. de Castelnau adhered to his original intention of enveloping the hostile left with the detachment under Maud'huy on Oct. 2, and orders to this effect were sent to the latter on that evening; Maud'huy had already made his preparatory dispositions. The X. Corps was to be assembled around Fичеux, the divisions of the provisional corps N. of Neuville Vitasse and at Gavrelle, the Cavalry Corps N. of Monchy-le-Preux; all were to be in position by 6 A.M. The X. Corps and the 77th Division and the main body of the cavalry were to be ready to advance south-eastwards next morning against the flank of the enemy around Quéant, while the 70th Div. at Gavrelle was in a position either to cooperate in this advance or to deal with any hostile forces advancing by Douai.

In continuance of these instructions, the X. Corps was directed early next morning to move eastwards to Mercatel, whence it was to advance against the line Ervillers-St. Leger, and thence in the general direction of Mory, as soon as orders were received from Gen. Maud'huy.

Before, however, the X. Corps had reached its area of concentration around Mercatel the 77th Div. on its left was assailed from the E. by newly arrived German troops (the IV. Corps), who forced it back from the Cojeul to the line Guemapphe-Monchy-le-Preux, while at the same time the I. Bavarian Reserve Corps, which had entered Douai on the evening of the 21st, was pushing its advance westwards to the north of the Scarpe—an advance which the 70th Div., delayed in its march from Lens, where it had detrained, to Gavrelle, was not yet available to oppose; the X. Corps was therefore ordered to change the direction of its proposed advance from S.E. to N.E., and assigned as its new line of attack the course of the Cojeul and as its objective the crest N. of Croisilles and W. of Hezainel. The Corps would thus strike in flank the enemy advancing S. of the Scarpe, who by 2 P.M. had taken Monchy-le-Preux and driven back the 77th Div. to the Enc Neuville Vitasse-Feachy Chapel. Meanwhile the 70th Div. on the N. bank of the Scarpe, advancing towards Gavrelle, had been held up and thrown on the defensive on the front Rouvroy-Ezel-Bailleul, so that between it and the 70th Div. to the S. there existed a wide gap, which the 1st Cavalry Corps was urgently ordered to fill to the best of its ability.

Owing to the change of direction which had been ordered the attack of the X. Corps was not delivered till the late afternoon, and made little headway against the IV. German Corps, so that at the end of the day a further gap in the French line was formed between the left of the X. Corps and the right of the 77th Div., which had to be filled by troops from the general reserve. Gen. de Maud'huy, despite the disappointment of the day, ordered that the X. Corps should be prepared to resume its attack next morning, the 3rd on the N. bank of the Cojeul in the direction of Monchy-le-Preux, while the remainder of the detachment was to maintain its positions of the previous day. The X. Corps, however, met with no better fortune on this day; the Germans maintained themselves in Neuville Vitasse after heavy to-and-fro fighting, and the retirement of the Territorial troops to the S., who were forced out of Courcelles by the attacks of the German Guard Corps, compelled the X. Corps to throw back its right in conformity, under severe enemy pressure, as far as the line Fичеux-Mercatel. Both the 77th and 70th Divs., however, succeeded in repelling all the violent efforts of the enemy; the gap between these two divisions in the Scarpe valley was successfully closed by Conneau's 1st Cavalry Corps; and reinforcements consisting of the XXI. Corps (Maistre), detraining at Armentières, Merville and St. Pol, and the 2nd Cavalry Corps (4th and 5th Cavalry Div.) under De Miftry, then holding the front Benifontaine-Lens, were placed at the disposal of De Maud'huy. These forces were increased by the 49th Div. detraining at Arras, which was assigned to D'Urbal's corps.

On the front of this corps fighting continued throughout the night, and the 70th Div. was forced to withdraw some three miles westwards to the line Vimy-Farbus-Bailleul, along the eastern slopes of the Vimy ridge. This retirement uncovered Lens, which fell into German hands early on the 4th. The situation of the detachment, which now found both its flanks in the air, was by no means an easy one; Maud'huy's orders for the 4th, however, were that the positions then occupied were to be held at all costs. The X. Corps was to maintain itself on the line Tilloy-Beaurains-Mercatel, with its right flank thrown back if necessary to Fичеux, and to reestablish the connexion with the left of the Second Army which had been lost owing to the retreat of the Territorials. D'Urbal's corps was to hold its ground on the front Vimy-Bailleul-Athies-Feachy Chapel, so as to allow time for the XXI. Corps to advance by La Bassée against the flank of the I. Bavarian Reserve Corps, which was attacking N. of the Scarpe. The 1st Cavalry Corps was to



secure the left of D'Urbal around Givenchy-en-Gohelle. One brigade of the 43rd Div. which had already been despatched to Arras was sent forward to reinforce the Provisional Corps, and the second was detained at Beaumetz and passed on to Duisans in general reserve.

The German attacks continued without cessation throughout the 5th.

Prince Rupprecht of Bavaria, commanding the Sixth German Army, arrived at Douai and took command of the whole battle front between the Somme and the Lys. On the French side Gen. Foch was entrusted with the coordination of the front N. of the Oise, and with the general control of the Second Army, the Territorial group, the 1st and 2nd Cavalry Corps and Maud'huy's command, which now became the Tenth Army; Foch moved his headquarters to Doullens on the 5th, Maud'huy's remaining at Aubigny.

During the greater part of the day the Tenth Army successfully held its ground, but in the evening its left was forced to retire still further W. by the vigorous attacks of the I. Bavarian Reserve Corps, to the N. of which the 2nd German Cavalry Corps of von der Marwitz was now coming into action. Givenchy fell into the hands of the Bavarians, and while their right advanced beyond it to Souchez their centre assaulted and carried the Vimy ridge as far S. as Thelus; the French cavalry were driven back to Villers au Bois and Mont St. Eloi, while the 70th Div., reinforced by all available troops of the 45th Div., again made head against the enemy on the line Carency-Neuville St. Vaast-Rochincourt-Athies. This was the situation reported to Gen. Maud'huy on the morning of the 5th; and shortly after this bad news had been received the X. Corps announced that its right had been forced back from Boislez, where it had maintained itself throughout the previous day, to Fischeux; that hostile columns were reported moving round its flank by Blaireville; and that the stations of Beaumetz and Saulty on the Arras-Doullens railway were being bombarded.

This was about 10 A.M., and in view of the extreme gravity of the situation on both its flanks Gen. Maud'huy was already taking preparatory measures for the evacuation of Arras and for a withdrawal in the direction of St. Pol, should such become necessary as a result of further progress by the enemy, when Gen. Foch arrived at his headquarters and it was decided to make another effort to restore the position. The Germans had not pressed their advantage against the left of the army to the extent that had at first been feared; the Cavalry Corps was therefore ordered to advance against the right, which had pushed no farther forward than Souchez, and disengage the left of the 77th Division. D'Urbal's corps, which was about to fall back to the line Mont St. Eloi-Etran-Waslué (W. of Arras), was directed to maintain its ground with its right and centre and cooperate with its left in the attack by the cavalry. Meanwhile reconnaissances had revealed the fact that neither the German IV. Corps nor the Guard had yet taken advantage of the gap between the X. Corps on the right of the Tenth Army and the Territorials on the left of the Second Army; the former was therefore instructed to maintain its line and echelon troops in rear of its right between Fischeux and Gouy. Accordingly on the evening of the 5th the X. Corps had established itself firmly on the front Beaurains-Riviere. The attacks of the Cavalry Corps and the 70th Div. however, made no headway, and their line was established at the end of the day at the western foot of the Vimy ridge on the front E. of Mont St. Eloi-S. of Neuville St. Vaast-Ecurey-Rochincourt-St. Laurent. Further S. the line was continued by the 77th Div., which had been drawn back in conformity with the retirement of the formations on both its flanks to the second position prepared in rear, between Blangy and Tilloy.

The orders for the 76th were for a renewal of the attack on the left wing of the Tenth Army; it was to be carried out by the 43rd Div. (of the XXI. Corps) which was assembling W. of Carency, the 1st and 2nd Cavalry Corps which were to advance between Souchez and Liévin, and the XXI. Corps (less the 43rd Division) which was to envelop the enemy's right advancing

by La Bassée and Dem. on Vimy. Various untoward circumstances combined to thwart the execution of this plan. The attack of the Cavalry Corps began late and with insufficient forces, could make little impression on the strong front held by the enemy between Notre Dame de Lorette and Angres, and the 43rd Div. to the S. of it was also held up, while the enveloping attack of the XXI. Corps from La Bassée failed to develop. Elsewhere on the front the German attacks were repulsed, and by the evening the army held the line Beaumetz-Arras (X. Corps), Arras-W. of Neuville St. Vaast (Provisional Corps)-Carency-Aix-Neulette (43rd Div. and Cavalry Corps)-S.E. of Greny-Looz (XXI. Corps) with cavalry towards Font à Vendin and Carvin. Arras was being shelled by the enemy.

According to army orders the XXI. Corps commenced its attack early on the 7th against the enemy reported to be on the line Angres-Liévin-Lens, while the cavalry and the 43rd Div. continued their endeavours to press forward towards Notre Dame de Lorette and Souchez. The Germans, however, had strengthened their positions during the night, and little progress could be made. Moreover, it had become evident that the battle line must be extended yet further to the N. in order to meet a renewed German attempt to envelop the French left by the valley of the Lys. Accordingly the 1st and 2nd Cavalry Corps were withdrawn from the battle-front in the late afternoon preparatory to their despatch to the N., the 13th Div., then in the vicinity of Lille, being ordered S. to take their place in the Tenth Army. On the rest of that army's front the situation underwent no important change during the 7th.

From this date forward the fighting at Arras died gradually away. Renewed efforts by the XXI. Corps on the 8th and 9th ended in the recovery of Notre Dame de Lorette. On Oct. 20 further fighting E. of Arras resulted in an advance by the 10th Corps, and on the 22nd the 77th Div. was forced back N.E. of Arras by strong enemy forces, who were compelled next day to relinquish part of their gains.

These were but the dying flickers of the fire of battle which had long since shifted its main focus to the north.

*Extension of the Battle to the Lys Valley, Oct. 9-12.*—While the battle of Arras was still at its crisis, the German right wing was already being extended further to the N. into Flanders. On Oct. 3 a mixed detachment of Landwehr entered Tournai; the 4th Cavalry Corps (3rd, 6th and Bavarian Cavalry Divs.) had come into line on the right of the 1st Cavalry Corps, which was then engaged with the French and Cavalry Corps, with its right S. of La Bassée. The right of these fresh forces advanced on Lille, from Tournai and Orchies, while its left advanced from Douai on La Bassée; by the 4th contact had been made with the French in the western outskirts of Lille.

To meet this new threat the French Higher Command had moved up the 2nd Cavalry Corps (4th, 5th and 6th Cavalry Divs.) under De Mitry to the area between Lens and Lille, and had garrisoned the latter city with the 13th Div. (of the XXI. Corps) which had detrained at Armentières, covered by the 7th Cavalry Division. The first attacks of the German cavalry on the city were beaten off and the suburbs cleared; but, as has already been related, the 13th Div. was then called away to the S. to rejoin its corps, and left behind it only a weak detachment of six battalions and four squadrons to hold the city, and of these two further battalions were withdrawn on the 8th. Meanwhile to the S. between Lens and the Béthune-La Bassée canal the XIV. German Corps had come into line, forcing back the French cavalry to the W. of the Lens-La Bassée road to the Vermelles-Cambain; on this line heavy and continuous fighting took place from Oct. 20 onwards, where the position gradually became stable.

Further to the N. the German cavalry continued their advance, extending their right as far as and beyond the Lys and covering the whole country from La Bassée by Lille, Tourcoing and Wervicq to Ypres. The centre and left of De Mitry's cavalry fell back before them, pivoting back on their right from Neuve Chapelle by Estaires and Merville to Hazebrouck and Cassel; this line was reached about Oct. 9. The main body of the German

cavalry appeared to be assembled around Bailleul and Steenvoorde, while behind it strong forces of infantry were advancing, the XIII. Corps to the S. and the XIX. to the N. of Lille. The garrison of the city, although reinforced on the 10th by a detachment, were unable to make head against these overwhelming forces, more especially as the presence of the German cavalry in all the area to the W. deprived it of all hope of succour; and after two days' bombardment Lille surrendered to the enemy with its garrison on Oct. 12.

The battle, however, was now about to enter on a new phase with the entry into action of the British army.

*Operations of the British in the Lys Valley, Oct. 10-18.*—The transfer of the British from the Aisne to the left flank of the French army in Flanders had first been proposed by Sir John French on Sept. 29; the details were quickly arranged between him and Joffre, and the withdrawal from the line commenced on Oct. 1. The cavalry moved off first by road on the 2nd, and were followed by the infantry between the 8th and 12th. Sir John French, on his arrival at Abbeville on the 8th, had planned a general advance by the II. Corps, then detaching there, to the line Aire-Béthune, covered in front and to the left by the Cavalry Corps, and the detaching of the III. Corps to the N. at St. Omer. The IV. Corps and the 3rd Cavalry Div., under Gen. Rawlinson, which had been landed on the Belgian coast in order to assist the Belgians in the defence of Antwerp and had assisted in covering their retirement to the line of the Yser, had been holding the line of the Lys around Ghent on the 11th, and were instructed to maintain themselves between that town and Courtrai for four or five days, if possible; it was intended to bring the rest of the army up on the right of the IV. Corps, so as to hold the Lys line from Ghent southwards. Rawlinson was authorized, however, in case he was attacked by strong hostile forces, to fall back in the direction of St. Omer, and as a matter of fact the retreat of the Belgians to the N. of him eventually necessitated his retirement by way of Thielt and Thourout to Roulers, where the IV. Corps arrived on Oct. 12, unmolested by the enemy.

On the 10th French visited Foch, and a plan for a combined Allied offensive for the 13th, to reach the line of the Lys from Lille-Courtrai, was then drawn up. The British were to advance, with their right N. of Lille, to force the river Lys at Courtrai and join up with Rawlinson's IV. Corps below that town. The Belgians were also to cooperate in the north. In accordance with this plan, the British cavalry pushing forward on the 11th came into contact with the German IV. Cavalry Corps, operating before the right wing of the VI. Army, in the neighbourhood of Nieppe forest, and forced them back towards the Lys; the II. British Corps reached the line of the Aire-Béthune canal. By the 14th the cavalry had cleared the country to the E. as far as the Wytchaete-Messines ridge and pushed patrols forward to the crossings of the Lys; but the II. Corps, wheeling up its left in the direction of Merville, became heavily engaged with German infantry (the XIII. and XIX. Corps of the VI. Army), which prevented their making much headway. The III. British Corps, having completed its movement to Hazebrouck by the 13th, began its advance eastwards, to bring it level with the left of the II. Corps. This objective, however, was not attained without serious and sustained fighting; the Germans (XIX. Corps and IV. Cavalry Corps) stubbornly defended Bailleul, Meteren, Neuve Eglise, Saily and Nieppe one after the other; by the 16th, however, the British were in possession of all these places. The II. Corps also had worked their way forward by dint of determined efforts to the line Aubers-Givenchy, and came into touch with the XXI. Corps on the left of the French X. Army, on the Béthune-La Bassée canal.

While the II. Corps, despite determined and unceasing attacks, found further progress impossible beyond the line Givenchy-Festubert-N. of Aubers, which it reached on Oct. 18, the III. Corps entered Bois Grenier and Armentières, and was able to establish itself on a line E. of these places, while the Cavalry Corps, guarding their left, continued the line along the Lys to Menin. By the morrow the assembly of the British army in the

N. was completed by the arrival of the I. Corps at Poperinghe, St. Omer and Cassel. The battle of the Lys now became merged in the greater battle of Ypres, in which the whole British force was engaged from Oct. 20 to Nov. 20, and the description of the fighting between these dates on the front of the British II. and III. Corps will be found under that head. It may be said, however, that neither the British nor the Germans, despite their utmost efforts, succeeded in bringing about any material change in the situation on the front between the Béthune-La Bassée canal about Givenchy and the Lys to the N. of Armentières.

(B) *FRENCH OFFENSIVES IN ARTOIS, 1915.*—During the month of Oct. 1914 the western front had stabilized across Picardy and Artois, from the Oise to the neighbourhood of La Bassée. The line had not been chosen at the will of either party, but marked the points which each side had reached and held during the confused and rapid series of actions known as the "Race to the Sea." While there was still open country to the north it had been worth no one's while to attempt to dislodge an enemy present in any force. And when the sea had been reached and the German attacks upon the Yser repulsed, neither side retained the energy to advance. Both, therefore, had time to elaborate their defences in comparative peace, and thereby the sinuous and haphazard line already established became permanent.

About Arras the line bulged eastward, leaving Beaurains German but making St. Laurent-Blangy, Roclicourt, and Ecurie French. To the north was a westward bulge which gave the Germans Neuville-St. Vaast and La Targette, Carency and Ablain, Angres, Liévin, and La Fosse Calonne. North of Fosse Calonne the line ran straighter to the west of Loos, Hulluch, Haisnes, and La Bassée.

Artois is a chalk country. The surface soil is clay, with patches of sand unsuitable for cultivation and therefore wooded. The principal natural feature of the region is a long isolated ridge running from N.W. to S.E., which overlooks all the countryside. This ridge culminates at the chapel of Notre Dame de Lorette. East of the chapel there is a gap marked by the village of Souchez. East of Souchez again, the ridge continues as Vimy ridge and gradually dies away south of Vimy village.

The sector was of first-rate importance both for economic and for strategic reasons. North of the ridge ran the principal French and Belgian coal seams the axis of which in Artois is roughly the line Béthune-Lens. Although the public mind was naturally slow to grasp the fact, nevertheless as soon as it became clear that trench warfare would result in the postponement of a decision, first-class economic objectives, such as the coal-mines, began to increase in general military value and continued to do so until the decisive campaign of 1918.

Strategically, the German lines in Artois covered the Lille-Douai-Cambrai railway, their main transversal line behind all this part of their front. Should this line be cut, were it even brought under effective artillery fire, their railway traffic would be compelled to use the inferior line Lille-Orchies-Somain-Cambrai.

Although the final elaboration of trench warfare was a matter of years, its general characteristics, especially the strain and hardship of remaining immobile and in close contact with the enemy, appeared at once. The possibility of manoeuvre disappeared and war became an affair of ever-increasing masses of material. In Artois, the importance of the sector and the nature of the soil made the fighting fierce and continuous and the hardships peculiarly bitter. The clay soil churned into a soft and sticky mud into which men sank deeply and sometimes even were lost. Everywhere the ground was humid; the Lorette ridge itself was honeycombed with springs so that trenches dug even on its summit were difficult to keep clear of water. Weapons often became unserviceable, and the men themselves looked like walking lumps of mud. Nevertheless, the fighting was not only savage but continuous. A major operation was merely a crescendo in a never-ending series of furious lesser combats, all centring about the commanding Lorette-Vimy ridges.

Throughout the first three years of trench fighting on the western front, in most of the minor operations, and in every

major operation except Verdun, the Allies attacked. Save in that one case, the Germans held to their decision to stand upon the strategic defensive in France and Belgium, from Nov. 1914 to March 1918. In order to attempt a decision, it was, therefore, necessary to attack their entrenchments. The strength of the defensive in trench warfare, and the corresponding difficulty of the attack, were realized only with time.

Originally, the entire Lorette ridge was occupied by the Germans during the race to the sea; the French swept them off in a brilliant little attack. Then the Germans moved in again and took the chapel and all the eastern end of the ridge nearly to the wood of Buigny, not by assault but because the place had been left entirely unguarded during the night of Oct. 7-8 in the course of a relief of the French troops in the sector—an incident altogether typical of the race to the sea. As regular trench warfare began, the Germans had the best of the artillery fighting. Their guns were both heavier and more numerous, and their fire control better suited to the new and unexpected sort of fighting. Their batteries were emplaced near Lévain and Angres, behind Vimy ridge, and behind the butte of Monchy-le-Preux. In Nov. they began to use hand grenades, the first of the typical trench weapons to appear, or rather to reappear. The French did not begin manufacturing grenades during the following winter, and were not able to issue them to the troops until March 1915. Nevertheless, despite the German heavy artillery and grenades, the month of Nov. saw such an improvement in the French defensive works that casualties became fewer, although it was not yet possible to put out continuous wire.

Early in Dec. the situation changed for the better with the arrival of several units of French heavy artillery, whose fire compelled the Germans on Lorette ridge to take cover in their deep dug-outs. The French Higher Command ordered the XXI. Corps, which had held the Lorette sector since its stabilization, to attack in the hope of a break-through. The Corps commander, Gen. Maistre, was doubtful of the success of the operation proposed, judging the means insufficient and the obstacles to be encountered too strong. Nevertheless, the attack took place on Dec. 17 at 1:10 p.m. on a front of a mile and a quarter, with divisions against Auchy-les-La Bassée, and Loos, and in front of St. Laurent-Blangy. Near Lorette the artillery preparation had not been sufficient to prevent the assaulting troops coming under heavy fire, especially from machine-guns, as they left the trenches. The German wire was strong and had been very little cut. Nevertheless, they struggled on through deep mud, and succeeded in taking some trenches. For four days the operation was persisted in. The artillery support was weak, partly because of the winding, irregular front line, partly through insufficient liaison with the infantry. Against such handicaps the infantry strove bravely but in vain. At last, after murderous losses which justified only too well Gen. Maistre's forebodings, the attack was broken off.

An unbroken series of minor operations took place throughout the winter and early spring. In the afternoon of Dec. 27 ten battalions of Chasseurs Alpins, commanded by Gen. Barbot, attacked the hamlet of La Targette, after two hours of artillery preparation. "No-man's-land" was here a quarter of a mile wide, quite flat and without cover save for a single sunken road. Hence losses were heavy and only half a mile of first-line trenches were taken.

As the winter went on, the sticky mud became even worse, and the heavy German trench-mortar projectiles added still more to the danger and discomfort of the trenches. On March 3, at dawn, after a short but violent preparation by heavy artillery and heavy trench mortars, an entire German division made a sudden attack along the crest of the ridge, and drove the French into Buigny wood. Two days of counter-attacks recovered most of the ground lost, and throughout March and April a series of local attacks and counter-attacks slightly improved the French position at a cost in casualties disproportionately large in comparison with the ground gained. The dead were not all Frenchmen. Already the German troops were beginning to call the ridge "Totenhügel," the Hill of Death.

In April the first French 58-mm. trench mortars, few in number, were put in service. The French had already begun the use of hand grenades in March.

About May 1 the French Higher Command decided upon a general attack, and chose Artois as its sector. It was desirable that something be done on the western front in the hope of relieving the pressure upon the Russians, on whose front the great blow was about to fall. The British agreed to support the operation by a diversion in Flanders.

From the original formation of the French "Group of armies of the North," Gen. Foch had been in command. This command he still retained, and his was the decision as to the length of front to be attacked. Even at this early stage of trench warfare, he saw clearly that to estimate the possible width of an assault according to the number of infantry available was nonsense. He therefore insisted upon calculating the front to be attacked according to the available quantity of heavy artillery, insisting that a clear superiority in heavy pieces was necessary over the full width of the operation proposed. On the western front as a whole, the Germans still disposed of superior numbers in this particular arm, so that it seemed impossible to obtain a sufficient superiority of fire over a front of much more than six miles. As a result of Foch's insistence the width of the attacking front was limited accordingly. The right of the proposed assault was fixed in the neighbourhood of Roelincourt, the left on the northern slopes of Lorette ridge. At this stage of the war it was still believed that a violent effort, even on so restricted a front, stood a fair chance of breaking through the opposing trench system and restoring a war of movement.

From May 4, the German Higher Command was convinced that a considerable attack was to be expected. Nevertheless, so high ran their hopes of victory in the east that even Falkenhayn, usually so chary of reinforcements for that theatre, drew yet another division thither from France.<sup>1</sup>

In Artois, the French order of battle was as follows: the left of the XVII. Corps was around Roelincourt. North of them stood the XX. Corps, its left facing La Targette and extending a little north of that village. North of the XX. came the XXXIII. Corps, commanded by Pétain, the future commander-in-chief of the French armies on the western front. His extreme left faced Ablain. North again of the XXXIII. Corps, astride the Lorette ridge and on to the Arras-Béthune high road, stood the XXI. Corps which, always under Maistre, had held the sector from the beginning. The XX. and the XXXIII. Corps had three divisions each, the other corps two. All four corps formed part of the X. Army, now commanded by D'Urbal, who had relieved Maud'huy, the original army commander, in March. Foch shifted his headquarters from Cassel to Frevent on the Doullens-St. Pol road in order to follow the operation more closely. The troops were in high spirits at the prospect of quitting the foul and muddy trenches, and in the hope of fighting in the open thenceforward.

Opposite them, the German defences were formidable; indeed the painstaking German national character is well adapted to the construction of elaborate works. Each of the solidly built French villages was a complicated little citadel. North of Ecurie a huge tangle of trenches formed a strong point, known as the Labyrinth, covering more than half a square mile. A series of works, known to the French as the "Ouvrages Blancs," ran in a concave line from a hummock in front of La Targette to the western end of Carency. On the Lorette ridge itself, the ground favoured the defence. The southern slopes were precipitous and were, moreover, cut by deep ravines which the French likened to the gorges in a melon rind. Of the five spurs between these ravines, the Germans held the easternmost three, their front line running from a point a thousand yards west of the spurs of the chapel, across the summit of the third spur, and so to the western end of Ablain—a curious position which only the great strength of the modern defensive made possible. To the

<sup>1</sup> Falkenhayn, *Die Oberste Heeresleitung*, p. 74. At this period, Falkenhayn says, the total German combatant strength in the western theatre was 1,900,000 against an Allied total of 2,450,000.



Reproduced by permission from the map of France on the scale of

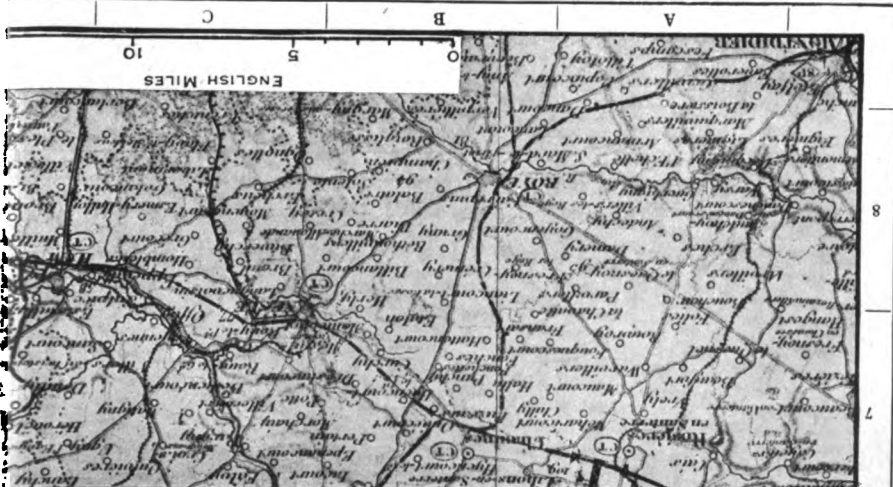

1  
2  
3  
4  
5  
6  
7  
8  
9  
10  
11  
12  
13  
14  
15  
16  
17  
18  
19  
20  
21  
22  
23  
24  
25  
26  
27  
28  
29  
30  
31  
32  
33  
34  
35  
36  
37  
38  
39  
40  
41  
42  
43  
44  
45  
46  
47  
48  
49  
50  
51  
52  
53  
54  
55  
56  
57  
58  
59  
60  
61  
62  
63  
64  
65  
66  
67  
68  
69  
70  
71  
72  
73  
74  
75  
76  
77  
78  
79  
80  
81  
82  
83  
84  
85  
86  
87  
88  
89  
90  
91  
92  
93  
94  
95  
96  
97  
98  
99  
100

north the ground fell away gently in an even slope broken only by the unexpected Buval ravine. The entire German part of the ridge was covered with trenches and obstacles and swept by batteries (at ranges of two to four thousand yards) around Liévin and Angres and behind Vimy ridge.

The troops which held these defences belonged to the German VI. Army which held the front from south of Ypres to within 10 m. of Arras. It comprised 26 divs., at a combat strength of about 17,000 per division according to the reduced German divisional organisation dating from the early winter of '14. This gave a little less than three men per yard of front considering the irregularities of the line. Crown Prince Rupprecht of Bavaria commanded the army, with Maj. Gen. Krafft von Dellmensingen for chief-of-staff, and headquarters at Lille.

The attack, originally ordered for May 7, was put off to the 8th and then to the 9th. Demolition fire was begun on the 7th and continued on the 8th, especially against the region of Neuville and the Labyrinth, but was hindered by the lack of all observation from the ground (no commanding points being in French hands), and by the serious imperfections of the aerial observation attempted by planes and dirigibles. The morning of the 9th dawned fair, with a light mist that soon cleared away. At six o'clock an intense bombardment was opened along the whole line from Loos to Arras, with heavy, divisional, and trench artillery. On the front of the XXI. Corps the 75's held their fire until eight o'clock, then began, and continued, at the rate of four shots per piece per minute. Amid the din of the bombardment, the French observers saw the German positions lost in vast clouds of smoke and dust sent up by the exploding shells. The German artillery replied energetically, searching for the French infantry assembled for the assault and occasionally hitting them with considerable effect. At 10 o'clock, precisely, the French artillery automatically increased the range and the infantry attack began.

The assaulting troops left their jumping-off trenches without signal. In a few moments it was clear that both wings were held up. The XVII. Corps could not gain a foot; the wire in front of them was still intact. The X. Corps, attempting a diversion east of Arras, uselessly lost 3,000 men in 10 minutes from machine-gun fire. North of the XVII., the right of the XX. Corps was helpless in front of the wire of the Labyrinth. The left of the XX. was doing better, the wire in front of them having been cut by the bombardment. In spite of heavy losses from German machine-guns still in position, they slowly cleared La Targette, fighting hand to hand, and by 11:30 they had advanced a little over half a mile and reached the westernmost houses of Neuville. On the ridge, the XXI. Corps was advancing only very slowly, at a cost of murderous losses. Their attack was peculiarly difficult to organize for want of a single conspicuous object in their front to serve as reference point for the artillery, and upon which the infantry could align their advance. Their assaulting elements came under heavy machine-gun fire as soon as they showed themselves, so that the communication trenches were obstructed by numbers of wounded who blocked the reserves. Machine-guns firing northward from Ablain made advance impossible along the southern slope. On the plateau itself and the northern slope, swept though they were at short ranges by the German batteries around Angres and Liévin, there was a slow and painful advance of about half a mile, which took three successive lines of trenches and reached, at noon, the neighbourhood of the chapel and the land N.W. of it. Through the morning, the extreme left of Pétain's Corps, the XXXIII., was fixed in front of Ablain. Other units, fighting every step of the way, were slowly working forward south of Carency.

Meanwhile, the right of the XXXIII. Corps had broken clear through the German line. Here, alone on the attacking front, the wooded hill of Berthonval had given good land observation by which to direct the bombardment. The wire had therefore been cleared and most of the machine-guns put out of action. Carrying conspicuous markers to enable the artillery to follow their march, the infantry swept forward

without a check. In the intoxication of such an advance after a winter in the abominable trenches, they got out of hand and ran forward, cheering as they rushed the German elements that tried to resist them. They crossed the Béchune road, gained the crest of Vimy ridge, and looked down upon the rolling plain to the north and east, towards Lens and Douai, with no more German troops before them. Hundreds of prisoners had been taken, it was only 11:30, and they had advanced over two and a half miles.

Naturally, the German command was frightened. Partially, at least, they had been surprised, for they had assembled no reserves. Twenty miles away, in Lille, the Prince of Bavaria's staff began packing up, for if the gap could be widened the whole front would go. But naturally, the assaulting troops were completely exhausted. They had run and yelled too much and their water-bottles had been emptied too quickly. During the advance, officer casualties had been numerous. About a mile of the crest between 110 and 120 was occupied, and patrols were pushed forward to Souchez and Givenchy.

Everything now depended upon the arrival of reinforcements. With them everything might be hoped; without them it would be hard to hold the ground already gained, limited as it was by concentric machine-gun fire from Souchez, Neuville, and La Folle wood; and no reinforcements came. The advance had been faster than had been planned, and either the army staff work was slow and the necessary orders not issued in time, or else the units ordered forward failed to make good speed. Perhaps, after all, the thing was impossible. Certainly no good road ran east into the newly created salient. At all events the opportunity was lost.

On the German side, when the first moment of panic had passed, the reaction was rapid. Great and deserved credit was won by the staffs concerned. During the afternoon, enough battalions from the second line of the division near by were scraped together for a counter-attack (supported by artillery behind La Folle wood) which retook the crest. The French-African troops, with most of their officers gone, failed to do themselves justice. All this time Neuville and Carency were holding out, and the XXI. Corps could not clear the Lorette plateau. Towards evening the cemetery south of Souchez had to be abandoned. Through the night, third-line battalions from the neighbouring German Army Corps began to come up. The French maintained themselves with difficulty at the Cabaret Rouge and along the road from Souchez to Neuville. The golden moment had passed.

During the next three days, the French improved their positions in vigorous local operations, taking the debris of Lorette chapel, Carency, and most of Neuville. By June 9 Ablain, the sugar-works west of Souchez, and the south-eastern slopes of Lorette were cleared. June saw the Labyrinth painfully occupied, and a narrow and difficult salient (including a bit of Vimy crest) first thrust out eastward from the Cabaret Rouge and then withdrawn. About the same time the Germans were pushed off the north-eastern slopes of Lorette—their last foothold on that murderous ridge now thickly covered with the dead of both sides.

The diversions attempted meanwhile by the British had failed to affect the general situation.

Tactically, the spring offensive in the Artois had partially succeeded. Twenty-five square miles had been gained, the enemy's local resistances had been beaten down, for some hours his front had been pierced. But strategically, the operation had failed. The German front had been very slightly modified and the Russians had been helped in no way.

During the summer, the usual round of little fights went on, barren of results but endured always with the same spirit. In Aug. trench knives were issued to the French infantry for the first time.

In the autumn, another Entente offensive on the western front was decided upon. The French prepared to attack in Champagne and both French and British in Artois, the French from Neuville to north of Souchez, which large village was,



by this time, laid almost level with the ground; the British from Haines to Loos—a far more ambitious effort than previous British trench-warfare operations. The main attack, however, was that in Champagne, Artois being only the scene of a diversion on a large scale.

The troops to be put in motion were Maistre's much-enduring XXII. Corps in front of Souchez, and on their right the XXXIII. Corps, now commanded by Fayolle, in front of La Folie. The French and German Higher Commands were the same, except that Maj. Gen. v. Kuhl was now chief-of-staff at Prince Rupprecht's headquarters.

Tactically, the operation was planned differently from that of May in that the attempt was made to crush the enemy by an intense bombardment prolonged throughout several days and that, therefore, no surprise could be hoped for. Objectives were to be strictly limited.

Accordingly on Sept. 20, with improved ground and air observation, and with guns and munitions available on a larger scale than ever before, there began a bombardment of the German works and rear areas, which continued day and night for five days. On the morning of the 25th the bombardment was intensified. At the same time the Germans began their counter-preparation and succeeded in inflicting some loss on the French infantry in their jumping-off trenches. The fine weather had turned to rain.

At 25 minutes past 12 the infantry attack began. The spirit of the German infantry had been broken by the bombardment so that there was little or no resistance, what little there was being due to imperfect "stopping-up." Meanwhile, the German barrage had been laid down too late, and afterwards ignorance of the situation made their artillery afraid to fire. On the other hand, the rain and the muddy, shell-torn ground made the advance very slow. Not until 5:30 in the evening of Sept. 26 were the ruins of Souchez completely cleared and the line carried a quarter-mile to the eastward.

Meantime, unknown to the French, the German command was passing through a crisis of anxiety. Their reserves had not yet come up and the positions on Vimy ridge were almost without defenders and trains were run at short intervals on the Douai-Mericoort-Rouvray line to simulate the arrival of reinforcements. But the bad weather, the abominable terrain, and the French policy of limited objectives saved the situation for the Germans. On the 27th their reserves arrived and the situation was re-established. The action continued, but although the 28th saw the French lines advanced to include an important redoubt in front of Givenchy, the German front was no longer in danger of being broken, and after the 28th the French broke off the battle.

Early in 1916, British troops relieved the French in the sector, which had seen the longest, and (after Verdun) the most murderous battle of the entire war. The French are said to have had in Artois no less than 100,000 killed. The XXII. Corps alone, by Dec. 1915, lost 80,000 dead or wounded, 18,000 of whom fell in the six weeks from May 9 to June 20. (H. N.)\*

(C) NEUVE CHAPELLE.—The objects with which Sir John French attacked the German lines in March 1915 were to obtain a more favourable position for his share in the major operations to be undertaken in conjunction with the French. The fighting of Oct. and Nov. 1914 had left the British right between the La Bassée canal and Armentières in an indifferent position tactically. After gaining a foothold on the ridge which runs S.W. from Lille past Aubets they had been thrust off it into the more or less waterlogged low ground at its foot. To recover this ridge was essential if the German hold on the Lille-La Bassée line was to be effectively shaken and Sir John hoped, moreover, to stimulate his troops whose offensive spirit had found few

outlets in the cramped conditions of trench warfare in a twimp. The point he selected for his attack was on the front held by Sir Douglas Haig's I. Army, where the Germans' capture of the village of Neuve Chapelle (Oct. 27 1914) had driven a salient into the British lines. This portion of the British front had always been particularly difficult and costly to hold and a substantial success here might not only gain a footing on the Aubers ridge but render the German positions opposite Givenchy and Festubert untenable.

The attack delivered on March 10 by the 8th Div. (IV. Corps) on the left and the Meerut Div. (Indian Corps) on the right was successful in effecting a surprise. There had been no long preliminary bombardment to give warning of the attack, for the ammunition supply only sufficed for 35 minutes' shelling, and the infantry, finding the wire well cut except at the extreme ends of the line, stormed the positions with ease. The 25th Bde. of the 8th Div. carried Neuve Chapelle village and joined hands with the Gahrwal Bde., who had overrun the ground between the village and the cross-roads S. of it known as "Port Arthur." Many prisoners were taken, and it seemed that reinforcements had only to push on to achieve a substantial advance. Unfortunately, the stubborn resistance of the Germans at the ends of the line absorbed the attention of the troops in immediate support. On the left, S. of the ruined farm known as "the Moated Grange," the 2nd Middlesex were held up by wire, which a fold of the ground had concealed from the artillery-observing officers; on the right at Port Arthur a strong point held out for several hours, and was only carried when the 2nd Seaforths of the Dehra Dun Bde. reinforced the original assailants of the Gahrwal Brigade. Similarly, it was not till well past midday, and after heavy fighting, that the 23rd Bde., improving the lodgment made by their right battalion, the 2nd Scottish Rifles, secured their second objective, and then only by utilizing two battalions of the 24th Bde. as well as their own supports, the 2nd Devons and 2nd West Yorkshires. Meanwhile the 25th Bde. had cleared Neuve Chapelle but found their left too much exposed to allow any advance beyond the village. More important still, the orders had been explicit that the reserves were not to be put in without sanction from the Corps, and the extreme difficulty of maintaining communications with the advanced troops prevented divisional and corps headquarters from keeping in touch with the progress of the attack and delayed the advance of the reserves. Not till the afternoon was well advanced did the leading troops of the 9th Div. pass through the 8th, and though the 21st Bde. then cleared a substantial area N. of Neuve Chapelle and made some progress down the German trenches beyond the Moated Grange, German reinforcements both of men and guns made their presence felt, and darkness stopped the advance before the road running N.W. from the Moulin du Piètre past Mauquissart had been crossed. On the night, meanwhile, two Gurkha battalions of the Dehra Dun Bde. pushed forward into the Bois de Bies, but their position was dangerously isolated and they had to be withdrawn E. of Rivière des Laves.

The chances of substantial progress on the second day, already diminished by the arrival of strong German reinforcements, were further reduced by weather conditions which made aerial direction of the British artillery fire impossible. This, combined with the interruption of telephone communications between the forward observing officers and their batteries, prevented the co-operation between artillery and infantry needed to reduce the numerous machine-gun posts furnished by the houses which studded the area N. of Neuve Chapelle. Groups of these, especially along the Moulin du Piètre-Mauquissart road, proved most formidable obstacles. Moreover, the Germans, besides throwing in all the local reserves of their VII. Corps, together with the 6th Bavarian Res. Div. which was resting near Lille, brought up much additional artillery, so that the 7th and Lahore Divs. came under heavy fire and suffered severely in crossing ground in rear of the advanced troops, sometimes without even reaching the front line. The 7th Div. beat back counter-attacks and added considerably to

\* This process, called by the French "nettoyage" and by the British "mopping-up," was the clearance, by troops specially detailed for the purpose, of the enemy trenches that had been reached and passed by the leading troops of the attack but might—and in practice usually did—contain scattered but intact and dangerous groups of the enemy.

the tale of prisoners, but made no real progress; the 8th could do no more, but until the right of the 8th Div. could come forward to cover it the Indian Corps could not tackle the Bois de Biez.

On the next morning (March 12) violent counter-attacks against several points made it obvious that strong German reinforcements had come up. Advancing in mass against the Bareilly Bde. along the Rue du Bois and against the rest of the Meerut Div. N. of Port Arthur, the Germans were mown down in numbers without ever reaching the British line. Opposite the Moulin du Piètre another determined attack broke through the 24th Bde., to be thrown back by a prompt counter-stroke by the 1st Worcesters; and in this quarter also very heavy losses were inflicted on the Germans. Further N. again the 21st Bde. lost some advanced trenches, but successfully maintained its main position and lent effective aid to the 2nd Scots Guards and 2nd Borderers of the 20th Bde., who carried a strong redoubt N.E. of the Moated Grange and took 300 prisoners of the VII. Corps. But still the Moulin du Piètre-Maquisart road barred any advance, and the machine-guns in the fortified houses held up all attempts to get forward. Thus, though the 25th Bde. repulsed several attacks they could not carry the line forward from Neuve Chapelle; the 5th Lhd. Bde. (Lafore Div.) made a little ground and took prisoners but could not cross the Rivière des Layes; and now that all advantages of surprise had gone Sir John French saw that little was to be gained by pressing the attack. March 13 therefore saw the fighting much diminished in intensity; gains were consolidated and the troops reorganized, but the attack was suspended.

The battle of Neuve Chapelle ended therefore somewhat disappointingly. The substantial advance which had at one moment seemed within reach had not been realized; the delay in pushing the British reserves had allowed the Germans to rush to the danger spot reinforcements sufficient to bar the road to the high ground of the Aubers ridge. Thus while the tactical position round Neuve Chapelle was much improved the strategical situation was unchanged. The losses, over 4,200 in the Indian Corps, nearly double that in the IV., had been heavy, while of three minor operations undertaken as diversions those at Givenchy (I. Corps) and Wytchaete (II. Corps) failed, only the III. Corps proving successful against l'Épinette (S.E. of Armentières). Still, it would be wrong to class Neuve Chapelle among British defeats. The troops were undoubtedly encouraged by seeing that German positions could be stormed and the captured ground held against powerful counter-attacks. Nearly 1,700 prisoners had been taken and the German losses had exceeded the British. Rifles, artillery and machine-guns had found splendid targets, and the German battalions who had shown themselves in the open had been shot down in masses. It was felt that another attack in which the lessons of the battle could be turned to good effect might lead to far-reaching results.

(D) AUBERS RIDGE AND FESTUBERT.—The part assigned to the British in the Allied offensive of May 1915 gave them as their immediate objective the S.W. end of the Aubers ridge. The IV. Corps was to attack at Rougebancs, N.E. of Neuve Chapelle, using the 8th Div. in the first assault and supporting it with the 7th, while S.W. of Neuve Chapelle the Meerut Div. (Indian Corps) and the 1st Div. (I. Corps) attacked from the line of the Rue du Bois which joins the Estaires-La Bassée road at the "Port Arthur" cross-roads. It was hoped that these divisions pushing forward in an easterly direction would establish touch behind the Bois de Biez with the IV. Corps advancing southward past Aubers. But whether successful or not in their immediate tasks, the British would materially assist the Allied operations if their attack diverted German guns and men from the crucial point N. of Arras where the French were attacking.

It was with the greatest confidence that the British forces looked forward to this attack. Neuve Chapelle had whetted their hopes; it was believed that at this second attempt the lessons of Neuve Chapelle would be turned to good effect, that the causes which had robbed that attack of greater success

would be avoided, that the increased artillery and ammunition available would allow of a far more effective bombardment. Unfortunately, the delays in renewing the attack, due partly to weather conditions but even more to the insufficient ammunition supply, had given the Germans time to so strengthen their positions that only the heaviest artillery could produce any substantial effect upon them. Parapets, many feet in thickness and backed up by concrete, were proof against 18-pounders, and afforded complete protection against anything short of a direct hit to the machine-guns placed in pits sited at the ground level which swept the "no-man's-land" with a grazing fire. It was only the bitter experiences of May 9 which revealed how very formidable the German defences had become and what an increase in battering-power would be needed to reduce them.

The actual attack delivered early on May 9 met with modified success at Rougebancs, but with complete failure at Rue du Bois. Here the infantry found the enemy's trenches strongly manned; the machine-guns from their pits, at the base of the parapets maintained a deadly fire; scarcely any of the assailants managed to reach the enemy's parapets, and the few who did get into the German lines were promptly overwhelmed. Moreover, the German artillery at once opened a heavy counter-bombardment, and the British supports and reserves, packed into crowded communication and assembly trenches, suffered severely, while the task of evacuating wounded and reorganizing the troops for a second attempt proved extremely difficult. A second effort was, however, made by both the 1st and Meerut Divs. about 7 A.M., though without success; and when in the course of the afternoon the Bareilly Bde. of the Meerut Div. and the 1st Bde. of the 1st Div. were put in, the same result followed. A handful of the 1st Black Watch made a lodgment in the enemy's trenches; but so small a party was powerless and was speedily overwhelmed.

At Rougebancs the right brigade of the 8th Div., the 24th, failed except at one point to reach the enemy's trenches, and suffered very severe losses. On its left, however, the 2nd Rifle Bde. and 1st Royal Irish Rifles of the 25th Bde. captured a considerable frontage, and lodgments were also made by the 2nd Lincolnshires and the 13th (Kensington) London Regiment. However, consolidation proved exceedingly difficult. Machine-guns on the flanks, which could not be located or silenced, prevented the advance of reinforcements; efforts to dig communication trenches came under heavy shelling, and could not be completed before German counter-attacks, vigorously pressed and well supplied with bombs, drove back those assailants who had penetrated beyond the front trenches and gradually forced the survivors out of the positions they had captured: The Rifle Bde. held on longest, keeping the Germans at bay till after midnight, but before the 7th Div. could push a battalion across to relieve them a renewed counter-attack ousted them from the German trenches. The division's losses came to over 4,500, about the same as at Neuve Chapelle, but without the satisfaction of retaining any of the ground won at the first assault. The 1st Div. lost nearly 4,000 men, the Indian Corps had over 2,000 casualties, and the completeness of the failure was the more felt because of the high hopes so generally entertained.

However, though the French attacks had also fallen short of the success anticipated, they had gained some ground and were being continued. Sir John French therefore determined to renew his efforts to assist his allies, though on a less ambitious scale. North-east of the village of Festubert the German lines running northward from Givenchy turned N.E. at a sharp angle towards the Bois de Biez, making a salient which it was proposed to attack on two sides. On the night of May 15-16, therefore, the I. and Indian Corps renewed their attempt to advance from the Rue du Bois, using the Meerut and 2nd Divs., while the 7th Div., which had been transferred from the IV. to the I. Corps, attacked eastwardly from Festubert. The attack was preceded by an intermittent bombardment extending over several days, instead of the short but intensive bombardment employed on March 20 and May 9. Over a large part of the

front attacked the German wire was effectively cut, but opposite the Indian Corps the German parapets successfully defied the efforts of the British artillery and (on the left of the front attacked) the Meerut Div. and the left of the 2nd Div. failed to carry the hostile trenches. The rest of the 2nd Div. fared better; the 6th Bde. and part of the 5th stormed the front German line, and reinforced by their reserves began pushing on against the second line. At 3:15 A.M. on May 16 the 7th Div. attacked, while the Meerut Div. made a fresh attempt. Once again machine-guns sheltered behind Lille damaged parapets and shot down the Gahrwal Bde., and this failure affected the advance of the division, who had to establish a defensive flank on their left and to devote their main efforts to getting touch with the 2nd Div. whose attack had met with considerable success, especially in the centre, where the 2nd Scots Guards and 1st Royal Welsh Fusiliers had penetrated deep into the German positions. On their right also the 2nd Queens, after a temporary check, had got well in, and while they pushed on towards La Quinque Rue a bombing attack down the German front line, S. of the point of entry, led to the clearing of 700 yd. and the capture of 200 prisoners. But casualties had been heavy, and on the left the stubborn resistance of a strong point held up the left of the 20th Bde., which exposed the flank of the most advanced parties. These, out of touch with their supports, were forced back by counter-attacks. Similarly, the progress of the 2nd Div. was retarded by the resistance of two fortified farms, Cour d'Avoué and Ferme du Bois. Until these strong points could be reduced substantial progress was impossible.

Next day (May 17) operations were continued, a special effort being made to close the gap between the 2nd and 7th Divs., after which it was hoped to push on towards Rue d'Ouvert and Chapelle St. Rech. The first of these objects was effected, after about 700 Germans in the angle between the two attacks had left their trenches, apparently intending to surrender, but had been shelled by their own guns and almost wiped out. But the Ferme du Bois held up the 2nd Div., which could only progress to some extent on its right. The 7th Div. started well and cleared the strong points which had checked the left of the 20th Bde., but could not get much further in the direction of Cour d'Avoué, while the efforts of the 2nd Bedfords and 4th Camerons to push on against Rue d'Ouvert were not in the end successful. On May 18 the 4th (Guards) Bde. attacked Cour d'Avoué from the W., but could not carry it, and Canadian infantry, who on that day began relieving the 7th Div., did not succeed in doing more than master an orchard which had been reached (but lost again) on May 16 by some of the 7th Division. By this time the Germans had brought up considerable reinforcements and many machine-guns, and as the ammunition available was nearly exhausted all chance of substantial success seemed gone. For another week, however, severe fighting continued between La Quinque Rue and Givenchy, the brunt falling on the Canadians and on the 47th (London) Div. who were holding the Givenchy sector. These operations resulted in the capture of several hundred yards of trenches, including two formidable strong points, and the repulse of several German counter-attacks, but by May 25 Sir John French found it necessary to call a halt. It was now clear that though the great French effort further S. had won much valuable ground it had failed to break the enemy's line or to prove the decisive stroke that had been hoped for: the Allies had to resign themselves, therefore, to a suspension of active operations. Actually, it was not till the end of June that this became complete, and in the interval two minor attacks were made near Givenchy, one by the 7th and 51st (Highland Territorial) Divs., the other by the Canadians; neither, however, resulted in any appreciable gain of ground, and although on June 16 an attack by the 3rd Div., now in the V. Corps, carried some German trenches W. of the Belleward ridge and improved the tactical situation in the Hooge neighbourhood, it did not lead to the recapture of Hooge and involved the assailants in heavy losses.

For three months, therefore, the position on the British front was one of almost complete stagnation. The only events of

real importance were the arrival of the long-expected "New Army" divisions, the first of which, the 9th (Scottish) Div., actually began its disembarkation at Boulogne on the day of the disastrous repulse at Fromelles and Rue du Bois. By the end of July eight of these divisions were in the country, and their presence permitted the formation of a III. Army, which took over from the French a line to the N. of the Somme between Arras and Albert. During this period there was of course intermittent activity on the British front, mainly in the Ypres salient. Here at the end of July the Germans, making use for the first time against the British of their *Flammenwerfer* (liquid-fire projectors), attacked and captured the right trenches of the 14th (New Army) Div. just S. of Hooge. The battalion holding the trenches was overwhelmed, and a counter-attack next day was unsuccessful. Ten days later, however (Aug. 9), two brigades of the 6th Div. made a fresh attempt after careful reconnaissance and preparation. The German position was carried on a front of 1,000 yd., and heavy losses were inflicted on them; they brought up large reinforcements and strove desperately but unsuccessfully to regain the ground, but the 6th Div. held firm, retaining the trenches lost in the *Flammenwerfer* attack with a small spur N. of the Menin road.

It gives some indication of the difference in scale between the war of 1914-8 and the greatest of the previous campaigns of the British army that the 1,800 casualties of the 6th Div. in this quite minor action exceeded by 50% the losses of Wellington's army at Busaco.

(E) LOOS.—If in the Allied offensive of Sept. 1915 the British army, as in May, played only a subsidiary part, its contribution far outstripped both in men and in materials the meagre preparations of May. A four days' bombardment on a scale hitherto unprecedented preceded the attack, for which nine divisions were available as against the four of May 9, while six others contributed by undertaking diversions. The frontage attacked extended over nearly 6 m., from just S. of the mining village of Loos on the right to the La Bassée canal on the left. The line ran fairly straight from S. to N. for nearly 3 m., but then curved away in a N.W. direction towards Cunchy, so that two of the three divisions of Sir Hubert Gough's I. Corps on the left had to attack N.E., while the right, Sir Henry Rawlinson's IV. Corps, was striking due east. Further, Gough's left division, the 2nd, was to attack on both sides of the canal, the 5th Bde. from Givenchy-lea-La Bassée, the 6th and 38th Bdes. from Cunchy. The 5th Bde.'s attack was one of the operations intended to distract the enemy and divert his reserves, but the other brigades aimed at reaching Auchy and linking up near Haisnes with the left of the main attack. A defensive flank would thus be established, under cover of which, and of a similar flank to be formed on Rawlinson's extreme right by the 47th Div., the central divisions of the I. and IV. Corps with the XI. Corps in support and the cavalry in readiness behind, would, it was hoped, break through between Haisnes and Loos, reach the Doule canal at Port à Verdun and unite E. of Lens with Gen. Foch's troops.

To improve the chances of success and introduce an element of surprise it had been decided to employ against the Germans their own device, gas. Elaborate preparations had been made for the use of this weapon, and on its expected effectiveness in surprising and demoralizing the defenders the highest hopes were based.

The operations to be undertaken as diversions were much more substantial in scale than those which had accompanied the Neuve Chapelle attack. The 19th Div. was to attack in the low ground E. of Festubert. North of Neuve Chapelle the Indian Corps, supported on the left by the 20th Div., was to assault the German salient at Mauquissart, the legacy of the Neuve Chapelle fighting. Further N. again the 8th Div. was to attack at Bridoux, while the principal diversion was that to be undertaken against Hooge and the Belleward ridge on the Ypres front by the 3rd and 14th Divisions. These attacks were more than mere raids; they all aimed at definite tactical improvements in the local situations, but their primary object was to

prevent the transfer of reserves to the main point of attack. This object they achieved, even if they nowhere resulted in permanent gains of ground, for it was only by prompt and vigorous use of reserves and hard fighting that the Germans recovered their initial losses at Hooge, at Bridoux and at Mauquissart where the Indian Corps made a fine fight.

In the preliminary bombardment the field guns were employed to cut the wire, while the heavier guns battered the other defences. Considerable damage was inflicted both on the trenches and their garrisons, though in places deep dug-outs allowed the defenders to escape lightly. Most of the wire was effectively destroyed, but at several points folds of the ground concealed it from observation, and at two at least this had far-reaching effects, parts of the attack, which was delivered at 6:30 A.M. on Sept. 25, being held up by uncut wire. Moreover, the wind proved too weak to carry the gas forward quickly, and thus made it in places worse than useless. This was notably the experience of the 2nd Div. at Cuinchy, and its attack, though gallantly pressed, proved unsuccessful and costly. Better success attended the 9th Div. E. of the railway to Vermelles, though its left brigade, the 28th, found the wire practically intact and was repulsed with heavy losses, a second attack by the supporting battalions faring no better. The 26th Bde. had to assault the formidable and important Hohenzollern Redoubt, which protruded in front of the slag heaps and miners' cottages at "Fosse 8," S. of Auchy. With great gallantry and at a heavy cost the Highlanders carried the Redoubt and swept on over the German main line, clearing the cottages and slag heaps behind. Some of the supports were absorbed in securing this first objective, but the remainder pushed forward and established themselves just short of Haisnes in the Pekin trench, part of the German second line. With prompt support Haisnes might have been carried, but the 27th Bde. were much delayed by the returning wounded and German prisoners who crowded the communication trenches, and before its leading battalions could reach the front the opportunity had passed; German reserves had arrived. All the 9th Div. could attempt was to maintain its gains against the counter-attacks.

Opposite the 7th Div. the chief tactical feature was a group of quarries W. of Cité St. Elie. These were reached and taken by the 22nd Bde., but at a cost which left it too weak to carry its second objective, Cité St. Elie. The 20th Bde., however, penetrated much deeper into the German position, capturing eight guns, and reaching the cross-roads between Cité St. Elie and Hulluch. But it was out of touch with the 22nd Bde. on its left, and as the division's reserves, the 21st Bde., were partly absorbed in consolidating the quarries sufficient reinforcements were not forthcoming to carry the attack any farther. Thus despite its substantial initial success the advance of the I. Corps came to a standstill. The detachments which had established themselves in the German second line were scattered and isolated, and needed both reinforcements and artillery support. But information was scanty and slow to get back to headquarters and without accurate information artillery support was impossible; the immediate reserves had been used up, and as no more were forthcoming the opening could not be exploited.

On the left of the IV. Corps the 1st Div. had as its objective the line from Hulluch to Bois Hugo, N.E. of Loos. Its left brigade, the 1st, was most successful: it stormed the front line and pushed on to Hulluch over several lines of trenches, capturing three guns. But here it found itself unsupported, for the 2d Bde. on its right had been stopped by uncut wire several hundreds of yards long and its repeated assaults proved equally unsuccessful and costly. The reserves of the 1st Div. had, therefore, to be used against its first objective, and not till the afternoon were they able by crossing the German trenches on the flanks of the untaken portion to compel its defenders to surrender. By the time, therefore, that the 2nd Bde. finally reached its objective at Bois Hugo the delay had had serious consequences: the 1st Bde. had already been forced back 500 yd. from Hulluch, and the left flank of the next division to the right, the 15th, had been insecure all day.

Nevertheless, the 15th Div. had achieved remarkable success. Attacking with the 46th Bde. on the left and the 44th on the right, it carried the German front line, swept on over a second-trench system into Loos and through it, and pushed on over "Hill 70," E. of Loos, until brought up by the defences of Cité St. Laurent, one of the suburbs of Lens, and by a railway embankment farther north. But their rapid advance had carried the men beyond the reach of artillery support; mixture of units had destroyed cohesion, and touch had been completely lost with the headquarter formations in rear. Moreover, though some of the 46th Bde. had reached and occupied Puits 14 bis, a mine S. of Bois Hugo, the 2nd Bde.'s failure had left the 15th exposed to counter-attacks from the N., and reserves which might have secured the advanced position had to be diverted to that flank. On its other flank, however, the 15th Div. had no cause for anxiety. The 47th (London) Div. had as its task the formation of a defensive flank from the S.E. of Loos back to the British front line. This task it had accomplished to the letter, capturing three guns and several hundred prisoners, and after consolidating all its objectives it maintained them against vigorous counter-attacks.

About noon, then, on Sept. 25 the prospects of a breakthrough seemed bright. If reserves could have been promptly pushed in, the arrival of German reinforcements might have been forestalled and the advanced troops not only supported but carried farther forward. Unluckily, neither Gough nor Rawlinson had reserves available, and at noon the leading troops of the XI. Corps were still 3 m. from the original German front line and had to thread their way forward through an area congested with transports and with traffic of every description. More guns meant larger ammunition columns, while additional machine-guns meant additional limbers, and the rapid expansion of the British army had not only meant increased impedimenta but had brought into staff posts many officers without staff training or experience. The congestion of the rearward areas was a serious handicap, but hardly to be wondered at.

By the time the leading units of the XI. Corps reached the front matters had already changed for the worse. At nearly every point German counter-attacks had thrust back the most advanced troops, and though the Germans had had to pay heavily for their gains the fact that their reinforcements were arriving in strength was even more serious than the loss of ground. At Hill 70 in particular there had been desperate fighting, and only with great difficulty had the 15th Div. maintained a position on its western slopes, thanks largely to the initiative of a battalion commander who, arriving there after the advance had swept on over the crest, had promptly entrenched a position on which the remnants of the advanced troops were able to rally when the counter-attack drove them back. But now that the XI. Corps was up it was hoped to push on again next morning.

The plan for Sept. 26 was that the IV. Corps, reinforced by the 21st and 24th Divs., should renew the attack from Loos to Hulluch. As a preliminary portions of the 15th and 21st Divs. were to recover the crest of Hill 70. However, as their attack started the Germans began a series of heavy counter-attacks from Bois Hugo southward, and succeeded in driving out of Bois Hugo the brigade of the 21st Div. which had just relieved the 2nd Bde. there. Profiting by this they pressed in on the left flank of the 15th Div. and gradually forced it back. Farther S. the efforts of the 45th and 62nd Bdes. to carry Hill 70 were held up by wire which the Germans had rapidly put up, and by a redoubt on the crest. Moreover, when the main attack was delivered it was mainly by enfilade machine-gun fire from Bois Hugo that the 24th Div. was repulsed and driven back. All efforts of the 21st Div. to recover Bois Hugo failed; the 1st Div. could effect nothing by itself, and it was largely the possession of Bois Hugo and of Puits 14 bis which finally enabled the Germans to thrust the defenders of Hill 70 down the hill in upon Loos. That village, however, was secured by the arrival of the 6th Cav. Bde., and N. of Bois Hugo the Germans did not attempt to advance beyond the La Bassée road.

To the I. Corps also Sept. 26 had brought disappointment. Shortly before midnight (Sept. 25-26) a German attack broke through at the junction between the 7th and 9th Divs. and penetrated into the quarries, which passed back into German hands, the left of the 7th Div. recoiling to the old German support trenches. On its right the 7th Div. maintained all but its most advanced positions, and linked up with the 1st in front of Hulluch, but two attempts to recover the quarries failed. At Fosse 8 the 73rd Bde. of the 24th Div. (which had relieved the 26th Bde.) had great difficulty in holding its ground against counter-attacks. Fosse Alley, however, the intermediate line between the front system and Haines, which had been evacuated when the quarries were lost, was reoccupied and held by the 27th Bde., and the Germans had to pay highly for such ground as they regained. But they had now brought up several fresh divisions, and pressed their attacks hard, especially against the inexperienced 73rd Brigade. Before midday on Sept. 27 these troops, short of ammunition, food and water, and quite unable to reply effectively to the German bombers, were driven out of their positions. A dashing advance by the remnants of the 26th Bde. prevented the loss of the Hohenzollern, which had seemed imminent, but the recapture of Fosse 8 and the dump made Fosse Alley untenable and compelled its evacuation. Against the 7th Div., however, the Germans were less successful, and Sept. 27 saw the right of the position of the I. Corps fairly satisfactorily consolidated.

While the I. Corps had been defending its gains, the IV. had been striving to make more. During the night of Sept. 26-27 the Guards Div. had relieved the 21st and 24th opposite Hulluch and Bois Hugo. On the afternoon of the 27th its 2nd Bde. attacked Bois Hugo and Puits 14 bis, while its 3rd advanced through Loos against Hill 70. Both attacks were splendidly pressed and achieved valuable gains. Chalk Pit Wood was reached and secured, though Puits 14 bis could not be held against heavy counter-attacks, and a line was established just W. of the La Bassée road to link up with the 1st Div. opposite Hulluch. Similarly the 3rd Guards Bde. put Loos out of danger of recapture by making good a line just below the crest of Hill 70.

By the evening of Sept. 27 all hopes of a speedy and decisive success were gone. No break-through had been achieved, and Gen. Foch's attack also had been checked. Still the vigour with which the Germans hurled counter-attack after counter-attack at the positions taken from them testified to the value they attached to them. The fighting was fiercest round the Hohenzollern Redoubt, which the 28th Div. took over from the 9th on Sept. 28 and held under considerable difficulties till Oct. 3, when a specially violent attack drove them from its ruins, though even then they retained a substantial portion of the 9th Div.'s gains of Sept. 25. On Oct. 5 the Guards relieved the 28th Div., and during the next week made several minor gains by bombing-attacks. Fighting was also heavy without producing any marked change in the tactical situation round the quarries on the frontage held in succession by the 7th, 2nd and 12th Divisions. From the Vermelles-Hulluch road to Loos the Germans were less aggressive, their only serious effort on this front being on Oct. 8, when they attacked in great force, only to be repulsed with very heavy losses especially by the 1st Div. at Chalk Pit Wood and by the French, who had taken over Loos itself on Sept. 30.

After this repulse the Germans made no more big counter-attacks. By recovering the dump and Fosse 8 they had won back observation posts which overlooked much of the salient which the battle had produced. Sir John French was naturally loth to abandon the effort to recover them, and decided to bring up the 46th (North Midland) Div. for a fresh attack on the Hohenzollern Redoubt, while simultaneously the 12th and 1st Divs. should attack the quarries and Hulluch. The attack, delivered on Oct. 13, was only partially successful, but did result after heavy fighting in the recovery and retention of the bulk of the redoubt. The 12th Div. failed to retake the quarries, but made useful gains which improved its line. The 1st

Div., however, once again found Hulluch too much for it, so that the net result of the attack did not encourage a repetition, and with this major operations in the battle area ended. The French continued attacking in Champagne for some weeks, though even there all prospect of decisive success was gone, while in Artois they had already abandoned their offensive.

When the results of the British offensive are set against the high hopes entertained before the attack it is excusable to write it down as a failure. The gain of ground was not worth the 50 to 60 thousand casualties incurred in its capture, but the German losses on the British front were almost as heavy, and the capture of over 20 guns and 3,000 prisoners was no small encouragement. It had been shown that the Germans could be driven from positions they believed impregnable. Moreover, valuable experience had been gained not only in the use of the new weapon, gas, but in staff work, in administrative arrangements and in tactics, experience to be turned to good account in 1916. At Loos an effort had been made to apply the lessons of Neuve Chapelle. It was partly because Neuve Chapelle had shown the dangers of retaining too close a hold on the immediate reserves that it had been arranged that the troops (immediate reserves included) were to press forward without limitation. Loos showed the advantages of the "limited objective" and of dealing with untaken portions of a hostile line rather by outflanking them than by renewing direct attacks; it also showed that the patterns of grenades in use in the British army were too varied and mostly unsuitable for wet weather, with other lessons major and minor. It is easy in the light of the experience gained at and after Loos to criticize the whole plan as too ambitious for the resources, human and material, at the commander-in-chief's disposal; to point out the unwisdom of employing raw troops in a great battle within a fortnight of their landing in France; to argue that, had the frontage attacked been narrower and the divisions disposed in greater depth, more immediate reserves would have been available. Still the balance remains on the side of gain. Loos inflicted heavy losses on the Germans; it was a foretaste of heavier losses in store for them. The performances of the 9th, 12th and 15th Divs. showed that the improvised "New Armies" of Britain were likely to prove a factor of decisive importance in the war.

(C. T. A.)

(F) THE GERMAN RETREAT TO THE HINDENBURG LINE, 1917.—In order to follow intelligently the operations which took place during the early part of 1917 it is necessary to understand thoroughly the situation which had arisen and the general atmosphere which had been created as a result of the prolonged fighting on the Somme. In Dec. 1916 Gen. Nivelle was appointed to the chief command of the French forces. He declared great confidence in his ability to break through the enemy's defences by the delivery of a mighty blow specially prepared, and immediately disclosed his project to the British commander-in-chief, Sir Douglas Haig. The plan was briefly as follows: (a) to deliver the main attack by three French armies on the Aisne front—one of these armies to be in reserve for purposes of exploitation; (b) to deliver a subsidiary attack by the British army on the Arras front; (c) to undertake minor actions between Reims and Arras to contain the enemy; (d) vigorous exploitation. In order to give effect to these proposals and to enable the French to undertake the major operations with large reserves, Gen. Nivelle's plan included the relief of French troops by the British as far S. as the Amiens-Roye road. The weakness of this plan, apart from the Russian revolution and release of German reserves, which could not be foreseen, lay in the imposition of the major task on the French armies, already exhausted by two years of heavy fighting and the strain of the defence of Verdun, while the British, at the height of their strength and vigour, instead of being trained and concentrated for a vigorous blow, were relegated to defensive work and the minor rôle. These operations were to take place as early as possible, and it was hoped that the respective attacks would be launched early in April. The Somme battles had evidently shaken the enemy seriously, and had caused his defensive front

In the neighbourhood of the Ancre to become a pronounced and dangerous salient. Moreover, it was known that he was constructing a rearward line of defence, subsequently known as the Hindenburg Line, which would materially shorten his defensive front and thus release a number of divisions which could be moved into reserve.

Such was the position of affairs on Jan. 1 1917. The maintenance of pressure on the enemy on the Ancre-Somme battle-front was now of immediate importance. Signs were not lacking that the enemy had considerably weakened, and his position in the Ancre salient was vulnerable and dangerous. After a period of bad weather it became possible during Jan. to undertake minor and local operations, which resulted in the capture of the Beaumont Hamel spur, thus opening up a wide field of view and observation for artillery fire. No time was lost in making use of this advantage. Indeed, it was essential to engage the enemy closely, whether it was his intention to retire voluntarily to some previously prepared position, or whether his defence was involuntarily weakening. The country on both banks of the Ancre consists in pronounced undulations with spurs running towards the stream from both north and south. Opportunity was offered for skill in the handling of comparatively small bodies of troops, in making use of the ground, and of coöperation both by movement and by fire. Making use of the tactical advantage obtained by possession of the Beaumont Hamel spur, the 63rd Div. carried out a successful operation early in Feb. which carried the British front forward on the N. bank of the river. This assisted towards the capture of a point on the S. bank, which gave observation into the upper valley of the Ancre and over the German gun positions. These hostile batteries which protected the Serre salient were forced to withdraw, thus weakening to a dangerous degree the German defences to the north. It was now possible to attack with advantage the Serre-Beauregard and Courtelette-Miraumont ridges, the possession of which, besides turning the German defences on the N. in the neighbourhood of Gommecourt and Monchy, would open up a further field of view up the valley of the Ancre, where many hostile batteries had been located. In order to gain this position an assault was delivered on the morning of Feb. 17 by the 2nd, 18th and 63rd Divs. on both banks of the stream. On the N. bank the attack was completely successful, while on the S. bank considerable resistance was encountered. Nevertheless, the whole position was occupied shortly afterwards, and small detachments and patrols working forward succeeded in occupying the enemy's defences on a wide front from opposite Guedecourt to Serre, including the villages of Warlencourt and Miraumont as well as the Beauregard spur.

It had become increasingly evident that the German defence was weakening, and their troops were being gradually withdrawn, the first indications being on a narrow front in the valley of the Ancre, but now on a more considerable scale. The prolonged period of exceptional frost following on a wet autumn had frozen the ground to a great depth. The thaw, however, began in the third week of Feb.; the roads, disintegrated by the frost, now broke up, and the area of the 1916 battlefield became a quagmire. On the other hand the conditions of the weather favoured the defenders, who fell back on to fresh unbroken ground, and the succession of misty days covered their movements.

Notwithstanding these difficulties the British and Australian troops kept up constant pressure, and by the delivery of minor attacks drove the enemy from position to position, until by the end of Feb. the whole of the Ancre valley and the higher ground to the N., including the village of Gommecourt, fell into their hands. The enemy had now evidently fallen back into a previously prepared line of defence—the trench system known as the Le Transloy-Loupard line, cutting off the Ancre salient and covering the villages of Le Transloy, Gréville, Achiet-le-Petit and Bucquoy. It was possible that he would make a stand on this defensive line. If not, undoubtedly his withdrawal would be conducted on a more comprehensive scale altogether and on a wider front.

Owing to the heavy work required to be executed in rendering the roads passable, and moving forward guns, ammunition and supplies, in addition to the necessity for gaining ground to within assaulting distance of this defensive system, a delay of a week occurred before operations of a more serious character could be undertaken. On March 11 and 12 the Le Transloy-Loupard line was subjected to so effective a bombardment that on the morning of the 13th the enemy abandoned this strong position. Gréville and Loupart wood were immediately occupied, and preparations put in hand to attack the enemy's next line of defence, which covered Bapaume and Achiet-le-Grand.

For some time prior to this date indications had been observed of a further and wider extension of the German withdrawal. It had been ascertained that the Germans were preparing with feverish haste a new and powerful defensive system, the Hindenburg Line, which, branching off from the original defences near Arras, ran S. E. for 12 m. to Quéant and thence passed W. of Cambrai in the direction of St. Quentin. The immediate object appeared to be to escape from the salient between Arras and Le Transloy, but it was also evident from the preparations the Germans were making on a grand scale, that they contemplated an eventual evacuation of the greater salient between Arras and the Aisne valley N.W. of Reims. The withdrawal to the Hindenburg defences would cause a very considerable contraction in the length of the line, with a consequent increase of the German reserves. It was evident that the Somme battles of 1916 had materially reduced his strength, and with the expected onslaughts on the western front, coupled with a Russian offensive on a grand scale, it was necessary for them to contract the front and conserve their strength.

Constant watch had accordingly been kept by the British along the whole front S. of Arras, strong patrols, kept alert and active, pushing forward here and there, with the result that St. Pierre Vast wood was occupied on March 16. Meanwhile information was received which indicated the reduction of the enemy's forces S. of the Somme, and pointed to the probability that his line in that sector was being held by rear-guard detachments supported by machine-guns, whose withdrawal might be expected at any moment.

It was evident that the enemy was withdrawing according to a carefully prepared plan along the entire front of recent operations and on both banks of the river Somme. Orders were accordingly given by the British G.H.Q., in conjunction with the French, for a general advance on the morning of March 17. Except at certain localities where detachments of infantry and machine-guns had been left to cover his retreat, there was little serious resistance to the advance, and that resistance was rapidly overcome.

On March 17 Chaules was captured by the 61st Div. and Bapaume by the 2nd Australian Div., while further to the right the French entered Roye. On the following and subsequent days the advance continued, and the whole intricate system of German defences in this area, consisting of many miles of powerful well-wired trenches which had been constructed with immense labour, passed into the hands of the Allies.

On March 18 the British 48th Div. gained the important tactical position of Péronne, and Mont St. Quentin which lies above it. The possession of this locality at the angle of the Somme showed clearly that the enemy would not stand on the line of the river, for it outflanked that line to the south. The bridges over the Somme, which had been systematically destroyed, were temporarily and partially repaired with great rapidity, and the British troops, passing over, deployed into open country with patrols and cavalry thrown forward.

By this time the Allies' advance had reached a stage at which the increasing difficulty of maintaining the communications rendered it imperative to slacken the pace of the movement. Not only had the bridges over the river Somme been destroyed, and the roads rendered almost impassable both artificially and from the weather, but the wide belt of devastated ground over which the Somme battle had been fought offered immense difficulties to the passage of guns and transport. Moreover, in



front lay an enemy whose armies were capable of launching a vigorous counter-offensive. Strong detachments of his infantry and cavalry occupied tactical points along the line of advance, serving to keep the enemy supplied with information and as a screen to his own movements. His guns, which had already been withdrawn to previously prepared positions, were available at any moment to cover and support a sudden counter-stroke, while the conditions of the country across which the Allies were moving made the progress of their own artillery unavoidably slow. The bulk of the enemy's forces were known to be occupying a very formidable defensive system, upon which he could fall back should his counter-stroke fail. On the other hand the Allies, as they moved forward, left all prepared defences farther and farther behind them. In such circumstances the necessity for caution was obvious. In order to combat these dangers and difficulties, the Allies were compelled, at the various stages of the advance, to select and put into a state of defence successive lines of resistance, which the main bodies would occupy, and in which they could give battle in the event of a hostile riposte. Meanwhile advanced guards, patrols and reconnoitring detachments pushed ahead and maintained touch with the enemy, and roads, railways, bridges, telegraphs and telephones were constructed or restored with rapidity.

As the Allies approached the Hindenburg Line, the resistance of the enemy stiffened and the fighting for the various tactical localities became more severe. During the first week in April the British had almost reached the Hindenburg Line, and had gained possession of the villages of Lempire, Epéhy, Metz-en-Couture, Lagnécourt, Noreuil, Croisilles, Henin-sur-Cojeul and Beaurains. The enemy was now withdrawn to his great defensive line, which he had taken months to prepare, shortening his front considerably and enabling him to bring several divisions into reserve. He had in front of him a devastated zone where the mounting of an Allied attack would present extreme difficulties, thereby releasing yet other troops from the guard of the trenches to pass into reserve.

(G) BATTLE OF ARRAS (April-May 1917).—At the close of 1916, and before the appointment of Gen. Nivelle to the command of the French forces, a general plan had been agreed upon by all the Allies to conduct a simultaneous offensive on all fronts. The British part in this offensive was to consist of a double attack along the Scarpe and Ancre valleys, to cut off the Gommecourt salient created as a result of the Somme fighting. The V. Army was to attack along the Ancre, the III. Army was to debouch from Arras along the Scarpe, while the I. Army (Canadian Corps) was to secure the left flank of these operations by seizing the Vimy ridge. Owing to the exhaustion of the French armies the main operations were to be conducted by the British, who would not press the attack unduly in the direction of Cambrai, but be prepared to switch rapidly to the N. and undertake further operations of greater dimensions in Flanders.

The appointment of Gen. Nivelle in Dec. 1916 to the chief command of the French, and the acceptance of his plan of offensive, dislocated the strategical plans for the British armies at this particular juncture.

The Nivelle plan gave the French the major rôle, as indicated earlier, namely, that of delivering a decisive blow from the Aisne front, while the British operations in Artois were to be of a subsidiary character. It is to be noted in this connexion that the extension of the front in relief of the French caused a reduction of power to the British which materially affected their operations throughout the remainder of the year. The Nivelle plan relied on the success of the main offensive by the French, but if that failed the subsequent operations would be seriously handicapped. This was a matter of first-class importance, seeing that the French had already been overstrained while the British were reaching the height of their strength and efficiency. Apart from this, the actual tactical scheme and dispositions required little modification as a result of the acceptance of the Nivelle plan.

General Nivelle did not altogether approve of the plan of the British commander-in-chief, and urged that the attack on the

Vimy heights should be abandoned and that the concentration should be effected farther S. on the Arras-Ancre front, pointing out that the inclusion of Vimy would cause too wide an extension and dissipation of force. This point is of some interest as showing the difficulties which a commander has to face in the selection of his front of attack and objectives. Sir Douglas Haig had, however, given the closest attention to the various factors affecting the situation, and refused to give way. His arguments were mainly two: firstly, that the capture of the Vimy ridge was essential to secure the left of his operations, and secondly, that any attack mounted S. of Arras, and S. of the point where the Hindenburg Line hinged on the main German front, would be delivered into a pocket or would be entirely dislocated by a voluntary withdrawal of the enemy from the Gommecourt salient, whereas the German forces were bound to stand and fight for the Vimy ridge. The British commander-in-chief scented the retreat of the Germans to the Hindenburg Line and laid his plans to meet that eventuality. The result was that even after the German retreat little or no alteration was necessary. Had he, however, given way to the pressure placed upon him and mounted his attack from Arras to Gommecourt, the operation, which was required by Gen. Nivelle to draw in the hostile reserves and pave the way for the main French attack on the Aisne, could not have taken place at all.

The task of the British was to attract as large forces of the enemy as possible and so reduce the opposition to the French. As soon as the German retreat developed, all those troops and heavy artillery which were not required with the V. Army in its advance from the Ancre were diverted to the III. and I. Armies in order to strengthen their attacks to the utmost.

The preparations for a great offensive, whose reliance is placed on artillery to destroy the enemy's defences and reduce his fire-power to such a point as to enable a successful advance to be made, are extremely long and arduous. When transport requirements on the Arras front were first brought under consideration, the neighbourhood was served by two single lines of railway leading to Arras, the combined capacity of which was less than half the requirements. Considerable constructional work, therefore, both of standard- and narrow-gauge railway, had to be undertaken to meet the programme. Roads had to be improved and adapted; new roads had to be constructed, and material massed forward for construction across the enemy's defences as soon as the troops advanced. For this latter purpose use was made both in this and in later offensives of plank roads. These were built chiefly of heavy beech slabs laid side by side, and were found to be of great utility, being capable of rapid construction over almost any nature of ground. By these means the accumulation of the vast stocks of munitions and stores of all kinds required for the offensive, and their distribution to the troops, were made possible. Hutting and other accommodation for the troops concentrated in the area had to be provided in great quantity; an adequate water-supply had to be guaranteed. Very extensive mining and tunnelling operations were also carried out. In particular, advantage was taken of the existence of a large system of underground quarries and cellars in Arras and its suburbs to provide safe quarters for a great number of troops. Electric light was installed in these caves and cellars, which were linked together by tunnels, and the whole connected by long subways with the trench systems E. of the town.

A problem peculiar to the launching of a great offensive from a town arose from the difficulty of ensuring the punctual debouching of troops and the avoidance of confusion and congestion in the streets both before the assault and during the progress of the battle. This problem was met by the most careful and complete organization of routes.

Practically the labour of the whole of the troops was required to carry through all this work, and while this immense task was proceeding, the British IV. and V. Armies were vigorously pursuing the enemy to the Hindenburg Line, and the French front was in process of being relieved as far S. as the Amiens-Roye road. All this placed a heavy strain on the British troops.

Meanwhile, during the first three months of 1917, negotiations of fundamental importance were proceeding between the high commands and the Governments of France and Great Britain, touching on the principle of unity of command. General Nivelle desired to secure the command of all the forces involved, both British and French. Certain differences of opinion early declared themselves between the British and French commanders-in-chief. These were chiefly in the first instance in connexion with the date of attack, and the extent to which the French troops in front line should be relieved. The transportation service and the Nord railway were not equal to the work of operations on so great a scale at so early a date as that proposed by Nivelle, and in view of the fact that the British commander-in-chief desired to give his troops some rest and training and was somewhat sceptical as to the degree of success which would be attained by the French, was desirous of limiting the extension of his front to the Amiens-Villers Bretonneux road. A temporary agreement on Jan. 1 that the attack should take place as early as possible, and that the French should be relieved as far as the above road by the end of Jan., did not satisfy Gen. Nivelle; the latter referred the whole question to his Government and, indirectly, to the British War Cabinet, with the result that a Cabinet meeting was held in London on Jan. 15 at which both Sir D. Haig and Gen. Nivelle were present. The conclusions arrived at were as follows: (a) the British to relieve the French forces as far S. as the Amiens-Roye road, relief to be completed by March 1; (b) the offensive to commence on April 1 at latest; (c) vigorous exploitation to be undertaken by all the forces both French and British, if necessary. The French troops in front line were accordingly relieved to the Amiens-Roye road, and preparations pushed forward to deliver the attack at the earliest possible date. But the transport difficulties had become so acute that, notwithstanding the fact that every available British soldier was utilized for railway construction and other work, a serious breakdown in the Nord railway system appeared to be inevitable, and the matter had to be referred to the French Government with a view to obtaining greater facilities. Further negotiations in regard to the problem of command took place secretly between the British and French Governments, and materialized in the Calais conference on Feb. 26 and 27 1917. This conference had originally been summoned to discuss the question of transportation. There were present: M. Briand (premier), Gen. Lyautey (Minister of War), Gen. Nivelle (French C.-in-C.), Mr. Lloyd George (British Prime Minister), Gen. Robertson (C.I.G.S.), Sir D. Haig (British C.-in-C.), Gen. Kiggell (C.G.S.). A scheme was set before the conference by the French Government for the establishment of an Allied G.H.Q. and the appointment of a French generalissimo, and the breaking up of the British divisions to form an "amalgam" with the French troops. General Robertson and Sir D. Haig were in complete ignorance of this proposal until the cut-and-dried scheme was produced; the British Prime Minister, however, while opposing the French proposal to break up the British army and form an "amalgam" with French brigades, directed these two officers to draw up a scheme of command, by which the control of operations in the coming battle would be solely in Gen. Nivelle's hands, and the British army under his orders. This was the decision of the War Cabinet. The scheme was accordingly drawn up in the course of the morning of Tuesday Feb. 27, so that when the conference met at 11:30 A.M. on that day, discussion was limited to questions of detail. Finally the French War Committee and British War Cabinet agreed to the following arrangements:—

(1) The British War Cabinet recognizes that the general direction of the campaign should be in the hands of the French commander-in-chief.

(2) The British commander-in-chief to conform his plans to those of the French during the preparation and progress of the projected campaign.

(3) Within the limits of (2) the British commander-in-chief will be permitted to utilize his own resources and forces in the manner which he considers most desirable.

(4) In regard to (2) an exception will be made in a case where he considers that such action would endanger the safety of the army

or prejudice its success; in that case a report shall be made, together with the reasons, for the information of the War Cabinet.

(5) The respective Governments will decide the date at which the operations referred to in (1) and (2) shall be deemed to be at an end.

As all students of war agree, within the army of a combatant nation, unity of control is essential to secure the most effective execution of military operations. In theory, it is equally desirable in all circumstances. There is, however, a difficulty inherent in applying the principle of unity of control to Allied nations. This difficulty lies in the incidence of responsibility. For example, if the British armies are placed under the command of a French general, the British commander cannot be held responsible to the nation. The responsibility for the British armies cannot devolve on the French commander, and must therefore devolve on the British Government. At the Calais conference, however, an effort was made by the British War Cabinet to make the field-marshal commanding the British forces retain responsibility by instructing him to conform his preparations to the views of the French commander, except in so far as he considered that this would endanger the safety of the army or prejudice the success of its operations.

The battle of Arras was the first occasion on which the experiment was tried of securing a form of unity of command, and after the conference of Calais the British forces to be engaged in the battle were placed, within the limitations noted above, under the general control of Nivelle. Certain differences of opinion, however, still existed, and the whole question was again referred to the Governments, with the result that the two commanders-in-chief and two Cabinets met in London on March 13 in order to define the position more clearly.

During the month of March, as previously narrated, the Germans continued to withdraw to the already prepared Hindenburg Line, followed up and pressed by British troops, until early in April they were established in positions covering that line. On the British side, the extensive preparations necessary were pushed ahead as quickly as possible and so far as the available transport facilities permitted. The general plan agreed upon was that the British attack should be launched as early as possible in April and that the French main attack on the Aisne should follow two or three days later. This was to permit and induce the German reserves to be drawn into the British battle and towards the British front, and thus enable the main attack by the French to be delivered with greater prospects of success and exploitation. The British actually launched their assault on April 9, but for reasons of unfavourable weather the French postponed their attack until April 16. Prior to the offensive the new German lines of defence on the British front ran in a general north-westerly direction from St. Quentin to the village of Tilloy-Jes-Mofflaines just S.E. of Arras. Thence the German original trench systems continued northwards across the valley of the Scarpe to the Vimy ridge which, rising to a height of 475 ft., dominates the country eastwards. The front attacked by the III. and I. Armies on the morning of April 9 extended from just N. of the village of Croisilles, S.E. of Arras, to just S. of Givenchy-en-Gohelle at the northern foot of the Vimy ridge, a front of nearly 15 miles. The enemy's defences comprised the normal powerful defensive front consisting of three separate and heavily wired trench systems, and in addition, from 3 to 5 m. further E. a new defensive system, known as the Drocourt-Quéant line, which in fact was a northward extension of the Hindenburg Line, branching from that line at Quéant.

The great strength of these defences demanded very thorough artillery preparation, and this in turn could only be carried out effectively with the aid of the air service. A greater mass of artillery, both guns and howitzers, was used for preparation in proportion to the front engaged than had yet been available in any previous British attack. Three weeks prior to the attack the systematic cutting of the enemy's wire was commenced, while the heavy artillery searched the enemy's back areas and communications. Night firing, wire cutting and bombardment of hostile trenches, strong points and billets continued steadily

and with increasing intensity on the whole battle-front till a few days before the assault when the general bombardment was opened. During this latter period extensive gas discharges were carried out and frequent raids undertaken by day and night along the whole front of attack.

Aircraft were incessantly at work during the whole of this time not only in air fighting and directing the artillery fire, but also in photographing the enemy's defences so as to ascertain the extent of damage effected and the best means of approach for the infantry. Much intelligence and information was gleaned from these photographs as to the progress of the preparation, and from the raids as to the condition of the enemy, and any modifications in regard to his method of holding his defences.

The general object of the attack was to engage and absorb the maximum number of hostile troops; the general plan was to secure the high ground at Monchy-le-Preux and the Vimy ridge and to bring the V. Army into effective operation on the southern flank of the battle; the general method of attack was a succession of comparatively short and deliberate advances, the separate stages of which were arranged to correspond approximately with the enemy's successive trench systems. As each stage was reached a short pause was to take place according to a prepared time-table to enable the troops detailed for the attack on the next objective to form up for the assault.

Tanks were allotted to each corps for specific tasks, such as the capture of the powerful redoubts of Telegraph Hill and the Harp (just S. of Tilloy-les-Mofflaines) and Railway Triangle, a stronghold formed by the junction of the Lens and Douai railway lines E. of Arras. The whole scheme of attack along the entire 15-mile front was carefully co-ordinated. A special feature in the operation was the debouching of the troops to the assault directly from the town of Arras, the subterranean passages and caves of which had been prepared so as to harbour the reserve troops and enable them to pass protected to the trench systems, and so to the assault.

The troops engaged in the attack were as follows (from S. to N.): III. Army (Gen. Sir E. H. H. Allenby), VII. Corps (21st, 30th, 56th, and 14th Divs.), VI. Corps (3rd, 12th, 15th, and 37th Divs.), XVII. Corps (9th, 4th, 34th, and 51st Divs.), I. Army (Gen. Sir H. S. Horne), Canadian Corps, 1st, 2nd, 3rd, and 4th Canadian Divs., and 13th Bde. (5th British Division). In all there were 17 divisions, with 989 heavy guns and 1,890 field pieces. In addition the Cavalry Corps was brought forward behind the III. Army, in case the development of the battle should give rise to an opportunity for the employment of mounted troops.

The general attack on April 9 was launched at 5:30 A.M. under cover of a heavy and effective artillery barrage; the infantry advanced everywhere, and within 40 minutes the whole of the German first line system had been stormed and captured, except at the northern extremity of the Vimy ridge. At 7:30 A.M. the advance was resumed according to programme; more severe fighting took place in view of the greater opposition encountered. Several strong points and localities were stubbornly held by the enemy, but by 12 noon the whole of these and all the second objectives with the exception of the railway triangle had fallen, from Neuville Vitasse as far N. as La Folie farm. As always happens in such a battle, the enemy's troops managed to retain certain tactical localities. Meanwhile the artillery was brought forward to support the attack on the third objectives. Owing to the long range the wire in front of the enemy's third trench system had not been effectively cut in many places; nevertheless good progress was made, and many batteries were captured.

The battle now inevitably became more ragged, owing to the increasing opposition and to the local modification of plans necessitated by the unexpected occurrences inseparable from the battlefield. South of the Scarpe, St. Martin and Feuchy Chapel on the Arras-Cambrai road were captured. In the Scarpe valley the 15th Scottish Div. after a long struggle stormed the railway triangle, and moving rapidly forward captured the village of Feuchy. The 37th Div., hitherto in reserve, whose rôle it was to pass through the first-line troops

to the assault of the high ground and village of Monchy-le-Preux, endeavoured to widen the breach made in the enemy's third line of defence in order to carry out its task, but was held up by the wire. South of the Scarpe, the enemy's third line had been captured in places, but he still retained possession of the greater portion of it, together with the high ground of Orange Hill and Monchy-le-Preux. North of the Scarpe practically the whole of the day's programme was carried through. On the right the 4th Div. in reserve passed through the troops in front line, and according to plan captured the village of Fampoux, thus making a great breach in the enemy's third system of defence. In the centre the Canadian Corps stormed the Vimy heights, entrenched itself on the eastern slopes, and sent patrols out along the front. On the left the 4th Canadian Div., encountering violent opposition at Hill 145 on the northern extremity of the ridge, was compelled to postpone the attack till the following day.

The operations of April 9 had been eminently successful, in spite of heavy squalls of snow and rain; and large numbers of the enemy's troops and guns had been captured.

During the night of the 9th to 10th the 37th Div. made progress through the break in the German third line S. of the Scarpe, advancing to the northern slopes of Orange Hill; and on the morning of the 10th about noon the advance became general, the whole of the enemy's third line S. of the Scarpe being reduced, and the 37th Div. reached the north-western edge of Monchy-le-Preux. A great struggle then centred round this village, and all efforts of the infantry to seize it directly, and of the cavalry to pass around either flank of it, failed, chiefly owing to the lack of effective artillery support due to the long range and the rapidity of the advance. On the morning of the 11th, however, assisted by tanks, the fight was resumed, and by 9 A.M. the village was captured, and subsequently many counter-attacks repulsed.

Meanwhile the Germans had been stubbornly defending the Cojeul valley and the Hindenburg defences at their junction with the old third line, a vital part of the front, where the open forward slopes, swept from end to end by the enemy's machine-guns, rendered any advance extremely difficult. In this area an operation of a bold and hazardous character was undertaken on the morning of the 11th, which was nearly successful. At 4:30 A.M., in conjunction with an attack by the right of the III. Army on Hemnil and Wancourt, the V. Army (4th Australian and 62nd Div.), assisted by tanks, made a gallant effort to breach the Hindenburg Line in the neighbourhood of Bullecourt. The execution of the attack, being over a wide extent of open country, was exceedingly difficult; Australian troops, however, penetrated as far as Riencourt-lez-Cagnicourt and the 62nd Div. reached Bullecourt, but owing to determined opposition and the failure of the attacks by the right of the III. Army these positions could not be maintained. Had both attacks been successful and the two armies joined hands forward, a very wide breach in the enemy's defences in an important area of the battlefield would have been effected with far-reaching results. It was not till the morning of April 12 that the 21st and 56th Divs. succeeded in capturing Hemnil and Wancourt.

North of the Scarpe much fighting of an indeterminate nature took place at Roeux and the neighbourhood on this day, but at the extreme northern extremity of the battlefield the 4th Canadian Div. and 24th Div. secured the whole of the important positions on the flank of the Vimy ridge and astride the Souchez river at the "Pimple" and "Bois en hache." The Germans now began to withdraw from the eastern slopes of the Vimy ridge, and British and Canadian patrols moved forward until by the evening of April 14 a line had been reached N. of the river Scarpe from Roeux to E. of Bailleul-Hirondelle Wood and Liefvin to the old front line at the Double Crassier.

On the right by the evening of the 14th the attacking troops had fought their way forward with great difficulty along the Hindenburg Line as far as Fontaine-les-Croisilles and Wancourt Tower, while farther N. many counter-attacks on Monchy-le-Preux were repulsed.

The main offensive by the III. and V. Armies terminated on the 14th, the artillery support was becoming inadequate, and the troops in front line required relief. A remarkable success had been gained, the British front line had been moved forward some 4 m., and some 13,000 prisoners and 200 guns had been captured. It was not possible, however, to break off the battle, seeing that the French offensive was on the point of being launched, and it was important that the full pressure of the British operations should be maintained in order to assist it. Much had already been accomplished; the enemy had been compelled to pour men and guns into the breach, and a large hostile concentration in the battlefield was in process of being effected.

The only offensive action taken by the Germans during this period in this area occurred on April 15, when they attacked the British position from Hermies to Noreuil with 16 battalions. An initial success, in which some of the British battery positions were overrun, was at once neutralized by a counterstroke which restored the line.

On April 16 the French launched their main offensive on the Aisne. The decisive results which had been looked for were not achieved; there was no rapid break through or exploitation by a reserve army of manoeuvre. On the contrary, ragged fighting took place which continued until May 5, and the French armies, worn out by more than two years of heavy fighting, were in no condition to sustain an exhausting offensive. The unified command was in the hands of a French general who had planned and conducted operations which proved to be unsuccessful. From April 15 to May 5 the British continued their operations on the Arras-Vimy front at the request of the French and in order to carry out the rôle of absorbing the enemy's reserves. During this period attacks were executed by the British on April 23 and 28 and on May 3 and 5, with the result that the line was pushed forward to include Quemappe-Gavrelle and Arlicux, and some 6,000 additional prisoners and 50 guns were taken. On May 5 the great offensive operations on the Aisne and Scarpe were brought to a close, and on May 15 Gen. Nivelle was relieved of his command. This brought to naught the effort to obtain unity of command, and the operations provided a warning as to the dangers involved where armies of different nationalities are concerned.

Such was the story of a great and successful British effort under conditions of abnormal difficulty. The Russian Revolution had declared itself, the French armies had broken down, the enemy was recovering his reserve power, and the period of the year was getting late for the transference of operations elsewhere. The British field-marshal commander-in-chief then decided immediately that it was necessary to continue on the offensive and to transfer the theatre of operations to the north.

(H) THE RELIEF OFFENSIVE IN FRONT OF LENS.—The great British offensive in Flanders was launched on July 31 1917 and continued to be pressed throughout the autumn. Towards the middle of Aug. a slight improvement took place in the weather, and advantage was taken of this to deliver the second attack E. of Ypres. As it was desirable to prevent the enemy from weakening the remainder of the front so as to effect a greater concentration in Flanders, it was desirable and even necessary to threaten and undertake operations of a minor character at various points to pin the enemy's reserves. A highly successful operation was carried out in the neighbourhood of Lens, and the threat to this town undoubtedly had the effect of preventing the enemy from concentrating the whole of his attention and resources on the main battle-front.

At 4:25 A.M. on Aug. 15 the 1st and 2nd Canadian Divs. attacked on a front of 4,000 yd. S.E. and E. of Loos. The objectives consisted of the strongly fortified Hill 70, which had been reached, but not held, in the battle of Loos in Sept. 1915, and the mining suburbs of Cité Ste. Elisabeth, Cité St. Emile, and Cité St. Laurent together with Bois Rasé and half Bois Hugo. The observation from Hill 70 had been very useful to the enemy, and in the possession of the British, would materially increase their command over the defences of Lens. Practically

the whole of these objectives were gained rapidly at light cost, and in exact accordance with plan. Only at the farthest limit of the advance a short length of German trench W. of Cité St. Auguste resisted the first assault. This position was again attacked on the afternoon of the following day and captured after a fierce struggle lasting far into the night. A number of local counter-attacks on the morning of Aug. 15 were repulsed, and in the evening a powerful attack delivered across the open by a German reserve division was broken up with heavy loss. In addition to the enemy's other casualties, 1,120 from three German divisions were captured by the British. Thus not only was the British position improved but three German divisions, which might have been used in *roulement* on the Flanders front, were severely handled, and the enemy received a lesson which would prevent him from unduly weakening the defensive fronts.

(I) THE BATTLE OF CAMBRAI (Nov.-Dec., 1917).—The repeated attacks delivered by the British in Flanders over a period of more than three months had brought about a large concentration of the enemy's forces in that area, with a consequent reduction of his strength and garrisons in other sectors of his front. The British object in the operations at Cambrai, which took place on Nov. 20 1917, was to gain a local success by a surprise attack at a point where the enemy did not expect it, and on a front which had already been weakened, and thus disarrange the enemy's plans of withdrawing troops from France to operate in Italy. The sector opposite Cambrai had been carefully selected as the most suitable. The ground there was, on the whole, favourable for the employment of tanks which were to play an important part in the enterprise. If, after breaking through the German defence systems on this front, the high ground at Bourlon could be secured and a defensive flank established facing E., and opportunity should be created of exploiting the situation towards the N.W., the capture of Cambrai itself was subsidiary.

As a result of the pressure in Flanders and the Russian Revolution, large German forces had already been brought from the Russian front, partly in exchange for exhausted divisions and partly as additional reinforcements. Moreover, it was certain that heavy German reinforcements would continue to be railed to the western front during the winter. These troops would be largely utilized to strengthen the weakened sector, and if the opportunity, which existed, to deliver a surprise attack at an early date under favourable conditions were not taken advantage of, it would certainly lapse. Against this argument in favour of immediate action must be weighed the fact that the conditions of the Flanders struggle had severely taxed the strength of the British forces, and that the losses, which had not yet been made good, had been heavy.

On the other hand the resources required for the operation were not great, seeing that the force to be employed must be small, for, owing to the requirements of surprise and secrecy, any considerable concentration of troops would be impossible to maintain. The success of the enemy's operations in Italy, too, added force to the arguments in favour of undertaking the operation; although the means available had been reduced by the despatch of troops to the Italian front, the situation on that front was critical, the Italians having been driven back between Oct. 24 and Nov. 10 from the Isonzo to the Piave.

After consideration of these factors, it was decided, by the British command, to undertake the operation, and the execution was entrusted to the III. Army. The general plan of attack was to dispense with previous artillery preparation, and to depend on tanks, of which there would be nearly 500 available, to break down the enemy's wire and cover the infantry advance. No previous abnormal artillery fire was to take place and no registration of guns or any action which might indicate to the enemy that an attack was impending. The infantry was specially trained to work in combination with tanks, and the whole operation depended for success on secrecy and on bold, determined and rapid action.

The German defences on the selected front between Vendhuille on the Scheldt canal and the river Sensée comprised the three

systems constituting the Hindenburg Line (greatly improved during the course of the year) with fortified posts in advance, such for example as La Vacquerie and the north-eastern corner of Havrincourt Wood. Behind this again were two other defensive lines known as the Hindenburg Reserve Line and the Braeuvrevoir-Masnières Line. That portion of this front which lies between the Scheldt canal and the Canal du Nord offered an opportunity for a tank drive to the N. which would include the capture of the important position about Bourlon. The full force of tanks together with five divisions (12th, 20th, 6th, 51st, 62nd) and a portion of another (36th) were allotted to this front extending from Gonnelleu on the right to Havrincourt Wood on the left. Two divisions were, moreover, to be held in reserve behind this front ready to move forward, and the cavalry was to be at hand ready to exploit a success towards the N. and turn the enemy's defences from the rear. In order to make the front of attack more imposing, to deceive and hold the enemy, gas and smoke attacks, dummy attacks with dummy tanks, artillery fire, raids and subsidiary attacks were to be carried out on an extensive scale both on southern and northern flanks.

All preparations were carried out with the greatest secrecy, and during the evening prior to the battle troops and tanks were moved forward into positions of assembly, great care being taken to muffle the noise to the utmost. This was rendered particularly difficult owing to the hard and frosty weather. Each tank was provided with a compressed brushwood fascine some 8 ft. in depth, for the purpose of assisting it in crossing the main Hindenburg trench, which was of abnormal dimensions.

At 6:20 A.M. on the morning of Nov. 20 1917 the tanks and troops moved forward to the attack on a front of about 6 m. from E. of Gonnelleu to the Canal du Nord opposite Hermies. At the same hour the subsidiary and feint attacks took place. On the principal front of attack the tanks rolled on, protected by a smoke barrage from the enemy's artillery. The Hindenburg Line was rapidly overrun. The 12th Div. after severe fighting at Lateau Wood captured the Bonavis spur. The 20th Div. captured La Vacquerie and stormed Welsh ridge, while the 6th Div. entered Ribecourt. The surprise was complete, and the enemy surrendered in considerable numbers. The 29th Div. which had been in reserve moved forward and, passing through the 6th and 20th Divs., entered Masnières and captured Marcoing and Neuf Wood, securing the passages of the canal at both villages and the bridge intact at the latter. In this neighbourhood it was not possible to enlarge the footing gained on the E. bank of the canal, owing to the arrival of hostile reinforcements in the neighbourhood of Rumilly where severe fighting took place.

Meanwhile the 62nd and 51st Divs. attacked the Flesquières ridge, the latter being stubbornly opposed and seriously delayed by the defence of that place. The 62nd Div. however pressed forward and captured Graincourt, its advanced troops entering Anneux. Flesquières continued to hold out throughout the day against the 51st Div., but troops of the 6th Div. entered Noyelles before nightfall. But for the delay at Flesquières and the destruction of the bridge at Masnières the operations would have been completely successful, and would have opened up a great field for exploitation on the following day.

On the morning of the 21st the attack was resumed. But little progress was made on the Masnières-Rumilly front. Farther W the village of Flesquières, turned from the N., fell at 8 A.M., and the 51st and 62nd Divs. with tanks and cavalry moving rapidly forward captured Cantaing and Fontaine-Notre-Dame, and reached the southern edge of Bourlon Wood. Throughout the day infantry and cavalry were heavily engaged at Noyelles. On the extreme left the 36th Div. cleared the Hindenburg Line as far N. as Moeuvres.

By the evening of the 21st the British had gained possession of the Bonavis spur, a bridgehead E. of the Canal de l'Escaut including Masnières and Noyelles, the whole of the Flesquières ridge and the ground to the N. as far as the southern edge of Bourlon Wood including Cantaing and Fontaine-Notre-Dame.

It was now nearly 48 hours after the commencement of the attack, and hostile reinforcements might be expected; at the same time it was necessary from the lie of the ground to decide whether to go on and attack the heights of Bourlon or to withdraw to the Flesquières ridge. Owing to the importance of the possession of the Bourlon heights and the visible signs of withdrawal of the enemy, having regard also to the situation in Italy, it was decided to proceed with the attack.

On the 22nd, while the British were carrying out reliefs with a view to the prosecution of the attack, the enemy recaptured Fontaine. On the 23rd the 40th Div. with tanks attacked and captured the whole of Bourlon Wood, but the attempts to secure Bourlon and Fontaine, after a severe struggle, failed.

The struggle for Bourlon resulted in several days of fierce fighting. On the morning of the 24th the Germans counter-attacked and were repulsed; in the afternoon the British attacked, captured the village and beat off a counter-attack, but the resistance on the Fontaine-Bourlon-Moeuvres front was very considerable. On the 25th and 26th the enemy again counter-attacked in force and succeeded in recapturing Bourlon and the wooded spur between that place and Fontaine. The situation in the wood was now somewhat difficult; on the 27th an organized British attack succeeded in improving the position in the wood, but the troops which at one time had entered Bourlon and Fontaine were obliged to fall back again.

During the 28th and 29th no attacks took place, the troops which had been heavily engaged were relieved, and on the whole front efforts were made to strengthen the position gained. During the ten days' fighting 10,500 prisoners and 142 guns were taken, but the main objective, the Bourlon locality, which would turn the whole of the enemy's positions S. of the Sensée canal and river Scarpe, had not been secured. This was primarily due to the initial failure at Flesquières village.

In the last days of Nov. signs were not lacking on the whole of the front between Vendhuile and Bourlon that the Germans intended to regain the positions which they had lost. On the whole of this front they had carried out artillery registration, but the importance of Bourlon to them and the massing of their troops indicated that their main attack would be delivered on the Bourlon front.

Measures were taken accordingly by the British command; this front was strengthened, while five divisions were disposed on the right flank from Cantaing to the Bateux ravine. Farther S. the original front was held as before, the frontage being wide for the number of troops available. The Guards were in reserve about Villers Guislan, the 62nd Div. on the Bapaume-Cambrai road and the 61st Div. assembling in rear, while four cavalry divisions were available in the neighbourhood. Practically all these troops had already been heavily engaged. All troops were warned to expect an attack.

On Nov. 30 the Germans attacked about 8 A.M., delivering their main assault, as anticipated, on the Bourlon front, and a subsidiary attack on the Cantaing-Vendhuile front. The former was successfully repulsed after the most severe fighting, but on the Bonavis spur and in the direction of Villers Guislan the Germans made rapid progress. On this latter front their attack was in the nature of a surprise assault, without any previous bombardment, but accompanied by a hail of gas and smoke shells and bombs. Villers Guislan, Bonavis, Gonnelleu and Gouzeaucourt rapidly fell into their hands, but their advance was stayed by the resolute action of the Guards, assisted by tanks, which resulted in the recapture of Gouzeaucourt and part of the ridge between that place and Gonnelleu, while the troops holding La Vacquerie succeeded in keeping their opponents at bay. Meanwhile on the N., from Fontaine to Moeuvres, the enemy's main assault, delivered between 9 and 10 A.M., and preceded by a heavy bombardment, was repulsed with heavy losses and at close quarters. This assault was repeated during the morning and afternoon, but all attempts of the Germans to gain any important success either on this front or about Masnières failed completely. On the following days, Dec. 1, 2 and 3, there was severe fighting in the open in the

Gonnelleu neighbourhood, with the result that the Germans progressed in the direction of Villem Plouich, capturing the hamlet of La Vacquerie and thus rendering the position of the British troops defending Masnières and Marcoing extremely precarious. Further fighting continued during the next few days, but the Germans' strength was exhausted and their losses had been severe.

It now became necessary for the British command to decide whether to embark on another offensive battle on a large scale, or to withdraw to a more compact line on the Flesquières ridge. Although this decision involved giving up important positions won with great gallantry, withdrawal was undoubtedly the correct course under the conditions. Accordingly on the night of Dec. 4-5 the evacuation of the positions N. of the Flesquières ridge was commenced, and on the morning of the 7th the withdrawal was completed successfully without interference from the enemy. Captured guns and material which could not be removed were destroyed.

The new line taken up corresponded roughly with the old Hindenburg Line from N.E. of La Vacquerie, N. of Ribecourt and Flesquières to the Canal du Nord  $1\frac{1}{2}$  m. N. of Havrincourt, i.e. about 2 to 2½ m. in front of the line held on Nov. 20 at the commencement of the operations.

These operations undoubtedly had a direct influence on the Italian campaign, by diverting reinforcements and suspending operations at a critical moment when the Allies were making their first stand on the line of the river Piave.

In the offensive it had been hoped by a powerful tank attack and surprise to break and turn the enemy's defences where he was least prepared, and thus create a favourable tactical situation which would place him at a great disadvantage. The failure to secure immediately the Bourlon locality was responsible for the inability to create such a situation, and this was due to the accident at Flesquières, where one German officer handling a field gun put a number of the attacking tanks out of action by direct hits. Success had been very nearly complete.

During the whole of these operations the French were prepared to cooperate with a special force which had been brought forward in readiness, should an opportunity have occurred for exploitation. These troops, with the exception of a few guns which were utilized for defensive purposes, subsequent to the German counter-offensive, were not brought into action and were eventually withdrawn.

These operations in the neighbourhood of Cambrai should be regarded as an incident in the great four and a half years' battle—a surprise stroke followed by a rapid counterstroke—in which although the British did not achieve their tactical object, the balance of advantage remained to a large extent in their hands. The Germans, though successful in their counter-offensive, were apparently not so successful as they had hoped to be.

The main objects of the attack had been attained. The initiative was retained and the enemy's plans deranged. German reinforcements were prevented from being despatched to the Italian front. The enemy had also been prevented from delivering an attack on the French front, which would undoubtedly have produced disastrous results. (J. H. D.)

**ARTS AND CRAFTS** (see 2700).—As the "Arts and Crafts" movement grew out of impulses deeper than were, perhaps, apparent in its first artistic issues, it has continued to react in other directions. In the domain of general education its enlivening influence has helped to insure the full recognition of handwork, an educational medium that was in some quarters tending to lapse into a mechanical exercise, as a most fruitful means of artistic expression. This most important development was a reflection of the art workers' direct efforts in education, which aimed at a complete reorganization of the technical and artistic training of young artisans on lines that were, in effect, a revival, so far as was compatible with modern conditions, of the ancient, well tried system of master-craftsman and apprentice. Although not actually the first to put these principles into practice the Technical Education Board of the L.C.C.

(whose functions are now absorbed by the London Education Committee) was the first public body in England to establish a school solely for this purpose. The Central School of Arts and Crafts, opened by the L.C.C. in 1896, at first under the joint direction of Sir George Frampton and Prof. W. R. Lethaby, afterwards under the latter alone, began the combined teaching of designing and making, of craftsmanship in the fullest sense of the work, in workshops specially equipped for the production of finished work of the finest type. The methods originated in the Central School were soon adopted in other places; new schools and classes rapidly sprang up in London and elsewhere, and students from the colonies, from almost every European country, from the United States and Japan, carried its influence abroad. In 1900, when the Board of Education reorganized the training of teachers for State-aided schools of art, the courses for the diplomas in design and handicrafts at the Royal College of Art, South Kensington, had been taken over, in addition to his other responsibilities, by Prof. W. R. Lethaby. The students of the college, now trained in the practice of various crafts, have, as principals or teachers of provincial schools, infused a new spirit into the study of design wherever they have gone. In the field of art education the genius, knowledge and enthusiasm of Prof. W. R. Lethaby, follower of Morris, and one of the most prominent figures in the arts and crafts movement, have been factors of far-reaching influence.

**Organization.**—Although the activities of craftsmen were necessarily restricted, or diverted into unusual channels, during the greater part of the ten years from 1910-20, the period as a whole showed progress in many directions. Local organizations held exhibitions in most of the great cities of the United Kingdom and Ireland, and in many smaller centres. These, together with the steady growth of groups of workers associated, together in the practice of some particular craft, or crafts, and the ever-increasing number of skilled individuals, greatly multiplied facilities for the exhibition, sale and purchase of, attractive, serviceable goods. Much new work came to the Arts and Crafts Exhibition Society, the parent body, whose periodic shows fulfil a useful purpose in maintaining a high standard of current effort—their main object. The exhibitions, of the Home Arts and Industries Association, an amateur forerunner of the arts and crafts movement, whose voluntary workers organize classes in village crafts, of the Women's Guild of Arts; and those of the more recently established National Federation of Women's Institutes, amongst others, have done useful work within their various, more restricted spheres of action.

The tenth exhibition of the Arts and Crafts Society, held in the New Grosvenor Gallery in 1912, continued in the form made familiar in previous years, gathering together into convenient focus a varied assortment of the best achievement of the day. This in some measure prepared the way for a new and important departure. In 1913 the then recently established Exhibitions Branch of the Board of Trade included arts and crafts in the British section of a foreign international exhibition for the first time. The section organized by the Board at Ghent may be said to have recognized the value of the movement as a national asset, and to have introduced officially work of the kind usually seen in London to a European public. Here an attempt was made to unite the various exhibits into a concerted scheme, and to place different groups of crafts in definite relationship to each other. A temporary building, of striking design, the work of Henry Wilson, the distinguished architect and metal worker, contained part of the exhibits. These changes showed the way to new methods of arrangement, and a more interesting form of setting, which were developed still further in future exhibitions. So great was the success of this venture that in the following year a great part of the collection, the best and most extensive that had yet been brought together, was, on the invitation of the directors of the Louvre, transferred to Paris. The special exhibition of British arts and crafts opened by the Board of Trade in the spring of 1914, in the Pavillon de Marsan of the Palais de Louvre, the home of the Musée



des Arts Décoratifs, was a second edition of the Ghent display, set out in a way that added much to its interest and value. Historic masterpieces of the great pioneers of the 19th century, fine examples from former London exhibitions, and new work that had not previously been shown combined to give a review of the growth of the British arts and crafts movement that was of unparalleled interest. The architectural setting, again due to Henry Wilson, adapted the magnificent galleries to their new purpose with complete success. The attainments of British craftsmen, the directness and novelty of their designs and the quality of their workmanship, shown to a public that had not yet seen any considerable collection of British work of this kind, gained enthusiastic appreciation. In Aug. 1914 the exhibition was hurriedly dismantled, and, as it was impossible to return the exhibits to England, the collection remained buried in the cellars of the Louvre until the end of the World War.

In the autumn of 1916 the Arts and Crafts Society held an exhibition at Burlington House by the courtesy of the Royal Academy, and this helpful interest brought the two bodies together most happily for the first time. A room devoted to a small but representative assemblage of earlier work continued an inspiring feature of the Ghent and Paris shows, including much, now in private hands, that, although well enough known in certain circles, had not been seen by a younger generation. These examples included some of the varied productions of Walter Crane (1845-1915), the first president of the Society, and of William Morris, D. G. Rossetti, Ford Madox Brown, Edward Burne-Jones, and others of the same school, and bore witness to the remarkably versatile genius of those times. Innovations in the arrangement of the exhibits, inherited from the European ventures, and daring developments of the decorative setting of the exhibition that displayed the enterprise of the designer, the new president, Henry Wilson, and the skill of the constructor, Francis W. Throup, brought an unwonted liveliness into the Academic precincts. A series of large paintings in temporary architectural surroundings completely masked the walls of several galleries. Conspicuous in this practical expression of the revived interest in mural decoration were adventures in work of unusual scale by Augustus John, William Rothenstein, Charles Sims, George Clausen and Maurice Greiffenhagen, to mention but a few of the many well-known painters who took part in the most imposing experiment of the kind yet attempted. A series of rooms were erected, decorated and completely furnished by groups of craftsmen, and appropriate collections were brought together in illustration of "University," "Ecclesiastic," and other types of work. A particularly encouraging feature was the number and quality of exhibits by young workers, for the most part students in schools of arts and crafts. Groups of students working under the direction of their masters also took part in the decoration of the galleries, a new departure in collective education that should bear good fruit in the future.

**Relation to Industries.**—In this exhibition a room was set apart for a small display of articles of everyday use of a kind hitherto unrepresented in the Society's shows, arranged by the Design and Industries Association, a body that had been recently formed to better the quality and fitness of goods on sale to the general public through the usual channels of supply. This Association pays but little regard to the long-standing feud between handwork on the one side, and machine and scientific production on the other, but aims at securing an increased output and sale of all kinds of products of the best possible quality. By means of its well produced publications, able lectures, and instructive exhibitions the Association has gained considerable influence all over the United Kingdom, and has succeeded in banding together in close cooperation a number of designers, craftsmen, manufacturers and distributors. It was becoming more and more apparent that continental manufacturers were gaining great advantage from the ideas of British designers—indeed in some cases more than were the British themselves. The British manufacturer and designer had come to regard each other with a certain amount of suspicion; the one had no use for the "long-haired artist," who in his turn mistrusted the standards of design of the other. Foreign observers, especially in Germany, were taking deep interest in the British arts and crafts movement, and reaping very practical results from the knowledge they had gained. So thoroughly were these investigations being carried out that at least one German university had established a professional chair for the

special study of the economics of arts and crafts. Foreign goods that embodied the designs and ideas of British craftsmen were securing an ever widening market, not only abroad, but also in England. As a case in point the history of English influence on German printing is interesting. Several German type foundries cut "punches," based on the calligraphy of Edward Johnston and sold "strikes" (i.e. matrices) to English letter foundries, who gave the type English names in blissful ignorance that the designs were of English origin. The Design and Industries Association deals with the whole question of production and distribution and endeavours to bring together all concerned in an attempt to attain high standards of work and to promote their common interests. Its small exhibit at the Royal Academy, which illustrated a new point of view in artistic design and manufacture, aroused an interest which has been maintained by other exhibitions of the same character. Another "side show" included pottery, printed fabrics and other things made at the Omega workshops. This small selection of the work of Roger F. Fry gave an illustration of his very novel designs, and was a piquant demonstration of the catholicism of the selection committee of the Society.

Encouraged by its success in introducing the products of British craftsmanship to foreign buyers, the Board of Trade determined to extend its efforts so as to include all possible markets, at home as well as abroad. In conjunction with the Board of Education it founded, in 1920, the British Institute of Industrial Art, with Sir Hubert Llewellyn Smith as chairman. One of the chief means by which this new body proposed to further its objects was the establishment in London of a current exhibition of modern British work, representative of a high standard of quality, and of the latest developments in industrial art. It also undertook the organization in the provinces and abroad, of special temporary and travelling exhibitions of the same character, either independently or in cooperation with the Board of Trade, or other bodies. In addition to these activities it has established a bureau of information on all questions relating to industrial art and to British and foreign markets. It proposed to establish a purchase fund with the object of securing for the State selected modern work of outstanding merit. All work intended for exhibition comes before a selection committee, of which one section is devoted to manufactures, i.e. multiple production by hand or machine, and another to the work of individual craftsmen. A number of experts in the various matters that form the business of the Institute were elected fellows, and several exhibitions were held at the galleries of the Institute in London.

This brief summary of the chief recent developments in the organization of craftsmen shows an extension of the scope of the arts and crafts movement far beyond that accepted by the original workers. It is perhaps doubtful whether the pioneers of the last century, with their instinctive mistrust of machinery and commercial production, would have welcomed all these modern innovations with enthusiasm. But however commercial the tendencies of "industrial art" may appear, they have been brought about by the inevitable force of economic responsibilities—responsibilities that are in a measure the heritage of success. The new organizations are broad and elastic; they necessarily included all sincere workers who set themselves high ideals of design and workmanship. The labours of these are, indeed, the basis of their operations, which tend, not to supplant handwork or eliminate the artist, but to widen his sphere of action by giving him his proper place in the control of machine-made things.

**Calligraphy and Illumination.**—The present renaissance of writing is due entirely to the perfectly equipped efforts of Edward Johnston, who, in the latter years of the last century, took up with rare persistence the study of the materials and methods of the great scribes of the past, and produced a number of MSS. written in a hand based on traditional usage, but quite suited to modern needs. As a teacher he gathered around him a band of students, of whom several specialized in writing, and as calligraphists, and, in their turn, teachers, spread his methods far and wide. From this beginning arose the remarkable revival of fine formal writing, inscriptions, and lettering that is one of the most interesting signs of the times. Since 1910 Johnston's work has been frequently exhibited in many places, he stands without rival as a really great scribe. His MSS. addresses, and inscriptions, decorated with initials and ornaments in gold and colour, are highly prized. Graily Hewitt, a distinguished pupil of Johnston's, follows closely in his footsteps with work that is widely appreciated. He is also a teacher of authority and has given attention to the training of children; for whose instruction he has written some attractive copybooks. H. Lawrence Christie is a calligraphist whose inscriptions and MSS. show fine style, and A. E. R. Gill is the most distinguished figure in the long-neglected field of lapidary inscriptions. In the illumination of MSS. and printed books no finer work has been done in recent times than that of Mrs. Sydney Ceckereil. Her designs show a vivid poetic imagination; they are quite modern in character, absolutely without trace of the archaic mannerisms that many workers in this art affect. Exquisite in drawing and colour, her decorations unite harmoniously, not only with the written or printed page, but also with the spirit of the author whose work she decorates. Mrs. Louise Lessore Powell has enriched a number of MSS. with great delicacy and charm. The accomplished illuminations of Allan F. Vigers, based on a most

vibrant study of birds and flowers; have a delightful brightness of colour and design. His ornaments for the Cape Town memorial of the South African War, written by Graily Hewitt, were interesting examples of his work in another vein.

**Printing.**—During the earlier years of the century book production made remarkable advances. The books issued by the Doves Press, founded in 1900 by T. J. Cobden-Sanderson and Emery Walker, were rapidly taking a place as the sole possible rivals of the classic products of the Kelmscott Press, to the excellence of which the expert knowledge of Emery Walker had paid its contribution. The Ashendene Press books, printed by C. H. St. John Hornby, and those of Charles Rocketts's Vale Press, were also increasing the reputation of British printing. In the trade generally a new activity was apparent; fine examples of books, and type of good design were closely studied by publishers and others, who had formerly paid but little attention to matters of this kind. The best British work gained the highest esteem wherever good printing found favour. In Germany, books based upon British models, or even produced under the supervision of authorities such as Emery Walker and Douglas Cockerell, showed how the genius of British printers and binders was growing in foreign appreciation. No trade, however, felt more severely the stress of the years of war; no new press of outstanding merit arose to range its products with the earlier triumphs of the century. An edition of the *Odyssey* was issued by the Oxford University Press, printed in the Greek type designed by Robert Proctor (1868-1903); and a new font, designed by Herbert P. Horne (b. 1864), was used by the Riccardi Press. The old-established Chiswick Press maintained, under Charles T. Jacobi, the reputation that earned for it a worthy place in the revival of fine book work. Technical education in book production was developed in a special department of the Central School of Arts and Crafts under the supervision of the leading members of the trade. Under the instruction of J. H. Mason, an authority on printing, and of a binder, Peter McLeish, the students produced books of quite extraordinary merit, and gained in a few years a very complete introduction to the whole field of book production, passing on, after specializing for a period as either printers or binders, into printing offices and workshops with a foundation of craftsmanship and design of most satisfactory breadth.

**Bookbinding.**—An ever-increasing number of well-bound books, plainly or elaborately finished, bore witness to the improved taste and high standard of craftsmanship to which bookbinding had been brought. In Paris were shown some of the rarely exhibited volumes of T. J. Cobden-Sanderson, the first of the modern binders to bring back into use so much of the tradition of sound workmanship that was giving place to untrustworthy expedients. Practical qualities resulting from good craftsmanship, combined with brilliant richness of design, made all his books specially remarkable. His pupil, Douglas Cockerell, exhibited much admirable work, with decoration of distinction. As a teacher he had, perhaps, more direct influence upon the bookbinding trade than any other worker. Sound methods fortified by much original research into the qualities of materials were, through his teaching, handed on to many skilful pupils, amongst whom may be named F. Sangorski (1875-1912) and his partner G. Sutcliffe, and Charles McLeish, the younger, who inherited much of his father's skill. Cockerell's careful study of "library" binding, suitable for everyday use, was specially serviceable to collectors of books. In the conservative restoration of ancient books his patient craftsmanship and wide experience gave a new lease of life to many priceless volumes in public and private libraries. Queen Mary lent for exhibition in Paris a beautifully bound copy of the reproduction of the *Psalter of Queen Mary Tudor* printed by C. H. St. John Hornby at the Ashendene Press. This binding, designed and executed by Katharine Adams, together with others from the same hand, showed the delicate tooling and clear, restrained designs of this gifted worker, who takes a unique place amongst modern binders. A further selection of her work, including a magnificent volume lent by King George, was shown at the Royal Academy in 1916.

**Furniture.**—The almost universal tendency in cabinet-making towards the reproduction of antique models implies a certain regard for traditional forms, but gravely obstructs the development of furniture really suited to present day needs. Overpowered by the craze for "old things," modern designers but seldom attempted to meet practical requirements in a straightforward, logical spirit. The absurdities of Tudor bathrooms, or Adams' kitchen ranges, would not be tolerated nowadays; but, whilst up-to-date domestic engineering is admitted into historic mansions as a matter of course, "period" furniture is still thought fitting for houses of frankly modern design. Some few makers have built up reputations with work of utility and originality. The death of Ernest W. Gimson (1864-1910) removed the most distinguished cabinet-maker of the time. His work of all kinds, and he was a master of many arts, had a pleasant English stamp, and was always his own beautiful solution of some practical problem of use or comfort. No work more soundly made, or directly designed, than his has been produced; wherever it went it raised new standards of taste. Cabinets designed by Prof. W. R. Lethaby, now too rarely seen, had the distinction that marks all his work. Sidney and Ernest Barnely produced attractive furniture of practical design and sound make. Charles Spooner, and

A. Romsey Green, whose cabinet work was often exhibited, were both interesting designers and makers whose work showed individuality and charm. Ambrose Heal gave the name of Tottenham Court Road a new sound to buyers of simply designed, well made things. George Jack became known both as the designer of many rich pieces of furniture and as a most gifted wood carver. He and Frederic Stuttgart have brought new life into the decaying traditions of carved and gilded picture and mirror frames; they also did admirable gesso work, decorated with gold and colours. Many chairs, of new and serviceable design, were exhibited, including good basket-work seats made by Harry H. Peach. Examples of good upholstered furniture, however, were strangely lacking. Few workers appear to have studied closely the essentially comfortable art of upholstery, in which British craftsmen excelled in by-gone times. A wealth of those small articles in which the woodworker always reveals stationery and music cabinets, work boxes, caskets and so on—appeared at all exhibitions. These, with all their many delightful kinds of decoration by means of gesso, inlay, veneers or painting, had much pleasing ingenuity. A good deal of cabinet work enriched with patterns skilfully painted in colours was produced by several workers. Alfred H. Powell amongst them. In J. H. Grace (1838-1919) was combined a designer of furniture and a decorator whose scholarly and refined work was full of sound traditional knowledge.

**Ceramics.**—The death of William de Morgan (1819-1917), the famous potter who made a new reputation as a novelist at an age when most men retire from active work, removed a great figure from the scene. The wonderful display of his work brought together in Paris in 1914 rivalled the glories of early Persian wares, with its fine technique, noble, vigorously drawn decoration, and splendid play of lustre and colour. Bowls and vases of fine character, by Thackeray Turner, were exhibited in Paris and at the Royal Academy, together with specimens of the interesting "Ruskin" ware of W. Howson Taylor, and some of the attractive work of W. Harrison Cowlshaw. A number of excellent vases, some modelled in the forms of amusingly serious birds, by the skilful brothers Martin, were also exhibited in Paris and other places. Alfred H. Powell and his wife, Louise Lessore Powell, decorated many pieces, and sets, of Wedgwood ware, with exquisite designs painted in their sure, clear style. Exhibits by Doulton & Co. must be mentioned, and also the charming little modelled figures of Mrs. Peche. Stables.

**Textiles and Wallpapers.**—The simplicity of house decoration of the present day is in marked contrast to the lavish use of patterns customary in the latter half of the 19th century. It would appear, perhaps, that William Morris, the greatest pattern designer of our age, was himself an adventurer in the two extremes of taste; his own use of the splendid woven and printed textiles and wallpapers that he designed with such apparent ease, set the fashion in one direction, whilst the ascetic cult of whitewash and plain linen seems also to derive from him. The extensive collection of Morris' textiles and wallpapers brought together at Paris included a number of his precious original drawings for these. Their beautiful drawing and colour and noble sense of design, made distressingly apparent the ignorant carelessness of what now passes for pattern designing in so many quarters. A number of designers of fabrics and wallpapers founded their work on well-tried principles. H. Deare followed closely the tradition of Morris. The designs of C. F. A. Voysey showed pleasing originality, and those of Heywood Sumner the stamp of sound style. Metford Warner, first in the production of fine wallpapers, had also the distinction of being the last manufacturer to attach to his wares the names of the many distinguished designers whom his taste discovered and employed. Allan F. Vigers was a careful observer of natural forms, which he treated with well-considered formality. Sidney Mawson is a bold and vigorous draughtsman who leaned towards realism. Joseph M. Doran produced many well-planned, dignified designs. In sumptuous silks and velvets Sir Frank Warner worthily maintained the traditions of the "grand style" of the Venetians and Genoese. Luther Hooper, the historian of weaving, and a master of the intricate contrivances of the loom, was also a brilliant designer. Edmund Hunter produced a great number of distinctive stuffs, of his own design. E. W. Tristram, an excellent designer and draughtsman, and J. F. Flanagan wove interesting fabrics for hangings and upholstery purposes. The beautiful handwoven linens of Annie Garnett became well known; and Katherine Grasett wove fine stuffs of many kinds. Some tapestries were produced at the workshop started by Morris at Merton, and new adventures in this art were undertaken elsewhere.

In Paris and at the Royal Academy were seen the last work in pattern designing of Walter Crane, whose peculiar genius gave such charm to so many fabrics and wallpapers. In Louis Foremae Day (1845-1910) was lost another designer, whose work, well known to the last generation of decorators. His text books on various arts and crafts were the first of their kind, and ran through many editions.

**Embroidery.**—In the particularly feminine art of embroidery many workers experimented in new directions. In one vein the embroideries of May Morris and her fellow workers and pupils, recalling the designs of, or actually designed by, William Morris, Philip Webb (1831-1915) and others of a school that was preeminent in flowing patterns of large scale, have added splendour to many exhibitions during the decade 1910-20. Mrs. Newall, of Fisherton de la Mere, an embroiderer, whose work is of another type, produced a

number of large hangings and other pieces of quite modern character. Her enthusiasm and knowledge trained a large following of pupils. Mrs. Archibald Christie's bed spreads, curtains, and household linens of various kinds, ranging from heavy appliqué work to things of gossamer-like substance, showed a break in yet another direction. They had an attractive touch of the past, springing from a new use of half-forgotten technical methods, rather than from archaic turns of design. The collection of very original samplers and other specimens, by Mrs. Christie and her pupils, illustrating a wide range of stitches, was a novel feature of the Royal Academy exhibition. Mary J. Newell, another distinguished embroiderer, carried out at the Birmingham School of Art some interesting experiments in decorative stitching and embroidery, that, for its effect, relied more upon interest of subject and colour scheme, than upon diversity of texture. Louisa F. Pesel followed Eastern models, in the intricate workings of which she is an expert exponent.

**Metal Work.**—Amongst metal workers Henry Wilson occupied a most prominent place. Equally successful in a great door of bronze, a silver cup or a minute piece of enamelled jewellery, his many-sided genius recalled the versatile masters of the greatest ages of craftsmanship. His bracelets, tiaras, brooches, and other beautiful jewellery, with their delicately modelled figures and rich ornaments, chased, or enamelled in glowing colours, had wonderful brilliance and character. His ecclesiastical work broke entirely with hackneyed fashions, but maintained the great spirit of significant magnificence. The collection of Wilson's work shown in Paris will long be remembered. R. Catterton Smith, another metal worker, silversmith and jeweller, with a wide range of other activities, was an inspiring teacher, he made famous the Birmingham School of Art, of which he was principal. Amongst other silversmiths and jewellers whose work combined sound craftsmanship and distinctive design, J. Paul Cooper and Arthur Gaskin claim special attention. W. Bainbridge Reynolds's varied work showed great individuality and skill. As a designer and maker of fine serviceable things for domestic use W. A. S. Benson became well known. Amongst the remarkable metal work shown in Paris in 1914, the crown, sceptre, ring and sword worn by H.R.H. the Prince of Wales at his investiture at Carnarvon in 1911, had a romantic interest. These, designed and modelled by Sir W. Goscombe John, were made by Messrs. Garrard & Co. The death of Henry Longden (1831-1920) removed a master metal worker of sound taste and wide knowledge, who was one of the pioneers of the arts and crafts movement.

**Stained Glass and Mosaic Work.**—The stained glass of Christopher W. Whall showed a perfect combination of artist and master craftsman. Beautiful drawing, mastery of colour and design, united with sure technical knowledge in work of the highest rank. His rare capacity in training others surrounded him with a group of brilliant pupils, amongst whom Karl Parsons was prominent. Louis Davis was another glass painter who was a thorough master of his craft. Prof. Selwyn Image's glass was dignified in design and fine in drawing. In mosaic the most impressive modern work decorates the vault of the chapel of St. Andrew, designed by Robert G. Weir. In the cathedral at Westminster. This chapel, opened in 1913, is remarkable for the slender arrangement of its rich marbles of its wall decoration, the slender dignity of its exquisite metal screen, its inlaid choir stalls (the work of the late Ernest W. Gimson), and the glitter of its romantic mosaics. It is the most perfect expression of the particular style of decoration adopted in the cathedral that has yet been achieved. The excellence of the mosaics is due to the technical knowledge of Gaetano Meo, and the fine decorative sense of their designer, George Jack.

**Other Crafts** that claim attention include the art of the poster, which may be deemed a temporary form of mural decoration. This became, at the hands of F. Ernest Jackson and his collaborators, a thing of such interest that its evanescent nature is a matter of regret, rather than of satisfaction, as is too often the case. George Kruger Gray designed heraldic work of many kinds, in the finest tradition of an art in which tradition is an essential quality. Cecil Thomas's engraved and sculptured gems and seals were worthy examples of an ancient craft. The modelled plaster work of Ernest W. Gimson, Laurence Turner, Norman Jewson and others was a lively rebirth of what had become a mechanical form of ornament. Several workers in architectural leadwork, rainwater pipe hushings, sundials and other things, derived inspiration from Prof. W. R. Lethaby, and technical knowledge from the researches of Francis W. Troup. Prof. Thomas Okey added to his many claims to fame the distinction of being the best modern basket-maker. The beautiful table glass designed by Philip Webb for William Morris in 1869 and made by James Powell & Sons, which was exhibited in Paris in 1914, showed modern design and workmanship, equaling, if not excelling, anything of the kind produced in the past. The death of Philip Webb, than whom none was more distinguished amongst that small band of great architects that made the latter half of the 19th century a period so remarkable in the annals of domestic architecture, was also a loss to the many lesser crafts in which his commanding genius found expression. Everything he touched, church or mansion, table glass or embroidery, showed the completeness of his knowledge and the stamp of his individuality.

**Art Workers' Guild.**—From its foundation, in 1884, the Art Workers' Guild has been the inspiring and directing force of the

arts and crafts movement in England. At the meetings of this close, but eminently hospitable body, the far-reaching activities of the world of art have been discussed, with the insight peculiar to practical minds, by the most notable workers of the past 30 years, and influenced in a remarkable way. Perhaps the most striking quality of craftsmen is their versatility. They turn readily from one kind of work to another with an ease and certainty bewildering to the spectator. Norman Shaw (1831-1912) and Philip Webb, typical giants of the last generation, were great in several arts, any one of which might have occupied an individual for the whole term of life, and they added to these preëminence in architecture. William Morris himself was not only master of a score of arts, but preëminent in all.

**Bibliography.**—J. W. Mackail, *The Life of William Morris; Arts and Crafts Essays* by Members of the Arts and Crafts Exhibition Society, *Arts Décoratifs de Grande Bretagne et d'Irlande Exposition, Palais du Louvre* (1914); Edward Johnston, *Writing and Illuminating, and Lettering*, Charles T. Jacobi, *Printing*; Douglas Cockerell, *Bookbinding and the Care of Books*; Herbert P. Horne, *The Binding of Books*, George Jack, *Wood Carving*; Luther Hooper, *Hand-loom Weaving*; William Morris, *Some Hints on Pattern Designing*; Mrs. Archibald Christie, *Embroidery and Tapestry Weaving*; Mrs. Archibald Christie, *Samplers and Stitches. A Handbook of Embroidery*; Henry Wilson, *Silverwork and Jewellery*; J. Starke Gardner, *Ironwork*; W. R. Lethaby, *Leadwork*; Christopher W. Whall, *Stained Glass*. (A. H. C. \*)

#### UNITED STATES

The first American arts and crafts society was instituted in 1807 at Hull House, Chicago. The Boston Society of Arts and Crafts was formed a few months later. Following these, societies multiplied rapidly until there was no large city and scarcely a town or village which had not its local group. New York's society dates from 1904, and was for some years affiliated with the National Arts Club and called the National Society of Craftsmen, numbering shortly after its founding between four and five hundred members. Later, ending this affiliation, it took the name of the New York Society of Craftsmen. At Philadelphia a house was fitted up, with individual studios in connexion with the salesroom. Detroit and Milwaukee early developed active art centres, each with its own building, exhibition rooms and classes. Besides these regular arts and crafts societies there grew up many so-called "gift-shops," with or without tea-rooms.

Industries like those of England were instituted from time to time, but did not flourish as well as the cooperative groups. That of the Abnake Rug at Pequaket, N. H., one of the early and most successful, was conducted by Mrs. Albee who originated the patterns from Indian designs, the name being that of a tribe of Indians formerly inhabiting the region. These rugs, made as were the old hooked rugs, were worked by the country women of the neighbourhood in their own homes and paid for by the square foot. As they suited well the "craftsman" style of furniture, they were in great demand, but the undertaking proved too burdensome, and was given up. Similar industries were conducted in Cranberry I., Me., and in the mountains of the south. Industrial and experimental groups were conducted in connexion with colleges, that of Alfred, N. Y., and of Sophie Newcomb College, New Orleans, being successful examples. At the latter a style of pottery was developed, produced by graduate students and sold by the college for them, in which the motifs were taken from the native flora. A similar group in embroidery created some beautiful things in stitchery and appliqué. Semi-commercial enterprises also sprung up which were varied in their plan and output. The earliest and best known is that of the Rookwood Pottery at Cincinnati, Ohio. The Green by Pottery, although for financial reasons short-lived, was most distinctive, as was the Dedham ware. Both of these came from the neighbourhood of Boston, where too was the Paul Revue Pottery, made under the eaves of the very church from which hung the historic lantern. From here came also a heavy ware, suitable for children's use, the decoration of which was done by girls of high-school age, under careful direction, the industry having developed from classes in a girls' club. In New York the Tiffany stained glass and opalescent ware were celebrated. The Hertel looms, also in New York, produced beautiful tapestries and hangings. From Doylestown, Pa., came the Mercer tiles of unusually artistic design and workmanship. The original patterns were taken from the doors of porcelain stoves brought over by the "Pennsylvania Dutch" settlers of that region. These are a few of the most prominent of the many art industries through the United States. The craftsman furniture paved the way for other styles more or less modelled upon it, the furniture of the Erskine-Danforth Co., New York, being perhaps most nearly in line with the spirit of simplicity associated with the arts and crafts idea.

Individual societies, as has been said, sprung up spontaneously, and although there was a kind of freemasonry among them, each

remained independent and unattached. To bring them together and to unify the movement there was formed in Boston 1907, just 10 years after the founding of the first society, a league of handicraft societies, 20 coming together as charter members. In 1912 the National League of Handicraft Societies represented about 40 arts and crafts societies, of which many had a membership well into the hundreds. Its aim was to form a clearing house for the movement and to do statistical and educational work not within the scope of any one society. It supported a travelling exhibition of handicraft which was sent on request to places in which excellent work of this kind could not be seen, and a travelling library of technical works and other appropriate books not so well selected or easily obtainable outside of the great cities. The founding of this league, of itself, indicates the existence of strong and enterprising societies and the strength of the handicraft idea. When in 1909 the American Federation of Arts was formed at Washington, it included the handicrafts as well as the so-called fine arts, and as the handicraft department covered much of the work of the league, the latter was merged, in 1912, into the arts and crafts department of the federation. The American Federation of Arts aimed to organize a federation of all institutions, societies, city and village improvement associations, and school and other organizations in the United States, whose purpose was to promote the study and application of art, and to cultivate public taste. The educational work was along three lines: it sent out travelling exhibitions of work of a high standard, it circulated typewritten lectures pertaining to the arts and crafts; and it published a monthly magazine.

Early in its history the Boston society issued each month a booklet containing an essay upon some craft with other appropriate matter. This was taken over by the National League of Handicraft Societies and published, with a few changes, as the monthly magazine *Handicraft*. In 1909 the National Society of Craftsmen, N.Y., brought out an eight-page folder each month called the *Arts & Crafts Bulletin*. This flourished for two years and then became *The Arts & Crafts Magazine*, published independently at Washington's Crossing, N.J. Both this and *Handicraft* were bought out in 1913 by the *Industrial Arts Magazine*. Meanwhile there had been published in connexion with the craftsmen furniture a distinctive magazine, *Craftsman*, which did a great deal to develop taste along these lines. *The Philistine*, describing the industry at East Aurora, N.Y., helped to spread the Morris idea as a practical one. In 1921 the handicraft idea had no organ of its own except as represented in the *American Magazine of Art* of the Federation.

In 1914 the Art Alliance was formed with the express purpose of bringing together the artist and the manufacturer. Difficult as this appeared at the time it proved its value. The alliance numbered in 1920 1,000 members in the United States and Canada with others in England, France, Germany and in Manila. Manufacturers pay a membership fee of \$50 a year, artist members \$5, on the theory that the former receive the greater benefit. In Dec. 1920 the fifth annual exhibition of the alliance was held in the Bush Terminal Building, New York City, at which 3,400 designs from 34 states were shown; \$2,000 was distributed in prizes by the manufacturers for designs to be used commercially. In accordance with the tendency to amalgamation, four societies—the Art Alliance, the New York Society of Craftsmen, the Pictorial Photographers of America and the Society of Illustrators—united in the spring of 1920 to secure a local Art Centre, or Home of the Arts, in New York City, in which societies, hitherto unrelated, might have common offices, exhibition rooms, meeting rooms, etc., with a dining hall and a certain number of studios. Stock was issued at \$10 a share and in a short time enough subscribed to permit of the purchase of two houses at 65-67 East 56th Street. The Art Centre was formally opened Nov. 1921.

Another evidence of the interest taken in industrial art is the formation of the Industrial Arts Survey, backed by the state of New York, with an office in Cooper Union, New York City. The aim is to investigate the development of the arts in America, especially as compared with those of Europe, in order to stimulate their development. In this the public schools and the School Arts League have aided. Also in this work and especially in the general education of the public the museums all over the country have successfully cooperated. At the Metropolitan Museum of Art, New York City, there was held in Jan. 1921 a remarkable and beautiful display of industrial art, the Fifth Exhibition of Current Work by Manufacturers and Designers. (M. B. E.)

**ARTSBASHEV, MIKHAIL PETROVICH** (1878- ), Russian novelist, was born in South Russia Oct. 18 1878. His family was of Tartar descent, and on the mother's side he was a great-grandson of Kosciusko. He at first followed an artistic career, and attained some fame as a caricaturist, but subsequently began writing short stories, followed by novels. In 1912 he was imprisoned for several months by the Imperial Government as a revolutionary.

His collected works were published in Moscow in 10 vols. 1912-7, and contain—*Razskazi* (Tales), *U podnesenii chertly* (At the Extreme Point, translated into English as *The Breaking Point*, 1915); *Zakon dikarya* (The Law of a Misanthrope); *Revnost* (Jealousy);

*Volna* (War, translated into English 1918 under the same title) and *Sann* (translated into English as *Sensie*, 1915).

**ARZ VON STRAUSSBURG, ARTHUR, BARON** (1857- ), Austro-Hungarian general, was born at Hermannstadt, Transylvania, and served in the infantry and on the general staff. At the outbreak of the World War he was the chief of a section in the Ministry of War, but hurried to the Russian front, where he commanded first the 15th Div., and later the VI. Army Corps. He shared the success of the battle of Limanowa-Lapanov in Dec. 1914, which definitely stopped the Russian offensive, with Col-Gen. Freiherr von Roth (b. at Trent in 18.9). In the spring and summer campaign of 1915 Arz and his corps acted with Mackensen's German army, and fought with special success in the neighbourhood of Przemyśl and in the further course of the campaign captured the fortress of Brest-Litovsk. Appointed to the command of the 1st Army in the summer of 1916, he had as a Transylvanian to defend that country against the Rumanians, whom he, in conjunction with Falkenhayn's German troops, drove back into Wallachia. After the retirement of Conrad von Hötendorf, Arz was appointed by the Emperor Charles chief of the general staff of the Austro-Hungarian armies, the department of operations being conducted under his direction by the able Maj-Gen. Alfred, Freiherr von Waldstätten (b. at Vienna in 1872).

**ASCHE, OSCAR** (1872- ), English actor, was born at Geelong, Victoria, Australia, June 26 1872. Norwegian by descent, he studied for the stage at Christiania. After appearing at the Opéra Comique, London, in 1893, he joined F. R. Benson's company for eight years, playing numerous parts in Shakespearean and old English comedy. He next played Maldenado in Pincro's *Iris* at the Garrick theatre, London. In 1902 and again in 1904 he played in Shakespeare with Herbert Tree at His Majesty's theatre. He began management at the Adelphi at the close of that year, and, with his wife, Miss Lily Brayton, presented *The Taming of the Shrew*, *Midsummer Night's Dream* and *Measure for Measure*. In 1907 he presented Laurence Binyon's *Attila* at His Majesty's theatre and also, *As You Like It* and other Shakespeare plays. Subsequently to 1911 he specialized in the presentation of spectacular Oriental dramas, the best known being *Kismet*, played at the Garrick theatre, London 1911-2, and *Chu Chin Chow*, first produced at His Majesty's Aug. 3 1916 which ran for nearly five years. In Oct. 1921 he produced *Cairo*.

**ASHANTI** (see 2.724).—By an Order in Council dated Oct. 22 1906, the boundaries between the Ashanti Protectorate and the Crown Colony of the Gold Coast, of which the former is the principal dependency, were readjusted and defined with due regard to tribal lands and natural features. For administrative purposes Ashanti has been divided into four provinces: the Central, the Southern, the Western and the Northern, each of which is under the charge of a provincial commissioner. The capitals of the provinces at which these officers have their headquarters are respectively Kumasi, which is also the capital of Ashanti; Obuasi, a considerable town situated upon the Kumasi-Sekondi railway some 50 m. due S. of Kumasi, and the principal centre of the Ashanti Goldfields Corporation; Sunyani and Kintampo. Each province is divided up into districts which are under the charge of district commissioners, who in their turn are aided by a staff of assistant district commissioners. A chief commissioner who resides at Kumasi, and who is assisted, as in former days the King of Ashanti was similarly assisted, by a council of Kumasi chiefs, is immediately responsible to the governor of the Gold Coast for the administration of Ashanti. This post was filled until early in 1920 by Mr (afterwards Sir Francis) Fuller, who was succeeded by Mr. Charles Harper.

As in the days preceding the conquest, the principal tribes, which at that time formed the Ashanti Confederation under the hegemony of Kumasi, are under the immediate rule of their own tribal organizations which, in each case, consist of an *omahene*, or paramount chief, and of a number of *ohene*, or subordinate chiefs, each one of whom is the overlord of a section of the tribe, with minor chiefs and headmen under him. All these posts are filled, when a vacancy is occasioned by the death or the destoolment of their occupants, by men freely chosen by the tribe, or by the section of the tribe over

which they are called upon to preside, the selection being, however, confined to candidates belonging to one or more noble families in which the office of chief is to this extent hereditary. Descent is traced exclusively through the female side; wherefore a chief is succeeded by one of his brothers, by one of the sons of one or other of his mother's sisters, or by the sons of one of his own sisters, but never by any of his own sons. This causes the position of the queen-mother in a tribe to be one of great prominence, and it not uncommonly happens that, when a doubt arises as to the rival merits of two or more candidates for a vacant office, the decision as to which shall be nominated for election by the tribe is submitted to her for determination. The *omankese* and the various *ohens* of each tribe exercise criminal and civil jurisdiction within the tribal boundaries, the extent of such jurisdiction being limited by the orders of the chief commissioner, issued with the approval of the Governor of the Gold Coast. Courts possessing progressively wider powers are presided over by the assistant district commissioners, district commissioners and provincial commissioners; and until recently all capital cases and civil cases of importance were tried and determined in the court of the chief commissioner. Shortly before 1921, however, a post of judicial commissioner was created, which is held by a qualified barrister whose duty it is to try all capital and all important civil cases, and to revise the judicial work of the officers of the administrative staff. Lawyers are not permitted to practise in any of the courts of Ashanti, and the chiefs have taken up a very strong resistant attitude whenever their admission has been mooted. They deprecate action which they believe will cause justice to become expensive and which is calculated to promote ruinous litigation among the tribes, especially in connexion with land disputes.

After the conquest in 1900, the internal peace of Ashanti remained undisturbed, and the decade immediately preceding the outbreak of the World War was marked by considerable progress. The administrative staff was greatly increased, a first-class motor road from Kumasi to Ejura, a distance of 61 m., was completed in June 1912, schools were established by Government at Kumasi and Sunyani to supplement the 24 schools which in 1913 were being conducted by the Basile Mission; and the cultivation of cocoa spread from the colony, where it had already made great progress, into Ashanti.

No idea of the true financial position of Ashanti is conveyed by the published statistics, as the Protectorate is not credited with the customs duties on articles designed for consumption within it, which are collected at the ports of entry on the Gold Coast, nor yet with the revenue derived from goods carried on the Sekondi-Kumasi railway. On the other hand, the main expenditure upon the Gold Coast regiment of the West-Africa frontier force is shown in the accounts as a charge against Ashanti, Kumasi being the headquarters of that corps, though the regiment is no longer even nominally maintained to insure the tranquillity of the local population. In 1913 the total value of the exports from Ashanti amounted to £1,155,378, the items being gold worth £475,089, cocoa worth £400,000, kola nuts worth £126,000, rubber worth £75,209, cattle and sheep worth £45,600 and hides worth £33,480. By the end of 1913 good paths, suitable for bicyclists, had been made and were being maintained by the various tribal organizations throughout the greater part of Ashanti.

In his annual report for 1914, Mr. (afterwards Sir Francis) Fuller was able to record "the unanimous and deep loyalty expressed by all the Ashanti chiefs towards their Sovereign and Government on the outbreak of war"; and so complete was the confidence felt in these sentiments that from Aug. 1914 onward the Government of the Gold Coast was able almost totally to denude Ashanti of troops in order to dispatch expeditionary forces to take part successively in the Togoland, Cameroon and East African campaigns. Ashanti provided few recruits for these forces, the people disliking the military discipline which is so dissimilar to their own methods of warfare, and the spread of permanent cultivation (cocoa) having attached them to the soil to an extent unknown in former times. Their loyalty, however, remained unabated throughout, and the years of the war were marked by great local development.

By the end of 1918 over 380 m. of roads suitable for motor traffic were available, most of which had been constructed by the tribes themselves under European supervision, and large numbers of lorries were at work carrying the cocoa crop to rail-head. The exports in 1919 were valued at £2,433,205 (gold, £421,696; cocoa, £1,425,185; kola nuts, £493,680; rubber, £632; cattle and sheep, £70,000; hides and skins, £7,012; snails, £10,000; miscellaneous £5,000). The value of the imports had risen to £1,773,257, the principal items being European merchandise worth £1,201,237, cattle worth £370,000, sheep and goats worth £100,000 and dawadawa and Shea butter worth £92,000. The quantity of gold exported had slightly declined, but the export of cocoa had risen from 8,693 tons in 1913 to 32,009

tons in 1919, and the increased imports of live stock are due to the enhanced consumption of meat by the rural population alike in Ashanti and in the colony as a result of the wealth consequent upon the spread of cocoa cultivation. Wild African rubber had ceased to be worked. Large numbers of live stock and snails, which are a local delicacy, were reexported to the Gold Coast.

REFERENCES.—D. Kemp, *Nine Years on the Gold Coast* (1898); C. Hayford, *Gold Coast Native Institutions* (1903); Frederic H. Gough, *The Ordinances of Ashanti*, etc., revised edition prepared under the authority of "The Reprint of Statutes Ordinance, 1909" (1910); S. R. B. A. Ahuma, *The Gold Coast Nation and National Consciousness* (1911); L. P. Bowler, *Gold Coast Palaver: Life on the Gold Coast* (1911); C. Hayford, *Gold Coast Land Tenure and the Forest Bill* (1912); H. Waetjen, *Zur Geschichte des Tauschhandels an der Goldküste um der Mitte des 17ten Jahrhunderts* (1915); Reports, Notes of Cases and Proceedings and Judgments in Appeals, etc., and References under Rules, Orders and Ordinances relating to the Gold Coast Colony (1915); C. Martin, *Les Possessions britanniques en Afrique Occidentale* III. Côte de l'Or (Renseignements Coloniales, etc., 1917); T. W. H. Migeod, "Tribal Mixture on the Gold Coast," *Jour African Soc.*, vol. xix, pp. 109-125 (1920). (H. CL.)

**ASHBOURNE, EDWARD GIBSON, 1ST BARON** (1837-1913), Irish lawyer and politician, was born in Dublin Sept. 4 1837, and was educated at Trinity College, Dublin. He was called to the Irish bar in 1860, and in 1872 became a Q.C. In 1875 he was elected for Dublin University as a Conservative, and in 1877 became attorney-general for Ireland in Disraeli's Government. In 1885 he was made Lord Chancellor of Ireland with a seat in the Cabinet, and raised to the peerage, holding the same office in the Conservative Governments of 1886-92 and 1895-1905. Lord Ashbourne took a prominent part in the early negotiations for land purchase in Ireland. He died in London May 22 1913, and was succeeded as 2nd baron by his eldest son, William Gibson (b. 1868).

**ASHFIELD, ALBERT HENRY STANLEY, 1ST BARON** (1874- ), British politician and man of business, was born at Derby Nov 8 1874. He spent his early years in the United States, and was educated at various American technical schools and colleges. He entered a railway office and had a successful business career, becoming general manager of the Detroit United Railways and the Public Service Railways of New Jersey. In 1910 he returned to England, and took up the position of managing director of the traffic combine which included the Underground Electric Railway Co. and the London General Omnibus Co. In 1914 he was knighted. On the formation of Mr Lloyd George's Government in 1916 Sir Albert Stanley was elected to Parliament for Ashton-under-Lyne, being included in the Cabinet as President of the Board of Trade. He was a notable instance of a minister selected as a "business man" and not for any of the usual political considerations. He retained his office until May 1919, when he resigned and was raised to the peerage.

**ASHLEY, SIR WILLIAM JAMES** (1860- ), English economist (see 2 733\*), served during the World War on a number of Government committees, especially with regard to food prices and the cost of living. He was a member of the Consumers' Council appointed in 1918 to assist the Ministry of Food. In 1913 he had been president of the Economic History section of the International Historical Congress, and in 1914 he was one of the authors of the report on Industrial Unrest published by the Unionist Social Reform Committee. In 1912 he published *The Rise in Prices and Gold and Prices*, and in 1914 *The Economic Organisation of England*. He was knighted in 1917.

**ASHWELL, LENA** (1872- ), English actress (see 2,734), at the outbreak of the World War organized a Women's Emergency Corps for rendering services of all kinds to the Allied forces and to refugees, as well as assistance to women at home thrown out of work by the dislocation of industry. She also formed a company of actors and musicians and went with them to France, where they provided excellent and much-appreciated entertainment to the troops when resting. She was made O.B.E. on the institution of the Order of the British Empire Aug 24 1917.

**ASIAGO, BATTLE OF, 1916.**—The Asiago plateau was the scene of various battles on the Italian front during the World War (see ITALIAN CAMPAIGNS), but what is called preeminently

\* These figures indicate the volume and page number of the previous article.

"the battle of Asiago" was that which was fought in the Austrian offensive of 1916, resulting in the first enemy occupation of Italian territory.

An attack from the Trentino with the object of cutting the Italian communications with the Julian front, and so bottling Cadorna's main force in what Krauss calls "the Venetian sack," was an operation which could not but commend itself to the Austrian general staff. In the words of Falkenhayn, who refused his coöperation to the proposal made by Conrad von Hüttenndorff in Dec. 1915, "this project contemplated an operation which must, once at least during the war, have certainly attracted the attention of every general staff officer who took a look at the map of the Italian theatre of war. It was very inviting." Falkenhayn's refusal to join in the enterprise was based on various grounds, his belief in the prospects of success at Verdun; his anxiety regarding the Russian front, and, probably, the idea that a formal state of war between Germany and Italy might still be avoided. He felt, too, that even if the plan were as successful as Conrad claimed it would be, its effect on the general course of the war would not be sufficiently important to warrant the risk taken in detaching a strong German force for the enterprise itself, or for replacing Austro-Hungarian divisions in the east if the actual attack should be left to Germany's ally. Conrad believed that the effect of the attack would be decisive, and Krauss, then chief of the staff to the Archduke Eugene, agreed, but was of opinion that a double attack should be made, on both the Julian and Trentino fronts. Without German assistance it was obviously impossible to collect sufficient forces for this double attack. But Falkenhayn went further, he put the number of troops required for the Trentino attack alone at 25 divisions he doubted the possibility of collecting such a force, and he questioned whether, if it were available, supply could be assured by the limited railway communications leading to the scene of action. Krauss was convinced that an offensive against Italy from the Trentino was practicable, and, if accompanied by a simultaneous attack on the Isonzo front, would lead to great results. He believed that the Trentino operation could be conducted in Jan. and Feb., when the winter snow was frozen hard; before the heavy spring snowfall. It is difficult for anyone who knows the Trentino in winter to admit his contention that this hard snow would resist the passage of troops in mass, not to speak of guns, even if one were to accept his idea of basing the operation on drives through the valleys, on the west of Lake Garda as well as on the east. Conrad does not seem to have considered the idea of attacking till later in the season, and the plan which he put before German headquarters was radically different in idea from that which Krauss favoured.

Conrad's plan was to attack through the Asiago and Arsihero uplands, in the direction of Vicenza and Bassano rather than towards Verona. When he failed to convince Falkenhayn that the effort should be a joint one, he determined to attack independently, and, according to Krauss, he endeavoured to conceal his preparations from the Germans. Perhaps his independent action was a result of Falkenhayn's independent decision to attack at Verdun. Perhaps he wished to avoid further discussion of a project upon which his mind was set, the more so as he was embarking on the enterprise with a force greatly inferior to that which Falkenhayn had considered necessary. Conrad's attacking mass consisted of 14 divisions only.

In view of the relatively small force available, Conrad was compelled to reduce his front of attack. His original intention, apparently, had been to extend it to the north of the Brenta valley, though the main drive was to be to the south. With the troops at his disposal he could not afford this extension, and he made his effort between Rovereto and the Val Sugana (Upper Brenta). It seems obvious that with this limited force, operating in difficult country, Conrad could not have hoped to achieve the more ambitious results which he had urged would follow upon a successful attack from the Trentino. Assuming that he broke through and reached the plain, he could hardly expect to do more. But if his offensive were so far successful, if he had

once cleared the way to the plains—then perhaps the stiff-necked Falkenhayn might change his mind, and take advantage of the opening offered by an Austrian success.

Cadorna's general line of argument, when rumours of attack began to arrive, resembled that of Falkenhayn. He believed he had shut the doors fast against any ordinary attack, and he did not think that Conrad could spare troops for an offensive on the grand scale, or that, if he could, he would make his big effort in the Trentino. Like Falkenhayn, Cadorna thought the railway communications insufficient. He assumed, moreover, that Conrad had reasonably accurate information about the forthcoming Russian offensive and would not risk attacking at such a distance when the Russian threat was imminent. But Conrad hoped to attack sooner than he eventually did, his troops were ready in April, but the snow caused a delay which gave rise to much impatience at Austrian headquarters. He had also persuaded himself that his troops in the east were strong enough to resist any pressure that could be brought against them.

Cadorna was sceptical of an offensive in strength, and thought that the reported movements in the Trentino signified a limited attack, to be undertaken with the object of hampering his offensive towards the east. In the late autumn and winter he had reduced the strength of the I. Army to the minimum in order to strengthen his attack on the Isonzo, and in reply to Brusati's expressions of anxiety regarding the adequacy of his forces during this period Cadorna pointed out that the requirements of the Isonzo front made it necessary to reduce the numbers of the I. Army, and that in the event of a threat developing from the Trentino there would be sufficient warning to allow the reinforcement of the front in good time. He reminded Brusati, on various occasions, that the rôle of the I. Army was strictly defensive. He had already indicated, early in the campaign, the defensive lines to be prepared, and had on various occasions insisted on the necessity of strengthening these lines. During the first few months of the war the troops of the I. Army had advanced at various points beyond the limits laid down by Cadorna, and in these sectors the army was aligned for offensive action. This would not have mattered if the necessary defensive works had been carried out, but the energies of the troops had been directed to preparing elaborate works in advance positions not well suited for defence, and the positions chosen by Cadorna for the main line of resistance were in many cases untouched. Brusati had carried out successfully the initial part of his work, the reduction in length of the Trentino front. The original front of the I. Army, from the Stelvio to Croda Grande (east of the Val Cismon) is close upon 240 mi. in length, but the advances made in the first weeks of the war had shortened the line by over 100 miles. The second part of the army's task, that of fortifying the 70 m. of front which could be considered feasible for the operation of troops in large numbers, had been neglected in certain important sectors.

It was on March 22 that the probability of an Austrian attack was first reported by the I. Army command, whose initial requests were granted at once, the transference of two brigades to the Isonzo front being countermanded, and four additional brigades being placed at Brusati's disposal. In his answering despatch Cadorna repeated the instructions to fall back upon the principal line of resistance in case of an enemy attack. On April 2 Brusati sent a further report upon the concentration of enemy troops in the Trentino, and stated that he had taken the steps which he considered to be most opportune in relation to the means at his disposal. In reply Cadorna detached two more divisions, the 9th and 10th, from the general reserve in Friuli, to be held in reserve at Schio and Bassano, and gave an additional group of Alpine battalions to the I. Army. As a result Brusati wrote, on April 6, that the reserves given him allowed him "to view with complete confidence even the most unfavourable event." Although Cadorna was still sceptical in regard to an offensive in force, he increased Brusati's artillery strength by 18 batteries of middle-calibre guns and gave special orders for the supply and transport of ammunition. On April 7 at Cadorna's request Brusati sent a report upon the defensive



system between the Val Lagarina and the Val Sugana, accompanied by a map showing the various lines, stating that the conditions were "re-assuring," and that the third line of defence upon which Cadorna had laid special emphasis could be considered as being in a satisfactory state of efficiency. Three days later Brusati suggested the reinforcement of two sectors of the line, that between the Vallarsa and the Val Terragnolo, and the Tonezza sector, between the Val Terragnolo and the Astico. He asked for permission to split the 9th Div., which had been given him as a reserve, and send a brigade to each of the sectors mentioned. He also asked for another division to be held in reserve about Vicenza. Cadorna was unwilling to break up the 9th Div., and ordered that it should be held in reserve at Schio, within easy reach of the Vallarsa sector, while to reinforce the Tonezza sector he dispatched an additional brigade from the general reserve. He also detailed the 27th Div., in reserve on the Tagliamento, to be ready as a further reinforcement and formed a further artillery reserve of 10 heavy batteries.

At the end of April Cadorna went to visit the lines in person. He found that while the front lines had been elaborately fortified, in various sectors the reserve lines which he had indicated as the "battle positions" were almost untouched, and parts of the front line were unsuitable for prolonged resistance. Between the Val Lagarina and the Vallarsa and along the Val Terragnolo the Italian lines formed a dangerously exposed salient, running down from the high slopes and completely dominated by the Austrian guns on Monte Biaena, Monte Ghello, Monte Finonchio and the Folgaria plateau. In the Val Sugana the same fault was observable. The forward lines on Monte Armentera and Monte Salubio were poorly adapted for defence, but had been strongly fortified, while the line east of the Maso torrent, which Cadorna had indicated as the main line of defence, had undergone little preparation. Cadorna ordered the positions to be modified. The bulk of the heavy guns were withdrawn to the second line and the work of preparation was hastened on, but the enemy attack seemed imminent, and it was impossible to set about a complete reorganization under the immediate threat.

On the wings it was possible to improve the situation. In the centre the problem was different, for here the Italians were of necessity badly placed. The salient of Soglio l'Aspio (4,375 ft.), between the frontier and the Upper Astico, was practically in the air, and could only be considered as an outpost. But the main line between the Posina and the Astico, which ran by Monte Maggio (5,730 ft.), Monte Toraro (6,175 ft.), Campomolon (6,030 ft.) and Spitz Tonezza (5,512 ft.), was not satisfactory for defensive purposes. It was close under the Austrian guns and it had no depth. Behind the line the ground falls away south-eastward in a steep glacis that drops abruptly in the end to the Posina on the south and the Astico on the east. It was owing to the essential weakness of this line and its extension northward to the west of the Val d'Assa that Cadorna had ordered the preparation of a third line of defence that ran from Cima Portule (7,570 ft.) east of the Val d'Assa and round the southern rim of the Asiago basin by Punta Corbin across the Astico to the mountains south of the Posina. This line was shown as existing upon the map sent to Cadorna on April 21 by the I. Army command. In reality little had been done beyond the tracings on the map. The project had remained a project.

On May 8 Brusati was replaced by Gen. Pecori-Giraldi, the commander of the VII. Corps (III. Army). A few days previously Cadorna had modified the system of commands in the threatened sector. Up to the time of his arrival on the I. Army front the whole line between Lake Garda and the mountains east of the Val Sugana had been included in the V. Corps command (Gen. Zoppi). The Val Lagarina and Val Sugana sectors were now placed under independent commands, and the long line held by the V. Corps was reduced to include only the hill country between the Vallarsa and the eastern edge of the Asiago plateau. On the eve of the Austrian attack the alignment of the I. Army was as follows:—West of Lake Garda the line was held by the III. Corps (two divisions) under Gen. Camerana. The Val Lagarina sector, from the lake to Zugna Torta, was held by the

37th Div. under Gen. Ricci Armani (two brigades, three battalions of Alpini, with several weak battalions of territorial Militia). The Sicilia Bde. was arriving in the Adige valley to act as a reserve. The left-hand division of the V. Corps (the 35th) was in line between the Vallarsa and the Astico, the Roma Bde. right down upon the Val Terragnolo, backed by a territorial Militia regiment in Col Santo and two Alpini battalions holding the Borcola Pass. The Ancona Bde., freshly come into line, lay from Monte Maggio to Campomolon, while the Cagliari Bde. was echeloned forward in the Soglio d'Aspio salient, and a group of Customs Guards battalions held the edge of the Val d'Astico. Two brigades of the 34th Div. and a group of Alpini held the Val d'Astico and a line that roughly followed the frontier as far as Cima Manderiolo (6,665 ft.). A third infantry brigade and two brigades of territorial Militia lay in immediate reserve. The right wing of the army, occupying the Val Sugana sector (extending to the Val Cismon), consisted of the XVIII. Corps under Gen. Etna, three infantry brigades, four battalions of Bersaglieri and six battalions of Alpini. The 9th Div. lay at Schio, ready to reinforce the Vallarsa-Val d'Astico sector, while the 10th Div. was at Bassano, and a group of Alpini was at Marostica. The 44th Div., freshly returned from Albania, was concentrating at Desenzano, and the 27th still lay on the Tagliamento, where the X. and XIV. Corps were also in readiness to leave in case of need. In all Pecori-Giraldi had at his immediate disposal 130 regular battalions, even battalions of Customs Guards and 45 battalions of territorial Militia, the latter at very low strength and of small fighting value. The 44th Div., which was not ready to move at the beginning of the battle, brought the number of regular battalions up to 142. The artillery strength consisted of 851 guns, of which 348 were of heavy or medium calibre and 259 were light guns of position.

The Austrians had a great superiority in artillery, upon which they relied for breaking their way through the Italian lines. Between the Val Lagarina and the Val Sugana were concentrated some 2,000 guns, of which nearly half were of heavy or medium calibre, including 40 305-mm. howitzers, four 380's and two or three German 420's. The attacking force was arrayed in two armies, one behind the other, Dankl's XI. Army in front with nine divisions, von Koevess's III. Army in support, with five divisions. The troops in the Val Lagarina and the Val Sugana were not included in this force, which was to make its offensive between the two valleys, where only supporting attacks were to be carried out. Krauss, as chief-of-staff of the Archduke Eugene, was opposed to the disposition of the two armies and to the limitation of the attack to the hill country. He urged that the front of attack should from the outset be divided between Dankl and von Koevess, and pressed for the adoption of his plan for the concentration of attacking masses in the valleys, especially in the Val Sugana. But the original plan, prepared in all its details by Conrad and his staff, was not modified; it would seem that the Archduke Eugene and his chief-of-staff had little freedom of action. The tactical direction of the attack was entrusted to Dankl, who had at his disposal some 180 battalions.

The offensive opened on May 14 with a very heavy bombardment along the whole line from the Val Lagarina to the Val Sugana; but the concentration of fire was most intense between the Vallarsa and the Upper Astico, and against this sector, the following day, the main infantry attack was launched. The plan was to attack first with the right wing of the XI. Army, commanded by the Archduke Charles, supported not only by his own artillery but by flanking fire from the massed guns on the Lavarone plateau. When the right wing had made sufficient ground the left wing was to come into action against the Italian line in the Seven Communes, north of the Upper Astico. On the extreme right of the attack, between the Val Lagarina and the Vallarsa, the Italians withdrew from their ill-chosen front lines, fighting steadily, and making the enemy pay for the ground gained. In the Val Terragnolo the Roma Bde. was run over by the enemy attack. Many prisoners were taken, and the second line, which was withdrawn in accordance with the general instructions given by Cadorna, came back in some disorder,

Against the forward line between Monte Maronia and Soglio d'Aspio the Austrian attack made no headway at first, the Cagliari Bde. and the Alpini holding firmly to their positions, but in the end the first line was occupied, the Italians retiring to the main line of defence, which ran from Monte Maggio by Campomolon to Spiza Tonezza. The Italian right was so far not heavily attacked, and demonstrative attacks by the Austrians in the Val Sugana were readily repulsed. Cadorna transferred his staff from Udine to Thiene on May 16, and next day he found a critical situation on his left. The Roma Bde., or rather what was left of it, was coming back in the Vallarsa, and Col Santo had been evacuated by the territorials, while the command of the sector had lost touch with the Alpine battalions. In the centre, too, the situation was bad. The Campomolon line was being strongly attacked, and showed signs of yielding, though reinforcements from the 9th Div had been promptly dispatched. The line had been insufficiently prepared, and was being methodically knocked to bits by the very heavy fire of the Austrian big guns. But the chief danger lay on the left, where there was little to stop the Austrian advance between the Vallarsa and the Val Terragnolo. Here, too, practically nothing had been done to prepare the reserve positions, and owing to a mistaken order the retiring troops had not occupied Monte Pasubio, the key position now that Col Santo had gone. The Volturno Bde., of the 10th Div., which was on its way to reinforce another threatened sector, was diverted to the more critical point. A battalion was hurried up in motor lorries, and marched up to Pasubio by the Passo di Xamo. They arrived after a night march, in the nick of time. Two hours later the first Austrian patrols appeared and were quickly repulsed. The rest of the Volturno Bde. followed, and held the position till they were relieved and reinforced by the 44th Division. By May 19 the Austrians were attacking hard all along the line to which the Italians had retired, from Coni Zugna and the Passo di Buole to Pasubio, and the Campomolon line had gone. On May 18 the Austrian attacks, supported by very violent artillery fire, broke the front of the Ancona Bde., and the rest of the 35th Div., threatened on the flank, withdrew during the night. The retreat was covered by the Vicenza battalion of Alpini, who fought a gallant rear-guard action, and a strong counter-attack by the group of Alpini from Marostica checked the Austrian pursuit. The 35th Div., with its reinforcements from the 9th, came back to the line Monte Aralta (south of the Posina)-Monte Cimone-Barcarola, but the Italian centre was now broken. There were gaps both to the right and left of the 35th, though the Alpini were holding north of the Posina and the 27th Div was coming up rapidly to the valley.

It was a critical moment for the defending army. The Austrian right was increasing the pressure against the positions west of the Vallarsa, and was collecting forces for the first of the long series of attacks against Pasubio, which was only lightly held. The 44th Div. was on its way to the front, but had not yet arrived, and a large number of the guns in this sector had been destroyed prematurely, in the belief that retreat was imminent. There was breathing space for a moment in the centre, but the Austrian left now came into action, Krautwald von Annan's III. Corps being launched against the Italian 34th Division. Ample Italian reserves were now on the move, the XIV. Corps being *en route* to fill the gap between the 35th and 34th Divs. and reinforce the latter, but it was a race. Krauss blames the Austrian XX. Corps (Archduke Charles) for waiting till the guns could be brought up to support a new attack instead of driving through at once to Arsiero with all available troops. Perhaps a column, perhaps a strong force, might have pushed straight on to Arsiero and beyond; and if so, it might have gone hard with the Italians. The risk was not taken, and the short respite gave time to close the doors in the face of the invader.

The course of the battle, with the necessity of bringing up reserve divisions, led to a reorganization of the attacking forces, von Koevess taking command of the left wing and Dankl of the right. In the Vallarsa and Pasubio sector the

attack developed strongly. The advance along the ridge from Zugna Torta, which had been throughout stubbornly contested by the Italians, had been definitely checked by a regiment of the Taro Bde. at Malga Zugna, and the Austrians endeavoured to break through by coming up from the Vallarsa against Passo di Buole. At the same time Pasubio was assailed with the utmost determination. Farther north the Archduke Charles was waiting for his guns and for reserves, and between him and the III. Corps Kirchbach's I. Corps was coming into action. The III. Corps was now hammering against the Italian 34th Div., whose position was precarious, and although Etna's Val Sugana troops had held their own against various tentative attacks, they were withdrawn to the second line of defence.

Although the wings were holding, the situation in the centre was very grave, and Cadorna considered that if the Austrians were able to concentrate on the weak spot and keep up the impetus of their attack they might succeed in breaking through to the plain. On May 20 he went to Udine, and after consultation with the Duke of Aosta and Frugoni gave orders for the concentration of a reserve army in the Venetian plain. The movement of these troops, which were placed under the command of Frugoni, began on the night of May 21, by road: the railways were occupied with the transport of I. Army reserves (the X. Corps and various other units), and were not available, till May 26. The first four corps of this reserve army (the V.), which were made up of units drawn from the II. and III. Armies, were ready on June 2.

Meanwhile the Austrians were continuing their advance in the centre, but the situation on the Italian left was improving. By May 22 the 44th Div., commanded by Gen. Bertotti, was in solid possession of both sides of the Vallarsa road and of Pasubio, and in touch with Ricci Armani on its left. The latter was holding firmly on Coni Zugna and the Passo di Buole, and neither here nor on Pasubio could the repeated attacks of the Austrian right make any impression. On May 24 a desperate effort was made to storm the Passo di Buole and Pasubio, but the Sicilia and Taro Bdes., who held the Zugna ridge, and the right wing of the 44th Div. on Pasubio, repulsed the onset with very heavy losses. The columns attacking Passo di Buole suffered heavily from the flanking fire of the 44th Div. guns in the Vallarsa. The left wing of the division was not attacked in force and Bertotti was able to assist Ricci Armani with his guns. Next day the attack was renewed, heavy columns coming up the slopes against the Passo di Buole, only to be thrown back, broken and decimated, one brigade being practically destroyed. The last attack in force was on May 30, when repeated efforts were made to storm the Pass, in vain. Although further attacks were made after this date the fighting never again reached the same intensity. The Austrian losses had been too heavy for them to continue their attacks in mass, and their attempts to advance in open formation were easily checked.

The importance of the defence at the Passo di Buole can hardly be over-estimated. If the Zugna ridge had fallen, the effect upon the Pasubio position, already a salient, would have been more than serious, and upon the holding of the Pasubio lines depended the maintenance of the positions held by the right wing of the V. Corps. On May 22, following upon the retreat from the Campomolon line, the troops holding the lines in the Seven Communes had been detached from the V. Corps, and the command in this sector had been given to Gen. Lequiu, who had come from Carnia. On May 24 the rest of the V. Corps had for the most part retired beyond the Posina or down the Astico to the plain, and had been replaced by the 27th Division. If Pasubio went, the line south of the Posina was turned, and the Austrians had a new route to the plain by the Valli dei Signori, as well as the opening they were now making for, by the Lower Astico. Pasubio was the key of the situation, and the Austrians hammered unceasingly against Bertotti's right wing. The guns never ceased, and a long succession of attacks broke in vain upon the Italian lines. The Austrian infantry advanced along the great ridge from Col

Santa; they came up from Anghelani and Chiesa in the Vallarsa and from the Val Terragnolo by the Borcola Pass. Bertotti had four brigades under his command, including the remains of the Roma, and the 6th Group of Alpini, and he changed his troops continuously. The conditions were very hard, and frost-bite was responsible for many casualties, for the snow still lay deep on the high ridges, but the spirit of the troops was proof against all trials, and it was against the iron lines of Pasubio that the Austrian offensive came to failure.

North-east of Pasubio, along all the rest of the mountain front to above the Val Sugana, the Austrians gained notable successes. The gap between the 35th and 34th Divs. had been filled by the arrival of the 30th Div. (XIV. Corps), and the 28th was on its way, the three Divs. (34th, 30th and 28th) now forming the XIV. Corps under Lequio. But von Koevess's attack had broken through the Italian line in the Seven Communes. For two days the Italian 34th Div. had fought off the attacks of the Graz (III.) Army Corps. On May 21 the order was given to retire to the line Monte Verena-Cima di Campolongo, and the stay on this line was short. Contact was lost with the left wing of the XVIII. Corps in the Val Sugana, and the Austrians turned the right wing of the division by a bold and skilful advance by way of the Porta Manazzo. A retreat was ordered to the Portule line, east of the Val d'Assa, which was supposed to be the principal line of resistance. The 34th was unable to stand on this line. Owing to an error in the transmission of an order the Alpine troops who were holding the positions of Cima Undici and Cima Dodici retired before the Austrians attacked, and uncovered the flank of the division, while on the same day (May 25) the attacking forces succeeded in occupying the important position of Corno di Campo Verde (6,815 ft.). Next day the attack was continued from north and west, and the Italians were swept off the whole line between the Val d'Assa and the Val Galmarara. A number of prisoners and guns were lost, and prospects looked black for the Italians, though the 28th Div. was now coming into action. On May 26 the situation was such that Cadorna thought it wise to make further preparations for a step which he had already considered and planned—a retreat from the Isonzo and Cadore. He ordered all heavy artillery not absolutely necessary for defensive purposes, and all stores beyond the minimum required for immediate supplies, to be withdrawn from the Isonzo front and brought south of Treviso, behind the Silo. With the possibility of a general retreat in view, it seemed necessary to withdraw the heaviest impedimenta in good time. Although Cadorna believed that he could hold back the Austrian attack, he had no intention of omitting any precautions.

The Italian position looked unfavourable and worse was yet to come, but Cadorna's confidence was justified. The impetus of the Austrian attack was dwindling. The effort had been great, and losses had been very heavy. The attacking divisions were beginning to lose their offensive value, and the reserves were insufficient. By May 27 Conrad had been compelled to ask Falkenhayn to send to Italy a division of the Austrian XII. Corps, which belonged to Prince Leopold's Army Group. By the end of the month Cadorna was holding his own, although both Dankl and von Koevess were still making progress.

On May 27 Dankl's left wing was down in the Astico valley and close upon Arsiero, and on the following day his centre crossed the Posina in force and attacked the Italian 27th Div. on the southern slopes of the valley. Stiff fighting took place beneath Soglio di Campiglia and Pria Forà, and the Italians withdrew to the mountain line which had been hastily prepared from Forni Alti by Monte Spin to Pria Forà. Retiring on the night of May 29, the troops that were to fall back upon Pria Forà lost their way in the dark and kept too far south, halting on Monte Ciove, the ridge that joins Pria Forà to Monte Novegno and Monte Brazome. At dawn the mistake was realized, but the quick-following enemy were already in possession of Pria Forà, which is almost impregnable from the south. A desperate attack failed to retrieve the error, and Pria Forà remained in possession of the Austrians.

The line now held by the Italians (27th and 9th Divs.) was the last bulwark defending the plains in this sector, and both here and across the Astico the Austrians made a great effort to break through. The bulk of the 30th Div. was slowly pushed back across the Val Canaglia, in spite of a prolonged and gallant resistance by the Grenadier Bde. on Monte Cengio. Although the Grenadiers finally lost the summit of Cengio, they held on to the lower slopes above Schiri, and Dankl was unable to make headway in the valley, while the right of the division was swung back to the western slopes of Monte Pau. For a long fortnight Dankl hammered at the line south of the Posina and east of the Val Canaglia, but could not gain a yard. On June 1 the 27th Div. front was reduced, the remade 35th Div. under Gen. Pettiti di Roreto coming into line in the Novegno sector, and the 9th (Gen. Gonzaga) taking both sides of the Astico valley. Dankl's attack was specially directed against two points: Monte Pasubio, where troops of the VIII. and XV. Corps were thrown again and again to the attack, and the Novegno sector, where the Archduke Charles concentrated his main effort against Pettiti's troops. The attack was bound to follow this direction. It has been suggested that the Archduke should have pushed straight for the plain, down the Lower Astico valley. If ground had been gained here it would have been useless. The weak point of the Austrian position was that their successes were gained on a constantly narrowing front. The wings of the Italian line had held firm, and it was above all necessary to gain room south of Arsiero. On June 2, 3, 4 and 5 massed infantry attacks were delivered south of the Posina, but no impression was made on the Italian lines.

Meanwhile von Koevess had been pushing back the Italians in the Seven Communes. On May 28 Asiago was evacuated, and farther north the 34th Div. retreated from east of the Galmarara across the parallel valleys of Nos and Campomulo. Farther north again the Austrians gained ground on the Marcesina plateau and so came within 4 m. of Primolane in the Val Sugana, a point well behind the Italian lines in the valley. But communications were nearly impossible here, and von Koevess had to make his effort more to the south, narrowing still further the front of attack. An endeavour to gain ground in the Val Sugana had failed on May 26, and no other attempt was made in this sector, for which, in fact, there were no more troops available.

By June 2 Cadorna's V. Army was assembled in the Vicentine plain, and on June 4 Brusiloff broke through at Lutsk. The first news of the Russian attack did not perturb Austrian headquarters, though Gen. von Cramon was taken aback. Conrad thought that his line in the east was firmly held. In a few days the situation was changed altogether. But even before the news of the disaster had reached Bozen it was clear that the offensive against Italy had failed. Von Koevess was to gain a little more ground. After four days' heavy fighting east of the Campomulo valley and towards the head of the Val Frenzela, on the evening of June 8 the Italian right on Monte Castelgombergo was forced to retire from the summit of the mountain, but no ground was lost towards the Val Frenzela. The Austrians were only 3 m. from Valstagna, low down in the Brenta valley, but they had shot their bolt.

In spite of the news from the Russian front the attack was continued, south of Asiago and south of the Posina, for 10 more days. Here were the shortest routes to the plain, and here the Austrians had been able to bring up their guns in sufficient numbers. The Archduke Charles continued his attacks against Pettiti's division, and Kirchbach's I. Corps made a great effort against the Italian positions south-west of Asiago. With the arrival of reinforcements the Italian line was once more rearranged, Gonzaga's 9th Div. passing to the X. Corps command (Gen. Grandi), the second division of the Corps (the 20th) lying in reserve, while the XXIV. Corps (Gen. Secco) came in between the X. and the XIV., its front-line division (the 32nd) taking over the gallant Grenadier Bde., which had suffered very severely in the Cengio and Val Canaglia fighting, and the 33rd being held in second line till June 7, when it replaced the 32nd.

The command of the 30th Div. received two fresh brigades, Forlì and Piemonte, on June 7, after a furious attack which gave the Austrians a footing on Monte Lemerle, and for 10 days the division fought off repeated infantry attacks. On June 15 the Austrian command issued an army order saying that Monte Lemerle would fall in two days, and that only three mountains blocked the way to Milan. For four days the Austrians attacked, making a last effort on June 18, when 20 battalions were sent in against the Lemerle-Magnaboschi line in an attempt to drive a wedge between the Italian 30th and 33rd Divisions. The attack failed completely, thanks to the heroic defence of the Forlì Bde., and the admirable work of the Italian field guns. To the east of the Val Canaglia the result was the same, the Liguria Bde. of the 33rd Div. holding their ground against repeated infantry attacks, backed by greatly superior artillery fire. Weakness in artillery was Cadorna's main preoccupation for many days. In the early stages of the offensive the I. Army had lost over 400 guns, including over 120 heavy and medium calibre. The first reinforcements had to be sent to strengthen the left wing. The next urgent need was north of Asiago, where the 34th Div. was reinforced by guns sent up by Aego, and in the Lower Astico, to stop the Archduke Charles. The troops between Asiago and the Val Canaglia had very few guns, and even when sufficient artillery reinforcements were available Cadorna preferred first to strengthen his wings for the counter-attack that he was already preparing.

The Archduke Charles made his last infantry attack on June 14, at the close of three days' heavy fighting for Monte Ciove, in which the Cagliari Bde. withstood repeated attempts to break through at this vital point. The rest of the division was equally staunch, and the troops were helped by the example of their commander. Pettiti had established his divisional command far forward on Monte Novogno, where it came under the heaviest shell-fire. All around the ground was pocked with shell-holes; several times telephonic communication was interrupted, so that orders had to be given by megaphone or bugle; on June 22 the majority of the divisional staff was put out of action by a direct hit. The command was obviously too far forward, but it was the knowledge of their general's presence, amid the same dangers as themselves, that kept the men firm in their places in spite of the long strain and terrible losses. The Cagliari Bde. lost two-thirds of its strength, and other units suffered nearly as heavily.

The last Austrian blow was struck on June 18, south of Monte Lemerle, in vain, when already the first move of the Italian counter-attack had taken place. Cadorna had declined to draw upon his new V. Army prematurely, as he wished to keep a "mass of manoeuvre" in hand against the possibility of a break-through by the Austrians; but by June 2 he felt himself master of the situation. He had 12 divisions in the plain under Frugoni, and the attack was already slackening. The XXIV. Corps was detached from the V. Army and sent to the south of the Asiago plateau, as already described, and orders were given to the XX. Corps to concentrate north of the Val Frenzela and prepare to attack the Austrian left. The attack was not to be made until the position in the centre was assured, and it was to be accompanied by an advance from Pasubio upon Col Santo. On June 13 Cadorna took counsel with his generals, who were nearly unanimous in expressing a grave view of the situation. Bertotti was confident that he had the measure of his adversary in the Pasubio sector; the others felt themselves still hard pressed by the Archduke Charles and von Koevss's right wing. Cadorna had confidence in his own estimate of the situation, and confirmed the order for an attack by the XX. Corps, which came into action between the XIV. and the XVII. The Alpine troops on the right of the Corps pushed forward quickly and occupied various important heights on the northern rim of the Asiago plateau. But the Austrians were now getting ready to go out of the salient and back to a strong line which they had already selected.

Attacking on May 25, all along the line, the Italians found the invaders in retreat. In some places rear-guards were left to

cover the withdrawal; in others the Italians, advancing cautiously, in some cases too cautiously, found no resistance until they had made considerable progress over the difficult ground. The counter-offensive, which was to be directed against the two sides of the Austrian salient, was never fully developed, for it was anticipated by the Austrians, who withdrew skillfully and in good order. The line chosen by Krauss ran from south of Rovereto in front of Col Santo to the Borcola Pass; thence along the rim of the Arsieto plateau, north of the Posina and east of the Upper Astico; thence north-eastward across the Val d'Assa to Monte Mosciagh, and thence northward to the old frontier. This gave a very strong defensive line, with ample depth east of the Upper Val d'Assa, which therefore remained entirely in Austrian hands, a useful line of communication in any case, and an invaluable opening in the event of further offensive action.

Cadorna was especially anxious to reach the Portule line, and he reinforced the troops in the Seven Communes (now under the command of Gen. Mambrotti, who had replaced Lequio) by four divisions of the V. Army, now available as a reserve on the understanding that they were not to be employed unless the situation should develop favourably. But the Austrians had a great advantage in position, and used it well. The Italian attacks, handicapped by the limitation imposed, made little headway, though they prevented the dispatch of Austrian units already under orders for the eastern front. Farther south, repeated attempts were made to retake Monte Cimone, which the Archduke Charles had wished to abandon, but which Krauss insisted should be held. Although Alpine troops gained a footing north of the summit they were subsequently blown off by a mine, and Monte Cimone, which rises sheer-sided, like a vast battleship, between the Astico and the Rio Freddo, completely dominating the Arsiere basin, remained in Austrian hands.

Cadorna relinquished the idea of a big counter-offensive as soon as he found a resistance which could only be overcome by long preparation and the use of artillery in mass. The fighting which took place after the first week in July was all directed to masking his intention to attack with all speed upon the Isonzo.

The Austrian attempt to break through ended in definite failure, and even its secondary object, that of preventing the Italian offensive on the Isonzo, was not attained. But the attack was well planned, and conducted with skill and determination. The Austrian artillery fire was very destructive; the transport was admirably organized, and worked very well in spite of the great difficulties of the terrain; the infantry, most of them picked troops, fought with high courage and determination. Failure was due to the fact that the attack met with a resistance that went beyond Conrad's calculations. In the first days of the attack some Italian units, badly placed and badly handled, showed only a feeble opposition. In the weeks that followed, the men who held at Passo di Buole and on Pasubio, south of the Posina and east of the Val Canaglia and in the Seven Communes, outnumbered at first and always outgunned, completely broke up the attack that had begun so well. The casualty list shows the nature of the fighting. The Austrian losses were estimated at over 100,000 men; the Italian figures, up to the end of the counter-movement, are: 35,000 killed and 75,000 wounded, with 45,000 prisoners, many of whom should be counted among the wounded.

The success of the Italian resistance was primarily due to the power of the Italian soldier, when properly handled, to take hard punishment. It has already been said that in the initial phase of the battle the Italian leadership was at fault, and on this point much controversy has taken place, one party blaming Cadorna and another Brusati. In view of the facts and figures it seems impossible to avoid the conclusion that the chief responsibility lay with Brusati. On his own showing he had forces that he considered sufficient, and perhaps they might have been if they had been more skillfully disposed. Brusati had failed to realize the necessity of defence in depth, or the essentials of a good defensive line, but a graver error still was

his neglect in regard to the preparation of second-line positions. It was serious enough that the positions indicated by Cadorna in the early days of the war had not been prepared. Much more serious was Brusati's report that these lines were in a satisfactory state of efficiency, when in fact they were largely untouched. Cadorna relied upon Brusati's reports, and when, at the end of April, he inspected the positions himself, the enemy attack was daily expected, and it was too late to effect more than slight modifications. In reply to the common criticism that Cadorna ought to have inspected the lines earlier, the answer is that he was fully occupied from Oct. to Dec. 1915 with his Isonzo offensive, and that from Dec. to April the greater part of the line between the Val Lagarina and the Val Sugana was under deep snow. After the initial disasters, which can scarcely be laid at his door, Cadorna showed the qualities of a great leader. He was quick to grasp the situation, and effective in the measures he took to cope with it. And he realized, when the outlook seemed blackest and all his generals were against him, that the impetus of the enemy attack was failing and that he could control the situation.

It has been suggested that Cadorna should have pursued his counter-offensive and left the Isonzo alone. There will always be adherents of the fallacy that Italy should have attacked through the Trentino, though they are in the main confined to those who do not know the country, or those who have no experience of modern war. With these, presumably, no argument would serve. To those who maintain that Cadorna should have sacrificed everything in order to improve his defensive position in the Trentino sector, it may be answered that the line on which he stopped (or rather the modification of it necessitated by the retreat after Caporetto), properly prepared, backed by other lines in sufficient depth, and adequately served by new roads, was maintained until the end of the war. In refusing to waste men in attempting more than was necessary Cadorna took the right decision, and won a notable success.

(W. K. McC.)

**ASIA MINOR** (see 2.757).—With the Turkish revolution in 1908 and the Armenian massacres of the following year began a series of radical changes in the political division of Asia Minor; nor was it yet possible in the summer of 1921 to foresee the end. In the Italo-Turkish and Balkan wars of 1911-3 the Ottoman Empire lost islands on the coast of Asia Minor. The World War of 1914-21 saw the end of the empire itself, and the substitution of a Turkish state confined almost wholly to Asia Minor. The occupation of considerable territory by Greece in the region of Smyrna became effective, and at the same time the Turkish Nationalist Government with its capital in Anatolia offered successful armed resistance to the full execution of the Treaty of Sévres. These events were accompanied by further Armenian massacres on the greatest scale. Asia Minor as a geographical entity was therefore in 1921 in no sense any longer a political unit.

**ASKWITH, GEORGE RANKEN ASKWITH, 1ST BARON** (1861- ), English lawyer and civil servant, was born at Morley, Yorks, Feb. 17 1861, and was educated at Marlborough and Brasenose College, Oxford. He was called to the bar in 1886 (K.C. 1908), and in 1899 was one of the counsel in the Venezuela arbitration case. In 1907 he entered the railways section of the Board of Trade as assistant secretary, and in 1909 was appointed comptroller-general of the Commercial, Labour and Statistical Departments of the Board of Trade. He acted as arbitrator in many industrial disputes, and in 1911 was created K.C.B. in recognition of his valuable work in that capacity. In 1911 he became chairman of the recently constituted Industrial Council, in 1912 he made a special report for the Government on the Canadian labour laws, and in 1915 was appointed chairman of the Government Arbitration Committee under the Munitions of War Acts, holding this post till 1917. On the Committee of Production he did important work for the Government. In 1919 he retired from his position as chief industrial commissioner, and was raised to the peerage. His wife, whom he married in 1908, was a daughter of Archibald Peel, nephew of the statesman Sir Robert Peel, and the widow of Maj. Henry

Graham (d. 1902). During the World War she was an active and energetic member of the Central Committee on Women's Employment, and was created C.B.E. in 1918.

**ASQUITH, HERBERT HENRY** (1852- ), English statesman (see 2.769), had been confirmed in power as Prime Minister by the general election of Jan. 1910, but the political situation resulting from it was still one of unexampled difficulty (see ENGLISH HISTORY). On several occasions during the ensuing parliamentary session, he put off importunate questioners, with regard to the policy of the Ministry, by saying that they had better "wait and see." The phrase was remembered, and was often used by critics in subsequent years, especially during the World War, as a compendious description of what they considered to be the procrastinating attitude of the Prime Minister and his Government. But there was no procrastination in Mr. Asquith's attitude in the autumn, as soon as the conference arranged between the opposing political leaders on the constitutional crisis had definitely failed. He and his Cabinet at once took decisive measures to get it settled in their own sense. On Nov. 15—the day Parliament reassembled for its autumn session—they advised the Crown to dissolve, but only on the understanding that "in the event of the policy of the Government being approved by an adequate majority in the new House of Commons His Majesty will be ready to exercise his constitutional powers, which may involve the prerogative of creating peers, if needed, to secure that effect shall be given to the decision of the country." The King reluctantly consented, and the dissolution was announced on Nov. 18; but the terms of the understanding which had been arrived at between the Crown and its advisers were not revealed till the crisis in the following summer. The second general election of 1910 was held in Dec.; and the verdict of the preceding Jan. was almost precisely confirmed.

Having, with the aid of Labour and the Nationalists, who were both thoroughly with him on the constitutional issue, a clear majority of about 120, the Prime Minister went straight ahead with the Parliament bill, which had two main objects: to take from the Lords all power of either rejecting or amending a Money bill, and to provide that a bill passed in three successive sessions by the Commons should become law without the Lords' assent. He carried the second reading in March with the closure, defeated the stubborn resistance of the Unionists in committee by aid of the "kangaroo" closure, and obtained the third reading on May 15 by an unbroken majority of 121. He did not conceal in the debate that the first use to which the new powers conferred by the bill on the Commons would be put was to pass the Irish Home Rule bill, followed by the rest of the controversial Liberal programme. When the Lords, after allowing the second reading to pass, introduced by an enormous majority an amendment (amongst others) providing for the submission to a popular vote of certain fundamental measures, he forthwith announced, in a letter to Mr. Balfour on the day (July 20) on which the amended bill was read a third time in the Lords, that the Government would ask the House of Commons to disagree with the amendments, adding:—

In the circumstances, should the necessity arise, the Government will advise the King to exercise his prerogative to secure the passing into law of the bill in substantially the same form in which it left the House of Commons, and His Majesty has been pleased to signify that he will consider it his duty to accept and act on that advice.

This, the first public announcement of the King's consent to the creation of sufficient peers to pass the bill, produced an explosion among the Opposition; and the Unionist hotheads, among whom Lord Hugh Cecil and Mr. F. E. Smith (afterwards Lord Birkenhead) were conspicuous, shouted "Traitor" at Mr. Asquith in the House of Commons, and refused to let him deliver the speech in which he was to explain his policy. But he had effected his object of dividing the Unionist party; and eventually a sufficient number of peers followed their leaders in bowing to *force majeure* and allowing the bill to pass rather than risk the degradation of their House by an unlimited creation (see ENGLISH HISTORY). Mr. Asquith welcomed the vote of censure which the Opposition promoted in the House of Commons; gave

an account of the understanding entered into with the King before the last dissolution; pointed out that the Parliament bill had been twice approved by the electorate in principle and once in its substantial details, that there was no alternative Government possible and no responsible minister at its head would advise another general election with any hope of a different result. The vote of censure was repelled by the usual Government majority; and, though Mr. Asquith's course had profoundly exasperated his opponents, the direct and unflinching manner in which he had carried his policy through raised his own parliamentary reputation and strengthened his Government.

Having cleared the way by the Parliament Act, which he described as "a landmark in political development," the Prime Minister pressed forward, by frequent use of the closure, in the three following sessions—of 1912, 1913, and 1914—the two bills on which Liberal partisans had specially set their heart, the Irish Home Rule bill, and the Welsh Disestablishment bill. Of the Home Rule bill he took the main charge himself, advocating it as being strictly in accordance with the spirit and tendency of imperial development. In July 1912 he went across to Dublin, and at a great Nationalist meeting in the Theatre Royal he described the intention of the Government to be to unite the English and Irish democracies. While speaking as a ruler respectfully of Ulster, and offering to strengthen the safeguards for her welfare contained in the bill, he resolutely refused, till the autumn of 1913, to consider the possibility of her exclusion even for a time. But after the signing of the Ulster covenant, the enrolment and drilling of thousands of volunteers, and the establishment by Sir Edward Carson of a "provisional Government"—with none of which operations did he think it wise to interfere—he realized that, unless Ulster were placated, the new Home Rule constitution could not be set up without something like civil war. Accordingly, at Ladybank, in Oct. 1913, he said that he desired a settlement by consent, and invited a frank interchange of views; but he stipulated that there must be a subordinate Irish Parliament and an executive responsible to it in Dublin, and that no insuperable bar must be erected to Irish unity. In pursuance of this policy, he announced early in the following March, when moving for the third time the second reading of the Home Rule bill, that the Government would propose that any county in Ulster might vote itself out of the bill for a period of six years. This did not at all satisfy the Unionists, who demanded that Ulster should be omitted till Parliament otherwise ordered. At this moment occurred the incident at the Curragh, where military officers, when questioned on their views, offered their resignations rather than undertake military operations against Ulster. The War Office prevailed on them to withdraw their resignations by an assurance that there was no intention of crushing political opposition to Home Rule; a kind of bargain which the Liberal party and the Liberal press vehemently condemned and the Government itself repudiated. General Seely, the War Minister, immediately resigned, and Mr. Asquith met this situation by himself assuming the seals of the Secretary of State. He laid it down that it was not right to ask an officer what he would do in a remote and hypothetical contingency, still less could it be right for an officer to ask a Government to give him any assurance. Such a claim, once admitted, would put the Government and Parliament at the mercy of the military. He would administer the War Office, he told his constituents, in the spirit of Chatham, who said, "The army will hear nothing of politics from me, and in return I expect to hear nothing of politics from the army." These events raised passions on both sides, but the Prime Minister refused to be moved from his offer. The amending bill was introduced in the Lords, but was transformed by Unionist amendments into one for the permanent exclusion of Ulster—a change which the Government refused to accept. Mr. Asquith then, in a final effort for settlement by consent, risked his popularity with Radicals and Labour men by advising the King to invite the leaders of the English and Irish parties to a small conference at Buckingham Palace. When this conference, too, after a four days' session, failed on July 24, he was relieved of his

difficulty as to the next step by the outbreak of the World War.

In no other domestic measures of his Government during this period had Mr. Asquith taken so prominent and personal a part as in the Parliament Act and the Home Rule bill. But he was, of course, mainly responsible for the drastic use of the closure, in various forms, without which, indeed, it might have been impossible to get the most contentious of the Government bills through at all. He was active in efforts, first to avert, and then to compose the great coal strike of the early spring of 1912. From the third week in Feb. till the middle of March he was in constant conference with both owners and miners; and when conciliation failed he finally introduced and passed a Coal-mines (minimum wage) bill, which brought about a settlement at Easter. With the transport strike in the summer of 1912 he declined to interfere. His various franchise bills came to naught owing to the difficulties introduced by the claim of a large body of women to the suffrage. Though he was prepared to leave that thorny question to be decided freely by the House, he was himself, unlike the majority of his colleagues, opposed to giving women the vote, and was, accordingly, in the last few years before the war, frequently subjected to rudeness and insult by the militant section of suffragists. While in the domestic legislation which he promoted, especially after he was compelled by his own party's electoral losses in 1910 to rely largely on Nationalist and Labour votes, Mr. Asquith leaned to the Radical side, in foreign and imperial policy and in matters of defence he acted up to the Liberal Imperialist principles of which he had been the standard-bearer while in opposition. He took a keen interest in his duties as chairman of the Committee of Imperial Defence; he strongly supported Lord Haldane in his efforts to make the army more efficient as a striking force; he steadily backed first Mr. McKenna, and afterwards Mr. Churchill, in their extensive programmes, which increased the navy estimates from some £32,000,000 in 1908 to nearly £52,000,000 in 1914; he was the first Prime Minister to preside in a colonial, now become an imperial, conference; and while, owing to his Free-Trade principles, he rejected colonial or imperial preference, he pushed forward organized schemes for imperial defence. The experience of the World War, however, seemed to show that he made a mistake in accepting the Declaration of London. In foreign affairs he gave consistent and strenuous support to Sir Edward Grey, who had continued to develop the national policy previously laid down by Mr. Balfour and Lord Lansdowne. This was fully recognized by the Opposition, who supported him on these questions against the sporadic attacks of Radicals, Nationalists, and Labour men. Whenever Mr. Asquith had to speak to the world as the nation's mouthpiece, in Parliament or at Guildhall, he produced a weighty impression by his clearness and candour in statement, and his dignified and sonorous phraseology.

When the world crisis came in the end of July 1914, he had to translate speech into action, with a hesitating Cabinet, and a still more hesitating party, behind him. He, like Sir Edward Grey, had been lulled into comparative optimism by the speciously reasonable attitude of Germany in the Balkan negotiations; and he was confronted by a strong section in the Cabinet, including Mr. Lloyd George, who at first refused to see cause, in the threat to France, for British armed intervention. On the other hand, he had the tender of support from the Unionists in continuation of their foreign policy since 1905. In the end, the violation of Luxemburg and Belgium by Germany solved all his difficulties, and enabled him to preserve his Cabinet intact save for the perhaps inevitable resignations of Lord Morley and Mr. Burns; but even before this happened it was becoming clear that he and Sir Edward Grey would take their stand by the side of France. His public language was eminently worthy of the occasion. On July 30 he told the House of Commons that the Amending bill must be postponed. The issues of peace and war, he said, were hanging in the balance; it was of vital importance that Great Britain, who had no direct interests at stake, should present a united front, and speak and act with the authority of an undivided nation. He left to the Foreign Secretary the duty of explaining the diplomatic position on Monday Aug. 3; but



he himself moved, on Aug. 5, the day after war had begun, the first vote of credit for £100,000,000, maintaining that "the war has been forced upon us." The fight was, first, to fulfil a solemn international obligation; secondly, to vindicate the principle that small nationalities were not to be crushed, in defiance of international good faith, by the arbitrary will of a strong and overmastering power. No nation, he said, ever entered into a great struggle with a clearer conscience and a stronger conviction that it was fighting for principles vital to the civilized world.

In response to a public demand, peremptorily voiced in the press, he now brought Lord Kitchener, who was on the point of starting back, after a brief visit home, to resume his duties as British agent in Egypt, into the Cabinet as Minister of War, surrendering to him the seals which he had held himself for over four months, and he gave him a wide discretion in conducting the war by land. The conduct of the war remained ultimately with the Cabinet, but its day-to-day direction was practically carried on by Mr. Asquith, Lord Kitchener, and Mr. Churchill, with the assistance of their technical advisers. As Prime Minister, too, Mr. Asquith must be accorded his full share in the important measures taken by the Cabinet at this time, such as the financial moratorium, the prompt despatch of the expeditionary force, the enrolment of Kitchener's army, the glad acceptance of colonial help, the decision to bring over native troops from India, and the Defence of the Realm Act. He, however, strained his relations with the Unionists by determining to pass the Home Rule and Welsh Disestablishment bills under the Parliament Act, only providing that neither should come into effect till after the war, and that special provision should be made for Ulster, which should in no circumstances be coerced. He undertook a series of speeches in the autumn, notable alike for patriotic vigour and for lofty eloquence, in order to educate the nation as regards the objects and necessity of the war, and to stimulate recruiting. At the Guildhall on Sept. 4 he said that this was not merely a material but a spiritual conflict, and recalled how England had in the Napoleonic Wars responded to Pitt's dying appeal to her to save Europe by her example. At Edinburgh, on Sept. 18, he said that the German creed of material force was a purblind philosophy, and that, while the British task might take months or years, the economic, monetary, and military and naval position was encouraging. At Dublin, on Sept. 25, he appealed to Ireland to take her due share in a war which was being fought in the interests of small nations. At Cardiff, on Oct. 2, he revealed the fact that, in 1912, the Cabinet had formally notified the German Government that Great Britain would "neither make nor join in any unprovoked attack on Germany," but that Germany had demanded in response a British pledge of absolute neutrality if she were engaged in war—a pledge which, of course, Britain could not possibly give. He finished up this series of orations by a resolute speech at Guildhall on Lord Mayor's day; when he told the city that it would be a long-drawn-out struggle, but that England would not sheathe the sword until Belgium had recovered all and more than all that she had sacrificed, until France was adequately secured against the menace of aggression, until the rights of the smaller nationalities were placed on an unassailable foundation, until the military dominion of Prussia was fully and finally destroyed. On Nov. 25 he formed a war council, consisting of the Chancellor of the Exchequer, the Foreign Secretary, the Indian Secretary and Lord Haldane, in addition to Lord Kitchener, Mr. Churchill, and himself; but the main responsibility still rested on the last three, and the naval and military experts attended in a somewhat undefined position.

As the fervour of the early months of the war died away, many troublesome questions embarrassed Mr. Asquith and his Government. Besides the anxious problem of the Dardanelles expedition, he had to consider whether the system of compulsory service, hateful to the traditions of the Liberal party, had not become inevitable; how to eradicate spying, and to what extent to intern aliens; how to deal with the problem of the liquor trade and traffic, which seriously interfered with necessary production;

how to prevent the occurrence during war of industrial disputes, which frequently broke out in the first half of 1915. Drink and strikes had a close bearing on the problem which became especially urgent in April, the absolute necessity of an enormous increase in munitions of war. *The Times* revealed the perilous shortage at the front; Mr. Lloyd George dilated upon it in the House; but Mr. Asquith, in a speech at Newcastle-on-Tyne on April 30, which was mainly devoted to emphasizing the importance of material in this war and to encouraging miners, shipbuilders, engineers, iron workers, and dockers to further efforts, raised a storm of criticism by denying that the operations in the field had been crippled because of a want of ammunition.

The uneasiness in the country immediately increased, and there was a pronounced demand for broadening the basis of Government. On May 12 Mr. Asquith repudiated the idea that any such step was in contemplation; but a week later, the quarrel which had developed between Mr. Churchill and Lord Fisher at the Admiralty convinced him that there must be a change, and he invited the Unionists, the Labour party, and the leaders of the two Irish parties to join him in office, by forming a Coalition Ministry. From all whom he invited, but Mr. Redmond, he received acceptances, and he was able to find places in his new Cabinet for them without excluding any important previous colleague of his own, except Lord Haldane, whose German affinities had offended public opinion. He gained the services of many powerful men among the Unionists—Mr. Bonar Law, Lord Lansdowne, Mr. Balfour, Lord Curzon, Mr. Chamberlain, Mr. Long, Mr. F. E. Smith, Lord Robert Cecil, Lord Selborne; of Mr. Henderson and Mr. Brace from the Labour party; and of Sir Edward Carson, the Ulster leader. But he kept the premiership in his own hands, and retained Sir Edward Grey at the Foreign Office, and Lord Kitchener at the War Office. He explained his decision in the House of Commons in these words:—

What I came to think was needed, was such a broadening of the basis of the Government as would take away from it even the semblance of a one-sided or party character, and would demonstrate beyond the possibility of doubt, not only to our own people but to the whole world, that after nearly a year of war, with all its fluctuations and vicissitudes, the British people were more resolute than ever, with one heart and one purpose, to obliterate all distinctions and unite every personal and political as well as every moral and material force in the prosecution of their cause.

He emphasized the facts (1) that in the Coalition no surrender was implied of convictions on either side; (2) that there was no change in national policy, which was "to pursue this war at any cost to a victorious issue." His Coalition Government made a good start. He constituted a new Ministry of Munitions, presided over by Mr. Lloyd George, who had by this time impressed the public as being the most resolute and determined of his colleagues; he and his Cabinet issued a great war loan; they introduced a measure for national registration; they imposed an enormously increased taxation; and there was established in the Cabinet a system of pooling salaries, so that every minister should receive the same amount. In June Mr. Asquith paid a four days' visit to the British front in France; and in July he attended a conference at Calais in which British statesmen and generals met French statesmen and generals in order to co-ordinate Allied action—the first of many conferences of the kind. On the adjournment of Parliament on July 28 he said that the war had become a struggle of endurance.

The formation of the Coalition did not stem the agitation for compulsory service; and in the autumn Mr. Asquith's Government appointed Lord Derby director of recruiting, in the hope that his energy would produce such satisfactory results as to obviate the necessity of resorting to compulsion. But Mr. Asquith stated that, if Lord Derby failed to bring in sufficient single men, he would come to the House without any hesitation and recommend some form of legal obligation. Lord Derby had a considerable but not an adequate success; and Mr. Asquith was driven to introduce compulsion in 1916, at first in a somewhat modified form, but later as universally applicable to males between the ages of 18 and 41. These measures caused the resignation of Sir John Simon, the Home Secretary. This

was the third loss of a colleague which the Prime Minister had suffered since the Coalition. Sir Edward Carson, the Attorney-General, had resigned in the autumn owing to the muddles of ministerial policy in the Balkans, and Mr. Churchill because of his exclusion from the immediate direction of the war. All three became occasionally keen critics of their former colleagues, whose delays in this vital matter of universal service weakened and discredited them in the country.

Mr. Asquith took a further step early in 1916 in the direction of close co-operation between the Allies by attending, along with Sir E. Grey, Mr. Lloyd George, Lord Kitchener and Gen. Sir William Robertson, an Allied conference in Paris, representative not only of England and France, but of Russia, Italy, Japan, Belgium, Serbia, and Portugal. Thence he went on to Rome, where he visited the Pope, and made a speech in the Capitol declaring the solidarity of Italy, France, and England at that critical moment of the world's history; afterwards proceeding to the Italian headquarters, where he was received by King Victor Emmanuel and Gen. Cadorna. Later, in June, he and his Government arranged an economic conference, also in Paris, which provided for measures of economic union between the Allies, for conservation of the national resources of Allied countries, and for economic protection against enemy trade "penetration" and "dumping" after the war. His special attention was claimed at the end of April by rebellion in Ireland, the most serious incident of which was the capture of a great part of Dublin for a week by rebels (see IRELAND). After the suppression of the rising by the troops and the prompt execution of the leaders, he appointed a commission of inquiry, and he himself visited Ireland and returned with a conviction that a united effort must be made to reconstitute Irish government. He appointed Mr. Lloyd George to negotiate and formulate suggestions. In the result he proposed a provisional settlement, for the war and 12 months after, on the basis of bringing the Home Rule Act with certain amendments into immediate operation, with the exclusion of six Ulster counties. To this Sir Edward Carson agreed, but Mr. Redmond objected to the amendments, and nothing was done. The negotiations lost Mr. Asquith the services of Lord Selborne as the rebellion had deprived him of those of Mr. Birrell, the Chief Secretary for Ireland.

The basis of his ministry was rudely shaken in the summer of 1916 by the loss of Lord Kitchener at sea. Lord Kitchener's place at the War Office was taken by Mr. Lloyd George, whose reputation for "getting things done" had been enormously enhanced by the energy with which he had organized the Ministry of Munitions. The attack on the Somme seemed to promise an end to the trench war, but after many weeks of most determined fighting the German line was not broken through; and in the latter part of the year Rumania was crushed. These events increased public dissatisfaction, which had been stimulated by half-hearted dealings with the blockade of Germany, with the food problem, and with the creation of an adequate aerial force; and public criticism was focused on Mr. Asquith, whose incautious phrase of six years before—"wait and see"—was frequently flung in his face. In the House of Commons two strong committees, one of Liberals and one of Conservatives, had been formed for the purpose of the resolute prosecution of the war and the keeping of ministers up to the mark. Mr. Asquith's speeches were always resolute enough; he promptly denounced any overtures of pacifists for a premature peace; but he was thought to be lacking in initiative, and to carry into the counsels of war somewhat the attitude of an impartial Cabinet chairman weighing pros and cons and counting heads for a decision.

The War Council initiated under his Liberal Government was continued with very little modification, save in personnel, under the Coalition; and the final authority remained with the Cabinet. It was felt that a small body, sitting daily, with power to act at once without reference, was essential for the proper conduct of the war. Mr. Lloyd George, the most active member of the War Council, by a letter on Dec. 1, demanded the establishment of such a body, with himself as one of its members, but without Mr. Asquith. He subsequently amended his proposal,

giving Mr. Asquith a consultative membership and a power of veto. But it was clear that the effect must be to transfer the main conduct of the war from Mr. Asquith to Mr. Lloyd George. Mr. Asquith, who had consented to reconstruct his Government, refused Mr. Lloyd George's ultimatum; and on Dec. 5 Mr. Lloyd George resigned. Without him Mr. Asquith clearly could not carry on, and he himself resigned the same evening, being succeeded, after some complications, by Mr. Lloyd George. So ended a premiership which had lasted nearly nine years, and left an ineffaceable mark on English history. He carried into retirement his principal Liberal colleagues, including Lord Grey of Faldoon; and many tributes of regard and respect were paid him by the Unionists who had been his colleagues.

After his resignation Mr. Asquith took his seat on the front Opposition bench; but he disclaimed being in any sense a leader of Opposition, and affirmed that his one desire was to give the Government the benefit of whatever experience he had gained. He maintained this attitude throughout 1917, making resolute and helpful speeches in different parts of the country on behalf of the national war aims. In Parliament he rendered material assistance to the Ministerial Franchise bill; and he announced that the services of women during the war had converted him to female suffrage. In 1918 he became rather more critical, and in particular called parliamentary attention to a letter in which Gen. Sir Frederick Maurice, formerly Director of Military Operations, challenged the veracity of ministerial statements. He moved to refer the general's charges to a select committee of the House, but was beaten on a division by 293 votes to 106. This action, taken during the period of the alarming German advance, marked a definite cleavage with the Government, which was widened after the Armistice by the conditions under which the general election was held in December. Mr. Asquith and those of his colleagues who had not joined Mr. Lloyd George, together with a considerable section of Liberal members, declined to pledge their support to the Coalition Government; and desired to be returned as independent Liberals. As the electorate was resolved that those who had won the war should make the peace and begin the reconstruction of the country, he and the whole of his principal colleagues lost their seats, and only 28 of his followers in all were returned. He did not come back to Parliament till Feb. 1920, when he was elected at a by-election for Paisley. This time he appeared as the leader of the independent Liberal Opposition which had been temporarily led in his absence by Sir Donald Maclean; but his followers, though they had gained some seats since the general election, were still smaller in number in Parliament than the representatives of Labour. Possibly for that reason he was more active in the country than in Parliament, devoting himself to efforts for revivifying the Liberal party. He maintained that the time was come to put an end to the Coalition and resume party Government. He attacked ministers for their departures from Free Trade, for their wasteful administration, and for their policy in Ireland. He strongly condemned reprisals in that island, and declared for Dominion Home Rule. For a time he seemed to be recovering his hold on the country; but in the last half of 1920 and in 1921 there was a setback. It was no help to his political position that Mrs. Asquith published in the autumn of 1920 a volume of very frank and indiscreet *Reminiscences*.

In 1918 Mr. Asquith himself published a volume of *Occasional Addresses*, delivered between the years 1893-1916, thus reminding the world that he was a worthy successor of a long line of scholarly and intellectual Prime Ministers, capable of treating with distinction and acceptance matters of the mind wholly unconnected with politics. The book contained, amongst others, Rectorial Addresses to the universities of Glasgow and Aberdeen, a Presidential Address to the Classical Association, and a dissertation on "biography" read before the Edinburgh Philosophical Institution. The universities of the country duly recognized the claims made upon them by his scholarship. Besides being elected to the rectorships, first of Glasgow and then of Aberdeen, he received honorary degrees from Oxford, Cambridge, Edinburgh, Glasgow, St. Andrews, Durham, Bristol and Leeds.

Mr. Asquith had four sons and a daughter by his first marriage, and a son and a daughter by his second marriage. His eldest son, **RAYMOND ASQUITH** (1878-1916), had a brilliant career at Oxford, where he was a scholar of Balliol, gained a first class both in classical moderations and in *lit. hum.*, won the Ireland, Craven, and Derby scholarships, was president of the Union, and was finally elected in 1902 to a fellowship at All Souls. He went to the bar, and acquired a considerable practice, but when the World War broke out he at once sought a commission and was killed in action in France as a lieutenant in the Grenadier Guards. He left a widow and three children. The third son, **ARTHUR MELLAND ASQUITH** (1883- ), distinguished himself greatly in the war, becoming brigadier-general and D.S.O. In 1918 he was appointed controller of the Trench Warfare Department of the Ministry of Munitions, and in 1919 controller, Appointments Department, and member of council at the Ministry of Labour. The fourth son, **CYRIL ASQUITH** (1890- ), followed his brother Raymond in his Oxford career. He was a scholar of Balliol, gained a first class both in classical moderations and in *lit. hum.*, won the Hertford, Ireland, Craven, and Eldon scholarships, and was elected fellow of Magdalen. The war came just at the close of his undergraduate life, and he served in the army before being called to the bar in 1920. Mr. Asquith's daughter by his first wife, **VIOLET**, married his private secretary, Sir Maurice Bonham-Carter; his daughter by his second wife, **ELIZABETH**, married Prince Antoine Bibesco, for 16 years a member of the Rumanian Legation in London, and in 1921 appointed Rumanian minister to the United States. (G. E. B.)

**ASTOR, WILLIAM WALDORF ASTOR, 1ST VISCOUNT** (1848-1919) [see 2.794], died at Brighton Oct. 18 1919. He was in 1916 raised to the peerage, and in 1917 was created a viscount.

His son, **WILLIAM WALDORF ASTOR, 2ND VISCOUNT ASTOR**, born in New York May 19 1879, was educated at Eton and New College, Oxford. In 1911 he successfully contested the Sutton division of Plymouth as a Unionist, but vacated his seat in 1919 on succeeding to his father's peerage. He was chairman of the Government Committee on tuberculosis and of the State Medical Research Committee. During the World War he was inspector of quartermaster-general services, and in 1918 became parliamentary secretary to the Prime Minister. In Jan. 1919 he was appointed parliamentary secretary to the Local Government Board, and retained the same position on the formation of the Ministry of Health in Aug. 1919. His wife, **NANCY WITCHEER ASTOR**, born in Virginia May 19 1879, was the daughter of Chiswell Dabney Langhorne, of an old Virginian family. She married in 1897 Robert Gould Shaw, of Boston, from whom she obtained a divorce in 1903, and in 1906 married William Waldorf Astor, Jr. When her husband succeeded to the viscountcy, Lady Astor, who had taken much interest in the local affairs of her husband's former constituency in Plymouth, was adopted there as Coalition Unionist candidate for the vacant seat in Parliament. She was elected by a substantial majority Nov. 28 1919, thus becoming the first woman to sit in the House of Commons.

**ASTRONOMY** (see 2.800).—This article is intended to cover the principal advances made during 1910-21 in all the departments of astronomy (including astrophysics) with the exception of the more technical results of celestial spectroscopy. Those investigations have been selected for discussion which appear to have had most conspicuous influence on the general current of ideas.

#### I. OBSERVATIONAL ASTRONOMY

**The Sun** (see 26.85).—By means of the spectroheliograph it is possible to obtain photographs of the sun in light of a single wave-length; we thus obtain a picture of the distribution of the matter which emits this wave-length, or a negative of the matter which absorbs it. In practice either calcium or hydrogen light is used, since these elements furnish spectral lines sufficiently isolated to give good results. The emission of a particular line depends on favourable conditions of temperature and density, and these will vary with the level in the sun's atmosphere. Thus the function of the spectroheliograph is not so much to separate the distributions of particular elements as to isolate different levels in the sun's atmosphere, and provide separate photographs of what is occurring at each level.

The recent pictures obtained with this instrument are of great beauty, and reveal remarkable structure, which is entirely lost in the ordinary photographs which confuse all levels in a single

blurred impression. The highest level is given by photographs taken in the red line of hydrogen H $\alpha$ : these show feather-like clouds, whirling vortices, and long narrow black markings which are now known to belong to the red prominences seen projected on the disc. The vortices are of special interest because of their connexion with sunspots; in most cases a sunspot occupies the trough of each whirlpool or whirlwind. If the whirling matter is electrically charged it should act like a solenoid and produce a magnetic field of force; and this consideration led G. E. Hale (1) to test whether a magnetic field could be detected in sunspots. When light is emitted or absorbed in a magnetic field each spectral line is broken up into two or more components—the well-known Zeeman effect; in particular, for light travelling along the lines of force, the spectral line is replaced by two components circularly polarized in opposite directions. Applying the test for circular polarization clear evidence of the magnetic field in solar vortices was obtained. In general the field strength indicated in a sunspot is of the order 2,000 or 3,000 gauss. It is probably owing to the Zeeman effect that a large proportion of the lines observed in sunspots are observed to be slightly broadened.

An attempt to find a law governing the magnetic polarity of sunspots has not been very successful. On the earth, cyclones have a right-handed or left-handed rotation according to the hemisphere, but there is no such regularity on the sun. There is some evidence that the predominant magnetic polarity in each hemisphere became reversed after the sunspot minimum of 1912. It is surprising to find that there is not even a uniform connexion between the polarity of the spot and the direction of rotation of the whirlwind above it. One very general law is, however, recognized. It was pointed out by Carrington that sunspots very frequently occur in pairs, the line joining them being approximately parallel to the sun's equator; now in these pairs the two spots are found to have opposite polarity. Even when the spot group is more complex a similar bipolarity is generally observed; Hale estimates that in 90% of the spot groups the disturbed area exhibits this bipolar structure.

The detailed explanation of these phenomena is difficult. If the magnetic field is due to the whirling of electrically charged gases, strong electric fields should be present; but the attempt to detect electric fields by the Stark effect on the spectral lines has failed. It seems to be a general belief that the origin of the whole disturbance is a vortex filament below the surface, whose two ends come to the sun's surface near the front and rear of the spot group and give rise to the opposite polarities there.

The method of detection of magnetic fields by the Zeeman effect, has been extended by Hale (2) to a determination of the general magnetic field of the sun (i.e. apart from the exceptionally disturbed regions indicated by sunspots) analogous to the terrestrial magnetic field. It is found that the magnetic axis of the sun deviates from the rotation axis, though not so widely as happens on the earth; the inclination of the two axes is 6°. The synodic period of rotation of the magnetic axis is 31.44 days. If we could assume that the source of the sun's magnetic field is a permanent magnetization of its interior, this would give the real rotation period of the sun—a quantity hitherto unknown. Hitherto our study of the sun's rotation has been based entirely on the surface markings, and these revolve at different rates according to their latitude; the period 31.5 days corresponds to that of surface markings in latitude 55°. It may, however, be doubted whether the source of the sun's permanent field lies very deep below the surface; it is found that it diminishes very rapidly as we ascend in level, decreasing from 50 to 10 gauss in about 400 km. The field appears to differ in other respects from that due to a uniformly magnetized sphere, being relatively too strong near the equator, but this is not quite certain.

The value of the constant of solar radiation which is now generally accepted is that determined by C. G. Abbot, viz. that outside the earth's atmosphere the amount of solar energy crossing each sq. cm. of surface is 1.93 gram-calories per minute. This is the same as we should receive if the sun were a black body at a temperature of 5,850° C. (absolute), which may accordingly be taken as the effective temperature of the photosphere. (The definition of effective temperature by different writers is unfortunately not uniform; and some would make the term refer to the quality instead of the quantity of the radiation.) The total radiation of the sun is 3.8, 10<sup>27</sup> ergs per second. The sun's radiant energy differs considerably in composition from black body radiation; and much work has been done on the distribution in wave length of the energy, and the difference in intensity and composition of light received from the centre and the edge of the sun's disc. By comparing observations of the solar radiation made simultaneously at Mount Wilson (California) and Bassour (Algérie) in 1911 and 1912, Abbot (3) believed he had obtained evidence of an irregular variability of the sun ranging over 10% in the course of a few months; since the same variations appeared simultaneously at the two widely separated stations, terrestrial causes

seemed to be excluded. But this supposed variability of the sun is disproved by Guthnick and Prager's (4) photoelectric measurements of the brightness of the planet Saturn. The planet, being illuminated by sunlight, would reflect any changes in intensity of the sun's radiation; the delicate measures possible with photoelectric cells showed that the light is very steady, variations of the amount determined by Abbot being quite excluded.

**Solar System (see 25.357).**—A ninth satellite of Jupiter was discovered by S. B. Nicholson at the Lick Observatory in 1914. Like the eighth satellite it revolves round the planet in the opposite direction to the other seven. The periods of satellites VIII. and IX. are about 739 and 745 days respectively, and the two bodies are revolving in almost equal interlocked orbits in planes inclined at about  $10^\circ$ . Satellites VI. and VII. form a somewhat similar interlocked pair, their periods being 251 and 260 days respectively; but their motions are in the "direct" sense.

Much interest has been taken in the "Trojan Group" of minor planets. These illustrate a special case of the problem of three bodies discussed by Lagrange, viz. that in which the three bodies are situated at the vertices of an equilateral triangle. The Trojan planets have almost the same mean distance and revolution period as Jupiter, and the equilateral condition is roughly fulfilled. The problem of the small librations of such a planet about the triangular point of equilibrium has been discussed by E. W. Brown (5); the condition of stability is that the mass of Jupiter must be less than  $\cdot 0385$  times that of the sun—a condition which is easily satisfied—and the period of the libration is about 140 years. Actually the Trojan planets are at some considerable distance from the triangular points, and the problem of determining the finite librations (as opposed to infinitely small librations) has provided much exercise for mathematicians. Six members of the group are now known, Nos. 588 Achilles, 617 Patroclus, 624 Hector, 659 Nestor, 884 Priam, and 911 (unnamed); of these Patroclus and Priam are near the triangular point  $60^\circ$  behind Jupiter, and the others  $60^\circ$  ahead of Jupiter.

A very curious minor planet was discovered by W. Baade on Oct. 31 1920, temporarily designated 1920 HZ. Its orbit is extremely elliptical (eccentricity 0.65); and its perihelion lies near the orbit of Mars, whilst its aphelion reaches to near the orbit of Saturn. It is generally thought that a body with this eccentricity must necessarily be, or become, a comet, the extreme alternations of heat provoking the disruption characteristic of comets; but HZ shows no signs of a cometary envelope, and is provisionally classed as a planet.

The period of rotation of Uranus round its axis has been determined by V. M. Slipher from measures of the line of sight velocity of the advancing and receding limbs. The result is  $10^h 50^m$  and the direction of rotation agrees with that of revolution of the satellites. Leon Campbell subsequently found that the light of the planet is variable with the same period, presumably owing to unequal brightness of different parts of the surface. The rotation period of Venus still remains a mystery; and there are advocates of the long period of 224 days as well as various estimates of short period (one to three days).

**Latitude Variation (see 16.267).**—The study of the small periodic motion of the earth's axis of rotation (relatively to the earth) which gives rise to "variation of latitude" has been continued at the six international stations (reduced in number during the later stages of the World War). The effect is made up of (a) The free precession of a spheroid rotating about an axis which does not coincide with its axis of figure; the period of this precession determined from the observations is 4324 days; (b) an annual term, which is a forced oscillation due to meteorological and seasonal causes. Owing to interference of these two terms, there is an effect analogous to "beats" in sound waves, the amplitude of the motion alternately rising to a maximum of about  $0\cdot 3$  (30 ft.) and dying out in about six years' period. The annual term appears to be nearly circular (6) and of amplitude  $0\cdot 085$ ; the possible causes contributory to this, such as seasonal circulation of the atmosphere and ocean, snowfall, and vegetation have been investigated by H. Jeffreys (7), who

finds a fair agreement between predicted and observed values. A mysterious Kimura or Z term, which appears in these international results, would, if interpreted literally, indicate an annual approach to the pole and recession by all stations on the same latitude simultaneously—or a shifting of the earth's centre of gravity to and fro along its axis. It is, however, now believed that the term arises from a small systematic error in the observations; independent observations made at Greenwich and Pulkovo (not belonging to the international chain) show either a reduced or zero Kimura term.

**The Stars (see 25.784).**—Progress in our knowledge of the stellar universe must depend largely on the patient accumulation of accurate statistics as to the parallaxes, motions, spectra, magnitudes, etc., of large numbers of stars; it may therefore be well to review the great advance in these data in recent years.

The first photographic determinations of stellar parallaxes reaching a modern standard of accuracy were made by H. N. Russell and A. R. Hinks at Cambridge, and F. Schlesinger at Yerkes, in 1903-7; earlier results are now superseded except for a few of the best heliometer measures made chiefly by Gill. Extensive programmes have since been carried out with large telescopes at the Allegheny, Greenwich, Leander McCormick, Mount Wilson and Sproul observatories, and by 1921 parallaxes of about 1,600 stars had been measured with probable errors generally not greater than  $0\cdot 01$ . The use of a rotating sector to reduce the brightness of the star under observation to that of the comparison stars has made a considerable improvement in the accuracy. Unfortunately it does not follow that we know the distances of 1,600 stars, for many of these parallaxes turn out to be inappreciable. The results emphasize the fact that very few of the stars are sufficiently near for the method to give any close measure of the distance; and a large proportion of the measures are of little use individually though they may throw light on questions of statistical distribution when taken in conjunction with other evidence. We cannot resist the impression that investigation of stellar parallaxes by the trigonometrical method is reaching its limit with present instruments; and perhaps for that reason special interest is attached to a new method of determining the distances of stars described below under "Spectroscopic Parallaxes."

Lewis Boss's *Preliminary General Catalogue of 6,188 Stars* published in 1910 has been an invaluable aid to research with regard to proper motions. It comprises all the brighter stars; and the proper motions constitute a great improvement as regards both accidental and systematic error on anything previously available. Of other catalogues the most notable is the Greenwich 1910 catalogue containing the proper motions of 12,368 stars in the zone Decl.  $+24^\circ$  to  $32^\circ$ ; the accuracy, of course, does not equal that of Boss's catalogue, but it carries our knowledge of the motions of stars in this region as far as the ninth magnitude. We have still very little systematic knowledge of the motions of still fainter stars, which can be measured photographically; attention has chiefly been directed to the detection of exceptionally large motions by the "blink" microscope or by other methods.

The first really extensive lists of radial velocities were published by the Lick Observatory in 1911. At present (1921) about 2,070 have been determined; these have been collected in a catalogue by J. Völké. Progress would have been more rapid but for the large proportion of spectroscopic binaries, which makes it necessary to repeat the measures several times at suitable intervals in order to discriminate between orbital motion and the true secular motion which is looked for. Orbits of 172 spectroscopic binaries are known; and in addition there are about 450 spectroscopic binaries with orbits as yet undetermined. It appears therefore that approximately one-quarter of the stars examined have proved to be spectroscopic binaries. Allowing for systems of wider separation (not detected by varying radial velocity) the actual proportion of binaries must be still higher.

The apparent magnitudes of stars range from  $-1\cdot 5$  for Sirius, to  $20^m$  and upwards for stars obtained by long exposures with the

largest instruments. The corresponding light ratio is more than 100,000,000 to 1; and it is an important and not very easy problem to subdivide this range accurately. For this purpose a set of 96 standard stars has been chosen near the North Pole, called the Harvard Polar Sequence; their magnitudes stretch at short intervals from the first to the twenty-first, and when once these have been accurately fixed on the absolute scale, it is comparatively easy to determine the magnitudes of any other stars by differential comparisons. There is some systematic difference between the standard magnitudes of the sequence adopted at Harvard and Mount Wilson respectively for part of the range, which is still being inquired into; but good progress has been made in establishing an accurate and absolute basis for magnitude determinations. Separate standards are needed for visual and photographic magnitudes; their relation has been fixed by international convention so that visual and photographic magnitudes agree for stars of type A between  $5^m.3$  and  $6^m.5$ . Photographic magnitudes have been determined at numerous observatories, one of the most valuable pioneer investigations being K. Schwarzschild's *Göttingen Aktinometrie* of the brighter stars. Most of our data of visual magnitudes are due to Harvard (where the late E. C. Pickering alone made a million and a half photometric measures) and to Potsdam observatories. It is now becoming usual to determine "photo-visual" as equivalent to visual magnitudes, i.e. to use a photographic plate of colour-sensitivity corresponding to that of the eye.

Since the photographic plate is most sensitive to blue light and the eye to yellow light, the difference, photographic *minus* visual magnitude, gives a quantitative measure of the colour of the star. This is called the "colour-index." As might be expected, it is very approximately a function of the spectral type, so that the spectral type may generally be inferred from the colour-index and *vice versa*. This affords a very useful method of classifying stars too faint to permit of spectroscopic examination. The colour-index ranges from about  $-0^m.5$  for the bluest (type B) stars to  $+1^m.0$  for the reddest stars (type M). The Draper notation has almost displaced Secchi's and other early nomenclatures of spectral type. The principal stages from the hottest to the coolest are denoted by the letters B, A, F, G, K, M; and intermediate stages are estimated in tenths, e.g. "G5" means halfway from G to K<sub>0</sub>. Types B and A correspond to Secchi's type I; F, G, K to type II; and M to type III. Typical stars are B, Rigil; A, Sirius; F, Procyon; G, the Sun; K, Arcturus; M, Antares. In addition, the somewhat rare Wolf-Rayet stars form type O preceding and hotter than type B; and type N (Secchi's type IV) appears to form an alternative branch succeeding K and parallel with M, the bifurcation perhaps depending on whether the star has an oxidizing or reducing atmosphere. More recently a type R, probably intermediate between K and N, has been added. In types M and N the temperature is low enough for the spectra of chemical compounds to appear prominently; type M is characterized especially by titanium oxide, and type N by compounds of carbon. A catalogue of the spectral types of 230,000 stars classified by Miss A. J. Cannon is in course of publication by the Harvard Observatory; about half of it has already appeared.

**Giant and Dwarf Stars.**—It will be realized that this great gain in quantity and quality of the material available for discussion has permitted of considerable advance in our knowledge of the structure of the stellar universe, since 1910. The most far-reaching of the recent discoveries is the detection of the two classes of "giant" and "dwarf" stars.

To understand this distinction we must go back to Homer Lane's theory of the evolution of gaseous masses (see 25,788). Starting with a very diffuse globe of gas held together by its own gravitational attraction, the conditions of equilibrium require that its temperature must rise when it contracts through radiation of heat. This rise of temperature continues so long as the material is rare enough to follow the laws of a gas; but as the density approaches that of a liquid the changed conditions limit the rise, and ultimately the temperature begins to fall again; the fall continues until the star finally becomes extinct. It follows that any particular temperature is passed through twice, once ascending in a comparatively early stage of evolution, and once descending in a later stage. Now the Draper and other standard classifications of stellar spectra are practically temperature classifications of stars; that is to say, temperature is the primary condition which determines the appearance of the lines and bands distinguishing the spectral types. So in any type of spectrum we have two groups of stars which agree in temperature but are wide apart in all other respects; more particularly they differ in diffuseness and stage of evolution. For example, the present effective temperature of the sun is  $6,000^{\circ}\text{C}$ .; it has a density greater than water and is accordingly in the dense descending stage; but at an earlier epoch it must have passed through the same temperature ascending. It was then a diffuse globe of about 10 times its present diameter and 100 times its present surface; the temperature of the surface being the same, it then gave 100 times as much light as now. These two stages are called the *dwarf* and *giant* stages respectively, and the most conspicuous outward characteristic is the great difference of luminosity, due to the larger surface area in the giant stage.

Instead of having a single sequence of evolution B, A, F, G, K, M we see that a star must start as a giant of type M, ascend the series towards type B, and then descend as a dwarf to type M again. It depends on the mass how far up the series it gets, and probably a star must be three or four times as massive as the sun in order to reach the high temperature of type B. Smaller stars will turn at A, F, or even lower. As Russell has put it, a star of small mass is a poor self-heating affair. The division of giants and dwarfs is most conspicuous for the lower temperatures, G, K, M, since the corresponding stages are then furthest apart in the evolutionary sequence for types A and F the two groups begin to merge into one another, and the division is less easy to recognize.

These conclusions were put forward independently and simultaneously by H. N. Russell (9) and E. Hertzsprung. The observational evidence drawn from many sources is now overwhelmingly favourable. For stars of known parallax the absolute luminosity can be calculated directly; and when these are grouped according to spectral type the bifurcation of the luminosities is evident. The luminosities of the giant stars depend very little on the spectral type (since the rising temperature compensates for the decreasing surface area), and their absolute magnitudes cluster very closely about the value  $+1^m.0$ . For the dwarfs the decreasing temperature and decreasing surface cause a rapid fall of brightness through the successive types, and the absolute magnitude fades to about  $+10^m.0$  for type M. By the new spectroscopic method of determining stellar distances, Adams and Joy (9) have been able to give striking evidence of the two groups; of 58 stars of type M examined they found that 48 were giants with magnitudes between  $-1^m.0$  and  $+3^m.4$ , and 10 were dwarfs between  $+9^m.8$  and  $+10^m.7$ ; there was thus a clear gap of six magnitudes separating the groups. According to types K and G the groups draw closer together and begin to commingle, but even in type F the frequency curve shows the two distinct maxima. Further evidence is obtained from the study of eclipsing variable stars (10), since the average densities of these stars may be determined from the period and the light curve. For types B and A the densities are fairly uniform, averaging about one-tenth the density of water; but for lower temperatures they clearly bifurcate, the one branch corresponding to dense stars like the sun and the other to rarefied stars with densities often below that of our atmosphere. W. Crucis, R. Z. Ophiuchi and S. X. Cassiopeiae are examples of stars with densities less than 0.001, yet giving spectra classed as similar to that of the sun (density 1.38).

Finally all doubt as to the existence of these giant stars is set at rest by Pease and Anderson's direct measurement of the angular diameter of Betelgeuse made with a 20-ft. interferometer at Mount Wilson in December 1920. The angular diameter was found to be  $0''.045$ . Unfortunately the parallax is too small to be measured with much certainty; but it may be taken as proved that it is less than  $0''.05$ . This makes the linear diameter of Betelgeuse not less than 140 million km. or 100 times the sun's diameter. This is an example of a type M giant at the very beginning of the evolutionary sequence.

**Spectroscopic Parallaxes.**—Although giant and dwarf stars of the same temperature have, broadly speaking, the same spectrum, a detailed examination of particular lines reveals distinctive differences. It was early shown by E. Hertzsprung that those spectra marked by Miss Maury as having the "c-characteristic" belonged exclusively to giant stars. More precise criteria were found by W. S. Adams and A. Kohlschütter in 1914; and the method has been developed by Adams into a means not only of distinguishing the two classes but of determining quantitatively the absolute luminosities of stars. For example, the "enhanced lines" of strontium 4077 and 4215 are relatively strong in stars of high luminosity and weak in those of low luminosity; whereas the "reverse lines" of strontium 4607 and calcium 4455 behave in the reverse manner. Thus measures of the relative densities of these lines give an indication of the luminosity of the star. In a general way we can understand the reason; enhanced lines come from ionized atoms, so that they appear when the conditions are favourable to ionization. Other conditions being equal, low density increases the ionization so that the enhanced lines are likely to be strengthened in stars of low density, i.e. the giants—as turns out to be the case. Considerable progress in the theory of ionization in stellar atmospheres has been made by M. N. Saha (11), the results being in good agreement with the observed conditions of emission of the corresponding spectral lines. But Adams's spectroscopic method of determining absolute luminosities (and hence parallaxes) is at present entirely empirical; that is to say, the curve connecting absolute magnitude with the differential intensity of the selected lines is first deduced from and tested by stars of known trigonometrical parallax; it is then applied to deduce the luminosities of other stars. Parallaxes determined by this method for 1,650 stars have already been announced (9).

**Red Dwarf Stars.**—Two very feebly luminous stars have been discovered which are of special interest owing to their closeness to us. In 1916 E. E. Barnard detected a star of visual magnitude  $9^m.7$  in

<sup>1</sup> The absolute magnitude is the magnitude at a distance of 10 parsecs. The parsec, or distance corresponding to a parallax of 1", is  $19.2 \times 10^{12}$  miles. The absolute magnitude of the sun is very nearly  $5^m.0$ ; thus the zero of absolute magnitude is a star 100 times as bright as the sun.

R.A. 17<sup>h</sup> 53<sup>m</sup>, Dec. 4<sup>th</sup> 27' N., having an annual proper motion of 10".3, the largest yet known. Its parallax is 0".52, which makes it the second nearest star (α Centauri being the nearest). A faint companion to α Centauri (sharing the same large proper motion) was discovered in the same year by R. T. A. Innes; its visual magnitude is 11<sup>m</sup>.0, and it has been verified that the parallax is practically the same as that of α Centauri. It appears that this companion is distant 70,000 astronomical units from the principal components, and its period of revolution round them must be a million years. It is now on the near side of its orbit so that it is actually the nearest star known; for that reason it has been named Proxima Centauri. Barnard's and Innes's stars, being both faint and close to us, must be of very low intrinsic luminosity; with them may be grouped two other companions to stars of large parallax, forming the four intrinsically faintest stars yet known:—

Barnard star	absolute visual magnitude	13 <sup>m</sup> .3
Proxima Centauri	absolute visual magnitude	15 <sup>m</sup> .4
Groombridge 34, <i>oomes</i>	absolute visual magnitude	13 <sup>m</sup> .4
Fl. 2123, <i>oomes</i>	absolute visual magnitude	12 <sup>m</sup> .3

As extinction is expected all four are red stars in the last stage before extinction, so that photographically their magnitudes are even fainter. Proxima gives less than 1/10,000 of the light of the sun. A distant companion to Capella discovered by Furiühjelm must also be very faint; but it is probably brighter than those above mentioned.

At the other end of the scale it is uncertain what is the maximum luminosity reached by the stars, because of the smallness of the parallaxes of those which are likely to be the brightest. Canopus, Rigel, and some others may approach or even surpass  $-5^m.0$  (10,000 times the sun's luminosity), but it is not possible to obtain satisfactory evidence of anything brighter. The known range of absolute stellar magnitude is thus from  $-5^m.0$  to  $+15^m.0$ , or a hundred-million-fold ratio of luminosity, with the sun just at the middle. This range is much the same as the known range of apparent brightness (in spite of the distance factor affecting the latter); so that apparent brightness is practically no guide to the distance. Stars of low luminosity are far more common in space than those of high luminosity. Thus we find the four red dwarfs above mentioned within a very small distance from the sun, and doubtless they are equally plentiful throughout the stellar system; but we have to extend our net to very great distances to catch Canopus and Rigel representing the most brilliant stars, and they ought to be regarded as very exceptional freaks of nature. Perhaps it is unfortunate that these exceptional stars catch our attention by their brilliancy, and figure to a disproportionate extent in our catalogues.

**Masses of Stars.**—In striking contrast to the enormous range of intrinsic brightness, is the comparative uniformity of the masses of stars. Some knowledge of their masses may be gained from a study of the orbits of visual binaries of known parallax, and also from spectroscopic binaries (in which case the parallax is not needed). In general the range of mass is surprisingly small, the result being usually between one-half and twice the sun's mass. Exceptions probably appear more numerous than they really are, because of our tendency to pick out the very luminous stars, which are believed to have masses above the average. Stars of type B are found to be on the average three or four times as massive as the others, confirming the view already mentioned that only a star of large mass can attain the highest temperatures. Both components of V. Puppis (type B1) have masses not less than  $17 \times$  sun's; these are the greatest yet measured, though we suspect that masses up to, say,  $50 \times$  sun may occasionally occur. The smallest mass known is that of the faint component of the double star Krueger 60 which is between  $1/6$  and  $1/8 \times$  sun. Attention to these extreme cases scarcely does justice to the uniformity of the great majority of the stars; from a theoretical relation between luminosity and mass for giant stars it is probable that 90% will have masses between  $1/2$  and  $2 \times$  sun.

Advantage is taken of this uniformity to determine the so-called "hypothetical parallaxes," or dynamical parallaxes, of double stars. If  $a$  is the semi-axis of the orbit in astronomical units,  $P$  the period in years, and  $m_1 + m_2$  the mass of the system in terms of the sun, we have

$$m_1 + m_2 = a^3 / P^3$$

Thus  $a$  can be found if  $m_1 + m_2$  is known or guessed. We may assume with fair probability that  $m_1 + m_2 = 2$ , the possible deviations being comparatively unimportant because the cube-root is taken in determining  $a$ . But the value of  $a$  in angular measure is found from the apparent orbit in the sky; comparing the angular measure with the linear measure given by the above calculation, we at once find the distance or parallax of the star. It is possible to modify the procedure so that it can be used when only a small arc of the orbit has been observed. Dynamical parallaxes of 556 double stars have been published by J. Jackson and H. H. Furner (12); from these the absolute magnitudes and linear velocities (transverse to the line of sight) were calculated. The magnitudes showed clearly the bifurcation into giants and dwarfs. The linear velocities were combined to give a determination of the sun's motion through the stellar system, the result being a velocity of 19.1 km. per sec. towards the Apex R.A. 273°, Dec. +34°. This agrees remarkably well with the values

generally accepted; and in particular the accordance of the speed with the value 19.5 km. per sec., obtained from the discussion of spectroscopic radial velocities, shows that the assumed mass  $2 \times$  sun must be almost exactly the average mass of a double star system.

**Fixed Calcium Lines.**—In certain spectroscopic binaries, the curious phenomenon of "fixed calcium lines" is observed. Whereas the other lines of the spectrum shift to and fro as the star approaches and recedes in its orbit, the narrow K line of calcium remains stationary. It is clear that there must be, somewhere between us and the star's surface, an absorbing cloud of calcium vapour, which does not follow the star in its orbit. The phenomenon was first pointed out by Hartmann in 1904 for the star δ Orionis; more recently it has been observed in other cases, and more than 20 such stars are now known. All belong to the very hottest spectral class Oe-Bz; but this is not so significant as is often supposed, because at lower temperatures the K line appears in the spectrum of the star itself and would confuse the observation of the fixed calcium cloud. There are two possibilities, (a) that the cloud surrounds the whole binary system, the components revolving within it without appreciably disturbing it, (b) that the cloud has no connexion with the star, but consists of calcium vapour perhaps distributed widely in interstellar space. The hypothesis (a) was apparently contradicted by the fact that measures of the velocity of the fixed cloud did not agree with that of the centre of mass of the binary system; but the differences are not large, and may perhaps be ascribed to errors of observation or other causes of spectral shift. Hypothesis (b) seems the simplest; it suggests that vapours in very minute quantities may be diffused through space or float in extended clouds; the rarity of detection is due to the fact that the corresponding "fixed" spectral lines would in most cases be blended with similar absorption lines occurring in the atmospheres of the stars. Miss Heger at the Lick Observatory has recently discovered that the sodium lines D<sub>1</sub> and D<sub>2</sub> in δ Orionis are also "fixed."

**Cepheid Variables.**—Many new facts have emerged with regard to the class of short-period variable stars typified by δ Cephei. The three leading classes of variable stars are (a) long-period variables, (b) eclipsing variables, (c) Cepheids. In the first-named, the variation is undoubtedly due to a physical process in the star itself, which alternately blazes up and subsides; in the second, we have to do with a double star and the change of brightness is due merely to eclipses of one component by the other; the conditions which cause the variation of the third class—the Cepheids—are much more puzzling. The first question is: is the Cepheid a binary star? The spectroscopic answer is in the affirmative; for it shows a radial velocity increasing and decreasing in the period of the light fluctuation; it has generally been taken for granted that this must represent orbital motion. But the change of light cannot be attributed to eclipses; not only is the light curve of a different character, but minimum brightness always occurs when the star is receding most rapidly—at a time when the other component could not be between it and us. There must be an actual variation in the rate of radiation by the star, and this has been confirmed by H. Shapley (13), who showed that the spectral type (and presumably the surface temperature) changes during the period. For example, δ Cephei changes from type Fo at maximum to G2 at minimum; this periodic heating and cooling is the main cause of the change of brightness. One suggested explanation is that the orbital motion occurs in a resisting medium, so that the front side of the star is brighter than the rear side on account of the impact of the medium; this would explain why minimum brightness always occurs when the star is retreating. But opinion is now tending towards a pulsatory theory proposed by H. Shapley (14) which rejects the binary hypothesis altogether. The fact is that there is literally no room for the supposed second component required by the binary hypothesis. The Cepheids are giant stars filling a large volume, and the "orbit" is always small compared with the dimensions of the star itself. When we calculate the size of the orbit of the supposed companion (which we can do, knowing the period and approximate mass of the system) we find that it would graze or even lie inside the principal star—a *reductio ad absurdum* of the binary hypothesis. Further, a relation has been found between period and density in these stars which points to the period being determined by intrinsic conditions; such a relation is quite unintelligible if the period is provoked by an external cause, viz. the revolution of a companion. Accordingly Shapley suggests that the variable is a single star which dilates and contracts with a regular pulsation; and the observed motion of approach and recession refers, not to the star as a whole, but to the upheaval and subsidence of the part of the surface presented towards us.

The radius of δ Cephei may be taken as about 15,000,000 km.; the semi-amplitude of the oscillation, according to the observed radial velocities, is 1,370,000 km., or about 9% of the radius. For 15 other fully observed Cepheids the semi-amplitude of the pulsation ranges from 4 to 14% of the radius; this seems an amount of compression and expansion suitable to produce the rather large changes of temperature required. Within narrow limits the period is inversely proportional to the square root of the star's mean density, a relation which seems significant in view of the fact that the pulsations of a gravitating sphere follow this law. Moreover the constant of proportionality is of the order of magnitude predicted by theory.

\* That is, 17 times the sun's mass.



we can calculate that a globe of gas having the mass and density of  $\delta$  Cephei will vibrate in a period between 4 and 10 days (varying between these limits according to the adiabatic constant of the material of which it is composed); the observed period is 5.37 days. The most serious objection urged against the pulsation theory of Cepheids is that it requires a broadening of the spectral lines at minimum and maximum, because all parts of the disc would not be moving with the same speed in the line of sight; this has not yet been observed. It is to be hoped that this crucial but rather difficult effect will be thoroughly sought for in the near future. It may be remarked that some variation of light will arise directly from the dilatation and contraction of the surface; but this is not the leading variation since the actual maxima and minima occur when the star is passing through its mean volume. The indirect effect of the compression, changing the rate of flow of radiation, is much more important; and although the detailed mathematical discussion of the problem has not proved tractable, there is a general accordance of theory and observation.

The name "Cepheid" was at first restricted to stars with periods usually between three and eight days; but longer and shorter periods have been found, and it is now recognized that the "cluster variables" with periods less than a day are of the same nature. These occur abundantly in several of the globular clusters. In examining a globular cluster we have the great advantage that all the stars under review are at practically the same distance from us, so that apparent differences of brightness are real differences of brightness, and are not confused by effects of distance. Now it is found that in a globular cluster Cepheids of the same period have all the same brightness; so that a Cepheid of definite period is a standard object, whose absolute brightness will presumably be the same under all circumstances. This remarkable uniformity was first noticed by Miss Leavitt for the variables in the Lesser Magellanic Cloud; the results have since been extended by Shapley who has calculated the curve connecting luminosity with period. It appears that the Cepheids are among the brightest and probably the most massive stars, ranging in absolute magnitude from  $-1.5$  for periods of three days to  $-4.0$  for 18 days, and so on. Most are of spectral type F—G, becoming redder as the period lengthens; those with periods under a day are of type A. The range of the variation in magnitude is generally between  $0.5$  and  $0.9$ , but doubtless many with smaller variations escape notice. The Pole Star is a Cepheid with a light range of only  $0.1$  and a period of 3.97 days.

*Novae.*—Two "new stars" of unusual brilliance have appeared in recent years. Nova Aquilae III. was discovered independently by a great many observers on June 8 1918, when it was already a first-magnitude star. Its earlier history has been supplied from an examination of photographic records of the sky. From 1888 onwards it remained steady at  $10^{m.5}$  and a photograph taken by Max Wolf three days before discovery showed that it was still normal. Incidentally we may note that it cannot have been a red star (types K or M) or it would have appeared in visual catalogues. On June 7 it had reached  $6^m$  according to a Harvard photograph. The next day (when it was discovered) it had brightened to  $0^{m.8}$ ; and on June 9 it was only slightly inferior to Sirius. Then followed the usual slow decline with occasional fluctuations; and it had faded to  $5^{m.5}$  by the end of October. W. F. Denning discovered a Nova in Cygnus on August 20 1920, which reached the second magnitude. Its earlier history is unknown, but it must have been fainter than  $1^m$  in 1908.

Broadly speaking each Nova reproduces the same sequence of phenomena with remarkable faithfulness (15). At the brightest the spectrum is that of a star of type A5. A few days later broad emission lines appear by the side of corresponding absorption lines which are strongly displaced to the violet. The absorption lines become doubled and tripled, as though there were several layers of uprushing gas travelling at different speeds in the line of sight. About a fortnight after maximum bright nebula lines appear; the continuous spectrum weakens and the star's light now comes mainly from emission lines. After some months the spectrum approximates to that of a planetary nebula. The great speed of upward rush of the absorbing gases is very remarkable, velocities of the order 2,000 km. per sec. being observed; there is no reason to doubt that these velocities are genuine, for the star expands and in the later stages shows a visible disc in large telescopes. The observed rate of spreading seems to agree with the speeds indicated by the spectroscopy. Many theories have been suggested to account for the outbreak. A collision of two stars seems unlikely on account of its statistical improbability; and, moreover, the regular sequence of changes could scarcely be started by a haphazard impact. An eruption from within, whether occurring spontaneously at a certain stage of evolution or precipitated by the entry of the star into a nebula, may be more likely; but this theory also presents difficulties. J. H. Moore has recently obtained evidence that the extended nebulous disc, which is ultimately formed, shows differential motions of rotation in different parts. In any case it seems likely from the very rapid

sequence of changes that the main outbreak is only old-deep. Novae always occur within the limits of the Milky Way (or in spiral nebulae); but this may perhaps be due to the greater depth of the stellar universe in this direction. So far as can be judged the Nova before the outbreak is a dwarf star; and at least in the case of Nova Aquilae it cannot have been a very red star. (The long-period variables, whose violent outbreaks are rather suggestive of the explosion of a Nova, are giant red stars.) We may meditate on the fact that the stars subject to these catastrophes are probably in about the same stage of evolution as that through which the sun is now passing.

*Stellar Velocities.*—In 1910 J. C. Kapteyn and W. W. Campbell announced independently that (after allowing for the solar motion) the average speeds of the stars increase continuously as we pass through the spectral series from type B to type M. Kapteyn deduced the result from the proper motions, and Campbell from the spectroscopic radial velocities. At that time the older view, that the progression from B to M was the order of evolution, held the field; and it seemed as though the motion of a star must increase as it grows older. But the giant and dwarf theory shows that it is not a question of stage of evolution.

Take for example Campbell's figures: the average radial speeds are—type B, 6.5; A, 10.9; F, 14.4; G, 15.0; K, 16.8; M, 19.1 km. per second. In this investigation the K and M stars were almost all giants, so that so far as this analysis goes the youngest stars have the highest speeds; but Eddington found that the dwarf K and M stars at the other extreme in the sequence of evolution have still higher speeds. Of the 19 nearest stars, the nine brightest have a mean transverse speed of 29 km. per sec. (corresponding to a mean radial speed of 18.5 km. per sec.) whereas the 10 faintest, with luminosities less than  $\frac{1}{10} \times$  sun, have a mean transverse speed of 68 km. per sec. (=radial speed 43 km. per sec.). W. S. Adams confirmed this by determination of the radial velocities; of 16 stars whose luminosity is less than  $\frac{1}{10} \times$  sun, the mean radial velocity is 36 km. per sec. or more than twice that of the giant stars of the same type. Similar results were found in a more extensive statistical investigation by Eddington and Hartley. Finally Kapteyn and Adams (16) announced a general progressive dependence of velocity on absolute brightness, the faintest stars having the greatest average speed.

We see then that there is a correlation of speed both with spectral type and with luminosity. It seems likely that the primary association is between speed and mass, the dependence on luminosity and spectral type being due to the correlation of these with mass; as already mentioned, only the most massive stars can reach the hottest spectral types. If this view is correct we must regard the quick-moving dwarf stars of types K and M as having particularly low masses—either because the smallest stars run their course of evolution more quickly, or because mass has been lost along with the energy radiated during their past history. The last suggestion may seem extravagant, but it must be pointed out that all energy has mass; so that a radiating star is continually losing mass; the only question is whether the life of the star is long enough for this loss of mass to amount to anything appreciable; and as to the length of life the most widely divergent views are current. With regard to the explanation of this association of speed and mass, J. Halm (17) has advocated the tempting hypothesis that it is an example of the equipartition of energy—brought about by the laws of statistical dynamics exactly as in a gas where molecules of different masses are mixed. But starting with an arbitrary mixture of stellar velocities, it would take about  $10^{10}$  years to approach this equipartition by mutual perturbations of the stars; and most astronomers shrink from attributing such an age to the stellar universe. A simpler suggestion is that the small stars were formed in the outer parts of the stellar system, where star-forming material was more rarefied; and they have acquired greater velocities by the longer fall towards the central region where we now observe them.

*The Star Streams.*—Many researches have confirmed Kapteyn's discovery that the stars (or at least those near enough for investigation) move preferentially in two favoured directions. Since the article STAR (see 25,784) was written, the spectroscopic radial velocities have become available for testing the theory and they confirm it decisively. Relatively to the sun the favoured directions are inclined at about  $120^\circ$  (the apices being at R.A.  $96^\circ$  Dec.  $-8^\circ$ , and R.A.  $290^\circ$ , Dec.  $-54^\circ$ ); but referred to the mean of the stars they are necessarily two opposite directions along a straight line. The extremities of this axis of preferential motion are called the *vertices*. The following appear to be the most accurate determinations of the vertex by the two independent methods (18):—

From proper motions (Boss's catalogue) R.A.  $94^\circ.2$ , Dec.  $-11^\circ.4$ .  
From radial velocities (Lick catalogues) R.A.  $94^\circ.6$ , Dec.  $-12^\circ.5$ .

It is significant that the line of preferential motion lies exactly in the galactic plane. The phenomenon may be due to two great systems of stars passing through one another; or it may represent some dynamical condition of a single system. The latter view has often been favoured, mainly owing to the very elegant mathematical specification of the corresponding velocity distribution given by K. Schwarzschild's ellipsoidal theory (19).

H. H. Turner (20) suggests that if the stars were originally formed as an extended system with little or no initial motion, the system would settle down to a steady state in which the motions were preponderantly radial; so that, assuming that the sun is placed eccentrically, the stars in its neighbourhood would be moving preferentially in the line towards and away from the centre. An analogy is afforded by the comets in the solar system, which, observed from an outer planet, would appear to move preferentially towards and away from the sun. This explanation seems satisfactory on the whole. It may be objected that, according to statistics of distribution of the stars, the dynamical centre of the stellar system appears to be, not in the direction of the vortex, but  $90^\circ$  away; and the view favoured by Strömberg and by Jeans is that the star-streaming is due to predominant transverse (circular) motion rather than radial motion. It is difficult to see how such a state of motion could originate. H. Shapley has, however, shown that the "local system" (considered in studies of stellar distribution) is but a small part of a greater galactic system; we are on the outskirts of the latter, and its centre is in the direction R.A.262°, Dec.  $-30^\circ$ , agreeing reasonably well with the line of preferential motion.

The more detailed study of the systematic motions of the stars leads to great complexity. After the first approximation outlined above, we have to recognize a third drift, pointed out by J. Halm, which seems to be nearly at rest relative to the mean of the other two. The striking feature is that the type B stars appear to belong to this third drift, and a statistical discussion of their motions shows no indication of the preferential motion, which is always conspicuously manifested (though in somewhat different degrees) by the stars of other types. All this complexity is probably a sign that the stellar system is not in any approximate equilibrium, but is progressing towards a steadier configuration.

**Moving Clusters.**—Many years ago R. A. Proctor pointed out a group of stars in the neighbourhood of the Hyades with practically equal proper motions; the researches of L. Boss (21) have thrown new light on the nature of this association. He recognized as belonging to the group 39 stars spread over an area  $15''$  square; the motions appear to converge towards a certain point in the sky—a perspective effect which would naturally occur if the actual motions in three dimensions are parallel; the direction of the convergent point gives the direction of the common motion of the group relative to the sun.

Knowing the spectroscopic radial velocity of one or more members, we can by an easy geometrical construction find the whole linear velocity and also locate each star separately in space. We thus obtain exceptionally full and exact information as to the distances and luminosities of this group of stars. The cluster is roughly spherical with a diameter of 10 parsecs; there must be many non-associated stars—accidental interlopers in so large a region—and perhaps the most significant conclusion is that the casual attractions of these stars have not been able during the lifetime of the cluster to disturb appreciably the parallelism of the motions and so scatter the cluster. Another remarkable "moving cluster" is formed of five stars of the Plogh together with stars widely separated in the sky, including Sirius, a Coronae and  $\beta$  Eridani. Similar associations are especially frequent among stars of the B type of spectrum, one of the most distinct being a chain of stars crossing the constellation Perseus.

**Number and Distribution of Stars.**—Important statistics of the number of stars down to various limits of magnitude have been obtained by Chapman and Melotte and by P. J. van Rhijn. We give some results of the latter investigation which is the more recent (22).

The total number of stars down to photographic magnitude  $16^m.0$  is 33,000,000; by a somewhat risky extrapolation it is estimated that the total number of stars in the system is between three and four thousand millions, and to reach half this number it would be necessary to go as far as magnitude  $25^m.5$ . (Exactly what is meant by the "system" in the foregoing sentence is somewhat difficult to define; there may, of course, be exterior galaxies or extensions which are not reckoned in these counts.) An important point is the well-known flattened distribution of the stars; up to magnitude  $16^m$ , the stars are distributed in the galactic plane 53 times as thickly as at the galactic poles. This is an increase compared with the concentration of the brighter stars; up to magnitude  $5^m$ , the corresponding ratio is 24. We can easily understand this greater concentration of the faint stars, since on the average they carry us to

greater distances, at which the oblate shape of the stellar system has more pronounced effect.

Taking a lower limit of luminosity  $1/200 \times$  sun, it is estimated that there are 30 stars within a sphere of five parsecs radius round the sun; about 20 of these have actually been identified. If this star density persisted, a sphere of 1,500 parsecs radius would contain 800 million stars, besides an unknown but probably rather large number of extinct stars and of stars giving less than  $1/200$ th of the sun's light. This gives some idea of the possible extent of the star cloud to which we belong; there can be little doubt that the density must fall off very considerably at distances not greater than 1,500 parsecs, more especially in the directions of the galactic poles.

The following table based on an investigation by Kapteyn, van Rhijn and Weersma (23) shows the average parallax of stars of different magnitudes:—

Mag.	Mean Parallax.	Mag.	Mean Parallax.
$1^m.0$	$.060''$	$7^m.0$	$.0090''$
$2^m.0$	$.044''$	$8^m.0$	$.0065''$
$3^m.0$	$.032''$	$9^m.0$	$.0047''$
$4^m.0$	$.023''$	$10^m.0$	$.0034''$
$5^m.0$	$.017''$	$11^m.0$	$.0025''$
$6^m.0$	$.012''$	$12^m.0$	$.0018''$

It is an even chance that a particular star has a parallax between 0.23 and 1.13 times the average parallax for its magnitude.

**Globular Clusters.**—About 70 globular clusters are known, distinguishable from the loose irregular star clusters by their symmetrical and condensed appearance. These have been the subject of a remarkable series of researches by H. Shapley (24).

It has already been mentioned that some of them contain many Cepheid variables, whose absolute luminosities are known from their periods. Thus in Messier 3 (Canes Venatici) the mean magnitude of 110 Cepheid variables is  $13^m.50$ , the individual stars deviating as a rule no more than  $0^m.1$  from this mean. In the cluster  $\alpha$  Centauri 76 variables concentrate with similar closeness about a mean magnitude  $13^m.57$ . It is clear that the difference  $1^m.93$  must correspond to the greater distance of Messier 31 and we easily deduce that the ratio of the distances is 2.43, this ratio being very accurately determined. We are not quite so certain of the absolute distances of the two clusters; but the evidence seems to indicate that the absolute magnitude of these variables (with periods less than a day) is  $-0^m.2$ , which gives the following distances— $\alpha$  Centauri, 5,800 parsecs; Messier 3, 14,000 parsecs. When it is recalled that the usual trigonometrical method can scarcely be applied to determining distances greater than 20 parsecs, the extraordinary power of this method of plumbing space will be realized. The method was first used by E. Hertzsprung to determine the distance of the Lesser Magellanic Cloud.

By this method, and by supplementary devices, Shapley has been able to plot the distribution of the globular clusters in space and to form an idea of the extent of the system which they outline. Even in this vaster system the galactic plane is still a plane of symmetry and of flattening though the clusters extend to great distances above and below, the average distance from the plane being eight kiloparsecs. In plan the system is elongated with its axis in galactic longitude  $325^\circ$ —nearly the direction of star streaming; the greatest diameter is at least 60 kiloparsecs, and the sun is near one end of it so that practically all the globular clusters are found in one hemisphere of the sky. The most remote cluster known is distant 67 kiloparsecs or 200,000 light years. We have to recognize that the "stellar system," dealt with in the researches described previously, is but a small star cloud in this greater galactic system. Roughly speaking those researches may be considered to relate to a domain of about 800 parsecs radius; the sun seems to be fairly centrally placed in the local star cloud (about 90 parsecs from the centre, according to Charlier), but this is on the outskirts of a greater system whose centre is 20,000 parsecs away.

In the foregoing deductions Shapley neglects any possible loss of apparent brightness owing to absorption of light in space. Anything of the nature of a fog or scattering medium would cause greater loss of light in the blue than in the red, and would consequently betray itself by a general reddening of the light of the more distant stars. Such a reddening has been sought for by King, Kapteyn, H. S. Jones, and others, and provisional estimates of the extinction have been made. Shapley considers that the extinction must be altogether negligible, resting his case on the observation that the colour-indices of stars in clusters range from  $-0^m.5$  to  $+1^m.0$  just as those of the nearer stars do. It seems therefore impossible that their light can have been reddened by a scattering medium. The general absorption in space must be so low that a ray of light proceeding through interstellar space can travel for 3,000 years without meeting obstacles sufficient to deflect 1% of its intensity. Nevertheless there are large tracts of obscuring material in particular regions, which hide more or less completely the stars behind. These are found especially in the Milky Way, and consist of dark or faintly-luminous nebulae often of great extent; perhaps there is no hard and fast division between them and the

irregular gaseous nebulae like the Orion nebula. A large obscuring tract in Taurus is estimated by A. Pannekoek to be at 140 parsecs distance; this may be compared with Kapteyn's value 190 parsecs for the Orion nebula. A catalogue of 182 dark markings in the sky has been given by E. E. Barnard (25).

**Nebulae.**—Whereas the irregular gaseous nebulae are comparatively near, and within the local star cloud, the spiral nebulae are now considered to be exceedingly remote—perhaps more remote than the globular clusters. According to one view, they are "island universes" coequal with the great galactic system. Others would consider them rather as outlying dependencies. Unfortunately we have no trustworthy knowledge of their distances; estimates have been made from the apparent magnitudes of the novae which have appeared in them, but these seem to be very speculative. The spirals have been found to possess extraordinarily great velocities in the line of sight and in general the motion is directed away from the sun. This seems to argue a lack of dynamical association with the galactic system. The mean speed of 15 spirals measured by Slipher, is about 400 km. per sec. Independent determinations by Slipher, Wright, and Pease agree well on a velocity of 300 km. per sec. for the Andromeda nebula; for some nebulae speeds exceeding 1,000 km. per sec. have been found. The Theory of Relativity suggests an interesting explanation of these high speeds, and more particularly the preponderance of receding velocities. De Sitter's form of the theory of curved space-time actually predicts an effect of this kind for very remote objects (26).

The planetary nebulae are presumably much less distant. They have a well-marked galactic concentration; but the solar motion referred to them is apparently not the same as that referred to the stars. They do not show preferential motion along any axis. The average radial velocity is 30 km. per sec.—about the same as that of the fastest class of stars (the red dwarfs). When the planetary nebulae are photographed with an objective prism of large dispersion, it is found that the various monochromatic images are of different forms and sizes; so that important information is obtained as to the distribution of the emitting gases through the nebula. Perhaps the most fundamental problem presented by these objects is whether all parts of the disc are independently self-luminous, or whether the light-emission is stimulated by radiation coming from a central star or nucleus.

## II. THEORETICAL ASTRONOMY

**Gravitation.**—The epoch-making theory of gravitation, put forward by Einstein in 1915, is described in the article RELATIVITY. We refer to it here because the new law of gravitation, required by his theory, removes the most outstanding divergence between theory and observation in the solar system—viz. the progression of the perihelion of Mercury. There is still some discrepancy between theory and observation for the motion of the node of Venus; but this is a much smaller residual, and may perhaps even be attributable to accidental errors. Einstein's predicted deflection of light by the sun's gravitational field was verified by the British eclipse expeditions in 1919. His third crucial test—a general displacement of spectral lines to the red in the sun as compared with terrestrial sources—was still in 1921 a subject of controversy.

E. W. Brown's lunar theory, developed according to the methods of G. W. Hill, was completed by the publication in 1920 of full *Tables of the Moon's Motion*. It seems safe to say that no term of appreciable significance has been omitted; nevertheless the moon deviates unmistakably from its theoretical place in an irregular manner. An investigation by H. Glauert (27) seems to show that the irregularities are at least partly due to variations in the rate of our standard timekeeper, viz. the earth's rotation; for the longitudes of the sun, Mercury and Venus exhibit similar irregularities, and the curves closely resemble one another. Besides these irregular changes, there is a general secular acceleration of the moon, which, being cumulative, leads to large changes in the circumstances of ancient eclipses. The historical evidence of all kinds has been rediscussed by J. K. Fotheringham (28) who arrives finally at the values  $10''\cdot5$  for the moon's secular acceleration and  $1''\cdot0$  for the sun's secular

acceleration. The moon goes ahead by the amount  $10''\cdot5T^2$ , where T is the time in centuries. This is the conventional definition of "secular acceleration" in this connexion.

acceleration. These quantities are presumably attributable to tidal friction which causes a direct acceleration of the moon's orbital motion, as well as a spurious acceleration through the increase in the length of the standard of time.

It is now believed that the bodily tides in the earth have little effect and that the most effective retardation is due to tides in land-locked and shallow seas. According to G. I. Taylor the Irish Sea alone contributes  $\frac{1}{4}$  of the total dissipation of energy.

**Evolution of Rotating Masses.**—The figures of equilibrium and the final disruption of rotating fluid masses have been studied in great detail by J. H. Jeans. In agreement with Liapounoff he has found that the so-called "pear-shaped" figure of equilibrium, which succeeds the Jacobi ellipsoidal form, is unstable. For a full account of his conclusions as to the evolution of double stars, spiral nebulae and clusters reference must be made to his book *Problems of Cosmogony and Stellar Dynamics*. With regard to the solar system, he finds himself unable to account for the formation of the planets by rotation alone; and he attributes them to a tidal disruption of the sun having occurred at some distant epoch in the past. If this view is correct the system of the planets is a "freak of nature," owing its existence to a chance encounter of some larger star (which approached within less than the sun's diameter from its surface). Few, if any, other systems of this kind can have been formed; and the common view that the stars in general are attended each by a system of planets may be entirely mistaken.

Mathematical investigations of the possible steady states of a system of stars moving under gravitational forces have been made by Charlier, Jeans and Eddington (29). It appears that the actual conditions are such that each star describes an orbit under the averaged attraction of the whole mass, the casual perturbations of a star by its immediate neighbours being negligible. For a spherical distribution, a steady system can be found in which there is preferential motion in a radial direction, illustrating H. H. Turner's explanation of star-streaming. An oblate system can also be in a steady state with radial star-streaming, provided that it is not alone but forms part of a larger system in which the mass as a whole is distributed spherically. It appears fairly certain, however, that an isolated oblate system moving under its own attraction cannot be in a steady state. For this and other reasons we believe that our own oblate stellar system is by no means in dynamical equilibrium, but is collapsing towards some more permanent form.

As to the stars, H. C. Plummer (30) has found that the distribution of stars in globular clusters conforms to a definite law, which is in fact the adiabatic law of density of a gravitating sphere of gas for which  $\gamma$  has the critical value 1.2. Although this appears to have important dynamical significance, no very satisfactory explanation can be given.

**Radiative Equilibrium of the Stars.**—The discovery that many of the stars—the giant stars—are diffuse globes of very low density, gives a stimulus to investigations of their internal conditions of equilibrium; for the material, being practically a perfect gas, will obey comparatively simple laws. In the earlier researches of Lane and Ritter it was supposed that the equilibrium was adiabatic—that is to say, the material was continually stirred by convection currents, hot gases ascending to replace the continually cooling material at the surface. But it is now clear that the heat passes to the surface not by material transfer but by radiation; and the condition of equilibrium is that each element will settle down to the temperature at which it radiates an amount of heat equal to that which it absorbs from the radiant heat flowing through it. This was first pointed out as probable by R. A. Sampson, and the theory of radiative equilibrium was developed by K. Schwarzschild for the external layers of the sun. Eddington (31) has based on this principle a theory of the equilibrium throughout the interior of a star.

At first the principal unknown constant was the molecular weight of the material of the star. It was, however, pointed out by Newall and Jeans that the atoms were probably strongly ionized at the high temperatures prevailing; and this led to a simple solution of the difficulty. The number of electrons surrounding the nucleus of any atom is approximately half the atomic weight; hence if all the electrons break loose, the average molecular weight will in all cases be approximately 2, since each unattached electron counts as a separate molecule. Ionization is probably not complete and both theory and observation seem to be best satisfied by a value between 3 and 4; but any large uncertainty as to the molecular weight is thus removed. The calculation shows that the rate of radiation of energy of a gaseous (giant) star is given by:—

$$L = \frac{4\pi c}{h} G M (1 - \beta),$$

where M is the mass, G the constant of gravitation, c the velocity of light, h the mass coefficient of absorption of radiation by the material, and  $\beta$  a constant depending on the mass and obtained by solving the quartic equation

$$1 - \beta = 0.0026 M^{1/2} m^{1/2}$$

where M is the mass in terms of the sun, and m the molecular weight in terms of the hydrogen atom. The density does not enter into

the formula for the rate of radiation; and hence (provided  $k$  remains constant) a star will radiate the same amount of energy as it passes through all stages of evolution until it becomes too dense to behave as a perfect gas. This agrees with the observed fact that the average magnitudes of the giant stars are approximately the same for all spectral types. The formula shows also that the total radiation (and, subject to calculable corrections, the absolute luminosity) is a function of the mass, and it becomes possible to calculate the mass from the luminosity—and vice versa. Thus the great majority of the giant stars of types F and G are comprised within absolute magnitudes  $2^{m_0} + 0$  to  $-0^{m_0} .5$ ; these correspond to masses 0.07 to 1.6 times that of the sun—an illustration of the great uniformity of stellar masses. The constant  $k$  must be obtained from our general knowledge of the radiation of giant stars of known mass; it is approximately 20 C.G.S. units, that is to say, radiation after passing a column of stellar material of 1/20 gram per sq. cm. would be reduced to one-third (strictly 1/e) of its original intensity. This is a very high opacity, but it is of the same order as that found in laboratory experiments on X rays, to which the high temperature radiation within the stars is closely akin. It is remarkable that  $k$  appears to vary very little from one star to another in spite of their considerable differences of temperature.

Taking account of the deviations from the laws of a perfect gas, the theory can be extended (though with less certainty) to dwarf stars. The most interesting point is to determine the maximum temperature attained by stars of different mass. Measuring the mass in terms of the sun, a mass  $\beta$  should just attain effective temperature  $3,000^\circ$  (type M), below which it would scarcely appear luminous; a mass  $\beta$  attains  $6,000^\circ$  (type G); mass  $\beta$  attains  $10,000^\circ$  (type A, F); and mass  $2.5$  attains  $14,000^\circ$  (type B). These results will no doubt be revised when better information is available for checking the constants of the theory; but they appear to be reasonably probable.

**Radiation Pressure.**—It is found that the pressure of radiation plays a very important part in the dynamical equilibrium of the giant stars. As already mentioned the stellar material is highly opaque to the radiation; thus the outflowing radiation exerts a large pressure on the absorbing material, tending to support part of its weight. The fraction of the weight carried by the radiation pressure is the quantity  $(1 - \beta)$  in the formula already given. For example (taking molecular weight  $3 \cdot 0$ ) we find:—

$$\text{For star of mass } \frac{1}{5} \times \text{sun radiation pressure supports } 0.044 \text{ of weight}$$

$$\frac{1}{5} \times \frac{0.457}{0.457}$$

This gives a clue to the remarkable phenomenon that the masses of the stars are so nearly uniform. Why should the matter of the universe have aggregated into lumps, whose size is almost always between  $\frac{1}{5}$  and  $5 \times$  sun? We see that this is just the range for which radiation pressure rises from insignificance to importance, and presumably that fact has determined the size of stellar masses. On general grounds it is likely that when radiation pressure counterbalances a considerable part of gravitation, the body would be very liable to disruption; accordingly the chances of survival of stars more than five times as massive as the sun, would be small. The material has thus tended to divide and subdivide until the separate masses fell just below the danger limit, fixed by this criterion of radiation pressure; and afterwards there was no cause for further division.

**Age of the Stars.**—In discussions of the evolution and dynamics of the stars or of systems of stars, the problem arises: What is the time-scale of the process? If astronomers were asked to estimate the length of life of a star from its first luminescence to its final extinction, the answers would probably fall into three groups: (a) The short time-scale, urged by Kelvin, giving a life of about 50 million years; (b) a long time-scale, say  $10^{10}$  years; (c) an ultra-long time-scale of  $10^{18}$  years and upwards urged by those who believe the stellar universe to have approximately reached statistical equilibrium. Belief in the short time-scale rests on Helmholtz's theory that the star's heat comes from the gravitational energy converted as it contracts; in recent years, the cumulative evidence against this "contraction theory" of a star's energy has become very considerable, and it now seems clear that the star must have some much larger store to draw on. The Cepheid variables may perhaps afford us a measure of the rate at which the evolution proceeds. Like other giant stars,  $\delta$  Cephei would need to condense very rapidly if the energy which it radiates came solely from contraction; the increase of density must in fact amount to 1% in 40 years. As already explained the period of the light variation is intrinsic, and should therefore change as the density changes. Calculation shows that the period ought to decrease 40 seconds annually. Now  $\delta$  Cephei has been under careful observation since 1785 and the decrease of period is only just detectable. The value given by E. Hertzsprung is a decrease of 0.08 second per annum. Thus at the present stage evolution is proceeding at a rate no more than  $\frac{1}{5}$  of that required by the contraction hypothesis: and some source of energy is being drawn on to prolong the star's life 500-fold. Assuming that this store of energy is contained in the star (and not picked up continually from space), it seems clear that it must consist of the sub-atomic energy, releasable when the elements are transmuted or possibly when positive and negative electrons annihilate one another. Since all kinds of energy possess mass, an upper limit to the store can be given; the sun's output of heat could be maintained for  $15 \cdot 10^{18}$  years if all the energy contained in it were liberated.

III. INSTRUMENTS

The Hooker telescope, a reflector of 100 in. aperture, installed at Mount Wilson Observatory, is now (1921) the most powerful telescope in the world. It was brought into regular use in 1919. The mirror is a glass disc of thickness 12.8 in. at the edge and 21.6 in. at the centre, weighing over four tons. It is ground to a focal length of 12.88 metres, but can be used with convex mirrors as a Cassegrain with equivalent focal lengths of 48 and 76 metres. The weight on the polar axis is mainly buoyed by cylinders floating in mercury. A 72-in. reflector has been erected at Victoria, B.C. Both these large telescopes are giving excellent performance.

A comparatively small telescope of interesting design was constructed by the late B. Cookson at Cambridge; it is a photographic zenith telescope carried on an annulus which floats in mercury. Rotation about the true vertical is thus secured by flotation instead of by reading spirit levels. After Cookson's death the instrument was removed to Greenwich, where it has been used with great success for determining latitude variation and the constant of aberration. From seven years' observations the value  $20'' \cdot 44 \pm 1'' \cdot 013$  was obtained for the constant of aberration; this is probably the best direct determination of the constant, though scarcely so accurate as the value  $20'' \cdot 47$  obtained indirectly from the solar parallax. A somewhat similar instrument in which rotation about the vertical is obtained by suspension instead of by flotation has been recently installed at Durham Observatory.

An appliance very much used in recent years is a coarse grating consisting of parallel and equidistant metal strips placed in front of the object glass. This grating, with say five "lines" to the inch, seems like a travesty of the diffraction gratings used by physicists; but the action is essentially the same. On either side of the undiffracted image of the star subsidiary images appear, which are in reality spectra of the first, second and higher orders. The distance between the two first order images is proportional to the average wave-length of the light; and hence the grating can be used for determining star colour on a quantitative scale. It also provides a convenient means of obtaining images whose intensities are in a definitely known ratio (calculated from the widths of the strips and spaces), which is of great value in determining an absolute scale of photographic magnitudes. These objective gratings appear to have been first used by K. Schwarzschild acting on a suggestion from A. A. Michelson. Another optical device, suggested by A. A. Michelson so long ago as 1890, has recently been used with great success at Mount Wilson. An interferometer consists essentially of two light-collectors of moderate aperture separated by a base-line of considerable length (as in a range-finder). The beams of light are then brought together, so that for a point source they produce the usual interference fringes. As the base-line extends or contracts the fringes narrow or widen in proportion. For a double star the length and orientation of the base-line can be found in which the bright fringes of one component fall on the dark intervals of the other component, so that the visibility of the fringes is a minimum. In this way the position angle and separation of the components can be measured with great accuracy, and the method is applicable to double stars too close to be resolved in a telescope; in fact the resolving power of the interferometer is greater than that of a telescope of aperture equal to the base-line. At Mount

Wilson excellent observations were obtained by this means of Capella (hitherto known only as a spectroscopic binary), the separation of the components being  $0''.04$ . A still more interesting application was the measurement for the first time of the angular diameter of a star; this has been accomplished for Betelgeuse (which probably has the greatest angular diameter of any star); a base-line of 10 ft. was required for the disappearance of the fringes. The diameter of Arcturus has also been measured, the fringes disappearing when the base-line was 19 feet.

The photo-electric cell has been the means of great advance in stellar photometry. Films of the alkali metals emit electrons in numbers proportional to the intensity of the light falling on them. The light of a star is allowed to enter a cell coated with such a film and the rate of discharge of electrons is measured with an electrometer. In all other methods of photometry the effect observed is nearly proportional to the magnitude, and the photo-electric method is the only one which shows the luminosity directly and not distorted on a logarithmic scale.

A "Stereocomparator" is often used for detecting large proper motions between two plates taken at different epochs. The plates are arranged so as to be viewed one with each eye and combined stereoscopically; stars which have moved appreciably between the two epochs will betray themselves by appearing to stand out in front of or behind the general plane. In the modification called the "Blink-Microscope" the two plates are viewed in rapid alternation; and a motion or change of brightness of a star is detected by a tell-tale flicker.

**BIBLIOGRAPHIES.**—(1) Hale, *Astrophys. Jour.*, 28, p. 315. (2) *ibid.* 38, p. 27; Seares, *Observatory*, 43, p. 310. (3) Abbot, Fowle and Aldrich, *Astrophys. Jour.*, 38, p. 181. (4) Guthnick and Prager, *Veröffentlichungen Berlin-Babelsberg*, Bd. I. (5) E. W. Brown, *Monthly Notices*, 71, p. 438. (6) Dyson, *Monthly Notices*, 78, p. 452. (7) Jeffreys, *Monthly Notices*, 76, p. 499. (8) Russell, *Nature* 93, pp. 227, 252, 281. (9) Adams and Joy, *Astrophys. Jour.*, 46, p. 313, 53, p. 13. (10) Shapley, *Princeton Observatory Publications*, No. 3. (11) Sala, *Proc. Roy. Soc.*, 99A, p. 135. (12) Jackson and Furner, *Monthly Notices*, 81, p. 2. (13) Shapley, *Astrophys. Jour.*, 44, p. 274. (14) *ibid.* 40, p. 448; Eddington, *Monthly Notices*, 79, pp. 12, 177. (15) Straton, *Annals Solar Physics Obs. Cambridge*, p. 14. (16) Kapteyn and Adams, *Proc. Nat. Acad. Washington*, I, p. 14; Eddington, *Observatory*, 38, p. 392. (17) Halm, *Monthly Notices*, 71, p. 634. (18) Eddington, *Monthly Notices*, 71, p. 4; Eddington and Hartley, *Monthly Notices*, 75, p. 521. (19) Schwarzschild, *Göttingen Nachrichten* (1907), p. 614, (1908) p. 191. (20) Turner, *Monthly Notices*, 72, p. 387. (21) Boss, *Astron. Journ.*, No. 604. (22) Van Rhijn, *Groningen Publications*, No. 27. (23) Groningen Publications, No. 29. (24) Shapley, *Astrophys. Jour.*, 48, p. 154. (25) Barnard, *Astrophys. Jour.*, 49, p. 1. (26) De Sitter, *Monthly Notices*, 78, p. 3. (27) Glauert, *Monthly Notices*, 75, p. 489. (28) Fotheringham, *Monthly Notices*, 80, p. 578. (29) Charlier, *Arkiv. för Math. Astr. och Fysik*, 12, No. 21; Jeans, *Monthly Notices*, 76, p. 70; Eddington, *Monthly Notices*, 75, p. 366, 76, p. 37. (30) Plummer, *Monthly Notices*, 71, p. 460, 76, p. 107. (31) Eddington, *Monthly Notices*, 77, pp. 16, 506; *Astrophys. Journ.*, 48, p. 205.

The following recent books on various branches of the subject will be found useful:—C. G. Abbot, *The Sun* (1912); W. W. Campbell, *Stellar Motions* (1913); A. S. Eddington, *Stellar Movements and the Structure of the Universe* (1914); R. G. Aitken, *The Binary Stars* (1918); I. H. Jeans, *Problems of Cosmogony and Stellar Dynamics* (1919). Lick Observatory Publications, vol. xiii., is a mine of information as to the Nebulae. (A. S. E.)

#### ATHLETICS: see SPORTS AND GAMES.

**ATHOS, MOUNT** (see 2.851\*).—In the summer of 1913 the monastic communities of Mount Athos were convulsed by the controversy arising out of the heresy of the Name of God. A Russian monk named Ilarion, in the western Caucasus, had published a book, under the title of *In the Mountains of the Caucasus*, in which he argued that the name of God, being part of God, is divine, and therefore to be worshipped. The book was printed at the Pechersk monastery at Kiev, esteemed the special press of the Holy Synod, and its popularity is shown by the fact that it passed into three editions. Its teaching as to the name of God, which claimed to be based on the authority of such eminent saints as St. Gregory Palamon and St. Dmitri of Rostov, was welcomed with enthusiasm by the monks of the monasteries of St. Andrew and St. Pentelemon, its chief exponent being Antony Bulatovich, an ex-officer of the Hussars of the Guard, who had become a monk at St. Andrew's.

The crisis began when Archbishop Antony of Volinak denounced the doctrine as heretical in *The Russian Monk*. The monks appealed against this to the Holy Synod; but the synod declared against them and ordered the abbots to repress the heresy. The monks thereupon expelled the abbots by force, and their action was approved by the monastery of Vatopedi, the Greek parent house of St. Andrew's. On the appeal of the abbots the dispute was now referred by the Holy Synod to the court of the Patriarch of Constantinople, and the intervention of the Russian Government was invited. The condemnation of the "heretics" by the Patriarch led to their repudiation by the community of Vatopedi, and at the instance of the Russian ambassador at Constantinople the refractory monasteries were subjected to a rigorous blockade.

This failed to subdue the monks, whom the Archbishop of Volinak described as "a band of soft-brained idiots led by a vainglorious hussar." It was feared that the heresy, if suffered to make headway, would spread like wildfire among the ignorant Russian peasantry, and Archbishop Nikon was sent to Athos to threaten the recalcitrant brethren with severe temporal and eternal penalties should they remain obstinate. But his reception was worse than cold, and the Russian Government determined to take strong measures. On June 24, 200 Russian soldiers landed on Mount Athos, and a month later 600 of the monks were deported to Russia, where they were distributed as prisoners in various monasteries. The Holy Synod declared that the peculiar tenets of Bulatovich and his followers were to be known and condemned as "the heresy of the Name of God."

See *The Times*, June 19 and 26 1913.

**AUCTION BRIDGE:** see BRIDGE, AUCTION.

**AUFFENBERG-KOMAROW, MORITZ, FREIHER VON** (1852— ), Austrian general of infantry, was born in Troppau. As a young staff officer he served in the army which occupied Bosnia in 1878. He later commanded the XV. Army Corps at Sarajevo, and in the autumn of 1911 became Minister of War. The ambitious general had many enemies. His active spirit led him to take a vigorous part in the internal politics of the monarchy, his knowledge of the Hungarian and more especially of the Southern Slav question being intimate. He had attracted the attention of the heir to the throne, the Archduke Francis Ferdinand, who had, in spite of much opposition, secured his appointment as Minister of War; but powerful influences forced him to retire after only a year and a quarter's tenure of the office. He won his title in the World War, as the commander of the IV. Army against the Russians, by the brilliant victory of Komarow at the end of Aug. 1914. After the victory Auffenberg succeeded in the difficult operation of completely changing the front of his entire army, with which he moved southwards in time to take part in the second battle of Lemberg; but the superior strength of the enemy made it impossible for him to avert defeat. The general was then called on to resign his command. In April 1915 he was arrested on an accusation of having as War Minister delivered to an unauthorized person a copy of military instructions with a view to speculation on the Exchange, but the court acquitted him.

Auffenberg wrote two books: *Aus Oesterreich-Ungarns Teilnahme am Weltkrieg* and *Aus Oesterreichs Höhe und Niedergang*.

**AUSTIN, ALFRED** (1835-1913), English poet (see 2.938), died June 2 1913 at Swinford Old Manor, near Ashford, Kent. His autobiography appeared in 1911. He was succeeded in the laureateship by Robert Bridges.

**AUSTRALIA** (see 2.941).—Including as it does the adjacent island of Tasmania, but exclusive of its Papuan Territory (about 91,000 sq. m.), the area of the Australian Commonwealth was in 1921 computed at 2,974,581 sq. m., 1,149,320 of which, about five-thirteenths of the total, are within the tropical zone. Between 1901, when the Commonwealth was proclaimed, and 1921, there had been three changes affecting the political boundaries of Australia. In 1906 Papua (the British portion of the island of New Guinea) was taken over from the British Government and constituted a Territory of the Commonwealth. In 1909 the Commonwealth took over an area in the S. of New South Wales which was constituted a Federal Territory and on which was to be built the Federal capital. In 1910 the Northern Territory was taken over from S. Australia and constituted a Federal Territory. The effect of the World War in giving to the Australian Commonwealth, as mandatory under the League of Nations, control of what was German New Guinea and of other ex-German posses-

\* These figures indicate the volume and page number of the previous article.

sions in the Pacific area (roughly about 90,000 sq.m.) does not, strictly speaking, make any change in the area of the Australian Commonwealth since these "mandated" territories are not annexed.

**Papua.**—The suitability of Papua for various forms of tropical agriculture is undoubted, but there is a "labour difficulty" in the way of progress. The Papuan, like most South Sea Islanders, has an aversion to steady work. In Fiji, a British colony in the S. Pacific, a position similar to that existing in Papua has been met by the importing of industrious coolies from India to develop the sugar plantations. The Australian Government, however, is determined to keep Papua for the Papuans. It was proposed in 1908 that the Papuan should be forced to do a certain amount of work, either for himself, for private planters, or for the Government, the argument being advanced that since nature was so bountiful as to keep him in reasonable comfort without work, he would never be driven to labour by necessity, and must, therefore, be brought under some other form of compulsion. The Australian Government vetoed the proposal. In 1918, however, a Native Taxes Ordinance was passed authorizing a tax not exceeding £1 per head on all natives except those in Government employ, or unfit for work, or having four or more living children. The proceeds of the tax will be applied to the benefit of the natives; its effect is designed to stimulate industry on their part. In 1919 about 13,000 natives were engaged in some form of contract labour. The Native Labour Ordinances safeguard strictly the interests of the native workers.

There are about 58,513 ac. under cultivation, mostly planted with coco-nut trees. Rubber, cotton, sisal, and coffee are also grown and mining and pearl-shelling are considerable industries. The system of land tenure is by leasehold; freeholds are not granted; the conditions of leasing are not onerous (see NEW GUINEA).

**The Federal Territory and Federal Capital Site.**—The constitution having provided that the capital of the Commonwealth should be within the state of New South Wales, at least 100 m. from Sydney, the New South Wales Government in 1909 surrendered to the Commonwealth Government some 900 sq.m. of territory around Yass-Canberra, and also an area of 2 sq.m. on the shores of Jervis Bay for the construction of a Federal port; and with these areas went the right to construct a railway from this port to the Federal Territory.

In 1910 the Federal Government took possession of the Territory. It established there in 1911 a military college and later a naval college at Jervis Bay. In 1913 the work of constructing the Federal city was formally begun. A railway connecting the site with the main line was opened in 1914. The World War seriously interfered with further progress and work on the Federal city was still in abeyance in 1921. About £1,000,000 had been spent.

**The Northern Territory.**—With an area of 523,620 sq.m. (more than one-sixth of the continent), having some very fertile land, and with a better river system than most other parts of Australia, the Northern Territory is almost empty and undeveloped. The total pop. (other than aborigines) was 4,706 in 1919. The backwardness of the Territory as compared with the rest of Australia is due chiefly to political causes. When the Australian colonies first set up separate households it was convenient to none of them to include the Territory, and it was left in the hands of the Imperial Government. In 1863 South Australia took over the responsibility for the Territory, intending to connect it with Adelaide by a north-to-south trans-continental railway. With such a railway it would have been brought within the ambit of South Australian development. Without that railway it was actually more remote from communication with South Australia than with any other of the states. The railway was begun. It reached Pine Creek from Port Darwin at the N. end, and Oodnadatta from Adelaide at the S. end; and then hope of its completion was abandoned. When the Commonwealth came into existence it sought a transfer of the Northern Territory from South Australia. But it was not until Jan. 1 1911 that the final stage of the negotiations was reached and the Territory assumed by the Commonwealth. The terms of transfer were that all the past deficits incurred by South Australia in the administration of the Territory should be taken over by the Commonwealth, and that the trans-continental railway should be completed from Port Darwin in the N. to Port Augusta (near Adelaide) in the S. The Commonwealth purchased the existing state railway from Port Augusta to Oodnadatta. It has not yet been found possible to go on with this railway project, but the east-to-west trans-continental railway being completed, the north-to-south in 1921 was being seriously discussed.

In 1912 the Commonwealth Government appointed an administrator for the Northern Territory and took preliminary steps for its development and colonization. As to the possibilities of a white population flourishing in this tropical part of the continent the evidence is reassuring. There is very little malaria, and other specific tropical diseases are absent. The land is generally considered to be suitable for cattle-grazing (there are great herds of wild buffalo), and tropical farming on the coast; for sheep-farming and dairy-farming on the tablelands. There is said to be mineral wealth, but mining results in the past have usually been disappointing. In its policy of development the Australian Government does not propose to allow

any further complete alienation of Crown lands. All titles will be leasehold, but the leases will be in perpetuity, with reappraisal of rent every 14 years in the case of town lands, every 21 years in the case of agricultural and pastoral lands. Up to the present the Northern Territory has not proved a profitable acquisition for the Commonwealth. The year's accounts 1918-9 showed a deficit of £37,760 on an expenditure of £497,301. The administration has been disturbed by troubles similar in character to those which the Mother Country had with the Australian colonists in the early days of Australian settlement.

THE COMMONWEALTH

The Federal Act of July 1900 (see 2,966) united in an indivisible Australian Commonwealth six self-governing colonies, organized as British settlements between 1770 and 1859, which retain their individuality and, for certain purposes, their independence. The federating states, New South Wales (see 19,537 et seq.), Victoria (see 28,37 et seq.), Queensland (see 22,732 et seq.), South Australia (see 25,492 et seq.), Western Australia (see 28,539 et seq.) and Tasmania (see 26,438 et seq.), were left with certain self-governing powers and preserved their own political institutions. Separate notes are added later as to certain details in the internal affairs of the individual states, but in the following account Australia will be considered substantially as a whole, in its aspect of a single national unit.

**Population.**—Public opinion in Australia has at different times condemned as unsatisfactory the rate of growth of the population both by natural increase and by immigration. The feeling that the natural increase of the population was not sufficient led in New South Wales to the appointment of the Birth Rate Royal Commission (1903). An outgrowth of that commission was a Federal Royal Commission on Secret Drugs and Cures which reported in 1907 and devoted much attention to the matter of artificial limitation of families. It was established fairly clearly by the first of these commissions that there was no natural cause predisposing to sterility in Australia, but that the desire for comfort conduced to a somewhat general artificial limitation of families. As a consequence of this commission some public opinion against the tendency to "race-suicide" was aroused; and certain administrative measures were adopted by the Customs and Police departments which sought to lessen the facilities for artificial limitation of families. It is a coincidence, if not a case of cause and effect, that from 1905 "the natural increase" of population in the Commonwealth steadily improved until 1914 when, as a consequence of the World War, there was a very marked decline. Possibly a healthier public opinion following on the report of the Birth Rate Commission was in part responsible. Other possible contributory causes were a great increase in material prosperity following upon federation, and an influx of immigrants from lands where artificial limitation of families was not so much practised. The natural increase per 1,000 of mean population in 1906-10 was 15.93, which was higher than that of any European country, except The Netherlands and Bulgaria, and compared with 11.58 for England and Wales. But in 1915-9 it had fallen to 14.99. Australia has a low birth-rate and a very low death-rate. Taking a pre-war year the Australian death-rate of 10.4 compared with 14.5 for England and Wales, 30.0 for Russia and 19.3 for France.

In regard to immigration Australian public opinion has undergone a marked change, due in the main to a fuller appreciation of the danger of leaving the lonely outpost of the Empire in the South Pacific so bare of population. There was for many years a desire on the part of the exceedingly prosperous working people of Australia to keep out immigrants as much as possible, lest a rush of population should cause a reduction in the wage rate or a lowering of the conditions of life. That desire survives in some quarters, and is still a force to be reckoned with in a country where the Labour voters have the controlling power in politics. But it is being recognized, by Labour leaders as well as others, that a great access of population is necessary to the safety of the country and need not affect the general prosperity of a continent which has a little over 5,000,000, and has room, at a low estimate, for 100,000,000 people. In the beginning of Australian colonization state-aided immigration brought a great influx of people to Australia who otherwise would never have been able to afford the expenses of the long journey from Europe. Since 1906 the policy of state-aided immigration has been reestablished in Australia, and was afterwards, though interrupted by the war, revived under Commonwealth direction.

On April 3 1911 the decennial census was taken in Australia, and the population ascertained to be 4,455,005, showing a rate of increase for the Federal decennium of 18.05% as against a rate of increase of 18.88 for the previous decennium. But while the annual rate of increase from 1901-6 was only 1.39% the annual rate of 14,362,40, to which natural increase contributed 74,324 and immigration 69,300, exceeding in one year by over 50% the total immigration gains of the previous ten years. Australia had thus "turned the corner" in regard to immigration, but the World War came as a



disturbing factor. During 1911-5 the Commonwealth gained 99,393 by immigration; during 1916-9, 24,016.

A preliminary census count of the census of 1921 gave the population of the Commonwealth as 5,419,702, an increase of 969,721 since 1911. In the individual states the figures were: New South Wales 2,096,393, increase 449,659; Victoria 1,530,114, increase 214,563; Queensland 755,573, increase 149,760; South Australia 494,867, increase 86,309; Western Australia 329,228, increase 47,114; Tasmania 213,527, increase 22,316.

The population included 2,751,781 males and 2,667,921 females. In Victoria there was an excess of females over males of 22,294. Full-blood aboriginals and the population of the territories are not included; the proportion of whites in the territories being insignificant. In accordance with these returns New South Wales would gain an extra seat in the House of Representatives, and Victoria lose one.

**Social Conditions.**—The Australian people are almost wholly British in character; 97.54% of the total are of British origin, 1.21% come from foreign European countries and 1.16% from foreign non-European countries. The average standard of education is high and illiteracy almost unknown. The wage rate is generally high. The cost of living in Australia compares well with the cost in most civilized countries. In 1911 the statistician to the Commonwealth Government, Mr. G. H. Knibbs, instituted an enquiry into the cost of living. Taking four sets of family budgets, (a) of families with £200 a year and over, divided into families of four members and under four members, (b) of families with less than £200 a year, divided similarly, he found that the average percentage of income spent on housing was 13.70, on food 29.30, on clothing 12.72, on fuel and light 3.46, on "other items" (including amusements, thrift, etc.) 40.82%. This last figure gives the best indication of general prosperity, i.e. of a substantial margin out of wages and salaries for non-essential outgoings. The percentage of income expenditure on food in working-class families in Australia was then 36%, as compared with 57% in the United Kingdom, and a general average of over 50% in all other countries for which statistics were available. The cost of living showed in Australia a lower increase consequent upon the war than in most countries. For example, taking 174 as the index number for Sydney in 1913, that index number had risen to 268 (not much more than 50%) in 1919.

The Australian birth-rate was 28.25 in 1913 and 23.78 in 1919. The percentage of illegitimate births to total births was 5.30 in 1919. The marriage rate (number of marriages per 1,000 of mean pop.) was 7.88 in 1919. The celebration of a marriage is more easily effected in Australia than in England. The facilities for divorce differ in various states, divorces being granted more readily in New South Wales and Victoria than in the other states. The total of Australian divorces in 1918 was 721.

A disquieting feature of Australian social life is the preponderance of the urban over the rural population. In South Australia more than one-half of the total population of the state (380,000 sq. m. in extent) is concentrated in the city of Adelaide. In Victoria 50% in New South Wales 41% of the total population is in one city, and in the whole Commonwealth 42% of the population is contained within six cities. The charm of the cities is great; the conditions in the "back country" are often hard. By cheap railway rates for the farmers' goods, by pushing such of the conveniences of civilization as are under state control as far forward as possible, and by other means, the states and the Commonwealth strive to counterbalance the call of the cities. But all effort seems to be in vain. The proportion of the urban to the total population is growing. In 1906 Sydney had 35% of the total population of New South Wales, Melbourne had 42% of the population of Victoria, and in the whole Commonwealth six cities held 35.49% of the population. Now the proportions have greatly increased as seen above.

**Public Health.**—Though part of Australia is within the tropics there is practically no tropical disease, and there is an absence also of small-pox, hydrophobia and other diseases which are known in some parts of Europe. The death-rate from all causes in 1919 was 12.8. It is the lowest death-rate in the world except one. Lately there has been a betterment in regard to the infantile death-rate, which the hot summers ruling over the greater part of the Commonwealth make the chief cause of public health anxiety. In 1901 it stood at 103.61 per thousand, in 1919 at 69.21 per thousand. The Commonwealth Government pays a maternity bonus of 15 for every child born of a white woman resident in Australia. All the states have public health organizations to deal specially with infant welfare. Apart from infantile mortality, the chief foes to human life in Australia are tuberculosis, cancer, diseases of the heart and violence.

**Education.**—The Australian system of elementary education is free, compulsory, undenominational and usually secular. Secondary education is not free, but a generous system of bursaries makes education to the stage of a university degree available to the poorest in most states. There is also a good system of agricultural and technical colleges. In no state is denominational religion taught in the state schools; but private denominational schools exist, being maintained especially by the Roman Catholic Church.

**Production and Industry.**—The early stage of the federation was marked by a severe drought which checked for a time the development of prosperity. From 1905 the growth of prosperity was very

great until the check given by the World War and another severe drought. The disturbance to economic conditions caused by that war takes away a great deal of the value of comparative figures. The following figures appear, as regards 1918, more favourable than they really are since the value of the £ sterling if expressed in goods had depreciated seriously since 1914. Total Commonwealth production: 1909 £174,195,000; 1913 £218,103,000; 1918 £298,669,000. Australia is chiefly a pastoral country and her pastoral products represent nearly a third of the total. Her exports alone from the pastoral industry in 1918-9 were valued at £37,624,791. Drought is still a serious enemy of this industry and the effects of recent droughts are reflected in the live-stock returns. In 1910 Australia had 92 million sheep. This fell to 69 millions in 1915, grew to 87 millions in 1918 and in 1919 fell to 84 millions. Cattle have done better and in 1919 had reached the highest record number, nearly 13 millions. Horses number 2½ millions. Agriculture, which in 1909 produced £41,000,000, in 1918 produced £58,000,000; and dairy produce and bee-farming, which in 1909 produced £15,000,000, in 1918 produced £34,000,000.

Mining keeps up a steady contribution to the national prosperity £23,000,000 in 1909, £26,000,000 in 1918. Gold production lately has been decreasing, silver and copper of increasing importance. Coal has improved both in quantity raised and in price realized.

The manufacturing industries of Australia progress with each year, and it is clear that the British and American manufacturer must reckon on strong Australian competition in Pacific markets. In 1909 the manufacturing industries produced £40,000,000, in 1918 £75,000,000, (i.e., added that value to raw materials).

In spite of the drain upon manhood and capital during the World War Australian industrial progress continued. Australia, under the influence of a strongly protective tariff, is entering each year on new fields of industry. In the iron and steel industry one new concern is producing 300,000 tons of steel a year. In shipbuilding Australian cost per ton produced is at the moment lower than that of Great Britain; in 1923 a protective duty of 25% is to be imposed on British ships and of 30% on foreign ships coming to trade in Australian waters. Australia is making a vigorous effort also to encourage the woollen textile industry, and there is mooted a project to give Federal Government assistance to raise a capital of £14,000,000 for textile mills. Easily accessible coal on the mainland and excellent water-power in Tasmania favour manufacturing development, and in many great industries the cost of labour in the Commonwealth is now less than in Great Britain. British manufacturers are in some notable cases establishing branch factories in Australia.

Forests and fisheries bring an amount of £7,000,000 to the Australian purse. But in neither case is there much progress. The timber resources are usually prodigally wasted; and until very recently there was no attempt at reforestation. The fisheries are not exploited in any systematic fashion, there being little or no deep-sea fishing or fish-curing. In both these matters, however, better things are promised in the future. In 1909 the Federal Government launched the "Endeavour," a vessel specially built to investigate and chart deep-sea fishing grounds. The "Endeavour" has since been engaged in the collection of information regarding the migration, feeding grounds, etc., of fish in the waters off the Australian coast, and it is hoped that the ultimate result will be the foundation of a great fishing industry. In 1912 the Australian Government offered bounties for Australian-cured fish. Nothing material resulted.

**Trade and Commerce.**—After federation the overseas trade of the Commonwealth increased rapidly. In 1901 the total was valued at £92,130,000; the recent figures have been—

	Imports	Exports	Total	Value per Inhabitant
1911	£66,968,000	£79,482,000	£146,450,000	£32 12s. 3d.
1913	79,749,000	78,372,000	158,321,000	32 19s. 2d.
1919-20	98,607,000	148,365,000	247,172,000	47 2

The bulk of Australia's trade is with Great Britain, and a preferential tariff treatment of British imports is designed to keep British as opposed to foreign trade. As a consequence of the war there was a very marked decline of British imports. The following figures of Australian imports will illustrate:—

Percentage from

Year	U.K.	British Poss'n's	All Foreign Countries (including U.S.A.)	U.S.A.
1901	59.47	11.22	29.31	13.80
1911	58.98	12.86	28.16	11.57
1919	37.10	22.15	40.75	27.29

This is chiefly a war result. Whilst British industry was to a large extent paralyzed, the United States and British possessions captured a bigger share of the Australian markets. But a slight (very slight) decline in British imports was noticeable before the war and after the granting of a preferential tariff. It is hardly reasonable to expect that British imports will ever go back fully to their old position in the Australian market. Australian exports to the United Kingdom showed a dwindling proportion of the total before the war. War regulations, confining the export of certain products to Great

Britain, temporarily arrested that decrease. Taking quinquennial periods from 1899 the first would show an average of 49.56 of exports to the United Kingdom, the second an average of 46.88, the third an average of 45.14. The war period 1914-9 showed an average of 53.46 %.

Australian trade with Asiatic countries develops steadily; exports to these countries were valued at \$4,500,000 in 1901 and \$19,009,000 in 1919.

**Communications.**—There has been a great railway development in Australia since the foundation of the Commonwealth. In 1901 the total railway mileage was 10,123; in 1910 it was 25,657. Nearly all the lines are owned by the Commonwealth, or the State Governments. In 1917 the Commonwealth-owned trans-Australian railway from Port Augusta to Kalgoorlie was opened, and the five capital cities of the mainland are now linked by rail. The distance between Perth and Brisbane, 3,474 m., is covered in less than six days. Another trans-Australian railway, crossing the continent from N. to S., is contemplated. Unfortunately there are four different gauges in use on Australian main lines in the various states: the question of the standardization of gauge is under consideration. The capital cost of the Commonwealth-owned railways had reached to £10,950,000 in 1919; revenue did not meet working expenses. The various state-owned railways by the same date had cost £213,971,000. On these working expenses absorbed 74.26% of the gross revenue, and the net revenue gave a return of 3.01% on the cost of construction. It has to be kept in mind that all the Commonwealth lines and some of the state lines are developmental railways built in advance of the settlement which would make them payable.

The Commonwealth adopted a policy of Government-owned shipping and of close control of private shipping. Up to 1912 Australia was content with navigation laws which sought to keep Australian coastal trade as much as possible for Australian ships and insisted that all ships engaging in Australian coastal trade should observe Australian conditions in regard to wages, etc. Some very flourishing coastal shipping companies existed under these conditions. But war conditions affected very seriously the transport by sea of Australia's exports and, though relief to one class of producers came through the action of the British Government in buying for a number of years the whole wool crop in Australia, irrespective of when it could be shipped to Europe, there grew up the idea that the Commonwealth did not get as good shipping facilities as if she had her own Government-owned lines. In July 1916 Mr. Hughes, then Prime Minister, bought for the Commonwealth 15 steamers, each of about 7,000 tons, and a local building programme for 48 vessels was announced, with further programmes for building in Great Britain and America. Subsequently the local building programme was cancelled as regards 22 of the vessels; the local building programme for steel vessels (24) was continued, and six of them were running in 1921. In addition the Commonwealth Government had 18 ex-enemy steamers and one ex-enemy sailing vessel under its control. In Feb. 1917, a Commonwealth Shipping Board was set up to control all Commonwealth shipping matters; it has two committees, one for overseas trade with headquarters at Sydney, and one for interstate trade with headquarters at Melbourne. It has, *inter alia*, powers to divert privately-owned interstate shipping to overseas routes. The enterprise has not been a success either as regards the State ownership of shipping or the close State control of shipping, and there are indications that it may be abandoned. The total overseas shipping entered and cleared in Australia in 1913 was 10,601,948 tons, in 1918-9, 6,180,486 tons. British ships were 73.53% of the total in 1913 and 78.90% in 1918-9. Two ports of Australia, Sydney and Melbourne, exceed in shipping tonnage entered the figures for all British ports except London and Liverpool.

**Finance (Public).**—The Commonwealth Government; which at its inception had a share of the customs and excise as its only great source of taxation, now collects customs and excise, land tax, probate duties, income tax, entertainments tax and special war taxes. Its revenue from taxation and from services was £21,741,000 in 1918-9 and £44,716,918 in 1918-9. The rate of revenue collected per head had increased from £4 9s. 3d. to £8 17s. 9d. The Australian, in addition to these Commonwealth taxes, has to pay state taxes. The average state taxation per head is £11 11s. 6d. and the total taxation per head £20 9s. 3d. Out of the customs and excise revenue collected by the Commonwealth a fixed sum of 25s. per head per year is paid to the states and the states impose their own income and land taxes, stamp duties and probate duties. Out of the Commonwealth revenue is met all defence votes and costs of Federal services.

The Commonwealth Government and the state Government both have power, and exercise it freely, to raise funds by public borrowing, but all the states except New South Wales admit some control on the part of the Commonwealth of their borrowings. The World War added hugely to Australia's debt. In 1919 the Commonwealth Government owed £226,000,000, of which £208,000,000 was held in Australia. The various states owed £396,000,000, of which £138,000,000, was held in Australia. The balance in each case was mainly held in the United Kingdom. Before the war it might be said that the bulk of the Australian debt, both Federal and state, was fully represented by revenue-producing assets such as railways. That could be said of the total (£337,000,000) in 1914 but not of the total in 1920 (£722,000,000), the difference being mostly represented by unproductive

war expenditure. Of the state debts a total of about £35,000,000 was due to the Commonwealth Government, and that sum should be deducted from the £722,000,000 to calculate the actual debt load on the Australian people. In 1910 the Commonwealth Government by an amendment of the constitution was given power to take over all the state debts and consolidate them into one Federal issue. The power had not yet been exercised in 1921.

A Commonwealth bank of issue was opened in 1912. Its operations showed a credit balance of £1,922,000 in 1919. It transacts bank business and has a "Savings Bank" section. It had issued notes to the value of £57,000,000 by 1920 and held a gold reserve of 41.17% against them.

**Finance (Private).**—There are 21 private banks trading in Australia, of which four have their head offices in London. In 1919 their paid-up capital totalled £35,666,000 and their reserved profits £23,543,000; their total liabilities £257,634,000 and their total assets £277,950,000. Depositors in savings banks numbered 2,945,000 (more than half the population) and the average deposit was £43 12s. 7d. or £25 per head of the whole population.

**Government.**—Under the Federal constitution the Commonwealth is governed by a governor-general appointed by the British Crown and acting on the advice of a Cabinet which is responsible to an Australian Parliament of two Houses. The Senate represents the states and is composed of six members from each state, elected for six years by the adults of the state voting *en masse* every three years to return three senators; the House of Representatives is about double the Senate in numbers (75), represents the people numerically, and is elected every three years by the adults of Australia voting in single-member electorates, which are approximately equal in population. The number from each state varies with the growth of population. The Australian Parliament can only act within the powers set forth in the constitution. The High Court is the final interpreter of that constitution and may veto any legislation, either of the states or of the Commonwealth, which is *ultra vires*.

POLITICAL HISTORY

The Commonwealth of Australia was formed in 1901 by the union of the six states of New South Wales, Victoria, Queensland, South Australia, Western Australia and Tasmania. The first Government of the Union was formed by Sir Edmund (then Mr.) Barton (born in N.S.W. 1849, d. 1920). Mr. Barton entered the N.S.W. Assembly as member for the university of Sydney in 1879. His enthusiasm was aroused for the cause of the Federation of Australia. After the death of Sir Henry Parkes he assumed the leadership of the Federal movement. The convention which framed the Federal constitution had recognized Mr. Barton's services by electing him as its leader. Now as Federal Prime Minister he called to his side the premiers of all the federating states; with one exception they responded; and this ministry of "all the talents" appealed to the people for support on a non-party platform.

**The Early Parliaments, 1901-7.**—The first Federal Parliament was however divided into three parties, that following Sir Edmund Barton, that following the Free Trade leader, Sir George Reid (born in Scotland in 1845, d. 1918), and the Labour party, under the leadership of one of the remarkable men of Australian public life, Mr. J. C. Watson. Born of poor Scottish parents in 1867 while on the voyage to Australia, Mr. Watson was in boyhood deprived of nearly all the advantages of education, but taught himself enough to become a printer. Sagacious, tactful, resolute, he came to the front in the Australian Labour movement and was elected first leader of the Federal Labour party. The success of the Labour party under his leadership at the polls was extraordinary. The first Parliament of the Commonwealth, divided as between the Government followers and Mr. Reid's Opposition party almost equally, had the Labour party holding the balance of power. This made a position of difficulty for the Government. The common-sense and moderation of Mr. Watson saved the situation to some extent. He gave a general support to the Government and assisted them in their most pressing tasks. Nevertheless the first Parliament was hampered by party fighting, the Opposition seeking to win the Labour party over to their side, and the Government being forced to postpone a good deal, to modify a good deal, in order to keep in office. Sir Edmund Barton was deeply disappointed. He had looked to a first

patriotic Parliament completing without any "scuffing on the steps of the temple"—to use his own phrase—the measures necessary for the stability of the Federation. He experienced a first Parliament in which party rancour was extraordinarily rife. He retired to accept a Federal judgeship, and Mr. Deakin (born in Victoria in 1856, d. 1910) took his place (Sept. 1903).

Mr. Alfred Deakin met the second Parliament of the Commonwealth in 1904 with his own following reduced, the following of the Labour party increased. In April 1904 Mr. Deakin went out of office and was succeeded by Mr. Watson. In Aug. of the same year Mr. Deakin gave his support temporarily to Mr. George Reid, and Mr. Reid's administration supplanted Mr. Watson's. This lasted through a long recess and a few days of parliamentary life, and in July 1905 Mr. Deakin came back to office with the support of Mr. Watson. Mr. Watson was at that time determined on resignation from political life as he could not keep pace with the extremist elements in the Labour party. But he was strongly convinced that a measure of tariff reform was necessary, and resolved to remain in Parliament until it was effected. The first Federal tariff had had to make concessions to Free Trade sentiment. The second tariff was completely protectionist, and introduced a new principle into Australian politics by granting a "preference" to British imports. At the third general election in 1907 the Labour party again improved its position, mostly at the expense of its allies.

Mr. Watson kept the leadership of the Labour party, and kept that party solidly behind Mr. Deakin, until the tariff was settled. Then he retired and Mr. Andrew Fisher took his place. Born in Scotland in 1862 Mr. Fisher was brought up as a coal-miner. He went to Queensland in 1885, entered the state Parliament and later the Federal Parliament. He had been included in Mr. Watson's Cabinet. Now, assuming the leadership, he very quickly gave Mr. Deakin notice to quit, and in 1908 formed his own administration. It lasted little more than six months. Mr. Deakin then formed a coalition with the remnants of the Free Trade Opposition, no longer led by Mr. George Reid but by Mr. Joseph Cook (born in England in 1860), and the Deakin-Cook administration came into office. One of its first acts was to send Mr. George Reid to London as a first High Commissioner for the Commonwealth; Mr. Reid, on assuming this office, accepted a knighthood. Mr. Cook, like Mr. Fisher, had been a miner. He entered the New South Wales Parliament as a Labour member, drifted away from his party and entered the Federal Parliament as a Free Trader. He now joined with Mr. Deakin to oust the Labour party from office, one ground of attack being their lack of proper sympathy with the cause of Imperial defence.

*Australia's War Forebodings.*—This was at the time of the European crisis over Austria's annexation of Bosnia-Herzegovina, when public interest throughout the British Empire was being stirred over the question of maintaining British supremacy at sea and of strengthening the hands of the Imperial Government in view of increasing international complications. New Zealand had promptly offered to provide a "Dreadnought" for the British navy. It was objected that Mr. Fisher had not done likewise. He claimed that his Imperial patriotism was not wanting, but that in his judgment more useful action could be taken by hurrying on with the creation of an Australian navy. This navy, he stated in a despatch to the British Government, would be organized and controlled by Australia in times of peace, but on the outbreak of war would automatically pass to the control of the British Admiralty. Amid bitter party wrangles the third Australian Parliament closed its life in Jan. 1910.

The general election of 1910 resulted in a victory for the Labour party under Mr. Fisher. The party captured a working majority in both the Senate and the House of Representatives. The decision which gave Australia's destinies completely into the hands of the Labour party (and that not the Labour party of Mr. Watson, but of Mr. Fisher—much more of a "party" man) was influenced very largely by negative considerations. The people disliked deeply the coalition of Mr. Deakin with Mr. Cook, who had before seemed to represent absolutely irreconcilable ideas in politics; and a vote for the Labour party was in many

cases a vote of non-confidence in the coalition rather than actually an endorsement of Labour policy. An indication of this fact was given a little later, when the Labour Government (May 1911) submitted to a direct poll of the people certain amendments of the Federal constitution, without which it could not carry out its Labour policy. These amendments sought (a) to give the Commonwealth Parliament full power to legislate with respect to trade and commerce instead of the limited power it had under the constitution (the limitation stood in the way of Federal legislation dealing with the conditions of labour); (b) to give the Commonwealth Parliament full power over all trading corporations; (c) to give the Commonwealth Parliament specific power to deal with the wages and conditions of labour and with labour disputes; (d) to give the Commonwealth Parliament power to deal with all combinations and monopolies. A further proposed amendment of the constitution was to give the Commonwealth Parliament power to declare that any business was a "monopoly," and, following such declaration, to acquire it, paying on just terms for any property used in connexion with it. By a majority of about 250,000 votes in a total poll of about 1,155,000 votes the people declared against these amendments of the constitution. Thus a Labour Government was left in office without power to carry out its Labour policy.

The Fisher Government soon cleared itself very completely of any suspicion of a lack of earnestness regarding the defence of Australia and the Empire. In 1909, whilst Mr. Deakin was Prime Minister, an Act of Parliament had been passed enforcing military training on all able-bodied male citizens. This enactment of universal service had not been opposed by the Labour party. Indeed their criticism was that the system proposed to be enforced was not thorough enough; and the Government of the day promised that an expert from Great Britain should be asked to report on the system. Field-Marshal Viscount Kitchener accepted an invitation to visit Australia, and his report came before the Parliament of 1910 with a Labour Government in power. That Government not only accepted all his recommendations but in some cases crossed his "t's" and dotted his "i's." There was established a system of universal training for military defence which Lord Kitchener guaranteed as adequate and which the Fisher Government enforced against various protests with a resolute courage. In the matter of naval defence the Fisher Government was equally firm in dissociating itself from any faltering policy. A Commonwealth navy came into actual being as a fleet unit in 1913 when the battle cruiser "Australia" ("Dreadnought cruiser" type) and the light cruisers "Melbourne" and "Sydney" arrived in Australian waters. The same year the King laid the foundation-stone in London of Australia House, the splendid headquarters of the Commonwealth High Commissioner. A further step in the organization of the new nation was the appointment of the Inter-state Commission which, under the constitution, has power to adjudicate on and administer all laws relating to trade and commerce. It acts, in a sense, as a commercial High Court. Among its powers is that of preventing any preferential or discriminatory rates on the state railways.

The general elections in 1913 were unfavourable to the Fisher Government, and Mr. Joseph Cook took office with a majority in the House of Representatives but not in the Senate. His Government kept office under very difficult circumstances almost until the outbreak of the World War. On July 30 1914 the governor-general dissolved both Houses of Parliament, and in the general election that followed the Labour party won a majority both in the House of Representatives and in the Senate. A proposal to form a "national" Government representing all parties was not successful and Mr. Fisher formed his fourth administration in Sept. 1914. He gave up the Prime Ministership shortly afterwards to become High Commissioner in London and was succeeded by Mr. W. M. Hughes, his chief colleague. Mr. Hughes (born in Wales in 1864) on first coming to Australia was forced to many strange shifts to make a livelihood. But entering the N.S.W. Parliament as a Labour member of the "extremist" kind he soon proved himself to have ability and

fighting force of a rare order. Though subject to weak health, and later handicapped by deafness, he fought his way to the front rank by sheer grit. Seldom loved, he was always feared. Coming to the head of the Government in war-time he had fine scope for his combative genius. He earned bitter hatreds as well as generous praise in Europe and in his own country from 1914 to 1921.

*Australia in the World War.*—The gallant deeds of the Australian naval and military forces in the World War cannot be separated conveniently from the general history of the campaign, and there will be noted here only the political and civil developments. Australia entered the war with an enthusiasm of patriotism which obscured for a time any open sign of the fact that there was a section of the population which reflected closely the opinions of the Irish Nationalist party. About a third of the Australian population is of Irish origin; of this third the majority were (and are) more Australian than Irish in their national outlook, but a fraction of them have always inclined to give a first place to their Irish sympathies. Some dignitaries of the Roman Catholic hierarchy (which is largely Irish in origin and in education) have done much to encourage this fraction. As the war developed and an opposition to the British cause grew up in Ireland there was an echo of this in Australia. It was never sufficient to stand in the way of a whole-hearted prosecution of the war; nor did Irish Australians as a class refuse to take their share of the war's perils. But it was sufficient to prevent in 1916 and again in 1917 the passing of a referendum to enforce conscription for service overseas because it was able then to enlist on its side a genuine Australian feeling, partly made up of an objection to compulsion as under the circumstances supererogatory, and partly arising from personal hostility to Mr. Hughes.

A full understanding of the Australian character is needed to reconcile some apparently conflicting circumstances from 1914 to 1918. At the outbreak of the war Australia had a fleet in being which was at once transferred to the British Admiralty and did most useful work in the Pacific and in European waters. There was never a suggestion to tie it down to home waters nor to limit its best strategic use as determined by the British Admiralty. On the military side Australia had instituted a compulsory National Defence system for home defence, and this system was far enough advanced to be of some use in the recruiting of an Australian army. But the nation relied, as did Great Britain at the outset, on voluntary enlistment for overseas service. There was a magnificent response to the call for volunteers. By the end of the year Australian forces had seized the German Pacific possessions, troops had been offered for service abroad and 31,000 had left Australia for Egypt. In 1915 the Australian Expeditionary Force went through the unhappy Gallipoli campaign, and in 1916 was taking a distinguished part in France and in the Near East. The number of Australian divisions serving abroad represented a full quota of its manhood (five divisions to represent five million people).

When in 1916 conscription was proposed, that section of the Irish Australian people which, following the unhappy course of events in Ireland, had become hostile to Great Britain, opposed it (as did some other sections of the people). Their influence was sufficient to defeat this proposal, partly because it was understood that Mr. Hughes, the Prime Minister, would resign if his proposal were defeated, and many wished him to resign; but chiefly because the Australians felt that—to use their own vernacular—"they were doing a fair thing, anyhow." Since, in all, Australia sent 320,682 troops abroad, and they suffered 317,953 casualties (58,961 killed) and incurred war expenditure totalling £288,000,000 it cannot be said that there was any half-hearted Australian participation in the World War, though the result of injudicious political action was at one time to give that impression. Indeed the Australian national character came out of the test of the war very well. The Australian troops, the "Anzacs" as they came to be known from the initials A.N.Z.A.C. (Australia-New Zealand Army Corps), won a splendid reputation for courage and steadfastness. The Australian civil population bore without murmuring the heart-breaking losses of the Gallipoli

expedition and the devastation—smaller as regards loss of life but more cruel in its needless sacrifice—of the outbreak of venereal disease following the location of their young troops near the stews of Cairo. When an Australian corps was formed in France under an Australian leader, Lt.-Gen. Sir John Monash, and did really conspicuous service in 1918, Australian pride knew no bounds. Lt.-Gen. Sir John Monash was one of the figures of the war. Born of Jewish parents at Melbourne 1865 he graduated at Melbourne University as a civil engineer. In 1887 he received a commission in the Australian militia as a lieutenant and thereafter took a passionate interest in military history and military science. At the outbreak of the war he was at first appointed military censor in Australia with the rank of colonel. Later he served throughout the Gallipoli campaign and in Egypt, and then as G.O.C. the Third Australian Division in France. Finally, in May 1918 he was given command of the Australian Corps. In this command he proved conspicuous ability and energy. His first operation at Hamel, July 4 1918, had the distinction of being made the subject of a special staff brochure by the British General Staff.

Sir John Monash tells his own story of the campaign in *The Australian Victories in France in 1918*. British military opinion of the Anzacs was described in "G.H.Q." by "G.S.O."

Australia has made generous provision for her ex-service men. Pensions payable for total disability range from £2 2s. to £3 a week according to rank, with extra provision for a wife and all children under 16. A totally disabled soldier with wife and five children gets £3 17s. 6d. a week. Ex-soldiers and sailors are helped liberally to reestablish themselves in civil life. Co-operating with the state Governments the Commonwealth Government has made available farming lands, and grants and loans for houses, working capital, etc.

Before the war German trade and industry had strong footholds in Australia, German shipping lines and German metal companies in particular. Indeed the Germans had almost a monopoly of the treatment of Australian base metal ores. On the outbreak of war, steps were taken to extirpate all German interests in Australia, and the legislation against enemy property, and for the internment of enemy subjects, was far more severe than in Great Britain at the time. The German had never been popular in Australia as a trader, and there was some reflection in the rigour of the special war legislation of old hostility to a people who came under the suspicion of "not playing the game."

*Australia and the Peace.*—Mr. Hughes as Prime Minister had during the war many political crises to face. His war attitude—which was ultra-vigorous—was very warmly approved in Great Britain by those who thought that Mr. Asquith's Government was somewhat slow in taking the necessary steps. This approval, expressed as it was with perhaps an excess of zeal, did not make things easier for Mr. Hughes with some Australians, who conceived the suspicion that he was "playing to the London gallery." No more deadly charge could be brought against a colonial politician than that. The Australian people are fervent in their Imperial loyalty, but they have always been jealous of "Downing Street interference" and somewhat suspicious of a London popularity for their leaders.

Internal dissensions forced a reconstruction of Mr. Hughes's Cabinet in Nov. 1916. Mr. Hughes and the Labour party drifted further apart and in 1917 he broke with them definitely, and, after an appeal to the country, formed a new ministry mainly from the ranks of the Opposition and including only three of his old Labour colleagues. A later appeal to the electors at the end of 1919 was destructive to the power of the Labour party (which was actively assisted by the "Irish party") both in the Senate and the House of Representatives, but brought into being a new group, "the Country party," which represents chiefly agricultural interests. Mr. Hughes formed a new Government in Jan. 1918, but up to 1921 it had had a somewhat precarious existence and had been subject to serious internal dissensions. None of these home political troubles, however, diverted Mr. Hughes from his campaign against the German enemy and against British elements which he considered to be not earnest enough

in their antagonism to Germany. He was in London for a long term during the war, and in 1919 was in Paris as the Australian representative to the Peace Conference. One result of the World War had been to define the status of the great British dominions as that of really independent nations under the Crown. Mr. Hughes at the Peace Conference took full advantage of this new status, and vigorously fought for his idea of a peace much more punitive in terms to Germany than that actually agreed to. He was always in opposition to Mr. Wilson, often in opposition to Mr. Lloyd George. He wanted from Germany a full indemnity covering all war costs. He objected to any authority being granted to the League of Nations over ex-German territories in the Pacific which, he contended, should be straightforwardly annexed to Australia. Curiously enough, in this attitude Mr. Hughes was much more vigorously supported by a section of the British public than by his Australian constituents. He was acclaimed by many of these latter, but, returning to Australia, did not find the nation united under his leadership. His Cabinet was afterwards in a constant state of crisis, and early in 1921 it was rumoured that he would give up the Prime Ministership and come to London as High Commissioner, an office which Mr. Fisher had just vacated. But Mr. Hughes attended the Imperial Conference in London in June 1921 as Prime Minister.

**The Constitution and the High Court.**—The Federal constitution, in safeguarding the Federal power from trespass by the states and the power of the states from trespass by the Federation, necessarily set up a system of conservative check. But the full extent of that check was only understood when a High Court began to interpret various statutes in the light of the constitution. Already a considerable amount of the legislation of the Australian Parliament has been declared *ultra vires* by the High Court. Some of the decisions affected political issues so deeply that it was sought to amend the constitution so as to facilitate "Labour" legislation, but this effort failed. The power to amend the constitution is subject to many safeguards. A proposed amendment must first have the approval of an absolute majority of both Houses of Parliament; it is then submitted to a poll of the people; and to pass must secure (a) a majority of the total votes cast; (b) a majority of the votes cast in a majority of the states. If the three largest states voted "Yes" and the three smallest states voted "No," though the total Australian vote was "Yes," the proposed amendment would still fail.

In 1906 the Australian Parliament had passed an "Excise Act" which was intended to enforce what was called "the New Protection." A high protective duty had been placed on agricultural machinery, and at the same time an excise duty on the same machinery manufactured locally, with the provision that the excise duty should be remitted if the manufacturers paid "fair wages." On June 26 1908 the High Court declared this Act invalid, on the ground that it was not what it purported to be—a taxing Act, but rather an Act to regulate wages within a state, a thing which the Federal power was not competent to undertake under the constitution.

The first two Australian Parliaments devoted much time to discussing a Federal Industrial Arbitration Act, which included in its control state railway servants. This inclusion was nullified by a High Court decision that it was an unconstitutional interference by the Federal power with the affairs of the states. In the Trade Marks Act the Australian Parliament gave trade unions the right to register what is known in the United States as the "Union label," a mark showing that certain goods were manufactured by trade-union labour only. The Australian High Court (Aug. 1908) set this part of the statute aside on the ground that such a "Union label" was not a genuine trade mark, and the proposal to register it as a trade mark was really a subterfuge to assume control of labour conditions which were outside the province of the Commonwealth.

Not only Federal legislation but state legislation has been vetoed. An Arbitration Act in N.S.W. had sought to give the widest powers of regulating industrial disputes. In a series of five judgments the High Court gave such a strict interpretation to the provisions of that Act that it was more than half destroyed. (The High Court is the only court of appeal in cases affecting the constitution, and is with the Privy Council an alternative court of appeal in all other cases.)

In 1911, and again in 1913, 1915 and 1919, proposals were submitted to referenda for amendments to the Federal constitution which would legalize for the future the Labour legislation which the High Court had vetoed: all were rejected. The Australian constitution, as interpreted by the High Court, remains a barrier against any great development of socialistic enterprise on the part of the Commonwealth Government. In its working the Australian constitution has proved the most conservative instrument of Government within the British Empire.

**Industrial Disputes.**—Australia has elaborate machinery in Commonwealth and state Arbitration Courts for the settlement of industrial disputes without strikes. But strikes are very frequent and

do grave damage to the development of the country. They are directed against the state as an employer as well as against private employers. The strike on the Victorian state railways in 1903 was followed in 1908 by a strike on the Sydney state tramways. Both of these strikes against state employers failed. New South Wales in 1908 altered its industrial arbitration system, and, this alteration being resented by the trade unions, various strikes followed. The next year (1909) more serious strikes broke out on the Broken Hill (N.S.W.) silver-mining and the Newcastle (N.S.W.) coal-mining fields. Stern measures were taken by the New South Wales Government to repress these strikes, and the leaders in the strike movement were arrested and some of them punished with imprisonment. In 1910 there were strikes of tramway employees at Perth (W. Aus.) and of transport workers at Adelaide (S. Aus.). In 1912 the tramway employees of Brisbane came out on strike because of a slight grievance against their employers (a private company). The leaders fomented a sympathetic strike on "syndicalist" lines, calling out the workers in every industry with the avowed object of preventing all business. Serious riots accompanied the strike. The state Government acted with decision, and the strike disorders were crushed and the syndicalist movement defeated.

The World War did not stop strikes. In 1914 and again in 1916 there were serious coal strikes. Working-days lost through strikes in successive years were: in 1913, 623,000; 1914, 1,090,000; 1915, 583,000; 1916, 1,678,000; 1917, 4,599,000; 1918, 580,000; 1919, 5,652,000. The losses in wages through strikes during the period 1913-9 were estimated at £8,500,000—big figures for a country of which the total pop. is only 5,000,000. The statistics as to the methods of settling strikes force the conclusion that the legal industrial arbitration machinery is not effective—of 460 disputes settled in 1919 only 38 were settled by the state Arbitration Courts and nine by the Commonwealth Arbitration Courts.

**The Tariff.**—The Australian tariff is protective, with a rebate on some of its rates for British productions. The first tariff passed in 1901 was mildly protective; the second passed in 1908 was more stringently protective but made a "preference" concession to British manufacture. Successive changes since have been always in the direction of higher protection, keeping the Imperial preferential element, and (in an Act of 1920) extending it to other dominions of the British Crown. In the attempt to quicken the growth of Australian production a system of bounties was instituted by legislation in 1907, 1912 and 1918. Bounties are paid on the local production of certain agricultural products (cotton, rice, coffee, cigar tobacco leaf, dried fruits, fibres, oil); of preserved fish; of iron and steel; of shale oils; of sugar, if grown by white labour; of combed wool or wool "tops" exported.

**Defence.**—When the Commonwealth Government took over the defence of Australia from the states in 1901 there existed for land defence in the various states very small forces of regular troops, used as instructional cadres and as garrisons for the forts; small forces of militia, enlisted under a voluntary system and paid for about 16 days of drill and camp training a year; further small forces of volunteers, not paid at all, and giving usually but scanty time to training. The total of these forces was 25,873, of whom a proportion could be counted as efficient. Naval defence, apart from the existence of various small craft, was entrusted to the British navy, and a yearly subsidy (up to £126,000) was paid to the British Admiralty on condition that a fleet of a certain strength was maintained in Australian waters and certain facilities given to Australians wishing to enter the naval service.

At first the Federation did little to disturb these arrangements. The fleet subsidy was continued and extended. The military forces were taken over as they were. But the Defence Act of 1903 gave indication of a new spirit. It made provision for the enlistment of all able-bodied males for defence service in case of war. An amendment proposed by Mr. W. M. Hughes, then one of the leading members of the Labour party, that this universal obligation to military service should be accompanied by a universal obligation to training for service, was rejected. But it was inevitable that in time the one should follow the other. Mr. Hughes constituted himself the parliamentary champion of compulsory training for service, and—assisted outside the House by the National Defence League, of which Col. Gerald Campbell, a volunteer officer of distinction, was the moving spirit—eventually secured the acceptance of the principle.

A series of Acts from 1909 to 1918 gave Australia a military system under which, with few exceptions, the whole manhood of the country is trained to the use of arms. Under this system, at the age of 12, a boy must begin training (chiefly physical culture) as a junior cadet. Training as a senior cadet begins at 14 and lasts until 18; it comprises drills equivalent to 16 full days a year. At the age of 18 the obligation to undergo adult training begins, and lasts until the age of 26. This adult training consists of the equivalent of 16 full days' drilling a year, of which not less than eight shall be in a camp of continuous training. In the case of the artillery and the engineers the training extends to 25 days a year, of which not less than 17 must be in camp. There are certain exceptions, including one making provision for those who have conscientious scruples against bearing arms; these however are trained for the hospital and ambulance services. The thinness of the population in some districts

forces another class of exemption; the residents of the far "Outback" cannot be economically mobilized for training, and for the present are left out of the scheme. A Staff College in the Federal Territory is provided for the training of officers, and its organization is on severely practical lines. Cadets are accepted after examination. The whole cost of their college training is borne by the army estimates, and parents are forbidden to supplement the messing allowance by private pocket-money. Even railway fares to and from the college when cadets go on holiday leave are paid by the Government; as are also all costs of uniform and equipment. A severe but not unwholesome discipline is exacted; the drinking of alcoholic liquors and cigarette smoking are both forbidden in the college. The normal course lasts four years and is followed by a tour of duty in England or in India, after which graduates are available for staff appointments in Australia and New Zealand (the latter dominion shares in the carrying on of the college). During the World War the course at the Staff College was somewhat modified and 158 cadets were specially graduated for service at the front. The college provides for 150 cadets.

As, after training, the citizen soldier passes into a reserve, the potential military resources of the Commonwealth in the future are only to be calculated by the total number of males of "military age," minus those who had been exempted from training. On the basis of the present population there would be 366,000 males between the ages of 18 and 26; 330,000 between 26 and 35, and a further 614,000 between 35 and 60. Exemptions, at a broad guess, might be 25%. The organization of the establishment is at present 90 squadrons of light horse, 52 batteries of field artillery, 93 battalions of infantry, and a due proportion of engineers and army service corps.

In regard to naval defence there was strong criticism of the subsidy policy at the very outset of the Federation. But that policy was warmly supported by the British Admiralty and the Imperial Defence Committee; and the impression was given that the only alternative to an Australian cash subsidy towards the British navy was no cooperation at all in the naval defence of the Empire. Indeed the early advocates of an Australian navy were met in their own country with charges of disloyalty to the Mother Country. But Australian public opinion steadily hardened on the subject. The British Admiralty was ultimately converted, in part at least. On Dec. 19 1907 Mr. Deakin, as Prime Minister of Australia, outlined a scheme by which Australia would devote the amount of the naval subsidy, then £200,000 a year to the building of an Australian fleet, under the control of the Commonwealth Government but trained to cooperate with the British navy.

The general anxiety as to the European situation in 1909 made the subject of Imperial defence of the first importance. Australia was represented at an Imperial Defence Conference in 1909, which showed a remarkable change of opinion on the subject of "local navies" on the part of the British Admiralty. They brought down to the Conference, as a substitute for an Australian subsidy to the British navy, a proposal for the building of an independent Australian fleet unit with the help of a British Treasury subsidy of £250,000. The Australian Government adopted the scheme in its entirety, except that it refused to accept the subsidy and decided to put the whole cost on the Australian taxpayer. Under this scheme Australia was to provide a fleet unit with a "Dreadnought" cruiser as its chief vessel.

In March 1911, at the request of the Australian Government, and at the close of a visit to Australia, Admiral Sir Reginald Henderson reported on the naval needs of the Commonwealth. His report was accepted, and it represents the present aim of Australian naval defence. In 1919 Admiral of the Fleet Lord Jellicoe visited Australia to advise the Commonwealth as to their naval programme in the light of the lessons of the war. In 1921 a special conference was held at Singapore to consider the Pacific naval position. It was announced by the British Admiralty early in 1921 that British naval policy (especially in regard to a battleship programme) would not be finally decided upon until after discussion with the dominions. Thus the wheel had come full circle from the British Admiralty attitude of 1907, which discountenanced any dominion naval action except a financial support for the British navy, to the decision that the British naval programme must not be finally settled without consulting the dominions.

The Australian naval organization has a naval college at Jervis Bay for the education of naval officers. The system follows that of Great Britain exactly except that all expenses of the cadets are met by the Commonwealth Government and parents pay no fees. There is also a training-ship at Sydney for the training of other ranks. The Australian navy is in charge, for the Empire, of the S. Pacific naval station. It has a fleet of 30 surface warships headed by the battle cruiser "Australia," six submarines, and various auxiliaries.

Australia's defence expenditure (naval and military) in 1905 was less than £1,000,000. In 1918-9 it was £87,270,000, and the estimates for 1919-20 were for £129,000,000.

The visit of the Prince of Wales to Australia in 1920 was marked by the most cordial demonstrations of loyalty and personal affection. An effort was made by the Irish party and an extremist Labour section to strike a discordant note. It failed completely. The Australian soldiers in France had been won by the Prince's qualities of courage, dutifulness and charm to what may be called without

exaggeration a devoted admiration. They gave the lead to Australian public sentiment in the welcome of the royal visitor.

### NEW SOUTH WALES

The area of New South Wales is computed at 309,472 square miles. The state has progressed rapidly since federation. The pop. in 1900 was 1,364,590 and in 1919 2,002,631. In 1908 New South Wales reestablished a system of state-aided immigration. The city of Sydney has shown a remarkable growth since federation, and in 1912 a "Million Club" was formed to foster the growth of the city to 1,000,000 inhabitants. Pop. (1921) 828,700.

Politically, New South Wales was the original headquarters of the Australian Labour party; its state Parliament is usually controlled by the Labour party and the Premier in 1921 was the Hon. John Storey, leader of the Labour party. At the time of the Union, New South Wales was the centre of anti-federation, and its hesitancy to throw in its lot with the other states caused some delay in realizing the Union. A certain anti-federal spirit persists, and it is shown in the fact that this state stands out from the Federal control of its borrowings. No state has benefited more from the Union, the effect of which tends to group most of the great industries of the Commonwealth around the New South Wales coal-fields. A recent development of great importance was the foundation of steel manufacture at Newcastle.

Besides Sydney (the greatest port of Australia and the chief entrepôt for the American, the Asiatic and the Pacific trade), New South Wales has notable cities in Newcastle—the centre of the coal-mining industry—Broken Hill, a great silver, zinc and lead-mining town in the far W. of the state; Tamworth, Bathurst, Goulburn, Wagga and Albury, pastoral and agricultural centres.

The governor in 1921 was Sir Walter Davidson.

### VICTORIA

Since Federation the pop. increased from 1,107,206 to 1,495,938 (1919). State-aided immigration was reestablished in 1908 and a vigorous policy of closer settlement has been adopted. Before the Union Victoria had established by a high protective tariff a lead in the manufacturing industries. That lead has now passed to New South Wales. Victoria is, however, developing with energy her agricultural interests, and has lately made good progress with intensive fruit-growing on the banks of the river Murray. The area under all crops in 1919 was 3,942,000 acres. The state has been more stable in its politics than most of its neighbours and is the centre of Australian Conservatism. As temporary seat of the Commonwealth Government, Melbourne (pop. 743,000), the capital of Victoria, is also the political capital of Australia, and the housing of the chief Federal departments there has given some impetus to the city's growth. Since the inauguration of the Federation it has been improved greatly in appearance by a scheme of tree decoration applied to the river banks and the chief streets.

The governor in 1921 was the Earl of Stradbroke.

### SOUTH AUSTRALIA

S. Australia has an area of 380,070 sq. m. and a pop. in 1919, of 468,104, having been relieved of the care of the Northern Territory. The state is facing the development of its "dry-belt," where wheat-growing has been found to be possible with a very low average rainfall. In 1901 the area under wheat was 1,743,452, in 1919 2,186,349 acres.

In politics South Australia has always been very progressive in spirit. It was the first state to enfranchise women, and most of the "social reform" legislation of Australia originated here.

The governor in 1921 was Sir Archibald William Weigall.

### WESTERN AUSTRALIA

The pop. was 331,660 in 1919. The state has had for many years a system of state-aided immigration. The backwardness in development of this, the largest of the states, is being met by a vigorous land settlement policy. In 1920 the state had 1,605,000 ac. under crop, mostly wheat. The gold yield is dwindling. In 1918 it was 876,512 oz. compared with 1,595,270 oz. in 1909. But W. Australia is still by far the largest producer of gold in Australia.

The governor in 1921 was Sir Francis Newdigate Newdegate.

### QUEENSLAND

The pop. was 725,220 in 1919; the state has progressed greatly since federation. Alone among the Australian states it develops its railways from several maritime centres instead of from the one capital city. The sugar industry is a great source of Queensland wealth, and some anxiety was formerly felt as to whether the "white labour" policy of the Commonwealth would not ruin this industry. That anxiety no longer exists.

Politically the state is one of the strongholds of the Labour party, and during 1920 its Labour Government was strongly criticized in Great Britain for passing an Act which was regarded as repudiating the conditions under which British capital had been advanced for pastoral development.

The governor in 1921, was Sir Matthew Nathan.



## TASMANIA

With a very mild climate, in which drought is unknown, Tasmania (pop. in 1919, 216,757) is destined to be the garden, orchard and small-culture farm of the mainland. A new source of wealth now being developed is that of the production of electricity from water-power. A great industrial future is promised from the utilization of the Great Lake water-power, and there has been talk even of carrying electric power by cables across to the mainland.

The governor in 1921 was Sir William Allardye. (F. F.)

**AUSTRALIAN LITERATURE.**—Australia's beginning was from a literary standpoint unfortunate. The primitive aborigines had no history and no legendary lore which, finding expression through some of the first colonists, might have added to the world's stock of romance. The exploring of the continent—the siege of the Blue Mountains with their baffling natural fortifications, the conquest of the great fastnesses of the sun on the dry inland plains—might have inspired an epic, but no one of the explorers nor of their contemporaries attempted more than a bare record. The sordid convict era inspired one book—*For the Term of his Natural Life* (1874), by Marcus Clarke—which is made notable by its subject rather than its treatment. The bushranging era inspired another—*Robbery Under Arms* (1888), by "Rolf Boldrewood" (T. A. Browne)—of which the same may be said. Those are the two master works of early Australian letters. Yet neither is distinctively Australian in the sense of showing a different outlook on life or a different sense of literary values, to that of the average contemporary English writer. The same may be said of the poems of Adam Lindsay Gordon, who wrote in Australia of Australian subjects from the standpoint of an English squire.

At a later epoch, when there was less promising material, there came the beginning of a characteristic Australian literature giving great promise which as yet has not been fulfilled. The people—bred from the wilder and more enterprising of English, Scottish and Irish stock, responding to the influence of the bountiful, sometimes fierce, sunshine, and to conditions of life which are singularly free from any bonds of convention and tend to the levelling of social conditions—have departed somewhat from the home type. They are gay and debonair, whilst a little inclined to be cynical, irreverent and vainglorious; enduring and brave, even to the point of being somewhat ruthless. The qualities of these new people, the Australians, begin to show in their literature, which is as yet more impressive in quantity than in quality. There are at least one hundred minor poets of some skill and originality of thought in Australia (with five million inhabitants), and nearly that number of prose writers of distinction—all showing to the close observer some signs to distinguish them from writers of the same class in Great Britain and in America. A hedonistic joy in life, a disrespect for authority, a wit tinged with cruelty, a freakish humour founded on wild exaggeration—those are the qualities which outcrop most often in exploring the fields of contemporary Australian literature. There is to be found, too, a tinge of mystic melancholy, a sense of bitterness—a loving bitterness—inspired by the harsh realities of life in the "bush" where Nature makes great demands on human endurance before permitting her conquest, but enslaves her winners by her very cruelty.

This modern Australian literature owed very much to one man—J. F. Archibald (1858-1919). He was of partly Scottish, partly Irish, partly French forbears, with a touch of Semitic blood. Editor for a quarter of a century of a notable Australian paper, he made it his mission to encourage young Australians to write of the life that was peculiar to Australia. He was a wit with a fine *flair* for a phrase; a sentimental cynic; and passionately Australian. Mainly under his aegis there came forward a young school of writers which included Henry Hertzberg Lawson (b. 1867), who has given in short stories and verse faithful, sometimes terrible, glimpses of the "bush"; Andrew Barton ("Banjo") Paterson (b. 1864), a singer of the rackets, horsey life of Australian sheep stations; George Louis Becke (1848-1913), who pictured South Sea Island life; Arthur Hoey Davis ("Steele Rudd," b. 1868), who writes broadly comic and yet sympathetic studies of life on the small farms of Australia; Roderic Quinn (b. 1869), and the late Victor Daley (both of

Irish extraction and giving in their verse two different and yet both characteristically Australian modifications of Celtic melancholy); Edwin James Brady (b. 1869), writer of sea songs; Ethel Turner (Mrs. H. R. Curlewis, b. 1872), English-born but Australian by education, a graceful novelist of Australian childhood; Bernard O'Dowd (b. 1866); Barbara Baynton, Mary Gaunt, James Francis Dwyer (b. 1874) and many others. Some of these owed much, some little, directly to Archibald and his newspaper. But without a doubt he was the chief founder of a new Australian literary movement.

Within the decade 1910-20 there was very little that was characteristically Australian in the literary product of the southern continent. An exception must be made for *The Sentimental Bloke*, by C. J. Dennis, a collection of verse which showed original qualities of humour and sentiment. A distinctively Australian literary magazine, *The Lone Hand*, faded away after a period of apparently vigorous life.

Australian letters suffer from diffused energy. There are numerous writers of some ability, but no commanding figure. The future holds out a hope of Australian work of the first rank, inspired perhaps by the "bush"—the mysterious Neolithic-age forests, hills and plains—perhaps by the giant work of the early explorers, perhaps by the extremely fluid social conditions of a young country full of self-confidence as it grapples with the old, old problems of civilization.

The Australian newspaper press reproduces with close fidelity British press characteristics. The Melbourne morning journals, the *Age* and the *Argus*, follow traditions which in the British islands survive only in Scotland and the provinces; the Sydney morning journals, the *Herald* and the *Telegraph*, are somewhat more new-fashioned, and are comparable with their London contemporaries. Practically all Australian papers record fully not only the doings of their own parliamentary and municipal bodies but also British political history and foreign affairs. A new note of progress has come into Australian journalism since 1910 by the foundation of a cable news agency as a rival to the old agency which for many years had a monopoly of foreign news service. (F. F.)

**AUSTRIA, LOWER** (see 3.1).—Lower Austria is bordered on the E. and N. by Hungary and Czechoslovakia; on the W. by Czechoslovakia and Upper Austria and on the S. by Styria. As the result of the losses of 1919 (Stadt-Felsberg and other places), Lower Austria extends over an area of about 7,639 sq. m. only. The pop. of the present Lower Austria was in 1910 3,525,094, but in 1920 it was reckoned at only 3,313,155 (434 per sq. m.). In 1910, 91.68% of the population were Roman Catholics, 5.26% Jews, 2.64% Evangelicals and most of the remainder belonged to the orthodox Greek faith. For administrative purposes, this territory is divided into 23 districts and 3 cities, the municipalities of which are autonomous, viz.:—Vienna, the capital, pop. (1920) 1,842,005; Wiener-Neustadt 35,000, and Waidhofen an der Ybbs 4,740. Other important towns are: Baden (pop. 8,698) and with its suburbs 21,095; Bruck an der Leitha 6,007; Schwechat 8,528; Korneuburg 7,736; Stockerau 10,324; Krems 13,595; Mödling 17,704; Neunkirchen 10,759; St. Pölten 23,061; Klosterneuburg 13,431.

Of the total area 96.3% is productive, and of the productive area 45.3% is arable, 35.5% forestal, 13.6% gardens and meadows, 3.7% grazing-lands and 1.9% vineyards. The neighbourhood of Vörsberg in Lower Austria is the chief industrial district of the new Austrian Republic.

The Wiener-Neustadt-Vienna canal is now no longer used. At Grönbach, near by, are the only big coal-mines now belonging to Austria. In the hill country to the E. are lignite deposits, now mostly on Hungarian territory, but partly in the Burgenland. Korneuburg is proposed as the starting-point of the projected Danube-Oder canal.

**AUSTRIA, UPPER** (see 3.2).—Pop. in 1910, 853,006; in 1920, 857,234 (185 to the sq. m.). For administrative purposes, this territory is divided into 15 districts and two autonomous municipalities, viz.:—Linz, the capital (pop. 93,473) and Steyr (pop. 20,234). Other important places are: Wels (pop. 15,427); Bad Ischl (pop. 9,695—the town itself 2,297); Gmunden

(pop. 19,564—the town itself 6,411). These figures are from the census of 1920. In 1900, 92.1% of the soil was productive and the productive areas included 38.1% arable; 20.1% meadow; 2.7% grazing land; 36.9% forestal and 2.2% gardens. The salt production of Upper Austria forms nearly 60% of the whole Austrian output.

Urfahr is now incorporated with Linz. The Pöstlingberg (1,762 ft.), a favourite resort, is connected with Linz by mountain railway. The pop. of Steyr increased by only 150 between 1900 and 1910 because of a decline in the iron industry, and the increase afterwards was due to the opening during the World War of a munitions factory which was later converted into engineering works.

**AUSTRIAN EMPIRE, 1608-18.**—The external designation of the state "unofficially known as Austria" (see 3.2) was for a long time unsettled.<sup>1</sup> The official name since 1867 for the Austrian half of the Austro-Hungarian Monarchy, as including the Habsburg possessions W. of the river Leitha, was "the Kingdoms and Territories represented in the Reichsrat" (*Die im Reichsrat vertretenen Königreiche und Länder*). It was cumbersome and but little calculated to arouse patriotic sentiments in its citizens. In the style of the Government offices this mass of territories was known as "Cisleithania." But the population was accustomed to talk of an Austrian Empire and of the Austrian Emperor, neither of which designations was quite happy or accurate. It was not till the World War that the dynasty felt the necessity for giving this group of countries a definite name and state arms of its own (as was done on Oct. 10 1915), the term "Austrian Empire" being adopted with the motive of giving "precise expression to the political unity of the Austrian territories" and "displaying tangibly the Austrian state as a unity." This proceeding might be compared to a death-bed baptism.

**Nationalities.**—The Austrian state had from its first origins always had a self-imposed political mission; its very name of origin, *Ostmark* (The Eastern March), marked it geographically as a bulwark, a gate-keeper, to defend Europe on the W. against encroachments from the E. From this original task arose a second, that of affording shelter to the fragments of peoples heaped together in inextricable confusion in this corner of the earth. With a few exceptions (Poland, Bosnia) it was through their free will that the Empire had come into being. The external legal forms of the union were marriages, inheritance and election; it was essentially the self-determination of the nations which brought them together. For 500 years Austria had fulfilled this double task fairly adequately; but in its third task, that of turning a mechanical combination into an intimate union, a symbiosis of the nationalities, the State failed. If it had achieved this as well, it would have given a model solution of the most difficult European problem; for Austria was Europe in miniature. There was no lack of attempts to do so; the methods varied, experiments were made as on a subject for vivisection; the object of the experiment suffers under it, but the method is perfected step by step.

Till late in the 18th century the nationality question remained untouched, and the Austrian peoples got on well with one another. Maria Theresa and Joseph II. were the first who thought it desirable to form these nationalities into a uniform nation coextensive with the state. The attempt failed, and the nationalities became self-conscious and split apart. The next stage was to take one people and train it as the representative *par excellence* of the State idea; and this people could only be the Germans. This attempt also failed; for the Germans were numerically too weak,

<sup>1</sup> For HUNGARY, as the other constitutional half of the old Austro-Hungarian Monarchy, see the separate article under that heading; also BOSNIA-HERZEGOVINA, and the articles on the different "succession states" which were formed on the break-up of the monarchy in 1918. As a matter of convenience, the account of Austro-Hungarian foreign policy (i.e. the Dual Monarchy as a whole) in 1909-18, dealing, from the Austrian standpoint, with the political developments resulting in the World War, is included as a final section under the present heading. The Austro-Hungarian army is dealt with under ARMY.

(Ed. E. B.)

and not vigorous enough in their methods (Bach period, 1850-60). A third experiment took the form of distributing over many backs a burden too heavy for one. In 1867 the Magyars accepted with alacrity this rôle in Hungary, the eastern half of the Dual Monarchy, while in the Cisleithanian territories the coöperation of the Poles was also sought. But this way too had to be given up, since even the smallest nationality would not allow itself to be absorbed, and during Taaffe's administration (1878) the idea came into favour of treating each nationality, and allowing it to grow up, according to its own idiosyncrasies; they were only to be restricted so far as the unity of the state rendered it absolutely necessary. What Austria desired to be was a state at once oscillatory and just, and it opposed no national demand which did not overstep the limits of state security; but this loosening of bonds unchained at the same time a number of national passions before which the state retired step by step.

As to the details, the following observations<sup>2</sup> may be made for the last phase of the empire which expired in 1918. The Germans had for long past given up all efforts at Germanization; their watchword was "maintenance of the national *status quo*"—that is to say, not an aggressive but a defensive principle. It was in Bohemia that they championed the principle most openly, where they were striving for national separation and protection against the Czechs of the territories which they had inhabited since the Middle Ages. The Germans of the Alpine lands were less ready to carry out the same principle in Tirol and the regions leading down to the Adriatic. The divided policy of the Germans led on all sides to their failure. In Tirol they lost even purely German territories; they were pressed back from the Adriatic; and in the lands S. of the Sudetic Mountains they were brought under a Czech national state, which inherited, with them, the problem of nationality.

The Czechs came under the sceptre of the Habsburgs after the battle with the Turks at Mohacs (1526), through an inheritance treaty confirmed by the vote of their Estates; an unsuccessful rebellion which they made in 1621 against the ruling house as protagonist of the counter-Reformation, brought them under the power of a ruthless conqueror, who wished to crush both their faith and their national independence. The reign of terror which followed the battle of the White Mountain was intended to remove all possibility of a fresh rising in the future. The Czechs rightly refer to this period 300 years ago when they describe themselves as a once oppressed nation. But in more recent times the position was different; the conquered race recovered, and a learned work, *Die böhmische Nation*, published in 1916 by the intellectual leaders of the nation, enlightens us as to their position. Dr. V. Zdeako Tobolka, leader of the "Young Czechs" (i.e. the party which had frustrated the efforts of the Old Czechs for a reconciliation with the Germans) produced this magnificent work in collaboration with 22 professors, artists, industrial leaders and writers of Czech nationality, supported by a national subsidy; it can therefore be accepted as a trustworthy Czech autobiography. This comprehensive book describes the collective life of the Bohemian "people, as the Czechs call themselves in contrast to their present appellation of the Czechoslovak state. It describes its material development, "its physical constitution and warlike prowess," of which they make a special boast, and after that its intellectual progress. In the sphere of education attention is drawn to the fact that 96.69% of the population of the Sudetic territories can both read and write: "Our education is, next to the German, the best organized and stands decidedly the highest" (p. 122). Next follow chapters on the literary renaissance of the nation, its progress in art, mathematics, chemistry and natural science; the magnificent development of agriculture, modern industry, commerce and finance; and in particular its flourishing self-government, "which will be exercised in the fullest freedom," and in which "the communal organization embodies in the highest degree the conception of self-government" (p. 234), and "the independent sphere of activity unlimited in its fundamental principle" (p. 235) in that "State control is exercised seldom and discreetly" (p. 236). "The control which is exercised over the land is in Czech hands since we possess a majority; the territorial authorities for the greater part belong to our nation" (p. 242). The influence of German culture is also remembered with gratitude. Of Palacky, the father of the nation, it says: "It was under the influence of German culture that Palacky was able to give a firm foundation to this conscious Bohemian ideal of his. To cut oneself off from external cultural influences, especially from German ones, he declared to be a mistake." Besides mentioning the encouragement bestowed by leading Germans like Goethe, Herder, Raumer, etc., on Czech poets and scholars, the book gives an appreciative account of the Emperor Joseph. The article by Jakubel on "the literary renaissance" says: "The Prague theatre, which had vegetated miserably up to now, developed under the reign of Joseph II. into a powerful instrument of culture. Joseph's

<sup>2</sup> As elsewhere throughout this article, the point of view is that of a fair-minded Austrian historian.

(Ed. E. B.)

enlightened despotism preserved to the Bohemian people at one stroke an astonishing number of distinguished and progressive spirits." In Prof. Kadner's article on education we read, "A new organization was first created by the famous May educational laws of 1869. It was the liberal-minded Germans who were instrumental in the first place in getting them passed, while the Slavs from the beginning took up—to their own disadvantage—a hostile or at least passive attitude towards the establishment of these laws." It should be difficult, after the copious details of this autobiography *de luxe* of the Czech nation in the year 1916, to speak of it historically as an "oppressed" nation of Austria.

The Poles were, together with the Ruthenians, the youngest Austrian nation; the repeated partitions of Poland since the 18th century brought them unwillingly under Austrian rule. After a short period of German government, which was highly beneficial to the country, Galicia received after the Constitution of 1867 an exceptional position which was gradually consolidated; the German officials were removed, and the Polish members in the Reichsrat (who represented 71 votes) held the balance between the parties, which brought Galicia, without any effort, great financial advantages at the cost of the other Crown territories. Up to the World War there was actually no articulate irredentism among the Austrian Poles; they were more contented than their co-nationals in Russia and Germany, and this explains their attitude of vacillation and indecision during a long period of the war.

*Ruthenians.*—Just as the Czechs had a majority in Bohemia, so had the Poles in Galicia; and they used their strength against the Ruthenians. The Austrian Government, being largely dependent upon the parliamentary aid of the Poles, could not stand out against them much on account of the far-reaching autonomy of the Galician Territorial Government. And so Russophil agitation found a fruitful soil, especially among the clergy and intellectuals. The Ruthenians, who were loyal to the empire, drew attention to the small degree of resistance offered to this agitation by the Polish authorities, who were interested in making the whole Ruthenian people suspect of irredentism. A grand campaign of agitation on the part of the Russian Count Bobrinsky, whose watch-word was that the Russian banner must wave over the Carpathians, though winked at by the Polish governor, led to a great political trial (Dec. 29 1913) for high treason of 180 Ruthenians who had been seduced by this agitator. It was not till towards the end of the war that the Austrian Government, in response to the wishes of the Ruthenians, began to come round to the idea of a separate status for Eastern Galicia; but it was then too late for such changes within the old territory of the empire.

*The Southern Slavs* were divided among four countries: Austria, Hungary, Serbia and Montenegro. Ban Jelačić, though loyal to the Emperor, had given expression to their aspirations towards unity as early as 1848; but Francis Joseph handed over the Croats and Serbs to Magyar domination (1867), and Dalmatia, the territory of the Austrian Croats, had been neglected by Vienna for years past; thus it was not till the years immediately preceding the war that it was rapidly developed by the construction of ports and railways and the encouragement of tourist traffic. The Slovenes, who inhabited Carinthia and Carniola, had less grounds for discontent, for the barren Karst had been afforested at the expense of the state; but though they were at the very gate of Serbia, they suffered from a shortage of meat, for Hungary obstructed the traffic in livestock in the interests of her great territorial magnates, and Austria bore the brunt of this. Vienna had for long been the hope of the Southern Slavs, and many of them had dreamed of a union under the Crown of Austria ("trialism"). It was not till this failed them that they turned towards Belgrade.

Of the three *Latin races*, Italian, Latin and Rumanian, national fragments were to be found in Austria. The Italians and Ladins, treated as separate in Switzerland, were in the Austrian official statistics treated as a single national group (like the Czechs-Slovaks and Serbo-Croats), but even then only totalled together 2.75% of the population of the empire. The claim set up by the Italians to a university of their own within the territory inhabited by them led to various controversies with the Germans and Southern Slavs. The Ladins, who formed about a quarter of this group, were not affected by irredentism, but looked rather towards German culture, and were to the end outspoken in their Austrianism. The Italian bourgeoisie of the towns, thanks to the force of attraction exercised by Italy, was all the more conspicuously irredentist, since the country population maintained an attitude of comparative opposition to this movement. Among the Rumanians, who inhabited three states (Austria, Hungary and Rumania), the desire long prevailed for union within the monarchy, and Austria would only have had to stretch out her hand to them; but the Magyars would not have it. Bukovina, the chief abode of the Austrian Rumanians, which they shared with the Ruthenians, offered the spectacle of a German administration in which without any compulsion German was the official language and also that of society, and neither efforts at Germanization nor language controversies were to be found. The Rumanians for years had proved themselves loyal to the State.

*Constitution.*—The establishment in Austria of universal suffrage in 1907 had as its aim the creation, in the place of the old

Parliament, which was crippled by the strife of nationalities, of a Chamber in which social and economic interests should prevail over national ones. It had been believed that it was property owners and intellectuals who placed the question of nationality above all others, while behind them stood a solid mass of working-people who were uncorrupted by nationalist chauvinism. The Social Democrats in particular had always insisted that the working-classes were necessarily international. The House now consisted of 516 members, of whom 221 were of Slav nationality, 177 of German nationality, and 87 Social Democrats, so that in every national controversy the latter could carry a decision in accordance with their principles. In spite of this, the calculation was defeated, for in Europe every true democracy at once becomes national, and hence the national problem infected the working-classes so soon as they won parliamentary power; the "International" split up into national groups, just as the bourgeoisie had done before it. Thus the motive force of nationality proved itself stronger than that of Socialism.

With the introduction of universal equal suffrage the stormy suffrage agitation came to rest, although one of its demands was unfulfilled, namely female suffrage for the Austrian House of Deputies. Active committees for women's rights were, it is true, set up in the territorial capitals. The election of a woman as a deputy to the Diet, which took place prematurely through their influence in Bohemia in 1912, was annulled by the governor as illegal. Women's activity was, for the rest, kept free from demonstrations and excesses. They were not, however, without quiet success, for these committees worked so intensively to create a public opinion favourable to woman's suffrage that immediately after the proclamation of the Austrian Republic in 1918 the vote was unanimously conceded to women, even the conservative parties agreeing to this.

It might have been expected that the concession of universal suffrage in the case of the House of Deputies would have led to the abolition of the class system of voting for the legislative bodies of the several territories and the introduction of an equal franchise, and also to the doing away with the three-class system of voting—established on the Prussian model—in the case of the election of municipal representatives. This was all the more probable owing to the fact that since the Constitution of 1867 there had been a certain analogy between the franchise for the Reichsrat, the Territorial Diets, and the elected commercial bodies. The Social Democratic party endeavoured, indeed, to remove the last remains of the old electoral privilege in town and country; but the urgent motion which they brought in to this effect as early as July 8 1908 broke down, owing to a not unfounded anxiety lest in the Crown territories of mixed populations one nationality should predominate too much over another. There was only a cautious and gradual extension of the right to vote in Diet and municipal elections in the several territories; and it was not till Jan. 20 1918 that the Government adopted the point of view of the Social Democrats, and promised to extend the principle of the parliamentary franchise, as established in the case of elections to the Reichsrat, to the communal elections also, but with reservations intended to guard against "the undesirable reaction of nationality in districts of mixed population." The principle of full equality of electoral rights in all three spheres was not carried out till the republic.

*Parliament.*—The activity of the Austrian Parliament can best be characterized as a continuous inactivity. The two great recurring "necessities of State," the budget and the authorization of the contingents of army recruits, regularly occupied a large part of the sittings; the budget was generally passed only in instalments in three or six monthly grants, and the Government was forced to adopt the practice of adjourning the obstructive House of Deputies and of providing for indispensable requirements in its absence by emergency decree.

The procedure of emergency decree was based upon Par. 14 of the constitution, which provided that: "When pressing necessity for such measures presents itself at a time when the Reichsrat is not sitting, they may be promulgated by imperial decree, in so far as they do not produce any lasting burden on the State treasury." The current administration could, it is true, be provided for by this means, but new commitments could not be entered upon. This resulted, indeed, in a fairly economical administration, but nothing could be done on an imposing scale. Par. 14 of the constitution also contained a safety valve which enabled the Government to carry on current business for a time without the cooperation of the Parliament. The Government repeatedly exposed itself to the charge of proroguing

Parliament in order to avail itself of these emergency paragraphs. This procedure has often been blamed as unconstitutional; but the excuse must be taken into account that a constitution which provides such an emergency exit must be prepared for use to be made of it. The situation was often such that Parliament would not work, and the Government was faced with the alternative of stopping the machine of State or availing itself of emergency decrees. Such occasions arose even before the war on an average every two years.

The Reichsrat's right of control was secured after the event by the fact that the Government was bound, the next time it assembled, to lay the emergency decrees before it within four weeks; and that it could refuse its ratification. But before the war the Reichsrat never exercised this right, and thus each time the Government's proceedings were whitewashed. It was only in 1917 that the emergency decrees promulgated by the Stürgkh Ministry at the beginning of the war failed to receive ratification, in retaliation for the suppression of trial by jury by a military trial and the extension over civilians of the jurisdiction of the military courts. The normal processes of criminal jurisdiction were consequently restored. On July 26 1914 Stürgkh closed Parliament altogether, and non-parliamentary absolutism reigned for three years. At last Stürgkh's second successor again summoned the Reichsrat; but since its six years' mandate was expiring, it was prolonged by a special law towards the end of 1918. On the break-up of the State in 1918 the German deputies of this rump Parliament assembled to form the constituent national assembly of German Austria, while in the Czechoslovak and Yugoslav states there were committees from which the German and Italian deputies were excluded, which proceeded to take measures towards forming states.

Organized obstruction of parliamentary business by a section of members has been, of course, not confined to Austria. But it was in Austria that this singular procedure was first brought to technical perfection; and it became an Austrian speciality. The reason for this was that every party had cause to fear parliamentary oppression at the hands of other nationalities, and this was why it was long impossible to reconcile the principal parties in the House to any effective remedy. It was not till the end of 1909 that this was achieved by a tightening of the standing orders.

The standing orders under which the business of the Reichsrat was conducted were, as the law originally stood (1867 and 1873), intended for a dignified assembly of which each member aimed at avoiding disturbances. With the extension of the suffrage and the growth of nationalist conflicts, the powers of the president were no longer sufficient, and he was unable to deal with the obstruction of even a small group. At last, on Dec. 17 1909, after an 86-hour sitting, entirely occupied with debates on emergency motions, an emergency motion as to new standing orders proposed by the Pollak group was passed; on the following day the Upper House adopted these resolutions, and on Dec. 29 1909 the new law was promulgated. By its provisions communications from the Government and the other House, and reports of commissions, had to take precedence of other business; further, the president could postpone to the end of the sitting formal motions, interpellations, emergency motions, and other obstructive measures. In the long run, however, even this palliative ceased to work; and accordingly on June 5 1917 a new stiffening of the standing orders was voted, which sufficed in effect during the later period of the Parliament.

**Language Question.**—There was no law regulating the question of what language was to be used in parliamentary debates. Every deputy might speak in his mother tongue; but custom had brought it about that, in order to be understood by the whole House, the members of Parliament spoke German. It was not till the Taaffe Government that it became a frequent thing for individual Slav deputies to speak in their own language. These speeches were generally not recorded by the stenographer; the Slavs protected themselves against this by gradually getting it accepted that polyglot stenographers should be appointed, that their speeches should be translated, and that they should be added as appendices to the parliamentary reports in the correct national language; finally it was resolved (June 1917) that all speeches should be verbally reported in the parliamentary reports, in the language in which they were delivered. The Upper House agreed, but expressed its misgivings as to such a polyglot report of proceedings.

**Administrative Commission for Bohemia.**—In June 1913 the Government considered itself justified by necessity of the State in adopting a measure which in many respects was held to be a breach of the constitution; it appointed a commission for Bohemia, the members of which were nominated by the State, to deal with the autonomous affairs of this country. Since the last election in the spring of 1908 the Bohemian Diet had been unworkable, eventually owing to obstruction on the part of the Germans, who saw themselves handed over hopelessly to the Czech majority, until a rearrangement of the voting groups (*curiae*) should afford them protection against Czech oppression. In 1913 the Germans sent in a petition that each nationality should pay the costs of its own educational and cultural institutions, as otherwise one nationality would have to bear the expenses of the other, and *vice versa*. When the Czechs refused this request the Germans responded with more obstinate obstruction. The representative assembly now ceased to work, and since no legal expedient could in consequence be found

by which legislation and current business could be carried on, the Government stepped in and appointed a mixed commission of Germans and Czechs, which should, as it were, administer the affairs of this country like a trustee for a person incapable of volition. This commission was admitted to have exercised its functions with impartiality as a matter of fact; but as a matter of form it stood on a weak foundation. The Germans were thereby deprived of their weapon of obstruction, and the Czechs lost the power of misusing their majority to oppress the Germans. The Czechs declared this to be a breach of the constitution; but the courts recognized the national commission as a measure of necessity justified in law. And so it subsisted until the break-up of the monarchy.

**Administration.**—The organization of the administrative system in the Austrian Empire was complicated by the fact that between the State and the purely local communal administration there intruded yet a third element, grounded in history, the territories (*Länder*). The State administration comprised all affairs having relation to rights, duties and interests "which are common to all territories"; all other administrative tasks were left to the territories. Finally, the communes had self-government within their own sphere.

To this division of the work of administration corresponded a three-fold organization of the authorities: State, territorial and communal. The State authorities were divided on geographical lines into central, intermediate and local, and side by side with this there was a division of the offices for the transaction of business according to the various branches of the administration. The central authorities, which as early as the 18th century worked together in a common mother cell of the State chancery, became differentiated so soon as the growing tasks of administration called for specialization; in 1869 there were seven departments, and in the concluding decade of the Austrian Empire there were set up Ministries of Labour, Food, Public Health and Social Care. Under these ministries came the *Stathalter*, whose administrative area had ordinarily the proportions of a Crown territory (*Kronland*); but the immense variations in area of the Crown territories made a uniform and consistent intermediate administrative organization practically impossible. The lowest administrative unit was the political sub-district (*Bezirk*) under an official (*Bezirkshauptmann*), who united nearly all the administrative functions which were divided among the various ministries according to their attributions.

Side by side with the State administration certain Crown territory administrations also existed in the 17 Crown territories, carried on by selected honorary officials, having under them a staff of professional officials. Many branches of the territorial administrations had great similarities with those of the State, so that their spheres of activity frequently overlapped and came into collision. This administrative "double track," as it was called, led, it is true, in many cases to lively emulation, but was on the whole highly extravagant. The evils of this complicated system are obvious, and easy to condemn. They can be explained, partly by the origin of the State—for the most part through a voluntary union of countries possessed by a strong sense of their own individuality—partly by the influence in Austria of the Germanic spirit, well understood by the Slavs, which has nothing of the Latin tendency to reduce all questions of administration to clear-cut formulae as part of a logically consistent system. Like the English administrative system, the Austrian presented a rich variety, a variety indeed so rich that it clamoured for drastic reform.

Bienert's last act as premier in May 1911 was the appointment of a commission nominated by the Emperor, to draw up a scheme of administrative reform. So early as 1904 Körber had declared a complete change in the principles of administration to be essential if the machinery of State were to continue working. After seven years of inaction, however, this imperial rescript was pitched in a far lower key. The continuous progress of society, it said, had made increased demands on the administration, that is to say, it was assumed that reform was not demanded so much by the defects of the administration but by the progress of the times, not because the administration was bad, but because life was better. It was an attempt to reform the administration without first reforming the State on equivalent lines. A reform commission without a programme naturally first occupied itself with reforms about which there was no controversy. After a year had gone by it drew up "Proposals for the training of State officials." After another two years it had indeed brought to light carefully prepared material for study, which was of great scientific value; but its proposals, though politically of importance, did not provide any basis for reform on a large scale. And so when the World War broke out the commission dispersed without practical results, leaving behind it an imposing array of folio volumes of great scientific value. It was not till March 1918 that the Seidler Government decided upon a programme of national autonomy as a basis for administrative reform, which was, however, never carried into effect.

**Education.**—The organization of the Austrian elementary schools was based on the principle of compulsory school attendance, free education, and the imparting of public instruction in the child's own language. Side by side with these existed private schools. The proportion of children attending private schools to those attending the public elementary schools in 1912 was 144,000 to 4.5 millions, i.e. a thirtieth part. Hence the accusation of denationalizing children through the *Schulvereine* must be accepted with caution. The



expenses of education were distributed as follows: the communes built the schoolhouses, the political sub-districts (*Bezirke*) paid the teachers, the Crown territory gave a grant, and the State appointed the inspectors. Since the State supervised the schools without maintaining them, it was able to increase its demands without being hampered by financial considerations. It is remarkable that the difference between the State educational estimates in Austria and in Hungary was one of 9·3 millions in the former as opposed to 67·6 in the latter. The elementary schools in Hungary were a State concern and a means of Magyarization, whereas in Austria their direction was left by the State to the nationalities. Thus in the former the schools were a means of denationalization, in the latter a means of national education. Under Austria, since everywhere that 40 scholars of one nationality were to be found within a radius of 5 km. a school had to be set up in which their language was used, national schools were assured even to linguistic minorities. It is true that this mostly happened at the expense of the German industrial communities, since the Slav labourers as immigrants acquired schools in their own language. The number of elementary schools increased from 19,016 in 1900 to 24,713 in 1913; the number of scholars from 3,490,000 in 1900 to 4,630,000 in 1913.

**Illiteracy.**—In proportion to the raised standard of popular education, further aided by the number of popular educational establishments which were springing up, and the university extension movement formed on the English plan, the proportion of illiteracy rapidly decreased. In 1890 the percentage of illiterates in the total population had been 28·5; in 1900 it had fallen to 22·7, and in 1910 to 16·5. As regards the several nationalities: among the Czechoslovaks in 1910 the percentage was 2·4; a little higher among the Germans (3·1) in consequence of the difficulties of school attendance in the Alpine territories; among the Italians 10·0, and among the Slovenes 14·7. The percentages were much higher among the peoples situated on the E. (Poles 27·4, Magyars 36·4, Rumanians 60·4, Ruthenians 61·0, Serbo-Croatians 63·7). It is their influence which explains the high average for the whole state.

**Universities.**—The higher educational establishments, which in the middle of the 19th century had had a predominantly German character, underwent in Galicia a conversion into Polish national institutions, in Bohemia and Moravia a separation into German and Czech ones. Thus Germans, Czechs and Poles were provided for. But now the sloven nations also made their voices heard: the Ruthenians, Slovenes and Italians. The Ruthenians demanded at first, in view of the predominantly Ruthenian character of East Galicia, a national partition of the Polish university existing there. Since the Poles were at first unyielding, Ruthenian demonstrations and strikes of students arose, and the Ruthenians were no longer content with the reversion of a few separate professorial chairs, and with parallel courses of lectures. By a pact concluded on Jan. 28 1914 the Poles promised a Ruthenian university; but owing to the war the question lapsed. The Italians could hardly claim a university of their own on grounds of population (in 1910 they numbered 783,000), but they claimed it all the more on grounds of their ancient culture. All parties were agreed that an Italian faculty of laws should be created; the difficulty lay in the choice of the place. The Italians demanded Trieste; but the Government was afraid to let this Adriatic port become the centre of an *irredenta*; moreover the Southern Slavs of the city wished it kept free from an Italian educational establishment. Bienert in 1910 brought about a compromise; namely, that it should be founded at once, the situation to be provisionally in Vienna, and to be transferred within four years to Italian national territory. The German National Union (*Nationalverband*) agreed to extend temporary hospitality to the Italian university in Vienna, but the Southern Slav *Hochschule* Club demanded a guarantee that a later transfer to the coast provinces should not be contemplated, together with the simultaneous foundation of Slovene professorial chairs in Prague and Cracow, and preliminary steps towards the foundation of a Southern Slav university in Laibach. But in spite of the constant renewal of negotiations for a compromise it was impossible to arrive at any agreement, until the outbreak of war left all the projects for a Ruthenian university at Lemberg, a Slovene one in Laibach, and a second Czech one in Moravia, unrealized.

### HISTORY

During the period from the assembly of the first Parliament elected by universal equal suffrage (1907) to the break-up of the Dual Monarchy, Austria itself had nine Governments under the following premiers:—

Baron Beck . . . . .	June 2 1906—Nov. 4 1908
Baron Bienert . . . . .	Nov. 1908—June 19 1911
Baron Gautsch . . . . .	June 26 1911—Oct. 28 1911
Count Stürzgh . . . . .	Nov. 3 1911—Oct. 21 1916
Ernst von Körber . . . . .	Oct. 28 1916—Dec. 20 1916
Count Clam-Martinits . . . . .	Dec. 20 1916—June 23 1917
Ritter von Seidler . . . . .	June 23 1917—July 25 1918
Baron Hussarek . . . . .	July 25 1918—Oct. 27 1918
Heinrich Lammasch . . . . .	Oct. 27 1918—Oct. 31 1918

All these ministries may be characterized as Cabinets composed of Government officials. Not one of their heads was drawn from the Chamber of Deputies. The Government was no longer the expression of the majority of the House, but had to be a non-party Government standing outside the House. An objective and non-party application of the laws, and equal rights for all nationalities, were in consequence the ever-recurring heads of their programme. From time to time, naturally, these Governments required a majority for the budget. They tried to arrive at it by negotiations with the parties, and by admitting to the Cabinet representatives of every nationality willing to cooperate. By this means the Cabinets acquired at least a measure of control over Parliament. A representative of Polish interests was generally to be found in every ministry, and usually too a minister of Czech and of German nationality. The political characteristics of these ministers are hardly distinguishable one from another; they all took their stand on a middle course of loyalty to the state and party impartiality. Beck, however, was held to be a shade more Slavophil, Bienert Germanophil, Gautsch dynastic, Stürzgh a Conservative Socialist; Körber and Seidler were mere officials, Clam-Martinits an old aristocrat, Hussarek and Lammasch Clericals. They regarded it as their principal task to bring about a compromise between the nationalities, and this again depended on the outcome of the German-Czech negotiations which were always being started afresh. In this none of these Austrian ministers succeeded.

**Beck's Ministry.**—With the carrying through of suffrage reform the Beck Ministry, which started in June 1906, had exhausted its strength. On June 17 1907 a promising speech from the throne opened the first universal suffrage Parliament and promised "to leave to the peoples as a secure heritage the integrity of their national territories"; "to solve the language question . . . on a foundation of equality of rights"; "to organize education with an equal consideration for all races"; "to introduce insurance against old age and infirmity . . . social reforms with regard to female and night labour, and an extension of the participation of the State in the exploitation of the coal-mines." Beck's next success was in reaching an understanding as to the language to be employed in Parliament. He also succeeded (July 12 1908) in bringing about an imposing procession in honour of the Emperor as an opening to the festivities of his diamond jubilee (Dec. 1848-1908). But apart from this celebration the second period of the Beck Ministry was attended by unfortunate incidents. On April 12 1908 Count Potocki, the governor of Galicia, was shot by a Ruthenian student. Then there was the Wahrmond affair. The Clericals started an agitation because Wahrmond, the professor of canon law at the university of Innsbruck, subjected the dogma of the Immaculate Conception to critical examination. They demanded from the Liberal Minister of Education, Marchet, that disciplinary measures should be used against him. The Minister endeavoured on the one hand to safeguard the principle of freedom of instruction, and on the other hand to avoid anything resembling a *Kulturkampf*. A general strike at the universities was averted by a compromise, by which Wahrmond was transferred from the pious land of Tirol to Prague, which was more than he had desired. In July a Pan-Slavonic congress took place at Prague, accompanied by anti-German excesses which had a serious sequel in Laibach. The Germans thereupon paralyzed the Prague Diet by means of obstruction, upon which the Czech members of the Beck Cabinet left it, and the prime minister, seeing himself abandoned by both Germans and Czechs, resigned on Nov. 14 1908. Shortly before this Beck had introduced yet another bill dealing with industrial insurance, to supplement the already existing sickness and accident insurance. The bill only received the assent of Parliament just before the break-up of the monarchy.

Baron Max Vladimír Beck (b. 1854) entered the service of the State in 1876, in 1900 became head of a section in the Ministry of Agriculture, in 1906-8 Prime Minister; in 1907 he got universal parliamentary suffrage accepted; he was responsible also for far-reaching measures of railway nationalization.

*Bismarck Ministry.*—Beck's successor Bismarck<sup>1</sup> attempted to rule by means of a Cabinet of mere officials, in which under-secretaries of State were appointed as temporary directors of their respective departments. Moreover the three chief nationalities, the Germans, Poles and Czechs, were each represented by a so-called national minister (*Landsmann-Minister*). Bismarck's policy was to confine himself in a purely objective spirit to the execution of the laws until such time as he had gradually gained the confidence of the nation. The Germans made their co-operation contingent on various conditions. They insisted that the Government should introduce proposals as to the official language of functionaries, for they feared a return of the procedure used by Baden, which by means of a Government ordinance had altered the received usage and upset the national balance of power; that in Bohemia the purely German sub-districts (*Bezirke*) should be included in German districts (*Kreise*), and in like manner the purely Czech sub-districts in Czech districts, so that there would then be a relatively small number of territories of mixed nationality, which would have to be governed bilingually; that minorities should be protected by law; and that in appointing to posts in the offices of the autonomous Bohemian territorial Government, proportionate consideration should be given to the Germans, attention being paid to the fact that in Bohemia more than a third of the population were German, and that they paid more than half the taxes, but that the Czech national majority had appointed more than 90% of Czechs and not even 10% of Germans in the Government offices. In purely German territories moreover it was claimed that only German officials should be appointed, just as in purely Czech territories the appointment of Czech officials was already uncontroverted and looked upon as a matter of course. Finally the old wish was put forward for a separation of nationalities in the representative assembly at Prague, in order that neither of the two nationalities should prepress the other in the internal affairs of Bohemia.

These German demands, which were exactly analogous to those formerly put forward by the Czechs, so long as they were still in a minority, now roused violent opposition among the latter. They called attention to the fact that the Germans in earlier days were deaf to such requests; they saw in them a "dismemberment of the country," and asserted that in the central public departments of Vienna, too, the Czechs did not occupy a number of official positions in proportion to their population. Serious excesses were now indulged in towards the German population and the German students in Prague, where, on the very day of the imperial diamond jubilee, the Government had to proclaim a state of siege.

The Reichsrat, which reopened under such conditions in Nov. 1909, stood under the threat of a paralyzing Czech obstruction. This time the Poles came to the rescue of the Government in its hour of need, by getting a form of standing order approved which rendered obstruction somewhat more difficult, and in this, curiously enough, they were helped by the Czechs; for obstruction had brought even them into an *impasse*, since their financial requirements had not been met. Thus the law for strengthening of the standing orders was carried through by an *ad hoc* combination of Poles, Czechs and Christian Socialists. But the freedom of parliamentary activity did not last for long. On Feb. 13 Bismarck went part of the way to meet the German demands by introducing a bill dealing with the rearrangement of the administrative districts (*Kreise*) in Bohemia. According to the statistical returns there were 139 administrative sub-districts where only Czech was spoken and 95 speaking only German, as opposed to only five bilingual ones. These 239 sub-districts, according to the bill, were to be grouped in 20 districts, 10 Czech, six German and four bilingual, in which provision was to be made for minorities throughout the whole land through official translation bureaus. This bill was intended to be a solution of the language question, which should take into account the actual conditions of the population as well as practical needs. The

<sup>1</sup> Baron Richard Bismarck-Schmerling (1853-1919) was made Minister of the Interior in June 1906; Prime Minister Nov. 1908-June 1911; and till 1915 he was Statthalter for Lower Austria.

excitement with which the Czechs opposed this measure was extraordinary. They brought about a scene in Parliament which ended in hand-to-hand fighting and assaults, whereupon the Government immediately closed the Parliament.

In other directions, too, Bismarck's period of government was filled with hostile nationalist proceedings. The Italian students desired to revive the question of an Italian university, which had come to a deadlock, and in Nov. 1908 set on foot a great demonstration at the university of Vienna, in which the usual fairly harmless fightday with sticks was replaced by revolver shooting. In spite of this, Bismarck, with the consent of the Germans, introduced a bill in Jan. 1909 which was to set up an Italian faculty of laws provisionally in Vienna.

At this time the Czechs were trying to gain a foothold in frontier lands which had hitherto been considered solely German. They alleged as a reason that two small country communes of Lower Austria, Ober- and Unter-Themmenau, had a mixed colony of Czechs and Croats; it was further advanced on their side that a considerable annual migration to Vienna took place, which became Germanized in the second generation, and so lost to their Czech nationality. Vienna, with over 100,000 Czechs, was actually the second largest Czech town. In reality a still clearer diminution of the Czech population of Vienna was noticeable; according to the census of 1900, out of 1,674,000 inhabitants there were 102,970 Czechs, i.e. 6.1%; in 1910, out of 2,030,000 inhabitants, 98,400 Czechs, i.e. 4.8 per cent. The Czech colonies in Vienna endeavoured, by means of the so-called "Komensky schools" (from the Czech form of the name of Komenius, the educationalist), to protect themselves against fusion with the indigenous population. The Viennese Germans saw in this a danger to the hitherto peaceful common life of the population of Vienna. On Sept. 3 1909 the Lower Austrian Diet, in opposition to these Czech encroachments, tried to establish German by law as the language of instruction in all the public schools of Lower Austria, in correspondence with the actual state of affairs hitherto. On Oct. 7 Burgomaster Lueger insisted that Vienna could only be a unilingual city, as otherwise she would have to speak nine languages; and on Jan. 18 1910 this resolution received the force of law. Analogous laws were promulgated in the three other purely German Crown lands.

After the Tauern railway had been built for the Alpine countries—without, it is true, any particular pecuniary help from the Polish part of the empire, which was known to be only passively interested—the Poles demanded a complete carrying into effect and extension of the waterways law, with a larger State subsidy. It was over these demands in connexion with the waterways, which the Minister of Finance declared to be impossible of fulfilment to the extent required by the Poles, that Bismarck's mainstay failed to support him; and on Dec. 22 he sent in his resignation, which was, however, followed by a renewed Bismarck Ministry, composed of Germans, Poles and officials. By means of this coalition the Ministry succeeded, indeed, in passing the military service reforms on April 24 1911 (reduction of the three years' service to two years, combined with an increase in the contingent of recruits); but this completely exhausted its parliamentary strength, and the first parliamentary suffrage Parliament ended with but poor results in the midst of unsolved national problems.

Since 1910 a meat shortage in Austria had made itself more and more felt, especially in the towns, owing to their rapid growth, the decrease of cattle-raising in the Alpine lands, and the reduction in the imports of Serbian meat through the anti-Serbian agrarian policy of Hungary. The Christian Socialist party, from being originally an urban party, had become partly an urban and partly a peasant party, and the Minister of Commerce, Weiskirchner,<sup>2</sup> who had come from its ranks, had not

<sup>2</sup> Richard Weiskirchner (b. 1861 in Vienna) entered the municipal service in 1883 and became in 1903 president of the town council; 1909-11 Minister of Commerce; 1912-8 Burgomaster of Vienna; a deputy from 1896 onwards; and in 1907 president of the Chamber of Deputies. He was a disciple of Lueger, a Christian Socialist, and framed a new municipal statute and associations based on the Christian view of society.



only to reckon with the opposition of Hungary, but also to pay particular attention to the peasant voters, in the question of buying meat abroad and importing frozen meat from the Argentine. On this account, especially after the death of Lugger (on March 10 1910), a dominating personality who had held all parties together, opinion in Vienna and other towns turned against the Christian Socialists, who were accused of refusing all active measures of relief. Thus it happened that the elections to the Reichsrat in July 1911 were characterized by a temporary coalition of the German Liberals with the Social Democrats against the Christian Socialist party; this led to heavy losses on the part of the latter, especially in the towns. In Vienna especially they lost every seat at one blow, by which means Weisskirchner found himself deprived of all parliamentary support. He resigned, and with him the head of the Cabinet; all the ground had slipped from beneath his feet, and on June 19 1911 Bienenrd resigned for good.

**Gautsch Ministry.**—The Bienenrd Government was succeeded by that of Baron Gautsch.<sup>1</sup> He too could attempt nothing more than to take up as objective an attitude as possible above parties. His first task was to try to set in motion again the negotiations for a German-Czech compromise in Bohemia. The Czechs, however, had realized that at need they could get along without a Diet, and they began once more their encroachments in Vienna. They opened a Komensky school there without proper authorization, and when this was closed by the municipal authorities, they organized a demonstration of Czech women, who crowded with their children into the Parliament House. Shortly before this the protests of Hungary had succeeded in procuring the rejection of a cargo of Argentine frozen meat which had been destined for Vienna. The fury of the Viennese found expression in violent demonstrations, in which, for the first time, employees of the State took part in uniform, among them employees of the State railways and of the post-office, Gautsch, who was a convinced upholder of the principle of State authority, had recourse to severe measures of punishment and discipline, which had as their result a revolver attack on the Minister of Justice from the gallery of Parliament.

On Oct. 28 somewhat unexpectedly the prime minister resigned, partly because this series of unfortunate incidents had shaken the Emperor's confidence, partly because his secret efforts to persuade the Czechs to join his Cabinet had made him suspect to the other parties. But the Czechs not only demanded two Czech ministers, but also a number of headships of departments and councillorships in each department. This would have led to an introduction of the national divisions into the central administration, and if similar claims were put in by other nations the principle of a purely objective Government transcending nationality would have been done away with. So Gautsch would have nothing to do with it.

**Stürgkh Ministry.**—Count Stürgkh (b. 1859), the Minister of Education, was next entrusted with the formation of a Cabinet. He composed his Cabinet of colourless officials and confessed adherents of the various nationalities. His programme was to be an honourable mediator in the German-Bohemian quarrel, to extend the railway system, and to satisfy the wishes of the Poles in the waterways question by an expenditure of 73.4 million *kronen* on canal construction in Galicia, to which Galicia was to contribute only 9.4 million *kronen*, the State finding the other 64, and by an expenditure of 125 millions on river improvements, 99 of which would be contributed by the State.

Early in Stürgkh's Ministry prominence was taken by the Catholic marriage question. While in Austria the marriage of non-Catholics could be dissolved, so as to make a new marriage possible, paragraph iii. of the civil code provided that "the tie of a valid marriage between Catholic persons can be dissolved only by the death of one of the parties. And this shall be the case even when only one party was attached to the Catholic religion at the time of the conclusion of the marriage." Thus Catholic and mixed Catholic marriages were indissoluble even in the

<sup>1</sup>Baron Paul Gautsch von Frankenthurn (b. 1851) had been Premier and Minister of the Interior, 1897-8, and Premier 1904-6.

event of a change of thread. The desire of numerous divorced persons for a change in the law which prevented their remarriage was manifested in repeated demonstrations before Parliament; especially in that of Dec. 1911, in which it was asserted that the lives of half a million divorced wives were affected. In spite of the reform of the civil law in other respects (June 1 1911) these provisions remained in force until the republic. Owing to the opposition of the Christian Socialist party, they were even then not abolished; but they were relaxed by numerous dispensations in individual cases.

It was while Stürgkh was Austrian premier that the World War broke out (see under FOREIGN POLICY, p. 327). At the beginning of the war the attitude of the nationalities of the Austrian Empire was somewhat unexpectedly loyal to the state. The immediate cause of war—the murder of the heir to the throne—had profoundly impressed all the Austrian peoples, and the belief that efforts were being made from without to destroy the old empire produced among them a strong reaction in favour of its preservation. Enrolment in the army proceeded everywhere without friction, and much more expeditiously than the military authorities had expected. It was only to be expected that the Germans, whose very existence was in question, should show themselves to be patriotic. But it was somewhat surprising that at Prague, after the declaration of war, Germans and Czechs sang *Die Wacht am Rhein* together in the streets, and the burgomaster, a Czech, made a speech in German before the town hall in which he called for cheers for the Emperor William and the fraternization of Germans and Czechs. On Oct. 24 1914 the Czech Union solemnly declared: "It is true that we have been against one Government or another, but never against the state." On Nov. 15 the Czech parties in Moravia issued a patriotic manifesto. The procedure of the Poles was similar; all the Polish parties united in a joint central committee which issued a manifesto in favour of performing their duty to the state (Aug. 15). On Aug. 27 the Ruthenian Metropolitan, too, issued a protest against "taarism," and in like manner the Ukrainians protested (Nov. 1) against Russian oppression of freedom of conscience. On Nov. 23 30,000 Rumanian peasants of the Bukovina got up a great manifesto in favour of the emperor and the empire, and on Dec. 1 patriotic protestations from the Rumanian Club followed. These proclamations on the part of all the Slav peoples of Austria proved that imperial sentiment was more deeply rooted than Austria's enemies had believed.

These evidences of patriotism continued for a long time during the war; even after Italy's declaration of war the majority of the Italian deputies in S. Tirol issued a loyal declaration "in the name of the overwhelming majority of the population," as they asserted (June 14 1915). On the other hand the efforts made for years by Pan-Slav idealists, Russophil agitators, Serbian propagandists and Italian Irredentists, were naturally not without effect. Isolated instances of relations being established with co-nationals in the enemy camp were recorded from the beginning. The question was repeatedly raised as to why the prime minister did not take advantage of this patriotic spirit to obtain a corresponding parliamentary demonstration; but it had surprised him, as it had many, and he shrank from the serious responsibility which would have resulted if the experiment had turned out badly; the aged Emperor's need of quiet, and the conviction that the Reichsrat, if summoned *ad hoc*, would, as for so long before, be of no active use, also played their part. The population had not been consulted as to the declaration of war, and their opinion was no more listened to now; but by giving up the cooperation of Parliament the prime minister at the same time abdicated his power in favour of the military authorities. Since there was no longer a Parliament, or any personal immunity, the military authorities established unlimited police rule, which seemed to be obsessed with terror of its own citizens; anyone who seemed to them suspect was subjected to internment in concentration camps. This ruthlessness towards their own citizens, who were arraigned before military courts in trials for high treason, stood in curious contrast to the considerate treatment of "enemy aliens," who were comparatively little molested. For example, even many

months after the beginning of the war advertisements were to be read in all the papers, in which English and French people offered to teach languages or instruct children even in English and French, stating their nationality and address—a proof that the authorities did not put any particular difficulties in the way of these foreigners, and that the people did not take advantage of knowing their addresses to molest them.

The political impotence of the prime minister was plainly evident in the military proceedings against Kramarz, in which Stürgkh shook hands with the accused and gave evidence in his favour, but without being able to avert the death sentence passed by the military court, though he did at least prevent the execution of the sentence.

During the later part of the Stürgkh Ministry it is no longer possible to speak of an internal policy, for the military alone ruled. Towards the end, however, Stürgkh was actually endeavouring to bring about a reassembly of the Reichsrat, when he was shot by the Independent Socialist Dr. Friedrich Adler (Oct. 21 1916).

**Körber Ministry.**—The object of the murder of Stürgkh, namely, to lead to a powerful demonstration in favour of the summoning of the Reichsrat, was not attained; at a meeting held between some deputies and members of the Upper House (Oct. 23 1916) no definite proposal to this effect was brought forward, and the Körber Ministry, which was summoned on Nov. 1, ruled during its eight weeks' period of activity without Parliament. On Nov. 14 Körber set up an office for food control (*Volksernährungsamt*) which later became the Ministry of Food (Jan. 1917). Little else was done; the approaching death of Francis Joseph (Nov. 21) prevented any far-reaching plans. When the worn-out old Emperor was succeeded by an immature boy, the serious, positive and somewhat "schoolmasterish" Körber did not strike the right note with him. Charles I. could not forgive Körber for prevailing upon him to promise to take the oath to the constitution, since the constitution was no longer tenable and Stürgkh had already prepared constitutional amendments; on the other hand Charles's assumption of the supreme command of the army was opposed to Körber's taste. When Körber declined to carry through the *Ausgleich* with Hungary without consulting Parliament, and made it a question of confidence the young Emperor on Dec. 20 1916 lightly dismissed his best adviser.

**Clam-Martinitz Ministry.**—Körber's successor, Clam-Martinitz,<sup>1</sup> who belonged to the violently Czech feudal nobility, tried to form a national coalition Cabinet, including two German politicians. The political event of the moment was President Wilson's note (Dec. 11 1916) and the Entente's answer (Jan. 12 1917) as to the liberation of the "oppressed" peoples of Austria. It called forth sharp counter-manifestoes on the part of those who were to be "liberated." A resolution adopted unanimously on Jan. 17 1917 by the Croatian representatives proclaimed, as a condition of the national existence and the cultural and economic development of the Southern Slavs, that they should remain under the House of Habsburg. The Czech Union rejected, by a unanimous resolution of its governing committee, the suggestions of the Entente, as being insinuations based on erroneous premises, and deprecated by a reference to their secular allegiance "the interference of the Entente Powers" (Jan. 23 1917). Koroschek, the Slovene leader, wrote to the minister in the name of his party that "these hypocritical assurances have called forth nothing but indignation among the Southern Slavs" (Jan. 1 1917). The Rumanian Club made a similar declaration on Jan. 24.

The hope of achieving parliamentary coöperation on the basis of such loyal declarations as these soon vanished. The Germans demanded, as a condition precedent to the effective participation of their nationality in the affairs of the state, an alteration of the constitution by imperial ordinance (*Ohfroh*), which should define

the boundaries between the nationalities in Bohemia, rearrange the districts (*Kreise*) accordingly, declare German to be the language in which the business of the Reichsrat was to be conducted, and lay down more stringent rules of procedure. The Slavs, on the other hand, demanded the "unconditional" summoning of Parliament. The Germans yielded, and the Reichsrat met on May 31. Both the Southern Slavs and Czechs immediately made constitutional declarations; the former demanded a national union of the Southern Slavs, the latter a territorial union of the lands S. of the Sudetic Mountains, while the Germans opposed any transformation of the monarchy into a federal state. In the face of this uncompromising display of opposition there could be no hope for the Coalition planned by Clam-Martinitz for the creation of a new Austria, and on June 19 he resigned.

**Seidler Ministry.**—On June 24 1917 the Emperor appointed as prime minister his former tutor, the Ritter von Seidler,<sup>2</sup> who summoned a Ministry of mere officials, just to carry on business for the time being; any constitutional reorganisation was still postponed. On July 2, on the occasion of the Crown Prince's birthday, the Emperor proclaimed a wide measure of amnesty, in which on July 10 even Kramarz and his confederates were included. This precipitate action aroused the mistrust of the Germans, and, in view of the ambiguous attitude of the prime minister towards the Czechs, led to a vote of censure being passed at a meeting of the German national council at Prague on July 15.

Seidler now resolved to undertake the reconstruction of the crumbling body politic, with a reorganized Cabinet (Aug. 33 1917). A great economic and social programme was announced, including the extension of waterways, the exploitation of electricity, an improved system of communication, industrial insurance, and a department for public health. Politically the organisation of the state on the fundamental principle of national autonomy was to follow; he hoped to get round the nationalist obstacles in Bohemia by a rearrangement of districts with local delimitation according to nationality. This bold plan met with no success; the economic programme in particular did not come into force; it was an empty promise, which was not taken seriously. But the political programme, on the other hand, let loose a violent attack of the Slav nationalities on the state. The Polish committee, which had been formed on a political basis, was dissolved after unprecedentedly stormy negotiations, due to discontent at the cession of Chelm (Kholm) to the Ukraine; the Poles threatened the rest of Austria with a boycott of food, and abstained from voting on the budget. The action of the Czechs was even more dangerous to the state; on Jan. 12 1918 a meeting of their deputies at Prague unanimously accepted a resolution to the effect that the Bohemian question was to receive an international solution at the Peace Congress. Seidler regretfully pointed out in Parliament on Jan. 22 that this resolution was totally opposed to that of May 1917, which could still be reconciled with the fundamental conceptions of patriotism. The Germans rejoined with a demand for a province of their own, German Bohemia, separate from Czech-Bohemia (Jan. 22). Similarly the Ruthenians demanded that East Galicia should be erected into a separate Crown land under the name of the Ukraine (March 3). Since the Northern and Southern Slavs had absented themselves and the Poles were in opposition, the Reichsrat was adjourned (May 3), and the Germans now again demanded the grant of a revised constitution, with German as the language of State, a special status for Galicia and Dalmatia; access for the Germans to the Adriatic, and the partition of Bohemia. Seidler granted indeed a rearrangement of districts in Bohemia (seven Czech, four German and two mixed); but he could not make up his mind to go further, and tried the expedient of summoning a fresh Parliament on June 16. But the day before

<sup>1</sup> Count Clam-Martinitz (b. 1863), an hereditary member of the House of Lords, and chairman of the Committee of Privileges in it, had been head of the Ministry of Agriculture from Oct. 31 1916; up to June 23 1917 he was Prime Minister, then Governor of Montenegro till 1918.

<sup>2</sup> Ritter Ernst von Seidler (b. 1862 at Schwechat, near Vienna) was secretary to the Chamber of Commerce in the mountain town of Leoben; then an official in the Ministry of Agriculture, and from June 1 1917 Minister of Agriculture; he was also a university reader in constitutional law.

the Czechs had set up a national committee, with Kramarz at its head, which adopted the programme of "a Czechoslovak State sovereign and independent." They proposed the impeachment of the minister responsible for the nomination of the chiefs of the districts, and declared that they would take no part in revising the constitution. His plans having thus been completely shipwrecked, Seidler resigned on July 22 1918.

**Hussarek Ministry.**—Hussarek,<sup>1</sup> who was appointed prime minister on July 24, declared his programme to be parliamentary government, with reconciliations of the nationalities, and constitutional and administrative reform. The Czechs, however, declared that so far as they were concerned, nothing had been altered. Hussarek got through a six months' provisional budget with the help of the Poles against the votes of the Ukrainians, a proof that he had shelved the partition of Galicia. Immediately afterwards the Reichsrat adjourned for the summer holidays (July 26), without having ventured on any steps towards the solution of the great problems of State.

The process of dissolution advanced rapidly, when England on Aug. 17 recognized the Czechoslovaks as an allied nation; to which the Austrian Government replied with the declaration that no such state existed, but only individual traitors. In a communication to the press on Sept. 4 Hussarek insisted that there were no oppressed peoples in Austria, that on the contrary her constitution assured to the several nationalities a status of equal rights like that of no other state on earth, and he gave a warning against its destruction—a vain appeal to reason. On Sept. 18 the Czech National Council had already imposed some taxes. On Oct. 1 Hussarek again gave the Reichsrat a chance; he recognized expressly the right of the peoples to free self-determination, adopted the standpoint of national autonomy, championed Polish independence, and announced the union of all the Southern Slavs of Austria by constitutional means. This programme met with a cool reception; the Poles by now were expecting a new organization from the Peace Congress; the Southern Slavs desired union with those of their race in Hungary also; the Czechs opposed the division of the administrative commission into two parts; they did not want autonomy for their nation, but incorporation of the German Bohemians in their State, and refused all negotiations.

The Emperor now made a last despairing attempt; a manifesto of Oct. 16 proposed the conversion of Austria—not of Hungary, it is true—into a federal state composed of free nations, each with the territory which it occupied. This was far from resulting in any coöperation of the nationalities in realizing their former ideal; on the contrary, they felt themselves free from all constraint, and formed Governments having no connexion with the old state. On Oct. 19 the Ukraine National Council was set up in Lemberg, and the Slovene-Croat in Agram; on Oct. 20 the Czechs followed suit in Prague, on the 21st the German delegates in Vienna, on the 25th the Magyars in Pest.

**Lammasch Ministry.**—The summoning of the last Ministry of the Austrian Empire, under Lammasch from Oct. 27-31 1918, could only be regarded as an attempt on the part of the impotent Monarch to bring about a friendly liquidation between the peoples who were separating from each other. But since the non-German nationalities were not prepared to accept such a peaceful settlement, the liquidation between the monarchy and the new republic was confined to German-Austria, and Lammasch's friendly offices might certainly be thanked for the fact that in this quarter the settlement was achieved quite bloodlessly, in favourable contrast with the two years of fighting between Czechs, Poles, Ruthenians, Magyars, Rumanians, Southern Slavs and Italians. Lammasch and his ministers shared their official premises peacefully with the new secretaries of state of the Austrian Republic, and his last official act was to send out posters with an appeal for peace and quiet. (For the later history, see AUSTRIA, REPUBLIC OF.)

<sup>1</sup> Baron Max Hussarek (b. 1860) professor of canon law at the university of Vienna, was of clerical leanings; he was Minister of Education from Nov. 3 1911 to his appointment as head of the Cabinet (July-Oct. 1918).

**BIBLIOGRAPHY.**—The *Oesterreichische Politische Chronik*, published by Neissel (Vienna 1910-8), contains among other things an account of the most important transactions of all the public bodies (Parliament, the Delegations, etc.); *Neuere Gesetzgebung Oesterreichs nach den Reichstagsverhandlungen* (Vienna); H. Kelsen, *Reichsratswahlordnung* (1907); *Hauptprobleme der Staatsrechtlehre* (1911); *Verfassungsgesetze* (1919); R. Charmatz, *Der demokratisch-nationale Bundesstaat Oesterreich* (1904); *Oesterreich als Volksstaat* (1918); *Deutsch-oesterreichische Politik* (1907); F. Kleinwächter, *Untergang der oesterreich-ungarischen Monarchie* (1920); Seton-Watson, *The Future of Austria* (1907); *The Southern Slav Question: Absolutism in Croatia*; Zd. Tobalka, *Das böhmische Volk* (1916); J. Zolger, *Staatsrechtliche Ausgleiche* (1916); P. Samassa, *Völkerstreit im Habsburgerreich* (1910); K. Reuner, *Oesterreichs Erneuerung* (1916); R. Sieger, *Oesterreichischer Staatsgedanke* (1916); C. Brochhausen, *Oesterreichische Versaltungsreform* (1916); Fr. Tezner, *Entwicklung des Parlamentarismus in Oesterreich-Ungarn* (1914); Fr. Wiesner, *Oesterreichs Ende* (1919); Th. Sosnosky, *Politik im Habsburgerreich* (1913); R. Laun, *Nationalitätsrecht* (1917); J. Bärnreiter, *Die böhmische Frage* (1910); V. Lischka, *Deutsch-Oesterreich unter slawischer Herrschaft* (1913); E. Zenker, *Nationale Organisation in Oesterreich* (1916); L. Wimmer, *Die Ostmark* (1917); Munin, *Oesterreich nach dem Kriege* (1915); W. Schilling-Singalewitsch, *Sonderstellung Galiziens* (1917); A. Skene, *Nationaler Ausgleich in Mähren* (1910); L. Czwiklinski, *Das Königreich Polen* (1917); E. Plener, *Reden* (C. Br.).

### ECONOMIC CONDITIONS

**Pre-War Period.**—During the years 1910-4, immediately preceding the World War, economic conditions in Austria showed no uniform tendency, for in many fields the signs pointed to a crisis, while in others developments seemed full of promise. These conditions were undoubtedly determined by the critical political situation from 1908 onward, which made it probable that, sooner or later, the Habsburg Monarchy would have to fight for its right to exist. It is true that nobody could have foreseen coming events; but things kept on occurring which counselled prudence, and threatened the economic situation from without. Added to this the state saw itself compelled, in view of the political situation, to increase its expenditure on armaments; and since this expenditure grew at a rate with which the revenue could not keep pace, the Government had constantly to raise large sums by borrowing in the open market, and in 1912 had even to raise a big loan in America. All this, combined with the stringency of the international money-market, meant a heavy burden on Austrian national economy. Voices were not lacking which, in view of Austria's relatively small share in foreign investments, ascribed the deterioration of the trade balance to the fact that the public bodies were "living beyond their means." (From 1875 onwards the balance of trade had been in favour of Austria; in 1907 it turned against her, and from this time the adverse balance showed a steady increase until 1913, when it slightly diminished.)

According to the census of 1910, out of 16 million persons following an occupation 8.5 millions were engaged in agriculture and forestry, 3.6 in industry, 1.6 in commerce and transport, 2.3 in the public services, liberal professions, etc. Agriculture is thus the basis of economic existence for the greater part of the population; and the favourable crop statistics for the last years preceding the war, and especially the record harvest of the year 1912, must have had a beneficial influence upon the economic situation. The production of the most important crops for the whole of Austria is shown in Table I.

TABLE I.—Crop Statistics.

(Thousands of tons.)

	1910.	1911.	1912.	1913.
Wheat . . . . .	1,539	1,574	1,861	1,594
Rye . . . . .	2,657	2,597	2,921	2,656
Barley . . . . .	1,446	1,591	1,676	1,719
Leguminous crops . . . . .	258	237	245	232

We must consider, in this connexion, that the prosperity of certain industries depends directly upon the results of the harvest. It was only in years when the harvest was most favourable that Austria-Hungary was able to provide for her own requirements in corn; for export purposes only barley was of considerable importance, while wheat, and above all, of recent years, maize had to be imported. In Table II. is shown the excess of imports of grain over exports (+), or of exports over imports (-).

**TABLE II.**  
(Thousands of tons.)

	1909.	1910.	1911.	1912.	1913.
Wheat . . . . .	+0.720	+0.278	+0.130	+0.008	+0.017
Barley . . . . .	-0.185	-0.170	-0.648	-0.196	-0.166
Maize . . . . .	+0.100	+0.036	+0.193	+0.726	+0.643
Other varieties of grain . . . . .	+0.127	+0.076	+0.216	+0.083	+0.061

In Table III. are given the average prices of the most important varieties of grain.

**TABLE III.—Average Prices, Vienna (in kronen).**

	1909.	1910.	1911.	1912.	1913.
Wheat . . . . .	15.50	12.94	12.96	12.60	12.31
Rye . . . . .	10.47	8.55	9.86	10.80	9.47
Barley . . . . .	9.83	9.02	10.32	10.67	9.19

The prices of the principal kinds of meat do not show the same tendency as those of corn; it is only after 1912 that a certain pause can be remarked in the rise of prices, as Table IV. shows:—

**TABLE IV.—Retail Price of Meat, Vienna (in kronen).**

	1909.	1910.	1911.	1912.	1913.
Beef . . . . .	177.53	177.90	195.68	207.12	217.46
Pork . . . . .	172.00	195.00	200.00	200.00	200.00
Veal . . . . .	145.00	153.00	160.00	160.00	180.00

The statistics of sugar are given in Table V.—

**TABLE V.—Sugar.**  
(Thousands of tons.)

	1909-10.	1910-1.	1911-2.	1912-3.
Raw sugar produced . . . . .	1,246	1,523	1,143	1,899
Internal consumption . . . . .	592	669	577	672
Number of workmen employed . . . . .	72,205	73,908	70,907	72,960

The price of sugar in Vienna showed in 1913 a considerable fall, following the good harvest. The total production for the year 1912-3, and also the amount of consumption, are the highest recorded in Austria.

As to the products of other industries closely related to agriculture that of beer and brandy varied, and was at times extraordinarily large.

The old Austria was very richly provided with raw materials; the coal and iron supply was especially rich; in the years immediately preceding the war the production of these two commodities followed in general a rising curve. Table VI. gives the quantities of important mineral products.

**TABLE VI.—Mineral Production.**  
(Thousands of tons.)

	1909.	1910.	1911.	1912.	1913.
Coal . . . . .	13,466	13,526	14,121	15,513	16,164
Brown coal . . . . .	25,575	24,680	24,810	25,810	36,705
Iron-stone . . . . .	2,475	2,580	2,716	2,874	2,985

The amount of manufactured iron produced was also on the increase; the quantities in thousands of tons were:—

	1909.	1910.	1911.	1912.	1913.
Refined iron . . . . .	1,193	1,218	1,305	1,447	1,458
Cast iron . . . . .	246	256	261	281	268

After 1908 the Austrian textile industry suffered from a serious depression; owing to the extraordinarily steep advance in the prices of raw materials the position of this industry was unfavourable, in spite of increased production and rising prices at the spinning mills. The figures for the cotton industry are representative:—

**Imports of Cotton.**  
(Thousands of tons.)

	1908.	1909.	1910.	1911.	1912.	1913.
187	200	183	210	234	222	

The number of cotton spindles in Austria was: in 1910, 4,643,300; in 1911, 4,563,700; in 1912, 4,797,900; in 1913, 4,909,458. After 1910 an ever-increasing quantity of cotton had to be exported.

**Exports of Cotton.**  
(Thousands of tons.)

	1908.	1909.	1910.	1911.	1912.	1913.
4.2	4.0	5.1	7.0	10.5	24.2	

The number of looms increased steadily, but the output per loom showed partially a distinct decrease.

A good general impression of the economic situation can easily be gained from the returns of the state of the labour market. Table

VII. shows how many offers of places corresponded on a yearly average to every hundred applications for work:—

**TABLE VII.—Employment per 100 Applications.**

	1911.	1912.	1913.
Smelting . . . . .	45.5	52.5	73.8
Metal-working . . . . .	64.0	68.3	45.3
Machine industry . . . . .	42.5	51.6	36.8
Wood industry . . . . .	87.2	85.7	48.3
Clothing manufacture . . . . .	95.0	94.9	74.6
Textile industry . . . . .	146.1	91.2	48.2
Paper industry . . . . .	83.6	90.1	53.4
Building trade . . . . .	80.6	85.2	61.8
Clerical occupations . . . . .	61.6	58.7	47.9

An improvement was shown only in the position of employees in smelting works, otherwise a deterioration is to be observed everywhere, most markedly in the textile industry. In spite of this wages showed a rising tendency. Table VIII. gives the average daily wage (based on the returns for the accident insurance contribution):—

**TABLE VIII.—Average Daily Wage in Vienna (in kronen).**

	1910.	1911.	1912.	1913.
Smelting . . . . .	4.10	4.22	4.27	4.41
Metal-working . . . . .	3.45	3.52	3.61	3.77
Machine industry . . . . .	4.17	4.21	4.40	4.65
Textile industry . . . . .	2.45	2.47	2.47	2.58
Wood industry . . . . .	2.79	2.94	3.00	3.13

The cost of living increased on the whole; it was only in 1913 that there was a fall in the price of certain important commodities. The average prices per kilogram of certain commodities in Lower Austria are shown in Table IX. —

**TABLE IX.—Average Food Prices (heller per kilogram).**

	1909.	1910.	1911.	1912.	1913.
Meat ( <i>Suppen fleisch</i> ) . . . . .	159.8	162.9	180.0	194.8	198.5
White flour . . . . .	46.3	39.7	39.1	38.9	38.0
Peas . . . . .	48.7	51.2	52.3	56.1	55.7
Potatoes . . . . .	10.4	11.6	14.2	14.4	12.5
Sauerkraut . . . . .	37.1	29.6	30.7	33.3	29.1
Rice . . . . .	56.5	55.5	56.9	60.1	56.3
Lard . . . . .	175.5	186.7	191.4	197.6	203.4

This very cheapening of many commodities in 1913, side by side with which went also a cheapening of many manufactured articles, was indicated as the sign of a decline in the power of consumption of the population.

It may here be mentioned that according to the savings bank returns there was also a decline in the amount of deposits. The deposits and withdrawals were respectively, in thousands of kronen:—

	1910.	1911.	1912.	1913.
Deposits . . . . .	1,706	1,860	1,950	1,872
Withdrawals . . . . .	1,610	1,790	2,149	1,970

After the heavy withdrawals of 1912 the decline in deposits; together with a continuance of heavy withdrawals in 1913, is a clear sign of economic depression. The economic situation of Austria shared in this respect in the general development of world affairs, in which also, after a period of prosperity, a reaction set in in 1913. It is only surprising that in 1912 the reaction already showed itself sharply in Austria. The year 1914 soon showed signs of a coming relaxation of the economic crisis; but this development was interrupted by the World War.

**The War Period, 1914-8.**—The outbreak of war meant the almost complete paralysis of industry in Austria. Only the very narrow range of goods manufactured in peace-time found buyers, and these were used exclusively for the equipment of those going to the front. The bulk of industry found itself faced with the impossibility of disposing of the goods previously manufactured, and acted in consequence as best suited the interests of the moment: there were general dismissals of workmen, and enterprises were restricted or suspended. Numerous industries were almost entirely dependent upon export trade (e.g. the glass and porcelain industry in Bohemia), but foreign relations were to a large extent broken off through the closing of trade-routes and the entry into the enemy camp of countries which had been important markets. Thus during the first weeks of the war there was very great unemployment in parts of the industrial regions, since the dismissals far exceeded the proportion of enrolments in the army, while agriculture, which was already occupied with the harvest, suffered from a serious shortage of labour.

The Government had not prepared in advance any measures

for setting industrial production going again in any way. Its first steps in war economy were confined to the sphere of finance and credit: the *bourse* was closed, and a moratorium announced. With regard to the latter, however, the requirements of industry were studied to a certain extent, in that the withdrawal of money from the banks was allowed, so far as it was necessary for paying wages and for the provision of working capital.

There was no revival of industry until the orders of the military authorities began to come in, which gave lucrative employment. In a short time, and without any pressure from the Government, but solely as a result of the favourable prices it offered, industrial conditions were completely transformed so as to meet the exigencies of the war. At first indeed, since the war was only expected to last a short time, there was little disposition to incur the heavy expenditure necessary in order to secure a share in the manufacture of war material; but this attitude was soon changed, and within six months factories everywhere had been adapted to the supply of munitions and all the variety of other things required by the Government for the armies. Industry was thus in many ways compensated for the paralysis of trade with private buyers in the home market and for the closing of foreign markets, and it would have been able to continue quietly on the old lines but for the emergence of a new factor which fundamentally altered the conditions. This factor was the rupture of communications with foreign countries, due in the earlier stages of the war to the limitation, and at one time the prohibition, of exports by neutral countries, the passing over of some of these countries to the enemy, and lastly the blockade by the enemy Powers, which increased in efficiency and made it more and more difficult to import the most essential commodities, until in the end it was almost impossible to obtain from abroad anything, needed either for the soldiers or the civilians.

In this respect Austria found herself in the same position as the German Empire; in fact, her position was in many respects considerably worse; many richly productive territories were temporarily occupied by the enemy; and as Austria was far less well provided with raw materials than Germany she was less in a position to produce goods for exchange. In addition to this there was another quite exceptional source of difficulties which had the most serious consequences for Austria, namely her relation with Hungary, due to the peculiar constitutional structure of the Austro-Hungarian Monarchy. The Hungarian Government could claim the right to take independent economic measures for her own territory in war-time; a joint arrangement was only possible for the territories of the Dual Monarchy—which were united for tariff purposes—by agreements between the Austrian and Hungarian Governments; and since neither Government was exclusively concerned to carry out an adjustment of economic conditions solely in accordance with what was necessary for waging war and holding out with the supplies at their disposal, but each had also to champion the interests of one half of the monarchy against the other, the negotiations between the two Governments were often attended with the greatest difficulties, and constantly ended unsatisfactorily. Hungary, in accordance with her economic situation, had always the advantage in these negotiations, since she was incomparably richer than Austria in foodstuffs, and the latter was constantly thrown back upon Hungarian supplies; and this superiority on the part of Hungary became more and more definitely pronounced in proportion as the provision of the necessities of life for the army and civil population became a steadily-increasing anxiety.

The more complete the economic isolation of the monarchy the more the lack of raw materials made itself felt, both for the manufacture of indispensable war supplies and for the feeding of the civil population. To prevent the war being brought to a premature end by dearth of supplies, the Government took measures, modelled on those adopted in Germany, for ensuring that necessary goods should be supplied to the proper quarters—whether the army authorities, manufacturers of war material, or consumers—and at a moderate price.

The quantity of raw materials which Austria had been in the habit of importing from abroad, and the quantity stored in

the country at the outbreak of the war, were comparatively very small. The Austrian and Hungarian ports were of little importance as ports of entry for raw materials, the goods stored there being mainly from the Levant. On the other hand, wool, cotton; metals, etc., which came from overseas, were imported through German or Dutch ports, and were stored there, though often already in Austrian ownership. It was of the first necessity to assure the transport through Germany of these Austrian-owned goods, and an agreement with the German Government securing this was made. Agreements were also concluded by which a share of the goods owned by Germany was conceded to Austria.

It was next necessary to organize the purchase of goods in neutral countries. This was at first left wholly to private enterprise; but, as Austrian buyers not only competed with each other but also with buyers from other countries, this was bound to send up prices, while the interests of the State were subordinated to private gain. To meet this situation Germany set up central boards (*Zentralen*), and Austria followed suit, partly at the request of the German Government, which wished to avoid the competition of Austrian agents. Since the functions of these organizations were commercial, for which the regular Government officials were unsuited, they were established as commercial joint-stock companies under peculiar conditions adapting them to the service of the state. Any dividends earned by them above 5 or 6% on their capital were to go to the State (in the first place to the Minister for War, to be applied to war purposes). In Austria the Government did not subscribe any of the capital, but the central boards were subjected to State supervision and their power of fixing prices was in many ways limited. These boards were now given the monopoly of the right to import certain wares (sometimes private buyers were allowed to purchase, but only on condition of selling the goods imported to the board); they were also entrusted with the reception of the instalments of raw materials already mentioned as released from bond in Germany. The activity of the central boards as purchasers in neutral countries did not last long; it came quickly to an end in 1915, especially after Italy's entry into the war.

Fresh tasks were, however, soon imposed upon them. The virtual stoppage of all supplies of raw materials from abroad necessitated the strictest economy in the use of those available at home, and this led to an elaborate system of Government control. Since expert advice was absolutely essential to the efficient working of such control, the task of carrying out the regulations as to the distribution of materials, etc., was entrusted to central boards under the form of war associations (*Kriegsverbände*), or economic associations (*Wirtschaftsverbände*), each controlling certain materials. The associations, to which the manufacturers using these materials had to belong, were directed by elected committees; at the head of each was an expert appointed by the Government, which was represented on the board by a commissioner exercising the Government's right of supervision. In addition to regulating the distribution of raw materials these boards exercised other useful functions, such as discovering fresh sources of supply, improving methods of production, etc. They also acted as receiving centres for goods imported from neutral countries, allied states or occupied territories. In this way there arose central boards for wool, cotton, oil and fat, hides and leather, and various metals—to name only the more important materials.

The control exercised by these boards was limited in scope and touched only comparatively narrow classes. It was otherwise with the control of foodstuffs, which was all-embracing. The problem in Austria, as elsewhere, was to keep the prices of the necessities of life at a level low enough to enable the people to live. The attempt to fix maximum prices broke down, owing to the temptations to secret-dealing, and, as in England, the card system had to be introduced.

Early in 1915 an institution was established for regulating the traffic in grain during the war (*Kriegsernte-Verkehrs-Anstalt*); it had been preceded by a central maize board, established to control the distribution of the maize contributed by Hungary.

The new institution was registered as a trader and was to be conducted on commercial principles, its expenses being covered by its receipts, and the State only guaranteeing it against eventual loss in order to secure the credit of the company. The principle of balancing expenditure and receipts was, indeed, soon abandoned, the State making advances to the institution in order that bread-stuffs might be sold under cost price. This institution, in the conduct of which officials and experts appointed by the Government took part, had complete control of all grain, flour, mills and bakeries. Its activities in fixing the price and quality of bread, etc., and in rationing, closely resembled those of the food controller in Great Britain (see FOOD SUPPLY and RATIONING).

This system of State control prevented industries which used grain as their raw material from buying in an open market, and in their case too it was found necessary to regulate supplies by means of an organization analogous to that of the economic associations already mentioned. In many cases these boards were established in connexion with the already existing trade associations (e.g. the Central Brewery Board in connexion with the Central Association of the Austrian Brewery Association), which set up their own distributing-stations and divided the raw material among producers according to a scale fixed by the Government, charging the producers a commission, in addition to the cost price, in order to cover costs. These boards also undertook other functions, such as introducing new methods of manufacture and supplying the workers in the munition factories with beer. Sugar and alcohol were also placed under the control of central boards, in connexion with existing organizations but with a certain independence: for instance, the Sugar *Kartel* ceased to exist, while the Central Sugar Board continued. The latter also managed the export of sugar, in return for which certain wares were imported.

Of particular interest were the purchasing associations formed during the war. In the autumn of 1915 the Ministry of the Interior established the "Vom Ministerium des Innern legiti-mierte Einkaufsstelle m. C. H." (Purchasing station with limited liability licensed by the Ministry of the Interior), known as the "Miles," which was charged with the buying of goods in neutral countries. At first this organization acted as agent of the newly-established *approvisionnement* departments; it was only later that it received the monopoly of the right to import certain articles, the Government at the same time placing at its disposal certain wares with which to pay for them. The prices fixed by the Miles for the sale of its wares were not at first interfered with; it was only later that its dividends were limited to 6%. It was then transformed into the "Oceg" (Oesterreichische Zentral-Einkaufsgesellschaft: Austrian-Central Purchasing Company), which was the very type of an "altruistic company." In addition to the dividend 5% was allowed for commission, office expenses and risk. By agreement with the Ministry of the Interior, as soon as the reserve exceeded by 10% the working capital (which was partly in shares, partly in bank advances) the company was to sell food under cost price; and this actually happened.

The system of regulation by central boards was severely criticised for incompetence and even for corruption, and sometimes justly; but on the whole it was amply justified by the urgent necessities of the times and by its results. Many other measures had also to be resorted to in order to maintain the industry of the country. Briefly, the duty of maintaining industries was made obligatory, and in the last resort the military authorities were empowered to take them over, though this was not likely to happen as long as the high prices continued and the Government supplied raw materials. Tillage was also made compulsory, but this had little effect on production owing to the shortage of labour, draft animals, manures and agricultural implements, together with the oppressive restrictions caused by the fixing of maximum prices.

All these measures could not alter the fact that the national economy became less and less equal to the tasks imposed upon it by the war. So soon as State control was applied to any article it could be taken as a sign that the supplies would soon come to an

end, or at any rate were very restricted; and thus it was impossible to prevent the equipment of the army from becoming gradually more inadequate, and the provision both of the army and of the population behind the lines with all kinds of necessaries from being altogether insufficient; only wholly unsatisfactory substitutes could be provided, and the available provisions could hardly be made to go round. When the war came to an end Austria was almost completely stripped of many important commodities.

No better picture can be obtained of its overwhelming economic impoverishment than by studying the figures which show the decline in the crop returns for Austria, and taking into account the fact that imports from Hungary and the territories under military occupation naturally fell far below the proportion of foodstuffs formerly imported. Table X. gives the returns of the principal crops for Lower Austria according to the statistics of the Ministry of Agriculture.

TABLE X.—Crop Statistics.  
(Thousands of tons.)

	1906-15*	1915	1916	1918
Wheat	118	80	53	54
Rye	303	212	119	133
Barley	95	74	68	47
Leguminous Crops	3	6	5	4
Potatoes	639	636	344	307

\*Average.

In the other Crown lands the crops declined in the same proportion. The production of fodder also declined steadily, the number of cattle fell, and the army horses were insufficiently fed.

To these purely economic difficulties was added the growing opposition of the population to the measures of compulsion. This in part depended on national factors, which became more clearly visible as the situation of the Central Powers became more and more unfavourable, but it was in part due simply to the exhaustion due to economic need. Thus the spirit of the labouring classes became more and more inflamed, and at the beginning of 1918 the Government had the greatest difficulty in suppressing an anti-war agitation among the working classes, which assumed a threatening form. Movements were now unchained which were bound after the end of the war to leave their impress upon the political events and internal economy of the young Austrian republic (see AUSTRIA, REPUBLIC OF). (K. P.; R. STR.)

*Finance and Banking.*—The third licence granted to the Austro-Hungarian Bank expired on Dec. 31 1910. It was at first extended provisionally, as it was impossible to reach a settlement between Austria and Hungary regarding the continuance of common currency and banking arrangements. In Hungary a strong majority, which the Government could not afford to ignore, insisted on the formation of an independent Hungarian bank; on the other hand the advantages accruing to Hungary through the community of the financial and banking organization were quite obvious. There was an important divergence of opinion between Austria and Hungary concerning the constitution of the bank. Since the closing years of the 19th century the Austro-Hungarian Bank had pursued a policy which had in the main the object of making the Austrian *krona* a gold exchange standard. It was decided, however, by the Austrian financial authorities that the obligation of the Austro-Hungarian Bank to convert its notes into gold on demand should remain suspended as hitherto, owing to fear lest the renewal of the obligation of the bank to cash its notes in gold should lead to a rise in the rate of interest. Hungary, on the other hand, striving for access to the money markets of the West, desired that the obligation of the Austro-Hungarian Bank to cash its notes should be explicitly mentioned in the law, in order to make the public loans rank as easily negotiable securities on foreign *bourses*. In the banking law of Aug. 8 1911 a compromise was formed on the following lines. The suspension of cash payment by the Austro-Hungarian Bank was continued, but the bank was bound to provide, by every means at its disposal, that the value of its notes as quoted on foreign *bourses* should be permanently secured in proportion to the parity of the legal mint standard of the *krona* currency. Hungary's wishes were met by the introduction of a specially prompt procedure for the eventual future abolition of the suspension of the bank's obligation to cash its notes. By the same law, besides other less important provisions, the amount of the bank's tax-free issue of notes was raised from 400 to 600 millions of *kronen*, and the conditions formerly attached to the issue of 10 and 20 *kronen* notes were sensibly relaxed.



A 4% bank-rate had been uninterruptedly in force from May 8 1908 to Oct. 23 1910. From Oct. 24 1910 to Feb. 3 1911 it was 5%; on Feb. 4 1911 it was reduced to 4½%, and on Feb. 23 1911 further to 4%. From Sept. 22 1911 to Oct. 25 1912 the bank-rate was again 5%; on Oct. 25 1912 it was increased to 5½%; and on Nov. 16 1912 a rate of 6% came into force and so remained until Nov. 27 1913, when it was lowered to 5½% falling on Jan. 20 1914 to 5%, on Feb. 3 1914 to 4½%, and finally on March 12 1914 to 4%.

These changes in the bank-rate show that Austria passed through a financial crisis and credit difficulties in 1912-3, from the consequences of which she had only just recovered at the outbreak of the war. The stringency of the money market and the crisis had their commencement as early as the spring of 1912. The Balkan War, which broke out in the autumn of 1912, did not occasion the crisis, but it made it more acute. The number of trade insolvencies in Austria-Hungary had reached its height in 1912. The Vienna Creditors' Association for the protection of claims in bankruptcies had in 1909-11 fresh failures with liabilities of 45, 40 and 43 millions of *kronen* respectively. In 1912 the value of fresh claims involved rose to 112 millions of *kronen*; in 1913 it still amounted to 73 millions. One obvious sign of a crisis was the demand for loans against security from the Austro-Hungarian Bank, which was the result of the unfavourable position of investments on the *bourse*. In each of the five years, ending Dec. 31, from 1909 to 1913 the loans granted by the Austro-Hungarian Bank against securities amounted to 90, 149, 187, 355 and 311 millions of *kronen* successively. The bank-note circulation rose in proportion. Notwithstanding the fact that the banking law raised the tax-free note issue in 1911 from 400 to 600 millions of *kronen*, in 1913 the bank was unable to avoid incurring tax payments for notes issued in excess of the amount allowed free of tax, a state of affairs which had no parallel in the bank's history. From Aug. 23 1912 to Jan. 23 1914 the bank return showed no tax-free reserve of notes.

On July 23 1914 the gold reserve of the Austro-Hungarian Bank amounted to 1,238 millions of *kronen*, its silver to 201 millions. In its portfolio were discounted bills to the amount of 768 millions of *kronen*. It had loans on security outstanding to the amount of 186 millions, and the bank-notes in circulation amounted to 2,130 millions of *kronen*.

The outbreak of the World War compelled the bank to raise its rate on July 27 1914 from 4 to 5%, on July 31 to 6% and on Aug. 2 to 8%. The public rushed to the bank to obtain advances by pledging securities. On Aug. 4 1914 the Bank Act was suspended by imperial ordinance having the force of law. In this manner the bank was converted into an institution which could supply the Government, by fresh issues of notes, with loans to an unlimited extent. The legal forms under which this source of credit was assured were various, but the actual result was in every case the same. The bank-rate was reduced to 6% as early as Aug. 20 1914, and the granting of credit on depositing securities was facilitated by extending the limits of the securities accepted.

The note issue was as follows:—

Dec. 31 1914	5,137 millions of <i>kronen</i>
" " 1915	7,162 " " "
" " 1916	10,889 " " "
" " 1917	18,440 " " "
" " 1918	35,589 " " "

In proportion to the increase of the notes in circulation prices and wages rose, and the *krona* depreciated on the foreign exchanges. The Government tried to oppose the rise in prices by penal measures, and in public attributed the rise of foreign rates to speculation. A Central Securities Board (*Devisenzentrale*) was set up on Feb. 24 1916; and regulations were issued on Dec. 19 1916 and June 18 1918, attaching a series of conditions to dealings in foreign money, bills and securities, which amounted actually to a monopolizing of all such operations by the *Devisenzentrale*. These measures had no success. The value of the American dollar, in terms of Austro-Hungarian paper *kronen* with legally fixed value, varied in fact, as shown by the Swiss exchange market, as follows:—

End of Aug. 1914	5.12
" " Dec. 1914	5.76
" " " 1915	7.85
" " " 1916	9.56
" " " 1917	8.40
" " Oct. 1918	11.83
" " Dec. 1918	15.77

*State Finances.*—The revenue from taxation rose year by year, partly owing to the increased profits of industry, partly to fresh increases in taxation. From the year 1902 to the financial year 1914-5 the State revenues doubled, rising from 1,730 millions of *kronen* to 3,460 millions of *kronen*, but this increase in revenue could only be achieved by placing an extraordinary strain on the taxable capacity of the country. In the financial year 1913 the amount of estimated expenditure rose to 3,461 millions of *kronen*. Of the estimated net revenue of 2,102 millions of *kronen*, 432 millions (20.5%) came under the head of receipts from direct taxation, 905 millions (43%) under the head of receipts from indirect taxation and taxes on commerce, while 294 millions (14%) were the proceeds of State property and

State institutions. Of the direct taxes the land tax produced 39 millions, the house taxes 127 millions, the taxes on industry 127 millions and the income tax 102 millions. Of the taxes on consumption the spirit tax produced 95 millions, the beer duty 85 millions, and the sugar duty 176 millions. The State debt amounted to 11,340 millions of *kronen*. On the outbreak of the war it was at first impossible to contemplate meeting the cost of the war by raising existing taxes or by imposing fresh taxation. The costs of the war were in the first place met by loans and the assistance of the note-printing press. The means of carrying on the war were obtained by the State becoming the debtor of the Austro-Hungarian Bank, in so far as concerns the war.

The debt of the Austrian State to the Austro-Hungarian Bank in direct loans made by the bank to the State amounted at the end of 1919 to 25,088 millions of *kronen*. But, besides this, the bank had also afforded credits to the State in other forms. In return for bonds given by the Austrian and Hungarian State they issued Treasury bills, and transferred the proceeds from them to the two finance departments. The total amount of such Treasury bills in circulation at the end of 1918 was roughly 7,400 millions of *kronen*.

The Post Office Savings Bank was also made to serve the financial needs of the State. Whenever a war loan was impending it accepted advances from the members of the Banking Consortium, which had to place the war loans, and as soon as the subscription was closed they were compensated for the underwriting. At the end of June 1919 these advances still amounted to 2,605 millions of *kronen*.

Foreign credit also was laid under contribution by the Austrian State. On Oct. 31 1918 the amounts of outstanding debts incurred abroad during the war were as follows:—

2,696 millions of German Reichsmarks
42.9 " " Dutch florins
20.6 " " Danish kroner
7.9 " " Swedish kroner
3.6 " " Bulgarian levas.

The home money market was approached by the Government through the issue of war loans. The total number of such war loans was eight. They bore interest at 5½%. The first issue took place on Nov. 1 1914, and from that time onwards a fresh war loan was issued about every six months. In this way a State debt of 35,069 millions of *kronen* was accumulated.

Up to Sept. 1915 no increases in taxation were introduced in Austria, except a slight increase in the duty on beer; neither were any new taxes created. Even the reform of taxation carried out in the autumn of 1915 (modification of the inheritance and donations duty and the taxation on insurance policies and legal charges) cannot be regarded strictly as war taxes, as they had been planned a considerable time before the outbreak of the war and had only been delayed by the inability of Parliament to continue its work. It was not until 1916 that increases took place in every field of taxation. The price of tobacco and the tariff of the State railways were considerably increased, special war increases were introduced in the direct taxes, and in April 1916 an entirely new tax was imposed—the "war profits tax," the name of which was subsequently altered to "war tax." But all these taxes and increases of taxation were quite inadequate to meet the enormous expense of conducting the war. War finance was not able to dispense with the printing of notes. (L. V. M.)

#### ART AND LITERATURE, 1910-21

*Art.*—All the Austrian artists who had been most characteristic of the age of Francis Joseph died about the year 1890. They had built a new Vienna and transformed the large provincial towns. The keynote of their style might be described as Austrian imperial sentiment. This common quality was also true of the decadent period of this style, which reached its height in 1890; and even after the World War it still had its representatives. Notable in this class were, among architects, Karl König (1841-1915); among sculptors, Karl Kundemann (1838-1919) and Kasper Zumbusch (1830-1915) in Vienna, and Josef Myslbek (b. 1848) in Prague; among painters the Czech Brožík (1851-1899), the Pole Jan Matejko (1838-1893), and the Viennese portrait-painters L. Horowitz (1843-1917) and Heinrich von Angeli (b. 1840). Others, such as the painter Adalbert Hynais (b. 1854) of Prague, and the Viennese sculptor Edward Hellmer (b. 1850), or the Viennese engraver Ferdinand Schmutzer (b. 1870), displayed symptoms of a transitional style, dominated by an international influence. Austrian artists now sought every kind of contact abroad; many studied and lived in Munich, Berlin and Paris. As examples may be cited the Czech painters Antonín Slavček (1870-1910) and Max Svabinsky (b. 1873), the Pole Jacek Malczewski (b. 1855), and the artists who in 1897 founded the Viennese Independents (*Wiener Secession*). Evidence of their success in bringing new life to a dead tradition was given by the painter Rudolf Alt (1812-1905), who in

spite of his great age brought about a transformation, and the architect Otto Wagner (1841-1918), who, though his roots were set in the age of Francis Joseph, became the leader of the moderns in Vienna.

Side by side with these artists, who, in spite of their international features, devoted their talents to Austria, were others who split away from their native land and became completely identified with foreign art, for example: Alphons Mucha (b. 1860), who became a French decorative artist; the painters Charles Schuch (1876-1903) and Emil Orlik (b. 1870); the sculptors Hugo Lederer (b. 1871) and Hans Metsner (1870-1919); and the architect Josef Olbrich (1867-1908), who has all more importance in the development of German art in general than of Austrian art.

Meanwhile there arose various national schools, which developed with energy their racial peculiarities. The young Poles, united in the society called the *Słowka*, endeavoured to depict Slav gaiety in a riot of gaudy colour (Chelmonski, Melchior, etc.); in like manner the Slovak Joza Uprka (b. 1862) exploited his native land, his materials being peasant customs and types and the peasant's love of colour. Frantisek Bilek (b. 1872) mirrored in mighty contours the ardent faith of the Slav peoples, while Jan Stursa, endowed with equal power, refined it into an art of truly European quality. In contrast with these two Czech sculptors may be placed the highly gifted Southern Slav Mestrovic, who expressed in his art the refractory energy and wild fanaticism of his race. Among German-Austrian artists the originality of the Tirolese Albin Egger-Lienz (b. 1868) deserves special mention, for in it the Tirolese element plays an important part.

In Vienna the leading personality of his generation was Gustav Klimt (1862-1918); his very delicate decorative art, his subtle taste in colour, his inclination towards industrial art, make his painting so Viennese that it would hardly be comprehensible in other surroundings. A pendant to him is the architect Josef Hoffmann (b. 1869), who originated in the school of Otto Wagner, whose stiff principles he softened, however, by his richer taste (e.g. the Stoeliet House in Brussels); the tendency towards decorative and industrial art which Klimt had revived in Vienna was turned into a systematic school by Hoffmann. In theatrical decoration, in domestic architecture, in all branches of the handicrafts, Vienna became a leading centre of the moderns, the "Viennese Workshops" (*Wiener Werkstätte*) and the "Austrian Craft Guild" (*Osterreichische Werkbund*) being the centre of their activity. A leading figure among the younger generation of artists, after the war, was Oskar Kocoshka (b. 1888). (H. Tk.)

*Literature and Drama.*—Between 1910 and 1920 new tendencies and personalities came into the literary foreground in Austria, and moreover death made many gaps in the ranks of the leading representatives of the older traditions. In 1916 died Marie von Ebner-Eschenbach (see 8.843\*). Born in the same year as Francis Joseph (1830), she had continued her literary activity to the very end of her life. In 1915 she published the sketches entitled *Stille Welt*, and from her literary remains appeared in 1916 *Erinnerungen an Grillparzer* and *Blätter aus einem zillosen Tagebuch*: prose poems, satirical attacks on Ibsen, Hauptmann and the modern school, for whom she had no sympathy. Her enthusiasm for Tolstoy was correspondingly great, and among her successors she marked out for special praise Enrica Handel Mazzetti, with whom she carried on a correspondence which was published under the title of *Der Dichterinnen stiller Garten*. In 1918 died the Styrian dialect poet Peter Rosegger (see 23.734). He too delighted in creation till the end of his life, and was occupied in revising his collected works for an edition in 40 volumes. *Rückblicke auf den Schauplatz des Lebens: Abenddämmerung* appeared posthumously in 1919; it deals with questions of time and eternity, religious, social and political problems, and the characters of eminent people, e.g. Schiller and Francis Joseph. His greatest successor as a dialect poet he held to be the Tirolese dramatist Karl Schönherr. During the decade several other notable writers died. Count Albrecht Wickenburg (1838-1912),

husband of the poetess Almay-Wickenburg, was a fine lyrical poet who made a masterly translation of Shelley's *Prometheus*. Freiherr Alfred von Benger (1853-1912), important as an essayist and playwright, founded the Deutsches Schauspielhaus at Hamburg, and ultimately became director of the Burgtheater. Max Burckhard (1857-1912), a distinguished jurist, who was director of the Burgtheater for eight years, was a champion of Ibsen, Hauptmann, Schnitzler and Anzengruber, and patron of the greatest actors of the rising generation—Hedwig Bleibtreu, Lotte Medelsky, Mitterwurzer and Kainz; he was active as a critic, dramatist and story-teller, but the artistic merit of his work was unequal. In 1917 died Bertha von Suttner, authoress of the novel *Die Waffen nieder!*, well known as a protagonist of the League of Peace, and winner of the Nobel prize. The Zionist Hugo Zuckermann (1881-1917), whose song, *Drüben am Wiesenrand sitzen zwei Dohlen*, was much sung at the beginning of the World War, fell in battle. Peter Altenberg (1859-1910) died at the age of 60; he was equally original in his life and his art, and his books, *Wie ich es sehe*, *Was der Tag bringt*, *Semmering*, etc., have a highly personal touch.

In spite of these losses there was no lack of talent in Austrian literature, for many followed in the footsteps of their predecessors but most of them sought and found ways of their own. The creations of Ibsen, Zola, Maeterlinck, Dostoevsky, Tolstoy, Shaw and Strindberg had their influence on the younger generation. Modern and ultra-modern tendencies, the new romanticism, symbolism, occultism, expressionism, took the place of realism, naturalism and impressionism. The partisans of Stirner and Nietzsche, the *Sturm und Drang* school, lost all sense of reason and moderation. Far removed from these wandering fires, and yet receptive to the subtle innovations of Ibsen and Hauptmann, there developed the most powerful of contemporary German-Austrian writers, Karl Schönherr. Born in 1830 at Axams near Innsbruck, the son of a schoolmaster, he spent his life in Tirol, going to the university of Vienna, where he qualified as a doctor. In 1895 he first appeared to the public in his dialect poems, *Innhalter Schnitzler*, and his sketches *Allerhand Kreuzköpfl'*. His drama, *Judas von Tirol*, was an unsuccessful attempt to represent the betrayer of Andreas Hofer on the stage. *Die Bildschnitzer* and *Sonnwendtag* met with success both at the Volkstheater and the Burgtheater. In 1907 followed the tragic-comedy *Erde*, in which the principal rôle, that of the old peasant Grutz, was splendidly played by Josef Kainz, and is a finely conceived type. The character was so convincing that the original of old Grutz was looked for in every walk of life and mistakenly supposed to be Francis Joseph, since he kept the impatient heir, Francis Ferdinand, waiting in vain for the throne. After a fairy play, *Das Königreich*, Schönherr composed his tragedy, *Glaube und Heimal*, a national-historical drama which gave a vivid picture of the Reformation and Counter-Reformation and the proscription of Protestants in the Alpine regions, and in spite of ultramontane agitation was played hundreds of times with the greatest success. In 1915 Schönherr completed his technically unique drama for three characters only, *Der Weibsteufler*; it was violently attacked by ecclesiastical fanatics, and its morality was defended by the poet in an indignant answer to the bishop of Munich. In the middle of the war Schönherr published the drama on the subject of Hofer which he had begun in 1909, *Volks in Not*, a German heroic poem, which represented so impartially the light and dark sides of the Tirol's struggle for freedom that the military censorship of Berlin and Vienna, on trifling pretexts, for years prevented this masterpiece from being produced. Schönherr's remaining plays are: *Fruchtbarkeit*, the tragedy of a childless peasant woman; the *Kindertragödie*, again for three characters only; and two pessimistic pictures of academic life, *Narrenspiel des Lebens* (1918) and *Der Kampf; ein Drama geistiger Arbeiter* (1920). Schönherr's stories, *Caritas* (1907) and *Aus meinem Merkbuch* (1911), are worthy to rank with his plays, and in its sober form, grim humour and tragic reticence bear the true impress of the Tirolese race.

Fundamentally different in method and art is the most notable Austrian dramatist next to Schönherr, Arthur Schnitzler.

\* These figures indicate the volume and page number of the previous article.

Schönherr in his substance and method everywhere proclaims himself of the Alps; Schnitzler always shows himself a citizen of the Viennese capital and a man of the world. Schönherr is a moralist, Schnitzler a sceptic. Whether in jest or in earnest, both as a writer of short stories and verse drama, he is principally preoccupied with the love motive; *Anadol*, a set of dialogues representing the world of pleasure and inspired by an exuberant wit recalling Maupassant, was followed in 1895 by his best youthful production, *Liebelel*, and by a series of plays which discuss in sophisticated dialectic the problems of love and marriage. In *Litteratur der Böhme* and *Comtesse Mizi* he attacks with exuberance and wit the highest Austrian aristocracy. In the grotesque *Der grüne Kakadu* he shows an avenging doom ready to break forth boldly over the unconscious ancient régime from a low drinking-den, on the day of the storming of the Bastille. The historical piece, *Der junge Medardus*, has its scene laid during Napoleon's stay at Schönbrunn; it is a picture of the times, in which he does not fail to include the episode of Napoleon kicking his hat. *Professor Bernhardt* is a satirical picture, drawn by a master hand, of Austrian university and parliamentary life; it was played hundreds of times in Berlin, but under the Habsburg Monarchy it was forbidden by the censor owing to its only too true reflection of insignificant ministers and party leaders; it was not till the republic that the ban was removed from this comedy. As a story-teller Schnitzler achieved uncommon success when most happily inspired (*Leutnant Gustl*, 1901; *Masken und Wunder*, 1912). His novel, *Der Weg ins Freie* (1908), has the Jewish question as its subject.

The Jewish problem was also treated, with far deeper penetration, by Schnitzler's friend, Richard Beer-Hofmann, who had been silent since the appearance of his *Gruf von Charolais* half a generation earlier, in his Biblical drama *Jahob's Traum*, which both in its form and contents is of lasting value. Another close friend of Schnitzler, Hugo von Hofmannsthal, the much-fêted leader of the aesthetic school of lyrical poets, wrote the libretto for Richard Strauss's *Elektra*, *Der Rosenkavalier* (1911), *Joseph, Ariadne auf Naxos* (1912), *Die Frau ohne Schatten* and so shared in the world-wide fame of the musician. He gave a new version of *Alkestis* and of the mediæval drama *Everyman* (*Jedermann*). Widely read in the literature of the world, he formulates his opinions in refined though sometimes over-elaborate prose: the earlier collections of shorter works were supplemented after the war by several volumes of *Rodauner Nachträge*. The former protagonist of this group, Hermann Bahr, suffered from an excess of versatility. The theatrical success of his much-acted *Concert* (1909) was not repeated in the case of any of his later pieces. In his *Erinnerung an Burckhard* (1913), *Aufsätze für Religion und Philosophie*, *Inventur*, *Expressionismus* (1917), and the many volumes of his *Tagebuch* he aimed at being an index to all the vicissitudes in art and life. He sprang from one extreme to another; once a follower of Marx, a free-thinker and an anarchist, after the World War he was for the moment preaching reaction in science and uncompromising Catholicism. Hans Müller (b. 1882) is a writer of verse drama whose downright methods hit the taste of the masses. His drama *Könige* (1915), which enjoyed the special patronage of the German emperor and dealt ostensibly with the feud between Louis of Bavaria and Frederick of Austria, but in reality with the rivalry of the Hohenzollerns and Habsburgs, had an enormous popular success. He modelled himself on Sudermann in one piece, *Der Schöpfer*, the hero of which is the self-confident inventor of a serum; a weaker effect was produced by his play *Sterne*, which explains Galileo's retraction as due to timidity. On the other hand his *Flamme* (1920-1), which represents on the stage the life of the *demi-monde*, ran for months in the great theatres of Berlin and Vienna, in spite of all the objections of the critics.

Austrian achievements in lyrical poetry were no less noteworthy than in the drama. According to the testimony of the German Soergel, the young lyric poets of the time venerated above all others two poets, Dehmel, the poet of will, and Rainer Maria Rilke (b. 1875), the poet of mood. They regard Rilke's bewitching melodies, his delicacy of observation, his mystic

ardour, his absorption in God, as the highest revelation of their kind. Rilke himself, in his autobiographically-coloured *Aufzeichnungen des Malin Laurids Brigge* (1910), thus defines his poetic mission: "Verses are not sensations, as people think—they are experiences. For the sake of a single verse one must see many towns, men and things, one must know the animals, one must feel how the birds fly and in what wise the little flowers open in the morning."

Regardless of Rilke, Stefan George, or Hofmannsthal, the singers of the older generation continued to write lyrics in the traditional form: for example, the Styrian pastor Ottokar Kernstock (b. 1878), canon of Vorau, *Aus dem Zwingergrülein*, and with Rosegger, *Steirischer Waffensengen* (1915), *Schwertlilien aus dem Zwingergrülein*, *Kriegsgedichte*. In Tirol too there was an ecclesiastic, Brother William (Müller), who wrote patriotic songs during the World War. Arthur von Wallpach (b. 1866) and Franz Karl Ginzkey (b. 1871) also preserved their old skill. A new note was struck both in war and peace by Anton Wildgans (b. 1881), who put forth, in quick succession to his first work, *Herbstfrühling* (1909) and his self-revealing *Sonette an Ead* (1913), *Infanterie*, *Milag*, and several dramas with a lyric quality, *Armut*, *Liebe*, and *Das Irac*, which led to his appointment as director of the Burgtheater.

The greatest talent among the younger poets was Franz Werfel (b. 1890), who in his version of the *Trojan Women* of Euripides (1917) vividly painted the curse of war, and afterwards, like Albert Ehrenstein (b. 1886), openly confessed himself a violent opponent of militarism. But the most outspoken condemnation of the war party, military or civil, was pronounced by Karl Jeremias Kraus (b. 1874), editor of the review *Die Fackel*, a very considerable satirist and an unshrinking adversary of social abuses in his books, *Sittlichkeit und Criminalität* (1909), *Die chinesische Mauer* (1910), *Pro domo et mundo* (1912), *Kultur und Presse* (1915). In 1919 he displayed, as in a mighty fresco, "the last days of humanity" (*Die letzten Tage der Menschheit*), a series of scenes arising during the World War, which, changing from wild mockery to awful tragedy, pictures the atrocities and misdeeds of army commanders and diplomats, the credulity of the masses, the barbarity of military justice, the brainlessness and heartlessness of those in high places. Exaggerated in some details, and on the whole over-severe to his native land, *Die letzten Tage der Menschheit* is none the less, in spite of all reservations, a considerable literary achievement, a picture of the times having the value of a document.

Among the older generation of Austrian novelists we may mention Emilie Mataja (Emil Marriot, b. 1855) for descriptions of ecclesiastical and social life; Adam Müller-Guttenbrunn (b. 1852) for novels dealing with life in the Banat; and Stüber Gutthér (b. 1872), the successor of Pötzl and Chlavacci among Viennese humorists. Among the most remarkable artistically are Enrica Handel Mazzetti (b. 1871) and Rudolf Hans Bartsch (b. 1873). Baroness Handel, who had been given a strictly religious education by the "englische Fräulein" at Sankt Pölten, gave in her principal works—*Meinrad Helmpergers denkwürdiges Jahr* (1900), *Jesse und Marie* (1906), *Die arme Margaret* (1910), *Stephans Schwerdtner* (1913), *Ein deutscher Held* (1920)—propagandist stories in which free-thinkers, Protestants and blasphemers are led by their tragic experiences to become Catholics. The action takes place sometimes in the 18th century, sometimes at the time of the Counter-Reformation, and in *Ein Deutscher Held* in the days of the Archduke Charles. Capacity for drawing convincing historical pictures here goes hand-in-hand with the gift of dramatic intensity. Her Catholic ideas do not make the authorless unjust to heretics, but she has a fatal taste for spiritual and physical torture, and wallows in scenes of blood and torment. Bartsch, originally an officer, won his first success with *Zwölf aus der Steiermark*, which was followed by many others, the greatest of which was *Schwammel*, a novel about Franz Schubert. More closely knit in his technique is Jakob Wassermann, born at Fürth in 1873, a precision in form and a virtuoso in language; and richer in ideas is Erwin Guido Kolbenheyer (b. 1878), notably in his novel about Spinoza and Paracelsus.

Up to the end of the World War the Vienna Burgtheater had still the ambition of ranking with the Comédie Française as the first theatre of the continent of Europe. The dialect drama, to which Raimund, Nestroy and Anzengruber had contributed, still had the reputation of being, as Platen said, a popular form of comedy which is more comic than the whole of the German theatre. In the meantime the Burgtheater lost its brilliant *Jöyses* Bernhard Baumeister (1828-1917), and its greatest master of declamation, the famous emotional actor, Josef Kalns (1858-1918). Finally Alexander Girardi (1850-1918) died too, the popular Viennese comedian, whose gift for music and improvisation showed him an unworthy representative of the Italian tradition.

See Albert Soergel, *Dichtung und Dichter der Zeit* (1916); Oscar F. Walzel, *Die deutsche Dichtung seit Goethes Tod* (1919); Alfred Maderno, *Die deutsch-österreichische Dichtung der Gegenwart* (1920). (A. B.)

*History.*—During 1910-20 the influence of the work of Theodor von Sickinge (1826-1908), and of the Austrian Institute for Historical Research, which had been brought by him to a high pitch of excellence, was shown in a marked activity on the part of Austrian historical writers. In the footsteps of Sickinge, and also of his great contemporary Julius von Ficker (1826-1902), came their disciples Engelbert Mühlbacher (1853-1903) and Emil von Otenthal (b. 1855); Oswald Redlich (b. 1858), with his *Rudolf von Habsburg*; Alfons Dopsch (b. 1868), with his *Wirtschaftliche Entwicklung der Karolingerzeit* (2 vols., 1912-3) and *Wirtschaftliche und soziale Grundlagen der europäischen Kultur-entwicklung* (2 vols., 1918-9); Ludo Moritz Hartmann (b. 1865) with his *Geschichte Italiens*, etc.

A number of the historians who came from the school of Sickinge turned to modern history, under the influence of Ottokar Lorenz (1832-1903). Distinguished among them by his gift for vivid exposition was Heinrich Friedjung (1851-1920), notable for his *Der Kampf um die Vorkerrschaft in Deutschland* (2 vols., 11th ed. 1919), *Oesterreich, 1848-1860* (2 vols., 4th ed. uncompleted), *Das Zeitalter des Imperialismus, 1884-1914* (vol. i., 1919), *Gesammelte Aufsätze* (1919). A rich literary activity was displayed by August Fournier (1850-1920), whose biography of *Napoleon* (3rd ed., 1913, Eng. trans. 2nd ed. 1911) became widely known even beyond the sphere of the German-speaking public. From the pen of A. F. Pribram there appeared, among other works, the second volume of *Die englisch-österreichischen Staatsverträge* (1913), and *Die geheimen politischen Staatsverträge Oesterreich-Ungarns 1879-1917* (1920; English trans. by A. C. Coolidge, 1920).

Worthy of note among the younger historians trained at the Institute were Hans Uebersberger (b. 1877), with *Russlands Orientpolitik in den letzten Jahrhunderten* (vol. i., 1913); H. R. von Srbik (b. 1878), with *Wallenstein's Ende* (1920); Wilhelm Bauer (b. 1877), with *Die öffentliche Meinung auf historischer Grundlage* (1917); Viktor Bibl (b. 1870), with *Der Tod des Don Carlos* (1919); H. Kretschmayer (b. 1870), with his *Geschichte Venedigs* (2nd vol. 1920). The methodical research into texts inaugurated in Austria by Sickinge and Ficker produced valuable fruits in the sphere of German and Austrian legal and constitutional history. Prominent among the workers in this field were Arnold Luschnin von Ebengreuth (b. 1841); H. von Voltelius (b. 1862) and Siegmund Adler (1813-1920).

Among historians unconnected with the above-mentioned movement, Josef Freiherr von Helfert (1820-1910) was distinguished by a rare devotion to work; a man of great talents, he crowned his life-work by a history in two volumes of the Austrian Revolution of 1848. Ludwig von Pastor (b. 1854) continued his widely read *Geschichte der Päpste* (5th vol., 1920); Eugen Guglia (1855-1918) published a book on *Maria Theresia* (2 vols., 1917). In the sphere of Slavonic history the unfinished *Geschichte Serbiens* of J. Jirecek (1857-1918) is also worthy of note. As an economic historian Karl Grünberg (b. 1801) established his reputation during the decade.

The eminent Viennese professor of constitutional law, Josef Redlich (b. 1869), widely known abroad through his masterly

works on English local government and English parliamentary procedure, published in 1920 the first volume of *Das oesterreichische Staats- und Reichsproblem*, a history of the internal policy of the Habsburg Monarchy from 1848 to the break-up of the empire. This first volume brings the account down to 1867.

(A. F. Pr.)

#### FOREIGN POLICY, 1909-18<sup>1</sup>

Austro-Hungarian foreign policy in the crucial decade which, through the World War, led to the downfall of the empire, can only be understood by recalling the main historical problem that confronted the old monarchy.

Since the foundation of the German Empire and the kingdom of united Italy an extension of Austria-Hungary towards the S. and W. of Europe had become impossible. Only in the S.E. could she still count on an expansion of her territory and power. Thus from the seventies of the 19th century onwards the policy of the leading Austro-Hungarian statesmen had taken the direction indicated by geographical conditions. In this Austria had to reckon with the opposition of Russia, which, with the pressing back of Turkish influence, had become her great rival in S.E. Europe. In order to maintain herself as a Great Power, make her frontier secure against hostile attacks, and suffer no restriction on her further development, she could not allow another Great Power to command the Danube and its mouths, and arrogate to itself the hegemony of the Balkan peoples. This political and economic opposition between the Habsburg Monarchy and Russia was reinforced by opposition of an ethnical and cultural nature. In view of this struggle against a competitor far superior in population and military strength, Austrian statesmen had sought an alliance or understanding with those European states whose interests appeared to run parallel with their own. It was to the benevolent attitude of Germany and England that Austria had owed the occupation of Bosnia and Herzegovina and the right of maintaining garrisons in the Sanjak of Novibazar—the door to the Near East and the first step towards an expansion of Austria-Hungary's sphere of influence in the Balkans, which promised rich prospects, but at the same time an increase in Russian hostility.

From the early eighties of the 19th century Andrássy's successors did indeed try to arrive at a *modus vivendi* with Russia, and were zealously seconded in this effort by Prince Bismarck, who wished to hold the balance between his two allies. Numerous crises were successfully overcome, but the conflict of interest remained, and was especially heightened after the Russo-Japanese War (1904-5) had ended unfavourably for Russia. Russian statesmen renounced the policy, which they had followed for a time, of getting to the "warm ocean" in the Far East, and returned to the one which had been followed by Peter the Great and Catherine and never entirely given up, the goal of which had been the conquest of Constantinople and the command of the Dardanelles. The constantly increasing differences between Germany and the Western Powers, and the advances made by the latter towards friendship with the court of the Tsar, led in 1907-8 to a close entente between Russia and England, and hence to the development of the long-standing alliance between Russia and France into a Triple Entente.

Baron Aehrenthal, who from the autumn of 1906 had directed the foreign policy of the Habsburg Monarchy, recognized the threatening danger, which became greater and greater as the internal affairs of the Turkish Empire assumed a more and more critical aspect. This empire he wished to preserve, if it could by any means be done; but in the event of its final liquidation he was firmly determined to safeguard the interests of Austria-Hungary. It was above all necessary to make sure of the possession of the occupied prov-

<sup>1</sup> The article under EUROPE, written from a British historian's point of view, should be read for a somewhat different perspective of the European situation which resulted in the World War. See also SERBIA. The account given here naturally reflects, in various aspects, the point of view of an Austrian historian.—(Ed. E. B.)

inces of Bosnia and Herzegovina, which had been under Austro-Hungarian government for 30 years past. The Young Turk Revolution, in July 1908, served as a pretext for carrying into effect the annexation of these territories, which had been planned long since. It happened opportunely that at this very time Russian statesmen wished to effect the realization of their designs on the Dardanelles. Isvolsky, who directed Russian foreign policy, knew indeed that it would not be easy to win over Great Britain to his plan. But since he believed himself sure of French support, he hoped to achieve at least his immediate aim, the opening of the straits to Russian ships-of-war, so soon as he had come to an understanding with the Central Powers, and especially with Austria-Hungary. During the negotiations entered upon, on Aehrenthal's initiative, between the Cabinets of Vienna and St. Petersburg, Isvolsky expressed his consent to the annexation of Bosnia and Herzegovina in the event of the Vienna Government's falling in with his plans as to the straits question. Aehrenthal seized upon this proposal, for he hoped that the annexation of these provinces would enable him to take active measures in face of the Greater Serbia movement.

At the beginning of July 1908 Isvolsky handed in at Vienna a memorandum which guaranteed to the Habsburg Monarchy, besides Bosnia and Herzegovina, the greater part of the Sanjak of Novibazar as well. Aehrenthal accepted Isvolsky's offer in so far as it applied to the annexation of Bosnia and Herzegovina; but he demanded the same right for the warships of Rumania and Bulgaria as for those of Russia, and in addition a guarantee against an attack on Constantinople by a Russian fleet entering the Bosphorus. In return he was ready to give up the Sanjak and the rights appertaining to Austria-Hungary in Montenegro, and therefore the plan of an advance on Salonika, the seizure of which Andrássy had had in view as the next objective in Austria-Hungary's policy of expansion in S.E. Europe. On Sept. 15 Aehrenthal met Isvolsky at the château of Buchlau in Moravia, informed him of the impending Austrian annexation of Bosnia and Herzegovina, and promised him in return a free hand in his proceedings with regard to the question of the Dardanelles. The two ministers promised each other mutual support; Aehrenthal renounced the Sanjak of Novibazar, as a set-off for which Isvolsky gave a promise that Russia would not take possession of Constantinople. A European conference was to give its sanction to their settlement. A binding written agreement was contemplated, but was not arrived at on this occasion.

When, however, at the beginning of Oct. 1908 Francis Joseph publicly announced the annexation of Bosnia and Herzegovina as a *fait accompli*, a storm of indignation burst forth in many quarters. It was insisted, especially in England, that agreements settled by international treaties could only be modified with the agreement of all the contracting Powers. Both in Paris and in London, where Isvolsky had betaken himself in order to obtain the consent of the Western Powers to the measures which he had concerted with Aehrenthal, he met with a decided refusal. Disappointed in his expectations, he now declared that he had been led astray by Aehrenthal.

Serbia lodged a protest against the annexation of Bosnia and Herzegovina, demanded autonomy for these territories under the guarantee of the Great Powers, and a port on the Adriatic for Serbia, with a strip of territory to connect it with Serbia. Since Austria-Hungary showed no inclination to take these demands into consideration, Serbia now began to strengthen her military forces. At the same time a violent anti-Austrian movement began to make itself felt in Turkey. All goods coming from Austria-Hungary were boycotted, and Austro-Hungarian traders living in Turkey were subjected to annoyance. Bulgaria, whose prince, Ferdinand of Coburg, had assumed the royal crown on Oct. 5, 1908, also took sides against Austria-Hungary. Aehrenthal had made himself personally offensive to that country, which now entered into negotiations with Russia and Serbia. In Italy, too, a hostile tendency towards Austria gained the upper hand. Victor Emanuel III. described the annexation of Bosnia and Herzegovina as a stab at the Treaty of Berlin, and Tittoni, who had

spoken on Oct. 7 in terms favourable to the annexation, declared in his great speech in the Consulta at the beginning of Dec. 1908—in contradiction with the tenor of a letter which he had addressed to Aehrenthal on Oct. 4—that he had entered into no engagements with regard to it. The nationalist press and the irredentists fanned the flames, and in the Austrian Parliament the Slavs, and above all the Czech leaders, raised loud complaints.

But Aehrenthal remained firm. He was convinced that Russia, which had not yet recovered from the defeat which she had suffered in the Russo-Japanese War, would not draw the sword, and that he would therefore succeed in achieving his ends without bloodshed. His own efforts were directed towards the preservation of peace. In this point of view he was at odds with a powerful party, led by Conrad von Hötzendorff, chief of the Austro-Hungarian general staff, which was in favour of a decision by force of arms. In order to meet Russia's views Aehrenthal expressed his consent to the convening of a European conference, but insisted at the same time that he could only promise Serbia and Montenegro economic compensations, and made it a condition that the question of Austria-Hungary's sovereignty over Bosnia and Herzegovina should not be discussed at the conference, but only taken cognizance of by it. Aehrenthal's attitude aroused violent indignation in London and Paris. But since Germany resolutely took its stand on the side of the Habsburg Monarchy, France, with an eye to her Moroccan interests, only gave a lukewarm support to the Russian demands; and Isvolsky found himself compelled to beat a retreat. As early as Dec. 1908 he agreed that the conference should recognize the annexation of Bosnia and Herzegovina after a previous discussion of the matter had taken place between the several Cabinets. Meanwhile Sir Edward Grey, the English Secretary of State for Foreign Affairs, advised the Turkish Government to give their consent to the annexation of Bosnia and Herzegovina to be bought by a proportionate cash indemnity. Aehrenthal fell in with a suggestion in these terms, and on Feb. 26 1909 concluded an agreement with Turkey which secured to the Sultan, in return for his recognition of the annexation of Bosnia and Herzegovina by Austria-Hungary, a considerable sum of money in compensation for Ottoman State property in the annexed provinces. In the course of the month of March the negotiations as to the form of consent to the annexation to be given by the Great Powers concerned were brought to a conclusion. It was to be effected by official declarations on their part, a European conference being avoided. On March 24 declarations in this sense were handed in at Berlin and Vienna by the Russian Government; those of England followed on March 28.

The danger of an Austro-Serbian war, which for some time had appeared inevitable, had fortunately passed by. Even after the settlement of the Austro-Turkish conflict the Serbs remained stubborn; Aehrenthal, however, wanted to avoid war, and now, as before, hoped to reach his goal by calm firmness and conciliation. At the beginning of March 1909 he declared that Serbia, in order to avoid the humiliation of having her fate settled by the statesmen of Vienna, might submit to the decision of the Great Powers. But the Serbian Government declined, and continued to arm. The Cabinet of Vienna then decreed that the troops in the S.E. of the Monarchy should be reinforced. Isvolsky now saw that Francis Joseph was in earnest. Since he could not venture on war, he accepted the proposal of the German Imperial Chancellor, Bülow, that Russia herself should use her influence over Serbia in the direction of moderation. On Great Britain's initiative negotiations were entered upon with the Government of Vienna, which led to the drafting of a note which should secure to Austria-Hungary the satisfaction which she demanded.

After overcoming great difficulties it was possible to effect an agreement. On March 31 the Serbian Government handed in a note at Vienna in which it declared that Serbia had not suffered any injury to her rights through the annexation of Bosnia and Herzegovina by Austria-Hungary, and promised to change the attitude which she had hitherto taken towards the Habsburg Monarchy, to maintain

Effect on the International Situation.

Stubborn Attitude of Serbia.

Submission of Serbia.

good neighbourly relations with the monarchy, and to reduce her army to the footing of the previous year (1908). In so doing Serbia submitted to the behest of the signatory Powers, but at the same time to the will of Austria-Hungary. Montenegro thereupon followed suit. The event was a victory for Aehrenthal, but a pyrrhic victory, in that through it was effected the cleavage of Europe into two hostile camps. Russia now broke definitely with Austria-Hungary and became increasingly hostile to German policy, while England recognized with increasing clearness the significance of the Southern Slavs in the struggle against Germany, and especially of Serbia as a battering-ram against Germany's ally, the Habsburg Monarchy.

Two other events led to a further strengthening of the Triple Entente. One was the *rapprochement* between Russia and Italy, made manifest by Nicholas II.'s visit to Racconigi (Oct. 24 1909); the other was the secret treaty concluded in Dec. 1909 between Russia and Bulgaria, which ranged the latter in the Russian sphere of influence, and contained among other things the declaration that the realization of the ideals of the Slav peoples in the Balkan peninsula would only be possible after a favourable outcome of Russia's contest with Germany and Austria-Hungary.

Yet at this time these opposing tendencies did not come out into the open. The Central Powers sought rather to overcome them. At the beginning of the year 1910 negotiations took place with Russia which were intended to further the establishment of better relations. After hopeful preliminaries they split on the irreconcilability of their conflicting interests. Aehrenthal's efforts at Rome seemed to meet with more success. He was able at the end of 1909 to arrive at an agreement with the Italian statesmen on the Albanian question, by which further friction between the two states, who were rivals in this quarter, should be avoided. In subsequent conversations which he held on frequent occasions in 1910 with the Italian Foreign Minister, San Giuliano, measures were considered which should smooth the way towards the establishment of friendly relations between the Cabinets of Vienna and Rome.

In the years 1910 and 1911, moreover, Aehrenthal was eagerly striving to do everything for the maintenance of peace. He endeavoured to reconcile the differences which were forever cropping up anew between England and Germany. In order to win over Rumania and conciliate Serbia, commercial treaties were concluded with them. In the interest of peace, too, he placed no obstacle in the way of the assumption of the royal style by the Prince of Montenegro (Aug. 29 1910). Yet Aehrenthal kept his aim steadfastly in view: namely, the upholding of Austria-Hungary's interests in the Near East; and he left the Balkan peoples in no doubt that he would not be a peaceful spectator of the downfall of Turkey. He was in a difficult position when, in the autumn of 1911, Italy seized the opportunity for taking possession of Tripoli. A strong party, headed by the chief of the general staff, Conrad von Hötzendorf, held that the moment had arrived for coming to a reckoning with their faithless ally. In any case they wanted to use this favourable opportunity for assuring to Austria-Hungary the hegemony of the Balkans. But Aehrenthal, supported by Francis Joseph, stood up for the maintenance of the Triple Alliance. He even held that it was in the interest of the Habsburg Monarchy that Italy's imperialistic aspirations should find satisfaction on the south of the Mediterranean. He therefore asked Italy, in leaving her a free hand in Tripoli, not to interfere with the designs of the Vienna Cabinet in the Balkan peninsula. Also he requested the withdrawal of the Italian fleet from the coast of Albania, and protested against Italian designs on Salonika.

The fact that Aehrenthal gained his ends by these demands confirmed him in the idea that he had hit upon the right way, and increased his hopes of being able to guard Austria-Hungary's interests in this difficult crisis without resorting to arms. Aehrenthal's death (Feb. 17 1912) was therefore a heavy loss to the Habsburg Monarchy, which made itself all the more felt since just at that time new dangers were arising for it in S.E. Europe. His successor as

*Triple Entente Re-  
strengthened.*

*Aehrenthal's  
Efforts for  
Peace.*

*Aehrenthal's  
Crisis Sur-  
rounded by  
Berchtold.*

Austro-Hungarian foreign minister was Count Leopold Berchtold, who had formerly been ambassador at St. Petersburg.

The Italo-Turkish War, and especially the closing of the Dardanelles at the instance of the Turks, had done severe harm to Russian trade, and increased the desire of Russian statesmen to gain command of the Black Sea. It was widely held, too, that this was a favourable opportunity to bring about a Balkan alliance under Russian leadership, which should make it possible for Russia, as protector of the Slav peoples of the Balkans, to take possession of Constantinople. Hartwig, the Russian minister in Belgrade, was particularly active in this direction. Other circles, led by Charykov, the Russian ambassador in Constantinople, thought it possible to attain the same end by other means. They wanted to preserve Turkey, but to make her Russia's vassal. She was to be admitted to the Balkan alliance and, in return, to allow the Russian fleet a free exit to the Mediterranean. But Charykov's efforts failed. Turkey refused; and in March 1912 Charykov had to leave Constantinople. The old plan of forming a Balkan alliance against Turkey was now taken up again. The greatest difficulty in its way was the jealousy between the Bulgarians, on the one hand, and the Serbs and Greeks on the other. Bulgaria would not hear of conceding to these peoples the extensions of territory which they claimed in Macedonia. It was not till March 1912, when the Russophil Gueshoff-Danef Cabinet came into power in Sofia, that the Serbo-Bulgarian treaty was concluded, which was indeed aimed in the first place against Turkey, but also had the Habsburg Monarchy in view. Two military conventions (of May 12 and July 12 1912) further developed this Serbo-Bulgarian alliance. Bulgaria now undertook, in case Austria-Hungary occupied the Sanjak of Novi-Bazar, to contribute 250,000 men towards a war with this Power. On May 29 Ferdinand of Bulgaria concluded a treaty with Greece against Turkey. But at the same time he handed in peaceful declarations at Vienna, Berlin and Constantinople, and let himself be fêted in Vienna as a friend of the Habsburg Monarchy.

At the beginning of July 1912 the Tsar Nicholas II., at his meeting with the German Emperor at Baltiaki Port (Port Baltic), in Esthonia, laid stress upon his pacific intentions. But as early as Aug. there began the long-prepared conflict of the Christian peoples of the Balkans with Turkey, leading to bloody local struggles, in which there was no lack of atrocities on either side. In vain did the Central Powers endeavour to bring about an intervention of the Great Powers of Europe. On Sept. 30 1912 the order for mobilization was issued in Sofia, Belgrade and Athens. In order to have her hands free in this direction, Turkey thereupon determined to bring to an end the war against Italy by sacrificing Tripoli and Cyrenaica, and on Oct. 18 1912 the treaty of peace was signed at Lausanne. In the meantime the Balkan States had completed the last preparations for war. On Oct. 8 Montenegro declared war on Turkey, and soon after, on Oct. 17 and 18, Serbia, Bulgaria and Greece did likewise. To the astonishment of the European Great Powers they gained decisive victories over their opponent from the outset. The battle of Kirk Kilisse (Oct. 22) went in favour of the Bulgars, that of Kumanovo (Oct. 26) in favour of the Serbs. The Turkish troops, falling back rapidly, did indeed defend themselves successfully on the Chatalja lines against the oncoming Bulgarians, and thereby saved their threatened capital. But since none of the Great Powers would take active measures in their favour, they could not hope to reconquer the lost provinces. On Dec. 3 1912 an armistice was concluded between Turkey and Serbia, and between Turkey and Bulgaria. Greece took no part in it, but continued the struggle.

The success of the Balkan States against Turkey meant a marked weakening of the prestige of Austria-Hungary in the Balkans. The entry of the Greeks into Salonika (Nov. 8 1912) and the advance of the Serbian troops to the Adriatic produced a particularly painful impression in Vienna. But consideration for the Slav peoples of the monarchy, who hailed with joy the victory of the Christian states of the Balkans over Turkey, and the dread of

*The  
Balkan  
League.*

*Balkan  
War.*

*Berchtold's  
Balkan  
Policy.*



incurring the open enmity of Russia by an energetic intervention on behalf of the Sultan, held the Vienna Government back and disposed it, as early as the end of Oct. 1912, to modify its demands. Albania was to be allowed to develop freely; Serbian aspirations towards the Adriatic were to be rejected, and Rumania's claims to an extension of territory to be considered. Berchtold demanded no more than security for Austro-Hungarian economic interests in the Balkans. On this account he refused in the most decided terms to consent to the proposal of the French Government that Austria-Hungary, like all the other Great Powers, should express her *désintéressement* in the events taking place in the Balkan peninsula.

In so far as his plans concerned Albania and Serbia, Berchtold found Italian politicians in favour of them, since they saw in the spread of the Slav peoples to the Adriatic a danger to Italy, to oppose which in good time seemed to them more important than any further check to the influence of the Habsburg Monarchy, divided as this was against itself. The common danger brought about a *rapprochement* between the two Cabinets, which was considerably strengthened by Italy's annoyance at the attitude of France at the time of the Libyan War. Thus it happened that as far back as Dec. 5 1912, in spite of violent opposition on the part of the nationalist deputies, of the more important section of the press, and of Italian public opinion, the Triple Alliance was renewed once more for another six to twelve years, the period being reckoned from 1914 onwards.

But the moderation displayed by Austria-Hungary in her Balkan policy did not produce the effect which had been hoped for at the Ballplatz. It weakened rather her credit in the Balkans, disappointed the few partisans she had there, and encouraged the hopes of her many opponents. Paying no attention to Berchtold's declarations, the Serbs continued their efforts to extend their power to the Adriatic. On Nov. 10 1912 Serbian troops reached Alessio. At the same time Serbian politicians laboured to incite the other Balkan peoples against Austria-Hungary, since it was only at her expense they could hope to find compensation for the concessions which they had made in the March treaty with Bulgaria. In St. Petersburg, too, they left no stone unturned to create opinion against Austria-Hungary. And, in fact, in Nov. 1912 the Russian Cabinet declared itself in favour of the cession of an Adriatic port to Serbia, and was supported in this by France and England. The Russian trial mobilization increased the danger of a bloody collision. The Vienna Government on its side proceeded to prepare for war. The fact that Conrad von Hötzendorf was again entrusted with the position of chief of the general staff, which he had had to give up a year before because he had spoken in favour of an active military policy, showed that the war party had increased its influence at the Court of Vienna.

But the disinclination of the three emperors to conjure up a world war for the sake of Albania or Serbia, together with the influence of Great Britain, proved stronger than the urgency of the war parties either in Vienna or St. Petersburg. In opposition to Austria-Hungary, Bethmann Hollweg, the German imperial chancellor, and Kiderlen-Wächter, the German foreign minister, energetically upheld the point of view that a compromise with Russia was both desirable and possible. And in a like sense William II., when the Archduke Francis Ferdinand tried to convince him at Springe (Nov. 23 1912) of the necessity of an energetic course of action against the demands of the Serbs, insisted that, while he was in favour of using firm language, he was anxious to see all steps avoided which might lead to a rupture with Russia. In order that no doubt should arise as to the policy of the German Empire, Bethmann Hollweg, in announcing in the German Reichstag (at the beginning of Dec. 1912) the successful renewal of the Triple Alliance, added the remark that Germany must leave it to her Austrian ally to realize her aspirations alone, and would only join in a conflict in the case of a war of aggression against her, for the preservation of her own position in Europe and the defence of her own future and security.

Under the impression of these declarations Berchtold at the end of 1912 rejected Conrad's propositions, which aimed at the occupation of the Sanjak of Novibazar and ridding Albania of Serbian troops, and he sought rather to serve the interests of the monarchy by diplomacy. In this connexion it stood him in good stead that a change had meanwhile come over affairs at the Court of St. Petersburg, not uninfluenced by external factors, and especially by England. The peace party had gained the upper hand. As late as Nov. 1912 the Russian Government made a communication at Belgrade to the effect that it would offer no active opposition to the formation of an autonomous Albania, and requesting an attitude of reserve towards Austria-Hungary on the part of the Serbian Cabinet. Shortly afterwards, on the suggestion of Sir Edward Grey, a conference of ambassadors in London was decided upon, to take place at the same time as the peace negotiations which were being carried on there between Turkey and her opponents, with a view to finding a solution of the outstanding questions at issue between Russia and Austria-Hungary. After long hesitation Berchtold, under pressure from Germany and Italy, consented to the conference of ambassadors, but insisted that as a matter of principle Austria-Hungary should take no part in any discussion of the question as to whether Serbia should be permanently established on the Adriatic. Serbia thereupon declared her willingness to yield to the decision of the Great Powers. Yet the Austro-Hungarian and Russian troops remained under arms, and Serbian intrigues still went on. The negotiations of the London conference of ambassadors proceeded slowly. When the peace conference, which was sitting at the same time, came temporarily to an end on Jan. 7 1913, owing to Turkey's refusal of the demand of the Balkan States that she should cede the three fortresses of Adrianople, Scutari and Janina, which had not yet fallen, the conference of ambassadors presided over by Sir Edward Grey made efforts to prevent a resumption of hostilities; but these attempts were unsuccessful. On Feb. 3 1913 began the second Balkan War.

Meanwhile the deliberations dragged on in London as to the frontier of the new Albanian state which was to be set up. Russia in this matter presented the views of Serbia and Montenegro, but met with resolute opposition not only from the representatives of Austria-Hungary but also from those of Italy. And it looked as if it would come to an armed conflict between Austria-Hungary and Russia. But at the last moment the danger was averted. Prince Gottfried zu Hohenlohe was sent on a special mission to St. Petersburg and succeeded in convincing Nicholas II. of Francis Joseph's pacific intentions. The negotiations now opened led in March to the cancelling of the mobilization on the frontiers which had been set on foot by both Powers. At the same time the Russian representative at the London conference of ambassadors announced his sovereign's readiness to consent to the allotment of Scutari to Albania in the event of Austria-Hungary's acceding to the separation of Diakova, Ipek (Pet) and Prisca from Albania. On March 20 the representative of Austria-Hungary handed in a declaration in the same sense.

By now the war between the Balkan States and Turkey had taken its course, leading, in spite of the unexpectedly gallant defence of the Turks, to the fall of Janina (March 6) and Adrianople (March 26). On account of the wrangling which broke out between Bulgaria on the one hand, and Serbia and Greece on the other, as to the partition of Macedonia, on April 16 1913 Ferdinand of Bulgaria concluded an armistice with Turkey. But there was no sign of the peace which was desired on all sides. Serbia, in defiance of the protests of the Vienna Cabinet, continued to occupy Northern Albania with Durazzo, and Montenegro continued to besiege Scutari, although the London conference of ambassadors had assigned it to the Albanian state; and the Great Powers decided on a naval demonstration against Montenegro, which was not, however, intended seriously by all the participants. The war party at Vienna, led by Conrad, wished to force the Montenegrins to raise the siege, if necessary by arms,

but did not win their point. On April 23 Scutari fell into the hands of the Montenegrins. It was not till then that Berchtold nerved himself to the declaration that the Habsburg Monarchy would not tolerate such an insult, and made the necessary preparations for armed intervention. Montenegro thereupon submitted to the dictates of the Great Powers. On May 5 the Montenegrin troops evacuated Scutari and on the next day the Serbs left Durazzo. At the end of May peace preliminaries were concluded between the Turks and their opponents. But it was impossible to arrive at an agreement between the victors as to the division of the territory which had fallen to them.

Notwithstanding the fact that it had had its way so far as Albania was concerned, the prestige of the Vienna Government

*Austria-Hungary and Rumania.* in the Balkans had seriously diminished in the course of the two wars, not only in the eyes of the victorious peoples, whose self-confidence had mightily increased, but also in the eyes of its Balkan ally Rumania. King

Charles had wanted to join in from the beginning of the first Balkan War, in order to prevent a hegemony of Bulgaria in the Balkans, and had only allowed himself to be persuaded to renew for the fifth time his alliance with the Powers of the Triple Alliance by an engagement from the Central Powers that they would see to it that Rumania received a corresponding extension of territory in the S.E. (Silistria and the surrounding territory was what they had in view). He now strongly pressed the Court of Vienna for the fulfilment of this engagement. Berchtold did in fact make every effort to decide the Bulgarian Government in favour of suitable concessions to Rumania. But when his efforts broke down, those circles in Bucharest which favoured the Triple Entente (France, Russia, England) managed to make King Charles acquiesce in invoking Russia's mediation in order to acquire the desired increase of territory. But Russia's success at Sofia did not satisfy the Rumanians, and induced them to join hands with Ferdinand of Bulgaria's enemies. This was an advantage for Austria-Hungary, which was, however, set off by the increasing influence of the Entente Powers and their party in Rumania.

Austria-Hungary's leading statesmen met with no better success in their efforts to establish permanently friendly relations with Italy. San Giuliano's desire for common

*Strained Relations with Italy.* action with the Habsburg Monarchy in the Adriatic question had indeed led recently to a *rapprochement*

between the two Cabinets. In the course of 1913 German statesmen had also succeeded in persuading Italy to further military commitments and to the conclusion of a naval convention, the object of which was defined as "the attainment of naval supremacy in the Mediterranean by the defeat of the enemy fleets" in a war against the Western Powers. But the voice of the Italian press and of nationalist circles, who demanded more and more insistently the dissolution of the Triple Alliance and union with the Triple Entente, did not leave the Central Powers any confidence in Italy's loyalty to her engagements. Meanwhile the third Balkan War had broken out. Serbia and Greece, joined by Rumania and Turkey, advanced against Bulgaria. The latter, left in the lurch by Russia and only supported diplomatically by Austria-Hungary, succumbed, and by the Peace of Bucharest (Aug. 10 1913) Bulgaria found herself compelled to enter into an agreement with her enemies by which she was a serious loser.

The outcome of these three wars meant for the Austro-Hungarian Monarchy a notable loss of prestige in the Balkan

*Effect of the Balkan Wars.* peninsula. Her adversaries in this quarter, Serbia and Montenegro, and especially the former, had achieved a considerable extension of their possessions, and henceforth, being no longer separated by the Sanjak of Novibazar, were in a position to join forces against the Habsburg Monarchy when the right moment came. The Bulgarians, however, disappointed in their hopes, ascribed the humiliating defeat which they had suffered in the third Balkan War to the feeble attitude of the Vienna Cabinet, which had indeed taken the first steps in the direction of active participation in the war in favour of Bulgaria, but had then, out of fear of

Russia and under German and Italian pressure, contented itself with a fruitless diplomatic intervention. The fact that Berchtold's efforts to obtain a revision of the Peace of Bucharest in favour of Bulgaria met with no result could not contribute towards strengthening Austria-Hungary's credit at Sofia. On the other hand, the line of action of the Vienna Government, which in its own interest was working incessantly for a compromise between Bulgaria and Rumania, but could satisfy neither of these two Powers, led to a clearly perceptible estrangement between the Courts of Vienna and Bucharest, which enabled the Rumanian friends of the Triple Entente to win from the King his acquiescence in paving the way to better relations with the Western Powers and Russia. The only advantage which balanced these heavy losses of power and prestige for Austria-Hungary was the dissolution of the Balkan League, the revival of which was prevented by the inextinguishable hatred between Serbs and Bulgarians, a fact of all the greater importance for the Vienna Government as its relations with Serbia became more and more strained and the probability of an armed conflict increased.

The London conference of ambassadors had, on July 29 1913, come to an agreement as to a fundamental law for Albania, and at its final sitting on Aug. 11 had settled the southern frontier of Albania, long a subject of controversy. *Resistance of Serbia.* Serbia alone declined to give up the Albanian territories which she had already occupied in defiance of the London decrees, and persisted in her resistance when the Vienna Government pressed for their evacuation. The growing differences between the Triple Alliance and the Triple Entente meant that no united action could be expected from the European Great Powers. Italy and Germany—the latter more on grounds of prestige, the former because her interests in this case ran parallel with those of Austria-Hungary—associated themselves with the Vienna Government when, on Oct. 15 1913, it again insisted at Belgrade on the execution of the London decrees. Serbia at first again refused; but when Berchtold showed that he was in earnest and on Oct. 19 demanded at Belgrade, under threat of force, the evacuation of the Albanian territory occupied by Serbia, the Serbians submitted to the dictates of the Vienna Government (Oct. 20 1913) in accordance with advice from the Triple Entente. The Serbian press, however, continued to create prejudice against the policy of the Balplatz, and the Serbian Government used every opportunity of encouraging movements which had as their object the winning over of the Southern Slavs living under the Government of the Habsburg Monarchy to the idea of a Greater Serbia.

In Rumania, too, the agitation against Austria-Hungary made headway every month. The agitation in Bucharest in favour of the Hungarian Rumanians became more and more *Doubtful Alliance of Rumania.* active, and their liberation from the domination of the Magyars was indicated as a desirable and possible object of Rumanian policy. In order to achieve it a *rapprochement* was advocated between Rumania and Russia, and a suitable pretext was found in Nicholas II.'s very cordially expressed congratulations on King Charles's successes in the last Balkan War. It is true that the visit of the Rumanian heir to St. Petersburg (March 27 1914) did not bring about that open passing-over of Rumania into the camp of the Triple Entente which Russia had hoped for. King Charles could not be brought to this point, and the Rumanian Government, too, did not at that moment want to break definitely with the Central Powers. But the speeches accompanying the exchange of toasts at the meeting of Nicholas II. with Charles at Constantza on June 14 1914 left no possible doubt that the friends of the Triple Entente had gained the upper hand at Bucharest. As early as this, Count Ottokar Czernin, the representative of Austria-Hungary at Bucharest, expressed the decided opinion that, in the event of a war between the Central Powers and the Triple Entente, King Charles would not fulfil his pledges. At the same time he uttered a warning against underrating the danger of an encirclement of the Dual Monarchy through the formation of a new Balkan League under the patronage of Russia and France.

To hinder this encirclement now became the principal endeavour of Viennese statesmen, who were untiringly at work trying to compose the outstanding differences between Bulgaria on the one hand and Turkey and Rumania on the other, and if possible also to win over Greece to a closer adhesion to the Central Powers. But all their efforts broke down owing to the divergent interests and the mutual distrust of the Balkan States, which came clearly to view during the negotiations conducted under the mediation of the Central Powers during the winter of 1913-4. The Turko-Bulgarian Treaty, which was nearly concluded in May 1914, did not come to anything; still less did the compromise between Rumania and Bulgaria, which had been furthered with such especial zeal on the part of Vienna. And the *rapprochement* of Greece with the Triple Alliance, desired by Emperor William, could not be realized, since the claims of the Greeks met with insuperable opposition both in Sofia and in Constantinople.

Not the least of the factors contributing to these unsatisfactory results was the difference of opinion in influential circles in Vienna and Berlin as to the value of the various Balkan States in case of an international conflict. Emperor William was a resolute opponent of King Ferdinand of Bulgaria, whom he did not trust; on the other hand, he was firmly convinced that in case of war Charles of Rumania would be true to his engagements as an ally. On this account he endeavoured to persuade the Vienna Government to bring Rumania over entirely into the camp of the Triple Alliance, even at the cost of sacrifices and of the danger that Bulgaria might join the opponents of the Central Powers. But Berchtold was afraid that the Bulgarians, left in the lurch by Austria-Hungary, might come to terms with Serbia, Greece and Rumania, and in company with them and with Russia fall upon the Habsburg Monarchy. Hence he held fast to his policy, which saw in the maintenance and exacerbation of the differences existing between Bulgaria and the other Balkan States the only means of preventing the formation of an alliance of all the Balkan peoples against the monarchy. The conflicting points of view of leading statesmen in Vienna and Berlin led to very lively debates, and threatened seriously to impair the good understanding between the two Governments. However, Berchtold gradually succeeded in bringing round the Emperor William and the German statesmen to his views. From March 1914 onwards it was determined that the union of Bulgaria with the Central Powers must remain the main object of their policy, and that agreements with the rest of the Balkan States must only be entered into in so far as they should not be in conflict with the just desires of Bulgaria.

The removal of this discord was hailed with all the more joy by the Vienna Cabinet since its relations with Italy were getting more and more strained. San Giuliano, it is true, maintained a correct demeanour towards the Vienna Government and worked for a compromise in the ever-recurring conflicts to which the divergent interests of the two states in the Balkans gave rise. It was even possible, in the discussions which took place between him and Berchtold at Abbazia in April 1914, to arrive at an agreement as to the policy of Austria-Hungary and Italy in the Balkan question, based upon the maintenance of the autonomy of the Albanian state, which had been set up in the meantime and for the government of which Prince William of Wied had been designated. But the attitude of the press and of the deputies with nationalist sympathies, not to speak of the Italian representatives in Albania, made it apparent that influential circles beyond the Alps were endeavouring to frustrate San Giuliano's policy.

In the eyes of leading Viennese statesmen the sympathy for the Triple Entente which was displayed by the Italians with ever-increasing frankness was all the more ominous since they saw that France, Russia and England were taking steps to increase their own military strength, and also had information of the negotiations which were being conducted by all three Governments with those of Spain, Italy and the Balkan States, which were believed to have as

their object the isolation of the Central Powers. At that time, however, the outbreak of a world war was not held to be imminent in Vienna, for it was known that negotiations were going on between Berlin and London aiming at the establishment of better relations. Count Mensdorff, the Austro-Hungarian ambassador at the Court of St. James, did his utmost to further these efforts. But conditions in the Balkans pressed for a decision. In Vienna it was believed that France and Russia had been successful in their efforts to bring into existence a Balkan League which should also include Turkey, and which would have threatened the existence of the monarchy.

On June 22 1914, before the assassination of the heir to the throne of Austria-Hungary, Conrad von Hötzen-dorff, as chief of the general staff, drew up a memorandum in which he described the existing conditions in the Balkans as intolerable, and insisted on the necessity for using clear language at Bucharest. The Rumanian Government must be forced, he said, to declare openly whether it would make common cause with the Central Powers or not. In the latter case an attempt must be made to decide Bulgaria, by far-reaching promises, to bring to a conclusion the negotiations for an alliance which had been going on for a considerable time. These views of Conrad's were shared not only in military circles but also by Austrian statesmen of authority. In a memorandum intended for the German Government, which was also drawn up before the murder of Francis Ferdinand, Count Berchtold<sup>1</sup> emphasized the urgency of making every effort to form a Balkan League, under the leadership of the Central Powers, which should include Bulgaria, Rumania, Greece and Turkey, and have as its objective the suppression of Serbia as a political power in the Balkans.

Before this document was dispatched to Berlin the news arrived in Vienna that Francis Ferdinand, with his consort, Sophie, Duchess of Hohenberg, *née* Countess Chotek, had been murdered in Sarajevo. It confirmed the already settled conviction in this quarter of the necessity for coming to a reckoning with Serbia. On July 5 the Vienna *mémoire* was handed to the German Emperor by Councillor of Legation Count Alexander Hoyos (b. 1876), who had been sent on a special mission to Berlin, in the presence of the Austro-Hungarian ambassador, Count Ladislaus Szögyeny-March (1841-1916), and on the following day to the imperial chancellor, Bethmann Hollweg. Authoritative circles in Berlin adopted the views of the Vienna Government, and gave it to understand that it might reckon on Germany's aid even in case international differences were to arise from the Austro-Serbian conflict.

It was in reliance upon these promises, which were repeated in the most emphatic way by the German ambassador at the Court of Vienna, Tschirsky-Bögendorff, that Berchtold, at the sitting of the council of ministers on July 7 1914, gave utterance to the opinion that they would be forced at last to a military reckoning with Serbia. His point of view met with general agreement; nevertheless Count Stephen Tisza, the Hungarian prime minister, who had already on July 1st expressed his dissent and the reasons for it in a memorandum presented to Emperor Francis Joseph, desired not only the opening of diplomatic negotiations but also the formulating of demands possible of fulfilment. His first point he carried, but in the second he failed. The council of ministers decided to adopt the course of diplomatic negotiations, but at the same time to lay down conditions the rejection of which would be inevitable. In that case the Serbian question would have to be solved by the power of the sword. Tisza, ill content with this conclusion, reiterated his dissentient

<sup>1</sup>The basis of this document is to be found in a *mémoire* drawn up by the envoy extraordinary and minister plenipotentiary, Baron Ludwig Plotow (b. 1867). It was later amplified by Rudolf Pogatscher (b. 1859), who occupied the same position and was particularly well informed as to the Balkan question. From the middle of June onwards it was revised by Baron Franz Matschenko (b. 1876), of the Austro-Hungarian Foreign Office, and finally by Count Berchtold.

views in a second memorandum of July 8 and counselled moderation, laying stress on the danger of international complications. This view would have been reinforced by the report drawn up by Friedrich von Wiesner (b. 1871), who had been sent by the Vienna Ballplatz to Sarajevo, on the circumstances in which the murderous attack on the heir to the throne had taken place. This report established the fact that no direct connexion could be proved between the murderer and the Serbian Government. But this report failed of its effect. Authoritative circles in Vienna remained under the conviction that the Court and Government of Belgrade had for long lent their benevolent support to the Greater Serbian movement, and held to their determination of putting an end to an unbearable situation. The dangers which might arise from drastic measures were indeed weighed; the possibility of a world war was even considered. But the opinion predominated that all must be staked on one card. "Better an end by fear than fear without end," ("*Lieber ein Ende mit Schrecken, als ein Schrecken ohne Ende*") was the *sés* of a leading statesman. These circles were confirmed in their resolve to appeal to arms by the pronouncements of Conrad von Hötzendorf, who, in reply to a question, summed up his judgment in the following sense: that the military prospects of the Central Powers in a world war (Great Britain's intervention on the side of the enemy not being yet reckoned with seriously) were no longer so favourable as in previous years, but were certainly more favourable than they would be in the near future. That decided it. On July 14 the decision was adopted of sending Serbia an ultimatum with a short time-limit. Tisza, after long vacillation, acquiesced, but with the condition that Austria-Hungary was to make a solemn declaration that—with the exception of necessary minor rectifications of the frontier—she sought no territorial gains at the expense of Serbia. By this means Tisza hoped to placate Russia and to deprive the Italians of any pretext for advancing any claim to compensations under Article VII. of the Treaty of the Triple Alliance. This request of Tisza's was indeed taken into account at the conference of ministers of July 19, but on the same occasion Berchtold declared that Serbia was to be made smaller and the provinces taken from her were to be divided among some of the other Balkan States.

The note to Serbia, which had not found its final form till after repeated modification of its language,<sup>1</sup> was read out, and the time for its presentation to the Serbian Government appointed for the afternoon of July 23.

Its essential points ran as follows:—Since the Greater Serbian movement directed against Austria-Hungary has been proceeded with in recent years with the ultimate object of separating from the Habsburg Monarchy certain of its parts; and since the Serbian Government, in contradiction with the declarations handed in by it on March 31 1909, has not only done nothing towards its suppression, but has rather encouraged it, the Austro-Hungarian Government must formulate certain demands in order to put an end to this state of affairs. In these demands are included, amongst others, the condemnation of agitation having as its object the breaking away of portions of the monarchy and the admonition of the peoples against a continuance of this course: both to be accomplished through an announcement in the official press organ and through an army order on the part of the king; the suppression of the Greater Serbian agitation on Serbian soil; the dissolution of societies working for this object; the dismissal of the officials and teachers compromised; the participation of representatives of the Imperial and Royal Government in the measures which the Serbian Government should be under the obligation to undertake with a view to the suppression of the Greater Serbian movement.

The presentation of the note took place at the appointed time; on July 24 the world was informed of its contents. Only Germany approved unreservedly the *démarche* of the Vienna Government; the remaining Powers raised objections. Sazonov, the Russian foreign minister, broke into a violent outburst against Austria-Hungary, and declared it to be a matter of international concern. Sir E. Grey described the note as "the

most formidable document" that one State had ever addressed to another. Negotiations began at once between the groups of Powers. They aimed at the extension of the time-limit of 48 hours which had been allowed to the Serbs. England and Russia were especially active in this sense. But Austria-Hungary refused any prolongation of the time-limit. On July 25, shortly before the expiry of the appointed interval, the Serbs handed in their answer. They declared themselves ready to comply with the majority of the demands of the Vienna Government, but with regard to certain points—for instance, where it was a question of the participation of the Austro-Hungarian representatives in the judicial enquiry to be held in the territory of the kingdom of Serbia, and of the dismissal of the officers and officials who were compromised—certain reservations were made; at the same time the Serbs emphasized their willingness to endeavour to reach a friendly solution of the conflict by referring the decision to the Hague Court of Arbitration, or to those Great Powers who had collaborated in the composition of the Serbian declaration of March 31 1909. But the Austro-Hungarian minister declared Serbia's answer to be unsatisfactory, and diplomatic relations were broken off between Vienna and Belgrade.

The Vienna Cabinet's harsh attitude nowhere met with approbation; the German Government itself did not approve it. The Emperor William indeed was of opinion that Austria-Hungary had gained a great moral victory, Efforts to Avert War and that no cause of war remained. But neither his efforts, nor those of Sir Edward Grey, which were directed towards the mediation of the Great Powers not directly involved, met with success. On July 28 Austria-Hungary declared war on Serbia. The Great Powers now strove to localize the conflict. But all their attempts came to naught. Even the English proposal for direct negotiations with a view to an understanding between the Cabinets of Vienna and St. Petersburg led to no result. On the evening of July 29 the order was given for mobilization in the military area on the S.W. front of Russia situated on the border of Austria-Hungary. On July 31 the Russian order for a general mobilization was issued, and answered by similar measures on the part of Austria-Hungary and Germany. On Aug. 2 Germany declared war on Russia, and the day after on France; on Aug. 4 England and Belgium on Germany; on the 6th Austria-Hungary on Russia; other Powers followed suit. The World War, The World War. so long dreaded by the Great Powers of Europe, had broken out.

The Central Powers had now to make sure of the aid of their allies and to win new combatants to their side. But the efforts which they made towards this end brought them little disappointment upon disappointment. The conversations which had taken place with Italy in July 1914 Attitude of Italy. had made them realize that they could not reckon on an immediate participation of the Italian troops on the side of the Triple Alliance. As early as July 25, moreover, San Giuliano had announced that he would open the question of compensation for Italy in case of an Austro-Serbian war. This announcement he repeated after the declaration of war, but made it clear at the same time that Austria-Hungary was not to expect active support from the Italians, since she had taken the offensive against Serbia. Under pressure from the German Government, which still cherished the hope of deciding Italy, by far-reaching concessions, to take part in a world war on the side of the Central Powers, Berchtold declared himself ready in principle to recognize the Italian claims to compensation for every annexation made by Austria-Hungary in the Balkans, but in any case only on the assumption that Italy would observe a friendly attitude towards the Habsburg Monarchy in an Austro-Serbian war, and in case of a world war fulfil her obligations as a member of the Triple Alliance. But as early as Aug. 1 San Giuliano insisted that the *casus foederis* had not arisen for Italy in the case of the Russians also; for the time being she would remain neutral; but coöperation with her allies at a later time was referred to as not excluded. It was in the same sense, though in the most cordial terms possible, that Victor

<sup>1</sup> A prominent part in the drafting of the ultimatum was played by Count Johann Forgach (b. 1870) and Baron Alexander Musulin (b. 1866), who had also, as Berchtold's advisers, a decisive influence on the course of events generally at this time.

Emmanuel answered the telegram in which Francis Joseph expressed his expectation of seeing the Italian troops fighting side by side with those of the Habsburg Monarchy.

Still less gratifying to Vienna were the reports which came in at the same time from Bucharest. The hopes which the Emperor William had built on King Charles's faithfulness to his treaty obligations were not realized.

*Attitude of Rumania.*

The Rumanian ruler evaded a decisive pronouncement as to his attitude in a world war; and Bratianu, the minister-president, did likewise. Czernin, the Austro-Hungarian minister at Bucharest, maintained that at first nothing but neutrality could be reckoned on on the part of Rumania, and insisted that the attitude of the Bulgarians and Turks, together with the course taken by the events of the war, would be decisive for any further action of the King and Government. It was significant that Bratianu spoke of the necessity of maintaining a balance in the Balkans, and at the same time pointed out the difficulties which would confront the King and the Government in consequence of the hostile attitude of influential Rumanian circles to the Magyars. It was in vain that Francis Joseph and William II. used their personal influence to try and persuade King Charles to take action in the sense they wished. No effect was produced even by the promise made by them to the King on Aug. 2, 1914 that they would help Rumania to obtain possession of Bessarabia, after the war had come to a successful end, if she would join in the struggle on the side of the Triple Alliance Powers. The crown council held on Aug. 4 decided that Rumania could not admit that the *casus foederis* had arisen. The assurance given by Charles at the same time, that he would safeguard the Rumanian frontiers and apprise Bulgaria that she would have nothing to fear from Rumania if she ranged herself with the Central Powers, could be of no greater comfort to his disillusioned allies than his solemn declaration that he would never consent to Rumania taking the field against Austria-Hungary.

The Central Powers were rather more fortunate in their quest for new allies than in their attempts to persuade Italy and Rumania to fulfil their engagements. On Aug. 1, 1914 the representatives of Germany and Turkey had signed a treaty by which they bound themselves to remain neutral in the conflict between Austria-Hungary and Serbia; but the *casus foederis* would arise at the moment when Russia entered the war. In this event Germany promised Turkey military support, and guaranteed her existing territorial position as against the Russians. By identical notes of Aug. 1, 1914 Austria-Hungary adhered to this treaty, which was to last till the end of 1918. But for the time being the Turks did not actively intervene, for their army was not yet properly equipped, and the influence of the friends of the Entente at Constantinople was still too strong. In order to strengthen the Government, which was friendly to the Central Powers, and to make it possible for them shortly to take an active part against the Entente, Germany promised them, as early as the first weeks of Aug. 1914, though only verbally, that in the event of a complete victory of Germany and her allies, their wishes should be furthered both in the matter of the abolition of the Capitulations and of final settlement with Bulgaria; that all Turkish provinces which might be occupied by the common enemy in the course of the war should be evacuated; a series of rectifications of the frontier to her advantage would be made, and they would receive a proportionate share in the war indemnity which was to be expected. Direct inquiries from the Turks were met by Berchtold with the same promises in the name of Austria-Hungary.

On the other hand, the efforts of the Central Powers to decide Bulgaria to an alliance broke down. At first, indeed, it looked as if the negotiations which had already been conducted by Austria-Hungary at Sofia for a long time in this sense would speedily lead to a profitable result. Austria-Hungary showed herself inclined, in return for Bulgaria's adhesion to the Triple Alliance, to guarantee her existing territorial possessions, and, in the event

of a favourable outcome of the impending conflicts, to gratify Ferdinand's aspirations towards the acquisition of "ethno-historical boundaries" against states which had not joined the Triple Alliance. By the early days of Aug. 1914 the negotiations had advanced so far that the signature of the treaties with Germany and Austria-Hungary seemed imminent. Berchtold and Bethmann Hollweg pressed for a decision, the latter more especially on the ground that he still hoped to win over Rumania definitely to the side of the Central Powers. If this could be achieved, then Bulgaria, assured against attacks from the Rumanian side, might be prompted to draw the sword against Serbia, and the majority of the Austro-Hungarian troops which were marching against Serbia could be diverted against Russia. But Ferdinand of Bulgaria refused to embark on a war against Serbia. He laid stress on the dangers which threatened his kingdom in such a case from Greece, Rumania and Turkey; he also alluded to the large offers which had been made him by Russia, and held that he could only come to a decision after his relations with Rumania and Turkey had been cleared up and the negotiations for a treaty with these Powers had been concluded. It was clear that Ferdinand of Bulgaria, too, did not wish to enter the war before the preponderance of the Central Powers over their opponents could be assumed with greater confidence. But successes in the field remained to seek in the Eastern theatre of war. After promising beginnings, the campaign of the Austro-Hungarian armies took an unsuccessful turn, and decided Ferdinand to be prudent. He declared that he would remain neutral, but for the present he could do no more.

But the ill success of the Austro-Hungarian armies did not produce an effect on the Bulgarian Government only. With the advance of the Russians and their approach to the Rumanian frontiers, the influence of the friends of the Entente at Bucharest increased. The news arriving at Berlin and Vienna at this time caused the worst to be feared. It was believed that an overthrow of the dynasty was imminent, together with an immediate alliance of Rumania with the enemy, and an advance of Rumanian troops into Transylvania. The most pressing advice reached Vienna from Berlin in favour of far-reaching concessions, even of a territorial nature. But, strongly influenced by Tisza, Berchtold refused any concessions in this direction. Under the advice of King Charles, who was already seriously ill, and was torn by a terrible conflict between personal honour and the wishes of his people, the Central Powers sought to work upon public opinion in Bucharest by a declaration that the defection of Rumania would be met by an immediate advance of troops into the country. But their threats remained ineffectual, for it was known in Bucharest that the troops necessary for such an enterprise were not forthcoming. In reality Germany was counselling Vienna not to oppose the march of Rumanian troops into Transylvania by force of arms, since for the moment a defence of the frontiers was impossible; but rather to tolerate the advance, and to announce that it had taken place in order to defend the territory from occupation by Russian troops. Berchtold refused, and Tisza, whose acrimony over the German proposals knew no bounds, declared that he would rather see the Russians than the Rumanians in Transylvania. Meanwhile the tide of warlike enthusiasm at Bucharest mounted higher and higher. The Government entered into a written agreement with Italy providing for common action on the part of both of them. A crown council was summoned for the early days of Oct., which was to come to a decision against the Central Powers. Only at the last moment was it possible to avert the danger. The crown council was cancelled, and Rumania for the time being remained neutral. A few days later, on Oct. 10, 1914, King Charles of Rumania died. He had not fulfilled the engagements into which he had entered, but he had at least successfully prevented his troops from fighting against the Central Powers.

One of the chief reasons which had delayed the Rumanians in going over to the camp of the Entente was the fear enter-

*Alliance with Turkey.*

*Negotiations with Bulgaria.*

*Central Powers and Rumania.*

tained by leading Rumanian politicians that so soon as her troops had crossed the Hungarian frontier Bulgaria and Turkey would attack Rumania. The negotiations carried on through the intermediary of Austria-Hungary between the Courts of Sofia and Bucharest had then, it is true, been proceeded with, but had broken down again, this time owing to the reciprocal distrust and the irreconcilable interests of the two Powers. At the same time it had become known to those in Bucharest how closely the Turks had attached themselves to the Central Powers, and that they were holding themselves in readiness to enter the World War on their side. Rumania consequently declared that she could no longer leave Bulgaria a free hand against Serbia. Thus under the new King of Rumania, Ferdinand, who was not bound by ties of personal friendship with the sovereigns of Austria-Hungary and Germany, the party hostile to the Central Powers gained in influence. Ferdinand did indeed stand firm in his neutrality, and he rejected Russia's summons to hasten to the aid of the Serbians, who had been attacked by Austria-Hungary. But Czernin could not succeed in obtaining from him a binding declaration that he would not let his troops enter the field against the Central Powers.

At this time Germany and Austria-Hungary were equally powerless to decide the King of Bulgaria to take part in the Serbian War. Even the increased inducements held out to him in this event by the Vienna Government did not move him from this attitude of reserve. This was due not only to his distrust of Rumania, Greece and

*Negotiations with Bulgaria.*

Turkey and his fear of Russia, but also to his doubt as to whether by joining the Central Powers he would really be placing himself on the winning side. Accordingly he was forever changing his attitude and that of his Government according to the vicissitudes of the war. If the armies of the Central Powers met with success, they all showed a growing inclination to bring the treaty negotiations, which had never been allowed to drop for a minute, to a conclusion. But if, as in Dec. 1914, unfavourable news reached Sofia as to the military situation of the Central Powers, then the old reasons for dragging on the negotiations were raked up again. The fact that the Entente Powers kept going further and further in their offers to Bulgaria, should she enter the war on their side or even should she remain neutral, contributed towards strengthening the resolve of the Bulgarian Government to put the screw on the Central Powers in the matter of their demands. Thus at the end of 1914 they demanded far-reaching concessions in the matter of their territorial claims, and that under a written promise. Austria-Hungary was refractory for a time, but at the beginning of 1915 declared herself prepared even for these concessions, but demanded, with the backing of the German Government, the armed intervention of Bulgaria on the side of the Central Powers. But neither King Ferdinand of Bulgaria nor Radoslavov, the Bulgarian minister-president, was willing to concede this, for the military situation of the Central Powers was for the moment unfavourable. They declared their wish to remain neutral.

The negotiations with Rumania and Bulgaria revealed the fact that both Powers, different though their interests might be, followed a similar policy. They wished to delay their decision as long as possible; they wished at the right moment to join the side of the winning party so as to carry off the greatest possible advantages at the price of the least possible sacrifices. In these circumstances the importance to the outcome of the war of Italy's decision increased every month. For a long time, until far on in the winter of 1914, the policy of leading Italian statesmen was dictated by the wish to preserve their neutrality while keeping up their armament. They accounted for their attitude by referring to the letter and the spirit of the Triple Alliance; they gave their former allies friendly words, but maintained a cordial attitude towards the Entente Powers. At the same time they urged at Vienna their demands for compensations by interpreting Article VII. of the Triple Alliance Treaty in their own favour. It was not at first clear what they meant by it. During

*Negotiations with Italy.*

the official negotiations which took place between the Cabinets of Vienna and Rome, no word was spoken on the Italian side of old Austrian territories. But it was learnt at the Ballplatz, by way of Berlin, that Italy was thinking of the Trentino. Berchtold absolutely refused to listen to any such demands. He would not hear of a territorial indemnification on any account, and was warmly supported in this by Tisza, while Conrad even at that time, or at any rate in times of military misfortune, considered that even Italian neutrality would not be too dearly bought at the price of great sacrifices. But neither the prayers of the leading military commander nor the unceasing efforts of leading German political and military circles were able to change Berchtold's mind. He went on, indeed, with the negotiations, but spun them out without binding himself to anything. When San Giuliano died on Oct. 16 1914, nothing decisive had yet happened. Even during the few weeks for which Salandra, the then Italian minister-president, directed Italy's foreign policy, no energetic steps were taken. Salandra fell in with the feeling of the country. It was not until Sonnino had taken over the leadership of Italy's foreign affairs that a further advance was ventured on by Italy in view of the unfavourable military position of the Central Powers, and under the influence of that section of the Italian press which was active in the interests of the Entente. It was once more reported in Vienna that Sonnino had spoken in Berlin of the cession of the Trentino, and that the German Government was now advocating this sacrifice. But even now Berchtold refused to entertain the question. Francis Joseph, so it was said, would never give his consent to a diminution of his empire. Only Sonnino kept on his way unperturbed. At the beginning of Dec. 1914—when Austria-Hungary was advancing upon Serbia—he had a declaration made at Vienna to the effect that the excited state of opinion in Italy compelled him to press for the adjustment of the question of compensations. Salandra supported him, by speaking in Parliament of Italy's *sacro egoismo*, her just aspirations and legitimate interests, and, while giving expression to the pacific character of the Italian Government, he stated emphatically that neutrality alone was not sufficient to assure Italy's interests in all circumstances until the end of the war.

In the middle of December the negotiations between Vienna and Rome began afresh, but at once came to a deadlock. The German Government, which attached extraordinary importance to winning over Italy, now tried to persuade the Ballplatz to make concessions. At the same time it sent to Rome Prince Btlow, who worked in the same sense, and represented concessions on the part of Austria-Hungary as a sacrifice, heavy indeed, but necessary in order to assure Italy's neutrality. But Berchtold was still resolutely opposed to such a demand, and expressed this view also in his direct negotiations with the Italian ambassador in Vienna, the Duke of Aviano.

Berchtold's fall from power, and the appointment of Baron Burian to succeed him as Austro-Hungarian foreign minister (Jan. 13 1915), made but little change in the position of the Vienna Government. Negotiations with Italy were indeed continued, but led to no *rapprochement* between the two opposing points of view. It was not till March 9 1915 that Burian expressed his willingness to discuss with Italy, in principle, the cession of Austrian territory. He did so under the impression of the unfavourable military position of the Triple Alliance Powers—the Russians were fighting in the Carpathians, and Przemysl was about to fall—and with the knowledge of the renewal in Feb. 1915 of the agreement between Italy and Rumania, which let it be feared that a declaration of war by Italy would be followed by that of Rumania; under increasingly heavy pressure, moreover, from the German Government, which, in the event of a favourable outcome of the war, held before the eyes of the Vienna Government, as compensation for the losses of the monarchy in Tirol, not only a loan in cash but also the rich coal-mines of Sosnovka.

The opening of negotiations at once showed how far the Italian demands exceeded what Austria-Hungary was now pre-

*Burian Succeeds Berchtold.*



pared to concede. Sonnino asked for wide territories and their immediate transfer to the Italians. Burian firmly refused the latter proposal, and only offered the greater part of Italian Southern Tirol, and even this on condition that Italy should preserve a benevolent neutrality towards the Central Powers until the end of the war and leave Austria-Hungary a free hand in the Balkans. Sonnino rejected Burian's offers as insufficient, and during the next few weeks increased his demands. On April 10, on Sonnino's instructions, a memorandum containing Italy's new conditions was handed in at Vienna. They made it clear that Italy was no longer striving to complete her national growth while preserving her former relations with the Habsburg Monarchy, but was aiming at the realization of her national unity and at the achievement of complete supremacy in the Adriatic. She demanded, among other things, the whole of S. Tirol, with the boundaries of the Italian kingdom of 1811, Gorizia and Gradisca, and the conversion of Trieste with its surrounding territory into a community independent of Austria-Hungary; the cession of a number of the most important islands in the Adriatic; the immediate occupation of these lands by the Italians; the recognition of the full sovereignty of Italy over Valona and its territory; and a declaration of Austria-Hungary's *désintéressement* as regards Albania. In return Italy was prepared to promise neutrality for the duration of the war, and to renounce for this period the construction in her own favour of the provisions of the Triple Alliance Treaty. In spite of the extent of these demands, they were not flatly refused by Burian, since the military situation compelled him to continue negotiations, and German statesmen and generals pointed out to him the disastrous consequences which would follow if Italy went over into the enemy camp. The fall of Constantinople was threatening, the Russians were pressing relentlessly forward, Hungary seemed at their mercy, and it might happen that a declaration of war by Italy would be followed by Rumania, and even by Bulgaria. Then the hemming-in of the Central Powers would be complete and the seal would be placed upon their ruin. Burian could not cast doubt upon these arguments; it was not without influence upon him that Conrad now advocated every concession to Italy. Burian therefore increased his concessions, but did not yield all that Italy demanded. He retreated, rather, step by step, always led by the hope that a new turn would be given to events in the theatre of war; he sought to hold the Italians in place without rebuffing them. But since the latter did not count upon achieving their demands from Vienna, and were convinced that the Habsburg Monarchy would take back again what had been squeezed from it in the hour of need, should the military situation take a more favourable turn, they determined to bring to a conclusion the negotiations which they had long carried on with the Entente Powers. On April 26 1915 the Treaty of London was signed, which pledged Italy to enter the war by the side of her new allies at the end of a month's interval. As compensation for this, it contained the assurance of an extension of territory for Italy going far beyond that which she had demanded from Austria-Hungary as the price of maintaining neutrality.

Having come to terms with the Entente Powers, Italy resumed negotiations with the Vienna Cabinet, not with the intention of pursuing them to any profitable end, but rather in order to find in the refusal of the Vienna Government to fulfil Italy's demands just grounds for going over to the enemy camp, and time to complete her warlike preparations. It was, therefore, in vain that Burian, under pressure of both the Austro-Hungarian and German army commands and of the German Government, went further and further in concessions to Italy. On April 21 1915 Sonnino declared that the points of view on either side were too wide apart for the differences to be bridged over; and on April 25 the Duke of Avarna, the Italian ambassador, who had up till then worked untriflingly for a friendly understanding, expressed his opinion that a breach was inevitable. Even Prince Billow, who continued the negotiations at Rome up to the last moment, let it be understood that he no longer believed the Italians to be in earnest in seeking a compromise.

On May 3 1915, in fact, the Italian council of ministers resolved to denounce the existing alliance with Austria and to claim full freedom of action for Italy. In vain the Vienna Cabinet made yet further concessions, so that in the end these included almost everything that the Italians had demanded. Sonnino continued indeed to negotiate, but he was always finding fresh reason for postponing a decision. On May 20 1915 the Italian Government received from the Chambers the extraordinary powers necessitated by the approaching conflict, and on the 23rd war was declared by Italy on Austria-Hungary.

One of the chief reasons which had decided Burian to offer such far-reaching concessions to Italy in April and May 1915 was the pressure from the military higher command, and especially Conrad, who never ceased to insist in his memoranda that Italy's entry into the war would be followed by that of Rumania, and on this account adjured Burian to make every sacrifice in order to avert the otherwise unavoidable catastrophe by winning over Italy. That his fears were well grounded was all the less doubtful, since it was already known in Vienna by Feb. 1915 that on Feb. 6-23 the agreement concluded in Sept. 1914 between Italy and Rumania as to their attitude in the war had been renewed for four months and had received an extension to the effect that the two Governments bound themselves to render each other mutual aid in the event of an unprovoked attack on the part of Austria-Hungary. The negotiations as to the cession of Austrian territory, which had been begun with Italy under the impression of this news, had now as their result that Rumania, too, raised the price of her continued neutrality. It was no longer only the Bukovina that was mentioned, but also Transylvania. But Tisza declared that he would not sacrifice a square yard of Hungarian soil, and the Vienna Cabinet agreed with him. The result was an increase of the influence of the Triple Entente in Rumania, which was further heightened by Russia's victories in the Carpathians and the breakdown of the negotiations conducted between Burian and Sonnino. The climax of this spirit of hostility to the Central Powers in Bucharest was reached on April 27 1915, when the Italian minister announced a declaration of war on the Habsburg Monarchy to be unavoidable. Only one thing could restrain Rumania, and decide her to maintain her neutrality: a great victory of the Central Powers over the Russians. And this now happened: the break-through at Gorlitz, on May 2 1915. Its effect was felt at once. Bratianu, the Rumanian minister-president, now declared that the position was indeed very critical, but that he hoped to contrive to maintain neutrality; further news of the successes of the German and Austro-Hungarian troops in Galicia and Poland contributed towards strengthening the Rumanian Government in their resolve not to give up their neutrality for the present. In these circumstances even the Italian declaration of war did not alter the Rumanian position, but the altered conditions of the war certainly influenced the attitude of the Vienna Government. Its interest in Rumania now sensibly declined, since her neutrality seemed assured by the military situation.

The desire of the Central Powers to arrive at a decision in their negotiations with Bulgaria became all the more urgent. Since Jan. 1915 the Turks had been successfully defending the Dardanelles against the attacks of the allied Western Powers, but their position was menaced by the fact that they lacked arms and munitions, which Germany had bound herself to provide by the terms of a treaty concluded on Jan. 11 1915, with which Austria-Hungary associated herself on March 21 1915. It was therefore necessary to establish secure communications with the Turks, and since all the efforts of the Central Powers to obtain the transport of arms and munitions through Rumania remained fruitless, it was necessary to try and make sure of a way through Bulgaria into Turkish territory. The adherence of Bulgaria would also give a further advantage. With Bulgaria in alliance with the Central Powers, Rumania would be less inclined to risk join-

Italy  
Declares  
War.

Reciprocal  
Attitude of  
Rumania.

Negotiations with  
Bulgaria.

ing their enemies, as in that case she would have to reckon with Bulgaria, which had not forgiven the wounds inflicted by the provisions of the Treaty of Bucharest in 1913.

It was not an easy matter for the Cabinets of Vienna and Berlin to win over the Bulgarians. Both the King and Radoslavov distrusted the Rumanians and Turks, and feared the Greeks and Russians. Moreover, the far-reaching offers of the Entente Powers were not without influence upon them. Their attitude in their dealings with the representatives of the Central Powers was guarded, and they kept increasing their demands. As early as the end of 1914 the Vienna Government, in view of the unfavourable military position in Serbia and Galicia, and in consequence of the pressure exerted upon it not only by the German politicians and military commanders, but also by Conrad, had declared its readiness to concede to the Bulgarians, in the event of their entry into the war on the side of the Central Powers, the possession of those Serbian territories to which they advanced historical and ethnographical claims; only, however, so far as they should occupy them with their own troops during the course of the war. The negotiations started at the beginning of 1915 on this basis were protracted by the Bulgarians, for in view of the unfavourable military situation of the Central Powers at the time, King Ferdinand and Radoslavov did not think it expedient to enter into permanent engagements. They therefore declared that they could promise only to remain neutral, but demanded in return considerable extensions of territory in Macedonia, increasing their claims in March and April under the impression of the Russian victories in the Carpathians and the danger threatening Turkey from the Western Powers. Burian, however, held firmly to the position that he could make territorial concessions only in return for active participation on Bulgaria's part. The breakthrough at Gorlitz and the subsequent victorious advance of the Germans and Austro-Hungarian troops also produced their effect in Sofia. The negotiations with the Central Powers were carried on with more zeal; but they failed to reach a settlement, since the demands of the Bulgarians continued to be out of all proportion to any services which they seemed disposed to offer in return. They declined to attack Serbia, refused a military convention proposed to them by the Central Powers, but at the same time increased the price of their continued neutrality. The entry of Italy into the war against the Central Powers, and the increasingly extensive offers on the part of the Entente, added to the difficulty of the negotiations between Vienna and Sofia. But gradually the conviction gained ground in Sofia that adherence to the Central Powers would serve the interests of Bulgaria better than an alliance with the Entente. For it would be easy for the former to concede the extensions of territory desired by Bulgaria in Macedonia at Serbia's expense, whereas the Entente Powers were bound to fear that similar concessions on their part would give offence to their faithful ally Serbia. The Triple Entente failed in their efforts to persuade the Serbs to consent to this sacrifice by promising them, in the event of ultimate victory, the possession of Bosnia, Herzegovina and Dalmatia, for Bulgaria demanded immediate possession of the Macedonian territories promised her, while Serbia wanted the transfer of these territories to be postponed until she herself should have secured the extension of territory promised to her by way of compensation.

It was only when the continued victorious advance of the Germans and Austro-Hungarians in Poland made the prospects of the ultimate victory of the Central Powers in the World War seem very favourable, that the advantage to be gained by joining them was definitely recognized at Sofia. From July 1915 onwards negotiations were energetically carried on. The Central Powers insisted on the signature of a military convention in addition to the treaty of alliance, and that Bulgaria should at the same time conclude a treaty with the Turks. After innumerable difficulties had been surmounted, the treaties between Austria-Hungary and Bulgaria were signed on Sept. 6 1915. The most important article of one treaty contained a guarantee by Austria-Hungary of

the independence and integrity of Bulgaria against any attack not provoked by Bulgaria herself, this guarantee to be valid for the duration of the alliance, i.e. till Dec. 31 1920, and after that for a year, and so on until the treaty should be denounced in proper form. Bulgaria, for her part, undertook to give Austria-Hungary proportionate armed assistance in the event of the monarchy being attacked by a State bordering on Bulgaria, and demanding her aid. The second agreement, signed on the same day, contained a pledge from Bulgaria that she would take the offensive against Serbia, in return for which what is now Serbian Macedonia—the so-called "disputed" and "non-disputed" zones, as established by the Serbo-Bulgarian Treaty of March 13 1912—was promised to her. In the meantime it was agreed that, in the event of an attack by Rumania on Bulgaria or her allies—including the Turks—which should not have been provoked by Bulgaria, Austria-Hungary would consent to the recovery by Bulgaria of the territory ceded by her to Rumania by the Peace of Bucharest, and a rectification of the Rumanian-Bulgarian frontier as defined by the Treaty of Berlin. A similar promise was made to Bulgaria, under the same conditions, with regard to the territory ceded by her to Greece by the Peace of Bucharest. The military convention signed on the same day settled the provisions for the carrying-out of the impending joint offensive against Serbia. The negotiations between the Turks and Bulgarians, which had been going on for a year past, were also brought to a conclusion on Sept. 6, thanks to persistent pressure from the Central Powers. Turkey gave in on the essential point by agreeing to a rectification of the frontier in favour of Bulgaria on both banks of the Maritsa.

The significance of the adhesion of Bulgaria to the Central Powers lay in the facts that it secured their communications with Turkey, and also the possibility of a victorious campaign against Serbia. The campaign now began and proceeded according to programme. Though valiantly defended by the Serbs against overwhelming numbers, their country fell, towards the end of 1915, into the hands of the Central Powers and Bulgaria. Shortly afterwards Montenegro shared the same fate.

The year 1915 also brought "Congress Poland" into the possession of the Central Powers. After the fall of Warsaw (Aug. 5 1915) General Governments were set up on behalf of Germany at Warsaw and on behalf of The Polish Question. Austria-Hungary at Lublin, to which all governmental powers were handed over. At first the Central Powers had not contemplated the permanent acquisition of "Congress Poland." It was merely considered as a pawn and an item for compensations at the end of the war. But after the fall of Warsaw, the Cabinets of Vienna and Berlin tried to arrive at an agreement as to the future destiny of Poland. The most diverse solutions were discussed, but no definitive agreement was arrived at by the end of the war. The idea of handing Poland back to Russia was indeed repeatedly advanced by Germany—both in the year 1915 and again very actively after July 1916—when Stürmer was at the head of foreign affairs in the empire of the Tsar. But since the condition of such a solution—namely a total separation of Russia from the Entente—could not be brought about, it was allowed to drop. The plan of dividing the whole of the conquered territory of Poland between Austria-Hungary and Germany was also considered. But insuperable difficulties arose in the course of the negotiations, particularly with regard to the frontiers of the respective territories. It was also foreseen that the Poles would not voluntarily submit to a new partition of their country and that they would struggle for its reunion. It was feared, moreover, that far-reaching differences between the Allies would be revealed the moment economic and military questions should come under discussion. The idea of annexing "Congress Poland" to Germany, first ventilated by a section of public opinion and in military circles in Germany, was rejected not only by the Vienna Cabinet but also by the German Imperial Chancellor, since he feared the increase of Polish influence in Germany that would be bound to follow. The plan advocated for a time by Bethmann Hollweg,

of founding an independent Polish buffer state, which should be in economic, political and military alliance with the Central Powers, also split upon the opposition of the Vienna Government. Thus the union of "Congress Poland" with the Habsburg Monarchy, which Burian had proposed in Aug. 1915, and which had been advocated by the writings of Count Andrássy among others, stood out more clearly as the only possible solution of the Polish question. But this, too, presented great difficulties on closer examination. There were adherents of the idea of a personal union and on the other hand of an actual union; among the latter were those who were in favour of a triallistic form for the new greater Austria-Hungary, and those who advocated the incorporation of Poland in the Austrian State.

Under the influence of the Hungarian Government, whose spokesman, Count Tisza, protested in the strongest terms against the organization of the monarchy on a triallistic basis, the idea now prevailed of annexing Poland to Austria-Hungary and granting to the entire territory of Poland, with the addition of Galicia, a far-reaching autonomy. This had the further object of diminishing the damage to the interests of the German-Austrians which was feared by wide circles in Austria and Germany. Since the autumn of 1915 negotiations were carried on between leading statesmen of Germany and Austria-Hungary on this basis. But the more deeply the question was gone into the greater were the difficulties which presented themselves. Bethmann Hollweg declared that the German people could only agree to such a strengthening of Austria-Hungary in the event of the German Empire coming out of the war with an equally large increase of territory. Economic and military objections were also advanced on the German side, and as a solution it was proposed to incorporate a small portion of "Congress Poland" with Austrian Galicia, and out of the greater part of the rest to create a Polish State independent in form but in reality under the protectorate of Germany. But this proposal was firmly rejected by the Vienna Government, which for its part advanced the idea of a genuinely autonomous State comprising the whole of Polish territory, which should be allied by a long-term economic and military agreement with both the Central Powers equally. But it was impossible to win the consent of the Berlin Government to this plan.

Such was the position when the Austro-Hungarian troops were defeated at Lutsk. The result of this was that in Aug. 1916 the Germans carried the day with their proposal to found an independent State, practically comprising the former "Congress Poland" under a hereditary constitutional monarchy, but subject to the most far-reaching limitations in military and economic matters. On the Austro-Hungarian side the bestowal of the crown of Poland on a member of the family of Habsburg-Lorraine was waived. A more exact definition of the sphere of influence of the Central Powers was reserved for further discussion. But their subsequent course showed that the opposition of interests was too deep-seated for it to be possible to settle matters in a hurry. In Oct. 1916, therefore, they came to an agreement for the present to shelve the question of an independent Polish State. But in order to calm the Poles, who were anxious about their fate, and to secure the assistance of their armed forces for the Central Powers, a proclamation was issued on Nov. 5 1916, in which a prospect was held out of the restoration of an independent Poland as a hereditary constitutional monarchy closely attached to the Central Powers. But the two military governments at Warsaw and Lublin continued to administer the country.

Even before this agreement had been arrived at, Rumania had actually gone over to the Entente camp. The Central

*Rumania joins the Entente.*

Powers had indeed not been wanting in offers to the Rumanian Government between Italy's entry into the war (March 1915) and the conclusion of the treaties with Bulgaria (Sept. 1915), but had made their concessions conditional on the active intervention of Rumania on their side. But the leading statesmen of Bucharest would not agree to this; for in spite of the great military successes of the Central Powers, their final victory seemed to them doubt-

ful. They accordingly continued to insist on important cessions of territory in the Bukovina and Transylvania by Austria-Hungary in return for a continuance of their neutrality. To this, however, Burian, strongly influenced by Tisza, refused to agree, although not only the German Government but also Conrad von Hötzendorff actively supported Rumania's demands. Thus the negotiations, which had been reluctantly continued by Burian, remained without results. Even Bulgaria's adhesion to the Central Powers, and the successful campaign against Serbia, did not produce any change in the attitude of the two Governments. The majority of Rumanian politicians counted on a rapid change in the military situation, and the Entente diplomatists made every effort to confirm them in this belief. But the Rumanian Government maintained its conviction that it must for the present preserve its neutrality. It was the Russian victories at Lutsk and Okna which first led to a change in their views. At the end of July 1916 the Vienna Cabinet was aware, from its ambassador, Count Czernin, that preparations for war were being completed in Bucharest, that negotiations were being carried on with the Entente Powers as to the conditions of going over to them, and that the probability was that Rumania would draw the sword as soon as the harvest was garnered. In spite of this, and though the news during the next few weeks was more and more unfavourable, Burian firmly refused the demands made by Rumania for the maintenance of their neutrality, and was not to be moved from his resolve even by the German Government and Conrad von Hötzendorff. And so towards the end of August the union of Rumania with the Entente Powers was accomplished, in return for far-reaching territorial concessions granted by them to their new ally at the expense of the Austro-Hungarian Monarchy. On August 27—on the day of Italy's formal rupture with Germany—followed Rumania's declaration of war on Austria-Hungary, and hostilities began without delay. But the hope of the Entente that Rumania's entry on their side would quickly decide the war in their favour was not fulfilled. After preliminary Rumanian successes against the weak troops of the Habsburg Monarchy, the armies of the Quadruple Alliance, fighting under German leadership, achieved a decisive victory. On Dec. 6 1915 Bucharest was taken, and at the beginning of Jan. 1917 two-thirds of Rumania was occupied.

Turkey's danger had grown through the entry of Rumania into the war on the side of the Entente Powers. She, therefore, addressed herself to the Central Powers with fresh demands. So early as Sept. 28 1916 Germany assumed the Porte that, in accordance with her treaty engagements, she would not conclude a separate peace, would allow Turkey a share, proportionate to her military efforts, in any territorial conquests, and would not agree to any peace so long as Turkish territory was occupied by the enemy. Soon afterwards, on Jan. 11 1917, a further agreement was arrived at between these two Powers, in which the abolition of the Capitulations, which Turkey found oppressive, was contemplated. The provisions of these two treaties were expanded in a manner favourable to Turkey on Nov. 27 1917. The Austro-Hungarian Government, after long hesitation, associated itself on March 22 1917 with the German settlements of Sept. 28 1916 and Jan. 11 1917. But her ratification was not given. A treaty was signed between Austria-Hungary and Turkey on May 30 1918 as to the question of the Capitulations, which corresponded to the Turco-German one of Nov. 27 1917, and by which Austria-Hungary pledged herself not to sign any peace which should reestablish the Capitulations.

*New Agreements with Turkey.*

The success of the Central Powers in Rumania was a ray of light in the last days of the Emperor Francis Joseph I., who had entered the war with a heavy heart, and always remained full of anxious care as to the fate of his empire. His armies and those of his allies had achieved decisive victories in several theatres of war in the course of the year 1916; they had occupied new territories, and in other quarters had successfully repelled the increasingly formidable offensive of their enemies. The battles on the

*First Peace Proposal.*

Isonzo had thrown the heroism of the Austro-Hungarian troops into particularly clear relief. But the number and military efficiency of their enemies increased, and since Great Britain commanded the sea and the United States supported them more and more lavishly, the Entente armies had at their disposition vast masses of arms and munitions of every kind and also immense supplies of foodstuffs. The Central Powers, thrown back upon their own industrial resources, and hampered in the import of foodstuffs and the production of weapons by the British blockade, could not keep pace in the race. For this reason the desire to put an end to this interminable struggle of the nations grew from month to month, especially in Austria-Hungary, where from the beginning of the war a great part of the population had only fought unwillingly for interests which were not regarded as their own. In the course of the year 1914 Francis Joseph, for his part, had not refused to listen to suggestions for a peace which should take into account the most important interests of his empire; he had approved the numerous proposals for peace which in the years 1915-6 had come from more or less authoritative quarters; but he had always insisted most strongly that these negotiations must be conducted in full agreement with his allies, and especially with Germany. But all these peace proposals had proved abortive, since neither Germany nor Austria-Hungary saw the possibility of ending the war on any terms commensurate with the military situation and their desires. But in Oct. 1916, in order to prove to the public opinion of the world that it was not the insatiability of the Central Powers which stood in the way of peace, Burian proposed to the German Imperial Chancellor, at the general headquarters at Pless, that the Quadruple Alliance should inform their enemies, through neutral channels, of their conditions of peace, and also publish them, in order to enlighten their own peoples as to their war aims and win over the neutral Powers to an active intervention with the enemy Governments. Bethmann Hollweg and the other German statesmen agreed in principle with Burian's idea. But they declined, for their part, to communicate their concrete peace conditions, since they felt themselves bound, especially in the Belgian question, to advance demands which their enemies, and especially Great Britain, could not possibly accept. On this point

*Strained Relations with Germany.*

excited debates took place and serious conflicts between the Vienna and Berlin Cabinets, in the course of which the Austrians demanded the recall of Tschirschky, the German ambassador at the Court of Vienna, who represented the German point of view with uncompromising harshness. Even the sovereigns of Austria-Hungary and Germany took part in this conflict. The Emperor William sought insistently to convince his ally that Germany could not fall in with Burian's plan. It was one of Francis Joseph's last acts to invoke every means in order to accomplish a settlement of the outstanding difficulties. It was only after long negotiations—Francis Joseph having in the meantime died on Nov. 21 1916—that it was possible to reach a compromise. It was agreed to submit the proposal of the Quadruple Alliance to their enemies through the neutral Powers, and immediately to enter upon deliberations as to a peace, in which the peace conditions of the Quadruple Alliance should be exactly defined.

The death of Francis Joseph and the accession of the Emperor Charles to the throne of Austria-Hungary notably reinforced the peace party at Vienna. In his very first declarations Charles emphasized his firm intention of doing everything in his power to put an end to the terrible world conflict. In this attitude he was most strongly confirmed by his wife, Zita, by her mother, the influential Marla Antonia of Parma, and by his brothers-in-law, Sixtus and Xavier. On Dec. 12 1916 the peace offer of the Quadruple Alliance was made public. It contained a promise to submit to a conference of the Powers proposals which should aim at assuring to their peoples existence, honour, and freedom of development, and at laying foundations calculated to establish a lasting peace. In conversations with Germany, Austria-Hungary defined her standpoint as follows:—She claimed the integrity of her territory, tri-

pling frontier rectifications as against Russia, a more favourable strategic frontier against Rumania, the cession to Austria-Hungary of a small portion of the territory of the Serbian Monarchy and of larger portions to Bulgaria and Albania, and a more favourable strategic frontier against Italy; in addition to this the economic union of Serbia with the Habsburg Monarchy, and Albanian autonomy under an Austro-Hungarian protectorate. Independently of the peace activity of the Quadruple Alliance, Mr. Woodrow Wilson, who had shortly before been re-elected President of the United States, on Dec. 18 1916 invited the belligerent Powers to communicate their peace terms, and had a note handed in at London in this sense on Dec. 21. Both proposals, however, were declined by the Entente Powers. On Dec. 30 1916 Briand, on the part of France, declared the peace offer of the Quadruple Alliance to be a war manoeuvre, and that all negotiations were useless, so long as no security was given for the restoration of violated rights and liberties and the recognition of the right of peoples to self-determination. In the note drawn up in concert by the Entente Powers on Jan. 12 1917, in answer to President Wilson's communication of Dec. 18, all the blame for the outbreak of war was imputed to the Central Powers, and the demand was formulated, among other things, for compensation for all war damages, the restoration of Alsace-Lorraine to France, and from Austria-Hungary in particular proportionate cessions of territory to Italy as well. The German Government, which had by now fallen into more and more obvious dependence on the higher army command, thereupon resolved to carry on the war by the employment of the most extreme measures, the most important and most promising of which was indicated in authoritative quarters to be unlimited submarine warfare.

Baron Burian, meanwhile, had ceased to be Austro-Hungarian foreign minister on Dec. 22 1916, being succeeded by Count Ottokar Czernin, the former ambassador at Bucharest. Austro-Hungarian statesmen generally did not share the exaggerated expectations of German military circles as to the effects of the submarine campaign, and Czernin in particular gave open expression to his doubts about the subjugation of England within a few months, which the German authorities seemed to regard as certain. He drew attention to the danger of an active intervention of the United States, if unlimited submarine warfare were entered upon. The Emperor Charles shared his minister's views. But the continual pressure of German statesmen and the German higher command, powerfully supported by the Emperor William, at last succeeded in obtaining the consent of the Austro-Hungarian Government to the unlimited submarine warfare. The war was resumed by Germany and her allies by land, by sea and in the air. But the hope of forcing their enemies to their knees by decisive successes was not realized. During the year 1917 there were indeed moments in which it looked as if the final decision would be in their favour. But their enemies, in spite of all the successes of the Central Powers and their allies, rejected all thoughts of a peace unsatisfactory to them.

*German Successes.*

The opening of unlimited submarine warfare was followed immediately by the rupture of diplomatic relations between the Cabinets of Berlin and Washington, and on April 6 1917 by the declaration of war on Germany by the United States. It was not till Dec. 7 1917 that the United States declared war on Austria-Hungary. Meanwhile, since the successes of the submarine warfare, though in themselves considerable, did not produce the result foretold by Germany, the Emperor Charles's inclination towards peace grew from month to month. Under the influence of his *entourage* he determined, by secret negotiations with the enemy, to work for a peace which should include a guarantee of the integrity of the Habsburg Monarchy by the Entente Powers. His brother-in-law, Prince Sixtus of Bourbon Parma, undertook the rôle of mediator. On March 24 the Emperor Charles empowered him, by letter, to declare to M. Poincaré, President of the French Republic, that in order to obtain peace he would

*American Declaration of War.*

*Secret Peace Proposals.*

exert every effort in his power to support the just claims of France to Alsace-Lorraine *vis-à-vis* his allies. In other questions too, notably in that of Belgium, the Emperor Charles showed a wish to further the desires of the enemy Powers as far as possible. On the other hand, there was no mention in Charles's letter of any readiness to cede Austrian territory to Italy. Count Czernin, who was well informed as to essentials in the negotiations, but was unacquainted with the text of the imperial letter, endeavoured in the meanwhile to win over the German Government to the idea of peace. On March 27 1917 an agreement was signed at Vienna between him and Bethmann Hollweg which provided for a minimum and maximum programme. In the former the restoration of the territorial *status quo ante bellum* of the Central Powers in the E. and

German Peace Programmes, 1917.

W. was laid down as the condition precedent to their evacuation of the occupied provinces of Russia (except Poland), Serbia, Albania, Greece and Rumania; in the latter, which was to hold good in the event of the war taking a more favourable turn, provision was made for a permanent acquisition of enemy territory in proportion to their respective military achievements. In this event Germany's field of expansion was to be in the East, Austria-Hungary's in Rumania.

Shortly afterwards, April 3 1917, the Emperor Charles and Count Czernin arrived at Homburg as guests of the Emperor William. Czernin here came forward with a proposal (the connection with Prince Sixtus's *démarche* being noteworthy) that Germany might make concessions to France in Alsace-Lorraine, and as a substitute for her losses in the West take permanent possession of a Poland supplemented by Galicia. These plans found a basis in the prospect of concluding a favourable peace with Russia, which had opened up shortly before the abdication of the Tsar Nicholas II. in March. To reinforce his efforts, Count Czernin, on April 14, sent to the Emperor William a report, drawn up by himself and the Emperor Charles in person, in which the internal situation of the Habsburg Monarchy was painted in the blackest colours, and its collapse, involving a revolution and the downfall of the dynasty, was represented as imminent. At the same time Czernin renewed in authoritative quarters in Germany his offer to compensate the German Empire for eventual losses in Alsace-Lorraine by the permanent acquisition of Poland enlarged by the addition of Galicia. But the Emperor William and his counsellors refused to open negotiations with the enemy on this basis, and urged the continuation of the war. It soon afterwards became clear that the secret negotiations conducted by Sixtus of Parma with the Entente Powers would not lead to the results desired by the Emperor Charles and Czernin. For Italy held by her bond, and demanded the cession of all those provinces of the Habsburg Monarchy which had been promised her by the Treaty of London of April 26 1915. To this, however, the Emperor Charles, particularly in view of the military situation at the time, neither would nor could consent.

The negotiations with the Western Powers having thus for the present led to no tangible results, the Emperor Charles and Count Czernin decided at Kreuznach (May 17-18 1917) to come to an agreement with the German Government, in which there was no further mention of the cession of Alsace-Lorraine, but in which it was stipulated by Austria-Hungary that not only should her integrity be guaranteed but she should receive considerable accessions of territory in the Balkans. Germany, furthermore, agreed in the event of her being able to carry out "the territorial incorporation (*Angliederung*) of Courland and Lithuania, together with the dependence (*Anlehnung*) of Poland contemplated on the German side," that "Rumania so far as occupied, with the exception of the Dobruja (frontier anterior to 1913) and a border strip to the S. of the Cernavoda-Constanza railway, falls as a separate State into the Austro-Hungarian sphere of interests, subject to a guarantee of Germany's economic interests in Rumania." On the fulfilment of these conditions Austria-Hungary consented to renounce her condominium in

Poland, and promised to declare her *désintéressement*, political and military, in Poland. On June 8 1917 the Emperor William II. and Charles signed an agreement as to Poland's military forces, by which their organization was placed entirely in the hands of Germany.

The war continued. The Quadruple Alliance waged it with the exertion of all its military strength, and even now gained not inconsiderable successes. On the western front the Germans held at bay the attacks of the French and British troops, lavishly furnished with war material. <sup>Growing War Weariness.</sup> On the eastern front the armies of the Alliance fought successfully against the Russians. In the S. the armies of Austria-Hungary, stiffened by German troops, undertook an invasion of Italy which led to the occupation of further Italian territory. But all these successes did not suffice to compel a desire for peace on the part of the enemy, while, in the countries of the Quadruple Alliance, war weariness, furthered by a skilfully managed propaganda on the part of the Entente, kept spreading to wider circles among the soldiers and citizens of the Central Powers and their allies. This feeling among the people, and the recognition of the fact that the war could only be ended by diplomatic means, decided Czernin to resume with the greatest energy his efforts to achieve a peace which should preserve the vital interests of the monarchy. In this he was strongly supported by the declaration made by the majority in the German Reichstag on July 19 1917 in favour of a peace by agreement, in which the forcible acquisition of territory, and oppressive political, economic and financial measures were repudiated, and the freedom of the seas and the renunciation by the enemy of the economic blockade of the Central Powers were demanded. Yet neither the Pope's official efforts for peace nor the secret Reverters-Armand (July-Aug. 1917) and Menadorff-Smuts (Dec. 1917) negotiations led to tangible results, since the enemy had exact information as to the critical internal situation of the Powers of the Quadruple Alliance, and, counting upon the strong support of the United States for the following year, made conditions to which, in view of their favourable military situation at the end of the year 1917, Germany and her allies would not accede. At this time, moreover, the prospect was opening to them of concluding a favourable peace with their enemies in the E. which would enable them to fall with their full strength upon their enemies in the West.

The revolution which had taken place in Russia in March 1917 had not brought peace; on the contrary, the numerous negotiations which took place between the Central Powers and Russia, having as their aim the conclusion of a separate peace, dragged on inconclusively. The war went on; it was waged successfully by Germany, and brought wide territories in the East into the possession of the allies. But a decisive change took place for the first time in the attitude of the Russian politicians in Nov. 1917, when the second phase of the Russian revolution—the "social revolutionary" phase led by Kerensky—was succeeded by a third, that of the "Bolsheviks," led by Lenin and Trotsky. As early as the end of Nov. 1917 the new Government summoned all the combatant Powers to enter immediately upon an armistice and begin negotiations for the conclusion of a general peace, which should assure to every nation freedom of economic and cultural development. When the Entente Powers refused to comply with this summons, the Russians on Dec. 3 entered into a suspension of hostilities with Germany and her allies, which was to last till Dec. 17. On Dec. 15 the suspension of hostilities was succeeded by an armistice, which was to last till Jan. 14 1918 and then be continued with the right to denounce it on seven days' notice. Peace negotiations began on Dec. 22 at Brest-Litovsk. They were conducted in public. The upshot was that on Dec. 25 the Quadruple Alliance accepted the Russian proposals for the conclusion of a peace without annexations and indemnities as the basis for a general peace. At the suggestion of the Russian delegates, the negotiations were suspended for ten days and a request was addressed to the enemies of the Quadruple All-

Effect of Bolshevik Revolution

Negotiations at Brest-Litovsk.

since that they should take part in further deliberations on the basis of the resolutions adopted on Dec. 25. But the Entente Powers refused. Thereupon negotiations were begun (Jan. 9 1918) for a separate peace between Russia and the Quadruple Alliance. But they did not run so smoothly as the majority of Austro-Hungarian politicians had hoped. Trotsky, the chief of the Russian delegation, demanded full freedom for the plebiscites to be held in the Russian provinces occupied by the Central Powers, and with this object proposed that their troops should evacuate them. On the rejection of this proposal by the German and Austro-Hungarian delegates, Trotsky protracted the negotiations in order meanwhile to introduce Bolshevik ideas into the territories of the Quadruple Alliance. The progress of the negotiations was hampered by quarrels among the Russians, and by the appearance at Brest-Litovsk of an Ukrainian delegation which pressed for the establishment of a Russian federal republic. Since on this question no agreement could be reached, the representatives of the Ukraine, on Jan. 24 1918, announced the complete independence of the Ukrainian People's Republic, and on Feb. 9 concluded a separate peace with the Quadruple Alliance, which, so far as Austria-Hungary was concerned, left the frontier between the two States unchanged. Inspired by his eagerness to bring to the starving population of Austria, and above all to the inhabitants of Vienna, the longed-for "bread peace," which stipulated for the delivery of foodstuffs from the Ukraine, Czernin, in compliance with the violent desire of the Ukrainian delegation, carried out their demand for the incorporation of the district of Cholm in the newly created republic, and for the erection of East Galicia into an autonomous Austrian crown territory.

The negotiations with Russia had meanwhile been continued. Czernin, zealously seconded in his efforts for peace by the Emperor Charles, pressed for a conclusion, but met with determined opposition from the German negotiators. On Feb. 10 1918 Trotsky declared that Russia, renouncing a formal treaty of peace, regarded the state of war against the Quadruple Alliance as at an end, and would reduce her troops to a peace footing on all fronts. But since this solution did not meet with the whole-hearted consent of the Central Powers, Germany resumed the struggle. The Austro-Hungarian troops did not enter into the war against Soviet Russia, but after a few days joined the march of the German troops into the Ukraine. The Russians, defeated by Germany in the field, now changed their tactics and declared themselves prepared to conclude a formal peace, which was signed on March 3 1918 at Brest-Litovsk. It brought the Habsburg Monarchy no accessions of territory, but, by the official retirement of the Russians from the ranks of their enemies, it involved a considerable strengthening of the Quadruple Alliance.

Poland had become independent of Russia by the provisions of the Peace of Brest-Litovsk; but this did not settle the Polish question. The negotiations conducted by the Cabinets of Vienna and Berlin as to the fate of Poland in the spring and summer of 1917 led to no issue, since the conflicting interests of the two Powers concerned were shown to be irreconcilable. The plan advocated by Austria, that the Archduke Charles Stephen should be made regent, and afterwards king, was accepted neither by the Emperor William nor by the German Government. In the autumn of 1917 the decision made earlier in the year to abandon Poland to Germany and compensate Austria-Hungary in Rumania was given up, and the Austro-Polish solution advocated by the Emperor Charles and Czernin was approved in principle. In the negotiations which followed as to the carrying-out of this plan, however, the old opposition of interests again became apparent. Germany declared that she would make her acquiescence in the Austro-Polish solution contingent upon the cession to her of large portions of Polish territory, as "rectifications of frontier," and, beyond this, upon her retaining a decisive influence upon the utilization of the economic and military

forces of a Polish State which was not to be incorporated in Austria-Hungary but merely joined to her by a personal union. To this, however, the Vienna Government would not agree, and once more the attempt to reach a definitive solution of the Polish question had broken down. The Poles, anxious about their future and keenly desirous to make it as favourable as possible to themselves, took advantage of these differences to continue negotiations with both sides, in order to secure for their State the widest possible territorial extension and the greatest possible measure of independence. They resolutely protested against the cession of the district of Cholm to the Ukraine; and on March 4 1918, with the aid of the Poles in the Habsburg Monarchy, they succeeded in obtaining the signature, by the Powers concerned in the conclusion of the Peace Treaty of Feb. 9, of a protocol in which it was laid down that the frontiers between Poland and the Ukraine were to be settled by a new agreement, arrived at with the coöperation of the Poles, and perhaps to be altered in favour of the Poles. The negotiations between the Cabinets of Vienna and Berlin as to the future destiny of Poland still went on. The former clung to the Austro-Polish solution, but it was evident from many indications that the German Government showed less and less inclination to consent to it. In July 1918, after the luckless Austrian offensive in Italy, the German Imperial Chancellor, Count Hertling, declared that he would no longer recognize the Austro-Polish solution. Poland was to have the free choice of her future form of government, but before its establishment must come to arrangements with the Central Powers, pecuniarily calculated to secure their economic and military interests. Austria-Hungary agreed with these proposals in principle. But the negotiations which were now entered upon led, like all the preceding ones, to no definitive results, though they provided the Poles once more with the desired opportunity for fishing in troubled waters.

The ending of the war between Russia and the Quadruple Alliance also compelled Rumania to conclude peace with the victors, having already, on Dec. 17 1917, had to submit to an armistice. After rather long negotiations the peace preliminaries were signed at the château of Buftea near Bucharest on March 6 1918, and on May 7 the definitive peace; but the latter was not ratified by Rumania. Austria-Hungary received a favourable strategic frontier in the Carpathians, important economic concessions, and the promise of an immediate evacuation of the provinces of the Habsburg Monarchy still occupied by Rumania. King Ferdinand had to thank the personal intervention of the Emperor Charles for the fact that he retained his crown.

The successes in the East, gratifying though they were in themselves, did not deceive the governing circles at the Ballplatz as to the danger on the verge of which they hovered. They knew that the filling-up of the seriously depleted ranks of the troops, the production of arms and munitions, the provisioning of the soldiers and of the population, would get more difficult every month. Reports kept coming in as to the increasing war-weariness of the troops, and the more and more openly expressed anti-dynastic sentiments of the non-German or non-Magyar portions of the population of the monarchy, as to the correctness of which there could be no doubt. All these reasons increased the desire of the Emperor Charles and of Czernin to bring the war to an end as quickly as possible. As early as the autumn of 1917 the German Government had been informed from Vienna that Austria-Hungary's strength was exhausted, and insistently urged to sacrifices which might content the enemy. The same point of view had been adhered to during the negotiations at Brest-Litovsk. Germany was to find in the East compensations for the cessions which she must make in the West in order to bring the enemy round the peace-table. For the negotiations secretly carried on by several Austro-Hungarian statesmen with the representatives of the Entente States had left no doubt as to the fact that there could be no thought of a serious entry upon peace negotiations on the part of the Western Powers before

*Treaty with the Ukrainians.*

*Peace of Brest-Litovsk.*

*Peace Treaty with Rumania.*

*Exhaustion of the Monarchy.*

*The Polish Question, 1917.*



Germany should have handed in precise declarations which should meet their views in the questions of Belgium and Alsace-Lorraine. It was, then, very opportune for the Court of Vienna when President Wilson, in his message to Congress of Jan. 8 1918, defined the Fourteen Points, in which he perceived a suitable basis for the establishment of a lasting peace. It is true that several of these points involved considerable damage to Austro-Hungarian interests; but in their entirety they seemed to afford Czernin the possibility of initiating peace negotiations.

He endeavoured in divers ways, and especially through the mediation of the King of Spain, to enter into negotiations with President Wilson, but failed to attain his end. Equally fruitless were the informal conversations carried on by Austro-Hungarian representatives, in intelligence with their Government, with French delegates in Switzerland and other places. Czernin firmly refused the demand of the Western Powers for the conclusion of a separate peace; but he continued his efforts at negotiation, though he knew that German headquarters had prepared a new campaign in the West which was intended to be decisive.

At the beginning of April 1918, shortly after this German offensive had successfully begun, Czernin emphasised, in an address to a delegation of the Viennese town council, his loyalty to Germany, as proved by his rejection of the French peace offers, which were conditional on the recognition of France's claims to

*Burian  
again  
Foreign  
Minister.*

Alsace-Lorraine. Clémenceau, the French prime minister, declared this assertion to be a lie, and, in the course of the publicist feud that followed, published among other things the letter of the Emperor Charles to Prince Sixtus of March 24 1917, in which he alluded to his willingness to advocate with his Allies France's "just claims" to Alsace-Lorraine. The Austro-Hungarian monarch's loyalty to his alliance was thus placed in an equivocal light, and Czernin's refusal to accept full responsibility for the Emperor Charles's proceedings led to his resignation, Count Burian being reappointed as his successor. In order to calm the agitation of the Emperor William and the German statesmen and generals, the Emperor Charles had to make another "journey to Canossa" at Spa, and there, on May 12 1918, he set his signature to agreements for a closer political and military union between the two countries, the coming into force of which would have meant heavy damage to the independence of Austria-Hungary. But since the condition of the validity of this treaty, namely an understanding between the two Powers on the Polish question, broke down, the Spa agreement, too, remained a scrap of paper.

Meanwhile Germany was putting forth her last strength in the hope of achieving a decisive success. But her initial successes were followed by reverses. Austria-Hungary had taken part in the battles on the western front, but only within modest limits. In June 1918 she attempted a sudden attack on Italy with the principal body of her troops; but here, too, the decisive victory which had been expected was not achieved. These failures, together with the ever-increasing lack of effective soldiers, arms, munitions and foodstuffs, deepened the longing of the peoples of the Habsburg Monarchy for peace. In addition, the Emperor Charles became alive to the more and more open opposition of the non-German and non-Magyar peoples of his dominions, and likewise to the revolutionary spirit which was becoming conspicuous among the working-classes in many places, and he began to tremble for his crown and the fate of the dynasty. In proportion as the German hope of extorting peace by force of arms diminished, a more favourable prospect seemed to open up for the efforts of Austro-Hungarian statesmen to put an end to the war by way of diplomatic negotiations. At the end of July 1918, Baron Kühlmann, the German Secretary of State for Foreign Affairs, had been compelled to resign in consequence of his saying in the Reichstag that an end of the war through a purely military decision could not be expected. But by Aug. 14 Ludendorff himself, who had played a prominent part in bringing about Kühl-

*Negotiations for  
Peace.*

mann's fall, declared at headquarters in Spa that they could no longer hope to break the military spirit of the foe by force of arms. Thus when Burian again approached the German Government, he no longer met with any opposition on principle. Yet great differences presented themselves in the course of the deliberations as to the course to be adopted. The Germans wanted to wait for an improvement of the military situation in the West and then begin negotiations with the enemy through a neutral Power—Holland or Spain—while Austro-Hungarian statesmen advocated an immediate and open appeal to all the combatant Powers. At the beginning of Sept. 1918 the German Minister Hintze spent some time in Vienna in order to arrive at an agreed course of action. But since this could not be achieved, Burian determined, without regard to Germany's opposition, to have an appeal sent out to all the combatant States for the opening of peace negotiations. President Wilson answered, however, after a few days' interval, that he had repeatedly and in the plainest terms made known the conditions on which he was prepared to consider the conclusion of peace; hence the Government of the United States could not and would not accept a proposal for the holding of a conference concerning a matter in which it had already clearly made known its attitude and aims. And the Cabinets of Paris and London were equally cold. The sole result of Burian's new effort for peace was the increase of the Entente's hopes of victory. On Sept. 15 ensued a violent attack against the Bulgarian army, in the ranks of which war-weariness had for long past made serious inroads. The Bulgarian troops offered but little resistance; great bodies of them laid down their arms, and returned to their homes. The Sofia Government, at the head of which Malinov, who was friendly to the Entente, had for some months taken the place of Radoslavov, resolved to propose an armistice, which was granted on Sept. 29 under conditions which signified for the Central Powers the loss of the Balkans. King Ferdinand abdicated. These events, and the great successes of the English troops in Palestine, produced their effect upon Turkey. At the beginning of October the fall of Enver and Talat took place at Constantinople, and thus the way was opened here too for a separate peace. An armistice was concluded between Turkey and the Entente on Oct. 31 1918, which brought the Dardanelles and the Bosphorus under their power, and pledged the Turks to break off all relations with the Central Powers.

Meanwhile the catastrophe had taken place in Austria-Hungary as well. Encouraged by the repeated pronouncements of President Wilson as to the right of nations to self-determination, the separatist ideas of those peoples of the monarchy which did not acknowledge German or Hungarian nationality became more and more articulate. There were disturbances in various parts of the monarchy, and these disruptive influences made it month by month increasingly difficult to keep the army efficient for war. Both Austria-Hungary and Germany now decided to address to President Wilson the offer of an armistice, to be followed by negotiations for peace. To this offer the President at first made no reply; and thereupon the Emperor Charles, in order to save the dynasty, issued on Oct. 16 a manifesto in which he proclaimed that Austria, in accordance with the will of her peoples, was to be erected into a Federal State, in which every race would be free to establish its own form of body politic on the territory occupied by it. But the union of the Austrian Poles with an independent Polish State was not to be anticipated by this. The imperial manifesto was only to apply to Austria. For Hungary, where they were already working for a personal union and for a complete separation from Austria, the manifesto laid stress upon the integrity of the Hungarian kingdom. It thus became clear to the Southern Slavs that they must no longer hope for a realisation of their national aspirations within the bounds of the monarchy. But the Emperor Charles's expectation of conciliating the opinion of the Austrian Slavs by means of the manifesto met with no success. President Wilson, too, rejected the Vienna Cabinet's peace offer. He declared

*Break-up  
of the  
Monarchy.*

both Austria-Hungary and Germany now decided to address to President Wilson the offer of an armistice, to be followed by negotiations for peace. To this offer the President at first made no reply; and thereupon the Emperor Charles, in order to save the dynasty, issued on Oct. 16 a manifesto in which he proclaimed that Austria, in accordance with the will of her peoples, was to be erected into a Federal State, in which every race would be free to establish its own form of body politic on the territory occupied by it. But the union of the Austrian Poles with an independent Polish State was not to be anticipated by this. The imperial manifesto was only to apply to Austria. For Hungary, where they were already working for a personal union and for a complete separation from Austria, the manifesto laid stress upon the integrity of the Hungarian kingdom. It thus became clear to the Southern Slavs that they must no longer hope for a realisation of their national aspirations within the bounds of the monarchy. But the Emperor Charles's expectation of conciliating the opinion of the Austrian Slavs by means of the manifesto met with no success. President Wilson, too, rejected the Vienna Cabinet's peace offer. He declared

that the Government of the United States had already recognized Czechoslovakia as a belligerent Power and the Czechoslovak National Council as a belligerent Government, as well as the justice of the national aspirations of the Southern Slavs. It was, therefore, for these peoples themselves to decide which of the resolutions of the Austrian Government were acceptable to them. Upon this the request for an armistice made by the Emperor Charles at the beginning of October was declared to be no longer in force. During October independent national representative bodies assembled in Prague, Agram, Laibach and Vienna. The Emperor's dominions thus dissolved and slipped from his grasp. These internal movements led to the disintegration of the armies, which up to this moment had fought bravely. The Governments of the several countries constituting the monarchy, Hungary leading the way, summoned their co-nationals to the defence of their particular frontiers or called them back home. The Emperor Charles tried to save what still could be saved. He was prepared to conclude a separate peace with the enemy on terms which would make possible the continuance of the old monarchy, even though with diminished territory and as a loose aggregation of separate territorial groups under the dynasty of Habsburg-Lorraine.

On Oct. 24 Count Julius Andrássy succeeded Burian as Foreign Minister, in order to begin negotiations for a separate peace. Three days later the office of minister-president was given to Heinrich Lammasch, professor of international law and a well-known pacifist. On the same day renewed proposals for an armistice were made to President Wilson, and the peace *pourparlers*, which had never been entirely interrupted, were resumed in Switzerland with representatives of the Entente by various emissaries of the Habsburg Monarchy. Once more, however, they reached no result. At the end of October, after the revolution in Hungary (see HUNGARY: History), and when increasing numbers of the troops fighting in Italy had started homewards, the Austro-Hungarian army command asked for an armistice from the Italians, who were victoriously advancing against the demoralized and dissolving Austro-Hungarian forces. This was granted on Nov. 3 1918 on conditions of pitiless severity. Austria-Hungary had to reduce her army at once to a peace footing—only 20 divisions were excepted; to evacuate all enemy territories still occupied by her troops; to surrender to the enemy large portions of Austrian territory, and to hand over all war material actually in these territories, as well as the whole of her fleet. By this means all resistance was made impossible even after the expiry of the armistice. Utterly defenceless, the Emperor Charles had to place his own fate and that of the ancient monarchy in the hands of the victors. The latter also demanded free passage for their armies over all roads, railways and waterways of the monarchy. Germany's resistance was thus to be broken by new dangers threatening her from the south. It was only under protest, and bowing to necessity, that the Emperor Charles gave his consent to these demands, which promised to be fatal to his ally. The negotiations for a separate peace were indeed even now still carried on by the diplomatists who remained true to the dynasty, but they hardly met with a hearing from the Entente Powers.

The process of dissolution ran its course in the old monarchy. On Nov. 11 1918 the Emperor Charles renounced all share in the business of government in Austria; the Lammasch Government retired. The Emperor Charles did not, however, renounce his crown. On the following day, in the Austrian National Assembly, a republic was proclaimed (see AUSTRIA, REPUBLIC OF), which was at first intended to form a component part of the new German Republic. On Nov. 16 the republican form of government was introduced in Hungary. The ancient Austro-Hungarian Monarchy had thereby ceased to exist, and its rôle as a European Great Power was at an end.

**BIBLIOGRAPHY.**—Up to 1921 no comprehensive critical account had been published of Austro-Hungarian foreign policy in 1910-8. *The Foreign Policy of Austria-Hungary* (1920), No. 1, of the hand-

books prepared under the direction of the Historical Section of the British Foreign Office, is a summary survey. The period 1875 to 1914 is treated in an inadequate and one-sided way in Jean Larmieux, *La Politique extérieure de l'Autriche-Hongrie* (2 vols., 1918). The foreign policy of the monarchy is discussed in its connexion with world politics in, among other works, A. Debidour, *Histoire diplomatique de l'Europe*, vol. iv. (1918); Ernst Reventlow, *Politische Vorgeschichte des grossen Krieges* (1919); Julius Hasagen, *Umriss der Weltpolitik*, vol. ii. (2nd ed. 1919); Gottlob Egelhaaf, *Geschichte der neuesten Zeit*, vol. ii. (8th ed.) and Heinrich Friedjung, *Das Zeitalter des Imperialismus*, vol. ii. (1922). Friedrich Wieser's study, *Oesterreichs Ende* (1919); and F. Kleinwächter's book, *Der Untergang Oesterreich-Ungarns*, throw more light on the internal disintegration of the Habsburg Monarchy, but also contain interesting discussions of foreign policy. Meisser's *Politische Chronik der Oesterreich-Ungarischen Monarchie* (1910-8) and Schulthe's *Geschichtskalender* (1910-8) contain extracts from the reports of the proceedings of the delegations and the Austrian and Hungarian parliaments and other important documents and speeches. Of the official publications of the Ministry for Foreign Affairs should be mentioned: *Diplomatische Aktenstücke betreffend die Ereignisse am Balkan*, 13. August 1912 bis 6. November 1913 (Vienna 1914); *Diplomatische Aktenstücke betreffend die Besetzung Oesterreich-Ungarns in Italien in der Zeit vom 22. Juli 1914 bis 27. August 1918* (Vienna, 1916); *Diplomatische Aktenstücke zur Vorgeschichte des Krieges: Ergänzungen und Nachträge zum Oesterreich-Ungarischen Rohbuch* (3 parts [June 28-Aug. 27, 1914], Vienna 1920). At the instance of the Ministry for Foreign Affairs there appeared Richard Gooss, *Das Wiener Kabinett und die Entstehung des Weltkrieges* (1919). A. F. Pribram's *Die politischen Geheimverträge Oesterreich-Ungarns 1879 bis 1914* (1920) also contains a detailed history of the development of the Triple Alliance treaties (English trans. by A. C. Coolidge, 1920). Valuable information as to Austro-Hungarian foreign policy is to be found in memoirs of German and Austro-Hungarian statesmen and military commanders which have appeared since the end of the war.—Among these may be especially indicated: G. Jagow, *Ursachen und Ausbruch des Weltkrieges* (1919); Paul von Hindenburg, *Aus meinem Leben* (1920); Theodor von Bethmann-Hollweg, *Betrachtungen zum Weltkrieg* (1919); Erich Ludendorff, *Kriegserinnerungen* (1919); *Urkunden der Obersten Heeresleitung über ihre Tätigkeit 1918 bis 1918* (1920); A. von Tschirpitz, *Erinnerungen* (1918); Karl Helfferich, *Der Weltkrieg* (5 vols., 1919); Karl Helfferich, *Ein Jahr in der Reichskanzlei* (1919); A. von Cramon, *Unser Oesterreich-Ungarischer Bundesgenosse im Weltkrieg* (1920); Ottokar Czernin, *Im Weltkrieg* (1919); Julius Andrássy, *Diplomatie und Weltkrieg* (1920); L. Windschgrätz, *Vom roten zum schwarzen Prinzen* (1920); Auffenberg-Komarow, *Aus Oesterreichs Höhe und Niedergang* (1921); Erich von Falkenhayn, *Die Tätigkeit der Obersten Heeresleitung 1914 bis 1918* (1919); Matthias Erzberger, *Erlebnisse im Weltkrieg* (1920); J. V. Szilassy, *Der Untergang der Donaumonarchie*. (1921). Separate problems of Austro-Hungarian foreign policy are treated among others by Leopold Chlumeczek, *Die Agonie des Dreibundes* (1915); Wilhelm Frankov, *Kritische Studien zur Geschichte des Dreibundes* (1916); Severus, *Zehn Monate italienischer Neutralität* (1915); Th. v. Sosnosky, *Die Balkanpolitik Oesterreich-Ungarns seit 1866* (2 vols., 1914); *Die Politik im Habsburgerreich* (1912); Berthold Molden, *Albis Graf Aehrenthal: Sechszehn Jahre äusserer Politik Oesterreich-Ungarns* (1917). (A. F. Pr.)

**AUSTRIA, REPUBLIC OF.**—The republic of Austria, reconstituted after the collapse in 1918 of the old empire (see AUSTRIAN EMPIRE) is bounded on the E. by Czechoslovakia, Hungary and Yugoslavia, on the S. by Yugoslavia and Italy, on the W. by Switzerland, Liechtenstein and the Lake of Constance, on the N. by Germany (Bavaria) and Czechoslovakia.

Under the new régime, Austria had in Aug. 1921, including the Burgenland (which was in process of being handed over by Hungary), an area of 32,401 sq. m., somewhat less than that of Ireland. Its population is less than one-fifth that of England. It belongs almost entirely to the Danubian region and for the greater part to the Eastern Alps; a small part of it embraces the outlying spurs of this mountain system, which form a connexion with the Carpathians; and another part comprises the Austrian Granite Plateau, the most southerly portion of the Boic massif. But Austria's frontiers, especially towards the Alps, are not natural boundaries, and their long extension is a source of geographical and economic inconvenience. Czechoslovakia received three minor border territories of Lower Austria; Italy advanced as far as the Adriatic watershed, and even passed beyond it in various places in the basins of the Inn and Drau (Drava); Yugoslavia received South-Eastern Carinthia and Southern Styria as far as the Posruck and the Mur. Thus the closed territories of Tirol and those of the Carinthian basin



and Central Styria were cut off; the two great natural triangular routes, that of German Tirol and that within Austria, and hence also the northern longitudinal railway of the Eastern Alps (Franzensfeste-Murburg) were split up between different states (see CARINTHIA, STYRIA, TIROL).

**Population.**—The territories under Austrian administration in May 1920, which alone could be included in the census of Jan. 31 1920, embraced a portion of Lower Austria belonging to Czechoslovakia; on the other hand, electoral district No. 1. of Carinthia and a few communes of Styria were occupied by the Southern Slavs, and the disputed Burgenland (German Western Hungary) by Hungary. With these reservations the figures in the appended table hold good.

Territory	Area in sq. m.	Pop. Dec. 31 1910.	Pop. Jan. 31 1920.	Density persq. m.
Lower Austria	7,639	3,525,094	3,313,155	435
Upper Austria	4,626	853,006	857,234	184
Salzburg	2,762	214,737	213,877	77
Styria	6,304	952,590	946,721	151
Carinthia	3,017	299,091	297,257	99
Tirol	4,787	304,713	306,153	64
Vorarlberg	1,005	145,408	133,033	132
Total	30,140	6,294,639	6,067,430	201
Carinthia, Zone I	667	72,138	—	—
Burgenland	1,684*	345,082*	—	—
Total	32,491*	6,711,859*	—	—

\* Approximate.

The returns show that, in consequence of the war and the shortage of foodstuffs in all countries from 1910-20, the populations of Upper Austria and Tirol decreased greatly during that period (the average decrease was 3.6%). In Vienna, the birth-rate had slightly increased, but in 1921 was still lower than the death-rate. In 1910, the proportion of males and females was as 1,000 to 1,024; in 1920 as 1,000 to 1,089. The nationalities of the inhabitants are not shown in the census of 1920; only the Czechs in Vienna and the Slovenes in Carinthia form important minorities.

The population of the mountainous districts is sparse; only Lower Austria, thanks to Vienna, shows a dense population. Excluding Vienna it would show only 104 inhabitants per sq. m. In the area covered by the census of 1920, 39.8% of the population was in 3,551 communal districts having up to 2,000 inhabitants; 14.1% in 295 such districts having 2,001 to 5,000 inhabitants; 4.8% in 43 districts of 5,001 to 10,000 inhabitants; 2.8% in 13 districts of 10,001 to 20,000 inhabitants; 3.0% in seven districts of 20,001 to 50,000 inhabitants, and 2.5% in two districts of 50,001 to 100,000 inhabitants; 33.0% were, however, in two districts of over 100,000 inhabitants (Vienna and Graz). In 1910 94.12% of the

population was Roman Catholic, 2.6 Evangelical, 2.98 Jewish, other faiths 0.3%.

**Education.**—At the end of 1918 there were 4,102 free public primary schools (*Volkschulen*), with 17,497 teachers and 788,891 pupils; 331 higher elementary middle-class schools (*Bürgerschulen*), with 3,310 teachers and 82,739 pupils; 362 private lower elementary schools with 35,511 pupils; and 69 private higher elementary schools with 6,114 pupils; 1,875 teachers served these private schools. In 1910 the average proportion of persons over 10 years of age who could both read and write was 95.70% (in Vorarlberg 99.12%, in Carinthia 85.43%); 0.80% (in Carinthia 2.28%) could only read and 3.5% could neither read nor write. At the end of 1918 there were 37 institutions for training teachers—16 for men and 21 for women. In addition to the elementary schools there are three groups of higher schools: intermediate schools, professional and technical schools, and "high" schools. There are also higher and lower schools for forestry and agriculture. In 1917-8, 46 of the intermediate schools (*Mittelschulen*) were *Gymnasien* (classical schools), 26 *Realgymnasien*, *Reform Realgymnasien*, etc. (in which Latin is taught); 39 *Realschulen* (modern, without Latin) and 26 *Mädchenschulen* (girls' colleges) with, together, 3,135 teachers and 40,147 pupils. Of the girls' colleges, one ranked as a *Gymnasium* and two as *Realgymnasien*. But girls are required to attend the other intermediate schools; the number of girls' colleges is diminishing. The churches have charge of religious instruction in the elementary and intermediate schools. In 1917-8, there were 9 higher and 32 second-class commercial schools, 19 higher technical schools and 53 special technical schools; and 4 intermediate and 38 lower agricultural and forestry schools.

The higher educational establishments are:—Three universities (Vienna, Graz and Innsbruck), each with four faculties—Catholic theological, law and political sciences, medicine, and philosophy; two technical colleges (Vienna and Graz); the Evangelical theological faculty in Vienna, and that of Catholic theology in Salzburg. There are, also in Vienna the high schools of commerce, agriculture and veterinary science, the consular academy, the academy of plastic arts, the special school for medal and stamp engraving, the academy of music and graphic arts, and at Leoben the college of mining.

**Agriculture and Forestry.**—In the returns according to occupations taken in 1910, it appeared that 40.14% of the population was engaged in agriculture and forestry, 34.81% in manufacture, 17.40% in trade, and 7.65% in other occupations. Not taking Vienna into account, 56.36% was engaged in agriculture and forestry. In 1900, 10.4% of the land was unproductive (in Tirol 23.7%; in Lower Austria 3.7%).

Of the productive areas, 25.6% was arable (in Lower Austria 45.2% and in Vorarlberg 3.4%), 1.7% gardens and vineyards (in Lower Austria 3.5% and in Vorarlberg 0.2%), 12.4% meadow (in Upper Austria 20.1% and in Tirol 7.4%), 17.8% grazing-lands (Vorarlberg 51.3% and Upper Austria 2.7%), 42.5% forest (Styria 54.4% and Vorarlberg 29.4%). The high Alpine lands of Vorarlberg, Tirol and Salzburg are characterized by the smallness of their total

cultivated area and their large expanse of pasturage, and the country of the Danube valley by its large area of arable and small amount of meadow-land. The territories of Styria and Carinthia have an intermediate character, being mostly thickly wooded.

The chief crops are rye, oats, barley, potatoes, maize, pulse, turnips and flax; but the supply falls far short of the demand. In 1913 3.5% of the arable land lay fallow, and in 1918 no less than 17.5%. Fruit-growing is wide-spread, but vine-culture has attained importance in Lower Austria only. The timber output, on the other hand, is very important; the forests in 1910 covering 11,912 sq. m., of which 8,576 were covered with pine forest and 926 with deciduous trees only. Stock-raising is important in many districts, but in 1921 by no means met demands. Excellent breeds of cattle are reared in Vorarlberg (Montafon breed), Tirol (Tuxental, Pusterthal, etc., breeds), Carinthia and Styria (Noric Alpine breed). In 1918, there were 1,841,883 head of cattle (of which 907,894 were milk-cows) and 1,269,875 swine. Good breeds of horses are raised, especially in Salzburg (Pinzgau breed), but the total number scarcely reached 200,000. There were some 300,000 sheep and a slightly smaller number of goats. Poultry abounds (some six million head in 1918). Bee-culture thrives in Carinthia and Styria in combination with the cultivation of buckwheat.

**Minerals.**—The mining output of 1915 included some 75,000 tons of coal (almost all from Lower Austria), 2.4 million tons of brown coal (1.8 from Styria), 1.8 million tons of iron ore (almost all from Styria), 17,000 tons of copper ore (almost all from Salzburg), 22,500 tons of lead ore (almost all from Carinthia), 14,000 tons of graphite (almost all from Styria), considerable quantities of magnesite (from Styria and Lower Austria), some sulphur and ores of zinc and antimony, and (from Styria) bitumen. The output of salt was 160,000 tons; of which 100,000 tons were produced in Upper Austria, the remainder in Styria, Salzburg and Tirol. Natural gas is obtained at Wels in Upper Austria.

The most important mines are:—The iron mines in the Styrian Erzberg (Eisenerz and Vordernberg) and those of Hüttenberg in Carinthia; the copper mines of Mitterberg in Salzburg; the lead mines of Bleiberg in Carinthia; and the brown-coal mines of Köflach and Voitsberg, Wies and Eibiswald, Fohsford and Loeben, in Styria, Wolfsberg in Upper Austria. The salt mines have already been mentioned. The smelting industries produced 900,000 tons of pig iron (almost exclusively in Styria), some 5,000 tons of copper (in Salzburg), about 8,000 tons of lead (in Carinthia), besides copper sulphate, mineral colours, a little silver and a very little gold. The output decreased after 1915 but was recovering in 1921. With the exception of iron ore and magnesite, the minerals do not suffice to meet the needs of Austria herself; she can only supply one-seventh part of the coal she requires.

**Manufactures.**—The industries of Vienna are very varied. Industrial areas of the first rank are:—Lower Austria, Vorarlberg and Upper Styria; next to them come Upper Austria and Middle Styria. The largest iron works are in Styria (Eisenerz, Vordernberg, Hieflau, Donawitz, Zeltweg, Kapfenberg, Müritzschlag); in Lower Austria (Waidhofen an der Ybbs); in Upper Austria (Linz, Wels). There are also machine factories in the above territories, especially in the neighbourhood of Vienna. Iron smallware, such as scythes and sickles, is chiefly made in the districts along the border between Upper and Lower Austria and Styria; Steyr is an important centre. Locomotives are made in Vienna, Wiener Neustadt, Graz and elsewhere; small arms in Steyr, Vienna and Ferlach; carriages and automobiles in Vienna and Graz; bicycles at Steyr and Graz; river boats at Linz. Lower Austria (Berndorf and elsewhere) is noted for the manufacture of base metal goods. Carinthia produces leaden articles.

The cotton and woollen industries are important, especially in the Vienna district, Vorarlberg and near Linz and Graz. Important, also, are the jute industry of Lower Austria and the manufactures of machine-made knitted goods in Vorarlberg. The coarser kinds of woollen cloth are made in Tirol and Vorarlberg; clothing, silk goods and articles of luxury of all kinds are made in Vienna, hats in Vienna and Graz. Vienna is also noted for the manufacture of furniture. The wood, cellulose, pasteboard and paper, and paper-goods industries of Lower Austria, Styria and Upper Austria are very important. Leather and leather goods are chiefly produced in Lower Austria; shoes and gloves in Vienna. The Vienna district and the foot-hills of the Alps are flour-milling centres, while distilling and malting are chiefly carried out in Vienna. The chemical industry is notably active in Vienna and its neighbourhood; also the manufacture of colours and varnishes. The manufacture of explosives is centred in Middle Styria (Deutsch-Landsberg), and there are chemical works in the Alps, when water-power is available. The pottery and glass-making industries are also noteworthy. Vienna is the chief centre of printing and the graphic arts, and of artistic trades generally.

The manufacture of tobacco is a State monopoly (there are factories in Vienna, Hainburg, Fürstenfeld and other places). (R. St.)

#### CONSTITUTION AND ADMINISTRATION

The collapse of the Austrian Empire in the autumn of 1918 was an event which all nationalities living within its frontiers

anticipated. They were thus prepared, sooner or later, to set themselves up as independent states. Serious resistance was not to be expected, as the military *débâcle* had been so complete as to prevent any possibility of stopping the process of disintegration. A premonitory symptom had been the Imperial Manifesto of Oct. 16 1918, in which the Emperor Charles announced his resolve, in accordance with the wish of his peoples, to transform Austria into a Federal State in which every nationality was to form a separate state-entity within its own ethnographical limits. Not many years previously such a manifesto might have initiated a happy development by which the World War would have been avoided and Austria perhaps been consolidated. But now it was too late, and the manifesto was thus no more than a signal given in the highest quarters of the approaching general dissolution.

Independently of the Imperial Manifesto, and by a procedure purely revolutionary, the German members of the former Austrian Reichsrat, on Oct. 21 1918, established themselves as the Provisional National Assembly of German-Austria, and as such established the new state of "German-Austria," for which a provisional constitution was adopted on Oct. 30. The new constitution, which was republican, was carried at once, and without the least resistance being encountered, though it was not till Nov. 11 that the Emperor Charles issued a proclamation, countersigned by his last prime minister, Lammasch, in which he declared himself ready to acknowledge beforehand whatever decision German-Austria might come to concerning her future constitution, and renounced all share in affairs of State. The revolution out of which the new German-Austria emerged was thus not only bloodless, but was carried through without any open struggle. It was, none the less, a revolution; for the constitution of German-Austria was not evolved by any legal process out of the constitution of old Austria. Between the two lies the break in the continuity of constitutional practice, and it is for this reason that German-Austria cannot, any more than Czechoslovakia, be looked upon as identical with the old Austria.

**The Provisional Constitution.**—The first provisional constitution of German-Austria, created by the resolution of Oct. 30 1918 and supplemented by several later laws (above all, that of Nov. 14 1918 on the taking-over of State authority in the Territories, and that of Nov. 19 1918), exhibits an extreme type of democratic parliamentary government. The supreme power in the State, executive as well as legislative, was conferred upon the Provisional National Assembly. This exercised its legislative power directly through its enactments. Its executive power, however, was exercised through a Council of State (*Staatsrat*) elected from among its members, the three parliamentary parties—Christian Socialists, Social Democrats and German Nationalists—being proportionally represented. The Council of State thus formed a parliamentary committee which functioned as a sort of head of the State.

In contradistinction to the old Austrian Reichsrat, with its Upper and Lower House, the first legislative body of German-Austria was organized on the single-chamber system. Each of the three parties elected a president to act as speaker of the parliament. These three presidents were coequal and occupied the chair week by week in an agreed rotation.

The legislative power of the Provisional National Assembly was restricted, in that legislation on certain matters, which under the old system appertained to the autonomy of the so-called Crown Territories (*Kronländer*) of the Austrian Empire, was reserved for the Provisional Territorial Assemblies, which had taken the place of the former Territorial Diets (*Landtage*) in which the functions of self-government had been vested. For these, under the style of "Territories" (*Länder*), remained within their old frontiers—though, of course, only to the extent in which they formed part of the new State: viz. Lower and Upper Austria, Salzburg and Vorarlberg, in their entirety; Styria and Carinthia, with the exception of areas inhabited by Yugoslavs; Tirol, without its southern part mainly inhabited by Italians. Out of the former "crown lands," Bohemia,

Moravia and Silesia, which were inhabited by about 3½ million Germans, two new Territories were carved: German-Bohemia and Sudetenland, each with a Provisional Territorial Assembly. In actual practice, however, the executive power of German-Austria could not extend to these Territories, as they were held by the Czechoslovak State, to which they were eventually assigned. As the revolutionary constitution of the Territorial Assemblies and of the Territories themselves took place at the same time as that of the National Assembly and of the State, but independently, the limits between Territorial legislation and State legislation were not clearly defined from the very outset. The Territories became the centres of a movement in favour of an extreme form of federalism, and this led to the constitution of Austria being ultimately that of a Federal State.

A State law required essentially only a resolution of the National Assembly, which had to be registered and attested by the Council of State and published in the Government law gazette.

The Council of State had a suspensive veto on legislation, but this was overridden by the simple passage of a measure a second time through the National Assembly, a bill then passed at once becoming law. According to the constitution a Territorial law to be valid required not only to be passed by the Territorial Diet but to receive the assent of the Council of State, which, in this as in other respects, had taken the place occupied by the Emperor under the old Austrian constitution. In view of the actual power of the Territories, however, the Council of State was unable to assert its right of veto.

Apart from the 20 delegates, and an equal number of substitutes, elected as already described, the Council of State included the three presidents of the National Assembly, who presided over it in rotation. Though the Council, thus constituted, was the supreme organ of parliamentary Government, it did not itself carry on the administration directly, but through a Cabinet, nominated by it, consisting of so-called secretaries of State, who acted as heads of departments. The Cabinet was also to be presided over by the presidents of the National Assembly in rotation, and it was only in the absence of these that the State Chancellor, whose functions were in fact those of minister-president, took the chair. The Cabinet was subject to the principle of ministerial responsibility, which could be enforced in the special court for dealing with infringements of the laws and constitution (*Staatsgerichtshof*), the functions of which had originally been transferred to a parliamentary committee of twenty.

The whole machinery of administration was taken over from the old Austria almost without a change. Only in the case of the offices forming an intermediate link between the administrations of the Territories and the State was there any drastic reform. Each one of the so-called "Crown Territories" (*Kronländer*), of which the Austrian monarchy was composed, constituted the area of an intermediate administration, at the head of which was a governor or lieutenant (*Statthalter*) nominated by the Emperor and subordinate to the central Government. Side by side with this, however, the Territories existed as autonomous bodies politic, with an administrative system of their own in all matters not falling within the province of the central administration. This autonomous administration was exercised by the Territorial Diet (*Landtag*) through a Territorial Committee (*Landesausschuss*) elected from among its members and presided over by the president of the Diet, who was nominated by the Emperor.

This parallelism of the autonomous and State administrations in the Territories, with the rivalry between them, had been one of the worst evils of the old monarchy; it was done away with under the provisional constitution of German-Austria by the simultaneous democratization of the intermediate administrative system. The whole administration in the Territories was declared to be a State concern; the autonomous and State administrative organizations were amalgamated and subordinated to a Territorial Government, consisting of the head of the Territory (*Landeshauptmann*) and several substitutes

elected by the Territorial Assembly from among its own members. This Territorial Government was subordinated to the central State Government in all matters of Territorial administration, but there were no legal provisions for making this subordination effective. The central State Government could not depose a Territorial Government, nor could it in any way call it to account for disobedience; it was, in short, wholly dependent on the goodwill of the Territorial Government, which, since it was elected by the Territorial Diet, felt itself politically responsible to this alone. This led to a very serious loosening, almost indeed to the complete dissolution, of the administrative system of the State, and was one of the factors which ultimately led to the adoption of the Federal constitution.

As regards the organization of justice and the relations of the citizen to the State, the new provisional constitution confined itself to adopting, more or less unaltered, the respective rules of the old Austrian constitution. In the same way all the remaining private and public law of the monarchy, in so far as it was not inconsistent with the new constitution, was expressly taken over under an article of the provisional constitution, and thus, formally at least, given a fresh validity.

The main task of the Provisional National Assembly, in addition to the creation of a provisional constitution, was to prepare the way for the Constituent Assembly, for which the framing of a definitive constitution was reserved. According to the electoral law passed by the Provisional Assembly, the Constituent Assembly was to consist of 225 members, who were to be elected in 38 constituencies on the basis of equal, secret and personal suffrage for all citizens at least 20 years of age, without distinction of sex, and on the system of proportional representation. Actually, however, only 170 members were returned, as no elections could be held in the territories occupied by Czechoslovakia, Italy and Yugoslavia. Of the 170 deputies, 72 were Social Democrats, 69 Christian Socialists, 26 German Nationalists, the three remaining being a Bourgeois-Democrat, a Czechoslovak, and a Jewish Nationalist (the two latter having supporters in Vienna only).

*The Constituent Assembly.*—The Constituent National Assembly met at Vienna on March 4 1919. Before settling the definitive constitution it made one or two not unimportant modifications in the provisional constitution (laws of March 4 on Popular Representation and the State Government). Above all, the relation between State and Territorial legislation was regulated. In the first place it was decided that all legislative acts of the Territorial Diets were to be submitted to the central State Government, to which was assigned the power of suspensive veto and, in the event of such acts being contrary to the constitution, the right to challenge them before the court established to try constitutional cases (*Verfassungsgerichtshof*). Acts of the Territorial Diet needing the co-operation of the central Government for their execution were made subject to the endorsement of the latter. Drastic alterations were made in the organization of the executive power. The Council of State, with its directory, was abolished, and its governmental and executive powers transferred to the Cabinet, which was henceforth to be directly elected by the National Assembly. The election of the Cabinet was entrusted to the Principal Committee (*Hauptausschuss*), itself elected from the body of the Parliament, the three chief parties being proportionally represented. This Committee, through which Parliament exercised a decisive influence over the executive and without whose consent no important act of Government could be undertaken, to a certain extent took the place of the Council of State, but, unlike this, without any public appearance of functioning as the head of the State. These functions—representation of the State in its relation with foreign Powers, more especially the ratification of treaties, the nomination of officials, the right of pardon, etc.—were entrusted to the president of the National Assembly; so that in this way, too, the character of parliamentary Government found outward expression.

The conclusion of the Treaty of St. Germain compelled a further alteration of the constitution of German-Austria. By



the law of Oct. 1 1919 (on the form of the State) the frontiers of the State were legally defined in accordance with the provisions of the treaty, i.e. the Territories assigned to the other "succession states" were cut off. In these Territories there lived, in a solid group, nearly half as many Germans as the treaty had left to German-Austria, now sadly diminished. The name of the State, which had hitherto been German-Austria (*Deutsch-Österreich*), was legally altered to "the Republic of Austria" (*Republik Oesterreich*), for it was only under this name that German-Austria could obtain international recognition. The sentence "German-Austria is a constituent part of the German Reich," which had hitherto been embodied in the constitution but had represented an aspiration rather than a fact, was now excised, in accordance with Art. 88 of the Treaty of St. Germain, which decreed the "independence" of German-Austria.

Of the remaining provisions of the treaty affecting the constitution of German-Austria, attention need only be called to those dealing with the protection of minorities, which did not, however, add anything essential to the safeguards for nationality and creed secured by the old Austrian fundamental law of Dec. 21 1867 on the general rights of citizens of the State, which had been adopted in the German-Austrian constitution.

*The Federal Constitution.*—It was only under the greatest possible political difficulties that the Constituent Assembly could be brought to fulfil its proper function, that of framing a definitive constitution. From the very first the Federal character of this constitution was above all determined by the fact that this was the only possible way of overcoming the ever-increasing tension between the Territories and the State as a whole. Moreover, the provisional constitution had already contained certain Federal elements, and these had now to be developed in order to give the Territories, constitutionally as well as in fact, the position which they claimed.

From the point of view of technical organization a Federal State may exhibit one of two types of character. In one the legislative and executive power may be divided between a central legislature and executive, whose activity constitutionally covers the whole State, and a number of local legislatures and executives, with jurisdiction over territorial subdivisions of the State, which are known as subordinate states. In the other, the legislatures and executives of the subordinate states may share the legislative and executive powers of the organs of the central State. The first of these types was already exhibited in the provisional constitution of German-Austria. To make the constitution of the Federal State complete, the Austrian Republic really only needed to give the subordinate states, i.e. the so-called Territories (*Länder*), a share in the legislative and executive powers of the central organs of the federation or super-state. The federal constitution created by the law of Oct. 1 1920, however, was not confined to completing the provisional constitution by adding provisions to this effect; it was an effort at a complete reconstruction of the State, in which an attempt was made to balance the strengthening of the federalistic elements by an equivalent elaboration of a centralized legal jurisdiction over legislative and executive acts.

The division of legislative and executive functions between the super-state, known as the Federation (*Bund*), and the subordinate states, known as Territories (*Länder*), resulted in the classification of affairs into four groups. With regard to the first group, which embraced the most important functions of the State—e.g. civil and criminal law, jurisdiction, foreign relations, etc.—legislative and executive powers are reserved wholly to the Federation, the Territories being completely excluded. In the case of the second group, the Federation alone has the power to make laws, but their execution is the affair of the Territories. In the case of the third group, the Federation has the power of legislation in so far as it may lay down general principles, but it is for the Territories to give these principles practical effect in laws and to see to their execution. All matters which do not fall under one or other of these groups constitute the fourth group, which is wholly within the legislative and executive province of the Territories.

The legislative organ of the Federation is the National Council (*Nationalrat*), of which the composition is the same as that of the National Assembly under the provisional constitution, and the Federal Council (*Bundesrat*). In the Federal Council the individual Territories are represented in proportion to the number of citizens customarily domiciled in them, a principle differing from that of Switzerland and the United States, where, in the *Stateshouses* and Senate respectively, the subordinate states have an equal voice whatever their size, but approximating to the constitution of the German Reich, under which the subordinate states were from the first represented in the *Bundesrat*, as later in the *Reichsrat*, according to their size. According to the Austrian constitution, however, the representation of the Territories in the *Bundesrat* is by no means strictly proportional. The largest Territory sends 12 representatives, the rest in proportion to the number of their citizens; but no Territory sends less than three representatives, although the three smallest Territories—Tirol, Salzburg and Carinthia—would not be entitled to so many were the principle of proportional representation strictly carried out. In order to correct the disproportion between Lower Austria, with its population of some 3,000,000, and the smaller Territories, whose population does not exceed 240,000 and 400,000, the Territory of Lower Austria was divided into two parts—the Federal capital, Vienna, and the Territory of Lower Austria. Vienna, with its 1,800,000 inhabitants, is the largest subordinate state.

As the Federal Council is fundamentally concerned only with legislation, and only in very exceptional cases with executive affairs, its members are deputed not by the Governments of the Territories but by the legislative bodies, which are again styled *Landtage* (Territorial Diets), and they are elected on the system of proportional representation. As a legislative organ the Federal Council is in no way placed on an equality with the National Council; it has a suspensive veto, but if the National Council again passes a bill thus vetoed, it becomes law *ipso facto*. A further alteration of the legislative machinery established by the provisional constitution was the introduction of the constitutional referendum and of the right of popular initiative.

The executive power of the Federation is exercised by the Federal Government, whose members are called Federal ministers and meet under the presidency of the Federal chancellor or vice-chancellor; they are assisted in their several departments by secretaries of State. The Cabinet is composed in the same way as under the provisional constitution—election by the National Council on the recommendation of the Principal Committee. An important alteration in the provisional constitution was that the executive functions hitherto assigned to the president of the National Assembly were transferred to a special head of the State, the Federal president, elected for one year by the National Council and Federal Council meeting in joint session under the name of Federal Assembly. To this Federal Assembly the president is responsible.

The executive powers of the Federation are exercised in the Territories by Federal organs subordinated to the Federal Government, or, as a general rule, by the organs of the Territorial Government in the sphere of activity devolved upon them. In the latter case the Territories function as organs of the Federation and are subordinate to it. For this reason the Federation is interested in the constitutions of the Territories, and the Federal constitution therefore contains far-reaching provisions as to the organization of the Territories, and it is only within the limits of these provisions that the Territories are free to settle their own constitutions. So far as their legislatures are concerned, the Federal constitution prescribes the single-chamber system for the Diets, as now established, and their election on the same franchise basis as the National Council. The Territorial Government is to be elected by the Diet, and is to consist of the *Landeshauptmann* and a number of other members. In respect of the spheres of Federal activity assigned to the Territories by devolution from the Federal Government—that is to say, those in which the Territories act as the organs of this Government—it is the *Landeshauptmann* and his subordinates



who are alone concerned. In such cases the ultimate administrative authority is held to lie with the Federal Government, to which the *Landeshauptmann* is responsible. The Federal Government is now in a position to enforce this responsibility by prosecution in the court established to try constitutional offences (*Verfassungsgerichtshof*). The Federal Government also has an influence on legislation in the Territories. It is true that it can only exercise a suspensive veto over enactments of the Territorial Diets, which have all to be submitted to it; but in cases where Federal coöperation is needed in the execution of such enactments, these may not be made public without its consent. In the case of enactments, already published, which are contrary to the constitution the Federal Government has in reserve the possibility of challenging them in the Constitutional Court.

The weightiest influence of the Federal constitution is exercised through the special courts of law established under it to decide cases of alleged violation of the constitution in matters of administration or legislation. Anyone whose rights have been violated by an illegal decision or act of the Federal or Territorial authorities, and who has failed to obtain redress through the ordinary administrative channels, can appeal to the court for the trial of administrative cases (*Verwaltungsgerichtshof*). This court has power to pronounce on the legality of such decisions or acts, and in certain circumstances to amend them. The members of the court, like all the Federal organs, are nominated by the president on the recommendation of the Federal Government, but this recommendation needs, in respect of half the members, the consent of the Principal Committee of the National Council and, in respect of the other half, that of the Federal Council.

The second court administering public law is the Constitutional Court (*Verfassungsgerichtshof*). Of this the president and vice-president, as well as half the members, are elected by the National Council, the other half by the Federal Council. Its primary function is to decide disputes between authorities as to their competence. As the State Court it furthermore hears charges brought by the National Council against Federal ministers, by the Federal Assembly against the Federal president, by the Diets against members of the Territorial Governments. As a court of ordinance (*Verordnungsgerichtshof*) it judges cases of illegal decrees appealed at the instance of the Federal courts or of those of the Territories. Lastly, as a constitutional court in the narrowest sense, it decides, at the instance of the Federal or the Territorial Governments, whether Federal or Territorial laws are or are not constitutional. It has the right to quash an illegal decree or an unconstitutional law. The Constitutional Court also acts as the central court for hearing petitions against elections to all bodies elected by the general vote. It also judges in cases of violation of international law.

The law of the Federal constitution of Oct. 1 1920 did not complete the new structure of the Austrian constitution. Several special laws were still needed, aiming more especially at the reform of the administration both in the Federation and in the Territories. It was hoped that, in the spirit of democratic self-government, this administrative reform would follow the lines of local government in England.

*Authorities.*—See Kelsen, *Die Verfassungsgesetze der Republik Österreich* (1919), and *Die Verfassung Deutschlands* (*Jahrbuch des öffentlichen Rechts*, vol. 9, 1920); Merkl, *Die Verfassung der Republik Deutschösterreich* (*Zeitschrift für öffentliches Recht*, vols. 1 and 2, 1920). (H. K.)

*Finance and Banking.*—When in the last days of Oct. 1918 the various parts of the Austro-Hungarian monarchy constituted themselves on one side independent states (the Austrian Republic, the Czechoslovakian Republic, Hungary, and the republic of West-Ukraine), and for the other part decided on joining already established nations (Italy, Rumania, Yugoslavia), or joined territories detached from other states and forming new states (Poland), there existed in all these territories one uniform paper currency in circulation, i.e. the notes of the Austro-Hungarian Bank, enjoying a fixed rate. It

was clear that such conditions could not be maintained for any length of time, and that, in view of the connexion between paper money of fixed rate and State finance, it was impossible to continue this unity of currency. All the states concerned, which succeeded the Austro-Hungarian Monarchy, were in such financial straits that they considered the continued recourse to the issue of notes a necessity. The note-printing press, however, was in Vienna, and the Austro-Hungarian Bank was actually under the deciding influence of the new German-Austrian Government. It was urgently necessary for the new states to obtain an independent currency, i.e. to make themselves independent, so far as the printing of notes was concerned, of the Vienna note-printing press. This was comparatively easy for those who had joined already existing states, but more difficult for the newly formed states which were obliged in the first instance to create a new currency. In these conditions the money problem, at the moment of the dissolution of the Austro-Hungarian Monarchy, was merely a technical problem of printing; and the question how to obtain printing-plates, banknote-paper and printing-ink appeared for the moment the most important points of currency policy. After the Italian Government as early as Nov. 1918 and the Rumanian Government in Feb. 1919 had made the necessary preparations to substitute respectively the *lira* and the *lei* for the Austro-Hungarian "*krona*," in the territories occupied by them, the Government of the Serbo-Croatian-Slovenian State proceeded in Jan. 1919 to mark the Austro-Hungarian notes circulating within their territory by stamping them. On Feb. 25 1919 the Czechoslovakian Government followed suit by stamping the *kronen* notes circulating in their country. Then the Austrian Government could not remain idle. It could not wait until all the other states had passed from the Austro-Hungarian *krona* to a national *krona*. It had to get rid of the Austro-Hungarian *krona*, in order to avoid the danger of such notes as for one reason or another had not been stamped by the other states returning to German-Austria and thence increasing the inflation. The *kronen* notes circulating in German-Austria were therefore also specially marked, and, by a regulation of March 25 1919 having the force of law, it was decreed that all notes not so marked would not be legal tender within the German-Austrian State.

A decree of Feb. 27 1919 had ordered the stamping over of all notes of the Austro-Hungarian Bank circulating within the territory of the German-Austrian Republic, with the exception of the notes for one and two *kronen* (which also subsequently were ordered to be stamped). With the execution of this regulation the German-Austrian currency was separated from that of the other "succession states," and there was only one special *kronen* note, which was stamped as recognized legal tender for Austria.

The German-Austrian Republic also used the note-printing press as its chief expedient for covering the national expenses. At the time of the carrying-out of the stamping process, at the end of June 1919, the stamped German-Austrian notes in circulation amounted to 7.6 milliards of *kronen*; at the end of 1920 the circulation had risen to 30 milliards. In consequence there was a further depreciation in the exchange. On Dec. 31 1920 the dollar was quoted in Vienna at 668 *kronen*, as compared to 5 *kronen* in pre-war times.

The republic of Austria at first not only maintained the system of restricting exchange operations, introduced under the Empire during the war, but even made it more severe. Only in the summer of 1920 was any relaxation permitted, in so far as the forced release of foreign currencies obtained for goods exported was generally cancelled. In Nov. 1920 further modifications were made, so that by the end of 1920 the only restriction of money transactions with foreign countries remaining in force was the prohibition to import or export *kronen* notes. The regular exchange operations on the Vienna Bourse were, however, not revived. They were replaced by a system of restricted exchange business under the special supervision of the still existing *Devisenkontrolle*.

The general political conditions and the depreciation of money had led to such an *impasse* that up to 1922 the whole financial

system of the republic was in a state of uncertainty. On the one hand, the Austrian State, by the peace treaty of St. Germain, was made liable toward foreign countries for an amount not specifically determined. On the other, it was found necessary for political reasons to introduce a system of providing the population with cheap victuals. As these had to be obtained almost exclusively against payment in foreign currency abroad, and it was desired to sell at home at the lowest possible prices, there resulted a considerable discrepancy between the expenses necessitated by this part of the State budget and the income derived. At the beginning of 1921 the deficit of the Austrian budget was estimated at hardly less than 50 milliards of *crowns* per annum. To cover this deficit the Austrian State, with the help of the Allied Powers, contracted loans abroad, and for the rest relied on the note-printing press. Only a small part of the expenses of the State could be covered by taxation, notwithstanding that all direct taxes were greatly increased and a new direct tax, an extraordinary property tax, was specially introduced in 1920. Of this property tax, the fixing of which required enormous preparation, it was permitted to make prepayments in Feb. 1920 under specially favourable conditions. Such prepayments brought in over 7 milliards of *crowns*, but more than half of these prepayments were made in war loan. The situation of the Austrian State budget was therefore in 1921 a most unfavourable one. An improvement could only be expected on the one hand by doing away with the system, which could not be permanently maintained, of providing necessaries for the population below cost price at the expense of the State, and on the other by a radical reform of the many State and municipal enterprises (post, telegraph, telephone, State railways, salt-mines, tobacco manufactories, town railways, illumination and power works).

(L. V. M.)

### HISTORY

When in Oct. 1918 the break-up of Austria-Hungary became a matter of common knowledge (*see* AUSTRIAN EMPIRE), the Germans of Austria also announced their right to self-determination. The impulse towards this movement came from the left wing of the Social Democrats who occupied the same standpoint as the Independent Socialists of the German Reich. They had long opposed the view that the dissolution of the Habsburg Monarchy, which was not highly industrialized, and the annexation to a strongly socialistic Germany of the Austrian territories with a German population (the Alpine territories, German Bohemia, and the Sudetic territories), which would thereby be rendered possible, must necessarily involve a proletarian policy; and their views now completely gained the upper hand over the Great Austrian tendencies within the party. The "provisional National Assembly" of German-Austria at its first session (Oct. 21 1918) did indeed regard its connexion with the other national states of the old empire as not yet fully dissolved. But only nine days later (Oct. 30 1918) the new State was constituted in the fullest independence of the dynasty and of its former companion states speaking other languages. The last impulse towards this radical procedure had been given by Andrassy's overtures for a separate peace, which were regarded in wide circles in German-Austria as a betrayal by the Emperor of the German people, and gave rise to revolutionary demonstrations in Vienna. Under the influence of subsequent events in Germany the Emperor Charles was compelled to renounce, on Nov. 11 1918, the exercise of governmental functions, and henceforward to recognize whatever form of government the people might choose. The day after, under pressure from the Social Democrats, the republic was proclaimed.

In the new free State all three parties—the Christian Socialists, German National party, and Social Democrats—formally assumed a share of the responsibility of government. Thus from the outset power had passed almost entirely into the hands of the Social Democrats. The bourgeois parties acquiesced all the more willingly in this, since they were of opinion that only the Labour party would be able to conjure away the dangers which threatened from the break-up of the old army and of the old

authorities. The Social Democrats piloted the State skillfully through the first great vicissitude, though naturally in accordance with their own point of view. Above all, in order to check any reactionary tendencies, they disbanded all bodies of troops belonging to the old army on their hands from the front, and placed the newly formed militia (*Volkswehr*), manned by the proletarian classes, under the leadership of councils of soldiers who were faithfully devoted to them.

But the very first two months cost the young republic serious losses of the territorial possessions which they had claimed on the basis of the "right of self-determination." The Czechs occupied not only all the Sudetic territories populated by Germans, but also a few strips of land on the borders of Lower Austria. The Yugoslavs, going beyond the Slovene territories of Southern Styria, stretched out their hands towards the purely German towns of Marburg and Radkersburg. The repeated attempts which they made early in 1919 to gain a footing also in German portions of Carinthia were repulsed by the inhabitants, accustomed as they were to war. From the beginning of the Armistice German Southern Tirol—with Bozen and Merano—found itself in Italian hands.

The "Constituent Assembly" was elected under the influence of the terrible economic consequences of the war and of the break-up of the monarchy. The Social Democrats won a "relative" majority, with 72 seats out of 170. They formed a coalition for purposes of government with the second strongest party, the Christian Socialists, who represented the peasant and lower middle-class elements. At the head of the Cabinet was the State Chancellor, Dr. Karl Renner, who had already directed the Government since the revolution. The secretariats of State, which were of more political importance, were likewise occupied by Social Democrats, who also set the pace in other departments. Otto Bauer, who was followed in the Ministry for Foreign Affairs as early as 1918 by Victor Adler, strove with all his strength for a union of German-Austria with the German Reich, in which endeavours he was supported by all but a section of the Christian Socialists. The preliminary negotiations conducted with Berlin early in 1919 met with a favourable result. Bauer counted very much in his plans upon the support of the Italians, to whom the Austrian policy of union might be welcome for a variety of reasons. As to internal policy, the object was to make the republican form of government lastingly secure. The National Assembly set aside the dynasty of Habsburg-Lorraine, banished its members from the country if they did not submit entirely to the laws of the republic, confiscated a great part of its family domains, and abolished the nobility. The leading party was particularly zealous in introducing numerous laws of a socialist nature, of which the early part of 1919 was especially productive.

The alarming conditions of Austria came daily more darkly into view. Famine and misery forced the State straight into the abyss of serious social shocks. Soldiers and civilians, professionals and amateurs, seized at the means of self-protection. The several Territories (*Länder*), in all of whose Diets—with the exception of Lower Austria—Christian Socialist majorities had been sitting since the elections in the summer of 1919, put up political and economic barriers against each other, and sealed themselves off even more hermetically from Vienna. Both in town and country party organizations of every sort interfered in administration—generally with the best intentions—and this resulted not infrequently in attacks on the freedom and property of their fellow citizens. The State Government was meanwhile powerless. The events in Budapest and Munich, where, in March and April 1919 respectively, Soviet republics had been set up, prompted to action the small Austrian Communist party, which had seceded from the Socialists of the Radical Left during the days of the revolution. In Vienna, on Easter Thursday and on June 6 1919, excesses were committed in consequence of the plots of native and foreign Communists, which led on both occasions to loss of life. If more serious consequences were avoided, this was as much due to the admirable police of Vienna as to the quiet and reasonable attitude of the Socialist leaders,

who were conscious of their responsibility, and the good temper of the German-Austrian populace. When it became clear that the Communist disturbances were to no small extent fomented by the Hungarian Mission in Austria, dissensions arose between Vienna and Budapest, which were not settled till the Hungarian Soviets replaced their envoy, who had been involved in the affair, by a *persona grata*.

On May 12 1919 the State Chancellor, Dr Renner, had gone with a delegation to St. Germain-en-Laye to receive the terms of the dictated peace. With the exception of the Magyars, all the countries formerly under the same Government as the German-Austrians had "associated" themselves with their enemies in the World War. It was in no small degree due to their counsels that the Treaty of Peace turned out to be even more severe than that with Germany. In comparison with the loss of former German territory and of 3,000,000 German-Austrian subjects, combined with unprecedentedly heavy economic burdens and restrictions, the acquisition of the Burgenland (German Western Hungary) and the promise of the Entente to assist in the reconstruction of Austria seemed but poor advantages, the value of which remained to be proved.

Otto Bauer recognized in the provisions of Article 88, which specifically forbade Austria's union with Germany, and in the fact that Italy, in spite of the Italophil attitude of the Vienna Cabinet, annexed German Southern Tirol for good, a complete defeat for his policy; and he resigned. Renner took over in person the charge of foreign affairs. The Treaty of St. Germain was signed on Sept. 20 1919, with a few small modifications of the original draft; on Oct. 17 it was approved by the Constituent Assembly; and in July 1920 it came into force. By his open adhesion to "Westernism" and the policy of the League of Nations, Renner made known Austria's honourable intention of taking her stand entirely on the basis of the Peace Treaty, in which case she hoped for help from the Entente in her destitution, which had been made even deeper by the operation of the Treaty. In Dec. 1919 the Chancellor found an opportunity of making personal representations in Paris as to the sufferings of his country, in Feb. 1920 other Austrian statesmen were in a position to do the same. Indeed, on more than one occasion Austria received temporary assistance. Moreover, the general right of the Entente to a mortgage on all Austria's assets, provided for in the Peace Treaty, was so far limited as to facilitate the acquisition from abroad of those commodities which were most pressingly necessary for the moment. A special "Austrian Section of the Reparations Commission" was appointed to study the measures most necessary for a lasting cure for the ills of the body politic, and met in Vienna on April 17 1920 under the presidency of Sir William Goode. The international commissions which were to supervise the disarming of Austria by land, water and air, also came into operation. And thus Austria's sovereignty no longer existed except in appearance.

Renner's first Coalition Cabinet was followed in Oct. 1919 by a second one composed of the same parties. It had also the task of establishing normal relations with the neighbouring states. The visit made by the Chancellor to Rome in April 1920 on the invitation of Italy—on which occasion he was also received at the Vatican—was a not unfavourable introduction to these efforts. Among the "succession states" it was chiefly Czechoslovakia to which the Social Democratic party, which was as influential as ever, felt itself drawn, not only for economic reasons but also owing to the many points of contact which existed between its standpoint, with regard to Central-European problems, and that of circles in Prague. The frontier questions raised by the Peace Treaty were not settled in favour of Austria, which lost among other places the important railway centre of Gmund. In the economic negotiations advantage was taken by the Czechs of Austria's dependence on the Bohemian coal supply. On the other hand, in certain matters (naturalization, opinion, protection of minorities, division of collections and archives) a compromise was arrived at.

On the southern boundary Yugoslavia had to give up the strip of Styrian territory which had not been assigned her by

the Treaty of St. Germain. The Klagenfurt basin also remained Austrian, thanks to the result of the plebiscite of Oct. 20 1920, in which 60% of the votes were cast against Yugoslavia. Trade relations were established with the kingdom of the Serbs, Croats and Slovenes, as with other states, at first on a basis of exchange of commodities, but were later regulated by commercial treaties.

A variety of disturbances occurred from time to time in the relations with Hungary, where, at the beginning of Aug. 1919, the Soviet system had broken down. While the Christian Socialists viewed the new course of events in Hungary with sympathy, the Social Democrats and those with Great German sympathies—the latter because they saw their national aims endangered—were anxious lest the revolution in Budapest might bring about a restoration of the Habsburgs in the basin of the Danube. Causes of discord soon made their appearance. From the outset Budapest offered a scarcely veiled resistance to the cession of the Burgenland (German Western Hungary) to Austria. Austria declined to hand over Béla Kun and the other former "people's commissaries" who had taken refuge in Vienna, it even found itself bound, in consequence of the Copenhagen Agreement concluded with the party in power at Moscow, to aid the escape of the Hungarian Soviet leaders to Russia, in order to obtain the return of their own prisoners who were still kept in Russia. Only a few weeks before (June 20 1920) the International Trade Union Congress at Amsterdam had threatened Hungary with a boycott. Since this had only been exercised with severity in the case of Austria, the Hungarians regarded the Social Democrats of Vienna as having provoked it. The growing estrangement found expression in a few unfortunate frontier incidents, from the Hungarian side. It also had its effect upon the internal politics of Austria, for the Social Democrats sought to prove from documentary evidence that Hungarian Government officials, in their various conspiracies against the Austrian Republic, had relied on the support of the Vienna Christian Socialists.

At this point the coalition between the two great parties could no longer be maintained. The Christian Socialists had gradually become sick of it since the Social Democrats would not allow them as much influence as seemed in accordance with the increasing tendency of public opinion towards the Right. On the other hand, the Social Democrats, by their participation in a "bourgeois" Government, gave the Radical elements in their own party, as well as the Communists, a handle for attacking them, which threatened the carefully preserved united front of Social Democracy with serious danger. In view of this tension, an occasion which was not in itself of any special importance sufficed to split the Government coalition on June 20 1920. Otto Bauer could justly remark, on reviewing the past, that his party, by its coöperation with the Christian Socialists, had achieved as much as was possible for a beginning. The Republican legislation had answered, in so far as that was within the bounds of possibility, to the desires and interests of the urban proletariat. The position of the labouring class had also been recognized by the State. In the militia question the Social Democrats had entirely triumphed. Under the impression of the recent "Kapp-Putsch" in Germany they succeeded in forcing through a defense-law, which set up a machinery of soldiers' councils for the professional army provided for by the Peace Treaty; secured all political liberties, including also the right of coalition to those who had completed their service in the defense force, and by this means assured to the Social Democratic party for a long time to come predominant influence over the State's best source of power. As a set-off to these successes the Christian Socialists had managed with difficulty to protect their peasant franchise against inconvenient innovations, and to prevent questions of Church and State, education and the like from emerging in a critical form.

The place of the Renner Government was taken temporarily by a "Proportional Cabinet" ("*Proporz-Kabinett*") in which every party was represented by delegates without undertaking any responsibility for the Ministry as a whole, and it had to

carry on business up till the new elections, which were fixed for Oct. 17 1920. In the meantime it was naturally incumbent upon the Constituent Assembly to carry out its own particular task and give a definitive constitution to the "Federal State of Austria." Besides this the bill dealing with what had once been a considerable tax on property, namely the war-profits tax, was passed, under pressure from the Social Democrats in particular.

At the new elections the Christian Socialists obtained 82 seats, the Social Democrats 66, the Great German party (formed from the old German National party and kindred groups) 19, the German-Austrian Peasant party seven, the Bourgeois Labour party one. The distribution of the 92 seats in the newly created second chamber, the Federal Council (*Bundesrat*), represented a similar balance of power. On Dec. 9 1920 both Houses joined in the Federal Assembly (*Bundesversammlung*) in order to elect the Federal President, Dr. Michael Hainisch. The new Cabinet, composed of Christian Socialists and officials, was under the presidency of the Christian Socialist Dr. Michael Mayr,<sup>1</sup> who had already presided over the "Proprskabinet." While the Great German party assured the Cabinet of their benevolent neutrality, the Social Democrats went openly into opposition. They had had, indeed, to record a loss of votes in comparison with the 1919 elections, but they had none the less succeeded—in contrast with the fraternal conflicts of most other countries—in saving the party from disintegration. Even their relations with the Communists, thanks in no small degree to the platform of compromise adopted by the "Workmen's Councils" which were common to both sections of the party, had been tolerable up to the summer of 1920, though bitter hostilities afterwards broke out on both sides. Thus in Feb. 1921 the Austrian Social Democratic party had the satisfaction of holding together, in the spirit of its principles and under its patronage in Vienna, representatives of all international sections, from the Zimmerwaldians to the International Labour Association of Socialist parties. The tactical principles upon which this took place involved a compromise between the programme of action of the Second and the Third International, on which account the new Labour Association was given by its enemies the scornful title of the "International Two and a Half."

The pitiable condition of the Austrian State grew worse and worse. Neutral and former enemy countries did all they could to save the country from the worst; in particular, powerful relief measures of every kind had saved the population of Vienna from dying of hunger. It is true that the want of coöperation between the United States and the Western Powers had so far rendered it impossible to provide that far-reaching assistance which might ensure lasting salvation for Austria. Sir William Goode's plan for putting Austria into a sound financial condition, which clearly proved that the Austrian problem was not one of finance but a comprehensive political and economic one, had to be shelved, like those also propounded by Loucheur and Ter Meulen. At the end of March 1921 the Federal Chancellor Mayr learnt in London that the financial regeneration of Austria was to be handed over to the League of Nations, to which Austria had belonged since Oct. 1920. The "Austrian Section" of the Reparations Commission left Vienna a few weeks later (April 30 1921), the military supervisory commissions of the Allies having already been dissolved some time before. Financial delegates of the League of Nations arrived, to take up once again the study of the Austrian problem. The continued absence of organized help from the Entente had meanwhile—in spite of the counter-activity of the Vienna Christian Socialists, to whom is chiefly due the idea of a "Danubian Confederation"—strengthened Austrian opinion in favour of union with the large economic area of Germany. On April 24 1921 the overwhelming majority of the Tirolese declared themselves in this sense by a plebiscite which was carried out in defiance of the wishes of the Government; the Diets of other Territories proclaimed their desire to follow the example of Tirol. The ex-Emperor Charles's visit to

<sup>1</sup> A. Michael Mayr (b. 1866), director of archives, professor of history at the university of Innsbruck.

Hungary at Esster had also called attention once more to these political questions. This occasioned two serious parliamentary conflicts, in the course of which the Michael Mayr Government was at times only able to obtain a majority of one. It was further evident that in spite of its conservative character the Cabinet had been unable to bring about an improvement in relations with Hungary. It could only have been purchased at the cost of concessions which would practically have amounted to the renunciation by Austria of the Burgenland (German Western Hungary). The position of the Government was only strengthened to a certain extent by the fact that in May 1921 all parties assured the Government of their support in the economic and financial measures desired by the League of Nations.

See Dr. Karl Neisser, *Politische Chronik für 1918-20; Ein Jahr Republik Oesterreich (1920); Oesterreichisches Jahrbuch, 1920 (1921); Gustav Stolper, Deutschoesterreich als Sozial- und Wirtschaftsproblem (1921).* (E. G.-H.)

#### ECONOMIC CONDITIONS

The collapse of the Austrian Empire, as such, resulted in the rapid disruption of an extensive economic area and entailed the severance of an economically restricted German-Austria, which contained only little fertile land, from the agriculturally rich territories of the seceding states. Thus the early cessation of the food supplies which the states had been sending into Austria rendered the position worse, especially as regards Vienna, and even then, in the days of the transition period, the authorities had to appeal to foreign Powers to help in the relief of the food shortage. The anxiety to procure the primary food-stuffs remained the main preoccupation of the Austrian Government in the course of the ensuing two years. Accordingly, if the harvest returns of the years after the war be compared to pre-war showings, a marked falling-off of production is apparent. In the territory comprising the new Austria the net returns of the yield of wheat, rye and barley, which in 1914 amounted to 9,713,000 *metresentners*, showed in 1919 only 4,518,000 *metresentners*, and in 1920 an estimate of 5,300,000 *metresentners*. Even if the level of pre-war harvests should be attained, only about half the requirements of the population could be met. During the last years which preceded the war an average production of 5 million *mx.* of flour was established, while the requirements at the time amounted to 9.5 million *mx.* The position was about the same with regard to other items of the supply of victuals. When the food problem became acute, especially as concerned Vienna, it immediately raised the question of the future of this city as a metropolis; for Vienna was the heart of a large empire, the seat of the administration of a large number of provincial industrial undertakings, and the centre of commerce and banking. Here the people had spent the income which they derived from all parts of the monarchy. Only gradually was it shown, in the first year of the republic, that the economic predominance of Vienna reposed upon a much more solid basis than had been assumed in some quarters.

At the time of the collapse the anxiety concerning the food supply found a parallel in the solicitude to obtain coal, since the Austrian output was almost wholly negligible. This, like many other products of primary importance, could be acquired only with great difficulty even in foreign countries, and, save to the extent in which it was obtainable on credit, could only be secured in moderate quantities by the release of counter-values.

The economic structure of the new Austrian Republic is best illustrated by employment statistics, which show that in 1920 agriculture absorbed 40%, industry and commerce 35%, mercantile avocations and transport 17%, the public services and the free professions 8% of the population settled upon its territory. It follows that the people were pretty evenly divided between agricultural and commercial pursuits; industry was for the most part concentrated in and around Vienna, to which city 1,800,000 of the 6,500,000 inhabitants of the state belonged.

Of the land by far the greater part is in the hands of larger or smaller peasant proprietors; 38% is covered with forests, 24% is agricultural or horticultural, 16% grazing-land in mountainous regions, 11% meadows. Conditions are relatively favourable for

the raising of live stock, as the census of April 1919 shows as many as 1,952,000 head of cattle and 1,107,000 pigs, which in comparison to the returns of 1910 reveals a decrease of about 40% as regards the latter, of about 20% as regards the former.

Austrian industry suffered grievously from the disruption of the economic area. To quote but one example: The yarn which was spun in the territory of present-day Austria was for the most part woven in the countries S. of the Sudetic Mountains. For the Austrian cotton-spinning industry, with its 1-2 million spindles, could employ a maximum of about 30,000 looms, but only about 12,000 of these are situated in Austria, so that under present conditions two-thirds of the product of the Austrian cotton-spinners would have to be finished off abroad. The cloth, as a finished article, used to be made up in Vienna and thence consigned to Hungary, Galicia, and elsewhere. Similar conditions prevailed also in other branches of industry in the old Austria, but, so long as there was but one connected, economic area, these conditions evolved themselves naturally, being governed by the geographical position of the factory. The setting-up of customs tariffs along the frontiers of the states which arose upon the territory of the broken-up Austria entailed serious difficulties for all industries. The fact that Austria was cut off from the areas upon which she was wont to draw for her supply of coal became a consideration of moment, since only 6% of the demand could be met by the exploitation of her own resources, while the balance required had to be obtained abroad. Private establishments had to be rationed as regards coal, and the use of gas and electricity to be drastically curtailed. In Vienna it was at one time even necessary to cut industrial establishments off the power stations. Industry received but a fraction of the coal it required, and the ironworks, in particular, suffered heavily in consequence.

The principal industries of the Austrian Republic are as follows: First and foremost is the iron trade. (Under normal conditions the *Eisenerzberg* in Styria furnishes from 20 million mc. upwards of iron.) The industry lies within the area of the *Südbahn* and around Vienna; it furnishes raw material and semi-manufactured articles which also form an item of the export trade. Very highly developed, it employed in pre-war days some 30-40,000 hands and manufactured scythes, tools, axes, wire of all kinds, hard iron wares, etc. The manufacture of machinery gave employment to about 21,000 workmen, its specialty being agricultural machinery. There are four factories in Austria which construct locomotives, several which build wagons, motor-cars, etc. Of the textile industry of the old Austria the bulk is now outside her frontiers, but an important part has remained (in the Vienna area and the Vorarlberg). The great clothing industry of the old Austria had Vienna for its centre. Two branches of industry depended upon Austria's wealth in forests—(1) the important timber trade (including the saw-mills, of which 257 were worked by steam and 5,200 by water-power; further, the furniture-manufacture, occupying about 14,000 hands); (2) the paper industry, which under full pressure furnished, in partly manufactured articles, 12,000 car-loads of cellulose and 10,000 of wood pulp; in wholly manufactured articles 7,000 car-loads of cardboard and 18,000 of paper, more than half of the products named being available for export. Further, in the working up of paper Austria is capable of good achievement. The electrical industry can employ some 25,000 hands, and the rubber and leather manufactures are of importance. Another important raw material remains to be mentioned: within the territory of the Austrian Republic an output of 200,000 tons of magnesite was reached in 1913.

The two years succeeding the war were industrially unproductive in Austria, because there was a lack of numerous raw materials, which were not to be had even for payment, since, owing to the universal shortage, difficulties were everywhere put in the way of export. After the *débâcle*, war industries came to a sudden standstill. The worst period of crisis was in the winter of 1918-9, and it was only in the summer of 1919 that a slow economic recovery began, based for the most part on the possibilities of export due to the conditions of the foreign exchange;

at this time began on a large scale the "general clearance" of Austria by foreign purchasers who could take advantage of the low value of the Austrian *krona* abroad as compared with its purchasing-power at home.

The development of industry was wholly dependent upon the quotation of the *krona*, for in the spring of 1920 a slight improvement of the exchange in foreign markets caused a noticeable halt in exports, which only revived in the month of August of that year when the exchange was again on the down grade. In the autumn of 1920 a continuous improvement in the situation appeared in almost every industry; the frequent curtailments of working-hours gradually ceased, and new hands were engaged. By the close of the year the furniture-manufacture, clothing trade (including the specially prosperous shoe industry) and the leather trade showed well. Only the metal trades, which continued to suffer greatly from the want of raw material, could not definitely improve; the locomotive works and the electrical trade were fairly occupied, but the position was especially bad in respect of the manufacture of agricultural machinery and motor-cars.

In accordance with the social and political conditions of the first year of the war, a large number of social-political measures long demanded by the working classes had been passed. Of these some had been prepared and planned by the Austrian Government before or during the war, but had partly been shelved owing to political difficulties or the opposition of the classes interested in maintaining the old conditions; partly they had been unacceptable to the Government. Further measures of the kind seemed called for by the conditions of the moment, which urgently demanded State assistance for the classes of the population most hard hit by the economic depression, especially the rapidly growing class of unemployed whose urgency threatened violence. The most important measures were: enactment of the legal eight hours' working-day; new rules for work done at home and by children; prohibition of night work in bakeries; compulsory holidays for workers; compensation of workers and employees generally in the event of the transference of an industrial establishment or the sale of machinery abroad; legal regulation of collective bargains; establishment, on the analogy of the existing chambers of commerce and industry, of workmen's chambers (*Arbeiterkammern*) as the official representatives of the "estate" of workers; improvement of the conditions of domestic service by a special law.

A large part of this social-political legislation was occupied by the measures intended to combat the effects of unemployment. In addition to the common results of the ending of a great war, unemployment in Austria was increased, not only by the special causes already mentioned, but by the stream of Germans expelled from other parts of the former monarchy. Thus as early as Nov. 1918 State aid had to be introduced for industrial workmen and employees. The sums allowed for relief were fixed on the basis of the relief given in case of illness, and in Vienna, as a rule, attained the maximum provided for, namely six *kronen*, to which was added in the spring of 1919 a small bonus by the commune for fathers of families and in the beginning of 1920 a special additional grant by the State. The number of unemployed rose very rapidly: on Dec. 1 1918 for the whole of Austria the total was 46,000, on Feb. 1 1919 it was 162,000, on May 1 of that year the maximum of 186,000 was reached; but the decrease was slow, since the returns of Aug. 1 still showed 133,000 persons out of work, Nov. 2 87,000, end-Jan. 1920 69,000 and end-April 46,000. The number of unemployed was always greatest in the Vienna area, where the maximum was reached at the beginning of May with 132,000 unemployed, while on Nov. 22 there were 73,000 and end-April 1920 38,000 persons out of work. A very peculiar expedient was resorted to at the time when the conditions were at their worst. In order to occupy at any rate a part of the unemployed the factory-owners, who on April 26 1919 employed a minimum of 15 hands, were from May 19 of that year compelled to employ additional workmen up to one-fifth of their previous establishment and replace every man whose employ came to an end by a new man. This

measure, which was meant to remain in force for only a short time, was repeatedly prolonged all through 1920. Its terms allowed exceptions and modifications under certain conditions. But if industry was able to bear the weight of such measures at all, if it was found possible to comply with them at any rate on broad lines, that is probably due to the fact that when they were made trade was progressively improving.

The recovery of industry and quieting down of the political situation made it possible from Aug. 1919 to effect the necessary reduction in the relief of the unemployed, and by May 1920 to subject the whole matter of the relief of unemployment to legislative regulation. With this object in view—apart from the fixing of a maximum period of time within the space of a year during which relief was given—all unemployment doles were subjected to rigid conditions; further, all aid accorded was based on the principle of insurance, inasmuch as the State advanced the sums required for relief but thereafter recovered a third of the amount from the employers and a like proportion from the workmen by the contribution these were made to pay, so that it bore itself but a third of the total cost. The introduction of insurance against unemployment soon led to a considerable decrease in the total of persons who received relief payments (at the end of April a total of 46,000, of which 38,000 were Viennese cases, falling by the beginning of May 1920 to 19,000, of which 15,000 were Viennese). Thus from that time onward the number of unemployed in receipt of State aid decreased by about one-half. During the remainder of 1920 there was at first a rapid increase in unemployment, which was connected with the crisis then supervening (caused by the improvement in the exchange, which curtailed exports). By July the total of persons who were out of work and in receipt of relief reached 24,800 (of which total Vienna accounted for 19,500), but thereafter the totals again proved susceptible of rapid diminution, so that by the end of the year the decrease was illustrated by a return of 16,600 persons out of work (of whom 13,700 were Viennese). By the end of 1920 unemployment in Vienna was greatest among the metal workers (34,500) and unskilled hands (2,730), among shop assistants (1,338), the employees of hotels and restaurants (1,338), in the building trade (1,430), in the catering business (700). In this group, however, figures a large number of unemployed who were not in receipt of relief.

In the period which followed the termination of the war the Social-Democratic party acquired a leading rôle in the government of the country, its programme being to attain a new economic order by the nationalization of private enterprise. A number of laws were actually passed with this end in view. The law of March 14 1919 on the preliminaries of nationalization lays down in Paragraph 1: "On grounds of public utility suitable industrial concerns may be sequestered for the benefit either of the State, the Territories or the Communes, and may be administered by the State, the Territory or the Commune, or placed under the administration of public, legally recognized bodies." For the elaboration of further legislation aiming at nationalization a Government Commission on Nationalization was instituted and given the right to call as witnesses persons capable of giving information, inspect industrial establishments, take cognizance of the account books, etc. The law of May 15 1919, which set up the industrial councils, was also meant to serve the ends of nationalization, since on these councils the working-men were to gain an insight into the administration of undertakings and be trained for their future task of exercising a determining influence upon the industry. At the same time the system of industrial councils was so planned as to fit into the economic order of capitalist individualism. "The industrial Councils are instituted in order to understand and to foster the economic, social and cultural interests of the working-men and the employees in the undertaking." They were to safeguard the observance of contractual obligations entered into collectively, and the compliance with laws protecting the working-men, etc.; under certain circumstances they could demand the production of the balance-sheet of the undertaking; in the case of public companies they deputed two representatives into the

council of administration or the board of directors, though these were not conceded the right of speaking on behalf of the company or signing for it and had no claim to monetary compensation for services of this nature. The industrial councils undoubtedly proved useful in maintaining discipline in the factories during times of disturbance. The law of May 30 1919, on the procedure in cases of expropriation of industrial concerns, lays down very general maxims which deal with the provisions of future expropriation bills. Of importance is only the proviso that the process of expropriation is initiated by a resolution of the Government, which in itself entails definite legal consequences. The provisions for indemnification in the case of future expropriation, about which a lively discussion had raged, are very vague. The law of July 29 1919 on socialistic enterprises seeks, with a certain tendency to the idea of guild socialism, to remodel the legal forms of business undertakings so as at least to prepare for the transition to new economic forms. "The socialistic institutions (*gemeinwirtschaftliche Anstalten*) are founded by the State, by the Territory, by the Commune, or by a majority of these territorial corporations, with the object of transferring existing private and public undertakings to the proprietorship or the administration of the socialistic institutions, or of starting new undertakings in this form." These institutions were to be conducted by, among others, the corporations by which they had been established, the industrial councils of workmen and employees, and organizations representing a considerable part of the consumers of the institution's output. A series of such institutions was founded, partly in order to take over Government factories formerly engaged in turning out war material. Further socializing measures were arrested by the change in the internal political situation.

The economic condition of Austria noticeably improved in the course of 1920; "labour unrest" abated considerably, and by the beginning of 1921 a distinctly favourable progress was recorded in many branches of industry. This, however, could not obscure the fact that the development reposed upon thoroughly unsound basic conditions, especially upon the difference in the price level at home as against foreign countries with a healthy exchange, on a scale of wages which, calculated in foreign currencies, was extraordinarily low, while the national budget was weighted with milliards spent in the cheapening of food. As Austria could not within a measurable time meet her own food requirements she was dependent upon the export of manufactured articles. It could only be hoped that, on a return to normal times, Austria, after the recovery of the exchange, would become a suitable field for industry capable of meeting competition in the world market. The town of Vienna, thanks to its central position in Europe, must always be an emporium of increasing importance and also one of the principal centres of European trade. (K. P.; R. Sz.)

**AUSTRIC FAMILY OF LANGUAGES.**—An addition must be made to the classification of languages given in the article PHILLOLOGY (see 21.426) as the result of the further researches since 1908 in the Malay-Polynesian field and S.E. Asia. The establishment of the "Austrian family" of languages may well be considered the most important achievement of these later years in the work of comparative philology.

The essential unity of the Oceanic languages, though partially recognized long ago by Humboldt in his *Kovisprache*, was not completely demonstrated until much more recent times. The connexion between the Polynesian and Indonesian languages (including the geographically outlying Malagasy) met with ready acceptance, but the affiliation of the Melanesian was not so easy. The difficulty was partly due to purely linguistic differences, the Melanesian type of speech being superficially very different from the Indonesian and Polynesian, partly to the diversity of the races which raised the natural, but quite unjustifiable, presumption that the languages could not be of the same stock. It was, however, eventually proved that Melanesian could not be kept out of the Oceanic family,<sup>1</sup> and it has since been shown that Micronesia, though different in race,

<sup>1</sup> Kern, "De Fijidj-taal," *Verhand. Kon. Akad. v. Wet.* (Amsterdam, 1896), Afd. Letterk., Deel xvi.; "Over de verhouding van het Nubobrach tot de Maleisch-Polynesische talen," *Actes du VIe Congrès International des Orientalistes.*



falls linguistically into the Melanesian section. Also it ultimately became plain that of these three subdivisions Indonesian best represented the archaic family type, while Polynesian at the other extreme had gone furthest in the direction of simplification and decay.<sup>1</sup> This was established, by the strictest scientific proof, the existence of the Oceanic or Malayo-Polynesian family of languages, extending from Madagascar in the west to Easter I. in the east, and from Formosa and Hawaii in the north to New Zealand in the south.

Meanwhile further exploration and research had revealed the existence in New Guinea and some of the neighbouring islands of a number of languages which could not be fitted into this scheme of classification, and did not even apparently form any family of their own, but only a number of distinct groups between which no ultimate relationship could be safely asserted.<sup>2</sup> These so-called Papuan languages (which have since been found in portions of Dutch and German as well as British New Guinea) are therefore to be regarded as a purely provisional group, the time for their systematic classification not having as yet arrived. But it is quite certain that they have nothing whatever to do with the Oceanic family, though some of the neighbouring members of the latter have undoubtedly been influenced and to some extent modified by Papuan languages, and also vice versa, particularly in the matter of syntax.<sup>3</sup> Moreover there exists in an outlying corner of Eastern Indonesia a small enclave comprising a number of closely related and very curious languages which differ profoundly from their neighbours of the Oceanic stock. These are the languages of the northern peninsula of Halmahera (or Jilolo), together with Ternate, Tidore, and a few other small adjacent islands. In spite of some attempts that have been made to show their ultimate connexion with the Oceanic family,<sup>4</sup> it cannot be said that the thesis has been proved or even rendered very probable. It is at least as likely that they are remnants of some archaic Papuan group, though the tribes that speak them are not Papuan in physical type.<sup>5</sup>

The Oceanic languages having thus been delimited,<sup>6</sup> there remained the further question of their source of origin. By an ingenious comparison of purely linguistic data, Kern had shown<sup>7</sup> that the common mother-tongue from which they were derived must have been spoken on some long coastline in the tropics, the east coast of Indo-China seeming on the whole to be the most likely one. Here there were actually languages, such as Cham and its immediate neighbours, which were plainly in some way connected with the Indonesian branch of the Oceanic family. But no really satisfactory attempt could be made to connect the Oceanic with any of the different groups of Indo-Chinese languages until the latter had been properly classified. This was done by Forbes<sup>8</sup> and carried further by Kuhn,<sup>9</sup> but the final achievement was the work of W. Schmidt. In a series of admirable monographs<sup>10</sup> he succeeded in providing the intimate connexion of the aboriginal languages (Sakai and Semang) of the Malay Peninsula, the Mon-Khmer group, the Palaur-Wa-Riang group of the Shan states, Khasi in Assam, Nicobar, and finally the Munda languages of India proper. All these are characterized by a structure based ultimately on monosyllabic roots from which more complex words are formed by means of pre-

fixes and infixes (in the case of Munda and Nicobar, suffixes as well). Both in structure and vocabulary they are altogether different from the large family, or agglomeration, of languages to which Tibetan, Burmese, Siamese and Chinese belong.

On the other hand a considerable amount of work had been done, mainly by Dutch scholars such as Van der Tuuk, Kern, and Brandes, to analyze the structure of the Oceanic languages; they succeeded in showing that the superficial dissyllabism characteristic of the family was really the result of an ancient agglutinative system building upon originally monosyllabic roots.<sup>11</sup> This left the way open to Schmidt to show<sup>12</sup> that his newly formed synthesis of languages, which he proposed to call Austroasiatic, was ultimately related to the Oceanic (or as he would style it Austronesian) family, so that the two could be conveniently grouped under the generic name "Austriac." Schmidt's arguments were based both on similarity of structure and numerous cases of identity between the very roots of the two families; and so far as they were confined to linguistic classification his conclusions have met with general acceptance at the hands of those best qualified to judge. But his attempt to establish a corresponding anthropological unity of the very diverse races speaking all these different tongues was not so successful and must be regarded as altogether premature. Most of these populations are blends, and though conceivably there may be some thin strain of common blood running through all of them, it is impossible as yet to define it or compare it with the common elements of their speech. Nor is any such assumption a necessary conclusion from the linguistic data. The synthesis of the languages has established a purely linguistic unity, implying no identity of race and admitting the existence here and there (even among the Negroes of the Malay Peninsula, in Melanesia and also in parts of Polynesia)<sup>13</sup> of traces of older aboriginal languages embedded, like flies in amber, in the prevailing type of speech.

**BIBLIOGRAPHY.**—Brandstetter, *Tagalen und Madagassen* (1902); *Ein Prodrum zu einem vergleichenden Wörterbuch der Malaiopolynesischen Sprachen* (1906); *Gemeindeindonesisch und Urindonesisch* (1911); *Das Verbum . . . in vierundwanzig Indonesischen Sprachen* (1912); *An Introduction to Indonesian Linguistics* (1916); Ferrand, *Essai de phonétique comparée du malais et des dialectes malgaches* (1909); Kern, "Taalvergelijkende Verhandeling over het Aneijumtsch, met een Aanhangsel over het klankstelsel van het Eromanga," *Verhand. Kon. Akad. v. Wet.* (Amsterdam, 1906), N. R., D. viii., No. 2; Schmidt, "Ueber das Verhältnis der Melanesischen Sprachen zu den Polynesischen und untereinander," *Sitzungsber. d. Kais. Akad. d. Wiss. in Wien*, Phil.-hist. Kl., Bd. cxli., No. vi.; Die Jambir-Sprache, (Deutsch-Neu-Guinea); *Ibid.*, Bd. cxliii., No. ii.; Meyer, "Die Papuanerassen in Niederländisch-Neuguinea," *Globus*, xcii., pp. 189-92; Finot, "Les dialectes indochinois," *Bull. de l'É. R. d'Extrême-Orient* viii., pp. 221-33; Cabaton, "Dix dialectes indochinois," *Journal Asiatique*, Mars-Avril, 1905, pp. 265-344; Aymonier and Cabaton, *Dictionnaire Lam-français* (1906). (C. O. B.)

**AUTOMOBILE:** see MOTOR VEHICLES.

**AVEBURY, JOHN LUBBOCK, 1ST BARON** (1834-1913), English banker (see 3.51\*), died at Ramsgate May 28 1913.

**AVIATION:** see AERONAUTICS.

**AYLMER, SIR FENTON JOHN** (1862- ), British general, was born April 5 1862, and joined the army in 1880. He served in the Burma campaign and the Hazara expedition of 1891, and greatly distinguished himself in the Hunza-Nagar operations, winning the V.C. and promotion to brevet-major in 1892. He took part in the Isazai expedition of 1892 and for his services in the relief of Chitral in 1895 was promoted brevet lieutenant-colonel. After some years on the staff, he commanded brigades in India from 1904 to 1910, was promoted major-general in 1909, and in 1912 became adjutant-general at Simla. This position he held until Nov. 1915 when, now a lieutenant-general, he was summoned to Mesopotamia to lead the force being organized for relief of Kut. This was composed mainly of two Indian divisions which had been fighting in Flanders and were arriving in dribbles. The urgency of the situation obliged Aylmer to push up the Tigris with little preparation; but he inflicted two severe defeats upon the Turks before being brought up, 23 m. short of Kut, by the lines of Hannah on the left bank of the river. He halted for six weeks for reinforcements and war material before striking

<sup>1</sup> Conveniently summed up in Brandstetter's *Wurzel und Wort in den Indonesischen Sprachen* (1910).

<sup>2</sup> "Die Mon-Khmer-Völker," *Archiv. f. Anthr.*, xxxiii., pp. 59-109; and in French "Les peuples Mon-Khmer," *Bulletin de l'École Française d'Extrême-Orient*, viii., pp. 213-63, viii., pp. 1-35.

<sup>3</sup> Skeat and Blagden, *Pagan Races of the Malay Peninsula*, vol. ii., Language; Ray, "The Common Origin of the Oceanic Languages," *loc. cit.*, and *Jour. Anthr. Inst.*, xxvi., pp. 204-3.

<sup>1</sup> S. H. Ray, "The Common Origin of the Oceanic Languages," "Hellas" *Revue Polyglotte Internationale*, VIe Année; Thalheimer, *Beitrag zur Kenntnis der Promonia der Sprachen Mikronesiens* (1908), reviewed by Ray in *Man* (1908).

<sup>2</sup> Ray, "The Languages of British New Guinea," *Jour. Anthr. Inst.* xxiv., pp. 15-39; *ibid.* xxvii., pp. 204-5; *Reports of the Cambridge Anthropological Expedition to Torres Straits*, vol. iii., Linguistics (1907).

<sup>3</sup> W. Schmidt, *Man* (1907) 106; Ray, *Jour. Anthr. Inst.* xxx. (Anthr. Rev. and Misc. 50).

<sup>4</sup> Kern, *Bijdr. tot de Taal-, Land-, en Volkenkunde van Nederlandsch-Indië* (1891), Deel xl., pp. 493-530. See also A. Huetting, "lets over de Ternataansch-Halmaherische Taalgroep," *ibid.* (1908), lx., pp. 369-411.

<sup>5</sup> Schmidt, "Die sprachlichen Verhältnisse von Deutsch-Neuguinea," *Zeitschr. f. Afrik. u. Ozean. Sprachen*, Jahrg. v. and vi., espeo vi. pp. 74-99. See also Van der Veen, *De Noord-Halmahera'se Taalgroep* (1915).

<sup>6</sup> It is hardly necessary to add that the languages of Australia and the now extinct dialects of Tasmania lie entirely outside this sphere.

<sup>7</sup> "Taalkundige gegevens ter bepaling van het stamland der Maleisch-Polynesische volken," *Verh. Kon. Akad. v. Wet.* (Amsterdam, 1889), Afd. Letterl. IIIe R., Deel 6.

<sup>8</sup> *Comparative Grammar of the Languages of Further India*.  
<sup>9</sup> "Beiträge zur Sprachkunde Hinterindiens," *Sitzungsber. d. K. Bayer. Akad. d. Wiss.*, Phil.-hist. Kl. (1889).

<sup>10</sup> "Die Sprachen der Sakei und Semang auf Malakka und ihr Verhältnis zu den Mon-Khmer-Sprachen," *Bijdr. tot de T. L. en V. v. Ned.-Indië*, 1901, Deel lii., pp. 399-583; "Grundzüge einer Lautlehre der Mon-Khmer-Sprachen," *Denkschr. d. Kais. Akad. d. Wiss. in Wien*, 1905, Phil.-hist. Kl., Bd. iii.; "Grundzüge einer Lautlehre der Khasi-Sprache in ihren Beziehungen zu denjenigen der Mon-Khmer-Sprachen," *Abhandl. d. Königl. Bayer. Akad. d. Wiss.*, 1905, I Kl., Bd. xxiii., Abt. iii. and *op. cit.* inf.

\* These figures indicate the volume and page number of the previous article.

stream, this time on the right bank. His plan involved a long night march and assault on the enemy defenses, some 10 m. short of Kuch, at daybreak. But one of his divisions did not arrive on time, and when delivered the attack failed; Aylmer was thereupon replaced by another general. He was given the K.C.B., and after returning to India he commanded a division there for some time. Gen. Aylmer was the author of an important tactical study on *Protection in War* (1912).

**AYUB KHAN** (1855-1914), Afghan prince, son of Share Ali (see 3.77), died at Lahore April 6 1914.

**AZCARATE, GUMBERSINDO** (1840-1917), Spanish politician and lawyer, was born at León, Spain, Jan. 13 1840, and was educated at the university of Oviedo, whence in 1858 he went to Madrid and graduated in law, science and philosophy (1861). After obtaining a post as assistant in a public office he returned in 1868 to Madrid as assistant professor of comparative jurisprudence and in 1872 was appointed professor. He was of the little band of Liberals who preferred to resign in 1873 rather than submit to the famous Orovio decree limiting the liberty of the chair. He was, however, reinstated six years later and became one of the central figures of the group headed by Don Francisco Giner, to which Spain owes most of its up-to-date educational institutions. He sat as deputy for León from 1886 to 1890, from 1891 to 1895, and for later periods. In 1892 he became professor of private law at Madrid. In politics he was a moderate republican. He was a keen student of English institutions and an admirer of English political life. In later years he accepted a share in official administration, notably as the head of the Instituto de Reformas Sociales, which he had invested with his incomparable moral authority. He had also approved of the Reformist evolution of Señor Melquiades Alvarez. The austerity of his political views was such that on being defeated at the last general election he fought, he refused a seat as senator for life, which was offered him by the Government. He died at Madrid Dec. 14 1917.

**AZCÁRRAGA Y PALMERO, MARCELO** (1832-1915), Spanish soldier and politician, was born in Manila in 1832. He early saw service in Spain during the mutinous outbreaks in Isabella's reign (1854-6) and was next sent to Cuba and on a special mission to Mexico, later belonging to the expeditionary army against that country. He was promoted colonel in 1866 and entered the Ministry of War. He was employed by the Spanish republican Government of 1868 as chief of staff at Cartagena and later of the army of the North. After the accession of Alphonso XII. he became field marshal and Under-Secretary for War. He sat as deputy for Morella in the first restoration Parliament. In 1885 he was elected senator for Navarre and was Minister for War under Canovas (1891-2) and again in 1895, becoming head of the Cabinet in 1897 after Canovas's assassination. In Sept. 1904 he retired from the army at the age of 70 with the rank of general, and in Dec. of that year was again for a few weeks prime minister. Throughout his political career he was associated with the Conservatives but took little part in party struggles. He died May 30 1915.

**AZERBAIJAN**.—The republic of Azerbáiján had no political existence until the year 1917, when the Trans-Caucasian provinces of the Russian Empire, exposed to the enemies of Russia, found in the collapse of the empire the need and opportunity of striking out for themselves. Not has Azerbáiján any national traditions or history; scarcely, till lately, had her people a racial consciousness, the name, even, did not apply to the present state. Under Russian administration Trans-Caucasia comprised six "Governments." Of these Baku, with a coastline on the Caspian Sea, and Elisavetopol, adjoining Baku on the west, united to form the republic of Azerbáiján. The territory included in the two "Governments" was, originally, the portion of the Persian province of Azerbáiján (see 3.80) ceded to Russia as long ago as 1813 under the predatory Treaty of Gulistan. Once a Russian possession, the ceded area lost all connexion with its previous name. But when in 1917 the two "Governments" combined to declare a joint independence the Persian name was adopted for the infant state from motives of policy—it was hoped

thus to attract to the new republic the Persian remainder of the old province of Azerbáiján, peopled chiefly by the same stock.

*Geographical Position*.—Looked at broadly the republic occupies the lowlands of two great Caucasian river basins—the Kuru and the Arax—enclosed by the Caspian Sea, the Caucasus mountains, the watershed parting of the Black Sea, and the highlands of Armenia and Persian Azerbáiján. This fertile territory, rich also in oil, has a coastline to the Caspian exceeding 400 m., and stands athwart the chief line of communication between the Black Sea and central Asia. Two-thirds of its population is a homogeneous race of Tatar origin closely related to the Anatolian Turk. They speak a form of Turkish, but, unlike the Turk, are Moslems of the Shiah sect; with their Szani kinsmen of Anatolia they have, however, a definite sympathy.

*Area and Population*.—The area of the "Governments" of Baku and Elisavetopol together was about 32,000 sq. m.; their pop., by the Russian census of 1910, somewhat less than 2,600,000. This total comprised, in round figures, 1,740,000 Moslems, 540,000 Armenians, 230,000 Russians and other Europeans, and diverse elements as the remainder.

The territory claimed by the republic is not, however, altogether that of the "Governments" of Baku and Elisavetopol; but it is only of these that definite figures of area and population can be given. For districts containing in all some 15,000 sq. m., partly within and partly without the boundaries of the two "Governments," and carrying a pop. of nearly a million, are in dispute between Azerbáiján and the adjoining republics of Erivan and Georgia. Settlement of these disputes may give Azerbáiján a greater or lesser area and population than had the two "Governments."

*Industries and Communications*.—The chief industry of the country is the production, refining, and exportation of oil and petroleum. Within 50 years the immense oil deposit discovered on the Apsheron peninsula had created the city of Baku, now the capital of Azerbáiján, with a pop. of 250,000. Indeed the production of oil in vast quantities in this region has had far-reaching indirect political results. It has given the state an importance out of proportion to its population, by placing wide adjoining regions in a position of dependence regarding the vital commodity of oil for light and fuel. Still more, it has profoundly affected the direction given to lines of railway, and the development of rail and other forms of communication.

By this process, and from the position of Baku as a port on the Caspian Sea—a sea nearly twice as great in area as all the Great Lakes of America together—the city became a centre with lines of communication, by rail and sea, radiating from it in all directions. From Baku the Caspian Sea is crossed by ferry steamers to Krasnovodsk; and thence a railway runs for nearly 2,000 m. through central Asia, skirting the Afghan frontier, and reaching the Pamirs. The city is in direct rail communication with Moscow; by railway, sea, river or canal every part of European Russia, in fact, is within reach. By sea N. Persia ports are only one day's steaming. Through Trans-Caucasia Baku is in direct railway communication with Erivan, Tabriz in N.W. Persia, Erzerum in Turkey, and Batum on the Black Sea. Batum, indeed, is complementary to Baku as the terminus not only of the Baku-Black Sea railway, and of the pipe-line for conveying oil, but as the one port by which the great inland centre of communication and oil production, embedded deep in western Asia, can have trade intercourse with the oceans and outer countries of the world. The interdependence of Baku and Batum was well enough with all Trans-Caucasia under one Government; with the two cities in separate states friction became inevitable:

Had there been no oil at Baku events in the Near and Middle East during the years 1913-21 would have shown a striking dissimilarity from the events which actually befell. Such is the important position Azerbáiján fills, by reason of Baku, on the confines of south-eastern Europe and western Asia.

*External Influences*.—In the Pan-Islamic dreams cherished by the Young Turk leaders of Turkey, the republic, with Persian

Azerbaijan, forms the essential connecting link between Islam of the West and Islam of central Asia and India. Pan-Islamic policy therefore closely affects Azerbaijan. But a further and more serious disturbing influence has been provided by Bolshevik Russia. For economic reasons, and in pursuit of her ambitions and policy in south-western and central Asia, the geographical position held by Azerbaijan made control of the republic a pressing necessity. The short and varied history of this small Caucasian state is, in consequence, concerned chiefly with the interaction of Turkish and Russian policy, and the inevitable question of Armenia and the Armenian people.

*History.*—The history of Azerbaijan as an independent state may be said to have begun on Sept. 20 1917. During the spring and summer of that year upheaval in Russia had passed from symptoms to facts of omen for the world. In March the Government resigned, a Provisional Government was proclaimed, and the Tsar abdicated; and in April the Provisional Government issued its proclamation declaring for the self-determination of peoples and the establishment of a lasting peace. In June the Black Sea fleet mutinied, and the Russian armies in Asia Minor, saturated with Bolshevik theories and shouting "No annexations and no indemnities!" abandoned their positions before the enemy and retired behind the Russo-Turkish frontier of 1914. On Sept. 15, Russia became a republic.

Need for common action by the Caucasian peoples was evident, as the Turkish front was held now by troops whose military value was fast disappearing. There was, further, at least on the part of Georgians and Armenians, a genuine desire to use the opportunity for securing some form of independence which should safeguard their national rights. The creation of the Russian Republic was followed, two days later, by a Council of the Trans-Caucasian peoples, assembled at Tiflis, proclaiming Trans-Caucasia a Federal Republic. This step involved removing a Russian Bolshevik Commissar who had already been sent to Tiflis to replace the Viceroy and Commander-in-Chief, the Grand Duke Nicholas. The Commissar was ejected, but he transferred himself to Baku and there with Armenian aid established a Bolshevik Government. But the affairs of the Federal Republic did not prosper. Between Georgian and Armenian Christians, and the Tatar Moslems of Azerbaijan, were antipathies of race and faith not to be suddenly diminished or held in check. Each people, too, had its own particular interests to consult. Jealousies and rivalries were acute; Erivan and Azerbaijan had deep suspicions that Georgia was scheming to use the Federal Republic for converting all Trans-Caucasia into a Georgian state. A fundamental opposition of outlook also existed on the part of each. All three desired to come under British protection; but that being impossible Azerbaijan stood out for Turkey, Armenia for Russia, and Georgia for Germany as the powers best suited and able to assure Trans-Caucasian independence. To the leaders of each of the federated peoples, in fact, the essentials of a rapidly changing situation ever appeared different.

The Treaty of Brest Litovsk, between Germany and Russia, signed on March 3 1918, was followed by a Turkish invasion of Armenian territory in order to occupy the districts awarded Turkey under the treaty. Batum was another district allotted to Turkey, subject to self-determination by the inhabitants; but Georgia believed that with German aid the province might be preserved for herself. In effect the Federal Republic was now at war with Turkey, though with no intention or possibility of concerted action amongst its peoples, and the Turkish occupation proceeded in spite of resistance on Armenian territory. Batum, too, was entered by Turkish forces on April 15. In these circumstances the republic resolved, on April 23, to make a formal declaration of independence, and to open peace negotiations with the Turks. But a German penetration of Trans-Caucasia from the Ukraine was now in sight. Odessa and Sevastopol were both in German hands at the beginning of May, and Georgian policy looked more and more definitely to Germany, to the exclusion of the wider interests of the Federal Republic. A few days later German and Turkish delegates reached Batum

to negotiate peace between Georgia and Turkey. This matter completed, Georgia and Germany concluded a treaty between themselves, by which German troops were admitted to the country, and Georgia received promises of protection, the maintenance of her independence and financial assistance.

As has been said, a Russian Bolshevik Government had been established at Baku after the founding of the Federal Republic of Trans-Caucasia. The area it controlled was small, but the Government had the advantages of position, supplies of fuel and food, and the comparative wealth afforded by the large and prosperous population. The Russian element behind the Government was also supported by local Armenians, a section of the inhabitants numbering some 60,000. These Armenians were under the influence of the Dashnakists, the Armenian revolutionary society of extremists, whose methods were violence, and who leaned towards Bolshevik Russia. And now, early in March, when the affairs of Trans-Caucasia were at their lowest, and the existence of the Federal state hung in the balance, the Russians and Armenians of Baku ejected the Tatar Moslems of the city, and massacred some thousands. During the succeeding three months, massacre of Moslems by Armenians spread to various parts of what had been Russian Armenia. With Georgia in private alliance with Germany, and Armenians massacring Azerbaijan Moslems whenever opportunity offered, the Federal Republic of Trans-Caucasia had become to all merely an empty name.

The Federal Republic was dissolved on May 26 1918. On that date Azerbaijan and Georgia each proclaimed its separate existence as an independent republic and formed a National Government; at the same time the National Council of Armenia took control of Armenian affairs. As the independent Bolshevik Government of Baku still existed Elisavetopol became the capital of Azerbaijan for the time being. Turkish troops were now admitted to the Tatar Republic; and others, followed by Germans from Georgia, reoccupied Tabriz, the capital of Persian Azerbaijan, at the end of May. The Pan-Islamic policy of Turkey appeared to be prospering at this time, and its leaders looked eastward to making their next step into central Asia. With this as a possibility a small British column under Gen. Dunsterville advanced from Mesopotamia through western Persia to the Caspian, and passing thence by sea reached and occupied Baku on Aug. 16 1918. Its purpose was to countenance and support the Russo-Armenian force holding the town and to assist the republic of Erivan, and thus prevent Turkish or German operations in central Asia. But the assistance and coöperation expected of the local troops did not come up to anticipation; a large Turkish force compelled the British to disembark on Sept. 13; and Baku fell the following day. But Turkish and German operations in these regions were drawing to an end. The Armistice between the Allies and Turkey, signed on Oct. 30, and between the Allies and Germany 12 days later ensured the evacuation of Trans-Caucasian and Persian territory by Turkish and German troops. A British force from Persia reoccupied Baku on Nov. 16, a British garrison was placed in Batum on Dec. 27; and before long a whole British division had reached Caucasus to ensure the evacuation of Turks and Germans. The railways were repaired, and through traffic between the inland republic and Batum resumed under a British Board of Railway Control, thus preventing the acute friction of the past.

On the withdrawal of Turkish troops from Baku the Government of Azerbaijan was established there, and endeavoured to organize an administration. This was a work of infinite difficulty, for though the Mousavet party in power meant well, every kind of administrative experience and knowledge was lacking. The British military authorities assisted, but soon found it necessary to take over multifarious civil functions, from providing and rationing foodstuffs, suppressing profiteers, working the oil and shipping industries, and managing the State bank, to the administration of Posts and Telegraphs, Police and Justice. For the first time since Russian Government ceased in Trans-Caucasia order appeared in the republic. But the

change depended on foreign ability and experience, and when the British troops were withdrawn in Aug. 1919 Azerbaijan relapsed into administrative confusion. An inter-state control of railways only was provided with some success, as a matter vital to all Trans-Caucasia.

The Peace Conference of the Allies which began its sittings in Paris on Jan. 18 1919 did not greatly affect Azerbaijan, though the republic sent a delegation to represent its claims to large territorial extensions. The course taken by events in Trans-Caucasia before the Treaty of Sévres was finally drafted doubtless placed Azerbaijan outside the area to which it was thought treaty provisions could be applied. Except regarding frontiers in dispute between Azerbaijan and Armenia the Treaty of Sévres, therefore, avoided matters affecting the Tatar Republic. For these frontiers it provided that they should be settled by direct agreement between the states concerned; and, failing such agreement, they were to be determined by the principal Allied Powers.

The Conference gave, however, no little attention to the problems of Trans-Caucasia. Early in 1919 it offered Italy control of the whole area, she having many interests there; but the offer was declined after consideration. As an emergency measure the Supreme Council appointed an Allied high commissioner to prevent territorial disputes developing into hostilities between the republics; and by his influence neutral zones for the time being were established, and the situation was temporarily eased. But months passed and the Conference became more and more chary of intervening in Trans-Caucasian affairs, especially in view of Gen. Denikin's operation in Cis-Caucasia, and his aim of reuniting south-eastern Russia. Stated shortly the shadow of Russia—Russia both of the present and of the future—lay over the land and created an incalculable situation. *De facto* recognition was, however, accorded all three republics. It should be noted, further, that in the draft of the Treaty of Sévres the importance of Batum to Azerbaijan and Armenia was recognised by making the town and surrounding territory a free state under the League of Nations, and giving the inland republics definite rights in the port and of access by rail. But this plan fell through, and Batum was returned to Georgia, under an agreement confirming Azerbaijan and Armenia in the privileges they were to have received from the free state of Batum.

The Turkish Nationalist movement which became all-powerful in Anatolia in consequence of the Treaty of Sévres had a serious influence upon the republic of Azerbaijan. Nationalist Turkey and Soviet Russia each found itself opposed to the Allied Powers. They therefore followed a common policy up to a point; and Turkish Nationalism and Russian Bolshevism went hand in hand, supplying each other's needs as far as might be, whether of means, material or opportunity. Turkey sought to recover the provinces in Trans-Caucasia from which she had been ejected by the Allies in 1918; she also required munitions from Russia, and direct access to Azerbaijan and central Asia in execution of her Pan-Islamic ambitions. Russia had her own quarrel with

the Allies to pursue, and her revolutionary mission to accomplish where she could. The oil of Baku, further, was a necessity for her economic life. These different aims of both countries converged on Trans-Caucasia, and implied the bringing of Turkish and Russian territory to a coterminous frontier—at least to a common frontier of effective control. Once this was attained all other things would be secured, including direct railway communication between Russia and Anatolia. Denikin had been driven out of Russia and now only the independent republics of Azerbaijan, Erivan and Georgia stood in the way.

Russia therefore prepared to set up a Soviet Government in Azerbaijan, and under cover of this change reestablish Russian control first there, and afterwards in all Trans-Caucasia. On April 28 1920 the XI. Soviet Army from Cis-Caucasia, some 50,000 strong, entered Baku without fighting. Simultaneously a rising of local Bolsheviks declared the Republican Government deposed, and established in its place a Soviet Government in alliance with Moscow. The Russian army, it was said, had only come to place the proletariat of Azerbaijan upon its feet. Effective opposition to the revolution was found impossible. The Azerbaijan army was disbanded; a revolutionary committee set up which sent the members of the late Government and many leading anti-Bolshevik citizens to execution; and Bolshevik economic theories were rigorously applied. Having seized the railways and consolidated their position in the country the Bolsheviks attacked Georgia and Erivan across the frontiers of Azerbaijan, but were repulsed without much difficulty. Russia's campaign in Poland was in progress at the time, and not going well, and further aggressions in Trans-Caucasia were therefore suspended. During this pause a Tatar rising took place at Elisavetopol, in which several thousand Bolsheviks were massacred. The rising was promptly suppressed by Bolshevik troops; and they, aided by local Armenians, retaliated by massacring, it is said, some 15,000 Tatars of both sexes and all ages. From this affair arose the hatred which the Tatars of Azerbaijan have since displayed against the Bolsheviks.

Further Bolshevik and Turkish operations against Georgia and Erivan do not properly belong to Azerbaijan history, but they cannot be altogether ignored. Suffice to say that when Russia, in the autumn, was relieved of her Polish embarrassments, and the campaign of Gen. Wrangel from the Crimea had plainly failed, she and her Turkish Allies turned their attention once again to Trans-Caucasia. By the end of Nov. both Georgia and Erivan were crushed, and Soviet Republics, dependant on Moscow, established in place of the National Governments. Turkey regained the districts of Ardahan and Kars; in addition she was given the strip of Armenian territory through which passed the railway from Azerbaijan to the Turkish frontier; but Russia with an eye to her own future, insisted that Batum should form part of Georgia, and her will in the end prevailed. Russia, in fact, had recovered all but an insignificant portion of her Trans-Caucasian provinces; and Azerbaijan, Georgia, and Erivan ceased to exist as independent states, except in name.

(W. J. C.)\*

**BACCELLI, GUIDO** (1830-1916), Italian physician and politician, was born at Rome 1830, and died at Rome Jan. 11 1916. After graduating in medicine at the university of Rome, he was appointed assistant professor of medical jurisprudence in 1856, and some years later became professor of clinical medicine. He soon acquired a great reputation as a practising physician, being especially noted for the accuracy of his diagnosis, and he devoted himself particularly to the pathology of the heart and to malaria; his studies on the latter subject proved of great value for the reclamation of the Roman Campagna and other fever-stricken zones. In 1875 he was elected deputy for the 3rd Div. of Rome, which he continued to represent until his death. He was Minister of Education in the Cabinets of Cairoli (1879-81), Depretis (1881-7), Crispi (1893-6), and Gen. Pelloux (1898-9), and of Agriculture under Zanardelli (1901-3); from 1889 to 1893 he was vice-president of the Chamber. A keen classical scholar, he took an active interest in archaeological matters, although in some of his projects, such as the famous *Passaggiata Archeologica* in Rome, he showed more enthusiasm than judgment. His labours for the isolation of the Pantheon and the creation of the Museum of Ancient Art and of the Modern Art Gallery in Rome deserved and met with more general approval.

**BACON, HENRY** (1866- ), American architect, was born at Watseka, Ill., Nov. 28 1866. In 1884 he entered the university of Illinois to study architecture, but in the following year began work in the office of Chamberlin & Whidden, in Boston, where he remained three years. From 1888 to 1897 he was with McKim, Mead & White, in New York, excepting the years 1889-91 which he spent in Europe as Rotch Travelling Scholar. From 1897 to 1903 he was a member of the firm of Brité & Bacon, in New York, and thereafter practised alone.

Among his important works were the Court of the Four Seasons at the Panama-Pacific Exposition; the Union Square Savings Bank, New York City; the Public Library, Paterson, N.J.; the Waterbury General Hospital, Waterbury, Conn.; and the Whittemore Memorial Bridge, Naugatuck, Conn. Of numerous monuments, some designed in collaboration with various sculptors, the following should be mentioned: the Lafayette Monument, Brooklyn, N.Y.; the Lincoln Monument, Lincoln, Neb.; the Longfellow Monument, Cambridge, Mass.; the Republic Monument and the Centennial Monument, Chicago, Ill.; the President Harrison Monument, Indianapolis, Ind.; the Civil War Memorial and World War Memorial, Yale University; and the Parnell Monument, Dublin, Ireland. In 1920 the Lincoln Memorial, at Washington, D.C., designed by him, was completed, costing more than \$2,500,000.

**BACON, ROBERT** (1860-1910), American banker, was born in Boston, Mass., July 5 1860. He graduated from Harvard in 1880 (in the class with Theodore Roosevelt), and the following year entered the banking house of Lee, Higginson & Co., in Boston. In 1883 he became a member of the firm of E. Rollins Morse & Bro., and in 1894 joined the house of J. P. Morgan & Co., in New York. After conspicuous success in the financial world he resigned in 1903. He was Assistant Secretary of State, 1905-9, and then for a short time was Secretary of State, succeeding Elihu Root on the latter's election to the Senate. He was ambassador to France from 1909 to 1912. He attended the first Plattsburg Camp and was commissioned major in the U.S. Reserves in 1917, being assigned to the staff of Gen. Pershing with the A.E.F. in France. He returned to America with the rank of colonel, in 1918, and died in New York City, May 29 1919.

**BACTERIOLOGY** (see 3.156).—Since bacteriology is so comparatively young a science, dating, as it does, from the introduction by Koch in 1880 of methods of technique which have made it an exact science, it is not surprising that the decade from 1911 to 1921 saw very considerable additions to our knowledge of the life and functions of the microorganisms with which it is concerned. These additions to knowledge will be reviewed here under two headings: general and agricultural, and medical.

## I. GENERAL AND AGRICULTURAL

*Variations in Bacteria.*—It is probable that nuclear fusion between male and female gametes is essential for the preservation of the special characters of an organism, and that in absence of sex fusion a species will tend to break up into a number of different strains. So far no fusion, either sexual or otherwise, has been observed amongst the bacteria. The characters of bacteria are extraordinarily liable to change according to the conditions of cultivation. Variations in morphology, cultural characters, physiological behaviour, virulence and pathogenicity have constituted one of the most striking features of modern bacteriology. Innumerable instances of such variations have come to light; space will permit of the citation of only a few typical cases.

*Bacillus coli* in the peritoneal cavity in the case of ascites may take the form of a diplococcus; in milk or in urine it may develop into a dense network of branching filaments resembling *B. anthracis*. Again *B. carotovorus*, an organism causing disease in many vegetables, when present in the plant tissue appears as a very small rod; cultivated on artificial media the rods are much larger; in broth it grows in the form of long branching filaments, and in broth containing sublethal doses of antiseptics, e.g. phenol and alcohol, it develops as a minute coccus.

It has recently been shown in separate communications that certain organisms, *B. leptocephalicus* and *B. dysenteriae*, when cultivated on artificial media, segregate each into two distinct types, one forming round colonies, the other diffuse and spreading ones; these types show variations also in agglutinability and in virulence, though otherwise their specific characters are identical. Once separated, the spreading forms in both cases remain true to type, and the question arises whether both strains coexist in the materials taken from the infected animals or whether the spreading forms appear as mutants shortly after removal from the natural habitat. This question can only be answered by investigations of cultures derived from single cells: the finding of segregation of mutants in cultures of this type would be of the greatest interest, but at present such investigations have not been conducted.

The sugar-fermentation reactions upon which much reliance is based in the diagnosis of species are unfortunately very susceptible to change under different cultural conditions; organisms can be "trained" to acquire fermenting powers which they do not normally possess. Strains of *Bacillus carotovorus* isolated from diseased plants grown in different localities were found to possess many various sugar-fermenting powers, but when cultured simultaneously through several transfers under the same conditions and again tested, all gave identical reactions.

All pathogenic organisms rapidly lose the property of virulence when cultivated apart from their hosts, and once lost it is very difficult to restore this character. Virulence is altered rapidly by a change of environment; the attenuation of the anthrax bacillus by cultivation at 40° F. instead of at blood temperature is a well-known phenomenon. Similar rapid reduction in virulence is attained by cultivation of organisms in presence of antiseptics.

One and the same species of an organism may give rise to different symptoms of disease in different individuals. The pathogenicity of *Bacillus anthracis* is considerably altered by exposure to the ultra-violet rays; the symptoms produced on inoculation of the altered strain into an animal are quite unlike the normal symptoms of anthrax. The change which the organism undergoes in the treatment with the ultra-violet rays persists after daily subculture for upwards of two months.

*Transmutation in Bacteria.*—Many experiments have been described wherein bacteria become so changed in character as to suggest that they had undergone transmutation. One must not forget, however, that usually in dealing with cultures of bacteria one has a mixed population, the progeny of several individuals. Even though the culture may be made from a single colony on a plate it is more than probable that such a colony has arisen from a number of organisms herded together. The method of culture of such a population will tend to favour one strain and depress others, so that this strain may eventually be separated and appear as a mutant.

One piece of work, however, which requires confirmation before it can be accepted, should be cited in this connexion. It has been stated in a preliminary communication that *Asotobacter* may give rise to practically every form of organism to be found in the soil. The large round form of *Asotobacter* is said to pass in old cultures into a plasmodial stage from which it may emerge in the various

forms of bacilli, cocci, serotinae, clostridia, etc.; in fact, all the forms common in the soil are held to be only stages in the life cycle of a single species. If this should be confirmed by future investigations, the whole basis of the science of bacteriology will be profoundly modified.

**Industrial Applications of Microbiology.**—In the fermentation industries much use has been made of the variations that can be induced in microorganisms by cultural methods. For example, in the alcoholic fermentation by yeast glycerine figures as a by-product to the extent of some two or three per cent of the sugar fermented; by the addition of sodium sulphite to the fermenting complex the process is profoundly altered and the percentage of glycerine is increased to some 33 per cent. Again, dextrose is converted by *Citromyces* into citric acid, oxalic acid and carbon dioxide; the percentage of citric acid is normally not great, but by high concentration of sugar and low concentration of nitrogenous food it can be raised to 50%. The production of acetone and that of alcohol from maize by biological methods are processes which have been successfully worked during the World War, and encourage one to look forward to considerable developments of microbiology as applied in the factory.

**Bacteria of the Soil: Partial Sterilization.**—Researches at the Rothamsted Experimental Station have proved that soils which have been treated with certain volatile antiseptics or heated to temperatures between 56° and 100° C. show a marked increase in fertility. This results from a parallel increase in the bacterial activity, whereby the rate of the conversion of the organic nitrogenous matter of the soil into nitrogen compounds which are readily available as food for the plant is considerably enhanced. The number of bacteria normally present in soils varies from about 4 to 60 million organisms per gram. Under the above treatment with antiseptics or heat the majority of these are destroyed and the number of active bacteria is reduced to a few hundreds only. By no means all are destroyed, however, since many of the organisms of the soil are of the spore-forming kind and are thus able to withstand the treatment. After the removal of the volatile antiseptics, or after cooling of the soil, the germination of the spores is unhindered and the bacterial population of the soil is quickly reestablished. The treatment renders the soil more suitable as a medium for bacterial growth, so that the number of organisms quickly exceeds by some six or sevenfold the original bacterial content of the soil, or rather that of a control sample of untreated soil kept under the same physical conditions as the treated sample. This remarkable discovery was made in 1909. As a matter of fact it was not an entirely new discovery; reference to the literature showed that the phenomenon had been observed many years earlier by German scientists, but they had curiously failed to grasp the important significance in its relation to the fertility of the soil. Naturally under such drastic treatment the bacterial flora of the soil does not remain unaltered; many species, in fact practically all those which do not form spores, are entirely annihilated. The very important group of ammonia-producing organisms contains, however, very many of the sporing kind, and the increased fertility of the soil is mainly due to the increased production of ammonia. The nitrifying bacteria on the other hand are destroyed, and on the belief, current at that time, that the nitrogen of ammonia had first to be converted into the form of nitrate before it could be utilized by the plant, it was difficult to explain the increase in fertility. It has been shown, however, that this belief had no real foundation but that, in the absence of nitrates, plants can obtain their necessary nitrogen in the form of ammonia and many other of the simpler nitrogenous compounds.

The enrichment of the soil as a medium for bacteria seems to be the result of the removal of an inhibitory factor which militates against bacterial development. This factor is *all probability*, although the hypothesis is not universally accepted, is the protozoal fauna of the soil. On this view, which is supported by the strongest circumstantial evidence, though at the moment direct proof is lacking, the protozoa living mainly upon bacteria keep down the numbers of the latter within the limits stated above, and the removal or depression of the protozoa by partial sterilization results in a corresponding enhancement of bacterial activity.

Methods have recently been developed at Rothamsted by which the members of the different protozoa can be ascertained and, the

interesting fact has come to light that encystment of the protozoa takes place with rhythmic periodicity; certain species investigated pass from the trophic to the resting condition simultaneously every forty-eight hours, a phenomenon which has its parallel in the development of the malarial parasite in the human blood. By counting daily the numbers of protozoa, active and resting, and relating these to the numbers of bacteria in the soil, it has been shown that the bacterial numbers vary inversely with the numbers of the trophic amoebae.

The effect of partial sterilization upon the fertility of the soil is such that it has become a common practice and a paying proposition for the nurserymen in the cucumber- and tomato-forcing industries to sterilize their soils either annually or every second year. The beneficial effect is of rather short duration and in the course of a few years the soil reverts to its former degree of productivity, and in some cases shows, after the initial enhancement, an actual reduction of fertility. These facts are not easily explained on the current hypothesis as set out above. Much attention was being focused upon the subject in 1921, and very interesting results were being obtained by the workers at the Rothamsted station, results which bid fair to revolutionize accepted views, so that the future might well produce a theory more in accordance with the facts.

**Nitrogen.**—It has been recognized for some time that the nitrogen-fixing organisms of the soil are physiologically dependent for their energy upon carbohydrates, and that the amount of atmospheric nitrogen they are able to fix bears a close relationship to the amount of carbohydrate material used up. It was demonstrated in 1915 that the amount of fixation of nitrogen was also influenced by the presence of simple soluble nitrogenous compounds in the soil solution; urea, glycocholl, formamide, etc., had a marked effect in depressing the amount of nitrogen assimilated. These results have been fully confirmed, and it is now known that so long as an available supply of soluble nitrogenous matter is present the organisms will make use of this source in preference to that of free nitrogen, for which a greater expenditure of energy on their part is required.

It is only in recent years that the energy relations of soil bacteria have received due consideration; in 1916 it was pointed out that *Bacillus myodes*, a typical member of the group of ammonifiers, produces ammonia, not as an essential by-product of its metabolism, but rather in virtue of its power of obtaining energy from the protein molecule. If other sources of energy are available, e.g. carbohydrates, these will be drawn upon in preference to the protein molecule with corresponding diminution of ammonia production; in fact, in presence of much carbohydrate the proteins will be entirely neglected and the organism will utilize the ammonia present in the soil as its source of nitrogen, thus competing with the growing crop. Probably most of the bacteria and moulds of the soil are capable under suitable conditions of assimilating ammonia. The process has not been observed in soils poor in organic matter, but in peaty soils it has been demonstrated to the extent of some 50% of the added ammonia.

Obviously then, in the use of farmyard manure, the proper ratio of carbohydrate to protein material is a matter of considerable importance. If the amount of carbohydrate is in large excess, most of the bacterial species will tend to reduce the quantity of nitrates and ammonia already existing in the soil; at the same time under these circumstances, provided the temperature conditions are satisfactory, the nitrogen-fixing organisms will work energetically. The effect will be a temporary depression of fertility, but eventually the nitrogen fixed will become beneficial to the growing plant.

If the material is particularly rich in protein the organisms will produce considerable quantities of ammonia and the effect will be at once beneficial.

If the air supply is insufficient the organisms will tend to produce denitrification, taking some of their oxygen from the nitrates and liberating nitrogen as gas. It has been shown that dressings of farmyard manure may in exceptional cases do more harm than good.

**Symbiotic Nitrogen Fixation.**—At the commencement of the decade the application to the soil of cultures of *Pseudomonas radiciola* was advocated as a means of improving the crops of leguminous plants. As far as the soils of the Old World are concerned hopes of such improvement have been shattered by experience; its soils are already heavily infected with the nodule-producing organism and to inoculate them with any more is merely a case of "bringing coals to Newcastle." In the New World virgin land exists which has never carried leguminous crops; here inoculation with pure cultures of the organism has met with marked success. Although from an economic point of view the study of symbiotic nitrogen fixation has lost much of its interest, in its academic aspects it still retains undiminished fascination. The adaptability of the organism has been further investigated and it has transpired in cross-inoculation experiments that several strains of the organism exist. Based upon trials made by various investigators the nodule organisms are separable into at least nine groups with reference to their power of infection of the various leguminous plants. Thus in one group fall the organisms from all the true clovers, species of *Trifolium*; in a second those from broad bean, peas, vetches, sweet pea, etc.; in a third those of species of *Phaseolus*; while those from soja bean, lupine and locust form each a separate group, no cross inoculations with these having been effected. It is also of great interest to find that on inoculation into animals a reaction occurs, agglutinins being produced which are



specific for the groups as determined by cross-inoculation. By cultural characteristics also the organisms from different legumes show marked differentiation. Three distinct groups can be made with reference to the rate of growth on artificial media, stickiness of the culture and opacity of the colonies. All these facts form perhaps a legitimate basis for the belief that distinct species exist among the nodule-producing bacteria. In numerous other characteristics, however, these organisms are so much alike, and as a whole they differ so widely from any other species of bacteria, that it seems more consistent to regard the adapted forms as varieties of the single species *Pseudomonas radicola*.

Symbiotic nitrogen fixation has been found to occur in plants other than those of the *Leguminosae*; glands in the leaves of species of the *Rubiaceae* and *Myrsinaceae*, which were formerly believed to contain protein crystals, have been shown in reality to consist of colonies of bacteria living symbiotically with the plant cells, receiving their necessary supply of carbohydrates and salts from the surrounding green tissue of the leaves, and in return giving to their nitrogenous by-products to the plant. These organisms have been shown to fix atmospheric nitrogen when grown in artificial culture solutions devoid of any form of combined nitrogen. Their relationship, if any exist, to *Pseudomonas radicola* has not yet been determined. These bacterial glands have been found in a number of plants, including *Pavetta*, *Psychotria*, *Krassia* and *Ardisia*, and seem to be as closely wrapped up with the well-being of the plants as are the root nodules of the *Leguminosae*; the organisms are present in the slime between the young leaves before the opening of the leaf buds, and have been found in the seed between the scutellum and the embryo. Their introduction to the seed takes place at the time of fertilization, the pollen tube conveying them from the stigma to the ovule. The infection of the leaves occurs immediately after the opening of the buds, the ordinary water pores of the leaf usually functioning as the ports of entry. In the cases of *Pavetta* and *Psychotria*, however, where the glands appear on the lamina of the leaf, a special stoma has been described as an extraordinary adaptation of the plant for the reception of the bacteria. This pore is of exceptional size as compared with the ordinary stomata of the leaf, and is said to be filled in by growth of the surrounding tissue after its function has been fulfilled.

The benefit derived by the host plants from the presence of their guests has been clearly demonstrated by seedlings raised from bacteria-free seed—obtained by careful hot-water treatment of the seed—in sterile and inoculated sand cultures fertilized with potash and phosphorus but no nitrogen compounds. The plants grown in the inoculated cultures flourished and possessed typically green leaves, while those in the sterile sand showed all the signs of nitrogen starvation and soon died off.

**Cellulose Fermentation.**—The classical investigations of Omelianski showed that the cellulose of plant remains was decomposed under anaerobic conditions giving rise to marsh gas and hydrogen. This knowledge, however, does not help towards an explanation of the rapid destruction of plant residues in ordinary cultivated soils where conditions are mainly aerobic. It is well recognized that the looser the soil the more rapid is the destruction of carbohydrate material. It is generally supposed that fungi play an important part in these processes and many species of moulds and actinomycetes have been shown to possess the power of attacking cellulose. The American workers have invented cellulose media upon which bacteria can be cultivated, and have succeeded in isolating several species, *Bacillus rossica*, *B. Amylolyticus*, *Bacterium flavigena* and some fifteen others which are capable of using pure cellulose as their only source of carbon. All these organisms are morphologically and physiologically distinct from Omelianski's hydrogen and methane organisms and grow well on ordinary gelatine media. The most powerful oxidizer of cellulose, however, is an organism discovered at Rothamsted in 1919. It is a peculiar organism exhibiting two distinct morphological characters at different stages in its life history, a long sinuous thread-like form and a large round "sporoid" form; it seems rather to be related to the spirochaetes than to the true bacteria and has received the name *Spirochaeta cytophaga*. It is an obligate aerobic and rapidly attacks cellulose, though it has no power of fermenting other carbohydrates; in fact, the presence of sugars, especially of the reducing sugars, strongly inhibits its action upon cellulose. Like the nitrifying bacteria it cannot be cultivated upon ordinary nutrient media containing proteins, 0.25% of peptone being sufficient to prevent growth. The products of decomposition of cellulose consist of a mucilaginous substance, small quantities of fatty acids and a yellow pigment allied to carotin. The discovery of this organism helped materially towards the production of an artificial substitute for farmyard manure, a great achievement in these days when motor traction has so reduced the available supply of this universal fertilizer. Moreover, the substitute has a considerable advantage over the natural product since the carbon-nitrogen ratio can be perfectly controlled.

**Sulphur and Phosphorus Cycles.**—Considerable attention has recently been paid to the conversion of the sulphur and phosphorus present in the proteins of plant and animal residues in the soil; by series of bacterial reactions, forming complete cycles, these elements pass from their combination in the protein molecule into the forms of sulphates and phosphates, and so become taken up and,

once more, elaborated into the organic constitution of the plant. It has long been assumed that the supply of sulphates in all soils was sufficient for the optimum growth of crops. This assumption was based upon the low sulphur content of plant ash; recent investigations have shown, however, that as much as 90% of the sulphur of the plant may be lost in the process of ignition. The amount of sulphur removed by the crop from the soil is now a factor to be considered, and it has been shown experimentally that sulphur may become the limiting factor for crop production.

Further, the sulphur and phosphorus relations in the soil are considered to be interrelated to the extent that the insoluble rock phosphate is rendered soluble by the action of sulphuric acid produced in the oxidation by bacteria of the hydrogen sulphide from decomposing proteins. Pot experiments have shown that the application of sulphur as a fertilizer together with rock phosphate tends to increase the availability of the phosphate: the evidence at present, however, is insufficient to show whether any material profit is to be gained by this method of fertilization.

**Sewage Disposal.**—The purification of sewage by the aerobic bacteria which are normally contained in it is so slow, requiring many days for completion, that sewage disposal by this means alone has long been regarded as impracticable. A method of hastening the process was, however, discovered in 1913, and since 1916 the "Activated Sludge Process" has actually been in successful operation. When sewage is well aerated the colloidal suspended matter gradually disappears, being acted upon by aerobic bacteria, and gives place to a granular brown mass which rapidly settles, leaving a clear solution of the inorganic salts, such as chlorides and nitrates, with only quite small amounts of soluble organic matter. It was discovered that this brown sediment added to a fresh supply of sewage and aerated by a blast of very fine air bubbles considerably hastens the oxidation process. On repetition, each increase in the amount of the sediment in relation to the volume of sewage is accompanied by an increase in the rate of oxidation, so that, when the relative amount of sediment approaches 40% of the total volume, oxidation is complete in the space of a few hours. This brown sediment forms the so-called "activated sludge," and consists very largely of a mass of living organisms, bacteria and protozoa.

In practice two tanks are employed: (1) the aeration tank in which the sewage and activated sludge are blown with air forced through porous material so that it reaches the sewage in a finely divided state, and (2) the settling tank in which the sludge is deposited and from which an effluent requiring no filtration is run away. Any excess of sludge over and above that required to maintain the necessary quantity of 25% to 30% in the aeration tank is spread out to dry by evaporation and forms a valuable soil fertilizer.

The percentage of nitrogen in the activated sludge is considerably higher than that of the sludge from the sedimentation and septic tanks of the older and more usually employed method of sewage treatment. The results obtained from the activated sludge process in operation at Manchester show a yield of nitrogen per annum approximately equal to the total faecal nitrogen of the sewage treated, whereas in the older method much of this and all the urine nitrogen passes away in the effluent in the form of nitrates.

It has been stated that fixation of atmospheric nitrogen actually occurs in the process; from what is now known of the energy relations of the nitrogen-fixing bacteria, however, any considerable amount of nitrogen fixation in a medium where the quantity of soluble nitrogenous compounds is large in relation to the quantity of carbohydrate material seems very doubtful. It is more probable that the conservation of nitrogen results from the fixation of ammonia which in the older process of sewage disposal becomes converted into soluble nitrates.

As at present produced the amount of nitrogen in the dry sludge is about seven per cent. If by any means this can be increased to about 10% and if economical methods of drying the sludge can be found there is a great commercial future for the process. As it is, and was, a great waste of water in the activated sludge process something like a million gallons of sewage are treated daily, the fruit growers take away the sludge in a semi-dry condition and pay about 30s. a ton for it as it lies on the works.

**Bacteriosis in Plants.**—The study of bacteria in relation to plant diseases may be said to have been in its infancy in 1910. At that time—mainly through the researches of American bacteriologists—it had been shown that bacteria could enter healthy plants through wounds and stomata and produce epidemics of disease so serious in nature that the crops over wide areas were partially, and in some instances entirely, destroyed. The subsequent decade saw considerable activity in the field of plant pathology, and the pathogenicity of certain bacteria for plants has been fully established. In fact the number of species of bacteria now known to produce disease in plants is rapidly approaching that of the human pathogens.

In comparing the disease-producing organisms in animals and plants one finds bacilli freely represented in both groups, but whereas the coccid types, *Streptococcus*, *Micrococcus* and *Staphylococcus*, are frequently responsible for disease in animals, they have so far never been found to be associated with a disease in plants; on the other hand the genus *Pseudomonas* of Miquela is strongly represented amongst the plant pathogens while having no place, so far as is known, amongst the organisms pathogenic for

man and animals. No explanation for these interesting morphological differences has hitherto been advanced, and if any significance is to be attached to them it has yet to be discovered.

Exactly what it is that constitutes virulence in an organism and makes the distinction between parasitic and saprophytic forms is entirely unknown. One naturally asks whether an organism may possess virulence for both plants and animals: so far as experience goes this seems not to be the case; one may perhaps as the result of eating bacterially diseased fruits experience a temporary disturbance of the alimentary system, but nothing of a more serious nature need be feared. On the face of it such a phenomenon as a general occurrence would seem to be unlikely from the fact that the reaction of the medium in the two cases is very different; an organism which is favoured by the alkalinity of the animal serum can hardly be expected to grow strongly in the sap of a plant where the reaction is often strongly acid, and *vice versa*. On the injection of plant parasites into laboratory animals nothing more than a slight local disturbance—an abscess—results or occasionally the animal may show a disinclination to move and take food, a malaise for a brief period from which it quickly recovers. In the serum of such inoculated animals antibodies, specific agglutinins, are produced but this probably has nothing whatever to do with virulence since it follows also upon the injection of the common saprophytes.

The effects of bacteria upon the attacked plant are by no means so helpful towards a diagnosis of the disease as are the effects of bacteria upon the human being. The specific symptoms of disease in man by which the general practitioner is enabled to diagnose his case with more or less certainty, although he may have only a rudimentary knowledge of bacteriological technique, have no counterpart in the diseases of plants. The plant pathologist must first isolate and identify the causal organism, often a task of considerable difficulty, before he can arrive at a true diagnosis, the symptoms of disease produced by a number of different organisms being almost exactly similar. According to these group symptoms the bacterial diseases of plants may be divided into four main types, namely: *Soft Rots, Wilts, Intumescences and Local Lesions*.

**Soft Rots.**—The plants most attacked by rot-producing organisms are the root vegetables and potatoes. A certain amount of disease may occur while the plants are still in the ground, but the greatest losses take place during storage of the roots through winter. The rot results through the solution of the cementing substance, the middle lamella, which holds the cells of the plant tissue together just as mortar holds together the bricks in a building. This cementing substance consists of pectin material and its solution is effected through the agency of an enzyme, a pectinase, produced by the bacteria. The removal of this substance causes the tissue to lose all coherence and the cells to become reduced to a wet pulpy mass. Diseases of this type are the "White Rot" of turnips, the "Soft Rot" of carrots and other vegetables, the "Heart Rot" of celery, and the "Blackleg" of potatoes.

**Wilts.**—A number of very destructive diseases is included under this head. The symptoms are almost identical in all cases and are the result of the blocking up of the conducting system of the plant by bacterial growth in the vessels, so that those parts of the plant, whose natural supply of watery sap is thereby cut off, die from wilting, and become the prey of all kinds of bacteria from the soil and air, and finally either dry up or become reduced to a wet rotting mass. Other symptoms are striping of the leaves, a general dwarfing of the attacked plants, and a one-sided growth of the plants resulting from a one-sided localization of the infection. The striping of the leaves is due to pigments, either in the bacteria themselves or in the wood of the invaded vessels, making the course of these vessels apparent from the outside as streaks usually of a yellow, red, or brown colour.

Many of these wilts are caused by organisms which are extraordinarily similar in many of their characters. They belong to the genus *Pseudomonas*, are strongly yellow in colour and are indistinguishable under the microscope. They might be considered to be only varying strains of one and the same species except that they show constant differences in degree of pigmentation and in certain of their physiological characters; moreover they seem to be quite specific for the diseases in the plants or orders of plants in which they have been found, and all attempts to produce disease in one kind of host by inoculation with the specific organism of disease in another kind have so far been quite unsuccessful.

Included in this group of diseases are the very troublesome "Black Rot" of cabbage and other members of the family *Brassicæ*; Wakker's disease of hyacinths, which has been responsible for the entire disappearance of some of the most beautiful varieties of hyacinths from the beds of the Netherlands with serious financial loss to the Dutch growers; and a disease of sugar-cane known as Cobb's disease which produces heavy losses in seedling canes and also much difficulty and loss in extraction of the sugar by reason of the gummy slime which the bacteria produce, causing trouble in the crushing machinery and in the evaporating pans. Other serious wilt diseases are the wilt of cucumbers, the wilt of tomatoes, potatoes and other solanaceous plants, including tobacco whose cultivation in parts of Malaya and other districts has had to be entirely abandoned as the result of this disease.

**Intumescence Diseases.**—Here the disease takes the form of large warty or pseudo-cancerous growths on the stems and leaves of the attacked plant caused by hypertrophy of the cortical tissues and mesophyll under the irritating stimulus of the presence of the invading organism. Crown Gall, a destructive disease of roses, grapes, vines, hops and a large number of other hosts, belongs here. In this case the trouble is largely confined to the crown of the root where it extends from year to year, eventually growing to such a size that death of the tree results through destruction of the conducting tissue of the root. Another disease of this type is the Olive Knot, a well-known pest wherever olives are in cultivation.

**Local Lesions.**—Local lesions or cankers result through destruction of the external tissues of plants in localized areas upon the stems, leaves and fruits. Stripe disease of tomatoes is well known to growers in Great Britain; the Citrus canker is a serious disease in S. Africa and S. Florida, and in the tropics generally Leaf Spot diseases of beans and of cotton have been shown to be caused by bacterial parasites.

**Control Measures.**—At present there is no means of control for bacterial diseases in plants which can be of general application. Obviously the prophylactic and curative methods of injection so successfully used against disease in animals cannot be of use for plants. The use of sprays which are often most effective against fungal diseases of plants is of no avail against the bacterial ones. Sterilization of the soil might be of service against such parasites as are infective of the plant through the soil, but it is clear that, in order to kill the parasitic form, one would at the same time necessarily interfere with the normal soil flora upon the functions of which the fertility of the soil depends.

In certain instances where the disease is carried by some biting insect, attack upon this carrier has resulted in more or less successful control. A case in point is that of the wilt of cucumbers, where the organism is introduced on the mandibles of a beetle. In this case it is found that the beetle has a special predilection for the wild squash, and by growing these in drills between the rows of cucumbers almost all the beetles can be collected upon them, where they can be periodically annihilated by spraying with kerosene. Another means of control is found in the manual treatment of the soil whereby a more hardy and resistant plant is produced. In this way by the increase of potash it has been possible to effect a considerable reduction of the Stripe disease in tomatoes. The rotation of crops, so that several years elapse before a crop which has been diseased is again grown on the infected soil, is for the majority of bacterial diseases the only means of control known at the present time. In this way the parasite, not finding its particular host for some time, may die out or may become so altered physiologically as no longer to possess the power of attack upon the plant.

REFERENCES.—Gurney-Dixon, *Transmutations of Bacteria*; J. A. Arkwright, "Variation in Bacteria in Relation to Agglutination both by Salts and by Specific Serum," *Jour. Path. and Bact.* (1921); F. H. De Kruijff, "Dissociation of Microbe Species," *Jour. Amer. Med. Assn.* (1921); E. J. Russell, *Soil Conditions and Plant Growth*; *Journal of Agricultural Research*; *Journal of Agricultural Science*; G. J. Fowler, "The Conservation of Nitrogen with Special Reference to Activated Sludge," *Journal of the Indian Institute of Science* (1920); E. F. Smith, *Bacteria in Relation to Plant Diseases*; E. F. Smith, *Bacterial Diseases of Plants*; *Phytopathology*; *Annals of Applied Biology*; *Bulletins of Experimental Stations*, U. S. A. (S. G. P.)

## II. MEDICAL BACTERIOLOGY

It has been more and more recognized by the epidemiologist that one of the chief structural units in the bridge which connects one outbreak of a disease with another is the carrier. By the term "carrier" is meant an individual who, though healthy and thus unsuspected of infectivity, still harbours in his body pathogenic bacteria which, passed in the various excretions, constitute, when given favouring circumstances, a danger to those about him. These favouring circumstances may be withheld for long periods, but the individual, on the other hand, may continue to conserve and distribute the microorganisms for still longer periods—even many years.

**Disease Carriers.**—A certain number of bacteria pathogenic to man find carriers among animals, for instance the virus of Malta fever, which multiplies and is distributed in the milk of infected goats, but mainly man is himself responsible.

The carrier may be a person who has survived an attack of the disease in question and failed to rid himself of the causative organisms, which, lodging themselves in the respiratory, genito-urinary or intestinal tract, continue an existence such as do the saprophytic organisms normally found in those regions. He may, on the other hand, be an individual who entertains the bacterium without ever having displayed any symptoms of the disease. A chain of such carriers, recording no history of illness, but passing on the virus in secret, as it were, would be the explanation of sporadic cases, say, of cerebrospinal meningitis, occurring in non-epidemic times, at

widely distant and apparently unrelated places. In the same way, the seeds of a disease may be conserved over long periods from one epidemic to another.

That the carrying of pathogenic bacteria by either man or animals, together with the opportunity of their transmission to others, does not altogether explain the spread of disease is certain. A loss of virulence on the part of the virus or an acquisition of immunity by the population, or both of these occurrences, must be assumed to explain the gradual spontaneous termination of an outbreak, and, similarly, the converse of those phenomena must be regarded as playing a large part in the recrudescence of an epidemic.

The laws governing the loss or gain of virulence by bacteria are very imperfectly understood; even in the laboratory pathogenicity is largely beyond control; elsewhere it is entirely so. The two other factors concerned in the spread of disease are less elusive. Even though the carrier state is one which has so far shown itself recalcitrant to treatment, carriers can be, if circumstances warrant such a drastic step, segregated, kept under observation, and finally recommended to adopt a course of life not likely to favour infection of others. To hasten or forestall the immunity assumed to occur in a community during the course of an epidemic is the object of prophylactic inoculation, a procedure of which the success has been further demonstrated during the World War.

**Prophylactic Inoculation.**—The compound anti-enteric vaccine, which includes all three typhoidal germs, *B. typhosus*, *B. paratyphosus A and B*, was universally employed in the British armies and was attended by excellent results, as witnessed by the following statistics.

Typhoid cases in the British Expeditionary Forces in France up to May 1915 numbered 827. It was found that the incidence was 14 times and the mortality 42 times greater among the uninoculated than among the inoculated; up to August 1916 508 uninoculated had a case mortality of 23.4%, while 906 inoculated had one of 5.2%. Similar good results attended the use of anti-typhoid vaccine in the armies of other belligerents. It clearly reduced the total number of cases and lowered the mortality rate. Only in Germany was doubt cast by any appreciable number of scientific workers on the efficacy of prophylactic inoculation. A small body of opinion there considers that only by the use of a living virus, as in smallpox vaccination, can a reasonable immunity be conferred. It has been suggested by their critics that the Kollé vaccine, which is used in Germany, is of inferior immunising power, and certain pre-war statistics, comparing the use of this vaccine with one prepared by Vincent's method, bear this criticism out.

Other prophylactic vaccines, the use of which has been attended more or less definitely by success, are those directed against cholera, plague, pneumonia, cerebrospinal meningitis and influenza. Tentatively used, because of its great toxicity, is anti-dysentery vaccine.

**Vaccine Therapy.**—Other therapeutic employment of bacterial vaccines has been extensively adopted and has, according to some workers, justified itself in such widely different diseases as furunculosis, rheumatoid arthritis and whooping-cough. Much work without, unfortunately, corresponding success continues to be done with vaccine therapy in tuberculosis. It was hoped at one time that the administration of vaccines might be controlled by observations of the opsonic index, made during treatment, but the method has been discarded as not capable of furnishing a reliable guide to dosage, as was expected of it.

**Serum Therapy.**—Treatment by inoculation with serum specific for the disease in question has made notable advances. Besides those long in use in diphtheria, tetanus and streptococcus infections, sera capable of neutralizing the toxins produced by *B. welchii*, *B. oedematis* and *V. septique*, all these gas-gangrene bacilli, are now prepared. The efficiency of anti-meningococcus serum has been greatly increased by the recently acquired knowledge of the physiology of the meningococcus and by improvements in the manufacture of anti-toxin. Thus it was possible, by the use of more effective sera together with more rapid diagnosis generally, to lower the death-rate for cerebrospinal meningitis in the home forces from 65% in 1914 to 35% in 1918, and even to less than 10% where the infection was due to that strain of the meningococcus known as Type I.; it is against this type that the most potent anti-toxin is preparable. Other sera the use of which has been attended by favourable results are those directed against dysentery and pneumonia.

**Anaphylaxis.**—In connexion with the administration of animal sera, the phenomenon of anaphylaxis has to be recognized. In animals this condition results after repeated inoculation with a protein foreign to the animal injected. A guinea-pig, for instance, if inoculated with even a very small quantity of, say, horse serum and then after at least five days reinoculated with the same type of protein, can in some cases suffer so severely that death ensues within a few minutes, and this although the total amount of protein administered on both occasions is very much less than that which could with perfect safety have been given on the first occasion. The first inoculation is regarded as rendering the animal "sensitive" to the particular protein employed and may, for an animal like a guinea-pig, be as little as 0.0005 of a milligramme. The second inoculation of 0.1 to 0.5 of a milligramme occasions the anaphylactic shock which consists for the main part of convulsions, paralysis and cessation of respiration. The causative agent has been considered

to be a poison formed by the union of the antibodies, produced in the animal by the first inoculation, with the antigen (the protein) inoculated on the second occasion and has been called anaphylatoxin. A surprising feature is that, no matter what protein be employed, the symptoms are in all cases similar. It is for this reason that other investigators have thought anaphylaxis to be not a toxic but a colloidal phenomenon, in which after the second inoculation an extremely minute precipitation, a gel phase, occurs in the body, occasioning in the lungs mechanical interference with oxygen absorption.

In man anaphylaxis is not so pronounced as in some animals, for instance rabbits and guinea-pigs, yet the danger is sufficiently grave to demand special care during serum treatment.

It has been found in animal experiments that if the second inoculation of protein is survived, the anaphylactic condition disappears. In serum therapy, therefore, if any anaphylaxis is to be feared, a very small "desensitizing" inoculation is given before proceeding to the injection of the full amount. The anaphylactic state is met with in persons who have, on some previous occasion, had serum administered to them, or, more usually, it is encountered as a natural condition, as for instance in those individuals who show susceptibility to some particular foodstuff, such as white of egg.

**Anaerobes and Gas Gangrene.**—A group of bacteria which the World War threw into great prominence is that of the anaerobes. A wide divergence exists among microorganisms as to the oxygen pressure under which growth is possible. The anaerobes require that oxygen be absent, or present in but minute quantities, in their environment. The group is found widespread in nature; its chief breeding-ground being the intestinal tract of man and animals, distribution proceeds for the most part along with the manuring of the fields.

The importance of the group from a human point of view lies in the high toxicity possessed by several of its members. Its more special importance during the war lay in the fact that wounds inflicted by explosive force are usually extensive and earth-soiled, this in such highly cultivated lands as those of Flanders giving an opportunity for infection by anaerobes and for the subsequent development of the very fatal gas gangrene that was, particularly in the first months of the war, such a frequent wound complication.

Knowledge of the anaerobes has been, until the last few years of intenser French, English and American work, in a chaotic condition, only *B. botulinus*, which occasions food-poisoning, and the bacillus of tetanus having been at all accurately studied and described. Of the remaining anaerobes little was known with certainty; accounts were contradictory owing to non-recognition of the fact that the cultures with which work was carried out were not pure. In this way, besides there being great confusion in nomenclature, the group acquired an undeserved reputation for remarkable variability; it was recorded how one species melted into another with the mere alteration of the media on which it was grown and the result was ascribed to an inconsistency of species. In reality, it was a second strain, long dormant in the impure culture, which was now, owing to a more congenial environment, able to assert itself.

The usual bacteriological methods for the establishment of pure cultures which hold good in the case of aerobes are unreliable when applied to the anaerobes, which appear to possess a special property of not readily growing, unless associated in some numbers. For this reason, the anaerobic cultures which "take" are far more likely to be impure, and the concealed impurity may pass undetected through a whole series of sub-cultures.

A more refined technique and a more meticulous criticism of results proved necessary and were applied during later investigations.

In the group of spore-bearing anaerobic organisms concerned with wound infections and apart from *B. tetanus* already well studied, in spite of the fact that it also existed mainly in impure culture in the laboratories, three outstanding pathogenic species have been set up:—

(1) *B. welchii*, the most frequently found of the gas-gangrene bacilli, previously described under a variety of names and in various conditions of impurity as *B. aerogenes capsulatus*, *B. phlegmonis emphysematosa*, *B. perfringens*, *B. enteritidis sporogenes*; (2) *Vibrio septique* (Pasteur), the *B. oedematis maligni* of Koch, and (3) *B. oedematis*, a highly toxic organism discovered by Weinberg and Seguin in 1915.

For all three, potent antitoxic sera have been prepared and the treatment of cases has been greatly improved by their use. Certain slightly pathogenic anaerobes such as *B. histolyticus* are also concerned in the polymicrobial invasion of wounds, as well as a series of definitely non-pathogenic anaerobes, like *B. sporogenes*. Some of these may symbiotically assist infection; others appear only in the rôles of contaminating organisms, taking no part in the morbid processes.

**Epidemic Influenza.**—To our knowledge of the aetiology of influenza the last world-wide epidemic of 1918, with its enormous incidence and with its appalling mortality, returns, such as that of six millions for India alone, has brought but an increase of uncertainty. Discovered by Pfeiffer in 1892, the *B. influenzae* was, up till 1918, widely accepted as the cause of that disease. But the failure, during the last pandemic, of a large number of bacteriologists

to isolate the bacillus from a considerable proportion of the cases investigated, together with the fact that the disease could not be experimentally passed on to either man or animals by inoculation with Pfeiffer's bacillus, caused a revolt from the orthodox belief. It is considered by many that the primary aetiological factor still remains undiscovered and that the *B. influenzae*, like the *Streptococcus* and the *Pneumococcus* (the three pathogenic microorganisms most usually found associated with the disease), is but a secondary invader of the tissues, and even though of such malignancy as to be frequently the occasion of the fatal termination, still not the original *causa causans*. Owing to their negative findings, a large number of bacteriologists have concluded that this must be placed in the ever-growing ranks of the still more invisible viruses, organisms so minute that even with the aid of the ultra-microscope they are not or barely to be seen; of so diminutive a size that they are capable of passing through the pores of even the finest porcelain filters. An accepted instance of such a deposition of an organism from the position of causative agent to that of a mere secondary invader may be found in the case of *B. suispestifer* in the disease hog cholera. The true virus here has been demonstrated to be a filter-passer.

From many parts of the world came reports of the proof of such theories of a filtrable virus in influenza, but in no case have they stood the test of criticism. With regard to the tiny globoid bodies shown in the filtered fluids, no evidence of their true influenzal nature from an infective point of view was forthcoming. They have been considered to be inanimate particles of disintegrating protein or even ordinary contaminating bacteria gaining access to the culture tubes through a faulty technique.

Those investigators who resent the attack on the orthodox belief in the *B. influenzae* as an aetiological factor point out that not all workers failed to find that organism in their cases; that those employing more satisfactory media for the growth of the bacillus were able to isolate it in as many as 90%. They further point out that an illness recognizable as influenza has not so far been transferable to ordinary experimental animals. That man is not infected by inoculations with living *B. influenzae* is, they hold, discounted by the observation that it has not been possible voluntarily to transmit the disease from one person to another, even by such drastic methods as the swabbing of the mucous membranes with the inflammatory secretions taken from the eyes, nose and throat of pronounced cases.

This paradoxical indication of a low infectivity of influenza is qualified by the fact that the experiments have been carried out during and subsequent to the pandemic, when persons chosen for the experiment as normal, because of their not having succumbed to an attack of the disease, may be regarded on those very grounds as possessing a considerable degree of natural immunity, and therefore as not being acceptable as normal at all. More recently, experimental infection of both monkeys and man with influenza bacilli and the production of acute respiratory disease have been demonstrated, but the identity of the illness evoked with that of epidemic influenza is far from established. The whole question of the aetiology of influenza is still *sub judice*.

**A New Paratyphoid.**—Early in the war, in a number of the armies engaged in the Near East, an illness was noticed which, although it corresponded clinically in many ways with enteric, did not yield a virus agreeing with any of the three well-known organisms of that group of diseases—*B. typhosus*, *B. paratyphosus A* or *B*—though culturally it was identical with the last-named. The bacillus that was isolated by Hirschfeld from cases occurring in the Serbian army was called by him *B. paratyphosus C*, and included in the anti-enteric vaccine used in the Serbian forces. Neukirch, recording recognition of it earlier on the Turkish front, gave it the name of *B. Erindjian*. As the organism agrees culturally with and is serologically related to *B. paratyphosus B*, it has been suggested by others that it should, for simplicity's sake, be regarded as one of the many paratyphoid B types. Some workers have insisted on the identity of this so-called paratyphoid C with the bacillus found in pigs suffering from swine fever and called variously *B. suispestifer*, *B. of hog cholera*, and *B. Voldagen*, but, though the relationship is very close, identity does not seem to have been proved. This newly recognized type of paratyphoid B, apparently in the main of Eastern habitat, has no doubt often in the past masqueraded as an atypical or inagglutinable paratyphoid bacillus.

**Typhus Fever.**—Another disease that sprang into special prominence during the war, and the aetiology of which has received considerable elucidation, is typhus. Nicolle and his collaborators first gave experimental proof of the transmission of typhus to monkeys by the body louse. In the case of man such laboratory demonstration has, however, because of the severity of the disease, been mainly accidental and therefore incomplete. But while there are other theories of supplementary means of infection, such as that it is air-borne or transmitted by droplet infection, evidence that the louse is the only carrier or communicator of typhus has accumulated to a great extent. The sole measure for the successful combating of an epidemic has been a de-lousing campaign. The effect of good ventilation in preventing infection spreading from patients in a ward, at first regarded as a proof of its air-borne nature, can now be explained by the fact that lowered temperatures are inimical to the activities of lice. In cool, well-ventilated rooms these vermin will refrain from leaving the bodies of their hosts, and should they be

driven to do so by the high temperature of a very feverish case or the lowered one of a corpse, they will be handicapped in their search for a new host. Against the complicity of other insects, such as the flea and the bed-bug, there are the observations that typhus is contracted only after close contact, which for flea-borne diseases is not necessarily the case; while, did the bed-bug play a part in infection, typhus would be a house disease and not one transmitted for the main part through the agency of lice-ridden clothes.

In 1910 Ricketts and Wilder described very small bodies seen in the gut of lice taken from typhus patients. In 1916 Rocha Lima repeated the observation. He regarded them as protozoal in nature and classified them as chlamydozoa. The chlamydozoa are organisms more minute than bacteria, consisting at one stage of but a speck of chromatin with no cytoplasm or membrane of any kind. At some period of their life-cycle they are filterable. The viruses of rabies, poliomyelitis, scarlet fever and vaccinia have among others been regarded as belonging to the chlamydozoa. The form seen in typhus lice was called by Rocha Lima *Rickettsia prowazeki*, to commemorate two workers who had succumbed to typhus infection during their investigations; Ricketts being also, in 1909, the first to describe bodies of this nature in the ticks which transmit the disease known as Rocky Mountain fever. The aetiological relationship of these bodies to typhus is being generally recognized. The criticism that similar bodies have been found where no typhus existed has been countered by the discovery that a different species, the *Rickettsia quintana*, is associated with the disease trench fever, and the assumption that, as there are a variety of *Rickettsia*, some may well be apathogenic for man. Belief in the causative nature of such bacilli as that of *Plote* and the *Proteus X 10* of Weil and Felix now finds little support. Indeed, when lice are fed with the latter organism, they die within the period it takes a louse to become infective after it has had access to a typhus patient. The defenders of a filtrable virus as the infecting agent are met by the fact that some forms of *Rickettsia* have been described of so small a size that their passage through a filter fine enough to retain bacteria would be possible.

**Trench Fever.**—In 1916 Töpfer recorded the occurrence of *Rickettsia* bodies in the blood of and in lice taken from individuals suffering from what has in different countries been called trench or Volhynian fever. The justification for the association of this *Rickettsia quintana* or *Volhynia* with the febrile disease rests on much the same kind of evidence as that furnished in the case of typhus; but here experimental work on man has been possible, and Arkwright, Bacot and Duncan have definitely proved the infectivity of the *Rickettsia*-containing lice and their excreta for human beings.

**Yellow Fever and Infectious Jaundice.**—A great deal of enlightening work was carried out on yellow fever during 1919-21 by the Japanese research worker Noguchi, of the Rockefeller Institute. Previous to his investigations most of our knowledge of the aetiological factors in this most dreaded of tropical diseases rested on the courageous work with its attendant loss of human life performed by the American Yellow Fever Commission in 1900. It was then established that yellow fever was an insect-borne disease, the vector being the mosquito *Stegomyia calopus*. Many other data concerning the incubation period of the disease and the life-cycle of the virus, which was shown to be filterable, were also established. But the causal agent was neither isolated nor seen. It remained for Noguchi to detect in yellow-fever cases a spirochaete, an organism of similar nature to the specific agent of syphilis, a protozoan, and to prove, short of reproduction of the disease in man, its aetiological relationship to yellow fever. This organism he named *Leptospira icteroides*. He found it to be very closely related to, though not identical with, the leptospira discovered independently by Inada and Ido in Japan and by Uhlenhuth and Fromme in Germany in cases of infective jaundice or Weil's disease. This latter organism has for hosts both rats and mice, and has been named *L. icterohaemorrhagiae*; an anti-serum is made with the leptospira of infectious jaundice and possesses considerable curative value. Noguchi's reports on anti-yellow fever inoculation are only just beginning to appear but already show favourable results.

**Wassermann Test.**—Among laboratory diagnostic methods of a serological character, the Wassermann test for the detection of syphilitic infection still maintains its position of prominence. The reaction, which is a complicated one, declares itself as positive or negative by the power the patient's serum has or has not of going into combination with guinea-pig complement and an extract of animal tissues. This was at first regarded as an immunity reaction, involving the usual antigen, anti-body and complement, with the *Spirochaeta pallida* (the virus of syphilis) acting as antigen. But it is now known that that organism does not play a part at all in the test, which is considered to be an interaction between lipid bodies (in the tissue extract), anti-lipoid bodies (present in syphilitic sera owing to the abnormal production of lipids during the course of the disease) and complement (guinea-pig serum). Many modifications of the original Wassermann reaction are in use, mainly characterized by increased complexity of technique, but the new diagnostic method of Sacha and Georgi is comparatively simple, consisting merely of interaction between the patient's serum and a lipid solution; it is apparently of satisfactory reliability.

**Agglutination Test.**—A serological test which has undergone some development in recent years is that of agglutination. It has become more necessary to distinguish between specific and group agglutination. When an agglutinating serum has been prepared by inoculating an animal with one species of bacteria, it is found that the serum is capable, not only of agglutinating that species to a high degree (specific agglutination), but also frequently of agglutinating other closely related species (group or co-agglutination), and this sometimes to practically the same extent as it does the homologous species. Further, it has been observed that an organism isolated from an individual infected with some other quite alien, bacterial species will have acquired, more or less temporarily, the property of agglutinating with serum specific to that alien infecting species. This is called paraggglutination. Perhaps the most striking case of paraggglutination is that of a certain strain of *B. proteus*, named by its discoverers X70, and isolated by them from cases of typhus. Here an organism, well known as an agent of bacterial decomposition and of some virulence for the human body, though productive of no symptoms comparable with those of typhus and believed not to participate in that disease at all, has acquired the property of agglutinating with the serum of individuals who have contracted typhus. This it does to so marked a degree that the paraggglutination has actually been used as a means of diagnosing the illness, far removed from one another though *B. proteus* and the causal agent of typhus are in the scale of living organisms. And in this case, the paraggglutinating character has been seen to be more than a temporary acquisition.

**Absorption Test.**—To distinguish between specific and non-specific or group agglutination, a modification of the agglutination test is employed—the absorption test. It is found that, after complete absorption of a serum with its own specific species, all agglutinins have been removed. When a co-agglutinating species is employed only the group agglutinins will be absorbed, the specific agglutinins remaining intact. By this means it has been possible to discriminate between closely related strains and to divide species into a variety of types. This has been notably the case with the pneumococcus, the meningococcus, the dysentery and paratyphoid B groups. The recognition of the existence of different types of pneumococci and meningococci has proved of great importance for diagnostic, prophylactic and therapeutic reasons. In the case of prophylactic inoculation against pneumonia, as carried out so extensively by Lister on South African miners, it was seen to be very essential that the types predominant should be outstandingly represented in the vaccine used. In the serum therapy of both pneumonia and cerebrospinal meningitis cases it is necessary for the best result that the type of pneumococcus and meningococcus concerned should be known and a corresponding anti-serum administered. When dealing with *B. tetanus*, on the other hand, the importance of distinguishing between the various agglutinating and absorptive types does not maintain; an identical toxic element appears to be common to them all, so that one anti-toxin serves for whatever type may be responsible for the infection.

**Schick Test.**—Valuable aid in combating diphtheria epidemics is afforded by the Schick test. This supplies a criterion of the immunity an individual possesses against infection by the diphtheria bacillus and is carried out by the injection of a small quantity of diphtheria toxin into the skin of the person tested. If the individual possesses immunity the toxin is neutralized and no reaction in the tissues takes place; if there is no immunity the toxin, by irritation of the skin, sets up a small inflammatory condition which is easily recognizable. The practical application of this measure lies in the possibility thus afforded of discovering, in, say, a school or other large body of people who are running the risk of diphtheria infection, which individuals possess no natural immunity and thus need safeguarding. The treatment, which may then be limited to those requiring it, consists of passive immunization with diphtheria toxin, if protection is needed for but a short time, or, if active immunization, by injecting a mixture of toxin and anti-toxin, in which case the immunity acquired may be expected to last for one to two years. Those individuals who, without treatment, disclose by the Schick test a natural immunity are regarded as possessing it probably for life.

**REFERENCES.**—References to most of the work here detailed can be found only in the journals specially devoted to those subjects, the more important of these being:—*British Medical Journal*, *Lancet*; *Journal of Pathology and Bacteriology*; *Journal of Hygiene*; *Tropical Diseases Bulletin*; *Special Reports of the Medical Research Council*; *Journal of Experimental Medicine*; *Journal of Infectious Diseases*; *Journal of Medical Research*; *International Journal of Public Health*; *Annales de l'Institut Pasteur*; *Bulletin de l'Institut Pasteur*, *Zeitschrift für Hygiene und Infektionskrankheiten*; *Zentralblatt für Bakteriologie*, Lehmann and Neumann's *Bakteriologische Diagnostik* (1920) contains many literature references, mainly European.

(H. L. H. S.)

**BADEN, FREE STATE OF** (see 3,184).—The population of the Free State of Baden, Germany, was, according to the census of 1919, 2,208,503.

**Political and Constitutional History.**—Baden was, till the

revolution of 1918, a constitutional monarchy; the sovereign bore the title of Grand Duke. The Diet (*Landtag*), which was composed of two Chambers, had indeed the right of legislation and of voting taxation, but the ministers were appointed by the Grand Duke at his own discretion. The government had always been conducted in a liberal spirit; Baden had in Germany the reputation of being the model of a diminutive Liberal country (*ein Liberales Musterländle*), though the population was preponderantly Catholic. There was certainly a powerful Clerical minority in the second Chamber of the Diet. When at a general election there was a danger that a Clerical-Conservative majority would be elected, the two Liberal parties (the National Liberals and the Progressives) concluded an alliance for election purposes with the Social Democrats, thus constituting the so-called "grand bloc." The result was that the Social Democrats held a considerably different position in Baden from that which they occupied in the empire.<sup>1</sup> But in Baden, too, the line was drawn at allowing Socialists to become members of the Government. The Social Democratic party nevertheless endeavoured to place as few difficulties as possible in the path of the Government, and it did not, as elsewhere, vote against the budget. When the World War broke out in 1914, the leader of the Baden Social Democrats, Ludwig Frank, at once enlisted as a volunteer and fell in one of the earliest battles.

The Liberal sympathies of the Baden dynasty were maintained during the war. The heir to the throne, Prince Max of Baden, tried to exercise his influence in favour of a peace by understanding and of Liberal reforms in the internal policy of the empire. When in Oct. 1918 William II. at last decided to agree to the reform of the constitution by which the parliamentary form of government was introduced for the empire, Prince Max was appointed imperial chancellor. It was too late. He could not arrest the progress of the revolution. When the monarchy fell in the empire, it could not be maintained in Baden, although there was in this instance no reason for complaint on the score of misgovernment. On Nov. 10 the revolutionary Provisional Government was formed, containing representatives of the Social Democratic, the two Liberal parties and the Catholic Centre. On Nov. 22 the Grand Duke therefore definitely abdicated, with the assent of the heir to the throne, Prince Max.

The Provisional Government of Baden issued as early as Nov. 20 an ordinance by which elections were instituted for a National and Constituent Assembly.<sup>2</sup> This representative body met on Jan. 15 1919 and at once began to discuss the draft of the constitution which had been submitted to it by the Government. On May 21 1919 the new constitution was passed by the National Assembly. Baden was thus the first German state which put an end to the lawless revolutionary situation. The consequence, it is true, has been that the Baden constitution has in several points been nullified by the constitution of the Reich, which was enacted at a later date; for the independence of the German Territories, as the states united in the Reich are designated, was considerably curtailed by the constitution of the Reich of the year 1919. Nor is there any room in the constitutions of the Territories for provisions regarding the "Fundamental Rights of the People," since the constitution of the Reich has settled these Fundamental Rights.

Baden in 1921 was a republic with a democratic constitution. The powers of State were actually vested in the Diet (*Landtag*), which consists of a single Chamber. The Diet does not only possess the right of legislation, but it chooses the ministry and selects from among the ministers the minister-president. He has the title of "President of the State," but he is not the head of the state, but merely the person who presides over the ministry. The Diet can at any time dismiss the whole ministry or individual members

<sup>1</sup> Reich is translated "Empire" when it refers to the Hohenzollern régime; the German word Reich is retained when it refers to the German Federated Commonwealth established after the revolution.

<sup>2</sup> Each of the German states called its Constituent Assembly a "National" Assembly (*Nationalversammlung*).

of it. The franchise for the election to the Diet is possessed by all men and women who have completed their twentieth year. There must be a general election every four years. The dissolution of the Diet can be brought about before the end of the legislative period by a vote of the people. Laws can also be passed by a vote of the people, and that in two ways: a law which has been voted by the Diet can be submitted to the vote of the people by the Referendum, if the ministry so decides or if the people itself so demands; secondly, an appeal may be proposed by Popular Initiative. Laws involving an amendment of the constitution must always be submitted to a Popular Referendum. The constitution of Baden has thus a great resemblance to that of the Swiss Confederation; but there is the essential difference that in Baden the Government is dependent upon Parliament. (W. v. B.)

**BADENI, KASIMIR, COUNT** (1846-1909), Austrian statesman, was born Oct. 14 1846 at Surachovo in Galicia, his family being of Italian origin. He studied law and served some years in the Ministry of the Interior and from 1879 at Cracow as lieutenant of the governor of Galicia. He resigned the Government service in 1886, but two years later was appointed governor (*Statthalter*) of Galicia, where he ruled the Ruthenians with a strong hand. In Sept. 1895 he was appointed Austrian prime minister, and his attitude was at first satisfactory to the German-Austrians. In 1897, however, in order to gain the support of the Czechs for the new *Ausgleich* with Hungary, he made certain important concessions in respect of the official use of the Czech language in Bohemia. This was done by ordinance, without parliamentary sanction, and met with violent opposition from the German deputies, some of whom were imprisoned. The storm of indignation aroused among the German-Austrians by this policy, which led to imposing demonstrations in the streets of Vienna, led to Badeni's downfall on Nov. 28 1897. He died July 9 1909. (C. Br.)

**BADOGLIO, PIETRO** (1871- ), Italian general, was born at Grazzano (Alessandria) Sept. 28 1871. He received his commission in the artillery, and thence passed to the general staff. During the Italo-Turkish War he served in Tripoli on the staff, receiving special promotion to major after the battle of Zanzur in June 1912. In the spring of 1915 he was promoted to lieutenant-colonel and on Italy's entry into the World War he held the post of sub-chief-of-staff of the II. Army under Gen. Frugoni. In quick succession he acted as chief-of-staff of the 4th Division, and commanded the 74th Infantry Regiment on Monte Sabotino. In July 1916 he received another step, and as colonel commanded the "Sabotino Sector." He planned and carried out the successful attack on Monte Sabotino which preceded the fall of Gorizia (Aug. 1916). For this success he was once more promoted. After serving as chief-of-staff of the VI. Corps and commanding the Cuneo Brigade, he became chief-of-staff of the so-called "Gorizia Zone" under Capello, with whom he remained when the command of the "Gorizia Zone" was extended to the whole II. Army. On the eve of that army's offensive in May 1917, Capello, dissatisfied with the artillery preparation in the sector of the II. Corps, obtained the appointment of Badoglio as interim commander of the corps (May 12). After the capture of Monte Kuk and Monte Vodice this appointment was confirmed, and he received another step of promotion. He commanded the II. Corps at the beginning of the August offensive but when the XXVII. Corps on the extreme left of the attack failed to make the progress expected he was sent to take over the corps. This time, however, the endeavour to make up for lost time was unavailing. At the battle of Caporetto, Badoglio commanded the same corps, the left wing of which was broken by Otto von Below's attack from the Tolmino bridgehead. On the reorganization of the Italian Supreme Command (Nov. 1917) he was appointed as one of the two sub-chiefs-of-staff then nominated, the other being Gen. Giardino. From Feb. 1918, on Giardino's transference to Versailles, Badoglio acted as sole sub-chief-of-staff under Diaz. He conducted the Armistice preliminaries at Villa Giusti, and signed the Armistice on behalf of Italy. In Nov. 1919 he was appointed to the rank of army general and from Diaz's resignation to Feb. 1921 he was chief of the general staff in succession to Diaz.

Badoglio's rapid rise was explained by the qualities which he showed in a special degree: determination, energy, and thoroughness. These qualities, joined to a natural military instinct developed by much study and backed by a powerful ambition, marked him out early and brought him very quickly to the front. He was blamed in various quarters for his disposition of the XXVII. Corps before the Austro-German attack in Oct. 1917, but the Caporetto Commission of Inquiry rejected most of the criticisms made upon him.

**BAEYER, JOHANN FRIEDRICH WILHELM ADOLF VON** (1839-1917), German chemist (see 3,192), died at Munich Sept. 5 1917. Up to within a year of his death he continued in full active work as one of the best-known teachers in the world of organic chemistry.

**BAGWELL, RICHARD** (1840-1918), Irish historian, was born Dec. 9 1840, the eldest son of John Bagwell, M.P. for Clonmel from 1857 to 1874. Educated at Harrow and Christ Church, Oxford, he was afterwards called to the English bar, but never practised. As a large landowner in Tipperary he devoted constant and conscientious attention to local affairs, serving on all boards and committees until 1898 when, on the passing of the Local Government Act, his wide experience led to his appointment for five years as a special local government commissioner. In 1905 he became a commissioner for national education. As a historian his reputation rests mainly on his two works, *Ireland under the Tudors* (3 vols. 1885-90) and *Ireland under the Stuarts* (3 vols. 1909-16), which are monuments of careful research and wide learning. In recognition of his historical work he was given the hon. degree of Litt.D. by Dublin University in 1913 and that of D.Litt. by Oxford University in 1917. Mr. Bagwell was an uncompromising Unionist, and was well known as a speaker and writer for the cause. He died at Marlfield, Clonmel, Dec. 4 1918.

**BAIRNSFATHER, BRUCE** (1887- ), English humorist, was born at Murree, India, July 9 1887, and was educated at the United Services College, Westward Ho. He became a civil engineer, and also had some military experience in a militia battalion of the Royal Warwickshire Regt. In 1914 he rejoined this regiment and went to France, serving there until 1916, when he obtained a War Office appointment. Bairnsfather's reputation as an artist was made by his black-and-white sketches of life in the trenches, which first appeared in *The Bytander*. His soldier characters became popular favourites, and a play, *The Better 'Ole* (1917), founded on the adventures of "Old Bill" and his friends, enjoyed a great success. Many of Bairnsfather's drawings were published in volumes entitled *Fragments from France*. He also produced *Bullets and Billets* (1916) and *From Mud to Muffin* (1919). In 1919 he started *Fragments*, a weekly comic paper.

**BAKER, GEORGE PIERCE** (1866- ), American educationist, was born at Providence, R.I., April 4 1866. He graduated from Harvard in 1887 and taught English there as instructor, assistant professor and, from 1905, as professor. His courses dealing with the theory of the drama were highly successful, and his famous laboratory, known as the "47 Workshop," afforded practical training for his students, many of whom became well-known playwrights. In 1919 he was entrusted with the preparation of a pageant to commemorate the tercentenary of the landing of the Pilgrims at Plymouth in the State of Massachusetts. This pageant, "The Pilgrim Spirit," was presented accordingly at Plymouth in Aug. 1921.

His works include *Specimens of Argumentation* (1893); *Principles of Argumentation* (1895); *The Forms of Public Address* (1904); *The Development of Shakespeare as a Dramatist* (1907); *Some Unpublished Correspondence of David Garrick* (1907); *The Correspondence of Charles Dickens and Maria Beadnell and Dramatic Technique* (1919) and *Modern American Plays* (collected and edited with introduction, 1920).

**BAKER, HERBERT** (1862- ), English architect, was born in 1862, and educated at Tonbridge school. He was articled to Arthur Baker, and later entered the office of Sir Ernest George, where he remained as assistant for some years. He studied at the R.A. schools, and in 1889 was awarded the



Ashpital prize of the R.I.B.A. In 1892 he left England for South Africa, and there, with Cecil Rhodes as his friend and patron, began the work of reviving the old traditions of the architecture and craftsmanship of the colony. For Rhodes he built Groote Schuur, afterwards the permanent home of the prime ministers of South Africa, and also a house which the same patron built on Table Mountain for his friend Rudyard Kipling. Cecil Rhodes sent him on a tour of travel and study in Egypt and southern Europe, and, as a recognition of this generosity and the value of such an opportunity to a young architect, Baker founded the South African Scholarship at the British School in Rome. After the death of Rhodes he carried out the great Memorial on the slopes of Table Mountain, important features of which were the sculpture work of J. M. Swan, R.A.—the bronze lions and a head of Rhodes himself—and the mounted equestrian figure—"Physical Energy"—by G. F. Watts, R.A.

The end of the South African War saw Baker in full practice in the Transvaal and South Africa. In addition to the Government buildings at Pretoria—the administrative capital of South Africa—he carried out the cathedrals at Cape Town, Pretoria, and Salisbury, and many colleges and schools. Amongst the houses he built in South Africa are the Government House in Pretoria, and that for Sir Lionel Phillips, afterwards the governor-general's Johannesburg home. He also designed the buildings for the S. A. Institute of Medical Research at Johannesburg, and laid out many model mining villages on the Rand. His works in England include Sir Philip Sassoon's house at Lympne and the restoration of Chilham Castle, Kent. He was appointed one of the three principal architects for the war cemeteries in England and Flanders, and carried out many war memorials in England, amongst them those at Canterbury, Winchester and at Harrow school. Baker was appointed in 1913 joint architect for the new Imperial City of Delhi, in collaboration with Sir Edwin Lutyens. For this great scheme he designed the buildings for the secretariats, the Legislative Assembly, the Councils of State and of Princes, and the Viceroy's Dome for General Assembly.

**BAKER, NEWTON DIEHL** (1871– ), American politician, was born at Martinsburg, W. Va., Dec. 3 1871. He was educated at Johns Hopkins (A.B. 1892) and Washington and Lee (LL.B. 1894). In 1896 he became private secretary to Postmaster-General Wilson, but the following year opened a law office in his native town. Later he moved to Cleveland, O., where in 1902 he was made city solicitor and in 1912 mayor. The latter office he had held for two terms when in 1916 he was appointed U.S. Secretary of War by President Wilson. He had declined the Secretaryship of the Interior in 1912. After the outbreak of the World War he endorsed the Administration's peace policy, supported the League to Enforce Peace, and urged that the national guard be tried fully before compulsory service be decided upon. After America entered the war he recommended moderation towards conscientious objectors and forbade men in uniform to interfere with anti-conscription meetings. The charge of pacifism was often brought against him, and his career generally as Secretary was widely condemned throughout the United States as lacking in energy, foresight and ability, and especially for his failure to prepare adequately in the months immediately preceding the American declaration of war.

**BAKST, LEON NICOLAIEVICH** (1866– ), Russian painter and theatrical designer, was born at St. Petersburg May 10 (April 27 O.S.) 1866. He was educated at St. Petersburg, where he afterwards studied art, and later went to Paris, subsequently returning and working in Moscow. In 1906 he settled in Paris, and soon became popular as a designer. In 1909 the Imperial Russian Ballet first visited Paris, and Bakst at once leapt into fame through his designs for the setting of the ballets *Schéherazade* and *Cleopâtre*, followed in 1912 by *L'Après-Midi d'un Faune*, *Hélène de Sparte*, and *St. Sébastien*, and in 1913 by *La Pisonella*. He published in 1913 an article in *La Nouvelle Revue*, entitled "Les Problèmes de l'Art Nouveau."

See *L'Art décoratif de Léon Bakst*, with appreciation by Arsène Alexandre, translated by H. Melvill (1913).

**BALAKIREV, MILI ALEXEIVICH** (1836–1910), Russian musical composer (see 3.234), died at St. Petersburg in May 1910.

**BALDISSERA, ANTONIO** (1838–1917), Italian general, was born at Padua 1838, and died at Florence, on Jan. 9 1917. His birthplace in 1858 being still under Austrian rule, young Baldissera entered the Austrian army, in which he served with distinction in an infantry regiment; he was captain in the 7th Jägers at Custozza (1866). But when Venetia became Italian, he opted for Italian nationality, retaining his rank in the Italian army. In 1879 he was promoted colonel of the 7th Bersaglieri and major-general in 1887, when he went to Eritrea under Gen. Asinari di San Marzano, remaining in the colony as governor after the latter's return. Both as a soldier and an administrator he showed high qualities. He occupied Asmara, Keren and other territories, defeated the armies of Ras Alula, and had planned still further extensions of Italian dominion, profiting by the anarchy of Abyssinia. He organized the admirable native troops (Ascar), developed agriculture and built roads. But owing to a disagreement with the home Government over his Abyssinian policy he asked for and obtained his recall after two years of successful activity. In 1892 he was promoted lieutenant-general. When war with Abyssinia broke out in 1895 the then governor of the colony, Gen. Baratieri, did not enjoy the confidence of the Government, which decided to send out Baldissera once more. Although the appointment was kept secret, Baratieri got wind of it, and this probably decided him to attack the enemy with an inferior force and insufficient supplies, hoping to win glory for himself before his successor's arrival. The result was the disaster of Adowa (March 1 1896); when Baldissera arrived he found a defeated and demoralized army, and the victorious enemy advancing in force. With lightning speed he reorganized the remains of Baratieri's army and the reinforcements just landed, freed the beleaguered garrisons of Cassale and Adigrat, drove back King Menelek's army and reoccupied a large part of the lost territory. But peace was concluded before he had completely retrieved the defeat of Adowa, and he was forced to limit his activities to the internal reorganization of Eritrea. But even this task he could not carry out as thoroughly as he wished owing to the opposition of the home Government, which was tired of African affairs. In 1897 Baldissera returned to Italy and resumed his duties in the home army, successively commanding the VII. and VIII. Army Corps. In 1906 he was made a senator. In 1908 he had to retire from the army under the age limit.

**BALFOUR, ARTHUR JAMES** (1848– ), British statesman (see 3.250), was confronted, as Conservative leader, after the general election of Jan. 1910, with a situation of some embarrassment. He had to endeavour to save the effective authority of a second Chamber and to avert Irish Home Rule, with his supporters not yet completely united on the issue of Tariff Reform, and in face of a Liberal Ministry dominated once more by a body of 80 Irish Nationalists, who held the balance of power in the House of Commons, and who notified their intention not to vote for Mr. Lloyd George's disputed budget unless their forward policy was adopted. He advocated House of Lords reform as an alternative to the Ministerial Veto Resolutions, which he denounced as irrational; and when Mr. Asquith announced that, if he could not secure statutory effect for his policy in that Parliament, he would not dissolve except under conditions which would ensure that the will of the people should be carried into law in the next Parliament, he exclaimed that the Prime Minister had "bought the Irish vote for his Budget, but the price paid is the dignity of his office." In the lull in the party fight which followed the death of King Edward, Mr. Balfour welcomed the suggestion of a conference between the parties to endeavour to arrange a compromise, and was one of the eight leaders who met on 21 occasions between June and Nov. without coming to an agreement. When the

conference failed and ministers announced another dissolution. Mr. Balfour did his best to rouse the country to the dangers which, in his opinion, threatened it. In a speech at the Albert Hall he expressed his readiness to submit *Taxif Reform* to a referendum, and maintained that the Government for their part should be ready to submit *Home Rule* also to a referendum. The offer was not accepted. When the second general election of 1910 confirmed the verdict of the first, the dissatisfaction with Mr. Balfour's leadership, which had been long entertained by a considerable section of the Unionists, began to spread. It was pointed out that he had now led the party to three electoral defeats in succession; and this record was contrasted with Lord Salisbury's victories in 1886, 1895 and 1900. The course of the session of 1911 intensified this dissatisfaction. Mr. Balfour did indeed fight the Parliament bill, in its passage through the House of Commons, with courage, persistency, acuteness and passion. While he admitted the need for some change in the Constitution, and promoted Lord Lansdowne's measure for reconstructing the House of Lords and making it a Chamber partly hereditary, partly nominated, and partly elective, he denounced the Ministerial bill as practically constituting single-chamber government. Ministers, he said, were forcing constitutional changes on the country by coercion as they had imposed them on the country by fraud. In committee he strove hard, but in vain, to get fundamental laws exempted from the operation of the bill. But he shrank, as in 1832 the Duke of Wellington had shrank, from encouraging the House of Lords to persist in opposition, when ministers announced that they had obtained the King's consent to the creation of sufficient peers to make its passage certain. He did indeed move a vote of censure imputing to ministers a gross abuse of the Constitution in the advice they had given to the Crown; but he declared that he would stand or fall with Lord Lansdowne in the recommendation which the latter made to the Unionist peers to abstain from further resistance as being no longer free agents. This attitude was passionately resented by a large number of "Diehards," who organized themselves under the leadership of Lord Halsbury, and with the approval of Mr. Joseph Chamberlain, then in retirement owing to illness. Mr. Balfour's counsel prevailed, and the bill was allowed to pass; but his position and authority as leader had been seriously shaken. Though both he and leading "Diehards," in speeches in the autumn, treated the dispute as ancient history, he decided that the time had come for him, after 20 years of leadership, to resign; and he announced his decision to a meeting of the Conservative Association in the City of London on Nov. 8. He said that he desired to abandon his heavy responsibility before he could be suspected of suffering from a sort of petrification in old courses and inability to deal with new problems; and that he felt he had not the vigour, at his time of life, again to conduct a ministry. He treated the unrest in the party as nothing exceptional, and spoke of Unionism as on the upward grade. The announcement, in spite of the signs of discontent, came as a great shock to the party and the country; and the Prime Minister, Mr. Asquith, himself expressed the general feeling when he said at the Guildhall banquet next day that the resignation involved an irreparable loss to the daily life of Parliament.

Mr. Balfour was then only 63, and his powers as a parliamentarian were really at their height. Although after his resignation of the Unionist leadership he devoted more time to his manifold other interests in life—philosophy, science, literature, music—he still took at intervals a prominent part in debate, and made occasional speeches in the country, giving throughout a loyal support to his successor in the House of Commons, Mr. Bonar Law. The renewed controversy on *Home Rule* afforded him a great opportunity, and the powerful series of speeches which he delivered, at Westminster and elsewhere, in the course of the next three years, did much to awaken Great Britain to the imminent danger of civil war in Ireland, and to force ministers into the policy of excluding Ulster, in some form or other, from the operation of their bill.

When the World War broke out he cordially accepted the policy of the Unionist leaders in sinking all political differences in support of the national Government. Speaking at the Guildhall on Lord Mayor's Day 1914, he said that the Allies were fighting for civilization and the cause of small states, and, whether the war was short or long, they would triumph. In this spirit he joined the first Coalition Government in May 1915, accepting the first lordship of the Admiralty under Mr. Asquith; and from this time onward he took a statesman's share in the conduct of the war, and in the making of peace. The Admiralty had been distracted by a quarrel between Mr. Churchill, the First Lord, and Lord Fisher, the distinguished admiral, who was First Sea Lord. Both had now resigned, and Mr. Balfour appointed an eminent scientific sailor, Adml. Sir Henry Jackson, as First Sea Lord, and speedily restored the harmony of the Board. He also reversed Mr. Churchill's policy of differentiating against prisoners from submarines as compared with other German prisoners, though he insisted that there was no change of opinion as to the unlawful, mean, cowardly, and brutal character of their acts. In introducing the Navy Estimates in 1916 he said that, except in armoured cruisers, the fleet was far stronger than when war broke out; that ships, guns and ammunition had increased and would increase; and that the *personnel* had more than doubled. His principal critic was Mr. Churchill, who averred that the existing Board had not so much energy, speed, push and drive as his own, and who, to the astonishment of the House, recommended the recall of Lord Fisher—a suggestion upon which Mr. Balfour commented severely. Perhaps the best work which he did at the Admiralty was the issue, at intervals, of some cogent papers, mainly for the benefit of the Americans, vindicating the great work of the British navy in the war, and exposing the fallacies involved in the captivating phrase, "the freedom of the seas." The chief naval battle of the conflict, the battle of Jutland, was fought during his term of office; and he incurred widespread criticism by the manner in which the news was officially communicated to the public, the great losses in men and ships being dwelt on to such an extent as to suggest that, instead of being a victory, the action was a defeat. In a speech a few days later he claimed that, as a result of the fight, the Germans were relatively far inferior to what they had been. In late Oct. there was a daring German raid by 10 destroyers into the English Channel; an empty British transport and one British destroyer were sunk and another destroyer seriously damaged. Mr. Balfour confidently predicted at the Guildhall on Lord Mayor's Day that any further Channel raiders would suffer disaster. His confidence was probably based in part on a new arrangement of the high naval appointments, which he announced before the end of November. Sir John Jellicoe was brought into the Admiralty as First Sea Lord, and Sir David Beatty was appointed to succeed him as commander-in-chief. These changes were promptly followed by a change of First Lords when Mr. Lloyd George formed his Ministry in Dec. 1916. Lord Grey of Fallodon declined to continue at the Foreign Office under the new Prime Minister; and as it was essential to have a man of experience and weight there, the post was pressed upon Mr. Balfour, who had in times past occasionally acted as Foreign Secretary in Lord Salisbury's absence, and had been intimately associated, during his Premiership, with Lord Lansdowne's work in the department.

Mr. Balfour took up his new duties as Foreign Secretary only a few weeks before Germany instituted the unrestricted submarine warfare which brought the United States into the war; and in April 1917 he headed a British mission which visited America in order to arrange for regular cooperation between the two countries. His attractive personality greatly impressed his hosts, and he received the compliment of being invited to address the House of Representatives on May 5; his speech showed a complete sympathy, that was highly appreciated, with the spirit in which the United States had entered the war. He subsequently proceeded to Canada, and there addressed the two Houses of Parliament. The concentration of power in the

hands of the War Cabinet, and the great personal ascendancy which Mr. Lloyd George, as Prime Minister, rapidly acquired, both tended rather to reduce the importance of the Foreign Secretary during Mr. Balfour's tenure of the post. It should be noted, however, that it was Mr. Balfour, as Foreign Secretary, who in Nov. 1917 gave a promise on behalf of his Government to provide a "national home" for the Jews in Palestine after the war. The exceptional amount of work to be dealt with at this period impelled him to ask for extra help in the office; and Lord Robert Cecil was taken from the Ministry of Blockade in the summer of 1918 and made an assistant Secretary of State. Mr. Balfour went to the Paris Conference in 1919 as the second British plenipotentiary; but as eventually the terms of peace were settled by a council of three, Mr. Wilson, M. Clemenceau, and Mr. Lloyd George (or of four, when the Italian prime minister attended), his share in the work was somewhat subordinate, though he appended his signature to the Treaty of Versailles, and to the treaty of guarantee to France against German aggression. When the Conference was over, he was glad to be relieved of the burden of a laborious office, and therefore relinquished the Secretary of State's seals to Lord Curzon, but remained himself in Mr. Lloyd George's Cabinet in the honourable but comparatively sinecure office of Lord President of the Council. He was appointed chief representative of the British Government at the first Assembly of the League of Nations in 1920; and also at the Disarmament Conference at Washington, D.C., in Nov. 1921.

Mr. Balfour's eminence, and his patriotic readiness to resume in war-time, in spite of advancing years, official labours in a secondary position, were suitably recognized on the King's birthday in 1916 by the grant of the Order of Merit. In 1919 he received a distinction which he must have peculiarly valued, when he was elected chancellor of his old university, Cambridge, in succession to his brother-in-law, Lord Rayleigh.

(G. E. B.)

**BALFOUR OF BURLEIGH, ALEXANDER HUGH BRUCE,** 10TH (OR 6TH) BARON (1849-1921), British politician, was born at Kennet, Alloa, Jan. 13 1849, the son of Robert Bruce of Kennet. He was educated at Loretto, Eton and Oriel College, Oxford, and in 1869 was restored by Act of Parliament to the barony of Balfour of Burleigh, to which he was entitled by his descent from the 5th baron, who was attainted after the Jacobite rebellion of 1715. He first came into public notice as a member of the factory commission of 1874, and afterwards acted as chairman of many other commissions, including that on educational endowments (1882-9). From 1889 to 1892 he was parliamentary secretary to the Board of Trade in the Conservative Government, and from 1895 to 1903 (when he resigned as a Free Trader opposed to tariff reform) Secretary for Scotland. In 1903 he became chairman of the commission on food supply in time of war, and in 1909 of that on trade relations with Canada and the West Indies, receiving in 1911 the G.C.M.G. as a reward for his services. From 1916 to 1917 he was chairman of the committee on commercial and industrial policy after the war. Lord Balfour, who received hon. degrees from all the Scottish universities, was from 1896 to 1899 lord rector of Edinburgh University and from 1900 chancellor of St. Andrews University. In 1904 he was appointed Lord Warden of the Stannaries. He published in 1911 *The Rise and Development of Presbyterianism in Scotland*. He died in London July 6 1921.

**BALKAN CAMPAIGNS** (1914-8): see SALONIKA CAMPAIGN and SERBIAN CAMPAIGNS.

**BALKAN PENINSULA** (see 3.258).—Geographically speaking, the Balkan Peninsula is a meeting-point of European and Asiatic relief (see fig. 1): the Dinaric ranges belong to the Alps, the Carpathians and the Balkans seem to be connected in an arc, and the main tectonic systems of the peninsula have a geological structure similar to the ranges of Asia Minor from which they have been separated since the Pliocene or diluvial period. In the same way, areas of strongly contrasted climate are to be found in close proximity, e.g. Mediterranean on the Adriatic and Aegean coast; Steppe, like that in Asia, on the

extensive plain formed by the Danube and the Maritsa; Central European in most of the peninsula; Alpine on the higher summits (see figs. 1 and 2). They are sometimes intermingled: valleys which reach far into the mountain masses enjoy a Mediterranean climate as, e.g. the lower Drin valley in Albania.

The distribution of soil affects the character of the vegetation as much as climate: north of the Balkans and of the Kopaonik plateaus extensive tracts are covered by lake or marine deposits, loess and humus, where steppe meadows, forests and general cultivation prevail. On the central highlands are coniferous forests and Alpine pastures, while the isolated basins show the characteristics of northern soils and vegetation. The slopes facing the Aegean Sea, like those facing the Adriatic, give rise to deciduous bush and *pseudo-magnus*. The extreme limit of Mediterranean vegetation sometimes reaches as far as the upper Morava and the depressions S. of the Balkans in the eastern part of the peninsula, but does not extend farther than a few miles from the Adriatic or a few hundred metres above sea-level in the western part. To N. and E. of this limit, large areas, especially in Bosnia and Serbia, are still covered with forests of oak and birch trees, remnants of extensive primitive forest growth in the valleys as well as on the hills; while to S. and W. low scrub prevails on the bare rocks. Tobacco, rice and cereals are grown in the fertile plains of Thrace and Macedonia, olive and orange trees flourish in the most sheltered places along the coast.

The extension of mountain barriers, climatic influences and zones of vegetation do not alone make the Balkan Peninsula a world by itself. Peripheral influences travel from Italy over the Adriatic, by the straits and the island-dotted Aegean to the indented Hellenic coast, then through the great longitudinal depressions which traverse the peninsula from N.W. to S.E. The morphological features combine to constitute the basis of natural regions—the Aegean, the Balkans, the Morava-Vardar and the Pindo-Dinaric regions—whose main characteristics depend more on morphology than on ethnography or history.

**Natural Regions.**—The Aegean region is remarkable for the indentation of its coast. On the Hellenic part (Peloponnesus and Euboea) each morphological feature—*islands, gulfs and headlands*—points S.E. towards Asia Minor and turns its back to Europe. Karstic characteristics are well developed in the limestone areas of the Ionian coast. The climate is typically Mediterranean: summers are rainless, the atmosphere is clear and temperature is high. The rivers are not perennial. Among the *magnus* growth, cultivation is restricted to small fields like oases. On the slopes and in the bottoms of the sheltered depressions, oranges, grapes, lemons and pomegranates survive the dry summer: the olive is prominent in the landscape. Animal as well as vegetable life is very restricted. The isolation of the units and the poorness of the soil would have almost prevented development if the population had not turned seaward, attracted by extraordinary opportunities for fishing, navigation and trade. The Aegean is the only region in the peninsula inhabited almost exclusively by Greeks, mostly seamen or traders, living in towns of the Mediterranean type, with high stone houses and narrow streets, or in large villages on terraces.

The Thraeo-Macedonian region combines the characteristics of the Hellenic and continental regions. The coast is also indented, but the large valleys of perennial streams (Vardar, Struma) give access to the gulfs. The land surface, chiefly consisting of crystalline, metamorphic rocks, denuded, displaced and dislocated, shows sharp contrasts of plateaus and basins, and here and there residual ridges. The tectonic basins, when not filled by the sea, as at Salonika and Orfano, are occupied by alluvial and tertiary lake deposits as in Thessaly and Thrace, or by lakes (Doiran, Langadha, Beshik) or in the valleys, by marshes. The climate is half continental and half Mediterranean with rainy summers and cold winters. The *Vardaras* blowing in the rear of the deep winter cyclones brings snow to the hills and freezes the coast, while violent south-west winds bring excessive heat in summer. The proximity to the coast of high hill masses has a great influence on the vegetation: the true *magnus* growth extends to an altitude of 200 metres on the coastal slopes, but olive and vine cultivation reaches as high as 400 metres. Oaks and chestnuts, at first scattered, increase with the elevation until they form forests, then coniferous trees appear and finally the cloud-wrapt Alpine summer pastures provide an area of "transhumance" to Kutzo-Vlakh and Slav shepherds, who spend the winters on the coastal plains. The area available for agriculture lies in the basins—Thessaly for wheat, Seres for cotton, the plain of Salonika for rice, Kavalla for tobacco. The towns (Salonika, Kavalla), inhabited by Spanish Jews, Turks and Greeks, are built like amphitheatres on the slopes and the villages are inhabited by Slavs and Arumans. The latter are often of the Turkish *Chifuk* type with square rooms grouped around the landowner's house, or are composed of houses made of sun-dried bricks.

Strongly contrasting with the Aegean, the Balkan region is a continental mass. The straight Black Sea coast does not favour peripheral influences travelling inward, and the high Rila and Rhodope systems form a barrier against western penetration. The west-east folded Balkans divide the region into two parts, the lower Danubian plateau on the N., and the Maritsa basin on the S., but



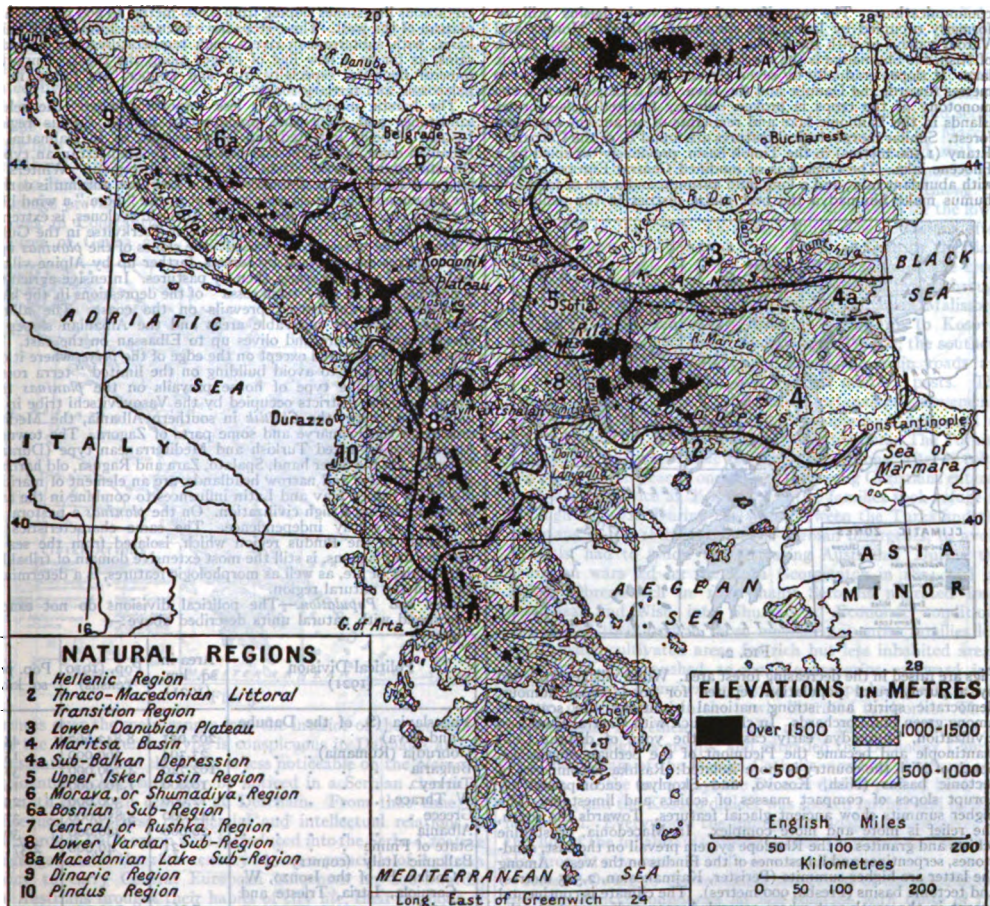

FIG. 1.

low passes render communication easier. The lower Danubian plateau is the only part of this region in which relief, climate and production are almost uniform; the unbroken monotonous surface is dissected regularly by deep-cut asymmetric valleys facing fault scarps, running from S. by W. to N. by E. Like southern Russia and Rumania, it is covered with neogene sediments and loess of wonderful fertility, but trees and grass are very scarce out of the valleys, the water table being too deep down. During excessively dry summers the small streams cease to flow, and in cold winters even the Danube is frozen. Summer droughts make the crops of wheat uncertain. The characteristics of extreme continental climate and vegetation increase eastward in Dobrujda and favoured the settlement of the steppe Slavs and Ugro-Finnish Bulgars, while the uniformity of relief and the proximity of Constantinople made control of the country by the Turks easy.

The central and western Balkans stand out in contrast: high hill masses of palaeozoic schists, granite and mesozoic rocks, often chalk, are bounded on the south by abrupt fault scarps of a few hundred metres overlooking the plains, and, on the north, gradually fall in folded ranges. The eastern Balkans, consisting of sandstone, schists, flysch, are lower. Unlike the mountains of the central parts of the peninsula, the folded Balkans contain few faulted basins (Orhaniye). Except for the Yantra and Isker running south-north through the massifs and the Kamtshiya and Provadiya running west-east through epigenetic ravines, they have an undiversified drainage and are like the basins cultivated with oats, barley and potatoes, while cattle are raised on the grassy and forested hills. Between the schists and granites of the Rhodopes and the mesozoic rocks of the Balkans lies the tectonic basin of the Maritsa, showing strata of sandstone and paleocene limestone below alluvial deposits. The climate varies:

it is Mediterranean as far north as Philippopolis, favouring the cultivation of maize, tobacco, the pepper plant, the vine and mulberry trees along the Maritsa; in the east around Jamboli and Stana Zagora a steppe climate prevails, favouring wheat. The small tectonic basins of the sub-Balkan depression are liable to lesser extremes of climate and are well known for their rose gardens as at Kazanlik and fruit orchards as at Zlatitsa. The whole region facing Constantinople felt Byzantine or Asiatic influences strongly and was the first domain of the Bogomile during the Middle Ages.

West of Sofia, the upper Isker basin is a natural Viskar unit. In the centre, the Viskar and Lulyin mountains are an area of eruptive rocks and mesozoic strata folded east-west and surrounded by low limestone ridges, gentle on the north (Srbnitsa) and ragged on the south (Vlaskha). Isolated tectonic basins and karstic depressions, such as Kyustendil and Grahovo, are the only cultivable areas. The country, poor and deforested, is a barrier to communication—the Shóp tribe lives there under primitive conditions with Bulgars settled at the approaches. Sofia overlooks the Isker, Struma and Nishava, leading respectively to the Danube, to the Aegean and to the Morava-Vardar. To the south, the Rhodope system, a high mass showing glacial valleys and cirques, and almost perennial snows, is covered with forests or meadows partly inhabited by Pomaks, Yuruks and by transhumant Kutzo-Vlachs (see fig. 3).

Unlike the Balkan the Morava-Vardar region is not open to eastern influences. Its main communications are longitudinal, along a depression leading from Central Europe to the Aegean Sea. Various formations are displayed in the relief—the pretertiary Rhodope mass, the tertiary Dinaric and Carpathic ranges, the eruptive rocks of the Ibar and Bregalnitsa with their rich iron and copper fields, most of them by their great height impeding the west-east

communications. The *massifs* enclose tectonic basins still or formerly occupied by lakes, and connected with the Morava and Vardar valleys or with the Ovtshé Polyé and the Strumitsa. North of Nish, the Shumadya is the southern part of the neogene Pannonic lake. It slopes gradually by seven terraces from 960 metres to 120 metres towards the Danube and the Sava. On a lacustrine soil, the rotation of the crops is broken only by forested hills—former islands in the Pannonic lake and remnants of an ancient extensive forest. Similar morphological features are found E. of the Carpathic Rityny (1,566 metres) in the Timok basin, previously occupied by a Pliocene lake. The climate is of modified Central European type, with abundant rain; and a long mild autumn, and a soil of loess and humus make Shumadya the best maize district in the peninsula.

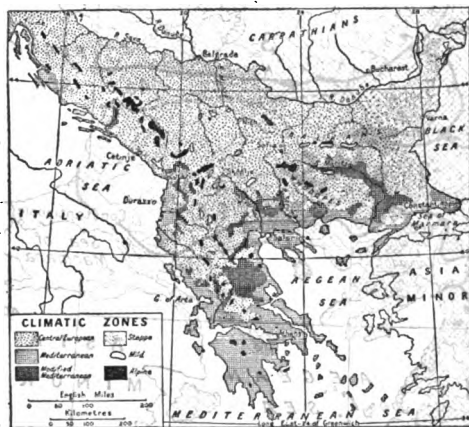

FIG. 2.

Figs are raised in the decreasing forest area. White villages, crowded by a purely rural population, reputed for good sense, humour, democratic spirit and strong national traditions, are scattered among green plum orchards. In close touch with Central European civilization, Shumadya early cast off the yoke of distant Constantinople and became the Piedmont of the Serbian renaissance. South of Nish the country is more isolated: Rashka is composed of tectonic basins (Nish, Kosovo, and Skoplye) encompassed by abrupt slopes of compact masses of schists and limestone. The higher summits show ancient glacial features. Towards the south, the relief is more and more complex. In Macedonia, crystalline schists and granites of the Rhodope system prevail on the east, sandstones, serpentines and limestones of the Pindus on the west. Among the latter are higher summits (Perister, Kajmakalan, 2,525 metres) and tectonic basins (Presba, 900 metres). The climate is continental except in the south-east where several Aegean gulf winds penetrate the interior along the Struma and Vardar, but winters last longer and are colder than in Shumadya. The lake-floored basins are occupied by orchards or wheat and flax, but forests and summer pastures of the hills are a region of "transhumance," especially in the west, equidistant from the Adriatic and the Aegean. Fields of poppies and rice and vineyards occupy large spaces in south-eastern Macedonia. The inhabitants live mostly in the basins but also on the terraces. In Rashka and Macedonia towns are more of the Turkish type—with their aggregations of wooden shops on narrow, dirty streets grouped round a central covered bazaar. In Shumadya, more open to European influence, the town streets converge towards a central *piassa* or market, and the villages extend along valleys and roads, contrasting with those of the *Chiflik* type of the Vardar country. There isolation of small natural units helped the particularism and submission to Turks which are still noticeable amongst the people, though disappearing through the influence of returned emigrants.

The Pindo-Dinaric region differs from that of the Morava-Vardar in its lack of penetration and union and by a well-defined morphology. From the Lyublyana basin to the Gulf of Arta, it is delimited on the E. by depressions, among which are the upper valleys of the Vrbas, Neretva and Drin. The beds are folded and dislocated N.W.-S.E., so that from W. to E. the littoral area (*primorje*) is succeeded by a barren karstic plateau (*zagora*) and then by high mountain ranges (*planina*) parallel to the coast, which is a coast of submergence of which the higher parts form islands. The strike of the folds restricts transverse relations, except S. of Scutari where, in the Pindus ranges, it becomes west-east. Crests of the underlying carboniferous rocks often appear through the folded and dislocated surface, but the ragged dolomitic peaks are higher. Depressions and gentle slopes prevail in the Bosnian schists of the east, steps of

cretaceous limestones sloping from 2,000 metres to 800 metres to the plateau of the west. These steps have been transformed into barren karst, with subterranean rivers, high temperatures and abundant rains, as far as a new line of ranges along the coast. Important mineral deposits, especially iron and copper, are found in the palaeozoic and tertiary rocks.

The karstic morphology is less important where the schists, sandstones and serpentine predominate in the Pindus regions. Instead of being indented and island-dotted, as in Dalmatia, the Albanian coast is straight and detac. The Mediterranean type of climate extends farther than in the Dinaric regions. Winters last long and snowfalls are abundant on the *planinas*, autumn is early in the *zagora*, and the barometric gradient in the "bora," a wind blowing from the mountains towards the Adriatic cyclones, is extremely steep. The rainfall reaches 4,640 mm. at Tsakirjeh in the Gulf of Cattaro. The vegetation is varied: the slopes of the *planinas* up to 1,700 metres are occupied by forests, farther up by Alpine villages and fields of summer crops, then by pastures. Intensive agriculture is possible only on the "terra rossa," of the depressions in the karst. Mediterranean cultivation prevails on the coast. The alluvial Pindus valleys are cultivable areas and the Albanian slopes are covered with pasture and olives up to Elbassan on the east. The population is scattered except on the edge of the *polye*, where it concentrates in order to avoid building on the limited "terra rossa" area. The Alpine type of house prevails on the *planinas* from Carniola to the districts occupied by the Vasoyevitschi tribe in the upper Lim valley, the *Chiflik* in southern Albania, the Mediterranean on the Primorje and some parts of Zagora. The towns in Albania are of mixed Turkish and Mediterranean type (Durazzo, Valona). On the other hand, Spalato, Zara and Ragusa, old harbours along small bays and narrow headlands, are an element of maritime life which helped Slav and Latin influences to combine in the early cities, producing a high civilization. On the *planinas* a pastoral life favoured a sturdy independence. The same characteristics are noticeable in the Pindus region which, isolated from the sea by marshes and lagoons, is still the most extensive domain of tribal life. Thus, unity of life, as well as morphologic features, is a determinant factor of the natural region.

**Area and Population.**—The political divisions do not exactly correspond with natural units described above:—

Political Division (1921)	Area in sq. km. (1921)	Pop. (1910 census)	Pop. per sq. km.
Yugoslavia (S. of the Danube and Sava)	202,051	8,842,667	43
Dobruđa (Rumania)	23,304	360,000	15
Bulgaria	102,740	4,700,000	38
Turkey	10,000	1,400,000	14
W. Thrace	12,000	300,000	25
Greece	142,000	5,850,000	37
Albania	26,000	780,000	30
State of Fiume	21	49,806	2,371
Balkan Italy (country of Gorizia E. of the Isonzo, W. Carniola, Istria, Trieste and Zara)	7,969	739,952	92
Totals	526,085	23,022,425	42

**Civilizations and Metanastatic Movements** (see fig. 3).—Various civilizations—Byzantine, Turkish, Occidental and Patriarchal—were adapted in their distributions to geographical conditions, each of them leaving a deeper impress in a definite area. Byzantine influence impressed material life and moral ideals throughout the Middle Ages, and it was carried by the Greeks and Aramunni along the longitudinal depressions under Turkish rule up to the Danube and the Sava, but could not be maintained in the areas successively cleared by the Turks. It does not now appear farther north than the Balkans and the Shar Planina. It is still noticeable in the city life, relying on strict trade unions, in dogmatic quarrels, and in the struggle to make money at all costs. Turkish and Oriental influences first came across the straits and the island-dotted Aegean. The Greeks and Turks brought wheat, fruit trees, flowers, and methods of irrigation from Asia Minor, the last of these especially into Bulgaria. The Islamized Serbs extended the area of Turkish habits and mentality far north and west into Bosnia. Turkish and Oriental influences are still manifested in special care for weapons and harness, in lazy habits, and in a strange mixture of goodness with brutal passions. Under submission for so long, the Christians still maintain the *raya* mind and conceal their feelings. In Turkish territory and Thessaly the economic system of tenure called

*Chifli* persists. The *begs* and *agas*, and Greek landowners of Thessaly, the former being descendants of the landowners who adopted the creed of the conquering race, own the ground cultivated by the *kmets* or *chiflihiys* and impose heavy taxes upon them.

The western European countries and the Balkan world came early into contact. The Romans crossed the Adriatic and Latinized the old Illyrian tribes up to a line from Alessio on the Adriatic to Ratiaria on the Danube, south-east of which the Greek language prevailed. Later, the House of Anjou in Albania, the Franks in Constantinople, and the maritime and commercial empires of Genoa and Venice hardly carried Occidental in-

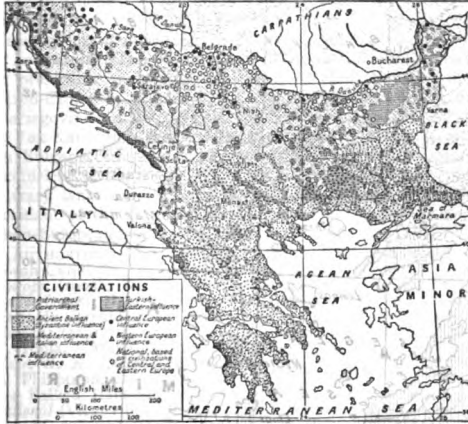

FIG. 3.

fluences over the main ranges into the interior of the peninsula. But the Mediterranean type is conspicuous in Dalmatia and in Constantinople, and the Latin is less noticeable on the *planinas*. Occidental architecture may be noticed in a Serbian church of the 13th and 15th century at Detchain. From that time, in consequence of these commercial and intellectual relations, a few words of Latin origin were introduced into the Serbo-Croatian language. After the 18th century it was a principle of Austrian policy to carry Central European influences far southwards; the Austrians brought their habits of city life, their methods of trade, their engineering, and their house furniture, but did not make their mark on intellectual development. North of the Shar Planina and of the Balkans, except on the coast and in the Serbian plains, the patriarchal type of civilization prevails. It is also noticeable in Albania. Its main characteristics are the organization of the tribes in Montenegro, northern Albania and Raskha, and that of the *Zadruga* from the Adriatic to the river Iskar. In the latter three or four families live together, obeying the oldest member of the group, and cultivating ground which is owned in common. The *Zadruga* is chargeable for the taxes, controls the expenditure, is responsible by law for, and makes profit on the work of, each member. Some groups consist of as many as 70 members. The ground, except forests or pastures (*stojer*), becomes more and more divided up. The nucleus of the tribes is made up of old families related together and enlarged by the admission of foreign groups, or by conquest of new territories. The Montenegrin tribes hardly made a livelihood on the barren karst and had to keep small in number; while the Rascian tribes, in an area full of resources, became more and more important. On account of geographical isolation and the prevention of exogamy amongst the old tribes, tribal life developed into particularism, but the wars against the Turks united those tribes which, when not fighting, were occupied only in pastoral pursuits or the leading of convoys.

The distribution of civilization has been greatly influenced by metanastasic movements. The invasion of the Turks in the 14th

century determined local migrations, especially among the Serbs. The Dinaric Serbs from Montenegro and Herzegovina moved eastward and settled in the forest glades of Shumadya, or northwards along the Dinaric ranges as far as Istria and Carniola. People from Kosovo and Prizren moved northwards and settled in the plains and valleys of eastern Shumadya. The Macedonians moved along the Vardar and Morava valleys and, with the Serbians of the old districts, crossed the Sava and Danube and settled in Styria, southern Carniola and Croatia. Among the Bulgarians, the *Balkanyis* alone left their mountains for the lower Danubian or the fertile Thrace plains. The Albanians often changed place. Pushed back from the Black Drin by the Slavs in the 6th and 7th centuries, most of them adopted the creed of the Turks in the Middle Ages, and travelled freely through the whole peninsula; the half-Serbian, half-Albanian Malisors settled at Novibazar; a few Miridites pushed up to Kosovo; the central Albanians to near Skoplye and Tesovo; the southern Albanians to the Peloponnesus. Along the main roads are Greek commercial colonies and Turkish military posts. The gradual clearing of the peninsula caused metanastasic movements of the Turks back towards Constantinople and Asia, and of the Christians back to the homes of their ancestors. The Turkish domination was responsible for many migrations: after revolts, and every fourth year as one-fifth of the young Christians entered the Sultan's service as *Yenitseris*, entire families took refuge in the high *massifs*. During the wars between the Turks and the Austrians in the 18th century, the Serbian insurgents, to avoid reprisals, had to follow the retreating Austrians. During the liberation wars led by the Kara Georgevitch in 1804 and by Milosh Obrenovitch in 1815 many Serbians migrated from Novibazar and Nish into Shumadya. Economic conditions also played their part in those movements: entire families left overcrowded cultivated areas for rich but less inhabited areas. Scarcity of food pushed 10,000 Montenegrins eastward into Serbia in 1890. Many *kmets*, trying to escape bad conditions of tenure, obtained land in the newly liberated territories. Those metanastasic movements brought about the redistribution of ethnic and religious groups, and extended the Orthodox Church into the domain of the Roman Catholic, north of the Sava and Danube. In the same way, the Dinaric dialect pushed back the Croatian, and the Kosovo dialect was spoken farther and farther northward. Everywhere the immigrants adapted themselves to the life of the inhabitants among whom they had to live, but also brought new customs and a new mentality.

*Races*.—Owing to the continual movement of the population, the ethnological boundaries do not coincide with those of the great natural regions. The Greeks came from Asia Minor in early historic times and settled in the coastal area, including the islands between Varna and Corfu. They assimilated the Romans in Byzantine times, the Slavs in and after the Middle Ages, the Aramuni from the 12th to the 15th century, and the Albanians after the 14th century. But even now their range does not extend far from the sea, its northern boundaries being the southern border of Albania, the river Bistritsa and Lake Beshik. Farther east, mixed up with Turks and Bulgars, and with many Greeks in such commercial centres as Constantinople, Adrianople and Salonika, they occupy Thrace equally with the Turks. In the peninsula and adjacent islands they probably number 4,500,000.

Declining since the 17th century, the Turkish population has disappeared from the northern towns and from the Rhodope and Balkan mountains, where names given by Yuruk shepherds are, however, still retained. The Turkish element is nowhere found in compact masses except in the east Balkanic regions; where the dry climate is similar to that of Asia Minor. Elsewhere, it exists only in isolated districts—in eastern Bulgaria, in Thrace, on the left bank of the Vardar and in the Bujak-Kajlar basin. The total Turkish population of the peninsula scarcely exceeds 1,800,000.

The Albanians or *Shkipetar*, representatives of the primitive Illyrian tribes, were not Slavized like the Dalmats or Liburns. They live in the mountainous Pindus and Prokletye, encompassed by Yugoslavia and Greece, while, among them, the Slavs



## BALKAN PENINSULA



FIG. 4.

often occupy the valleys and littoral plains. They have lost ground in the north-east since 1878 and the withdrawal of the Sultan's authority.

The Aramuni, numbering approximately 160,000, are found in 154 detached settlements of the southern peninsula. They are nomad shepherds migrating between the mountains and the littoral plains. Remnants of the primitive Latinized population, they have continued to decrease since the 18th century, when it is estimated they numbered 500,000. Some of them have settled in the mountains after having made money as shopkeepers in large towns.

The Yugoslavs, numbering about 15,000,000 south of the Danube and Sava, are the most numerous people in the peninsula. They are divided into Serbo-Croat-Slovenes (10,000,000) and Bulgars (4,700,000), all agriculturists. The majority of the Serbs, Croats and Slovenes came from trans-Carpathian countries in the 7th century. The distinction between them does not arise from any linguistic, racial or even religious difference. The national spirit of the Serbs gained force after the battle of Kosovo in 1389. At the end of the 15th century, the Orthodox

religion, diffused through the Serbians after metanastatic movements, became national, and it helps to maintain unity. The Serbo-Croat-Slovene Kingdom, generally called Yugoslavia, does not include all the Serbians, Croats and Slovenes of the Balkan Peninsula—more than 400,000 were annexed to Italy by the Treaty of Rapallo. The Macedonian Slavs extend southward to Hellenic territory, almost to the river Bistritsa.

The Bulgars, who descend from a fusion of the Slavonic element with a later Ugro-Finnish immigration, inhabit the kingdom of Bulgaria, parts of Dobrudja and Thrace. On account of the proximity of Constantinople and of the general geographical conditions, they were more submissive to the Turks than any other part of the population, so that the word "Bulgar" often meant a social state different from that of the Turkish conquerors. Its political meaning dates from the creation of the Exarchat in 1870 and the wars of liberation.

The remainder of the population is composed of Armenians, who live in trade centres like Constantinople; of Jews, immigrants from Spain who form half of the inhabitants at Salonika; and of gypsies, wandering, or in scattered settlements near large towns.



not quite twice that of a Turkish. The infantry strength of II. Ban divisions varied, but was usually three 4-battalion regiments. A number of supplementary regiments were formed from excess reservists, III. Ban units, for subsidiary operations. There was a cavalry division. At the completion of mobilization the ration strength of the field forces alone, exclusive of III. Ban units, was 287,000, almost exactly 10% of the population. In the whole war some 450,000 men are supposed to have been mobilized.

**Greek Army.**—Four active divisions of 9-11 battalions each (equal in number of units, and superior in effective numbers, to a Turkish division). Reserve units forming four weak divisions, each equal to two-thirds of a normal division. One cavalry brigade. Ration strength of the field army, about 110,000.

**Montenegrin Army.**—A militia organized in four divisions of varying strength. Approximate total of field troops 47,000.

With regard to the proportioning of effort between the two theatres of war, contemporary military opinion, impressed by a sort of primacy which Bulgaria assumed in the league, by the more regular character of her army and her civil administration, and by the nearness of Constantinople to her eastern frontier, argued a priori that Thrace was not only the "principal" theatre, but the single important theatre in which practically all military effort should have been concentrated by both sides—a judgment which ignored the relation of strategy to war policy, and one for which in the sequel Bulgaria was destined to pay heavily. For the objective of the war was Macedonia, as von der Goltz had foreseen in 1909 when he increased both the present and the potential strength of the Turkish forces allotted to that theatre. And when conquered, Macedonia would be conquered once and for all, for the possibility of a Turkish counter-offensive to recover the lost province was excluded by the Greek navy as effectually as the possibility of reinforcing Tripoli had been excluded by the Italian navy in 1911. A further important consideration for the allies was the obscurity of the ethnographic lines in central Macedonia. Here the population was neither definitely Bulgarian nor definitely Serbian, and unless the two allies concerned were both represented in the conquering army the absent member would certainly suffer when it came to drawing the frontier-line.

On the other hand, each of the allies had special objects which might, and in some cases did, conflict with the common object. Bulgaria cherished ambitions in Thrace which extended even to Constantinople, and she had to consider the fact that sooner or later the Turkish forces in Thrace would be reinforced not only by their own allotted reserves but also by those, above alluded to, which the Greek navy prevented from going to Macedonia. Further, Bulgaria coveted not only a coast-line on the Aegean but the great port of Salonika itself.

Serbia, on her side, had to consider not only central Macedonia but northern Macedonia and the Sanjak of Novibazar. These provinces would infallibly revolt against the Turkish authority as soon as the Turkish forces withdrew to concentrate for battle in the S., and unless *bona fide* troops of the Serbian Government came to occupy the country, a state of disorder would arise that would equally certainly invite Austrian intervention.<sup>1</sup> Further, Serbia was determined to carve for herself a way to the Adriatic through northern Albania. Greece for her part had a minor objective in Epirus—a region of which the northern limit was vague—and as a major objective Salonika and the Aegean littoral beyond, not to mention more remote objects in Asia Minor.

Montenegro's aims were limited to local expansion southward into Albania and eastward into the Sanjak of Novibazar and northern Macedonia; in both of these directions some conflict of interest with the Serbian Government might arise.

All these things were, in their varying degrees, elements of policy upon which the Allied strategy must base itself if its war aims were to be obtained, and accordingly the military treaty between Bulgaria and Serbia provided for a Serbo-Bulgarian army of 7 Serbian and 3 Bulgarian divisions to invade Macedonia, moving concentrically against the front Uskub-Kumanovo-Kratovo-Kochana, forming the outer contour of the plain known as Ovche Polye which was assumed on both sides to be the natural concentration area of the Turks.

If the road system was judged by the staffs sufficient to permit of the augmentation of the left wing, this was to be made up of 2 Serbian and 3 Bulgarian divisions—a force equivalent to 10 Turkish divisions, while the other 5 Serbian divisions (equal to about 8 Turkish) descended from Vrnanya upon Kumanovo. If not, the central mass of 5 Serbian divisions was to be flanked on the N. by 2 divisions moving by the Kara Dagh on Uskub and on the S. by the

<sup>1</sup> The navy consisted of the "Georgios Averof," a powerful armoured cruiser, 3 old coastal battleships practically modernized, and 16 modern destroyers and other torpedo craft, including a submarine; as against the Turkish strength of 3 small battleships (ex-German), one modernized coastal battleship, 2 light cruisers and 20 effective destroyers and torpedo boats.

<sup>2</sup> The relations of Serbia and Montenegro were not such that the Serbian Government could easily hand over to Montenegro the entire responsibility for the conquest of the north.

3 Bulgarian divisions advancing on the front Kratovo-Kochana. In both cases the envelopment of all the forces that the Turks could gather for battle was the object aimed at. It provided also that if the military situation in Thrace required it, troops not indispensable in Macedonia might be transferred thither, and vice versa.

The balance of the Serbian forces (about 3 divisions) were at the free disposal of their Government, and in fact were intended for the conquest of the Sanjak of Novibazar.

The 6 (or 7) Bulgarian divisions remaining were to form the army destined for Thrace.

The rôle of Greece, when she acceded to the league, was by offensive operations from Thessaly to bind as many hostile troops as possible, incidentally occupying the country which it was intended to acquire. The Greek navy was to close the Aegean to Turkish transports. A minor Greek force in the Epirus theatre, and the Montenegrins in northern Albania, were similarly to absorb the attention of the Turkish garrisons (3 independent divisions) and to conquer territory.

On the very eve of operations, however, a drastic change was made (Sept. 28) at the instance of Bulgaria. Instead of 3 divisions, 1 only was to operate in Macedonia, and this was directed to move independently from Dupnitsa in the direction of Seres and Salonika. The striking wing of the allied army—that which, directed upon Shtip, would have come in upon the rear of the Turkish positions on the Ovche Polye—was thereby deprived of a force of about 80,000 men. And Bulgaria, by evading at the last moment an obligation that was not merely part of a military scheme but was included in the basic political treaty of Feb. 29 1912, set up at once an atmosphere of friction which was not likely to help her in her claims to the doubtful districts of Macedonia. Serbia, submitting rather than agreeing, redistributed her forces, and the strategic deployment and order of battle actually carried out was as follows:—

Commander-in-chief, King Peter

Chief of the general staff, Gen. Putnik

II. Army	Gen. Stepanovich (28,000 ration strength)	Timok I. <sup>2</sup> and Army troops.
I. Army	Crown Prince Alexander (126,000 ration strength)	Morava I., Drina I., Danube I., Danube II., Timok II., Cav. Div., Army troops.
III. Army	Gen. Yankovich (67,000 ration strength)	Shumaja I., Morava II., Drina II., Morava Brigade, Army troops.
Ibar Force	Gen. Zhivkovich (18,000 combatants)	Shumaja II., Army troops.
Yavor Brigade	Col. Angelkovich (9,000 combatants)	(1 mixed brigade).

The I. Army was cantoned in the Morava valley, about Vrnanya, with outposts on the frontier. The II. Army on its left (now reduced to one division) was concentrated along with the 7th Bulgarian Div. about Kyustendil, and the III. Army on its right, behind the frontier, on the various mountain routes E. and N. of Prishtina. The Ibar Force lay on the river of that name, just inside Serbian territory, opposite Novibazar. The Yavor Brigade was temporarily held back facing the Serbo-Bosnian frontier. The intention was that the III. Army should advance first and make good possession of Prishtina, and then turn S., leaving one division to hold the captured territory, and with the remainder advance rapidly S. through the Kachanik defile on Uskub, the unattached brigade meantime opening up communication over the Kara Dagh with the Central (I.) Army. This would have initially the difficult task of debouching from the narrow front of the Morava valley, while the sole remaining unit of the II. Army was to advance by Egri Palanka towards Kratovo.

The Ibar Force, and eventually the Yavor Brigade also, were to clear the Sanjak of Novibazar of Turkish garrisons and Albanian bands. The Montenegrins were to cooperate to some extent in this task, but their main effort was to be directed against Scutari.

Mobilization began in all the countries affected on Sept. 30-Oct. 1. Montenegro was the first to declare war, on Oct. 8. Ignoring the declaration of the Great Powers that "under no circumstances would they agree to any change in the *status quo* in S. E. Europe," the other three members of the league presented a joint ultimatum on Oct. 13. Turkey rejected this on the 15th, and on the 17th war was declared. By that date the movements of strategic concentration were nearly complete, and several frontier skirmishes had already taken place.

**II. The Campaigns in Macedonia and the West.**—On Oct. 20, while the Serbian I. and II. Armies closed up on their advanced elements (the I. clearing some high ground beyond the frontier to facilitate the next day's work), the III., which had the greatest distance to cover, marched in several columns on Prishtina. Irregular fighting on difficult ground brought the army close to Prishtina by the 22nd, and the Turks evacuated the town on the evening of that day.

On Oct. 21, the I. Army advanced in three columns: Morava I., Timok II. on the right, with flank guards in the Kara Dagh, fol-

<sup>2</sup> The 7th Bulgarian Div. was nominally under the orders of this army, but in fact obeyed orders only from the Bulgarian headquarters.

lowed the Moravitsa valley; Danube I. and Danube II., on the left that of the Pcinja; while Drina I. moved along the watershed between these rivers. The cavalry division was kept back till the infantry should have gained ground in the plain. The II. Army moved on the same day, but very slowly, along the Kysentid-Egri-Palanka road, with instructions to advance thence both on Stratin (Stracin) and on Kratovo, gaining touch with the I. Army W. of the former place. Bulgarian coöperation was limited to a movement by one brigade over the mountains towards the upper Bregalnitsa. The rest of the 7th Div. frankly began its march over Jumaya Pass into the Struma valley, heading for Seres.

That evening, without having obtained touch either with the II. or the III. Armies, the I. Army halted on the line Tabanovche-Star-Nagorichino, disposed in depth and entrenched, with orders to stand fast on the 22nd and wait developments on its flanks. Resistance so far had been slight, but on the 22nd Turkish forces of some strength were reported at Kumanovo.

The Ovche Polye was, after all, not to play the part of Königgrätz. At first, it seems, the Goltz plan of a defensive concentration there, to be followed by radial attacks on divided enemies, was adhered to by the Turks. But when at the last moment it became clear that the Bulgarian effort was concentrated on Thrace, 'Ali Riza Pasha, commander-in-chief in the Macedonian theatre, was ordered to take the offensive. Zekki Pasha, in charge of the three corps grouped in the Vardar region, was at once directed by 'Ali Riza to move forward against the Serbians as they debouched from the mountains.

Of 'Ali Riza's 25 divisions, 3 were scattered between Prishtina and the Austrian frontier, 3 at Scutari, 4 at Dibra, and 1 at Prizren; 2 opposing the Greek main army in Thessaly and 2 the Greek secondary army in Epirus; 3 in the Struma valley and 1 guarding the railway between Veles and Salonika, making, in all, 16 which were totally unavailable for battle in the decisive theatre.<sup>1</sup> Of the remaining 9, 1 was at Prishtina, 2 in the valleys of the Bregalnitsa and the Zietovska facing Kocjana and Kratovo, and 6, forming the main group under Zekki, advanced across the Ovche Polye on the 21st and 22nd, the V. Corps then halting N. of Novoseljan, the VI. N. of Slatina and the VII. N. and N.E. of Kumanovo.

Viewed as a whole, 'Ali Riza's forces, scattered as they inevitably were through the need of holding territory, were reasonably well distributed, in that, though the Turks were in the ensemble inferior in the ratio of 1 to 2, their handicap on the decisive battlefield reduced itself to the ratio of 1 to about 1½. Had still further economies been practised (in the Struma valley for instance) this handicap might have disappeared. But uncertainty as to Bulgarian movements and dispositions was not yet cleared up. In any case, the seizure of the initiative at a moment when the Serbian I. Army was still cramped and out of touch with its neighbours went far to neutralize the numerical disadvantage.<sup>4</sup>

As a matter of fact, Zekki intended to use the day of the 23rd for closing up his columns and narrowing his front; and, Prince Alexander's intentions being the same, the day would have been uneventful but for the initiatives of subordinates on both sides.



The Serbian Danube I. Div., on the evening of the 22nd, had been tempted to go forward, out of alignment, by the evident tactical advantages of a position farther south. On the morning of the 23rd it was formed in an arc facing S. and S.W., with its left flank on the Pcinja, near Voynik, its centre looking towards Slatina and its right on hill 650, and in that position it was attacked by the heads of 4 Turkish divisions. A fierce battle raged all day on this front, while the other 2 Turkish divisions (VII. Corps) engaged Morava I. N. of Kumanovo with indecisive results, and the remaining Serbian

divisions, Drina I. in the centre, Timok II. behind the right and Danube II. behind the left, remained practically inactive, partly in ignorance of what was taking place (the Army Command itself was in the like case), partly because strict orders had been given to stand fast during the 23rd. Only Drina I. came into action towards evening, and the situation was critical when fighting died away and army headquarters at last became aware of the facts. During the night the remaining divisions were urged forward to the battlefield.

Next day they came progressively into action. The stubborn resistance of Danube I. had shaken the attacking power of two-thirds of Zekki's force, and the intervention of Danube II. and the Serbian cavalry division on the 24th completed the work, after hard fighting beyond the Pcinja. And when a few advanced troops of the II. Army from Egri Palanka reached the outskirts of the battlefield, the V. and VI. Turkish Corps, fearing to be enveloped, retreated southward into the Ovche Polye. In the centre, Drina I. drove forward far into the weakest part of the enemy's system. On the Serbian right, the Turkish positions between Cerno Polye and Lopkovo in the foothills of the Kara Dagh fell to the attack of Morava I. and Timok II. in the afternoon. With a loss of some 4,500 killed and wounded (nearly half of these in Danube I.), the Serbians had won the first great battle of the campaign. But it was not a *bataille sans lendemain* as the Serbo-Bulgarian convention had intended it to be. Neither the III. Army, which coming in from Prishtina was still two days' marches distant, nor the II., which consisted effectively of one division only, could help to make it so. And in consequence no real pursuit was made, the I. Army halting and encamping on the ground it had gained. Actually, a pursuit would have closed the campaign, for the Turkish retreat had converted itself into a rout. Even Uskub was evacuated, and the force barring the Kachanik defile against the III. Serbian Army withdrawn.

For some days the Serbian G.H.Q. continued to keep a tight rein on its armies, grouping them principally for a battle against the "Turkish main army" presumed to be about Veles-Shtip. The cavalry division advanced to St. Nicholas, a point equidistant from these two towns, while Timok I. (II. Army) passed Kratovo and moved on Cerni Vzh, which was not captured till the 26th. The I. Army followed carefully to the latitude of Gradishte, while the III., parts of which—for the sake of earlier contact with the I.—had used routes E. of Kachanik that had now become eccentric, moved up slowly on its right. Drina II. was left at Prishtina to secure the country and cooperate with the Ibar Force, while Uskub was held by Morava I. So difficult was the country and so imperfect the liaisons that it was not till the 29th that the deployment of the I., II. and III. Armies across the Ovche Polye was complete.

By that time the Turks had long evacuated the right bank of the Vardar. The remains of the VII. Corps from Uskub had gone to Tetovo and part of the V. Corps had retreated down the Vardar, but the bulk of the V. and VI. Corps had retired through Veles towards Monastir and were preparing to offer a new resistance in the Babuna Pass.

But the Serbian G.H.Q. had now gleaned many details of the Turkish rout, and, assuming Zekki's army to be reduced to a remnant which could be crushed between a single Serbian army and the Greeks, it made entirely new dispositions on the 29th. To aid the Bulgarians in the siege of Adrianople, it sent the II. Army, and actually added to it Danube II. in replacement of the Bulgarian 7th Div. which continued its way down the Struma.

To penetrate Albania and gain the desired foothold on the coast, the III. Army (reduced to Drina II. and Shumaja I. and army troops) was sent eastward on Oct. 31.

The I. Army, now consisting of Morava I., Drina I., Danube I., Timok II., Morava II. and the Morava Brigade, was to pursue the Turkish army and complete its ruin, in coöperation with the Greeks.

Meantime, the conquest of the Sanjak of Novibazar and of northern Kosovo had been practically completed. From Oct. 10, Montenegrin forces under Gen. Vukovich had been operating from the inner part of their country towards Plevlje, Byelopolye, Berane, and Gusiñye. On the 19th, the Ibar Force under Zhivkovich (Shumaja II.) had advanced in several columns which, with more or less irregular fighting and one or two critical moments, had converged on the town of Novibazar and captured the Turkish works on the surrounding heights by the evening of the 22nd. On the 23rd, Novibazar was occupied, and the work of hunting down the dispersed enemy and their Arnaut auxiliaries began. On the 28th a force from Novibazar, in concert with a detachment of the III. Army from Prishtina, captured Mitrovitsa. In the extreme N. the few Turkish troops available were forced, under pressure from the Montenegrins and the Serbian Yavor Brigade, to concentrate at Plevlje; there they were attacked on the 29th and driven over the Austrian border. On the 30th Ipek (Pech) fell to the Montenegrin southern columns. Thenceforward the troops in these regions were only employed on police duties; but their withdrawal to other theatres of war was, in view of a possible intervention by Austria-Hungary, considered undesirable.

The Greek campaign opened on Oct. 18. The 4 active divisions of the Greek army and 3 of the new divisions (5th, 6th, 7th) formed the main army in Thessaly under the Crown Prince Constantine, whose chief-of-staff was Gen. Danglis. The 8th and 9th Divs., composed almost entirely of reservists and volunteers, constituted the Epirus Army under Sapundjakis.

<sup>1</sup>These outlying divisions are catalogued here as such. But their strengths were in reality very unequal.

The Turkish force opposing each of these amounted to about 2 divisions. So small an allotment on the Thessaly front can only be explained on the assumption that the Turks supposed the Greeks to be at the same level of efficiency as in 1897. If so, they were deceived. From Trikala the Greek 5th Div. moved on Diskata and the upper valley of the Vistriza. Two divisions (2nd and 3rd) advanced into the salient W. of Tyrnavos and occupied Damasuli, and moved N. to clear the way for the 1st and 4th Divs., which from Tyrnavos moved directly on Elassona by the Meluna Pass. The 6th and 7th Divs., still imperfectly organized, followed on in second line.

On the 19th Elassona was captured with little difficulty, the main Turkish position lying farther N. in the defile of Sarandoporon which traverses the mountains lying between the Xeria and the Vistriza basins. On the 20th and 21st, the Greek divisions, which had converged on Elassona for the battle that had been expected there, were redeployed, and on the 23rd the attack was delivered by all five. The 5th from Diskata and the 4th from the Xeria, uniting in the Vistriza valley, marched on Serfije, throwing out a flank guard to Grevena, while the 1st, 2nd and 3rd Divs. attacked the defile frontally and threatened its rear by way of Vlaholivadia. The much smaller Turkish force was routed with a loss of 20 guns and many prisoners, and (what was more important) the Greek army gained self-confidence as well as local victory, at a cost of some 1,300 casualties. Part of the beaten force retreated from Koziani on Monastir, the remainder on Verria, and the Crown Prince occupied Koziani on the 25th.

In view of the urgency of occupying Salonika before the Bulgarians arrived, the Crown Prince decided to leave only flank guards (5th Div. N. of Koziani and light troops N. of Grevena) facing the Monastir direction, while the remainder, reinforced by the 6th Div., pushed on to Verria, and the 7th Div. worked along the coast towards Katerini. These moves were successfully carried out; the 7th Div. gaining touch with the fleet on the 28th, occupied Eleutherochori and there created a new base, while from Verria the main army turned sharp N. and seized Vodena, the 5th Div. at the same time advancing to Banitsa by Khailar. This ingenious manoeuvre placed the five divisions of the main body on interior lines with a base on the sea and a strategic flank guard on either hand (Nov. 1). But the situation was nevertheless critical for the Greeks, for Hasan Tahsin had drawn in forces from the Struma valley and was in position facing W. at Yenije Vardar, while Djavid Pasha at Monastir had assembled an effective force from troops that had come in both from the Kumanovo and the Sarandoporon battlefields, and was moving out to attack the 5th Division. The Serbian cavalry descending the Vardar had not yet passed the defile of Demir Kapu. The Serbian armies were being rearranged for the new movements above detailed, and even the I. Army was scarcely beginning its movements against the Babuna Pass. As to the Bulgarian 7th Div., the last thing desired by the Greek headquarters was an energetic advance of this force to forestall that at Salonika.

On Nov. 2 and 3, while Constantine attacked the Yenije Vardar position without success, Djavid fell upon the 5th Div. and drove it with heavy losses to Khailar. Simultaneously, the Greeks from Grevena, who had reached Kastoria, were forced back. But on the 4th, before these flank guards had been sufficiently beaten, the 7th Div. from Eleutherochori had forced the passage of the Kara Azmak and were threatening to interpose between Hasan Tahsin and Salonika. A renewed frontal attack at the opportune moment broke into his position at Yenije Vardar, and, threatened on all sides, the Turks withdrew into Salonika, where their commander and 29,000 men surrendered to Constantine on the 9th.

Next day the 7th Bulgarian Div.<sup>1</sup> arrived and claimed the city for Bulgaria. An open rupture between the allies was only avoided by the establishment of a *condominium*.

The Greek army was then regrouped. The 1st, 2nd and 7th Divs. remaining for political reasons E. of the Vardar, the 3rd, 4th and 6th Divs. were concentrated at Vodena, with the 5th at Khailar and the Grevena force on the Kastoria road, in readiness for an advance on Monastir in concert with the Serbian I. Army.

This army had begun its advance on the mountains surrounding the basin of Monastir on Nov. 1, Morava I. and Drina I. moving directly from Veles, and Danube I. from Shtip by Krivolak<sup>2</sup> on Prilep, while Morava II. from Tetovo marched S. on Gostivar. On the Prilep and Kichevo routes respectively, the Turkish V. and VII. Corps were rallied to dispute the passes while the VI. Corps assembled at Monastir.<sup>3</sup>

The forcing of the Babuna Pass above Prilep was a long and difficult business, which fell on the central column alone, as Danube I. and Timok II. had to await bridging equipment before they could cross the Vardar. It was not until Nov. 5 that Prilep was reached,

<sup>1</sup> This, as has been mentioned already, moved down the Struma valley, with a detachment on that of the Bregalnitsa. The latter rejoined by way of Strumitsa, in the last days of October. Another detachment by the Mesta valley, marched on Drama. These columns met with no serious resistance.

<sup>2</sup> Whence the cavalry with infantry support was sent to seize Demir Kapu.

<sup>3</sup> Part of this force took a share in the attack on the 5th Greek Div. at Banitsa.

and then a further pause was thought necessary to reassemble the units, scattered by mountain fighting, as well as to allow the two flank columns to come up. On the same day, however, hearing of the crisis on the Greek front, and arguing that it was both necessary to relieve pressure on the 5th Greek Div. and also possible to advance without undue risk against the Turks remaining in front of Monastir, the Serbian G.H.Q. ordered a tentative offensive towards Alince. This, carried out on the 6th by a part of Drina I., soon developed into an unintended battle, in which Morava I. and the cavalry division<sup>4</sup> were called on to join. But the result of a day's fighting, which was marked by initiative and combination of effort in the subordinate commanders, was to hustle the Turkish V. Corps back to the environs of Monastir. A rash advance of the two divisions into the midst of the enemy was only prevented by stringent orders from G.H.Q. to halt and await the coming of the two flank columns. Of these, Morava II. had successfully driven back the Turks from Kichevo on Nov. 5, but was obliged to halt in order to organize its line of supply Gostivar-Tetovo-Uskub, and the left column was only just beginning the passage of the Vardar at Krivolak. Skill doubtful of the real situation on the Greek front, Prince Alexander, in agreement with Putnik, was determined not to fight the battle of Monastir till he should have all his forces in hand.

The assembly of the forces for battle on the line Mramoritani-Podine—Dobrusovo was to be completed for Nov. 14.

The Turks also prepared for battle. Leaving only a few troops in front of Verria and of the Greek 5th Div. and Grevena force, Djavid Pasha brought back the rest of the VI. Corps to join 'Ali Riza at Monastir, where what remained of the V. and VII. were concentrated. The total combatant strength was about 40,000. The position taken up lay S. of the line of the Semnitsa, and thence along the marshy bank of the Cerna, its eastern half lying on the plain and its western half on the heights. The V. Corps occupied the plain from opposite Novak to Kikuricani, with its centre of gravity on the Prilep road. The VII. Corps occupied the mountain sector; and the V. Corps was in reserve at Monastir.

The Serbian plan was to attack the Kikuricani front and the heights abutting on the plain with Morava I. on the right and Drina I. on the left, to attack and outflank the Turkish left wing on the mountains by means of Morava II. which was coming down from Kichevo, and to do the same on the right of the defence with Danube I. and the cavalry division operating at and S. of Novak. Timok II. was to be in reserve behind the centre. The necessity of maintaining at all costs the single supply route of the army—that through Prilep to points on the Uskub-Salonika railway—no doubt imposed a plan of

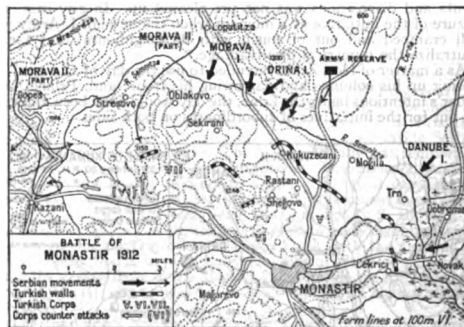

battle that was to all intents and purposes frontal, for the projected movements of cavalry on Resna and over the Cerna could hardly be regarded as serious attempt at envelopment.

The battle, projected for Nov. 14, was ordered to be postponed till the 17th. But on the 15th, as the divisions were getting into position, part of Morava II., carried away by its own ardour, launched a night attack on height 1,150 S. of the Semnitsa. The enemy was well prepared, position after position had to be stormed and it was not till the afternoon of the 16th that the detachment secured the height, at the cost of heavy losses. Meantime the rest of the army, according to orders, was merely making its final reconnaissances. On the 17th, the four battalions of Morava II. had to resist, still without help from the rest of the army, a series of heavy counter-attacks delivered by the VI. Turkish Corps under the energetic Djavid.<sup>5</sup>

The battle of Monastir, which was finally launched on the whole front on the 18th, will long be studied for its tactical incidents, but as an ensemble it is sufficiently described by saying that the resistance of the half division of Morava II. absorbed so much of the

<sup>4</sup> Which had been relieved on the Vardar by Timok II.

<sup>5</sup> Morava I., however, sent some reinforcements on the afternoon of this day







penetrated the Turkish front between Gechleulla and Seliolu) brought the Bulgarian army victoriously to the Deremanlia-Kukler-Gerdeli road by morning on the 24th. The Turks had disappeared. Owing to events on their right, they had given up their somewhat disjointed efforts to defeat the Bulgarian centre, and retired in a direction or directions which the victors were unable to determine.

Kirk Kilisse was a route-centre of importance, with a line of barrier works, partly permanent, on its N. side. Von der Goltz had intended that it should play the same part on the right flank as Adrianople on the left. Although the permanent works were few, and inferior to those of the great fortress, the natural positions afforded by spurs of the Istambul Balkans gave the place advantages of site which were lacking at Adrianople. The Bulgarians on their side, allocated a whole army to the task of dealing with it, by investment, brusque assault or regular siege, or a combination of those methods.

Partly in order to develop the necessary frontage from the outset (in case of battle between Kirk Kilisse and the frontier), and partly in order to utilize the routes to the best advantage in a country much more difficult than that traversed by the other armies, Radko Dimitriev had formed his two leading divisions into four brigade columns—(a) 4th Div. from Oyakoi to Keremetlia (liaison with I. Army); (b) 4th Div. followed by part of 6th Div. by Devletli Aghach and Eski Polos on Petra; (c) 5th Div. with remainder of 6th Div. from Malkochlar by Eriker on Raklitsa and Kirk Kilisse; (d) 5th Div. from Topchular by Almajik on Kadiköi. Of these columns (a) became involved in the Seliolu fighting, and took no part in that of Kirk Kilisse.

Columns (a) and (b), forming the strongest part of the army, and also column (c) soon met with strong resistance (morning 22nd), and the country, the weather (stormy since the 20th) and tactical incidents making progress uneven, the front at nightfall of the 22nd was very short, the Turks holding pronounced salients at Eski Polos, and also at Almajik, while the Bulgarians had penetrated nearly to Kadiköi in the centre and within 2 m. of Petra on their right. On the 23rd, however, continued pressure on the Kadiköi and Petra fronts forced the Turks to evacuate their salients, and at night the Bulgarian line, with its flanks somewhat advanced, ran roughly E.W. from the heights S.S.W. of Petra, through that village, to height 1,506 N. of Akmachia and thence some distance south-east. From this line, in the night, assaults by parts of the two left columns (5th Div.) penetrated to Karaköi on the one hand and halfway to Raklitsa on the other. And thereupon, worn out by two days' hill fighting and lacking in internal homogeneity, Mahmud Mukhtar's Corps broke up, abandoning Kirk Kilisse and its fortifications, and streamed away in panic. The Bulgarians entered Kirk Kilisse on the 24th and possessed themselves of immense booty, including 55 guns.

Mystified and ignorant of the line of retreat of the enemy, both the I. and III. Armies stood fast on the 24th on their respective battlefields, while the cavalry division was sent out due south. On the 25th the horsemen reached the Constantinople railway at Baba Eski; next, pushing reconnaissances S. and S.E., they found the country S. of the Ergene all clear, but hostile forces between Lule Burgas and Muradli. At the same time the divisional cavalry of the 5th Div. from Kirk Kilisse appears to have established the presence of enemy forces at or near Bunar Hissar.

This information, showing that the Ergene line had been abandoned, and that Abdalla was regrouping his forces and assembling his incoming reserve divisions in the Lule Burgas-Vaisa region, involved a complete change of front for the Bulgarians. Hitherto facing S., they had now to face E., pivoting on the 5th Div. at Kirk Kilisse. And while the necessary movements were being carried out, Abdalla again took the offensive, with the reorganized four active corps, and the XVII. and XVIII. Corps of new formation.

On the 27th the Bulgarian wheel pivoted, but instead of its being carried out on a fixed pivot, the pivot itself was allowed to advance eastward, so that, instead of presenting a united line, the Bulgarians formed a loose echelon, left in advance, which led to successive instead of simultaneous engagements. On the evening of that day, the Turkish III. Corps (Mahmud Mukhtar) on the right, was on the road between Vaisa and Bunar Hissar, the II. at Kara Aghach, the I. at Turk Bey and the IV. partly at Lule Burgas, partly at Sakisköi, the total front between the Ergene and the mountains being about 45 miles. The two new corps were a march in rear. A general offensive had been ordered.

On the 28th, as a natural consequence, an encounter battle began just E. of the Kara Aghach, in the forest of Sujak, between Mahmud Mukhtar's troops and the Bulgarian 5th Div., the latter finally drawing back behind the stream and occupying a line from Chiflik Teke on the left to Mura Aghach on the right. Thereupon the various Bulgarian columns echeloned back to the right of this division, hastened their march, and part of the 3rd Div. from the Adrianople region was ordered up to support the 5th directly, which by a heavy forced march it was able to do on the evening of the 29th. On the other side, confusion in the command and other causes made the general advance slow and disjointed; the initiative was soon lost, and the battle became one of the parallel fronts along the

Kara Aghach. On the 20th (afternoon) the 4th Bulgarian Div. followed by the 6th were already on that line. On the 30th, the crisis of the battle, the I. Bulgarian Army came into action opposite Lule Burgas (1st Div.) and on S. of the Ergene (10th Div.), while the cavalry returning from Rodosto formed up in advance of the

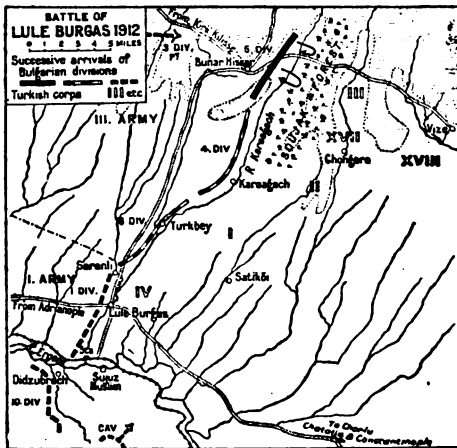

right flank of the 10th Division. At the same date, the III. Turkish Corps opposite Bunar Hissar and the XVII. Corps on its left, supported by parts of the XVIII. Corps, were still exchanging attacks and counter-attacks with the Bulgarian 5th Div. and part of the 3rd about the W. edges of the forest of Sujak. Against the Bulgarian 4th Div. on both sides of Kara Aghach village, was the II. Corps, against the 6th, about Turk Bey, the I., while the Turkish IV. Corps held the line at Lule Burgas and down to the Ergene against the Bulgarian I. Army. Of this army, however, one division only was involved in the frontal fight, and it became evident to the Turks in the afternoon of the 30th that enough enemy forces remained over to roll up their left wing and interpose between the main body and Constantinople. Accordingly, Nazim issued orders for retreat. During Oct. 31 and Nov. 1, with various tactical incidents, of which the most important was a successful night-attack of the Bulgarians at Turk Bey, the Turks disengaged themselves, beginning from the left, and by the 2nd the three corps on the right were also in retreat.

The victors were too much exhausted to pursue, and again the Turks vanished. The Bulgarian losses out of perhaps 110,000 combatants numbered 15,000; those of the enemy, whose force was probably rather less, are not known with certainty, but are supposed to have been about 25,000 inclusive of prisoners.

Without further resistance the Turks retired into the famous Chatalja lines, a well-fortified position between Lake Derkos on the Black Sea and Büyücekmeje lake on the sea of Marmora. However weakened by losses, they could hardly fail to maintain so short and strong a line as this.

On their side, the Bulgarians were tired, far ahead of their supply depots, and losing more and more men daily from sickness. On the other hand, drafts had come up, the 9th Div. replaced before Adrianople by the new 11th joined the III. Army, and the combatant strength of the two armies together was about 140,000. Made optimistic by victory, Savov and his generals determined to storm the Chatalja lines by open force. So confident were they that Savov himself said: "in a week we shall be dining in Constantinople."

On Nov. 17, the Bulgarian infantry advanced and drove in the Turkish outposts and on Nov. 18, the assault took place. It was completely repulsed, with heavy losses, and the Bulgarian command, sobered, took care not to waste its reserves in renewed assaults. Armistice proposals were already under discussion, and the battle was broken off in the afternoon of the assault. On Dec. 3, without further fighting on the Chatalja front, a general armistice was signed, more favourable to the Bulgarians perhaps than their military situation warranted, for it gave them the use of the railway through Adrianople without allowing the Turks to revictual that place.

While the main Bulgarian armies were fighting these battles, the 2nd Div. penetrating the difficult Rhodope country had carried out a vigorous offensive in several directions, as the result of which Adrianople was invested on the S.W. side, Demotika and the coast from Xanthi to Dede Aghach occupied, and two Turkish divisions de-

<sup>1</sup> This is all the more remarkable as the Bulgarian I. Army's movements were hampered by fears of a crisis at Adrianople, where a serious sortie-battle was being fought at the time. *Op. Dig.*

<sup>2</sup> Which also received the 3rd Div. from the I. Army in exchange for the 6th.

stroyed in a series of "drives" which ended in the fall of this force being surrounded and forced to capitulate at Ferejik (Nov. 27). (C. F. A.)

IV. Operations in the Spring of 1913.—The London negotiations of Jan. 1913 were abruptly brought to an end when Enver and the Young Turks, fearing that the Government would, under European

At the outbreak of the war the Turkish garrison was under Hasan Riza Bey, consisted of about 14,000 men (chiefly of the 24th Div.), to which were added, at the last moment, a reserve division from Elbasan under command of Esad, 10,000 strong.

With a force such as this, containing few active elements, only a purely defensive policy was possible. The fortress artillery was weak in numbers and out of date; consisted (at a generous estimate) of 70 guns (including the divisional field artillery), of which the heaviest were the 12-cm. naval howitzers.

The Montenegrin army stood on Oct. 7, the eve of the declaration of war, as follows: The main body under Crown Prince Danilo (2nd and 3rd Divs., less 9th Bde., 13,000 men and one battalion 12-cm. siege artillery), near Podgoritsa (Podgorica). The southern detachment under Gen. Martinovic (1st Div., 8,000 men and three battalions, 12-cm. guns, one battalion 15-cm. howitzers and two battalions 21-cm. howitzers) was near Virpezar and Antivari. The remainder of the army (4th Div. and 9th Bde., 10,000 men, and three mountain batteries) was at Andrijevitsa (Andrijevica), ready to advance into the Sanjak of Novipazar. The operations of this force are described elsewhere.

The advance on Scutari began on the morning of Oct. 9. The wide separation of the two Montenegrin columns offered the Turks a tempting opportunity of manoeuvre on interior lines, but, for the reasons given above, Hasan Riza was obliged to refrain, and the Montenegrin northern group broke through a series of passively defended positions one after the other. They were, however, so disordered by their victory that they were compelled to halt and rest. On the 10th they recommenced their advance, moving very slowly, and on the 25th halted once more on the Kiri on coming under the fire of the artillery of the fortress. Not until the 28th had they completed their bridging operations; the 2nd and 3rd Bdes. then without awaiting the arrival of the main body carried the hill called Great Bardanjolt. A Turkish counter-attack on the 30th threw them back, inflicting such heavy losses that the Montenegrins fell back to Vratsa and undertook no further advance till February. The group, which had evidently been clumsily led, took up a position between the Kiri and the Lake of Scutari, some 3,000 yd. in front of the Turkish defences.

The Montenegrin southern group moved on Oct. 9 with its 1st and 3rd Bdes. from Antivari to Katrkol, and with the 2nd Bde. from Virpezar along the shore of the lake, both columns meeting with practically no opposition. They then prepared to attack the Turkish advanced position on hill 661. Their siege artillery opened fire only on Oct. 22, and the Turkish forward line was stormed next day with heavy loss. The assailants now found themselves close up against the main defensive line. The northern group having at this time just been driven off the Great Bardanjolt, co-ordinated attack by both groups was no longer to be thought of. The southern group therefore remained waiting in the position it then occupied.

On Nov. 19 Vukotic, his work in Novipazar completed, arrived with 6,000 men to reinforce the besiegers of Scutari. He himself took

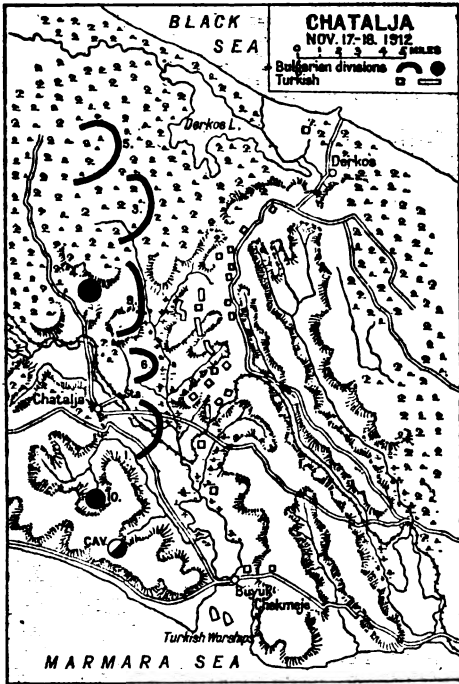

pressure, make peace practically at any cost, carried out the coup d'état of Jan. 23 (in which the Kiamil Government was overthrown and Nazim Pasha murdered), and denounced the armistice. Hostilities began again (with Greece they had never ceased) on Feb. 3, 1913. But they entirely lacked the vigour and dramatic interest of the first campaigns. Practically, the story of the second phase is the final instalment of that of the sieges of Yannina, Scutari and Adrianople. An effort was indeed made by the Turkish field forces in Thrace to debouch from the lines of Bulair and those of Chatalja simultaneously with a view to relieving Adrianople, but after locally heavy fighting the Bulgarians succeeded in holding their own on each of these fronts, and thereafter Adrianople was left to its fate.<sup>1</sup>

The fall of Yannina has already been mentioned. The sieges of Scutari and of Adrianople require, however, a rather more detailed account. (C. F. A.)

**The Scutari Operations.**—As has been mentioned already, Montenegro was the first to declare war. The first objective was the old Turkish frontier fortress of Scutari, situated at the point where the Drinasa river flows into Lake Scutari, and consisting only of a castle and a few field-works on the hills surrounding the town. The perimeter measured some 23 m., and the average distance of the works from the town was about two. The works had no deep ditches or sunk wire entanglements.

<sup>1</sup> Shortly before this the only important naval event of the war had occurred. On Jan. 15, the Turkish cruiser "Hamidich" had slipped out of the Dardanelles, and from that time till the middle of March she cruised in the waters between Malta, Durazzo and the Levant, raiding commerce as opportunity offered.

Meanwhile, the Turkish battle squadron came out of the Straits on Jan. 17, hoping to find the "Averof" absent from the opposing squadron in chase of the "Hamidich." The Greeks, however, had not committed the expected mistake, and after a long-range duel in which the "Averof" inflicted some damage on the Turkish battle-ships, the latter returned to the Sea of Marmora, where they remained to the end.

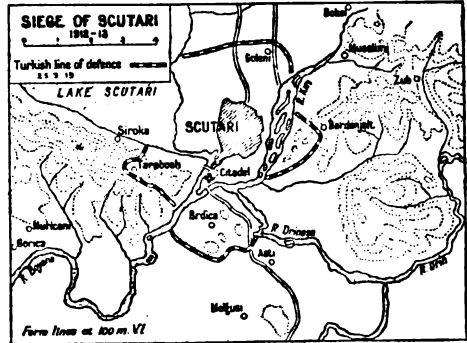

over the command of the whole Montenegrin army, his troops being distributed on both fronts.

Soon afterwards the general armistice was concluded; but Hasan refused to recognize it, as the revictualing of the fortress during the armistice had not been agreed to by the Balkan States. However, only minor skirmishes took place in December and January.

The armistice ended on Feb. 3, and shortly afterwards the attack was renewed in earnest against the Turkish strongholds of Muselimi and the Great Bardanjolt, which had been entrenched and fortified in places by blasting in the rocky soil. The assaulting columns were: (a) three battalions (1,500 men) against Muselimi from the N.; (b) five battalions (2,100 men) from the N. by hill 200 against the northern slope of the Great Bardanjolt; six battalions (2,400 men) from the N.E. against its eastern slope, and seven battalions (2,800

men) from the S.E. against its southern slope. No reserves were allotted.

The attack was delivered after an artillery bombardment of several hours on Feb. 7. The fortified post of Muselim fell with little resistance, but on the Great Bardanjolt the attack was shattered at the wire. A second assault on the 8th was no more fortunate. On the 9th however, with the aid of a Montenegrin battery that was got up to very close range, the trenches were carried after fierce hand-to-hand fighting. The assailants, who had lost 2,000 men, were exhausted.

During the next few days the captured positions were consolidated and field guns brought up. During the main attack the Montenegrins on the N. side had also pushed forward their lines from 3,000 to 1,500 yd. from the Turkish defenses. The lack of siege artillery and of unified fire direction was much felt.

Meanwhile a Serbian contingent under Boyovitch had been sent to assist the Montenegrins and complete the investing line between Drnasa and Boyana. Between their right flank and the Montenegrins on the Great Bardanjolt lay a stretch of marshy impassable country. In aid of the attack of Feb. 7 the Serbs delivered a feint-attack on the Tarabosh front, which reached the first Turkish line, but was then driven back. A small Montenegrin column also attacked Tarabosh but broke down at the wire.

South-west of Scutari there had been no change since November. The Montenegrins had made good their casualties and lay some 600 to 700 yd. from the Turkish lines, ensconced in carefully-constructed trenches in the rocks. The Turkish position here extended for some 4 to 5 m. from the strong point of Tarabosh south-eastwards to the Boyana. The besieging artillery (12-cm. guns and 15 and 21-cm. howitzers) was concentrated in two groups around Oblika and Boboti, whence it could bring a concentric fire to bear on the lofty commanding peak of the Tarabosh. The counter-bombardment of the defense was weak and practically useless, owing to slow and faulty methods of fire.

The ammunition supplies for the Montenegrins, which were sent up across the lake, were amply sufficient for all needs.

The main attack on the Tarabosh began only on March 31, preceded by five hours' artillery bombardment and by feints on the remainder of the front. During the artillery preparation, the infantry took up their positions of assault—one and a half brigades against the northern and western forces of Tarabosh, and one and a half brigades against the south.

On the latter, the assault was repulsed, completely and with heavy losses. The western attack had been more fortunate. The first Turkish position was broken through in one place, but progress was arrested by flanking machine-gun fire and counterstrokes, and everywhere the Turks held their third position firm. On April 1 the attack was repeated but with no better success, and for the next 20 days, until the capitulation, Turks and Montenegrins here lay facing one another half-way up the slope at a distance of 60 to 70 yd. apart—a situation which recalls in many respects the trench warfare days of the World War. The attack had cost the Montenegrins 1,200 dead.

The Turkish position on the Tarabosh consisted of four lines of trenches, some 30 to 40 yd. apart, and each commanding the one in front of it. The third trench line extended into the country to the east, and the fourth to the north. Behind the fourth line a 7.5-cm. quick-firing gun was posted in a shelter on the crest of the hill. In front of the first and third lines were thick belts of wire. The whole position, which was intended for occupation by a battalion, was in fact held by only 500 men.

The Montenegrins, after their unsuccessful attack of March 31 and April 1, confined themselves to the usual bombardment. The siege artillery was reinforced. The Serbian Gen. Boyovitch now took command of the besieging army, but there was considerable dissension between him and Vukotic. On April 16, however, the Serbian troops suddenly left Scutari, and the Montenegrins took over the whole line, under violent artillery fire from the Turks, who however, made no attempt at a sortie against the thin line of the besiegers. And now, when the fortress seemed quite safe from further assault, it suddenly capitulated on April 22. For some time obscure negotiations had been going on between King Nicholas and Essad, and the brave Hasan Riza Pasha, who had refused to surrender despite the shortage of food, had been assassinated. But already Montenegro was under naval blockade by the Great Powers, who had decided that Scutari should belong to the new state of Albania, and on May 6 King Nicholas yielded and withdrew his troops.

(F. C. E.)

**The Siege of Adrianople.**—In the first operations of Oct., already described, Adrianople had come within the ambit of the general battle, and it was not till after the Turks had retreated away towards the Kara Aghach line that operations in front of the fortress assumed the typical siege characters of investment and concentric attack.

The general outline of the defenses has been described above. But it is important to add that the permanent forts were old and conspicuous, and, except in a few cases when modernization had been actually begun, possessed only brick vaulting that was not proof against 6-in. shell. The only modern works were a certain number of safety-armament batteries distributed in the intervals,

of installations for 5-7 mm. close-defense quick-firing guns under armour, and of concrete shelters and magazines. The general principle of defense adopted was that common to Europe in the period before the rise of the "group" or "Feste" idea—that is, the forts were infantry redoubts for close defense and the fighting artillery was entirely in the intervals. Unfortunately for the Turks many of the "redoubts" were open at the gorge. The whole system of the main line was well worn in.

Outside the main position, and coinciding with it only on the N.E. front (left bank of the Tunja), was an advanced position, or rather a discontinuous series of field positions on selected sites astride the saddles of ground which separate the rivers (Tunja and lower Maritsa, Maritsa and Arda, Arda and upper Maritsa, upper Maritsa and Tunja). From these advanced positions the Turks had delivered the first sorties above mentioned and to them they had retired under the pressure of the II. Army's and 3rd Div.'s advance astride the Maritsa and Tunja on Oct. 22. In the days following, the 8th, 9th and 3rd Divs. extended the investment, and the 11th Div. and siege artillery were brought up via Mustafa Pasha, as well as some aeroplanes. Presently parts of the 2nd Div. lately operating in the Rhodope came up, some by the Arda and some via Demotika on the S. side. On the other hand, both the 3rd and the 9th Divs. were withdrawn to join the field army in the crisis of Lule Burgas. After establishing their line generally close up to the Turkish advanced positions (in the course of which, on Oct. 25, Kartal Tepe was captured, and Paps Tepe won and lost again), the Bulgarians sat down to await the Serbians, whose II. Army, set free by the victory of Kumanovo, was being withdrawn from the Vardar to assist their allies. Already on Oct. 27 some Serbian troops had arrived and on Oct. 31 Gen. Stepanovich took over the whole W. front of the investment with Timok I. and part of the Bulgarian 11th Div. from Tunja to upper Maritsa and Danube II. between upper Maritsa and Arda. Gen. Ivanov, commanding his II. Bulgarian Army as well as the whole siege force, had his 8th Div. between Arda and lower Maritsa and the 11th with part of the 2nd in the broadest sector, the eastern.

At this point the armistice suspended operations, but Shukri Pasha was not authorized by its terms to revivify his garrison and the defenders continued therefore to consume their resources. After hostilities were resumed on Feb. 3 it soon became evident, from attempts at sorties and from increase of desertion, that the garrison was weakening, and it was decided to force home the attack.

Want of transport resources, however, delayed the preparations till the third week in March 1913, when—parts of the 3rd, 9th and 4th Divs. having been brought into the Bulgarian II. Army from Chatalja—90,000 Bulgarian and 30,000 Serbian infantry were



actually available for the attack, which would be prepared and covered by the 125 Bulgarian siege guns and howitzers of 12 and 15 cm calibre (the latter, as mentioned above, being capable of penetrating most of the Turkish vaults) as well as some 250 or more field guns. At this period possibly 50,000 of Shukri's original 60,000 combatants were still available for duty. There were 216 field and 178 heavy guns (including some 21-cm. mortars) distributed in the defenses.

<sup>1</sup>A Turkish sortie with the intention of preventing this was, as before mentioned, repulsed.

The E. front was chosen for attack. The preliminary bombardment was carried out on March 24, and in the night of the 24th-25th the whole of the advanced line on the E. front was stormed, on a 6 m. frontage. During the day of the 25th the Bulgarians suffered a good deal in the captured positions, but Gen. Ivanov determined to push home the assault on the main position on the night of the 25th-26th, an order which involved an approach march in broad daylight and consequently heavy losses.

The assault was duly delivered in the night, and came to a standstill on the Turkish wire, save at the point where the 10th Bulgarian Regt. of the 8th Div. (brought over from the S. front for the assault) broke into Fort Ayi Yolu, the second work from the N.E. salient of Arnautk6i.

At dawn this regiment found itself isolated but in possession of the fort, and the open gorges of the row of forts tempted the audacious commander to strike out right and left along the ridge. Thus he cleared the way for unit after unit held up at the frontal wire, and, growing snowball fashion, the Bulgarian attack, soon joined by accompanying field batteries, cleared the whole line of the eastern forts by 8 A.M. on the 26th. Meantime the Serbians had captured Papas Tepe, though with considerable losses, and at other parts of the front fierce local attacks were delivered. Shaki's position was hopeless, and he surrendered about midday, with some 60,000 men and all his matériel. This great triumph cost the Bulgarians on the E. front 6,300 killed and wounded, and on the S. side 1,700, or 8,000 in all, while the Serbians lost 1,000 in the Papas Tepe sector and 400 elsewhere—a total loss to the allies of 9,400.

V. *The Second Balkan War, 1913.*—The Turkish war having again been brought to a conclusion by a general armistice, a few days after the fall of Adrianople, peace negotiations were resumed in London, and in these negotiations the settlement of peace as far as Turkey was concerned was, it may be said, the least of many preoccupations. Not only was the Balkan league on the point of internal explosion, but the Concert of Europe was trying to create the new state of Albania in the midst of a three-cornered diplomatic contest, between Austria-Hungary, Italy and Russia. Further Rumania was on the point of intervening in order to secure herself against the consequences of Bulgarian aggrandisement, and the internal politics of Turkey became more confused than ever. In these conditions the Peace of London, signed on May 30, lacked every element of reality.

Already Serbia had drawn her western forces into the Ovche Poyle area, to dispute possession of the debatable region which Bulgaria claimed, and the II. Army, which had taken part in the siege of Adrianople, was extricated as rapidly as possible lest it be isolated and disarmed in the territory of its allies. The Greeks, who had concentrated the bulk of their forces in roadless Epirus for the siege of Yanina, lost no time in getting them down to the coast and shipping them to Salonika. For their part the Bulgarians used the railway lines Adrianople-Sofia and Dede Agach-Seres (the latter secured by the conquest of the coastal region by the 7th and 2nd Divs. in the first campaign) to bring most of their forces into Macedonia.

They were deployed along a "line of demarcation" which was a battle-front in all but name. Only one division remained in Adrianople and some militia on the Dobruja frontier.

The origin of the war, as between Bulgaria and Serbia, lay in the non-observance by Bulgaria of the original treaty stipulation that she should aid the Serbian campaign in Macedonia with 100,000 men. Having failed to fulfil her part, she now claimed the territory about Uskub, Kumanovo, and Shtip in virtue of other clauses of that treaty. This claim Serbia was in no mood to concede, all the less so given her advance to the Adriatic had been forbidden by the Great Powers.

As between Bulgaria and Greece the former's claim to Salonika seems to have had no better basis than a desire to possess it. As already mentioned, the Bulgarian 7th Div., in arriving from the Struma side a few days after the Crown Prince had fought his way into Salonika from the W., had lost no time in publicly claiming ownership, and it was with hardly concealed joy that the Greek Government received and promptly executed a request to transport this division by sea to the Thracian theatre.

On all these matters bargaining might possibly have reached satisfactory solutions, since there was much to justify Bulgaria's claim in Macedonia. But the Bulgarians had skillfully exploited their primacy during the first war to induce the European press and public to regard Serbians and Greeks as mere satellites,<sup>1</sup> and, as it is not unusually the case with successful propagandists, they had come to believe in it themselves, fortified in the belief by fulsome compliments addressing them as the "Prussians of the Balkans" and the "Japanese of the West." On the other hand, the Serbs and the Greeks, thus kept out of the banquet, were not only exasperated, but sober as well. When war came in the last days of June 1913, outpost "incidents" were occurring at many points of the line from Salonika to the old Serbian frontier at Vranja. The combatants were fully deployed, and their battle was the first example of the form that has

since become typical of national warfare, the front-to-front contact along a line which stretches from neutral ground to neutral ground and shows no flank. In this instance it stretched from the Danube to the sea.

The Bulgarian scheme of operations, necessarily offensive, suffered from the weakness of having two objectives—the Ovche Poyle and Salonika—and being based on two main lines of communication diverging towards the rear—Kyustendil and Seres-Drama. It also suffered from the political necessity of avoiding the outward semblance of an aggression. The scheme, therefore, was to begin with a succession of outpost affrays along the whole line (which could be represented as a provocation suffered), and then to strike vigorous offensive blows (a) from Seres towards Salonika, (b) from Strumitsa and Radovishta against the Vardar at Krivolak and Gevgeli (Gyevgheli), (the link between the Serbian and Greek armies); and (c) a blow from the region of Kochana towards Egri Palanka. The outpost affrays duly occurred and the real offensives were launched on June 30.

At the opening of the Bregalnitza battle, the forces were thus disposed:—

- Bulgarian Army.** Commanded by Gen. Radko Dimitriev.<sup>3</sup>
- I. Army (Kutinchev) 9th Div.: one brigade each of 5th, 8th, (Vidin-Berkovitsa front). 14th Divs.; 13th Div.
  - V. Army (Petrov) 1st Div.; main body 5th Div.; main (Pirov-Vlasina front). body 14th Div., and one brigade 10th Div.
  - III. Army (Toshev) 12th Div., 15th Div., and main body 4th (Kyustendil) Div.
  - IV. Army (Korachev) Volunteer brigade; one brigade 4th (Kochana-Radovishta front) Div.; 7th Div., main body 8th Div.; one brigade 3rd Div.; main body 6th Div.; 2nd Div.
  - VI. Army (Ivanov) Main body 3rd Div.; a volunteer (Strumitsa-Seres front). brigade; 11th Div.; one brigade 10th Div., and one brigade 6th Div.

(The divisions 12 to 15 were new formations, much weaker than the divisions 1 to 9; the 10th and 11th Divs., created in Oct. 1912, were of intermediate strength.)

**Serbian Army.** Commanded by Putnikas, Chief of General Staff.

- II. Army (Stepanovich) Third Ban garrisons of Zayechar and (Danube to Vlasina). Knyashevats, Timok I., Shumaja II.
- I. Army (Crown Prince) Danube II., Danube I., Shumaja I. (from the old frontier to Car Vrh, astride the Egri Palanka road).
- III. Army (Yankovich) Drina II. (along the Zletovska and the lower Bregalnitza with detachments at Krivolak and Gevgeli).
- Morava II. Morava I., Timok II. Montenegro contingent, Cavalry division.

**Greek Army.** Commanded by Constantine (since March 18, King of the Hellenes).

- (Front: Gevgeli Left group 3rd and 10th Divs. Centre " 4th and 5th Divs. Right " 1st, 6th and 7th Divs. Reserve " 2nd Div.

(The 10th Div. was an improvised formation.) In addition, to deal with Albanian troubles, each of the allies retained considerable forces in the mountains; including the main body of the Montenegrin army.

Beginning on June 30, the Bulgarian II. Army drove the Greek front back all along the line till it lay S. of Gevgeli—N. of Langaza—W. of Struma mouth. The Bulgarian IV. Army broke in between the allies and captured Krivolak with its left, while its right, along with the III. Army, attacked the Serbians along the whole Bregalnitza-Zletovska line, which was forced. On the Egri Palanka front the Bulgarian IV. Army similarly drove in the Serbian I. Army's outposts.

But the Serbians, and also the Greeks, were disposed in considerable depth, and the Bulgarian soldier had little heart for the offensive once it became evident that the enemy was determined to fight. By the night of July 1 the offensive had died down, and it was the allies' turn to counter-attack. At this moment the Bulgarian-Serbian battle line ran approximately through Krivolak-Dragoyevo-Shtip line of the Bregalnitza and lower Zletovska-Raychani heights-Gorni Posadnik-Redki Buku-Car Vrh-heights E. of Egri Palanka-heights W. of and parallel to the frontier-headwaters of river Peinja. At the apex of the Serbian salient the Bulgarians had obtained a firm hold on Car Vrh.

Initiated on July 2, and developed on a large scale on the 3rd, the counter-attack of the Serbian III. Army broke through the Bulgarian line between the Zletovska and Redki Buku inclusive, hustling the defenders back on the 3rd and 4th to the upper Bregalnitza. Meant-

<sup>3</sup> Gen. Savov had resigned, not being in agreement with the war policy of the Government.

<sup>1</sup> For example, a British officer lecturing at the staff college on his return from Thrace told his hearers that the Bulgarian 7th Div. had remained in the Macedonian theatre to stiffen the Serbs—an extraordinary travesty of the facts.

time the Bulgarian forces between Shep and Krivolak were slowly driving back Timok II. to the Bregalnitsa, but it was now too late for this to influence either the main battle or that of the Greek front. On the latter, the Bulgarian advance had come to a standstill, as soon as King Constantine had brought up his reserves, and the



counter-offensive opened on the 3rd. His left (10th and 3rd Divs.) retook Gevgeli, his centre (4th, 2nd, 5th) Kiklisk; and his right (1st, 6th, 7th) drove back the Bulgarian left on Nigrita and also eastward on the Seres road (July 3-4). On July 7 the Greek right reached the Salónica-Drama railway, and their left from Gevgeli carried the pass over the Belashitsa which leads to Strumitsa. Thus Ivanov was cut off from the railway, and his only line of retreat lay up the narrow Struma valley to Jumaya.

Yielding to necessity, the Bulgarian forces on the Vardar withdrew, ere it was too late, into the Belashitsa valley, while those pursuing Timok II. on the lower Bregalnitsa halted and drew back. The opportunity which thus presented itself to the Serbian III. Army of interposing between Ivanov and Bulgaria led to a regrouping of the Serbian forces for the benefit of this army, which, pursuing its advantage, drove back its opponents towards the line of mountains in the upper Bregalnitsa bend (Obozna-1340-Grema).

But the Bulgarians, in order to relieve pressure and to keep their hold upon Western opinion, seized the initiative again while the regrouping was in process and the Greeks had hardly yet entered the Struma and Strumitsa valleys.

Their new offensive was twofold—local attacks by the II and V. Armies on all the routes leading into Old Serbia, and heavy counter-attacks on the front of the Serbian I. Army. The first, made with columns of varying strengths on the routes leading to Zajehar, Kynashevats, Pirov and Vlasina, was repulsed by the Serbian II. Army after some initial successes, and was over by July 10. The second was more serious, and it seems that the process of building up the strength of the Serbian III. Army opposite Kochana was not only suspended but actually reversed to cope with a crisis. Finally, however, the Bulgarians were repulsed here also, and retired to the line of frontier mountains (Golemi Vrh-Boderitsa-Rujan-Sivakobila), more or less in touch with the right of the forces in the mountains of the Bregalnitsa bend.

By this time the Greeks were in possession of the Strumitsa basin and had made some progress up the Struma. But Ivanov had obtained an opportunity that he could not have gained by his own efforts to extricate the various forces of the Bulgarian left which were scattered from the Vardar to the Struma.

The new allied offensive, therefore, began all along the Serbian line on the 15th, and starting on the battle-front above mentioned (Golemi Vrh-Sivakobila-Oboczna), resolved itself into a series of local combats with the object of cutting off as much as possible of Ivanov's rearguard detachments and of making strategic connexion with the Greek left at Pechchevo. At this stage, indeed, bold strategy was hardly required, for already Rumania had declared war on Bulgaria and had begun an unopposed march on Sofia, while the Turks at Chatalja and Bulair, ignoring the Treaty of London, reoccupied Adrianople without firing a shot.

Yet this relative inactivity of the Serbs gave the Bulgarians one more opportunity, which they seized. Using a manoeuvre which was destined to become a familiar practice of strategy in the World War, but, at that date and in that country of mountains and primitive communications, was conspicuously daring and novel, they transferred Kutinchev's I. Army from the old Serbian frontier (Vidin-Pirov front) to Ivanov's theatre, placing the newcomers on the outer flank of the advancing Greeks. On July 25 Ivanov and Kutinchev simultaneously attacked the leading troops of the Greek central or Struma column<sup>1</sup> before the main body was clear of the Kresna defile. But the capacity of resistance of the Greek troops, especially in mountain country for which their aptitude was remarkable throughout these campaigns, enabled them to weather the first crisis; they were reinforced from the left as well as from the rear, and on the night of the 26th-27th the Bulgarians withdrew towards the Jumaya Pass.

The venture was at an end. Surrounded by hostile columns converging on Sofia from every quarter, Bulgaria yielded on July 31, and on Aug. 10 was signed the Peace of Bucharest.

**BIBLIOGRAPHY.**—The outbreak of the World War in 1914 prevented all the combatants of the Balkan wars from producing official histories, and the only sources available are books and papers published immediately after the operations. Concise military accounts of the first war in all theatres are Bonchuelle's *Guerre Turco-balkanique* and Immanuel's *Balkankrieg*. For the Macedonian campaign and Scutari, by far the best authority is the French general staff publication *Résumé des armées étrangères* (monthly numbers Feb.-July 1914). For the campaign of 1912 in Thrace, A. de Pennerun's *Campagne de Thrace* is the best contemporary account; an interesting study by Maj. (afterwards Brig.-Gen.) P. Howell, *The Campaign in Thrace* (1913), stops short before Chatalja. In 1915 Gen. Palat produced a volume, *Guerre des Balkans*, which assembles most of the known evidence for the Thracian campaign. For the second war of 1913 very little of military value has been published. A summary of dispositions, movements, and events will be found in *Hazell's Annual*, 1914, pp. 369-71. For the Serbian part in both wars A. Kutschbach's *Die Serben im Balkankrieg* is useful as containing official information. (C. F. A.)

**BALL, SIR ROBERT STAWELL** (1840-1913), Irish astronomer, was born in Dublin July 1 1840. Educated at Trinity College, Dublin, he was appointed in 1865 assistant to the Earl of Rosse's observatory at Parsonstown, and whilst there he discovered four spiral nebulae. On the death of Lord Rosse two years later he became professor of mathematics in Dublin University and in 1874 Royal Astronomer of Ireland. This post he held until 1898; but in 1892 he was also made professor of astronomy and geometry at Cambridge and director of the university observatory. From 1897-9 he was president of the Royal Astronomical Society. He was knighted in 1886. He was an admirable lecturer and writer of popular books on his subject, as well as of more learned works such as his *Treatise on Spherical Astronomy* (1885) and *Treatise on the Theory of Seculars* (1900); and he was a congenial figure in all circles. He died at Cambridge Nov. 25 1913.

<sup>1</sup> The right, moving more or less independently, was at Dobri-nishte in the Mesta valley. The left had reached Pechchevo.



**BALL, THOMAS** (1819-1911), American sculptor (see 3.263), died at Montclair, N. J., Dec. 11 1911.

**BALLIN, ALBERT** (1857-1918), German merchant and one of the most eminent representatives of German commercial interests, was born Aug. 15 1857 at Hamburg. After having completed his mercantile training he organized the 'tween-deck (emigrant) traffic of the Carr Line. He next undertook the management of the passenger traffic of the Hamburg-Amerika Line and became in 1886 director and soon afterwards director-general of that enterprise, the expansion of which was essentially his work. The share capital of the Hamburg-Amerika Line was increased tenfold during his management. The network of its service was extended over the whole world, largely by the acquisition of a number of other lines. Ballin succeeded, by means of agreements with other German shipping companies, in developing German shipping on a grand scale; he was likewise the author of the German-American shipping agreement of 1902. He was regarded as enjoying the special confidence of the Emperor William II., who employed his services as an expert in all matters of shipping and commerce. Ballin died suddenly—heart-broken, it is said, by the military, political and commercial collapse of Germany—at Hamburg on Nov. 9 1918. (C. K.)

**BALLISTICS** (see 3.276).—I. INTERIOR BALLISTICS. Interior Ballistics has as its province the behaviour of a projectile, its propellant, and the gun from which it is being fired between the moment of firing and the moment at which the shell leaves the muzzle of the gun. From its nature it is a subject in which the synthesis of experimental results into general laws is a matter of great difficulty, and, in its present stage of development, striking differences of opinion still exist on fundamental points. A review of the work published after 1910 illustrates some of these differences.

In France the well-known system of Gen. P. Charbonnier, published in 1908, has been modified as well as elaborated by G. Sugot (*Mémoires de l'Artillerie navale*, 1913). Charbonnier, for French nitro-cellulose powder in long flat strips, assumes a rate of burning directly proportional to the pressure, and that the grains burn with a distinctly decreasing surface, while Gen. Gosset and R. Liouville (the exponents of the other leading French system) assume, for the same propellant, a rate of burning proportional to the pressure to the power of two-thirds, and a practically constant burning surface.

In Italy Madaschi's revision (published in 1914) of Bianchi's *Nozioni Fondamentali di Ballistica Interna* sets forth a very comprehensive system on different lines to that of Charbonnier, although it has some points in common such as the law of burning and the treatment of the resistance of the driving band.

In the U.S. official *Text Book of Ordnance and Gunnery* (1917) Ingalls' system of Interior Ballistics has been replaced by that of Tschappat, who again has adopted the same law of burning and treatment of band resistance as Charbonnier, but then diverges entirely from his methods.

Published in England we may note Sir George Hadcock's "Internal Ballistics" (*Proc. Royal Society*, A, vol. 94, London 1918), in which the treatment of the resistance of the band is extended to include a separate phase while the band is actually being engraved.

The existence of such important divergencies between published systems would in any event make it difficult to present the subject in brief and definite form. But there is also a further obstacle in the fact that the connexion between Interior Ballistics and the design of artillery materiel is so intimate that much of the resulting work is still considered by the naval and military authorities of most countries, if not of all, as to a great extent confidential.

On the other hand the experiences of the World War emphasized the importance of a due appreciation of the general principles of Interior Ballistics not only for purposes of design, but also for the intelligent and efficient employment of artillery materiel. To establish such an appreciation on a concrete basis, working formulae are a necessity, as without them

the magnitude of the effects cannot be studied, but the formulae should be comparatively simple, or from their cumbersome nature they will fail in their object. Formulae suitable for this purpose, although of a purely empirical nature, are available, and it is feasible to present and illustrate the leading principles with the aid of these simple formulae alone.

*Monomial Formulae for Velocity and Pressure.*—Interior Ballistics is concerned with the circumstances attending the motion of the shell in the bore of the gun. Considering these circumstances in a general way, when the charge is ignited, gas is evolved from the burning surface, and this gas exerts a gradually increasing pressure on the base of the shell. When a certain pressure has been developed, the shell starts to move and travels up the bore with continually increasing velocity until it leaves the muzzle of the gun with a certain muzzle velocity. During this travel up the bore the pressure at first increases comparatively rapidly until a certain pressure, the maximum pressure, is reached. The pressure then gradually decreases to the muzzle, the pressure when the shell leaves the muzzle being known as the muzzle pressure.

Modern propellants are for the most part colloids, and the grains composing the charge have some more or less definite geometrical shape. Typical velocity and pressure curves for such propellants will be found in the earlier article BALLISTICS (see 3.276-7). A charge made up in this way is in practice ignited in the chamber of the gun by means of a small additional charge of black powder, the igniter (which in turn has been ignited by the cap, primer, or tube), so that the whole of the surfaces of the grains are set alight or inflamed as nearly as possible simultaneously. For such colloid propellants the "Law of Burning by Parallel Layers" is well established. This law states that at any instant during the burning of the grain the thickness burnt through in the direction normal to the exposed surface is the same over the whole surface, or in other words, that the grain is diminished by an equal thickness in all directions.

The rate of burning of the propellant is a function of the pressure, and the greater the pressure, the quicker the grain will burn.

Consider now two charges of the same weight made up of (a) comparatively small and (b) comparatively large grains of the same geometrical shape.

For (a) the surface exposed when the charge is ignited (the "initial surface") will be greater than for (b), and the emission of gas will be greater to start with. The pressure and the rate of burning will increase comparatively rapidly, and the whole charge will be consumed sooner than in the case (b). In the case of (b) the total weight of gas emitted will be the same, but the mode of emission will be different. The initial surface is not so great, so that at the start the pressure will rise less rapidly and the combustion will be completed later. The maximum pressure will occur later and will be less than for (a), but will decrease more slowly.

Coming to the geometrical shape of the grain, the different forms employed may be divided into three main groups:

- (i.) Those which burn with a continually decreasing surface. To this group belong all solid grains and short cylinders with an axial perforation.
- (ii.) Those which burn with a practically constant surface, such as long thin tubes.
- (iii.) Those which burn with an increasing surface to a certain stage, the grain then breaking up into other forms quite different from the original shape. An example of this type is a cylindrical grain pierced longitudinally by a number of holes.

Cordite M.D.T. is an example of Group (ii.). The length of the tubes of circular section of which the charge is composed is so great compared with their thickness, that the burning of the ends may be neglected, and the surface of combustion is practically constant throughout the burning, as the tubes burn both inside and out.

The proportion of the whole thickness burnt through at any time is the same as the proportion of the weight or volume of the whole tube consumed. Cordite M.D., which is made up in long cords of circular section, is an example of Group (i.), and other forms frequently employed are long flat strips of rectangular section (such as the French B.N. powders), or square flat grains (such as ballistite). In all these forms the percentage of the thickness burnt through at any time of the burning is less than the percentage of the whole weight of the grain consumed.

The proportion of the whole thickness burnt through at any time is the same as the proportion of the weight or volume of the whole tube consumed. Cordite M.D., which is made up in long cords of circular section, is an example of Group (i.), and other forms frequently employed are long flat strips of rectangular section (such as the French B.N. powders), or square flat grains (such as ballistite). In all these forms the percentage of the thickness burnt through at any time of the burning is less than the percentage of the whole weight of the grain consumed.

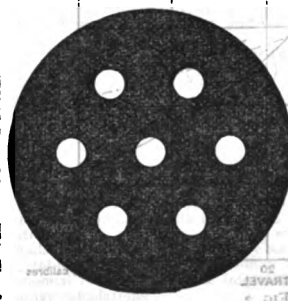

FIG. I.

\* These figures indicate the volume and page number of the previous article.



The multiperforated grains in which American nitrocellulose of the larger sizes is made up, are an example of (iii.). The cylindrical grain has seven equal longitudinal perforations; a typical cross section is shown in fig. 1.

One of the perforations coincides with the axis of the cylinder, and the others are disposed symmetrically about the axis, their centres forming a regular hexagon and being so arranged that the least dimension of the grain or "web thickness," which is the least distance between any two adjacent circumferences, is the same throughout.

During the first phase of the combustion, i.e. before the grain breaks up, the grain burns with an increasing surface, the thickness burnt through at any time being greater than the percentage of the whole weight of the grain consumed. When the web thickness is burnt through, the grain breaks up into twelve slender triangular prisms with curved sides known as "slivers." The slivers will burn with a decreasing surface in a very similar manner to long cords.

The less the percentage of the whole weight of the grain consumed compared with the percentage of the thickness burnt through, the more "progressive" is the shape said to be. Fig. 2 illustrates the burning of different forms of grain in a gun.

It shows the pressure-space curves for a charge of the same weight made up of long cords, long tubes, and multiperforated grains; the diameter of the cord, thickness of the tube, and web thickness of the m.p. grain are so arranged that the whole charge is just completely consumed at the muzzle, i.e. after the same travel of the shell; the same shell is supposed to be fired from the same gun with these three different natures of charge.

The muzzle velocity will be the same in each case, but the pressure curves very different. For the charge to be completely consumed at the muzzle the diameter of the cord and thickness of tube will be the same, but the web thickness of the m.p. grain will be considerably less, as after this is burnt through there are still the slivers to burn.

The maximum pressure is lower and the muzzle pressure higher with the tube than with the cord or m.p. grain, which are about level in this respect, but the point of maximum pressure with the m.p. grain occurs farther up the bore than with the cord, the point of maximum pressure with the tube being between the two.

The point where the web thickness of the m.p. grain is burnt through and the grain breaks up into slivers, is shown on the diagram. From this point the pressure drops rapidly, owing to the change from an increasing to a decreasing surface of combustion, until it runs into the curve for the cord which it follows to the muzzle.

If we increase the diameter of the cord and the web thickness of the m.p. grain (keeping the weight of the charge the same) the maximum pressure will be lower, but the muzzle velocity will also be lower as the charge will not be consumed in the gun.

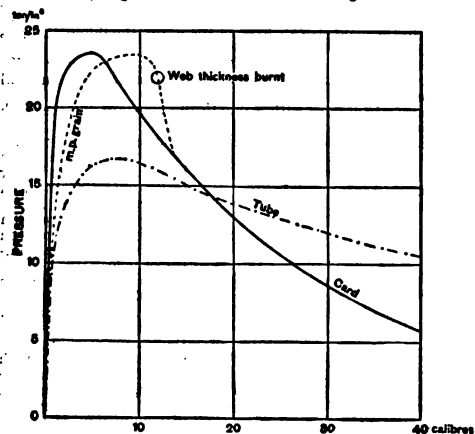

FIG. 2.

In practice the maximum pressure is generally the limiting factor as we must not exceed the safe working pressure of the gun, and the endeavour is to get the required muzzle velocity combined with good regularity; for this it is desirable that the muzzle pressure should be low and the charge completely burnt well back in the gun.

The best practicable combination of form and weight of charge for this purpose is the problem of the designer.

This is only for illustrative purposes. In practice the charge should be completely consumed before the shell reaches the muzzle.

The main problem of Interior Ballistics may now be stated as follows: Given the necessary particulars of the gun, charge, and shell, to determine the corresponding values of the velocity of the shell (with special attention to the muzzle velocity), the pressure of the gases of the charge (with special attention to the maximum pressure), and the proportion of the charge burnt (with special attention to the point of complete combustion), at any point of the travel of the shell up the bore.

Various subsidiary problems of an inverse nature required for considering questions of design and analysing firing results will also suggest themselves.

The physical phenomena, as will be readily understood, are of a very complex nature. Besides the energy expended in propelling the shell from the muzzle with a certain muzzle velocity, we have the work expended on the charge, on the gun and mounting (recoil) and in giving rotation to the shell; work is also done in forcing the driving band into the rifling grooves ("engraving" the band), and in overcoming friction up the bore. There is also the heat lost by conduction.

As regards the gun, besides the main dimensions ("calibre," "chamber capacity," and "shot travel"), variations in the design of the rifling and the state of wear of the bore generally may have an appreciable effect on the results. This does not exhaust the possible causes of variation, and in fact two guns of the same design even when new may not give the same muzzle velocity under conditions which have carefully been made as nearly identical as possible.

As regards the charge, in addition to the nature of the propellant and form of grain, we may have to take into account the circumstances of the ignition and the temperature of the charge as fired. Two samples or "lots" of the same propellant, however carefully made to be as nearly identical as possible, may give different ballistics in the same gun, and even if they give practically the same results when new, the matter may be complicated later by the length and conditions of storage.

As regards the shell, besides the weight, the design of the driving band may have to be taken into account, as this may affect its resistance.

It must be understood that though all these causes and others not touched on may appreciably affect the results, they by no means all do so in all circumstances, from the point of view of their practical effect on shooting; indeed, some of them may require very refined experimental methods even to detect them. For this reason a due appreciation of their relative importance in any particular case is very desirable and can be obtained only by close study and wide experience.

From the extreme complexity of the physical phenomena, even under carefully standardized conditions, it may be doubted if a complete solution of the problem is possible, but various systems more or less complete for an approximate solution have been proposed and worked out. Some of these are referred to above. The underlying theory is of necessity difficult and the calculations involved laborious, the complications increasing rapidly with the degree of comprehensiveness attempted.

None of these systems up to date can be said to have gained general acceptance, and in fact serious divergencies on the most crucial points will be found in the different authorities. All that will be attempted here will be a short description of certain empirical formulæ which have been and still are considerably used for practical calculations of muzzle velocity and maximum pressure. They are of the monomial type, and by their aid, given the muzzle velocity and maximum pressure known to be obtained with certain combinations of gun, charge and shell, we can endeavour to predict the changes in ballistics which will result from variations in the data which give the known results.

The following notation will be employed:

$d$  = calibre in inches.

The calibre is defined as the diameter of the bore of the gun measured across the lands (the portions of the bore between the grooves of the rifling).

$G$  = chamber capacity in cubic inches.

That is the volume of the portion of the interior of the gun which is behind the shell when rammed home. In the case of guns which use a metallic cartridge case allowance must be made for the space occupied by this.

$S$  = shot travel in inches.

That is the distance moved through by the projectile from the time it starts to move till it leaves the muzzle.

$W$  = weight of shell in lb.

$M$  = weight of charge in lb.

$L$  = least dimension of the grain in inches.

That is the diameter of the cords, the thickness of the tubes or strips, or the web thickness of the m.p. grains of which the charge is made up.

$V$  = muzzle velocity in feet per second ( $f/s$ ).

$P$  = maximum pressure in tons per square inch ( $\text{ton}/\text{in}^2$ ).

In order to facilitate calculations and comparisons of results with guns of different calibres it is advantageous to introduce the principle of "similar guns," and to reduce all particulars to those corresponding to a standard or unit gun of 1 in. calibre. The reduction of the data to those of the standard gun, in any particular case, is effected

by supposing the gun under consideration, together with its shell and charge, to be expanded or contracted symmetrically until its calibre is equal to 1 inch. Corresponding to G, W, S, M, and L, for the gun calibre  $d$  in. we shall have for the standard gun

$$G_1 = \frac{G}{d^3}, S_1 = \frac{S}{d}, M_1 = \frac{M}{d^3}, W_1 = \frac{W}{d^3}, L_1 = \frac{L}{d}$$

V and P will remain unchanged.

The working formulae for muzzle velocity and maximum pressure will be based on the assumption that they can be put in the form—

$$(1) \quad V = K, G_1^s S_1^t W_1^m M_1^l L_1^i$$

$$(2) \quad P = K_p G_1^s W_1^m M_1^l L_1^i$$

Where  $g, s, w, m,$  and  $l$  are empirical indices, positive or negative integral or fractional, and  $K, K_p$  empirical constants. The values of the indices denoted by the same letter are different in (1) and (2).

These formulae are to be regarded as purely empirical, but with a due appreciation of their possibilities and limitations they will be found very useful working tools.

Assuming as the result of experience, suitable values for the indices, we can from known firing results (muzzle velocity and maximum pressure) for a certain gun, charge, and shell evaluate  $K$ , and  $K_p$  of (1) and (2) by simple calculation with a table of logarithms. Then by a reverse process, using the values of  $K$ , and  $K_p$ , so obtained, we can calculate the muzzle velocity and maximum pressure to be expected with another gun, shell, and charge (of the same propellant made up of grains of the same form), inserting the appropriate values of  $G, S, W, M,$  and  $L$ , in (1) and (2).

The following tables have been drawn up as a guide to values of the indices which will be found suitable for guns, at any rate for trial purposes, with the following propellants:—

- Long cords of Cordite M.D. (M.D.).
- Long tubes of Cordite M.D.T. (M.D.T.).
- Short tubes or m.p. grains of nitrocellulose (N.C.T.).

TABLE I.  
Indices for Muzzle Velocity.

$g.$	$s.$	$w.$	$m.$	$l.$
-0.25	+0.2	-0.4	M.D.T. +0.7 N.C.T. } +0.6 M.D. }	M.D.T. } -0.3 N.C.T. } M.D. }

TABLE II.  
Indices for Maximum Pressure.

$g.$	$w.$	$m.$	$l.$
M.D.T. -1.00		M.D.T. +1.8	M.D.T. } -1.40 N.C.T. }
N.C.T. -1.10	+0.6	N.C.T. } +1.6 M.D. }	M.D. -0.85
M.D. -1.15			

An example to illustrate the uses of these tables will now be given:—

A 6-in. gun, chamber capacity 1600 in., shot travel 350 in., fires a 100-lb. shell with a charge of 25 lb. of M.D., diam. of cord 0.2 in., gives a muzzle velocity of 2650 f/s with maximum pressure of 16 ton/in<sup>2</sup>. What muzzle velocity and maximum pressure may be expected from a 5-in. gun, chamber capacity 600 in., shot travel 140 in. with a 55-lb. proj. shell and a charge of 10 lb. M.D., diam. of cord 0.12 inches?

For the 6-in. gun we have:—

$$\begin{array}{ll} G = 1600 & G_1 = 74 \\ S = 250 & S_1 = 41.6 \\ W = 100 & W_1 = 0.463 \\ M = 25 & M_1 = 0.156 \\ L = 0.2 & L_1 = 0.033 \\ V = 2650 & \\ P = 16 & \end{array}$$

From (1) and Table I.—

$$V = K, G_1^{-0.25} S_1^{+0.2} W_1^{-0.4} M_1^{+0.7} L_1^{-0.3}$$

Taking logarithms and rearranging,

$$\log. K_p = \log. V + 0.25 \log. G_1 + 0.6 \log. 1/M_1 - 0.2 \log. S_1 - 0.4 \log. 1/W_1 - 0.15 \log. 1/L_1$$

whence

$$\log. K_p = 3.524$$

Similarly from (2) and Table II.—

$$P = K_p G_1^{-1.15} W_1^{+0.6} M_1^{+1.6} L_1^{-0.85}$$

whence

$$\log. K_p = 2.645$$

Then for the 5-in. gun:—

$$\begin{array}{ll} G = 600 & G_1 = 4.8 \\ S = 140 & S_1 = 28 \\ W = 55 & W_1 = 0.44 \\ M = 10 & M_1 = 0.08 \\ L = 0.12 & L_1 = 0.024. \end{array}$$

and

$$\log. V = \log. K_p + 0.2 \log. S_1 + 0.4 \log. S_1 + 0.15 \log. 1/L_1 - 0.25 \log. G_1 - 0.6 \log. 1/M_1$$

which, using the value of  $\log. K_p$  found for the 6-in. gun, gives

$$V = 2350 \text{ f/s.}$$

Similarly using the value of  $\log. K_p$  found for the 6-in. gun we get for the 5-in. gun

$$P = 18.6 \text{ ton/in}^2.$$

It must not be inferred from this that for any propellant we can arrive at values of  $K$ , and  $K_p$ , and the indices  $g, s, w, m, l$ , which will reproduce the firing results in all circumstances. Investigations to determine such fixed values once for all, will soon lead to disappointment. It must be remembered that we have only embodied in the formulae differences in weight, calibre, chamber capacity, shot travel, weight of shell, weight of charge, and dimensions of the propellant. We have not taken into account any of the other causes of variation touched on above.

When we analyze firing results by means of (1) and (2) all these neglected factors are as it were embodied in the values of  $K$ , and  $K_p$ , arrived at, and these values of  $K$ , and  $K_p$ , and also the values of the indices are only suitable for application in other cases in which the effects of the neglected factors are proportionally similar.

The "density of loading,"<sup>1</sup> and the position of the point of complete combustion of the charge will also have an influence, and an adjustment of constants and indices may be necessary for widely different densities of loading, and according as to whether the charge is completely consumed well back in the gun, or whether there is a proportion of the charge still unburnt when the shell leaves the muzzle.

The values of the indices in Tables I. and II. are adjusted for the average conditions of modern practice,<sup>2</sup> and if the above warning is kept in mind and the formulae used in an intelligent manner they will, as already stated, be found extremely useful working tools.

If only a few of the data vary it is not necessary to work with the complete formulae (1) and (2). Thus if we are dealing with the same gun and shell and the same propellant of the same form and size, and only wish to investigate the effect on the muzzle velocity of differences in weight of the charge, we need not introduce the standard gun and work out the constant  $K_p$ , but may write

$$\frac{V'}{V''} = \left( \frac{M'}{M''} \right)^w$$

where the muzzle velocity  $V'$  is known for a charge of weight  $M'$ , and we want to find the velocity  $V''$  for a charge  $M''$ . Again if we are dealing with differences in weight of both charge and shell we may employ

$$\frac{V'}{V''} = \left( \frac{M'}{M''} \right)^m \left( \frac{W'}{W''} \right)^w$$

As an example—a gun gives m.v. 2500 f/s with full charge 12 lb. M.D.T., what will the m.v. be with a 3/4 charge of 9 lb.?

Here  $V' = 2500$  for  $M' = 12$ , and we have to find  $V''$  for  $M'' = 9$  from

$$\frac{V'}{V''} = \left( \frac{M'}{M''} \right)^{0.7}$$

we have

$$\frac{V'}{V''} = \left( \frac{12}{9} \right)^{0.7} = (1.33)^{0.7} = 1.22.$$

Therefore

$$V'' = \frac{2500}{1.22} = 2050 \text{ f/s.}$$

When the variations in the data are comparatively small the monomial formulae may be replaced by a simple percentage approximation which will give sufficient accuracy while reducing the calculations to little more than easy mental arithmetic. The following tables derived from the indices already employed with the monomial formulae give the information necessary for such percentage calculations.

<sup>1</sup> The density of loading is defined as the "ratio of the weight of the charge to the weight of a volume of water just sufficient to fill the chamber." This is given by 27.7 M/G. The greater the density of loading, the less the "initial air space" (the volume of the chamber not actually occupied by the grains of the charge).

<sup>2</sup> These indices are suitable for ordnance. For rifles they require considerable modification, see Hardcastle "Monomial Formulas for Pressure and Velocity for Ordnance and Small Arms," *Royal Artillery Journal*, vol. xiii.

TABLE III.

Percentage alteration in muzzle velocity due to an alteration of +10% in—

Chamber Capacity.	Shot Travel.	Weight of Shell.	Weight of Charge.	Least Dimension of Grain.
-2.5%	+2%	-4%	M.D.T.+7% N.C.T.+6% M.D.+6%	M.D.T.-3% N.C.T.-2% M.D.-1.5%

TABLE IV.

Percentage alteration in maximum pressure due to an alteration of +10% in—

Chamber Capacity.	Weight of Shell.	Weight of Charge.	Least Dimension of Grain.
M.D.T.-10% N.C.T.-11.5% M.D.-11.5%	+6%	M.D.T.+18% N.C.T.+16% M.D.+16%	M.D.T.-14% N.C.T.-14% M.D.-8.5%

Example. A gun gives m.v. 1680 f/s for max. press. 15.5 ton/in<sup>2</sup> with a charge of 20 lb. N.C.T. What decrease in charge will give a velocity of 1660 f/s, and what will be the corresponding pressure?

A change from 1680 to 1660 f/s is a decrease of 1.19%. From Table III. a decrease of 10% in weight of charge will decrease m.v. 6%. Therefore a decrease of 1.19% will correspond to a decrease

in weight of charge of  $\frac{10 \times 1.19}{6} = 1.98\% \text{ or } 0.396 \text{ lb.}$

From Table IV. 10% decrease in charge decreases P by 16%. Therefore 1.98% decrease in charge decreases P by 3.16% = 0.49 ton/in<sup>2</sup>. Hence the maximum pressure for V = 1660 f/s will be about 15 ton/in<sup>2</sup>.

For the experimental determination of any of the indices, say the velocity index m, we require a series of firing results in which the corresponding quantity M has alone been varied, and the muzzle velocities recorded.

The logarithms of the corresponding values of V and M are then plotted as ordinates and abscissae and a straight line fitted to the points as closely as possible. The slope of this line, as measured by the tangent of the angle which it makes with the axis of M, gives the value of the index.

As an example fig. 3 shows the plotting by this method of a number of firing results for a certain gun with different weights of charge, all the other particulars being kept the same.

The firing results plotted were:

M. lb.	6.12	6.62	7.69	8.0	9.0	10.25	11.0
V f/s	816	865	959	991	1071	1164	1222

The points obtained are shown by small circles.

It is then evident that a straight line as shown on the diagram can be drawn which will pass very nearly through all the points.

The best straight line could be determined mathematically by the "method of least squares," but in practice all that is necessary is to take a piece of thin black thread and move it about on the diagram estimating the best position by eye. Drawing the best straight line determined in this simple manner we can read off the index m. In the present case we thus arrive at the result that m = 0.7, so that

$$\frac{V'}{V} = \left(\frac{M'}{M}\right)^{0.7}$$

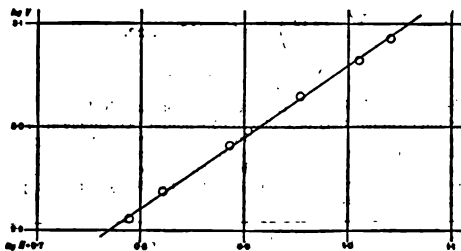

FIG. 3.

Connexion between Interior and Exterior Ballistics.—When the shell leaves the muzzle of the gun and starts to describe its trajectory it enters the domain of Exterior Ballistics, but the condition in which it leaves the muzzle, particularly as regards initial velocity and steadiness and the round-to-round variations

in these conditions, will have an important influence on the behaviour of the individual rounds, and on the dispersion of a group of rounds fired from the same gun at the same elevation. These initial conditions are determined by what happens as the shell travels up the bore and at the moment it leaves it, and it is therefore appropriate to touch on them here.

Thus, if the shell leaves with a large initial "yaw" (inclination of the longer axis to the direction of motion of the centre of gravity), the range will in general be less than that which would be obtained if the initial yaw were small. Again, from the point of view of dispersion, even although all the shell were equally steady, the greater the round-to-round variation in the muzzle velocity, the greater would be the dispersion in range.

From the point of view of accuracy, as measured by the small dispersion of a group of rounds fired at the same elevation, the round-to-round variation in the initial conditions should be as small as possible. As far as regularity in muzzle velocity is concerned, the charge is a main factor, but the driving band and the state of the bore also have an effect.

Considering the charge, the constituents of this should be, in the first place, as homogeneous as possible, both as regards composition and dimensions. Further, for the same shape of grain the longer the travel of the shell before the charge is completely consumed, the more sensitive is the muzzle velocity to variations in size, etc., so that the further back the charge can be burnt the better, or the smaller the size that can be used the better. This is of course limited by the muzzle velocity required; the smaller the size the less muzzle velocity can be obtained for the same maximum pressure.

When we come to consider the degree of steadiness with which the shell leaves the muzzle and the variations in this, while there is no question as to its importance, the conditions which govern it and their relative importance are by no means well established.

The shell has to be given rotation, by means of the rifling grooves, in order to maintain an end-on position in its subsequent flight, and, in the first place, it is clear that it must be satisfactorily centred when rammed home, and that the design of the rifling grooves and driving band must be mechanically suitable for imparting the rotation in an efficient manner. Further we have as possible influences on the conditions of emergence, the effect of the blast of the gases as they are released at the muzzle, and the effect on the shell of the vibrations of the barrel. As to the former the violence of the blast effect will depend on the muzzle pressure, and the general practice is to keep this as low as possible so as to decrease the chances of trouble from this cause. As to barrel vibrations, although some experimental work has been done in the case of rifles, there is very little really known as to the behaviour of ordnance in this respect, and their influence on the state of departure of the shell. It is a matter which undoubtedly calls for research, but the experimental and theoretical investigation bristles with formidable difficulties.

Bibliography.—A list of some recent works and papers on the subject is appended. It is not intended to be complete, but covers a good deal of ground, and may be useful in suggesting a course of reading which might be undertaken by anyone intending to study the subject seriously. G. Bianchi, *Nozioni Fondamentali di Balistica Interna* (1914, 2nd. ed., revised by G. Madaschi); P. Charbonnier, *Balistique Intérieure* (1908); Desmazières, "Note sur l'état actuel de la balistique intérieure," *Revue d'Artillerie*, vol. 85, April and May-June 1920; Gosset and R. Liouville, *Les Effets des Explosifs* (1919); A. G. Hadcock, "Internal Ballistics," *Proceedings of the Royal Society, A*, vol. 94, London, 1918; G. Sugot, "Les Formules de Charbonnier," *Mémoires de l'Artillerie Navale* (1913); W. H. Tschappat, *Text Book of Ordnance and Gunnery* (1917).

(R. K. H.)

II. EXTERIOR BALLISTICS. Previously to the World War, and under the practice in vogue in 1910, guns proper were used only in direct fire at elevations below 20 degrees. Fire from guns, howitzers or mortars, above 15° elevation was known as high angle fire, and fire from howitzers at angles of elevation below 15° was known as curved fire. Howitzers were fired at elevations up to 45°; mortars were used at angles of elevation up to 65°; but howitzers and mortars had low muzzle velocities, relatively short ranges, and the maximum ordinates of their trajectories were comparatively small.

From 1915, however, the nature of the fighting on the western front called for the development of extreme ranges in all artillery, and the easiest and quickest method of increasing the range of a given gun was to modify or redesign its mount so as to permit the piece to be fired at the angle of elevation that would produce the maximum, or at any rate the necessary, range. The method was adopted by all the armies for all calibres of land guns. Furthermore, anti-aircraft guns were designed to permit of all angles of elevation up to 90 degrees. Thus for the first time it became necessary to have a knowledge of all the elements along the trajectory and not merely of the range, time of flight, etc., of the horizontal trajectory. Soon after the war started, improvements in projectiles, which had been developing slowly since 1900, began to make themselves felt in still further increasing ranges.

**Causes which led to New Methods.**—Siacci's method involves an assumption (see 3.274, Equation 59), which introduces an error, if an attempt is made to complete the whole trajectory in a single arc, when the angle of departure is more than 20 degrees. The method of "successive arcs," based on Siacci (see 3.275), has been used extensively and has the required accuracy, providing the arcs taken are short, but the method is laborious and has other disadvantages arising from the discontinuity of the successive arcs. To overcome these difficulties and at the same time simplify calculations on trajectories, England and France and later the United States adopted the method of numerical integration of the differential equations of motion of the projectile as the standard method of solution. In all these countries the best mathematical talent was brought to bear on the solution of this problem, which in peace-time had received the attention only of a limited number of officers and others connected with the military and naval services and of a few civilians.

The outline of the method of numerical integration given below is that first proposed by F. R. Moulton in the United States, and developed to a high degree by the mathematicians and others associated with him in the study of ballistic problems during the World War. Other methods worked out in England and France, while possessing the same advantages over the older methods, are perhaps not so simple in their application.

**Preliminary Assumptions.**—For purposes of small arc computations, the retardation of the projectile with normal air density at the gun is represented by

$$(1) \quad R = vG(v)H(y)$$

where  $R$  is the retardation of the projectile,  $v$ , the velocity in metres in the direction of its motion.

$G(v)$ , a function of  $v$ , experimentally determined; the retardation due to air resistance of a projectile of ballistic coefficient = 1, moving horizontally at the height of the muzzle of the gun in air at a temperature of 15° C. and a pressure of 760 mm., 78% saturated with water.

$H(y)$ , a function of the altitude  $y$  (above the muzzle of the gun); the ratio between the density of the air at that altitude and its density at a zero altitude.  
 $C$ , the ballistic coefficient.

**Law of Air Resistance.**—The results obtained from any mathematical analysis of the motion of a projectile depend for their accuracy upon the care with which the law of air resistance has been experimentally determined. (For a description of the method and calculations by which Bashforth's ballistic tables, including the law of air resistance, were determined, see 3.271, 272.) In later experiments the same essential methods were followed with the use of more accurate instruments and with projectiles more nearly of the modern form. Such are the Krupp experiments (see 3.273), and the Gavre Commission experiments made in 1888. Chief Engineer Garnier has smoothed out the irregularities in the results of the Gavre Commission firings and has thus obtained a law of air resistance which, while not differing essentially in any region from the results of experiments, is of a continuous character. This cannot be said of Zabudski's law based upon various powers of the velocity.

**The G Function.**—The retardation of the standard projectile due to standard air resistance is put in the form  $vG(v)$  for convenience in numerical integration. The function  $G(v)$  here represents the ratio

between the retardation and the velocity at each instant.  $G(v)$  as smoothed out by Chief Engineer Garnier is tabulated with  $\frac{v^2}{100}$  as an argument, velocities and retardations being expressed in his tabulated form in metres.

On the next page (p. 388), Table I. gives an abridged table of the  $G$  Function ( $G$  is the retardation divided by the velocity, for  $C=1$  and at surface air density), based on the French tables, giving  $10 \log G$  with the argument  $\frac{v^2}{100}$ ;  $v$  expressed in metres per second.

**The B Function.**—The retardation function is sometimes written  $v^2 B(v)$ , and then  $B(v)$  is the ratio between the retardation and the square of the velocity. In those regions and under those conditions where the "square law" of resistance holds true,  $B(v)$  is a constant. Figure 1 shows Mayevski's and Zabudski's values for  $B(v)$  or  $\frac{G(v)}{v}$  as compared with Garnier's smoothed-out Gavre Commission values. The tremendous change in the law in the neighbourhood of the velocity of sound is to be noted. More recent but uncompleted

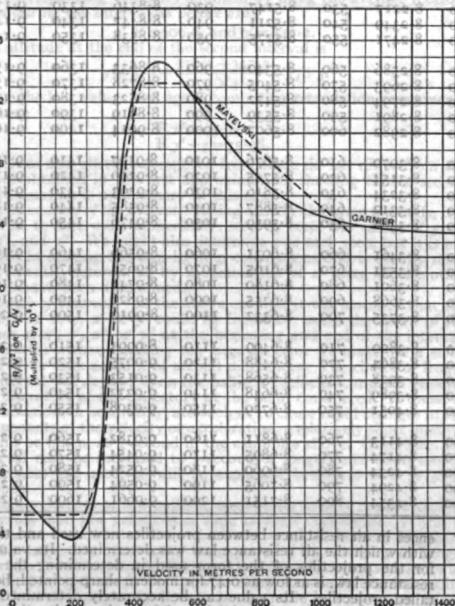

FIG. 1.

experiments indicate that the disturbance in the vicinity of the velocity of sound may be changed in amount and displaced in position by changes in the form of the projectile.

**Density Function.**—The air density function  $H(y)$  is intended to represent the normal change in density of the air with height. The value of the density function here assumed is,

$$(2) \quad H(y) = 10^{-0.00019y}$$

where  $y$  is in metres. The coefficient of  $y$  is subject to seasonal variations. (See *Cours de Ballistique*—G. Sugot, 1918.)

The density function merely expresses the law of change of density with altitude. It is quite possible to calculate trajectories in air that do not follow this or any other continuous law, providing we know the density at each height. It is necessary, however, in the calculation of ballistic tables to follow some definite law in order to make the tables consistent throughout. Seasonal variations and other variations from the assumed law are taken care of in differential corrections as will be explained below.

**The Ballistic Coefficient.**—The ballistic coefficient is represented by the formula,

$$(3) \quad C = \frac{w}{i d^2} \text{ where}$$

$w$  is the weight of the projectile in pounds.

$d$ , the diameter of the projectile in inches.

$i$ , a factor called the coefficient of form which accounts for differ-

TABLE I.

$v^2$ 100	log. G.	$v^2$ 100	log. G.	$v^2$ 100	log. G.	$v^2$ 100	log. G.	$v^2$ 100	log. G.	$v^2$ 100	log. G.	$v^2$ 100	log. G.	$v^2$ 100	log. G.
0	.....	400	8-4354	800	8-7151	1200	9-0661	1600	9-2282	2000	9-2974	6000	9-4655	8000	9-5043
10	7-7244	410	8-4415	810	8-7238	1210	9-0727	1610	9-2306	2100	9-3093	6100	9-4676	11000	9-5568
20	7-8655	420	8-4474	820	8-7328	1220	9-0791	1620	9-2329	2200	9-3199	6200	9-4696	12000	9-5731
30	7-9462	430	8-4534	830	8-7416	1230	9-0852	1630	9-2351	2300	9-3295	6300	9-4716	13000	9-5888
40	8-0025	440	8-4594	840	8-7506	1240	9-0912	1640	9-2373	2400	9-3381	6400	9-4736	14000	9-6034
50	8-0453	450	8-4654	850	8-7597	1250	9-0972	1650	9-2395	2500	9-3459	6500	9-4756	15000	9-6174
60	8-0800	460	8-4716	860	8-7688	1260	9-1028	1660	9-2417	2600	9-3531	6600	9-4776	16000	9-6304
70	8-1089	470	8-4776	870	8-7781	1270	9-1083	1670	9-2438	2700	9-3598	6700	9-4796	17000	9-6429
80	8-1336	480	8-4836	880	8-7873	1280	9-1137	1680	9-2459	2800	9-3659	6800	9-4815	18000	9-6549
90	8-1552	490	8-4899	890	8-7967	1290	9-1189	1690	9-2479	2900	9-3715	6900	9-4835	19000	9-6662
100	8-1745	500	8-4959	900	8-8061	1300	9-1240	1700	9-2499	3000	9-3769	7000	9-4854	20000	9-6769
110	8-1917	510	8-5021	910	8-8155	1310	9-1289	1710	9-2519	3100	9-3819	7100	9-4874	21000	9-6873
120	8-2074	520	8-5084	920	8-8251	1320	9-1337	1720	9-2539	3200	9-3865	7200	9-4893	22000	9-6973
130	8-2217	530	8-5147	930	8-8346	1330	9-1384	1730	9-2558	3300	9-3910	7300	9-4912	23000	9-7068
140	8-2349	540	8-5211	940	8-8442	1340	9-1430	1740	9-2576	3400	9-3951	7400	9-4931	24000	9-7159
150	8-2471	550	8-5275	950	8-8538	1350	9-1474	1750	9-2595	3500	9-3991	7500	9-4950	25000	9-7246
160	8-2586	560	8-5340	960	8-8633	1360	9-1517	1760	9-2613	3600	9-4029	7600	9-4969	26000	9-7331
170	8-2693	570	8-5405	970	8-8728	1370	9-1559	1770	9-2631	3700	9-4065	7700	9-4988	27000	9-7412
180	8-2794	580	8-5472	980	8-8823	1380	9-1599	1780	9-2648	3800	9-4100	7800	9-5006	28000	9-7490
190	8-2891	590	8-5539	990	8-8919	1390	9-1639	1790	9-2665	3900	9-4133	7900	9-5025	29000	9-7566
200	8-2982	600	8-5607	1000	8-9014	1400	9-1678	1800	9-2682	4000	9-4165	8000	9-5043	30000	9-7639
210	8-3070	610	8-5676	1010	8-9107	1410	9-1715	1810	9-2699	4100	9-4196			31000	9-7710
220	8-3154	620	8-5745	1020	8-9200	1420	9-1752	1820	9-2715	4200	9-4226			32000	9-7779
230	8-3234	630	8-5816	1030	8-9293	1430	9-1788	1830	9-2731	4300	9-4254				
240	8-3312	640	8-5887	1040	8-9385	1440	9-1822	1840	9-2747	4400	9-4282				
250	8-3388	650	8-5959	1050	8-9476	1450	9-1857	1850	9-2763	4500	9-4309				
260	8-3461	660	8-6031	1060	8-9566	1460	9-1890	1860	9-2779	4600	9-4335				
270	8-3531	670	8-6105	1070	8-9654	1470	9-1922	1870	9-2794	4700	9-4360				
280	8-3601	680	8-6180	1080	8-9741	1480	9-1953	1880	9-2809	4800	9-4385				
290	8-3668	690	8-6255	1090	8-9826	1490	9-1984	1890	9-2824	4900	9-4410				
300	8-3735	700	8-6332	1100	8-9910	1500	9-2014	1900	9-2838	5000	9-4434				
310	8-3800	710	8-6409	1110	8-9994	1510	9-2044	1910	9-2853	5100	9-4458				
320	8-3864	720	8-6488	1120	9-0075	1520	9-2072	1920	9-2867	5200	9-4481				
330	8-3928	730	8-6568	1130	9-0153	1530	9-2100	1930	9-2881	5300	9-4504				
340	8-3989	740	8-6648	1140	9-0232	1540	9-2128	1940	9-2895	5400	9-4526				
350	8-4051	750	8-6729	1150	9-0308	1550	9-2155	1950	9-2909	5500	9-4548				
360	8-4113	760	8-6811	1160	9-0382	1560	9-2182	1960	9-2922	5600	9-4570				
370	8-4174	770	8-6895	1170	9-0454	1570	9-2207	1970	9-2935	5700	9-4592				
380	8-4234	780	8-6960	1180	9-0524	1580	9-2232	1980	9-2948	5800	9-4613				
390	8-4294	790	8-7065	1190	9-0594	1590	9-2257	1990	9-2961	5900	9-4634				
400	8-4354	800	8-7151	1200	9-0661	1600	9-2282	2000	9-2974	6000	9-4655				

ences in air resistance between projectiles now used and those with which the air resistance law was determined. Its value,  $\Gamma$  for the projectiles of the form used in determining the air-resistance law, is as low as 0.47 for modern sharp-pointed, boat-tailed projectiles. Its value can be accurately determined for any projectile by working backward from the results of firing. Such determinations show that the value may and usually does vary for the same projectile if fired at different ranges.

The Differential Equations of Motion of the Projectile.—Neglecting the convergence of the action lines of gravity due to the spheroidal form of the earth and also the slight diminution in the intensity of the force of gravity due to the height which modern projectiles reach, we may write the differential equations of motion of the projectile considered as a material point, as follows:—

$$(4) \quad \frac{d^2x}{dt^2} = -R \cos \theta = -x'$$

$$(5) \quad \frac{d^2y}{dt^2} = -R \sin \theta - g = y''$$

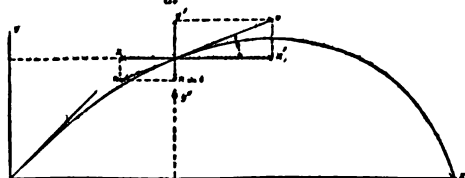

FIG. 2.

where, (see fig. 2),  $x$  is the abscissa of any point of the trajectory, positive to the right,

$x'$ , the horizontal component of the velocity at that point,  
 $x''$ , the horizontal component of the acceleration,  
 $y$ , the ordinate corresponding to  $x$ , positive up,  
 $y'$ , the vertical component of the velocity at that point,  
 $y''$ , the vertical component of the acceleration,  
 $\theta$ , the angle that the tangent to the trajectory makes with the horizontal.

Since  $v$  is the velocity of the projectile in the direction of its motion,

$$(6) \quad \cos \theta = \frac{x'}{v}$$

$$(7) \quad \sin \theta = \frac{y'}{v}$$

and if we assume

$$(8) \quad E = \frac{R}{v}$$

as the ratio between retardation and velocity, we

may write (4) and (5) as follows:

$$(9) \quad x'' = -E x'$$

$$(10) \quad y'' = -E y' - g$$

In this form the equations are used in the construction of trajectories by the method of numerical integration.

By reference to (1) we see that

$$(11) \quad E = \frac{G(\theta) H(y)}{C}$$

In this equation,  $G$  is a function of the velocity alone, as given in Table I.  $H$  is a function of the altitude alone as given by equation (2).  $C$  is a function of the weight and form of the projectile as given in equation (3). As in the older ballistic methods,  $C$  implicitly includes unknown variations from standard conditions in such quantities as density of the air, moisture in the air, temperature of the air, yaw of the projectile, i.e. angle between the longer axis of the projectile and the tangent to the trajectory.

However, for the purpose of the construction of ballistic tables, as distinguished from range tables, atmospheric conditions are assumed normal and trajectories are constructed with known values of  $C$ . In the construction of range tables by the use of ballistic tables or by direct calculation, changes in air density at the gun are accounted for by a factor  $D$  representing the density placed in the denominator of the expression for  $C$ , equation (3), and changes in form of head, yaw, etc., by the factor  $i$ , in that expression. As used hence the term "yaw" means the divergence of the axis of the projectile from the tangent to the trajectory, both on account of initial instability and of curvature of the trajectory away from the direction of the axis at a later period.

**Example of Numerical Integration.**—To illustrate the manner in which equations (9) and (10) may be integrated numerically, we shall assume an example as follows:

**Example 1.**—A 155 mm. gun fires a projectile having a ballistic coefficient of 3.6, with an initial velocity of 2,400 ft. per second, at an angle of elevation of 30 degrees. To determine the elements of the trajectory, assuming normal atmospheric conditions:—

The values of  $G$  and  $H$  are given in metres-per-second velocity and metres height respectively, so that all velocities and distances must be reduced to metres.

**Initial Conditions.**—At the gun we have  
 $v = 2,400$  ft. per second = 731.5 metres per second  
 $\theta = 30^\circ$   
 $x' = 731.5 \cos 30^\circ = 633.5$   
 $y' = 731.5 \sin 30^\circ = 365.8$   
 $\gamma = 0$ .

Since  $\frac{v}{100}$  is 3.351, the value of  $\log G(v)$  from the  $G$  table is 9.4515.

Since  $y$  is 0,  $H(y) = 1$ .  
 Placing logarithms in brackets, we then have

$$E = \frac{(9.4515 - 10)}{3.6}$$

and

$$E x' = \frac{(9.4515 - 10) \times 633.5}{3.6} = 49.78 = -x''$$

$$E y' = \frac{(9.4515 - 10) \times 365.8}{3.6} = 28.74$$

and

$$E y'' + g = 28.74 + 9.81 = 38.55 = -y'''$$

At the start, then, the horizontal velocity of the projectile is decreasing at the rate of 49.78 metres per second and the vertical component of the velocity is decreasing at the rate of 38.55 metres per second.

**First Interval—First Approximation.**—If we take a small interval of time, we do not make any great error in assuming that the retardations during the interval can be based upon the velocity and altitude at the beginning of the interval. Taking a  $\frac{1}{2}$ -second interval, the change in components of velocity is 12.4 and 9.6 metres respectively, making the velocities at the end of the first interval,

$$x' = 633.5 - 12.4 = 621.1$$

$$y' = 365.8 - 9.6 = 356.2$$

These velocities are lower than those that actually exist at the end of the interval, since the retardations are based on the components of the velocity at the beginning of the interval, and are consequently higher than the true average values during the interval. Using the velocity figures just obtained, we find the following values corresponding to the end of the first interval,

$$\frac{v^2}{100} = \frac{(621.1)^2 + (356.2)^2}{100} = 5126$$

$$y = \frac{365.8 + 356.2}{2 \times 4} = 90.2 \text{ metres}$$

$$G(v) = (9.4464 - 10) \quad \text{(from equation (2))}$$

$$H(y) = (9.9959 - 10)$$

$$E x' = \frac{(9.4464 - 10) (9.9959 - 10) \times 621.1}{3.6} = 47.78$$

$$E y' = \frac{(9.4464 - 10) (9.9959 - 10) \times 356.2}{3.6} = 27.39$$

$$E y'' + g = 27.39 + 9.81 = 37.20$$

**Second Approximation.**—The values of the components of retardation at the beginning of the interval are based on the velocity at the beginning of the interval and are, therefore, higher than the average values during the interval. The values just obtained for the components of the retardation at the end of the interval are based on a velocity lower than the true one at the end of the interval and are, therefore, lower than the average retardation during the interval. Means between these two sets of retardation components are nearer the average values during the interval than either set. The retardations for the  $\frac{1}{2}$ -second interval based on the mean values are,

$$\frac{49.78 + 47.78}{2 \times 4} = 12.2 = -x'''$$

$$\frac{38.55 + 37.20}{2 \times 4} = 9.5 = -y'''$$

making the velocities at the end of the first interval,

$$x' = 621.3$$

$$y' = 356.3, \text{ and the altitude,}$$

$$y = \frac{365.8 + 356.3}{2 \times 4} = 90.3$$

If we now take these values and recompute  $E x'$ ,  $E y'$  +  $g$  we find the values 47.80 and 37.21 respectively. In the average components of retardation during the interval no essential change will be found, showing that by a second approximation we have reached a result sufficiently accurate.

**Second Interval.**—Beginning with the components of the velocity and the altitude of the projectile at the end of the first interval we may now proceed in like manner to determine the components of the retardation during the second  $\frac{1}{2}$ -second interval. However, we may shorten the work as we now know not only the values of the retardation components at the beginning of the second interval but also the amounts by which they have changed in the preceding  $\frac{1}{2}$ -second. If the same rate of change continues during the second interval we will have for the end of that interval,

$$E x' = 47.78 - (49.78 - 47.80) = 45.82 = -x''$$

$$E y' - g = 37.21 - (38.55 - 37.21) = 35.87 = -y''$$

The corresponding velocities obtained by using the average retardations during the interval as before are:

$$x' = 609.6, \text{ and } y' = 347.2$$

The altitude at the end of the second interval is

$$y = 90.3 + \frac{356.3 + 347.2}{2 \times 4} = 178.3$$

Using the last values and again computing retardation components we have

$$E x' = 45.94$$

$$E y' + g = 35.98$$

Velocities and altitude computed from these do not differ from the values obtained in the first approximation, showing that a second approximation is unnecessary in this case.

**Continuation of the Process.**—Using exactly the same methods, it is possible to determine numerically, step by step, the values of  $x$ ,  $y$ ,  $x'$ ,  $y'$ ,  $x''$ , and  $y''$ . We might also determine  $x$  at each step, but it is not needed in making the step-by-step calculations and is usually more conveniently determined by a summation of  $x'$  after all the other values have been determined.

**Length of Interval.**—In the above example it was assumed that the change in  $x$ ,  $y$ ,  $x'$  or  $y'$  could be found by using the mean of the values of  $x'$ ,  $y'$ ,  $x''$  or  $y''$  at the beginning and end of the interval. To do this without making too large an error we must use a small interval or take account of second differences. The choice of length of interval will depend upon the ballistic coefficient, muzzle velocity and curvature of the trajectory at the point considered. If these, in combination, or separately, are such as to cause rapid changes in the components of the velocity or acceleration, a relatively short interval should be taken, as  $\frac{1}{2}$ -second in the examples above. Otherwise, the interval may be increased to  $\frac{1}{2}$ -second or longer, and when second differences are used, as will be explained below, to two or more seconds.

High velocities or low ballistic coefficients usually require smaller intervals than low velocities or high ballistic coefficients. It will in general be desirable to take a shorter interval at the very beginning of the trajectory than at a later period. In changing to longer intervals it is most convenient, in the computations, to take twice the interval just used. As the velocities increase in the descending branch of the trajectory it may be desirable in some cases to use shorter intervals again. If so, half the length of interval just used should be assumed.

**Second Differences.**—The length of interval may be increased and the amount of computation materially reduced if second differences are taken into account in computing all of the functions of  $t$ , as  $y$ ,  $x'$ ,  $y'$ ,  $x''$  and  $y''$ .

The following table shows the results of further computations on the example discussed above and gives first and second differences of  $y'$  for intervals of one second.

$t$	$y$	$y'$	1st Diff.	2nd Diff.
0	0	365.8	36.0	
1	347.5	329.8	31.7	4.3
2	661.2	298.1	28.2	3.5
3		269.9		

In determining the value of  $\Delta y$  from the average vertical velocity for the interval between  $t=2$  and  $t=3$ , we obtain, if we neglect second differences,

$$\Delta y'_{t=2} = \sum_{t=2}^{t=3} y' \Delta t = (269.9 + \frac{1}{2} \times 28.2) \times 1 = 284$$

The following figure showing  $y'$  plotted on an exaggerated scale, as a function of  $t$ , illustrates the error obtained if only first differences are used. The area of the figure between  $t=2$  and  $t=3$  is the value of  $\Delta y$  determined by using first differences only, these two as well as other consecutive points on the  $y'$  line being connected by a right line.



It is evident that the area of the figure between any two ordinates is greater than if the known  $y'$  points were connected by a smooth continuous curve.

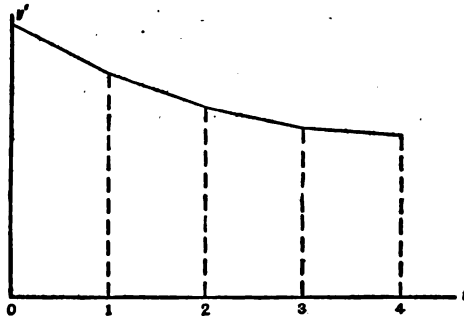

FIG. 3.

It has been shown mathematically that when the points  $t_0, t_1, t_2$ , etc., are equally spaced the quantity in brackets in the value of  $\Delta y$  above should be reduced by  $1/12$  of the second difference, making it,

$$\Delta y_i^2 = \frac{1}{2} (269.9 + 28.2 \times \frac{1}{2} - 3.5 \times \frac{1}{12}) \times 1 = 283.7$$

or more generally, since the same process is used in successively evaluating the other functions  $x', y'$ , etc., we may write,

$$(12) \int_{n-1}^n f_i(t) dt = (s_n + \frac{1}{2} s_{n-1} - \frac{1}{12} \delta_{n-1}) h$$

where  $f_i(t_n) = s_n, f_i(t_{n-1}) = s_{n-1}$  etc.  
 $n$  represents the order of the interval, or of the tabulated values of  $s, \alpha$  and  $b$ .  
 $h$ , the uniform length of the interval  
 $\alpha$ , first differences of  $s$   
 $b$ , second differences of  $s$ .

The quantities may be arranged in tabulated form as follows:—

$t_0$ .....	$s_0$ .....	$\alpha_0$ .....	$b_0$ .....
$t_1$ .....	$s_1$ .....	$\alpha_1$ .....	$b_1$ .....
$t_2$ .....	$s_2$ .....	$\alpha_2$ .....	$b_2$ .....
$t_3$ .....	$s_3$ .....	$\alpha_3$ .....	$b_3$ .....
$t_4$ .....	$s_4$ .....	$\alpha_4$ .....	$b_4$ .....

The application of the formula will give the successive increments to be applied in evaluating  $\int z dt$ .

The use of second differences in this manner permits the use of longer intervals except at the beginning when no second differences are available. In this case a shorter interval is used and a sufficient number of trials are made or a second difference is estimated by approximate methods.

The integral having been obtained by the methods described, up to any interval, Simpson's rule or other similar method may be used to check the values obtained.

**Complete Solution of a Trajectory.**—The results of the complete solution of the following example are given in Table II. below:—

**Example II.**—A 75 mm. gun is fired at an angle of departure of  $45^\circ$ , using a projectile of 15 lb. weight with a form factor,  $i=0.6$ . The muzzle velocity is 2,175 ft. per second. Determine the coördinates of the trajectory and the horizontal and vertical components of the velocity and acceleration.

TABLE II.

$\phi=45^\circ$		C=2.867		M.V.=2175 f/s=662.94 m/s			
$t$	$z$	$x'$	$Ex'$	$y$	$y'$	$Ey' + g$	
0	0	468.77	43.81	0	468.77	53.61	
1	115.85	458.08	41.70	115.54	455.66	51.28	
	229.09	447.91	39.72	227.88	443.12	49.09	
	339.85	438.21	37.88	337.15	431.10	47.06	
	448.23	428.96	36.14	443.47	419.58	45.15	
1 1/2	658.33	411.70	32.97	647.76	397.90	41.66	
	860.18	395.94	30.13	841.63	377.87	38.55	
2	1054.50	381.52	27.58	1025.87	359.30	35.78	
	1241.91	368.32	25.27	1201.46	342.04	33.27	
3	1423.00	356.22	23.18	1368.12	325.98	31.01	
	1598.29	345.11	21.25	1527.32	310.99	28.95	
4	1768.26	334.93	19.49	1679.28	296.99	27.08	
	1933.36	325.60	17.86	1824.46	283.88	25.37	
6	2250.54	309.23	14.94	2096.18	260.06	22.36	
	2352.75	295.61	12.36	2345.51	239.02	19.79	

TABLE II.—Continued

$t$	$z$	$x'$	$Ex'$	$y$	$y'$	$Ey' + g$
8	2842.57	284.42	10.04	2575.01	220.36	17.58
9	3122.32	275.42	8.04	2786.90	203.73	15.75
10	3394.00	268.46	6.41	2983.00	189.73	14.31
11	3659.23	262.86	5.29	3164.77	178.98	13.26
12	3919.26	257.73	4.32	3332.27	162.12	12.53
13	4174.94	253.74	3.69	3485.19	149.88	11.98
14	4426.01	250.39	3.22	3623.16	138.11	11.58
15	4672.66	247.26	2.87	3765.54	126.69	11.27
16	4915.54	244.53	2.59	3886.64	115.54	11.03
17	5164.84	242.05	2.38	3996.71	104.61	10.83
18	5405.70	239.75	2.21	4095.94	93.87	10.66
19	5644.37	237.62	2.06	4184.51	83.28	10.52
20	5880.96	235.59	1.93	4262.52	72.82	10.40
21	6115.59	233.69	1.85	4330.16	62.47	10.30
22	6348.37	231.88	1.77	4387.50	52.22	10.22
23	6579.38	230.15	1.70	4434.64	42.07	10.11
24	6808.69	228.47	1.65	4471.67	32.00	10.03
25	7036.34	226.85	1.60	4498.67	22.01	9.95
26	7262.40	225.27	1.56	4515.72	12.10	9.88
27	7486.90	223.73	1.53	4522.89	2.25	9.82
28	7709.87	222.21	1.51	4520.24	-7.55	9.75
29	7931.33	220.72	1.49	4507.83	-17.26	9.68
30	8151.31	219.24	1.48	4485.74	-26.91	9.62
32	8586.89	216.33	1.44	4412.64	-46.03	9.49
34	9016.63	213.40	1.40	4301.69	-64.87	9.35
36	9440.42	210.38	1.32	4153.35	-83.42	9.20
38	9858.11	207.29	1.57	3968.23	-101.65	9.03
40	10269.50	204.07	1.65	3747.00	-119.52	8.83
42	10674.27	200.66	1.75	3490.45	-136.96	8.61
44	11022.01	197.04	1.87	3199.50	-153.92	8.34
46	11462.25	193.15	2.01	2875.18	-170.30	8.03
48	11844.41	188.95	2.19	2518.77	-185.99	7.64
50	12217.80	184.36	2.40	2131.80	-200.83	7.19
52	12581.57	179.34	2.62	1716.11	-214.69	6.66
54	12934.85	173.85	2.87	1273.82	-227.41	6.05
56	13276.66	167.87	3.11	807.33	-238.85	5.38
58	13605.98	161.43	3.33	319.31	-248.90	4.66
59	13765.72	158.05	3.44	68.14	-253.37	4.28
59.200	13808.10	157.12	3.47	0	-254.49	4.18

It is to be noted that  $\frac{1}{2}$ -second intervals are used from 0 to 1 second, half-seconds from 1 to 5 seconds, full seconds from 5 to 39 seconds and two seconds from 30 to 58 seconds. As this was so nearly the end of the trajectory, judging from the value of  $y$ , a single second interval was next taken to 59 seconds. The exact values of the other elements corresponding to  $y=0$ , or the end of the range, are obtained by interpolation. For this purpose it may be desirable to work out the values for an additional short interval.

For the terminal velocity we have,

$$v = \sqrt{x'^2 + y'^2}$$

For the angle of fall,

$$\tan \omega = \frac{dy}{dx} = \frac{dy}{dx} \cdot \frac{dt}{dx} = \frac{y'}{x'}$$

The results for the end of the range and maximum ordinate are:

Range = 13808.1 m = 15100.7 yd.  
 Terminal Velocity 299.1 m/s = 327.1 yd./s = 681.3 f/s  
 $\omega = \tan^{-1} 1.61972 = 58^\circ 18' 55''$   
 Max. Ord. = 4523.15 m = 4946.6 yd.  
 Range to Max. Ord. = 7538.2 m = 8243.9 yd.

**Ballistic Tables.**—Using the method of numerical integration described, we may construct a series of trajectories with the values of the muzzle velocity, ballistic coefficient and angle of elevation so chosen and spaced as to cover the field of guns and ammunition in actual use. By proper arrangement of the principal elements of the trajectories thus determined, it is possible to form tables in convenient form for use, from which by interpolation we may obtain the important elements of the trajectories corresponding to any given gun. Such tables have been constructed in France and America.

The American tables, constructed under the supervision of A. A. Bennett, consist of two main tables. The first table is a direct tabulation of the results of numerical integration of trajectories. For this purpose it has been found most convenient and economical of labour to assume a ballistic coefficient and velocity at the summit and construct the trajectory forward and backward from that point. The arguments in this table are the ballistic coefficient, the velocity at the summit and the ordinate from the summit. The table gives the corresponding values of  $x, x', y$  and  $t$  from summit forward and backward.

The second table is arranged with C,  $\phi$  and V as arguments and gives X, T, Y and the velocity at the summit.

**Assumptions Made in Construction of Ballistic Tables.**—In computing trajectories for use in the construction of these tables, the following assumptions were made:—

1. The earth is motionless.
2. There is no wind.

3. The atmospheric density varies with the altitude, according to the H function given by equation (2) and is standard at the muzzle.  
 4. The action of gravity is uniform in intensity, is directed toward the earth's centre and is independent of the geographical position of the gun. Its value  $g = 9.80$  metres per second.  
 5. The G function is a function of the velocity alone and has the values given in Table I.  
 6. The ballistic coefficient C is constant and known.

**Differential Variations.**—Range tables for artillery must give the data required to lay the gun to strike a target at any desired range, not only for certain conditions fixed as standard for that gun, but also for conditions varying considerably from the standard. The variation may be in the initial conditions as in muzzle velocity, ballistic coefficient, or angle of departure. The initial variations in the ballistic coefficient may be due to variations in the density of the air at the gun, variations in the weight of the projectile or variations in the coefficient of form. Again, the variations may be in subsequent conditions, as in the existence of a range or cross wind, in H(y) or the air density curve for the day, in the rotation and curvature of the earth. The latter is introduced as a variation since it is not considered in the calculation of basic trajectories for the construction of ballistic tables, but its effects are material at long ranges.

Ballistic tables having been constructed we may obtain by mere interpolation the important variations such as that in range caused by variations in the initial conditions. Such variations may then be tabulated in convenient form in the range table.

For variations due to abnormal subsequent conditions, it is necessary to make special calculations, whether these are to be incorporated in the ballistic tables, or merely in the range tables. It would be quite possible to calculate a sufficient number of trajectories under assumed abnormal subsequent conditions to enable one to tabulate in ballistic and range tables the variations due to changes in these conditions, but this procedure would require a tremendous amount of work.

Furthermore, a variation in, say the range, due to variations in conditions is the difference between the range under the normal conditions and the range under the abnormal conditions. If we determine the variations by determining each range separately and taking the difference we are introducing the errors in two large quantities into a small quantity. The percentage error in the latter will, therefore, be large.

In view of these considerations, it has been found desirable to consider variations in the elements of the trajectory due to variations from the normal conditions as functions of the variations from the normal conditions, using the same principles of numerical integration as are used in the solution of the differential equations of the trajectory.

**Equations of the Variations.**—Taking  $x$  and  $y$  as the coordinates at the time  $t$  of the original trajectory of which the differential equations are (9) and (10), let us assume that the coordinates of the modified trajectory corresponding to the same time are  $x + \xi$  and  $y + \eta$ ,  $\xi$  and  $\eta$  representing the variations, due to some cause other than wind, in the conditions under which the original trajectory was constructed.

Variations due to wind affect the relative velocity between the projectile and the air and, therefore, the value of  $E$ , independently of the variations in  $x'$  and  $y'$  and will be considered in a later section.

Under this assumption the coordinates of the modified trajectory should satisfy the equations:

$$(13) \quad x' + \xi' = -(E + \Delta E) \frac{x' + \xi'}{v} - g$$

$$(14) \quad y' + \eta' = -(E + \Delta E) \frac{y' + \eta'}{v} - g$$

If we combine these with equations (9) and (10), and neglect all terms consisting of products of the small quantities  $\xi$ ,  $\eta$  and their derivatives, and  $\Delta E$ , we obtain upon solution for  $\xi'$  and  $\eta'$

$$(15) \quad \xi' = -E \xi' - x \Delta E$$

$$(16) \quad \eta' = -E \eta' - y \Delta E$$

On substitution of the value of  $E$  obtained from equation (9), transposition and division by

$$(17) \quad \frac{x \xi' - x' \xi}{x^2} = -\Delta E$$

$$(18) \quad \frac{x \eta' - x' \eta}{x^2} = -\frac{y}{x} \Delta E$$

Since the first members are the derivatives of  $\xi/x'$  and  $\eta/x'$  respectively, we may express the integrals as follows:—

$$(19) \quad \frac{\xi}{x'} - \frac{\xi'}{x} = - \int \Delta E dt$$

$$(20) \quad \frac{\eta}{x'} - \frac{\eta'}{x} = - \int \frac{y}{x} \Delta E dt$$

or,

$$(21) \quad \xi = \frac{x \xi'}{x'} - x' \int \Delta E dt$$

$$(22) \quad \eta = \frac{x \eta'}{x'} - x' \int \frac{y}{x} \Delta E dt$$

Here  $\xi'$  and  $\eta'$  represent the amounts by which the initial components of velocity differ from  $x_0'$  and  $y_0'$  respectively.

This set of equations like (9) and (10) may be integrated by the method of numerical integration, but we must first obtain an explicit relation between  $\Delta E$  and  $\xi$ ,  $\eta$  and  $\eta$ .

**Effect of the Variations on  $E$ .**—Since by equation (11)  $E = \frac{GH}{C}$  we may write approximately,

$$(23) \quad \frac{\Delta E}{E} = \frac{\Delta G}{G} + \frac{\Delta H}{H} - \frac{\Delta C}{C}$$

Again

$$\Delta G = \frac{dG}{dv} \Delta v, \quad \frac{\Delta G}{G} = \frac{d \log G}{dv} \Delta v$$

and

$$\Delta H = \frac{dH}{dy} \Delta y, \quad \frac{\Delta H}{H} = \frac{d \log H}{dy} \Delta y$$

we may write the equation,

$$(24) \quad \frac{\Delta E}{E} = \frac{d \log G}{dv} \Delta v + \frac{d \log H}{dy} \Delta y - \frac{\Delta C}{C}$$

Now, (25)

$$\Delta v = \Delta \sqrt{x'^2 + y'^2} = \frac{\Delta(x'^2 + y'^2)}{\sqrt{x'^2 + y'^2}} = \frac{2x'\xi' + 2y'\eta'}{\sqrt{2x'^2 + y'^2}} = \frac{1}{v} (x'\xi' + y'\eta')$$

and  $\Delta y = \eta$ .

Consequently we may write,

$$(26) \quad \Delta E = E \left( \frac{1}{v} \frac{d \log G}{dv} (x'\xi' + y'\eta') + \frac{d \log H}{dy} \eta \right) + E \frac{\Delta C}{C}$$

The first term of the second member of this equation gives the part of  $\Delta E$  due to variations in the components of the velocity and of the height. The last term gives the part due to variations in the ballistic coefficient including variations in the air density. Equation (26) is based on the assumed law of retardation as given by Table I, and the assumed law of air density as given in Equation (2). There is no trouble, however, in making differential corrections for variations from these assumed laws.

The term  $\frac{d \log G}{dv}$  or  $\frac{1}{vC} \frac{dC}{dv}$  is found from the G function

Table I, and tabulated with  $\frac{v^3}{100}$  as an argument in Table III, below. If we assume for H the exponential formula given by equation (2) we have  $\frac{d \log H}{dy} = -.0001036$  a constant.

TABLE III.  
Values of  $\frac{1}{vC} \frac{dC}{dv}$

For use in making differential corrections.  
Argument  $v^3/100$  ( $v$  in metres). The expressions  $-.0423$ ,  $-.0378$ , etc. mean  $-.000423$ ,  $-.0000378$ , etc.

$v^3/100$	$\frac{1}{vC} \frac{dC}{dv}$	$v^3/100$	$\frac{1}{vC} \frac{dC}{dv}$
00			
200	-.0412	7,200	-.0875
400	-.0276	7,400	-.0865
600	-.0314	7,600	-.0855
800	-.0400	7,800	-.0845
1,000	-.0434	8,000	-.0836
1,200	-.0305	8,200	-.0827
1,400	-.0475	8,400	-.0818
1,600	-.0410	8,600	-.0810
1,800	-.0774	8,800	-.0802
2,000	-.0585	9,000	-.0794
2,200	-.0462	9,200	-.0785
2,400	-.0378	9,400	-.0777
2,600	-.0317	9,600	-.0771
2,800	-.0271	9,800	-.0764
3,000	-.0237	10,000	-.0757
3,200	-.0209	12,000	-.0693
3,400	-.0188	14,000	-.0637
3,600	-.0171	16,000	-.0586
3,800	-.0157	18,000	-.0534
4,000	-.0145	20,000	-.0488
4,200	-.0136	22,000	-.0446
4,400	-.0128	24,000	-.0411
4,600	-.0121	26,000	-.0380
4,800	-.0114	28,000	-.0354
5,000	-.0108	30,000	-.0332
5,200	-.0104	32,000	-.0311
5,400	-.0102		
5,600	-.0096		
5,800	-.0095		
6,000	-.0095		
6,200	-.0097		
6,400	-.0092		
6,600	-.0090		
6,800	-.0087		
7,000	-.0086		

**Integration of the Differential Equations of the Variations.**—By using equation (21) with (22) and (26) we make a step-by-step numerical integration for any assumed variation. The system requires a separate integration corresponding to each assumed variation of conditions in each trajectory. It is always assumed that the original trajectory has been constructed and that we know its elements. The integration may proceed forward or backward from any point, as at the muzzle or the end of the trajectory, where we know or may estimate the values of disturbing variations and the effects produced by them.

**Bliss's Method.**—As may be inferred, the method for computing differential corrections, just described, involves a large amount of work. A method discovered by Professor G. A. Bliss and improved by Dr. T. H. Gronwall, in which use is made of a system of linear differential equations adjoint to the linear differential equations of the variations, as given by equations (13) and (14), reduces the work required to the extent that after the original trajectory has been computed, one numerical integration of the system will suffice for the computation of the corrections for all the variations. The method is, therefore, invaluable when a large number of differential variations are to be worked out.

**Tabulated Differential Corrections in Ballistic Tables.**—Certain differential corrections are conveniently tabulated, in separate columns of ballistic or range tables, as follows:—

- (a) Range and deflection corrections for the rotation of the earth as functions of the geographical latitude of the gun, azimuth of the plane of fire, and the three standard parameters of the trajectory, muzzle velocity, angle of departure and ballistic coefficient.
- (b) Corrections in range for variations in assumed air density throughout layers at convenient altitude intervals.
- (c) Corrections in range for a component of wind in the plane of fire, throughout layers at convenient altitude intervals.
- (d) Corrections in deflection for a component of wind at right angles to the plane of fire throughout layers at convenient altitude intervals.

In addition, corrections for variations in initial components of muzzle velocity, and variations in ballistic coefficient, may be obtained by interpolation in the main columns of the tables. A variation in air density at the gun may be corrected for in this way by determining its effect on the ballistic coefficient and making the corresponding interpolation in the table. This assumes that any change in air density at the gun is accompanied by a corresponding change aloft according to the law given by the H function. Of the first list of variations referred to, more will be said below.

**Effect of Wind.**—Any wind acting on the projectile in flight may be resolved into two components: one along and the other perpendicular to the plane of fire. It is convenient to do this in considering the effects of winds, and we thus have range winds and cross winds.

**Uniform Range Wind.**—Corrections due to rear or head winds may be handled by equations (21) and (22) and (26). In using these equations we must merely remember to increase or decrease the velocity with respect to the ground by the wind velocity when it is desired to get from the Tables, I, or III, the corresponding functions. Aside from this, a correction due to wind may be handled in the same manner as a correction due to variations in any of the initial conditions, air density, etc.

**Variable Wind.**—The direction and velocity of the wind will seldom be uniform throughout the trajectory. The velocity of the wind and also its direction near the surface of the earth is frequently influenced by local causes, such as the presence of hills, trees, houses, etc., to such an extent as to give no indication of the true average values during the flight of the projectile. Under normal conditions the wind may change both in direction and velocity as we go upward. Cases in which there is complete reversal of the wind well within the maximum ordinate of the trajectory are not unusual. The change in direction may also be accompanied by a change in velocity. In the preparation of range tables it is necessary to correct in some way for the effect of this sort of wind. The method usually followed is to divide the air above the earth's surface into zones of height, say 250 metres. By observation, the direction and velocity of the wind in each zone are determined.

For any assumed trajectory let  $\Delta R_0$  be the range correction of a uniform range wind of 1 metre per second, acting throughout. Now, dividing the trajectory into zones of height (as shown in fig. 4) let  $\Delta R_1$  be the total range effect produced by a wind of 1 metre per second blowing in the first zone and no wind in the other zones. The  $\Delta R_1$  correction can be computed by numerical integration of equations (21) and (22) to the limits of the zone, using the 1 metre wind. With the corrections found for that point, the integration is continued in still air until the projectile again enters the first zone. With these last corrections and the wind again acting, the integration is continued and the final correction  $\Delta R_n$  determined.

In the same manner the correction  $\Delta R_2$  for a wind of 1 metre per second, acting in the second zone, and no wind in the other zones, is determined. We then have

$$(27) \quad \Delta R_0 = \Delta R_1 + \Delta R_2 + \dots + \Delta R_n$$

If  $u_1, u_2, u_3, \dots$ , represent the wind velocities in the various zones,

and  $\Delta R$  represents the total range effect due to them, we may put approximately

$$(28) \quad \Delta R = u_1 \Delta R_1 + u_2 \Delta R_2 + \dots + u_n \Delta R_n$$

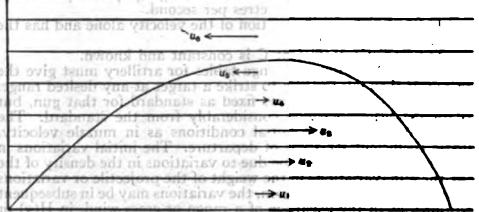

FIG. 4

In this equation some of the winds may be rear and others head, so the terms should be taken with their proper signs.

**Weighting Factors and Ballistic Wind.**—If we place

$$(29) \quad f_1 = \frac{\Delta R_1}{\Delta R_0}, \quad f_2 = \frac{\Delta R_2}{\Delta R_0}, \quad \text{etc.}$$

the ratios  $f_1, f_2$ , etc., are called weighting factors since they show the fractional part of the total wind effect that is produced in each zone. Using these factors we may write

$$(30) \quad R = (f_1 u_1 + f_2 u_2 + \dots + f_n u_n) \Delta R_0$$

The factor in brackets is the ballistic wind. It is the wind which, if blowing uniformly throughout the trajectory, would produce the same range effect that is produced by the variable winds actually blowing.

In the preceding discussion we have considered only rear or head, that is range, winds.

**Cross Wind.**—In the discussion of the trajectories so far given, no account has been taken of forces which tend to move the projectile from the plane of fire. Aside from drift, the principal cause of deflection from the plane of fire is the existence of a cross wind component. While the deflection due to drift is constant for any one trajectory for a given gun and projectile and is determined once for all by experiment, that due to cross wind varies with the velocity of the wind as well as with the elevation and azimuth of the gun. If we let  $x'$  represent the distance in metres the projectile is blown from the plane of fire at any instant by a cross wind  $w$ , distances and winds to the right being taken as positive, we will have  $x'$ , the velocity from the plane of fire, and  $x''$ , the acceleration produced by the component of air resistance normal to the plane of fire. The velocity of the projectile with respect to the air will be  $x' - w$ .

Now it will be sufficiently exact to consider the motion perpendicular to the plane of fire in the same manner in which we considered the horizontal motion in the plane of fire in equation (9), remembering that the velocity with respect to the air is  $x' - w$ . We may then write,

$$(31) \quad x'' = -E(x' - w)$$

Combining this equation with the relation  $x'' = -E x'$  from (9) we obtain after reduction and division by  $x'^2$ ,

$$(32) \quad \frac{x'' - x' - w}{x'^2} = -\frac{w}{x'^2}$$

Upon integration from 0 to  $t$  this becomes,

$$(33) \quad \frac{x' - x' - w}{x'^2} = -\frac{w}{x'^2}$$

or

$$(34) \quad x' = w \left( 1 - \frac{x'}{x'_0} \right)$$

Integrating again we obtain,

$$(35) \quad x = w \left( t - \frac{x}{x'_0} \right)$$

which makes the total deflection at the end of the trajectory,

$$(36) \quad Z = w T - \frac{w}{x'_0} X$$

In this expression  $w T$  is the total motion of the air with respect to the ground in the time of flight  $T$ . The deflection of the projectile is less than the motion of the air by the amount  $\frac{w}{x'_0} X$ , which is the deflection at the total range  $X$  that would be caused by a change of azimuth by the angle whose tangent is  $\frac{w}{x'_0}$ .

Cross wind weighting factors and the ballistic cross wind are determined in the manner described for range winds.

**Effect of Curvature of the Earth.**—While in the example of the numerical integration of a trajectory given above, and also in the construction of ballistic tables, the effect of curvature of the earth is not taken into account, it would be quite possible, still retaining

the system of rectangular coordinates with the  $x$  axis horizontal and the  $y$  axis vertical at the gun, to take account of the effect of curvature, both as it affects the direction lines of gravity and the height of site. Corrections due to curvature become important only at long ranges and then the most important is that due to height of site or the curvature of the earth away from the  $x$  axis. The correction angle at the gun due to curvature is one-half the angle at the centre of the earth subtended by the range.

**Correction for Rotation of the Earth.**—If a projectile is fired due east or west at the equator, it has, at the muzzle of the gun, not only the initial velocity with respect to the earth but also the velocity of the earth at that point. If the motion of the earth were one of translation alone, this fact would have no effect on the trajectory; but since the earth rotates around its axis and the rising projectile gets further and further away from this axis, an effect is produced upon the trajectory. This may be made more plainly evident if we assume the projectile to be fired vertically at the equator. With a motionless earth or one moving in right lines the projectile would fall back to the point from which it was fired. With a rotating earth the projectile has, at the muzzle, the vertical velocity given it by the gun, as well as the horizontal velocity of the earth's surface; as it rises it retains the latter velocity at all heights which it reaches. If we now consider points on that radius of the earth which passes through but above the muzzle of the gun we readily see that they have horizontal velocities due to the rotation of the earth in excess of those of the projectile at corresponding heights. It is evident, therefore, that the projectile will lag behind this radius and will fall to the earth west of the gun. A similar range correction will exist if the gun is fired east or west at the equator at any angle of elevation. The value of the correction is proportional to the angular velocity of the earth and the diameter of the equatorial section and depends besides upon the elements of the particular trajectory.

If the gun is fired along a parallel of latitude we have a somewhat similar condition, differing principally in that the velocity of the earth's surface is now less in the proportion  $\cos l$ , where  $l$  is the latitude. Now if the gun at the equator were fired along a meridian, the correction just referred to would no longer exist as a range correction but would become a deflection correction. For a gun fired at any point of the earth it may be shown mathematically that the corrections due to the causes above may be represented by functions of the form

$$\begin{array}{ll} \text{For range,} & A \cos l \sin \alpha \\ \text{For deflection,} & D \cos l \cos \alpha \end{array}$$

where  $l$  is the latitude,  $\alpha$  is the azimuth of the plane of fire measured from the south through the west, and  $A$  and  $D$  are functions whose values depend upon the trajectories.

The above corrections for both range and deflection arise from the lag of the projectile behind the surface of the earth due to its greater distance from the centre of the earth. Another consideration which gives rise to an additional deflection is the change in the velocity of the earth's surface with latitude. A projectile fired from the pole will be displaced by an angular amount depending upon the time of flight and hence by a linear amount approximately proportional to the product of the time of flight and the range. For a latitude  $l$  the deflection due to this cause is equal to that at the pole multiplied by  $\sin l$  and may be represented by

$$B \sin l$$

A rough value of  $B$  is  $\Omega X T^2$ , where  $\Omega$  is the angular velocity of the earth. The total displacements due to rotation of the earth are, therefore, given by the following equations:—

$$(37) \text{ Range displacement, } \Delta X = -A \cos l \sin \alpha$$

$$(38) \text{ Lateral displacement, } \Delta Z = B \sin l + D \cos l \cos \alpha,$$

where  $A$ ,  $B$ , and  $D$  are computed by integration from the data of each trajectory. It is in this way that range and deflection corrections for the rotation of the earth are worked for incorporation in ballistic tables. If air resistance is neglected the values of  $A$ ,  $B$ , and  $D$  may be worked out without integration and are:—

$$(40) \quad A = \Omega X T (\cot \omega - \frac{1}{2} \tan \phi)$$

$$(41) \quad B = \Omega X T$$

$$(42) \quad D = \frac{1}{2} \Omega X T \tan \phi.$$

Since  $A$  changes sign at  $\cot \omega = \cot \phi$  (in vacuum) or at  $\phi = 60^\circ$ , it follows that for this angle of departure in vacuum there is no range correction for rotation at any latitude or azimuth.

However, the resistance of the air markedly affects both range and deflection corrections due to the earth's rotation, and the approximate equations (40) to (42) applicable to trajectories in vacuum are not adequate for these corrections with long trajectories.

**Variations from Standard Air Density.**—In case the observed air density does not follow closely enough the assumed law of equation (2) we may divide the air into zones of height, as for variable wind, and determine air density weighting factors and a ballistic air density. The range correction for a variation in air density of, say, 10% from the normal is first worked out, it being assumed that the law of air density given by equation (2) holds throughout the trajectory. The partial corrections due to the same percentage variation in each zone are then worked out. The ratios of these partial corrections to the total correction are the weighting factors. When the weighting factors are multiplied by the observed densities in corresponding zones, corrected to their value at the

ground following the normal law, and the sum of the products for all the zones is taken, we have the ballistic air density.

**Effects of Temperature Variations.**—The temperature of the air affects both its density and its elasticity. In so far as it affects density, corrections in ballistic results, due to changes in temperature, are accounted for by the density correction, and when once the density is known no further reference need be made to temperature. The effect of temperature on the elasticity of the air is in addition to and almost independent of its effect on density. Elasticity of the air may be measured by the velocity of sound therein. This is known to increase as the square root of the absolute temperature and is only slightly affected by density.

In fig. 1 of the  $B$  curve above, note was made of the disturbance in the neighbourhood of the velocity of sound. If the velocity of sound is moved to the right or left on the  $V$ -axis by a change of temperature, the  $B$  curve will be similarly displaced and hence the  $E$  function used in equations (9) and (10) will be changed. With the quadratic resistance law, the  $B$  curve would be a right line parallel to the  $V$ -axis, and no change would be caused in  $B$ ,  $G$  or  $E$  by a change of temperature.

Trajectories used for ballistic table data are worked out for normal temperature

$$15^\circ \text{C.} = 59^\circ \text{F.} = 288^\circ \text{A., and are so tabulated.}$$

**Standard Temperature.**—It would be more logical if trajectories were worked out under some law of temperature gradient, similar to that assumed for the density gradient, equation (2). Taking account of the "gas law" derived from Boyle's and Charles' laws, the density law given by equation (2) and the theorem of static equilibrium which requires the difference in pressure at altitude  $y$  and sea level to be due only to the weight of the intervening layer, A. A. Bennett has arrived at the following formula for temperature aloft:—

$$\text{Temperature } \begin{cases} ^\circ \text{C.} = 50 - 35 \times 10^{-00004y} \\ ^\circ \text{F.} = 122 - 63 \times 10^{-00004y} \end{cases}$$

This represents fairly mean midsummer temperature in the United States. For mean midwinter temperatures subtract  $12.5^\circ \text{C.} = 22.5^\circ \text{F.}$  throughout. Corrections may be worked out to enable one to pass from the tabular data, based on constant temperature, to data based on the temperature gradient given by these equations.

**Rotation of Projectiles.**—Thus far we have considered the motion as merely that of a material point, or at any rate we have taken no account explicitly of the change in the air resistance which may result from the oblique presentation of an elongated projectile. If projectiles were perfectly spherical, formerly, there could be but one presentation or one critical exposed to air pressure, though the projectile might rotate in any direction.

Modern projectiles are given a motion of rotation by the rifling to prevent them from tumbling end over end and thus meeting with vastly increased and irregular air resistance. A projectile so designed as to place the "centre" of pressure in rear of the centre of mass, would doubtless travel head-on without having rotation. Attempts have been made to design such projectiles with some success as far as the ability to travel head-on is concerned; but it has always been necessary to increase the total head-on resistance, by the addition of a tail or similar device, to such an extent as to make them inferior to projectiles stabilized by rotation. Projectiles of this type are now used as bombs to be dropped from aircraft but are not fired from guns.

**Yaw of the Projectile.**—It has been determined by experiments that elongated projectiles do not always make round holes through cardboard screens called "jump cards" placed at short distances in front of the gun. By placing a sufficient number of these cards, it is found that the holes change in regular cycles, from greater to less and again to greater elongation. For a given round, certain positions of the jump cards, if thickly spaced, give holes of the greatest elongation, corresponding to the maximum yaws of the projectile, and certain other positions give holes of the least elongation corresponding to the minimum yaws. If jump cards are placed from near the gun up to 500 or 600 yd. from it, it will be found that the maximum yaws will diminish in value, the first one that appears in front of the gun being the greatest. By yaw is understood the angle between the direction of motion of the centre of gravity and the axis of the projectile.

In the *Aerodynamics of a Spinning Shell* by R. H. Fowler, E. G. Gallop, C. N. H. Lock and H. W. Richmond, F.R.S. (*Phil. Trans.*, series A, vol. 221), the authors present a very complete analysis of British jump-card experiments conducted by them. While the existence of initial instability of projectiles had long been known, knowledge of its laws and its effects on drift range and accuracy were vague, prior to these British experiments made in 1918.

**Causes of Yaw.**—A projectile fitting perfectly in the gun and having the centre of gravity of every cross section on the axis of figure, will move in the direction of that axis after leaving the muzzle, unless some force should start an angular motion of the longer axis. For the short distance with which we are here concerned the effect of gravity in curving the trajectory away from the axis is neglected. A projectile not fitting perfectly, or having its axis of figure not coincident with its dynamic axis, will yaw slightly in the gun. On leaving the muzzle it may receive an additional yaw from the powder

pressure against the base when the front bearing is unsupported, from the jump of the gun and from the powder blast.

Furthermore, at this point the air resistance begins to act in retarding the projectile. The action line of the resultant air pressure on a yawing projectile intersects the axis at a point in front of the centre of gravity. The resultant air resistance, therefore, exerts a moment around an axis through the centre of gravity, in such a direction as to increase the yaw. We then have a motion similar to that of a spinning top or gyroscope when an angular motion is given to the axis of spin, except that we have in addition a rapid motion of the centre of gravity.

In other words, the projectile has a motion of translation accompanied by precession and nutation. The motion of the point projected on a plane through the centre of gravity and normal to the trajectory, describes a rosette, as shown in fig. 5.

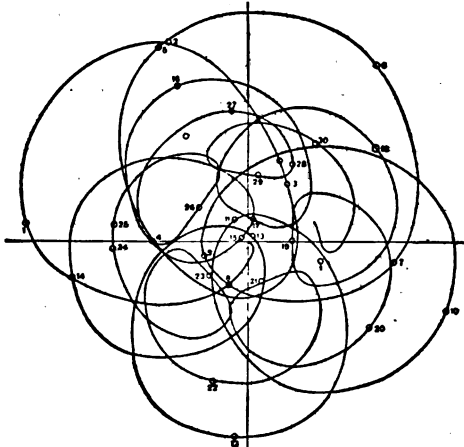

FIG. 5.

**Condition of Stability.**—If the spin is insufficient the air moment may cause the projectile to tumble. The condition of stability may be expressed by the following equation:—

$$s = \frac{A^2 N^2}{4B \mu}$$

where  $s$ , is the stability factor. Its value must be greater than 1.0 if the projectile is not to tumble, and not lower than 1.5 or 2.0 for modern projectiles, if excessive yaws are to be avoided.

$A$ , the moment of inertia of the projectile about the axis of spin,  $B$ , moment of inertia about an axis at right angles through the centre of gravity,

$N$ , the velocity of rotation about the longer axis in radians per second,

$U \sin \delta$ , the moment of the air resistance around an axis through the centre of gravity at right angles to the longer axis when the yaw is  $\delta$ .

The value of  $\delta$  depends upon the air resistance, but is nearly independent of  $s$  for small yaws.

$\delta$ , the angle of yaw.  
By an analysis of the results obtained in British and American jump-card experiments, R. H. Kent has determined that the value of the first maximum yaw outside the gun may be computed in terms of the stability factor and the yaw inside the gun by the following equation:

$$\alpha_1 = \frac{21}{A} \frac{\alpha}{1 - \frac{1}{s}}$$

where  $\alpha$  is the first maximum yaw  
 $\alpha$  the yaw in the gun.

Figure 6 shows the values of  $\alpha_1$  in terms of  $s$  for a value of  $\frac{1}{A} = 8$  and  $\alpha = 0^\circ.2$ .

It appears from this relation that the maximum yaw in front of the gun is principally due to the yaw in the gun, and that it is very little affected by the pressure of the powder gas, during the time the projectile is emerging from the muzzle, by the jump of the gun, or by the blast in front of the muzzle.

**Orientation of the Yaw.**—The plane of yaw contains the path of the centre of gravity and the axis of the projectile. The orientation of the yaw is the angle between this plane and the vertical plane containing the path of the centre of gravity. It is determined by measuring the angle between the traces of these two planes on the jump card. The precessional motion consists of rotation of the plane

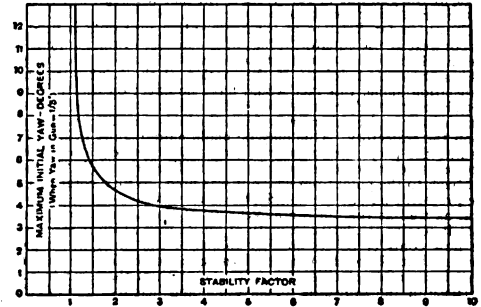

FIG. 6.

of yaw around the path of the centre of gravity, while the motion in nutation consists of oscillations around an axis through the centre of gravity normal to the plane of yaw.

For a small yaw not accompanied by nutations the rate of change of orientation is,

$$\alpha' = \frac{AN}{21}$$

The motion in nutation causes rapid changes in this rate in the neighbourhood of the minimum yaws.

**Damping of the Yaw.**—Reduction in the yaw of the projectile, as it proceeds down the range, is principally due to the following factors: (a) The component of the air resistance normal to the direction of motion of the yawing projectile causes motion of the centre of gravity in the direction of the yaw. The effect is a virtual reduction in the yaw accompanied by a helical motion of the projectile due to precession and nutation sets up an air-resistance couple which opposes that motion, and which is quite distinct from the air-resistance moment which causes the main part of the initial maximum yaw. The effect of the couple is first to damp out the nutations and finally to reduce the yaw; (c) as the velocity of the projectile decreases, the air resistance also decreases. The consequent reduction in the air-resistance moment on a yawing projectile causes a reduction in the maximum yaws.

**Effect of Yaw on Range and Accuracy.**—The resistance of a yawing projectile is very much greater than that of a projectile moving in the direction of its axis. Experiments made by G. F. Hull and L. J. Briggs in an air stream indicate that at a velocity of 200-300 metres per second the head-on resistance of a projectile of modern form yawing  $15^\circ$  is two to two and one-half times that of the same projectile moving in the direction of its axis. A considerable yaw in front of the gun will, therefore, cause a rapid reduction in the velocity and a reduction in range.

It is readily seen that a variation in initial yaw between rounds will cause bad range dispersion. The same is true of dispersion in deflection. It may be stated that irregularity in initial yaw, whatever may be its cause, forms one of the principal factors in dispersion of fire.

**Drift.**—As the projectile proceeds along the trajectory, its axis tends to remain parallel to its original direction at the gun. Since the effect of gravity causes the trajectory to curve toward the earth, there is a gradual increase in the angle between the axis of the projectile and the trajectory. This yaw, due to gravity, is quite distinct from the initial yaw described above and does not begin to have an important effect on the flight of the projectile until after the greater part of the initial yaw has been damped out.

A yaw having been developed by gravity, the air-resistance moment  $\mu \sin s$ , tending to rotate the spinning projectile in the plane of yaw, causes motion in a plane at right angles. The effect with right hand rotation of the projectile, is to cause the point of the projectile to move at first to the right of the plane of fire and at a later period downward, the projectile being bodily displaced by the component of air resistance acting normal to the direction of motion, on the side presented by the yaw. The initial instability and the drift are phenomena of like nature. While the initial instability is caused by a suddenly applied yaw, or a high rate of change of yaw, and is accompanied by a rapid motion in precession and nutation, the drift is caused by the gradual yaw due to the action of gravity on the projectile, and is accompanied by a very much slower motion in precession without nutation. (W. H. T.)

**BALLOON:** see AERONAUTICS.

**BALTIMORE** (see 3.288).—The pop. of Baltimore, the 8th city of the United States in number of inhabitants, increased in the decade 1910-20 from 558,485 to 733,826, of which number 208,390 in 1920 were negroes as compared with 84,749 in 1910. The 31.4 % increase in the total population represented in part a normal growth or one caused by the establishment of new industries, and in part an annexation (Act of Legislature of 1918) of 63.13 sq. m. containing several thickly settled manufacturing districts. This accession of territory increased the taxable basis of the city from \$915,433,444 in 1918 to \$1,086,349,852 in 1920.

**Manufactures.**—In 1914, Baltimore ranked 11th in the value of its manufactured products and 8th in the average number of industrial wage-earners among the 130 leading American cities. The capital invested in its manufactures was \$177,301,000; the value of its output was \$215,171,530, and its wage-earners in manufacturing plants numbered 73,769. There were 21 industries which exceeded one million dollars in value of product; the clothing industry led with products valued at \$4,482,136, while copper, tin and sheet iron (\$18,842,186), printing and publishing (\$10,283,775), cars and general shop construction (\$10,038,911), slaughtering and meat packing (\$9,503,883), and canning and preserving (\$7,879,125) followed in the order named. Unofficial figures (Board of Trade, Baltimore City) showed that from June 1 1919 to May 31 1920 100 new industries and 134 expansions of old industries increased the number of persons employed by 39,850 and added \$72,612,200, or 40 % to the manufacturing capital of the city. This great increase may be attributed to differential freight rate on goods from the west, deep-water manufacturing sites, steamship connexions, coastwise and foreign, and abundance of labour. Baltimore is a popular city with labour because in normal times its markets are notably cheap, and the continuance in Maryland of the ground-rent system makes possible the purchase of homes by labouring men on easy terms. In 1919 permits were granted for the construction of 3,700 two- and three-storey dwellings. Six hundred building and loan associations make it possible for labouring men to purchase easily houses of this type without hardship.

**Commerce.**—As an export port, Baltimore advanced notably in the amount of its business. In 1908 its exports amounted to \$82,113,496; its imports \$23,722,045. In 1918 the total value of domestic exports was \$300,144,011; in 1920 \$381,532,145. Its imports in 1918 were \$35,982,665, and in 1920 were \$69,885,165. In 1918 it exported 51,085,209 lb. of bacon and ham; 156,141,175 lb. of copper; 10,480,364 bus. of oats; 17,158,200 bus. of wheat and 76,879,176 lb. of leaf tobacco. In 1919, its wheat exports had increased to 25,501,321 bus. and its leaf tobacco to 149,529,865 pounds. Its principal imports in 1919 were copper (22,540,577 lb.), corkwood and waste (7,338,391 lb.) and mineral oil (300,296,000 gal.). In 1920, 1,809 vessels engaged in foreign trade (tonnage 5,218,089) cleared the port of Baltimore.

**Municipal Improvements.**—The physical characteristics of Baltimore were much altered during the decade 1910-20. By a paving loan of 1906, and by a special paving tax of 1912, funds were provided for the conversion of a "cobblestone city" into one with 210 m. of modern smooth paved streets at a cost of \$9,500,000. Three concrete tubes were constructed in the bed of Jones Falls, which had become an unsightly open sewer, and into these the stream and an additional flow of stormwater sewage were directed and carried through the city for a mile-and-a-half. On top of these tubes a highway was constructed, known as the Fallsaway, which relieved the congestion of north and south traffic between the water front and the up-town railroad yards. At a cost of \$23,500,000 the main work of installing a new sewerage system, begun in 1905, was completed in 1916. A dam at Lock Raven (2,000,000,000 gal. capacity) and a filtration plant at Montebello for impounding and purifying the Gunpowder river water supply were constructed. A general "City Plan," although only partly carried out by 1920, provided for the best treatment of all city utilities, streets, harbour, parks, railways, from an artistic as well as from a utilitarian standpoint. A civic centre was provided and Mt. Vernon and Washington Places, the setting of the Washington Monument, were completely changed in their landscape and decorative features. A boulevard, almost completely surrounding the city, connects the several parks.

**Annexation and Loans.**—One of the most important of all changes was the passage in 1918 of an Act of the Maryland Assembly by which to the 62.19 sq. m. of Baltimore territory were added 51.83 sq. m. of land and 11.30 sq. m. of water, making the total area 95.32 sq. m. and adding about 100,000 persons to the population. At the Nov. election of 1920, the people voted overwhelmingly in favour of four improvement loans, aggregating \$51,750,000, the several items of which were the Public Improvement Loan (schools, sewers, streets and bridges, harbour improvements, etc.) \$26,000,000; the Water

Supply Loan \$15,000,000; the Port Development Loan \$10,000,000; the Municipal Hospital Loan \$750,000.

**Finance.**—Fifty-seven Baltimore banks and trust companies exclusive of private banking firms showed Jan. 1 1920 aggregate resources of \$522,783,000 and deposits of \$414,453,000. In 1919 Baltimore was the 11th city in the country in bank clearings with a total of \$4,343,446,572, a gain of 29.4 % over the preceding year and of 91.6 % over 1917.

**Education.**—Notable progress was made by Johns Hopkins University in the decade 1910-20. The public library system of the city (the Enoch Pratt Free Library) which in 1910 had one central building, 12 branches and two stations, reported in 1920 the erection of six additional branches, and that plans had been accepted for the erection of four more branch buildings.

**Religion, Charity, Hospitals.**—In 1916 there were 494 religious organizations in Baltimore owning 455 places of worship, and church property valued at \$16,167,350. The total church membership was 296,599, approximately one-half the population. In numbers the Roman Catholic Church led with 137,730 members (100,397 in 1906), and following it in the order named came the Methodist Episcopal Church 30,217 (24,608 in 1906), the Baptist Church (National Convention, Coloured) 24,648 (16,081 in 1906), and the Protestant Episcopal Church 17,209 (16,812 in 1906). In 1915 all the charitable agencies formed an administrative association, the Baltimore Alliance of Charitable and Social Agencies, which coordinated the work of the individual organizations.

**History.**—The mayor of Baltimore from 1907 to 1911 was J. Barry Mahool, Democrat. From 1911 to 1918 the mayor, James H. Preston, and the City Council were Democratic. A Republican mayor, William F. Broening, was elected in 1918, but the City Council continued to be Democratic. In the World War the Baltimore militia organizations, the 4th and 5th Maryland Regts., were combined with the 1st Maryland to form the 115th Inf., U.S.A.; the Md. F.A. (3 batteries) became the 2nd batt. of the 110th F.A., U.S.A. Several smaller units followed these into the 29th Division and were trained at Camp McClellan, Ala. The infantry units of this division saw service at the front in France. Sixteen thousand five hundred men were raised by selective draft. Many of these received their training at Camp Meade, Md., and saw service at the front with the 79th Division; as the 313th Infantry Regiment.

**BIBLIOGRAPHY.**—United States Census Reports: *Manufacture, 1914; Religious Bodies, 1916; U.S. Census Bulletin, Populations Maryland, 1920; Statements on file in Office of Collector of the Port of Baltimore; General Message to the City Council of Baltimore, James H. Preston, Mayor, 1918; Statistics of Baltimore Board of Trade, 1920.* (L. C. W.)

**BANBURY, SIR FREDERICK GEORGE, 1ST BART.** (1850- ), British politician, was born in London Dec. 2 1850. He was educated at Winchester, and afterwards adopted a City career. He entered the Stock Exchange, and subsequently figured in various capacities as a director of companies. He successfully contested Peckham as a Conservative in 1892, and established his reputation in the House of Commons as a constant critic on business matters and also as an expert in parliamentary procedure. In 1902 he was created a baronet. He lost his seat in the general election of 1906, but was elected a few months later as one of the members for the City of London (re-elected 1918). In 1916 he was created a privy councillor, and in 1917 became chairman of the Great Northern railway.

**BANCROFT, HUBERT HOWE** (1832-1918), American historian (see 3.309), died at Walnut Creek, Cal., March 2 1918. He published in 1909-10 *The Book of Wealth* and in 1912 *Retrospection, Personal and Political*, the latter giving an account of his labours.

**BANCROFT, SIR SQUIRE** (1841- ), English actor and manager (see 3.309), made his last regular appearance on the stage as Count Orloff in a revival of *Diplomacy* at the Garrick theatre in 1893. The company were summoned to play before Queen Victoria at Balmoral Castle in Oct. of that year. He subsequently only appeared occasionally at special performances, the latest and most notable of which was at His Majesty's theatre, London, in Dec. 1918 when he played *Triplet in Masks and Faces*.

His wife, LANSY BANCROFT (1839-1921), died at Folkestone, May 22 1921. She had first appeared on the stage under her maiden name of Marie Etie Wilton at Manchester as *Floppa* in *Macbeth* and as Prince Arthur in *King John* as

<sup>1</sup> Import figures are for the U.S. Customs District of Maryland, of which the Port of Baltimore business represents approximately 95 %.



early as 1847. She made her début in London in 1856 with Charles Dillon at the Lyceum theatre as Henri in *Belphegor*. Her brilliant career as an actress, from the time when in 1865 she went into management at the Prince of Wales's theatre, and married Mr. (afterwards Sir Squire) Bancroft in 1868, came to a close in 1885, when she and her husband retired from the stage; but Lady Bancroft reappeared with him in the *Diplomacy* revival of 1893, and twice subsequently made a single appearance at a special matinee, the last occasion being the benefit performance for Miss Nellie Farren in March 1898.

**BANDELIER, ADOLPH FRANCIS ALPHONSE** (1840-1914), American archaeologist (see 3.311), died at Madrid March 19 1914. His last published works were *The Islands of Titicaca and Kooti* (1910) and *The Ruins of Tiakuanaco in Bolivia* (1912).

**BANERJEE, SIR SURENDRANATH** (1848- ), Indian orator, political reformer and journalist, was born Nov. 10 1848, a member of the Rarhi sub-caste of Kulin Brahmans, and the second son of a medical practitioner in Calcutta. Passing for the Indian civil service at the open competition of 1870, he was posted to Sylhet as assistant magistrate but, at the expiry of two years, was compulsorily retired on a small compassionate pension, on account of a technical irregularity—a decision since admitted generally to have been unjustly harsh. He then opened a small school in Calcutta which soon expanded into the well-known Ripon College. His work as a political reformer began in 1876 when he founded the Calcutta Indian Association, and three years later he became editor of the *Bengalee* newspaper. In subsequent years he became the centre of many stormy episodes. He was one of those who established the Indian National Congress in 1883, and presided over the Poona session of 1895 and again at the meeting at Ahmedabad in 1902.

From 1876 to 1899 he served on the Calcutta corporation, when he resigned with 27 other leading commissioners as a protest against the changes introduced by the Calcutta Municipal Act. In 1893 he was elected to represent the corporation on the Bengal Legislative Council, and was twice returned to the central Legislature as member for Bengal. He gave evidence in 1897 before the Royal Commission on Indian Expenditure and frequently visited England in connexion with deputations and political missions. Vehemently opposing the administrative partition of Bengal effected by Lord Curzon in 1905, he supported the boycott of foreign goods and the movement in favour of "national" education which arose from the upheaval. He always exhibited, however, a preference for constitutional agitation, and was among the first to welcome the Montagu-Chelmsford reforms. Severing his association with the Congress, which had passed under "extremist" control, he formed an "Indian Liberal" organization, and came to London in 1919 to present the case for his party before the Joint Parliamentary Committee, subsequently accepting office as Minister for Local Government and Sanitation in Bengal. A knighthood was conferred upon him in Jan. 1921. Possessed of a remarkable knowledge of the English language and literature, he had earned by his eloquence the title of the Gladstone of India. (H. E. A. C.)

**BANFFY, DEZSŐ [DESIDERIUS], BARON** (1843-1911), Hungarian statesman (see 3.315). In 1906 Bánffy, who had joined the coalition in opposition to the Government, broke with it on the military questions at issue with the King-Emperor, which he wished to eliminate, and in 1908 he became leader of the progressive elements and, as president of the Franchise League, began an agitation for universal, secret and equal suffrage (see 13.920, 921). In 1910 he became president of the Reform Club. He died May 24 1911.

**BANG, HERMANN JOACHIM** (1838-1912), Danish author (see 3.315), died Jan. 29 1912. In 1910 a volume of essays appeared, *Mosker og Mennesker*, followed in 1911 by a volume of short stories, *En delig Dag*. His collected works were published in six volumes in Copenhagen and Christiania (1912).

See F. Poppenberg, *Nordiske Portrætter—Hermann Bang* (1922).

**BANKING** (see 3.334).—I. UNITED KINGDOM.—British banking during 1910-21 underwent vast changes, not the least of which was seen in the direction of amalgamation. But even apart from that, the banks had grown in size, in importance, and in the extent of the territory covered by their branches. During this period, the great joint stock banks, which had generally been considered ultra-conservative in their methods, threw off to a large extent their mantle of aloofness; they even carried competition into foreign countries which a few years earlier had been thought to be closed to them for the establishment of branch banks. Whether their action is wise remains yet to be seen; for in some cases it was found necessary after a few years' experience of foreign banking to form separate companies for carrying out the operations of the foreign branch banks.

*Amalgamations.*—Amalgamation of banks or of finance houses was, of course, no new phenomenon; it dates back to the days of the old goldsmiths, when it was not unusual for a man to break adrift from one firm of goldsmiths for the purpose of joining forces with another more enterprising competitor, and slowly, but surely, the desire to strengthen their position by absorption or alliance spread to the private banks and later to the joint stock banks. However, it was not until the period between 1891 and 1896 that we find anything in the nature of a rush to create bigger banks through the process of absorption or amalgamation. During those five years a very large number of banks in the United Kingdom ceased to be separate entities, and the policy of amalgamation was steadily pursued up to the outbreak of the World War. There was then a slight pause in what we might call the race for supremacy among the larger joint stock banks; but the great and perplexing financial problems which arose during the war kindled afresh the desire for larger and yet larger banking concerns. Gradually, the lesser banks were drawn into the pool; then important institutions which had previously been regarded as free from the temptation to amalgamate, succeeded in persuading their shareholders that the time had come to incorporate their resources with those of the premier banks, and between 1917 and 1919, scarcely a month passed without the newspapers recording the merging of one large bank into another. The earlier absorption of local banks by larger and more widely spread joint stock-banks had created little more than passing interest among the public, but the policy of combination between the large joint stock banks themselves, many of them already possessed of enormous funds and branches spread over a wide area, caused a certain amount of concern in various directions, doubts being expressed as to its being to the public advantage, and in powerful business quarters the action of the banks was keenly criticized.

To investigate the matter a Treasury Committee was appointed on March 11 1918, and as the result of the deliberations of that committee the Government were recommended to pass legislation requiring that the prior approval of Government be obtained before any amalgamations were announced or carried into effect. Further, it was recommended that the approval both of the Treasury and of the Board of Trade should be obtained and that legislation should be passed requiring the two departments to set up a special statutory committee to advise them. These recommendations were carried into effect, and the new statutory committee set up; but either the objections of this body were easily met, or they found nothing to criticize in further unions, for by 1918-9 almost the entire banking strength of the country had become centred in five great combined institutions, the London Joint City & Midland Bank, Ltd., Barclay's Bank, Ltd., the London County Westminster & Parr's Bank, Ltd., the National Provincial & Union Bank of England, Ltd., and Lloyd's Bank, Ltd.

The date of the establishment of the London County Westminster & Parr's Bank, Ltd., is usually given as 1836, though as a matter of fact the London & Westminster Bank, which was the first joint stock bank established in London, was formed in March 1834. The London & County Bank was established two years later—in 1836. The actual date of the formation of Parr's Bank is not quite certain: there are records of its doing business as a private firm about 100 years ago, but as a joint stock bank it dates back no farther than 1865. Before the final amalgamation, each of the banks had obtained

a position of great importance by absorbing smaller banks, and when the London & Westminster Bank amalgamated with the London & County Banking Company, Ltd., in 1909 it was thought that the matter would rest there. Nine years later, however—in Feb. 1918, to be precise—a further addition to the strength of the combined institutions was made by the amalgamation with Parr's Bank, and the title of the bank was finally fixed as the London County Westminster & Parr's Bank, Ltd. As the bank now stands it represents six original clearing banks, viz., the London County & Westminster Bank; Jones, Lloyd & Co.; London & County Bank; Alliance Bank (subsequently changed to Parr's Bank); Fowler, Banbury & Co., and the Consolidated Bank. In Ireland the London County & Westminster Bank has affiliated with the Ulster Bank, Ltd., and it also has foreign auxiliaries in France, Belgium and Spain. The total number of banks and affiliations represented in 1921 was sixty.

The rise of the London Joint City & Midland Bank, Ltd., is no less remarkable. It was first established in 1836 as the Birmingham and Midland Bank, and although it absorbed a number of small banks from 1851 onwards, its first great step forward may be said to date from 1891, when it absorbed the Central Bank of London, Ltd., and adopted the new title of the London & Midland Bank, Ltd. Then, in 1898, it absorbed the old City Bank and again altered its name to the London City & Midland Bank, Ltd. Other amalgamations soon followed, and the principal absorptions were those of banks of such provincial fame as the Sheffield Banking Co., the North & South Wales Bank, and the Bradford Banking Co. Further additions were made by the purchase of the share capital of banks wider afield, and the bank now owns the Belfast Banking Co. and the Clydesdale Bank. The great amalgamation came, however, in 1918, when the London Joint Stock Bank, Ltd., which came into existence in July, 1836, was absorbed, and the title of the whole concern was changed to its present one of the London Joint City & Midland Bank, Ltd. As it now stands it represents what were formerly 65 banks.

Lloyd's Bank, Ltd., is remarkable for the series of amalgamations that have marked its rise to fame. The real origin of the bank can be traced back to 1765, although it was not incorporated as a joint stock bank until 1865. According to repute, it has taken over by amalgamation or absorption more banking concerns than any other similar institution. Including its affiliated institutions and foreign auxiliaries it represents a total banking strength of what were formerly 119 separate banks. Among some of the more important joint stock banks which this bank has absorbed during its career are: the Shropshire Banking Co., the Coventry & Warwickshire Banking Co., the Birmingham Joint Stock Bank, the West City & County Banking Co., Bristol & West of England Bank, and the Wilt & Dorset Banking Co. The great amalgamation came, however, when the Capital & Counties Bank, Ltd., was absorbed. The Capital & Counties Bank, as it happens, was itself established in 1834 and some six years later commenced to absorb other banks. In fact from 1877 to 1907 it acquired the business of no fewer than 26 other banks. Its career as a separate institution came to an end in the early part of 1918, when it was amalgamated with Lloyd's Bank, Ltd. Since then Lloyd's Bank has absorbed the West Yorkshire Bank and Messrs. Fox, Fowler & Co. of Somerset. It is also closely associated with the London & River Plate Bank and the National Bank of Scotland.

Barclay's Bank, Ltd., has an almost unique history. Until the year 1896 it was simply a private banking house carrying the name of Barclay & Co. Then it suddenly sprang into fame as being the originator of the amalgamations as we know them to-day. In 1896 the banking world was really taken by surprise by the announcement that Barclay & Co. had absorbed, at one sitting, 15 other private banks and had become incorporated at the same time. From that moment Barclay's progressed rapidly; the bank soon absorbed other institutions, such as the York Union Banking Co., Bolitho Williams & Co., Stamford, Spalding & Boston Bank, Ltd., and Neville, Reid & Co. The absorption of the United Counties Bank, Ltd., followed in 1916. A further large addition to its sphere of influence came in 1918 when the London & Provincial & South Western Bank was acquired, itself an amalgamation of two large joint stock banks. By this step over 250 branches in London and suburbs were added to its strength, and an interest acquired in the French subsidiary—Cox & Co. (France), Ltd. In 1919-20 Barclay's Bank extended its sphere still farther by affiliations with the Union Bank of Manchester, the British Linen Bank and the Anglo-Egyptian Bank, thus giving it a total banking strength of 102 banks.

The last of the "big five" is the National Provincial & Union Bank of England, Ltd. The National Provincial was itself formed in 1833, while the Union Bank of London, though not really established until 1839, can claim through one of its constituent institutions to date back to 1688. The principal absorptions for which the combined institutions have been responsible are: the County of Stafford Bank; Isle of Wight Joint Stock Bank; London & Yorkshire Bank; Briscoe's Bank; Smith, Payne & Smith's; Union Bank of London. The Union Bank of London, it is interesting to note, itself amalgamated with Smith, Payne & Smith's, London, Smith Elison & Co., Lincoln, Smith, Smith Bros. & Co., Hull, and Samuel Smith & Co., Derby, and the title was changed to the Union of London & Smith's Bank, Ltd., in 1902. The latter institution was amalgamated with the National Provincial Bank in 1917, the title adopted being the

National Provincial Union Bank of England, Ltd. The Sheffield Banking Co. was absorbed in Dec. 1917 and the Bradford District Bank on Jan. 1 1919. A year later an affiliation was made with Cox & Co., the well-known firm of private bankers who had themselves amalgamated with Robarts, Lubbock & Co. as recently as 1914. Finally, the National Provincial & Union Bank of England, Ltd., absorbed the Northamptonshire Union Bank, Ltd., in 1920. With its auxiliary bank, Lloyd's & National Provincial Foreign Bank, Ltd., this institution now represents what were formerly 63 banks.

The resources of the "big five" were, of course, very substantial before the amalgamations, and as the following table will show, there had been no diminution up to 1921:—

TOTAL CAPITAL, RESOURCES & DEPOSITS, 1913 AND 1920

	Dec. 31 1913	Dec. 31 1920
London County Westr. & Parr's Bk.	£143,000,000	£322,888,000
London City & Midland Bank	101,882,000	
London Joint Stock Bank	41,678,000	393,561,000
Lloyd's Bank, Ltd.	98,720,000	
Capital & Counties Bank, Ltd.	41,774,000	369,167,000
Barclay's Bank, Ltd. (June 1914)	66,940,000	351,631,000
National Provincial Bank		
Union of London & Smith's Bank	118,864,000	296,522,000

Just how the paid-up capital of the banks compares with that shown before the principal amalgamations took place will be seen from the following table:—

	Dec. 31 1921	Dec. 31 1920
London City & Midland Bk.	£3,989,238	
London Joint Stock Bank	2,970,000	£6,959,238
London County & Westr. Bank	£3,500,000	
Parr's Bank, Ltd.	2,204,780	5,704,780
National Provl. Bank of Eng.	£3,000,000	
Union of London & Smith's Bk.	3,554,786	6,554,786
Lloyd's Bank	£4,208,672	
Capital & Counties Bank	1,750,000	5,958,672
Barclay's Bank	£3,200,000	
London & Provincial Bank	800,000	
London & S. Western Bank	1,000,000	5,000,000
		11,760,811

The great upward movement in the amount of deposits held by the banks may be said to date from 1910; consequently, it will be of interest to place on record the deposits of the large banks in that year, and those at the end of 1921.

DEPOSITS OF ENGLISH BANKS AFFECTED BY THE AMALGAMATIONS

	Dec. 31 1910	Dec. 31 1920
London City & Midland Bk.	£221,635,807	
London Joint Stock Bk.	58,456,304	£280,092,111
Lloyd's Bank	£174,697,945	
Capital & Counties Bank	58,850,522	233,548,467
London County & Westr. Bk.	£147,433,697	
Parr's Bank	69,227,819	
Nottingham & Notts. Bank	5,723,389	222,384,905
Barclay's Bank	£129,067,901	
London & S. Western Bank	38,795,039	
London & Provincial Bank	36,307,726	204,170,666
National Provl. Bank	£112,780,401	
Union of London Bank	64,833,218	
Bradford District Bank	9,317,982	186,931,601
		278,335,365

Concerning the reasons for amalgamation, little need be said. The war undoubtedly drove the leading London bankers to look for increased financial resources, in order to cope with the increased magnitude of the operations they were being called upon to finance. Fashion, the desire to out-bid other institutions, the element of self-preservation, banking evolution, the conven-

ience and gain to trade to be secured by an extension of bank areas—all such factors, however, pulled their weight in what during 1918-9 offered to be a struggle for supremacy between the leading institutions. Probably the most naive reason advanced in justification for amalgamation was that of the chairman of one of the great banks, who said that "combination must come." This was a new variant of the old *petitio principii*, "it is coming because it must come and it must come because it has come." The remark, no doubt, truly reflected a sense of the inevitability of a further stage of evolution. Even so, to the most casual observer it would seem as if the voracious appetite of the supermen in banking had at last been satiated, for so great had been the absorptions that any further extension of the activities of the "big five" would of necessity be confined to the acquisition of the relatively unimportant private or merchant banks. In a word, amalgamation had spent itself by 1920, since any further fusion of the larger institutions would probably be regarded with suspicion by the general public.

As showing how the old private institutions have gone out of existence it may be said that out of 38 private banks which were doing business in 1891, there remained only four in 1921. The latest absorption up to the middle of 1921 was the acquisition in Feb. of that year of the business of Messrs. Fox, Fowler & Co., Somerset, by Lloyd's Bank. It was interesting as marking the passing of the last country bank which had the right to issue notes. Thus closed a remarkable chapter in English banking, for under the provisions of the Bank Charter Act of 1844, the right of issue lapsed on the amalgamation with Lloyd's Bank. Further, it marked the accomplishment of one of the principal aims of the Bank Act of 1844—that of reducing the private note issues of the country, for they now ceased altogether. In 1844 this note-issuing privilege was enjoyed by 207 private banks and 72 joint stock banks, and although the Bank of England was entitled to increase the fiduciary portion of its note circulation by two-thirds of the lapsed issues, the Bank had apparently not availed itself of the full privilege, for out of the maximum issue of £8,631,000 vested in the defunct banks, the Bank of England had only increased its fiduciary circulation by £7,551,000 of the lapsed issues.

Private banking, then, has found its resting place in the archives of the things that have been, and the lesser lights of English joint stock banks are not far behind. As a matter of fact the number of English joint stock banks was reduced from 106 in 1891 to 20 in 1921, and throughout the whole of the United Kingdom, including the Bank of England and the private banks, the number of banks had fallen from 111 in 1900 to 41 in 1921.

That the resources of the banks have not suffered by this process of absorption will presently be shown, for the question of resources is an all-important one. In many respects large banks are certainly preferable, because with large resources they are in a position to make advances on a much more generous scale than the smaller concerns. Moreover, it was clearly desirable that the banks should be prepared to adapt themselves to the entirely new order of things in the financial world brought about by the war.

Actually, the public would not appear to have suffered from the fusion of the banks, for if we make a comparison of the figures of the English joint stock banks (the Scottish and Irish banks, except in a minor degree, were not much concerned with amalgamation), we find that there have been very large increases in capital and reserves; the ratio of total cash to demand liabilities has risen, and deposits show a striking increase. The ratio of paid-up capital and reserves to deposits has, however, fallen considerably, though the 1920 figures showed that the upward movement had recommenced. The following table will reveal the true position:—

ENGLISH JOINT STOCK BANKS

	Paid-up Capital and Reserves.	Deposits.	Ratio of Paid-up Capital & Reserves to Deposits.	Ratio of Cash in hand, at call & notice to Liabilities.
1890	£ 67,826,000	£ 368,663,000	18.4	18
1895	69,213,000	455,501,000	15.3	19.9
1900	78,847,000	586,726,000	13.4	20.7
1905	82,010,000	627,529,000	13.1	23.6
1910	80,946,000	720,687,000	11.2	23.8
1913	82,068,000	809,352,000	10.1	24.3
1914	81,904,000	895,561,000	9.1	27.6
1915	81,731,000	992,555,000	8.2	22.9
1916	81,089,000	1,154,877,000	7.1	28
1917	84,475,000	1,305,297,000	6.2	28.0
1918	92,901,000	1,583,412,000	5.8	27.6
1919	106,273,000	1,874,184,000	5.7	21.3
1920	128,154,000	1,991,527,000	6.5	20.4

That there is no foundation for the accusation, sometimes heard, that the country had suffered from the closing of branch banks, is apparent from the fact that in 1890, when the fever for amalgamation had not taken so large a hold on the bankers, there were 104 banks in existence in England and Wales with 2,203 branches; by the end of 1920, with only 20 banks functioning, the number of branches had grown to 7,257.

In Scotland and Ireland, where the banks have preferred to strengthen their position and spheres of influence more by working arrangements with other large institutions than by actual union, the number of branches show similar expansion. Scotland in 1890 had 10 banks with 975 branches; in 1920 with only eight banks she had open 1,283 branches. Curiously enough, the number of banks operating in Ireland has not changed since 1890; there were then nine banks with 456 branches; in 1920, with the same number of banks the number of branches had exactly doubled, the total being 912. The capital and reserves of the Scottish banks in 1890 was £14,755,000; cash in hand, at call, etc., £21,427,000, against deposits of £91,610,000. By the end of 1920 the capital and reserves had grown to £17,917,000, cash in hand and money at call to £72,974,000, and deposits to £279,228,000. The capital and reserves of the Irish banks in 1890 was £10,374,000, cash in hand and money at call £9,086,000, and deposits £38,521,000. In 1920 the totals were: capital and reserves, £12,899,000; cash in hand, etc., £46,698,000; deposits, £200,441,000.

Just how great has been the extension of banking in the United Kingdom may be gauged from the following table, which shows the aggregate liabilities and assets of the banks in the United Kingdom for the pre-war period, 1913-4, and for the post-war period, 1920-1 and the respective increases involved. The figures for the Bank of England are included:—

	LIABILITIES		
	1913-4.	1920-1.	Increase.
Capital & Reserves	£ 131,629,000	£ 179,979,000	£ 48,350,000
Undivided Profits	6,705,000	8,858,000	2,153,000
Deposits	1,104,330,000	2,681,920,000	1,577,590,000
Acceptances	67,547,000	109,896,000	42,349,000
Notes, Bills, etc.	54,592,000	194,836,000	140,244,000
	£1,364,803,000	£3,175,489,000	£1,810,686,000

	ASSETS		
	1913-4.	1920-1.	Increase.
Cash in hand, money at call, etc.	£ 328,559,000	£ 708,622,000	£ 380,063,000
Investments	222,690,000	771,191,000	548,501,000
Discounts and advances	735,104,000	1,561,337,000	826,233,000
Premises and cover for Acceptances	78,450,000	134,339,000	55,889,000
	£1,364,803,000	£3,175,489,000	£1,810,686,000

*Increase in Deposits.*—Apart from the capital and reserves, which show what, in the circumstances, must be considered for 1920-1 the satisfactory increase of £48,350,000, or 36.7% over the 1913-4 total, the first item which strikes one's attention here is the enormous increase in deposits, £1,577,590,000, or 142.8% over the 1913-4 figures. The increase in deposits was common to most, if not all, of the banks during the war period, and after. Various reasons have been assigned for it. Some bankers gravely asserted that many of the balances which went to swell their deposits represented money awaiting employment in trade, but however true that may have been during the trade slump of 1919-20, the true causes during the war were to be found in the inflation arising out of the Government's war finance; while immediately after the war, bankers were certainly too free with their advances.

Each advance had the effect of adding to the deposits of the same or of some other bank in the country, since when a person raises a loan with a bank the amount is nearly always credited to his current account. Obviously, then, an increase in bank loans and advances is concomitant with an increase in bank deposits, and as the *Bankers' Magazine* pointed out in regard to the war period "bankers were able to extend their loans in this manner because a large proportion of the inflated deposits of the war period still remained with them as additional cash, notwithstanding the large sums which they invested in Treasury Bills or were prevailed upon to lock up in the various War Loans." Undoubtedly, the increase in deposits was largely due to the immense creation of Government credits, which eventually

found their way into the pockets of producers, traders and wage-earners, and so on, to the banks. However, by the summer of 1921 the rate of increase in both deposits and current accounts showed signs of slackening, and there appeared to be little doubt that, whenever trade started to revive, the deposits of all the banks would fall rapidly.

The increase in acceptances calls for little comment; it was falling steadily in 1921, and showed a decline of over £49,000,000 between 1920 and 1921.

**Credit Facilities.**—Discounts and advances gave the lie direct to the critics who averred that the assistance of the bankers to trade was not what it should be. Discounts and advances together showed the very satisfactory increase of £26,233,000, or nearly 11.2.4%, and it proved that even if the bankers were scrutinizing more carefully the applications for discounts and advances in 1921, they were giving very active assistance to the finance of trade and industry, so far as was compatible with the precautions they were bound to consider it wise to take in the interests of their depositors.

As a matter of fact, difficulties during the transitional period from war to peace were fully appreciated as long ago as 1916, when the Board of Trade appointed a committee to investigate the question of financial facilities for trade. Another committee was also appointed for similar reasons towards the end of 1917. The terms of reference to the latter body mainly consisted of (a) an inquiry into the financial needs of trade immediately after the war and the respect in which these needs would differ from the needs under normal conditions, (b) the provision of financial facilities to meet those needs. Briefly, the committee foresaw that there would be an increased demand for credit facilities during the reconstruction period, and that the character of the demand would differ from that of normal times in that it would consist of a greater demand for loans secured upon capital goods, compared with loans secured upon consumable goods. Further, the considered opinion of the committee on financial facilities in 1917 was, that to achieve the reconstruction of trade and industry on sound financial and economic lines, it would be necessary to reestablish a sound financial basis by means of an effective gold standard; to check any undue expansion of credit, and to take steps to reduce to more normal proportions the inflation of credit due to the war. In the banking world a movement towards this end had been gradually shaping itself, though progress up to 1921 had necessarily been slow owing to the bursting of the bubble of trade inflation, labour troubles, and world-wide depression in trade during 1920.

That there would be some difficulty in providing the extended credit facilities which, it was foreseen, would be necessary, was recognized, and to meet this difficulty the committee of 1918 recommended, among other things, an increase in the capital of the banks, and the acceptance of deposits for longer periods at fixed rates of interest. They said:—

"To enable the banks to do more in the direction of granting long trade credits, we are also of opinion that it is desirable that bankers should make more widely known their willingness to accept deposits for long periods, at fixed rates of interest. We believe that, if they were encouraged to do so, a number of depositors would be willing to deposit their money at fixed rates of interest, for periods of from one to five years, without the right of withdrawal. The removal of the liability to withdrawal would thus enable the banks to grant loans for longer periods."

To a limited extent, effect was given to these recommendations, and in 1921 the banks were all striving to meet the abnormal conditions with which they were faced.

The London branches of the colonial banks, of course, always favoured the taking of fixed deposits at a comparatively high rate of interest; but it is doubtful if the movement is destined to extend greatly among the London joint stock banks who are called upon to maintain greater liquid balances to meet withdrawals than are their colonial confrères.

One good thing towards the solution of the difficulty in providing adequate banking facilities for trade was that which arose out of the recommendations of the Board of Trade committee of 1916. As the result of the deliberations of that committee it was resolved to form a new bank to fill the gap which was said to exist between the home banks and the colonial and British-foreign

banks and banking houses. The new institution was called the British Trade Corporation. Its constitution and functions were laid down by the committee to be:—

(1) To have a capital of £10,000,000. The first issue to be from £2,500,000, upon which, in the first instance, only a small amount should be paid up, but which should all be called up within a reasonable time. A further issue to be made afterwards, if possible at a premium.

(2) It should not accept deposits at call or short notice.

(3) It should only open current accounts for parties who are proposing to make use of the overseas facilities which it would afford.

(4) It should have a foreign exchange department where special facilities might be afforded for dealing with bills in foreign currency.

(5) It should open a credit department for the issue of credits to parties at home and abroad.

(6) It should enter into banking agency arrangements with existing colonial or British-foreign banks wherever they could be concluded upon reasonable terms, and where such arrangements were made, it should undertake not to set up for a specified period its own branches or agencies. It should have power to set up branches or agencies where no British-foreign bank of importance exists.

(7) It should inaugurate an information bureau.

(8) It should endeavour not to interfere in any business for which banks and banking houses now provide facilities, and it should try to promote working transactions on joint account with other banks, and should invite other banks to submit to it new transactions which, owing to length of time, magnitude or other reasons, they are not prepared to undertake alone.

(9) Where desirable, it should cooperate with the merchant and manufacturer, and possibly accept risks upon joint account.

(10) It should become a centre for syndicate operations, availing itself of the special knowledge which it will possess through its information bureau.

The British Trade Corporation was designed to fill a gap in the financial machinery of the country and to supply needs which had been long felt by trade and industry. Apart from the assistance which it might be able to render in connexion with overseas contracts, the development of existing markets and the securing of new ones, its sphere of usefulness was a large one, and properly directed, it should prove of great value to the development of British trade, finance and industry.

**Foreign Banking.**—As a matter of interest in the trend of British banking it may be noted that all the large joint stock banks had entered by 1921 into more or less extended foreign relations. All had proper branches devoted entirely to the financing and developing of overseas trade, and foreign exchange operations formed a much more important part of the work of all London banks than had been the case before the war.

The ramifications of some of them were by 1921 very wide; Barclay's Bank, for instance, maintained a large foreign department in London and was also affiliated with the Anglo-Egyptian Bank. Lloyd's Bank, in company with the National Provincial Bank, had also its subsidiary in France under the title of Lloyd's & National Provincial Foreign Bank Ltd. The London County Westminster & Parr's Bank had a subsidiary bank called the London County Westminster & Parr's Foreign Bank, Ltd., and both Lloyd's and the London County Westminster & Parr's Bank were closely concerned in forming (1917) the British Italian Corporation in England and the Compagnia Italo-Britannica in Italy. The London Joint City & Midland Bank had formed no branches abroad, the view being that it was better to refrain from competing with foreign banks in their own centres; further, that besides being able to maintain amicable relations with foreign banks, a greater security was afforded to domestic depositors where the bank's activities were restricted to the home country. Some of the other banks who appeared to support this view had joined together and participated largely in the establishment of a bank known as the British Overseas Bank, which was making steady progress in the particular branch of banking for which it catered.

Altogether, then, whatever may have been the failings of the British Bankers up to 1910 in the provision of means for financing overseas trade, and in attending to the foreign exchange operations of their clients, there was in 1921 no lack of facilities for clients whose business called for operations in foreign and colonial currencies.

**War Services.**—A word remains to be said about the rise in the investment figures, which was a noteworthy feature of the aggregate balance sheets of the banks. The increase during the decade was £548,500,000, a little over 246%, and undoubtedly a large proportion of the investments in 1921 represented the bankers' subscriptions to the various war loans in which they had participated heavily. The banks' contribution to the Victory

and Funding loans alone, it was estimated, amounted to some £111,000,000. In June 1921, however, a small decline had recently been noticeable, and it seemed probable that, as time went on, the bankers would gradually divest themselves of a large portion of Government stocks.

Great services were rendered by the banks to the Government during the war. In most of the large loans that were floated the instalments were spread over a more or less lengthy period. In determining the amounts which the banks could conveniently handle account was taken of their reserve funds, which largely consisted of their deposits with the Bank of England. In describing the actual process of assisting the Government in this loan finance, the late Sir Edward Holden compared the payments with the revolutions of a wheel. The banks were described as placing in the wheel the payments they made for their customers who had subscribed for the loans; the wheel carried these payments to the credit of the Government with the Bank of England, and the subscribers received their securities. The Government then placed in the wheel cheques in payment of commodities and services rendered for conveyance to their creditors, and the creditors in turn used the wheel to carry the cheques to the credit of their accounts in the banks, thus reestablishing the banks' reserves and preparing them for another instalment. Another method by which the Government was helped by the banks was by the steady absorption of Treasury bills and other securities sold over the counter at the Bank of England. The banks also rendered invaluable service to the Government in making available their credit facilities with the Bank of England. "To increase their clients' ability and their own ability to invest in Government issues they would borrow from the Bank of England. These loans would increase their deposits with the Bank of England, which, as reserves, would increase their ability to grant to their own clients loans equivalent to, say, five times such deposits" (*English Public Finance*). Then in the advances to the Government on "Ways and Means" they were of important assistance. The manner in which these Ways and Means advances operated may be best described in the words of the Committee on Currency and Foreign Exchanges after the war:—

"Suppose for example, in a given week the Government require £10 million over and above receipts from taxes and loans from the public. They apply for an advance from the Bank of England, which by a book entry places the amount required to the credit of public deposits. The amount is then paid out to Government creditors, and passes, when the cheques are cleared, to the credit of their bankers in the books of the Bank of England—in other words, is transferred from 'Public' to 'Other' deposits, the effect of the whole transaction thus being to increase by £10 million the purchasing power in the hands of the public in the form of deposits in the joint stock banks and the bankers' cash at the Bank of England by the same amount. The bankers' liabilities to depositors having thus increased by £10 million and their cash reserves by an equal amount, their proportion of cash to liabilities (which was normally before the war something under 20%) is improved, with the result that they are in a position to make advances to their customers to an amount equal to four or five times the sum added to their cash reserves, or, in the absence of demand for such accommodation, to increase their investments by the difference between the cash received and the proportion they require to hold against the increase of their deposit liabilities. Since the outbreak of war it is the second procedure which has in the main been followed, the surplus cash having been used to subscribe for Treasury Bills and other Government securities. The money so subscribed has again been spent by the Government and returned in the manner described to the bankers' cash balances, the process being repeated again and again, until each £10,000,000 originally advanced by the Bank of England has created 'new' deposits representing new purchasing power to several times that amount."

It may be noted, in connexion with the part played by the great joint stock banks in the raising of war loans, that for the first time they were made collecting agents, being so named in the prospectuses with the Bank of England.

*Note Issues.*—The note circulation of the English joint stock banks remained in 1921 practically unchanged at £174,000. Scottish notes, it was found, were on the increase, while Irish notes showed a considerable decline. The expansion of the paper currency of the United Kingdom may be shown as follows,

the increases since 1913 being 279% for the Scottish, 206% for the Irish, and 349% for the Bank of England notes:—

(000's omitted.)

End of—	Scottish. £	Irish. £	Bank of England. £	Treasury Notes. £
1913	7,744	8,074	29,608	
1914	9,502	10,918	36,139	38,478
1915	12,555	15,000	35,309	103,123
1916	15,461	19,112	39,676	150,144
1917	19,023	22,336	45,944	212,782
1918	25,141	30,896	70,307	323,241
1919	28,032	29,054	91,350	356,152
1920	29,353	24,718	132,851	367,626

The total issue of the Bank of England against securities is known as the Fiduciary Issue, and on June 30 1914, the amount of this issue was £18,500,000, while the Bank of England notes issued against gold coin and bullion, under the provisions of the Bank Charter Act of 1844, amounted to £38,476,000. As showing how the bank's note issue increased during the war and the period following it, it may be observed that the notes in circulation on June 1 1921 amounted to £144,993,235, as security for which the Government debt amounted to £11,015,000, other securities to £7,434,900, giving an excess circulation over the authorized issue against securities of £126,543,235, all duly covered by the deposit of gold coin and bullion in the Issue Department.

The Committee on Currency and Foreign Exchanges after the war sat in 1918 and 1919, under Lord Cunliffe's chairmanship, to consider among other things the working of the Bank Act, 1844, and the constitution and functions of the Bank of England, with a view to recommending any alterations which might appear to be necessary or desirable. Briefly, the conclusion they came to was that the principles of the Act of 1844, which upon the whole had been fully justified by experience, should be maintained, namely, that there should be a fixed fiduciary issue beyond which, subject to emergency arrangements, notes should only be issued in exchange for gold. They said in their report:—"It is noteworthy that from 1866 till the outbreak of the war (1914) no suspension of the Act was ever necessary." The Committee considered that the stringent principles of the Act had often had the effect of preventing dangerous developments, and the fact that they had had to be temporarily suspended on certain rare and exceptional occasions (and those limited to the earlier years of the Act's operation when experience of the working of the system was still immature), did not, in their opinion, invalidate this conclusion. The Committee therefore recommended that the separation of the issue and banking departments of the bank should be maintained, and that the weekly return should continue to be published in its old form. The possibility of so modifying the Act of 1844 as to make provision for the issue of emergency currency in times of acute difficulty was, however, carefully considered. They said that it might, no doubt, be sufficient to leave matters as they were prior to 1914, and to risk the possibility of the law having to be broken, subject to indemnity from Parliament, but evidently the Committee were alive to the objections that had been expressed in many quarters to this procedure. Their report states:—"We are, therefore, of opinion that the provisions of Section 3 of the Currency and Bank Notes Act, 1914, under which the Bank of England may, with the consent of the Treasury, temporarily issue notes in excess of the legal limit, should be continued in force. It should be provided by statute that Parliament should be informed forthwith of any action taken by the Treasury under this provision by means of a Treasury Minute which should be laid before both Houses. The statute should also provide that any profits derived from the excess should be surrendered by the Bank to the Exchequer." The Committee add:—"It will, of course, be necessary that the Bank Rate should be raised to, and maintained at, a figure sufficiently high to secure the earliest possible retirement of the excess issue."

The following table records the changes in the Bank of England rate from 1911 to 1920:—

	No. of changes.	Highest.	Lowest.	Average.
1911	4	4½	3	3 9 4
1912	4	5	3	3 15 5
1913	2	5	4½	4 15 5
1914	8	10	3	4 0 9
1915	None	5	5	6 0 0
1916	1	6	5	5 9 3
1917	2	6	5	5 3 0
1918	None	5	5	5 0 0
1919	1	6	5	5 3 0
1920	1	7	6	6 14 4

A table may also be given showing (in thousands of pounds) the amounts presented through the London Bankers' Clearing House during the ten years ending in 1921:—

	Total Clearings.	Country Cheque Clearing.	Metro-politan Clearing.	On Consols Settling Days.	On Stock Exchange Account Days.
1911	14,613,877	1,221,420	796,386	678,652	2,218,700
1912	15,961,773	1,307,062	841,264	725,293	2,362,212
1913	16,436,404	1,389,481	855,648	781,892	2,082,031
1914	14,665,048	1,370,464	860,262	515,566	11,481,775
1915	13,407,725	1,567,571	929,004	589,654	1,025,775
1916	15,275,046	1,872,451	1,074,027	680,381	1,238,039
1917	19,121,196	2,244,190	1,177,478	881,824	1,521,194
1918	21,197,512	2,736,273	1,420,611	929,944	1,725,563
1919	28,415,382	3,386,768	1,813,929	1,296,734	2,316,266
1920	39,018,993	4,672,220	2,093,750	1,944,205	3,990,298

\*Seven settlements only. †Eighteen settlements only.

The Definition of a "Bank."—One good result of the British banking amalgamations which the critics of the policy nearly always overlooked is the elimination of the weaker vessels. Even a cursory glance at the figures will convince the reader that amalgamations have given added stability to the British banks, and this cannot but be beneficial to the general public and to the commercial community. The amalgamated institutions, moreover, have been unconnected with any failures; indeed, many times they have been the means of averting bankruptcies and panics. They came through the backwash of the American financial panic of 1907-8 with a firmly established reputation for that conservatism which means strength, and just as they emerged from the black times of the Baring crisis years ago, so have they passed through the critical periods of the war years, 1914-8, with added lustre. In the monetary stringency that befell Europe on the outbreak of war, and brought many of the European bourses on the verge of disaster, it was borne upon the public what a useful function is performed by the great banks of the United Kingdom in averting banking crises and creating confidence in British financial methods.

It is true that between 1910 and 1921 there were one or two failures which brought disaster to many of the poorer folk. But these failures were not by "banks" in any proper sense of the word. One was the Charing Cross Bank, which failed in Oct. 1910. It was nothing more or less than a money-lending concern. When it closed its doors it brought ruin to a large number of poor people who, tempted by high rates of interest, had deposited their savings with the institution. Practically nothing was saved from the wreck brought about by the folly of a man, named A. W. Carpenter, who was the sole proprietor of the concern. Then there was the Birkbeck Bank, which went into liquidation on June 8 1911, mainly through its connexion with building society finance. In this instance, the consequences were not so disastrous, since, largely as the outcome of the assistance of the joint stock banks in the liquidation, the depositors were ultimately paid nearly in full. More recently, on Dec. 20 1920, history repeated itself, and the public was startled by the failure of Farrow's Bank, an institution carried on under the chairmanship of Mr. Thomas Farrow, who was sentenced to four years' penal servitude in connexion with the publication of false balance sheets of the so-called bank. The failure of this bank caused little surprise in banking circles, but, as usual, a large

number of depositors of the small tradesman and artisan class were ruined by the failure. As with other institutions of this type, it was the same old story—the public lured by high rates of interest offered on current accounts and small deposits. When the bank failed it had succeeded in obtaining from the public approximately £1,458,000 in current accounts and £2,679,000 short deposits, and up to July 1921 all that it had been possible to pay to the depositors was *xs.* in the £, and there seemed no probability of anyone receiving more than *xs.* in the £ in final settlement.

In each case the failures gave prominence to the necessity for limiting the use of the title "bank" to institutions that really are banks. It also emphasized the necessity for the great joint stock banks to encourage the small depositor, with the result that most of them now advertise their willingness to open small deposit accounts at rates of interest consistent with prudent banking.

Immediately following the failure of the Charing Cross Bank the question was raised—"What is a bank?" and there was a demand for a definite ruling on the subject. It is curious, but true, that no Act up to 1921 had ever said what was the meaning of the word "bank," and what is still more curious, there was no decision of a Court of Law on this point. All the Bills of Exchange Act of 1882 says is—"A banker includes a body of persons whether incorporated or not, who carry on the business of banking"—a definition which has never had the slightest use in preventing scandals that have arisen in connexion with such concerns as the Charing Cross or Farrow's Bank. After the outcry in the press over the Charing Cross Bank failure in 1910 had died down, the subject was dropped, owing, it was said, to the difficulty of framing any satisfactory definition. The question was, however, raised again in 1911 on the amendment of the Money Lenders' Act, but with a similar result, and nothing useful was accomplished in the nature of preventive legislation. Then, in 1915, largely as the outcome of the banks' participation in the Government's War Loans, the question was again raised, and a small committee was got together by the late Lord Cunliffe to discuss the matter in anticipation of legislation. A report was made to the Bankers' Clearing House Committee, and the matter was continually discussed, off and on. The first definition proposed by the Clearing House Committee was this:—

"A Bank, as the term is understood in this country, may be broadly described as a firm or institution whose main business is to receive from the public monies on current account repayable on demand by cheque."

The objection to this definition, it was considered, lay in the words "main business," a general term which itself calls for explanation. It was urged that the main business of a bank is not in the receipt of money from the public, but in the relending of that money. Consequently, an alternative definition was proposed in the following terms:—

"The expression 'bank' means any persons who hold themselves out as carrying on the business of receiving from the public current account money which is to be repayable on demand by cheque, or who use the word 'bank' or any derivative of that word as part of the title or description under which they carry on business."

What, however, was considered to be even a better definition was that given by the president of the Institute of Bankers, London, Dr. Walter Leaf, in his address to the Institute of Bankers in Nov. 1920, namely:—

"The expression 'bank' means any persons who receive from the public on current account money which is to be repayable on demand by cheque, or who use the word 'bank' or any derivative of that word as part of the title under which they carry on business."

A good deal was said on the matter at the meeting in question, and most bankers present were in agreement with the president when he said that what actually was needed was a register of bankers which could be established without a hard and fast definition. Further, a tribunal should be set up with power to admit applicants or reject them from incorporation in the register on a wide view of all the circumstances of their business. This tribunal, it was argued, should be representative, not only of Government Departments, but of industry and commerce, as well as of existing banks. If such a register were set up no



one would be allowed to use the name of a bank or any derivative from it unless his name was included in the register. On all such registered banks such obligations as the publication of accounts, and so forth, would be imposed as might be thought desirable.

In the meantime the Government itself had in 1918-21 a bill under consideration which was intended to include the principal points put forward. But during 1921 it seemed to have found its resting-place in the archives of the Board of Trade.

Certainly the suggested register of bankers carries us a step farther than previous efforts have done. Sir John Paget, the eminent banking counsel, had constantly urged the necessity for reform in this matter, and in a letter to the *Journal of the Institute of Bankers* he pointed out in 1920 that the register plan offered finality where finality was sorely needed, elasticity where experience called for change. As he said, the register need not necessarily be either an Index Expurgatorius or a Book of the Righteous; it would be a true guide and friend. It would not be derogatory to bankers, for registration is both recognized and adopted in all professions. The Stock Exchange has its official list of members; the Law List is the register of counsel and solicitors, and when we come to medicine and surgery we find in the Medical Register and the General Medical Council the complete exemplar of a register and tribunal which, as Sir John Paget has argued very reasonably, might well be the pattern to be followed by the bankers. Unfortunately the blunder made by the Government in 1919 in introducing a "banks supervision" bill (for controlling amalgamation), which was so badly drafted that it had to be withdrawn, seemed to have discouraged official action.

**Overseas British Banking.**—The recent tendency of the English joint stock banks to take an interest in overseas banking has already been mentioned. Apparently, they had not yet in 1921 reached the point of carrying the process of amalgamation into unions with the colonial banks, though, as it happens, in 1919, *fourparlers* were taking place between representatives of Lloyd's Bank and the National Bank of India for the purchase of the shares of the latter. However, before the negotiations had reached a head the British Treasury intervened and vetoed the transaction. Nevertheless, there was an important development in India, namely the amalgamation of the three Presidency Banks, the Bank of Bengal, the Bank of Bombay, and the Bank of Madras, which, under an Act passed by the Indian Legislative Council in 1920, became united on Jan. 27 1921, and were henceforth to do business as the Imperial Bank of India. As is well known, the old Presidency Banks under the former régime were restricted in their operations; they were looked upon as semi-official institutions and as "bankers' banks." Under the Presidency Banks Act of 1876 they were prohibited from doing foreign exchange business, from borrowing or taking deposits payable outside India. They were not permitted to make loans for longer periods than six months, or to advance upon mortgage, or on immovable property, or upon promissory notes bearing less than two independent names, or upon goods, unless the goods or the title to them were deposited with the banks as security. Under the constitution of the new Imperial Bank of India, these disabilities are to a large extent removed; the bank is empowered to do most of the business which the Presidency Banks were formerly prohibited from doing. Besides acting as the bank for the Government, the Imperial Bank is permitted to have an office in London, and to rediscount bills for the Exchange Banks and other banks. It does not, however, compete with the Exchange Banks in ordinary exchange business. The appointment of the bank as the Indian Government's sole bank in India will make for economy, for it will enable the Government to abolish the expensive Reserve Treasuries in India, and the business hitherto conducted in that connexion by the Government will be done by the Imperial Bank. To render this possible, the Imperial Bank undertook to establish and to maintain within five years no fewer than 100 new branches, not less than one-fourth of which would be opened at such places as the Government might consider desirable.

It will be convenient at this point if we give particulars of the capital, etc., of the banks before the amalgamation and the position as it stood in June 1921.

**RESOURCES OF THE INDIAN PRESIDENCY BANKS BEFORE THEY WERE ABSORBED BY THE IMPERIAL BANK OF INDIA**  
(Lakhs of rupees.)

	Capital.	Re-serves.	Deposits.		Cash.
			Public.	Private.	
Bank of Bengal	200	210	388	3439	1244
Bank of Bombay	100	125	187	2650	980
Bank of Madras	75	45	124	2228	455
<b>Total</b>	<b>375</b>	<b>380</b>	<b>699</b>	<b>8317</b>	<b>2679</b>

(Figures are in lakhs of rupees—one lakh = 100,000 rupees)

**CAPITAL, ETC., OF THE IMPERIAL BANK OF INDIA, MAY 20 1921**  
(000's omitted.)

LIABILITIES.		ASSETS.	
	Rs.		Rs.
Subscribed capital	9,89,60	Government securities	9,56,82
Capital paid up	5,28,65	Other securities	1,38,40
Reserve	3,69,14	Loans	14,76,68
Public deposits	12,89,10	Cash credits	20,95,71
Other deposits	66,17,16	Inland bills	15,06,16
Loans against securities, per contra	16,87	Foreign bills	38
Sundries	1,11,25	Bullion	6
		Dead stock	2,09,04
		Sundries	37,39
		Balances with other banks	19,26
		Cash	24,95,27
<b>Total liabilities</b>	<b>Rs. 89,32,17</b>	<b>Total assets</b>	<b>Rs. 89,32,17</b>

The above includes:  
Deposits in London £ 34,500  
Advances in London 130,300  
Cash and balances at other banks in London 130,607

The establishment of this bank is, of course, a great step forward in the banking development of India; it centralizes the operations of three large banks, but gives them larger working resources and a much larger scope. A further advantage is found in the fact that although the Government is fully represented the main working of the central concern is in the hands of private individuals. The president and vice-presidents are the representatives of the shareholders, and practically the only Government officials on the central board are: the controller of the currency, not more than four nominees of the Government, and one or two managing governors appointed by the Indian Government in consultation with the central board. The first two governors were Sir N. Warren and Sir R. Aitken, who were formerly secretaries and treasurers of the Banks of Bengal and Bombay respectively, whilst the first London manager was Sir Bernard Hunter, who held formerly the position of secretary and treasurer of the Bank of Madras. Subsidiary to the central board, forming the main governing body, there were to be local boards, the latter being the existing boards of the amalgamated institutions in the three presidency towns. The central board was to function much in the same way as the Bank of England does in England. It deals with matters of general policy, "such as the movement of funds from one part of India to another, the fixation of the Indian Bank rate, which will in future be uniform for the whole of India, and the publication of the weekly statement."

The local boards, under the general control of the central board, were to have a very free hand in administering the affairs of the bank, and, altogether, the whole administration was designed to carry on the work of the previous Presidency Banks with the minimum of disturbance and the maximum of efficiency.

Precisely what business the Imperial Bank was in 1921 authorized to transact was set out in the following schedule of the Imperial Bank of India Act:

The bank is authorized to carry on and transact the several kinds of business hereinafter specified, namely:—

(a) The advancing and lending money; and opening cash-credits upon the security of: (1.) stocks, funds and securities (other than immovable property) in which a trustee is authorized to invest trust money by any Act of Parliament or by any Act of the Governor-General in Council and any securities of a local Government or the Government of Ceylon.

(II.) Such securities issued by State-aided railways as have been notified by the Governor-General in Council under section 36 of the Presidency Banks Act, 1876, or may be notified by him under this Act in that behalf.

(III.) Debentures or other securities for money issued under the authority of any Act of a legislature established in British India by, or on behalf of, a district board.

(IV.) Goods which, or the documents of title to which, are deposited with, or assigned to, the bank as security for such advances, loans or credits.

(V.) Accepted bills of exchange and promissory notes endorsed by the payees and joint and several promissory notes of two or more persons or firms unconnected with each other in general partnership.

(VI.) Fully paid shares and debentures of companies with limited liability, or immovable property or documents of title relating thereto as collateral security only where the original security is one of those specified in sub-clauses (I.) to (IV.), and if so authorized by any general or special directions of the central board, where the original security is of the kind specified in sub-clause (V.) provided that such advances and loans may be made, if the central board thinks fit, to the Secretary of State for India in Council, without any specific security.

(b) The selling and realization of the proceeds of sale of any such promissory notes, debentures, stock-receipts, bonds, annuities, stock, shares, securities or goods which, or the documents of title to which, have been deposited with, or assigned to, the bank as security for such advances, loans or credits, or which are held by the bank or over which the bank is entitled to any lien or charge in respect of any such loan or advance or credit or any debt or claim of the bank, and which have not been redeemed in due time in accordance with the terms and conditions (if any) of such deposit or assignment.

(c) The advancing and lending money to Courts of Wards upon the security of estates in their charge or under their superintendence and the realization of such advances or loans and any interest due thereon, provided that no such advance or loan shall be made without the previous sanction of the local Government concerned, and that the period for which any such advance or loan is made shall not exceed six months.

(d) The drawing, accepting, discounting, buying and selling of bills of exchange and other negotiable securities payable in India, or in Ceylon; and, subject to the general or special directions of the Governor-General in Council, the discounting, buying and selling of bills of exchange, payable outside India, for and from or to such banks as the Governor-General in Council may approve in that behalf.

(e) The investing of the funds of the bank upon any of the securities specified in sub-clauses (I.) to (III.) of clause (a) and converting the same into money when required, and altering, converting and transposing such investments for or into others of the investments above specified.

(f) The making, issuing and circulating of bank-post bills and letters of credit made payable in India, or in Ceylon, to order or otherwise than to the bearer on demand.

(g) The buying and selling of gold and silver whether coined or uncoined.

(h) The receiving of deposits and keeping cash accounts on such terms as may be agreed on.

(i) The acceptance of the charge of plate, jewels, title-deeds or other valuable goods on such terms as may be agreed on.

(j) The selling and realizing of all property, whether movable or immovable, which may in any way come into the possession of the bank in satisfaction or part satisfaction of any of its claims.

(k) The transacting of pecuniary agency business on commission.

(l) The acting as administrator, executor or trustee for the purpose of winding up estates and the acting as agent on commission in the transaction of the following kinds of business, namely:—

(I.) The buying, selling, transferring and taking charge of any securities or any shares in any public company.

(II.) The receiving of the proceeds, whether principal, interest or dividends, of any securities or shares.

(III.) The remittance of such proceeds at the risk of the principal by public or private bills of exchange, payable either in India or elsewhere.

(m) The drawing of bills of exchange and the granting of letters of credit payable out of India, for the use of principals for the purpose of the remittances mentioned in clause (I.) and also for private constituents for *bona fide* personal needs.

(n) The buying, for the purpose of meeting such bills or letters of credit, of bills of exchange payable out of India, at any usance not exceeding six months.

(o) The borrowing of money in India for the purpose of the bank's business, and the giving of security for money so borrowed by pledging assets or otherwise.

(p) The borrowing of money in England for the purpose of bank business upon the security of assets of the bank, but not otherwise.

(q) Generally, the doing of all such matters and things as may be incidental or subsidiary to the transacting of the various kinds of business hereinbefore specified.

The business which the bank was not authorized to carry out or transact was set out in Part II., which stated:—

The bank shall not transact any kind of banking business other than that specified in Part I., and in particular:—

(1) It shall not make any loan or advance (a) for a longer period than six months, or (b) upon the security of stock or shares of the bank, or (c) save in the case of the estates specified in clause (c) of

Part I., upon the mortgage or in any other manner upon the security of any immovable property, or the documents of title relating thereto.

(2) The bank shall not (except upon a security of the kind specified in sub-clauses (I.) to (IV.) of clause (a) of Part I.) discount bills for any individual or partnership-firm for an amount exceeding in the whole at any one time such sum as may be prescribed, or lend or advance in any way to any individual or partnership-firm an amount exceeding in the whole at any one time such sum as may be so prescribed.

(3) The bank shall not discount or buy, or advance and lend, or open cash-credits on the security of any negotiable instrument of any individual or partnership-firm, payable in the town or at the place where it is presented for discount, which does not carry on it the several responsibilities of at least two persons or firms unconnected with each other in general partnership.

(4) The bank shall not discount or buy, or advance and lend or open cash-credits on the security of any negotiable security having at the date of the proposed transaction a longer period to run than six months or, if drawn after sight, drawn for a longer period than six months.

Provided that nothing in this Part shall be deemed to prevent the bank from allowing any person who keeps an account with the bank to overdraw such account, without security, to such extent as may be prescribed.

The setting up of the Imperial Bank of India was an important step forward for India, and the results could not but be far-reaching. As the Government of India said in placing the scheme before the Secretary of State, the mere appearance in districts of a bank which would conduct the Government's Treasury and Public Debt business, and as to whose stability there would be no doubt, must in course of time have an appreciable effect upon the native attitude towards banking in general. Whether it would be successful in attracting large deposits from the hoards of wealth that are said to exist in India remained to be seen, but, at any rate, the other native banks would now have behind them a powerful central institution to which they could look for guidance, upon which they could rely for assistance, and which no doubt would form a necessary adjunct for the development of the various classes of banking in India, agricultural, industrial and joint stock banks. The internal trade of the country, too, could but benefit by the extension of branches which it was the declared policy of the Imperial Bank to set up.<sup>1</sup>

We may now turn from a consideration of this most important development in Indian banking to a similar stride forward in South Africa, in the establishment of the South African Reserve Bank, which received its charter under the South African Currency and Bank Act of 1920.

Like the Imperial Bank of India, it was to be a private institution, half the capital being subscribed by the banks doing business in the South African Union in proportion to their paid-up capital and reserve funds, and the other half provided by public subscription. If the applications from the public fell short of the 50% required, the balance would be made up from public funds. The bank was to be established first at Pretoria.

The affairs of the bank were to be managed by a Reserve Board consisting of eleven members, three being men experienced in banking and finance, and three (actively engaged in business at the time of appointment) representative of commerce, agriculture and industry. Three others were to be appointed by the Government. A governor and deputy-governor (who must be persons of banking experience) were to be appointed by the Governor-General and to hold office for five years. The person selected for the seat of the first governor was Mr. W. H. Clegg, who, prior to his appointment, was the chief accountant at the Bank of England.

Like the Federal Reserve system of America, the object of the new South African banking system is to consolidate the financial system of the country by centralizing the existing bank reserves. Further, the keeping of balances of other banks at the Reserve Bank will have the effect of making the central institution the sole custodian of the banking reserve of the country, a feature which is evidently modelled from the English system. The reserve regulations make the expansion of the note issue dependent on trade demands, and when the system is properly functioning it is expected there will be a much greater elasticity of the currency than formerly in South Africa.

For a period of 25 years from its inception the bank will have the sole right of issuing notes within the South African Union. The other banks are not ignored; they are given time to make arrangements regarding their own note issues; they will be allowed to continue the issue of their notes for 12 months, and if the Reserve Bank is then in a position to issue its own notes, they will be called upon to retire their notes gradually, and when all had lapsed (within two years,

<sup>1</sup> Cf. *Economic Journal*, June 1921.

it was hoped), the Reserve Bank would be the only bank of issue in the Union. However, the other banks' issues, even in the transitional periods, will require to be backed by a minimum gold reserve of 40%, and for any excess circulation over that of Dec. 31 1919, they will pay an additional tax of 3% per annum.

The South African Reserve Bank itself will be obliged to maintain a minimum gold reserve of 40% against its note issue, but the remaining 60% may be covered by commercial bills, and by a fixed charge on all the assets of the bank. Further, it must keep a minimum gold reserve of 40% against its deposits and bills payable.

The bank will act as the Government's bankers and financial agents, and will fix discount rates. It is empowered to set up branches in any part of the South African Union, and, subject to the consent of the Treasury, may also open branches outside the Union.

The business in which the bank may participate does not differ materially from that done by other banks within the South African Union, with this exception, that it will not be allowed to receive time deposits, nor to draw or to accept bills payable otherwise than on demand. The issuance of bills of exchange or promissory notes in which it will deal is limited to 90 days, except bills or notes arising out of agricultural finance, for which the issuance is limited to six months. However, all bills must bear at least two good signatures. Dealings in these six-months' bills are limited to 20% of the bank's total advances, so there is not much risk of such finance embarrassing the bank.

The principles of the other business allowed to be undertaken by the bank closely resemble those peculiar to the Bank of England, and most of the regulations governing it are designed with a view to giving the country the greatest possible financial assistance in times of crisis or of stress.

As this was the first central bank established in the British Dominions, its progress will be watched with keen interest both at home and abroad, and as Sir Henry Strakosch has said, "In the light of the experience gained by the central banks of Europe, the South African Act should be capable, under wise management, of adequately fulfilling the functions for which it was set up."

Another new development of importance in colonial banking since 1910 has been seen in the establishment in Australia in 1912 of the Commonwealth Bank. For the purpose of starting this bank a special Act of the Federal Parliament was necessary; it is called the Commonwealth Bank Act of 1911-4. The bank commenced business early in 1913, and by 1921 had safely survived the criticism to which, as a State bank, it was subjected. It has become one of the recognized financial institutions of the Commonwealth, and it has not only been a steadying influence to the Australian financial and banking position, but has given added stability to the banks in the Commonwealth, and has certainly strengthened the Commonwealth's position. It was, of course, the first State bank in the British Empire, and it is owned entirely by the Australian Commonwealth Government. The bank has no share capital and all its obligations are guaranteed by the Government. There is no board of directors, and the bank is considered to be free from political interference. Of necessity, however, the bank must be closely in touch with the Government. It is responsible for practically all the Government's business; it conducts the Government's savings banks at all its branches, and is largely responsible for 2,800 agencies at the Australian post-offices. It also undertakes the flotation of the Australian loans in London, and manages the Government stocks much in the same way as the Bank of England attends to Government issues. It is also responsible for the gold which is produced in Australia, and for the federal note circulation. The net profits of the bank are utilized in the building up of reserves; one-half of the profit is placed to the credit of a fund called the Bank Reserve Fund, and the other half to the credit of a reserve called the Redemption Fund. Each of these reserves stood in 1921 at £1,378,952. The Bank Reserve Fund is available for the liabilities of the bank, while the Redemption Fund may be utilized for repayment of any money advanced to the Australian Treasury or in the redemption of stock issued by the bank, but there is a proviso to the effect that if the fund exceed the amount of debentures or stock in existence, the excess may be used for the purpose of the redemption of any Commonwealth or State debts taken over by the Commonwealth.

During the eight years in which the bank had been in existence up to 1921 it had accumulated profits of £2,756,104; it started with the head office in Australia and one branch in London; it had in 1921 six offices in Australia, two in London, and over 300 branches and sub-branches in all the provinces of Australia, Tasmania and New Britain. Its deposits exceeded £41,000,000, added to which the

savings-bank deposits amounted to £17,982,000. Its total liabilities to the public on June 30 1920, were £66,658,600, against which assets were held in the following approximate proportions: cash, 10%; Australian notes, 3%; investments, 31%; bills discounted and advances, 24%.

Although the bank may be said to have justified its existence, the fact that the Australian Government, besides being the proprietor of the Commonwealth Bank, is largely interested in trade matters in Australia, is considered to militate against the best principles of central banking, and it seems likely that the Australians will watch the South African Reserve Bank and will possibly endeavour to develop their own system on rather different lines. The South African Bank, it is held, indicates a very hopeful road towards reform, and the system is certain to receive serious consideration from Australia and most other parts of the Empire. Critics have laid stress upon the advantages which the South African Reserve Bank will secure for the internal finance of the Union, and that really is what is wanted in Australia. The establishment of the South African Reserve Bank opens the door to imperial co-operation in banking and currency matters in a form and on a scale which had been difficult, if not impossible, up to 1921. From the imperial point of view the establishment of such a bank is an event of as much importance as from the international standpoint was the establishment of the United States Federal Reserve system, and it is to be hoped that further developments of the same nature will follow and so enable the British Empire to escape from the charge that co-operation between London and South Africa, London and Sydney, or between London and Montreal, presents greater difficulties than co-operation between London and New York.

Concerning the other banks in the Empire in which Great Britain is interested, we must be brief. To take the Canadian system first: it has certainly all the elements of elasticity, and the years that had elapsed between 1906 and 1921 proved its soundness. There were 18 chartered banks in 1921 with over 4,000 branches throughout the Dominion and Newfoundland. The banking and credit system, like that of the United Kingdom, is thus under the supervision of large banks with tried heads, and just as the "big five" in England are able to keep in close touch through their wonderful branch system with commerce in every part of the United Kingdom, so in Canada the chartered banks very efficiently collate the information needed concerning credit, commerce and industry. As has been well said by a Canadian writer, the "credit facilities of the Canadian Dominion, like the Bank Note issues, follow where the need exists and the situation is always under control. It is the case of a few men working together against many individuals working alone." The total assets of the chartered banks in 1921 exceeded \$3,091,500,000; their gold reserve stood at approximately \$80,000,000; deposits at \$2,319,600,000; notes in circulation \$280,700,000; deposits to secure the notes \$106,200,000; investment securities \$37,100,000; capital \$122,300,000, and rest \$128,700,000.

An interesting recent development in Canadian banking has been the establishment of branches or the forming of alliances in and with outside countries. With a view to giving the Canadian exporters every assistance, connexions have been sought in every place in the British Empire that promises a profitable field for Canadian products. The experience of Canadian bankers is, that instead of foreign branches cutting into the banks' capital and drawing funds away from local use, such branches have been instrumental in drawing in more deposits than have been given out in commercial loans. For instance, in 1920 it was found that loans, other than call loans, made outside Canada amounted to some \$183,600,000, while deposits from the general public outside Canada amounted to \$318,200,000. The South African banks seem to be finding out the same thing, for they have been extending their branches and banks in many outside colonies, dependencies and foreign countries.

The colonial banks with Eastern connexions, too, are developing the branch system in the colonies and foreign countries on a large scale. The Hongkong Shanghai Banking Corporation, the Chartered Bank of India, the Mercantile Bank of India and the National Bank of India, had in 1921 all been extending their sphere of influence in British Indian and Far Eastern markets, and nearly all of them were increasing their resources to meet the increased requirements. For instance, the Indian and Eastern banks established in London in 1920 (all British institutions) were possessed of capital and reserves amounting to £21,180,600. Their deposits totalled £204,894,000, and cash to £52,754,000, while their total assets amounted to over £200,000,000. Excluding the Imperial Bank of India, five of these Indian and Eastern banks had London offices in 1921, and the five had a total branch strength of over 130.

As showing how they compare with the other colonial banks in London, we conclude with the following details:—

Of African banks there are seven with 873 colonial branches; total capital and reserves £17,046,000; deposits of £189,892,000, and total assets, £249,250,000.

There are 16 Australian banks with 2,393 branches; total capital and reserves £51,248,000; deposits £281,477,000, and total assets of £383,470,000.

Of Canadian banks there are eight with 2,653 branches, £16,524,000 capital and reserves; £28,047,000 deposits, and total assets £44,571,000, which would seem to be the position that business

lacking the British Empire in central banks, it certainly does not lack branch banks for the use of its nationals; what is needed is the coordination of the several systems. (W. F. S.)

II. UNITED STATES. Subsequently to the panic of 1907 and the recovery which followed, the banking system of the United States entered upon a period of prosperity and success which continued practically unbroken to the opening of the World War. The sudden outbreak of that war, 1914, caused a temporary shock not only to banking but to general business. This uncertainty, however, lasted but a few months, and was succeeded by a restoration of confidence which continued with expanding business and activity in all branches of banking down to the autumn of the year 1920. In the autumn of 1920 the development of post-war reaction in business and a violent shrinkage of prices brought severe pressure to bear upon all the elements of the banking system of the United States, but this was not sufficient to cause any dangerous shock. The period in question was one of unusual importance in American banking, not only because of the organization of the Federal Reserve system in which all national banks were compelled by law to assume membership, but also because of the fact that the strongest state banks and trust companies voluntarily entered the system during the first three years after its formation, with correspondingly broad effects upon financial organization, while the effects of the war and the expansion of American industry which accompanied the struggle greatly enlarged the activity of American banking and added to its profits.

*Pre-War Period.*—The years 1908-13 were characterized by a steady and consistent growth of business. In the following table, which shows the advance in the number of organized banks as well as their chief assets and liabilities, the increase of operations may be noted during the five years in question, and may be compared with the advance during the war period:—

necessity for the creation of national currency associations, since no disturbance in business conditions seemed to be imminent, the national banks made no effort to form them.

GROWTH OF NATIONAL BANKS BY FIVE-YEAR PERIODS  
(In thousands of dollars)

	No. of banks.	Total deposits.	Loans and discounts.	Reserve held.	Excess reserve.
Sept. 5 1900	3,871	3,699,804	2,686,760	983,333 <sup>2</sup>	299,208
Aug. 29 1905	5,757	5,508,643	3,998,509	1,294,298 <sup>2</sup>	322,170
Sept. 1 1910	7,173	7,140,836	5,467,161	1,573,522 <sup>2</sup>	313,475
Sept. 2 1915	7,613	9,229,316	6,756,680	1,969,398 <sup>2</sup>	868,766
Sept. 8 1920	8,093	16,751,956	13,706,066	1,232,039 <sup>2</sup>	38,092

	No. of banks.	Capital.	Surplus and undivided profits.	Circulation.	Total resources. <sup>4</sup>
Sept. 5 1900	3,871	630,299	389,469	283,949	5,048,138
Aug. 25 1905	5,757	799,870	620,294	468,680	7,472,351
Sept. 1 1910	7,173	1,027,735	874,038	674,822	9,826,181
Sept. 2 1915	7,613	1,068,864	1,022,506	718,496	12,267,090
Sept. 8 1920	8,093	1,248,271	1,456,067	693,270	21,885,480

<sup>1</sup> Includes rediscouts.

<sup>2</sup> Includes cash in vault and due from reserve agents.

<sup>3</sup> Cash in vault, \$842,609,000; due from Federal Reserve banks, \$315,409,000; due from approved reserve agents, \$811,380,000.

<sup>4</sup> Lawful reserve with Federal Reserve bank. In addition, national banks held \$471,546,000 cash in vault and \$1,917,438,000 due from other banks including items with Federal Reserve banks in process of collection.

During the years in question the National Monetary Commission, appointed in accordance with the provisions of the Aldrich-Vreeland law, was prosecuting its investigations into existing conditions, but these investigations were academic up to 1912, while even in the latter year the bill for banking reorganization proposed by the National Monetary Commission

PRINCIPAL ITEMS OF RESOURCES AND LIABILITIES OF NATIONAL, STATE, SAVINGS, PRIVATE BANKS, LOAN AND TRUST COMPANIES FROM 1900 TO 1920. Compiled from reports obtained by the Comptroller of the Currency. (In millions of dollars)

	Banks.	Resources.					Liabilities.						
		Loans and Dis-counts.	Invest-ments.	Due from Banks.	Cash on Hand.	Aggregate Resources.	Capital Stock Paid in.	Surplus Fund.	Undivided Profits, Less Ex-penses.	Due to Banks.	Individu-al Depos-its.	United States Depos-its.	Nation-al Bank Circulation.
1900	10,382	5,625	2,498	1,272	740	10,788	1,024	648	231	1,172	7,239	98	265
1901	11,406	6,387	2,821	1,448	807	12,457	1,076	687	268	1,333	8,460	99	319
1902	12,424	7,145	3,039	1,561	848	13,383	1,201	781	315	1,393	9,104	124	309
1903	13,684	7,688	3,490	1,770	857	14,303	1,321	903	369	1,476	9,553	147	359
1904	14,850	7,930	3,954	1,842	990	15,198	1,392	993	367	1,452	10,000	116	399
1905	16,410	8,971	3,987	1,982	994	16,918	1,463	1,053	385	1,904	11,350	75	445
1906	17,995	9,827	4,073	2,029	1,016	18,147	1,565	1,180	378	1,899	12,215	89	510
1907	19,746	10,697	4,377	2,135	1,113	19,645	1,690	1,305	339	2,075	13,099	180	547
1908	21,346	10,380	4,445	2,236	1,368	19,583	1,757	1,401	359	2,198	12,784	130	613
1909	22,491	11,303	4,614	2,562	1,432	21,095	1,800	1,326	508	2,284	14,035	70	636
1910	23,095	12,495	4,723	2,393	1,423	22,450	1,879	1,547	404	2,425	15,283	54	675
1911	24,392	12,982	5,051	2,788	1,554	23,631	1,952	1,512	553	2,621	15,906	48	681
1912	25,195	13,892	5,358	2,848	1,572	24,986	2,010	1,585	581	2,632	17,024	58	708
1913	25,993	14,568	5,407	2,776	1,560	25,712	2,096	1,676	573	2,584	17,475	49	722
1914	26,765	15,288	5,384	2,872	1,639	26,971	2,132	1,714	562	2,705	18,517	66	722
1915	27,062	15,722	5,881	3,283	1,457	27,804	2,162	1,732	639	2,783	19,135	49	722
1916	27,513	17,811	6,796	4,032	1,486	32,271	2,195	1,849	564	3,463	22,834	39	676
1917	27,923	20,594	8,003	4,793	1,502	37,126	2,274	1,945	674	3,913	26,289	133	660
1918	28,880	22,514	9,741	5,136	896	40,726	2,351	2,034	684	3,895	27,808	1,037	681
1919	29,123	25,301	12,229	5,865	997	47,615	2,437	2,182	825	3,890	33,065	566	677
1920	30,139	31,256	11,387	5,833	1,076	53,079	2,702	2,410	976	3,708	37,683	175	688

In order to show the relative position occupied by the national banks, the following tabular comparison, relating to national institutions only, is presented. It will be understood that while the state banks and trust companies included in their number the bulk of the investment institutions of the nation, the commercial banking assets were predominantly held by the national banks.

The period 1908-13 was not, however, notable for any far-reaching changes in method or organization; provisions which had been enacted in the Aldrich-Vreeland law of May 30 1908 for the formation of national currency associations (see FEDERAL RESERVE BANKING SYSTEM) remaining practically a dead letter. There being no immediate or urgent

(the "Aldrich Bill") had small chance of success so that at no time prior to 1913 was there a serious prospect of fundamental change in legislation. The adoption of the Federal Reserve Act in the latter year greatly altered the conditions under which the national banking system, and indeed the whole banking system of the United States, was operating, but it did not produce any direct or immediate effect upon the methods or position of the banks themselves until a much later date. Indeed, the Federal Reserve Act itself did not come into practical operation until nearly a year subsequently to its passage, the reserve banks being organized in Nov. 1914. During the pre-war years, however, the problems of the national banking system which had already been recognized had been growing more and

more obvious. Prominent among these was the insufficiency of the note currency, which continued to be issued solely upon the security of national bonds. In the accompanying table the note issues of the national banks during the years in question may be traced:—

YEARLY INCREASE OR DECREASE IN NATIONAL BANK CIRCULATION FROM 1900 TO 1920

	Issued	Retired	Increase	Decrease
1900	\$101,645,393	\$16,537,068	\$85,108,325	
1901	123,100,200	15,951,527	107,148,673	
1902	12,620,682	21,868,006	29,752,676	
1903	68,177,467	28,474,958	39,702,509	
1904	69,532,176	31,939,760	37,601,393	
1905	90,753,284	22,732,060	68,021,224	
1906	84,085,200	25,055,739	59,029,521	
1907	56,303,658	27,980,139	28,323,519	
1908	141,273,164	80,025,078	61,248,086	
1909	82,504,444	48,433,296	34,071,148	
1910	57,101,345	33,011,051	24,090,330	
1911	49,896,951	35,284,247	14,612,704	
1912	38,747,149	27,586,734	11,160,415	
1913	37,210,597	26,441,867	10,768,730	
1914	387,763,860	20,246,418	367,517,442	
1915	27,485,675	342,807,533		\$315,322,858
1916	10,593,700	59,026,803		48,433,103
1917	22,749,150	37,211,370		14,462,220
1918	26,227,740	18,781,552	8,431,700	985,512
1919	29,660,850	24,864,635	4,796,215	
1920	29,000,000	20,000,000	9,000,000	

NATIONAL BANK NOTES OUTSTANDING OCT. 31 1920

Denomination	Amount
One dollar	\$ 341,906
Two dollars	103,288
Five dollars	125,659,460
Ten dollars	305,429,590
Twenty dollars	243,445,080
Fifty dollars	29,862,000
One hundred dollars	39,542,700
Five hundred dollars	87,500
One thousand dollars	21,000
Fractional parts	59,800
Total	\$735,612,324
Less <sup>1</sup>	3,062,695
Total	\$732,549,629

<sup>1</sup> Notes redeemed but not assorted by denominations.

The figures show a practically stationary condition of the circulation. They cannot, however, throw light upon the increasing volume of demand for currency, which during those years was growing at a rapid rate. Only through an enlarged use of cheques and other credit substitutes or through additions to the basic monetary circulation itself was it possible for the United States to add to its circulating medium. Another factor which had assumed very great importance during the preliminary period referred to, was the growth of trust companies, involving as it did sharp competition with national banks. Subsequently to the year 1890 there had been a rapid development of trust companies in many parts of the United States as well as extension and improvement of legislation affecting them. In some states the trust companies, either through local restriction or as the result of custom, still confined themselves to fiduciary business, but under the laws of most commonwealths they had taken on banking functions, and in some they had developed the latter with so much success as to make their preliminary or nominal purposes largely secondary. Due to the fact that trust company laws were usually much less restrictive than those which controlled the operation either of national banks or of state banks, both of the latter classes of institutions were feeling the competition of the trust companies with considerable severity. The table on the next page shows the relative positions of different classes of banks in 1920 and the increase in the number of trust companies and savings banks during recent years.

Savings banks' development during this period is shown in the following figures:—

Year	Banks	Depositors	Deposits
1900	1,002	6,107,083	\$2,449,547,885
1901	1,007	6,358,723	2,597,094,580
1902	1,036	6,666,672	2,750,177,290
1903	1,078	7,035,228	2,935,204,845
1904	1,157	7,305,443	3,060,178,611
1905	1,237	7,696,229	3,261,236,119
1906	1,319	8,027,192	3,482,137,198
1907	1,415	8,588,811	3,690,078,945
1908	1,453	8,705,848	3,660,553,945
1909	1,703	8,831,863	3,713,405,710
1910	1,759	9,142,908	4,070,486,246
1911	1,884	9,794,647	4,212,583,598
1912	1,922	10,010,304	4,451,818,522
1913	1,978	10,766,936	4,727,403,950
1914 <sup>1</sup>	2,100	11,109,499	4,936,591,849
1915	2,159	11,285,755	4,997,706,013
1916	622	8,592,271	4,186,976,600
	1,247	2,556,121	901,616,694
1917	622	8,935,055	4,422,489,284
	1,185	2,431,958	995,532,890
1918	625	9,011,464	4,422,096,393
	1,194	2,368,089	1,049,483,555
1919	622	8,948,808	4,751,113,000 <sup>2</sup>
	1,087	2,486,073	1,151,464,000 <sup>2</sup>
1920	620	9,445,327	5,186,845,000 <sup>2</sup>
	1,087	1,982,229	1,339,625,000 <sup>2</sup>

<sup>1</sup> In the assembling of data in relation to savings banks the classification of banks as made by the State banking departments is closely followed, in consequence of which a number of so-called State savings banks, formerly treated by the Comptroller's office as savings banks, are now regarded as commercial banks, and the returns therefrom are combined with the latter, which accounts for the relatively small amount of deposits reported for stock savings banks since 1915.

<sup>2</sup> Dividends unpaid not included.

The number of trust companies and information with reference to the principal items of assets and liabilities on or about June 30 of each year since 1914 are shown in the following table:—

	Number	(In millions of dollars.)					
		Loans <sup>*</sup>	Investments	Capital	Surplus & Profits	All Deposits	Aggregate Resources
1914	1,564	2,905.7	1,261.3	462.2	564.4	4,289.1	5,489.5
1915	1,664	3,048.6	1,349.6	476.8	577.4	4,604.0	5,873.1
1916	1,606	3,704.3	1,605.4	475.8	605.5	5,732.4	7,028.2
1917	1,608	4,311.7	1,789.7	505.5	641.8	6,413.1	7,899.8
1918	1,669	4,403.8	2,116.6	525.2	646.9	6,493.3	8,317.4
1919	1,377	4,091.0	2,069.9	450.4	588.6	6,157.2	7,959.9
1920	1,408	4,601.5	1,902.1	475.7	612.1	6,518.0	8,320.0

<sup>\*</sup> Includes overdrafts.

While commercial banks, both national and state, had from time to time considered the question of seeking permission to exercise fiduciary functions, the problem had never assumed any considerable importance until the Federal Reserve Act was brought up for consideration. Their policy had been directed towards enforcing a limitation or restriction of the banking functions of trust companies, both in the states where local legislation had not made much direct concession to trust company activity, and in those where a beginning had already been made in extending to them banking powers, rather than to competing with them. One demand which had been made with entire justice by the national banks had been that in so far as they exercised actual banking functions and became liable for demand deposits, the trust companies should be required to keep a proportion of reserve equal to that required of the banks with which they were competing. Something had been done in the direction of applying such a requirement, but state laws were still in an unsatisfactory condition.

The Opening of the World War.—The year 1914 had opened prosperously for the banks of the country, business being practically normal and employment at least up to the average, while agricultural conditions were satisfactory. The sudden advent of war in Europe at the end of July, however, necessarily subjected the banks to a very severe shock. Due to the seasonal character of American exportations of agricultural products



**RESOURCES AND LIABILITIES OF 22,109 STATE, SAVINGS, AND PRIVATE BANKS AND LOAN & TRUST COMPANIES, JUNE 30, 1920**  
(In thousands of dollars.)

RESOURCES	18,195 State Banks.	620 Mutual Savings Banks.	1,087 Stock Savings Banks.	1,408 Loan and Trust Companies.	799 Private Banks.	Total 22,109 Banks.
Loans and discounts (including overdrafts)	8,963,410	2,591,480	978,483	4,601,588	128,915	17,263,796
Investments (bonds, securities, etc.)	2,226,916	2,716,282	323,596	1,902,975	32,191	7,201,060
Banking House, furniture and fixtures	262,042	41,599	32,277	163,233	4,016	503,197
Other Real Estate owned	42,961	9,980	5,555	26,689	7,720	92,823
Due from Banks	1,549,571	183,527	70,783	878,692	29,467	2,712,040
Cheques and other cash items (including ex- changes for clearing-house)	332,848	1,791	4,836	193,615	1,463	533,952
Cash on hand	393,935	41,942	35,215	148,455	6,480	626,027
All other Resources	238,098	33,016	55,668	405,831	2,344	734,958
<b>Total Resources</b>	<b>14,009,781</b>	<b>5,619,017</b>	<b>1,506,413</b>	<b>8,320,018</b>	<b>212,626</b>	<b>29,667,855</b>
<b>LIABILITIES</b>						
Capital Stock paid in	920,211		69,183	475,745	13,334	1,478,473
Surplus Fund	527,019	334,546	39,422	509,929	13,046	1,423,962
Undivided Profits	222,599	87,973	13,247	102,194	3,458	429,473
Due to Banks	436,644	116	841	424,542	2,139	864,282
Dividends unpaid	9,126	126	38	4,095	101	13,485
Individual Deposits	10,873,035	5,186,845	1,349,625	6,085,675	169,573	23,664,753
Postal Savings Deposits	10,705	1	1,726	3,673	28	16,133
Notes and Bills rediscounted	136,365	144	52	146,546	1,639	284,746
Bills payable	549,608	395	24,029	214,144	5,870	794,046
Other Liabilities	324,452	8,869	8,250	352,475	3,438	698,501
<b>Total Liabilities</b>	<b>14,009,781</b>	<b>5,619,017</b>	<b>1,506,413</b>	<b>8,320,018</b>	<b>212,626</b>	<b>29,667,855</b>

and of many of the importations of manufactures, it had become customary in past years for English banks to hold claims upon American institutions which gradually accumulated each year up to the opening of the autumn season, when the movement of crops to foreign countries provided funds which were used for the cancellation of these balances. At the opening of the war it was supposed that in trade with England such balances against American banks amounted to something like \$500,000,000. One phase of Great Britain's economic policy upon the outbreak of war was to call in the balances due to her in foreign countries and generally to cut off trade relations that might subject her credit structure to fresh demands. At the same time the presence of German war-vessels in the Atlantic made it uncertain how long a time must elapse before the movement of goods to and from Europe would be resumed upon a normal basis. The export trade of the United States was thus seriously checked at the same time that extensions of credit by British banks were practically suspended. One immediate effect of this situation was to cause a large exportation of gold from the United States, while the shipment of goods was first reduced, and at last temporarily suspended. These two factors caused serious disturbances in the eastern part of the country and produced a general lack of confidence, while at the same time they tended to depress the prices of American staples. Cotton was affected with particular seriousness, its price declining during the autumn to a point as low as five cents per pound as against a figure, then regarded as normal or satisfactory, of 12 or 13 cents in the early part of the year. In consequence of this stagnation of export trade, there was a somewhat corresponding shock to domestic business, a resulting difficulty in making collections, and eventually a withdrawal of funds from banks not only for export of specie, but also for the purpose of domestic hoarding. Congress, which was then in session, hastened to amend the Aldrich-Vreeland Act of 1908, the measure thus adopted taking effect on Aug. 4 1914. Under the terms of this amendatory measure the issue of emergency currency was permitted under more liberal conditions than before. It would have been much better if the Federal Reserve Act, which was passed during the preceding Dec., had been brought into operation, but as a matter of fact reserve banks did not get under way until Nov. 1914. The action of Congress in passing the emergency currency law was, therefore, necessary in order to provide an immediate means of furnishing funds for the payment of depositors. The currency thus provided for under the new law was accordingly issued and eventually rose to a peak point of about \$430,000,000. This served to take the place of gold which was then moving out of the country,

the total gold exports during 1914 amounting to approximately \$223,000,000. Meanwhile the Federal Reserve Board had been organized in accordance with the terms of the Federal Reserve Act on Aug. 10 1914, and was immediately confronted by the great losses of gold which were being incurred by the banks in order to satisfy the demands of British creditors. In the belief that much of this withdrawal of gold was due to a lack of combined action on the part of the American banks, the board supervised the formation of what became known as the "international exchange fund," or "gold pool," which was in effect an agreement among American banks to provide a total of \$100,000,000 of gold for export (or gold exchange), permitting any bank that might be drawn upon to supply itself from the common stock by depositing therein satisfactory funds in other forms. This measure was effective in restoring confidence while at the same time the first fear and uncertainty that had resulted from war conditions began rapidly to disappear; German vessels were soon driven from the North Atlantic and the movement of products from the United States to Europe was resumed upon a limited scale. The urgency of demands for cash declined and the banks (which had begun the issue of clearing-house certificates on Aug. 3) were able to retire their obligations on Dec. 1, although the Stock Exchange (which had been closed on July 31) was not reopened until later. Thus the banks of the country passed through the dangerous early stages of the war partly by exercising their own latent power and partly in consequence of the aid which had been extended to them through Congressional enactment and through cooperative effort under the leadership of the Federal Reserve Board.

*The Banks and the Federal Reserve System.*—The projected text of the Federal Reserve Act had been made public in June 1913, and had served as a basis for discussion from that date up to the passage of the Act on Dec. 23 of the same year. It may fairly be said that practically all of the banks of the country were opposed to it—the national banks primarily because it made membership in the system compulsory; the other banks, because they feared that great changes and innovations in business would result from the new system. After the adoption of the Federal Reserve Act the question whether or not to enter the system became acute with national banks since the law had provided that a failure of any national bank to enter the system would mean the necessity of surrendering its charter and transferring itself to a state banking system, through reincorporation. Accordingly during the early part of the year 1914 there was constant discussion of the wisdom or the unwisdom of declining to accept membership. The result was a



practically unanimous determination to take stock in the new Federal Reserve banks. The principal points at which the new Act immediately touched the national banks were in connexion with the contribution of capital and the transfer of their reserves. In the course of the discussion of the Federal Reserve Act there had been an effort on the part of the national banks (especially after membership in the system had been made compulsory) to reduce the required amount of contribution to the capital stock of the Federal Reserve banks to as low a level as possible. It was eventually fixed at 3% of the capital and surplus of each national bank, so that when the banks eventually entered the system (as all except some eight or ten finally did) they were obliged to pay in only about \$50,000,000. In the same way they had endeavoured to avoid the necessity of transferring any part of their reserves to the Federal Reserve banks, except as they might elect, but had not entirely succeeded, although a three-year period was finally provided during which the transfers might be made in instalments, and only part of the reserves was even eventually to be transferred. At the outset the banks paid over to the Federal Reserve banks only about \$18,000,000 of capital and \$227,000,000 of reserve deposits. These payments were made during the month of Nov. 1914 and, as just shown, were only about \$245,000,000 in all, so that the burden of establishing the reserve system was not a particularly heavy one. Indeed, with the reduction in reserve requirements which had been made in the Federal Reserve Act (central reserve city banks being cut from 25% of reserve deposits to 18%, reserve city banks from 25% to 15% and country banks from 15% to 12%), the banks were in much better condition to take care of the needs of their customers than they were before the organization of the reserve system, even without any recourse to re-discounting. In view of the fact that European demands for American goods were considerably reduced during the first months of the war, so that industry was temporarily checked and domestic prices were lowered, bank resources were more than adequate to the needs of customers. Later as the requirements of European countries became heavier and export shipments from the United States were increased, the banks entered upon a period of unusual prosperity, and the difficulty in earning dividends which they had experienced during 1915 disappeared. Credit in fact became comparatively safe, not only on account of the rapidly rising prices which greatly reduced the danger of business failure, but also because of the fact that many of the large purchases of goods in the United States made for European account were practically guaranteed by foreign Governments which at that time were in a relatively strong financial condition. The number of banks accordingly increased steadily and the capital and surplus even more markedly, as may be seen from the tables already given. What has been said in this section is intended to apply directly to the case of the national banks but holds equally true of state institutions (both banks and trust companies). All went through a somewhat parallel course of development, while the high wages and steady employment which were due to very large European purchases of goods provided a strong basis for the growth of savings. Savings deposits accordingly advanced decidedly in amount. For the same reason which enabled national banks to refrain from re-discounting, state banks and trust companies were relieved of any urgent necessity to enter the Federal Reserve system. The system accordingly extended but little credit to its members up to the end of 1916, while it enlarged its membership very little outside of the national banks themselves.

*The War Period.*—An entirely different situation came into existence immediately upon the entry of the United States into the World War in April 1917. There had already been some growth of re-discounting during the earlier months of that year, and Congress after the opening of the war, June 1917, amended the Federal Reserve Act. By the terms of this new law all reserves of national banks were to be carried in Federal Reserve banks and nothing held in vault was to be counted as reserves, it being felt that such action was practically essential

in order to concentrate the banking power of the country, to enlarge the lending power of the reserve banks and to relieve the members of the necessity of carrying coin in vault. At the same time effort was made to discourage the payment of coin or legal-tender money to depositors, so that the banks soon passed to what was really a paper basis. The continued importations of gold strengthened the reserve bank holdings, so that there was at all times far more gold in the country than before the war. The net increase in gold holdings was fully \$1,000,000,000, but gold coin had practically disappeared from common use. Congress had also provided, in the Act already referred to, for membership of state banks in the Federal system under conditions which permitted them to withdraw whenever so disposed by giving six months' notice. Partly because of this assurance of ability to retire and partly because of a feeling that the advent of war would naturally subject all banks to severe stress, while at the same time it was regarded as a matter of patriotism to render such aid to the Government as they could, a large number of institutions entered the system. These accretions to membership continued rapidly during the years 1917-8 and resulted eventually in the admission of about 1,200 state institutions. The movement into the system had a rather important effect upon the banks and trust companies that joined. They were compelled as a condition of membership to maintain reserves equal to those of the member banks already in the system, so that a process of standardizing reserves was effectively carried forward. During the years 1915-8 there had been extensive changes in state banking legislation. These changes had provided more nearly uniform reserve requirements, besides authorizing the local state banks to become members of the reserve institutions if they felt so disposed. In consequence even those banks which did not become members were in some measure adjusted to the banking situation by being subjected to more uniform requirements. A somewhat similar process was also going on in the matter of types of bank paper, the new legislation both of Congress and of the states being intended to standardize these types. Thus the United States emerged from the war with a much more harmonious and uniform system of banking legislation than it had ever before possessed.

*Change in Holdings.*—The effect of the war was, however, of a very far-reaching character in its relation to the portfolios or paper holdings of the banks of the country. The method of financing the war which was chiefly resorted to by the Treasury involved heavy taxation, but it was some time before the new taxes could yield any returns and the Federal Government never obtained from that source more than about one-third of its total outlay. The other two-thirds were obtained from the banks and the public by borrowing. The public was encouraged to save and to use its savings in the purchase of Liberty Bonds, but a very large proportion of the bonds sold to the public had to be carried in part at least by means of loans obtained at banks upon paper collateralized by Government obligations. This was true of all classes of banks, both national and state, as well as of the trust companies, while the latter and the savings banks were also urged to purchase and hold as many Liberty Bonds as they could. In these ways the investments of the banks and their commercial portfolios came to consist very largely of paper collateralized by Government obligations. This was true not only of the paper which represented subscriptions to bonds, but also of paper which took the place of ordinary commercial borrowings. Due to the fact that many business men preferred to borrow on their own notes collateralized by Government bonds in order to get the lower rates of interest made by the banks on such notes, paper of this kind rapidly displaced ordinary evidences of indebtedness. This state of things continued until some time after the close of the war, a modification occurring in the autumn of 1919 and continuing to grow more pronounced thereafter.

*New Functions of National Banks.*—Prior to the adoption of the Federal Reserve Act national banks had not been allowed to perform so-called fiduciary functions, including those of acting

as guardian or trustee, registrar, fiscal agent, administrator and others. These functions had been exclusively performed by trust companies, most states following the example of the National Bank Act and drawing a sharp line of distinction between their own state banks and their trust companies. The Federal Reserve Act authorized the assumption of fiduciary powers by national banks upon permission of the Federal Reserve Board. Such permission when granted by the Board was promptly questioned in the courts, but was upheld by the Supreme Court of the United States. This decision led to an extension of the scope of the fiduciary functions so that national banks were shortly placed upon a basis of competitive equality with trust companies. The situation led various states to modify their laws in such a way as to permit state banks to take on fiduciary functions likewise. Thus the distinction which had previously existed between national banks, commercial state banks, and trust companies was gradually wiped out. By the end of 1920 about 1,200 national banks had been granted permission to exercise trust functions. The time has not yet been sufficiently long to permit an accurate judgment of the effect of these changes upon the general banking situation, the full exercise of fiduciary functions being usually a process of comparatively slow development.

*Organizing for Foreign Trade.*—One of the principal defects of the old national banking system was that it did not function well in connexion with foreign trade. Neither national nor state banks had been in the habit of using bankers' acceptances, which had become the standard basis of foreign business in Great Britain. This defect was remedied in the Federal Reserve Act, which authorized the making of acceptances by national banks up to an amount equal to 100% of the capital and surplus of the accepting bank (50% in the original Act confined to foreign trade, but later amended to 100% of which not to exceed 50% might be domestic acceptances). Several of the states in which banking had assumed the greatest development made a similar change in their legislation at about the same time, so that at the opening of the World War, with its great impetus to American foreign trade, the banking system, both national and state, was in position to finance business on the acceptance plan. It was seen, however, in the formulation of the Federal Reserve Act that in order to develop foreign banking successfully the use of the branch system would be necessary. Branch banking had never been permitted in the United States under the National Bank Act, and although it sporadically existed under various state laws such systems were only local and not particularly successful. It may broadly be said, therefore, that there had been no development of the branch bank principle prior to 1913. Although at one time it was proposed to insert in the Federal Reserve Act permission to establish domestic branches of national banks, and although the Act gave to Federal Reserve banks power to establish branches within their own districts and at their own discretion, it withheld from national banks power to create domestic branches. It, however, did vest them under certain conditions with the power to establish branches abroad. This power was used by only one or two of the larger national banks, and early in 1915 the demand for action which would allow national banks to subscribe to the stock of foreign trade banks to be jointly owned by them became very strong. Accordingly Congress in 1915 modified the Federal Reserve Act to the extent of permitting the organization of foreign trade banks. The plan, however, did not meet with much favour and few such banks were organized. Those which were brought into existence did a fairly successful business, but not enough were established to give the plan a commanding place in American financial life. The subject, however, of financing foreign trade was unavoidably thrown into the background by the advent of the war and the conditions growing out of it. Foreign countries financed their purchases of American goods upon what was practically a cash basis prior to the time that the United States itself entered the war, and after that date practically the whole export trade of the United States was financed upon the basis of Government credits for

which the U.S. Treasury furnished the means. The result was to make the whole foreign banking question far less urgent or immediate than it would otherwise have been. Not until the war had closed, and indeed, not for some considerable time after, did the subject receive discussion. Such discussion, however, became general about the middle of 1919, and at that time it seemed to the Federal Reserve Board that a plan of action modelled upon the British investment trust might serve as a basis for the general long-term financing of American exports. This export financing was regarded as essentially a problem which involved the shipment of goods upon long-term credit, it being recognized that much time must elapse before foreign countries could send to the United States enough goods to keep their American trade in current balance. Accordingly the so-called Edge Act was passed Oct. 1919. It and the regulations subsequently issued by the Federal Reserve Board provided for the establishment of foreign trade financing corporations of two classes, the one vested with very large powers of acceptance and really differing in no essential way from the foreign trade banks already referred to, except that the stock of the Edge Act corporations might be held by individuals or commercial establishments and not exclusively by banks. The other type of corporation was to be organized for the purpose of providing credit in the export trade, the securities and evidences of indebtedness which it received being employed as a basis upon which debentures or bonds would be issued and offered to the public, thereby restoring to the corporation issuing them the funds which it required, for still further dealings and advances of the same kind. At first but little interest was shown in the idea of such corporations. Prior to the close of 1920 only one had been actually organized although several were under consideration, and early in 1921 the formation of two additional enterprises of the same sort was announced. The most important of the early undertakings under the Edge enactment was a corporation projected by the committee representing the American Bankers' Association, whose capital was to be \$100,000,000 and whose stock was offered to the public early in the year 1921. The Edge Act may be summarized in the statement that it was in effect a plan to provide for the financing of foreign trade apart from domestic banking operations, and with a very much greater latitude in respect to the granting of credit than could properly be allowed to domestic institutions.

*Growth of a Discount Market.*—The use of the acceptance function to which reference has already been made progressed comparatively slowly during the early years of the Federal Reserve system, being retarded by the various disturbing conditions attendant upon the war. The expansion of the acceptance proceeded most rapidly and reliably in connexion with foreign trade, where this type of paper speedily assumed a position of some importance. Its growth was, however, greatly restricted as a result of the lack of branch banks maintained by American institutions in foreign countries. At the close of 1920 it was estimated by the Federal Reserve Board that the total amount of acceptances made by member banks of the system and then outstanding was probably a little under \$650,000,000. The bulk of these acceptances had been made by a comparatively small number of acceptance-issuing institutions located for the most part at points whose interest carried them in considerable measure into the export trade. Some interior banks had attempted to develop the domestic acceptance, but with no great success, while the commercial, or trade, acceptance, or "domestic bill" as known in other countries, had shown but slight signs of assuming importance. This was partly due to the existence of the well-known system of offering cash discounts which, if it did not originate in the United States had attained by far its greatest development there. Under the cash discount system, while invoice prices were strictly maintained, a second or reduced invoice price was offered to those who were able to make an immediate or "cash" payment within a specified number of days from the date of the invoice, while to those who preferred to enjoy the full period of credit the full face value of the

merchandise was charged. It was clear that in these circumstances, with two rates of charge, the drawing of a merchandise bill at a fixed figure would have been difficult. Hence the very slow development of what was called the trade acceptance, and trade acceptances thus created tended to become in many cases long-term accommodation paper and fell somewhat into disrepute. In the case of the bankers' acceptance, although some bad practices prevailed during the war when the practice of renewing acceptances gained a foothold even with the best and strongest banks through the use of syndicate agreements which provided for the issuing and discounting of blocks of acceptances by groups of banks acting in common, the paper on the whole maintained its position of solvency and reliability. The chief trouble encountered in its development was early found in the fact that no genuine market existed for it and that the Federal Reserve banks had found it practically necessary to supply such a market by taking or re-discounting freely the acceptances of banks in their own district. Had they not done so, it appeared, the acceptances would have found no buyers on many occasions and the practice of making them and financing trade by that means would have been discontinued. This tended to transfer to the portfolios or holdings of the Federal Reserve banks an unduly large proportion of the acceptances at any time in the market, while the bad habit of some banks in discounting their own acceptances deprived the paper of much of its economic virtue as a basis for dealing in commercial credit under better market conditions. It had still in 1921 to be seen how far and to what extent it would be possible to overcome these bad elements in American banking practice and to resume the development of the acceptance upon the lines followed in the more advanced commercial countries of Europe.

**History of Interest Rates.**—After the panic of 1907 and throughout the whole pre-war period rates of interest on bank loans tended on the whole to move in the United States steadily to lower levels. A variety of reasons had been assigned for this drift, among them the rapid accumulation of capital and the intensity of the competition in the investment market. As had been the case with the American market throughout its whole history, the movement of interest and discount rates was by no means uniform, call loans on many occasions shooting up above the general level, while even commercial paper and bank rates tended to fluctuate sharply at different seasons. The tendency, however, was on the whole downward, and after the financial disorders attendant upon the opening of the World War had subsided and the new reserve banks had become thoroughly organized interest and discount rates fell to an extremely low level. This was partly the outcome of the release of credit by the Federal Reserve Act, and partly the result of scarcity of business due to the opening of the war and the transition it implied from a peace to a war basis. Low rates continued to prevail practically throughout the years 1914-6, indeed, until the entry of the United States into the war in 1917. The natural tendency of interest rates would have been to advance immediately after the participation of the United States in the war had become known. Recognizing this tendency, however, the Federal Reserve banks had in conjunction with the United States Treasury determined upon a low rate of discount for paper at Federal Reserve institutions, such rate corresponding closely to the coupon rate upon Liberty Bonds. This rate, however, was put into effect upon the condition that a correspondingly low rate should be made by member banks to their customers. Thus the whole interest rate system of the country was "stabilized" or "price-fixed." In ordinary conditions this stabilization at a low figure would have given rise to an abnormal demand for funds, but this danger was in part averted through the control of industrial operations by the "rationing" of coal and materials for industries, which kept producers from drawing too heavily upon bank credit for support. In some cities, notably New York, a majority of the banks rationed in a similar way the stockbroking and speculative community, agreeing to furnish them with a limited amount of funds at a specified and relatively low rate of interest on condition that there should be no effort to use more than this specified amount in stock speculation and that a correspondingly low rate of interest should be charged to customers. Capital was also rationed by the use of analogous methods. Subject to these conditions the rate of interest continued on an abnormally low level until after the war when, as seen in another connexion (see FEDERAL RESERVE BANKING SYSTEM), the rate of discount at the Federal Reserve banks was sharply advanced. Commercial rates, which had already been on the point of rising in some directions, advanced immediately. The action of the Federal Reserve banks was the signal for a still further and subsequent advance in rates, and from the opening of 1919 on throughout the year 1920 there was a fairly steady advance in discount charges which brought the current charge for bank loans at

the close of 1920 up to the highest point it had reached for many years. Call loan rates, although fluctuating to some extent subsequent to the war, did not suffer the extreme variations which had been characteristic in other periods of stress. (H. P. W.)

**Savings Banks.**—According to the report of the comptroller of the currency for the fiscal year ending June 30 1920, there were in the United States 620 mutual savings banks with aggregate assets amounting to \$5,619,017,000; there were 9,445,327 depositors with combined deposits of \$5,186,845,000, an average of \$549.14 for each depositor. On the same date the number of stock savings banks was 1,087, with aggregate assets of \$1,506,413,000; there were 1,982,799 depositors with combined deposits of \$1,349,625,000, an average of \$680.86 for each depositor. These figures exclude stock savings banks of those states in which they were included with state bank returns: namely, Georgia; Kansas, Louisiana, Maryland, Michigan, Minnesota, Mississippi, Nebraska, and North Dakota. In the following table, for the years 1910 to 1919 inclusive, the figures are for mutual and stock savings banks combined:—

	No. of Banks.	No. of Depositors.	Deposits.	Average per Depositor.
1910	1,759	9,142,908	\$4,070,486,246	\$445.20
1911	1,884	9,794,647	4,212,583,598	430.09
1912	1,922	10,010,304	4,451,818,522	444.72
1913	1,978	10,766,396	4,727,403,951	439.07
1914	2,110	11,109,499	4,936,591,849	444.03
1915	2,259	11,285,755	4,997,706,013	442.83
1916	1,864	11,148,372	5,088,587,294	446.58
1917	1,807	11,367,013	5,418,022,775	472.15
1918	1,819	11,379,553	5,471,589,048	466.04
1919	1,719	11,434,881	5,902,577,000	516.19

The establishment of postal savings banks was authorized by Act of Congress, approved June 25 1910. On Jan. 3 1911 depositories for experiment were opened in each of the 48 states and territories. At the close of the month deposits amounted to \$60,252 and by the end of the year \$1,000,000. The original plan was gradually to designate as depositories all post-offices doing a money-order business, but it soon became apparent that many small offices would not be utilized. In 1913 the number of depositories had reached 13,000, when a policy of retrenchment was adopted. At the close of the fiscal year June 30 1920 there were 6,314 depositories. Deposits made during that year amounted to \$11,942,496; withdrawals \$12,802,207; balance credited to depositors \$157,276,322; number of depositors 908,508; average per depositor \$309.29. On June 30 1919 there were 6,439 depositories with deposits totalling \$167,323,260; the number of depositors 565,509 with an average deposit of \$295.88. The majority of depositors are of foreign extraction and their deposits constituted in 1920 75% of the total. The original law allowed a depositor to have to his credit a maximum sum of \$500; on May 18 1916 this was increased to \$1,000; and on July 2 1918 to \$2,500. Any person ten years old or over may make deposits. The minimum deposit is \$1; but a postal savings card may be purchased for ten cents, containing nine spaces for affixing postal savings stamps, costing ten cents each, and a card when filled is accepted as a deposit of \$1. The rate of interest is 2% annually, but deposits may be exchanged for postal savings bonds, issued in denominations of \$20, \$50, and \$500, bearing interest at 2%. As savings banks pay regularly 3% or 4%, and in some cases 5%, the postmaster-general, in his report for 1920, recommended an increase in interest on postal savings. According to the preliminary figures (Aug. 1 1921) on school savings, compiled by the American Bankers Association, covering the school year 1920-1, 236 cities reported school savings banks. There were 2,630 reporting schools; enrollment, 1,479,567; pupils participating, 666,478; average weekly deposits, \$205,704; total collections for the year, \$3,475,868; average saving per depositor, \$5.22; withdrawals during the year, \$1,393,230; average net deposit, \$3.13.

**BANTOCK, GRANVILLE** (1868— ), English musical composer, born in London Aug. 7 1868, was intended for the Indian civil service and later for the career of a chemical engineer, but abandoned both for music; he entered the Royal Academy of Music in 1889. There he gained many prizes and was the first holder of the Macfarren scholarship. In 1893 he founded the *New Quarterly Musical Review*, a pioneer publication on modern lines, and during the following two years he toured America and Australia as conductor of a Gaiety company, after which, in 1897 he became musical director at the Tower, New Brighton. Three years subsequently he was elected director of the school of music at the Midland Institute, Birmingham, and in 1908 he succeeded Elgar as professor of music at Birmingham University. A prolific composer in nearly all forms, among his best known works are *The Great God Ran* (1903); *Omar Khayyam* (1906); *Pierrot of the Minute* (1908); the truly choral symphony *Atlantis in Calydon* (1912); *Fifine at the*

*Fair* (1912); and the fine Hebridean Symphony (1916) for the publication of which the Carnegie Trust made themselves responsible. His great choral symphonies, for instance, *Atlantia*, a colossal work for unaccompanied choirs, occupying about 45 minutes in performance, and its companion, *Vanity of Vanities* (1914), are remarkable examples of his work. Bantock was largely instrumental in establishing the Birmingham competition festivals in 1912 and in increasing their efficiency.

**BARCLAY, FLORENCE LOUISA** (1862-1921), English novelist, was born at Limsfield, Surrey, Dec. 2 1862, the daughter of the Rev. S. Charlesworth, rector of the parish, and niece of Maria Louisa Charlesworth, author of *Ministering Children*. On March 10 1881 she married the Rev. Charles Barclay, vicar of Little Amwell, Herts. Her first novel, *The Wheels of Time*, appeared in 1903, but she is best known by its successor, *The Rosary* (1909), which reached a circulation of close on a million copies and was translated into many languages. The combination of religious feeling and strong love interest which characterized most of her novels appealed to a very wide public, and she enjoyed for some years an immense popularity, the total circulation of her books exceeding 2,500,000. Later novels included *The Mistress of Shenstone* (1910), specially filmed in America; *The Following of the Star* (1911); *The Broken Halo* (1913); *In Hoc Vinca* (1915); *Returned Empty* (1920). She died at Limsfield March 10 1921.

**BARING, MAURICE** (1874- ), English diplomat and man of letters, fourth son of the Lord Revelstoke (see 3,401), was born in London April 27 1874. Educated at Eton and Trinity College, Cambridge, he entered the diplomatic service in 1898, but resigned in 1904. Taking to literature and journalism, he acted also at various times as a war correspondent for *The Times* and for the *Morning Post*; but he cultivated *belles lettres* for the most part, and his poems and essays soon gained high critical approval. During the World War he worked on the staff of the R.F.C. in France and also at home. In addition to various volumes of imaginative literature—poems, parodies and critical essays—he published several works on Russia, especially *The Russian People* (1911); *What I Saw in Russia* (1913); *The Main Springs of Russia* (1914), etc. In 1920 he also published *R.F.C.H.Q. 1914-18*, an account of his experiences in France.

**BARKER, SIR JOHN, 1ST BART.** (1840-1914), British merchant, was born at Loose, near Maidstone April 5 1840. He was the son of Joseph Barker, a brewer, and founded the firm of John Barker & Co., Ltd., linen-drappers of Kensington, having previously been associated with the fortunes of Whiteley's, Westbourne Grove. He entered the House of Commons for Maidstone in 1900 but was unseated on petition. From 1906-10 he represented Penryn and Falmouth. In 1908 he was created a baronet. He took great interest in agriculture and did a good deal for horse-breeding. He died at Bishop's Stortford Dec. 16 1914.

**BARNABY, SIR NATHANIEL** (1820-1915), British naval architect, was born at Chatham in 1820, his father being a member of a family of shipwrights who for several generations had served in the royal dockyards. He was entered as an apprentice to his father's trade at the age of 14, and in 1848 won an Admiralty scholarship to the Portsmouth school of naval engineering, where he obtained distinction. He was appointed a draughtsman in the royal dockyard at Woolwich (1852), passing later to the constructive department at the Admiralty and becoming its head in 1870. Two years later he was appointed Chief Naval Architect, a title changed in 1875 to Director of Naval Construction. His work in that capacity is described in 24,804-5. On his retirement in 1885 he was created K.C.B. He died at Lewisham June 15 1915.

He wrote the articles **NAVY** and **SHIPBUILDING** for the E.B. 9th ed., and published *Naval Development in the 19th Century* (1902) and other works on naval construction, as well as *Christmas 1892 in Connaught: a Study of the Irish Question* (1893), and a collection of lyrics, *Songs by the Way*.

**BARNARD, GEORGE GREY** (1863- ), American sculptor (see 3,410), finished the Pennsylvania State Capitol group in

1911, and the pediments of the New York Public Library in 1914. His bronze statue of Lincoln, heroic in size, was unveiled in Cincinnati in 1917, and was highly praised by many admirers of Lincoln (e.g. by Miss Tarbell, his biographer, and by Theodore Roosevelt), but was called a caricature by many art critics. Mr. Robert Lincoln, the hero's son, objected to the proposed setting-up of replicas in London and Paris, and the council of the National Academy of Design issued a formal protest. A replica was unveiled at Manchester, England, in 1919.

**BARNES, GEORGE NICOLL** (1850- ), British Labour politician, was born at Lochie, Scotland, Jan. 2 1859. For many years he worked as an engineer, and in 1892 was appointed assistant secretary of the Amalgamated Society of Engineers, becoming its general secretary in 1896. In 1903 he went with the Mosely educational commission to the United States. In 1895 he had unsuccessfully contested Rochdale, but in 1906 was elected as Labour member for the Blackfriars (now Gorbals) division of Glasgow, where he defeated Mr. Bonar Law. This seat he retained in the general elections of 1910 and 1918. On Mr. Lloyd George's accession to power in 1916, Mr. Barnes joined his ministry as Minister of Pensions, and the same year was sworn of the Privy Council, but in Aug. 1917 resigned his office in order to enter the War Cabinet as representative of Labour, succeeding Mr. Arthur Henderson. In 1918 when the Labour party left the Coalition Mr. Barnes continued in the Coalition Government as minister without portfolio. He attended the Peace Conference at Paris as a Labour representative, and afterwards attended the International Labour Conference at Washington. He resigned in Jan. 1920 from the Cabinet.

**BARNETT, JOHN FRANCIS** (1837-1916), English musical composer (see 3,414), died in London Nov. 24 1916.

**BARNETT, SAMUEL AUGUSTUS** (1844-1913), English divine and social reformer (see 3,414), died at Hove June 17 1913.

See *Life* by Mrs. Barnett (1919).

**BARR, AMELIA EDITH** (1831-1919), author, was born at Ulverston, Lancs., England, March 29 1831. She was educated at the Glasgow, Scotland, high school. She married Robert Barr in 1850 and four years later they emigrated to Texas. Here, in 1867, she lost her husband and three sons through yellow fever. In 1869 she removed with her three daughters to New York where she wrote for the *Christian Union* and other periodicals. She continued to write unceasingly until 86 years of age, publishing altogether some 75 novels. She died in New York City, March 10 1919.

Her works include the following: *Romance and Reality* (1872); *Jan Veder's Wife* (1885); *A Bow of Orange Ribbon* (1886); *A Border Shepherdess* (1887); *Remember the Alamo* (1891); *Prisoners of Conscience* (1897); *Master of His Fate* (1901); *The Reconstructed Marriage* (1910); *Playing with Fire* (1914); *Measure of a Man* (1915); *The Winning of Lucia* (1915); *Profit and Loss* (1916); *Joan* (1916); *And An Orkney Maid* (1917).

**BARR, ROBERT** (1850-1912), British novelist, was born at Glasgow Sept. 16 1850 and taken to Canada when four years old. He was educated at the Normal school, Toronto, and became headmaster of the public school of Windsor, Ont., until 1876, when he joined the editorial staff of the *Detroit Free Press*. He had an adventurous career as a journalist for five years, and in 1881 came to England. In 1892 he started the *Idler* together with Mr. Jerome K. Jerome. He published a number of novels and short stories, the best known being *The Mutable Many* (1897); *Countess Tekla* (1899) and *The Sword Maker* (1910). He died at Woldingham, Surrey, Oct. 21 1912.

**BARRACKS AND HUTMENTS, GREAT BRITAIN** (see 3,427). The earlier article brought the account of this branch of military administration up to about 1904. It showed the principles on which British barrack design was based (viz. on the "Barrack Synopsis" and Standard Plans) and the provision which had been authorized in such matters as the numbers in one room, provision of dining-rooms and baths and other sanitary services, in the British army at home and in India. It mentioned

that in 1904 an architectural branch had been formed at the War Office, under civil control, for new barracks and hospitals at home stations; while services of a minor nature at home, and all services abroad, were carried out as heretofore, under the Royal Engineers. It remains here to show, as a sequel, how the "steady and systematic progress" already indicated, prior to 1904, was continued in the following decade, until, in the period of the great World War, the civil branch ceased to exist. During that decade many new works were carried out, some of them by the new civilian architects, and others by military engineers. Broadly speaking, those carried out under the former administration were of a substantial and permanent type, while the latter constructed those of a less solid and less ornate character, applicable to the exigencies of locality.

It is necessary, however, first to mention one important development of administration which had reference to this among other subjects affecting the soldier's well-being. In 1906 a Medical Advisory Board was instituted, consisting not only of eminent military medical officers, but also of distinguished medical men in civil life, the very best expert opinion in England on sanitary questions of all sorts. With them was associated an engineer officer of high rank. To this Board was referred all designs for barracks and hospitals at home and in foreign stations other than India, and their authority on all questions affecting housing was necessary before schemes could be sanctioned. They selected or approved all sites for dwellings—whether for barracks, married men's quarters, or hospitals—and they were referred to in all alterations to the Synopsis or Standard Plans. During the war their functions were carried out by an Army Sanitary Committee, which, under the chairmanship of an officer of high rank, made frequent tours in the theatre of war and in all hutted/camps, etc., in Great Britain.

**Permanent Barracks.**—The principal permanent British barracks (using their term to distinguish the type from those of "light construction") which were built during the decade 1904-14, were those for one battalion of infantry and one regiment of cavalry, near Edinburgh, at Redford.

The plan of the barrack building forms three sides of a quadrangle, and the buildings are three stories high. The ground floors are occupied with recreation and games' rooms on a generous scale, a sergeants' mess, regimental offices and shops, and other accessories, while the upper floors are used for the men's dormitories, and are divided up so that each man has a cubicle to himself. The dining-rooms and cook-houses, etc., occupy the space in the interior of the quadrangle. The whole scheme was on a scale of generosity far beyond anything hitherto constructed. The fact that it was designed with freedom from the restrictions hitherto imposed by standardization was a potential advantage, for it is only by independent thought that progress can be attained in any appreciable degree in this or any other branch of scientific experiment. But the advantages gained by such treatment of design have to be weighed against the disadvantages, viz.—the extra expense for housing even one unit, amounting to about 80% over the last approved type, and the time taken to build, which was also proportionally greater. It is also doubtful whether the arrangement of having the dormitories available for night use only—as was the intention—is as satisfactory from the point of view of military administration as the system, which it had superseded, of having men living together in groups of 10 or 12 with the intimacies and comradeship thus entailed.

At the Redford barracks the officers' quarters are in a separate block, together with the men's the whole forming a handsome building, and the married men's quarters are also separate.

**Light-Construction Barracks.**—About 1906-7 proposals were made to the Army Council of a somewhat novel principle in constructional work. Hitherto it had been always accepted as an axiom in military buildings that the more substantial and permanent the construction, the better, on the ground that although the first cost might be greater than that of a temporary building, such as a wooden hut, the cost of repairs for the latter worked out at so much higher a figure and the life of the building was so much shorter, that it was true economy in the end to build as solidly as possible. The cost of repairs in a solid well-built barrack might be between 0.75 and 1.25% of the capital value, but that of huts might run to 3 or 4%. It was pointed out in 1907, however, that this was a fallacious argument to apply to buildings which were required for a service subject both to

frequent changes of policy and to changes of standard imposed by progress in science. Thus the Royal barracks in Dublin, which in the reign of Queen Anne were considered the finest in Europe, were in the reign of Queen Victoria still standing, solid and substantial, but the despair of every sanitary expert. The same applies to many barracks (and, it may be added, to many civil hospitals) in many parts of the British Empire. It was argued, therefore, that constructional science had now reached a point where it was possible to build in a manner much less expensive, much more rapidly erected, and much more easily altered than the solid walls and heavy roofs of our fathers, and that such buildings, not much more expensive than temporary huts, could be made to suit military needs; and that the cost of maintenance would be no greater than that entailed in the case of more substantial works. Any one acquainted with the routine of military administration is familiar with the constant "reappropriations" that have to be made to suit some change in the requirements of accommodation. A row of married men's quarters has to be turned into a temporary, or even permanent, hospital, or a forage barn has to be made into a school, a gun-shed into a recreation room. With solid old masonry this became a serious and expensive matter. The whole subject required reconsideration.

Just then an opportunity occurred of making the experiment on a fairly wide scale. In the earthquake at Kingston, Jamaica, civil and military houses alike were shattered in a few seconds. The barracks, for about 800 men, with church, hospital and all administrative offices and staff quarters, had been of the old solid type. They were gone, and had to be replaced at once. Urgent representations to England pointed out that remedial measures must be instant, that there was neither material nor labour available locally, and that new plans should be proof against earthquakes and hurricanes.

It was decided at once to build the new barracks with a skeleton steel framework, vertical steel stanchions, braced below by steel horizontal joists, and above by a composite steel and wooden truss. The stanchions were rooted, as it were, by a broad flat plate, in a concrete block in the ground, and they were calculated to carry the whole weight of floors, walls, roof and any other contingent matters such as windows, doors, shelves, etc. The walls, which carried no weight, but were merely screens from weather, were composed of a double panelling of metal lathing plastered over and fastened to the steel stanchions. Being double, the space between the two sets of panels acted as a non-conductor of temperature. The whole of the work was quickly designed and the material quickly prepared. A firm of English contractors erected the skeleton of each building on their own premises, marked every part on a key plan, and the whole was dispatched from Bristol under charge of an experienced foreman of works, while a company of R. E. under a selected officer had meantime been dispatched, soon after the disaster, to erect the first building and arrange preliminaries for the others.

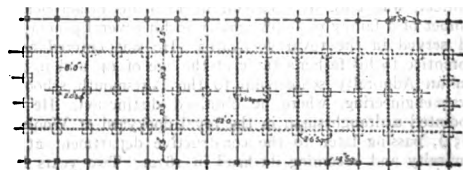

FIG. 1.

Figs. 1, 2, 3 and 4 show the plans and section of the main barracks buildings. The roof has a steep slope, partly to throw off tropical rain quickly, partly to allow locally obtained wooden shingles to be used as a fairly cool covering. The floor is raised 4 ft. above the ground, with a clear space beneath, the whole area below being covered with a seal of concrete to prevent exhalations from the soil. In this design the saving in walls and foundations is obvious, while the advantage in respect of stability, arising from the strength and continuity of the steel and its attachment to the foundation blocks, is also evident. As a matter of fact, there was another earthquake

shortly after the work was finished (not so serious, however, as the original one), and the buildings were quite unaffected.

The barracks were rapidly erected. Although all the materials, except the roof-covering and the ballast for the concrete, were sent from England, the troops were in occupation of their new quarters in Nov. 1907, ten months after the earthquake, and

etc. It was found that the building was warm and airy, and that the cost of maintenance was at least not greater than would have been the case with permanent construction. While the saving in cost lay mainly in walls and foundations, endeavour was made at the same time, by using some of the modern types of light roof-covering, to effect saving in the roof timbers. With all these economies in design there was a substantial reduction in cost, especially in the case of those military buildings where the walls and roof formed a large part of the whole. Thus stables, which had formerly cost about

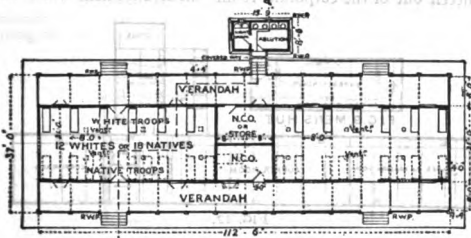

FIG. 2.



FIG. 3.



FIG. 4.

the universal opinion was expressed that the new barracks which cost £77,000 were a great improvement in comfort and convenience on the old ones which had cost, in days when building was relatively cheap, £95,000.

So far, then, the principle of light construction had been justified, but it did not follow that a type which was suitable to a hot climate like that of the West Indies would be equally applicable to Great Britain. At that time, however (1908), a small barrack was urgently required at Bordon, near Aldershot, for a field company of R.E., 150 men, with some accessory buildings such as sergeants' mess, recreation rooms, stables, etc., the estimated cost of which in "permanent" construction was £16,000; in "light construction" the estimate was £9,000, and this sum was sanctioned, and the work was carried out within the time estimate.

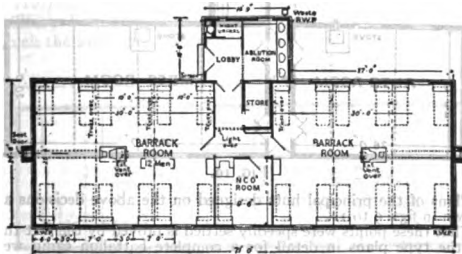

FIG. 5.



FIG. 6.

The plan of this building, shown in figs. 5 and 6, shows the same principles, formerly described, of 10-12 men in one room, with ablution room, etc., in close proximity, with a room for one N.C.O. between two barrack rooms, and with a company store under the same roof. The walls were built, between steel stanchions, of brick 5 in. thick, rendered with ordinary plaster inside, and rough cast outside, the steel stanchions carrying the weight of roof, windows,

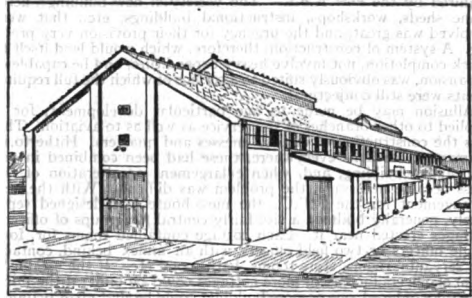

FIG. 7.

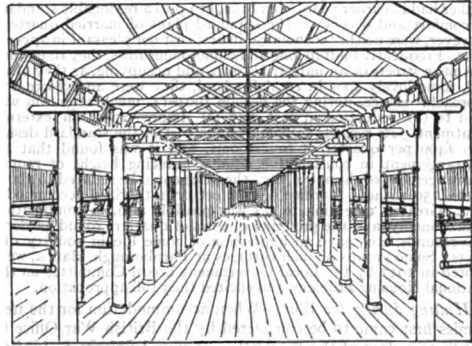

FIG. 8.

£60 per horse, were built on the new principle for about £32-£35, without any reduction of efficiency. Figs. 7 and 8 show the exterior and interior of such a stable and indicate the general style of building. A large riding-school built at Netheravon, Salisbury Plain, which was constructed on the "light-construction" principle, cost less than 2d. per cub. ft. as against 6d. to 7d. for a riding-school on the "permanent" principle. This is no doubt the most conspicuous example of saving in relative cost, as the building consists of little else than walls and roof.

Barracks on this principle, some of them double-storied, were built with satisfactory results at places as far distant from one another as Jersey, Worcester and Glasgow.

Another administrative change about this period also affected the design of important accessory buildings. Up to about 1909 it was laid down that the regimental institute (coffee bar, recreation room, etc.) should be separate from the "wet" canteen, used for malt liquor only, and also from the dining-rooms. In 1909, however, it was decided that, in any new construction, the wet canteen should be abolished, being replaced by a liquor bar in the institute, that there should be no restriction to the moderate use of malt liquor in connection with food, but that there should be no place for the sale of liquor only. The effect of this amalgamation of the institute and canteen was extended, where circumstances made it possible, to the amalgamation of the dining-rooms and supper bar, the men thus having all their meals served in the same room but with separate kitchens, one dealing with the regulation rations, and the other with the varied forms of refreshment purchased by the soldier voluntarily. This new departure was first embodied in the R.E. barracks at Bordon, and there found to be so satisfactory that it was followed in the new barracks at St. Peters, Jersey, where the combined dining and recreation rooms were made overlooking a cricket ground, with a large veranda forming a pleasant position for spectators of the game. It was possible, by the economies afforded by the light construction principle, to give these improvements without excessive



cost, more especially as there was substantial saving in having the three buildings, canteen, institute and dining-rooms, combined in one.

As the light-construction principle became more established in favour for buildings, including hospitals, in country districts especially, designs were contemplated for larger schemes (e.g. for the cavalry brigade barracks at Chiseldon, Wilts., and for an artillery brigade barracks near Fermoyle), at the time of the outbreak of the war in 1914, and were in part carried out. In 1912-4 this principle of design was mainly adopted in connexion with aviation buildings, required by the new R.F.C. The variety of new buildings, aeroplane sheds, workshops, instructional buildings, etc., that were involved was great, and the urgency for their provision very pressing. A system of construction, therefore, which would lend itself to quick completion, not involve heavy expenditure, and be capable of expansion, was obviously suited to a service of which the full requirements were still conjectural.

Allusion may be made to one particular development, for it applied to other branches of the service as well as to aviation. This was the construction of officers' messes and quarters. Hitherto, in permanent barracks everywhere, these had been combined in one continuous building, and, when enlargement or alteration of the mess became necessary, the problem was difficult. With the new arrangement for the R.F.C., the mess-house was designed separately, generally built on a site fairly central for groups of officers' cottages erected near it. Each cottage contained rooms for four single officers or two field officers, with an annex behind, containing servants' rooms, store-rooms, bath-room, etc. If the establishment of officers increased, more cottages could be built; if the numbers were reduced, one or more buildings could be shut up or reappropriated. This form of accommodation was very popular.

**Married Soldiers' Quarters.**—Accommodation for the married soldier had in earlier years been brought up to a reasonable standard of comfort and decency. The standard plans of married quarters, however, were neither economical in first cost nor pleasant in appearance. Frequently built in long and monotonous rows, they resembled the mean streets of an industrial town, and occupying, as they often did, some lovely spot in rural England, they were an eyesore and reproach. Hence, during the decade 1904-14, much attention was paid to (a) reduction in cost, and (b) improvement in external treatment. As regards (a) the average cost of the standard design was £400 per quarter of four rooms, and it was found that by rearrangement in constructive details, reducing height of rooms, rearrangement of chimneys, etc., the price could be reduced to about £220-£250 without sacrifice of comfort or authorized accommodation. Greater attention to (b) was possible also, in combination with economy; and the grouping of rows of quarters round gardens, playgrounds, etc., gave an impression of home life in country districts. Some groups of such cottages at Farnborough, Hants., were visited in 1917 by the Local Government Board Committee on the National Housing Problem, and elicited their full approbation.

**Hutting during the War.**—When accommodation for the new armies first came to be considered by the British War Office in the first 10 days of the World War, it was definitely decided to adopt some cheap design of hut which could be readily erected, and also easily adapted to any form of temporary material and to any reasonably level site. But there were many other considerations, e.g. what nature of accessory accommodation should be given, in view especially of recent rules regarding dining and recreation rooms, what sort of sanitary provision should be made, what method of lighting should be adopted, etc. As a result of consultation between the various War Office departments concerned the following points were settled: (a) That huts to hold 25 men (including one sergeant) should be constructed, giving 48 sq. ft. floor area per man (about 400 cub. ft. of interior space); (b) that there should be two principal spans of huts, viz. 20 ft. and 28 ft., and that as far as possible all the various buildings should be planned to fit one or other of these, so as to simplify the construction; thus, men's barracks, officers' quarters, regimental offices, quartermaster's stores, officers' mess and ante-room and kitchen, sergeants' mess and kitchen, were all planned to fit into the 20-ft. span, while men's dining-rooms, cook-house and regimental institute were on the 28-ft. span; (c) that there should be a battalion cook-house, fitted with the best known pattern of cooking-range and boilers for 1,000 men, and that there should be on either side of it dining-rooms for 500 men each, allowing 5 to 6 sq. ft. for each man on a total floor space of 2,800 sq. ft. Between the cook-house and the dining-rooms there should be sculleries; (d) that there should be in each battalion a bath-house with a central heating boiler and hot and cold water laid on to the showers, which should be in the proportion of 5 to every 100 men; (e) that there should be a

regimental institute of three rooms, viz. supper room, games room, and corporals' room; the bar and beer cellar to be between the supper room and corporals' room so that central serving could be arranged. There was also provided a kitchen and scullery in an annex. There was to be no "wet" canteen (though as a matter of fact some commanding officers made a canteen out of the corporals' room—an arrangement which was

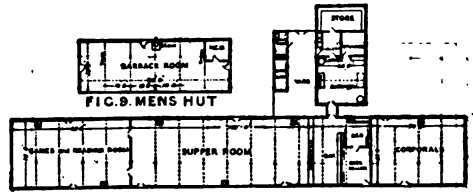

FIG. 12.

not in accordance with the original intention); (f) that there should be officers' and sergeants' messes planned to accommodate 30 officers and 50 sergeants respectively, and consisting of one block with mess-room and ante-room joined by a short passage with a kitchen block; (g) that four drying-rooms should be provided in which wet clothing could be hung, fitted with stoves and bars; (h) that the latrines should be on the dry-earth system, and that the ablution rooms and urinals should either lead into soak pits (in the chalk country in France this was invariably done) or into sewage filters; (i) that the lighting should be done by electric lamps and the wires carried on poles, not buried.

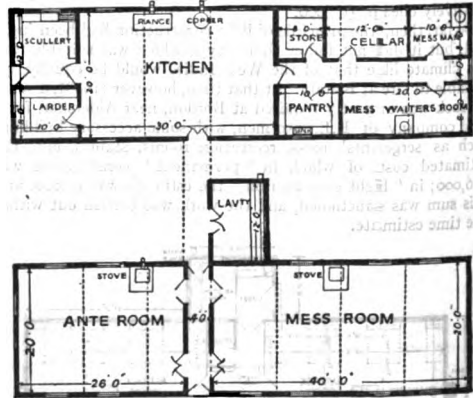

FIG. 10.

Plans of the principal huts designed on the above decisions are shown in figs. 9 to 12.

That these points were speedily settled is proved by the fact that all the type plans in detail for a complete battalion camp were approved 10 days after war was declared, and three days after it was decided to raise 100,000 men for the new army.

Considering the urgency of the matter, it would not have been a matter for surprise if extensive changes had to be made after the camps, so built, came into use. There were not, however, many changes, though several details were amended. Thus, it was decided to omit some of the accessories, such as the dining-rooms, on the ground that the men could dine in their sleeping-huts if necessary, and dining-rooms were only a recently authorized provision. The drying-rooms were frequently used for purposes other than that for which they were built, and in many camps they were not used at all, as the men found they lost their clothing when mixed up with others. In matters of detail, it was found better to have the huts made up in sections, bolted together *in situ*, rather than to build up with gangs of carpenters on the spot. This building by sections enabled the work to be done chiefly in central workshops and very rapidly put together on the site. Incidentally, sectional huts fetched a better price after the war than others, for obvious reasons.

As regards materials, the huts were at first founded on brick piers. This was a mistake, and it would have been better from the outset to

have had a short stout pile of creosoted wood. The brick piers involved bricklayers and bricks and mortar, and the provision of these meant delay in some cases. The framework of walls, roofs and floors was mainly red fir of market scantlings, but the multiplication of these scantlings caused a famine in the market and much complaint. Yet it is hard to see how this could have been avoided, except by using a material more costly, or else by taking more time in construction. A light steel framework was used in some cases, with expanded metal plastered on one side, and sheet iron painted in the interior of the room, but this was costly compared to timber. For lining match-boarding and 3-ply timber were used. Asbestos sheets

During the decade before the World War there were two large permanent hospitals built for military needs, at Portsmouth and Dublin, but there were many small "reception stations" for examination, observation, accidents, etc., and one fairly big hospital for women, built of light construction, and found to be most satisfactory in every way.

When the war broke out in 1914 the whole question of suitable hospital design came necessarily into great prominence, and the following were the main points which were then settled:— (a) The wards should contain 25 beds, *i.e.* 24 ordinary cases and one special case in a separate small room; (b) the nurse's duty room should be adjacent to the entrance to the main ward, divided by the central passage from the special-case ward; (c) beyond the nurse's duty room should be the ward scullery and on the opposite side of the central passage the linen cupboard; (d) beyond this a transverse passage so as to give clear ventilation between the foregoing parts of the ward and the ablution and bath-rooms, which come then at the end of the hut nearest to the main entrance.

This gives a hut 140 ft. long by 20 ft. 8 in. wide (see fig. 13). Of the total area a little more than one-fourth is taken up by accessory accommodation, and it is doubtful whether as much as one case out of 24 requires to be specially treated. However, the above represented what may be called the nucleus typical ward, and hundreds were erected either exactly the same as this or with minor modifications, both in England at the large training-centres, and in France in the area occupied by British troops.

The administrative offices, which are always an important adjunct in a hospital, were combined in a hut 160 ft. by 28 ft., shown in fig. 14. At one end is the out-patient department with consulting-room, waiting-room and dispensary, divided by a corridor from the offices of the principal medical officer, his clerks and registrars, beyond which are the offices of the matron, nursing sisters' duty room, and clinical laboratory. At the rear of these are the orderly medical officers' room and the medical board room.

In the field there was in some cases a reception block where all wounded cases were brought, given temporary treatment, food, etc., and examined by the medical officers prior to being sent to one or other of the special wards for surgical attention, etc.

In a typical operation hut, 51 ft. by 36 ft., a wide double door, to admit a stretcher, leads into a hall, from which open on one side a Röntgen-ray room, an anaesthetic room, and the operation room, while on the other side are the sterilizing-rooms, preparation room, store and photographic rooms. The patient, after X-ray examination, is taken into the anaesthetic room and thence, when unconscious, into the operation room, about 20 ft. square, with windows opening to the north.

The hospital arrangements in the field varied in some nature of detail, but the same general principles were followed. Hospital kitchens were based on the knowledge that, while some patients could come to a dining-room, there were many who would

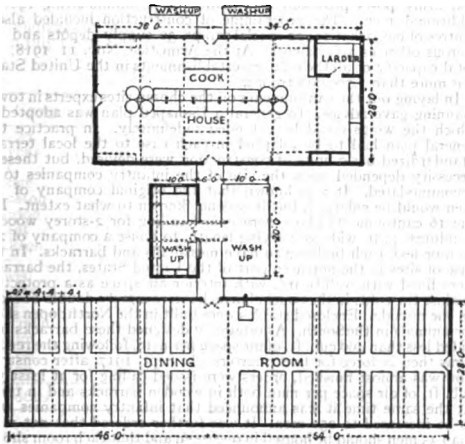

FIG. 11.

were used at first but were found very brittle unless the backing of timbers was fairly (say 18 in.) close, and "S X boarding" and similar fibrous matter was also employed, but not found suitable. The floors were in most cases of planking, grooved and tongued.

In France excellent sectional huts were made up by French workmen, and the carpentry was somewhat on different lines to that employed in England, lighter scantlings in roofs and subsidiary ties and struts being used. Many of the sectional huts there had the sides at a slight angle to the vertical, the sloping side forming like a "mansard" roof, part of the truss supporting the roof-covering.

**Hospitals.**—It was pointed out in the earlier article that military hospitals, where built permanently, are designed on much the same lines as those in civil life.

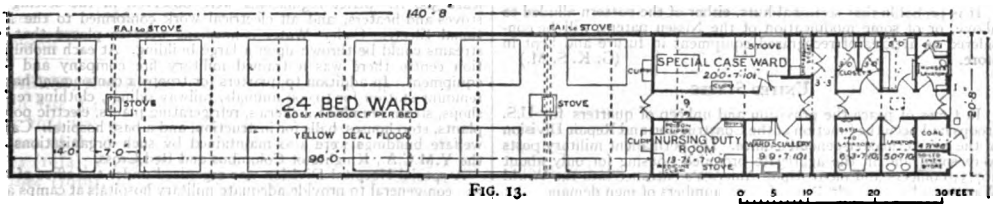

FIG. 13.

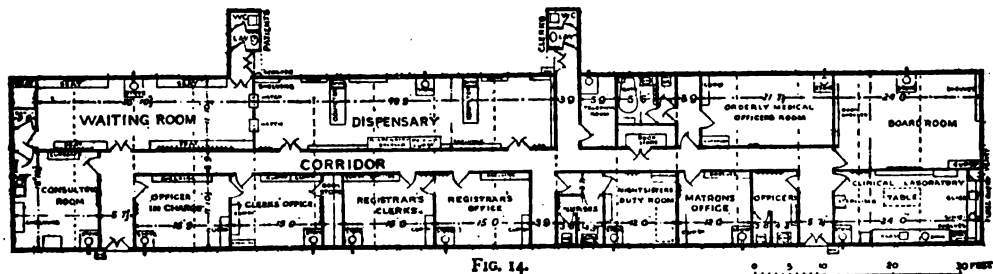

FIG. 14.

have to be fed in their beds, and that the diets would have to be varied to suit individuals. The cooking and distribution arrangements had therefore to be on a more elaborate plan than is provided for in ordinary barracks.

Other hospital buildings, such as dining-room, supply stores (for bedding and utensils), pack store, officers' quarters, nursing sisters' accommodation, and barrack huts for orderlies, followed the usual lines for ordinary barrack huts and quarters with certain modifications. There were, however, two other adjuncts of importance in field hospitals, viz. mortuary block, and disinfecting block, which deserve a brief description.

The former is a hut 30 ft. by 14 ft. 8 in., with a post-mortem chamber 14 ft. by 11 ft. 9 in. at one end, fitted with table, stove, cupboard, sink and shelves, and with wide double doors. Next to it is the body chamber, about 8 ft. square, and beyond that a "viewing chamber," entered by a separate lobby where friends of the deceased can enter and see the corpse prior to burial.

The disinfecting-hut has a receiving-room 11 ft. 9 in. by 14 ft., into which the foul clothing, bedding, etc., is brought, and placed in an air-tight disinfectant, one end of which opens into the receiving-room, and the other into an adjacent chamber, the issuing-room, whence, after treatment in the disinfectant, the material is removed. There is a small incinerator in another chamber and, for those materials which require liquid disinfectants, there are other rooms provided.

**Portable Huts of Special Design.**—There were many types of portable light huts made of wooden framework and canvas. They were not found satisfactory for prolonged use, although many were found very useful for rapid work and in emergencies. The principles were the same in most cases, viz. framing of wooden scantlings about 2 in. by 1½ in., covered with canvas prepared with some sort of waterproof solution, and, when unfolded, fixed in position by light bolts or by hooks. The disadvantages were that they did not afford better protection against cold and heat than tents, and that the edges of the framing caused the parts of the canvas in contact with them to wear rapidly.

Portable huts of corrugated steel bent to a circular form were, however, most useful. The model invented by Lt.-Col. Nissen, R.E., was largely used in the field. These huts were in two patterns, differing from one another only in the fact that in the larger one there was a central ridge opening admitting air and light along the summit above the normal roof level. The huts were formed of light steel ribs of H-section bent in a semi-circular form, and resting on plates for foundations. Over these, corrugated steel in three parts, clipped together at the edges, and fastened to the ribs, is laid. Under the corrugated steel, and fitting into the flanges of the ribs, are light boards to form a lining. The floors, of wood, are made in sections and fit in between the parts of the steel framing that reach the ground. At the ends of the huts are doors and windows, with match-boarding to fill the unoccupied spaces. Thus the corrugated steel covering forms roof and walls, while light and ventilation, etc., is obtained from each end. The great advantage of these huts was that the materials could be packed up together so as to take up little space; and the one disadvantage was that, at a time when steel was much required for other services, it was difficult to get supplies of these huts in large numbers.

It is probable that sectional huts, either of the pattern alluded to above, or of some modification of the Nissen patent, will be considered as articles of recognized equipment in future and kept in store. (G. K. S. M.)

#### UNITED STATES

In times of peace the provision and upkeep of quarters for U.S. troops had been the function of the Construction and Repair Division of the quartermaster-general's office. The permanent military posts were small and in the aggregate provided housing for only about 107,340 officers and men. Upon America's entrance into the World War the subsequent drafting of large numbers of men demanded an unprecedented rapidity of construction. Existing facilities were wholly inadequate. As authorized by a letter of the adjutant-general, May 19 1917, a separate Cantonment Division was created in the office of the quartermaster-general, reporting directly to the Secretary of War, and charged with the formidable task of housing the new army. On Oct. 10 1917, the old Construction and Repair Division was abolished and its duties given to the new organization, which in Feb. 1918 was placed under the Operations Division of the office of the chief-of-staff. It was thus detached from the office of the quartermaster-general as an independent service. On March 13 1918 its name was changed to the Construction Division.

On May 17 1917, one month after the declaration of war, the commanding generals of the different military departments were ordered to select 16 sites for the erection of cantonments (National Army Cantonments) to receive the troops to be chosen by the selective draft and also 16 sites for camps of the mobilized National Guard (National Guard Camps). Already in April tentative plans had been drawn for barracks and mess-halls, these to be wooden structures one storey in height, 20 ft. wide and of varying length, and this

type was used for certain buildings in the National Guard Camps, in which, however, the troops were housed under canvas. These camps were all situated in the southern States, and required less protection against cold. Actual construction of cantonments began late in June and of camps about a month later. The last cantonment site was chosen July 6. It was necessary that the 32 mobilization centres be ready for the reception of the first contingents within 90 days. The cantonments naturally presented the most difficult construction problem, but by Sept. 4 they were prepared to house 430,000 men and their capacity was increased to 655,000 by the close of 1917 and subsequently expanded to 770,000. The National Guard camps provided quarters for 450,000 officers and men. At the regular army posts provision was made for accommodating 140,000 additional men. The programme of construction included also 4 centres of embarkation, 22 special camps, 30 supply depôts and numerous other establishments. At the Armistice, Nov. 11 1918, the total capacity of all the military establishments in the United States was more than 1,700,000 troops.

In laying out the cantonments on the chosen sites experts in town-planning gave advice. In general a U-shaped plan was adopted in which the wings could be extended indefinitely. In practice this general plan had to be adapted in each case to the local terrain. Standardized basic units of construction were devised, but these of necessity depended upon the size of the infantry companies to be accommodated. It was known that the original company of 150 men would be enlarged, but it was not known to what extent. For the 16 cantonments plans were issued calling for 2-storey wooden buildings, 43 ft. wide, of varying length, to house a company of 200 men or less, each building to have mess-halls and barracks. In the case of sites in the northern part of the United States, the barracks were lined with wall-board, with interior air space as a protection against the cold; in the South, barracks were merely double-boarded on the outside. Enclosed stables were built in the North; open sheds for animals in the South. As originally designed these barracks provided less than 400 cub. ft. of air space per man, following the regulations then in force for tent quarters. In Sept. 1917, after construction was almost finished, orders were issued calling for at least 500 cub. ft. of air space per man both in wooden barracks and in tents. At the same time it was announced that infantry companies were to be increased to 250 men. It was further ordered that not more than 35 men should be housed in one room and that each room should have four outside walls with windows and should have an independent entrance. This required a complete rearrangement of barrack interiors and much additional construction so that one company could be quartered in two adjacent buildings. For subsequent construction of barracks new plans were drawn, calling for buildings of a maximum size of 30 by 60 ft., 2-storeys high, with accommodations for 66 men. For a single company four such barracks were required, besides separate buildings for mess-halls and lavatories. In the beginning one-storey quarters for officers had been designed and these were retained throughout the period of mobilization. As to the grouping of buildings, a standard block about 450 by 800 ft. was chosen. Each block contained barracks for eight companies of 250 men. Beyond one end of the block were the officers' quarters; at the opposite end were placed the stables. In constructing rows of buildings the general plan was to leave at least 500 ft. between the rows as protection against the spread of fire. In each row not more than two blocks were grouped; further groups were separated by at least 300 ft. Strict regulations were observed in the setting of stoves and heaters, and all electrical work conformed to the National Electric Code. Water connections were so placed that 16 streams could be thrown upon a large building. At each mobilization centre there was a trained military fire company and full equipment. In addition to quarters for troops a cantonment had a remount station for 10,000 animals, railway sidings, clothing repair shops, steam laundries, bakeries, refrigerating plants, electric power plants, storehouses, halls for instruction, and a base hospital. Camp welfare buildings were also maintained by such organizations as the Y.M.C.A., Knights of Columbus and Red Cross.

A special Hospital Division was organized under the office of the surgeon-general to provide adequate military hospitals at camps and cantonments. In the autumn of 1917 these 32 centres each had fully equipped hospital facilities with a combined capacity of 44,000 beds. The larger base hospitals had a capacity of 1,000 beds, and comprised 60 buildings built at least 60 ft. apart, all connected by enclosed corridors. They had separate steam-heating plants and laundries, and were equipped with modern plumbing. Each ward had a capacity of from 60 to 80 beds and provided usually 1,000 (never less than 800) cub. ft. of air per patient. The buildings were of the 2-storey type. In addition each regiment possessed a medical dispensary and a small hospital containing 60 beds.

To provide water, connexion was made, when practicable, with the mains of existing systems. In other cases it was derived from wells or streams and, if advisable, thoroughly purified. In the cantonments the generous quantity of about 40 gal. a day per man was provided, and in addition about 15 gal. each for animals. In the camps the quantity made accessible was smaller as there was less danger of disastrous fires in quarters under canvas. For each company there was a lavatory with 12 vitreous bowls with wooden seats and a urinal trough 18 ft. long, besides 10 shower-baths and a wash

trough 22 ft. long; a storage tank of 560 gal. capacity attached to a heater supplied abundant hot water. Where possible the sewage was discharged directly into running streams; where desirable, septic tanks were installed for its treatment. Steam-heating was provided for all hospitals, and in four instances for the whole cantonment because of rigorous climatic conditions. In 12 cantonments and in the 16 camps stoves for heating were placed in the various apartments. Central power plants furnished electric lighting in all cases. No special type of road was required, but specifications were prepared for brick, cement concrete, bituminous macadam, and water-bound macadam. The width was usually 18 ft., but in some cases 24. Such walks as were built were usually of wood.

Tables I. and II., from official reports of the War Department, give the name and location of each cantonment and camp, the number of buildings erected and the amounts allotted for construction (from July 1 1917 to June 30 1918 inclusive):—

TABLE I.—National Army Cantonments.

Camp	Location	Buildings	Capacity	Cost
Custer	Battle Creek, Mich.	1,282	35,458	\$ 9,748,694
Devens	Ayer, Mass.	1,334	36,832	11,160,839
Dix	Wrightstown, N. J.	1,414	42,806	11,687,666
Dodge	Des Moines, Ia.	1,409	42,227	8,178,402
Funston	Fort Riley, Kan.	1,401	42,806	10,715,447
Gordon	Atlanta, Ga.	1,435	41,162	8,944,980
Grant	Rockford, Ill.	1,515	42,819	9,900,238
Jackson	Columbia, S. C.	1,554	44,009	10,723,383
Lee	Am. Lake, Wash.	1,532	49,721	14,004,093
Lewis	Petersburg, Va.	1,667	46,232	8,319,841
Mende	Admiral, Md.	1,460	42,830	11,848,948
Pike	Little Rock, Ark.	1,488	43,843	9,603,602
Sherman	Chillicothe, O.	1,378	39,994	10,633,476
Taylor	Louisville, Ky.	1,563	45,424	8,057,065
Travis	Ft. Houston, Tex.	1,439	42,800	7,641,379
Upton	Yaphank, N. Y.	1,486	43,567	12,554,994
Totals		23,367	682,449	\$163,723,047

TABLE II.—National Guard Camps.

Camp	Location	Buildings	Capacity	Cost
Beauregard	Alexandria, La.	1,068	29,121	\$3,835,218
Bowie	Fort Worth, Tex.	1,329	44,899	3,159,282
Cody	Deming, N. M.	1,299	44,959	3,753,088
Doniphan	Fort Sill, Okla.	1,267	46,183	2,796,228
Fremont	Palo Alto, Cal.	1,124	30,000	2,503,554
Greene	Charlotte, N. C.	1,125	48,305	4,033,081
Hancock	Augusta, Ga.	1,319	48,099	3,218,142
Kearny	Linda Vista, Cal.	848	32,066	3,660,948
Logan	Houston, Tex.	1,329	44,899	3,026,199
MacArthur	Waco, Tex.	1,284	45,074	3,049,519
McClellan	Annisson, Ala.	1,551	57,748	4,270,516
Sevier	Greenville, S. C.	1,218	41,693	2,949,994
Shelby	Hattiesburg, Miss.	1,206	36,010	4,389,314
Sheridan	Montgomery, Ala.	1,277	41,953	2,900,027
Wadsworth	Spartanburg, S. C.	1,414	56,249	3,761,510
Wheeler	Macon, Ga.	1,229	43,011	3,303,162
Totals		19,887	690,269	\$54,609,682

**BARRES, MAURICE** (1862—), French novelist and politician (see 3,434), published *La Colline inspirée* (1913); but after 1914 was occupied almost exclusively with subjects arising out of the World War. *La grande Pitié des Eglises Françaises* (1914); *L'Âme française et la Guerre* (1915); *La Lorraine dévastée* (1919); *Le Roman de l'Énergie nationale* (1919) were amongst his later works. He also published literary addresses and lectures.

**BARRIE, SIR JAMES MATTHEW, BART.** (1860—), British novelist and dramatist (see 3,435), devoted himself after 1910 almost exclusively to drama. He produced, amongst other plays, *Rosalind* (1912); *The Will and The Adored One* (1913); *Der Tag* (1914); *Rosy Rapture* (1915); *A Kiss for Cinderella* (1916); *Dear Brutus* (1917); and *Mary Rose* (1920). He was created a baronet in 1913.

**BARRILL, ANTONIO GIULIO** (1836—1908), Italian novelist (see 3,436), died Aug. 13 1908. His last work, a volume of poems, *Canzoni al vento*, was published posthumously in 1911.

**BARRINGTON, RUTLAND** (GEORGE RUTLAND FLEET) (1853—), English actor, was born at Penge, Kent, Jan. 15 1853, and was educated at Merchant Taylors' school. He appeared

first at the Olympic theatre, London, in 1874. Three years later he joined D'Oyley Carte's company at the Opera Comique and appeared in Gilbert and Sullivan's opera *The Sorcerer*. From that time onwards he was identified with the fortunes of the long series of these operas, which ran continuously from 1877 to 1889 and were revived at frequent intervals. In 1908 and 1911 he published two volumes of *Recollections*.

**BARROW-IN-FURNESS**, England (see 3,443).—The pop. (63,770 in 1911), which more than doubled during the World War, was estimated at 78,000 in 1920. The shipbuilding yards developed greatly and war vessels of all types, including dreadnoughts and submarines, were constructed during the war. The Cavendish dock adjoining the Ramsden dock on the E., 146 ac. in extent, has been leased by the Furness Railway Co. to the firm of Vickers Ltd. for the construction of airship sheds and for the manoeuvring of airships and dirigibles. The airship factory is situated on Walney I., which is connected with the mainland by a bridge with an opening span of 120 ft. for the passage of vessels. Among the public buildings constructed since 1911 are the town hall with a clock tower 170 ft. high, built at a cost of 170,000, and a working-men's club and institute, the gift of a former mayor; a new Carnegie library was in course of erection in 1921.

Vickerstown on Walney I. is a rapidly growing township of model workmen's houses and is becoming more and more a residential suburb of Barrow. It has the James Dunn park on the E. and the Biggar Bank, a public recreation ground facing the Irish Sea, on the W. side of the island.

**BARRY, ALFRED** (1826—1910), English bishop (see 3,444), died at Windsor April 1 1910.

**BARRYMORE, ETHEL** (1879—), American actress, was born Aug. 15 1879 in Philadelphia, and was educated at the Convent of Notre Dame in that city. She made her début in 1896 in the company of her uncle, John Drew. In 1897 she first appeared in England in *Secret Service*, and with Sir Henry Irving's company in *The Bells* and *Peter the Great* (1898). She was first starred by Charles Frohman in *Captain Jenks* in 1900, and subsequently became one of the leading actresses in the United States.

Her brother, JOHN BARRYMORE (1882—), who first appeared on the stage in *Magda* in 1903, had also, by 1921, established his position as one of the foremost American actors as had also another brother, LIONEL, whose first appearance was in 1893.

**BARTELS, HANS VON** (1856—1913), German painter (see 3,447), died at Munich Oct. 5 1913.

**BARTHOLOMEW, JOHN GEORGE** (1860—1920), Scottish cartographer, was born in Edinburgh March 22 1860, the elder son of John Bartholomew, also a cartographer (see 3,450). J. G. Bartholomew was educated at the Edinburgh high school and university, and succeeded his father as head of the business of the Edinburgh Geographical Institute. In this capacity he maintained and improved the unsurpassed reputation for scientific cartography and exquisite reproduction which the firm had already acquired; in particular, he extended and popularized the use of "layer" colours exhibiting relief of the land, applying this method not only in the reduction of ordnance survey maps but in many other instances, including general atlases, of which the finest example is that published by *The Times* since the close of the World War. Bartholomew was associated with Sir John Murray and others in connexion with the mapping of results of the "Challenger" expedition, the bathymetrical survey of the Scottish lochs, and other scientific studies. He planned a physical atlas on a large scale and with the cooperation of Dr. A. J. Herbertson published the *Atlas of Meteorology* in 1899, which at once became a standard work. The volume on zoogeography, in collaboration with W. Eagle Clarke and P. H. Grimshaw, followed in 1911. His written works include a bibliography of authoritative maps of all countries (1891) and a gazetteer of the British Isles; and he interested himself greatly in geographical education, helping to found the lectureship in geography in the university of

Edinburgh, as well as the Royal Scottish Geographical Society. He was one of the founders and for many years hon sec of the Royal Scottish Geographical Society. He died at Cintra April 13 1920, but the management of the Edinburgh Geographical Institute remained in his family.

**BARTHO, LOUIS** (1862— ), French statesman, advocate, author, journalist, and lecturer, was born at Oleron Aug. 25 1862. He was elected to Parliament in 1889, and five years later he became Minister of Public Works. He was successively Minister of the Interior (Aug. 1896 to June 1898), Minister of Public Works (March-Oct. 1906 and in the subsequent Clemenceau Cabinet until July 1909), Minister of Justice from July 1909 until March 1913, prime minister from May 22 to Dec. 2 1913, Minister of State in the Painlevé Ministry during the World War, subsequently succeeding Ribot as Minister for Foreign Affairs; Minister of War Jan. 16 1921. His most notable political achievement was the manner in which he pushed through the Three Years' Service Bill, which was a response to German military preparations before the war of 1914. He was elected a member of the French Academy in 1918.

**BARTON, CLARA** (1821-1912), American philanthropist (see 3 452), died at Glen Echo, Md., April 12 1912. She is the only woman whose name has been taken by a post of the G.A.R.

See Mrs. Cora Bacon-Foster, *Clara Barton, Humanitarian* (1918), which outlines her career with extracts from records, letters, and contemporary papers.

**BARTON, SIR EDMUND** (1849-1920), Australian statesman and judge, was born at Sydney, N.S.W., Jan. 18 1849. He was educated at the Sydney grammar school and the university of Sydney, where he won many distinctions, and was called to the N.S.W. bar in 1871, becoming Q.C. in 1889. At the age of 30 he entered the N.S.W. Legislature as representative for Sydney University, and remained a member of either the Assembly or the Legislative Council for many years. During 1883-7 he was Speaker of the Assembly and in 1889 and again in 1891 he was for a time Attorney General. In 1897, after the death of Sir Henry Parkes, he became senior representative for N.S.W. to the Federal Convention. He was a keen supporter of Federation and in 1900 led the delegation sent to London with the Australian Commonwealth bill. In 1901 he became the first Prime Minister of federated Australia, holding also the portfolio of External Affairs. His two years of office were much troubled by party strife. He had been a life-long supporter of Preference, but his majority over Sir George Reid and the Free Traders was small and the Labour party held the balance. In 1903 he was glad to resign office and accept the appointment of Senior Puisne Judge of the High Court of Australia. In 1901 he was sworn of the Privy Council and in 1902 he was created G.C.M.G. He died suddenly at Medlow Bath, near Sydney, Jan. 6 1920. Known affectionately as the "Father of Australia," Edmund Barton inspired through his long career as a politician a deep personal devotion. His magnificent talents were used more for the advancement of his ideals and the help of his friends than in the service of his personal ambitions. Like a genial Dr. Johnson in conversation, he made easy captives of British statesmen on his visits to London. One of his sons was the first Rhodes scholar from N.S.W. to Oxford.

**BARUCH, BERNARD MANNES** (1870— ), American financier, was born in Camden, S.C., Aug. 19 1870. He graduated from the College of the City of New York in 1889. For many years he was a member of the New York Stock Exchange but sold his seat in 1917. He first came into national prominence when appointed by President Wilson as a member of the advisory committee of the Council of National Defense in 1916, and after America's entrance into the World War he held many important positions. He was chairman of the Committee on Raw Materials, Minerals and Metals, and was in charge of purchases by the War Industries Board. He was also appointed a member of the commission in charge of all purchases made for the Allies. He became chairman of the War Industries Board in 1918 but resigned at the close of the

year. In 1919 he was a member of the Supreme Economic Council of the Peace Conference in Paris and in the same year was appointed by President Wilson as a member of the Industrial Conference in Washington. He wrote *The Making of the Reparation and Economic Sections of the Treaty* (1920).

**BASCOM, JOHN** (1827-1911), American educationist and philosophical writer (see 3 458), died Oct. 3 1911 at Williamstown, Mass.

**BASEBALL**: see SPORTS AND GAMES.

**BASHFORTH, FRANCIS** (1819-1912), English mathematician, was born at Thurnscoe, Yorks., Jan. 8 1819. Second wrangler in 1841, he was elected a fellow of St. John's College, Cambridge; and having taken orders, he was rector of Minting, Lincs., from 1857 to 1908. His interest in ballistics led him to make a series of experiments between 1864 and 1880, upon which our present knowledge of air-resistance is founded (see 3 271). The Bashforth chronograph for recording the velocity of shot (see 6 303) was his invention, and he received a pension from the Government and a grant of £2,000 for his work. For some time he was professor of applied mathematics to the advanced class of artillery officers at Woolwich. He died at Woodhall Spa, Lincs., Feb. 12 1912.

**BASSERMAN, ERNST** (1854-1917), German politician and leader of the National Liberal party, was born June 26 1854 at Wolsing in the Black Forest. He began his career in 1880 as a lawyer at Mannheim. From 1885 to 1892 he was a deputy in the Baden Diet, and from 1893, with brief interruptions, a member of the Reichstag. In 1905 the National Liberal party elected him as president of the party. In the Reichstag he enjoyed a high reputation as a speaker, and he exercised an eminent influence on the course of politics. He died July 17 1917 at Mannheim.

**BASTIAN, ADOLF** (1826-1905), German ethnologist (see 3 500), died in 1905.

**BATAILLE, FÉLIX HENRY** (1872— ), French poet and playwright, was born at Nîmes April 4 1872, and was educated at the lycée Henri IV. at Paris and the lycée Janson de Saille. He brought out his first play, *La Belle au bois dormant*, in 1894 and his first volume of poetry, *La Chambre blanche*, in 1895. His dramatic work includes *Le Lépreux* (1896); *Ton Sang and L'Enchantement* (1900); *Le Mœque and Resurrection* (1902); *Maman Colibri* (1904); *La Marche Nuptiale* (1905); *Poliche* (1906); *Les Flambeaux* (1912); *Le Phalène* (1913). Among his later poems may be mentioned *La Divine Tragédie* (1916) and *La Quadrature de l'Amour* (1920). *Notre Image*, in which Réjane made one of her last appearances; *Les Sœurs d'Amour* (1919), *L'Homme à la Rose* (1920) and *La Tendresse* (1921), are among his recent successful plays.

**BATEMAN, KATE** [Mrs. Crowe] (1842-1917), American actress (see 3 508), died in London April 8 1917. She had since 1892 conducted a school of acting, appearing only rarely on the stage; but she played Lady Kew in *Colonel Newcome* at His Majesty's theatre, London, in 1906, the nurse in *Medea*, at the Savoy theatre in 1907 and Kirijipa in *False Gods* at His Majesty's in 1909.

**BATESON, WILLIAM** (1861— ), British biologist, was born at Whitby Aug. 8 1861, the son of the Rev. W. A. Bateson, some time master of St. John's College, Cambridge. He was educated at Rugby and St. John's College, Cambridge, and became famous for his biological investigations, which included important researches on Mendelism and the determination of sex. In 1894 he published *Materials for the Study of Variation*. In 1907 he gave the Silliman lecture at Yale University, from 1908 to 1909 was professor of biology at Cambridge, and in 1910 was appointed director of the John Innes Horticultural Institution at Merton Park, Surrey. From 1912 to 1914 he was Fullerian professor of physiology at the Royal Institution, and in 1914 was president of the British Association. He received the Darwin medal of the Royal Society, of which he was a fellow, in 1904. His other works include *Mendel's Principles of Heredity* (1902) and *Problems of Genetics* (1913), besides many short studies on biological subjects.

**BAUER, GUSTAV** (1870- ), German Socialist, and first chancellor of the republican German Reich, was born Jan. 6 1870 at Darkehnen in East Prussia. At an early stage of his career he took up the secretarial work of the German Trades Unions movement and in 1908 became president of the general committee of the Trades Unions of Germany. Elected a member of the old Reichstag in 1912, he was appointed on Oct. 5 1918 Secretary of State for the Department of Labour in the Government of Prince Max of Baden, the last Government under the old régime. In Feb. 1919 he was appointed Minister of Labour in the republican Government of the German Reich and on June 21 of the same year president of the Ministry which was installed to accept the Peace Treaty of Versailles. The new constitution of the Reich having been enacted, the president of the Ministry resumed, in accordance with its provisions, the old title of chancellor (*Reichskanzler*) and Bauer was the first to hold this office under the republican régime. He remained chancellor until the Kapp coup of March 1920, when he fled with the president of the Reich, Ebert, and the rest of the Ministry to Dresden and afterwards to Stuttgart. On their return the Ministry was reconstructed and Bauer made way for the second republican chancellor, Hermann Müller, himself becoming for a brief period the Minister of the Treasury (*Reichsschatzminister*).

**BAUER, OTTO** (1881- ), Austrian politician, was born Sept. 5 1881, the son of a Viennese manufacturer. He entered the faculty of jurisprudence at the university of Vienna, devoting himself especially to the study of economics, principally under Böhm-Bawerk. As a student he took an active part in the work of the Social Democratic party, and was early a zealous contributor to the *Arbeiter-Zeitung*. He served in the campaign of 1914, and was a prisoner of war in Russia from 1915 to 1917. After his return to Vienna he was elected a member of the committee of the Social Democratic party, and became the leader of the increasingly influential Left group. After the revolution he succeeded, in Nov. 1918, his master Viktor Adler as State Secretary for Foreign Affairs. In this capacity he energetically supported the idea of the union of German Austria with Germany. During the peace negotiations at St. Germain in July 1919 he retired from his office, but remained until Oct. a member of the Socialization Commission. He subsequently became one of the most conspicuous leaders of the Social Democratic party in the Constituent National Assembly and in the National Parliament (*Nationalrat*), his speeches dealing mainly with financial questions, such as the tax on capital, and foreign affairs.

His works are: *Die Nationalitätenfrage und die Sozialdemokratie* (1908); *Die Teuerung* (1911); *Balkankrieg und Deutsche Weltpolitik* (1912); *Die russische Revolution und das europäische Proletariat* (1917); *Bolschewismus oder Sozialdemokratie?* (1920).

**BAVARIA**, a territory and free state of Germany (see 3.543).—The pop. of Bavaria, with which Coburg had voluntarily united in 1920, was, according to the census of 1919, 7,140,333; without Coburg 7,066,024, in 1910 6,887,291.

*Political History, 1910-21*.—The two last years of the life of the Prince-Regent Luitpold were characterized by an intensification of internal political conflicts which arose from the increasing estrangement between the Podewils Government and the majority of the Diet (*Landtag*) consisting of the Catholic Centre party.

In the summer of 1910 Minister of Finance von Pfaff had succeeded without much difficulty in passing an important measure of taxation reform by the vote of the non-Socialist parties and had thus been able to introduce a general income tax in order to consolidate the financial position of the country. But the resistance with which, in the following year, the Minister of Communications, von Frauendorfer, and the whole Cabinet met the demand of the Centre for the suppression of the South German Railway Men's Union, on the ground of its alleged Socialist tendencies, soon led to an open conflict between the majority and the Government. On Nov. 8 1911 the majority of the Finance Committee of the Diet refused to discuss with Frauendorfer the vote for the estimates of his department. The Government, in the hope of solving the conflict and relaxing the strain of the internal situation, induced the aged Regent to order the dissolution of the Diet. This was done on Nov. 14. For the elections which took place on Feb. 5 1912, the Liberal parties, the

Social Democrats and the Bavarian Farmers' League (*Bayerischer Bauernbund*) concluded an alliance the effect of which was that only one candidate was set up by the allied parties in each constituency against the candidate of the Centre. The Podewils Cabinet resigned on the day of the elections in order to give the Crown a free hand according to the results. These results did not fulfil expectations. The Centre returned an absolute majority in the Diet, although their allies, the Conservatives, came back with much less than half their former strength. The Liberals, the Social Democrats and the Farmers' League gained seats, but not enough to overthrow the Clerical-Conservative majority.

The Prince-Regent entrusted the university professor, Dr. Baron von Hertling (afterwards Chancellor of the German Empire 1917-8), who also sat in the Reichstag in Berlin as a member of the Catholic Centre party, with the formation of a ministry. Baron von Hertling acted in the sense of his commission; he selected two of the leading members of the Centre and filled the remaining posts with politically colourless officials. The hope that the elections would have relieved the strained condition of internal politics was not at first fulfilled. On the contrary the controversy about the treatment of the South German Railway Men's Union was further embittered by the issue of an ordinance which demanded from the workers on the railways the signature of a paper certifying their loyalty; and the issue of a secret ordinance on toleration of the exercise of priestly functions by members of the Jesuit Order, which was still forbidden by a Law of the empire, roused the opposition to the Hertling Ministry to increased violence. By a decision of the Federal Council of Nov. 28 1912 disavowing this secret edict of the Bavarian Government, the controversy about the Jesuits was eliminated, but new subjects of conflict soon arose.

On Dec. 12 1912 Prince-Regent Luitpold died in his ninety-second year. His son Louis assumed the regency, and took the oath to the constitution on Dec. 21.

The movement for ending the regency (which had lasted since 1886 and was due to the insanity of King Otto) and conferring the royal dignity upon the Regent, coincided in point of time with the bill introduced by the Government for increasing the Civil List from 4.2 to 5.4 million marks (£270,000). After protracted debates, by which the internal conflicts of the country were intensified, the Diet on Oct. 30 1913 passed, by a majority of 122 against 27 Social Democratic votes, an amendment to the constitution ending the regency and enabling the Prince-Regent, Louis, to assume royal authority. After the Upper Chamber had given its assent, Prince Louis issued a proclamation on Nov. 5 announcing his assumption of the crown. The demand for the increase in the Civil List was granted by the Diet on Nov. 21 against a minority of 50 Liberals and Social Democrats.

*The War Period*.—The truce to party politics (*Burgfrieden*), which had completely silenced political conflicts at the outbreak of the war, continued as an after-effect, to mitigate them. In 1915 the edict regarding the declaration of loyalty to be signed by the railway-men was withdrawn; in 1916 the Minister of the Interior, von Soden, who was widely attacked on the ground of his agrarian food policy, was replaced by the former Minister of the Interior, von Brettreich, while Gen. von Hellin-grath replaced Gen. von Kress as Minister of War. In the later years of the war, when discontent due to the oppressive war burdens was accompanied by increasingly powerful efforts to carry domestic reform, resolutions of the Social Democrats in favour of proportional representation, a parliamentary régime, and the abolition of the Upper Chamber were repeatedly rejected by the majority of the Chamber of Deputies; but the Government promised at least to introduce a bill for the overdue reform of the Upper House (*Kammer der Reichsräte*). On Nov. 10 1917 Count (as he had now become) Hertling resigned the presidency of the Ministry in order to assume the office of chancellor of the empire. He was succeeded by Herr von Dandl, hitherto chief of the Civil Cabinet of the King.

The imminence of the revolution, a consequence of the discontent excited by the increasing burdens imposed by the war, made itself felt as far back as Jan. 1918 in Bavaria as in the empire. The band of Independent Socialists led by the Social Democratic newspaper editor, Kurt Eisner, did not succeed, it is true, in launching a general strike of munition workers, but there were demonstrations in Nürnberg and Fürth and also in Munich, leading in some cases to street conflicts. Eisner himself and a number of his partisans were arrested and kept in custody with a view to their trial. He was set at liberty only by the political amnesty which the Government of Prince Max



of Baden issued for the whole empire. In the summer and autumn of the year 1918 there were instances of insubordination in one or two Bavarian garrison towns among troops who were being sent off to relieve regiments at the front. Such breaches of discipline indicated opposition to the war in the army and among the population. Eisner was set up by the Independent Socialists in Oct. 1918 as their candidate at a by-election for the Reichstag in the constituency of Munich. At a series of election meetings he advocated the idea of a violent rising of the masses with the object of rapidly ending the war and overthrowing the ruling authorities.

*After the War.*—On Nov. 7 the Social Democratic party and the Independent Socialists organized a mass-meeting on the Theresienwiese, a large park in Munich, in favour of peace; it was attended by about 150,000 workmen and passed off without incident. After the close of the meeting, however, Eisner with his adherents marched through the city, called out the soldiers from the barracks, occupied the guard-house of the royal residence, and formed on the same evening a provisional Workmen's and Soldiers' Council which held its first sitting in the building of the Diet. It sat all night, and a proclamation issued in the early hours of the morning announced the deposition of the dynasty and the conversion of Bavaria into a republic. As the soldiers, with the exception of the officers, were almost unanimously in sympathy with the action of Eisner, and as the working classes and the rural peasantry led by the two Farmers' Leagues, Joseph and Karl Gandorfer, made common cause with him, no serious resistance was offered. The King had left Munich on the evening of Nov. 7 and taken refuge in the castle of Anif in Salzburg. On Nov. 8 the Workmen's and Soldiers' Council in Munich elected a new revolutionary Government with Eisner at its head as Minister-President. Other members of the new Ministry, in addition to Majority and Independent Socialists, were Prof. Jaffé as Minister of Finance and the former Minister von Frauendorfer as Minister of Communications. The new Government issued on Nov. 15 an elaborate programme, and Eisner himself endeavoured by the appointment of the pacifist Prof. Dr. Forster as diplomatic envoy to Berne and by wireless messages to the Allies to promote the conclusion of peace on tolerable conditions. He encountered vigorous opposition in the Bavarian press, including Socialist journals, on account of these proceedings and above all on account of his hostility to the Government of the Commissaries of the People which had just been formed in Berlin. There was a powerful movement in favour of instituting general elections for the Constituent Bavarian National Assembly, but Eisner only yielded to it on Dec. 5. The elections were fixed for Jan. 12 1919. On Jan. 6 1919 the revolutionary Government issued an ordinance setting up a provisional constitution, which conferred upon the Ministry supreme executive powers and a veto upon decisions of the Diet. In the event of the veto's being employed, the vote of the people was to give the final decision. The revolutionary Government was, moreover, to exercise legislative powers until the enactment of a definitive constitution. The elections of Jan. 12 resulted in a powerful displacement of political power towards the Left. The Bavarian People's Party (*Volkspartei*), which had constituted itself on an independent basis as the successor of the Catholic Centre party in Bavaria, won 66 seats, the German People's Party (former National Liberals) and the German Nationalists (old Conservatives) nine seats, the Farmers' League 15 seats, the Democrats 25 seats, and the Social Democrats 62 seats.

The National Assembly was convoked for Feb. 21. Meanwhile the masses had become more and more extremist in the Bavarian capital. There were repeated demonstrations which led to collisions and riots. Although Eisner made great efforts to prevent bloodshed, he could not make up his mind to dissociate himself unequivocally from the extremist elements which were coquetting with Bolshevik ideas. On Feb. 21, when on his way to the Diet in order to inform it of the resignation of the revolutionary Government and to invite it to elect a new

ministry, he was shot dead by Count Arco, a former officer. Before the Assembly could adopt any attitude towards this assassination, it was broken up by the infuriated adherents of Eisner. Men armed with pistols stormed the House and the Social Democratic Minister of the Interior, Auer, who had been wrongly accused of participation in the conspiracy against Eisner, was severely wounded by a shot in the chest, while one deputy and one official were mortally wounded. There followed a period of lawlessness when everyone did as he pleased, since there was no organ of any kind for exercising the sovereign powers of State. The Congress of Councils (Soviets), which met after the assassination of Eisner, arrogated to itself supreme power, and it was only after protracted negotiations between this Congress and the Social Democratic party, which had identified itself with the opposition in the provinces to the usurpation of the Munich Congress, that it was possible to form a new Government. The Social Democratic deputy, Hoffmann, who had been Minister of Education under Eisner, undertook the presidency of the Ministry; the Government was composed of Independent (extreme) and Majority (moderate) Socialists. The National Assembly met for one brief sitting and transferred the power of legislation to the Ministry until law and order could be reestablished. Meanwhile things did not settle down; on the contrary, the situation in the capital became more and more confused. As the Government did not consider that it possessed in Munich the power to carry through its will, it left the city two days before the proclamation of the Councils (Soviet) Republic and betook itself to Northern Bavaria, where it hoped to find support among those sections of the population whose opinions were Democratic. In Munich a dictatorship of a number of extremists, under the influence of Bolsheviks such as Levin and Leviné-Nissen, held sway for four weeks under the name of Councils Republic. The fugitive Socialist Government took up its residence at Bamberg, where the National Assembly also met. With the military support of the Reich, action with Prussian, Württemberg and Bavarian troops was initiated against Munich and culminated in the capture of the capital and the suppression of the extremist insurrection after severe fighting on May 1, 2, and 3.

The final phase of the struggle was characterized by some acts of barbarity, such as the murder of a number of hostages, including a Countess Westarp, in a cellar by the Soviet extremists. Unfortunately in the suppression of the "Red Terror" grave excesses were likewise perpetrated by the other side. There were numerous summary executions and arbitrary arrests, so that in some instances persons who were entirely innocent lost their lives or were put in prison. Northern Bavaria had taken no part whatever in the movement. The Diet remained for the time being at Bamberg. The Government, after the Independent Socialists had left it, was converted into a coalition by the inclusion of two members of the Democratic and two of the Bavarian (Catholic) People's party, with Hoffmann as Minister-President. It submitted to the Diet the draft of a constitution which gave effect to the ideas of parliamentary democracy and which also provided for the exercise of the referendum under certain conditions. A number of other measures for completing the edifice of the democratic State were submitted, and the whole session of the Diet at Bamberg was occupied with the consideration of these. The constitution (see below), the Teachers and Schools law and a number of other important laws were passed. The new constitution bears the date of Aug. 14 1919.

It was only in the late autumn when order had been restored throughout the whole country that the Government and the Diet returned to Munich. In order to prevent the recurrence of a situation like that which had existed under the Councils (Soviet) Republic, the Government had caused so-called *Einwohnerwehren* (volunteer defense forces of the inhabitants) to be formed; in these armed bodies the citizens who took their stand upon the constitution united on a democratic basis for the protection of public order and for the defense of the constitution against popular *emendés*. They elected their own leaders

and endeavoured to act as private organizations without any connexion with regular military bodies. The idea of the *Einwohnerwehren* rapidly took a firm hold, especially among the non-Socialist (*bürgerlich*) section of the population, so that these bands of volunteers developed into a powerful and well-armed volunteer organization. The *Kapp Putsch* which had resulted in a change of Government in the Reich, also produced certain effects in Bavaria. Although the movement did not secure any open adherents there, it brought about a domestic crisis in the course of which the Socialist ministers left the Cabinet. A Provincial Government president, von Kahr, was elected president of the Ministry, and the members of the Cabinet were taken from the adherents of the Bavarian (Catholic) People's party, the Democrats and the Liberal Farmers' League (*Bauernbund*). The elections for the Diet, which took place simultaneously with those for the Reichstag on June 6 1920, exhibited a natural reaction after the hardships which the country had had to suffer from the excesses of the extremist groups during the 18 months following upon the revolution; there was a great increase in the strength of the non-Socialist (*bürgerlich*) parties. Only 27 Social Democrats, 22 members of the Independent Socialist party and two Communists were elected, while on the other hand 108 members of the non-Socialist parties were returned. Among the latter the Democrats had, however, lost many seats to the German Nationalists (the old Conservatives) and to the German People's party (the old National Liberals). Herr von Kahr was again entrusted with the formation of a Cabinet; he selected one Farmers' Leaguer, one German Nationalist (Conservative) and one Democrat, and filled the other ministerial posts with members of the Bavarian People's party and with officials who were in sympathy with that party. He received powerful support from a party organization in the country which was the rival of the Farmers' League, the Catholic Peasants' Union (*Bauernverein*), at the head of which was the gifted and popular Dr. Heim, who has been called "the uncrowned King of Bavaria." On the whole the country remained free from domestic disturbances. On the other hand the necessity of disarming and disbanding the *Einwohnerwehren* in accordance with the Treaty of Versailles led to protracted and difficult negotiations with the Government of the Reich and to an exceedingly critical situation for the Kahr Ministry in Bavaria itself, as that Ministry had made the maintenance of the *Einwohnerwehren* one of the principal planks in its platform.

In consequence of the ultimatum of the Allied Powers the situation with regard to the disarmament of the *Einwohnerwehren* became acute as between the Reich and Bavaria in May 1921. Direct diplomatic representations were made to the Bavarian Government; for France, in spite of a provision in the new constitution of the Reich (Art. 78), had accredited a minister to Bavaria, while Great Britain had ultimately sent a diplomatic consul. Herr von Kahr was finally constrained to announce that in agreement with the leaders of the *Einwohnerwehr* the Bavarian Government were prepared to make the sacrifice of disarmament. The Government had previously been vigorously pressed in this sense by the Opposition and in particular by the Independent Socialists. Their leader, Gareis, an able young man in his thirty-second year, was assassinated, doubtless by the hand of a reactionary, on his way home from a meeting on the evening of June 9 1921, an event which once more threatened to arouse the insurrectionary fury of the industrial masses.

Altogether the position of Bavaria within the Reich remained in many respects a source of perplexity in 1921. Much would depend upon the degree of success with which the Central Government (of the Reich) in Berlin might be able to grapple with problems of home, and more especially of foreign policy in carrying out the provisions of the Treaty of Versailles.

(O. S.)

*The New Constitution.*—During the night between Nov. 7 and Nov. 8 1918, before the imperial régime had been overthrown in Berlin (Nov. 9), the revolution broke out at Munich,

The House of Wittelsbach was expelled. The Independent Socialist, Kurt Eisner, one of the most remarkable personalities of the revolution, put himself at the head of the revolutionary Government. It was contemplated that a newly elected Diet (*Landtag*) should provide the new republic of Bavaria with a basis of legality by means of a constitution. The electoral regulations issued with this object on Dec. 9 1918 conferred the franchise upon all Bavarians, without distinction of sex, who had reached their twentieth year. In order, however, to safeguard the results of the revolution Eisner's Government promulgated before the elections for the Diet a provisional fundamental law of the State for the "Socialist Republic of Bavaria," and this fundamental law provided for the establishment of parliamentary Government. The Diet was to have met on Feb. 21 1919. On that day Eisner was assassinated; the disorders which followed prevented the Diet from taking in hand at once the preparation of the definitive constitution. What the Diet adopted in the first instance was once more a provisional "Fundamental Law of the State," which corresponded in essentials with the first provisional law and came into force on April 2 1919. Thereafter the fresh revolution of the Communists, which had been threatening since the assassination of Eisner, broke out. Under the leadership of Russian Bolsheviks, the "Councils Republic" of Bavaria was set up. By May 1 the domination of the Communists was again at an end. The Diet could reassemble, though, at first, not in Munich, On May 28 1919, the draft of the text of a constitution for the "Free State of Bavaria" was submitted to the Diet by the Hoffmann Ministry. After detailed consideration the Constitution was voted and came into force on Aug. 14 1919.

The constitution starts from the assumption that Bavaria continues to be a state within the German Reich, although it has had to cede a great part of its former rights to the Reich. This conception was still more strongly emphasized in Eisner's provisional "Fundamental Law of the State" than in the constitution which was finally adopted; for Eisner's fundamental law was headed by the declaration, "Bavaria is a member of the United States of Germany (the German Reich)." Eisner indeed vigorously defended the conception of federalism in opposition to the view that Germany had by the revolution become a single, united state (*Einheitsstaat*). On the publication of the first draft of the constitution of the Reich, which was essentially unitarist, Eisner brought about a conference of representatives of the German states, at which the South German states succeeded in securing the institution of a permanent "Committee of the States." This committee or delegation cooperated in the legislation which followed, particularly in the preparation of the new constitution of the Reich. The *Reichsrat*, the federative organ of the Reich, originated in this committee. It is true that Bavaria, notwithstanding its resistance, had not only to give up its "Reserved Rights," but also to acquiesce in considerable limitations of its independence. It had to cede to the Reich the control of foreign policy, of the army and of communications, in particular the railways; it may not maintain in foreign countries either legations or consulates of its own. It has also been subjected to considerable restrictions in its economic policy by the Reich, as economic legislation falls within the competence of the latter, while the finance legislation of the Reich has appropriated almost all the sources of taxation. All the greater were the efforts made in the Bavarian constitution to give effect in its provisions to the residue of sovereignty which has been left to the territories (the Free States) in the Reich. It goes so far in this regard that some of its provisions can scarcely be brought into harmony with the constitution of the Reich. The form of the State is prescribed for the territories by the constitution of the Reich.

Bavaria accordingly is, like the Reich, a "Free State" (republic). The powers of the State (sovereignty) proceed from the people. It is in the Parliament, the Diet (*Landtag*), that the powers of the State are actually vested. Bavaria is thus, like the Reich, a "representative democracy," but it is a democracy without "the separation of the powers"; for it does not possess an organ for the executive with rights equal to those of the Diet—a president. The ministry is appointed by the Diet and is answerable to it; a minister must at once resign when the Diet expresses its want of confidence in him. The rights of the Diet are, however, limited by the fact that it is left open to the people itself to exercise the powers of the State directly. This may take place if, by a "demand of the people" (the initiative), the popular decision (*Volksentscheidung*) regarding a law or regarding the dissolution of the Diet is brought into action. In order to bring about a decision of this character, a formal pro-

<sup>1</sup> *Reservrechte*, which were secured for it under the constitution of the Hohenzollern Empire.

posal, which must have been supported by at least one-tenth of the citizens possessing the franchise, is requisite. If it be a case of an alteration of the constitution or of the dissolution of the Diet, the support of one-fifth of the electorate is required. This right of direct cooperation by the people is intended to be a substitute for the "balance of powers" which is lacking in the constitution. To this extent the Bavarian constitution, as indeed the constitutions of the other German territories and that of the Reich, contains an element which signifies "direct democracy."

The Diet consists of a single Chamber. There is no Upper House. All men and women who have completed their twentieth year have the franchise. They elect the deputies by secret ballot on the basis of proportional representation, arranged so that there is a deputy for every 40,000 inhabitants. The details of electoral procedure are fixed by a separate electoral law. Only citizens of Bavaria who have completed their twenty-fifth year are eligible.

The ministry is appointed by the Diet in the following manner. First the minister-president is elected. He submits a list of the candidates whom he proposes for the other ministerial posts, and the ministers are appointed with the assent of the Diet. It is not requisite that ministers should be members of the Diet. The real organ of the executive is the ministry as a whole, but it is at the same time, as follows from what has been said, dependent upon the Diet. The ministry adopts its decisions by majority. The minister-president presides over the whole ministry and has a casting vote when the voting is equally divided. The ministry distributes the affairs of the state among the different ministerial departments and makes the appointments to the most important administrative posts. It issues general ordinances for the conduct of administration and decides upon the legislative measures which are to be submitted in the name of the Government to the Diet. If a minister in the exercise of his office has designedly or by gross negligence infringed the constitution or one of the laws, he may be impeached by resolution of the Diet before the Court of Jurisdiction in State Affairs (*Staatsgerichtshof*). The penalty for ministers who are found guilty is dismissal from office. The majority of the Court of Jurisdiction in State Affairs consists of members of the Diet; the minority is composed of official judges.

Legislation is conducted in the following manner: The Diet votes upon the bills which are initiated among its own members or are laid before it by the popular initiative (*Volksbegehren*). An appeal to the popular decision (*Volksentscheidung*), or referendum, on a legislative measure arises (1) when the Diet rejects a popular demand (*Volksbegehren*) for the enactment of a law; or (2) when the Diet passes a law without a popular demand for it having been presented, and when thereupon an appeal is made to the popular decision (*Volksentscheidung*) either in consequence of a resolution of the ministry or in consequence of a popular demand (*Volksbegehren*) for the referendum. There is, however, an important class of laws which are exempt from the referendum, in particular laws relating to the budget or relating to taxes or excise duties, and laws dealing with the salaries of officials. There is likewise no referendum in the case of a law which the Diet has declared to be urgent.

The estimates are annually fixed by the Diet by legislation. But, in order to preclude needless finance on the part of the ministry, the constitution prescribes that, on the demand of the ministry, there shall be a second reading of those financial resolutions which have the effect of increasing the amount of the items or of introducing fresh items of expenditure. At the second time of voting such resolutions a majority of two-thirds of the members present is requisite. Once the measure is voted, it is dispatched by the president of the Diet and the whole ministry, and is promulgated. (W. v. B.)

**BAZIN, RENÉ** (1853- ), French novelist and man of letters (*see* 3,561), produced two further novels, *Davidée Birot* (1912) and *Gingolph abandonné* (1914), as well as a volume of travel sketches, *Nord-Sud Amérique, etc.* (1913) in the pre-war period. After 1914 he published two volumes of war sketches, *Pages religieuses* (1915) and *Aujourd'hui et demain* (1916), as well as two novels, *La Closerie de Champdolent* (1917) and *Les nouveaux Oberlé* (1919).

**BEACH, REX** (1877- ), American writer, was born at Atwood, Mich., Sept. 1 1877. He was educated at Rollins College, Fla. (1891-6), the Chicago College of Law (1896-7), and Kent College of Law, Chicago (1899-1900).

His tales of adventure include *Pardners* (1905); *The Spoilers* (1906, also dramatized); *The Barrier* (1907); *The Silver Horde* (1909); *Going Some* (1910, also dramatized); *The Ne'er-do-Well* (1911); *The Net* (1912); *The Iron Trail* (1913); *The Auction Block* (1914); *Heart of the Sunset* (1915); *Rainbow's End* (1916); *The Crimson Gardenia*, and *Other Tales of Adventure* (1916); *Laughing Bill Hyde and Other Stories* (1917); *Too Fat to Fight* (1919); *Oh, Shooll* (1921).

**BEATTY, DAVID BEATTY, 1ST EARL** (1871- ), British admiral, was born in Ireland in 1871, the son of Capt. D. L. Beatty, 4th Hussars, of Borodale. He was not, as so many naval officers are, predestined to his profession by family asso-

ciation or tradition, which in his case took its tone chiefly from the army and the hunting-field; his father was a well-known figure in the Leicestershire world of the 'eighties and 'nineties. That David alone of the family went into the navy was largely a matter of accident, and his own choice at the age of 13, when he was sent to the Royal Naval Academy at Gosport, can certainly have had little to do with it. Yet within 35 years of that date he had run through the whole gamut of naval possibilities, including those attained only rarely by naval men of any age—Commander-in-Chief of the Grand Fleet, Admiral-of-the-Fleet, and First Sea Lord—to say nothing of an earldom, the thanks of Parliament, the O.M., and the Lord Rectorship of Edinburgh University. His sea service combined the maximum of variety with a minimum of mere routine. As midshipman he served in the Mediterranean flagship "Alexandra" and with the training squadron in the "Ruby." He was sub-lieutenant in the "Nile" and the yacht "Victoria and Albert." His six years of service as lieutenant were passed in the "Ruby," "Camperdown" and "Trafalgar"; in the Portsmouth destroyer flotilla, and in the Nile gunboats. His service there and in the battles of Atbara and Omdurman won him his commandership, and in that rank he served in the "Barfleur." The Boxer rising gave him another opportunity of active service; he was wounded while in command of a shore party, when his dash and leadership won him further promotion, and he became captain at the record age of twenty-nine. From 1900 to 1910 he was in command successively of the cruisers "Juno," "Arrogant" and "Suffolk," and the battleship "Queen." In the naval manoeuvres of 1912 he flew in the "Aboukir" his flag as rear-admiral, a rank which he had attained 24 years from the day the boy of 13 had entered Gosport Academy.

Even up to this point his career establishes a record in the history of the navy. It was, in a sense, so far as the navy was concerned, an obscure career, unhelped by "influence," unknown to the public, undistinguished by the kind of fame attained by the passing of examinations. It was remarkable only by its brilliant rapidity. What he had done he had done by himself, and he had come under no personal influence, with the possible exception of that of Lord Kitchener as Sirdar, that had particularly inspired or moulded him. He was never at the top of any of the lists of his rank, but generally near the bottom, from which he would leap, by sheer merit of service, to a similar humble position at the bottom of the next list, thus passing on the ladder hosts of officers who were laboriously climbing by the routine of seniority and the death or promotion of those above them. To make legal his promotion to flag rank in 1910 a special Order in Council had to be passed, as he had not served the statutory time in command of a ship at sea. His two Admiralty appointments afforded him brief but valuable experience. While still a captain he had acted for about a year as naval adviser to the War Council; and under Mr. Churchill he became naval secretary to the First Lord. In this capacity he assisted at the conference held at Malta in 1912 when the decision was made to reconstitute the Mediterranean fleet by replacing the older battleships by a smaller but more modern force of battle cruisers. In 1913 he was appointed to the command of the First Battle Cruiser Squadron, the fastest and most powerful scouting force ever launched, and hoisted his flag in the "Lion" (March 1).

From this brief outline of his service career it will be observed that Beatty escaped two things. By seizing every opportunity for fighting service he avoided that long period of drudgery in big ships which had for some time been recognized as having a deadening effect on the fighting spirit and initiative of naval officers. Similarly he was equally successful in avoiding long periods of shore service at the Admiralty which, valuable as they may be as a training in administrative work, do not tend to develop the entirely different set of qualities demanded of an officer in high command afloat in time of war. Of administrative work in the large sense Beatty had practically no experience at all when he hoisted his flag in the "Lion" and pro-

ceeded to train the newly formed squadron. In some ways it was an advantage. He came to this vital task with an original and untrammelled view of its essential objects, with an instinct for warfare developed in actual fighting, and with a mind undulled by subservience to that long grind of routine which is the inevitable avenue to flag rank except for the fortunate few who, like him, can gain early promotion for fighting services. Throughout his career, when Beatty was given the choice of decoration or other distinction as a reward for such service, he always chose promotion. He had an instinctive certainty that war with Germany would come in his time; and in so far as it lay in his power to shape his career, he shaped it so that he should be in a position to take a leading hand when the hour struck. As it was, with all the brilliant rapidity of his advancement, the war came just a little too soon to give him at the outset, and at the most vital moment, the position of commander-in-chief, which no doubt would have come to him almost as a matter of course if he had had a little longer in which to prove his undoubted qualifications for that post. When he did succeed to it the pioneer work of fleet organization had been done by Sir John Jellicoe, and the policy governing the use of the Grand Fleet as a strategic weapon had been, for good or ill, definitely established.

When the World War broke out, Beatty, although long marked by an intelligent few as certain to achieve distinction, was practically unknown to the navy at large. The routine Home fleet service in which officers get to know each other intimately had claimed little of his time; and when he took command of the battle cruisers even Lord Fisher had never met him. But a very few weeks of war service revealed his quality as a leader. In the action of the Heligoland Bight (Aug. 28 1914), a reconnaissance of light craft in which the battle cruisers were acting in support of Commodores Keyes and Tyrwhitt, Sir David Beatty exhibited his remarkable instinct for being at the right place at the right moment. Partly owing to faulty Admiralty dispositions the British light craft, after the first object of the action had been achieved, were in danger of being cut off when Adml. Beatty, acting not so much on information as on his intuitive sense of the position, turned back through a submarine-infested area and arrived just in time to save them and sink every German ship in the immediate neighbourhood. Then and throughout the war his battle cruisers were the spearhead of the British naval forces. In a score of operations of which, as they did not result in contact with the enemy, history takes no note, and in the two which developed into fleet actions, Beatty, in his famous flagship the "Lion," was the leading spirit and pivot of the fighting forces. A true disciple of Nelson, he was a rebel against the official conception of British strategy that, provided the enemy were properly contained, his destruction was a kind of luxury that might be indulged in only on condition that the containing force was not unduly risked. Beatty, on the other hand, was inspired with the spirit of attack. He had unique qualities as a leader which made men willing to follow him anywhere, and to achieve the impossible; but apart from his dash and courage he showed consummate skill and caution in dealing with the new hidden elements which have placed so great a power in the hands of the defensive in modern naval warfare. At the battle of the Dogger Bank (Jan. 24 1915) he chased the enemy for three hours, inflicting such severe punishment that the "Blücher" was sunk and the "Scydlitz" and "Derfflinger" and "Moltke" were in full flight, the two former in a battered condition, when the "Lion," which as head of the pursuing line had received heavy punishment, was put out of action, and the command devolved on Rear-Adml. Sir Archibald Moore. This officer, whose flag was flying in the "New Zealand," gave no orders during the vital 40 minutes following the "Lion's" disablement. Adml. Beatty's signals to "keep nearer to the enemy" were either missed or misunderstood by the ships immediately following him, with the result that touch with the German battle cruisers was lost, and what was on the point of becoming a complete victory was left merely as an

indecisive castigation of the enemy. The facts of this action, which had not been officially made public up to the spring of 1921, were first given at that date in Mr. Filson Young's *With the Battle Cruisers*, containing a very full account of the battle, with track charts and the actual text and times of the signals made.<sup>1</sup>

Beatty's brilliant handling of the battle cruisers in the battle of Jutland is discussed in the article on that action (*SEE JUTLAND, BATTLE OF*). Some months later (Dec. 1916) he succeeded Sir John Jellicoe as Commander-in-Chief of the Grand Fleet, in which capacity he received the surrender of the German fleet on Nov. 21 1918. He was raised to the peerage in 1919 as Earl Beatty, Visct. Borodale of Borodale, Baron Beatty of the North Sea, receiving the thanks of Parliament and £100,000. At the same time he was awarded the G.C.B., the O.M. and other honours and decorations. In 1919 he became First Sea Lord, and immediately set in motion measures for a reorganization of the naval staff on lines which would give the younger school of naval thought and experience a chance to make itself felt. He attended at Washington, D.C., in 1921 the Conference on the Limitation of Armament.

The following estimate of Lord Beatty was given, in the book referred to, by Mr. Filson Young, who had served on his staff in the "Lion."

"One who has served him and observed him closely in the stress of war may at least bear this testimony to his conduct in the chapter of his life which is already over: that in everything that he did or attempted he showed forth in himself and evoked in others the fighting spirit that made England invincible in the past. The common view of him as a dashing leader trusting largely to luck, which so much endears a man to the ordinary English mind, is singularly untrue. It was not the mere instinct of the hunting-field, strong as it was in him, that brought him to the head of the Navy. His caution and his sense of responsibility were just as remarkable as his enterprise; but they were never allowed to obscure or dominate the fighting spirit. Perhaps the greatest tribute one can pay to him and to the Navy is to say that in the qualities in which he proved supreme he was not exceptional, but typical; and it was because he was a product of the modern Navy and contained in himself all its most characteristic qualities, that the Navy would have trusted and followed him anywhere."

Lord Beatty married in 1901 Ethel, daughter of Marshall Field, sen., of Chicago; of his two sons the elder, Viscount Borodale, was in 1921 a cadet in the Royal Navy. (F. Y.)

**BEAUCHAMP, WILLIAM LYGON, 7TH EARL (1872- )**, English politician, was born in London Feb. 20 1872, the eldest son of the 6th earl. He was educated at Eton and Christ Church, Oxford, and afterwards entered public life as a Liberal. In 1891 he succeeded his father in the title. He was mayor of Worcester from 1895 to 1896, and in 1897 became a member of the London School Board. In 1899 he was appointed governor of N.S.W., but in 1901 returned to England. In 1907 he became lord steward of the royal household, and in 1910 entered Mr. Asquith's Cabinet as first commissioner of works and lord president of the council, retaining the latter post on the reconstruction of the Government in 1914. He received the Order of the Garter in 1914, and retired in 1915. Lord Beauchamp was from 1906 to 1907 captain of the Honourable Corps of Gentlemen-at-Arms, and in 1913 was made lord warden of the Cinque Ports. He married in 1902 Lady Lettice Grosvenor, daughter of Earl Grosvenor and sister of the 2nd Duke of Westminster.

**BEAVERBROOK, WILLIAM MAXWELL AITKEN, 1ST BARON (1879- )**, British politician, was born at Newcastle, New Brunswick, on May 25 1879, the son of the Rev. William Aitken, Presbyterian minister of Newcastle. He was educated at Newcastle, and afterwards went into business, where he had a very successful career as a financier. Having made

<sup>1</sup> The Financial Secretary to the Admiralty answered in the affirmative a question asked in the House of Commons on May 4 1921 by Visct. Curzon as to whether the account given in this book might be taken as correct. Its publication then relieved Adml. Beatty of any responsibility for the somewhat misleading version originally issued by the Admiralty of his own dispatch after the battle.

a large fortune at a comparatively early age, he came to England in 1910, and stood successfully for the House of Commons as Unionist candidate for Ashton-under-Lyne. He was from the first an intimate friend and adviser of Mr. Bonar Law when the latter became the Unionist leader. In 1911 he was knighted. In 1915 he went to France with the Canadian expeditionary force as "Eye-Witness," and in 1916 became the representative of the Canadian Government at the front, also doing valuable propaganda work. He was created a baronet in June 1916, and the same year was raised to the peerage. In 1917 he was appointed officer in charge of the Canadian war records, and in 1918 entered the Government as Chancellor of the Duchy of Lancaster in succession to Lord Cawley and director of the Ministry of Information in succession to Sir Edward Carson, but resigned in Oct. of the same year. Lord Beaverbrook became one of the chief proprietors of the *London Daily Express*, and in 1916-7 published *Canada in Flanders*.

**BEBEL, FERDINAND AUGUST** (1840-1913), German socialist (see 3.601). During Bebel's last years his views regarding the revision of the Social Democratic programme underwent a considerable change; he ultimately favoured revision in the sense of coöperation with non-Socialist political parties in democratic reforms. In the Reichstag he continued to oppose with great energy the world-policy and the naval expansion with which William II. and his successive chancellors were identified. At the same time he guarded himself against the reproach of favouring a policy of non-resistance to foreign aggression, and on one occasion declared that he would be the first to shoulder his rifle if Germany were invaded. His attitude towards imperial and autocratic Russia was throughout uncompromising. He denounced the complaisance of Prince Bülow's Government towards the Russian Government in respect of the treatment of Russian political refugees, and it would hardly be too much to say that he would have welcomed a rupture with Russia on almost any ground. His influence in this regard powerfully contributed to foster those sentiments in the Social Democratic party which led it, a year after his death, to acclaim the declaration of war against Russia on Aug. 1 1914. In internal affairs he particularly distinguished himself by his denunciation of the maltreatment of soldiers by officers and still more frequently by non-commissioned officers. His efforts in this matter had received great encouragement when Albert of Saxony (1828-1902) issued an edict dealing with the maltreatment of soldiers in the Saxon contingent, thus cutting the ground from under the feet of the Imperial Government, which had persistently attempted to deny or to explain away the cases adduced by Bebel. Bebel had amassed a fortune—some £30,000, it is said—from the proceeds of his writings, and this was increased by a legacy of some £20,000 left him, curiously enough, by an officer who had profited by his advice in a disciplinary case in which the officer had once been involved. He owned a villa on the Lake of Zürich where in later life he spent a great part of the year. One of his last public appearances was at an International Peace Conference at Bern in 1913. He died at a sanatorium at Passuggin, Switzerland, on Aug. 13 1913.

**BECK, FRIEDRICH, COUNT** (1830-1920), Austrian general, was born at Freiburg im Breisgau, and entered the army in 1848. He distinguished himself as chief-of-staff of an infantry division at Magenta, and in 1863 was made personal aide-de-camp to the Emperor. He held this position, with that of adjutant-general and chief of the imperial military chancery until 1882, winning the Emperor's confidence and exercising the greatest influence on all military questions. In 1866 he acted as the Emperor's confidential agent at the headquarters of Field-Marshal Benedek, before and after the battle of Königgrätz, and his advice was of great importance, though it was not always followed. In 1878 he was entrusted with a similar mission to the commander-in-chief of the troops operating in Bosnia. In 1882 he was made chief of the general staff of the Imperial and Royal army, an exalted position which he occupied till 1906. Not only was his advice listened to in military affairs,

but he frequently exercised great influence on important political and personal questions, gaining a great reputation throughout the monarchy as one of its most influential men. His clear judgment and practical common-sense enabled him to see and judge men and things from a purely objective standpoint. He was retired at the age of 77, with every possible sign of honour, and was appointed commander of the Imperial Guard. He took no part in the World War, and died in Feb. 1920. (A. K.)

**BECKWITH, J (AMES) CARROLL** (1852-1917), American portrait painter (see 3.610\*). He exhibited at St. Louis in 1904 "The Nautilus" and a portrait of Mrs. Beckwith. Yale, Johns Hopkins, and West Point possess examples of his works, and the New York Public Library has a collection of his crayon and pencil drawings. He died in New York, Oct. 24 1917.

**BEECHAM, SIR THOMAS, 2ND BART.** (1879- ), English musical conductor, was born April 29 1879, son of Sir Joseph Beecham, 1st bart. (1848-1916), who had made a large fortune at St. Helens, Lancs., as proprietor of "Beecham's Pills." Young Beecham was educated at Rossall and for a time at Wadham College, Oxford. His father was keenly interested in music and had given financial support to a number of musical enterprises in the North of England; where the son acquired considerable experience as a conductor. In 1905 he gave his first concert in London with the Queen's Hall orchestra. A little later he founded first the New Symphony orchestra and next the Beecham orchestra, both first-rate concerns. In 1909 he appeared in London as opera conductor, and in Feb. of the following year the Beecham Opera Co., consisting entirely of English-speaking singers, was inaugurated. The season was started at Covent Garden in the following year when among other operas produced for the first time in London were Strauss's *Elektra* (Feb. 1910), Delius's *Romeo and Juliet in the Village* and Debussy's *L'Enfant Prodigue*. In the same year there was a further season at His Majesty's theatre during which Strauss's *Feuersnot* was given, its London première. Further London seasons followed in later years, all with decided artistic success. These led up to the great climax when in 1913 the Beecham season of opera and ballet at Covent Garden included the production of Strauss's *Rosenkavalier* and *The Legend of Joseph*. Later in the same year there was a magnificent season at Drury Lane of Russian opera and ballet, made famous not only by the splendour of the productions of Russian opera in the vernacular, which in all probability would never otherwise have been heard in London, but by the remarkable singing and still more remarkable acting of Shaliapin, who then made his first appearance in England. During the second and third years of the World War there were Beecham seasons of opera at the Shaftesbury and Aldwych theatres, when pronounced success was achieved by performances of *Valkyrie* and *Tristan and Isolde* sung in English. Beecham's own version of Bach's cantata *Phoebus and Pan* was given at the latter theatre. In 1917 the Beecham Opera Co. were once more at Drury Lane, and in 1920 Beecham organized a somewhat ill-starred cosmopolitan "grand" season at Covent Garden, during which Puccini's so-called triptych, *Il Tabarro*, *Swor Angelica* and *Gianni Schicchi*, was given for the first time in Great Britain. From 1915 to 1918 Beecham was conductor of the Royal Philharmonic Society, whose very existence during the World War he practically guaranteed. In 1916 he was knighted, and shortly afterwards he succeeded to his father's baronetcy. The lavish expenditure of his private fortune upon opera in English ultimately led to financial embarrassments which in 1920-1 necessitated the suspension of his musical activities.

**BEECHING, HENRY CHARLES** (1859-1919), English divine and author (see 3.640), who was appointed dean of Norwich in 1911, died at Norwich Feb. 25 1919.

**BEERBOHM, MAX** (1872- ), English writer and caricaturist, was born in London Aug. 24 1872, the son of Julius Beerbohm and Eliza Draper, and half-brother of the actor, Sir Herbert Beerbohm Tree. He was educated at Charterhouse and Merton College, Oxford, and afterwards became well known as a contributor to the *Yellow Book* and dramatic

\* These figures indicate the volume and page number of the previous article.

critic on the *Saturday Review*. He married in 1910 Miss Florence Kahn, of Memphis, Tennessee, and afterwards took up his residence at Rapallo, Italy. His published writings include *The Works of Max Beerbohm*, containing the famous essay on George IV., and also *A Defence of Cosmetics* (1896); *The Happy Hypocrite* (1897); *More* (1899); *Zuleika Dobson* (1911); *A Christmas Garland* (1912); *Seven Men* (1919), and *And Eons Now* (1920). He also contributed to and edited the *Life of Sir Herbert Beerbohm Tree*, published in 1920. He is well known by his caricatures, of which exhibitions have been held in London at the Carfax Gallery (1906) and the Leicester Galleries (1911, 1913, 1921). In 1917, a Modern Loan Exhibition at the Grosvenor Galleries included a group of 15 caricatures entitled "Rossetti and His Friends." Many of his caricatures have been published in *Caricatures of Twenty-five Centuries* (1896); *The Second Childhood of John Bull* (1901); *The Poets' Corner* (1904); *A Book of Caricatures* (1907); *Fifty Caricatures* (1913). His delicate and incisive satire has found its best material in the peculiarities of individuals in every section of society. Movements he almost invariably typifies by some well-known personality. Pledged to no party, his friends have occasioned some of his most characteristic work, notably the series dealing with the New English Art Club and with Mr. Balfour. Like Forain and Steinlein in his detachment, he lacks their universality; and complete appreciation of his art implies an intimate knowledge of current affairs. As a draughtsman he is not faultless, and sometimes resorts to the veriest conventions; but his freedom of line, feeling for delicate colour and sense of design are remarkable, especially in his later work. (W. G. C.)

**BEERE, MRS. BERNARD** [FANNY MARV] (1856-1915), English actress, was born at Norwich Oct. 5 1856. She was the daughter of Wilby Whitehead and was trained for the stage by Herman Vezin, appearing first in the Opéra Comique, London, in 1877. Later she played Emilia in *Othello* and various old English comedy parts at the St. James's theatre. In 1883 she was engaged by the Bancrofts to play leading parts in *Pedora* and other dramas at the Haymarket. In 1891 she played Lady Teazle in Charles Wyndham's production of *School for Scandal*, and two years later Mrs. Arbuthnot with Herbert Tree in Oscar Wilde's *A Woman of No Importance*. She was three times married, but for stage purposes retained the name of her second husband. In 1900 she married Mr. A. C. S. Olivier. She died in London March 25 1915.

**BEESELY, EDWARD SPENCER** (1831-1915), English positivist (see 3.644), died at St. Leonards-on-Sea July 7 1915.

**BEGAS, REINHOLD** (1831-1911), German sculptor (see 3.652), died Aug. 3 1911.

**BEHAVIOURISM**.—In the earlier article on **INSTINCT** (see 14.648) and also, though perhaps less obviously, in that on **INTELLIGENCE IN ANIMALS** (see 14.686), the stress was laid on behaviour. In later years attention has been turned more and more to what has become known in this connexion as "behaviourism." What then is behaviourism? It has features in common with pragmatism and with neo-realism. It is however (as is the case with these other 'isms) somewhat difficult to define. If we seek to elicit from the writings of this or that behaviourist a clear statement of the doctrine he champions or accepts, we find not a little divergence of opinion. And perhaps each would remind us that J. J. Thomson has spoken of science as a policy rather than a creed. What then is their common policy? One may reply without much fear of misinterpreting their aim: A resolute application of radical empiricism in the scientific interpretation of all behaviour and conduct.

In this interpretation a good deal turns on the relation of behaviour to consciousness, in some sense of this word. "Critics of behaviourism," says Weiss (1918), "do not recognize clearly enough that the term 'consciousness' varies in its meaning with nearly every person who uses it. There is no generally accepted definition or description; and the fact that psychologists and philosophers have been unable to reach an agreement is one of the conditions which has precipitated behaviourism." As to behaviourists themselves he tells us that, thus far, they have

agreed that the most convenient procedure is not to use it at all. It needs, however, but little acquaintance with their writings to realize that, so far is this from being a matter of common agreement among them, there is much discussion of the sense in which the adjective "conscious" as applied to behaviour is to be understood. Here again opinions differ. But let us put the question in a rather different form. Let us ask: In what sense is the word "consciousness" to be rejected by every behaviourist? As to the answer to this question there is a far larger measure of agreement.

In 1904 William James asked the question: Does consciousness exist? His reply was that it does not exist as an hypostatized entity with the unique privilege of activity, but that it does exist as a function. In its negative aspect his answer excludes "the hypothesis of trans-empirical reality," i.e. that from which proceeds what is sometimes spoken of as "an alien influx into nature." The transcendental *Ego* of the philosophies, he urges, shows how "the spiritual principle attenuates itself to a thoroughly ghostly condition." And he says roundly: "I believe that 'consciousness,' when once it has evaporated to this estate of pure diaphanicy, is on the point of disappearing altogether. Those who still cling to it are clinging to a mere echo, the faint murmur left behind by the disappearing 'soul' upon the air of philosophy." There is no activity of consciousness in this sense. "The healthy thing for philosophy is to leave off grubbing underground (in the realm of the trans-empirical) for what effects effectuation or what makes action act." Activity in an empirical sense there is in plenty. It is change in progress referred to some "storm-centre" of change. It is change intrinsic to some system and not merely imposed upon it from without. But there is for scientific treatment no activity of a trans-empirical entity which may be regarded as the source of such change. When therefore a behaviourist says that "we need a psychology of human conduct to supplant the psychology of consciousness" (G. A. Tawney 1911), that which he seeks to supplant is a psychology which invokes what James spoke of as trans-empirical agency. It is probably not going too far to say that this marks a distinctive feature of behaviourist interpretation.

It should here be added that though this may with some confidence be said to be a distinctive feature of behaviourist interpretation it does not follow that if this be accepted one may infer that a writer who accepts it is to be ranked as a behaviourist. It is, for example, fully endorsed by Howard C. Warren in his *Human Psychology* (1920). But he says: "The behaviourist contends that the data of consciousness should be ruled out of science altogether because they are not causal factors. This narrowing of the scope of science has not justified itself up to the present. Self-observation has proved more useful than the study of behaviour in investigating the phenomena of human mental life." It is questionable, however, whether all who label themselves behaviourists do contend that the data of consciousness should be ruled out altogether. R. M. Yerkes would not agree that this is so in animal psychology. And E. B. Holt, though he sails under the behaviourist flag in his *Freudian Wish*, assuredly does not rule out consciousness.

Let us broaden our outlook. If we extend the use of the word "behaviour" so as to include physical events, their modern treatment tends more and more towards behaviourism: "Our sole task," says A. N. Whitehead, "is to exhibit in one system the characters and inter-relations of all that is observed. Our attitude towards nature is purely behaviouristic so far as concerns the formulation of physical concepts." His attitude towards organic events and their mental concomitants may be different. But his rejection of any "bifurcation of nature" and his polemic against a doctrine of "psychic additions" (*Concept of Nature*, ch. ii.) is in line with the neo-realistic attitude of those behaviourists who deal with organic life. His percipient event is the homologue of the organism under the treatment of radical behaviourism. Neither the one nor the other stands in need of any "psychic addition" *ad extra* for the adequate interpretation of the facts. Each is set in a field



which for the physicist is a field of acceleration, and for the biologist and psychologist is a field of the environment to which the organism responds *more suo*. The business of science in each case is to formulate an answer to the question: Given such a field, having what may be called varying density, what happens therein? One does not enquire: What makes that which happens so happen? At least one does not ask any such question in a trans-empirical sense. To do so is to "grub underground for what makes action act." But on such terms where does psychology come in? One has here to realize that there are two schools of behaviourists. According to one school the study of conduct is to supplant that of consciousness through so-called methods of introspection. According to the other school such study is to give new value and direction to psychology and thus involves not the abandoning but a redefining of the concept of consciousness. Here alliance is sought with those whom they regard as in spirit, if not in name, one with them in aim. Behaviourists of this latter school, while still rejecting consciousness as a trans-empirical agent, and thus avoiding all taint of animistic interpretation, all interaction of mind and body as disparate entities, all so-called parallelism and the like, none the less accept consciousness as an empirical function. What does this mean? It is connected with what is spoken of as the relational view of consciousness, and thus has points of contact with the relational view of space-time. Indeed F. J. E. Woodbridge (1905) says that we should use the expression "in consciousness" in a manner like unto that in which we use the expression "in space" or "in time"; and just as we do not ask if space and time, as such, affect things causally, so too we should not raise the question of the causal efficiency of consciousness.

The wedge of entry of the psychic regard, implied by the use of the word "consciousness," is through the concept of awareness. Lotze spoke of one physical body "taking note of" others. Thus the earth takes note of the sun in a gravitative field; iron filings take note of a magnet in an electro-magnetic field. But awareness commonly implies some mental as well as physical taking note of—something, however rudimentary, of the nature of being acquainted with. Now if we speak of a relational field of awareness as one in which this conscious "taking note of" obtains, the organism which is stimulated and responds is always central within that field. If then we call this central term the psycho-organism, it is the locus of consciousness in the sense of being aware. It is the experiencing term in relation to terms in the environment which are experienced. That is one way of regarding consciousness in the widest sense of the word. Consciousness is the class of all instances of experiencing on the part of psycho-organisms. Whitehead's perceptive event, taking note of physically, is also a perceiving event, taking note of psychically. But of course the psycho-organism, as perceiving centre, is that very complexly integrated system of such psychical events which we commonly call a mind.

There is, however, another way of regarding consciousness. Instead of restricting the application of the word to processes of mind<sup>ing</sup> within the perceptive centre, the concept is extended so as to comprise all that is in the field of awareness as mind<sup>ed</sup>. That which one is aware of, no matter how distant its locus of origin may be from the perceptive centre, is "in mind," and therefore "in consciousness," as a relational field. One is, no doubt, conscious *in* seeing, or imaging, or remembering; but one is also conscious of what is seen, imaged, or remembered. And what one is conscious of has every right to be regarded as in consciousness. This distinction between the "in" and the "of" (as here used) goes back at least as far as Berkeley, who spoke of perceiving as in mind "by way of attribute" and of that which is perceived as in mind "by way of idea." We sometimes speak of the former as "in consciousness," and of the latter as "for consciousness"; or of the former as "subjective" and of the latter as "objective." But the behaviourist is, as he might say, "out for" objective treatment. Part of his motive is to show the futility of subjectivism. Hence, for his

treatment, the emphasis falls on that of which one is conscious. Thus E. B. Holt would urge that there is nothing in the subsistent or existent world (for our developed knowledge or our more primitive acquaintance) of which we may not be conscious. For him therefore consciousness is a section through the world of experience, of which section the organism that we speak of as perceiving or conceiving is, in any given particular case, the centre. And Woodbridge (1905) says: "Objects are connected in consciousness in such a way that they become known. It is important to note that, while this is so, the knowledge is wholly determined in its content by the relations of the objects in consciousness to one another, not by the relation of consciousness to the objects."

To be "in consciousness" is thus on this view to be in a field of awareness which may, like space-time, be coextensive with the universe. But this is not the only view—so much turns on definition. Others, without invoking an independent psychic entity, and without denying that there is a widely extensive field of awareness, within which all objects for consciousness are set, would differentiate consciousness as an *imperium in imperio* and restrict it to the organism as the perceptive centre within that field. B. H. Bode (1917) goes further and advocates a yet more restricted concept of consciousness according to which some reference to the future is an essential criterion. "Consciousness is behaviour that is controlled by the future." There is much to be said for the contention that human consciousness is the mental correlate of behaviour that is controlled by anticipations of the future. James urged that with every definite image "goes the sense of its relations, the dying echo of whence it came to us, the dawning sense of whither it is to lead." But this is not quite what Bode says. He speaks of consciousness as "just a future adaption that has been set to work so as to bring about its own realization." This implies that the locus of consciousness, thus regarded, is the perceptive centre. "As Dewey has pointed out, the psychical is correlated with intra-organic adjustments *within* the organism, that is adjustments of the organism considered not with reference to the environment, but with reference to one another." This seems to give to psychology, as commonly understood, a more definite place than is readily to be found in the treatment of Watson. And Yerkes (1917) criticizing the behaviourism of Watson "as simply and solely the physiology of organic activity," claims that there is a science of "psychics" on a par with that of "physics," including in the latter objective physiology and biology. Enough has been said in this connexion to show that it is no easy task to bring to a focus the essentials of behaviourist creed or policy.

Apart from philosophical implications, and apart from its relation, if any, to consciousness, a cardinal feature of this policy is to start out from behaviour as that which lies open to objective observation instead of from introspection, which is supposed to yield some trans-empirical psychic force or energy. Behaviour is the biological "end" of all processes in the organism; it is that which we seek to interpret under the canons of strictly scientific procedure; it is therefore that from which such interpretation should set forth. This, it is urged, has been realized by all the best workers on the problems of animal life; it has been realized in a measure by those who lay stress, in human life, on the importance of conduct. Here the realization needs to be widened and strengthened. Watson would add that it must be formulated in physiological and biological terms. In human life there is no doubt much emphasis on language and on thought. What is language, however, but a subtle mode of behaviour—"laryngeal behaviour" if we include all the contributory bodily processes which centre round oral speech, and, as integrated therewith, the written word? How large a proportion of human behaviour finds its expression in language and its attendant modes of symbolization! But in our adult life much of this has been rendered implicit and no longer gets overt or explicit expression. None the less it is present, as unvoiced "laryngeal behaviour," though "the moment the overt slips into the implicit, instrumentation [the

use of delicate apparatus) becomes necessary to bring the process out for observation" (Watson). Even then it is difficult to interpret the data owing to much abbreviation and short-circuiting.

Now, many who would not care to be labelled behaviourists might provisionally agree that language, expressed or suppressed, is the outcome of thought. But this is not good enough for the physiological behaviourist *par sang*. Language behaviour and thought must be identified. Thus Watson contended that "thought is the action of language mechanisms." It is not, as some assume, "something, no one knows quite what, that can go on in the absence of all muscular activity. It is a constituent part of every adjustment process. . . . It is not different in essence from tennis-playing, swimming, or any other overt activity except that it is hidden from ordinary observation and is more complex and at the same time more abbreviated." If then thought is the action of the laryngeal mechanisms just as swimming is the action of other bodily mechanisms, it clearly follows that thought, for this behaviourist "psychology," in which the word "consciousness" is *taboo*, is a mode of bodily behaviour. In what sense can this be accepted on behaviourist principles? Not without diffidence it may be suggested that to get the answer to this question it is essential to recognize that the organism responds as an integrated whole, and that all that follows on stimulation in some life-situation must be regarded as behaviour. Laryngeal behaviour is the outcome of the behaviour of effectors; their behaviour is the outcome of that of a nervous system with its inherited and acquired neuronc pattern; this behaviour in turn is due to that of many receptors under adequate stimulation. All human conduct, including speech, overt or implicit, is the final expression of the behaviour of the organism, man, as a whole; and this organism is what it is, and finally does what it does as the result of all that has happened to it during development under the environmental conditions of life up to date. Watson seems to lay chief stress on what has been spoken of above as the final expression—the business end of the whole business. And perhaps he would regard what has been said as involving an unwarrantable extension of the concept of behaviour. But there is much, even in his treatment, which lends colour to such an interpretation of that which he would regard as the cardinal policy of behaviourism.

The physiological story above outlined is a familiar one. Watson tells it admirably and adds effective and illuminating touches. He is honest in confessing that much still remains conjectural. One is left in wonder, however, why when the ship of psychology is lightened by throwing consciousness overboard, thought also should not be silently dropped over the stern. Then the vessel thus rendered thoroughly seaworthy might be rechristened and given some more appropriate name under which to pursue her voyage. Psychology seems a misnomer.

The name is, however, retained. So let that pass. Revert to the emphasis on the final expression in act and deed. Here is a bit of sound policy. It is this final expression which is of prime importance in animal behaviour and in human conduct. Herein lies the pragmatic value of behaviourist treatment. Men have, for example, to be selected for vocational work, for service in the social community, as promising for this job or for that, on occasion as likely to be efficient in the army. They must be chosen for what they can do, and do rapidly, surely and well. It is claimed, and there is evidence to substantiate the claim, that the behaviourist with his stress on the effective output in conduct, is able to make a wiser choice than the "orthodox" psychologist who is said to be obsessed with the older intellectualistic methods which involve too much reliance on the methods of introspection only—whose "pure psychology" is of slender value in its application to the current problems of busy life. In another field of practical application it is urged that the methods of behaviourism will be fruitful. Both Watson (1916) and Holt seek to apply them in the procedure of psycho-analysis; and the latter author interprets the *Freudian Wish* in

terms of his special form of behaviourism and his relational treatment of consciousness. One may hazard the opinion that a judicious dose of behaviourist interpretation may serve as a corrective of some of the tenets of what now goes by the name of the New Psychology.

Of late years in England it is instinct in man, rather than in animals, that has occupied the attention of psychologists and sociologists. For this purpose the definition of instinctive behaviour as that which is unlearned—the form of which is not acquired in the course of individual experience, coming by nature and not through nurture—has been found not only difficult of application in human life but scarcely serviceable for marking a contrast which calls for emphasis. Instead therefore of using the word "instinctive" to mark those forms of behaviour which are unlearned and not individually acquired, some use it to distinguish those modes of behaviour which take form unreflectively from those which are the outcome of rational thought under fully deliberate choice. Thus the instincts of the herd, with which W. Trotter has dealt in an able and illuminating manner, are, in part at least, modes of behaviour which have been learnt under the social conditions of gregarious life, which are in large measure due to tradition, and which are only endorsed under the long-familiar process which has of late been called rationalization. Here the bolstering up by some assigned reason is subsequent to the "instinctive" performance of the act. In all this there is nothing which cannot, under appropriate definition, be interpreted on behaviourist principles.

There is, however, another way of dealing with instinct, either in the unlearned or in the not-reflective sense, which will be rejected by most, if not all, behaviourists—may more which is rejected by many of the leading American psychologists and philosophers who would not wish to be regarded as exponents of behaviourism. This is the increasingly prevalent doctrine in England according to which instincts are forces of character, modes of psychic energy, prime movers of human conduct, types of true mental activity, exemplars of genuine impulse, as the rational psychologist and not the physiologist understands this word. It finds able expression in W. McDougall's *Social Psychology*, in A. F. Shand's *Foundations of Character*, and in J. Dreyer's *Instinct in Man*. It is traceable in W. Trotter's *Instincts of the Herd*, in L. T. Hobhouse's *Mind in Evolution*, and in W. H. R. Rivers' *Instinct and the Unconscious*. For those who advocate a new psychology, this seems to be a pivotal concept in the increasing literature of psycho-analysis. Its spiritual father in England is James Ward, whose article *PSYCHOLOGY* in the *E.B.*, 9th Ed., marked a turning-point in thought. It has been fostered through the influence of Henri Bergson. It involves the concept of a "kind of causality so connected with the nature of conative consciousness that it can belong to nothing else" (G. F. Stout, to whose *Manual* an important chapter on Instinct has been added, 1913).

If there is any validity in the characterization of behaviourism outlined above, this is the psychology which its supporters seek to supplant, since it involves, as they aver, a bifurcation of nature through the introduction of trans-empirical concepts. And assuredly those who hold this creed will, on their part, utterly reject behaviourism.

See J. B. Watson, "Psychology as the Behaviourist views it," *Psych. Rev.* xx, 1913 (to this article may probably be assigned the introduction of the word); *Behaviour* (1914); *Psychology from the Standpoint of a Behaviourist* (1920); E. B. Holt, *The Concept of Consciousness* (1914), *The Freudian Wish* (1915). See also *Jour. of Philosophy, Psychology and Scientific Methods* from 1904 to date. The dates in the text after the names of Bode, Weiss, Yerkes and others refer to articles in this journal under the years of publication. W. James's "Does Consciousness Exist?" appeared in the first volume and is reprinted with other pertinent papers in *Essays in Radical Empiricism* (1912). (C. L. M.)

BEILBY, SIR GEORGE THOMAS (1850- ), British physician, was born at Edinburgh Nov. 17 1850, his father being a physician. He was educated at Edinburgh University and trained as a civil engineer. When quite young he developed, in collaboration with the late William Young, a new method

of retorting oil shale, in which by carrying out the operation in two stages, each at the most suitable temperature, most of the fixed nitrogen in the spent shale, which had previously been lost, was obtained as sulphate of ammonia. Between 1881 and 1894 this method entirely displaced the older methods of retorting, and the industry was enabled to hold its own in competition with imported petroleum products. In 1891 Beilby invented and developed a new synthetic process for the manufacture of the cyanides of potassium and sodium, by the use of which gold and silver are recovered from their ores. The cyanides are produced by passing ammonia gas through a molten mixture of the carbonates of the alkalis with charcoal, at a temperature of 850° C. An important British industry was founded on this process, the first factory being opened at Leith in 1891. Beilby was elected F.R.S. in 1906. He was president of the Society of Chemical Industry in 1899, of the chemical section of the British Association in 1905, of the Institute of Chemistry in 1909-12, and of the Institute of Metals in 1916-8. In 1912 he was a member of the Royal Commission on Fuel and Engines for the Navy. During the World War he was a member of the Admiralty Board of Inventions and Research. He was knighted in 1916. He published many scientific and technical papers, and also *The Aggregation and Flow of Solids* (1921).

**BELASCO, DAVID** (1859- ), American playwright and manager, was born at San Francisco, Cal., July 25 1859. After graduating from Lincoln College, Cal., in 1875, he was stage-manager at several theatres and then went to New York where he owned and managed the prosperous Belasco theatre. He wrote or adapted some 200 plays, largely melodramatic, and owing to his mastery of stage-craft he was eminently successful as a producer and stage director. He presented E. H. Sothern in *Lord Chumley* (1887); Mrs. Leslie Carter in *The Heart of Maryland* (1895); Blanche Bates in *Naughty Anthony* (1899); Henrietta Crossman in *Sweet Kitty Bellairs* (1903); and David Warfield in *The Music Master* (1904).

Of his numerous other productions may be mentioned: *May Blossom* (1884); *The Charity Ball* (1887), with H. C. De Mille); *Men and Women* (1890); *The Girl I Left Behind Me* (1893, with Franklin Fyles); *Madame Butterfly* (1900); *Madame Du Barry* (1901); *The Darling of the Gods* (1902, with John Luther Long); *The Girl of the Golden West* (1905); *The Return of Peter Grimm* (1911); *The Governor's Lady* (1912); *The Temperamental Journey* (1913); *The Secret* (1914); *A Celebrated Case* (1915); *The Boomerang* (1915) and *Polly with a Past* (1917).

**BELCHER, JOHN** (1847-1913), English architect, was the son of John Belcher, an architect of some position. He probably derived much of his artistic faculty from his family connexion with William Woollett, the 18th century engraver. Following his father's profession, his education included a couple of years in Germany. He further made a lengthy stay in Paris, studying and sketching modern French architecture, the result of which asserted itself in his first important commission—the Royal Insurance offices in Lombard Street—a French Renaissance building (since pulled down) in which he introduced much sculptured work from the hand of Thomas Thornycroft. Joining his father in the latter's practice John Belcher, Jun., received many commissions, principally, for the next 10 or 15 years, for business premises in the city and elsewhere. Amongst the earliest of these is the well-known block at the corner of Poultry and Queen Victoria Street, a building showing how strongly he was influenced at that period by the Gothic movement of which Street and Burges were the prominent exponents. After his father's retirement in 1875, Belcher associated himself at various times with a succession of partners—J. W. James, Beresford Pite and J. J. Joass. His most important work was that resulting from his partnership with the last, and it evidences a monumental strength and dignity of design to which his earlier achievements had been leading. His intense and always vividly expressed admiration for Norman Shaw was a great factor in his artistic evolution, but even a more powerful one was due to the preparation and study involved in his production of the important volumes on *The Later Renais-*

*sance in England*, in which he was associated with Mervyn Macartney as joint author. His Electra House, Finsbury, and Whiteley's vast store, Bayswater, are admirable examples of business premises based upon plans thoughtfully and practically conceived, and possessing a fine and dignified architectural treatment. Belcher was not responsible for many churches, but his Holy Trinity church, Kingsway (1909), is an interesting essay in the classic manner, and the Catholic Apostolic church in Maida Vale being on very similar lines, may compare with any of the Gothic town churches designed by Pearson. His domestic work—especially that at Stowell Park for the Earl of Eldon—had much grace and charm, and evidenced his sympathy, previously noted, with Norman Shaw's methods. Apart from his profession Belcher displayed considerable gifts as singer, composer and conductor. His talents received recognition in many directions and he was the holder of various distinctions in his own country and elsewhere. He was elected Royal Academician in 1909, and in 1907 received the gold medal of the Royal Institute of British Architects, of which he had been president in the preceding year. Russia, Belgium, Germany, Spain and the United States elected him a member of their several architectural societies. He died in London Nov. 8 1913.

(C. H. To.)

**BELGIAN CONGO** (see CONGO FREE STATE, 6,917).—Readjustments of the Congo-Uganda frontier, and the incorporation in 1919 of the greater part of Urundi and Ruanda, increased the area of the colony by some 19,000 sq. m., and its inhabitants by, approximately, 2,500,000 to 3,000,000. The total area of Belgian Congo in 1920 was estimated at 928,000 sq. m. A census was taken for the first time in 1917. It was not complete but indicated that the pop. was little more than 7,000,000. In 1921, including Ruanda and Urundi the estimate was 10,000,000. In 1918 white inhabitants numbered 6,487, of whom 3,307 were Belgians. British numbered (in 1917) 820, of whom 588 lived in the Katanga province. Elisabethville (founded 1910), the capital of Katanga, had a white pop. in 1920 of about 1,600. It had many fine buildings and most of the amenities of a European town.

*Trade, Agriculture and Communications.*—The most striking development in the resources of the country, from 1909 was the exploitation of the copper mines of Katanga. They were worked by the Union Minière, in which British capital was largely interested. Since Dec. 1909 the mines had had a direct outlet by railway to the E. coast at Beira. The output of copper rose from 997 tons in 1911 to 27,462 tons in 1917; it was 22,000 tons in 1919 and 19,000 tons in 1920. The copper-bearing belt is about 250 m. long and from 25 to 50 and more m. wide. The chief mine is at Kambove and has been worked since 1913. The ore is smelted at Lubumbashi, where in 1918 were seven furnaces with a producing capacity of 40,000 tons a year. Up to the outbreak of the World War all the Katanga copper was bought by Germans; thereafter it was sent to Britain. Tin is also mined in Katanga, but up to 1921 little had been done to exploit its iron and gold deposits and diamondiferous areas. Since 1913, however, an extensive diamond field in the Kasai basin along the Angola border has been worked. The stones, averaging ten to a carat, are found in the river gravel or in alluvial deposits. The output was about 90,000 carats in 1917 and over 200,000 carats in 1920. The gold mines at Kilo and Moto, worked since 1905, had an output in 1918 of some 90,000 ozs. The gold is found in placer deposits.

Next in importance to copper mining was the development of the palm-oil industry, which up to 1911 had been practically confined to the Mayumba district. In that year the British firm of Lever Bros. obtained large concessions in the interior to develop the cultivation of the oil-palm and to erect factories on the spot for crushing the oil. The company set to work with energy and the result was seen in largely increased exports. In 1910 the export of palm kernels was 6,141 tons, of palm oil 2,160 tons; in 1916 the figures were 22,391 tons and 3,852 tons respectively. Cocoa, rice and cotton were also increasingly cultivated and the fall in the value of rubber led to a much larger collection of copal, the amount exported, 2,139 tons in 1911, being 8,719 in 1916.

The value of exports, about £6,500,000 in 1910, was over £11,000,000 in 1916. During that period rubber fell from being 77% to 15% in value of the exports of produce of the colony, though the quantity exported—3,000-4,000 tons—was about the same. From 1914 onward copper and palm kernels and oil were the chief exports. A considerable part of the trade, export and import, was in transit, chiefly with French Congo, which had no direct communication with the sea except through Belgian Congo. The value of imports

fell from £1,300,000 in 1910 to £2,380,000 in 1914. It varied much during the World War, being £2,100,000 in 1915, not quite £5,000,000 in 1916, £3,200,000 in 1917 and £3,500,000 in 1918. Before the war 60 to 70% of the imports came from Belgium, which also took the bulk of the exports. During the war external trade was almost wholly with Great Britain, after 1918 Belgium recovered part of the trade, though that with Britain continued much above pre-war figures and was worth £2,000,000 in 1919.

Considerable energy was shown in railway construction and by the end of 1918 there were combined railway and steamer routes from the mouth of the Congo to Dar es Salaam and Cape Town. A railway 168 m. in length from Kabalo, on the Luabala, along the Lukuga valley to Albertville on Lake Tanganyika was begun in 1911 and completed in 1915. The railway which connects at Sakania with the Rhodesian railways and runs through Katanga reached Elisabethville in Oct. 1910, Kambove, the mining centre, in 1913 and Bukama, at the head of navigation on the Luabala in May 1918. The length of the Katanga line is 450 m. and it is of the standard South African gauge. From Chilongo, on the Katanga railway, the building of a line westward to the Angola frontier—about 400 m.—was in progress in 1921. This line is to link up with the Benguela railway and put Katanga in direct communication with Lobito Bay, thus reducing the distance to Europe, compared with the Beira route, by over 3,000 miles.

Progress was made in improving river and lake navigation. Kinshasa, on Stanley Pool, possessing better accommodation supplanted its neighbour Leopoldville as chief river port in 1915. In 1911-3 a pipe-line was laid from Matadi, on the Congo estuary, to Stanley Pool to supply the river steamers with petroleum for fuel and reservoirs capable of holding 8,000 tons of oil were built. In 1921 a seaplane service was started along the Congo river from Stanley Pool to Stanley Falls.

**Revenue.**—Taxes on imports and exports, not exceeding the equivalent of 10% *ad valorem*, direct taxation of Europeans, and a poll tax on native adult males, a tax on ivory and the Government share in the exploitation of mines were the chief sources of revenue; the administrative services and interest on debt the largest items of expenditure. The abandonment of the trading monopolies of the old Congo Free State, and the taking over of its loans put a severe strain on the resources of the colony. Revenue increased from about £1,400,000 in 1909 to £2,320,000 in 1918. In each of those years expenditure was greater than receipts by sums varying from £400,000 to £1,500,000 and new loans had to be contracted. The public debt in 1919 was 349,000,000 francs. With the development of commerce, and especially of the Katanga mines—in which the colony has a two-thirds interest—the prospects of balancing the budget became good. A loan of 500,000,000 francs was raised in 1921 for public works.

**History.**—From the date of its annexation by Belgium (Nov. 15 1908) the country was placed under the control of a colonial minister responsible to the Belgian Parliament, which has modelled the administration much on the lines of a British Crown Colony. The abuses and misgovernments which were fostered by the Leopoldian régime were remedied as quickly as was possible. Most of the trade monopolies held by Leopold II. and his associates were abandoned and foreign traders encouraged. Care was taken that the natives enjoyed security of land tenure—though ownership remained with the State—and the right to dispose of their own labour freely. Moreover in 1910 the natives were granted a measure of local autonomy; their chiefs were—for the first time—officially recognized and were entrusted with large powers. These powers had a tendency, however, to make the chiefs, at least those of minor importance, simply agents of the State.

Another step in decentralization was taken in 1912 by the subdivision of the former unwieldy territorial division and by the grant of wider initiative to the commissioners of the divisions. But it was found that the Government was still too highly centralized and, in 1914, the various divisions were grouped into four provinces over each of which a vice-governor-general presided, aided by a consultative council on which non-official Europeans had seats. This left the governor-general, and the council of government free to deal with matters affecting the colony as a whole, including the preparation of the budget. The governor-general had, however, practically no authority in the province of Katanga, which, in 1910, except that it had no separate budget, became a separate colony. Its vice-governor-general exercised all the executive functions of the governor-general and corresponded directly with Brussels.

In general the new native policy was successful, though trouble arose from the difficulty, due to crippled finances, of

securing an administrative personnel of the best type. Many of the old agents of the Congo State had to be retained. One of these officials in the Tanganyika region was in April 1912 sentenced to ten years' imprisonment for summarily executing 11 native prisoners, including 4 women and a child. But that the natives as a whole were satisfied was shown by their attitude during the World War. A column of about 600 men cooperated with French forces in the operations in Cameroon and other units aided in the defence of northern Rhodesia. An army of over 10,000 men was raised for service in the East African campaign. At the outset of the war Belgium had endeavoured—unsuccessfully—to preserve neutrality in her Congo colony, and the first act of hostility was committed by the Germans (*See EAST AFRICAN CAMPAIGNS*). In the result the north-western part of German East Africa was conquered by the Belgian native troops (as described in the article on the campaign) and from Sept. 1916 to March 1921 a considerable area of that country was under Belgian administration. Of this area nearly all the province of Urundi and the greater part of Ruanda were permanently assigned to Belgium by an Anglo-Belgian agreement of Sept. 1919. This was a notable addition not so much to the area as to the resources and population of the Belgian Congo. Ruanda and Urundi are healthy, fertile, high-lying regions, thickly populated and great cattle-raising areas. The agreement made Kivu entirely a Belgian lake. By a previous Anglo-Belgian protocol (May 1910) the Congo-Uganda frontier had been modified so as to give Belgium the western shores of Albert Nyanza and in Feb. 1915 another agreement fixed the frontier between Albert Nyanza and the Congo-Nile watershed.

Baron Wahis, the first governor-general under Belgian administration, was succeeded in May 1912 by M. Fuchs. In 1916 M. Henry became governor-general. On his retirement the Belgian Cabinet departed from precedent by choosing, Jan. 1921, as the new governor-general a man without previous colonial experience—M. Maurice Lippens, governor of East Flanders. M. Louis Franck, the Belgian Colonial Minister, paid a visit to the Congo in 1920. His visit coincided with a period of unrest both among the white civil servants and among the natives, due to the high cost of living. For some time the majority of the white officials were on strike, while certain native tribes rose in revolt.

*See A Manual of Belgian Congo, a British Admiralty publication (1920); M. Halewyck, La Charie Coloniale (3 vols. 1910-9); A. J. Wauters, Histoire Politique du Congo Belge (1912); E. M. Jack, On the Congo Frontier (1914); H. Waltz, Das Konsumtionswesen im Belgischen Kongo (1917); F. Fallon, L'Agriculture au Congo Belge (1918).*

**BELGIUM** (*see* 3.668).—On Dec. 17 1909, King Leopold II. of Belgium died at the castle of Laeken. He left behind him a Belgium richer and fuller of vitality than that to whose throne he had succeeded. His kingdom's immense economic development, which he had consistently aided and encouraged, had shown him the necessity for such a country, small but over-populated, of ample foreign markets and colonies. Leopold I. had sought to foster the colonizing spirit in Belgium, but without success. Leopold II.'s eyes were opened by the great African discoveries of 1878 to the possibility of realizing an ambitious scheme for acquiring in his country's interests a vast territory in the centre of the Dark Continent. Amid general scepticism, and aided by a mere handful of men, mostly officers, he had built up the independent state of the Congo. From 1895 onward the Belgian Government had associated itself in his work by opening credits to him, although Parliament remained hostile to the King's bold and enterprising policy. Belgian finance, however, took an interest in affairs on the Congo; and little by little there developed a section of public opinion favourable to the taking over by Belgium of the immense African territory. After a violent agitation against the methods of colonial government in the Congo State, conducted in Germany, England, and America, and supported by certain Belgian politicians, the Congo was ceded to Belgium in 1908.

King Leopold realized that if his country was to remain economically powerful her army must be strengthened, and to effect this was his constant preoccupation; but the Catholic party—in power since 1884—always frustrated his efforts, and up to the time of his death Belgium still preserved her system of recruiting by drawing lots, conscripts who had been drawn having the right to get themselves replaced by substitutes at the cost of a fine of 1,600 francs. This system of substitution was abolished by the Chamber in 1909, and the King on his death-bed signed the law enforcing personal service.

Leopold II. had expressed a desire to be buried with the utmost simplicity, in the early morning, and without official ceremonies. The Government did not think fit to conform to these wishes, however, and arranged an imposing funeral. He was succeeded by his nephew and nearest male heir, Prince Albert, whose consort, Elizabeth, had been born a duchess of Bavaria.

**I. PRE-WAR SITUATION, 1910-4.**—By Belgian constitutional law the heir-presumptive to the throne does not become king until he has taken the oath. Leopold II.'s death consequently entailed a temporary regency which, in accordance with Belgian law, was exercised by a *Conseil de Régence* composed of members of the Government:—T. Schollaert, L. de Lantsheere, J. Davignon, J. Licbaert, Baron Descamps, A. Hubert, A. Delbeke, G. Hellepette, J. Hellebrut, J. Renkin. On Dec. 23, in presence of the Chambers and of delegations from the constituent bodies of the country, King Albert I. of Belgium took the oath of allegiance to the Belgian Constitution. The new King had already shown his intention to carry on his uncle's work, having, while still heir-presumptive, made a journey to the Congo for purposes of investigation. But alongside that keen interest in colonial, economic, and military problems in which he resembled Leopold II., he also from the first showed anxiety for his kingdom's intellectual development and social organization.

Belgium had indeed advanced considerably during the reign of Leopold II. She had not only achieved a high degree of prosperity, but had also undergone an intellectual renaissance, giving birth during the second half of the century to a school of writers, painters, and men of science worthy of comparison with those of the neighbouring countries. Furthermore, the development of trade, with its increase in the numbers of industrial workers—in 1910 they numbered 1,270,484—raised social problems with increasing urgency. Belgian trade had found immense markets, thanks in part to the cheapness of its products due to low wages. The growing strength of the trade unions enabled the workers to claim an improvement in their material conditions, and Belgium began to find herself confronted by the difficulty of entering on the path of social reform without compromising her economic stability. Political struggles of peculiar intensity were rendering the situation still more delicate. In Belgium social and economic claims are always mixed up with purely political questions. Social and professional organizations are at the same time political groups, and their action makes itself as much felt in political affairs as in the economic sphere. In 1907 the trade-union movement was divided as follows:—

Socialist unions	142,035 members
Catholic "	40,521 "
Liberal "	1,020 "
Neutral "	11,667 "
Number of women in unions	10,517

The socialist unions first tested their strength in the campaign opened by the Socialist party in 1912 for universal suffrage "pure and simple." This campaign coincided with the violent struggle on the education question which began just then between the parties of the Left—Liberals and Socialists—and the Catholic party. The Catholics, who commanded a majority in the Chamber, introduced a bill to put the voluntary schools and the State schools on an absolutely equal footing. Education in Belgium, especially primary education, is largely in the hands of the religious denominations. Their schools, recognized and subsidized by the State, were in many communes the only teaching institutions. It was to these denominational schools that the Government proposed to accord the same treatment as that given by the State to its own official schools.

The proposal raised a storm of adverse opinion throughout the country. A monster demonstration organized by the Socialist and Liberal parties took place at Brussels. The Liberal party, rallying to the principle of universal suffrage at 25 years of age and the single vote, formed a *bloc* with the Labour party in order to oppose the Right, and they issued joint lists of candidates in most of the towns. The Catholic party, nevertheless, proved successful in the elections of 1912, preserving a majority in the Chamber.

These elections, maintaining in power a party that had governed uninterruptedly for 28 years, had grave consequences. The Catholic party was strongest in the rural districts and in the small Flemish towns. The Walloon districts, more industrial in character, returned a large majority of Liberals and Socialists. On the morrow of the Catholic victory violence of party feeling, much exasperated by the new Education Act, led to an outburst of rage and indignation in the more politically advanced parts of the country. In certain Walloon circles there arose the idea of the administrative separation of Flanders from Wallonia. Flanders should remain Catholic; the Walloon country should be free to have the advanced (Left) Government it desired.

This movement, combining with that concerned with the language question, threatened serious results. "*Flamingantisme*," which originated in democratic aspirations, seeking to bring together in Flanders the common people, Flemish of speech, and the French-speaking *bourgeoisie*, had little by little—obsessed by its dominant idea and by a sort of regionalistic mysticism—turned towards reaction. The language question had been dealt with by various laws—that of 1878 regarding the use of the languages by public authorities; that of 1898 about the publication of laws; that of 1910 on free secondary education; and by the laws of 1913, on the use of the languages in the army, and of 1914, on primary education, which were designed to complete the legal equality of the Flemish language with the French. Yet in the hearts of a minority, a desire was shaping itself to expel the French language from Flanders.

In 1913 a bill was introduced in the Chamber proposing the division of the army into Walloon and Flemish units, but was defeated by an immense majority. This did not deter three deputies—a Catholic, a Liberal, and a Socialist—from proposing to the Chamber in 1914 the *Flamandisation* of the university of Ghent, in which French was the official language.

The Government did not perceive that by pursuing a course of purely party politics they were stimulating the growth of this separatist movement, and despite the protests of the Left they once more brought before the Chamber their Education bill, which they had temporarily abandoned. To counter this, and to force upon the Chamber the adoption of the universal suffrage "pure and simple" which they demanded, in April 1913 the Socialist party organized a general strike, which spread over the whole country, involving many hundred thousands of workers. The Government would not yield, however, and their Education Act became law. If in this the Catholic party had gained an undeniable victory, it had been at the price of adopting compulsory education, which for many years past had been advocated by the Liberals. It was now enforced by the laws of May 29 and June 15 1914.

**Educational System.**—School attendance is obligatory from 6 to 14 years of age. The *Juge de paix* has to admonish recalcitrant parents; and if they persist in neglect of their duty, they are first officially warned before the final steps are taken of the infliction of a fine and the posting of their names in their commune. By the law of May 19 1914 each commune must possess an official school. One or more voluntary schools, if such exist in the district, may be "adopted"; but if this is done a communal school must still be provided, supposing it is demanded by a sufficient number of the inhabitants to ensure it an effective minimum attendance of 20 children. In all schools, whether official or adopted, the teachers must be Belgian and *diplômés*. The State inspects both communal and adopted schools, and they receive grants from the central authorities of province and commune. Education is free, and the necessary books and appliances are provided free for poor families. The syllabus of primary schools includes religion (but fathers can claim their children's exemption from religious instruction), moral teaching, reading, writing, arithmetic, weights and measures, the language used by the majority of the local population, geography, history of Belgium,

showing, hygiene, singing and gymnastics. In the girls' schools needlework, domestic economy, and housewifery are added. In agricultural districts agriculture, and horticulture are also taught. Further, the State subsidizes such initiative on the part of communes as the formation of classes (such as exist in Ghent, Brussels, and Liège) for backward and non-normal children, on the provision of 4th-degree instruction. This 4th degree, first adopted by the commune of St. Gilles, consists of technical instruction for children of 12 to 14. Its object is to give elementary training sufficient to enable the child to specialize as artisan or craftsman, and so to enter industrial life already qualified.

Belgium's efforts to develop the technical training of her population increased steadily during the last few years before the war, much being done in this way by the provinces and communes. Hainault (Hainaut) organized an admirable centre of technical instruction at Charleroi under the name of the *Université de Travail*. Future workers, male and female, are admitted to its courses at the age of 13 and they receive salaries, which enable them to pass through the necessary years of training. In 1912 1,700 pupils attended this school. All trades are taught there, each with the best possible equipment of tools and machinery. Reading-rooms are open to the pupils, and even also to workmen not attending the school who think they can in the slightest degree improve tools or machines. Concurrently with the technical courses, general courses are given, notably in foreign languages, so that pupils may be in a position to follow the technical periodicals of great neighbouring countries. The province of Hainault finds the large funds necessary for supporting this immense institution by means of a special tax on industrial profits. The great manufacturers of the province not only accepted this tax without complaint, but every year make many voluntary donations to the *Université de Travail*. To encourage the use of this school by the working-classes the employers of Hainault decided to accept no workers under the age of 18; while leaving well-paid posts to every pupil passing out of the *Université de Travail*. This close collaboration of public authorities, manufacturers, and workers produced most remarkable results in the course of a few years. Besides the *Université de Travail* there are provincial schools of arts and crafts, agricultural mechanics, hosiery-weaving, and industrial chemistry. The communes and many trade unions provide housewifery schools for young girls and schools for adults.

As regards agriculture, the State endeavoured to promote specialization in the subject by courses of lectures given all over the country. Such efforts made by public authorities, more especially by the provincial and communal administrative bodies, whose powers are very extensive, are rendered necessary by the social conditions of the country.

**Population.**—A population which in 1900 numbered 6,693,548 had in 1910 become 7,423,782—an increase of 10.91%, or over 1% per annum. Density increased from 227 to 252 inhabitants per sq. kilometre. East Flanders contained 374 inhabitants per sq. km., the province of Antwerp, 342, Hainault, 331, the province of Liège, 306, West Flanders, 276, Limburg, 114, the province of Namur, 99, Luxembourg, 52. Thickly populated areas and urban centres developed with lightning rapidity: in Antwerp the population increased 167% in 50 years, in Charleroi 147%, in Liège 105%. The whole population depended for support on the internal resources of the country emigration being almost negligible: in 1910 only 38,854 persons left the country (5% of them born in Belgium), principally for France (52%), Germany (13%) and Holland (12%). On the other hand, 44,950 immigrants settled in Belgium, coming chiefly from France (41%), Germany (21%) and Holland (16%).

To maintain such a dense population agriculture had to be brought to a pitch of intensiveness unknown elsewhere; and industry, with such vast numbers of hands to draw on, was able to develop with marvellous rapidity.

**Industries.**—The various industries of Belgium employ a large part of the population. In 1910 this industrial population comprised:

Employers, or persons employing members of their own families as employees or workers	Persons	Per cent.
Members of families as above	260,521	15.23
Employees	91,693	5.36
Workers	87,463	5.12
	1,270,484	74.29
<b>Total</b>	<b>1,710,161</b>	<b>persons</b>

These were divided among the different branches of industry as follows:—

	Per cent.
Textile industry	15.36
Metallurgical industry	13.32
Clothing	11.94
Building	9.58
Mining	9.08
Timber and furniture-making	8.30

In 1914 glass-making employed 12,000 workmen, maintained 29 furnaces and produced annually 400,000,000 francs worth of glass, or one-fifth of the world's entire output, 95% being exported. The unchallenged superiority of the Belgian glass-workers, with their

centuries of specialization behind them, ensured a privileged position in the markets of the world. Even so, technical development was still advancing, and in 1914 the new Fourcault process had just been successfully introduced. By means of it glass is drawn without being touched by hand from the moment it comes out of the furnace until it is ready for sale as finished merchandise. There were, besides, seven factories producing annually 2,500,000 sq. metres of plate glass, representing a value of 28,500,000 francs, nine-tenths being exported; and the factory of Jumet produced annually 12,000,000 bottles. The Belgian cut-glass trade was equally important. The Val St. Lambert, with 5,300 hands, produced daily 250,000 pieces, an output (90% exported) realizing annually 13,000,000 francs.

In 1913 the metallurgical trade included: 21 high furnaces with 20,080 hands producing 96,000 tons of cast iron; 6 steel-works with 7,700 hands producing 1,134,000 tons of rough steel and 671,000 tons of finished products; 15 iron-works with 3,402 hands producing 27,100 tons of finished iron and 19,300 tons of finished steel. The steel industry, including coke-fired furnaces, employed in 1913 a total of 39,500 hands, and was represented by 41 factories with 2,498 coke-fired furnaces, employing 4,229 hands and producing 3,523,000 tons; 19 works with high furnaces, 5,289 hands, producing 2,484,690 tons; 28 Siemens-Martin furnaces producing 274,450 tons of rough steel; 84 converters producing 2,192,180 tons of rough steel and 1,409,940 tons of finished steel; 38 transforming plants producing 394,350 tons of finished iron and 448,400 tons of finished steel. The zinc industry possessed 14 foundries with 600 furnaces and 10 rolling mills, and produced annually 200,000 tons of rough zinc and 51,000 tons of sheet zinc. It employed 9,300 hands. The output, nine-tenths of which was exported, was worth 115,000,000 francs.

The collieries, the presence of which brought also the iron, zinc and steel industries to the provinces of Liège and Hainault—the coal-yielding provinces—occupied a particularly important place in Belgium: 125 collieries, possessing 305 pits and employing 145,337 men, were producing annually 22,841,590 tons. In quantity this output nearly sufficed for the needs of the country, which consumed 26,000,000 tons per annum. But in quality the deficit was considerable. The output of steam and domestic coal was excessive, permitting an export of 6,000,000 tons, 5,000,000 of which went to France; while the lack of gas and coking coal necessitated the importation of 9,000,000 tons from Germany.

Although since 1910 the import of coal had exceeded the export, the discovery of two new coal fields permitted the hope that in the future Belgium would produce a quantity far in excess of what she needed for internal consumption. In 1901 deposits of coal were found in the Campine at depths of 430 and 630 metres. The first concessions were granted in 1906, the first sinkings—exceptionally difficult because of the water-bearing strata encountered—began in 1909. No pits had started work before the war. Experimental borings, commenced in the south of Hainault in 1908, established the existence of fresh deposits at depths of 400 and 800 metres. No concession had, up to 1921, been granted by the State in these coal fields.

There were 62 factories for making coal dust into briquettes and other forms of patent fuel. In 1913 these employed 2,000 hands and produced 2,608,640 tons.

Next to the mines must be mentioned the important industry of the stone quarries. In 1913 1,556 quarries, 481 of them subterranean, employed 34,893 workmen, and produced 70,500,000 francs worth of paving-stones, broken stone, hewn stone, marble, chalk, lime, phosphates, plastic clay, dolomite and slate. Depending on the quarries were 79 cement factories in a state of rapid development; the cement export having risen from a value of 12,000,000 francs in 1908 to that of 22,000,000 francs in 1912.

A third group of important industries consisted of the textile manufactures of Flanders (flax, cotton, hemp, jute), and of the Verviers district (wool). In 1910 they accounted for 270,000 workers, employees, and masters; while the related clothing industry employed another 200,000 persons. The total value of the products represented 800,000,000 francs, 350,000,000 of which came from export.

The following table will indicate the relative importance of the different textile industries, and their development during the last years before the war:—

	Persons Employed.	
	1896	1910
Linen	26,205	42,479
Hemp and Jute	3,610	6,509
Wool	32,285	32,846
Cotton	20,435	48,157
Silk	655	1,391
Artificial silk	0	3,573
Lace	47,571	81,213

Imports of raw materials, spun raw materials and woven goods amounted in 1911 to 838,700,000 francs, in 1912 to 985,300,000 francs, in 1913 to 998,400,000 francs. The exports of raw materials, spun goods, and woven goods amounted in 1911 to 871,400,000 francs, in 1912 to 1,033,400,000 francs, in 1913 to 998,700,000 francs.



**Commerce.**—Belgian commerce was as flourishing as Belgian industry. Facilitated by a network of ways and communications comprising 2,000 km. of water-ways (67 m. per sq. km.), 4,665 km. of broad-gauge railways (158 m. per sq. km.), 4,107 km. of narrow-gauge railways, 9,851 km. of main roads, and 32,000 km. of local roads, import and export trade and transport were intensely active. Belgium's free-trade policy largely contributed to her commercial prosperity. In 1913 the import duties affected only 16.8% of imported goods. They were, moreover, extremely light, in 1900 representing 2.3% of the value of imports, in 1910 1.6%, in 1913 only 1.4%. It is true that a movement was already beginning towards the imposition of duties to check the dumping practised by certain foreign industries, or to induce other nations to admit Belgian goods freely; but this was merely a defensive policy, rendered necessary by that of foreign states.

Commercially Belgium held the sixth place in the world. The total figures of her import and export trades, not including goods in transit, rose as high as 8,765,673,061 francs. In 1913 this total was composed as follows:—

	Tons.	Francs.
Imports . . . . .	32,656,282	5,049,859,234
Exports . . . . .	20,885,182	3,715,813,827
In Transit . . . . .	7,803,734	2,459,924,818

Between 1900 and 1913 Belgian trade had doubled, marking the greatest rate of progress it had ever achieved.

The following table analyzes the elements of the import and export trades:—

	Imports thousands of francs.	Per cent.	Exports thousands of francs.	Per cent.
Live animals . . . . .	65,273	1.3	4,444	1.2
Beverages and foodstuffs . . . . .	1,034,822	20.5	327,663	8.8
Raw materials and goods having passed through only one simple process of preparation . . . . .	2,667,035	52.8	1,826,078	49.1
Manufactured articles . . . . .	869,478	17.2	1,436,430	38.7
Gold and Silver . . . . .	413,251	8.2	81,230	2.2

The bulk of the imports consisted of foodstuff products and raw materials. Exports were chiefly manufactured articles and materials which had been subjected to a single process.

In 1913 the trade was chiefly with the following countries:—

	Imports in thousands of francs.	Exports in thousands of francs.
France . . . . .	1,000,297	762,187
Germany . . . . .	*761,765	940,378
Great Britain . . . . .	518,473	317,710
Holland . . . . .	356,998	320,930
United States . . . . .	420,496	103,381
Argentina . . . . .	316,797	91,154
Russia . . . . .	267,237	88,379
Congo . . . . .	48,674	26,978

It is interesting to note that 87.4% of goods in transit travelled by land and 57.4% by sea—figures which demonstrate the immense importance to the port of Antwerp of the foreign hinterland.

Marine trade was served by the ports of Antwerp, Ghent, Ostend, Zeebrugge and Nieuport. The total tonnage of Belgian ports amounted in 1910 to 15,101,171 tons, in 1911 to 16,353,931 tons, and in 1913 to 16,907,417 tons, Antwerp taking first place. The details are as follows:—

	1900	1910	1912	1913
Number of vessels . . . . .	5,250	6,796	7,043	7,134
Tonnage . . . . .	6,696,370	12,654,318	13,756,880	14,139,615

In 1913, out of 61,500,000 tons of total imports and exports, 23,650,000 tons passed through Antwerp. The public authorities had devoted ceaseless attention to the development of the port of Antwerp, and at the outbreak of the war it was one of the finest ports in the world, possessing 5,500 metres of riverside wharves, 19,000 metres of wharf-docks, 392 cranes of 2 tons, 8 cranes of 15 tons to 120 tons, 12 pneumatic floating grain-elevators, one automatic coal-weigher, one barge for ore. The Entrepôt Royal could accommodate 100,000 tons of goods; the granary store had a capacity of 350,000 tons. Numerous private stores and warehouses, a close network of railway lines, and six great dry-docks completed the equipment of the port.

**Agriculture.**—Belgian agriculture was no less important than Belgian trade and industry. In 1914 the value of its products amounted to two milliards of francs. Agriculture was carried on at a high degree of intensity. Of the 2,945,000 hectares which constitute the national territory, 1,950,000 were in cultivation and pasture, among a population of nearly 7,800,000. The cultivable area per head of population was only 25 ares (in France 100 ares, in Great Britain 45 ares). Belgium, therefore, could not be self-support-

ing. She was importing 2 of her consumption of corn. Other feedstuffs were produced in almost sufficient quantity, thanks to scientific specialization. In 1914 stock-breeding produced 300,000 tons of meat, 40 kgm. per head of population per annum. Of sugar, potatoes, fruit, vegetables and horses there was even a considerable surplus available for exportation. The subdivision of land had been carried to an extreme point, 1,950,000 hectares being divided among 829,000 cultivators; 458,000 holdings were of less than one-half hectare; the average for the rest being about five hectares per farm. Thanks to intensive breeding (Belgium in 1914 possessed 317,000 horses, 1,879,000 horned stock, and 1,954,000 pigs) agriculture commanded larger supplies of manure than in any other country (275 kgm. per hectare). It followed that the yield per hectare of wheat, rye, barley, oats and potatoes also exceeded that of any other country. The area of cereal cultivation was not very extensive; 750,000 hectares out of a total of 1,430,000 hectares of ploughed land. Permanent pasture represented only 26% of cultivable land (65% in England); while on the other hand plants used for industrial purposes, root-crops and forage-crops which yield a much higher return in money, were largely cultivated.

Thus industrial crops occupied 95,000 hectares; forage, 292,000 hectares; orchards, 65,000 hectares; market gardens, 27,000 hectares; horticulture, practised especially in the environs of Brussels and Ghent, occupied 100,000 hectares, and provided a considerable export. As regards breeding, the export of Flemish horses brought in 50,000,000 francs.

**Finance.**—Despite the country's growing prosperity the revenue from taxes was not increasing in amount. Revenue and expenditure for the period 1910-4 (in thousands of francs) were as follows:—

	Revenue.	Expenditure.
1910 . . . . .	815,404	829,456
1912 . . . . .	777,501	895,773
1914 . . . . .	807,314	806,754

Taxes produced an average of about 300,000,000 (40 francs per head of population) of the revenue. In 1913 the national debt amounted to 4,277,000,000 francs. The analysis is as follows (in thousands of francs):—

	Funded Debt.	Floating Debt.	Total.
1910 . . . . .	3,793,403	136,204	3,839,608
1912 . . . . .	3,739,133	352,485	4,092,119
1913 . . . . .	3,743,027	534,272	4,277,299

**The Army.**—Fully occupied with her economic development, and confiding absolutely in the neutrality which was supposed to be her safeguard, Belgium was giving no real thought in these years to defence. The Liberal party alone stood for the principle of universal military service. The Catholic party had always from electoral motives been firmly opposed to any reinforcement of the army or increase in military expenditure. The King, however, well informed on the international situation, never ceased to press for improvement in the country's military condition. In 1912 M. de Broqueville, then head of the Government, succeeded, despite his party's reluctance, in passing an Act establishing the principle of universal military service. In 1913 a complete reorganization of the army was voted. Having obtained the necessary credits for the fortification of Antwerp, Baron de Broqueville got several bills passed and promulgated numerous orders bestowing extended powers on the general military staff; creating a Supreme Council of National Defence (Conseil Supérieur de la Défense Nationale); establishing schools of artillery, cavalry and military engineering; reorganizing the Ecole de Guerre and the Ecole Militaire; creating inspections générales of infantry, cavalry and commissariat; and considerably improving the equipment. These reforms were to be completed as a whole in five years. Already, however, the effective forces were augmented in number; the inclusion of all social classes in the army made it truly representative of the nation; a completely organized mobilization was prepared; confidence was at last felt in both officers and troops.

Such was the situation when suddenly the army found itself called on to the stage of war, to confront alone the formidable hosts of Germany.

**II. THE WORLD WAR, 1914.**—On Aug. 2 1914, the German Minister at Brussels handed the Minister for Foreign Affairs an ultimatum requiring him to permit the German troops to pass through Belgian territory, and to use the citadels of Liège and Namur for the purposes of their operations against France. A delay of 12 hours was granted for the acceptance of Germany's proposals; on the expiration of that time Belgium would be treated as an enemy. That same night the King presided at the council of ministers; the reply was formal. Belgium was resolved to defend her neutrality; sword in hand. On July 20 the Belgian army had been placed on a reinforced peace footing. On July 31 mobilization had been ordered; 15 classes of militia had been called up, the eight first forming the offensive force, the others

being reserved for the defence of the fortresses. Loyal to her international obligations, Belgium had disposed her forces so as to defend all her frontiers. The first division kept watch in England's direction; the third confronted Germany; at Namur the fourth defended the entrance of the Meuse Valley; while the fifth, concentrated in Hainault, guarded the French frontier.

Germany's ultimatum showed on which side danger lay. Yet the Belgian Government, wishing to sustain to the last moment the part assigned to it by the treaty of 1839, still refused the support of France. It was only when Germany's intention to cross her territory became evident that Belgium informed the nations who had guaranteed her neutrality that she assumed the defence of her fortresses, and that she declared herself ready to coöperate with the Powers in maintaining the integrity of her territory. The third division of the army, under General Leman, was charged with the defence of Liège; the fourth division held Namur; the bulk of the army was massed in the centre of the country, covering Brussels and the lines of communication with France, so as to be prepared for all eventualities.

The Government had convoked the Chambers for Aug. 4 on grounds of urgency, and the King had announced his intention of making the speech from the throne. On the morning of Aug. 4 the King, accompanied by the Queen, proceeded to the Parliament House, in the midst of great popular enthusiasm. His speech affirmed the country's definite decision to offer the enemy an unyielding resistance. The Chamber greeted these words with wild enthusiasm. After the departure of the King, who proceeded immediately to G.H.Q., Baron de Broqueville, as head of the Government, read the note just sent by Germany to the Minister for Foreign Affairs, expressing her intention "to execute, if necessary by force of arms, the measures of security rendered indispensable in view of French menaces." Parliament unanimously accepted war with all its consequences. M. Van der Velde, leader of the Socialist party, announced that his group would support the Government unreservedly. All parties rallied round the King. The Government, moreover, ceased to be a party-government, MM. Goblet d'Alviella and Hymans, leaders of the Liberal Left, and M. E. Van der Velde being appointed Ministers of State.

The Chamber at once set to work on the measures of law necessitated by the situation. Suddenly M. de Broqueville rose to read a telegram announcing the violation of Belgian territory by the German army. The deputies from Liège and its neighbourhood informed their colleagues of the news that their districts had been brutally invaded and occupied; and at once departed for their constituencies, to afford help and protection to the suffering inhabitants. As hour by hour the invasion of Belgium proceeded, the Chamber continued to pass laws delegating its powers, in the event of the invasion of each locality, to the local authorities; augmenting the contingent of the army; granting the Government a preliminary credit of 200,000,000 frs.; penalizing crimes and offences calculated to endanger the safety of the State; cancelling the ineligibility of soldiers for membership of Parliament, in order to permit the immediate enlistment of several members.

The spirit of the country was the same as that of the Chamber. Volunteers were besieging the recruiting-offices. In two or three days 40,000 had been equipped, and tens of thousands, still in their civilian clothes, had been dispatched to the camps for volunteers that were being formed in all directions.

A series of regulations were issued by the Government intended to prevent food-hoarding and the raising of prices, and to assure the food supplies of the nation. Bread was rationed at 400 grammes per head per day; in Sept. this ration was reduced to 250 grammes. Maximum prices were fixed for bread and the various kinds of flour. The right of requisition was given to governors of provinces for bread and flour; to burgomasters for potatoes, salt, sugar and rice; in the event of the invasion of a province the governor's powers of requisition passed to the *commissaires d'arrondissement*, in the case of their retreat to the burgomasters of the communes.

At the *Ministère de l'Intérieur* a Central Commission was formed, consisting of one delegate for each province, with representatives of the central administration and of the army, its duty being to see to the sharing-out of the food supplies among all parts of the country. In each province the *députation permanente* (standing committee) of the provincial council was made responsible for the victualling of the province, and had to form committees in the communes to distribute provisions. Each week a return of all the food in the province had to be made by the *députation permanente*.

To ensure the proper working of this great system of food control and distribution, newly created in every detail, penalties were decreed for anyone trying to withhold goods from requisition; such hoards were to be confiscated and handed over to the *Bureaux de Bienfaisance*.

While these regulations were framed to safeguard the nation's economic life, its administrative life was being safeguarded in the event of enemy occupation by the measure passed by the Chamber on Aug. 4 providing for the delegation of powers, which was supplemented later by various royal decrees. Notices were posted in every commune of the country, warning the public that civilians were definitely forbidden to take part in operations of war, and that all arms must at once be given over into the hands of the authorities.

*The Invasion.*—During the night of Aug. 3-4 the German army crossed the Belgian frontiers. It immediately put into practice a system of terrorism in its dealings with the inhabitants, hoping in this way to terrorize the Government, demoralize the army, and break the national resistance.

The forward march of the German army was marked by an uninterrupted succession of atrocities. Once it was perceived that the Belgian army meant to offer a resistance on which Germany had not counted, pillage, burnings, and massacres began.

On the pretext that the inhabitants were armed, that *francs tireurs* attacked the German troops, the invading military command methodically organized the devastation of the country. Maps were issued to the officers indicating what towns and villages were to be burned down. The siege of Liège, with the preliminary repulses suffered by the German regiment which first attacked the outer forts, gave the signal for a campaign of reprisals directed against the civil population. The villages of Berneau, Moulant, Blegny-Trambleur, Barchon, Melen, Soumagne, Romsée, Harcourt, Hermée, Heure le Romain, Vivegnies, Julemont, Olme St. Hadelin, Battice, Grivegnée, Sprimont, Erneux, Francorchamps, and the towns of Visé and Herve, were burned to the ground, although they had been occupied for several days by the German army. Scenes of indescribable savagery were enacted: 623 persons were shot, massacred, or driven with blows of the rifle-butt into the flaming houses to be burnt alive. At Melen 72 men chosen haphazard were shot *en masse*, and finished off by blows with the butt-end under the eyes of their wives and children, who were then ordered to bury them at once. At Soumagne 55 men were shot by the firing-party detailed for executions, while the soldiers perpetrated shocking massacres of men, women and children in the village. At Visé, after the massacre of more than 20 persons, 631 men were led away captive. Not a single village escaped the fury of the troops; everywhere there was a reign of fire and sword. The burnings were scientifically organized. All units were provided with incendiary pastilles, and petrol was sprayed on the houses to be destroyed. At Herve, where more than 300 houses were burned, German inscriptions written by the troops revealed that the abominable deed had been performed by the "Incendiary Army of Düsseldorf."

The entry of the German troops into Liège was marked by tragic incidents. Although the town was completely in the invader's hands, on Aug. 7 German companies suddenly opened fire in the most frequented quarters, where they also set fire to 38 houses, shooting down the inhabitants as they tried to escape. Fifty-two persons perished in the flames or fell by the German bullets.

Between Aug. 4 and 20, in the province of Liège alone, 1,061 persons were massacred, shot, hanged, or burnt by the German troops; more than 2,000 houses and 4 churches were burnt deliberately and by order, not counting those destroyed by bombardment. In the province of Limburg during the same period 65 persons fell victims to similar cruelties.

Liège having been occupied, the German army advanced up the Meuse Valley, and at the same time invaded the province of Luxemburg. The first French contingents now joined the Belgian troops in the neighbourhood of Dinant, Namur, and Arlon. Everywhere advance-guard fighting was delaying the enemy's progress and every skirmish was followed by cruel reprisals on the civil population.

The siege of Namur began on Aug. 20, and was the signal for more butchery. On the eve of the attack on Namur scenes of incredible savagery were enacted in the towns of Andenne, Seilles, and Landen. Without having received the faintest provocation, for three whole days the German troops in occupation of these places never ceased massacring and burning. More than 250 persons perished. These scenes of horror, accompanied by the burning of over 150 houses, culminated on Aug. 21 in the execution of numbers of men, by order of the military authorities. They were shot *en masse*, and finished off with the bayonet or the butt-end, or by kicks. The whole canton of Andenne suffered similar horrors; nine persons were murdered by the German soldiers after subjection to horrible tortures.

Other localities suffered as cruelly. At Spontin 130 of the 160 houses that composed the village were burnt and 43 persons were massacred. At Somme-Leuze, Franc-Waret, Leuze-Longchamps, fire and murder reigned. Scarcely had the tragedy of Andenne been finished when the small town of Zamines was the scene of a yet more terrible drama. After skirmishes with Belgian and French advance-posts, the Germans, who had fought pushing a screen of civilians in front of them, made the civil population responsible for their losses. All the men were first shut up in the church, and then massed in a field, and on the word being given by the military commanders they were shot down by machine-guns. Some were finished off afterwards, chiefly by stretcher-bearers of the Red Cross; 383 men perished, about 100 were wounded, only 200 escaped. The town was burnt to the ground. The whole canton was subjected to horrible atrocities; in the neighbouring villages 114 men were killed by German troops and 567 houses burnt.

Just at the time of the fall of Namur, the German military at Dinant organized an appalling demonstration of terrorism. The town had been occupied on Aug. 22 after some hard fighting with French troops. At nightfall on Aug. 23 German soldiers rushed shouting about the streets, and everywhere fires broke out. The church, the town hall, the entire town were soon in flames. The inhabitants, arrested *en masse*, were either massacred, or else driven into different enclosed places where, after a while, a methodical extermination was commenced. In the presence of their families men were formed into groups and shot; 665 persons were killed, including 75 women and 35 children. This horrible butchery was copied in the neighbouring villages. All of them were partially or completely burnt, any men found—the inhabitants had taken to the woods—were shot; at Anthere and Surice more than 40 men were executed. In the cantons of Dinant, Walcourt, Florennes and Gedinne 946 persons were put to death; and besides the whole town of Dinant and two entire villages—Outraye and Sorinne—1,732 houses and seven churches were destroyed.

On Aug. 23 the German troops entered Namur. Warned of the massacres by frightened peasants who had come fleeing before the enemy, the inhabitants abstained from any demonstration of feeling. The entry of the victorious army was devoid of incident. Yet suddenly on Aug. 24 a violent fusillade rang out in the streets, to continue all that day and all the next. The bishop, Mgr. Heylen, proceeded to the German headquarters to protest against this useless cruelty. He was arrested. After two days the terror ceased; 75 persons had fallen, 15 of them women and 4 children. The town hall, the communal archives,

and 110 houses had been burnt down. In the villages surrounding Namur, also, the same brutal work had gone on; between Aug. 23 and 26, 53 men were butchered and over 200 houses burnt.

While thus in the province of Namur 1,949 inhabitants were murdered, and more than 3,000 houses systematically burnt (not counting those destroyed by ordinary acts of war), the province of Luxemburg in its turn was suffering martyrdom. From Aug. 11 onward, wherever the enemy appeared in Luxemburg, atrocities followed, those at Rossignol, Arlon, Zutigny, Ethe, and Latour being sadly notorious. All these massacres were reprisals for engagements with the French forces. After the battles of Aug. 22 wounded soldiers found in the cantons of Virton and Etalle were killed, and the civil population hunted down and decimated. At Bleid 84 French wounded were tortured and then shot. At Latour Prince Oscar of Prussia presided in person over the execution of 71 inhabitants. At Ethe 218 persons were killed. The inhabitants of Houdeumont, warned of the fate which awaited them, escaped massacre by flight; 11 of them were found by the Germans and put to death. At Touches the burgo-master was hanged; at Zutigny 84 men were executed; at Rossignol, after the village had been set on fire, all the men were collected together and driven as far as Arlon, where 165 of the poor wretches were shot in cold blood. During the month of Aug. over 800 inhabitants of this province perished, and over 1,500 houses were deliberately destroyed.

While the German army was dominating the Meuse Valley by the seizure of Namur, it was at the same time working towards the heart of the country to assure a route for the invasion of France. The Belgian army, after its victorious stand at Harlen on Aug. 12, isolated, unsupported, menaced by 11 enemy army corps, was now forced to fall back on Antwerp.

On Aug. 19 the German army entered Louvain. Just as Visé had been burnt to terrorize the Liégeois, and Andenne and Dinant to bring about Namur's submission, so Louvain had to be burnt in order to hold a terrible example up to Brussels. When the German army was in effective occupation of Louvain, menaced with no further trouble, orders were suddenly given to burn the centre of the town. The inhabitants were subjected to cruel mental torture. The men were collected and decimated, 79 being shot in the presence of their wives and children, while 334 others were sent captive to Germany, where they were paraded through the streets of Cologne under the insults and threats of the populace who pelted them with mud and stones.

Louvain's cathedral of St. Pierre was devoured by the flames, her ancient university and marvellous library were annihilated, and 1,120 houses were ruined. The suburbs suffered likewise. In that canton 1,717 houses were burnt down, 861 houses pillaged, 226 inhabitants shot, and 653 deported to Germany. Aerschot was reduced to ashes, and 178 of its inhabitants were killed.

Enraged by the opposition they met within the environs of Tirlemont, and by the sorties of the Antwerp garrison, the Germans vented their fury upon the numerous villages of Brabant, 594 inhabitants of which perished in the course of burnings, pillagings, and executions.

On Aug. 20 the German army entered Brussels. The entire Belgian army was massed under the protection of the forts of Antwerp. Sorties were made on Aug. 25 and 26 and Sept. 4; on Sept. 9 a general sortie of all the Belgian forces took place, with the object of diverting pressure from the French army, which was fighting on the Marne. Forced to protect itself from the Belgian army's perpetual attacks on its rear, on Sept. 28 the German army commenced the siege of Antwerp. On Oct. 6, after the destruction of the forts, the Belgian army retreated; and on Oct. 10, having eluded capture by the enemy it took up position on the Yser.

The siege of Antwerp brought yet more fire and carnage. Over 160 persons in the fortified zone fell victims to the German soldiers. The town of Termonde, where the Belgian army again and again successfully opposed the crossing of the Scheidt by the German troops, was at last taken, and was then burnt to the ground.

The province of Hainault did not escape. At Charleroi, after the great battle which took place there, 108 persons were massacred, at Marchienne au Pont 75, at Mons 30, at Tournai 34, at Châtelet 67. In the other villages through which the enemy forces passed, 182 persons were put to death.

It remains to mention the massacres perpetrated by the invaders in East and West Flanders. For these provinces, however, precise figures cannot be quoted, the work of compiling the lists of victims not being yet completely terminated.

*The Occupation.*—Brussels once in her power, Germany began to organize the occupation of the country. The activities of the government of occupation—headed successively by von der Goltz, von Bissing, and von Falkenhäusen—were considerable in all spheres. Always the same main policy emerged: in matters political, economic or social, the one aim of Germany was to make Belgium and all her resources serve the needs of the war; while preparing for her annexation—at the very least for her absorption—in the event of the German victory, and rendering her in any case innocuous as an independent nation by effecting her economic ruin.

The governor-general formed round him a central government, in which the *Zivilverwaltung* (civil administration) played the chief part. Executive powers were in the hands of the governor-general, who legislated by promulgation of orders. A German governor was placed over each province. The Belgian commissaries were deprived of their authority over the *arrondissements*, being replaced by Germans, subordinate to whom were the military commandants who controlled the cantons. The country was divided into the *Gouvernement Général*, placed directly under the authority of the *Zivilverwaltung*; and the *Zones d'étapes*, including Flanders, the *arrondissements* of Tournai and Mons, and the southern part of the province of Luxembourg, governed by the military authorities, who had the right of promulgating orders. These *Zones d'étapes* were completely separated from the rest of the country. Access to them and exit from them were forbidden without permits, which were not readily granted.

Everywhere *bureaux de contrôle* were established to keep a watch on the inhabitants, persons placed under their special surveillance being obliged to report themselves periodically. A network of espionage was spread over the country, enabling the authorities to know what citizens were dangerous, or even simply too influential, so that they might be regarded with suspicion, and arrested on the first pretext.

Not only was the Belgian administration completely deprived of executive power, but the powers of the provincial councils were gradually undermined. In 1915 the right of meeting in ordinary session on fixed dates was taken from them, while the *députations permanentes* (administrative bodies appointed by the provincial councils from among their members) were placed under the direct authority of the presidents of the German provincial civil administration. Still further, from 1917 onward these presidents in each province were authorized to assume themselves the powers of the provincial councils as regarded the receipts and expenditure of the annual budget, and the methods of raising the necessary funds to meet the expenditure. The struggle between the provincial councils and German authority became bitter indeed when the governor-general claimed their collaboration in assessing liabilities for the enormous war-tax—varying between 40, 50 and 60 million francs per month—with which he had saddled the country. Nearly all the provincial councils refused coöperation, preferring to accept an arbitrary assessment decreed by the government of occupation, rather than to yield a semblance of legality to its decisions. Henceforward the military governors, and also the German presidents of civil administrations, were empowered to ensure the payment of the tax, and to that end had the right of raising loans in the name of the province. On July 6 1918 the provincial councils were definitively suppressed. Nothing then remained of the Belgian administrative system.

In vain, however, did Germany destroy the machinery of the country's self-government; she could not break the spirit of the nation. The glorious example set by men like M. Visart de

Bocarmé, burgomaster of Bruges, who at 80 years of age stood up fearlessly to the German military power, or like M. Max, burgomaster of Brussels, who boldly led the resistance of his townfolk, going so far as to post on the walls an official contradiction of the news published by the Germans concerning the march of military operations, from the earliest days of the occupation sufficiently indicated to the invaders what the public attitude was going to be. M. Max, when arrested and sent to Germany, there to be subjected to a system of reprisals, had for successor M. Lemonnier, whom in his turn the Germans were obliged to arrest and deport. In every class of society acts of admirable devotion occurred. Hundreds of Belgians were deported to Germany or shot. Names such as those of Gabriëlle Petit, Philippe Baucq, the Englishwoman Edith Cavell, J. Corbisier, Louis Neyts, Bodson, Le Grand, Lenoir and many others stand for the heroism of an entire population.

Neither deportation nor executions could ever prevent the spying on behalf of the Allies carried on by thousands of Belgians, nor the publications of a secret press which fought energetically against the occupant power. On Feb. 2 1915 *La Libre Belgique* appeared. Each week until the Armistice it was published and distributed throughout Belgium. At Louvain the *Revue de la Presse* gave the most interesting extracts from the Allied press. In Brussels *L'Amé Belge* made vigorous political propaganda; continuing to appear despite the arrest and imprisonment of its editor. In 1918 *Le Flambeau*, by the method of analyzing foreign politics, taught the public why to expect victory. At Ghent *L'Aube Cloche* stood firm against the Germans and against Activism, as did *De Vrije Stem* at Antwerp. Besides these journals, directed by secret committees of priests, lawyers, university professors and journalists, other smaller papers; appearing less regularly, such as *La Soupe*, *Le Belge*, *Ça et Là*, *Patrie*, and *De Vlémische Leeuw*, sustained Belgian patriotism.

*German Legislation.*—German legislation was abundant, more especially that of a repressive type. The most trivial regulations carried penalties of extreme severity. Maximum prices, requisitions of bread and cereals, were enforced by penalties extending to five years' imprisonment and a fine of 20,000 marks. Such Draconian measures were not imposed for the sake of the German army's safety; they applied only to the country's internal organization, martial law reigning over all that directly affected the army.

Military tribunals, without any intimation to the public of their creation or of their competence, were charged throughout the country with the application of these new laws. These courts afforded no security to those amenable to their jurisdiction, their procedure was neither public nor contested; the *dossier* not being even shown to the defence, they constituted a purely arbitrary means of government, not a judicial authority.

Along with these military courts von Bissing established by an order of Feb. 5 1915 a judicial system of two degrees. The German governors set over the Belgian provinces were given unlimited power of instituting penalties. Heads of *arrondissements* and commandants were empowered to institute penalties amounting to three weeks' imprisonment. Besides being thus granted legislative powers, these functionaries were authorized to try persons who disobeyed their regulations, the governors sitting as judges of appeal from the judgments of their subordinates. This edict, conferring as it did judiciary powers on officials, opened the door to administrative tyranny, destroying the indispensable safeguard afforded by the separation of judicial and administrative authority. Still worse, this edict established for repressive purposes the principle that a penalty imposed on a guilty person could, should the judge so decide, be inflicted on some other person. Such a measure, permitting the penalizing of an innocent person, when the culprit himself was out of reach, annihilated the personal liberty of the inhabitants of the country. These penal powers were carried yet further by an order of Aug. 3 1917, authorizing the governors to sentence delinquents to total or partial confiscation of property.

Besides endangering public liberty and security these edicts illegally weakened the authority of the Belgian tribunals. At

sufficed for the government of occupation to publish an order concerning any offences, jurisdiction on which it wished to keep in its own hands, and obviously by that act Belgian justice was deprived of its rights, to the profit of German justice. The creation of these tribunals occasioned public protests from the bar of Brussels, as a result of which its president, the *Batonnier Theodor*, was deported to Germany. Even certain offences against common laws were selected by the German administration to be dealt with by itself instead of by the judicial system of the country; a *police des mœurs* (police of public morals) formed in all the large towns being given powers which Belgian law assigned to the public prosecutors and the Belgian courts alone.

But soon the administration of justice was completely taken over by the invaders. On April 7 1918 a permanent German judicial system was established by order in Flanders and Wallonia, their administrative separation having just been effected by von Bissing. The Belgian courts were replaced by German tribunals—*Kaiserliche Bezirksgerichte*—established in the different *arrondissements*. The judges, the public prosecutors and their staff, the recorders and clerks, all were exclusively German, appointed by the governor-general in accordance with the usages of German law. The language of these courts was German, their procedure was that of the German code. Usually one judge presided, but in cases where the authorized penalty exceeded five years' imprisonment sentence was pronounced by three judges. Procedure was rapid. The public prosecutor made all inquiries and perquisitions, and warrants of arrest were issued without preliminary judicial inquiry. The court dealt summarily with all affairs in which the authorized penalty did not exceed one year's imprisonment; in other cases procedure was by judgment. The court decided whether or not the accused should have the right of being defended, defence not being officially authorized save in cases tried by three judges. There was no appeal; and in all cases, immediately the sentence had been pronounced, the judge called upon the military authorities to put it into execution. In the case of a death-sentence the governor-general had the right of pardon. Judges were removable.

This edict, therefore, replaced Belgian judges by German judges, who, being removable, could not afford security. It abolished the right of appeal, and replaced Belgian procedure by German procedure. The accused found himself being tried in a foreign language, without the right of employing defence, or even of defending himself, the courts having power to set aside any evidence they chose to disregard. The Assize Court was suppressed; the jury, that indispensable safeguard of personal liberty, no longer existed. Thenceforward, the same tribunals dealt with misdemeanours and with crimes, inflicting all penalties, including that of death.

In issuing an order of such scope, the governor-general was acting as a legislator. The Belgian constitution, the judicial organization of the country, were abolished and replaced by German laws and judges. Belgium was being treated not as occupied territory, but as a conquered country.

Before describing the transformation of civil justice it will be well to glance at the principles which these German tribunals were established to apply. On Sept. 2 1914 Marshal von der Goltz enunciated in his proclamation the principle underlying the repressive system of an occupant power:—"It is a harsh necessity of war that the punishment of hostile acts falls on the innocent as well as on the guilty." The same principle is found again in the edict of Feb. 5 1915, authorizing the governors to decide that penalties decreed by the German courts of justice should in certain cases be transferred to other persons in default of the culprits themselves. The same principle was applied by a series of edicts empowering the German authorities to take hostages who should pay with their lives for damage done to railway tracks, to inflict heavy fines on communes, to deport the entire population of villages in whose area railway lines had been damaged, to punish whole families for faults committed by single members of them, to treat as guilty all persons found in company with anyone committing an offence. Again, the

Belgian was penalized for "not having done" or for "having had the intention to do." Counting on having its task facilitated by the citizens informing against one another, German justice proclaimed that not to give information constituted a misdemeanour, if not even a crime. That a person had "probably been cognizant of an infraction" sufficed to place him in the same position as the culprit, liable to the same penalty. Not only all who should aid, lodge, or feed the subjects of states at war with Germany, but even those who should not give information of their presence, were punishable by imprisonment or penal servitude. One sole mitigation is found: a wife who does not denounce her husband wanted by the German authorities may plead extenuating circumstances and is only liable to from 3 months' to 2 years' imprisonment or penal servitude. Again, every citizen was obliged, under pain of 3 to 15 years' penal servitude, to give information of the arrival in the country of any person belonging to one of the Entente nations, to denounce anyone making or storing munitions, to furnish all information in his power concerning British establishments in Belgium, to denounce anyone refusing to work for Germany.

Yet another new offence was that of being absent from Belgium and not having returned there within a period of two months. This offence was punishable by a fine fixed at ten times the amount of the taxes for which the absentee was liable. And besides new offences, new penalties were also introduced into Belgium by this German legislation. General confiscation of entire property, definitely forbidden by the Belgian constitution and by Article 46 of the Hague Convention, was decreed for infraction upon anyone not immediately denouncing to the German authorities persons placed under special surveillance; and upon persons under German police supervision who, being sentenced, could not be found and arrested. This penalty might be inflicted by the mere order of a governor. It may be added that this attempt on the part of the government of occupation to force the inhabitants of the country to denounce the activities against Germany of persons attached to the Allied armies contravened Articles 52 and 44 of the Hague Convention.

Deportation was introduced as a penalty in 1915 and was inflicted upon those who refused to work for the German authorities, also upon those who did not comply precisely with their obligations towards the police control. It is a fact that deportation was inflicted, even without trial, on persons who for any reason appeared undesirable to the civil or military authorities.

*Civil Law*.—Belgian civil law was also profoundly modified. On Feb. 3 1915 the Government of occupation abolished the decree of 10 *Vendémiaire an IV*, concerning the responsibility of communes in the case of pillage committed openly by force and accompanied by violence. At the moment of Germany's declaration of war against Belgium certain German establishments in the large Belgian towns had been sacked by the mob. The government of occupation deprived the Belgian courts of their competence to try these cases, establishing instead for the purpose a special arbitration court composed of three members—the president, appointed by the German governor-general, one member appointed by the president of the German civil administration of the province, one member appointed by the *députation permanente* of the province (Belgian administration). The presence of this single Belgian adjudicator afforded no security, the president being empowered to replace him by the president of the German civil administration.

Exceptional tribunals were also set up, supplanting the regular Belgian courts, to try cases of dispute concerning house rents. Belgian refugees abroad found themselves unable to enforce their rights in these new courts, the bar—always a special object of German hostility—not having access to them.

A general transformation of the judicial system was begun on April 7 1918. A complete system of German courts was established, comprising courts of first instance (*Bezirksgerichte*), and two courts of appeal (*Obergerichte*), that for Flanders sitting at Brussels, that for Wallonia at Namur. These "imperial tribunals" administered justice in the name of the German Emperor; their personnel was German, appointed by the governor-general;

their language was German. The courts of first instance were each presided over by a single judge, the courts of appeal by three judges. The Belgian bar was denied the right to defend persons tried before these tribunals. Such persons, if granted the assistance of counsel, had to apply to the *Juristatensmissor*, who assigned them a counsel for defence. These courts dealt with all causes in which a German or a neutral was concerned; they could besides declare their competences in other cases. They continued their functions until a few days before the Armistice. The administration of justice had now been taken completely into the hands of Germany.

*Attitude towards the Belgian Magistracy.*—From the first days of the occupation the German attitude towards the Belgian magistracy had constantly impeded the normal administration of justice. The German authorities were continually intervening, either to stop prosecutions at common law of Belgians in their own pay, or to prevent the application of repressive measures—rendered necessary by the conduct of the German soldiery—against the demoralization of minors; or to liberate prisoners on remand or after sentence, who were for some reason favoured by the government of occupation. The functions of *juges de pais* and *juges d'instruction* were alike subject to constant interference from German officials. Such violations of the independence of bench and magistracy raised vehement protests from the royal procurator, the procurator-generals, and the chief magistrates of the country. Conflicts ensued which often ended in the arrest of magistrates, judges, or royal procurators, and their deportation to camps of civilian prisoners in Germany.

Hostilities between the German Government and the Belgian magistracy became peculiarly bitter in Feb. 1918, when, conformably to Belgian law, the arrest was ordered of the Activists Bonn and Zack, promoters of the separatist movement in Flanders. The royal procurator of Brussels was at once ordered to set the prisoners free. Upon his refusal the German authorities employed forcè to liberate their protégés. At the same time the head of the German civil administration informed the Brussels Court of Appeal that its judicial activities must cease. As a protest the *Cour de Cassation* at once suspended its sessions and the entire judicial system of Belgium followed suit. Instantly the three presidents of the Brussels Court of Appeal, Levy Mouille, Ernst and Carez, were arrested and deported to Germany without trial. This final crisis of the struggle between the government of occupation and the magistracy is but one episode of Germany's attack on Belgium's unity, and even existence.

*Separation of Flanders and Wallonia.*—To disintegrate the Belgian nation was Germany's constant aim from the first days of the war, and the exploitation of the language differences of the country formed her chief means of pursuing it. Imagining that favour shown to the Flemish language would suffice to stimulate the separatist movement, the German Government adopted an attitude distinctly hostile to the use of French. In the *zones d'étape* of Flanders the military authorities totally discontinued the use of French in their public notices. The Censure only passed Flemish posters and advertisements. Finally the German Government announced its intention to transform the university of Ghent, whose language had hitherto been French, into a Flemish university.

These methods proving devoid of effect, they were succeeded by others more forcible in character. In 1916 various edicts abolished the official use of French in Flanders. From Jan. 1 1917 communications to the Government from that province and all official publications had to be exclusively in Flemish. In 1916 the Ministry of Science and Arts was divided into two distinct sections, one Flemish, the other Walloon, to prepare for the complete separation of public instruction in the two different linguistic regions.

It was on March 21 1917 that the German Government put into execution von Bissing's carefully elaborated scheme for the division of Belgium into two fragments, the edict running as follows:—"Two administrative regions are hereby formed in Belgium, one of which comprises the provinces of Antwerp, Limburg, East Flanders and West Flanders, with the *arrondis-*

*ssements* of Brussels and Louvain; the other the provinces of Hainault, Liège, Luxembourg, and Namur, with the *arrondissement* of Nivelles. The first region will be administered from Brussels, the second region from Namur."

A series of orders followed, organizing the separation. All ministries were duplicated, those for Wallonia being transferred to Namur. Language separation was complete. On Aug. 9 1917 Flemish was proclaimed the official language of Flanders, the use of French being forbidden to all bodies either administrative or charged with any public service. In Wallonia, on the other hand, Flemish and German remained authorized in communications between administration and public.

Although the Belgian nation as a whole regarded German legislative activities as unworthy of notice, and yielded no submission to this new administrative organization of their country, designed as it was to compass her ruin, yet the invaders were supported in the matter by a handful of Belgians who had passed into their service, and who claimed to represent Flemish public opinion. It was from these persons, who called themselves the "Activist party," that the Germans formed the "*Raad van Vlaenderen*," charged with organizing the new Flemish state, to be independent under German tutelage. That this council might have some semblance of legality there were to be elections in Flanders in Feb. and March 1918. As it was recognized that such elections, if honestly conducted, could only result in disaster for the German schemes, it was decided that the members of the *Raad van Vlaenderen* should be chosen only by such electors—an infinitesimal minority—as should be convoked by name for the purpose. The elections were to be by acclamation, held within closed doors, and under guard of German armed forces. Electoral meetings took place in Antwerp, Mechlin, and Tirlemont; they turned into patriotic demonstrations, and instantly the German Government forbade the continuance of the elections. On Feb. 11 1918 there was a huge demonstration in Brussels against separation. Delegates from over 1,000 associations—political, social, industrial, intellectual, and economic—met in the Grande Place with the object of presenting a solemn protest to the Communal Council. German troops dispersed the demonstrators. In all the towns of Belgium there were protests from the public bodies and great associations. In face of such an explosion of public feeling the German Government dared not confer on the *Raad van Vlaenderen* the legislative powers it had intended to give that body. A commission composed of the chief German civil authorities in Belgium and of exalted members of the German juridical world met at Brussels to study the subject of the formation of the Flemish and Walloon states. After months of work this commission decided that, as Belgian public opinion was utterly hostile to the separation, there could be no question of creating two independent states; but that, on the contrary, the new states must during a long transition period be placed under the authority of German governors, with the assistance in Flanders of the *Raad van Vlaenderen* as consultative council.

The *Raad van Vlaenderen* therefore, figuring as an emanation from the Flemish people, found itself empowered to choose from among its members 11 plenipotentiaries to form a permanent council which should participate, as a consultative body, in the exercise of that legislative power conferred on the governor-general. This tool in the hands of Germany was perfected by the addition of a Ministry of Defence, charged with raising in Flanders an army of volunteers, which was to fight at the side of the German army against the Belgian army.

At this moment the Brussels Court of Appeal intervened, issuing orders to the public prosecutor to arrest and prosecute the principal members of the *Raad van Vlaenderen*, who were accordingly immediately imprisoned by the Belgian police. This bold act had as consequence the arrest of the presidents of the Court of Appeal; and the conflict which ensued between the magistracy and the government of occupation resulted in the suspension of all sessions of justice throughout the country, despite the reprisals taken upon the chief magistrates. This solemn protest on the part of Belgian justice stimulated greatly the national movements of resistance.



The nation was further encouraged in its firmness of attitude by the protest of the communal authorities of Ghent, whose refusal to recognize the division of Belgium was answered by the arrest of the aldermen and the deportation of the burgomaster, M. Braun. Ghent was thenceforward administered by a college of aldermen appointed by the German governor-general, who reserved the right of controlling them and substituting himself for them in the exercise of their functions. A German military officer was appointed burgomaster of the town.

The government of occupation hoped to use education as a potent weapon for dividing the country. The Flemish language was proclaimed the only one permitted in the State and voluntary schools of Flanders. Even in Brussels, where French is spoken by a large majority of the population, Flemish was to be the only language of instruction. A transition period was conceded, but from Sept. 5 1918 primary education was to be completely Flemicized.

*Flemicizing of Ghent University.*—The centre of the whole scheme for the Germanizing of Flanders was to be the university of Ghent. It was to become a tool in the hands of Germany. Flemicization was decided upon in 1915 by the German Government and overtures were made to the professional body. On that body's refusal to submit to the invaders' desires reprisals began, Profs. Henri Pirenne and Paul Frodericq, accused of leading the resistance, being arrested and deported to Germany. The Ghent professors did not flinch before these intimidatory measures, but stood firm. On March 15 1916 an order was issued that thenceforward all lectures in the university of Ghent were to be given in the Flemish language. Professors who did not deliver their courses of lectures were to be placed on the retired list. The new university retained only four professors from the staff of the Belgian university, one of them a German. To fill its professional chairs it had to draw on students, members of the "Activist" party, Dutchmen and Germans. Shortly after, the German authorities celebrated the opening of the university, and the King of Bavaria graced the ceremony with his presence. A characteristic touch was the omission of Belgian history from the syllabus of the university. To attract students all the scholarships in Belgium were allotted to the university of Ghent, and a shameless campaign of intimidation was organized: students in the *sone d'Hape* were given the alternative of either being transported as forced labour to Germany or pursuing their studies at the "Activist" university. The latter alternative was backed by substantial advantages, extra food rations being added to the scholarship grants of money. Despite all this, and despite the suspension of lectures in all the universities of the country, not 200 students were recruited.

In 1917 the German authorities began to understand that Flemish opinion could not be counted on to aid in the dismemberment of Belgium, and consequently their treatment of the working-class population of Flanders increased in harshness, deportations becoming particularly frequent. But still attempts were made to foster Activist ideas. Lectures and meetings were promoted for the exposition of German views; the publication of pamphlets and tracts was facilitated; every form of autonomistic propaganda was supported by armed force. In the end it became obvious that no result would ever be achieved by these means, so a new form of propaganda was adopted. At Courtrai an association was formed with the name of *Volksopbeuring* (regeneration of the people). Its supposed object was to raise the moral standard of the Flemish people and relieve distress. It was supported by a committee in Holland consisting of the most exalted personages. In reality it had no other aim but to promote the idea of Flemish autonomy. Its activities were ignored, and remained without result until the day in 1918 when the German Government transferred to it the responsibility, till then belonging to the communal authorities, of distributing sugar, syrup, jam, potatoes, butter, etc. Thenceforward, the whole population of Flanders being forced to apply for those necessaries to the *Volksopbeuring*, propaganda could be made in terms of food, and constraint be exercised directly on each individual through the distribution of the necessaries of life. To

make this organization quite omnipotent the Government was further inspired to entrust it with the distribution of the home-grown food supplies. Resistance to anti-Belgian propaganda would then have been reduced by starvation. This project, however, produced such a fury of indignation throughout the country that the foreign legations were moved to protest and succeeded in preventing its realization. The true rôle of the *Volksopbeuring* had become so flagrantly apparent that in 1918 it was dhasowed by the Dutch committee which had been formed to support it.

*The Economic Situation.*—The occupation of Belgium by the German army profoundly disturbed the country's economic situation. Industry suffered from the very outset, owing to the measures taken for military reasons. Raw materials were at once requisitioned, and to facilitate that the declaration of stocks was made obligatory, while they might not be disposed of without permission. In Dec. 1914 the declaration was made obligatory of stocks of benzine, petrol, alcohol, glycerine, oils, fats, carbides, india rubber and pneumatic motor tyres. On Jan. 25 1915 this order was extended to stocks of lead, copper, aluminium, antimony, zinc, nickel, mercury, tin and alloys of metals.

Besides requisitions, other measures threatened and destroyed Belgian industry. On Nov. 26 1914 commissaries had been appointed by the German Government to supervise industrial or business concerns belonging wholly or in part to nationals of countries at war with Germany. On Feb. 17 1915 this supervision was changed into sequestration. All such undertakings, whether Belgian or foreign, were sequestrated if they could be useful to Germany or if they might be harmful to her. They were temporarily taken out of the hands of their proprietors and their management assumed by the government of occupation, which either continued to work them in the interests of Germany, or proceeded to liquidate them. Over 100 industrial concerns were sequestrated in 1915, about 20 in 1916, about 20 in 1917. They were great metallurgical works, building works, stone quarries, collieries, electrical generating stations, etc. Foreign undertakings, principally British ones, were put into liquidation.

The establishment of central depots for the monopoly of coal oils, fats, water, gas and electricity completed the capture of Belgian industry by the invader. In Oct. 1914 the Belgian collieries resumed work. On April 24 1915 the government of occupation established the *Kohlentrals*. Collieries had to send their entire output to the "Central," excepting only what was consumed in their own works. Contracts for deliveries existing at the moment of the publication of the edict were annulled. The *Kohlentrals* was intended to provide coal for the railways and the German army. This object rapidly expanded, and the "Central" became an instrument of official pillage.

The obligation to declare stocks was imposed simply to facilitate requisitions. In Oct. 1914 Germany introduced into Belgium a double system of requisitions: on the one hand, requisitions made directly for the army and the military authorities; on the other hand, general requisitions. The scheme for working them had been framed by Dr. Rathenau, who was entrusted with the creation of the "Department of raw materials of war" at the War Office in Berlin. Such raw materials were first seized, and could no longer be sold save to the "Centrals" which fixed their price. If the vendor refused the price offered he was expropriated, and handed a requisition voucher. From 1915 onward requisitions of raw materials and of machine-tools were made throughout the country. Belgian industries, deprived of raw materials, protested vehemently to the government of occupation that the requisitions should at least be paid for. They were told in reply that if the war tax of 60 millions per month was regularly paid, the price of requisitions would be paid in cash from Jan. 1 1915. This promise was never fulfilled, a thousand pretexts for delaying the payments being offered: difficulties in transporting and classifying the goods, and in checking the requisition vouchers; disproportion between claimed value and the real value; the necessity of not allowing German specie to leave Germany. Moreover, Germany never regarded herself as responsible for the price of the requisitioned goods;

she said they would be paid for by Belgium after the war. The impossibility, however, for Belgian industry to go on without capital obliged the governor-general to seek some solution. On April 2 1915 a *Caisse de prêts* (loan bank) was established at Brussels to make advances on the security of the requisition vouchers. For requisitions made by the army, prices were fixed by the military authorities; for other requisitions valuation was made by the indemnity office in Berlin. The *Caisse de prêts* might advance 75% of such valuation, if the claimant accepted the price offered. The *Caisse de prêts* merely gave a voucher, which the *Société Générale de Belgique* was required to cash; the latter in return being granted by the Reichsbank a credit equal to the sums disbursed, but not to be drawn upon until three months after the signature of peace. The *Société Générale* vigorously resisted this measure: on the one hand, because the payment of the enormous number of German requisition vouchers must produce an inflation of the fiduciary circulation, with the immediate result of raising the cost of living and increasing poverty; on the other hand, because the *Société Générale* objected to helping Germany in her requisitions. The *Société Générale* never consented to cash any vouchers save those issued for requisitions of raw materials. As claimants usually refused to accept the prices fixed by Berlin, the total of the loans granted did not exceed 75 millions of marks.

Requisitions were not confined to industry alone. In all private houses objects of copper, bronze, metal alloys and wool mattresses were seized. The following table shows the requisitions made in the area of General Government during the second half of 1917:—

Objects.	Quantity requisitioned during second half of 1917.
Copper and alloyed metals from private houses	2,069,300 kgm.
Copper from industrial establishments	3,975,800 "
Zinc	38,870,854 "
Lead	3,957,970 "
Tin	6,800 "
Steel	21,000 "
Iron from demolitions	140,000,000 "
Copper	5,576,375 "
Sulphate of copper	481,414 "
Lead (different forms)	12,309,842 "
Rough zinc	6,225,147 "
Cadmium	768 "
Silver	3,197 "
Chemical products:—	
Sulphuric acid	20,877.7 tons
Soda	6,065.0 "
Chloride of lime	570.0 "
Muriatic acid	886.5 "
Paper	270.0 "
Skins of large cattle	151,664 pieces
" calves	60,624 "
" horses	12,868 "
" sheep	27,710 "
" various animals	173,710 "
" rabbits	1,227,819 "
Tanning-materials	4,987,000 kgm.
Leather and leather straps	{ value of 4,915,000 mk. }
Boots and shoes	{ " " 4,251,955 " }
" " wooden soled	{ " " 79,948 " }
" " baskets	800 tons
Osier fibre	165 "
Wool and hair	840,270 kgm.
Mattress wool	831,685 "
Wool yarn	200,273 "
Woolen rags	1,748,261 "
Cotton rags	5,009,772 "
Manufactured cottons	301,032 "
Cotton and cotton thread	3,152 "
Cottons, confiscated, various	36,694 "
Manufactured flax and products	224,014 "
Hemp and jute	5,748 "
Cocoonits and piassava	150,112 "
Brushes	916,333 pieces
Strings	171,119 kgm.
Transmission cables	8,424 "
Jute bags	574,173 pieces

Up to June 1918 there had been requisitioned:—

290,000 tons of iron  
 7,000 " " copper from factories  
 3,500 " " " private houses  
 9,500 " " " copper produced in Belgium  
 7,000 " " " lead  
 24,000 " " " in different forms, produced in Belgium  
 35,000 " " " zinc  
 and also 8,550,330 marks worth of leather and leather straps.

Producers were obliged to deliver their total output to the "Central" at very low prices. The "Central," after having supplied the army and the railways, resold the surplus at very high prices to the factories which were authorized to work. Two offices for the distribution of coal to the Belgian population were established at Brussels and Namur, but the quantity allotted for this purpose was quite insufficient. Indeed, the *Kohlensentrale* tried to export as much coal as possible to neutral countries, for the sake of the large profits realized in that way.

In 1915 the export of Belgian coal to Germany reached 115% of the pre-war figure, in 1916 95%, in 1917 25%. Germany, on her side, imported approximately equivalent amounts of coal into Belgium.

The export to neutral countries was much greater, being in 1915 100% of the pre-war figure, in 1916 230%, in 1917 falling to 90%. The exportation of Belgian coal seemed to Germany a lucrative operation. At the meeting of the Economic Commission on June 29 1915 Kardoff, representing German trade, declared:—"The coal production of Belgium must first supply military requirements and afterwards Belgian consumption. The surplus must serve German purposes, notably as an export to neutral countries." This was the accepted doctrine.

In 1917 the distribution of Belgian coal was as follows:—

	1st quarter.	2nd quarter.	3rd quarter.	4th quarter.
Belgian population and authorized industries	53.0%	43.50%	44.50%	46%
Troops and railways	37.5%	47.50%	49.75%	52%
Occupied French territories	0.5%	0.25%		
Export	9.0%	8.75%	5.75%	2%

Military needs absorbed 4,665,975 tons, one-half of the total output. Thanks to the *Kohlensentrale's* monopoly, the profits realized by it were large. The figures are as follows:—

Profit on sales.	1915 marks.	1916 marks.	1917 marks.
In Germany	972	48,619	176,110
" Switzerland	340,892	5,856,376	3,498,449
" Scandinavia	1,688,646	10,547,467	2,557,033
" Holland	705,693	5,542,120	2,956,870

The total profits for the three years amounted to about 34 millions of marks, which were used as a German war loan.

An oil "Central" on the same model was established on June 3 1915. It realized a profit of 11,815,266 francs in the years 1915, 1916, 1917; 6.5 millions of which were for 1917 alone. Finally, on July 26 1915 the "Central" for water, gas and electricity was instituted, important services thus being placed under the direct control of the German administration.

The German Government now controlled all the elements indispensable to industry. Henceforth no undertaking could escape its power. Industry was forced into absolute submission to the terms imposed by the invader.

The Belgian marine export trade had, of course, been stopped by the war. Belgian factories closed down one after the other and the numbers of unemployed quickly became enormous. The *Comité National*, whose activities will be described later, organized relief measures, got work of public utility started, and established *bourses de travail* (labour scholarships), which, while supporting the unemployed person, exacted meantime his attendance at technical classes. The German authorities intervened in 1915 and opposed this great organization for assisting the unemployed.

It was soon realized that the only efficacious method of helping the Belgian masses was to revive trade, and in Aug. 1915 a

*Comité Industriel* was formed for that object. It entered into negotiations with the Allied Governments in order to obtain permission to import raw materials into Belgium—such raw materials, once manufactured, to be re-exported and the proceeds realized applied to the purchase of foodstuffs necessary for the victualing of the Belgian population. The Allies were willing to agree to such an arrangement, but the German Government made the condition that payments for the exported goods should be deposited in a Belgian bank. England declared that she could not accept such a condition, which would have meant that the Allied Powers would be helping Germany, so the *Comité Industriel* dissolved without having achieved anything.

The numbers of the unemployed became daily more alarming. In 1916 they reached 650,000. On Oct. 16 1916 the *Comité National* made a fresh attempt to revive trade, proposing the authorization of exports, their proceeds to be handed to the Commission for Relief in Belgium as payment for food sent in return. Germany refused consent. Part of Belgian industry still remained active but the factories sequestered by the enemy had great difficulty in finding labour, considerable numbers of the working-classes obstinately refusing to work in the interests of Germany. On Aug. 14 and 15 1915 appeared the first edicts instituting severe penalties for those refusing to undertake work for the German authorities.

The government of occupation was also undermining Belgian industries by requisitions of machinery and tools. Commissions of German engineers and heads of industry were sent into Belgium to seize from Belgian factories any machinery which could be utilized in Germany. The real object was to destroy Belgium's trade, as being a dangerous rival to that of Germany. Pure vandalism characterized these requisitions, the experts even destroying machinery which they found it impossible to remove.

Again official orders of Jan. 10 and Oct. 10 1916 forbade more than 24 hours work per week in the textile and boot-making trades; and those of Feb. 17 and July 21 1917 forbade work in all workshops and factories of Belgium save by authorization of the president of the civil administration.

The working-class population of Belgium was reduced to beggary. The masses of unemployed became more and more numerous. Germany desired them more numerous still. Public works started by provinces and communes to provide employment were suddenly prohibited. Germany exposed her hand.

The president of the civil administration expounded the German theory in a speech delivered before the *députation permanente* of Luxemburg. Relief of the unemployed, he said, was inadmissible in the case of persons deprived of work by the German regulations. Workers aged from 18 to 50 could go to Alsace-Lorraine or Germany, and work there for good wages. If able-bodied members of the working-class would consent to go to Germany, communes would be once more authorized to provide public work for the unemployed of under 18 or over 50.

Thus, by means of a skillfully planned series of edicts, Germany had attained her object—had completely ruined Belgian industry and had created an unemployed class of nearly 700,000 workers, whom she forbade the public bodies to provide with work. Nothing remained but to transport this potential labour into Germany.

From 1917 onwards Belgian industry was subjected to systematic destruction. By June 30 1918, 167 factories had been completely destroyed, 161 factories were mentioned by the administrative report to the governor-general of the section for commerce and industry as to be destroyed immediately, 93 large halls were being demolished, others had been cleared out, 52 halls were to suffer the same fate. Of the 57 high furnaces existing in Belgium, 26 had been razed to the ground, 20 were seriously damaged, 11 only remained fit for use.

The *Service de Récupération Industrielle* subsequently identified in Germany 24,308 Belgian machines and 89,635,640 kgm. of various kinds of plant. Machinery that could not be carried away entire, had been broken up by hammer blows and the pieces sent to Germany; 200,000 tons of iron, 7,000 tons of lead (coming

chiefly from the storing chambers for sulphuric acid) had been taken from the factories.

Metallurgical works, textile factories, chemical works, quarries (save those requisitioned by Germany), cemeteries, gun-foundries, works of public bodies—all were completely despoiled. The collieries alone, being indispensable to Germany, were spared. But when the German army was in final retreat measures were taken to destroy the mines completely. On Oct. 26 1918 orders were given for work to cease in the coal-fields of Hainaut. On Nov. 1 pits and machinery were mined, pumping and ventilation were stopped, boiler furnaces extinguished. This would have meant the putting of Belgian mines out of action for years. In face of such an act of vandalism the neutral Powers protested, threatening Germany with economic reprisals, whereupon pumping was recommenced, and the pits and machinery were spared.

In all this policy of destruction Germany had a double aim. On the one hand, she was ruining Belgian trade and eliminating future rivalry from that quarter; on the other hand, unemployment was being daily increased, hundreds of thousands were being thrown out of work, and she was provided with a pretext for requisitioning human labour as she had already requisitioned raw materials and machinery. A series of edicts now prepared for that.

*The Deportations.*—In Oct. 1916 the military authorities made the first requisition of men for work in Germany. At that time nearly a million persons were in receipt of public relief in Belgium. In Nov. burgomasters were ordered under heavy penalties to furnish the German authorities with lists of the unemployed receiving relief in their communes. In every case the enemy Government was met by refusal on the part of the communal authorities. The military authorities thereupon began a general requisition of able-bodied men throughout the country, whether unemployed or not. Notices posted in the communes ordered all men aged from 17 to 60 to present themselves at the *Kommandantur* in the town of the *arrondissement*. There the assembled men were paraded within double lines of infantry and cavalry. Non-commissioned officers next proceeded to designate those who were to be deported to Germany or to the zones of the front. These unlucky ones were immediately marched to the nearest station, put on a train, and sent under guard to Germany.

Generally speaking, the inhabitants of Flanders—the *zone d'étape*—were sent to the Yser front or to that in the north of France. They were set to work constructing railways, repairing roads, or digging trenches in the zone of fire. Many of them were killed by the Allied bombardment. Workers requisitioned from other parts of the country were concentrated in great camps at Münster, Altengrabow, Guben, Cassel, Meschede, Soltau and Wittenberg. They were ordered to sign labour contracts, and their obstinate resistance was met by the most inhuman methods of intimidation and coercion. Deprived of food, beaten—even with blows of the bayonet—left tied to posts in the snow for entire nights, numbers of them yet perished rather than work for the enemy. In the camps the "purveyors of men" came to take delivery of the human merchandise allotted to them, and distributed it to farms, factories and mines throughout Germany. The invincibly recalcitrant were sent to *Strafbataillonen* at the front, where they were treated like convicts. Such camps, that at Sedan for instance, were responsible for many victims. From time to time convoys of sick were sent back to Belgium; the lamentable state in which they arrived provoked a great protest movement through all the country.

The first voice to make itself heard was that of Cardinal Mercier, Archbishop of Malines. He addressed a protest to the governor-general against the inhumanity of the deportations. In particular he said: "I will not believe that the imperial authorities have said their last word. They will consider our unmerited sufferings, the reprobation of the civilized world, the judgment of history, the chastisement of God." On Nov. 9 1916 the members of the Belgian Parliament in their turn addressed a courageous protest to von Bissing and appealed to the neutral legations. On Dec. 16 the magistracy in its turn protested. In

Nov. Senator Magnette, Grand Master of Belgian Freemasonry, addressed a letter to German Freemasonry, in which he wrote: "The brutal and total suppression of personal liberty, a repetition of the most painful wanderings of Jewish history, the captivity of an entire innocent nation, which for over two years has given an example of marvellous calm, dignity, and patriotism—does not all this cry for vengeance, are you going to disregard it?" German Freemasonry made no reply, but M. Magnette was arrested and imprisoned.

The censorship prevented publication of these numerous protests, which would have encouraged national resistance. Cardinal Mercier determined to address the nation from the pulpit of Ste. Gudule, the cathedral of Brussels. There, on Nov. 26, he addressed the faithful, lashing with burning words the inhumanity of Germany, and exhorting Belgians to stand fast in resistance, in patriotism and in faith in their ultimate victory. The vast throng of his hearers received these words with indescribable enthusiasm.

Finally, on Feb. 14 1917, the most important members of the clergy, the *Comité National*, Parliament, the magistracy, the bar, the nobility, financial circles, etc., addressed the German Emperor in a letter at once dignified and firm, demanding the repatriation of the deported Belgians. The foreign legations still at Brussels—those of the United States, Spain, and Holland—also showed sympathy. Cardinal Mercier had appealed to the Pope, and on Nov. 29 1916 the Pope had approached the German Government on behalf of the victims of deportation, but without effect. The United States now protested to Berlin against such violations of the principles of the Hague Convention, and the Dutch legation did the same. At the time of the fall of Antwerp in 1914 the inhabitants of that town, terrified by the massacres of Visé, Dinant, Andenne, Termonde, Tamenes, Aerschot and Louvain, had fled *en masse* into Holland. The German Government had requested the Dutch Government to assure the Belgian refugees that if they returned to their country they would not be subjected by Germany to requisitions or any other molestation. On the representations of Holland the people of Antwerp returned to Belgium. Germany had now taken thousands of men from among them for deportation, and Holland could not but protest against such disloyalty to promises made to her. These interventions also remained without result, but at last the insistence of Spain, the country which was protecting Belgian interests in Germany, succeeded after a preliminary repulse in obtaining a compromise from the German Government. The Marquis of Villalobar, Spanish Minister at Brussels, proposed an arrangement by which Germany should engage not to deport more than 250,000 men, who should be chosen from the unemployed; to allow those of the already deported who possessed means of existence to return to their homes; to permit deported Belgians to correspond with their families and send them money; and finally, to place Belgian workers in Germany under neutral surveillance. Germany agreed to all these conditions except the last.

The neutral legations next intervened to effect the transmission to the governor-general of claims from families whose deported members should, by the terms of the above convention, be authorized to return to Belgium. These claims were numerous; in one month the Dutch legation received 33,000 for transmission.

The deportation policy had proved a disappointment to Germany. The exiles refused to work, and, when forced into a semblance of submission, met coercion with an inertia which rendered their labour valueless. The whole world's indignation at this return to slavery seemed to decide Germany on a movement of clemency. In reply to the letter of Feb. 14 from distinguished Belgians the Emperor announced that he would examine the matter with benevolence. It was speedily decided that the victims of deportation should be repatriated on June 1 1917, and Germany published this decision far and wide. It proved but a piece of abominable treachery. Numerous convoys of the deported did indeed return to Belgium, but soon after they were again summoned to the *Kommandantur*, and, under pain of being

deported anew, were forced to accept work in the requisitioned Belgian factories. Moreover, the authorities declared that the Emperor had not promised that Belgian workmen should not be deported into France, and many of the convoys which arrived from Germany were immediately sent off to the invaded French departments. A yet more hypocritical construction was put on William II.'s words. He had promised the repatriation of the deported Belgians, but once repatriated there was nothing against their being deported a second time as unemployed. So the deportation began again, only to be ended by the Armistice.

Statistics of the Deportations.  
Deported into Germany.

Total number	Age 18.	Age 18-50.	Age 50-60.	Age 60-70.	Age over 70.
57,718	3,412	33,423	807	9	5

Died during deportation in Germany: 1,304.

Deported to the *Zwei Arbeitsbataillonen* at the front.

Total number.	Age 18.	Age 18-50.	Age 50-60.	Age 60-70.	Age over 70.
37,541	5,118	31,281	1,080	59	3

Died during deportation at the front: 1,227.

Total number deported: 115,259.

Total of deaths resulting from bad treatment: 2,531.

Deported from each <i>arrondissement</i> .	To Germany.	To the zone of the front.
Brussels . . . . .	1,539	378
Louvain . . . . .	1,923	..
Nivelles . . . . .	5,609	..
Antwerp . . . . .	4,661	..
Mechlin . . . . .	1,992	30
Turnhout . . . . .	..	..
Mons . . . . .	314	..
Charleroi . . . . .	11,254	5,503
Tournai . . . . .	6,304	10
Tournai . . . . .	2,577	8,609
Ghent . . . . .	10	11,074
Audenarde . . . . .	11	8,509
Termonde . . . . .	736	8,936
Bruges . . . . .	4	1,323
Courtrai . . . . .	19	9,715
Turnes . . . . .	..	2
Ypres . . . . .	..	961
Liège . . . . .	5	..
Huy . . . . .	32	..
Verviers . . . . .	734	..
Tongres . . . . .	467	27
Hasselt . . . . .	2,246	49
Arion . . . . .	2,423	2,815
Larche . . . . .	1,169	12
Neufchâteau . . . . .	1,204	..
Namur . . . . .	8,607	36
Dinant . . . . .	2,883	2

*Feeding the Belgian Population.*—Belgium could not feed her population unaided. She did not produce above a quarter of her wheat consumption. Thus as early as Aug. 14 1914 the Belgian Government had rationed bread. By Nov. scarcity was being felt in Hainault; and in the following month the provinces of Limburg and Luxemburg and all the towns were short of flour, while the rural districts lacked coffee, salt, yeast, coal, petrol and soap. Prices began to rise sharply. The situation was the more critical because, the country once occupied, the German government had abrogated all measures already taken by the Belgian Government to ensure its food supplies. The public administrative bodies could no longer act; private initiative had to take their place. Everywhere committees were formed. At Antwerp a *Comité de secours* collected 2,000,000 francs for organizing relief to the necessitous; while a *Comité de ravitaillement*, formed by the communal authorities and including in its sphere of action the 82 communes of the fortified area, secured 10,000 tons of wheat, bacon and lard, 2,000 head of cattle, and 3,000 pigs. At Liège a *Comité d'alimentation* was formed to manage the provisioning of 23 communes. At Brussels the *Comité de secours du Luxembourg* endeavoured to succour those left homeless by the burnings and devastations of the German army. At Bruges and Ostend committees were formed to purchase wheat. Everywhere such organizations appeared, but they were impotent to save the country from the famine which menaced it, for the German Government, in order to exercise pressure on the Allies, declared

that, as the British blockade prevented it from maintaining the provisioning of Belgium, it had no further concern in the matter.

A central committee was formed in Brussels, consisting of persons of the financial world, presided over by E. Solvay, and under patronage of the ministers for Spain and the United States. It took the title of *Comité centrale des secours et d'alimentation*. An executive committee was appointed with M. Franqué as chairman, the first meeting taking place on Sept. 3 1914. It at once opened canteens and food depots, obtaining through the good offices of neutral ministers a guarantee that they would not be seized.

But by Sept. 1914 famine was already imminent. The *Comité centrale* tried to get food from England; the British Government objected. Active negotiations procured an agreement: Marshal von der Goltz promised to exempt totally from requisition food so imported; the British Government on their side consented to the importations on conditions that the supplies should be conveyed to the Belgian frontier under patronage of the ambassadors of Spain and the United States, and that once in Belgium they should be under the patronage of the Spanish and American ministers at Brussels. The Commission for the Relief of Belgium was constituted to organize this scheme. The importation of food supplies now made the *Comité centrale* a body of great importance, and its activities extended all over the country. In each province a *Comité d'alimentation* was set up, its president sitting on the *Comité centrale* in Brussels. The *Comité centrale* now took the name of *Comité national des secours et d'alimentation*.

Permission to import food was not enough, a method must be found of paying for it. Von der Goltz would not allow money to be transmitted to the Allies; funds must be procured outside Belgium. The Belgian Government and the British Government each opened a credit of £100,000 to the C.N. The *Société Générale* put its own foreign credits at the C.N.'s disposal. A consortium of bankers and of the firm of Solvay et Cie. provided a loan of 15 million francs in gold, advanced by the London branch of the *Banque Nationale de Belgique*. In addition donations to the amount of 60,000,000 francs were collected in Belgium itself, and zealous propaganda was made abroad with the result that 60,000,000 francs were collected in England, 30,000,000 in America, 10,000,000 in other countries.

Huge quantities of foodstuffs had to be imported; 60,000 tons were needed every month, which implied at the same time 180,000 tons purchased, stored, or in transit, representing a value of 70 to 80 million francs. The funds at the C.N.'s disposal were insufficient. True, the proceeds from the sales of the imported goods would have balanced expenses, but the German Government would not allow money thus received by the C.N. to leave the country. An arrangement was therefore made between the C.N. and the Belgian Government, whereby the C.N. undertook to pay the salaries of the Belgian officials, while the Belgian Government in return paid over monthly an equivalent sum to the Commission for Relief in Belgium. This sum was fixed at 25,000,000 francs per month, but that proved insufficient, and in Jan. 1917 it was augmented to 37,500,000 per month. Just then; however, the submarine war stopped importations for several months, and the price of foodstuffs rose enormously in consequence. Moreover, the transference to Belgium of 150,000 French refugees who had to be supported by the C.N. further exhausted the latter's resources. New measures became necessary. The Belgian Government concluded an arrangement with the American Government, by which the latter gave 15,000,000 dollars per month to the C.R.B. to pay for purchases of food made in the United States. For purchases made in Holland the C.N. obtained use of the credits possessed in that country by all Belgian banks.

The functions of the C.N. did not consist in merely securing the arrival of supplies of food in Belgium, but also in distributing them throughout the country, and in those districts of northern France whose provisioning it undertook in 1915. The essentially private character of the C.N. and the refusal of the German authorities to allow it to organize a *police de surveillance* to safeguard its activities, made the situation very difficult. It is

true that the *Cour de Cassation*, by authorizing the courts to punish persons who contravened the C.N.'s regulations, gave it valuable help; but its task was only rendered possible by its admirable organization. At first decentral in system, the C.N. was forced by events to centralize. It was worked by its executive committee, whose president, M. Franqué, possessed the widest powers. He in fact directed the vast organization, assisted by a general secretary. The C.N. was divided into two departments: the *département d'alimentation*, responsible for provisioning the country, and the *département des secours*, responsible for relief measures. These two departments worked in close collaboration with the Commission for Relief in Belgium, formed in London in Oct. 1914, under direction of Mr. Hoover, and under patronage of the Spanish and American ambassadors at London, Paris, Berlin, Brussels, and The Hague. The C.R.B. had offices in New York, London, Rotterdam and Brussels. The three first effected the purchases for which they received orders from the C.N., the fourth supervised the distribution in Belgium.

The *département d'alimentation* had a subsidiary department for the study of alimentary questions, and another for inquiry into the needs of the country. Guided by these it gave its orders to the C.R.B., received the goods, and distributed them among the provincial committees. The vast scope of its functions necessitated the creation of a goods book-keeping department and a financial book-keeping department, also the putting under public control of the manufacturing processes applied to some of the materials received.

To show the magnitude of its task it may suffice to mention that up to Dec. 31 1918 it had delivered food to the provincial committees to the value of over 3.5 milliards of francs, 2.5 milliards having been for Belgium and one milliard for France.

A bonus was deducted from the sales of goods and paid over to the *département des secours*. The German authorities showing signs of intending to assume a share in the control of these sales, the C.N. asked the C.R.B. to deduct the bonus, so that it should escape German surveillance. Thanks to these bonuses, to which were added the voluntary donations from foreign countries, the *département des secours* accomplished a vast amount of relief work. A commission for the purchase of clothing and materials, with workrooms for cutting and making and for the training of apprentices, also with technical courses for students, supplied the provincial committees. Grants of money were also given; up to Dec. 31 1918, 1.3 milliards of francs had been distributed to the necessitous poor. This department gave grants besides to the societies for aiding officers' and non-commissioned officers' wives, families deprived of means by the war, the unemployed, and the lacemakers, to the societies for providing food for infants, succouring war orphans, the homeless, foreign refugees, artists, wounded soldiers, etc. Under its patronage were the *Société coopérative d'avance et de prêts* (formed to help State officials and employees), the *Société des habitations ouvrières*, the *Ligue contre la tuberculose*, the *Union des villes et des communes belges pour venir en aide aux sans-abris sinistrés*, the *Agence de renseignements pour prisonniers et internés*, the *Cantine du soldat prisonnier*, the *Caisse du soldat belge*. From Nov. 1917 its scope was widened further by fusion with the society for the relief of unemployment.

Delegates from the C.R.B. took an active part in the work of the C.N. They attended the meetings of the provincial committees, and thus provided the necessary liaison between them and the central executive, which could not have been done by members of the C.N. as the Germans did not permit them to travel about freely. The collaboration of the C.R.B. was also valuable in regard to the transport within Belgium of provisions for the provinces. The C.N. placed the flotilla it had formed, of 137 vessels (45,000 tons) and of 29 tugs, beneath the flag of the C.R.B., thus avoiding requisitions.

The C.R.B. undertook the frequently necessary negotiations with the German and British Governments. The gravest difficulty ever encountered was when in 1915 the German authorities prohibited the C.N. from dealing with the distribution of the indigenous foodstuffs. These were to be distributed by the

provinces and communes and thus neutral control was eliminated while Germany was enabled to requisition Belgian produce in her own interests. Besides the crops 92,000 horses (out of 317,000), 560,000 head of horned stock (out of 1,879,000), 350,000 pigs (out of 1,494,000), 3,000 sheep, and 1,600,000 fowls were sent to Germany. To stop this England threatened curtailment of the food supplies for Belgium. This serious crisis was averted by the good offices of the C.R.B.

Upon America's entry into the war Mr. Hoover resigned his function on the C.R.B., after three years of devoted work. Holland replaced America, and the *Comité Hispano-Néerlandais* took up the task of the C.R.B.

*The Belgian Government during the War.*—The gradual occupation of the country by the German army compelled the Belgian Government to retire first to Antwerp, then after the fall of that town to Ostend, finally to Havre. Ministers accredited to the Belgian Government followed it there, except the Spanish Minister, the Marquis of Villalobar; the American Minister, Mr. Brand Whitlock; and the Dutch *chargé d'affaires*, M. van Vollenhoven, subsequently appointed Minister—these three remained in Brussels.

At the time of the Government's removal to France over a million Belgians were fleeing before the German armies to foreign countries: 200,000 took refuge in France, 100,000 in England, 700,000—including nearly the entire population of Antwerp—in Holland. Germany's assurances that Belgians who returned to their country should not be molested brought back the inhabitants of Antwerp, to suffer subsequently from deportations despite the promises of the governor, von der Goltz. Fifty thousand refugees remained in Holland.

The Government at Havre found itself faced by a gigantic task. The army, deprived of bases and depots, was without munitions, food supplies, or clothing. All had to be reorganized. Yet not for one moment were the Belgian field forces withdrawn from the front. To reinforce them the King appealed to Belgians residing abroad, and they formed a first contingent. Thousands of Belgians who had remained at home also responded to the call of their King, and managed to get out of Belgium despite the strictness with which the frontiers were guarded, the high-pressure electric wires separating Belgium from Holland, and the severe penalties decreed against those who joined the Belgian army. On March 1 1915, having succeeded in establishing the necessary centres of instruction, the Government called up all Belgians between the ages of 18 and 25 resident in non-occupied Belgium, in France, or in England. On July 21 1916 all Belgians aged 18 to 40 resident in allied or neutral states were called to the service of their mother-country.

Colleges for officers were established in France—at Gaillon and Bayeux for infantry; at Onival for artillery; at Campagne for cavalry; at Ardres for engineers. Centres of infantry instruction were established at Parigné Lévêque, Auvoury, Honfleur, Granville, Saint Lo, Coutances, Carteret, Barneville, Valogne, La Haye-du-Puits. The artillery instruction centre was at Eu, that for auxiliary troops at Buchard.

On March 16 1915 a royal decree ordered the creation of building and repairing workshops, munitions factories, foundries, farrieries, storehouses, etc. Huge establishments improvised at Havre provided the army with all its artillery munitions.

Hospitals capable of accommodating all the Belgian wounded were provided at the front. A school of reeducation for the mutilated was established at Vernon. Belgian schools were started in France, England, and Holland. Necessitous refugees were helped.

Thanks to unremitting efforts the army was kept up at an effective average of 150,000 strong, and the field army at 75,000.

III. AFTER THE WAR.—When the offensive of 1918 brought liberation to Belgium the work of restoration to be accomplished was enormous. The Treaty of Versailles did not facilitate it. Shut out from the deliberations of the Supreme Council, Belgium could neither claim her rights nor defend her interests as, if represented, she would have been able to do.

For Belgium the most important question raised by the war

was the revision of the treaties of 1839. Those treaties had fixed the international status of the country by declaring it neutral in perpetuity under guarantee of the Powers. They had moreover mutilated Belgium by taking from her the half of Limburg with Maestricht, and giving it to Holland, and the half of Luxemburg, which was created a grand duchy. This mutilation gave Belgium frontiers impossible to defend—Maestricht forming a bridge-head on the Meuse, which was the country's natural line of defence. There was, further, pressing for settlement, the question of the Scheldt, that essential organ of Belgium's economic life; its estuary was in the possession of Holland, who could thus control the economic and military fate of Antwerp.

Nothing was done. Rather than take from Germany the ancient Dutch provinces of Guelders and Cleves, which would have served as territory to exchange for the cession of Limburg to Belgium, the Treaty of Versailles prevented a political and military solution of the Limburg question; while Holland on her side refused to solve it by a treaty of common defence between Belgium and the Netherlands. The grand duchy of Luxemburg was the object of French designs, which prevented its restitution to the mother-country. The question of the Scheldt was left hung up. Belgium only obtained two of the 14 Walloon cantons incorporated in Prussia in 1815—Malmédy and Eupen. She was also given the right to connect Antwerp with the Rhine by a canal.

As regarded finance, Belgium was relieved of her war debts (six milliards) to the Allies, who declared Germany responsible for them. Priority was granted to Belgium for a payment of 2.5 milliards from the German indemnity, this representing the reimbursement of 2.5 milliards extorted from her by Germany under the designation of war tax.

Belgium was left to seek unaided a solution to the grave problems which beset her. She entered on negotiations with Holland. These were going badly for Belgium; it seemed likely that the Scheldt would remain in Holland's possession, and that the defence of the eastern frontier would continue to be an insoluble problem, when Holland put forward a claim for recognition of her sovereignty over the pass of Weltingen—that is to say, over Belgian territorial waters from the Dutch frontier to beyond Zeebrugge. This manoeuvre—made possible by the isolation in which the Allies had left Belgium, and by the favour shown by England to Holland's doctrine that the Scheldt should be closed to Belgian warships—had for object, and would have entailed as consequence, Holland's right to deny Belgium access to the port of Zeebrugge, which would have meant that she was completely cut off from the sea. The general movement of protest throughout Belgium against the signature of such a Dutch-Belgian treaty compelled the Government to break off negotiations.

In 1918 Belgium joined with France in a treaty of defensive alliance, attempts being made to secure England's participation. As a result of negotiation France renounced in favour of Belgium her economic union with the grand duchy of Luxemburg.

As regarded Africa, Belgium did not succeed in gaining recognition of her rights over the territories conquered by her in German East Africa. Only Urundi and Ruanda were allotted to her; the other territories passed to England.

In the occupation of the Rhine Belgium was represented by a force of 12,000 men.

*The Work of Restoration.*—Internal problems were very grave. Before all it was necessary to ensure the food supplies of the country. This task was enhanced in difficulty by the fact that private enterprise could not touch it, owing to the sharp fluctuations of the exchange. The State itself was thus forced to purchase abroad the cattle, butter and margarine needed by the population. Maximum prices having proved inefficacious, a number of administrative orders were issued, forbidding speculation in foodstuffs, authorizing the requisition of indigenous products, establishing inspection to prevent vendors from adulterating goods, and repressing excessive prices.

The social situation was terrible. There were 800,000 unemployed; and 2,400,000 persons—a third of the population—only



exist by the aid of public relief. The State had to assume the support of these unemployed masses. Labour exchanges were established to facilitate the distribution of recruits to reviving industry. The vast numbers of the workless might have led to famine wages; to obviate this the State decided that any workmen offered less than the minimum rate of one franc per hour in the towns and 0.75 in the country, might refuse work, while yet continuing to draw out-of-work relief. Workers, moreover, were organizing themselves so as to improve labour conditions. The trade-union movement advanced with enormous strides. In 1919 the number of organized workers had risen to over 600,000, having been only about 200,000 in 1914. Wages, as a matter of fact, never fell below one franc per hour. Industrial workers in general have obtained two francs per hour, metallurgical workers earn 2.25 to 2.50 francs per hour, miners 16 to 20 francs per day.

The astonishingly rapid reconstruction of 2,000 km. of destroyed railway lines, effected by the end of 1919, the renewed activity of the collieries, which in the first quarter of 1919 produced 8.5 million tons of coal (against 11.5 million tons in 1914), and of the coke furnaces, which in May 1919 produced 58,000 tons (against 245,000 tons in May 1914), helped on the gradual revival of industry.

The *Commission de récupération industrielle* gave a first stimulus to industry by recovering Belgian machinery from Germany, and by 1919 huge orders from English and American firms had restored the country to economic activity. These orders were made possible by credits opened to Belgian industry by the banks. After the war the banks had indeed become of capital importance. The 13 principal banks of Belgium increased their capital by 380,000,000 francs.

In Dec. 1919 the output of the mines reached 81.3% of the pre-war output. The coal-fields of Limburg were becoming active; in 1919 the Winterslag mine began work, producing 500 to 600 tons per day, in 1920 a second mine was opened. The metallurgical industry achieved 20% of its 1913 output of cast iron, and 49% of steel and finished iron.

Alimentary industries, the building trade, industries of art and precision, were now employing 75% of their pre-war staffs, glass-making 80%, mines and transport over 100%, chemical industries, ceramics, paper-making, linen-weaving, tobacco manufacture 70%, clothing 87%, metallurgy 64%, the timber trade and furniture-making 66%.

Such a revival, effectuating itself in the midst of the gravest economic difficulties, could not but raise one problem after another. Questions of wages and of hours of labour were continually endangering relations between employer and employed. Thanks to a policy of foresight and moderation the Government managed to avert most of the conflicts. In April 1919 two commissions were appointed to inquire into the possibility of reducing hours of labour in steel manufactories and in mines. The principle of the 8-hour day was admitted. On June 1 1919 work was reduced to 8½ hours per day, on Dec. 1 to 8 hours per day.

In June another commission took up the same question for mechanical construction. Later, national councils were appointed for the public services of gas and electricity, for ice factories; the building trade, the timber trade, and furniture-making, glass-making, the textile trade of Flanders, and the port of Antwerp. The committees, presided over by officials, and composed of employers and employed in equal numbers, discussed questions of wages and conditions of work. They often passed resolutions constituting actual collective contracts, in some cases they proceeded to codify their decisions. They settled many local disputes, and checked movements dangerous to national life. The law does not enter into either their constitution or their functions; they have no means of enforcing their decisions other than the appeal to public opinion; yet there had not been one instance up to 1921 where resolutions passed by the committees had not been loyally applied. Employers and employed found in these bodies a means of discussing and solving problems which formerly would have been met by a strike. The establishment of these committees marks an interesting tendency towards the

decentralization of economic legislation, towards a professional organization quite outside political parties, towards the assumption by the worker of his share in the solution of industrial problems.

Since the war, as a general rule, wages had risen considerably, with a tendency towards uniformity and towards their fixation according to index numbers published by the Government. In Dec. 1919 the index number was 359 relatively to the month of April 1914.

Belgium's resumption of commerce after the war is shown in the following table in which the imports for 1919 and the exports for 1919 and 1920, from and to the chief regions in question, are shown.

	Imports 1919.		Exports.	
	Tons.	Thou- sands of francs.	1919 (tons.)	1920 (tons.)
Germany . . . . .	1,550,142	659,921	191,032	471,883
France . . . . .	2,087,273	1,850,476	2,213,875	3,885,704
England . . . . .	1,805,573	1,687,474	166,333	685,701
Holland . . . . .	623,868	585,098	1,931,946	1,491,553
United States . . . . .	900,804	1,547,808	223,364	317,961
Argentina . . . . .	394,165	519,954	5,044	52,656
Congo . . . . .	12,252	87,327	18,107	21,342

These figures show the war's disastrous effect on Belgian commerce. In 1914 exports and imports were fairly equivalent. In 1915 imports exceeded exports by about three milliards of francs. In 1920, it is true, the export trade to the seven countries named above began to revive, improving from 4,749,701 tons to 6,926,800 tons. But trade was involved in the gravest difficulties. Markets had been captured during the war by England and the United States. France's protectionist tendencies and Germany's easy rivalry in foreign markets owing to the depreciation of her exchange were also causes of the serious commercial crisis that Belgium was passing through in 1920-1.

The resurrection of the port of Antwerp was rapid. In 1919 4,820 vessels, registering 5,245,048 tons, entered the port; in 1920 7,698 registering 10,852,341 tons (in the same year Rotterdam received 5,951 registering 7,609,777 tons). Antwerp's development is closely linked with Belgium's prosperity. The port's connexion with the Rhine by means of a ship canal was in 1921 under consideration.

Belgium made great efforts to develop her commercial marine. The Lloyd Royal Belge, entirely promoted by Belgian capital, was formed to add to the Red Star Line's already existing service between Antwerp and America regular services to Brazil, the British West Indies, the Far East, Australia, Spain, Italy and the Near East.

But though Belgian commerce and industry were showing their powers of rapid recuperation, the country's financial situation could not but be serious. Scarcely was it back in Belgium when the Government had to face the cost of redeeming the marks put in circulation by Germany; the amount represented 7.5 milliards of francs. Other heavy charges upon State finances were: the payment of arrears of salary due to officials; the augmentation of salaries necessitated by the enormously increased cost of living; the expenses of victualling the country and of reconstructing railways, canals and roads; the sums voted for compensation to industrial concerns and private persons for war damage and destruction.

In 1919 the national debt amounted to 12,964,050,000 francs; in 1920 it was over 30 milliards. To meet a situation of such gravity new taxes had to be imposed. The income tax established by vote on Oct. 21 1919 took 10% on unearned incomes, and a graded percentage on earned incomes which only reached 10% when such an income was over 48,000 francs.

On Oct. 11 1919 a new law of inheritance imposed a tax varying with the heir's degree of kinship to the deceased from 1 to 50% upon the sum inherited; while inheritance from an intestate was suppressed in favour of the State beyond the fourth degree of kinship. New taxes fell on beer, tobacco, alcohol, and cinemas. On March 3 1919 war profits were taxed progressively up to 10% and railway fares were doubled.

Despite these efforts it was obvious that the Belgian budget could not be restored to financial equilibrium save by Germany's payment of the war indemnity. In order to have some guarantee of that indemnity the Government, on Nov. 10 1918, placed under sequestration all property belonging to subjects of the enemy countries. The chief item of expense was the indemnification of war damage, estimated at over 35 milliards. The State supported the formation of coöperative societies, advancing to persons who had suffered war damage up to 70 to 95% of the compensation due to them, and the creation of the Crédit National Industriel, also supported by the Banque Nationale, and serving as intermediary between the State and the claimants. To provide the advances these organizations issued 5% bonds guaranteed by the State up to the value of the compensation for damages. Thus the debt was brought into the hands of several groups, which should greatly facilitate its liquidation.

The work of national reconstruction was being accomplished up to 1921 amid political and social calm. After the Armistice the Government was composed of ministers belonging to the three great parties. All political strife had ceased, a truce having been brought about by mutual concessions. Universal suffrage "pure and simple" at 21 years of age was established at the demand of the Socialist party. As compensation the Catholic party claimed votes for women, which the Chamber conceded for communal elections but not for parliamentary elections. The elections of Nov. 16 1919, with universal suffrage at 21, deprived the Catholic party of the majority it had enjoyed since 1884, while the Socialists gained considerably.

Thanks to this political calm, Parliament was able to introduce such important reforms as the income tax, and the prohibition of the sale of alcohol in public (law of Aug. 29 1919).

The only disturbing elements in Belgian public life in 1920-1 was the Activist movement. Promoted by German intrigue during the war, it still existed, making the independence of Flanders its ostensible object. At the last election its candidates only polled 62,000 votes out of 1,757,704 cast, and it was generally condemned by public opinion. The members of the *Raad van Vlaanderen* and certain Activists who had assisted the enemy were convicted of high treason and sentenced, but they had escaped to Holland, where they were well received by both the Government and the public.

Belgium took an honourable part in the proceedings of the League of Nations. Like Brazil, Greece and Spain she was invited to join the Council along with the Great Powers, and her delegate, M. Hymans, was elected president of the first general assembly at Geneva. At that assembly Belgium was re-elected as member of the Council, to sit on it with Brazil, Spain, China, and the Great Powers. With the object of extending Belgian influence abroad, the diplomatic and consular services were completely reorganized. The *Association Internationale des Académies* has chosen Brussels for its centre of activity.

On Aug. 19 1920 the *Académie de la langue française* was inaugurated at Brussels. Dr. Bordet, professor of Brussels University, was awarded the Nobel prize. University life had revived. The civil status granted to the universities of Louvain and Brussels was on July 5 1920 extended to the universities of Ghent and Liège. The profits realized by the C.R.B. were presented by the president, Mr. Hoover, to the Belgian universities. Each of them was the recipient of a donation of 20 million francs, intended to develop the scientific side of their work. Mr. Hoover moreover presented a sum of 80 millions to the *Fondation Universitaire*, the income to be allocated by a committee of university professors to encourage the advance of science in Belgium.

Finally, mention must be made of the reform of justice, the creation of single judge tribunals, reforms in the treatment of prisoners, and the institution of a school of criminology. The Government established a school of agriculture at Ghent, a school of social service, and a colonial school. A commission of inquiry was appointed to investigate the violations of international law committed by the Germans in Belgium. Archives of the war were founded to collect all the documents relative to the history of Belgium from 1914 to 1918.

**BIBLIOGRAPHY.**—From the historical point of view:—H. Piragne, *Histoire de Belgique* (5 vols.); idem, *Les anciennes Démocraties des Pays-Bas* (English trans.); Cammaerts, *Belgium*. From the political point of view:—H. Van der Linden, *History of Belgium*; Van der Eecken, *A Short History of Belgium*; E. Descalle, *Charles Rogier*; P. Hymans, *Histoire parlementaire de la Belgique*; idem, *Frère Orban*; Van der Smissen, *La Correspondance de Léopold I. avec M. Beernaert*; Buffin, *La Jeunesse de Léopold I.*; *Le Livre gris belge*. From the economic and social points of view:—Seebohm-Rowatree, *Comment diminuer la misère en Belgique*; Levinaki, *Le développement industriel de la Belgique*; Waxweiler, *Enquête Industrielle* (published by the Ministère du Travail); H. Charriaux, *La Belgique Moderne*; Passetecq, *Les déportations des ouvriers belges pendant la guerre.* (H. P.; J. P.)

#### BELGIAN LITERATURE

It cannot be said that any very extraordinary new talent either in prose or in poetry revealed itself in Belgian French literature between 1910 and 1921.

The fame of Maurice Maeterlinck and Emile Verhaeren remained world-wide. Maeterlinck's play *L'Oiseau Bleu* (1912) was first performed at Moscow, then in London (translated as *The Blue Bird*), and later in Paris and New York. The writer's poetic imagination and serene philosophy contributed to make his play intensely popular. A continuation under the title *The Betrothal* was produced in London in 1921.

During the war Maeterlinck published, in 1916, a volume of articles he had written in various newspapers and lectures he had delivered in England, France and Italy, under the title *Les Débris de la Guerre*. He also wrote *L'Hôte Inconnu* (1917), *Le Miracle de St. Antoine* (1919), *Les Sentiers dans la Montagne* (1919) and *Le Bourgmestre de Stillemonde* (1920), a play dealing with the horrors of the German invasion in Belgium.

Emile Verhaeren's tragedy *Helène de Sparte* was first published in German, translated by Stephan Zweig, then in Russian, and appeared in French in 1912, when it was performed in Paris. Verhaeren's forcible and rather rugged style is perhaps not absolutely suited to the subject he treats. His poems, however, *Les Rythmes Souverains* (1910), *Les Villes à Pignons* (1910), *Les Fleurs du Soir* (1912), *Les Plaines* (1911) and *Les Blés Mourants* (1912), are as intense in feeling and vitality as his earlier work. Verhaeren's accidental death (he was crushed by a train in Rouen station Nov. 26 1916) was a great loss to Belgian literature. *La Belgique Sanglante* (1915), *Parmi les Cendres* (1916), *Villes Meurtries de Belgique* (1916), *Les Ailes Rouges de la Guerre* (1916) have been read and admired all the world over for their ardent patriotism and their righteous indignation as well as for their felicity of expression. These war poems will live wherever the French language is spoken.

In *Les Libertins d'Anvers, Légende et Histoire des Loistes*, Georges Eckhoud has told the story of the heretic sects in Antwerp in the 16th century. In this book Eckhoud, according to his custom, exalts his native city in her vices as well as in her virtues. Other books written by Eckhoud are *Les Peintres Animaliers Belges* (1911), and *L'Imposteur magnanime, Perkin Warbeck* (1914).

A tragedy in four acts by Camille Lemonnier, *Edémie*, set to music by Léon du Bois, was performed in Antwerp in 1912 with great success. The poem, written in blank verse, has all the charm of Lemonnier's vivid imagination and forcible style. Lemonnier died in 1913. His last book, *Au Cœur frais de la Forêt*, was published in 1914.

Albert Giraud's *La Frise Empourprée* (1912) is a collection of poems, in which their author remains faithful to the Parnassian tradition. In 1919 Giraud published a volume of poems, *Le Laurier*, written in Brussels during the war, and in 1920 *Eros et Psyche*.

Ivan Gilkin published in 1911 poems called *La Nuit*, the first of three volumes, of which the others were to be called *L'Aube* and *La Lumière*, and in 1920 a play in blank verse, *Le Roi Cophetua*.

Gregoire Le Roy, in his collection of poems called *Le Rouet et la Besace*, illustrated by himself, deals with the sufferings of the poor. *La Couronne des Soirs* (1911), *Contes d'après Minuit* (1913), and *Joe Trimborn* (1913) are collections of short stories.

Jean Dominique (pseudonym of Mlle. Marie Closset), whose volume of poems, *Le Puits d'Asur*, was published in 1912, is undoubtedly one of the most gifted of contemporary women writers. Mlle. Closset is a teacher and lives in Brussels. Another original and interesting woman writer, Neel Doff, has published *Jours de Famine et Délivrance* (1911) and *Contes Farouches* (1913).

A considerable number of books and poems dealing with and inspired by the war were published by Belgian writers in England and France during the war, as well as in Belgium itself after the refugees and soldiers returned home. During the German occupation Belgians had necessarily been debarred from publishing works inspired by their patriotic feelings. Besides Verhaeren's war poems, Emile Cammaerts' *Belgian Poems* (1915) may be mentioned.

Professor Pirenne's *Souvenirs de Captivité en Allemagne* (1920) are a notable contribution to Belgian war literature in prose. An interesting book which consists of a series of essays on the war and the German occupation, *L'Œil sur les Ostrogoths*, by Ernest Verlant, director of Fine Arts, may give as a record of the impressions of a subtle mind and a cultivated personality. A monthly review *Le Flambeau*, published clandestinely in Brussels during the German occupation, by Oscar Grojean, Henri Grégoire and Anatole Muhlstein, a young Pole, and which continues to appear, edited by Grojean and Grégoire, is without doubt the most interesting literary and political review in Belgium. Amongst contemporary writers and poets in Belgium may be mentioned: Fernand Séverin (*La Solitude Heureuse*, 1901); Max Elskamp (*Sous les Tentes de l'Exode*, 1921; *Les Commentaires et l'Épigraphie du jeu de Loto dans les Flandres*, 1914); Georges Raemackers (*Les Saisons Mystiques*, 1910); t'Serstevens (*Un Apostolat*); Blanche Rousseau (*Le Rabaga*, 1912; *Lisette et sa Panlouffe*, 1913); Glesener (*Chronique d'un petit Pays*, 1913).

In 1920 Crommelynck's play *Le Cocu Magnifique* created a sensation in Paris where it had a long run at the Théâtre de l'Œuvre. In Brussels it obtained more or less of a "succès de scandale." It deals with a case of pathological jealousy. Crommelynck's other plays are *Le Sculpteur de Masques* (1908) and *Les Amants Puerils* (1921). Other Belgian plays include *Kaatje and Malgré Ceux qui tombent*, by Paul Spaak; *Les Étales*, *Les Liens* and *Les Semailles* (1919) by Gustave van Zype, and *Le Mariage de Mademoiselle Beulemans* by Fonsen and Wicheler, a picture of the life of the lower middle class in Brussels.

In Flemish literature there has been marked activity. Stijn Streuvels, a nephew of Guido Gezelle, and by profession a baker at Avelghem, a village in Flanders, has made a considerable reputation both in Belgium and in Holland. His descriptions of rural life are both poetic and realistic, and he has been compared to Tolstoy, whose psychological subtleties and epic amplitude Streuvels however does not possess. His style is of rare perfection, and this remark applies to the whole of the modern Flemish school of writers. Streuvels's work, *Het Glorierijke Licht* (The Glorious Light), was written in 1913. In 1914 he published *Dorpslucht* and in 1920 *Genoeve van Brabant*, a historical novel.

Cyriel Buysse may be called the Flemish Maupassant. He is a realist. His works, which deal with the life of the people both in towns and in the country and, to a lesser degree, with that of the middle classes, form a complete picture of Flemish life. Buysse is passionate, robust, full of revolt and of pity, very human. His *De Vroolyke Thocht* (The Joyous Expedition), *Stemmingen* (Impressions), and in collaboration with Virginie Loveling, a popular woman author, *Levensleer* (Education through Life) appeared between 1910 and 1912. In 1915 Buysse published *Zomerleven* (Life in the Summer), a sort of diary, and in 1921 *Zoals Het Was* (As It Was). Maurice Sabbe's *De Nood der Barisesees* (The Plight of the Barisesees), *In 't Gedrang* (1915, a book about the war), and *'t Pastorie van Schaedrycke* (1919, The Little Pastor of Schaedrycke) and E. Vermeulen's *Herwording* (Renaissance), which deals with the life of the peasants in West Flanders, may also be mentioned. René de Clercq and Karel van de Woestyne are the most

typical Flemish poets of the present generation. René de Clercq proceeds directly from the inspiration of Guido Gezelle (1830-89). His poems are essentially popular, vigorous, full of life and good spirits, although through these one feels his tenderness, his pity for the misery of the Flemish peasants. He has published a volume of *Gedichten* (Poems). Karel van de Woestyne has a more complex personality. His poems are very varied in feeling, sometimes simple and direct, at other times complicated, full of metaphors. His sphere is that of the soul, and for him things are real in so far only as they partake of the spiritual life. It is necessary to add that there are contrasts in Van de Woestyne's nature which he does not always dominate, and which give a certain want of harmony to his works. A volume containing prose essays on Flemish painters and writers is *Kunst en Leven in Vlaanderen* (Art and Life in Flanders). A volume of poems is *De Gulden Schadden* (The Golden Shadow). In 1918 Van de Woestyne wrote a book in poetic prose, mystic and difficult, called *De Bestendige Aanwezigheid* (The Eternal Presence), and in 1920 a volume of poems *De Modderen Man* (of which the nearest translation is The Man of Clay), the first volume of a trilogy. A new Belgian Flemish writer of outstanding importance is Felix Timmermans who, before he became celebrated in Belgium and Holland, sold sweets in a little shop in his native town of Lierre. *Pallister* (1916) is epoch-making in contemporary Belgian literature. It is as forceful as Rabelais and yet tender and poetic, with a pantheistic feeling for nature: the ecstasy of a human being who incorporates himself with woods and streams, flowers and beasts, and who revels in every form of life. One may say that this book takes an important place in European literature. It had already reached 12 editions in 1921, and a French translation was then about to appear. Another book of Timmermans, *Het Kindchen Jesus in Vlaanderen* (1918, The Christ Child in Flanders), is a most poetical transplantation of the story of the childhood of Christ. This has already been done in Belgian French literature by Eugène Demolder. But whereas Demolder's book is full of literary devices Timmermans's comes as it were from the heart of the people. Another Flemish prose writer is Herman Teirlinck: *De nieuwe Uylenspiegel* (1920, The New Uylenspiegel), a fantasy; and amongst the best-known recent poets Auguste van Cauwelaert, Frits Francken and Daan Boens may be mentioned. Cyriel Verschaeve has written a dramatic poem *Judas*, and Eug. Schmidt a play *Het Kinder-nummer* (a turn performed by a child at a music-hall).

(L. VA.)

**BELL, CHARLES FREDERICK MOBERLY** (1847-1911); British journalist, was born in Alexandria April 2 1847, the son of a merchant. He was educated in England, but in 1865 went back to Egypt and engaged in business. He soon began sending occasional correspondence to the London *Times*, and from 1875 onwards devoted himself mainly to journalism. By 1880, when he founded the *Egyptian Gazette*, he had become the regular correspondent for *The Times* in Egypt. He also published *Khedives and Pashas* (1884); *Egyptian Finance* (1887) and *From Pharaoh to Fellah* (1888). In 1890 he was summoned to London to take the post of manager (nominally assistant-manager) of *The Times*, at a time when it had suffered heavy financial losses over the proceedings connected with the Parnell Commission (see 20.858). From that date he devoted all his masterful energies to the journal he served. When *The Times* Publishing Co. was formed in 1908, and the financial control passed from the Walter family to Lord Northcliffe, he became managing director. He died suddenly whilst at work in *The Times* offices April 5 1911.

**BELL, GERTRUDE MARGARET LOWTHIAN** (1868- ), English traveller and geographer, was born at Washington, Durham, July 14 1868, the eldest daughter of Sir T. Hugh Bell, Bart. She was educated at Queen's College, London, and Lady Margaret Hall, Oxford, where she graduated first class in the final school of modern history in 1888. She travelled extensively in the Near East, making a specially adventurous journey across northern Arabia in 1913-4 over a practically unknown route, whereby she obtained a knowledge of the country which

proved of great value to the British Government when information concerning routes was required for the advance of the British army into Palestine during the World War. In 1914-5 she was in control of a special department of the British Red Cross, occupied in trying to trace soldiers reported as "missing." From 1916-7 she was attached to the Admiralty Intelligence Office in Cairo. In 1917 she went with the military authorities to Basra and followed the army up to Bagdad, where she subsequently acted as assistant political officer, the first woman to occupy so important an administrative post. In 1918 she received the founder's medal of the Royal Geographical Society.

Amongst her publications are: *Poems from the Divan of Hafiz* (translations, 1897); *The Desert and the Sown* (1907); *The Thousand and One Churches* (with Sir W. M. Ramsay, 1909); *Palace and Mosque at Ukhaider* (1914). She is also the author of the *Review of the Civil Administration of Mesopotamia*, issued as a White Book by the India Office, Dec. 1920.

**BELLEW, HAROLD KYBLE** (1835-1911), English actor, was born in Lancs. in 1835. He first appeared on the stage in Australia in 1874; afterwards coming to London and acting for two years with Irving at the Lyceum from 1878 to 1880. He had the reputation of being the handsomest man on the contemporary stage. In 1888 he joined Mrs. Brown-Potter in a tour round the world, and for the last ten years of his life played romantic and modern comedy parts in the United States. He died at Salt Lake City, Utah, Nov. 1 1911.

**BELLOC, HILAIRE** (1870- ), British man of letters, was born near Versailles July 27 1870. His father was a Frenchman; his mother, an Englishwoman whose maiden name was Bessie Rayner Parkes, took an active share at an early date in the woman-suffrage movement (see 28,787). Educated at Edgbaston, he served as a driver in the 8th Regiment of French artillery before proceeding to Balliol College, Oxford. At Oxford he was prominent both in his schools and at the Union, and soon became known as a clever writer and speaker. He sat in the House of Commons for Salford from 1906 to 1910 as a Liberal. His very numerous writings include verse, children's books, essays, biography and fiction, as well as military history. Amongst them may be mentioned *Danton* (1899); *Robespierre* (1901); *The Path to Rome* (1902); *Esse Perpetua* (1906); *Cautious Tales* (1907); *Mr. Clutterbuck's Election* (1908); *A Change in the Cabinet* (1909); *Marie Antoinette* (1910) and *A General Sketch of the European War* (1915-6).

His sister, **MARIE ADELAÏDE BELLOC-LOWNDES** (b. 1868), who in 1896 married Frederick Sawrey Lowndes, a member of the staff of *The Times*, also became well-known as the author of numerous novels and striking short stories, including *The Pulse of Life* (1907); *The Uttermost Farthing* (1908); *Studies in Wines* (1909); *The Chink in the Armour* (1912); *The Lodger* (1913), etc. Dramatized versions of the last two, by H. A. Vaghell, were played in London as *The House of Peril* (1919) and *Who is He?* (1915). She published besides a biography of Charlotte Elizabeth, Princess Palatine (1889) and *Told in Gallant Deeds*, a history of the World War for children (1914).

**BELOW, FRITZ VON** (1853-1918), German general, was born Nov. 23 1853 at Danzig. He took part in the war of 1870-1 as a young officer. In 1912 he was appointed to the command of the XXL Army Corps. In this capacity he fought with the VI. Army on the western front at the beginning of the World War, but his corps was transferred in 1915 to the eastern front. In 1916 he was chief in command of the I. Army, which fought with success in Nov. 1916 on the Somme. He died in a field hospital on the western front in Nov. 1918.

**BELOW, OTTO VON** (1857- ), German general, was born at Danzig June 18 1857. At the beginning of the World War he was in command of the 2nd Infantry Div. at Insterburg in East Prussia. He was first of all promoted to the command of the I. Reserve Corps, and in this capacity took part in the battles against the Russian army of the Narv which resulted in the almost complete destruction of that army. He was then appointed to the chief command of the VIII. Army

which bore an essential part in the victory over the Russian X. Army at the battles of the Masurian Lakes (Feb. 7-19 1916). In May 1915 he was placed in chief command of the German Niemen army and pressed forward with it in Courland (Kurland) and Lithuania as far as the southern reaches of the Dvina. In the autumn of 1916 he received the command of the German army group in Macedonia and in the autumn of 1917 was placed in chief command of the XIV. Army, which was fighting against Italy. In 1918 he led the XVII. Army, which particularly distinguished itself in the battles around Arras. After the war he was for a short period general in command of the XVII. Army Corps at Danzig. He resigned in June 1919.

**BENCKENDORFF, ALEXANDER, COUNT** (1849-1917), Russian diplomat, was born in 1849. His family came from Livonia, one of his ancestors having been burgomaster of Riga. His great-uncle, who achieved great distinction in the Russian imperial service in the reign of Nicholas I., becoming minister of the police and being raised to the rank of a count, died childless, the title and estates passing to his nephew, Count Alexander's father. The mother of Count Alexander was a princess of Croy. He was educated in a private school in Paris and passed his *baccalaurat* in due course. He entered the diplomatic service in 1869 and began as an attaché in Florence, eventually in Rome. He resigned in 1876 and lived nearly 10 years on his estates, in St. Petersburg and abroad. He married in 1879 Countess Sophie Schuvaloff. In 1886 he returned to diplomacy and served as first secretary in Vienna under Prince Lobanoff-Rostovsky and Count Kapnist. In 1897 he was appointed minister in Copenhagen and remained there until 1903. The Copenhagen post gave him, as well as some other diplomats, an exceptional opportunity of watching the principal moving powers of European politics from a point of vantage, as the matrimonial alliances of the Danish royal family occasionally brought together in a friendly family circle the widow of Alexander III., Nicholas II. and the Prince of Wales who was to become King Edward VII. In this way Count Benckendorff received his initiation into the spirit of an Anglo-Russian *rapprochement* even before it actually resulted in an Entente. When he was promoted in 1903 ambassador to the Court of St. James as a successor to Baron de Staal, the atmosphere seemed anything but favourable to such a *rapprochement*. The rivalry of the two Powers in the East, cunningly exploited by the Kaiser, was growing more and more acute. When the storm had discharged itself in the Japanese war, reasonable statesmen on both sides, King Edward, Lord Lansdowne, and the Russian Foreign Minister Isvolsky, changed the course both for Great Britain and for Russia, and thus frustrated the plans of the *tertius gaudens*. Count Benckendorff had an important share in bringing about this change. At a very critical moment, when the Kaiser had actually mesmerized Nicholas II. into the conclusion of a secret and personal convention at Björkö, which purported to aim at a defensive agreement, but would have led by necessity to the disruption of the Franco-Russian Alliance and to the vassalage of Russia in a continental league against England, Count Benckendorff was invited to Copenhagen and had an opportunity of serving as a confidential intermediary between Russia and Great Britain. The Kaiser was exceedingly angry and gave vent to his feelings in a letter to "Nicky"—"Like brigands in a wood he has sent Benckendorff—your Ambassador—to Copenhagen on a clandestine mission to your mother, with the instructions to win her over to influence you for a policy against me. The Foreign Office in London knows about his journey, which is denied at your embassy there." Tsar Nicholas's reply to this letter shows in what esteem Count Benckendorff was held by his sovereign—"Benckendorff went by my permission as my mother invited him to come as a friend of the Danish family. What sort of conversation went on I certainly do not know. But I can resolutely assure you that nothing can influence me except the interest, safeguard, and honour of my country. Benckendorff is a loyal subject and a real gentleman. I know he would never lend himself to any false tricks, even if they came from the 'great mischief-maker himself.'" The Björkö intrigue evaporated without leaving any

frangible result, and the historic *rapprochement* between Great Britain, France and Russia took its course. Benckendorff in London was excellently placed to keep up and to develop this policy. Liberal, courteous, a shrewd observer, loyal and watchful in the cause of Russia, he maintained the best possible relations with Lord Lansdowne and Sir Edward Grey, and became a favourite at Court and in London society. He was peculiarly adapted for the wise and skilful treatment of difficult problems in the spirit of an international set. playing the great game of diplomacy with grace and honour. He had to face the dominant fact of the situation—the aggressive pressure of Germany at a time when Russia was drifting into an internal crisis of the first magnitude and was unable to concentrate the material and moral forces required in the coming conflict. Unpleasant retreats had to be effected twice, before the Kaiser “in shining armour”: the first time after Aehrenthal’s annexation of Bosnia-Herzegovina, the second after the blocking of the Serbian advance towards the Adriatic. Benckendorff was one of those who knew how to abide his time, and he did not lose heart. There were greater trials in store when the World War broke out at last. His younger son fell in one of the first battles on the East Prussian front, and he lived to see the collapse of the corrupt military organization of Russia in the campaign of 1915. Fortunately for him, he did not live to see the *débâcle* of Russian society in 1917. He died Jan. 11 1917. (P. VI.)

**BENEDICT XV. (GIACOMO DELLA CHIESA)**, Pope (1854–1922), was born at Genoa on Nov. 21 1854. In contrast to his immediate predecessor Pius X., who was of humble origin, and whose ministerial experience was mainly pastoral, Benedict XV. was descended from one of the most ancient of the noble families of Italy, and his work and training had been chiefly in the official or diplomatic service of the Holy See. His ancestors in the Middle Ages were enrolled in the patricians of Genoa, while other branches of his family followed the popes to Avignon in the 14th century, and eventually their sons took service in the army of the king of France, under the name of d’Église. His brother served as rear-admiral in the Italian navy.

Giacomo della Chiesa was educated in the seminary and at the university of Genoa, where he took his degree as Doctor of Law in 1875. Afterwards he went to Rome and studied for the priesthood in the Collegio Capranica from which he passed to the Accademia dei nobili Ecclesiastici, the usual training school for those who devote themselves to the “*carriera*” or diplomatic service of the Vatican. Here he became the friend and favourite of Cardinal Rampolla who, on being sent in 1883 as papal nuncio to Madrid, took Mgr. della Chiesa with him as his private secretary. He remained in Spain four years, and in 1887, when Leo XIII. recalled Cardinal Rampolla to make him his secretary of state, Mgr. della Chiesa returned to Rome in the suite of his patron, and was given the post of *minutante* in his department. In this, his work was the summarizing and inditing of the official letters and dispatches of the Holy See, combined with the functions of confidential secretary. As he discharged these duties for 13 years, he had a full opportunity of acquiring a unique knowledge of the international relations of the Church throughout the world. In 1903, when Cardinal Merry del Val succeeded Cardinal Rampolla as secretary of state, Mgr. della Chiesa was retained in his post. On Dec. 16 1907, Pius X. appointed him Archbishop of Bologna, and on May 25 1914 raised him to the dignity of cardinal. The outbreak of the World War in Aug. of that year, and the death of Pius X. a few weeks later, found him in the midst of the pastoral duties of his great diocese. At this time, as Cardinal-Archbishop of Bologna, he delivered a remarkable address on the attitude and duty of the Church during the war, and strongly emphasized the paramount importance of the Holy See observing strict neutrality, not of indifference, but of impartiality, while leaving nothing undone to restore peace and good-will and to mitigate suffering. The address caused a deep impression, and it was no doubt much in the minds of the cardinals when they assembled in conclave for the election of a new pope on the last day of Aug. 1914. On Sept. 3, after 10 scrutinies or votings, Cardinal della Chiesa was elected by a large

majority, and was proclaimed from the balcony of St. Peter’s as Benedict XV. He died Jan. 22 1922.

**BENNETT, CHARLES EDWIN** (1858–1921), American classical scholar (see 3.740), died May 5 1921 at Rhaca, N.Y. His later publications include *Syntax of Early Latin* (two vols., 1910, 1914); *New Latin Composition* (1912) and *Horace’s Odes and Epodes* (1914, in the Loeb Classical Library).

**BENNETT, [ENOCK] ARNOLD** (1867– ), English novelist and playwright, was born in the Potteries district, Staffs., May 27 1867. Educated at Newcastle-under-Lyme, he was intended for the law; but abandoned it in 1893 for journalism. He was assistant-editor and then editor of the periodical *Woman*, but in 1900 gave up journalism and became a prolific writer of books, especially novels illustrating the life of his native district, early examples of which were *Anna of the Fine Towns* (1902) and *The Grim Smile of the Fine Towns* (1907). In 1908 he established his reputation as a novelist with *The Old Wives’ Tale*, followed by the series *Clayhanger* (1910); *Hilda Lessways* (1911) and, much later, *The Roll Call* (1919). But he also ventured into other genres of fiction, sensational, humorous and ironical, of which *The Grand Babylon Hotel* (1902); *Sacred and Profane Love* (1905, dramatized 1919); *Buried Alive* (1908); *The Card* (1911); *The Regent* (1913); *The Lion’s Share* (1916) and *The Pretty Lady* (1918) are examples. His plays, especially *The Great Adventure* (dramatized in 1913 from the novel *Buried Alive*); *What the Public Wants* (1909); *The Honeymoon* (1917); *Milestones* (with Edward Knoblock, 1912) and *The Tilt* (1918) showed him a master of modern comedy; and he also produced in *Judith* (1910), a modernized version of the biblical story. In 1920 he published *Our Women*, a series of essays on modern feminine types and feminist problems.

**BENNETT, JAMES GORDON** (1841–1918), American newspaper proprietor (see 3.741), died May 14 1918, in Paris, whence he had long directed the policies of the *New York Herald*. In his will he provided for the establishment of “The James Gordon Bennett Memorial Home for New York Journalists” in memory of his father, the founder of the *New York Herald*.

**BENSON, ARTHUR CHRISTOPHER** (1862– ), English man of letters (see 3.745), was in 1915 elected master of Magdalene College, Cambridge. Among his recent books are *Ruskin: a Study in Personality* (1911) and biographies of his brother Hugh: *Memoirs of a Brother* (1915) and of his sister *Life and Letters of Maggie Benson* (1917), besides various volumes of essays and prose sketches.

His younger brother, EDWARD FREDERICK BENSON (1867– ), published after 1910 a large number of novels, amongst which may be mentioned *Thorley Weir* (1913); *Dodo the Second* (1914); *David Blaise* (1916); *Mr. Teddy* (1917); *The Countess of Lowndes Square* (1920). He also wrote a one-act comedy, *Dinner for Eight*, which was successfully produced at the Ambassadors’ theatre, London, in March 1915.

The youngest brother, ROBERT HUGH BENSON (1871–1914), died at Salford Oct. 10 1914. In 1911 he was appointed private chamberlain to Pope Pius X. His later books include *The Dawn of All* (1911), a curious forecast of England under Catholic government; *Come Rack! Come Ropel* (1912); *An Average Man* (1913) and *Initiation* (1914).

**BENSON, SIR FRANCIS ROBERT** (1858– ), English actor, (see 3.745), was knighted in 1916. During the World War he served for over two years as an orderly in a canteen managed by Lady Benson, first near Belfort and later at St. Just and near Senlis. In 1918 he was attached as an ambulance driver to various French regiments engaged in the Somme and Aisne campaign, and he received the Croix de Guerre on the battlefield near Oudenarde.

**BENSON, WILLIAM SHEPHERD** (1855– ), American naval officer, was born at Macon, Ga., Sept. 25 1855. He graduated from the U.S. Naval Academy in 1877, and after various promotions became captain in 1909 and rear-admiral in 1915. He had been commandant of the Philadelphia Navy Yard two years when, in 1915, he was appointed chief of naval

operations. He was a member of the commission appointed to confer with the Allied Powers in 1917, naval representative in drawing up terms of the Armistice, and naval adviser to the American Peace Commission. He was retired automatically in 1919 and made admiral for life.

**BENTLEY, JOHN FRANCIS** (1839-1902), English architect, was born at Doncaster in 1839, and commenced his career as an engineer, later passing three years in a builder's office, a course of practical training the benefits of which are evident throughout his work. He subsequently entered the office of Henry Clutton whose practice was very largely in an ecclesiastical direction, and where young Bentley's bias towards that French Gothic treatment of design, by which his earlier work was distinguished, found support and encouragement. Established on his own account in 1862, commissions flowed in for work not only of an architectural nature but also giving scope for his talent in designing for the subsidiary arts, such as stained glass, goldsmith's work, embroidery and the like. His earliest important undertaking was the enlargement and decorative treatment of St. Francis' church, Notting Hill, followed by other ecclesiastical work in London and the country, in which he shows an increasing tendency towards a more English form of expression in his design. The beautiful seminary of St. Thomas at Hammersmith, noteworthy not only for its architectural treatment but, as usual with Bentley, for a carefully conceived and thought-out plan, was followed by St. John's school at Beaumont, one of the best examples of his power to deal with design based on English Renaissance of the 17th century. For many years he was occupied in the completion of Carlton Towers, the seat of Lord Beaumont, left unfinished on the death of E. W. Pugin. On the decorative work of this fine building he spent during the 15 years he was engaged on it an immense amount of thought and invention, and with marked success. A very excellent example of Bentley's skill in adapting mediæval ideals to the circumstances of our times, while yet infusing them with an individuality that lifts them above the level of shoer copyism, is to be found in Holy Rood church, built by him 1892, in which, as regards the interior, he gave free rein to his sense of colour as a final complement of his design.

It was after 30 years of strenuous work at his art, and in his 65th year that Bentley—his claims strongly supported by the most eminent of his fellow architects—was appointed by Cardinal Vaughan as architect of the proposed Roman Catholic cathedral in Westminster, his unremitting and enthusiastic labour upon which occupied the remainder of his life. Already, before his selection by the authorities, it had been decided that for the new building it would be far from desirable to adopt Gothic principles and traditions. The principal factor in coming to this conclusion was the obvious danger of an unpleasant competition, both as regards size and aesthetic treatment, with the closely neighbouring Westminster Abbey. To equip himself thoroughly for dealing with the problem in terms of the Byzantine style settled upon, Bentley determined, as a preliminary, to study his subject at first hand in Italy and Constantinople, and in 1894 he spent several months in northern Italy and Rome with this end in view. From a series of sketch plans prepared on his return was gradually evolved that adopted for the cathedral as now built, a masterly treatment of a difficult problem. The exterior dimensions of the building are 360 ft. in length by 156 ft. in width, the interior of the nave being 232 ft. long, and 60 ft. wide. The three bays into which its length is divided are covered with saucer-shaped domes 112 ft. in height, and springing from enormous piers. The aisles, narrow, as being used for processional purposes only, give on to the seven side-chapels. The truly imposing character of the building was perhaps more to be appreciated when its walls, piers and arches were in their undecorated state, and full value was given to its 542 ft. of length, and to a vast nave higher and wider than any in England. It was always intended that the whole of the inside wall and arch surface should be clothed with marble and mosaic, and to no one could so sumptuous a manner of vesting his

building in rich apparel appeal more than to Bentley, and in no hands could it have been placed with more hope of success. There was, however, much difficulty in arriving at a scheme for the comprehensive treatment of the whole of the vast building, which should be devotional and symbolic, and above all possess a unity of conception. Bentley himself prepared a very thoughtful and complete proposal, partly embodied in the mosaics so far executed, but, unfortunately, only partly so.

In May 1898 he visited the United States to consult as to the proposed cathedral at Brooklyn, and for this he prepared a design, in which he, this time, reverted to Gothic, and which he left incomplete at his death. He died after seeing all but carried into effect and full realization his dream of a church building which should in a grand manner show forth all of the beauty and holiness of that religion to which he had as a young man given himself, and which was throughout his life, in all the work of his genius, his inspiration. On the eve of being presented with the gold medal of the Royal Institute of British Architects he died at Clapham March 2 1902.

See W. de l'Hôpital, *Westminster Cathedral and its Architect* (1920); T. J. Willson, "Memoir," *Journal of R.I.B.A.* (III. Series, vol. ix). (C. H. To.)

**BERCHTOLD VON UND ZU UNGARSCHITZ, LEOPOLD**, COUNT (1863- ), Austro-Hungarian statesman. The Berchtolds are a Moravian noble family whose patent of knighthood and nobility of the empire dates from 1616. They became counts in 1673, and acquired their Hungarian rights in 1751. Count Leopold Berchtold, born April 18 1863, was employed first in the Moravian Government, entered the service of the Austro-Hungarian Foreign Office in 1893, and in 1894 was attached to the Paris embassy. In 1903 he went as councillor of legation to St. Petersburg, and in Dec. 1906 was appointed ambassador there. With the Russian court and the aristocratic society of St. Petersburg he maintained the best relations, but failed entirely in his zealous efforts to accommodate the obviously increasing differences between Russian and Austro-Hungarian policy. He took a leading part in the negotiations preceding the crisis caused by the annexation of Bosnia-Herzegovina, which aimed at securing common action of the two powers in the Balkan question. It was at his château of Buchlau, in Moravia, that the fateful conference took place between Isvolski and Aehrenthal (Sept. 15 1908). At the time of the strained relations between the Cabinets of St. Petersburg and Vienna, which followed the annexation, and under the shadow of the personal feud between the two foreign ministers, the position of Berchtold at St. Petersburg was extremely difficult. For months together he had to avoid all official intercourse with the Russian Foreign Office; and it was not till the spring of 1909, when the violence of the quarrel had abated, that he could resume his efforts to improve the relations between the two states. His success was only temporary; the tension, indeed, for a time relaxed; but gradually it increased, and during the last months of his residence in St. Petersburg became extreme. In March 1911 Count Berchtold was recalled from Russia, and on Feb. 17 1912 he was, against his own will, appointed Aehrenthal's successor as Foreign Minister.

His efforts were primarily directed towards securing the position of Austria-Hungary in the Balkan Peninsula. He wished to bind Bulgaria more closely to the Triple Alliance; to strengthen the ties of the Habsburg Monarchy with Rumania and Turkey; to foil the aspirations of Serbia for an extension of territory. To the idea of solving the questions at issue with this latter power with the sword he was at this time opposed, contemplating a peaceful solution of the Balkan question by agreement with Russia and the Western Powers. In this sense he spoke at the first session of the Delegations in which he took part as Foreign Minister. But the increasingly obvious efforts of Russian statesmen to weaken the influence of Austria-Hungary in the Balkans, the aggressive activities of the Serbs, and the ambiguous behaviour of Bulgaria forced him to change his attitude, especially as he failed to receive from the Western



Powers the support which he had sought from them. In Oct. 1912, at a meeting at San Rossore, he came to certain agreements with the Italian Foreign Minister, San Giuliano, of which the objects were to secure the autonomy of Albania and to counter Serbia's plan for an extension of her power in the Adriatic coast-lands. The renewal of the Triple Alliance followed at the beginning of December.

Meanwhile the struggle between Turkey and the Christian nations of the Balkans had broken out. During the three Balkan wars, fought between Oct. 1912 and Aug. 1913, Berchtold's attitude was a weak one. He repeatedly took steps towards active intervention, but drew back when the Entente Powers used threats and the other members of the Triple Alliance intervened with counsels of moderation in Vienna. His efforts at the close of the third Balkan War to secure a revision of the Treaty of Bucharest (Aug. 10 1913), which was unfavourable to Bulgaria, were as unsuccessful as his attempt to secure an accommodation between Bulgaria and her rivals by way of direct negotiation. The prestige of Austria-Hungary in the Balkans noticeably declined. Serbia's endeavours to extend her power to the Adriatic, and to win recruits for the ideal of Great Serbia among the kindred Slav races of Austria-Hungary, became more and more evident and pressed for a decision. For these reasons, at the conferences at the Ballplatz which followed the murder of the heir to the throne, the Archduke Francis Ferdinand, on June 28 1914, Berchtold maintained the view that a definitive settlement with Serbia was essential, even at the risk of war with Russia and France. He does not seem at that time to have reckoned with the possibility of an active participation of Great Britain on the side of the opponents of the Triple Alliance.

After the outbreak of the World War he directed his efforts to inducing Italy and Rumania to carry out their obligations and to securing new allies for the Central Powers. These efforts were for the most part unsuccessful. Turkey alone joined the Central Powers. Rumania and Italy declared their neutrality; even Bulgaria dragged out the negotiations, though Berchtold offered great concessions in return for her active intervention on the side of Austria-Hungary and Germany. Italy's demands for compensation were indeed acknowledged in principle by Berchtold, under pressure from Germany, but he embarked on the negotiations with hesitation, and down to the day of his resignation he refused to listen to any proposal for the cession of territory which had long been under Austrian rule. In the course of the war Berchtold came into conflict with German statesmen and the German Supreme Army Command. He thought that Germany did not give sufficient support to her ally in the severe struggle against the superior strength of Russia, and protested strongly against the readiness with which Germany had agreed to the territorial and other demands of Rumania and Italy. The reasons of his fall, which took place on Jan. 13 1915, are still obscure, but it is certain that the attitude of Stephen Tisza and his adherents, from the autumn of 1914, in refusing to coöperate with him was a contributory cause. In March 1916 Berchtold was appointed *Obersthofmeister* (Lord High Steward) to the heir to the throne, Charles Francis Joseph, whom he subsequently served as *Oberkämmerer* (Lord High Chamberlain). After the fall of the dynasty he took no part in politics.

**BERENGER, RENÉ** (1830-1915), French lawyer and politician (see 3.769), died Aug. 29 1915.

**BERESFORD, CHARLES WILLIAM DE LA POER BERESFORD, 1ST BARON** (1846-1919), British admiral (see 3.770), who was raised to the peerage in 1916, died in London Sept. 6 1919.

**BERGSON, HENRI LOUIS** (1859- ), French philosopher, was born in Paris Oct. 18 1859. Educated at the Lycée Corot, and the École Normale he was successively professor of philosophy at the Lycée d'Angers 1881-3, at the Lycée de Clermont 1883-8, at the Collège Rollin 1888-9, at the Lycée Henry IV. 1889-97, at the École Normale Supérieure 1897-1900 and at the Collège de France 1900-21. In 1912 he was Gil-

ford lecturer at Edinburgh. Of the three works which constitute together the full exposition of his interpretation of experience, *Les Données Immédiates de la Conscience* was published in 1889, *Matière et Mémoire* in 1896, and *L'Évolution Créatrice* in 1907. The English translations (*Time and Free Will, Matter and Memory and Creative Evolution*) all belong to 1910-2. He had published also *La Rive* (1900). With the exception of a pamphlet, *La Signification de la Guerre* (1915), nothing more appeared until *L'Énergie Spirituelle* (1929), with Eng. trans. *Mind-Energy* (1920).

For a discussion of his work, see **PHILOSOPHY**.

**BERLIN** (see 3.785).—Since 1910 the city of Berlin (pop., Greater Berlin 1919 census, 2,902,509; 1910 census 2,071,257) has undergone a very considerable development in respect of the form of its municipal organization. The rapid growth of the suburbs, which were independent communities, necessitated the adoption of certain main lines of procedure, applicable both to them and to Berlin, in order to prevent conflicting action on the part of the authorities on one side and the other. This led, in 1912, to the creation of Greater Berlin as, in the first instance, an association of the city with the more important outlying districts for special objects. It embraced the city of Berlin and the towns of Charlottenburg, Schöneberg, Neukölln, Wilmersdorf, Lichtenberg and the administrative circles of Teltow and Niederbarnim. Its objects were to institute a common control of streets, roadways and the elevated railway; also of building and street alignment plans, the uniform co-ordination of police regulations and the acquisition of large tracts of forest and of land for building. This special union came into force on April 1 1912. It soon became manifest, however, that beyond coöperation for special purposes, a further co-ordination of the administrations of these places was requisite. It was only in the year 1920 that it was possible, after long negotiations, to form a new municipality of Berlin, embracing all the suburbs under a single united administration. A law to this effect was carried through the Prussian Constituent Assembly on April 27 1920 and was put into force on Oct. 1 of the same year. This law effected the centralisation of Berlin and all its suburbs into one uniform municipal region (*Stadtkreis*), but nevertheless left large powers of local self-administration to the individual communes (*Gemeinden*).

On May 15 1912 the former Secretary of State for the Treasury of the Empire, Wernuth, was elected chief burgomaster of Berlin in place of Kirschner, who had resigned. Under his administration, which lasted till Nov. 25 1920, the city experienced notable developments. The first municipal crematorium was opened in 1912. In June 1914 the ship canal uniting Berlin with Steftin was inaugurated. In the same year the city acquired the estate of Lanka, thus securing extremely valuable land for settlement purposes. In Oct. 1915 the city purchased the Berlin Electrical Works for 128 million marks (pre-war value about £6,400,000). The years of the war necessitated the vigorous intervention of the municipal administration in order to keep the population supplied with food and other necessities of life. A special commission for food supplies was appointed as early as 1914. In 1915 the supply of meat, vegetables, milk, etc., by the municipality was instituted. The management of all these supplies necessitated the appointment of a host of officials. The establishment of the War Departments of the empire and of Prussia as well as of the city thus entailed an accession of population which by 1917 had caused a great dearth of house accommodation, a scarcity which constantly increased up to 1921, so that special offices for enabling the public to obtain dwellings had to be established under municipal supervision. Even in 1921 it was almost impossible to find a flat. The general necessities arising out of the war demanded vast expenditure on the part of the city, so that its financial position had by 1921 become extremely unfavourable, while municipal taxation had been about trebled.

The city of Berlin suffered severely from the effects of the revolution of Nov. 9 1918. The revolution itself was practically bloodless, so far as Berlin was concerned, although the stormy sittings of the Workmen's and Soldiers' Councils, held in the Reichstag building, occasionally led to minor collisions. It was not till Christmas 1918 that serious fighting took place, when the Independent Socialist party, supported by the Sailors' Division, tried to seize power. After several days of sanguinary combats in the neighbourhood of the castle and the royal stables, where the sailors had established themselves, the division was ultimately compelled to surrender. Early in March 1919 the Spartacist insurrection broke out; it began in the suburb of Lichtenberg and spread over the whole

centre of the city. The number of those who were killed in the street fighting was 1,175. The last victims of the revolution met their death on Jan. 13 1920 when a mass of people incited by Spartacist propaganda in connexion with the parliamentary debates on the Industrial Councils bill (*Betriebsrätegesetz*), attempted to storm the Reichstag building. There were 42 killed and 105 wounded. The Kapp Putsch in March of the same year was likewise attended by some casualties, but the decisive episode was a general strike imposed by the Socialist parties and the working-class leaders in order to put an end to Kapp's usurpation of power.

As a result of the assimilation of the municipal to the parliamentary franchise a large Left majority composed of Social Democrats, Independent Socialists and Communists was elected to the Municipal Council of Greater Berlin. The Berlin school system was presently recast in the sense of the extreme secularists, a change which the non-Socialist parties were in 1921 still vigorously combating. The workmen employed by the municipality and the tramway men constantly demanded higher wages, which even the extreme Left majority in the Council were unable to concede, so that strikes in the electricity and gas works and cessation of work on the tramway lines were of frequent occurrence. Gradually, however, the economic life of Berlin seemed by 1921 to be entering upon a period of greater regularity. Chief Burgomaster Wermuth was succeeded in Nov. 1920 by the former city treasurer, Boss. (C. K. \*)

**BERNHARDI, FRIEDRICH VON** (1849- ), German military leader and writer, was born Nov. 22 1849 at St. Petersburg. He took part in the war of 1870-1 as a young officer in the 14th Hussars. When the German troops entered Paris in March 1871 he was the first German to ride into the city. From 1891 to 1894 he was German military attaché at Berne and was subsequently head of the military history department of the Grand General Staff in Berlin. He was appointed general in command of the VII. Army Corps at Münster in Westphalia in 1907, but retired two years later and busied himself as a military writer. Wide-spread attention was excited by the memoirs of his father, the diplomatist and historian, Theodor von Bernhardi, which he published, and still more by his celebrated book *Germany and the Next War* which appeared in 1912. On the outbreak of war in 1914 he was again placed at the head of an army corps and fought with success first on the Stochod, where he stormed the bridgehead of Tseretze and afterwards on the western front, in particular at Arras-Étapa.

**BERNHARDT, SARAH** [ROSINE BERNARD] (1845- ), French actress (see 3.801), made a specially successful tour in America in 1906. In 1909 she played Jeanne d'Arc in Paris. In 1910 she again toured in America. In 1913 she was given the Cross of the Legion of Honour. Though lame as the result of an operation, she appeared in Nov. 1920 in Paris in a new play *Daniel*, by Louis Verneuil, and repeated this in London in April 1921.

**BERNSTEIN, EDUARD** (1850- ), German Social-Democratic politician and writer, was born in Berlin Jan. 6 1850. From 1866 to 1878 he was employed in banks. Since 1872 he has been an active advocate and expounder of socialism. In 1878 he acted as private secretary to K. Höpfgberg, editor of the socialistic review *Zukunft*. From 1881 to 1890 he was on the editorial staff of the *Social-Democrat*, a leading organ of the German Social-Democratic party, which was published at Zürich because, owing to the anti-socialistic legislation, free expression for its views could not be found in Germany. He was expelled in 1888 and migrated to London, where he lived in intimate intercourse with Friedrich Engels and other followers of Karl Marx. He returned to Germany in 1901 and was elected deputy to the Reichstag for Breslau, a seat which he continued to hold till 1907. His numerous published works include: *Die Voraussetzungen des Sozialismus und die Aufgaben der Sozialdemokratie* (1899); *Die Kommunistischen und Demokratisch-Sozialistischen Strömungen in England während des 17ten Jahrhunderts* (1895); *Zur Geschichte und Theorie des Sozialismus* (1900); *Ferdinand Lassalle und seine Bedeutung für die Arbeiterklasse* (1904); *Sozialismus und Demokratie in der grossen Englischen Revolution* (1908) and an edition of Lassalle's speeches and writings with a biographical introduction (3 vols., 1893-5), etc. In these he dealt principally with the theoretical and historical aspects of socialism. In 1904-5 he

edited the monthly publication *Dokumente des Sozialismus* and in 1904 the weekly *Das Neue Montagblatt*. In the conflict between the orthodox Marxists and the revisionists Bernstein was one of the foremost champions of the latter. His differences with Kautsky, the literary protagonist of the strictest sect of the Marxians, were gradually healed after Bernstein, like Kautsky, associated himself with the Independent Socialists in 1915, and still more when both of them broke with the extreme Independents, the self-styled Communists, who advocated government by councils on the Moscow pattern and the "dictatorship of the proletariat." Immediately after the revolution Bernstein was appointed Secretary of State for the Treasury, an office which he held till Jan. 1919. He had again been a member of the Reichstag from 1912-8. Subsequently he left the Independents and returned to the fold of the governmental German Social-Democratic party.

**BERNSTORFF, COUNT JOHANN HEINRICH VON** (1862- ), German diplomatist and politician, was born in London Nov. 24 1862, the son of the Prussian diplomatist Count Albrecht von Bernstorff. He entered the diplomatic service in 1899, was secretary of legation successively at Belgrade, Dresden, St. Petersburg and Munich, and (1902-6) councillor of embassy in London. He then went as consul-general to Cairo, whence he proceeded as German ambassador in 1909 to Washington and remained there until America's declaration of war against Germany in April 1917. He made great efforts to facilitate mediation by President Wilson, but he did not receive the support he expected from authoritative quarters in Berlin. He himself has repudiated any active connection with the criminal plots and intrigues which were conducted by German agents, including the German military attaché, Boy-Ed, in America before the rupture of relations; he also maintains that he entirely disapproved of the German foreign secretary, Zimmermann's, monstrous proposals to Mexico. If so his position must have been an exceedingly difficult and anomalous one. On the American declaration of war he returned to Germany and was sent as ambassador to Constantinople, where he was employed until 1918. In various publications he has endeavoured to prove that Germany, if she had followed the proper policy, could have avoided war with America. This statement of his views excited much controversy in his own country. When the revolution broke out Bernstorff left the diplomatic service, but has since taken an active part in parliamentary politics as a member of the Democratic party in the Reichstag, and has also maintained a close connexion with the international press and with pacific post-war propaganda. (C. K. \*)

**BERTHELOT, HENRI MATHIAS** (1861- ), French general, a son of the chemist, Marcellin P. E. Berthelot (see 3.811), was born at Feurs (Loire), Dec. 7 1861. At 20 years of age he entered St. Cyr, and in 1883 was appointed a sub-lieutenant in the 1st Regt. of Zouaves. Three years later he was promoted lieutenant. In Nov. 1891 he was made a captain and was transferred to the 99th Inf. Regiment. In 1907 he became a lieutenant-colonel and was posted to the 57th Inf. Regiment. He was then given a staff appointment, being promoted colonel in June 1911. In Dec. 1913 he was made a general of brigade. On the outbreak of the World War he was appointed head of the French operations staff at headquarters, and in this capacity he exercised a very marked influence on the course of events in Aug. 1914, so much so as to expose him later to the reproach of having been "the irresponsible commander-in-chief" during the disastrous battle of the Frontiers. In Nov. of the same year he was given command of a division. In Aug. 1915 he became commander of the XXXII. Army Corps, an appointment which he retained until Sept. 1916; when he was made chief of the French military mission to Rumania. Here his thoroughness was the principal factor in revising the Rumanian army, and the fruits of his work appeared in the campaign of 1917. In June 1917 he was made a grand officer of the Legion of Honour. After a brief mission to the United States he was, in July 1918, given command of the V. Army. This army he commanded in the battles on the Marne

and the Alsace, which initiated the final Allied offensives. Later, he was sent on a mission to the Balkans. In Oct. 1919 he was made governor of Metz.

**BERTHELOT, PHILIPPE JOSEPH LOUIS** (1866— ), French diplomat, was born Oct. 9 1866, a son of Marcellin Berthelot, the famous chemist and politician (see 3.811). After having passed through the regular stages of a diplomatic career, he was sent on a mission to the Far East in 1902, and returned to the Foreign Office to mount the hierarchical steps of promotion, many of which, by reason of his appointment as *chef de cabinet*, he was able to take at a single bound. He acted as Briand's righthand man throughout his term of office as Minister of Foreign Affairs and prime minister; became Clemenceau's trusted adviser during the World War and the Peace Conference, and succeeded Jules Cambon, with the rank of an ambassador, as general secretary of the Ministry of Foreign Affairs.

**BERTIE, FRANCIS LEVISON BERTIE**, 1st Viscount (1844-1919), English diplomatist, was born at Wytham Abbey, Oxon., Aug. 17 1844, the second son of the 6th Earl of Abingdon. He was educated at Eton, and in 1863 entered the Foreign Office. In 1874 he married the daughter of the 1st Earl Cowley. He was attached to the special embassy to Berlin in 1878, and in 1881 was secretary to the Duke of Fife's mission to invest the King of Saxony with the Garter. In 1894 he became assistant Under-Secretary for Foreign Affairs, a post which he retained till 1903. He was then appointed British ambassador to Italy, but remained in Rome for only a year, being appointed in 1905 ambassador to France. The Anglo-French agreement had been signed in 1904, and the new ambassador's personal popularity was most successful in strengthening the ties thus formed between England and France. On the outbreak of war in 1914 Sir Francis Bertie's position became one of great importance and responsibility, and he was untiring in his efforts towards establishing the most complete understanding between England and France. He retired in 1918. Bertie had been made K.C.B. in 1902, G.C.V.O. and privy councillor in 1903, G.C.M.G. in 1904, and G.C.B. in 1908. He was raised to the peerage on his retirement with the title of Viscount Bertie of Thama. He died in London Sept. 27 1919 and was succeeded by his son, Vere Frederick Bertie (b. 1878).

**BERTILLOM, ALPHONSE** (1853-1914), French anthropometrist (see 3.812), died in Paris Feb. 13 1914.

**BERTOLINI, PIETRO** (1853-1920), Italian statesman, was born at Montebelluna in 1853. He began his career as a barrister and student of economic and administrative questions, and entered parliament in 1891 as member for his native town. Two years later he became Under-Secretary for Finance in the Crispi Cabinet. He was afterwards Under-Secretary at the Ministry of the Interior in the Pelloux Cabinet (1898-1900), in which he was, so to speak, the representative of Baron Sonnino's party. On the fall of Gen. Pelloux he hoped to return to office in a future Sonnino ministry; but as the latter seemed ever less likely to become a reality, Bertolini lost patience and joined Sig. Giolitti. His conduct in abandoning his old chief was much criticised at the time, but his new patron chose him as Minister of Public Works in the Cabinet of 1907. He proved a capable administrator, but his qualities were taxed to the utmost by the terrible earthquake at Messina and Reggio in 1908. When Giolitti returned to power in 1911 he did not at first offer an appointment to Bertolini, but in the autumn of 1912 he entrusted him with the newly constituted Ministry of the Colonies. He failed, however, to show any exceptional qualifications for that position, and did little more than introduce some of the less desirable features of the Italian bureaucratic system into the new African possessions; the continued resistance of the Arabs in Libya was generally regarded as largely due to Bertolini's administrative errors. He was *rapporteur* for the extended suffrage bill, which first came into force with the general elections of 1913; the measure had been introduced to please the demagogic spirit which Giolitti wished to conciliate, but Bertolini must be given credit for the ingeniousness of the machinery which he devised for enabling illiterates to vote and for

avoiding electoral corruption as far as possible. On the outbreak of the World War Bertolini, as a faithful Giolittian, was an uncompromising neutralist, and came in for much obloquy in consequence. Throughout the war he remained in retirement, and failed to be re-elected in 1919. Sig. Nitti appointed him senator and president of the Italian delegation on the Reparations Commission. He was the author of several valuable works on political and economic questions, notably a volume on local government in England. He died at Turin, Nov. 28 1920.

**BESANT, ANNIE** (1847— ), English theosophist, was born in London Oct. 1 1847, the daughter of William Page Wood. She married in 1867 the Rev. Frank Besant (d. 1917), afterwards vicar of Sibsey, Lincs., but obtained a separation from her husband in 1873. She had become an ardent free-thinker, and shortly afterwards she was prosecuted and convicted, together with Charles Bradlaugh (see 4.372), for publishing "blasphemous" literature. From 1874 to 1888 she worked in close association with Bradlaugh both in politics and in free-thought propaganda, as a lecturer and a writer of pamphlets over the signature of "Ajax." Her increasing tendency towards socialism of the more revolutionary type occasioned a divergence between them after 1885, which was completed in 1889 by her adhesion to the Theosophical Society. She became a devoted pupil of Mme. Blavatsky (see 4.428), founded schools at Benares, and was elected president of the Theosophical Society in 1907. In later years her activities again assumed a political cast. She founded the Indian Home Rule League and became its president in 1916, and in 1917 she was president of the Indian National Congress. In addition to her numerous free-thought pamphlets and a large number of later works on theosophy, she published her *Autobiography* in 1893, *The Religious Problem in India* (1902) and other books.

**BESLER, HANS VON** (1850-1921), Prussian general and governor of Poland during the German occupation, was born April 27 1850 at Greifswald. He was one of those generals who, after having been placed upon the retired list, were recalled in 1914 to assume important commands. He conducted the siege of Antwerp, which he occupied on Oct. 9 1914. In 1915 he was employed on the eastern front, and on Aug. 19 of that year took Novogeorgievsk. From Aug. 27 1915 to Nov. 1918 he was German governor-general of Poland at Warsaw, in which capacity he endeavoured with diminishing success to organise a form of Polish national government and representation under German auspices, as also to form a Polish army under German control. The Armistice and the German Revolution put an end to the complicated attempts of Beseler and the Austrians to arrive at a *modus vivendi* with regard to Poland's political and territorial destiny. The revolutionary Soldiers' Councils asserted themselves, and the governor-general with the German troops of occupation left the country. He died near Potsdam Dec. 22 1921.

**BESNARD, PAUL ALBERT** (1849— ), French painter, was born in Paris in 1849 and studied at the Ecole des Beaux-Arts, winning the Prix de Rome in 1874. Until about 1880 he followed the academic tradition, but then broke away completely, and devoted himself to the study of colour and light as conceived by the impressionists. The naturalism of this group never appealed to his imagination, but he applied their technical method adapted to meet more complicated problems of light, such as a union of twilight and artificial light to ideological and decorative works on a large scale towards which his residence in Rome had strongly inclined him. Such are his decorations at the Sorbonne, the Ecole de Pharmacie, the Salle des Sciences at the Hôtel de Ville, the mairie of the first arrondissement, the Théâtre Français, the Petit Palais, and the chapel of Besck hospital, for which he painted twelve "Stations of the Cross." A large panel, "Peace by Arbitration," was completed seven days before the outbreak of war in 1914. A great virtuoso, he has handled with equal facility water-colour, pastel, oil-painting and etching. Partly under the influence of Gainsborough and Reynolds, whom he studied during a three-years stay in England, he has applied his methods to a brilliant series of portraits, especially of women. Notable among these are the "Portraits

de Théâtre" (Mme. Réjane), and "Mme. Roger Jourdain." Recent work includes "Cardinal Mercier" (1917) and "The King and Queen of Belgium" (1919). His analysis and treatment of light is well seen in "La Femme qui se chauffe" in the Luxembourg, Paris, one of a large group of nude studies of which a recent example is "Une Nymphé au bord de la mer"; and in the work produced during and after a visit to India in 1911. His landscape work is represented by "L'île heureuse," and "Un Ruissseau dans la Montagne" (1909). A symbolist in his decorative work, Bessard's frank delight in the external world and his "chic" luminous technique bring him close to the 18th-century French painters. A foundation member of the Société Nationale des Beaux-Arts in 1890, in 1913 he became a member of the Institute and commander of the Legion of Honour. He has succeeded Carolus Duran as director of the French Academy in Rome.

See also C. Musclair, *Paul Albert Bessard* (1914); G. Moutrey, *Albert Bessard* (1916). (W. G. C.)

**BETHAM-EDWARDS, MATILDA** (1836-1919), British author, was born at Westerfield, Ipswich, March 4 1836. She studied French and German abroad and after some school-teaching in London, she settled down with her sister in Suffolk to manage the farm which had belonged to her father. Not content, however, with purely rural occupations, she contributed from time to time to *Household Words*, having the advantage at this time of the friendship of Charles Dickens and an early association with Charles and Mary Lamb, friends of her mother. On her sister's death she moved to London and wrote a number of novels of French life based on her frequent visits to France and her intimate knowledge of provincial French homes. In this way she did much to promote a better understanding between the two peoples. Her chief books are: *The White House by the Sea* (1857); *Anglo-French Reminiscences* (1898); *East of Paris* (1902); *Home Life in France* (1905); *Literary Rambles in France* (1907) and the posthumously published *Mid-Victorian Memories* (1919), which contains a personal sketch of its author by Sarah Grand. She died at Hastings Jan. 4 1919.

**BETHMANN HOLLWEG, THEOBALD VON** (1856-1921), Chancellor of the German Empire from July 1909 to July 1917, was born Nov. 29 1856 at Hohenfinow, the family property near Berlin, where he also died. He was descended from the Frankfurt banking family of Bethmann, which attained great prosperity in the 18th century, and a branch of which was founded by his great-grandfather Johann Jakob Hollweg, who had married a daughter of the house. The Chancellor's grandfather was Moritz August von Bethmann Hollweg, a Bonn professor of law, who was a leading member of the Prussian Diet from 1849 to 1855 and was Minister of Education under the Prince-Regent (afterwards William I.) from 1858 to 1862. It was to the Liberal and West-German as well as the commercial traditions of his family that Theobald von Bethmann Hollweg probably owed his appointment to the chancellorship in 1909 in a time of domestic and financial crisis. He had at the same time the qualification of a specifically Prussian career, having risen through the regular legal and official stages of promotion as Referendar, Assessor, Landrat, Government-President at Bromberg and Chief President of the province of Brandenburg. In 1905 he was appointed Prussian Minister of the Interior and in 1907 Secretary of State for the Imperial Home Office and Vice-president of the Prussian Ministry. At the time of Bethmann Hollweg's appointment to the chancellorship internal affairs, under his predecessor Prince Bülow, had reached a deadlock in the Reichstag owing to the revolt of a section of the Liberal-Conservative bloc against the proposal to establish death duties as part of the reform of the finances of the empire. The Catholic Centre, which had left the former parliamentary coalition before the dissolution of the Reichstag by Prince Bülow in 1907, was once more in alliance with the Conservatives, and the fiscal policy which these two parties had imposed upon the Government and the country had alienated the commercial classes and led to violent political conflicts. It was not until the general elections of 1912 had transformed the situa-

tion by bringing a great accession to the strength of the moderate National Liberals and the Left, especially the Social Democrats, that the Government was able to reckon upon a more amenable majority. In the interval Bethmann Hollweg endeavoured to conciliate the Catholic Centre by a policy of compromise in matters which had threatened to lead to a renewal of the *Kulturkampf*, such as the denunciation of the Reformation in the Papal Encyclical of 1910 and the Catholic demand for the modification of the Jesuit law. He secured the final abrogation of this law under stress of war conditions in April 1917. Bethmann Hollweg was likewise the sponsor of the new constitution for Alsace-Lorraine, which in 1911 established the government of that territory of the empire upon the basis of popular representation in a territorial assembly and admission, though without full state rights, to the Federal Council. He was less successful with the vexed question of the Prussian franchise, which in 1910 he attempted to solve by proposing a direct system of election while retaining in a modified form the local division of the electorate according to income-tax assessment into three classes. His bill was ultimately rejected by the reactionary Chamber of Deputies. This question was again to occupy him amid the stress of the war. Under the impression produced by the Russian Revolution of March 1917 he was constrained to inspire the "Easter message" of the Emperor as King of Prussia promising the abolition of the three-class system after the war, a proclamation which was followed in the same year by the edict of July 11 announcing that a bill would at once be introduced to enact equal direct and secret suffrage. This project of reform came too late to reconcile the revolutionary elements in the Prussian state. Bethmann Hollweg's political career ended immediately after the July edict, and, although a bill was introduced in the following Nov. by his successor, Count Hertling, the opposition of the Prussian Conservatives and other reactionary elements prevented it from passing before the revolution. He was equally unsuccessful in dealing with an outbreak of militarism in Nov. 1913 at Zabern in Alsace, where the population, exasperated by the truculence of a young officer, was subjected to the arbitrary exercise of martial law by the colonel in command of the garrison. Bethmann Hollweg's treatment of the incident satisfied neither the reactionaries nor the advanced parties, and, for the first time in the history of the Reichstag, a vote of censure was passed upon the Chancellor.

The foreign policy of Bethmann Hollweg was characterized by the indecision and half-heartedness which compromised his action in home politics. He shared the ambition of the Emperor and of the vast majority of his countrymen to set Germany at the head of Europe and to establish her influence throughout the world by the predominance of her commerce and industry and by the ubiquitous activity of her diplomacy supported by her preponderating military strength. In his speeches during the war the declaration "we must secure from the military and the political and also from the economic point of view the possibility of our expansion" is characteristic and recurs in various forms. In this sense he could truly have said "We could have got all we wanted without war," i.e. by establishing Germany's power in Europe, on the seas and beyond them in a way that would make her unassailable whatever her policy and action might be. What he could not realize was that the creation and maintenance of vast armaments, combined with the aggressive behaviour of those actions of German opinion which always asserted their influence in public affairs and the truculent tone of the Emperor's frequent public utterances, compelled Germany's neighbours, including Great Britain, to concert measures for meeting the imminent eventuality of active German and Austro-Hungarian aggression. He maintained, like many of his countrymen, that the Triple Entente was the arbitrary and artificial creation of the personal policy of King Edward VII., acting in accord with the feelings of commercial and political jealousy with which Germany's successes were thought to have inspired the British people. He himself, however, had much to endure before and during the war from the intrigues of the

military party, in particular from the hostility of the creator of the German navy, Admiral von Tirpitz, who was once and again put forward by the more aggressive chauvinists as their candidate for the chancellorship. But Bethmann Hollweg himself did not see that the influence of that powerful section of German opinion and its action in military and naval as in foreign policy furnished ample justification for such measures of precaution as the Western Powers and Russia concerted, measures which, indeed, proved hardly adequate to confront the first German onset in 1914.

The renewed conflict with France over Morocco in 1911, the dispatch of the gunboat "Panther" to Agadir, the consequent friction with Great Britain and the prolonged negotiations which led to the mutually unsatisfactory Franco-German Morocco agreement, mainly fell within the province of Bethmann Hollweg's able subordinate, Herr von Kiderlen-Waechter, who at that time was Secretary of State at the Foreign Office. Here, as on other occasions, the Chancellor was probably pacific in his intentions, but in the means which were adopted to secure Germany's objects he showed either lack of judgment or inability to control his political and military subordinates.

In his book *Betrachtungen zum Weltkrieg* (*Reflections on the World War*), written in his retirement at Hohenfinow after the collapse of Germany, he gives an account of the exchange of views which took place between him and Lord Haldane during the latter's visit to Berlin in Feb. 1912. This account ought to be read in conjunction with Lord Haldane's own report of his visit,<sup>1</sup> particularly with regard to the attempt of the two statesmen to find a formula for a treaty of mutual assurance calculated to allay apprehensions of war between Great Britain and Germany. Bethmann Hollweg wished to obtain an engagement from Great Britain to observe a benevolent neutrality in the event of Germany's becoming "entangled in a war with one or more other Powers," or, as he finally formulated it, "if war should be forced upon Germany." His conception of a war "forced upon Germany" was subsequently revealed by his defence of Germany's declarations of war upon Russia and France, accusing the one Power of having rendered war unavoidable by its precautionary measures of mobilization and the other of having opened hostilities by air raids which never took place. In the exchange of views regarding the German and British naval programmes Lord Haldane received the impression that Bethmann Hollweg was pursuing a different policy from that of Admiral Tirpitz, but that the latter had the support of a powerful and certainly active party in the country and was able to get his way. Indeed, Bethmann Hollweg himself says in his book that "when differences arose between the Admiralty and the civilian leadership public opinion was almost without exception on the side of the Admiralty." There were from time to time evidences of a similar lack of continuous agreement and coördination between the policy of the Chancellor and that of the Secretaries of State in other departments, while the views of the Emperor William II. himself were notoriously liable to sudden and incalculable change. In a marginal note on one of the diplomatic documents of July 1914, the Emperor contemptuously referred to Bethmann Hollweg as the "civilian Chancellor," as if policy were the business of the generals. Yet the Chancellor was in evident agreement with the Emperor's view that it was legitimate for Austria, backed by Germany, to alter the balance of power in the Balkans and to put an end to the traditional and national Russian policy of protecting the small Slav nations. Germany's "expansion" in the Near East was similarly to be promoted and her supremacy at Constantinople established at the expense of Russia's interests in a sphere that was vital for the Russian Empire.

The interview between the British ambassador, Sir Edward Goschen, and the German Chancellor, at their parting immediately before the declaration of war in 1914, when the latter in the course of "a harangue which lasted for about 20 minutes" spoke of the international treaty guaranteeing Belgium's neutrality as a "scrap of paper" and asked whether the British

<sup>1</sup> See *Before the War*, by Visct. Haldane (1920).

Government had considered "at what price that compact would have been kept," furnishes the crowning evidence of Bethmann Hollweg's essentially Prussian conceptions of political morality. "In the moment of anger the true man stood revealed. . . . To break a treaty pledging the national honour seemed a natural thing to him, if to keep it involved sacrifice and danger. . . . Herr von Bethmann Hollweg evidently thought that a plighted promise need not be kept, if the engagement involves momentous and unpleasant consequences. Not only does it throw the most unpleasant light upon his own notions of honour, but it makes the commentator ask whether it was possible to make any permanent settlement with a nation whose leading statesman obviously held the view that any treaty was only to be kept so long as it was profitable to the signatory parties."<sup>2</sup>

There is evidence that at the time when Germany broke the peace Bethmann Hollweg was in a state of extreme nervous tension, due probably as much to the sense of the moral quicksands on which Germany's case was based as to the collapse of all his calculations regarding the effect of his policy upon the other Great Powers. In the case of Great Britain his disillusionment was complete and confessed. In the case of Russia he had apparently hoped that a display of firmness would bring about the same public renunciation of Russian policy which Germany had been able to secure by the "bluff" of 1908-9 in connexion with the Austrian annexation of Bosnia and Herzegovina. The Austro-Hungarian ambassador Count Szögyenyi's report of his interview with William II. on July 5 is to the effect that in the event of action against Serbia the Emperor Francis Joseph could rely upon Germany's support and "he had not the slightest doubt that Bethmann Hollweg would entirely agree with this view. . . . Russia's attitude would be hostile, but William II. had for years been prepared for this war, and, should it ever come to war between Austria and Russia, we could be convinced that Germany with her customary loyalty to the Alliance would stand at our side." In subsequent conversation with Bethmann Hollweg Count Szögyenyi "ascertained that the Imperial Chancellor, just like the Emperor William, regards immediate action against Serbia as the most radical and best solution of our difficulties in the Balkans. From the international standpoint he considers the present moment more favourable than later and agrees that we shall inform neither Rumania nor Italy [both allies] beforehand of our eventual action."

Admiral von Tirpitz<sup>3</sup> testifies that upon his mind the ultimatum to Russia and the declaration of war produced the impression of being ill-considered and due to a want of management. "Bethmann Hollweg was throughout those days so excited and irritable that it was impossible to converse with him. I can still hear him as with uplifted arms he repeatedly emphasized the absolute necessity of the declaration of war and put an end to all further discussion." He told Tirpitz that war must be declared because the Germans wished to send patrols across the frontier at once. Moltke, on the other hand, informed Tirpitz that there was no such intention and that "from his point of view a declaration of war was of no importance."<sup>4</sup>

During the war period of Bethmann Hollweg's chancellorship (Aug. 1914-July 1917) his public speeches were designed to create the impression of Germany's invincibility. He was accused by his political adversaries of having all the time entertained the secret hope of coming to a separate understanding with Great Britain and of having influenced military and naval policy through the Emperor with this object in view. In reality he never approximated to the elementary conditions of peace terms with the Allies, and in respect both of Belgium and France constantly referred to guarantees in the shape of an extension of power (*Machtgrundlagen*) which would be a necessary condition of a settlement. "History," he said, "knows no instance of the *status quo ante* after such tremendous events"

<sup>2</sup> *The Outbreak of the War of 1914-1918*, C. Oman.

<sup>3</sup> Tirpitz, *Erinnerungen*, pp. 240-1.

<sup>4</sup> *Ibidem*.

(speech of April 5 1916). On the question of unrestricted submarine warfare he ultimately divested himself of responsibility, having declared to the Emperor in Jan. 1917: "I can give Your Majesty neither my assent to the unrestricted U-boat warfare nor my refusal. I submit to Your Majesty's decision" which was that of the General Staff and the Admiralty. He must have given his explicit assent to the monstrous note addressed on Jan. 19 1917 by his Secretary of State for Foreign Affairs, Zimmermann, to Mexico inviting her to attack the United States in the hope of annexing New Mexico, Texas and Arizona and to try to detach Japan from the Allied cause. His alleged high principles did not prevent him from associating himself with this scheme for a treacherous assault upon a Power with whom Germany was then at peace.

By the middle of July 1917 Bethmann Hollweg had lost all support in the Reichstag. The Conservatives and National Liberals were alienated by his Prussian franchise policy and his conflicts with the higher command. The Left and the Catholic Centre in which Erberger with his so-called Peace Resolution (adopted by the Reichstag on July 19) had acquired the upper hand were convinced that the Allied and Associated Powers would place no confidence in the overtures of men with the past of Bethmann Hollweg and Zimmermann. Finally, on the morrow of the publication of the second Prussian Franchise Edict, on July 14 1917, Hindenburg and Ludendorff came to Berlin in order to hold conferences with the chiefs of political parties regarding the terms of the "Peace Resolution." The Chancellor could not tolerate this military interference with his own department, and the Emperor, confronted with an ultimatum from his two indispensable military leaders, accepted the Chancellor's resignation. Bethmann Hollweg retired to Hohenfinow and took no further part in politics beyond writing his *Reflections on the World War* (vol. i. 1919). He died, at Hohenfinow on Jan. 1 1921, after a brief illness. (G. S.)

**BEYERS, CHRISTIAN FREDERICK** (1869-1914), S. African general, was born in Cape Colony in 1869 and went as a young man to the Transvaal, where he took a prominent part on the Boer side in the S. African War, winning high distinction in the field and bearing the rank of general when peace was made in 1902. Gen. Beyers had much influence, as soldier and statesman, among the Dutch-speaking people of S. Africa, and was, with Gen. Botha and Gen. Smuts, though in a less degree than they, one of the recognized leaders of the Transvaal Dutch. When responsible government was granted to the Transvaal, Beyers became speaker of the Lower House. He showed in the speaker's chair remarkable gifts. He was acute, tolerant and rigidly impartial, thus making a deep impression upon English-speaking S. Africans, who would have supported his claims to be the first speaker of the first S. African House of Assembly, had they been pressed by Gen. Botha, the first Prime Minister. Instead, Beyers was made commandant-general of the Citizen Forces of S. Africa, and in that capacity paid a visit to Great Britain, Germany, Switzerland and Holland in 1912. A man of fine physique, of passionate nature, and of profound religious convictions, Beyers, as commandant-general of S. Africa, was entertained with marked attentions during his visit to Germany by the Kaiser. When the World War broke out, he set himself in almost open opposition to the policy of the Botha Government. For some months this opposition smouldered. Then, at a moment when the S. African expeditionary force was being mobilized for the invasion of German S.W. Africa, and when rebellion was already smouldering among the irreconcilables of the S. African Dutch, Beyers resigned his post as commandant-general in a letter addressed to Gen. Smuts, then Minister of Defence, and published in *Het Volk*, an anti-Government journal. In this letter he declared that he had always disapproved the Government's intention to invade German S.W. Africa and that this disapproval was shared by the great majority of the Dutch-speaking people of the Union. Gen. Smuts replied in a stern letter declaring that the war was a test of the loyalty to their pledged word of the Dutch-speaking people, and accepting Beyers' resignation. A

<sup>1</sup> Scheidemann, *Der Zusammenbruch*, p. 74.

few weeks later Beyers took the field as a leader of the rebellion against the Government, only to be overwhelmed by the Government troops under the command of Gen. Botha, to be driven from pillar to post as a fugitive, and to be drowned on Dec. 7 1914 while trying to escape from his pursuers by crossing the Vaal river. His body was recovered two days later, and with his death the rebellion was brought to an ignominious end.

**BHOWNAGREE, SIR MANCHERJEE MERWANJEE** (1851- ), Indian parliamentarian, the son of a Parsee merchant of Bombay, was born in Bombay Aug. 15 1851, and began life as a journalist, but when only 22 was appointed, on the death of his father, to succeed to the Bombay agency of the Kathiawar state of Bhavnagar. Called to the bar at Lincoln's Inn in 1885, in the following year the Maharaja appointed him judicial councillor, a post in which he introduced far-reaching reforms. Settling in England in 1891, he actively associated himself with public bodies connected with India. He was the head of the Parsee organization in Europe and chairman of the Indian Social Club. To the Imperial Institute building he contributed, in memory of his only sister, the eastern colonnade leading to the Indian section. His compatriot Dadabhai Naoroji was in the 1892-5 parliament, but Bhownagree, elected in the latter year in the Unionist interest for N.E. Bethnal Green, was the only other Indian to enter the House of Commons, and the only one to be re-elected (1900). During his ten years there he impressed the House by the vigour and eloquence of his speeches on Indian matters, and he originated and unflinchingly maintained in and out of the House the long battle against the disabilities of Indians in South Africa and other overseas dominions of the Crown. His cogent and detailed statement of the case for Indians in the Transvaal after annexation was the basis of a blue-book (Cd. 2239, 1904), and was sent to Lord Milner by the Colonial Secretary, Alfred Lyttelton, with the observation that he felt much sympathy for the views expressed, and that it would be difficult to give a fully satisfactory answer. The practical result was that the proposals of the High Commissioner were in some important particulars rejected. Bhownagree was one of the first Indians to press forward the need for technical and vocational education in India side by side with the literary instruction which was too exclusively maintained. He was made a C.I.E. in 1886 and K.C.I.E. in 1897. In early life he wrote a history of the constitution of the East India Company, and made a Gujarati translation of Queen Victoria's *Life in the Highlands*. During the World War he assisted in repelling German falsehoods regarding British rule in India by means of a widely circulated booklet entitled *The Verdict of India*.

**BIGELOW, JOHN** (1817-1911), American diplomat and journalist (see 3.922), died in New York Dec. 19 1911. In 1909 he published three volumes of *Retrospections of an Active Life*, covering his career to 1866. Two additional volumes, ending with 1879, were issued by his son (1913).

**BIKANER, SIR GANGA SINGH, MAHARAJA OF** (1880- ), Indian soldier and statesman, was born Oct. 3 1880, and succeeded by adoption his elder brother, Dunga Singh, in 1887 as 21st ruler of the state. After education at the Mayo College, Ajmere, he was invested with full powers in 1898, and promptly showed energy and skill in their use in combating the great famine of 1899-1900. In the Chinese campaign of 1901 he accompanied the British contingent in command of his famous Camel Corps, the Ganga Risala, which also did good service in Somaliland in 1903. The first of his many visits to England was made in 1902, when he attended King Edward's coronation, and was made A.D.C. to the Prince of Wales, an appointment continued by King George when he came to the throne. In the World War the Maharaja offered the whole resources of the state and served first on the headquarters staff of the Meerut division in France, and later on the staff of the British commander-in-chief. In 1915, at the head of his Camel Corps, he took part in the fighting to withstand the Turkish invasion of Egypt. In 1917 he and Sir S. P. (afterwards Lord) Sinha were the first Indians to be called to London for Empire gatherings. They were members of the Imperial War Confer-



ence and assisted the Secretary for India at the Imperial War Cabinet. The Maharaja's public speeches attracted marked attention, and were collected under the title of *India's Imperial Partnership*. His warm sympathy with Indian aspirations of self-government within the Empire made the greater impression on public opinion because of the notable moral and material progressiveness and efficiency of his administration in Bikaner, and his constitutional reforms. He was selected to represent the Indian states at the Peace Conference and the Imperial Cabinet meetings in connexion therewith, and at Versailles on June 28 1919 he affixed the first Indian signature to a great international treaty. Keenly concerned to uphold the rights and dignities of the ruling princes, he formulated their views with force and skill, and his was the dominant personal influence in securing the constitution, under royal proclamation, of the Chamber of Princes in 1921 as a deliberative, consultative and advisory body. His appointment as chancellor, carrying the presidency of the small standing committee, was indicative of the intellectual ascendancy he had acquired in the deliberations of the rulers. He had made himself well known as a sportsman, and in 1920 the "record" tigris (9 ft. 7 in.) fell to his gun. A major-general of the British army, his honours included the grand crosses of the Victorian and the two Indian Orders, the knighthood of the Bath, the honorary doctorate in laws of Oxford, Cambridge and Edinburgh and the freedom of London, Edinburgh, Manchester and Bristol. His permanent local salute was raised from 17 to 19 guns. (F. H. Br.)

**BILHARZIOSIS** (see 3.932).—The complete elucidation of the cause, mode of transmission, prevention and cure of this disease (*Schistosoma haematobium*) was one of the triumphs of medical progress during the decade 1910-20. In 1913-4, in his annual report on Egypt, Lord Kitchener said: "It is high time that some steps should be taken to prevent the continuity of infection which has been going on so long in this country." At that time Egypt was a hot-bed of the disease, and so were many areas of South Africa. Indeed some 625 British soldiers were infected during the Boer War of 1899-1902, and of these in 1914 no fewer than 359 were still on the sick-list.

Early in the World War, when British troops were dispatched to Egypt, Sir Alfred Keogh, director-general of the A.M.S., sent a mission there to investigate bilharziosis. At the head of it was Lt.-Col. R. T. Leiper, helminthologist to the London School of Tropical Medicine. Leiper's object was to discover the intermediate host of the parasite which is the cause of this disease. The parasite itself had already been discovered, as early as 1852, and was called after its discoverer T. Bilharz, a German. There was, moreover, some reason to suppose that a portion of its life-history was passed in the body of a fresh-water mollusc, this being a usual cycle among trematode worms (see 27.240). Leiper adopted the simple measure of engaging a large number of native boys and paying them to collect all the molluscs they could find. The boys brought in large quantities, and the research workers set themselves to examine them. Within a very short period the parasite of bilharziosis was found in the body of one variety, a water-snail which inhabits canals and pools and is thus found "at spots daily frequented, such as the praying ground at the embankment crossing, in front of the cafés, and at the bend of the canal daily used for washing." The next step was to discover whether animals could be infected experimentally. Leiper observed that rats and mice and other vermin were notably scarce in the regions infested by the snails. A professional rat-catcher was employed but he failed to secure any animals. On June 13 1915 the first positive result was obtained when a rat was experimentally infected. Various experiments were now undertaken to determine the mode of infection of human beings. It was found that both drinking and bathing are dangerous for the free-swimming parasites. "Cercariae," after they have been born from the body of the water-snail, are so provided that they are able to pierce the human skin and so enter the body. Happily they live only 36 hours after birth in the pools, dying thereafter unless they find a suitable host.

The life-history of the parasite is therefore a double one. It lives in the bodies of men from which it is passed to water where it enters the water-snail's body. From this after six weeks it is hatched in the free-swimming form and then re-enters the bodies of men. The snail is safe until six weeks from its first infection have elapsed. It retains its powers of dissemination over considerable periods. The following conclusions were formulated:

1. Transient collections of water are quite safe after recent contamination.
2. All permanent collections of water such as the Nile canals, marshes and *birkeh*s (pools) are potentially dangerous, depending on the presence of the essential intermediary host, the snail.
3. The removal of infected persons from a given area would have no effect, at least for some months, in reducing the liability to infection, as the intermediate hosts discharge infective agents for a prolonged period.
4. Infected troops cannot re-infect themselves or spread the disease directly to others. They could convey the disease to those parts of the world where a local mollusc could efficiently act as carrier.
5. Infection usually takes place both by the mouth and through the skin. Recently contaminated moist earth or water is not infective.
6. Infection in towns is acquired from unfiltered water, which is still supplied even in Cairo, in addition to filtered water, and is delivered by a separate system of pipes.
7. The eradication can be effected without the co-operation of infected individuals by destroying the molluscan intermediaries.

The irrigation work in Egypt being in the hands of the Government, it is possible to have the pools in which the snails breed drained and dealt with. Along such lines, at least, lie the preventive measures which will in course of time be instituted. Through Leiper's work, therefore, this disease may be regarded as much less of a menace than it has ever been formerly.

The great success which attended this work caused other investigators to turn their attention to the disease and to begin the search for a cure. Many remedies had, of course, been tried, but none of these could be guaranteed to eliminate the parasites and so to end the mischief. It occurred to Dr. J. B. Christopherson to apply to this disease the method of using antimony tartrate which had been employed with success in the treatment of the Indian disease kala-azar. This consists in giving the antimony by injection into a vein. Christopherson soon found that his idea was to be relied on and that the effect far exceeded his hopes. The parasites and their ova were killed off and the patients became entirely free of the disease. This work has now passed beyond the stage of experiment, and Christopherson's treatment is universally acknowledged to be a complete cure of bilharziosis.

Thus this formidable disease has been conquered. Its means of transmission are known. Its prevention is only a matter of time. Its cure is a matter of certainty. (R. M. Wi.)

**BINYON, LAURENCE** (1869- ), English poet (see 3.952), produced after 1920 a book on Botticelli (1913); a catalogue of Japanese woodcuts in the British Museum (1917); *The Art of Asia* (1915); *English Poetry in Relation to Painting and other Arts* (1918); *For Dauntless France* (1918) and *Court Painters of the Great Mogul* (1920); as well as certain collections of poems, *Auguries* (1913) and *The Four Years* (1919), the last of which gathered together his fine war poems, which had previously appeared in several smaller collections. In 1920 his play *Sakuntala* was performed in London.

**BIRDWOOD, SIR GEORGE CHRISTOPHER MOLESWORTH** (1832-1917), Anglo-Indian writer (see 3.979), died at Ealing June 28 1917.

**BIRDWOOD, SIR WILLIAM RIDDELL, BART.** (1865- ), British general, was born Sept. 13 1865. He joined the 12th Lancers in 1885 and was in the following year transferred to the Indian staff corps, joining the cavalry. He served in the Hazara expedition of 1891 and the Isazai expedition of 1892, and in the 1897-8 frontier war. He was sent to South Africa in 1899 and served on the staff there during the whole of the war, the close of which found him a brevet lieutenant-colonel. He was afterwards closely associated for several years with Lord Kitchener in India, acting as his military secretary. In

1908 Birdwood, now a full colonel, held the position of chief staff-officer during the operations against the Mohmuds, for which he received the D.S.O., and he was a brigade-commander in India from 1909 to 1912. He had been promoted major-general in 1911; and in 1912, after holding for some months the position of quartermaster-general at Simla, he was appointed Secretary in the Army Department. Lord Kitchener in Dec. 1914 selected him for the command of the Australasian forces which were being assembled in Egypt, and in the following April he commanded the army corps from the Antipodes which carried out the memorable landing at Anzac. He was in charge of the troops clinging to this patch of the Gallipoli Peninsula until Aug., and he then directed the unsuccessful offensive that was attempted from it. His personality had made him much liked and respected by the Australasian troops. After the change that took place in the control of the Mediterranean field force in Oct., Birdwood (who had been awarded the K.C.M.G. and had been promoted lieutenant-general) assumed charge of the forces operating at the Dardanelles, and he carried out the very successful withdrawal of the troops from their dangerous positions in the following December and January. After a short period in Egypt he took his Australasian troops to the western front, and he commanded them there for two years; he was given the K.C.B. and promoted general in 1917. On the reconstitution of the V. Army after the great German effort of the spring of 1918 had been checked, Sir William Birdwood was selected to lead it, and his troops bore an important part in the last phases of the British advance in the autumn. For his services he was made a baronet and a G.C.M.G., besides receiving a grant of £10,000. He paid a visit to the Antipodes a year after the war and received a great welcome; in 1920 he took up command of the northern army in India.

**BIRKENHEAD, FREDERICK EDWIN SMITH, 1st Viscount** (1872- ), Lord Chancellor of Great Britain, the son of a barrister, was born at Birkenhead July 12 1872, and was educated at the local school, whence he proceeded with a classical scholarship to Wadham College, Oxford. He gained a first class in jurisprudence in 1895 and was Vinerian Law Scholar in 1896, was elected a Fellow of Merton and did a considerable amount of educational work in the next few years, being a lecturer both at Merton and at Oriel, and an extension lecturer in modern history both for Oxford and for Victoria University. But his attention was mainly directed to law and public life. He had been president of the Union at Oxford, and he entered at Gray's Inn, being called to the bar in 1899. He went the northern circuit, and attached himself to the local bar at Liverpool, where he rapidly obtained a considerable practice. He also published a book on international law, which has gone through several editions. He soon took a prominent place among the Conservatives of Liverpool as a decided Tariff Reformer, and was returned for the Walton division in Jan. 1906, holding the seat till his elevation to the Chancellorship in 1919. When he entered the House of Commons, he found himself a member of a small and discouraged minority, who had been soundly beaten at the general election, mainly on the issues of tariff reform, Chinese labour in the Transvaal, and religious education. He himself, though he had achieved considerable local reputation, was practically unknown in London. Within a week of the opening of Parliament he bounded into fame by a sparkling maiden speech in a Tariff Reform debate—a speech conceived in a confident fighting spirit, calculated to cheer dejected partisans, and full of wit and epigram. One of his phrases went home, when he described the majority as “begotten by Chinese slavery out of Passive Resistance.” Mr. Lloyd George, who followed him in debate, spoke of the speech as very brilliant; and the Conservative party hailed him at once as a coming leader. He soon acquired a large practice at the bar in London, took silk in 1908, and became a bencher of his Inn. In Parliament, during the year of Opposition, he justified the expectations formed of him, but incurred the animosity of his opponents by the vehemence of his denunciation of ministerial schemes. He was chosen to move the rejection of the

Parliament bill on the third reading in May 1911. In the crisis which followed he took an extreme view, was prominent in the disorderly proceedings when Mr. Asquith was refused a hearing in the House of Commons, and threw in his lot with the “Die-hards.” At the coronation in that year his growing reputation in Parliament was recognized by his admission to the Privy Council; and in 1912 he appeared as an acknowledged leader of the party, moving the Opposition amendment to the Address, and the rejection of the Welsh Disestablishment bill on second reading. He showed, moreover, as a Liverpool man, his strong sympathy with Ulster, threatened by the Home Rule bill; he went over to Ireland and constituted himself Sir Edward Carson's principal lieutenant in the resistance which he was organizing in North-East Ulster against Home Rule.

When the World War broke out, he was one of the first Opposition leaders to place his services at the disposal of the Government. He accepted the position of head of the Press Bureau, and in that capacity encouraged, with a view to accelerate enlistment, the publication in *The Times* of Aug. 30 1914 of a telegram showing the serious plight of the British army after the retreat from Mons. But he went shortly afterwards to France on active service, with the Indian Corps, and was mentioned in despatches. He was captain in the King's Own Oxfordshire Hussars, and a temporary lieutenant-colonel in the army. When the first Coalition Ministry was formed in May 1915, he was appointed Solicitor-General and knighted, and he succeeded Sir Edward Carson in November as Attorney-General, a post he held till 1919. The Defence of the Realm Act and other war-time measures threw in these years a great burden of anxious work on the law officers of the Crown, including the prosecution of Sir Roger Casement for high treason at the Old Bailey. In the autumn of 1918 Sir Frederick Smith undertook a visit of propaganda to the United States, and published a book about it on his return. When Mr. Lloyd George reconstructed his Ministry after the general election of Dec. 1918, the Attorney-General was appointed Lord Chancellor and created a peer. The appointment, though quite in the normal course of promotion, was subjected to considerable criticism, owing partly to his comparative youth, but chiefly to his vehement partisanship in earlier years. But it was soon admitted (and notably by his colleagues on the judicial bench) to have been amply justified. Lord Birkenhead brought to the performance of his new duties the vigour which had always been characteristic of him; his judgments in the two final Courts of Appeal were weighty and lucid; and he quickly made himself a force in the Lords' debates. His zeal for the efficient administration of justice caused him, in addition to his other heavy work, to sit during several weeks in the spring of 1921 as a judge of first instance, in order to clear off the enormous arrears in the Divorce Court. He was created a viscount on the King's birthday in that year.

He married, in 1901, Margaret Eleanor, daughter of the Rev. Henry Furneaux, a well-known Oxford scholar, his family consisting of a son and two daughters. He was always a man of much physical activity, fond of a horse, of field sports and games, and of yachting.

**BIRMINGHAM, GEORGE A.**, pen-name of James Owen Hannay (1865- ), Irish novelist and playwright, who was born July 16 1865 at Belfast. He was educated at Haileybury and Trinity College, Dublin, was ordained and became a canon of St. Patrick's, Dublin, in 1912. He wrote amongst other novels: *The Seething Pot* (1905); *Spanish Gold* (1908); *Lalage's Lovers* (1911); *The Red Hand of Ulster* (1912); *The Lost Tribes* (1914) and *Insheeny* (1920), whilst among his plays the best known is *General John Regan*, which was successfully produced at the Apollo theatre, London, in Jan. 1913.

**BIRMINGHAM**, England (see 3.983).—During 1910-21 the city of Birmingham greatly increased in size and importance. The primary cause of its growth in area was the extension of the municipal boundaries by a local Act of Parliament, though manufacturing enterprise and industrial developments before the World War, as well as the extraordinary influx of munition

workers in 1914-8, materially contributed to the increase in the population. For the purposes of the report of the medical officer of health published in 1920, the population was estimated to be 910,000. When the census was taken in 1911 the males over 18 years of age numbered 246,881 and the females 283,366. Just prior to the Armistice the number of men of or over military age in the city had been reduced to 200,251, while the number of women residing in the city had increased during the war to 323,911. The war probably accounts largely for the falling-off in the birth-rate during the same period. In 1913 the rate was 27.3 per 1,000 and in 1918 the figure was 19.4. The intervening years show proportionate decreases. There were 19,335 babies born during 1919. This is equal to a birth-rate of 20.9 and indicates an upward tendency, though the increase of population is due more to the improvement in the death-rate than to the recovery of the birth statistics.

The Greater Birmingham scheme, the prospect of which in 1910 had greatly disturbed the authorities of the counties of Warwick, Worcester and Stafford, became an accomplished fact in 1911. Although the area taken into the city included a considerable amount of agricultural and undeveloped land in the county of Worcester, the residential suburbs annexed to the city in 1911 were mainly populated by people who derived their incomes, as well as their water, gas, electricity and other urban amenities, from the city.

The borough of Aston Manor, the urban districts of Erdington and Handsworth, almost all of the urban district of King's Norton and Northfield, and the rural district of Yardley were added to the city at this time. King's Norton and Northfield, as parts of Birmingham, ceased to be portions of Worcestershire from the geographical as well as from the administrative aspect, and came nominally within the new boundary of Warwickshire, as did Handsworth, from Staffordshire.

The area of the city was increased from 13,477 ac. to 43,537 ac., or about 68 sq. m., and the rateable value of Birmingham rose automatically from £2,963,711 to £4,340,017, leaving out of account the differential rate for various periods granted to certain of the added areas.

The membership of the city council was at the same time increased to 30 aldermen and 90 councillors, representing 30 wards. Judged by municipal standards, Birmingham was in 1921 the largest city in England.

**Public Health.**—In the decade immediately preceding the war the death-rate was 14.8 per 1,000, and for the five years from 1915 the figures declined from 14.4 to 13.0 in 1919. The death-rate was in 1921 the lowest but one among the large towns of Great Britain. One of the principal causes of Birmingham's comparatively clean bill of health, and the decline in infantile mortality, is the employment by the health committee of a large and highly organized staff of lady health visitors. The city is divided into four quarters, each of which is under the supervision of an assistant medical officer of health or a lady doctor, the latter specializing in maternity and child-welfare work. The Corporation also employs specialists in tuberculosis, who have urban dispensaries and country sanatoria in their charge. The lady health visitors include 13 who have charge of tuberculosis cases, 19 who deal with the general health of certain congested areas, and 54 who are specially concerned with infant welfare, making a total of 86 lady health visitors.

**Housing.**—In Oct. 1919 the Corporation submitted a return to the Local Government Board showing that 14,000 new houses were at that time required to meet the unsatisfied demand, and that 50,000 new houses would be required to rehouse persons displaced by the clearance of insanitary areas, and to replace other dwellings which fell definitely below a reasonable standard. Prior to that date, however, the Corporation (July 1918) formulated a policy for dealing with the housing question and a number of proposals then suggested were incorporated in a local Act and in the Government's Housing Act of 1919. In the following winter the Corporation acquired approximately 1,050 ac. of land upon which some 10,000 houses could be erected. Other large estates were subsequently purchased, and the Corporation was in 1921 in possession of about 1,930 ac. of land for housing purposes. This land would accommodate from 19,000 to 20,000 houses. In Sept. 1919 a housing director was appointed and a considerable proportion of the houses had in 1921 been completed and occupied. Difficulty was found in obtaining a satisfactory supply of labour and materials. This not only delayed completion of the houses but seriously affected the cost of erection, the average for the first four schemes being about

£900 per house, the cost of the land and other expenses brought it up to over £1,000. By the end of Jan. 1921, contracts were placed for 2,386 workmen's dwellings. Of these 180 houses were built by direct labour. The Corporation also converted army huts at Castle Bromwich into dwellings for about 100 families.

**Town Planning.**—Birmingham was the first large town in England to prepare a comprehensive scheme of town planning. Important pioneer work in this direction was done by Mr. J. S. Nettelford when he was chairman of the Birmingham housing committee, before the passing of the Town Planning Act of 1909. No definite steps to carry out this scheme were possible until the extension of the city in 1911, when 24,000 ac. of undeveloped land in the suburbs were brought under the control of the city council and Mr. Neville Chamberlain became chairman of the town-planning committee. The first town-planning scheme authorized by the Local Government Board related to Harborne and Quntun, and dealt with 2,320 ac. on the W. side of the city. The future line of main roads was defined, some of them being 100 ft. wide, and the owners of the adjoining land were notified that they would have to conform to a general layout affecting the construction and character of the side roads (which may be narrower and less expensive) and the number of houses and kind of buildings to be erected in the area. Open spaces and allotment sites were reserved. No factories were provided for in this area but considerable space was reserved for them in the E. Birmingham town-planning scheme (1,443 ac.), where the greater part of the property is already industrial and the prevailing winds blow the smoke away from the city. These two schemes were approved in 1913. The N. Yardley scheme of 3,176 ac. and the S. Birmingham scheme of 8,267 ac. were prepared before the war and approved in 1916. A supplementary scheme for S.W. Birmingham, involving an area of 9,866 ac., was launched after the war. The public works and town-planning committee also prepared tentative plans for improving the built-up area in the centre of the city, and widening the arterial roads. They have experimented with a sleeper tramway track between two carriage-ways, with wide grass margins and avenues, and are providing specially for fast-travelling vehicles on a ring road and arterial roads, which are to be widened to 100 ft. or more. The first sections of road so widened were completed in 1915 at Edgbaston and Harborne. The scheme includes the widening of 43 m. of radial main roads and the construction of 7 m. of new roads. During the trade slump of 1920-1 large numbers of unemployed were engaged in this work of road widening and the construction of new roads. Similar labour was employed on laying out a municipal park in an open space known as Warley Woods and another course on land given by members of the Cadbury family on the Leckey hills. Another important addition to open spaces around the city is Barr Beacon given by Col. J. H. Wilkinson during the World War.

**New Buildings.**—The building of the new municipal offices and art galleries on a portion of the Colmore estate, bounded by Edmund St., Congreve St., Gt. Charles St. and Margaret St., which began in 1906, was completed in 1912. The offices of the gas, health, tramways and education departments were transferred from the old council house to the new premises and the rooms thus vacated were utilized for the accommodation of the water department, public works department, town clerk's department, salvage department, parks department and the new Municipal Bank.

A legacy of £50,000 from Mr. John Feeney, who had been a generous donor to the museum and art gallery, was utilized for the erection of a handsome suite of picture galleries and a museum of casts over the new municipal offices and connected with the old art gallery by a bridge across Edmund Street. The natural history museum was established at the same time, and a unique collection of British birds with their nests and perfectly natural surroundings was provided as a memorial to the late Alderman C. G. Beale. The first of the new Feeney galleries is devoted to the work of modern English painters and contains some of the larger pictures, such as Millais' "Widow's Mite," Lord Leighton's "Condottieri," Henry Moore's "Newhaven Packet," "Autumn" by Sir L. Alma-Tadema, "The Village Philharmonic" by Stanhope Forbes, "Hayle from Lelant" by Sir Alfred East. Gallery II. contains old masters and portraits of local worthies, including excellent examples by Reynolds and Gainsborough. The next three galleries are filled with works of the English pre-Raphaelites, notably those of Sir Edward Burne-Jones, a native of Birmingham. This collection, both in size and importance, is unrivalled. Another interesting gallery is No. VII, which includes Turner's beautiful drawing "Schaffhausen," from the Ruskin collection, and other important water-colours. A large collection of drawings by David Cox and other local artists is in galleries VIII. and IX. The old galleries are now mainly devoted to decorative and industrial art, including the Feeney collection of nearly 2,000 pieces and several important collections on loan. One of the new galleries is reserved for loan exhibitions of pictures.

In 1914-6 a new parcel post-office was erected on the site of the old Inland Revenue office in Paradise Street. This several plain structure, built by the Office of Works during the war, is connected with the post-office in Victoria Sq. by a massive stone bridge across the top of Hill Street. The Inland Revenue offices were transferred to Empire House, Gt. Charles Street. The galleries

of the Royal Society of Artists were rebuilt on modest lines, and the classic portico which was a striking architectural feature of New St. disappeared to make room for utilitarian shop fronts. Queen's College remains an ornament to Paradise St., though it was used in 1921 mainly for commercial purposes instead of for theological training, owing to the exigencies of ecclesiastical finance. The Repertory theatre in Station St. was erected in 1913 through the munificence of Barry V. Jackson, founder of the Pilgrim Players, and the enthusiasm of John Drinkwater, the playwright.

"Highbury," Moor Green, formerly the residence of Mr. Joseph Chamberlain, and the adjoining residence, "Uffculme," the home of the late Mr. Richard Cadbury, were during the war converted into orthopaedic hospitals for disabled soldiers. When they ceased to be under the control of the Ministry of Pensions they were reverts to the Corporation as gifts from Mr. Austen Chamberlain and Mr. Barrow Cadbury. "Sorrento," Wake Green Rd., Moseley, was acquired by the citizens' committee during the war for the treatment of paraplegic war pensioners. The Princess Mary Convalescent Centre for Disabled Soldiers is at Rednal, and one of the city asylums at Rubery was still occupied in 1921 by the Ministry of Pensions for orthopaedic cases. The old Children's Hospital in Broad St. was used for various Government purposes during the war, and larger premises were provided by voluntary contributions, with up-to-date equipment for the treatment of sick children, in Ladywood Road. A hospital for nervous diseases was established after the war at Edgbaston.

**Libraries.**—Several important additions have been made to the public libraries of the city. In addition to the central reference and lending libraries, which adjoin the Midland Institute, there were in 1921 21 branch lending libraries and news-rooms, two branch reference libraries, a reading-room at Witton and a delivery station in the outlying district of Quinton, as well as a new commercial library and a patent library in the council house. The central reference library contains nearly 300,000 volumes, including the well-known Shakespeare Memorial Collection of 17,000 volumes, of which a separate catalogue was printed in 1903; the Birmingham collection, of which a 140-page catalogue was published in 1918, a collection of poetry relating to the World War; the Sir Benjamin Stone collection of photographs; large Byron, Milton and Cervantes collections and a collection of manuscripts and other relics of Boulton and Watt.

The lending libraries contain nearly 250,000 volumes, the annual users numbering about 2,300,000. The lending libraries were in 1921 being converted to the open-access system. An important innovation is the commercial library, containing about 3,000 volumes, the collection of trade catalogues and files of 220 periodicals, which was opened at the end of the war.

**Municipal Bank.**—The Municipal Bank, which was established mainly through the efforts of Mr. Neville Chamberlain when he was lord mayor, loaned £300,000 to the Government during the war, this amount being invested in small sums by 30,000 depositors, who were all employed persons. Owing to the opposition of the joint-stock banks through their parliamentary representatives in 1915, the operations of the bank were severely limited during the war, but its success in promoting thrift among the working-classes induced Parliament to extend its powers in 1919 and in that year over £300,000 was transferred from the war-time organization to a permanent municipal institution, the first of its kind in England.

**The University.**—A new chapter in the history of the university of Birmingham began with the visit of King Edward VII. and Queen Alexandra to open the new buildings at Edgbaston on July 7 1909. The site, given by Lord Calthorpe, the principal landlord of the district, comprises 40 ac., near the Bourne Brook and about 3 m. from the Mason College (in the centre of the city) where the faculties of art, medicine and the department of education are still carried on. The new buildings designed by Sir Aston Webb, mainly for the technical side of the university, cover a large semicircle and its diameter, with a central tower 325 ft. high, erected to commemorate the foundation of the university by its first chancellor, Mr. Joseph Chamberlain. The great hall and workshops, laboratories, model mine and power station for the engineering and allied departments were lavishly equipped to meet the special needs of the district, but the financial stringency arising out of the war has prevented the erection of the other large buildings necessary to make the design symmetrical, and to complete the accommodation for the chairs contemplated when the scheme was launched. The faculties of sciences (pure and applied) and of commerce are now housed on the Edgbaston site.

In 1919 the Treasury grant was increased to £38,000; the city council now contributes £15,000 per annum; and in 1920-1 a public appeal for funds resulted in about £300,000 being raised for the purpose of reducing the debt on the university and to increase the efficiency of the existing departments, though the amount

available for these purposes was reduced by the fact that about £147,000 of the above-mentioned total was ear-marked for special objects, some of which involved additional expenditure out of the university funds. The chairs, lectureships, etc., endowed since 1910 include physics, electrical engineering, metallurgy, town planning, agricultural zoology) a research department subsidized by the Board of agriculture), Russian, Italian and brewing. Some of these new endowments are attached to old professorships. For instance, Sir George Kenrick endowed the physics chair in memory of the late Prof. J. H. Poynting, who had occupied it ever since Mason College was opened in 1880, 20 years before the university charter was granted. Public subscriptions endowed the pioneer chair of electrical engineering, which thus became in 1913 a memorial to the first vice-chancellor (Alderman C. G. Beale). The chairs allotted to modern European languages are quite new and the appointment of a lady as Italian professor is also an innovation. The chamber of commerce was responsible for the establishment of a chair of Russian during the war. The school of brewing has been supported by the trade ever since the foundation of the university, but the chair was not permanently endowed until 1919.

Lord Robert Cecil succeeded the late Mr. Chamberlain as chancellor in 1918; Sir Gilbert Barling was elected vice-chancellor in place of the late Alderman Beale in 1914, and Mr. C. Grant Robertson, Fellow of All Souls College, Oxford, was appointed principal on the resignation of Sir Oliver Lodge in 1919. Other important recent events in connexion with the university were the granting by its council of 15 free entrance scholarships for Birmingham residents (1912); the erection of a women students' club adjoining Mason College (1914); the transformation of the new buildings into a military hospital, and the women's hostel into a nurses' home during the war; and the subsequent linking-up of Birmingham with Bristol and the northern universities for matriculation and parliamentary purposes. The library was in 1921 being reorganized and enlarged.

The volumes accessible to students number about 100,000. The teaching staff increased from 117 in 1910 to 216 in 1920, and the number of full-time students from 938 to 1,754 in the same period.

It is a distinctive feature of Birmingham among modern universities that it does not include in its membership part-time students, these being provided for at the Midland Institute and the Municipal Technical School. On the other hand the university gives generous help to the Workers' Educational Association, both through its governing body and through individual members of the teaching staff. The income of the university increased from £57,143 in 1910 to £114,434 in 1920 and its expenditure from £69,780 to about £118,320. In consequence of the generous response to the appeal made in 1921 the council and senate hoped to make further additions to the salary list and the curriculum in the near future.

**Commerce and Manufactures.**—After the war the Birmingham chamber of commerce entered into possession of the Colonnade hotel in New St., converted into a commodious suite of offices and conference-rooms. The enormous iron-and-glass structure erected by the Government on the Corporation playing fields at Castle Bromwich, for use in connexion with the aerodrome established there during the war, provided in 1921 excellent accommodation for the Birmingham section of the British Industries Fair.

Other large buildings erected during the war facilitated the development of local industries. Fort Dunlop is an entirely new suburb occupied by the makers of tires, golf balls and other rubber goods. The new factories erected by large firms now amalgamated in the Vickers-Metropolitan group have been converted from the manufacture of tanks, Handley-Page aeroplanes, artillery limbers, ambulances and engines-of-war into the more peaceful occupations associated with the production of railway carriages, wagons and electrical apparatus of all kinds. Some idea of the revolution in local industries produced by the war may be gleaned from the fact that a Birmingham firm of penmakers in the early stages of the war contracted to produce 12 million cartridge clips and that another firm in the jewellers' quarter made 72 million army buttons in one year. Under the direction of a local munitions committee, before the establishment of the Ministry of Munitions, the smaller manufacturers in the city were affiliated to the national shell factory at Washwood Heath, where the shells were produced in the rough and finished in the smaller workshops. The output of shells in Birmingham during the last two and a half years of the war was 15 millions. Fuses and munitions for quick-firing guns were produced in even larger quantities, the local engineers and cycle-makers being specially qualified for the precision work required for these munitions. The manager of the Birmingham gas department acted as secretary of the munitions committee, and also organized the manufacture of toluene as an ingredient for high explosives throughout the country. At the B.S.A. works 10,000 rifles and 2,000 Lewis guns per week were manufactured. From the returns of the Ministry of Munitions it appears that, although the weight of shells produced in Birmingham was not the heaviest on record, the number and variety of articles supplied for the use of the army, navy and air force in Birmingham was greater than in any other part of the country. Some of the smaller parts produced for engines-of-war by the local brass manufacturers were measured at the Government depots in thousands of millions.

**War-time Activities.**—During the first month of the World War three city battalions were raised by the Lord Mayor, and the recruits under the voluntary system overflowed into several other new battalions of the Warwickshire regiment. It is estimated that Birmingham contributed to the fighting forces of the nation at least 148,000 men. Over 11,000 Birmingham men were killed, and the long list of local military distinctions includes the names of 11 winners of the V.C. The amount of money for the prosecution of the war raised in four separate weeks of special War Loan campaigns was £26,368,879, exclusive of several millions invested by the Corporation and local companies. Individuals and trade unions through the banks and post-office.

Birmingham was the first city to put into operation a comprehensive food-rationing scheme, and this scheme afterwards became the basis of the plan adopted by the Government for the whole country.

At the university buildings at Edgbaston, which were the headquarters of the 1st Southern General Hospital, 1,358 beds were provided and at the branch hospitals further accommodation was provided until there was a total of 6,168 beds. In addition to the 64,000 wounded men treated at the university 20,000 patients were received at the Poor Law infirmary in Dudley Rd., 8,000 in elementary schools at Stirchley and King's Heath, 3,000 at the Monyhill Colony belonging to the board of guardians and at A. D. and civilian hospitals 5,000, making a total of over 100,000 military and naval patients. These huge figures do not include the record of the 1st and 2nd Birmingham War Hospitals, which were established under an arrangement with the asylums committee of the Corporation. At the Rubery and Hollymoor Mental Hospitals 36,795 wounded men, mostly orthopaedic cases, requiring special treatment, were nursed back to health.

The fact that Birmingham was one of the most important munition-making centres in England being well known to the Germans, they naturally made efforts to bomb the city from the air. For some time they were unsuccessful, owing to the severe lighting restrictions enforced by the chief constable in conjunction with the Home Office. Zeppelins, which caused serious destruction and loss of life in the Black Country on Jan. 31 1916, passed over the city without doing any damage. In consequence of representations made to the Government by the Lord Mayor of Birmingham on behalf of the municipalities of the Midlands, more effective means were taken to warn the inhabitants of impending air raids, and the anti-aircraft defences were also considerably improved before the next Zeppelin raid, which took place on Oct. 19 1917. On this occasion bombs were dropped on the Austin works at Longbridge, near the city boundary, but little damage was done. The third and final air attack on Birmingham took place on April 12 1918, when five Zeppelins set out to bomb the industrial towns of the Midlands. L60 made direct for Birmingham, but timely warning was received at the headquarters of the Birmingham anti-aircraft defence in Newhall St., and when the airship was passing over Coventry it was met by gunfire and searchlights. These caused the raider to drop bombs in the open country in order to lighten his ship. When passing over Hockley Heath, just outside the city boundary, at an altitude of about 5 m., L60 became an illuminated target for at least one of the Birmingham anti-aircraft guns. When the second and third Birmingham guns came into action the enemy turned tail, dropped two bombs, the first on the Robin Hood golf course and the other near Manor Farm, Shirley, and made a rapid retreat over Lapworth.

In addition to the thousands of Birmingham women who worked on munitions, 15,000 migrated into the city during the war. The Birmingham women's war agricultural committee, the women's volunteer reserve and the various naval and military auxiliaries also found employment for hundreds of girls. Among the many voluntary organizations in which ladies played a leading part, special mention should be made of the lady mayors' depot, from which 273,553 garments and other articles were sent to soldiers at the front and in hospital, and 130,162 parcels were sent to 1,531 prisoners of war, the depot being the regimental care committee for the Warwickshire regiment. The war hospitals supply branch of the depot, which was established in March 1916, supplied 827,176 surgical requisites to the war hospitals. The war refugees committee and the citizens' committee were also mainly composed of women, the latter organization being responsible for a remarkable network of agencies for the relief of all kinds of civilian distress arising from the war, and for meeting the needs of soldiers' families and men broken in the war. (E. S.)

**BIRRELL, AUGUSTINE** (1850— ), English author and politician (*see* 3.980), continued to be Chief Secretary for Ireland till the Dublin rebellion of Easter 1916, over nine years in all—a tenure of exceptional length of this particular office. The cattle-driving agitation died down, and Irish politics, save for labour troubles, were comparatively quiet, till the two general elections of 1910 had once again made retention of office by the leaders of the Liberal party dependent on the Irish vote. A third Home Rule bill was now inevitable, and Mr. Birrell spent much of the

autumn of 1911 in preparation for it, being cheered by the appreciation of him shown by his young Scottish fellow-countrymen in his election to the Lord Rectorship of Glasgow. The main conduct of the bill was, however, taken out of his hands in the sessions of 1912, 1913, and 1914 by Mr. Asquith, the Prime Minister; but he frequently wound up the debates, and was largely responsible for the treatment of details in committee. When resistance was organized in Ulster, when volunteers were enlisted and drilled in the province, and a provisional government constituted, he adopted the *laissez-faire* attitude which had throughout been the mark of his Irish administration; and he applied the same treatment to the Irish volunteers who were raised in reply in the Sinn Fein and Nationalist interest. In all the earlier discussions in Parliament, he made light of the Ulster difficulty, and was frequently betrayed into inappropriate flippancy. Talking of Ulster and religious bigotry, he said that he had his own views of ecclesiastics; he had been in close touch with cardinals and archbishops, and "commended them all to God." But towards the end of the debates, he adopted a worthier manner, and advocated a national solution, and settlement by consent. In a striking phrase in the debate on the address in 1914, he spoke of a new Ireland, not necessarily Home Rule or Nationalist, but "the renaissance of a nation." When the World War broke out the controversy about Ulster was stilled as Home Rule was in abeyance, and in the Coalition Government of 1915 Mr. Birrell had Sir Edward Carson as a colleague, and would have had Mr. Redmond also had Mr. Redmond consented to accept Mr. Asquith's invitation. The danger with which he had to cope now came not from Orangeism or constitutional Nationalists, but from extremists of the Sinn Fein, Irish-American and Irish Labour parties, of whom Casement and Larkin were the apparent leaders. They promoted a strong and largely successful propaganda against enlistment in Ireland, which he entirely failed to extinguish, and which culminated suddenly in open rebellion at Easter 1916 (*see* IRELAND, HISTORY). Immediately after the suppression of the rising Mr. Birrell resigned, rather plaintively explaining that he was aware that he had run grave and considerable risks in not tackling Sinn Fein, but that he had subordinated everything in order to maintain unbroken the front of Ireland towards the enemies of the Empire. His retirement from office was followed by retirement from Parliament in 1918. He resumed his literary work, and published in 1920 a life of his father-in-law, the poet Frederick Locker-Lampson. His wife died in 1915.

**BISSOLATI-BERGAMASCHI, LEONIDA** (1857-1920), Italian statesman, was born at Cremona Feb. 20 1857. The son of Demetrio Bergamaschi, he was adopted by, and took the name of, his stepfather, Prof. Bissolati, the philosopher. At an early age he became a Socialist through his genuine sympathy with the lot of the poor, and an active member of the Italian Socialist party from its foundation in 1892. He exercised considerable influence as a journalist, editing the weeklies *La Critica sociale* and *La Lotta di classe*, and then the daily official organ of the party, *L'Avanti*. In 1897 he entered Parliament as member for Pescarolo; he afterwards was elected for Budrio and then for the second division of Rome (1908), which he represented until his death. Although a firm believer in the Socialist doctrine, Bissolati became more and more dissatisfied with certain aspects of the policy of the party, notably with its anti-patriotic attitude at the time of the Libyan War. In 1911 the split came, and Bissolati, together with Bonomi and some other leading Socialists, seceded from the party and formed what was known as the Reformist Socialist group, which supported the Giolitti Cabinet in its African policy on its promise of democratic reforms. At the outbreak of the World War Bissolati did not hesitate, and from the first declared himself in favour of Italian intervention on the side of the Entente against German militarism, whereas the "official" Socialist party was frankly neutralist and pro-German. When Italy entered the war he joined the army as a sergeant of the Alpini and was wounded and decorated for valour. In June 1916 the Boselli national Cabinet was constituted and Bissolati accepted office as minister without portfolio,

acting as a kind of intermediary between the Cabinet and the army. After the Armistice he resigned (Dec. 1918) owing to disagreements with Sig. Orlando's Government over the Pact of London. He was opposed to the annexation by Italy of the Alto Adige because of its German population, and of North Dalmatia with its Slav majority; but he advocated the annexation of Fiume as a purely Italian town. His attitude on the Alto Adige and Dalmatian questions lost him the popularity he had hitherto enjoyed with the majority of the nation, and his speech at Milan on the League of Nations, in which he set forth these views, was unfavourably received. He came in for severe criticism for having, at a moment when Italy's representatives found their country's aspirations challenged at every turn by the Allies, to some extent given away the Italian case and provided opponents with arguments from the mouth of an Italian exponent. At the same time everyone recognized his sterling qualities of honesty and genuine patriotism; however much people might disagree with his views, there was no doubt that he was inspired solely by what he believed were his country's best interests and noblest traditions, and his death at Rome on May 6 1920 was deeply regretted by all, regardless of party divisions.

**BITTER, KARL THEODORE FRANCIS** (1867-1915), American sculptor (see 4.13), died in New York April 10 1915. In 1911 he finished a model designed for the Henry Hudson monument. He was director of sculpture at the San Francisco Exposition (1912-5), and at the time of his death was president of the National Sculpture Society.

**BJERKNES, VILHELM** (1862- ), Norwegian physicist, son of Carl Anton Bjerknes, professor of mathematics in the university of Christiania, was born in 1862, and was educated at the university of Christiania. He became at a very early age assistant to, and collaborator with, his father, who had discovered by mathematical analysis the remarkable apparent actions at a distance between pulsating and oscillating bodies in a fluid, and their analogy with the electric and magnetic actions at a distance. Apparently no attempt had been made to demonstrate experimentally the theories arrived at by the older professor until his son, then a lad of about 17 or 18 years of age, turned his mathematical knowledge and remarkable mechanical genius to the devising of a series of instruments, by which all the well-known phenomena of electricity and magnetism were illustrated and reproduced, by spheres and discs and membranes, set into rhythmic vibration in a bath containing a viscous fluid such as syrup. These remarkable demonstrations formed the most important exhibit in the department of physics at the Exposition Internationale d'Electricité held in Paris in 1881, and aroused the greatest interest in the scientific world.

The younger Bjerknes studied electric waves (1890-1) in Bonn, Germany, in the laboratory of Hertz, where he succeeded in giving the explanation of the phenomenon called "multiple resonance," discovered by Sarasia and De la Rive. Continuing his experiments at the university of Christiania (1891-2), he proved experimentally the influence which the conductivity and the magnetic properties of the metallic conductors exert upon the electric oscillations, and measured the depth to which the electric oscillations penetrate in metals of different conductivity and magnetic permeability (the "skin effect"). Finally he furnished (1895) a complete theory of the phenomenon of electric resonance, involving a method of utilizing resonance experiments for the determination of the wave lengths, and especially of the damping (the logarithmic decrement) of the oscillations in the transmitter and the receiver of the electric oscillations. These methods from that time have been in continuous use, and have contributed much to the development of wireless telegraphy. His papers on electric oscillations were published in *Annalen der Physik* (1891-5). In 1895, after he had been appointed to the newly created professorship of mechanics and mathematical physics at the university of Stockholm, where he had been lecturer since 1893, he returned to hydrodynamic investigations, pursuing them in two different directions. In his *Vorlesungen über Hydrodynamische Fern-*

*kräfte nach C. A. Bjerknes Theorie* (1900-2) he gave the first complete mathematical and experimental exposition of the discoveries of his father, whose age and excessive self-criticism had prevented him from finishing his work himself; and in a later book, *Die Kraftfelder* (1909), he stated the same theory in a very much generalized form according to methods of his own. On the other hand, he developed in 1898 the general law for the formation of circulations and vortices in a frictionless fluid, and began to apply the general vortex theory to atmospheric and oceanic motions. This attack upon the meteorological problems from a hydrodynamical point of view was after 1906 supported by the Carnegie Institution of Washington, of which he became a Research Associate. Two introductory volumes, *Statics and Kinematics*, of a greater work, *Dynamic Meteorology and Hydrography*, were published in 1913 under the auspices of the Institution.

In 1907 he was called back to the university of Christiania, where a personal professorship of mechanics and mathematical physics was created for him. In 1912 he was called to the university of Leipzig to create there a new professorship of geophysics and to organize, according to his own plans, a Geophysical Institute for atmospheric investigations. There, in 1916, he started the publication *Synoptische Darstellung atmosphärischer Zustände über Europa*; but in 1917 he returned to Norway, where he was attached, as professor of geophysics, to the new Geophysic Institute in the city of Bergen. He was the originator there of an improved and more scientific weather service, afterwards controlled by his son and collaborator, Jakob Bjerknes (b. 1897), which occasioned a new view of cyclones and anticyclones as waves in a surface of discontinuity separating air of polar from air of more equatorial origin, and cutting the ground along a line which can be followed on the weather maps, now generally called "the polar front." In 1893 Bjerknes married Honoria Bonnevie, who in earlier years assisted him much in his scientific work.

**BLACHE, VIDAL DE LA** (1845-1918), French geographer, was born at Pézenas, Hérault, Jan. 22 1845. He was educated at the Ecole Normale Supérieure in Paris, and entered upon the study of geography by way of that of history. The relations between geographical causes and historical effects were with him the subject of a life-study, the results of which are seen in one of his best-known works, the *Tableau Général de la Géographie de France* prefixed to Lavisse's *Histoire de France* (1903) and later republished separately; but he always refrained from pressing the theory of geographical "control" to an extreme. He joined the French school at Athens in 1867, and was thus enabled to travel extensively in Mediterranean lands. From 1872 to 1877 he was in charge, latterly as professor, of the department of history and geography at Nancy; from 1877 to 1898 he taught geography in the higher grades at the Ecole Normale Supérieure, and from 1898 to 1909 he held the chair of geography in the Faculté des Lettres at Paris. He lectured widely, and among his publications is the monumental *Atlas Général: Histoire et Géographie*, first published in 1894; he founded in 1891 and edited until his death the periodical *Annales de Géographie*, and contributed constantly to its pages. He died at Tamaris-sur-mer (Var) on April 5 1918.

**BLAKE, EDWARD** (1833-1912), Irish-Canadian statesman (see 4.35), died at Toronto March 1 1912.

**BLAKELOCK, RALPH ALBERT** (1847-1919), American painter (see 4.38) died near Elizabethtown, N. Y., in the Adirondacks, Aug. 9 1919. Because of insanity he was kept under restraint during the last 18 years of his life. In 1913 he was made an associate of the National Academy of Design and in 1915 a full member. In 1916 the Toledo Art Museum paid \$20,000 for his "Brook by Moonlight."

**BLINDNESS** (see 4.59).—In England legislators have been slow to recognize the claims of the blind. It is true that as far back as the reign of Elizabeth and onwards through the reigns of George III., William IV. and Victoria provision was made by way of maintenance or education, mostly through the Poor Law authorities, but this was totally inadequate. In 1839 the Report



of the Royal Commission on the Blind, the Deaf and the Dumb was published, and it would appear that the Elementary Education (Blind and Deaf Children) Act, 1893, was passed as a result. The Act made compulsory the education of blind children between the ages of 5 and 16, the responsibility falling upon the local Education authority for the district in which a blind child resides. The Education of Blind and Deaf-Mute Children (Scotland) Act was passed three years prior to the English Act. Powers in respect of the continuation of the education of the blind over the age of 16 are conferred on Education authorities under the Education Act, 1902, Part II., and the Education Act, 1918. The Post Office Act, 1908, provides that a warrant may fix special postal rates for embossed literature. Regulations making *ophthalmia neonatorum* notifiable came into force in 1914. In May 1914 Mr. (later Sir) Herbert Samuel, as president of the Local Government Board, appointed a "Departmental Committee on the Welfare of the Blind" to consider the condition of the blind in the United Kingdom and the means available for (a) their industrial or professional training, and (b) their assistance, and to make recommendations. This committee's report was issued in July 1917. As a result a special department dealing with the welfare of the blind was set up in the Ministry of Health, and an advisory committee appointed.

In 1920 the Blind Persons Act came into operation in the British Isles. It secures to blind persons in indigent circumstances, on attaining the age of 50, "old-age" pensions of 10s. per week; it places the responsibility for the general care of the blind upon county and county borough councils and makes the registration of all charities for the blind compulsory. In Sept. 1920, the Ministry of Health appointed a committee to investigate and report on the causes of blindness, including defective vision sufficient to impair economic efficiency, and to suggest measures which might be taken for the prevention of blindness.

In the United States statutory provision for the blind may be divided into four divisions:—

- (1) Laws affecting the education of the blind.
- (2) The action to be taken by the State in the creation of special commissions to be concerned in their general welfare.
- (3) Various forms of relief.
- (4) All other relations of the law to the blind, most of these being of an indirect character.

In most civilized countries State provision for the blind exists in a more or less adequate degree.

**Statistics.**—Dr. Harry Best has estimated that the blind pop. of the world in 1920 numbered at least 2,390,000 persons, exclusive of those blinded in the World War of 1914-8, and he gives the following ratios per million of the pop. as far as ascertainable.—Canada 449, Mexico 782, Argentina 892, Chile 800, Austria 694, Belgium 435, Denmark 527, France 706, Germany 609, Hungary 895, Ireland 982, Italy 1,175, Netherlands 463, Norway 926, Russia (European) 2,016, Sweden 663, Switzerland 722, India 1,416, Egypt, 13,251, Australia 795, New Zealand 478.

The blind pop. of England and Wales, as given by the Ministry of Health, July 1920, was 30,785, or 853 per million of the population.

**Education.**—The education of very young blind children has lately received closer attention in England by the establishment of kindergarten schools and classes—notably a model school at Birmingham, and the provision by the National Institute for the Blind of the first home in the British Empire for blind babies at Chorley Wood, Herts. This was to be followed by similar homes elsewhere. It is a fact that very few parents of blind children know how to treat them. Either they are spoiled by mistaken kindness or they are greatly neglected; in either case the result is thoroughly bad—hence the necessity of their removal to homes where they may live under the best conditions and may, in the hands of experts, receive a training suited to their disability. The percentage of blind children under the age of five who are mentally defective is very high, ranging from 33½% to 50%. They are unsuitable for schools for normal blind children, but are eligible for special schools for the blind—at St. Leonards-on-Sea at the age of three, and at Rhyll at the age of four.

A great impetus was given to the education of the blind in England by the founding of the College of Teachers of the Blind in July 1907. The objects of the college are primarily to promote and encourage the training of teachers of the blind, to improve their status and to afford them opportunities for submitting their qualifications to the scrutiny of an accredited examining body. The status, qualifications, training, remuneration and recruitment of craft teachers of the blind receive the careful attention of the college, the question of

training being the most important. Great difficulty is experienced in securing good craftsmen who are well educated and apt at imparting their knowledge to their pupils. Until better facilities are available it is suggested that the ranks may best be filled by making careful selections from among the most expert craftsmen, and then imposing the art of teaching upon their craftsmanship. The office of the college is c/o National Inst. for the Blind, 221, Gt. Portland St., W. 1.

**Employment.**—As a large percentage of blind persons had lost their sight in adult life, professional and handicraft training is necessary even up to the age of 50, after which it is rarely successful. It is generally agreed that, where practicable, blind persons should continue in the occupations which they followed before losing their sight, but where, as is usually the case, this is not feasible a selection from the occupations most suited to the blind has to be made. The following is a list of trades and occupations practised by the blind, some being suitable for the workshop, some for the home and some for either: brush-making, basket-making, mat-making, mattress-making and allied industries, cane and rush seating, boot-repairing and clog-making, carpentry and wooden-toy making, ships' fender making, netting and string-bag making, hand and machine knitting, weaving, poultry-farming, dairy work, pig-rearing, gardening, fruit-farming, news-vending, shop-keeping.

Every encouragement should be given to the employment of suitable persons in professional work; blindness obviously inflicts a lesser handicap upon the brain worker than upon the manual worker, hence the desirability of encouraging intellectual pursuits, of which the following are the most usual: Holy orders, law, politics, music, lecturing, teaching, coaching, journalism, business management, commercial travelling, organizing and secretarial work, shorthand and typewriting, insurance and other agencies, telephony, massage, and pianoforte-tuning.

Excluding professional careers it is generally agreed that the workshop provides the best means of employing the blind, as they there obtain regular employment under skilled supervision and in many cases receive a substantial weekly bonus by way of augmentation of wages. Among the large workshops in the United Kingdom the following may be mentioned:—Bradford Royal Institution for the Blind; Birmingham Royal Institution for the Blind; Bristol Residential School and Workshops for the Blind; Cardiff Institute for the Blind; Leeds Incorporated Institution for the Blind and the Deaf and Dumb; Henshaw's Institution for the Blind, Manchester; Royal Midland Institution for the Blind, Nottingham; Liverpool Workshops and Home Teaching Society for the Outdoor Blind; Royal Blind Asylum and School, Edinburgh; Royal Glasgow Asylum for the Blind; Incorporated Association for Promoting the Welfare of the Blind, Tottenham Court Rd., London.

**Systems of Reading.**—The Braille system is used throughout the world, and can be adapted to any language or dialect. English-speaking countries use the British alphabet based on the original French alphabet devised by Louis Braille. In the United States some differences were introduced, but at the time of writing it seems most probable that a system almost identical with that common to all other English-speaking countries will rapidly come into vogue.

In addition to the Braille method of producing books for the blind the system invented by the late Dr. Moon is used to a considerable extent. It is easier to learn than Braille, but has the serious disadvantages of occupying very much more space, and of not lending itself to the contractions which have been introduced into Braille, and which greatly add to the speed of reading. The Moon Society is now controlled by the National Institution for the Blind.

**Embossed Literature.**—Great progress has been made in the methods of printing and illustrating books for the blind. In 1909 the National Institute for the Blind (then known as the British and Foreign Blind Association), through its secretary-general, Henry Stainsby, instituted exhaustive inquiries as to the best and quickest methods of printing Braille, with the result that the slow, cumbersome and unsatisfactory method of printing on wet paper gave place to the introduction of dry printing on special paper by means of fast-running electrically-driven and electrically-heated presses of the platen type. This new method of printing was found to be 13 times faster than the old method.

Book illustrations which are essentially diagrammatic rather than pictorial are printed on the same presses, the plates consisting of folded sheets of zinc upon which illustrations are embossed by means of a special machine and a variety of hand punches. The embossing through folded sheets of metal produces a perfect die and counter-die, between which the paper is embossed in the press.

The fact that many scientific books are produced in Braille must be laid to the credit of Mr. H. M. Taylor, Fellow of Trinity College, Cambridge, who invented the mathematical and chemical formulae which render their use possible. Blind students in all English-speaking countries owe much to Mr. Taylor for having enabled them to read by themselves books which otherwise they could only have mastered with the help of a reader.

Many magazines for the blind, designed to suit various classes of readers, are published in the United Kingdom, the principal being *Progress*, *The Literary Journal*, *The Braille Musical Magazine*, *Comrades*, *The School Magazine*, *Nuggets*, *Hampstead Magazine*, and *Hora Jucunda*. But the magazine which has the largest circula-

tion in the *Matilda Zeigler Magazine* published by W. C. Holmes, New York, and distributed free of charge. There are two weekly newspapers for the blind in the United Kingdom—the *Braille Mail* and *Weekly Summary*.

**Music.**—The Braille music notation has recently undergone great developments at the hands of a committee of blind experts appointed by the National Institute for the Blind, under the chairmanship of its director of music, H. C. Warrilow. The old method of writing several bars for the right hand followed by a corresponding number for the left hand has given place to the practice of writing only a bar for each hand alternately. In music of a simple character both hands are written together, chord by chord. These two modes of writing are known as the "bar by bar" and "vertical score" methods respectively, and emphasize the harmonic aspect as distinguished from the melodic which characterized the old method, the parts being always written upwards from the bass. So great has been the general improvement in representing the staff notation that it is now possible to record in Braille any kind of music, no matter how elaborate.

**Lending Libraries.**—Embossed books and music, being very cumbersome, can only be stored in limited numbers in the homes of the blind, but are admirably distributed free of charge by such agencies as the National Library for the Blind, London, which possesses 65,000 volumes (representing 7,500 complete works) of general literature in the Braille and Moon types, and 11,000 pieces of music (representing 5,000 complete works).

**Apparatus.**—Various methods have been devised to supply the blind with reading-matter other than through the ordinary channels of embossed books, but none of these have so far proved very practical, though hopes are entertained that continued and patient investigation will solve many of the difficulties that now prevent their wide adoption.

**Institutions and Societies for the Blind.**—The accommodation provided for schools and workshops has been greatly improved in England either by additions to existing buildings or the erection of entirely new premises. Within the latter category may be mentioned the schools for the blind at Gorleston-on-Sea, Leatherhead, Bristol, Bradford, and the workshops at Birmingham and Hull. The extensive new buildings of the headquarters of the National Institute for the Blind were opened by the King and Queen in March 1914. This Institute has, since then, made enormous strides, its principal work being the publication of books and music, home teaching, provision of homes and hostels for the blind, care of blind babies, the relief and after-care of blind civilians, and the higher education of the blind and the financing of other societies. It is affiliated to St. Dunstan's and to the Canadian National Institute for the Blind, the last-named doing corresponding work from its headquarters in Toronto.

**Obituary.**—Among notable blind men who have died since 1910 may be mentioned the following:—

Sir Francis Joseph Campbell, LL.D. (1832-1914), the writer of the earlier article in this encyclopaedia (see 4.59\*). Born in Franklin county, Tennessee. Blinded at the age of four by the thorn of an acacia tree whilst playing. Educated at various schools for the blind, also at Harvard, Leipzig and Berlin. Was first principal and co-founder with Dr. T. R. Armitage of the Royal Normal College for the Blind, Upper Norwood, London, through which great impetus was given to the higher education of the blind, particularly in fitting sightless persons to become teachers, musicians, pianoforte-tuners, and correspondence clerks.

The Rev. H. J. R. Marston, M.A. (1853-1921). Rector of Lydford-on-Fosse. Graduated at Durham University, where he had a brilliant career, obtaining high honours and the Hellenistic Greek prize,—also a fellowship.

John Brown Herreschoff (1841-1915). The famous blind designer of the "Vigilant" and "Columbia," which so successfully defended the American Cup against the "Valkyries" of Lord Dunraven and Sir Thomas Lipton's "Shamrock."

The Rev. William Hill Murray (1841-1911). As an agent of the National Bible Society of Scotland he went to China and there became interested in the cause of the blind, and himself invented a numeral system for the blind to take the place of the intricate Chinese language.

**BIBLIOGRAPHY.**—Sir Arthur Pearson, *Victory over Blindness* (1910) and *The Conquest of Blindness* (1921); W. H. Illingworth, *The History of the Education of the Blind* (1910); Wilmfred Holt, *A Beacon for the Blind, being the Life of Henry Fawcett* (1915); Harry Best, *The Blind* (1919); Wm. Campbell Posey, *Hygiene of the Eye* (1920).

**Blinded Soldiers and Sailors.**—Special reference must be made to the British soldiers and sailors who were blinded in the World War, and who came directly under the care of the St. Dunstan's organization, which it was the writer's privilege to found and conduct. These men form an exceptional group in the blind world, but the success of the ideas adopted in their training, the high example of the men themselves, and the interest awakened by their triumph over difficulties, must have a permanent influence in raising the status of the blind even in other countries

beyond the United Kingdom. The men were exceptional, because so many of them were young and full of the vigour of health when their sight was taken from them. Drawn from all classes, differing greatly in education, experience and temperament, they were as a whole men with a keen hold on life, ready for any effort that would bring them again in touch with the everyday world of work and pleasure. Fundamental to their training was the idea that blindness was not to be regarded as setting men apart from their fellows. It was to be held in the light of a handicap; never as an affliction calling for pity. They were to rely on themselves to the utmost degree and to make it their object to be normal. In itself such a mental outlook had a far-reaching influence; on it was based the whole system of training for these blinded soldiers who, from the first, found themselves kept in touch with all ordinary interests, while the kind of work for which their training fitted them went far beyond old-fashioned ideas of occupations for the blind.

St. Dunstan's, a large house with 15 ac. of ground, bordering on Regent's Park, London, was generously placed at the disposal of the Blinded Soldiers' and Sailors' Care Committee by Mr. and Mrs. Otto Kahn, and was opened in March 1915. It became the officially recognized training centre for the British fighting men (including those of the overseas forces) who lost their sight in the war, with the exception of a comparatively small number of the Scottish soldiers who were trained at Newington House, Edinburgh. Queen Alexandra graciously consented to be patroness of the hostel. Other large houses in the neighbourhood were lent or rented; temporary buildings—including dormitories, classrooms, workshops, two chapels and recreation halls—were erected in the grounds of St. Dunstan's. On account of the difficulty of getting in touch with the blinded soldiers scattered in many hospitals the military authorities arranged for their treatment at St. Mark's, Chelsea, and the 2nd London General Hospital. In this way was avoided the danger of discharged men returning hopelessly to their homes with no other prospect than lives of vacuity. While still in the wards of the hospital they learned what blind men were able to accomplish, and began, under the tuition of visitors from St. Dunstan's, the task that lay before them of conquering blindness, a task in which few of the whole number were to fail. Nor was it to occupy any great length of time. The course of reëducation, all that is involved in learning to be blind, occupied in some cases less than a year and seldom extended to two years. Many of the men were not only blind but had been otherwise wounded; some had lost a hand, or an arm or a leg, or were sufferers from shell-shock. But even in spite of these additional difficulties rapid progress was usually made.

The accepted definition of blindness was: "Unable to read or write or to do ordinary work in any ordinary way." The vast majority of the men who came to St. Dunstan's had had their eyes destroyed or were what is known as "dark blind." The remainder were able to distinguish light, and of these a small number had some slight degree of sight. Such were the men who with almost unexampled fortitude set themselves to get back to active life.

It is well to emphasize the spirit of St. Dunstan's. The hostel was a centre of brightness, and the men were no less determined to be happy than the people about them were to help them to forget what they could not do and to make the most of all that they could do. At one time no fewer than 800 men and women were giving the whole or some part of their time to the care, entertainment and instruction of the blinded soldiers. Through the carpets in the public rooms of St. Dunstan's ran linoleum paths for the blinded men, handrails bordered the walls through the grounds, sounding-boards gave warning of steps. With these helps the men quickly developed the senses of direction and obstacle, the confidence that would enable them to find their way in their own homes without assistance and to trust themselves in public thoroughfares. Self-reliance was a constant aim; the blinded soldier learned the value of avoiding what ever might emphasize his handicap. The more normal his bearing the more were those about him put at their ease, and from every point of view was his happiness increased. In the sense of touch, of hearing and of smell he daily discovered new powers. From the impressions thus received he began to visualize, forming mental pictures of the people he met and his surroundings. The men at St. Dunstan's had not only to learn to work but to discover how

\* These figures indicate the volume and page number of the previous article.

fully their leisure hours might be occupied. Constant entertainments were given at the hostel; the men were taken to concerts and theatres; they attended football and cricket matches, with escorts to describe the games; they found much pleasure in dancing, and threw themselves into the interest of out-door sports, swimming, foot races, tugs-of-war and rowing. The St. Dunstan's crews practised on Regent's Park lake, under the direction of a coach, and annually competed against one another in regattas on the Thames; they raced, also, against sighted crews with success.

The hours devoted to instruction at St. Dunstan's were short; in teaching the newly blind it is necessary to remember the effort of intense concentration involved. Two-and-a-half hours in the morning and two hours in the afternoon were spent by the men in the classrooms and workshops. The employment of many blind instructors was an important factor in the rapid progress that was made; the blind experts gained at once the confidence of the blinded soldiers, who realized that their difficulties were understood and that nothing beyond their powers was being demanded. Among the officers and men were many already experienced in some branch of business or professional work, and when it was feasible they were encouraged to prepare themselves to resume their accustomed employment. The fact that one of the blinded officers went back to his practice as a barrister, and another renewed his work as a chartered accountant, may be recorded as examples of the manner in which difficulties were surmounted. The occupations selected as being most easily mastered by the sightless man who seeks profitable employment were eight: massage, poultry-farming, shorthand-writing (by means of a machine), telephone-operating, joinery, boot-repairing, mat-making and basketry. All of these were taught, in addition to the art of netting, which may be regarded as a remunerative form of recreation for the blind. Many of the blinded soldiers learnt two trades. All of them acquired proficiency in typewriting and received instruction in reading and writing Braille.

While the war was still in progress some 60 blinded soldiers were already employed, largely in military hospitals, as trained masseurs. They had passed stiff examinations, and it is a remarkable fact that, in spite of their own disability, they had equipped themselves to help in the cure of other wounded men. As soon as the blinded soldiers had mastered an occupation they were found employment or set up in their new industry. Apart from the pensions they received they were able to earn incomes in some cases higher than they had gained as sighted men before joining the army.

Before the close of 1920 1,300 blinded soldiers were established in different occupations in Great Britain, in Canada, South Africa, Australia and New Zealand. At that time there were still several hundred others in training or to be trained. Besides the soldiers actually blinded in the war, 23,000 were discharged from the army with seriously damaged eyesight, and from this number men arrived at St. Dunstan's overcome by the blindness which had for long threatened them.

Early in 1921 St. John's Lodge, on the Inner Circle of Regent's Park, became the permanent headquarters of St. Dunstan's work.

The generosity of the public who supported St. Dunstan's was a tribute to the high courage of the blinded soldiers; it made it possible to do everything that was required for their new start in life and to create an organization for their after-care. A high percentage of success cannot be attained in the rehabilitation of any large body of blind men by training alone. Some definite assistance is required after men have been trained, supplied with their tools and equipment and settled in their own homes. A scheme of organized assistance was first tried on a large scale by the authorities of St. Dunstan's. The first concern of the blind craftsman is his supply of raw material. This must be constant, of the right quality and nature, and must be available at a good market price. Lack of sight makes the ensuring of these essentials difficult, and St. Dunstan's organization therefore established a stores and materials department from which any blinded soldier was able to obtain in small quantities the materials necessary for his trade. Many hundreds of articles or kinds of material coming from all parts of the world were always kept in stock. All goods were supplied strictly at average cost, all expenses of buying, storing and distributing being met from St. Dunstan's funds. In order to ensure a constant market, even in times of trade depression, sales depots were established, and the men were paid by return of post the average price obtained when their goods were sold. All expenses connected with carriage and achieving the sales were paid by the organization. All articles which were sent up for sale were critically examined, and any tendency to bad or careless workmanship was quickly stopped.

A staff of experts was employed to visit the men periodically in their homes where they were able to correct mistakes and teach new types of work in local demand. An employment and propaganda department was established to obtain work for, and promote the interest of, professional men, and steps were taken to ensure that their methods of working were modern and up-to-date. In addition to the administration of the services mentioned above, a number of convalescent and holiday annexes were established throughout the country. A fund was available from which men could obtain grants in cases of sickness, accident or business difficulty. The Blinded Soldiers' Children Fund, which was raised to provide a weekly allowance until the age of 16 years to every child born to a blinded soldier after his disablement, and therefore not pensioned by the Government, was distributed by this department. The men's typewriters were kept in working order, the visitors who went to see the men at intervals being given a short course of instruction in minor repairs. Music, reading and games were encouraged among the men, and books, magazines, cards, dominoes, and music were provided when these were required. In general, St. Dunstan's After-Care Organization aimed at reducing a blind man's handicap to a minimum in order to enable him to compete with his sighted rivals on even terms.

In the preparation of this article the author gratefully acknowledges the assistance of Mr. Henry Stainsby, the secretary-general of the National Institute for the Blind, and of Capt. Ian Fraser, director of the After-Care Organization of St. Dunstan's. (A. P.)

**BLISS, CORNELIUS NEWTON** (1833-1911), American merchant and politician (*see* 4.72), died in New York Oct. 9 1911. Although prominent in the Republican party and long the treasurer of its national committee, he would never run for public office. His lack of sympathy with Theodore Roosevelt's growing influence led him to retire from active politics.

**BLISS, TASKER HOWARD** (1853- ), American soldier, was born at Lewisburg, Pa., Dec. 31 1853. He graduated from West Point in 1875, was commissioned second lieutenant, and in 1880 was promoted to first lieutenant. From 1885 to 1888 he was professor of military science at the Naval War College; then for seven years aide-de-camp to Gen. Schofield and inspector of rifle practice, with the rank of captain from 1892. In 1897 he became military attaché at the American legation in Madrid. In 1898 he became major, and on the outbreak of the Spanish-American War was promoted lieutenant-colonel, serving through the Porto Rican campaign. From 1898 to 1902 he was in charge of Cuban customs and collector for the port of Havana. In 1902 he became a member of the Army War College Board, and in the following year commandant of the Army War College. From 1903 to 1905 he was a member of the joint Army and Navy Board and also a member of the general staff. From 1905 to 1909 he held various commands in the Philippines. During the latter half of 1909 he was president of the Army War College and a member of the general staff, and then was appointed assistant chief-of-staff, becoming in 1915 chief-of-staff. In 1917 he was made commanding-general, U.S. army, but later in the year retired, having reached the age limit. He was a member of the Allied Conference (1917), of the Supreme War Council (1918), and of the International Peace Conference (1918-9).

**BLOCKADE** (*see* 4.72).—The blockade enforced against Germany by the Allies in the World War was both in form and extent without precedent in naval history, and its enforcement has given a new meaning to the word. It was not a blockade in the strict sense of the word; that is, a cordon of ships off an enemy's coast precluding all approach to it under ban of confiscation. In its final form it constituted a vast system of economic pressure for the restriction of enemy supplies, and the power of the British navy to intercept, detain and search ships and cargoes afloat remained up to 1917 an essential part of it.

The Declaration of London, under which the navy attempted at first to enforce the blockade, proved mere filigree, entirely inapplicable to the intricacies of naval war. It represented an attempt to reduce prize law to a code, and its effect was to render

the British blockade of Germany fuddle up to March 1915. Under its rules food, cotton and all conditional contraband could not be touched so long as they were discharging at neutral ports such as Rotterdam or Copenhagen. One saving clause had been added in an Order of Council of Aug. 20 1914, which permitted some latitude by rendering such cargoes liable to capture if there were sufficient evidence of enemy destination. Unfortunately even this safeguard was swept away by a British Order in Council of Oct. 29 1914 which restricted seizure of conditional contraband to goods consigned to "order" or without a named consignee, a regulation which promptly produced a vast crop of dummy neutral consignees and rendered the blockade ineffective for five months. No further action was taken against food-stuffs, and for five months a succession of ships streamed daily through the Downs, bound for Holland and Scandinavia with food and cotton for Germany. Four cargoes only were placed in prize, whereupon the prize court in London proceeded to sweep all the veneer of rules away and adjudged that a "named consignee" must be a *bona fide* and not a dummy consignee (British and Colonial Prize Cases, the "Rijn," June 6 1917).

The judgment has an important general bearing, for it constitutes a justification from the naval point of view of the established system of adjudication by a qualified court, where general principles are applied to particular cases in the light of experience and common sense, compared with a system based on a code operated by busy officials under a burdened Secretary of State.

It was not until March 11 1915 that the blockade was tightened up by a new British Order in Council, under which all goods with enemy destination or of enemy origin became liable to seizure, and it was not till July 7 1916 that the broken shards of the discredited Declaration of London were finally swept out of the way. It was not a code but machinery that was wanted, and by March 1915 the machinery was beginning to take shape. The part played by the British navy consisted in the interception and examination of ships, which was under the purview of the Trade Division (Capt. Richard Webb) of the Admiralty. A British Contraband Committee, with representatives of the Admiralty (Capt. Horace Longden and Lt.-Comm. W. E. A. Arnold Forster), Foreign Office and Board of Trade, had been set up in 1914 to decide whether a ship or cargo was to be sent in for adjudication. Its necessary adjunct, a War Trade Intelligence Department to collect and collate information of ships and cargo, was established somewhat later. The code disappeared, and each cargo was dealt with on its merits.

The British naval work directly associated with the blockade fell under two heads—the work of the blockade squadrons at sea and the service of naval control. It was the function of the blockade squadrons to patrol the avenues to the ocean, intercept neutral craft and send them into port for examination. This was the task of the 10th Cruiser Squadron, one of the hardest tasks of the war and one which has received perhaps too scanty a meed of praise. The squadron consisted at first of Edgar class cruisers, but being unable to stand the terrific seas of the North Atlantic they were withdrawn and their place taken by large armed merchant cruisers (18 in number, in Nov. 1914) under the command of Rear-Adml. Dudley de Chair (succeeded in 1916 by Vice-Adml. Sir Reginald Tupper). In the South the conditions were different. The configuration of the coast, the fear of minefields and destroyer patrols off Dover resulted in all traffic being shepherded willy-nilly into the Downs; and this practically dispensed with the difficult task of interception. The practice of performing the search of ships in harbour was an innovation, and it remains one of the outstanding lessons of the war that "visit and search" (if the search involves an effective examination of the cargo) cannot be effectively performed at sea, partly on account of the complexity and difficulty of the work under modern conditions, partly on account of the danger of submarine attack. Ships were accordingly sent into harbour to be searched, and though the dispatch of neutral ships into harbour was undoubtedly a considerable extension of the universally recognized right of visit and search, it was an extension inherent in the circumstances, for without it the search would have become ineffective and the

right null and void. The practice, however, involved some nice legal points, such, for instance, as whether a ship sent into a harbour by *force majeure* to be subjected to visit and search comes under the full force of municipal jurisdiction and of port regulations which would have subjected a huge Norwegian liner to quarantine for a case of smallpox on board.

The patrol lines of the 10th Cruiser Squadron stretched at first from Norway to the Shetlands (230 m.), but as the submarine menace extended they were moved to the westward and lay sometimes between Iceland and the Hebrides, sometimes between the Shetlands and Faroes (160 m.), and the Faroes to Iceland (160 m.) The average weekly number of ships intercepted in 1915 was about 66, of which some 15 to 20 were sent weekly into Kirkwall with an armed guard. It was the duty of the officer of the armed guard merely to ensure that the ship was steering a proper course, and he did not interfere in any way with the ordinary navigation or administration of the ship.

Little has been written of the work of the 10th C. S., but its dangerous nature can be gathered from the number of its ships lost by mine and submarine. In 1915 its losses amounted to four. The "Viknor" (Comm. E. O. Ballantyne) was lost with all hands, off the coast of Ireland (Jan. 13), probably on a mine; the "Clan Macnaughton" was supposed to have foundered (Feb. 3); the "Bayano" was sunk by U27 on March 11 off Galloway; the "India" by U22 off the coast of Norway on Aug. 20. The "Alcantara" (Capt. Thos. E. Wardle), which sank the raider "Greif" on Feb. 29 1916, belonged too to this squadron, whose name was a household word in the blockade. The institution of the white-list and black-list, which gave an indication of a ship's nature, and the issue of green clearances to neutral ships sailing from British ports, facilitated the work of interception; and by March 1915 nearly all the more important neutral lines had agreed to call at Kirkwall or the Downs in order to avoid the delay of being intercepted far out at sea and losing time in putting back.

In 1915 the number of vessels intercepted by the 10th C. S. was 3,098, of which 743, or 24%, were sent into Kirkwall; the remainder, including 817 fishing vessels and 408 British and Allied ships, were allowed to pass. During the same year 19 ships succeeded in evading the patrols, of which only eight were of real consequence, a comparatively small number in view of the long northern nights full of wind and frost and snow.

The port of control and detention in the North was Kirkwall, which provided a large enclosed harbour where ships could be safe from the sea and the enemy. The average number of ships calling and sent in was some two or three a day in 1915, but in the latter part of 1916, when Dutch traffic began to go north for a time, it rose to five or six.

The Downs (Comm. W. Moorsom and Capt. Walter Tomlin) was far the largest control station, and had the really immense task of dealing with three-quarters of the neutral trade of northern Europe. All the Channel traffic up and down had to be shepherded through, and here some 10 to 15 neutral ships had to be examined daily. The manifest was taken off, sent ashore, summarized (no light task in the case of big Dutch East Indies cargo ships) and telegraphed to the Contraband Committee. The ship outside the hold was searched for contraband and German mailbags, and some of the items in the hold were examined and compared with the manifest. To examine and search a large liner and the luggage of some 500 passengers took 10 officers and 20 picked men the best part of 18 hours. German women were searched by lady searchers and allowed to go on. Meanwhile the manifest was examined by the Contraband Committee in the light of the knowledge they had of ships, cargoes, consignors and consignees, and instructions sent to clear the ship or to send her in to discharge all or a portion of her cargo, or to detain her till guarantees were received. The ordinary period of detention for ships eastward bound was one to three days, for ships westward bound a day or less. A smaller control station at Falmouth relieved the Downs of a portion of its burden.

The power of naval interception, visit and search, was in itself a powerful form of pressure, for neutral shipping companies in

order to avoid delay preferred to send lots of their cargo in advance and to make reciprocal arrangements for rapid clearance. It was, however, only a single weapon in the armoury of economic pressure. Control of bunker coal, shipping insurance, censorship and cables, all found their place there, and formed the basis of agreements with large corporations of merchants formed for the purpose, such as the Netherlands Oversea Trust (N.O.T.) for Holland, the Danish Merchants Guild for Denmark, the Société Suisse de Surveillance Economique (S.S.S.) for Switzerland. Sweden took a different line and made all such agreements illegal, maintaining this attitude till April 1917. She was beyond the reach of British sea power, and the Lulea iron-ore trade, though attacked with considerable effect by British submarines in 1915-6, remained the principal stay of the German munition industry.

The fundamental problem of a blockade of this type is to discriminate between enemy and neutral destination, and the two principal systems of discrimination may be termed the "Intelligence" or "evidential" system and the "Rationing" or statistical system. In the first, particular cargoes or items in a cargo become suspect if there is any evidence of enemy dealings. In the second, the whole mass of importation becomes suspect immediately it rises above the normal average of imports. The blockade emphasized the weakness of the former system, which required enormous labour and specialized knowledge to keep track of possible enemy dealings, and as early as Jan. 1915 the "Rationing" or statistical system was being advocated, and it was proposed that careful account should be kept of the imports of all important commodities, and when the import figures to any neutral country rose high above the average for no accountable cause, a plea for confiscation should arise. To keep these statistics, which were largely based on the manifests, the War Trade Statistical Department in London came into being, and in 1916 the principle of rationing was adopted by the Minister of Blockade as the fundamental tenet of his system. But here a difficulty arose which was never completely solved. Legal sanction for condemnation was difficult to obtain on the basis of figures alone, for statistics supplied no direct evidence of enemy destination and the system had to be largely operated by means of assurances and agreements. But, in spite of difficulties, by the middle of 1916 the blockade was becoming really effective. It began with an excellent (but specious) code and no machinery; it ended with excellent machinery and no code.

There can be no question that the World War has greatly modified our conceptions of blockade. One of its most important lessons is that discrimination between belligerent and neutral destination is possible and can be enforced without friction, if only the principle be admitted that a belligerent who controls the sea is entitled to ask for evidence or assurance of genuine neutral trade. Mercantile coöperation can then be invoked with official approval to supply the machinery for such assurance. This does not mean the legal prohibition of contraband trade, but it means that such trade would gravitate into particular ships which would have to run the blockade. As the sphere of agreements and economic action extended, the rôle of the fleet diminished, though there still remained certain sections of trade either immune from attack or which could be reached only by the fleet. Examples of such sections of trade were the German iron-ore trade with Lulea in the Baltic Sea, and the iron-ore trade with Narvik in Norway. A score or so of German ships were engaged in the latter, passing down the Norwegian coast inside Norwegian waters, but there were two areas, one off Statlandet and the other off Ekersund, where they had to leave neutral waters, and these were periodically visited, though not permanently patrolled. Ships were also constantly passing from Rotterdam to Germany, and it was not till 1917 that determined efforts were made to stop this trade.

In 1917, when the United States came into the war, the blockade underwent a great change. The Allied Powers in conjunction with the United States now possessed an almost complete control of many of the principal commodities, and the combined pressure they exerted was so tremendous that the goods never

got as far as the sea, and the blockade was practically transformed into an embargo.

The final cutting edge of the blockade in 1917 and 1918 was enforced not at sea but on the custom house quays at Boston, Liverpool and New York. The ships of the 10th C. S. left their stormy beats to do convoy work. The Downs and Kirkwall languished, and the control services were transferred to Halifax, Jamaica and Sierra Leone.

The fact that many forms of economic pressure contributed to the blockade must not blind us to the fact that they were to a large extent aspects of sea power. Thus, bunker control, a powerful lever of the blockade, was enforced by the British Customs and Board of Trade, but the British coaling bases abroad had been won by sea power and remained dependent on sea power. Where the arm of the British navy could not stretch the blockade broke down. The frontiers of Rumania were impervious to it and enabled Germany to hold out during 1917. To the last the Lulea iron-ore trade remained a menace, for sea power could not reach so far. In its bulk the blockade remained an expression of sea power, with the imminence of the Grand Fleet going and coming ceaselessly behind it in the North Sea. (A. C. D.)

**BLOEMFONTEIN** (see 4.74).—Pop. (1918): whites 15,631; coloured (estimated) 16,000. The most centrally situated town in South Africa, Bloemfontein is the great market for the agricultural and pastoral produce of the Free State. The annual sale of pure-bred stud stock, held in Sept., is the principal fixture of the kind in South Africa; in 1920 the pedigree stock sold realized £283,000. The growth of the town during 1910-20 was largely due to the progressive policy of the municipality, which provided it with an ample supply of water, electric light, an electric trackless tramway system, modern sewerage system and other public services. In 1918 the rateable value of the municipality was £3,895,000, its revenue £182,000 and its indebtedness £803,000.

Among modern buildings are the new Law Courts (in the classical style), the National museum, the Normal and Polytechnic Colleges, Grey University College, the Government Buildings (which replace those burned down in 1908) and the Legislative Council Chambers (the seat of the Appellate Court). A monument to the women and children who died in concentration camps during the war of 1899-1902 was erected in 1913 near the Show ground. The principal workshops of the Union railways are situated in the town of Bloemfontein.

Grey College, incorporated as a university college in 1910, has been since 1918 the principal constituent college of the university of South Africa. Besides the university college the institution includes high schools for boys and girls, and the buildings stand in grounds covering 300 acres. At Glen, 14 m. N., is an agricultural college, opened in 1919, with an experimental farm of 4,000 acres. There is a military station at Tempe, 4 m. from the centre of the town, and here is the Defense College for Officers.

Its central position makes Bloemfontein a favourite meeting-place for conventions and congresses, educational, agricultural and political. Here was held, in the autumn of 1920, the conference which sought, and failed, to find a basis for *reconciling* (union) between the two great Dutch parties in the Union, the South African and the Nationalist.

**BLOMFIELD, SIR REGINALD** (1856- ), English architect and author, was born Dec. 20 1856 at Aldington in Kent, of which parish his father was rector. He was educated at Haileybury and at Oxford as a scholar of Exeter College. He took his degree with a first class in literae humaniores in 1879. On leaving Oxford he was for three years in the architectural office of his uncle, Sir Arthur Blomfield, and also studied in the Royal Academy School of Architecture. He was here largely influenced by Norman Shaw, to whose work and example, as also to those of Philip Webb, his own work owed much. After travelling abroad in 1883, he started a practice in London in 1884. He became one of the secretaries of the Art Workers Guild, and also of the Arts and Crafts Society. The Gothic and Mediaeval tradition of his uncle's office had but little effect on his work as an architect, which rather follows the classical spirit and the inspiration derived from the later Renaissance architecture of England. This is shown notably in his country-houses, amongst which are Moundmere, Basingstoke; Wyphurst, Cranleigh; and Uretham Hall, Norfolk. He also carried out

alterations to existing houses at Brocklesby Park, Lincs.; Ape-  
thorpe, Northants.; Chequers Court, Bucks. and elsewhere.  
Amongst his London work are the United University Club, Pall  
Mall; the Goldsmiths' College, New Cross; the London and  
County Bank; the Imperial War Cross, Chelsea; and Paul's  
Cross, St. Paul's Churchyard. At Oxford he built the new  
buildings for Lady Margaret Hall, and at Bath the Holbourne  
Museum. With Sir Aston Webb and Ernest Newton he was  
appointed to advise as to the architectural treatment of the  
Quadrant, Regent Street, London, and he designed a portion  
of the façade.

As author, Sir R. Blomfield is known by various important  
volumes of history and criticism. His Academy School Lectures  
were published in 1906 as *The Mistress Art*. His *Formal Gardens  
in England* (1892), published in collaboration with F. Inigo  
Thomas, did much to make known the claim of the architect to  
consider as his right not only the design of the building but of  
the surroundings in which it was set. His *History of Renaissance  
Architecture in England* (1897) and his successive works on  
*French Architecture* (1911 and 1921) are accepted by students as  
textbooks, and their illustrations show the author's considerable  
powers as a black-and-white artist.

Sir R. Blomfield was elected A.R.A. in 1905, and R.A. in  
1914, in which latter year he was also made Officier de l'Instruc-  
tion publique by the French Government. He was professor of  
architecture at the Royal Academy from 1906 to 1910. He was  
elected president of the R.I.B.A. in 1914, and received its Gold  
Medal in 1913.

As an old member of the Inns of Court volunteers, at the  
commencement of the World War he received a commission as  
officer in charge of trench work. At its termination he was  
appointed a principal architect of the Imperial War Graves  
Commission, and he was one of the chief designers of various  
forms of local war memorial. In 1906 he was made hon.  
fellow of his college, and in 1920 Liverpool University con-  
ferred on him the hon. degree of Litt.D. He was knighted in  
1919 in recognition of his work as architect and author.

**BLUE SKY LAWS.**—This name is popularly applied in the  
United States to those statutes enacted in many states to  
protect from fraud purchasers of stocks and bonds. The first  
Blue Sky law was passed in Kansas in 1911, requiring invest-  
ment companies among other things to file with the Secretary of  
State a full description of their business and forbidding them  
to sell securities until authorized by the bank commissioner.  
Following the Kansas model, within two years no fewer than 18  
other states had enacted similar legislation, and by the close of  
1919 some form of Blue Sky law was to be found in 44 states.  
Requirements vary in the different states, but in every case  
information must be filed with a designated official or com-  
missioner and licence obtained. In 1914 there developed con-  
siderable opposition to such legislation. Its constitutionality  
was attacked on the ground that it violated the commerce clause  
of the Federal Constitution; that it delegated legislative and  
judicial power to an executive official; that it deprived citizens  
of liberty and property without due process of law. In three  
states, Michigan, Iowa and Ohio, these contentions were  
upheld by the lower courts; but in 1917 the U.S. Supreme  
Court decided that such laws were constitutional on the  
ground that "prevention of deception is within the compe-  
tency of government."

**BLUNT, WILFRID SCAWEN** (1840— ), English writer (see  
4-93), published a complete edition of his poetical works in 1914  
and two volumes of *My Diaries* (1919 and 1920). His wife,  
Lady Anne Blunt, became Baroness Wentworth on the death  
of her niece, the daughter of the 13th Baron and 2nd Earl of  
Lovelace, in 1917. She completed a *History of the Arabian  
Horse* just before her death in Egypt Dec. 25 1917. She was  
succeeded in the title by her daughter Judith Anne Doro-  
thea, wife of Neville Stephen Lytton (b. 1879), 4th son of the  
1st Earl of Lytton.

**BODINGTON, SIR NATHAN** (1848-1911), vice-chancellor of  
Leeds University, was born at Aston May 29 1848. A gradu-

ate of Wadham College, Oxford, he became a fellow of Oriel, and  
in 1882 professor of Greek and principal of Yorkshire College,  
Leeds. It was owing to his efforts that the college was endowed  
and chartered in 1903 as a university. He died at Leeds  
May 12 1911.

**BOEHM VON BAWERK, EUGEN** (1851-1914), Austrian econo-  
mist and statesman (see 4-112), died in 1914.

**BÖHM-ERMOLL, EDUARD, FRIEDRICH VON** (1856— ),  
Austro-Hungarian field-marshal, was born in 1856 at Ancona,  
then an Austrian garrison town. He entered the army, serving  
in the cavalry and on the general staff. In the World War he  
commanded the 2nd Army, fighting first in Serbia, then against  
the Russians in Galicia and Poland. In the operation of the  
pursuit of the enemy after the battle of Gorlice he captured  
the Galician capital, Lemberg, on June 22 1915. He also  
played a distinguished part in the summer offensive of 1917.  
After the conclusion of the peace of Brest-Litovsk he marched  
into the Ukraine, and directed from Odessa the measures for  
turning to account the resources of that country. In numerous  
battles Böhm-Ermoll showed his capacity as a general in the  
field, and was highly appreciated by the Germans.

**BOISBAUDRAN, PAUL EMILE FRANÇOIS LECOQ DE** (1838-  
1912), French chemist, was born at Cognac in 1838. He was  
the discoverer of gallium in 1875 and a student of spectroscopies  
generally, on which he wrote several treatises. Some details as to  
his work appear in 5-761; 6-46; 8-208; 11-421, 777. He died  
in Paris May 31 1912.

**BOITO, ARRIGO** (1842-1918), Italian poet (see 4-155), died  
June 10 1918.

**BOLDREWOOD, ROLF**, the pen name of Thomas Alexander  
Browne (1826-1913), Anglo-Australian novelist, was born in  
London Aug. 6 1826 and was educated at Sydney College,  
N.S.W. He had an adventurous early life in Australia, being  
successively a sheep farmer, a pioneer squatter in Victoria  
and police magistrate and warden of goldfields till 1895. These  
varied colonial experiences furnished him with material for his  
long series of bushranger novels, of which *Robbery under Arms*  
is the most widely known. This book was published in 1888 in  
London after it had run as a serial in the *Sydney Mail*.  
Amongst his other books are *The Miner's Right* (1890); *A  
Modern Buccaneer* (1894); *The Babe in the Bush* (1900) and  
*A Tale of the Golden West* (1906). He died at South Yarra,  
Melbourne, March 11 1915.

**BOLIVIA** (see 4-166).—No census had been taken up to 1921  
since the rough enumeration of 1900 indicating 1,816,271  
inhabitants. In 1910 a Bolivian publicist estimated the pop. at  
1,744,568. An official estimate in 1920 set the pop. at 2,500,000.  
The inhabitants are scattered through eight departments and  
three "national colonial territories," the most densely popu-  
lated region being the department of La Paz. The pop. of the  
city of La Paz in 1920 was estimated at 107,252.

**Government.**—The fundamental law of Bolivia was in 1921  
still the constitution adopted in 1880. In 1910 some changes  
were made in the official nomenclature of towns and cities; and  
in 1914 a law was promulgated which abolished *vice-cantons*.  
Although—according to the statutes—Sucre is still the capital  
of Bolivia and remains the seat of her Supreme Court, the seat of  
government is the city of La Paz, where the National Congress  
assembles regularly, the members of the Cabinet have their  
bureaus, and where the president of the republic lives.

**Communications.**—In accordance with the Treaty of Petropolis,  
(1903), the Brazilian Government began in Aug. 1907 to construct  
a railway round the series of cataracts in the Madeira and Mamoré  
rivers, from São Antonio on the Madeira river to Guajara Merim  
on the Mamoré river (Brazil). The Madeira-Mamoré railroad was  
formally opened to traffic on July 15 1912. Bolivia then under-  
took to build a line between the Bolivian towns of Guajara Mé-  
rim and Riberalta on the Beni river, in order to link her rubber-  
producing region with Amazonian navigation. In accordance with  
Bolivia's treaty of 1904 with Chile, that Government constructed  
a railway from Arica to La Paz, which was completed May 13  
1913. Thus Bolivia was furnished with a direct route to the Pacific.  
An electric railway, financed by New York capitalists, was being  
constructed in 1921 from La Paz to Cochico in the Yungaa region.



and is to be extended to Puerto Pando. The Antoagasta and Oruro railway now reaches La Paz by its own tracks. A branch line has been constructed from Rio Mulato to Potosí. In Nov. 1916 the Bolivian Government began the construction of a difficult spur from Potosí to Sacré. Another branch from Oruro to Cochabamba was inaugurated in July 1917. A most important road was being constructed in 1921 between Uyuni and Tupiza near the Argentine frontier; trains were running between Uyuni and Atocha, while automobile service had been established between Atocha and La Quiaca (Argentina). Many miles of new telegraph lines have been built. Between July 1912 and Oct. 1916 the Marconi Telegraph Co. erected wireless stations at several points in Bolivia. On Oct. 20 1916 the first wireless message from La Paz was received in Lima.

**Commerce.**—Official figures show that in 1908 the total imports of Bolivia amounted to 40,807,856 bolivianos (see below under *Money and Banking*), while her exports came to 48,925,616. In 1915 the imports were 22,574,566 bolivianos; the exports 95,210,350. The countries taking the largest amounts of the exports were, in order: Great Britain, the United States, Argentina, France and Chile, while the countries furnishing the largest amounts of the imports were the United States, Peru, Great Britain, Chile and Argentina. The imports for 1918 amounted to 34,999,886 bolivianos, while the exports came to 182,612,850. This was an increase over the preceding year in imports of 1,519,055 bolivianos and in exports of 24,864,796. The chief articles imported into Bolivia in 1918 were valued as follows, in bolivianos: food products and beverages, 8,957,367; manufactured articles, 16,229,072; raw and slightly wrought materials, 7,022,630; live animals, 2,040,632. The most important articles of export were tin, 129,611,139 bolivianos, rubber, 11,038,042, wolfram, 10,591,429, and silver, 7,491,421. As contrasted with 1915 the figures for 1918 show that the United States had increased her imports from Bolivia about 200%, while Great Britain had increased hers about 37%; the figures for 1918 also show that the value of the imports of Bolivia from Great Britain had increased slightly, while imports from the United States had grown more than 137%.

**Army.**—The Bolivian soldiery is composed of the regular army and the reserves. Ordinarily the number of soldiers belonging to the regular army is fixed by Congress each year; in 1914 it was placed at 4,600 men. All male citizens between 19 and 49 years of age are compelled to serve in the regular army or in the reserves. The reserves in 1914 were estimated at 187,178 men.

**Education.**—A Bolivian sociologist declared in 1910 that less than 1% of his fellow-countrymen could read. Primary instruction is still managed by towns and cities. Considerable attention has recently been paid to the establishment of rural schools, as well as to the instruction of aborigines in the Spanish language. According to a report of the Secretary of Public Instruction, there were in 1916 about 450 primary schools in the Republic. In 1919 some 60,000 pupils were attending primary, secondary and normal schools. Secondary education is mainly carried on in *colegios nacionales* or in private academies. Methodists from the United States have founded an "American Institute" at La Paz, and also at Cochabamba: these academies are probably the best secondary schools in Bolivia. Bolivian teachers are mostly trained at four normal schools, the more important of these being at La Paz and Sacré. Higher education in Bolivia is peculiarly organized; for in addition to ecclesiastical seminaries, each department has at its capital an institution which is styled a university. Certain of these institutions have few university students: their instruction is mainly secondary. The university of La Paz furnishes instruction in law, medicine and theology.

**Finances.**—Early in 1908 Bolivia had only a small internal debt composed of bonds of various sorts. In Dec. of that year the Republic negotiated a loan with J. P. Morgan & Co. of New York amounting to £500,000. Subsequently three loans were floated in France to secure funds to promote banking enterprises; and another loan was raised in the United States for the construction of the railway from Tupiza to La Quiaca. Bolivia's proposed budget for 1919 estimated the revenue at 39,089,000 bolivianos, and the expenditure at the same amount. Proposed expenditures by departments were as follows in bolivianos: Treasury, 14,600,000; War, 6,300,000; Interior and Public Improvements, 5,500,000; Public Instruction, 3,100,000; Justice, 1,870,000; Worship, 58,000; and other expenditures, 7,661,000. On June 30 1919 the total foreign debt was \$3,114,682. The internal debt was composed of bonds aggregating 19,456,165 bolivianos, and a floating debt of 10,477,471 bolivianos.

**Money and Banking.**—By a law of Dec. 31 1908 Bolivia virtually adopted the gold standard. Her monetary unit is the boliviano, which when at par is the equivalent of \$0.389, U.S. currency. Both the English £ and the Peruvian *libra* (pound) are legal tender and ordinarily circulate at the equivalent of 12-50 bolivianos. A considerable amount of paper money is in circulation. Silver coins of 50 and 20 centavos circulate, as well as nickel and copper coins of smaller value. In 1919 the *Anuario Estadístico* listed the banks of Bolivia with capital in bolivianos as follows: the *Banco Nacional de Bolivia*, 9,000,000; the *Banco de la Nación Boliviana*, 1,000,000; the *Banco Mercantil*, 10,000,000; the *Banco Francisco Argandoña*, 4,000,000; the *Credito Hipotecario de*

*Bolivia*, 750,000; the *Banco Garantizador de Valores*, 100,000; and the *Banco Hipotecario Nacional*, 100,000.

**History.**—On Aug. 6 1909, President Montes was succeeded by Elidoro Villazón. Under him much economic progress took place: foreign commerce and national revenues increased, and railway and telegraph lines were constructed. Gen. Ismael Montes was again inaugurated president on Aug. 6 1913. During his new administration Bolivia felt the effects of the World War; there was a marked decline in her imports. Increased attention was paid to the mining of copper, tin and wolfram. José N. Gutiérrez Guerra, a Liberal who had served as Secretary of Finance under Montes, was inaugurated president in Aug. 1917. Shortly afterwards the agitation for an outlet to the Pacific reached an acute stage. In July 1920, because of intense opposition to his policy which apparently aimed at a *rapprochement* with Chile, Guerra was forced to resign, and was escorted out of Bolivia by way of Arica. Early in the following year Bautista Saavedra, a Republican, was elected president. He was inaugurated Jan. 29 1921.

According to a treaty with Peru, Sept. 17 1909, a survey of the Bolivian-Peruvian boundary was begun by a mixed commission in June 1910. By 1915 the commission had virtually completed the demarcation of limits, and wooden posts had been set up to mark the boundary. In the following year the two governments agreed to replace those posts by pillars of iron. Commissioners, appointed in accordance with the Treaty of Petropolis (1903), to survey the boundary line between Bolivia and Brazil, had by 1920 practically completed the task of demarcation. According to the protocol between Bolivia and Argentina dated Sept. 15 1911, surveys of the Bolivian-Argentine boundary line, which had been suspended since Oct. 1902, were resumed in 1913, and a joint commission placed iron stakes along parts of the line. A treaty signed at Asunción on April 5 1913 between Bolivia and Paraguay provided that their boundary dispute should be adjusted by direct negotiations. Commissioners of the parties soon undertook negotiations, documents were submitted in support of the respective claims, but no definitive decision had been reached in May 1921. Bolivia asserts a claim to territory on the right bank of the river, Paraguay from the mouth of the Pilcomayo river at least as far as lat. 22° S.

Early in the World War, Bolivia showed her sympathy with the cause of the Allies. Some young Bolivians proceeded to Europe and enlisted under the French flag. In Feb. 1917 Bolivia issued an invitation to the American nations asking them to unite in a declaration that submarine attacks upon neutral merchant vessels were contrary to all law. On April 13 1917 her Secretary of Foreign Relations gave the German envoy at La Paz his passports, declaring that, as a steamship navigating neutral waters with the Bolivian minister to Berlin on board had been torpedoed by a German submarine, the Government of Bolivia could no longer maintain diplomatic relations with the Imperial Government. Bolivia was represented at the Versailles Peace Conference, and on June 28 1919 her representative signed the Treaty of Peace with Germany. The Bolivian Government ratified the treaty on Nov. 16 1919. As a signatory of that treaty Bolivia became an original member of the League of Nations.

The question of an outlet to the Pacific raised by the territorial cessions of Bolivia to Chile as the result of the "War of the Pacific," was in 1921 a crucial international problem. The policy of Bolivia under various presidents had been to secure the sovereignty over territory containing an outlet to the Pacific Ocean. At times she had wished to secure the return from Chile of her former department upon the Pacific; at other times by negotiations with Chile she had aimed to acquire at least a portion of the former provinces of Tacna and Arica. Ex-President Montes, who was dispatched to France as Minister of Bolivia by President Gutiérrez Guerra, presented to the Peace Conference a plea that his country should be given an outlet through Tacna. Evidently the new Bolivian régime was

in 1901 in harmony with the Peruvian Government with regard to the question. Bolivia's aspirations had apparently again turned toward the "revindication" of Antofagasta.

**BIBLIOGRAPHY.**—*Anuario de Leyes, Resoluciones y Disposiciones Supremas (República de Bolivia)* (1911); *Anuario Nacional Estadístico y Geográfico de Bolivia* (1917-9); *Boletín de la Oficina Nacional de Estadística* (1910-5); *Comercio Especial de Bolivia, Exportación, Importación, Bancos, 1915-1916*; E. Díaz de Medina, *Bolivia, Breve Resumen Histórico, Físico y Político* (1914); *Informe y Anexos del Ministerio de Instrucción Pública y Agrícola* (1916-9); *Memoria presentada al Congreso Ordinario . . . al Ministerio de Relaciones Exteriores y Culto* (1910-9); *Ministerio de Hacienda, Memoria presentada á la Legislatura* (1911-9); *Mensaje del Presidente Constitucional de la República al Congreso* (1910-9); *Monthly Bulletin of the International Bureau of the American Republics* (1910-21); Pan-American Union, *Bolivia, General Descriptive Data* (1909-20); P. Walle, *Bolivia: Its People and Its Resources*, etc. (1914). (W. S. Ro.)

**BOLO, PAUL** (d. 1918), French financial agent and traitor, was born at Réunion, of humble parentage. He became at an early age a dentist in Marseilles, and afterwards appears for many years to have lived by his wits. In 1905 he made a bigamous marriage with the rich widow of a Bordeaux wine merchant. He entertained lavishly in Paris and Biarritz, and was received by many influential people, in spite of the fact that he underwent a term of imprisonment for fraud in connexion with one of his financial transactions. In 1914 Bolo met in Paris Abbas Hilmi, Khedive of Egypt, to whom he proposed various financial schemes, and the Khedive bestowed upon him the title of Pasha. On the outbreak of the World War Bolo appears to have entered into communication with German agents for the purpose of supporting a "defeatist" movement in certain Paris newspapers. In 1915-6 he travelled in the United States, and received considerable sums, amounting to over £300,000, from representatives of Count Bernstorff, at the time German ambassador to Washington. During 1917, however, the French Government under M. Clemenceau displayed much energy in hunting down treasonable conspiracies, and in Sept. 1917 Bolo was arrested. His trial by court-martial, begun on Feb. 4 1918, ended in his being found guilty of treason. Attempts were made to connect M. Caillaux with Bolo's proceedings, and Caillaux's acquaintance with the adventurer was brought up later to his discredit at his own trial in 1920. A sensational feature of Bolo's trial was the appearance of Monsignor Bolo, brother of the accused and a well-known preacher in Paris, as a witness for the defense, though as he had hardly seen his brother for thirty years, his evidence was of small value. Bolo was sentenced to death and shot at Vincennes, April 17 1918.

**BOLSHEVISM**, the name given since the Russian revolution to the form of Communism adopted under the Soviet system of government. Bolshevism as a doctrine and an organization is not of purely Russian growth; it is a branch of European Communism. The development of the latter is discussed in the article COMMUNISM. The earliest and most powerful expression of modern Communism is to be found in the Communist Manifesto drawn up by K. Marx and F. Engels in 1847. This Manifesto has remained a kind of gospel for extreme Communists, and its pronouncements served as a guidance in the attempt of the Russian Bolsheviks (Russian for "Majority" party) to create a Communist republic in Russia. Another element in the circle of ideas appropriated by the Bolsheviks was provided by the activity of Bakunin, the indefatigable Russian anarchist, who fought for world revolution in 1849 in Dresden and in 1870 in Lyons, and who passed 12 years of his life in prison and in exile. He was an admirer of Marx's learning and analytical power, but he would never submit to the tyrannical pedantry of Marx's school and stood up for an elemental awaking of revolutionary instincts. State and law were enemies to be fought and overthrown without any regard for tradition or practical considerations. A third element was introduced by the rise of militant syndicalism in France (see SYNDICALISM). These three currents combined to produce the three fundamental ideas of Bolshevism: the conquest of society by the proletariat

class, the power of revolutionary instinct and the dictatorship of a compact minority.

The combination proved admirably adapted in Russia for the practical purpose of the overthrow of the previously existing order. Theoretically it was a compound of contradictory elements. This was clearly discerned and exposed by a leading Marxist writer, Kautsky. He said in his book on the *Dictatorship of the Proletariat*:—

"The Socialist party which governs Russia to-day gained power in fighting against other Socialist parties, and exercises its authority while excluding other Socialist parties from the executive.

"The antagonism of the two Socialist movements is not based on small personal jealousies: it is the clashing of two fundamentally distinct methods, that of democracy and that of dictatorship."

"For us, therefore, Socialism without democracy is unthinkable."

Kautsky had no difficulty in showing that, in consequence of this fundamental flaw, the practical results of Soviet rule were deplorable. It was obliged to work by means of an unwieldy bureaucracy:—

"The absolute rule of bureaucracy leads to its ossification, to arbitrariness and stultification. The forcible suppression of all opposition is its guiding principle. How can a dictatorship remain at the helm against the will of the majority of the people?"

"In circumstances where the majority of the population mistrust the proletarian party, or stand aloof from it, this attitude would be shared by the bulk of the intellectuals. In that case, a victorious party would not only be without great intellectual superiority to the rest of the people, but would even be inferior to its opponents in this regard, although its outlook in general social matters might be a much higher one.

"The method of Paraguay is therefore not practicable in Europe. There remains to be considered the method adopted by Napoleon the First on Brumaire 18 1799, and his nephew, the third Napoleon, on Dec. 2 1852. This consists in governing by the aid of the superiority of a centralized organization to the unorganized masses of the people, and the superiority of military power, arising from the fact that the armed force of the Government is opposed to a people who are defenseless or tired of the armed struggle.

"Can a Socialist system of production be built up on this foundation? This means the organization of production by society, and requires economic self-government throughout the whole mass of the people. State organization of production by a bureaucracy, or by the dictatorship of a single section of the people, does not mean Socialism. Socialism presupposes that broad masses of the people have been accustomed to organization, that numerous economic and political organizations exist, and can develop in perfect freedom. The Socialist organization of Labour is not an affair of barracks."

No wonder that Lenin and Trotsky were highly incensed by Kautsky's criticism. They excommunicated him as a traitor to the cause, along with other Socialist leaders. But it was significant that they had to adopt the badge of "Communism" in order to mark their precise position in the field of rival doctrines. They had ceased to be Socialists in the accepted sense of the term.

The course taken by Bolshevik rule in Russia is narrated in the article RUSSIA.

**BOMBTHROWERS.**—When, contrary to all expectation, and therefore to all ideas that had governed war preparations, the World War, instead of reaching its decision in the open field, came to the deadlock of trench warfare, there arose a demand for short-range engines which could throw bombs to a greater distance than was possible by hand, or, alternatively, could throw heavier bombs to the same distance.

Eventually this need was met by the development of trench mortars and trench guns, many types of which were loosely called bombthrowers, but all of which are differentiated from bombthrowers in the sense here meant by the fact that they used an explosive propellant. These are dealt with under TRENCH ORDNANCE. But in the first phases of trench warfare such ordnance either did not exist at all or existed only in such small numbers and in so imperfect a form, that for the needs of day-by-day trench warfare along the front temporary substitutes were evolved. To these substitutes the name "Bombthrower" is—so far as army usage is concerned—restricted.

They relied for their propulsive effort, like ancient and mediaeval engines, on the energy of springs. In some cases the spring was a system of powerful rubber pieces put in tension when the weapon was cocked and suddenly released by the pulling of a

trigger. In one case the source of power was an assemblage of coiled springs. In others, the rubber was replaced by a system of wire which, on being bent out of shape, stored up the power to reassert itself. In another, perhaps the last evolved during the war and certainly one of the most ingenious, centrifugal force was utilized, without previous storage of power.

Under the heading of bombthrowers as above defined should also come the class of pneumatic guns, certain representatives of which figured in the war on both sides, but owing to the general similarity of these to normal (*i.e.* explosive-propellant) trench ordnance they are treated along with the latter.

In naval usage, on the contrary, the term is applied to explosive-propellant derivatives of trench ordnance which were mounted on trawlers and other craft for the purpose of attacking submarines. The object was to throw for a certain distance very heavy charges of explosive that, equipped with a hydrostatic fuze, would act in the same way as depth charges. These bombthrowers are dealt with under ORDNANCE: *Naval Gunnery*.

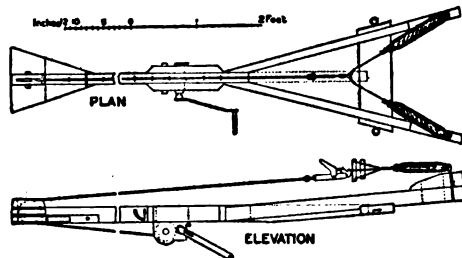

FIG. 1.

The first form of catapault to become a regulation weapon in the British army in France was the "Leach," used in 1915-6. This was a strong forked wooden frame (fig. 1) about 7 ft. in length from front to rear, the width at the splayed end or fork being about 1 ft. 10 in. Near the ends of the forked arms or "horns" were attached two sets of powerful rubbers, the rubbers of each set being firmly bound together at the extremities. The inner ends of these sets of rubbers were attached to the pouch or bomb receptacle of the catapault, which, when the rubbers were out of tension (and the pouch therefore in its forward position), was about 1 ft. 9 in. from the front of the fork. When, in order to fire, the rubbers were pulled back to extreme tension the pouch was less than a foot from the tail end of the frame. This pulling back was effected by a wire attached to the rear of the pocket, which passed round a pulley on the tail to a gear-box on the underside of the frame. This gear-box contained a winding-handle, gear, and a retaining-pawl: when the handle was turned, the wire was drawn into the gear-box (the pawl preventing its unwinding) and the rubbers extended. A bomb was then placed in the pouch, and on the word or signal to fire a trigger release broke the connexion between the pouch and the wire, and the rubbers, reasserting themselves violently, propelled the bomb.

With a heavy type of grenade weighing 1½ lb. the Leach catapault was capable with new rubbers of a range of 200 yd., and like other bombthrowers it possessed the important advantage, as against trench mortars, of invisibility and silence in action. The main disadvantage, the rapid wear of the rubbers, could be overcome by the frequent issue of replacements, the rubbers being regarded as "consumable" stores. There was, however, a limit to the practical usefulness of this cheap and efficient weapon. Its ranging powers were unnecessarily great for grenade work proper and not great enough for the tasks which came to be assigned to the trench mortar. Accordingly, a lighter and more portable weapon of the same type was designed later by Capt. G. H. Wicks of the British Trench Warfare Department. This was easily portable and manageable by one man, and ranged, with the 1½ lb. bomb, to about 100 yards. It was, however, not used in the field, as the line had by that time (1916) been drawn clearly between trench-ordnance projectiles and grenades. The heavy 1½ lb.-2 lb. grenade having ceased to exist, the necessity for a weapon to propel it ceased also.

The catapault of the French army, known as the "Sauterelle," was smaller and more portable, but correspondingly less powerful, than the Leach. It was a magnified crossbow, acting by the reassertion of springs bent in cocking.

The "West" spring gun, used by the British army in 1915 and to some extent in 1916, was a heavier and more powerful weapon. It derived its energy from a group of strong coiled springs; for extreme range, no less than 28 of these springs were brought into action. The general principle of action is shown in fig. 2. The weapon having been well bedded in with sandbags for steadiness, the throwing-arm which carries the bomb-cup is forced back-

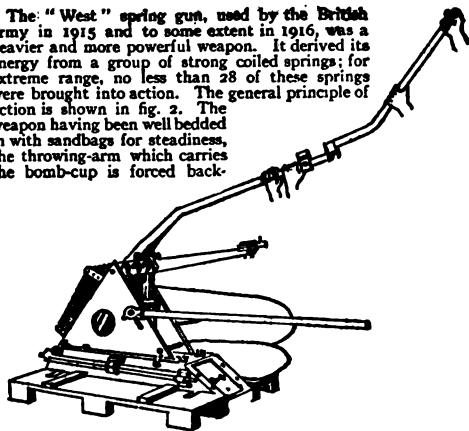

FIG. 2.

wards and downwards, against the resistance of the springs, by means of a long lever inserted in an appropriate position for leverage. When the "trigger bar" on this arm engages with a member called the trigger hook (visible in the drawing under the bomb-cup arm), the gun is cocked. The long lever is removed, a bomb placed in the bomb-cup, and the gun is then fired by pressing on the horizontal lever which actuates the trigger release. This disengages the trigger hook from the trigger bar, and under the force of the springs the throwing-arm, carrying the bomb, flies up. The range obtained with this weapon using a 2 lb. bomb was about 240 yd., 24 springs only being in action. Variation of range was obtained, as in the catapults, by varying the tension, but also, in this case, by adjustments of the position of the bomb in its cup. The West spring gun was an ingenious design, which probably comes near the limit of efficiency obtainable in applying the force of springs to an act of throwing. But it was heavy, and not very easily managed, and required as large an emplacement as a trench mortar.

The Minucciani bombthrower, though it appeared late in the war—after trench engines of the 1915 type had had their day—was probably the most efficient and ingenious weapon of its class. It was a large metal casing, circular, supported on a pedestal. Inside the casing was a revolving member, formed somewhat after the fashion of a centrifugal pump. Grenades of a special design (disc percussion) were fed into the "pump" through an opening in the casing, and when the pump was operated by turning a handle, they were expelled by centrifugal force through another opening in the casing. Extraordinarily high rates of fire combined with accuracy were obtained with this machine, which could throw the bombs practically as fast as they could be fed in, while, owing to their shape, the grenades themselves ranged well.

Other types of engine developed in the war for throwing grenades differed fundamentally from these in that an explosive propellant was employed. Setting aside certain throwers which are hardly distinguishable from light trench mortars (for which see TRENCH ORDNANCE) and throwing-devices attached to the service rifle (*see* GRENADE), there remains a type in which the grenade is formed with a sleeve tail and the thrower consists essentially of a peg over which this sleeve fits, the propellant charge being loaded into the sleeve. The action is thus exactly the reverse of that of a gun or trench mortar. An engine of this type, known as the "Hay pocket howitzer," was experimented with in Great Britain but never adopted as a service store. The Belgian "Van Deuren" type and the German *Grenatwerfer*, on the contrary, were both used in large numbers and the latter especially played a part not only in trench warfare but in the open warfare of 1918 in which it was carried by the infantry in their advance for the purpose of reducing machine-gun nests.

The *Grenatwerfer* of the German army was issued on a large scale, 12 being allowed for each infantry regiment. There were two models, of which the later, that of 1916, is here described.

The equipment comprised the thrower and baseplate (weighing 53 lb.) and a metal platform (weighing 35 lb.). The "gun" (*see* fig. 3) consisted of a cylindrical firing-peg screwed into a body. This body (which was provided with a carrying handle) had at its rear end trunnions which rested in trunnion seatings fixed to a small baseplate, as in German trench mortars. Elevation was given by clamping the body at the desired angle to an arc on the left side which was rigidly attached to the baseplate. Laying for direction was done by moving the baseplate (and with it the whole system)

round a pivot situated at the front end of the platform, and clamping it when on the desired line.

The grenade as such is dealt with under **GRENADE** while this article is concerned only with its tail. This is a hollow tube, fitting over the firing-peg, and having at the inner end of the cavity a propellant charge contained in either a service rifle cartridge (with the bullet removed) or else a capsule with a percussion cap. The interior of the firing-peg is formed in somewhat the same way as the interior of a rifle-bolt, that is, it carries a striker, striker-rod and striker-spring which are controlled by a trigger. On the right side is a cocking-lever by which the striker-rod is forced back against its spring till the notch formed on it is engaged by the sear of the trigger. When the

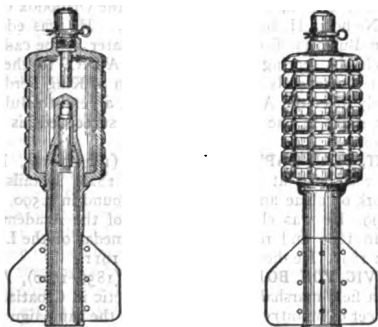
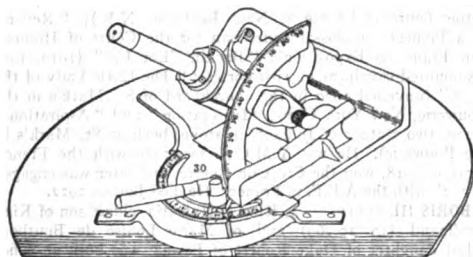

FIG. 3.

grenade, with its propellant cartridge or capsule, is placed on the peg and the safety pin of its fuze withdrawn, the trigger lanyard is pulled, the sear frees the striker rod, which is impelled forward by its spring and fires the cartridge cap, exactly as in a rifle. Until 1918 this weapon used only simple H.E. bombs. In that year a second type was introduced in which a small repellent charge in the head of the bomb was fired on impact with the ground, causing it to rebound and so to burst in air instead of burying itself. The ordinary (1915 model) grenade weighed 1.85 kgm. (4 lb.) and had a range of about 330 yards. The bouncing bomb was heavier (2.5 kgm., 5½ lb.) and ranged only to 275 yards. (C. F. A.)

**BOMBTHROWERS, NAVAL:** see **ORDNANCE**.

**BONE, MUIRHEAD** (1876- ), British etcher and painter, was born at Glasgow in 1876. He was educated at Glasgow, afterwards studying in the school of art in that city, and in 1897 and the following years produced some excellent work in black and white for the *Scotts Pictorial*. He established himself in London in 1901, where he quickly made a reputation by his etchings. He was elected to the New English Art Club, and was prominent in founding the Society of Twelve. In 1906 his etching "The Great Gantry, Charing Cross," was bought by the National Art Collections Fund and presented to the British Museum. During the World War his services were enlisted by the British War Office for the production of pictures of the western front, and some of these were subsequently reproduced in volume form.

**BONI, GIACOMO** (1859- ), Italian archaeologist, was born at Venice April 25 1859 and educated in Venice, Pisa and in Austria and Germany largely by making student journeys

through the provinces of the ancient Roman Empire. He became successively superintendent of the architectural school of the Royal Academy of Venice, inspector of antiquities under the Ministry of Public Instruction, commissioner for the monuments of Rome, and, in especial, director of the excavations in the Roman Forum and on the Palatine Hill, begun in 1899 (see 23,591 *et seq.*). These he has described in numerous reports, and he has also published a report on the campanile of St. Mark's at Venice, which was rebuilt under his direction and completed in 1910. He was given honorary degrees by both Oxford and Cambridge, and is a member of the Superior Council of Antiquities and Fine Arts for the kingdom of Italy. In 1918 he unearthed on the Palatine Hill a Greek marble statue of Victory dating back to the 5th century B.C. Besides his reports on Roman antiquities he published *Hibernica*, notes on burial places and customs of ancient Ireland (Eng. trans. 1906).

**BOOT, SIR JESSE, BART.** (1850- ), British business man, was born at Nottingham June 2 1850. He started a retail chemist's business in a small way in that town, but gradually extended it until branches were established, with factories in connexion, in most of the towns in the United Kingdom. He became chairman of Boot's Pure Drug Co., Ltd., and also of Boot's Cash Chemists, Ltd., which later added lending libraries and departments for the sale of fancy goods to the various chemist's shops under their control. In 1920 he sold the whole of his business to the United Drug Co. of America, under whose control a new company was formed with the title Liggett's International, Ltd., for the purpose of taking over other drug concerns in England and Canada. In 1921 he formed Sir Jesse Boot's Social Trust, Ltd., a registered company with nominal capital £50,000 in 10,000 £5 shares, to find out "by investigation the best means of removing or alleviating poverty, distress, and other social evils, and promoting social service." He became its chairman and governing director, his wife and Mr. J. W. Briggs, secretary of the Notts. C.O.S., being the other directors. He received a knighthood in 1909 and a baronetcy in 1916.

**BOOTH, CHARLES** (1840-1916), English sociologist (see 4,238), died at Gracedieu Manor, Leicester, Nov. 23 1916. A tablet to his memory, erected in the crypt of St. Paul's cathedral, London, was unveiled by Mr. Austen Chamberlain Dec. 15 1920.

**BOOTH, WILLIAM** (1829-1912), "General" and founder of the Salvation Army (see 4,239). Towards the close of his life he became blind through cataract, losing the sight of one eye in 1909, and of the other, after an operation, three months before his death. But he had continued to direct the operations of the Salvation Army, and learned to write without the aid of sight. As late as 1909 he had undertaken his sixth motor-car campaign. His last public appearance was made at the Albert Hall, London, May 9 1912, at a meeting to celebrate his 83rd birthday. He died in London Aug. 20 1912. His intense faith, profound and tireless sympathy, and disinterested devotion, had won for "General" Booth a unique place in the social and religious world. In the early nineties of the 19th century he might have passed away simply as the fanatical hot-gospeller of a new sect of street-corner psalm-singers; it would have been incredible then that he should end his life as one for whom Westminster Abbey was seriously suggested as an appropriate resting-place, one of the autocrats of the religious world, the creator of a world-wide organization of social service.

His son, **WILLIAM BRAMWELL BOOTH** (b. 1856), was chief-of-staff to the Salvation Army from 1880 to 1912, and succeeded his father as "general" in 1912. His wife, whom he married in 1882, had been commissioner and leader of the women's social work of the Salvation Army in the United Kingdom since 1884. In 1920 she was made J.P. for the County of London, and in 1921 was elected one of the visiting justices for Holloway prison, where women convicts are confined.

**BORAH, WILLIAM EDGAR** (1865- ), American politician, was born at Fairfield, Ill., June 29 1865. He studied at the Enfield, Ill., Academy and entered the university of Kansas with the class of 1889, but did not finish his course. He was

admitted to the bar in 1889, practised at Lyons, Kansas, 1890-1, and thereafter at Boise, Idaho. He was an unsuccessful candidate for the U.S. Senate in 1902, but was elected in 1907 and again in 1913 and 1919. At the time of the split in the Republican party in 1912 he opposed the nomination of President Taft but refused to bolt and follow Roosevelt, although in sympathy with his policies. In 1913 he was a vigorous opponent of Secretary Bryan's proposal to create a U.S. protectorate over Nicaragua. The same year he introduced an unsuccessful bill for raising the income tax exemption to \$4,000. He had long favoured a Federal levy on incomes but thought that with the then existing system of indirect taxation the additional burden should fall upon the well-to-do. He favoured woman suffrage and independence of the Philippines, but was opposed to the league to enforce peace on the ground that it tended toward internationalism. He strongly opposed many of the measures of President Wilson's administration, and in particular the League of Nations, against which, as a delegate-at-large from his state, he was an effective speaker at the Republican National Convention of 1920.

**BORDEN, SIR FREDERICK WILLIAM** (1847-1917), Canadian statesman (see 4.245), failed to secure reelection to the Dominion Parliament in 1911 and retired from politics. He had been created K.C.M.G. in 1902 on the occasion of the coronation of Edward VII. He died at Toronto Jan. 6 1917.

**BORDEN, SIR ROBERT LAIRD** (1854- ), Canadian statesman (see 4.245), became leader of the Conservative Opposition in the Canadian House of Commons in Feb. 1901, on the resignation of Sir Charles Tupper. This position he held until 1911, when the Laurier Administration was defeated on the Taft-Fielding Reciprocity Compact with the United States; he was then called upon to form in Oct. 1911 a new administration and was sworn of the Privy Council Jan. 1 1912, taking office as president of the King's Privy Council of Canada in the new Cabinet. For the purpose of more effectively carrying on Canada's part in the World War he formed, in Oct. 1917, a Union Government, comprising members of both the Liberal and Conservative parties, in which he took office as Secretary of State for External Affairs. The Union Government was returned to power in the general election of Dec. 17 1917. Borden was a member of the Imperial War Cabinet and Imperial War Conference 1917-8 held in London, England, but owing to ill health resigned the premiership in 1919. He was created G.C.M.G. in 1914.

**BORGLUM, GUTZON** (1867- ), American sculptor, was born in Idaho, March 25 1867. His father was a physician who emigrated from Denmark in 1864. He was educated at St. Mary's College, Kan., studied art at the school of the San Francisco (Cal.) Art Association, and during 1890-3 attended the Académie Julien and the Ecole des Beaux Arts in Paris. He then returned to America for a year, but in 1896 went to London, and during the next five years exhibited much sculpture and painting there and in Paris. In 1902 he moved his studio to New York. In 1904 he received a gold medal for sculpture at the St. Louis Exposition. He was a member of numerous organizations, including the Royal Society of British Artists and the Société Nationale des Beaux Arts, France. He was a disciple of Rodin and a leader of the insurgency in America. His theory of representing history by sculpture is thoroughly in accord with that of ancient Greece. The huge scale of many of his conceptions can be compared only with that of antique Oriental monuments. For example, he proposed a Confederate memorial on Stone Mt. near Atlanta, Ga., to be cut in relief along the face of that granite mountain as a frieze representing an army on the march, conspicuous from a great distance. In 1919 he exhibited a head of Lincoln cut from a block weighing six tons. The same year he was chosen to design a monument for Warsaw, commemorating the rebirth of Poland. Among his colossal figures are the Twelve Apostles for the cathedral of St. John the Divine, in New York, and another head of Lincoln in the rotunda of the Capitol at Washington. Other works include the Sheridan monument in Washington;

"Mares of Diomedes" and "Ruskn" in the Metropolitan Museum of Art, New York; statue of Lincoln, Newark, N.J.; statue of Henry Ward Beecher, Brooklyn; the Wyatt Memorial, Raleigh, N.C.; "The Flyer" at the university of Virginia; gargoyles for a Princeton dormitory; "Wonderment of Motherhood" and "Conception."

**BORGLUM, SOLON HANNIBAL** (1868-1922), American sculptor (see 4.250), brother of the foregoing, completed many important statues after 1910, including "God's Command to Retreat" (1911, Napoleon on horseback in a snow drift, bronze); "Jacob Leisler," first governor of New Amsterdam (1911, heroic figure in bronze at New Rochelle, N.Y.); "Reverie of a Pioneer" (colossal equestrian for the Court of Honour, San Francisco Exposition); "Backin' 'Em Up" (1919, four dismounted cavalymen, with horses); "The Little Lady of the Dew" (unveiled 1920 in the churchyard of St. Mark's in the Bouwerie, New York City); "Inspiration" and "Aspiration" (1920, two statues of Indians, in stone, both at St. Mark's in the Bouwerie). He was Y.M.C.A. secretary with the French army in 1918, won the Croix de Guerre, and later was engaged in work with the A.E.F. in France. He died Jan. 31 1922.

**BORIS III.** (1894- ), King of Bulgaria, eldest son of King Ferdinand (see 10.269) and of Marie Louise de Bourbon, eldest daughter of Duke Robert of Parma, was born at Sofia, Jan. 30 1894. Although his parents were Roman Catholics, the prince was, on Feb. 14 1896, received into the Orthodox church, the Tsar Nicholas II. being his god-father. He was educated entirely in Bulgaria, first by tutors and later at the cadet and officers' schools, serving subsequently as A.D.C. to the King and to various generals. On the abdication of King Ferdinand, immediately after the Armistice which put an end to Bulgaria's disastrous share in the World War, Boris succeeded his father, Oct. 4 1918.

**BORNET, JEAN BAPTISTE EDOUARD** (1828-1911), French botanist, was born at Guéridy Sept. 2 1828. Details of his special work on algae and lichens will be found in 1.590, 16.578 and 26.899. He was elected a member of the Académie des Sciences in 1886 and received the gold medal of the Linnean Society in 1891. He died in Paris Dec. 17 1911.

**BOROEVIC VON BOJNA, SVETOZAR** (1856-1920), Austro-Hungarian field-marshal, was born at Umetic in Croatia. As a young officer of infantry he served through the campaign for the occupation of Bosnia in 1878, and afterwards on the general staff until he reached the rank of general. In the World War he first led the VI. Corps in the victorious battle of Komarow, and as commander of the 3rd Army beat off the Russian attacks in the Carpathians until May 1915. He then took over the command on the Isonzo. His name is for ever associated with the 11 victorious battles fought in the defence against Italian armies twice as numerous as the Austrians and considerably better equipped. After the collapse of the monarchy the Yugoslav Government refused the "black and yellow" general permission to return to his province.

Boroevic embodies the type of the Croat general of the past in the more polished mould of the present. By iron industry he had acquired the fullest mastery of the science of war, as a general in the field he was distinguished by his intuitive judgment of the enemy, by his tenacious energy, and by his ingenuity as a tactician.

**BOSANQUET, BERNARD** (1848- ), English philosopher, was born at Rock, near Alawick, June 14 1848. Educated at Harrow and Balliol College, Oxford, he was for ten years a lecturer at University College, Oxford (1871-81). In 1881 he came to London; and until 1897 engaged in lecturing and social work. He married in 1895 Helen Dendy, herself the author of books on social problems. During 1903-8 he was professor of moral philosophy at St. Andrew's University. He became a fellow of the British Academy. A Hegelian in philosophy and a disciple of T. H. Green, his logical tenets are described in 16.886, 888 and 917.

Amongst his published works are *Knowledge and Reality* (1885); *Logic, or the Morphology of Knowledge* (1888); *Essentials of Logic*

(1895); *Psychology of the Moral Self* (1897); *Principles of Individuality* (1911); *What Religion Is* (1920) as well as translations of Hegel and Lotze.

**BOSNIA-HERZEGOVINA** (see 4. 279).—Until Oct. 1918 Bosnia-Herzegovina remained a territory of the Austro-Hungarian Empire. A proclamation issued on the occasion of its annexation to the Habsburg Monarchy in 1908 promised these lands constitutional institutions, which should secure to their inhabitants full civil rights and a share in the management of their own affairs by means of a local representative assembly. In performance of this promise a constitution was promulgated on Feb. 10 1910. This included a Territorial Statute (*Landesstatut*) with the setting up of a Territorial Diet, regulations for the election and procedure of the Diet, a law of associations, a law of public meetings, and a law dealing with the district councils (*Besirskrštite*).

According to this statute Bosnia-Herzegovina formed a single administrative territory under the responsible direction and supervision of the Ministry of Finance of the Dual Monarchy in Vienna. The administration of the country, together with the carrying out of the laws, devolved upon the Territorial Government in Sarajevo, which was subordinate and responsible to the Common Ministry of Finance. The existing judicial and administrative authorities of the Territory retained their previous organization and functions. The statute guaranteed generally the civil rights of the inhabitants of the Territory, namely citizenship, personal liberty, protection by the competent judicial authorities, liberty of creed and conscience, preservation of the national individuality and language, freedom of speech, freedom of learning and education, inviolability of the domicile, secrecy of posts and telegraphs, inviolability of property, the right of petition, and finally the right of holding meetings.

The Diet (*Sabor*) set up consisted of a single Chamber, elected on the principle of the representation of interests. It numbered 92 members. Of these 20 consisted of representatives of all the religious confessions, the president of the Supreme Court, the president of the Chamber of Advocates, the president of the Chamber of Commerce, and the mayor of Sarajevo. In addition to these were 72 deputies, elected by three *curiæ* or electoral groups. The first *curia* included the large landowners, the highest taxpayers, and people who had reached a certain standard of education without regard to the amount they paid in taxes. To the second *curia* belonged inhabitants of the towns not qualified to vote in the first; to the third, country dwellers disqualified in the same way. With this curial system was combined the grouping of the mandates and of the electors according to the three dominant creeds (Catholic, Serbian Orthodox, Moslem). To the adherents of other creeds the right was conceded of voting with one or other of the religious electoral bodies within the *curia* to which they belonged.

All males 24 years of age, and natives of and residing in the Territory, possessed the franchise, as also Austrian and Hungarian citizens engaged as officials in the administration and on the railways in Bosnia-Herzegovina. Qualifications for election as deputy were the same as for the franchise, save that the minimum age limit was fixed at 30, and public officials and teachers were excluded. The law on district councils created a district council (*Besirskrat*) for every district (*Beairk*) to take part in the administration of local public affairs.

*The Diet*.—On June 25 1910 the first session of the Diet of Bosnia-Herzegovina was opened. Shortly before this the Emperor Francis Joseph had visited the country for the first time, and had met with an enthusiastic reception. The Diet was composed of three great religious parties. The strongest was that of the Serbs (Orthodox), the next that of the Moslems (Mahomedan), and lastly that of the Croats (Catholics). Each of these parties struggled for the hegemony, but since none commanded a majority, efforts at coalition began among the three groups. The opposition between Serbs and Croats, which had come more sharply into evidence after the annexation, had become softened, and all three parties combined in a

demand for far-reaching autonomy. The constitution had not contented the political parties, since it did not satisfy the desire in the country for full self-government. The Government had not a strong majority on the opening of the Diet, but under the favourable impression produced by the Emperor's visit, the first budget laid before the Diet was approved even by the opposition groups, and in this the Government saw also a kind of vote of indemnity for their administration in pre-constitutional times. The Diet started a fruitful activity, and the Government was able to secure a majority, consisting of Croats, Moslems and moderate Serbs.

In the spring of 1911, during the discussion of the Road Construction Bill, the language question for the first time led to quarrels in the Diet in connexion with the notices on signposts; throughout the year party wrangles, discontent with the constitution, and the obstructive tactics of the radical Serbs hampered business; and the Government no longer had a certain majority. Early in 1912 the Austro-Hungarian Minister of Finance, Baron Burian—the author of the Bosnian constitution—resigned office, and was succeeded by Ritter Leo von Bilinski. To the new minister the representatives of the various parties in the Diet presented a memorandum asking for a revision of the constitution and of the rules of procedure in the Diet; for an alteration of the electoral law; for a Government responsible to the Diet and at least partly recruited from among its members; for an extension of the sphere of activity of the Territorial Government in political and economic matters; for an independent policy of railway rates, the appointment of an audit office for the financial control of the Government, and the regulation of the language to be used by officials and functionaries. The object for which the parties were striving became more and more evident: the greatest possible autonomy for the Territory of Bosnia-Herzegovina and independence of the central Government of Vienna. With the rejection of the budget of 1912 began an open conflict between the Government and the parties in the Diet which had as its result a long pause in the activity of the Diet.

After wearisome negotiations and the acceptance by the Government of a series of the demands set forth in the memorandum, a combination of Croats, Moslems and moderate Serbs, in a working majority, was arrived at during the summer of 1912, under which conditions the third session of the Diet was opened on Oct. 22. The Government succeeded in obtaining the indemnity for the 1912 budget, and passed through the Diet a great number of the laws which it had drafted. New difficulties cropped up in the discussions of the proposed law on the language question. The draft law specified Serbo-Croatian as the future official language in all affairs, both internal and external, connected with the civil administration, with public educational establishments, and State railways so far as their external traffic was concerned. The parties also demanded Serbo-Croatian as the official language of the railways in Bosnia-Herzegovina itself; but this the Government refused to concede; and, since no agreement could be reached, the Diet was prorogued, and the fourth session was not opened until Dec. 20 1913.

For this session the Government had managed to secure a working majority consisting of Croats, Moslems and moderate Serbs. The language law and several other important measures were passed. A resolution was also carried in support of a law drafted by the Government with a view to a solution of the agrarian question which should do equal justice to the interests of the landlords and the *Kmet*s (see AGRARIAN QUESTION p. 474).

The business of the Diet was suddenly interrupted by the assassination of the Archduke Francis Ferdinand at Sarajevo on June 28 1914. The session was closed on July 9, and on Feb. 5 1915 the Diet was dissolved. Owing to later political developments, ending with the break-up of the Austro-Hungarian Monarchy, there were no new elections. In spite of political obstacles the Diet had done much towards the development of the constitution, and during its four sessions had framed



numerous laws, many of which were important. Their discussion was generally conducted on a notably high plane and bore witness to a thorough and many-sided examination of the matters requiring consideration.

**Administration.**—According to the census of 1910 the pop. of Bosnia-Herzegovina on Oct. 10 1910 numbered 1,998,044 persons, of whom 52.4% were males and 47.6% females. As compared with the year 1895 the population showed an increase of 21%. The civil pop. of the capital, Sarajevo, had risen from 38,000 to 51,000 persons. According to religion the population was divided as follows:—

825,418 Serbian Orthodox	= 41.5%
612,137 Moslems	= 32.2%
434,061 Catholics	= 22.9%

The remainder was composed of other religious creeds. According to occupation the figures were:—

Agriculture	. . . . . 87%
Industry	. . . . . 5.5%
Trade and Commerce	. . . . . 3%
and in the public service and the liberal professions in round numbers	. . . . . 2%

Of the whole pop. from the age of seven upwards 87-84% were illiterate. The part taken in the public service by the indigenous element was on the increase (in 1908, 31%; in 1910, 44.5% of all public officials).

Pupils of the secondary schools in Bosnia-Herzegovina who passed on to the universities or other higher educational institutions of the monarchy, on their return entered the Government service or the liberal professions.

The number of public schools in Bosnia-Herzegovina during the period 1910-8 was, at its highest, as follows: 568 elementary schools, 4 higher elementary girls' schools, 3 training colleges for male and female teachers, 9 trade schools, 1 commercial academy, 2 technical schools, 1 special technical school, 4 grammar schools (*Gymnasien*), 2 higher *Realschulen*, 1 lower *Realgymnasium*, 1 military lower *Realschule*, 3 theological colleges.

In addition to these there were numerous denominational and private elementary schools, Turkish *mektebs* and *medreses* (lower and upper Moslem schools) and three private grammar schools. In 1911 the Diet unanimously decided upon compulsory school attendance for four years for children over seven years of age. In 1885 the *Landesmuseum* was founded, and provided with a modern building in 1912. It contains collections of scientific, artistic and historical interest. In 1912 was established the Bosnian and Herzegovinian Institute for research connected with the Balkan Peninsula. Worth attention are the *Wissenschaftliche Mitteilungen aus Bosnien und Herzegovina*, published by the Museum, of which the 13th and last volume appeared in 1916.

The Press underwent a rapid development. In 1914 there appeared 43 periodicals, six of which were daily papers, three weeklies, and 32 monthlies. Of these 38 were published in the Serbo-Croatian, two in German, and the rest in both languages. There was also a great increase in clubs and societies, which in 1913 numbered 833 with 102,000 members, one-third of them being Serb.

**The Agrarian Question.**—Shortly before the opening of the Diet in 1910 a strong agitation had begun among the *Kmeti*, i.e., peasants holding of the great landlords under the *metayage* system and, in some cases, by personal services in addition (see 4.280). In 1911 the Diet unanimously passed a law for the conversion of these tenancies into freeholds by voluntary agreement between landlords and tenants with Government assistance. For this purpose the Government was empowered to issue bonds (*Kmetenablosungobligationen*) and a special office (*Kmetenablosungsamt*), akin to the Irish Land Commission, was established at Sarajevo to carry out the law. The process of redemption now proceeded rapidly. Whereas during the 33 years (1879-1911) 32,681 *Kmet* tenancies had been converted into freeholds at a cost of 29 million kronen, 13,371 were converted between June 1911 and the end of 1915. According to the calculations of the Sarajevo office, redemption in this form, which proceeded without friction and had no unfavourable influence on the existing agrarian situation, would have been completed within 20 years.

**Military Service.**—In the year 1913 a new military service law came into force in Bosnia-Herzegovina, by which the liability for military service was put on the same footing as that in Austria-Hungary. The *Landsturm* was not introduced into Bosnia-Herzegovina, but in its place the 2nd and 3rd Reserves were formed. Liability for military service began with the completion of the 10th year of age, and ended in the year in which the man liable for service completed his 42nd year. By a law of 1915 the military service law was modified to make the liability for service for the duration of the war extend from the end of the 18th to the end of the 50th year of age. The military establishment for Bosnia-Herzegovina comprised four infantry regiments and one *Feldjäger* battalion.

**Public Health.**—In the field of public health the Diet decreed in 1914 the extension of the Territorial hospital in Sarajevo, and the erection of larger hospitals in the chief town of each district (*Kreis*) and of smaller hospitals in the chief town of each sub-district (*Bezirk*), and granted 12 million kronen for this purpose. The execution of this decree was interrupted by the war, but an open-air

hospital for tuberculous patients was erected in Sarajevo. The water supply of Sarajevo was extended, and in 11 towns a water supply was either newly provided or extended. The co-operation of the town councils in the sphere of public health and other administrative affairs was of considerable importance. The budget of the Sarajevo town council for 1914 made a demand for 4 million kronen, those of all the other town councils together 5 million kronen. In many places electric light was introduced.

**Justice.**—In the sphere of justice the independence of judges in the exercise of their judicial functions, and their security of tenure, were established by law, together with the responsibility of the judges for damage caused by a breach of their professional duty. Inspectors of the law courts were introduced, the setting up of a house of correction for women in Zenica was decreed, and law courts erected in Sarajevo which included all the courts in Sarajevo and the prison. In 1914 an audit office was set up to supervise the expenditure of the administration.

**Agriculture.**—The most important branch of production in Bosnia-Herzegovina had always been agriculture, in which 87% of the population were employed. The efforts of the Government for the improvement of agriculture (agricultural departments, schools of viticulture and fruit culture, ploughing demonstrations, loans for implementation of agriculture, schools of rural economy, Sunday instruction) were continued.

The statistics of the harvest for the most important crops in 1914 were:—

	Cwt.
Wheat	2,024,000
Oats	1,400,000
Barley	1,171,000
Maize	6,272,000

Among fruit crops the leading one is that of plums, which was always of the highest importance. The crop statistics of this kind of fruit fluctuated greatly:—

1912: in a raw state	330,715 cwt.
1914: in a raw state	6,877,000 cwt.

Of the 1914 crop there were also 2,161,000 cwt. dried plums; 25,600 cwt. were converted into *Lequar* (pulp) and 1,570,000 cwt. devoted to immediate consumption. The residue was used for making the liqueur known as *Sisoviza*.

Stock-breeding plays a great part in the agriculture of Bosnia-Herzegovina, being favoured by the extraordinarily rich production of hay. The census of cattle in 1910 produced the following figures for live stock:—

Horses, asses and mules	228,831 head
Cattle	1,309,922 head
Goats	1,393,068 head
Sheep	2,499,422 head
Pigs	527,271 head

**Industries and Manufactures.**—Industry is rapidly developing in Bosnia-Herzegovina, and is principally directed towards the exploitation of the natural resources of the country, e.g. in forestry, mining, and manufactures of chemicals and tobacco. To forestry and mining in particular great importance attaches. The total area under forest in Bosnia amounts to 50% of the whole, or 9,800 sq. m., 75.8% of which are State forests, the rest private property or *Vakuf* belonging to Moslem religious foundations; 60% of the woodlands are marked out for timber forests. The exploitation of these woods supports many great forestry establishments employing large capital. In 1913 there were in the country 31 steam saw-mills, whose plant for transportation of wood comprised 176 m. of gravitation lines and 630 m. of steam railways. In the period 1908-1, 230,000 tons of forest products were exported, a value of 83.5 million kronen.

Among mining industries the first place is occupied by the coal mines, financed by the Territorial treasury, of Tuzla, Zenica, Kakanj-Doboj, Breza, Banjaluka, Ugljevik, and Maslovarc which produced on an average 800,000 to 1,000,000 tons of coal yearly. Of these mines Maslovarc was newly opened in 1917.

Bosnia's production of iron ore is rich. From 1891 onwards *Vareš* had already been occupied in the production of ore and its conversion into pig-iron and other foundry products, but the working of the great ore deposits of Ljubija near Prijedor was only begun during the war, and the raising of the necessary capital (about 16 million kronen) undertaken. The works can cope with a daily production and transport of 300 wagonloads of ore. The deposits consist of a high-grade iron ore showing a proportion of up to 50% of iron.

In 1912 a Geological Institute was set up, the most important task undertaken by which was the construction of a new geological map of Bosnia and Herzegovina. The general map was planned to consist of six sheets on a scale of 1/200,000, and in 1921 the sections Sarajevo and Tuzla had been issued.

Among the chemical and other industries existing in 1910-8 were: one alkali factory, one carbide and chloride of lime factory, one salt distillery, one cellulose factory, one petroleum refinery, one alcohol distillery, several breweries, a sugar manufactory and, finally, four tobacco factories.

For the protection of workmen compulsory sickness insurance was introduced in 1910, and preparations were completed for legislation as to compulsory accident insurance for workmen. An industrial inspector had already been appointed before this.

**Finance and Trade.**—Numerous new credit institutions were at the disposal of the economy of Bosnia and Herzegovina. The Austro-Hungarian Bank set up three branch establishments in the country, and in addition 15 new credit institutions were founded, among them the Serbian and Moslem Central Bank which, together with the Croatian Central Bank, which was founded earlier, represent native capital. In 1914 a Post Office Savings Bank was set up.

The chief statistics of foreign trade were published annually by the statistical department. The last publication appeared in 1913:—

Imports: 460,000 tons of goods and 40,000 head of cattle (in round figures).

Exports: 1,090,000 tons of goods, and 207,000 head of cattle.

The total turnover of foreign trade in 1913 amounted to 368.8 million kronen, 59.2% of which represented imports and 40.8% exports.

The export and import of goods in the years 1910-3 amounted to the following:—

	Tons	Imports	Mill. Kr.
1910	303,800		144.5
1911	352,800		154
1912	392,000		174
1913	460,600		200.7
		Exports	
1910	1,078,000		132.9
1911	1,058,000		121.8
1912	1,078,000		130.2
1913	1,087,800		138.1

There were in the period 1910-8 1,300 m. of main roads and 930 m. of railways. A law was passed by the Diet sanctioning the construction of 463 m. of new railways on the normal gauge and 65 m. narrow gauge, including the new sections Banjaluka-Jajce, Samac-Doboj, Bugojno-Aržano, Bugojno-Rama, Brčko-Tuzla-Bjelina-Rača. The costs were estimated at 270 million kronen. For payment of the interest and sinking-fund on this loan Austria and Hungary pledged themselves to pay a yearly contribution of 10 million kronen for 60 years. Of these projected lines construction was begun in 1914 on the sections Banjaluka-Jajce, Bugojno-Aržano, and Samac-Doboj but interrupted owing to the outbreak of war. The construction of the section Nivi-Bibač was begun in 1914 and continued during the war.

The traffic on the State railways of Bosnia-Herzegovina amounted to:—

	Goods Traffic	Passenger Traffic
1910	225 million net kilometre tons	119 million
1913	284 million net kilometre tons	181 million.

During the period of the war the traffic showed a decrease in goods, but an increase in passenger-travelling owing to army transport.

The economic and cultural development of Bosnia-Herzegovina from the first years of the occupation till the end of the Austro-Hungarian Government is reflected in the development of the budget to the administration of these territories. The first complete budget was drawn up in the year 1880, and provided for expenses to the amount of 6 million gulden (12 million kronen). In the year 1914 the expenses amounted to 110 million kronen with an equal credit balance. The administrative expenses and the revenue thus increased nearly tenfold in the period 1878-1918. Financial activity during this time was considerable, and based exclusively on money raised in the country. For the construction of railways and common undertakings loans were raised which produced in round figures 200 million kronen.

With the break-up of the Austro-Hungarian Monarchy in Oct. 1918 Austro-Hungarian rule in Bosnia-Herzegovina also came to an end. On Nov. 1 1918 the newly formed National Government (*Narodna Vlada*) in Sarajevo declared that it took over the government of the country and broke off all connexions with the former central Government in Vienna. Subsequently the territories of Bosnia-Herzegovina proclaimed their union with the newly founded State of the Serbs, Croats and Slovenes. (O. v. K.)

**BOSTON** (see 4.290).—The pop. of the area incorporated as "the City of Boston" was in 1920, 748,060; in 1910, 670,585, an increase of 77,475 or 11.6%, being by far the smallest percentage of increase in the history of the city, and the smallest numerical increase for 50 years. But the two figures are not precisely comparable, as the municipal area was increased from 43 to 48 sq. m. in 1912 by the inclusion of Hyde Park which in 1910 had a pop. of 15,507. During the five years 1915-20 the increase of pop. was less than 1%. The "metropolitan area," constituted by the Legislature of Massachusetts for certain purposes of common action, includes in addition to municipal Boston 38 adjacent

cities and towns and had in 1920 a pop. of 1,641,756 (according to the provisional U.S. census returns), and in 1910 1,423,439. The percentage of pop. in "the city" as compared with that of the "metropolitan" area thus decreased from 47.8% in 1910 to 45.5% in 1920.

**Commerce.**—Boston's coastwise trade is important, the tonnage being much larger than that of its trans-Atlantic commerce. Boston is still second only to New York in export of meat and dairy products; and is the largest leather, wool, and fish market in the world. The port's foreign commerce is shown in the following tables:—

	Vessels in Foreign Trade			
	Entered:		Cleared:	
	Number	Net Tonnage	Number	Net Tonnage
1910	1,355	2,714,382	1,136	1,828,887
1915	1,488	2,463,651	1,161	1,659,802
1920	1,089	2,021,152	850	1,293,681

This shows a falling off in 10 years of: vessels entered 20%; tonnage entered 26%; vessels cleared 25%; tonnage cleared 30%.

Imports and Exports of Boston District		
	Imports	Exports
1910	\$129,006,184	\$ 70,516,789
1915	152,953,791	107,475,677
1920	456,246,322	281,614,919

**Manufactures.**—The following table shows the value of products and of materials and the amount paid in wages in the years 1909, 1914 and 1918:—

Manufactures of Metropolitan Boston			
Year	Value of Products	Value of Materials used	Wages paid
1909	\$ 510,583,337	\$284,354,062	\$ 93,125,349
1914	584,115,582	323,455,579	107,139,932
1918	1,240,496,193	737,506,555	210,781,794

First in importance among manufactures is outer footwear \$216,392,449 (leather boots and shoes \$101,811,715, boot and shoe cut stock \$70,105,251, and rubber boots and shoes \$44,475,483). Next in importance are: slaughtering \$98,047,594, machinery and foundry products \$91,155,376, printing and publishing \$51,193,923, men's and women's clothing \$41,670,664, confectionery \$37,088,668. These are the industries in which growth has been most rapid, but not rapid enough to overcome the slowing down as compared with other industrial centres. The increase in value of product due to the World War in the years 1914-8 was rapid, but did little more than keep pace with the increase in prices. The total increase in the number of persons thus employed from 1913, before the war, to 1918, the period of highest production under war pressure, was 40,235, following which, however, a large number of employees was laid off. With immigration of foreign workers, the constricted industrial opportunity has caused increasing numbers of native born to move away from Boston. The actual increases in population have been largely in the ranks of the immigrant peoples, 35% of the inhabitants of municipal Boston being in 1915 foreign born (24% of them Irish, 17% Russian, 16% Italian, 5% English, 3% German, 35% all other nationalities). Of the municipal pop. in 1915, 72% was wholly or in part of foreign parentage.

**Railways.**—During the 10 years 1910-20 the subway system was enlarged. The Boylston addition from Arlington to Kenmore street (1911-4) and the extension under the Common over the Charles river basin and underground in Cambridge to Harvard square (1914-8) developed a system 9 m. long at a cost of \$36,366,000. These new subways with the elevated system have given central clearance and ease of transfer throughout the district. The cities and towns have permitted several of their interurban lines to be abandoned. They have permitted many of their roads and streets to go into disrepair, but the motor transport service by private initiative has been greatly increased. The second transportation requirement—the need for equipment to keep in touch with outside markets—has not been met. Boston has failed to provide adequate terminal and storage facilities: and it is constricted in its railway service. There are three railway systems that look to Boston for clearance and outlet: the Boston & Maine, the Boston & Albany, and the New York, New Haven & Hartford. But the lack of facilities for transfer from one system to another makes Boston virtually three ports instead of one—competitors with each other instead of with outside ports. The cities to the north (as Lowell, Lawrence, etc.,) only a few miles from Boston) often find it of advantage to ship via New York. The same is true for freight originating on each of the three systems.

**Education.**—The public-school system is under state guidance and patronage (see MASSACHUSETTS). The growing interest in higher education is reflected in the table below. It is significant that

Boston University and the Massachusetts Institute of Technology, which have undertaken to provide technical and professional training to students who meet entrance requirements, have increased their student enrolment far more than any of the other institutions.

Registered Attendance at Chief Colleges and Universities.

	Harvard	M. I. T.	Simmons College	Boston College	Tufts	Boston Univ.	Radcliffe	Wellesley
1910-11	4,123	1,506	785	194	1,142	1,153	500	1,378
1915-16	5,226	1,900	1,083	487	1,541	1,984	683	1,512
1920-1	5,667	3,475	1,253	735	2,128	2,718	652	1,551
Incr.	37%	131%	60%	279%	86%	570%	30%	13%

The trend of higher education has been toward increasing opportunity for the masses. This is shown not alone by the increasing number of full-time college students, but also by the rapid growth in the number taking part time "University Extension Courses." In Harvard, for example, the number taking these courses increased 96% from 1910 to 1920; in Boston University, 187%; under the direction of the State Department of Education the number increased from 1,360 in 1916 to 24,231 in 1920, nearly one-half of these students being registered in metropolitan Boston. The estimated number for 1921 was 30,000.

Municipal Boston in 1920 had 264 permanent and 137 portable school houses, besides 21 rented quarters for schoolroom use; provided 130,669 school sittings; and employed 3,413 teachers; also 97 assembly halls and 15 drill halls and gymnasias. It had 52 park and 32 schoolyard playgrounds; employed 153 recreation teachers, 46 school physicians, 48 school nurses, and 25 attendance officers. In 1919 it registered 122,452 regular day-school pupils; 8,260 in evening schools and 9,651 in continuation schools. The registration in normal, high and latin schools for the same year was 17,018. Of the pupils 82-6% were in public schools, and 17-4% in private schools.

**Buildings, Libraries and Museums.**—In 1910 the old Museum of Fine Arts was demolished and on the site was erected the Copley Plaza Hotel, built at a cost of \$3,800,000 and opened in 1911. The new building of the Museum of Fine Arts, erected on Huntington Ave., was opened Nov. 15 1909, and a second section opened Feb. 3 1915, the total cost at that time being \$3,900,000. To the State House east and west wings were added during 1914-9, at a cost approximating \$3,000,000. John Sargent's series of panels in the public library was practically completed in 1916, when he added a third sequence, the "Theme of the Madonna." In Jan. 1919 the public library contained 1,197,498 volumes (922,348 in Jan. 1908). It continued to be the largest free circulating library in the world, with a circulation of 2,300,732 for 1919 (1,529,111 for 1907). The New England Conservatory of Music remained the largest in the United States, having in 1919 3,700 students. The Boston Opera House was erected on Huntington Ave. in 1909.

**History and Finance.**—Boston, as a metropolitan district, has retained much of the institutional structure of the old towns which have grown together and become consolidated for certain purposes by legislation. Several things have happened in the 10 years 1910-20 indicating a drift toward political unification. What was called the "Boston 1915" movement resulted in better business leadership, in more ample support given to the chamber of commerce and other trade bodies; and legislation looking toward a unified harbour place. A new charter adopted in 1909 gave to the city a small council (9 members) elected "at large." In 1920, under the leadership of Mayor Peters, a first effort was made to consolidate the several independent cities and towns under a "Greater Boston" charter. In many ways the whole metropolitan district had developed the habit of acting together, as was exemplified in the Liberty Loan and Victory Loan drives, the results of which were as follows: First Liberty Loan \$133,790,360; Second Liberty Loan \$147,250,650; Third Liberty Loan, \$77,202,500; Fourth Liberty Loan, \$139,008,150; Victory Loan, \$83,852,700; total amount subscribed \$581,113,350.

Boston's *per capita* expenses continued to be the largest of any American city; but in the 10-year period ending in 1918 the net debt increased only 17-11%. The average yearly expenditure for the five years ending in 1917 was \$32,990,507, excluding payments on funded and floating debts. The running expenses *per capita* in 1917 were \$31.68 (New York, \$25.64; Chicago, \$22.26). The

Metropolitan Water Board, of whose expenditures Boston bears only a share, expended from 1900 to 1919 \$22,463,201. The system has a capacity of 80,000,000 gallons. The city park system cost from 1899 to 1919 \$1,954,738. The city debt in 1919 was \$80,908,397 (gross debt \$124,410,101); this included the debt of Suffolk county, which in 1919 was \$1,435,335. The chief objects for which the city debt was created were in 1919: highways, \$21,600,000; parks, \$10,750,000; drainage and sewers, \$21,540,000; rapid transit, \$36,340,000. Boston paid in 1919 27-4% of all state taxes, and about 32-65% and 81% respectively of the assessments for the metropolitan sewer, parks and water service. The city's tax valuation in 1919 was \$1,586,153,778, of which only \$198,863,678 represented personality. (F. A. CL.)

**BOTANY** (see 4.299, with references on p. 302 to separate articles on botanical subjects).

**I. Introductory.**—Any attempt to record the progress of botanical science during the decade 1910-20 is made peculiarly difficult by the fact that specialization has rendered it impossible for any one person to keep abreast of all its manifold advances. In the following survey, the subject is accordingly treated in separate sections. Special reference, however, may be made here to the remarkable developments of applied botany which have been a feature of progress in England. The development of forestry (*see FORESTRY*) is now recognized as a function of the State and the Forestry Commission is actively engaged in schemes for the promotion of research. The Ministry of Agriculture, which had previously established a number of agricultural research stations, has not only been able to make provision by increased endowments for larger and more adequately remunerated staffs of investigators, but has also established two new stations of first importance. These stations, located together at Cambridge, are the seed testing station and the national institute of agricultural botany. The ultimate object which the former will achieve is increased agricultural production by an improvement in the quality of seed. The latter which owes its existence to the initiative of Sir Lawrence Weaver and to the financial assistance of the Ministry of Agriculture, the Development Commission and members of the agricultural industry, aims at increasing production by the carrying out of large scale tests of the truthness, cropping capacity and specific usefulness of plants of agricultural importance. To this end the station not only tests both existing and new varieties but provides for the working up of stocks of new and promising varieties on a scale sufficient to ensure adequate supplies for commercial use.

Scientific horticulture has also received a great impetus by the enlargement of the Royal Horticultural Society's experiment station at Wisley. Already the investigations conducted at the various experimental stations have led to results of great botanical importance. Of these may be mentioned the researches conducted at the John Innes Horticultural Institute on self-sterility of fruit trees, those at the East Malling and Long Ashton stations for research in fruit trees, problems which have resulted in an important advance in knowledge of fruit-tree stocks—a subject of equal botanical and horticultural importance.

The close association which has been established between the department of practical physiology and pathology at the Imperial College of Science, South Kensington, on the one hand, and the research stations at Rothamsted and East Malling, on the other, marks an advance in organization destined to have an important and beneficent influence on the progress of botanical knowledge; for as it is certain that progress in applied science must depend on the pioneer work of pure science, so is it no less certain that applied science quickly discovers problems which would otherwise long await the interest and attention of the worker in pure science. (F. KS<sup>7</sup>)

**II. General Physiology.**—The most striking aspect of advance in plant physiology of recent years is the further development of the attempt to relate the fundamental activities of the cell with the colloidal nature of protoplasm. Protoplasm is considered to be of the nature of a hydrosol with protein and lipid material, and possibly carbohydrate, as its disperse phase. It may, however, assume temporarily during life, or permanently at death, the condition of a gel, as is shown by the cessation of the

Brownian movement of the particles (see Bayliss, *Principles of General Physiology*, 1918). On the basis of the colloid nature of the plasma membrane many of the phenomena of cell permeability may be explained. On the colloid theory of protoplasm, the living organism has been defined as "a specific complex of dynamic changes occurring in a specific colloid substratum which is itself a product of such changes and which influences their course and character and is altered by them" (Child, *Senescence and Rejuvenescence*, 1915).

Further investigation of the fundamental process of carbon dioxide assimilation has confirmed the work of F. F. Blackman and his school, which showed that the rate of the process is controlled mainly by temperature, light intensity and concentration of carbon dioxide. Any one of these factors may control the rate of the process and so act as a "limiting factor." The amount of chlorophyll, since it controls to a large extent the amount of light absorbed, should also be a controlling factor, and Willstätter and Stoll (*Untersuchungen über die Assimilation der Kohlenstoffe*, 1918) have shown that this is so. With the help of the methods of extracting and estimating the leaf pigments developed earlier by Willstätter they have been able to relate chlorophyll content with rate of assimilation. Their observations have brought out the interesting fact of the importance of some unknown factor (possibly of enzymic nature) which may be termed the protoplasmic factor. The existence of this factor is demonstrated by the observation that, relative to the amount of chlorophyll it contains, the assimilating activity of a yellowing leaf may be many times that of a green leaf. The existence of some such factor is also demonstrated by the observations of Miss Irving (*Annals of Botany*, 24, 805, 1910) and Briggs (*Proc. Roy. Soc. B.*, 91, 249, 1920), who demonstrated that during the greening of etiolated leaves chlorophyll appears some time before the process of assimilation begins. Osterhout (*Jour. General Physiol.*, 1919) and Warburg (*Biochem. Zeit.*, 100, 1919) have confirmed the high temperature coefficient of the process of carbon assimilation which was first demonstrated by Matthaei. This high temperature coefficient shows clearly that the process of carbon assimilation is not solely a photochemical process but is linked with one or more "dark" reactions. Warburg has also been able to show that light which was intermitted 16,000 times a minute—the light and dark periods being of equal length—caused as much assimilation as continuous light of the same intensity. Light received intermittently by the plant was thus twice as effective as that received during continuous illumination. Reference must also be made to a work of great value, Jørgensen and Stiles' critical review of investigations of carbon assimilation up to the year 1917 (Jørgensen and Stiles, *Carbon Assimilation*, 1917; originally published in the *New Phytologist*, 1916-7). An important method of estimating assimilatory activity under natural conditions by following the growth of the leaf area and of the dry weight of the whole plant was first used by Gregory (*Report Exper. & Res. Sta. Cheshunt*, 1918), and has been employed by Briggs, Kidd and West (*Annals of Applied Biology* VII, 1920). The permeability of the living cell is another aspect of plant physiology which has received much attention; but although many observers have studied the rate of entry or exit of substances, it cannot be said that great progress has been made in elucidating the mechanism of absorption, accumulation and translocation. Measurements of electrical conductivity have been largely used for estimating the rate of passage of electrolytes in or out of the cell, and methods based on the rate of deplasmolysis have also been employed. Stiles and Kidd (*Proc. Roy. Soc. B.*, 90, 1919) using carrot slices and the conductivity method, have estimated carefully the rate of the entry of the cations and anions of a number of simple salts, the rate of entry being apparently related to the mobility of the ions. They have confirmed, using, however, a more satisfactory method, the work of Nathanson on the balance between the concentration of salts inside and outside the cell. They show that with weak external solutions there is a very marked "heaping up" of material in the cell. For example, at equilibrium the concentration of potassium chloride in the cell may be 25 times that of the external solution. The mechanism of accumulation is obscure, but the equilibrium appears to follow the adsorption law. That marked and repeated changes of permeability can occur in the living cell has been shown by Osterhout (*Science*, 35, 1912; *Bot. Gazette*, 59, 1915; and other papers), who used the method of measuring the effect of various salts on the electrical resistance of a pile of discs of the thallus of *Laminaria*. The electrical resistance is taken as a measure of the permeability to ions of the plasma membranes. Increases of 50% and decreases of 20% in the resistance could be sustained repeatedly without injury. Lepschkin and Tröndle have demonstrated that changes in permeability can be brought about by light, and so must be normal phenomena in the life of the cell; and Blackman and Paine (*Annals of Botany*, 32, 1918), using the electrical conductivity method for determining the rate of exosmosis of electrolytes from the pulvillus of *Mimosa*, have been able to follow the change continuously and have demonstrated that although light increases and darkness decreases permeability, yet the sudden change from light to darkness causes a sudden small increase of

exosmosis which is soon, however, followed by a rapid decrease. The question of the meaning of the growth process and its analysis have engaged the attention of many workers on both the animal and vegetable side. Robertson especially has applied an auto-catalytic equation to express the growth period of an ordinary organ, but as shown by Enriques it is only one of a number of possible equations. Mitscherlich (numerous papers from 1909 onwards in *Landw. Jahrb., Land. Versuchs-Stat.*, etc.) has put forward an equation to express the relation of crop yield to external factors, based on the supposition that the increase of the deficient factor is effective in proportion to the departure of the yield from the maximum yield obtainable. V. H. Blackman (*Annals of Botany*, 33, 1919) has laid stress on the fact that the plant increases on the continuous compound interest principle, since with increase of leaf area its capacity for assimilation increases, and this leads to a still further increase in the rate of assimilation. The rate at which dry material is added, assuming it to be added continuously, is termed the "efficiency index."

J. C. Bose has continued his investigations of the growth and irritability of plants (*Researches on Irritability of Plants*, 1913, and *Transactions of the Bose Institute*, 1918). He has devised a special instrument, the high magnification Crescograph, by means of which the elongation of plant organs can be magnified more than a million times. By this instrument not only can very minute contractions and expansions be observed but also changes which occur in as short a time as a fraction of a second. Bose has also investigated in great detail the various electrical responses to stimulation which plants exhibit. He has shown, for example, that when a stem which contains movable starch grains in its endodermis is placed horizontal, a marked difference of potential is to be observed between some neutral point (such as a leaf) and the interior of the stem. It was further demonstrated by the use of a probe, in the form of a fine insulated platinum point which could be forced into the tissue of the stem, that the potential of increase of leaf area is highest when the point of the probe is in contact with the endodermis of one side of the stem, falls to a minimum when the probe reaches the centre of the stem, and rises again to a maximum (but with the direction reversed) when the probe reaches the endodermis at the other side of the stem. These observations provide additional evidence of the part played by the statoliths of the endodermis in the geotropic response.

In the field of irritability the most important new point of view put forward is that of Blaauw (*Med. Landow.*, Wageningen, 15, 91, 1919) on the nature of the phototropic reaction. This investigator first concentrated his attention on the effect of light as such, apart from light direction. He made a very careful series of experiments with the sporangiophore of *Pilobolus* and the hypocotyl of *Helianthus*. By an ingenious arrangement of mirrors the plant was illuminated equally all round with electric light of various intensities. The rate of growth was measured every few minutes, and thus it was determined that the "light growth reaction," as Blaauw terms it, is a very complex effect. With continuous light *Phycomyces* shows a latent period of 3-9 min., and then the rate of growth begins to rise, reaching in 7-9 min. a maximum increase of 41-74%. The increase is followed by a fall and then several rises and falls follow, the normal rate of growth being finally reached, except with very high intensities. A similar result is obtained with *Helianthus*, but the main effect is a reduction of growth instead of an increase as in *Phycomyces*. Blaauw explains phototropic effects as quite independent of light direction, holding that they are really due to the different intensity of the illumination of the two sides—as de Candolle maintained long ago. The fact that both *Phycomyces* and *Helianthus* show a positive phototropic reaction while the light growth reactions of the two are opposite in nature, is explained by the lens-like action of the glassy sporangiophore, which causes a higher light intensity on the further side. Buder confirmed this explanation for he has shown that by placing the sporangiophores in paraffin oil, which abolishes the lens action, the response is reversed. The root of *Sinapis alba* shows a negative light growth reaction and negative phototropism, but here again, owing to the shape of the apex, the side away from the light is the more highly illuminated. Blaauw claims that plants have no mechanism for the perception of light direction, and that there is no such thing as a real phototropic reaction, but only a light growth reaction. (V. H. B.)

III. *Chemistry of the Sap Pigments of Plants.*—Flowers derive their tints from two very different classes of coloured compounds, termed plastid and sap pigments respectively. The former include chlorophyll, carotin, xanthophyll and allied compounds, and are not soluble in water. Chlorophyll rarely enters into flower colourings, but compounds of the carotin and xanthophyll group are responsible for most of the bright yellow and orange flower colours, whilst in the presence of anthocyanes they yield browns, bronzes, etc.

The sap pigments are water-soluble glucosides, and may in the main be subdivided into two groups. One group, the flavone and flavonol colours, contains compounds which, though usually present in the cell sap of flowers, rarely give rise to colour effects as they are

pale yellow or colourless unless in the form of alkali salts. In certain cases a fraction of a % of a carotino colour may cover completely more than 20% of a flavonol colour. The researches of A. G. Perkin and others have resulted in the isolation and examination of a large number of the members of this group, whilst the investigations of Kostanecki have led to their synthetic preparation.

Colours of the second group of sap pigments are called anthocyanins, (the glucosides being termed anthocyanins; the non-glucosides, anthocyanidins). They give rise to the red, purple and blue colours in flowers, and owing to their brilliant effects, have long been the subject of speculation and research. It is only recently, however, that their chemical nature has been disclosed. Willstätter and Everest obtained the pigment of the cornflower in a pure state, and proved that it exists in the flowers as a glucoside. They also showed that by change in the condition of the cell sap one pigment may produce red, purple or blue colours: red in the presence of an acid cell sap, purple if the sap be neutral and blue if it contain the pigment in the form of an alkali salt. Indeed the same pigment (cyanin) has been isolated from red roses and from the blue cornflower. These observations have been extended by Willstätter and Mallison to show how when the presence of pigments of the other groups is allowed for, all variations of flower colours can be explained. Shibati, Shibati and Kasiwagi have recently put forward alternative suggestions to account for flower colours, but much of their experimental evidence has been shown by Everest to be untrustworthy. Other chemical work by Willstätter and by Everest has elucidated the chemical structure of anthocyanin pigments, has shown that they are products of the reduction of the flavonols, and has led to their synthesis. The accompanying formulae show how closely anthocyanin pigments are related to the yellow flavonol compounds. (I.) represents kaempferol, a flavonol isolated by A. G. Perkin from a species of larkspur, and (II.) represents pelargonidin, which is the anthocyanin pigment present in the flowers of various species of pelargonium.

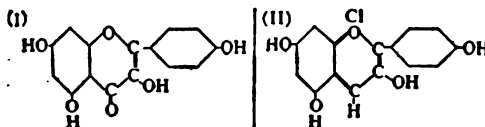

A considerable number of these pigments has now been isolated in a pure condition. It is interesting to note that the honour of having first prepared crystals of these pigments outside the plants falls to the botanist H. Molisch. Both in the yellow sap pigments and in the anthocyanins, the individual pigments only differ from other pigments of their own group in the number and position in the molecule of OH, methoxy, or sugar groups.

Before the relationship between flavonol and anthocyanin pigments had been demonstrated by chemical means, much botanical work had been carried out on this problem, notably by Wheldale and by Koeble, Armstrong and Jones. These investigations confirmed views expressed many years previously that there was some definite connexion between the yellow sap pigments and the anthocyanins. They also led to the belief that the anthocyanin pigments were formed from flavonols. This belief has been greatly strengthened by the proof of the close chemical relationship that exists between the two groups of pigments, and by the work of Everest, Willstätter and Combes, which proved that flavonols could readily be converted into anthocyanins. Moreover Everest has shown that in all probability the anthocyanin present in the Black Knight *viola* is accompanied by the flavonol pigment from which it would be produced by reduction.

A number of flavonol compounds has been found to exist in plants in the sugar free condition, but thus far only one anthocyanin has been definitely proved to exist in nature in the non-glucoside form—that occurring in black grapes.

It is of interest to mention that whilst many of the yellow sap pigments have long been used as mordant colours for commercial dyeing processes, and are so still used to some extent in Europe and more in the East, the beautiful anthocyanin pigments also have well marked tinctorial properties and yield fine shades on tannin mordants. In the non-glucoside condition they have affinity for metallic mordants, but owing to their lack of fastness in washing their use to any large extent is commercially impracticable.

Beyond the two main groups mentioned above, sap pigments exist which differ in constitution from the members as investigations proceed. Doubtless the number of these will increase as investigations proceed. An interesting case is that of the pigment of the "Red Pea Gall" recently investigated by Nierenstein.

For reference to the literature see M. W. Onslow, *Practical Plant Biochemistry* (1920); M. Wheldale, *The Anthocyanin Pigments of Plants* (1915); A. G. Perkin & A. E. Everest, *The Natural Organic Colouring Matters* (1918); Shibati, Shibati & Kasiwagi, *Jnl. Amer. Chem. Soc.*, vol. 41, p. 208 (1919); Everest & Hall, *Proc. Roy. Soc.*

B, vol. 92, p. 190 (1921); Everest, *Jnl. Soc. Dyers & Colourists*, vol. 34, p. 47 (1920); M. Nierenstein, *Jnl. Chem. Soc.*, vol. 115, p. 1328 (1919).

IV. *Mycology*.—The recognition of the primary importance of the physiological point of view as compared with the older morphological (or systematic) point of view was prominent as the inspiration of perhaps the most important work in plant pathology during the period 1910-20. In England the brilliant work of Blackman and his school laid the foundations for a scientific knowledge of the physiology of infection by parasitic fungi. These studies have been concerned with *Botrytis* (Blackman and Welford, 1916); (Brown, 1915-17); *Colletotrichum* (Dey, 1919) and *Synchytrium endobioticum* (Curtis, 1920).

The study of specialized or adaptive parasitism has been followed with fruitful results. The validity of the conception of "bridging species"—involving as it does a certain physiological plasticity of the fungus—which was accepted by Marshall Ward and Salmon, has been alternately affirmed and denied. Pole-Evans (1911) has asserted that a rust when growing on the susceptible *F. hybridus* may thereby become capable of infecting the immune parent used in the cross; Freeman and Johnson (1911) have stated that barley acts as a "bridging species" for biologic forms of *Puccinia graminis* on other cereals. On the other hand, the number of investigators is increasing who, working with isolated strains of the parasitic fungus under rigidly controlled conditions, have found no evidence for the existence of "bridging hosts." The admirably systematized and patient researches of a band of workers in America, headed by Stakman, seemed destined to solve this most important question of the constancy, or plasticity, of the "biologic form." The complexity of the problem may be gauged by the fact that a considerable number (at least 22) of "biologic forms" of *P. graminis* on wheat have now been discovered—a fact explaining why the same variety of wheat may be immune in one locality and susceptible in another (Stakman, Piemeisel, Levine and Leach, 1917, 1919).

Specialized parasitism has been studied also by Barrus (1918), who has found local "biologic forms" of *Colletotrichum lindemuthianum*; by Rood (1912-8) and Vavilov (1913) in the *Erysiphaceae* and by Fischer (1912-7) in the *Uredineae*. In England Wormald (1919), investigating the "brown rot" (*Sclerotinia*) diseases, has discovered the existence of two "biologic forms" in *S. cinerea*, of which one, capable of causing a blossom wilt and canker disease of the apple, is characterized by a more abundant secretion of oxidase. Brierley (1919-20) working with single spore cultures of strains from a "mixed population" of *Botrytis cinerea* has shown that their phenotypic characters are modifiable but are specific in relation to constant factors.

As illustrating the physiological bent of many important researches that have been made, the following may be mentioned:—the relation of soil temperatures to root infection (Jones and Gilmán, 1914-6); (Tisdale, 1916-7); (Edson and Shapovalov, 1920); relations of temperature and humidity to infection by certain fungi (Lauritzen, 1919); (Brooks and Cooles, 1917); relations of some rusts to the physiology of their hosts (Mains, 1916); chemical changes produced in host tissues (Hawkins, 1916); (Rose, 1915); relations between climate and disease (Stevens, 1917); influence of soil conditions on *Thielavia* (Johnson, 1919) and *Pseudomonas citri* (Lee and Fulton, 1920); physiological studies on spinach showing "Mosaic" disease (True *et al.*, 1918); effect of the "black rot" fungus on the chemical composition of the apple (Culpepper *et al.*, 1916).

The bionomics of "potato blight" (*Phytophthora infestans*) have been much studied. The investigations of Melhus (1915) and Pethybridge (1911) have thrown light on the nature of the primary seasonal outbreaks; Clinton (1911) made the notable discovery that oospores are formed by the fungus when grown on a certain artificial medium—a fact confirmed by Pethybridge and Murphy (1913). Eriksson (1917-8) has stated that "mycoplasma" and non-resting oospores occur in "blight-infected" potato leaves; since, however, this observer now sees "mycoplasma" in so many directions (rust on cereals, rust on hollyhock (1911), mildew on the gooseberry) independent confirmation of its existence in at least one of the cases is necessary before the "mycoplasma" hypothesis can be accepted. Evidence in marked opposition to Eriksson's statements as to the primary outbreaks of hollyhock rust has been published by Bailey (1920).

From the study of bacterial diseases of plants, no previous period of ten years had seen the collection of so rich a harvest of facts. The indefatigable work of Erwin F. Smith constitutes by itself an invaluable library of exact information. In his researches (1912-20) with *Bacterium tumefaciens*, the organism causing "Crown gall" in plants, proof has been obtained that the gall formed at the point of infection gives rise to tumour strands which push their way through the surrounding tissues and develop secondary and tertiary growths, analogous to what is found in animal sarcoma, carcinoma and embryoma. Numerous other workers, e.g. Morse (1917) in the United States, Doidge (1915-9) in South Africa, and Paine



(1907-9) in England, have been rapidly adding to our knowledge of this group of parasites.

Among the notable outbreaks of plant diseases which have occurred are the American gooseberry mildew (*Sphaerotheca morosae*) originally introduced from America and now fixed past all eradication in the fruit-growing countries of Europe; the terrible "wart disease" of the potato (*Synchytrium endobioticum*) neglected in the early days of its appearance in Great Britain and now firmly entrenched in the Midlands, in Wales, in the seed-growing districts of Scotland and sporadically elsewhere in England, reaching in 1920 to the great potato-growing county of Lincolnshire. On the Continent it has appeared in Hungary, Holland, Sweden, Germany etc. Such is the virulence of this potato disease that in infested soil potato growing becomes impossible unless recourse is had to an immune variety. The disease has been made the subject of much international legislation, affecting export trade. In 1918 it appeared in the United States in miners' gardens among the coal-fields of Pennsylvania; a strict quarantine has been established round the infested regions, and a publicity campaign has been started in America with an organization and vitality unknown in Europe, the results of which later years will reveal. In South Africa, Australia and America the Citrus canker (*Pseudomonas citri*), originally introduced on a plant from Japan, has swept through the citrus plantations with devastating results. In South Africa the canker eradication campaign up to 1919 had cost over £60,000. In the United States the white pine Blister Rust (*Cronartium ribicola*), which was introduced into America from Europe about 1892, continued to make steady progress in the white pine regions of the eastern and north-eastern states, notwithstanding that for several years a coordinated campaign by the State and agricultural organizations had been in progress, under which "scouts" and "State eradication crews" destroyed wholesale the species of *Ribes* which constitute the alternate host of this heterocercous Rust. In one survey of an area of 72 sq. m. in New Hampshire, one-fourth of the pines was found to be infected. The Chestnut Bark disease (*Endothia parasitica*), which appeared in 1904 in a park in New York, increased to such an extent that by 1921 losses of hundreds of millions of dollars had already been caused and it threatened to destroy every chestnut wood in North America. This disease, probably introduced from Japan, girdles and kills the chestnut tree; its spores are distributed from tree to tree by the wind, insects and birds.

Renewed warfare (reminiscent of the Massachusetts Barberry law of 1755 and the similar law in Denmark in 1903) has been declared in the United States against the barberry. In 1916 it was estimated that Black Rust (*Puccinia graminis*) on wheat caused a loss of nearly 200 million dollars in the United States. This Rust is heterocercous and field observations in the States have shown that the aecidiospores from the barberry start, in the spring, epidemic outbreaks of Rust on wheat.

Another group of diseases which excites alarm in the United States and also in Europe is the "Mosaic" diseases or "infectious chlorosis." A prominent American pathologist has said of this class of diseases "it gives one the creeps," so obscure is the cause, so infectious is it and so increasing prevalent is a rapidly increasing number of host plants (potato, tomato, tobacco, cucumber, spinach, bean, red clover, sugar-cane, maize, grasses). The investigations of a band of workers, among whom may be mentioned Allard (1914-8), Brandes (1920), Doittle (1920), Schultz *et al.* (1919), appear to show that the cause of those menacing diseases is an ultramicroscopic organism, rather than an enzyme as previously supposed. On some plants the disease is freely transmitted by certain sucking insects, such as *Aphides*. In Europe the chief example is the disease of the potato called "Leaf curl," the subject of important investigations by Appel (1911) (1915), Quanjer (1913-20), Doby (1911-5), Artschwager (1918), Neger (1919) and Murphy and Wortley.

The decade ending in 1920 was rich in investigations bearing on the scientific control of plant diseases. Stimulated by the now classic discovery made by Biffen in 1907, that the inheritance of Rust resistance follows on Mendelian lines, workers in genetics (see GENETICS) in many countries, e.g. Nilsson-Ehle, Biffen, Pole-Evans, Stakman, Parker and Piemeisel, and Hayes, Parker and Kurtzweil, have been engaged in the breeding of disease-resistant plants. It has been shown that resistance and susceptibility to Rust can hardly be considered as simple characters, the  $F_2$  results giving evidence in favour of the multiple factor hypothesis. Immunity from, or resistance to, many different types of fungous diseases has been sought for and found, either by selection or cross breeding, in many genera of economic plants. Varieties of beans and sugar-cane immune to "Mosaic disease" have been discovered (Reddick and Stewart, 1919); Earle (1919); beans immune to *Colletotrichum*, found by Barrus (1915) and used in cross breeding by Burkholder (1919) and McKroste (1919); asparagus resistant to Rust (Norton, 1913); resistance to citrus canker (Peltier, 1918); wilt (*Fusarium*)—resistant cottons, tomatoes, cabbages and flax (Orton); potatoes, English, German and American varieties, immune to "wart disease" (Malthouse, Snell *et al.*); Werth (1919), Marlatt (1919); potatoes immune to "blight" (Salaman, 1910); cereals immune to *Krypsile Graminis* (Vavilov, 1913); Reed; hops immune to *Sphaerotheca Humuli* (Salmon, 1917-20).

Of great importance, economically, has been the scientific study of fungicides. The great work of Pickering (1907-12) in elucidating the chemistry of "Bordeaux mixture" profoundly affected the method of making copper-containing washes. Additional knowledge has been gained by the researches of Sicard (1914) and Vermorel and Dantony (1914) in France, Ewert (1912) and Wöber (1919) in Germany, Mond and Haberlein (1919) in England, and Butler (1914-20) in America. Gimingham and Barker (1911-14) showed that a biological rather than a chemical explanation holds good for the efficacy of copper-containing fungicides on the sprayed plant.

A notable advance, accelerated in many countries by wartime organizations, has been made in the legislative control of plant diseases by the State. In most countries the grower is now required by law to notify the outbreak of certain infectious diseases of plants. In Great Britain "wart disease" of the potato (*Synchytrium endobioticum*) has been the subject of numerous legislative orders, whereby the sale of "seed" potatoes, and their import and export, are controlled; and the grower prohibited from growing susceptible varieties of potatoes in affected districts. On the other hand, the State, by a system of inspection, guarantees the purity of stocks of immune varieties. Other recent examples of legislation against fungi in England are the "Silver leaf" order of 1919 and the Onion Smut order of 1920. The former was introduced to try to save the "Victoria" plum and other valuable plums from being exterminated by the "Silver leaf" disease, now definitely known, through the work of Percival and of Brooks (1911-9), to be caused by the fungus *Stereum purpureum*. The grower is now required by law to burn the dead tree—or the dead wood of the tree—on which the *Stereum* fructifications are formed. This order, however, is administered as an educational rather than as a punitive measure. The United States, in their efforts to stop the importation from Europe of new fungous pests, passed in 1912 a "Plant Quarantine Act," under the provisions of which the importation of all five-leaved species of *Pinus* from Europe and Asia was prohibited, for fear of their carrying the white pine Blister Rust also, potatoes coming from many European countries were excluded in fear of "Wart disease." Later legislation has prohibited altogether the importation of plants into the United States except under special licences. In this step South Africa has followed. In the United States, an Act to prevent fraud in the sale of fungicides and insecticides is in force, and in England, where during the World War the purity of copper sulphate for spraying was legally guaranteed, further legislation to secure the purity of lime sulphur and arsenical washes has been contemplated. Legislative measures against plant diseases commonly affect international interests, and the first of what were planned as regular international Phytopathological Conferences (interrupted, however, by the World War) was held at Rome in 1914. A Convention was signed at Rome by the delegates of some 30 states pledging themselves not only to maintain an official phytopathological service for the detection and suppression of certain diseases, but also to maintain institutes for scientific research, so that state officers may be supplied with the best technical advice. Another branch of state activity is seen in the surveys of plant diseases which are being made in many countries. The "Report" (1918) of the American plant pathologists, compiled by Lyman and others, is a document of absorbing botanical and economic interest, and from it can be gathered a good idea of the wide development of extension work with field laboratories and of "team work" in research now existing in the United States. Similar organization for plant disease surveys exists also in Germany (Appel, 1914). The Annual Reports of the Plant Diseases Branch of the Ministry of Agriculture in England, and the similar reports issued in France, Holland and other European countries, as also in India and our Colonies, are forming the basis for a world-wide census of plant diseases, the necessity for which has been so ably put forward by Sorauer and Eriksson in Europe, by Butler in India and by the leading American plant pathologists. (E. S. SA.)

**V. Soil Sterilization.**—Intensification of culture leads always to an increase in the soil flora and fauna, and among the forms that assume importance are many that are directly or indirectly harmful to plants.

It has been found that a simplification of the soil population leads to increased productiveness and greater healthiness of crop. This simplification can be brought about by mild killing agents which are not too drastic in their effect—which will kill living germs, but not all spores.

Steam heat is the most effective agent: it is so effective that it would always be adopted if questions of cost and convenience never arose. It not only kills animal pests, ova and larvae of earthworms, wireworms, woodlice, etc., and reduces fungi, but it also brings about a certain amount of useful soil decomposition, thus greatly facilitating the work of the food-producing organisms of the soil. Steam heat is used in two ways in the glasshouses of the Lea Valley in England: in one the soil is dug over, then covered with a large wooden tray under which steam is blown



for about an hour; in the other the soil is trenched in the usual way, but at the bottom of the trench is placed a grid made of iron piping perforated with holes through which steam is blown as soon as the soil has been replaced. The grid is then pulled out and placed in the next trench. The cost before the war was not less than £24 per acre, and in 1921 it varied according to the thoroughness of the steaming from about £90 to £300 per acre. In small nurseries or private glasshouses baking the soil is usually effective and is much cheaper, a coke oven being worked at very little cost. There is, however, a limit below which the cost cannot be brought, and in practice 12 tons or more of coke are needed to steam an acre of soil.

Attempts have therefore been made to find some chemical agent that will prove as effective as heat in dealing with undesirable organisms.

The method of investigation is to take each organism and find the toxicity of various chemical groupings. An example is as follows:—

Amount required to kill *Wireworms*.  
(Gram molecular weights.)

Basal Substance	Added Group	One Group	Two Groups
Benzene 100	Methyl	54	30
	Chlorine	26	8
	Bromine	14	—
	Iodine	6	—
	Amide	3.5	Non-toxic
	Nitro	3	Non-toxic
	Hydroxyl	1.4	—
Chlormethylene	0.5	—	

Proceeding in this way it is found that chlorocresol and dichlorocresol are very effective, and they are being studied on a large scale. Some complications arise from the fact that soil bacteria have remarkable powers of decomposing many poisonous substances such as carbonic acid, cresol, naphthalene, etc., and in some cases the decomposition proceeds so rapidly that the substance disappears before it has had proper time to act. This difficulty is being met by the introduction of stabilizing groups.

See E. J. Russell and H. B. Hutchinson, "Partial Sterilisation of Soil," *Jour. Ag. Sci.* 1909, iii., 111-144, 1913, v., 152-221; E. J. Russell and F. R. Pethybridge, *Jour. Ag. Sci.* 1912, v., 86-111; *Jour. Bd. Agric.* 1912, xviii., 809-826, 1913, xix., 809-827 and 1914, xx., 102; E. J. Russell, *Jour. Roy. Hort. Soc.* 1920, xlv., 237; D. W. Cutler and L. M. Crump, *Annals of Applied Biology* (1920).  
(E. J. R.)

**VI. Ecology.**—In the domain of ecology the most important work since 1910 has been the intensive study of the habitat conditions in a number of limited areas. It is on such data alone that broad generalizations can be safely based, but much more needs to be accomplished in this direction before the significance of the results obtained can be rightly estimated. Of these intensive studies it is possible here to indicate only a few. Of the numerous types of plant communities that have been investigated, forests and woodlands have received a large share of attention and well illustrate the chief lines of progress.

Descriptive or primary survey work has elucidated interesting points respecting the courses of the altitudinal and polar tree limits. The meteorological conditions above and immediately below the timber line have been shown to exhibit an abrupt change associated with the cessation of shelter, but the gradual upward extension of the tree zone is limited by climatic conditions of which the duration of the snow-free period is an important factor. Both in America and Switzerland a rise of the timber line has been noted on the larger mountain masses and, as Brockmann-Jerosch has pointed out, the polar tree limit approaches the poles on the great continental land masses whilst it recedes from them in the oceanic regions of high latitudes. In other words, a continental climate is favourable to tree growth whilst an oceanic climate is unfavourable except at low latitudes. Modifications of the altitudinal timber limit by soil and aspect have brought out the different demands and toleration of individual species. As a consequence of such changes the successive timber zones rise to a higher altitude on south exposures and on dry warm soils whilst on north aspects not only are the zones lower but they may also be more numerous. In Switzerland, for example, successive zones of chestnut, beech and larch occur on slopes facing southwards whilst on northern slopes zones of silver fir and spruce become interpolated, the lower limit of the latter being apparently determined by the diminishing rainfall. The study of the biology and physiology of the constituent forest species has served to demonstrate the adaptational character of many of their salient features. The periodicity of the herbaceous vegetation

is, for example, intimately related to that of the shrubs and trees above, the assimilation of the more specialized members of the former being chiefly carried on before the canopy of the latter is complete.

Again, it has been shown that the optimum assimilation of such plants takes place in relatively weak illumination whilst their osmotic pressure, as in the plants of other habitats, is intimately related to the humidity of the environment. This has been shown to obtain in the case of some prairie species; even for the different parts of the same individual and in the different seasons of the year. Investigations of the soil conditions in relation to the plant covering have yielded promising results. Thus, the distribution of natural vegetation seems to be largely associated with changes in such factors as acidity, water content, humus content and proportion of bases. The study of the first named has received a great impetus during the past few years, and in Sweden Hesselman has shown that the absence of natural regeneration in many forests is connected with high acidity and deficiency of nitrates.

Another aspect of vegetation is the change to be observed when the environment is altered or the original plant covering removed. The investigation of such succession phenomena has already yielded important economic results in relation to the improvement of pasture. The work of W. G. Smith in Scotland, of Dr. L. Cockayne in New Zealand and Prof. J. W. Bews in South Africa has drawn attention to the possibilities of artificial control of the natural succession. This principle is capable of wide-spread application wherever natural vegetation has an economic value; but it demands as a preliminary an intensive knowledge of the ecology of the individual species. It is as an outcome of such knowledge that Oliver has suggested the use of the plastic plant in place of groyves in fore-shore control.

On the philosophical side of the subject more has been written than the present state of our knowledge or its usefulness warrants. An extensive literature has developed on the classification of plant communities but most of these centre around one or other of four main view-points. The first emphasizes the importance of soil conditions as the basis of classification and is exemplified by the system proposed by Gola in 1910 based on his theory of osmotic edaphism. The second lays most stress on the physiognomy of the constituents of plant communities and with this are associated the names of Brockmann-Jerosch, Gams, Raunkjær, Rubel and Warming. The third, associated with the American school, lays especial stress on succession, and Clements, who has done most to develop this view, classifies plant associations according to the climatic climax of which they represent phases of development. The fourth regards floristic composition as of paramount importance and has been upheld by Braun-Blanquet, Du Roi, etc.

The first two and the last tend to result in systems that are too artificial, whilst that of Clements demands a knowledge that we often do not possess and tends to segregate phases which, though developing along divergent lines, are regarded as plant communities, more closely related to one another than to the other phases of the same succession. Ecology is in much the same position as taxonomy in the early days when systems were frankly artificial because of the inadequacy of the knowledge to establish a natural system. Doubtless in time we shall find that, as with plant groups, different sets of characters must be used for different communities; but, in the meantime, these systems, however deficient, have served as an inspiration for valuable research which is yielding that knowledge on which the classifications of the future must be based.

**REFERENCES.**—The chief literature prior to 1907 is cited by Flaahult (*Progressus Rei Botanicae*, 1907), whilst for the literature subsequent to 1913 reference should be made to the *Journal of Ecology* (1913 *et seq.*) and *Ecology* (1918 *et seq.*), the respective organs of the British and American ecological societies. The following may be consulted either as illustrating particular aspects or as furnishing extensive bibliographies: J. W. Bews, *The Grasses and Grasslands of S. Africa* (1918); J. Braun-Blanquet, *Les Cevannes méridionales* (1915); H. Brockmann-Jerosch, "Der Einfluss des Klimacharakters auf die Verbreitung der Pflanzen und Pflanzengesellschaften," *Ber. d. Schweiz. Bot. Ges.* (1919); F. E. Clements, *Plant Succession* (1916); L. Cockayne, papers dealing with New Zealand grassland. *N. Z. Jour. Agric.* (1919); H. Hesselman, papers on nitrate formation in soils, *U. Meddelanden Fran Statens Skogsforsoksanstalt* (1917); C. E. Moss, *Vegetation of the Peak District* (1913); E. J. Salisbury, "The Significance of Calcicoly," *Jour. Ecology* (1920); W. G. Smith, "The Improvement of Hill Pasture," *Scottish Jour. Agric.* (1918); A. G. Tansley, "The Classification of Vegetation," *Jour. Ecology* (1920); *Types of British Vegetation* (ed. by A. G. Tansley, 1911).  
(E. J. S.)

**VII. Horticultural Exploration.**—Botanical exploration in relation to horticulture centred during 1910-20, as in the preceding decade, in S.-E. Asia, particularly in western China. The gradual acquisition from all parts of the world of species new to cultivation has proceeded on a steady course, but the novelties from the East so far surpass in number, and in some

ways in interest, those from other regions as to warrant our speaking of this Chinese invasion as the dominant feature of plant introduction since the opening of the 20th century.

Explorers have discovered the richest relic of the Palaearctic flora, its richness conditioned by a unique assemblage of deeply river, snow-clad mountain ranges traversed by three mighty rivers—Salween, Mekong, Yangtse—of parallel course north to south separated by narrow divides, also deeply incised, across the monsoon trend. A paradise of species in the making! The first exploration with declared horticultural aims, tempted by records of the finds of French missionaries and Henry's wonderful Ichang collections, was that of Wilson, in 1899, who made Western Hupeh and Szechwan his field of work during the succeeding 14 years, later passing eastwards to Korea and Formosa. He was followed in 1904 by Forrest—still exploring—who took Yunnan and adjacent Tibet and N.-E. Burma for his sphere. Through these pioneers thousands of new species have come to our ken. Later explorers who have affected horticulture have been Purdom in Kansu, Kingdon Ward—still exploring—in the same area as Forrest, Farrer in Kansu and, later with Cox, in N.-E. Upper Burma. Among the horticultural prizes and the plants of economic value that have come to us through these explorations in the shape of shrubs and trees, there are some two to three hundred new species of rhododendron alone, and amongst herbaceous plants *primula* gives us far over a hundred novelties. Genera—to name a few—that are prominent in the number of new species of shrubs and trees, indicating clearly the nature of the flora and the plants added to cultivation, are: acer, alnus, berberis, betula, buddleia, carpinus, clematis, cornus, corylus, cotoneaster, crataegus, deutzia, euonymus, fraxinus, hydrangea, ilex, ligustrum, litchia, lonicera, magnolia, photinia, pieris, populus, prunus, pyrus, quercus, rhododendron, rosa, rubus, salix, smilax, spruce, styrax, syringa, tilia, vaccinium, viburnum, vitis; of conifers, abies, keteleeria, picea, pinus, tsuga. Similarly amongst herbaceous plants some of the noteworthy genera are: aconitum, adenophora, allium, androsaceae, anemone, aster, codonopsis, corydalis, cremanthodium, cyananthum, delphinium, didissandra, dracocephalum, gentiana, impatiens, iris, lilium, lysimachia, meconopsis, monocharis, oreocharis, pedicularis, pleione, polygomon, potentilla, primula, rheum, roscoea, saxifraga, sedum, senecio, silene, trollius, thalictrum.

To the west of this partially explored region lies a vast area unexplored extending to Bhutan, whence ere long, riches, perhaps in diminishing amount, will be gathered. Cooper at the Himalayan end of this area has done splendid exploration work over Griffith's ground in Bhutan and further east, enriching horticulture with many good plants.

Apart from the new species which these explorations have brought to horticulture, two biological problems of horticultural interest are touched especially by the work of Forrest. One is raised by the modification of form observed in the direction of specific differentiation exhibited by single phyla in relation to the multiplicity of environmental conditions offered by the exceptional physical construction of the region. It suggests possible results—positive or negative—bearing upon evolution through correlation of plants in nature with similar forms in cultivation. The other—that of humus plants growing on limestone—immediately concerns horticulture in view of the fact that rhododendron, for instance, cannot be grown in cultivation upon a limestone soil. That so many of the rhododendrons collected by Forrest have their leaves densely covered by a penetrating mycelium makes the suggestion admissible that the fungus of mycorrhiza has migrated from the uncivilized lime-soil environment to the leaf to function there—forming a mycophyllon—as a nitrogen-adjutant. The following-up of these discoveries is for the future. (I. B. B.)

**VIII. General Morphology.**—The wider problems of the origin of plant life on this world, its relation to animal organism, and above all the evolutionary progression of the flora of the land surface, have claimed the attention of successive generations of botanists. The older deductions of the Hofmeister school were admirably and lucidly summed up and amplified by Bower (1908) in *The Origin of a Land-Flora*, and this book has so held its own as a text-book that there has been little to add to it. In a posthumous volume Arber (1920, *Devonian Floras*) attempted even to visualize the actual geological epoch at which the transition took place from archaic aquatic algae to the first types of land-vegetation, as expressed in the change from a Lower Devonian flora of Thallophytes to the Upper Devonian of *Archaeopteris*. Apart from the intensive investigation of the vestigial races of Pteridophyta of the present day, or of the recent debris of Palaeozoic times, it is possible to approach the subject indirectly, and to state the nature of the problems to be solved from the new view-points opened up in connexion with the earlier phases of plant life on the world surface by the consideration of conditions of life in the sea.

Since early papers by Luther (1899) and Bohlin (1901) on the relation of the reproductive cells of fresh-water algae to flagellates, the Flagellar theory has entered on a new phase to the extent that it is now freely accepted that all phyla of plant-life, as also all animals, must be based on a flagellate ancestry: that motile reproductive cells have not been evolved specially for the reproductive purposes which they serve, but indicate the retention of an older phase of aquatic existence. To this may be added the recognition by protistologists (Doflein, 1916) of the fact that the autotrophic (plant) flagellate must be regarded as the precursor of all heterotrophic and animal flagellate phyla: while the vast variety of marine organisms in which the flagellated phase is still dominant or readily regained in reproductive stages implies that it is to the pelagic flagellates that one must look for conceptions of the origin of higher organisms, rather than to the Amoeba of fresh water or sea bottom. As shown by Pascher (1917), the amoeboid habit may be attained secondarily, in connexion with available substratum, in any line of elementary flagellate evolution. In this way the conclusion appears inevitable, not only that life as we know it arose in the sea, but from the material of sea water, as the physico-chemical constitution of protoplasm suggests at the present day. Since no other factors but those of pelagic water and solar radiation are required to determine the physiological and structural response of such living zooids, a phase of continuous deep water over the entire world surface must have obtained to give rise to such "plankton" organism. The cell-unit, of which all higher life is composed, thus represents the soma attained in such an environment, established for all time with nuclear mechanism and faculty for division and fusion, as also all plasmic functions and assets inherited as the cell equipment of plant and animal organization.

It is to the sea that one must look for the incipient syntheses of early life, and the introduction of land or sea bottom within the photic zone will lead to the progression of attached organism (hormon) which responds to the more elaborate factors of water plus substratum. With the assumption of a sessile habit on the part of originally free zooids of the plankton, the attached plant or animal proceeds to a benthic phase of existence, and in the case of autotrophic zooids it begins to be possible to define the scope of algology. The cell soma becomes enlarged and multiple as it successfully solves the problem of increased nutrition by a surface area exposed to a medium which is constantly renewed so long as the capacity for attachment is unimpaired. As opposed to the successful detachment of predatory animal organism (nekton), the detached autotrophic plant fails from impoverished nutrition. The development of the algal soma thus follows the infinite series of compromises between maximum surface for nutrition and minimum exposure to mechanical strain, from quiet dark levels to illumined surface-zones of rough water, giving rise to morphological differentiation of branching axes, growing points, laminar extension, and ultimately to massive highly differentiated shoot-systems with ramuli subserving attachment which come within the more popular connotation of plant-form. In all such cases, however, exigencies of racial continuation imply a resumption at some period of the older plankton-soma, and in this phase phenomena of sexual fusion may be maintained; to attain a more complex differentiation (sex-distinction) as the wastage of protoplasts in regaining the sessile condition, on a substratum increasingly occupied in a violently agitated medium, may be brought under control. The development of algal form and volume commonly runs parallel with increasing specialization of sexual and asexual reproductive mechanism. The latter implies that a cytological alternation may be requisite in the life cycle. Highly specialized growth-forms of the benthic soma of autotrophic plants parallel the equally advancing benthic somata of holozoic nutrition (sponges, hydroids); and in both very comparable differentiations of sexual cells, sexual organs, and the retention, at any rate on the part of the male gamete, of an older flagellated soma illustrate the parallelism of the biological problems.

From such highly organized somata of the sea the flora of the land takes origin, both as compulsory transmigrants on the first exposed land-surfaces, and as left residual in water now renewed by atmospheric precipitations as "fresh," and devoid of much of the essential food salts. Starvation in fresh water and desiccation on dry land become the determining factors of all advancing land-vegetation; though in the case of the latter the implied light-supply may be far in excess of older photic relations, as the oxygen capacity of the atmosphere again is beyond the available free supply of the water. The insistent problems of the land plant are mechanical support and orientation in the lighter medium of the air, protection from extreme loss of water, absorption and conduction from an attachment-surface following separation of the absorptive and photosynthetic tracts, and the adjustment of older reproductive organs to the exigencies of dispersal by air-currents instead of by moving water. In this way the inherited equipment of the algal soma is specialized and amplified to meet the new requirements. An epoch in which such natural selection may be rigorous over long-continued ages of slow progression and regression, has been visualized as a period of "Transmigration," effected *in situ*, as the sea-bottom may be partially exposed or again covered by oscillating changes in the earth's crust over geological epochs, as the net result of foldings of the surface-layers. Older laminar ramuli of algae attain further

elaboration of mechanism, orientations, and anatomy as "leaves"; attachment-ranuli exaggerate their absorbing function as they penetrate massed decaying material, now for the first time associated with minute heterotrophic organisms as bacteria, constituting the first soil. Internal and effete cell-units storing waste polysaccharide of photosynthesis are utilized as mechanically supporting fibres, others from a water-storing function attain a conductive significance as tracheides; intercellular spaces are elaborated in connexion with a transpiration mechanism which now becomes the only means of obtaining food-ions of inorganic nature. Most remarkably and constantly the asexual spore-tetrads, following meiosis in an asexual generation (as in *Dictyola* and *Florideae*), are utilized as air-borne spores; while the sexual gametes retain their older plankton mechanism of sexual fusion in an aqueous medium, so far as this may be available. From such beginnings arise the Bryophyta (Mosses) in which fertilization *in situ* is associated with the more or less complete parasitic decadence of the spore-producing generation, and the Pteridophyta (Ferns), in which great perfection of the free asexual land-plant is associated with a sexual phase reduced to a mere protonema stage with precociously effective sexual organs, correlated with a minimum period in which the necessary water may be available; and sori of tetraspores are adapted to a sporangial mechanism which will dehiscence in the air.

No plant-phylum which had not previously attained to a two-phase cycle has made good on the land; since following the attainment of fertilization *in situ* the asexual species of the complementary generation or "person" were required for a dispersal function. Higher types of land-vegetation follow the Pteridophyte progression, passing on to the evolution of the seed-habit as Spermatophyta; in so doing expressing the successful method of evading problems of the utilization of free external water for the plankton process of fertilization. Much residual algal life of simple category persists as heterotrophic races of fungi, in which the problem of aquatic cross-fertilization is largely solved by eliminating it altogether, or retaining mechanism in the merest vestigial expressions. Suggestions as to the time involved in such evolutionary progression have been emphasized by data for the decay of radio-active minerals, as affording a time-chart by means of which geological epochs may be approximately estimated. The datum of 300 million years for the Carboniferous and Devonian, in which forest-trees of coniferous habit are known to have existed, as also the *Rhynia* group of the Lower Devonian which may express extreme types of Pteridophyta or limiting cases of Bryophyta, appears but of small value in the evolution of such high-grade land organisms as timber-trees from mere marine algae. A general estimate of 2,000 million years for the first stages of transmigration may not appear excessive; and behind this stretches the indefinite range of the evolution of the algal series, to the more remote epochs of the plankton-phase of the evolution of the cell in all its manifold possibilities and controlling functions, from the material of sea water alone. Yet in these respects there can be little doubt that the autotrophic plant, as the sole response of what is termed life to the biological factors of ancient seas, is more likely to be a sure guide to the history of the more modern world than any biologically unsupported and equally fragmentary testimony of the rocks. From the standpoint of conventional views of "descent" the story of evolution now becomes the history of biological and physiological progression to higher horizons as determined by changes in the condition of the external environment, of which residual plant-groups, each as absolutely cut off behind as non-progressive in other respects, remain as "Landmarks of Limitation" to point the way the progression has passed, as wholly isolated genetically as if the independent creations of an older philosophy, yet all meeting in the phase of the common initial medium of the sea.

See Bower, *Origin of a Land Flora* (1908); Doflein, *Protozoenkunde* (1916); Pascher, *Archiv für Protistenkunde* 36 (1917); Kidston and Lang, "*Rhynia*," *Hornea*," *Trans. Roy. Soc. Edin.* (1920); Church, "Building of an Autotrophic Flagellate," *Thalassophyta and the Subaerial Transmigration*, *Oxford Botanical Memoirs*, I (1919); "Somatic Organization of the Phaeophyceae," *ibid.* 10, (1920); Arber, *Devonian Floras* (1921). (A. H. CH.)

IX. *Anatomy and Palaeobotany*.—Progress in anatomical, and in palaeobotanical Botany essentially go hand in hand. The discoveries of well-petrified new forms of fossil plants, which are often difficult of identification, lead to more critical examination of the structure of recent plants, and thus bring to light interesting features in the latter. Yet both the methods pursued and the type of material available for the botanist and palaeobotanist tend to differ. Knowledge of the anatomy of the fossil *Angiosperms*, for instance, has been naturally restricted owing to the scarcity of material other than of Tertiary age; while the isolated fragments of Tertiary wood have not attracted any particular attention in recent years, largely owing to the difficulty of mastering the overwhelming mass of living species with which they have to be compared. The origin and phylogenetic

source of the *Angiospermic families* is thus still wrapt in mystery in spite of various theoretical conceptions. The only secure fact is that in geological time corresponding to the Wealden in Great Britain, and approximately to the Neocomian of the world, no reliable material of *Angiosperms* of any sort has yet been discovered. Claims to have identified *Angiosperms* in these or earlier rocks are not substantiated, and originated from such errors as incorrect diagnosis of ferns possessing reticulated venation like *Dictyophyllum* (see exposures by Berry, 1911, and Stopes, 1915).

The earliest authentic *Angiosperms* are found in the Lower Greensand or Aptian of Great Britain. The flora of this epoch was markedly distinct from that of the Wealden, which is of the Jurassic type; that of the Lower Greensand, on the contrary, was a rich, mixed flora, including many varieties of coniferous woods, the famous *Bennettites Gibsonianus* described by Carruthers, and other *Bennettitales* plants, and, in particular, several *Angiospermic woods*. The systematic position of these *Angiosperms* is scarcely determinable, owing to the fact that modern plant anatomists have not yet codified the significance of woody structures in the living genera in spite of the extensive beginning made by Moll and Jannitsch. The petrified features of the ancient genera *Cantia*, *Woburnia*, *Sabulisa*, *Aptiana* and *Hythia* are in no way "primitive" or pseudo-*Angiospermic*, but exhibit typical features of highly organized *Angiospermic* timbers. Hence the origin of the *Angiosperms rossianus* obscure, and a problem to be solved only by the discovery of the anatomical features of *Angiosperms* of an even earlier age.

The American school headed by Jeffrey, although contributing little to the description of new fossil *Angiosperms*, has worked on the problem of their descent on the basis of a series of well-defined theories. Jeffrey's main thesis is that the herbaceous forms are less primitive than the woody, and "the degenerate herb is derived from ancestral forms characterized by woody stems." While Jeffrey's conclusions and deductions are not universally accepted, workers of his school have contributed handsomely to the accumulation of data from living forms, and his text-book of anatomy attempts to bring out guiding principles, chief among which is the "Doctrine of Conservative Organs," springing from Scott's observations on the Cycadales, and the "Doctrine of Reversion." In Britain no comprehensive theoretical work on general anatomy has appeared recently. The anatomy of seedlings has been pursued (Hill and Thomas), but, unfortunately, has no corresponding development in palaeobotanical works owing to their tenuous rarity.

From rocks of Palaeozoic age onwards, well-petrified *Gymnosperms* are constantly being discovered, and the study of their structures has necessitated the reexamination of all the modern genera. A steady output of memoirs dealing with the anatomy of living and fossil gymnosperms has been maintained (see in particular the works of Seward, Groom, Stopes, Gothan, Thomson, Hollick and Jeffrey, Coulter and Chamberlain, and others). While the English school have in the main added wherever possible new data on the recognized accepted lines of the generic grouping, Americans under Jeffrey have actively maintained the broader view, that the Araucariaceae are less primitive than the Abietineae, basing most of their generalizations on the minutiae of tracheid structure, which appeared clearer and more dogmatic guides so long as comparatively little was known of the infinite variety of the Mesozoic forms, but which have become self-contradictory as generic or even specific diagnostic features when such a wealth of material as is now available has been examined.

The primitive Palaeozoic gymnosperms are gradually becoming very well known from the relative frequency with which their stems, leaves and other parts are found petrified. The most notable recent addition to the group is the exceptional little flora of plants from the very base of the Carboniferous of Kentucky (see Scott and Jeffrey) which bears considerable likeness to the primitive Saaleffloras described long since by Unger.

Anatomical work on the large group of the *Bennettitales* (which became entirely extinct before the Tertiary period) has yielded results of morphological and phylogenetic importance, and enriched general concepts of fructification and seed structure. Such work, initiated in 1870 by Carruthers, with his acute determination of the type fossil, remained for long in abeyance owing to the dearth of material in Britain, but was continued on the Continent in the last decade by Lignier and recently in England by Stopes. Studies on this group were actively pursued in America by Wieland, the main results of which are collected in his two magnificent volumes *American Fossil Cycads*, from which the diagrammatic restoration of the peculiar fructifications and many interesting points of vegetative anatomy have proved a mine of information for theorists. The view that the *Bennettitales* were ancestral *angiosperms* was, temporarily at any rate, held by a number of leading botanists and received definite expression by Arber and Parkin. This view, however, is not built on a sufficiently secure anatomical foundation. The vascular peculiarities and vegetative appearance of the *Bennettitales* are so closely allied to those of Cycads still living that their complex gymnospermic fructifications are best looked upon as no

more than a specialisation on "prophetic" lines by a cohort which became extinct, comparable to another specialisation in another family in an earlier epoch, viz. the "seed-like" structures of the tree forms of the Lepidodendrons, which though truly Lycopodiaceae, developed "seeds." Another branch of the great Mesozoic group, the Williamsoniaceae, may prove to be better accredited forerunners of some angiospermic cohorts. The small form *Williamsoniella*, described by Thomas from the Jurassic, has an interesting and suggestive morphology. Anatomical work on the genus, however, still awaits the discovery of suitably preserved material.

Interest in the Cycads proper, stimulated in the preceding decade, has been continued. Their fructifications and general anatomy have been, searchingly examined for primitive features (Matto, Stöpes, Chamberlain, Seward, Worsdell), but still remarkably little is known of the geological history or early structure of the Cycads proper.

Anatomical work on the *Pteridophytes* has made steady progress, as is evidenced by the considerable enlargement of the first volume of the new edition of Scott's classic "Studies." Data of interest to anatomists have been chiefly based on Coal Measure species, filling in supplementary details in previously well-established schemes. The most important contribution in this connexion has been the thorough handling of the Osmundaceae, made possible by discoveries of well-petrified Mesozoic and Tertiary species (see in particular the series of Memoirs by Kidston and Gwynne-Vaughan). From an anatomical study of a series of species, the authors were able to present a phylogenetic sequence in the evolution of the family from Palaeozoic times, and held that the group arose from solid protostelic ancestors. Their view has been substantiated by a recent discovery of a true protostelic Osmundacean form. The Botryopteridae, with their intricate series of stelar variations continued to receive detailed consideration (see Bertrand, Scott, Zalesky, Gordon and others) in the last decade, and are now very thoroughly known. A fern of wide geological distribution and of peculiar anatomical structure was at last made clear by the work of Kidston and Gwynne-Vaughan on *Tempskya*. Access to the original paper published in Russia is difficult and reference should also be made to Stöpes, 1912. The work of Schone on the branches of the Pteropsida should be read in connexion with *Tempskya* which had an extraordinary, massive tree-fern-like trunk, really built up of a web of fine selenostelic stems, petioles and roots. Although anatomical work (by Tansley, Lang, Seward and others) has been done on various genera of recent forms, good petrified material from the Mesozoic or Tertiary is either very scarce or has not received that anatomical attention which makes it possible to demonstrate the phylogenetic series connected with the higher families of recent ferns, such as Kidston and Gwynne-Vaughan have presented for the Osmundaceae. Yet where anatomical studies have been undertaken on recent genera, as by Lang on the Ophioglossaceae, they are largely influenced by the general principles of palaeobotany and the theme (as a sort of *leit-motif*) of the solid ancestral stele, runs through such work.

Of the lower Pteridophytes, our knowledge of those impressive members of the Lycopodiaceae, the Lepidodendroid series, was already essentially established, and in the last decade has merely received detailed amplification.

In the more primitive groups, however, great advances have recently been made through the active interest taken in the Devonian flora by Halle of Norway, who described the morphology and part of the structural details of a number of noteworthy species. This was soon followed by Kidston and Lang, to whom were entrusted the plant materials of the now famous *Rhynia* cherts. The *Psilophytus* of Dawson, so long relegated to insignificance and by many considered to represent merely imperfect fragments, has thus suddenly become of great interest. In the Scottish cherts are well-petrified genera whose anatomy shows very much the type of structure postulated so long before by Dawson. *Sporangites* of Halle, *Rhynia*, *Hornua*, *Asteroxylon* of Kidston and Lang represent the earliest known land plants, and though varying in details, all show a remarkable simplicity of structure and arrangement of their aerial stems and terminal sporangia. These plants are stimulating discussion on the origin of land plants, the evolution of the Pteridophytes from the lower groups, and the morphology of the various organs in higher plants, and their anatomy is of deep morphological and phylogenetic significance.

Anatomical work on the *Bryophytes* still has to confine itself to living forms because fossils are almost non-existent. Various features of the last-described group of new fossils, however, are highly suggestive for those who consider the phylogeny of the mosses. That isolated family, the Characeae, is well represented in many deposits, and has been seriously taken in hand by Reid and Groves with full examination of the anatomy of many beautiful fossil forms.

In palaeontological as in modern anatomy, observation is generally concentrated on the vascular tissues, and particularly on the arrangement and character of the wood. This leads not infrequently to difficulties for the palaeobotanist, who sometimes finds in his specimens other portions of plants which are difficult to diagnose owing to the practical neglect of the comparative study of such organs by recent botanists. For instance, especially since the "clearing method" was popularized by Nathorst, the study of the "mummified" cuticles from fossils of all kinds has brought

into prominence the general ignorance concerning the diagnostic value and main characters of the stomata and epidermal cells among recent plants. The palaeobotanist, therefore, has had to investigate groups of living forms to effect his own comparisons. This in small genera of gymnosperms has not been crushingly burdensome, and has resulted in considerable additions to our knowledge of the details of recent forms (see Berry, Halle, Thomas, Bancroft, Antev and others). But for workers among the more extensive families of recent angiosperms, comparisons have become overwhelmingly arduous. Recognition of the "mummified" or semi-preserved seeds of angiosperms found in Tertiary deposits has become a work of the highest specialization in the hands of Mr. and Mrs. Clement Reid, who have greatly extended our knowledge of recent deposits, both in England and on the European Continent.

In the above paragraphs the more botanical and phylogenetic aspects of plant anatomy have been considered. But the palaeobotanist has other functions, and he finds wider fields of application for an anatomical knowledge of fossil species. The value of the anatomical structures of the leaves, stems and so on of fossils of given localities and epochs in determining the nature of the climates of the past has long been recognized, and in the last decade this subject has chiefly been pursued by Berry in America, who has extensively surveyed the Upper Cretaceous and Tertiary climates and distribution of species. In the southern hemisphere, that "terra incognita," the Antarctic, has been a little illuminated by the collections (see Seward and others) brought back by the Scott expeditions. And Gothan has worked on the woods from the Arctic.

A specialized application of anatomical knowledge has developed in connexion with a detailed study of coal. Many of the earlier workers (Dawson, Williamson, Huxley and others) were interested in the spores and small structures to be seen in coal and in recent years section cutting has been improved by Lomax, who has demonstrated many beautiful structures in coal sections. More exact consideration of the relation of the different parts of the plants to the character and accumulation of different types of coal in conjunction with their chemical analyses, ash content and so on has recently been made by Stöpes, Stöpes and Wheeler, followed by Lessing, Tideswell and others. The detailed chemistry of the different cell units composing the plant body is now gradually being correlated with the qualities of the different fractions of a band of coal. The resistant properties of certain cells such as spores and cuticles (yielding fuels of peculiar types on a big scale such as the "Cuticle Coal" of Russia) are being followed up on a minuter scale in the fine zones in an ordinary band of British coal, which have been shown to contain correlated differences, both in the anatomical nature of their plant content, their physical and chemical properties, the nature of their ash and so on.

The bibliographies in the following books will give most of the references, except those of monographs published quite recently:—E. W. Berry, *Lower Cretaceous Deposits of Maryland* (1913), and *Upper Cretaceous and Eocene Floras of South Carolina and Georgia* (Washington, 1914); J. M. Coulter and C. J. Chamberlain, *Morphology of Gymnosperms* (Chicago, 1910); E. C. Jeffrey, *The Anatomy of Woody Plants* (Chicago, 1917); D. H. Scott, *Studies in Fossil Botany*, ed. 3 (London, 1920); A. C. Seward, *Fossil Plants*, vol. iii. (Cambridge, 1917); M. C. Stöpes, *Catalogue of the Cretaceous Plants in the British Museum*, vol. ii. (London, 1915); M. C. Stöpes and R. V. Wheeler, *The Constitution of Coal* (London, 1918); G. R. Wieland, *American Fossil Cycads*, vol. ii. (Washington, 1916). (M. C. S.)

**X. Cytology.**—Great advances have been made in the study of cytology, but considerable divergence of opinion still exists with regard to many details of nuclear phenomena (see also the separate article CYTOLOGY).

The discrepancies and contradictions present in the accounts of *mitosis* are due to the fact that no animal or plant has been found in which all of the phases connected with nuclear division can be elucidated. Each form has individual cytological characters, and its nuclei may show some stages with exceeding clearness, whilst others may be disguised or apparently even eliminated. The true version will only be attained by wider comparative investigations.

(1) *Somatic divisions* (fig. 1). Most cytologists agree that, as a rule, during telophase each somatic chromosome splits into longitudinal halves (threads), and these halves tend to separate, forming more or less of a reticulum, according to the degree of interkinetal rest assumed by the nucleus. The prophase stages are interpreted in two ways (a) that the pairing of threads in the prophase is the reassociation of the chromosome halves which separated during the preceding telophase, that these gradually come together to form the univalent chromosome, and separate as daughter chromosomes on the ensuing spindle; (b) that the pairing of threads and the splitting of the univalent chromosomes into daughter halves are purely prophase phenomena and bear no relation to the splitting of the chromosomes in telophase. (Fraser and Snell 1911, Müller 1921, Grégoire 1912, 1913, Sharp 1913, Digby 1919.)

(2) *First Meiotic division*. Controversy rages over the mode of

origin of heterotype chromosomes. The differences between the two schools of thought ("telosynaptists" and "parasyntaptists") rest on the interpretation of the heterotype prophase (Farmer 1912) (fig. 4). Telosynaptists regard the paired threads of the

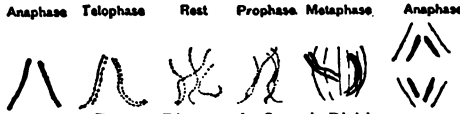

FIG. 1.—Diagram of a Somatic Division.

presynaptic and synaptic phases (fig. 2) as the associating halves (homologous with the threads of the somatic prophase) of a somatic chromosome which separated during the preceding telophase, and maintain that the conjunction of the two entire homologous somatic chromosomes takes place prior to, and during second contraction (fig. 3). Consequently the associating threads of synapsis only separate as daughter chromosomes on the homotype (2nd meiotic) spindle.

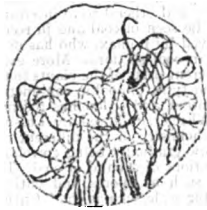

FIG. 2.—Synapsis (*Osmunda regalis*) (After Grégoire) (From *La Cellule*, vol. XXIV.)



FIG. 3.—Second Contraction (*Smilacina*) (After Lawson) (From *Trans. Roy. Soc. Edinburgh*, vol. XLVIII.)

"Parasyntaptists" (Grégoire's school), on the other hand, regard the parallel threads of the presynaptic and synaptic prophase (fig. 2) as the pairing of two entire homologous somatic chromosomes which will separate on the heterotype (1st meiotic) spindle. They attach no significance to the second contraction phase. (Stomps 1911, Davis 1911, Lawson 1912, Grégoire 1912, Fraser 1914, Notherg 1916, Digby 1919.)

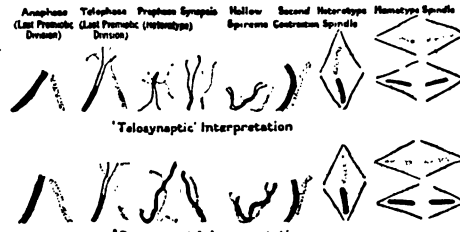

FIG. 4.—Diagram of Meiotic Phase.

The doctrine initiated by Boveri concerning the individuality of chromosomes is now widely supported. It is based on three main facts: (a) the continuity of chromosomes can sometimes be traced from telophase into the ensuing prophase, especially in rapidly dividing tissues; (b) the specific number of chromosomes, in any given animal or plant, recurs at each mitosis with extraordinary regularity.<sup>1</sup>

Tischler (1915) and Ishikawa (1916) have collated the numbers recorded in plants: (c) chromosomes with striking individual characters of size and shape, distinguishing them from others in the nucleus,

<sup>1</sup>The number of chromosomes is inconstant in degenerating tissues such as endosperm and tapetum; nuclei with a double number may

occur in many animals and plants. These characteristic chromosomes invariably reappear at every mitosis.

Recently much attention has been given to the significance of specific numbers of chromosomes. It has been conclusively shown that closely allied species of many families have related chromosome numbers, i.e. multiples of a common factor. Thus diploid, triploid, tetraploid,<sup>2</sup> etc., forms are distinguished (Marchal 1912, Gregory 1914, Winge 1917, Holmgren 1919, Kuwada 1919, Rosenberg 1920). This multiplication of chromosomes may prove to have an important bearing on mutation, e.g. *Primula sinensis* 12 (haploid number), *P. sinensis* (giant) 24 (haploid number), *Crepis virens* 3 (haploid number), *Crepis tectorum* 4 (haploid number), *Crepis rubra* 5 (haploid number), *Oenothera Lamarckiana* 7 (haploid number), *O. gigas* 14 (haploid number) (fig. 5).



FIG. 5. *Oenothera Lamarckiana* (7 pairs of chromosomes) (Interkinesis between Heterotype and Homotype Mitoses) (After Davis) *Oenothera gigas* (14 pairs of chromosomes) (From *Ann. of Bot.*, vol. XXV.)

As regards dimensions, the width of chromosomes, both in animals and plants, is inconstant and more or less variable, and is in no way correlated with phylogenetic affinity (Farmer and Digby 1914). Among other points of importance, recent work on hybrids (Rosenberg 1917) confirms previous observations, that the offspring of parents with an unlike number of chromosomes show irregular meiotic divisions. The classical experiments of Némec who, by submitting root tips to the action of chloral hydrate, produced multinucleate cells and abnormal mitoses, have been extended (Sakamura 1920). Extrusion of particles of nuclear substance, especially as globules from the nucleolus, has been repeatedly observed in animal and plant cells (fig. 6); this phenomenon probably denotes some important physiological interchange between nucleus and cytoplasm (von Derschau 1915 and 1920).

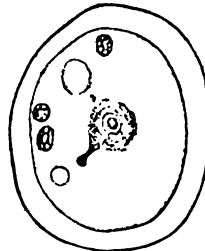

FIG. 6.—Extrusion of Nuclear Substance (*Funaria hygrometrica*) (After von Derschau) (From *Archiv für Zellforschung*, vol. XIV.)

Many authorities believe that chromosomes determine the segregation of Mendelian characters and that mitosis provides precisely the mechanism required. Gates and Thomas (1914) have shown that these *Oenothera* mutants *lata* and *semilata*, which possess an extra chromosome, i.e. 15 instead of 14 (somatic number), always have a characteristic type of foliage and habit (fig. 7).

**Bibliography.**—Two new text-books have been published (Agar 1920, and Doncaster 1920), and Wilson's *Cell* has been reprinted (1919). On special points, the following may be mentioned:—Davis, "Cytological Studies on *Oenothera* III. A Comparison of the Reduction Divisions of *Oenothera Lamarckiana* and *O. gigas*," *Ann. of Bot.* (1911, vol. XXV.); von Derschau, "Der Austritt ungeladener Substanz aus dem Zellkerne (Eine zusammenfassende Studie)," *Archiv f. Zellforschung* (1915, vol. XIV.); "Pflanzliche Plasmastrukturen und ihre Beziehungen zum Zellkern," *Fleiss* (1920, vol. XIII.); Digby, "On the Archeposporial and Meiotic Mitoses of *Osmunda*," *Ann. of Bot.* (1919, vol. XXXIII.); Farmer, "Telosynapsis and Parasyntapsis," *Ann. of Bot.* (1912, vol. XXVI.); Farmer and Digby, "On Dimensions of Chromosomes considered in relation to Phylogeny," *Phil. Trans. Series B.* (1914, vol. CCV.); Fraser, "The Behaviour of the Chromatin in the Meiotic Divisions of *Vicia Faba*," *Ann. of Bot.* (1914, vol. XXVIII.); Fraser and Snell, "The Vegetative Divisions in *Vicia Faba*," *Ann. of Bot.* (1911, vol. XXV.); Gates and Thomas, "A Cytological Study of *Oenothera* mut. *lata* and *Oe* mut. *semilata* in Relation to Mutation," *Quart. Journ. Micr. Sci.* (1914, vol. LIX.); Grégoire, "Les Phénomènes de la métaphase et de l'anaphase dans la carvocrinée somatique," *Ann. Soc. Scientif. de Bruxelles* (1912, vol. XXXVI.); "La vérité du

occur in root tips (Strasburger 1911).

<sup>2</sup>Winkler (1920) has produced tetraploid forms artificially.



phéase hétérohomotypique," *Comptes Rendus* (1912, vol. CLV).  
La télophase et la prophase dans la caryocinèse somatique,

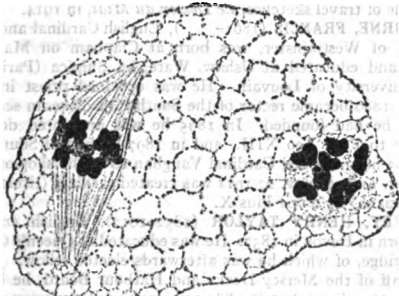

FIG. 7.—*Oenothera lamarckiana*.  
(Homotypic division. Distribution of chromosomes)  
(After Gates and Thomas)  
(From *Quart. Journ. Micr. Sci.*, vol. LIX.)

*Comptes Rendus* (1913, vol. CLVI); Gregory, "On the Genetics of Tetraploid Plants in *Primula sinensis*," *Proc. Roy. Soc. B.* (1914, vol. LXXXVII.); Holmgren, "Zytologische Studien über die Fortpflanzung bei den Gattungen *Erigeron* und *Eupatorium*," *Swenska Vetensk. Akad. Hand.* (1919, vol. LIX.); Ishikawa, "A List of the Number of Chromosomes," *Bot. Mag. Tokyo* (1916, vol. XXX.); Kuwada, "Die Chromosomenzahl von *Zea Mays* L.," *Journ. Coll. Sci. Imp. Univ. Tokyo* (1919, vol. XXXIX.); Lawson, "A Study in Chromosome Reduction," *Trans. Roy. Soc. Edinburgh* (1912, vol. XLVIII.); Marchal, "Recherches cytologiques sur le genre 'Amblystegium,'" *Bull. Soc. Royale Bot. de Belgique* (1912, vol. LI.); Müller, "Kernstudien an Pflanzen," *Archiv. f. Zellforschung* (1912, vol. VIII.); Nothnagel, "Reduction Divisions in the Pollen Mother-cells of *Allium tricoccum*," *Bot. Gaz.* (1916, vol. LXI.); Rosenberg, "Die Reduktionstellung und ihre Degeneration in *Hieracium*," *St. Bot. Tids.* (1917, vol. XI.); "Weitere Untersuchungen über die Chromosomenverhältnisse in *Crepis*," *St. Bot. Tids.* (1920, vol. XIV.); Sakamura, "Experimentelle Studien über die Zell- und Kernteilung, mit besonderer Rücksicht auf Form, Grösse und Zahl der Chromosomen," *Journ. Coll. Sci. Imp. Univ. Tokyo* (1920, vol. XXXIX.); Sharp, "Somatic Chromosomes in *Vicia*," *La Cellule* (1913, vol. XXXIX.); Stomps, "Kernteilung und Synapsis bei *Spinacea oleracea* L.," *Biol. Centralbl.* (1911, vol. XXXI.); Strasburger, "Kernteilungsbilder bei der Erbsen," *Flora* (1911, vol. CII.); Fischer, "Chromosomenzahl-, form- und individualität im Pflanzenreiche," *Progr. Rei. Bot.* (1915, vol. V.); Wince, "The Chromosomes: Their Numbers and General Importance," *C. R. des Travaux Lab. Carlsberg* (1917, vol. XIII.); Winkler, "Über die experimentelle Erzeugung von Pflanzen mit abweichenden Chromosomenzahlen," *Zeit. f. Bot.* (1916, vol. VII-VIII). (L. D.)

**BOTHA, LOUIS** (1862-1919), Dutch South African statesman (see 4.303). The intention which Botha declared during his visit to England in 1907—to work for the welfare of South Africa regardless of racial differences—he subsequently carried out to the full. It became the main object of his life. During the Imperial Conference of 1907 Botha met Dr. (later Sir Starr) Jameson for the first time; at least there is no known record of any earlier meeting between the two men. Their meeting was destined to have momentous results for South Africa. They became close friends. Already in the minds of both there must have been the belief that the true interests of the country demanded union between the four colonies, Cape Colony, the Transvaal, the Orange River Colony (as it had been called since the South African War), and Natal. The belief was gaining ground, and in 1909 it took shape in the calling of a National Convention to form a scheme of closer union. Botha led the Transvaal delegation; Jameson that from the Cape. As the two leading colonies, the Cape and the Transvaal had on the whole the decisive voice in the Convention.

Botha's personal share in the work of the Convention was important. It confirmed the opinion, already strong in South Africa, that Botha was the natural leader of the South African Dutch, and had qualities of personality and statesmanship which marked him out as the inevitable man to be first Prime Minister of a united country. Botha's qualities were put to a

severe test while the Convention sat. Then, and when the Union Act had been framed and he went with the South African delegation to England to see it through Parliament, Botha gave proofs of steady wisdom, self-control, and a far-sighted patriotism. Thus, when the Union was inaugurated by the first Governor-General, Lord Gladstone, in 1910, it was with the approval of the great majority of South Africans that Lord Gladstone summoned him as Prime Minister to form the first South African Cabinet.

Suggestions had been made that the first Union Ministry should be formed of both the principal parties in the old colonies. Botha rejected these proposals, though it was believed at the time that they appealed to his personal desires. His Ministry represented, in the great majority of its members, the Dutch of South Africa and the political parties in the old colonies to which they adhered, though it included a representation of the English-speaking people of Natal. Botha had decided that to form what was known at the time as a "Best Man" Government would be to invite a fatal reaction towards crude racialism among the mass of the South African Dutch. Nevertheless the reaction came, for all his attempts to avoid it, before his Cabinet had been in office even for half of its term of five years. It came in the form of a revolt against his moderation and his attempts to hold the balance even as between English and Dutch. The revolt was led by General Hertzog, and caused a split in the Ministry and the dismissal of Hertzog in Dec. 1912. Botha reformed his Ministry, again without the inclusion of any members of the Unionist party—representing, with account taken of the influence of the Labour party in the cities, the English-speaking population.

In 1914 came the World War. Botha at once declared himself for Great Britain, prepared an expeditionary force against the neighbouring German colony of South-West Africa, and had landed his first detachments upon its coast when a rebellion of the Dutch flared out behind him in the Transvaal and the Orange Free State, whose old name had been restored by the Act of Union. Botha took the field himself, crushed the rebellion by a series of rapid thrusts, went himself to German South-West Africa and completed the conquest of that country, and then organized both a force to assist in the British invasion of German East Africa and an expeditionary unit to fight for the Allies on the western front in Europe. These achievements were made possible by a decisive victory at the polls in 1915 and by the steady coöperation of the Unionist party in Parliament. When Mr. Lloyd George became Prime Minister of Great Britain at the end of 1916 and summoned the Imperial War Cabinet, Botha found his South African preoccupations too heavy to allow him to attend it; but he sent in General Smuts his *alter ego*, whose abilities, insight and cool judgment were invaluable to the British Government. Smuts became the single permanent dominion member of the Imperial War Cabinet, but his absence from South Africa threw a vast burden of work on Botha as Prime Minister. Botha found time to come to Europe to represent South Africa at the Paris Peace Conference, where his wisdom and sound judgment increased a European reputation already equal to that of any other dominion Prime Minister. He did not approve of many of the terms of the Peace Treaty, and did not hesitate to say so. But he was in full accord with the development in British institutions which accorded to the dominion representatives in Paris the status of delegates from self-governing States equal in nationhood to the other Powers, and upon this development he insisted repeatedly after his return to South Africa. He died very soon after his return. His health had been failing for some time. Influenza attacked him, and at midnight Aug. 27-28 1919 he succumbed to heart failure resulting from it.

To his country Botha's death was an irreparable loss. He had attained an influence there, unprecedented even when the disposition of the Dutch South African to give his heart to trusted leaders is taken into account. He had won the devotion of the English-speaking people of the country as no other leader of Dutch birth had been able to win it. The native population



believed in him and trusted him. Simple, modest, without personal ambition, he had yet the greatest gift in a national leader, personality. His kindness was transparent, his temperament always inclined to compromise, his mind naturally impartial. In small things he inclined too often to give way. But in the big things his discernment of principle was unerring, his resolution adamant. Greatness was his by right of nature, a greatness recognized and acclaimed in his last years by the world no less than by his own countrymen. (B. K. L.)

**BOURASSA, HENRI** (1868— ), French Canadian politician, was born in Montreal Sept. 1 1868, his mother being a daughter of L. J. Papineau. He became well known at a comparatively early age as an active writer and speaker on the side of the Nationalist movement in Canada, and a leader of the younger school of French Canadians. He was elected to the Dominion House of Commons in 1896, but resigned in protest against Canadian participation in the S. African War, 1899; he was re-elected, however, in 1900 and in 1904. He was a member of the Quebec Legislative Assembly in 1908-12. A gradual severance took place between him and his old chief, Sir Wilfrid Laurier, until in later years he became obsessed with the idea that Laurier's policy was fatal to the best interests of Canada and especially to Quebec. A speaker of extraordinary power and fascination, both in Parliament and on the platform, even Laurier himself could not sway the French Canadians as Bourassa could, and in spite of his extreme views he was heard with respect even in the strongholds of his opponents in Toronto.

**BOURCHIER, ARTHUR** (1864— ), English actor (see 4.329), produced in 1910 *Henry VIII.* and *Macbeth* at the Garrick theatre, London, and in the same year joined Herbert Tree at His Majesty's theatre, where both he and his wife played again in these and other Shakespeare plays. He also played Iago to Mr. Matheson Lang's Othello in 1920. After the dissolution of his earlier marriage with Miss Violet Vanbrugh he married in 1918 Miss Kyrle Bellew, with whom he continued to appear in modern melodrama. He acted Old Bill in Capt. Bainsfather's war play *The Better 'Ole* (1917).

**BOURCHIER, JAMES DAVID** (1850-1920), British publicist, who came of a good Irish family, was born at Bruff, co. Limerick, Dec. 18 1850. He was educated at Trinity College, Dublin, and King's College, Cambridge, and afterwards was for some years an assistant master at Eton. Subsequently joining the staff of *The Times*, in 1888 he went as special correspondent of *The Times* to Rumania and Bulgaria, and for nearly 30 years he was its principal representative in south-eastern Europe. In this capacity he established a unique authority for information on Balkan affairs, and was in the confidence of the leading statesmen. He played an important part behind the scenes in the formation of the Balkan League (1911-2); and though from time to time his advice to one party or another proved unpalatable, his disinterestedness was always as unquestionable as his accurate knowledge of the political issues involved. In the later years before the World War his prepossessions were somewhat markedly on the side of Bulgaria, and even during the war his sympathies were with Bulgaria as a country. He died at Sofia, Dec. 30 1920, and was given a public funeral there. Besides his contributions to *The Times* he was the author of many review articles, and also of the general articles, historical and descriptive, on the different Balkan States and Greece in the 11th Edition of this Encyclopædia.

**BOURGOIS, LÉON VICTOR AUGUSTE** (1851— ), French statesman (see 4.330), became minister without portfolio in the Briand Government during the World War. He took an active interest in the movement for a League of Nations, was appointed to draft its statutes and became president of the French section. He was elected president of the Senate in 1918.

**BOURGET, PAUL CHARLES JOSEPH** (1852— ), French novelist and critic (see 4.331), published after 1910 several new novels, including *La Vie passée* (1910), *Le Sens de la Mort* (1915), *Lazarine* (1917), *Némésis* (1918), and *Laurence Albani* (1920), as well as three volumes of short stories and two plays, *La Baricade* (1910) and *Le Tribunal* (1912). Two other plays, *Un Cas de*

*Conscience* (1910) and *La Crise* (1912), were written by him in collaboration. A volume of critical studies appeared in 1912 and one of travel sketches, *Le Démon du Midi*, in 1914.

**BOURNE, FRANCIS** (1861— ), English Cardinal and Archbishop of Westminster, was born at Clapham on March 23 1861, and educated at Ushaw, Ware, St. Sulpice (Paris) and the university of Louvain. He was ordained priest in 1884, and in 1889 became rector of the Southwark diocesan seminary which he had founded. In 1895 he was appointed domestic prelate to Pope Leo XIII., and in 1897 Bishop of Southwark. In 1903 he succeeded Cardinal Vaughan as Archbishop of Westminster, and on Nov. 27 1911 was created cardinal (titular of S. Pudenziana) by Pope Pius X.

**BOVEY, HENRY TAYLOR** (1852-1912), English engineer, was born in Devon in 1852. He was educated at Queen's College, Cambridge, of which he was afterwards elected fellow. Joining the staff of the Mersey Docks and Harbour Board, he became assistant engineer, but in 1887 was appointed professor of civil engineering and applied mechanics at McGill University, Montreal. In 1909 he was appointed to be the first rector of the Imperial College of Science and Technology in London, but ill-health obliged him to resign the post after a few months. He died at Eastbourne Feb. 2 1912.

**BOWELL, SIR MACKENZIE** (1823-1917), Canadian statesman (see 4.342), died at Belleville, Ont., Dec. 17 1917.

**BOWLES, THOMAS GIBSON** (1841— ), British journalist and politician, was born in London in 1841, and was educated at King's College, London. In 1860 he entered the Inland Revenue office, remaining there until 1868, and afterwards travelled extensively. He subsequently became connected, either as journalist or proprietor, with various newspapers, notably *Vanity Fair*, *The Lady*, and offshoots from the last-named periodical. From 1870 to 1871 he was correspondent for the *Morning Post* in Paris. He was elected as a Conservative for King's Lynn in 1892, and held the seat till 1906, when he was defeated, largely owing to his advocacy of free trade. He was elected for the same seat as a Liberal in 1910, but was unsuccessful in the second general election of that year. He became well known as an expert in parliamentary procedure and a critic on public finance. In 1916 he was elected for the southern division of Leicester. Mr. Gibson Bowles was always prominent as an opponent of any diminution of British sea power, and he published *Maritime Warfare* (1878); *Floksam and Jetsam* (1882); *Log of the Nereid* (1889); *The Declaration of Paris of 1856* (1900) and *Sea Law and Sea Power* (1910).

**BOXING:** see SPORTS AND GAMES.

**BOYLE, JOHN J.** (1851-1917), American sculptor (see 4.354), died in New York Feb. 10 1917. He was made an associate member of the National Academy of Design in 1910, and received a silver medal at the Panama-Pacific Exposition, San Francisco, 1915.

**BOYLESVE, RENÉ**, the pen-name of RENÉ MARIE AUGUSTE TARDIVEAU (1867— ), French novelist, who was born at La Haye Descartes, Indre-et-Loire, April 14 1867. He was educated at Poitiers and Tours, and afterwards adopted literature as a profession. His first work was *Le Médecin des Dames de Neans* (1896), and henceforth he wrote voluminously, publishing not only novels but many short stories. He is a close observer of the provincial society of France. His later works include *Sainte Marie des Fleurs* (1897); *Le Parfum des Îles Borromées* (1898); *L'Enfant à la Balustrade* (1904); *Le Bel Avenir* (1905); *Mon Amour* (1908); *Tu n'es plus Rien* (1917), and *Nymphes dansant avec des Satyres*, a volume of tales (1920). He was received into the French Academy on March 20 1910.

**BOYNE, LEONARD** (1853-1920), Irish actor, was born at Westmeath April 11 1853 and was educated for the army. He first appeared on the stage in Liverpool in 1870. On May 2 1874 he played John Fern in *Progress* at the St. James's theatre, London. He played the principal part in Henry Arthur Jones's *The Masqueraders* in 1894, and appeared in Pinero's *The Benefit of the Doubt* in 1895. In 1902 he made a success with Miss Marie Tempest in *The Marriage of Kitty*

(the English version of de Gréac and de Croissel's *La Passerelle*), and he toured with this play in America. Later he visited Conan Doyle's *Raffles* in the English provinces. He died in London April 17 1920.

**BOY SCOUTS.**—A brief reference was made in the article SCOUT (24.476) to the institution in England in 1908 of the Boy Scout movement. In later years it developed so strongly, both in England and in other countries, being also imitated, hardly less successfully, by that of the Girl Guides on similar lines, that its history requires fuller record.

In 1893-4, when serving with his regiment, the 13th Hussars, Sir Robert (then Lt.-Col., and later Lt.-Gen.) Baden-Powell realized that the ordinary peace training of soldiers for service in the field was not sufficiently practical, and he therefore carried out classes of training in his squadron for the men individually in scouting and campaigning. In 1897-8, having been transferred to command the 5th Dragoon Guards, he carried on similar training, but on improved lines, with a view to developing character—*i.e.* manliness, self-reliance, and reliability—as well as field efficiency since these were largely lacking in lads coming into the army from the ordinary board school. His lectures and practices were collated and published in a small book, *Aids to Scouting*.

During the South African War, 1899-1900, Maj. Lord Edward Cecil, Baden-Powell's chief staff officer, organized the boys of Mafeking as a corps for general utility on scout lines rather than those of cadets, and the experiment was an entire success. The experience showed that, if their training were made to appeal to them, boys would learn readily, and also that boys were capable of taking responsibility to a far greater degree than was generally believed, if only they were trusted. The troop was made a small unit, in order that the commander should be able to deal with each individual on personal knowledge of him, the system of patrols was instituted, of six boys under a leader. In carrying out the organization of the South African Constabulary, 1901-3, Baden-Powell employed the same principles on an extended scale. Responsibility was thus given to the junior non-commissioned officers, and emulation between the patrols produced a good spirit and a higher standard of efficiency all round. The human side was appealed to, and the men were trusted on their honour to a very large degree in carrying out their duties. Their uniform for field work was the cowboy hat, shirt, green tie, and shorts. Badges were awarded for proficiency in different lines of work.

In 1907 Sir Robert held a trial camp for scout training for boys at Brownsea I., at which he had boys of every class to experiment upon, and its results exceeded his expectations and prompted him to go on with the idea. The training was based on that which he had employed with soldiers and the constabulary, with some adaptation to make it suitable for boys, following the principles adopted by Zulus and other African tribes which reflected some of the ideas of Epictetus and the methods of the Spartans, and of the ancient British and Irish, for training their boys. He also looked into the Bushido of the Japanese, as well as the more modern method of John Founds for dealing with boys, and Jahn for their physical culture, as well as those put in practice by Sir William Smith, Seton-Thompson, Dan Beard and others. In Jan. 1908, he brought out the handbook of the training, entitled *Scouting for Boys*, in six fortnightly parts. A number of troops were started in different parts of the United Kingdom before the series was half completed. Although he had only anticipated that scouting would be taken as an additional attraction for their boys by the Boys' Brigade and Church Lads' Brigade, it became evident that a separate movement was required to deal with the number of boys who were taking it up unconnected with these bodies.

In 1910, the Boy Scout movement had grown to such dimensions (223,990) that Sir Robert felt it incumbent upon him to leave the army in order to take the movement in hand as "Chief Scout." With a view to making the subject appeal to boys, and to meet their spirit of adventure, he held up for their ideal the doings of backwoodsman, knights, adventurers and explorers, as the heroes for them to follow. These he grouped generally under the title "Scouts."

Through camp life, boat work, pioneering and nature study could be found all the attractions for a boy which at the same time would be the medium of instruction. The instruction took the form of active self-expression on the part of the boy, rather than his passive reception of ideas.

Partly from his own experience and partly from that of others, Sir Robert worked out what was lacking in the training in the average schoolboy. The deficiency lay chiefly in the direction of:—(1) Character and general intelligence; (2) skill as handicrafts; (3) physical development and health knowledge; (4) service for others and for the State. The activities and practices of scouting were, therefore, framed as far as possible to develop in (1), (2), and (3) the efficient individual, and then to harness his individuality for the good of the community, *i.e.* citizenship. Honour was made the ideal for the boys. The Scout Law, on which the movement hinges, was taken from the code of the knights.

King Edward, and later King George V., became the patron of the association of Boy Scouts, and the Duke of Connaught its president. Administration was decentralized from the Imperial Headquarters Council (at 25, Buckingham Palace Road, London) through county commissioners, district commissioners, and local associations to the scoutmasters in charge of troops.

For organization the troop was purposely kept small in numbers (40 being regarded as the best maximum), in order that the scoutmaster should have personal knowledge of each of his boys, this being the only possible way of developing the character of the individual. The patrol system was adopted from that of the South African Constabulary, and for the same reason. An extensive system of badges was instituted, as in the Royal navy and the constabulary, for excellence in different branches of work.

The Boy Scout movement is non-military, non-political, non-class and interdenominational. Its aim is to make good citizens, and for this reason it was judged unnecessary to introduce military drill. Scoutcraft is a means through which the vestal boonings can be brought to higher thought and to the elements of faith in God; and coupled with the scout's obligation "to do good turn every day," it gives the base of duty to God and to neighbour on which the parent or pastor can build with greater ease the form of belief that is desired. The *Scout Promise*, to carry out, *on his honour*, as far as in him lies, the *Scout Law*, is the binding disciplinary force. The aims and methods of the movement were inquired into by the Privy Council in 1912, and a Royal Charter of Incorporation was granted as an official recognition.

The outbreak of war in 1914 found thousands of scouts just rallying forth in their little, self-contained units with their trek carts and tents, and the Sea Scouts with their boats and equipment for their campings in the August holidays. By telegraph the object of their outing was changed, the Land Scouts were mobilized all over the country under the chief constables to protect the railway bridges, waterworks, telegraph and cable lines. At the same time Sea Scouts, at once took over the duties of watching the coast from the coast-guardsmen, who were called up for service afloat; and there they remained till the end of the war, working under the orders of the Admiralty. Some 23,000 boys took their turn at this service. Over 100,000 of the older scouts and scoutmasters took their places on service, and they did well. Ten thousand of them gave their lives for their country. Some of the V.C. heroes were Craig, Cates, Dimmer (also a Boys' Brigade man), Laidlaw, Toye, Cruikshank, McKean, Jack Cornwall, Dean, Haine and Hallows, formerly Boy Scouts.

Through scouting the boy has the chance to deck himself in a frontier kit as one of the great brotherhood of backwoodsmen. He can track and follow signs, he can signal, he can light his fire and build his shack and cook his grub. He can turn his hand to many things in pioneer and campcraft. His unit is a band of six, commanded by their own boy leader. Here may be seen the natural gang of the boy, whether for good or for mischief; responsibility and self-discipline for the individual; and *esprit de corps* for the honour of the patrol, as strong as any house-spirit in a public school.

To the outsider's eye the scout's staves are so many broomsticks, but to the scout they are different. His staff, decorated with his own particular totem and signs, is typical; like his staff, among a mass he is an individual having his own traits, his own character, his own potentialities. He may be one of a herd, but he has his own entity. He gets to know the joy of life through the out-of-doors. Then there is the spiritual side. Through sips of nature lore, imbibed in woodland "hikes," the pany soul grows up and looks round. The outdoors is *par excellence* the school for observation and for realizing the wonders of a wondrous universe.

At Olympia, London, in July and Aug. 1920, was held perhaps the most significant gathering of boys that has ever been known, when some hundred thousand Boy Scouts from 27 different countries—for the movement has spread over the world—came together to show to the public something of the aims, methods and results of "Scouting for Boys." The fact that these boys, wearing the same uniform and obeying the same Scout Law, had started a remarkable personal inter-comradeship, might well be an important factor toward developing that spirit of good-will on the part of the peoples themselves that was essential to the hopes founded on the League of Nations.

In 1921 there were 350,000 Boy Scouts in the British Empire, and approximately a million and a half throughout the world.

(R. B.-P.)

**United States.**—Early in 1910 the idea of introducing into the United States the Boy Scout movement, with methods similar to those of the English Boy Scouts, which had been instituted in 1908 and developed under the personal supervision of Lt.-Gen. Sir Robert Baden-Powell, was first proposed by Mr. W. D. Boyce of Chicago. Before this time a number of troops had been started in various parts of the country by men who had been impressed with the possibilities of the scheme through reading Sir Robert's English handbook, "Scouting for Boys." It is significant that Mr. Boyce's interest was aroused by a service rendered him in true scout spirit by a London Boy Scout who, because of his obligation to do a good turn daily and the rule against the acceptance of gratuities, greatly astonished and impressed Mr. Boyce. After a conference with Sir Robert he secured the cooperation of friends in Washington, D.C., and on February 8 1910 incorporated an organization of the Boy Scouts of America under the laws of the District of Columbia. With the cooperation of other agencies interested in boys, the plans for the organization were developed, and the administration was undertaken by a national council working through an executive board and through local councils and scout officials throughout the country. In 1910 a small office was opened in New York and in 1911 headquarters were established at 200 Fifth Ave. in that city. Federal incorporation was granted by Act of Congress in June 1916.

Boy Scouts are organized in patrols, 8 boys to a patrol, 2 to 4 patrols to a troop. Each troop is under the charge of a scoutmaster, who must be an adult American citizen, and one or more assistant scoutmasters. Troops are organized in connexion with schools, churches and other institutions, or under the auspices of a group of representative citizens. For each troop there is a supervising group of adults known as a troop committee. Where there are two or more troops in a community their activities are directed and supervised by local councils.

The national council is made up of representatives from these local councils and other distinguished men from every state in the union. This body meets annually in New York City, where the Council has its administrative and executive headquarters. The president of the Boy Scouts of America in 1921 was Mr. Colin H. Livingstone of Washington, D.C.; its honorary president, the President of the United States, and its chief scout executive, James E. West.

The purpose of the Boy Scouts of America as stated in its constitution is "to promote through organization, and cooperation with other agencies, the ability of boys to do things for themselves and others, to train them in scout-craft, and to teach them patriotism, courage, self-reliance, and kindred virtues, using the methods which are now in common use by Boy Scouts, by placing emphasis upon the Scout Oath and Law for character development, citizenship training and physical fitness." The movement is non-sectarian and non-partisan. The motto of the organization is: "Be prepared."

The membership in Sept. 1921 was 410,676 registered scouts, 119,283 scout officials, 17,738 troops, 607 local councils. (J. E. W.)

**Girl Scouts.**—In March 1912 Mrs. Juliette Low organized in Savannah, Ga., a group of Girl Guides, patterned after and bearing the same name as the organization developed in England by Lt.-Gen. Sir Robert Baden-Powell and Lady Baden-Powell. In both cases the purpose was to offer girls activities similar to those open to Boy Scouts. The movement spread rapidly and on June 10 1915 the organization was incorporated and its name changed to Girl Scouts. At first the national headquarters were in Washington, D.C., but later removed to New York City. In Oct. 1921 the number of registered Girl Scouts was about 120,000, and applications for membership were being received at the rate of 3,000 per month. The purpose is to instill patriotism, to arouse the spirit of helpfulness, and to develop character, largely through outdoor group activity. The motto is "Be prepared"; and the slogan, "Do a good turn daily." Each member promises: "On my honour, I will try to do my duty to God and my country, to help others at all times, to obey the Scout laws."

These laws, ten in number, require a Girl Scout to be trustworthy, loyal, helpful, friendly, courteous, kind to animals, obedient, cheerful, thrifty, and clean in thought, word, and deed. Originally the age limit was fixed from 10 to 18 years, and this central group continued to be the largest; but later a separate division was formed for little girls, known as Brownies or Junior Scouts, and another division for

mature girls, known as Citizen Scouts. The unit is a patrol of eight girls, who choose from their number a leader. One or more patrols form a troop, whose captain must be at least 21 years old and approved by the national headquarters. A captain may have one or more lieutenants, at least 18 years old and approved by the national headquarters. The official magazine is *The American Girl* (X.) a monthly publication.

**Camp Fire Girls.**—Another organization, wholly distinct, representing the scout movement in the United States is the Camp Fire Girls, for girls over twelve. It was founded in 1912 to promote the ideals of the "home, health and citizenship." The training stimulates love of being out of doors and an interest in simple handicrafts like block-printing and weaving. The organization accomplishes its work by recognizing the doing of small tasks well and by awarding "honour-beads" in the seven Camp Fire "crafts" of "home, nature, health, hand, camp, business, and patriotism or citizenship." The slogan is "Give Service," and the watchword "Wohelo" (work, health, love). There were 130,000 members in 1921, living in every state of the United States and in 18 foreign countries. An allied junior organization is the Blue Birds. The official organ is *Everygirl's Magazine*. The headquarters of the Camp Fire Girls are in New York City.

**BRACQUEMOND, FÉLIX** (1833-1914), French painter (see 4-369), died in Paris Oct. 29 1914.

**BRADBURY, SIR JOHN SWANWICK** (1872- ), English civil servant, was born at Winsford, Cheshire, Sept. 23 1872 and educated at the Manchester grammar school and Brasenose College, Oxford. He entered the civil service in 1896. Beginning in the Colonial Office, he was soon transferred to the Treasury. In 1911 he was appointed a member of the National Health Insurance Commission, but in 1913 returned to the Treasury as joint permanent secretary. In that capacity it fell to his lot to sign the currency notes issued by the Government when gold was withdrawn from circulation on the outbreak of the World War. Hence their first popular name of "Bradburys." He was made K.C.B. in 1913, and in 1919 was appointed chief British representative on the Reparations Commission. In 1920 he was given the G.C.B.

**BRADDON, MARY ELIZABETH** [MRS. JOHN MAXWELL] (1837-1915), English novelist (see 4-369), died at Richmond, Surrey, Feb. 4 1915. Among her latest novels were *The Green Curtain* (1911) and *Miranda* (1913).

Her son WILLIAM BABINGTON MAXWELL (1866- ), born June 4 1866, became known as a novelist and newspaper correspondent. His novels include *Vivien* (1905); *The Guarded Flame* (1906); *Mrs. Thompson* (1911); *The Mirror and the Lamp* (1918); *A Man and his Lesson* (1919) and *A Remedy against Sin* (1920). He served with the Royal Fusiliers during the World War (1915-7) and attained the rank of captain.

**BRAGG, SIR WILLIAM HENRY** (1862- ), British physicist, was born at Wigton, Cumb., on July 2 1862 and was educated at King William's College, Isle of Man. He subsequently entered Trinity College, Cambridge, being elected to a major scholarship in 1882. He was third wrangler in 1884 and in the following year obtained a first class in part III. of the mathematical tripos. In 1886 he was appointed professor of mathematics and physics in the university of Adelaide, S. Australia, where he carried out his earlier researches upon radioactivity. He took an active interest in the development of scientific enterprise in Australia, was a member of the council of the Adelaide University from 1893 to 1908, of the council of the South Australian School of Mines and Industries from 1895 to 1908 and president of the Australasian Association for the Advancement of Science, Brisbane, 1909. In 1909 he was appointed Cavendish professor at Leeds University, where he remained until his election in 1915 to the Quain professorship of physics in the university of London. His researches upon various radioactive phenomena and his power of lucid exposition brought recognition from scientific bodies both at home and abroad; in 1906 he was elected a fellow of the Royal Society; in 1915 he received the Nobel Prize for Physics and the Barnard gold medal (Columbia University), both of which distinctions he shared with his son William John Bragg (b. 1890), who in 1919 became

Langworthy professor of physics in the university of Manchester. The joint work of father and son has gone far towards elucidating the arrangements of atoms in crystals, an achievement rendered possible by their development of the X-ray spectrometer. During the World War Sir William Bragg's services were placed at the disposal of the Admiralty, where he served in an advisory capacity; he was more especially associated with the problem of submarine detection. His public services of a confidential nature were acknowledged by the bestowal of the C.B.E. in 1917 and by his creation as K.B.E. in 1920. In the same year he was elected an hon. fellow of Trinity College, Cambridge, and served as president of the Physical Society of London.

In addition to many publications, chiefly upon radioactivity, in the *Philosophical Magazine* and the *Proceedings of the Royal Society*, he has written *The World of Sound* (1920), a compilation of a series of lectures given to a juvenile auditory at the Royal Institution in 1919 and, in collaboration with W. L. Bragg, *X-Rays and Crystal Structure* (1915).

**BRAMLEY, FRANK** (1857-1915), English painter, was born near Boston, Lincs., May 6 1857. He studied art at Lincoln and later at Antwerp, first exhibiting in the Academy in 1884. Bramley became one of the best-known members of the group of English painters known as the Newlyn school, and in 1888 his picture, "A Hopeless Dawn," was bought under the terms of the Chantrey bequest. He became A.R.A. in 1894, and was elected R.A. in 1911, being also a gold medalist of the French Salon. He died at Chalford Hill Aug. 10 1915.

**BRANDEIS, LOUIS DEMBITZ** (1856- ), American lawyer and jurist, was born in Louisville, Ky., Nov. 13 1856. He was educated in the public schools of his native city and at the Annen Realschule, Dresden, Germany. He graduated from the Harvard Law School in 1877, was admitted to the bar in 1878, and practised in Boston from 1879 to 1916. As a member of the Public Franchise League he took an active part in preserving municipal control of the Boston subway. He was instrumental in securing the passage of the Boston Sliding Scale Gas Act and was a pioneer in the movement for establishing life insurance through savings banks. He opposed the monopoly of transportation by the New Haven railway in New England. He was much interested in labour legislation, acting as counsel for the people in cases involving the constitutionality of fixing hours of labour and a minimum wage in several states. In 1915 he acted successfully as counsel for the Government in the suit brought by the Riggs National Bank in which the bank charged the Secretary of the Treasury and the Comptroller of the Currency with conspiring to wreck it. In Jan. 1916 he was appointed by President Wilson to succeed the late Justice Lamar as associate justice of the United States Supreme Court, being the first Jew to attain this position. He was the author of *Other People's Money* and *Business as a Profession*, besides numerous articles on public franchise, business efficiency, labour and trusts. He was prominent in Zionism and in 1914 was made chairman of the provisional committee for Zionist affairs.

**BRANDES, GEORG MORRIS COHEN** (1842- ), Danish critic (see 4.427). The complete popular edition of his works was published in Copenhagen in 18 vols. between 1890 and 1910, and the German edition appeared in Munich in 8 vols. between 1902 and 1904. His later monographs include *Armand Carrel* (1911); *Goethe* (1919); *Voltaire* (1936); *Napoleon and Garibaldi* (1917) and *Caius Julius Caesar* (1918). He produced in 1919 a study of the Schleswig-Holstein question, *Sønderjylland under prejsisk Tryk* (South Jutland under Prussian Tyranny), and a drama, *Tragediens anden Dd. Fredsuddingene*.

**BRANGWYN, FRANK** (1867- ), English painter (see 4.430). Among his later works are decorations for the Courts of Justice, Cleveland, U.S.A., and the new Parliament building at Winnipeg, Canada. He also decorated the Court of the Seasons at the Panama-Pacific Exposition, San Francisco, and in 1921 was engaged on work for the State Capitol of Missouri

**BRANTING, HJALMAR** (1860- ), Swedish statesman, was born in 1860. As a student he seemed at first destined for a scientific career. He early devoted himself to astronomy and for a period he acted as junior official in the observatory of Stockholm. His keen interest in political and social questions, however, soon drew him into journalism and into active politics, and he threw in his lot with the then small group of Social Democrats in Sweden. In 1886 he assumed control of the weekly journal *Socialdemokraten*, their leading organ, which later was converted into a daily. In 1888 he was condemned to a short term of imprisonment on account of his articles. He was elected a member of the Second Chamber of the Riksdag in 1896. An able speaker and tactician, he exercised in Sweden an influence proportionate to the growing numbers of his supporters. He joined the Eden Government in the autumn of 1917 as finance minister, and when this ministry fell in 1920 Branting became prime minister and formed an entirely Social-Democratic administration which, however, resigned office in the autumn of the same year (see SWEDEN). Meanwhile he had played an important rôle in international labour politics. He acted as representative of Swedish Social Democracy at all the congresses of the First International, and in the summer of 1917 he was chairman of the Dutch-Scandinavian delegation which sat in Stockholm and conferred in turn with delegations from the Socialist parties of most of the belligerent countries with a view to devising a platform for joint intervention by them in the interests of peace, the moving power being Camille Huysmans, the secretary to the International. Their efforts were unavailing. In Jan. and Feb. 1919 Branting was chairman of the International Social-Democratic Conference in Berne, at which British, French and Germans met for the first time since the war. He was a member of the executive committee of the Second International, which later sat in London with Mr. Henderson as its chairman. He had taken an active part in most of the Scandinavian workmen's congresses since 1886; and at the ninth congress in Copenhagen in 1910 he introduced the question of "democracy and dictatorship," the debate on which ended with the passing of a resolution by a solid majority, representing up to 800,000 organized workmen, against a small Norwegian minority, disapproving of the Bolshevik policy and adhering to the Second International.

Branting took a warm interest in the claim of the inhabitants of the Åland Is. to be allowed to decide the permanent position of the islands by means of a plebiscite, and he represented Sweden in this matter at the first attempt in Paris in 1919 to secure a decision from the Supreme Council, at the consideration of the problem by the Council of the League of Nations in London in July 1920, in Paris in Sept. 1920, and at Geneva in July 1921 (as Sweden's leading delegate). He was Sweden's leading delegate also at the first meeting of the League of Nations at Geneva in Dec. 1920 and chairman of the sixth commission which dealt with the questions of disarmament, of blockade and of mandates. He was elected by the Council a member of the "Commission temporaire pour la réduction des armements," for the carrying-out of which the commission made an appeal.

**BRASSEY, THOMAS BRASSEY, 1ST EARL** (1836-1918), British politician (see 4.435), who was created an earl in 1911, died in London Feb. 23 1918. He was succeeded by his son, THOMAS ALLNUTT BRASSEY (b. 1863), who died in London Nov. 11 1919. The 2nd earl left no children, and the title became extinct.

**BRAUN, HEINRICH** (1854- ), German Social Democrat and writer on social questions, was born Nov. 23 1854 at Leipzig, and studied at Vienna, Göttingen, Berlin and Halle. He successively edited the important Socialist publications, *Die neue Zeit*; the *Archiv für soziale Gesetzgebung und Verwaltung*; *Die neue Gesellschaft*; and *Annalen für Socialpolitik und Gesetzgebung*. After the revolution and the election of a Prussian Constituent Assembly, Braun was Minister for Agriculture in the Prussian Socialist Ministry formed under the presidency of Hirsch on March 24 1919.

LILY BRAUN (1865-1916), wife of the above, was one of the most remarkable women Socialists and writers of modern Ger-

many. She was the daughter of Gen. von Kretschmann, of an old East Prussian Junker stock, and was born at Halberstadt on July 2 1865. Her grandmother was the issue of one of the *smours* of Prince Jerome Bonaparte, King of Westphalia. Her whole early life was passed in a Junker and militarist atmosphere, on the East Prussian estate of her grandfather, or in the various garrisons where her father held command. She had a deeply introspective nature and read widely. The romantic as well as the social and ethical ideas which she developed contributed to alienate her from her class and her family and to draw her into the Socialist movement. Her first marriage (against the wishes of her family) was with an invalid socialistic professor, von Gizycki. After his early death she was attracted by the Socialist author and politician Heinrich Braun and married him in 1895. She visited England and was on terms of friendship with leading members of the Fabian Society. She was the author of many books and pamphlets on social questions, particularly on the place of woman in politics and industry, e.g. *Frauenfrage und Socialdemokratie* (1901); *Frauenarbeit und Handwirtschaft* (1901); *Die Politik und die Frauen* (1904). But her most remarkable work was the story of her own life, told, like Goethe's autobiography, with some embellishments of fancy and, indeed, professedly in the form of a novel. The two volumes are entitled *Memoiren einer Sozialistin* (1) *Lehrjahre* (2) *Kampffahre* (1909 and 1911). They give an elaborate picture, coloured no doubt by the intense self-consciousness of the writer, of the growth of the German Social Democratic movement in the 'nineties, with sketches of the leading figures, such as Bebel, Liebknecht, Rosa Luxemburg, and her own husband, Heinrich Braun. No German book brings out more clearly the nature of the cleft between the German and Prussian governing and military classes on the one side and the industrial masses and their leaders on the other. The contrast between German life in the country and in the cities is also vividly portrayed, as is the social life of a regiment and a garrison. Other books of hers are *Im Schalten der Titanen* (memoirs of her grandmother, who lived for a time in Goethe's circle); *Liebesbriefe einer Marquise*; a play, *Mutter Maria*, and a novel, *Lebenswucher*. She died on Aug. 8 1916.

**BRAZIL** (see 4.438).—No general census of Brazil had been taken between 1900 and 1920, but the total pop., estimated in 1908 at 20,515,000, was officially stated in 1917 to be 27,473,570. This figure, which is probably somewhat exaggerated, would give an average density of 8.3 per sq. mile. Estimates of municipal pop. in 1913 (probably not very accurate) were: Rio de Janeiro, 976,000; São Paulo, 400,000; Bahia (São Salvador), 348,000; Pará (Belem), 275,000; Pernambuco (Recife), 216,500; Porto Alegre, 150,000. The problem of immigration for so scantily peopled a country is a vital one. Its great fertile plains yield all the products of the tropics and sub-tropics, and it has immense wealth in natural resources, yet its forests are almost untouched, its enormous mineral deposits scarcely tapped, while grazing and agriculture are still far behind their possible development.

Vast regions in the interior are still unsettled, and some even unexplored. The most notable geographical achievement of the decade 1910–20 was the expedition made in 1914 by Theodore Roosevelt, in conjunction with Col. Rondon and other Brazilian officers, down the Rio Duvida (River of Doubt), of which by far the greater part had never been visited. The personnel of the expedition included, besides Theodore Roosevelt, his son, Kermit Roosevelt, two biologists, an engineer and a surgeon. The journey, interrupted by many portages, involved a distance of 470 m., and lasted two months, from Feb. 27 to April 26. After four days' progress down stream, cataracts were met with, and the next 60 m. took 42 days to accomplish. The river proved to be a tributary of the Madeira, some 940 m. in length, and joined the main stream in lat. 5° 20' S. The general course, though very tortuous, is due N. running through rugged, densely wooded country almost devoid of animal life. It is now officially known as the Rio Roosevelt. In *Through the Brazilian Wilderness*, Roosevelt gave the credit for the discovery to Col. C. M. da Silva Rondon and to those associated with him on the Telegraph Commission during their six years' work before his own journey.

The number of immigrants registered during the years 1908–19 was as follows:—

1908	94,695	1914	82,572
1909	85,410	1915	32,206
1910	88,564	1916	34,033
1911	135,967	1917	31,192
1912	180,182	1918	20,501
1913	192,683	1919	37,498

Of the total 926,312, for the period 1908–16 inclusive, 354,820 were Portuguese, 190,767 Spaniards, 153,980 Italians, and 85,578 Germans. There were also 49,477 from Russia (chiefly Poles), 41,534 Turko-Arabs, and 21,843 from the Slavic parts of Austria. No racial statistics for 1917–9 are available. In 1911 arrangements were concluded with Japan to allow the immigration of Japanese agricultural labourers into São Paulo, and over 13,000 entered in the next two years. The agreement was renewed in 1916 so as to permit the coming of 5,000 annually. Immigration was greatly retarded by the World War, and when Italy entered the conflict in 1915 not only did Italian immigration cease, but many Italian subjects in Brazil were called home for military service, with the result that the labour market was seriously depleted. It was estimated that 50,000 sailed from São Paulo alone. When the Armistice was concluded in the autumn of 1918, the Brazilian Government notified all consular agents in the country that to agricultural immigrants accompanied by families aid would be gratuitously supplied, including food, tools, medical treatments, freedom from duties on baggage, transport by rail or water, etc. Those settling in the Federal colonies would also be given employment to the extent of 15 days' work a month for each adult, and temporary quarters would be provided for such as desired to build dwellings. In 1921 difficult post-war conditions in Europe were rapidly turning the tide of immigration again in the direction of Brazil.

*Agriculture* continues the chief source of Brazil's wealth. The leading crop is *coffee*, of which it produces about four-fifths of the world's supply. Over half is grown in the state of São Paulo alone, the rest coming from the states of Rio de Janeiro, Minas Geraes and Espírito Santo. The average production is somewhat over 12,000,000 bags a year (bag = 60 lb. = 27.22 lb.), the harvest fluctuating greatly with varying climatic conditions. The following official figures are published for the years 1915–9:—

	Bags Exported	Value in Pounds Sterling	Per cent of Agric. Prod. Exported	Per cent of all Prod. Exported
1915	17,061,398	32,190,547	68	59
1916	13,039,145	29,280,694	63	52
1917	10,606,014	23,054,280	49	36
1918	7,433,048	19,040,764	42	31
1919	12,953,250	27,607,208	66	55

A constant effort is made to maintain the price, by imposing an additional tax on exports over a certain amount, by encouraging consumption through propaganda abroad, and in São Paulo by prohibiting further extension of coffee plantations. The Coffee Convention or Valorization Scheme of 1907 (see 6.647) was resorted to again in 1917. In 1907, when the planters of Brazil faced ruin owing to over-production, the state of São Paulo, supported by the Federal Government, and with funds borrowed largely from foreign bankers, bought up 8,000,000 bags and stored them for disposal in a more favourable market. When the World War broke out, coffee to the amount of 3,000,000 bags still lay in European warehouses, most of which was eventually taken over by the belligerent Governments. In 1917 the state of São Paulo, to stabilize the price which was threatened by a large crop and restricted markets, purchased about 3,000,000 bags, and constructed enormous warehouses for their storage on the docks at Santos. The destruction by frost of a large part of the 1918 crop saved the Government from an anxious situation.

The areas of cultivation of mandioca, corn, cotton, tobacco, sugar and cacao have all increased in recent years. Rice, once imported, is so extensively grown that imports of it have virtually ceased. Of cacao Brazil supplies the major part of the world's demand, most of the crop coming from the state of Bahia. The output increased from about 33,000 metric tons in 1910 to over 65,000 in 1919. Sugar, the country's principal export in colonial times, is produced largely in the states of Rio de Janeiro and Pernambuco. The entire crop in 1917 was reckoned at about 420,000 metric tons, of which 138,169 tons were exported. This last figure was unusual and due to the encouragement of war prices abroad. Brazil consumes most of its own supply, the normal export rarely exceeding 60,000 tons. With the continued introduction of modern milling machinery, the production of sugar should become one of the principal sources of national wealth. Tobacco is grown in various states, but especially in Bahia and Rio Grande do Sul. The Bahia product challenges in quality that of the Vuelto Abajo district of Cuba, and finds a ready market in Europe, while that of Goyaz and Minas Geraes is highly esteemed for cigarettes. The annual production of Brazil was placed in 1917 at 45,000 metric tons of which about 26,000 were exported.

**Cotton** is native to Brazil, and may be grown in all parts of the republic. The best cotton lands are in the centre and along the N.E. coast to the mouth of the Amazon, where the finest varieties produce a long silky fibre equal to the Sea Island or the Egyptian. Annual production is reckoned at from 90,000 to 100,000 metric tons, but the export of raw cotton, mostly to England, fluctuates widely from year to year. The best year of the period 1910-20 was 1913, when 37,500 tons were shipped abroad, worth over £2,300,000. The average in recent years has been about 5,000 tons. By a presidential decree of March 27 1920 a cotton service was established to investigate the properties of the soil and climatic conditions, create experimental stations, and provide the planters at cost with machinery, implements and fertilizers. With these measures of encouragement taken by the Federal Government, the increasing enterprise of individual firms and planters to improve conditions of production, and with more careful selection and standardization of the fibres, Brazil should some day become the world's greatest exporter of high-grade cotton. The only important wheat-producing state in 1921 was the southernmost, Rio Grande do Sul, which supplies about half of its own needs; but Santa Catharina, Paraná, and the high interior of the south-central states are also suitable for the cultivation of this cereal. **Stock-raising** advanced notably during 1910-20, especially in Rio Grande do Sul, but also in the states of Minas Geraes, Paraná, São Paulo, Rio de Janeiro and Matto Grosso. The industry is being put on a modern basis, packing plants of the latest design and of high efficiency are in operation or projected, and dairy products have become valuable. The first two packing houses in Brazil were established in the state of São Paulo, one with North American capital, the other with Brazilian. A packing plant has been completed at Rio Grande by the Companhia Swift do Brazil, and another in the city of São Paulo by the Companhia Armour do Brazil. Canning establishments have been erected at Rosario and Sant' Ana do Livramento, in the state of Rio Grande do Sul, and Rio de Janeiro now possesses cold-storage plants with large capacity. Official statistics of live stock in 1913 were as follows:—

Cattle . . . . .	30,705,400	Goats . . . . .	10,048,570
Horses . . . . .	7,280,690	Sheep . . . . .	10,549,930
Mules . . . . .	3,207,940	Swine . . . . .	18,400,530

The increasing importance of the cattle industry since 1914 may be gathered from the following figures:

*Exports of Chilled and Frozen Beef.*

	Metric tons	Value
1914 . . . . .	1	62
1915 . . . . .	8,514	309,706
1916 . . . . .	33,661	1,414,460
1917 . . . . .	66,452	3,184,461
1918 . . . . .	60,509	3,246,352
1919 . . . . .	51,634	3,381,486

*Exports of Preserved Meats.*

	Metric tons	Value
1915 . . . . .	123	8,202
1916 . . . . .	856	78,571
1917 . . . . .	6,552	514,695
1918 . . . . .	17,223	1,402,892
1919 . . . . .	25,398	2,447,093

**Rubber** is still the most important of the forest products of the republic, and ranks next to coffee in export value, although it is being rapidly overtaken by exports of meats and hides. Since 1910 the rubber industry has suffered severely from the competition of cheaper plantation rubber from the Orient, especially since the slump in the market following the artificial demand stimulated by the World War. The Federal Government in 1913 undertook, in cooperation with the state of Pará, an ambitious plan for the relief of the industry, involving reductions in export duties, developments of transportation facilities, and the establishment of an experiment station. But, although a few plantations have been created, there is as yet little improvement in the industry at large. The "rubber" state of Pará will probably be forced to direct its attention in part to the production of other crops, such as cereals, sugar, mandioca and various vegetable fibres.

The exports of Pará rubber and their value during the years 1915-9 were as follows:—

	Metric tons	Value
1915 . . . . .	35,165	£7,039,697
1916 . . . . .	31,495	7,496,386
1917 . . . . .	33,998	7,484,170
1918 . . . . .	22,662	3,998,770
1919 . . . . .	33,252	6,239,794

In Paraná the lumber industry, while still in its infancy, was making rapid progress in 1920. Two large saw-mills, recently erected and equipped with the most modern North American machinery, were cutting Paraná pine and shipping the product to other parts of the country and to Argentina. Cedar for the manufacture of cigar boxes was also being shipped from this state to Rio de Janeiro and Bahia. Brazil has very great wealth in fibre and wood-pulp for paper-making, especially in the huge pine forests of Paraná, and Santa

Catharina. In 1921 only common grades such as wrapping paper were manufactured, but enough newspaper could be produced to supply the entire republic and even neighbouring nations, as Argentina and Uruguay. Another valuable forest production of Paraná is maté or Paraguay tea, most of which is purchased by Argentina, Uruguay and Chile. Over 76,000 tons were exported in 1916, and 90,000 tons in 1919, representing a value of £1,885,000 and £3,200,000 respectively.

**Minerals.**—Lack of transportation and high export duties still serve to check the exploitation of Brazil's immense mineral resources. Gold and diamonds are now produced only in small quantities. Minas Geraes possesses considerable deposits of iron ore, which are being carefully examined by foreign experts, and plans are on foot for the erection of modern furnaces. The output of manganese ore, mostly in the states of Minas Geraes and Bahia, increased rapidly during the World War, rising to 532,855 tons in 1917, the major part going to the United States. The production of mica was also greatly stimulated, exports increasing from 51 tons in 1915 to 162 tons in 1918. The world's supply of monazite sand comes largely from Brazil, although its exportation declined during the World War. There are coal deposits in Rio Grande do Sul, Paraná, Santa Catharina and elsewhere, but most of it is of poor quality. In March 1918 the Federal Government offered assistance in the way of loans to coal-mining enterprises whose output exceeded 150 tons a day. Most of the coal used for industrial purposes is still imported from England and the United States.

**Manufactures.**—Factory products showed a marked development during 1910-20, especially after 1914 when the World War decreased the supply of goods from abroad. The city of São Paulo, rapidly becoming the chief industrial centre, claimed in 1920 over 350 factories, large and small, with an investment of about £25,000,000. But manufacturing is also very active in the states of Minas Geraes and Rio de Janeiro, especially where water-power is accessible. Some of Brazil's industries, such as cotton textiles, tobacco and sugar, are natural to the country as they consume raw materials produced at home; others are at present purely artificial, encouraged by the protective barrier of heavy import duties from which the Federal Government secures the larger part of its revenues. In some industries practically every item entering into the manufacture of their product comes from abroad. The textile industry has made greater progress perhaps than any other, chiefly in cotton goods, and in 1921 it accounted for about 40% of the total production of manufactured articles. In 1905 there were 110 cotton mills in Brazil, with 26,420 looms and 734,928 spindles, representing a capital of £10,384,000, and producing nearly 264,000,000 yd. of cloth. In 1915 there were 240 mills, with 51,420 looms and 1,512,626 spindles, £21,596,000 capital, and an annual production of over 500,000,000 yards. The whole of this native textile production is sold in Brazil, supplying over 80% of the fabrics used.

There are several large shoe factories in Rio de Janeiro and São Paulo. Brazil manufactures 97% of its footwear. Great progress has been made in the tanning industry but owing to the inferior quality of native hides the output is confined mostly to sole and belting leather. The grazing regions of Rio Grande do Sul, however, produce fairly high-grade hides, and with importations from Uruguay and Argentina the tanners have begun to turn out a good quality of leather which competes with imported stock. The principal tanneries are in or near Rio de Janeiro and São Paulo, but there are a number of small establishments in Rio Grande and Porto Alegre and in a few of the northern cities. In 1919 sole leather was exported to the value of £246,692. It seemed probable that within a few years Brazil would become a producer of rubber goods as well as of the crude "Pará." There were already in 1921 a few small rubber factories in Rio de Janeiro and São Paulo, doing an increasing business, and a North American rubber corporation was about to erect a large factory near Rio for the manufacture of tires.

**Commerce.**—The value of Brazilian imports and exports during the years 1910-9 is shown in the following table:—

	Imports	Exports	Total
1910	£47,872,000	£63,092,000	£110,964,000
1911	52,822,000	66,839,000	119,661,000
1912	63,425,000	74,649,000	138,074,000
1913	67,166,000	65,451,000	132,617,000
1914	35,473,000	46,803,000	82,276,000
1915	30,088,000	53,951,000	84,039,000
1916	40,369,000	56,462,000	96,831,000
1917	44,510,000	63,631,000	107,541,000
1918	52,817,000	61,168,000	113,985,000
1919	78,177,000	130,685,000	208,262,000

Arranged by countries of origin or destination, the figures for 1916-9 are given in the tables on the next page. The effect of the rise in prices is shown, of course, in the period after the war started; and this superficially neutralizes to some extent in money-value the effect of the restrictions on over-sea trade. The jump in the figures from 1918 to 1919 represents the freeing of commerce combined with the rise in prices, particularly in the case of France, America and Great Britain.



## BRAZIL

## IMPORTS FROM

	1915	1916	1917	1918	1919
United States	\$9,651,305	\$15,840,605	\$21,065,302	\$18,984,413	\$37,422,732
Great Britain	6,596,897	8,228,784	7,979,264	10,783,721	12,737,231
Argentina	4,786,028	5,675,425	5,791,925	10,020,245	12,032,250
France	1,486,525	2,095,378	1,785,118	2,518,993	2,967,405
Portugal	1,490,323	1,872,049	1,435,574	2,027,917	2,364,524
Italy	1,327,013	1,410,597	878,005	1,126,521	1,067,111
Newfoundland	647,229	691,195	746,686	1,283,556	1,232,676
India	560,746	651,783	984,414	661,977	1,691,720
Norway	300,095	411,104	360,547	229,830	380,767
Germany	458,285	17,729	48,049	—	201,033
Uruguay	447,344	600,566	607,678	2,208,341	1,741,643
Spain	431,883	469,222	601,252	937,184	872,483
Switzerland	318,453	512,430	349,722	407,850	415,621
Sweden	265,436	268,692	398,059	498,152	879,024
Canada	243,353	241,562	236,668	222,922	253,487
Netherlands	206,807	237,270	46,397	63,093	314,190
Mexico	142,800	257,270	187,241	334,342	555,333
Denmark	131,652	238,666	79,684	41,464	28,387
Paraguay	66,690	41,684	64,604	9,727	23,838
Belgium	51,777	57,959	22,191	—	110,132
Austria-Hungary	39,678	304	86	—	4,646
Japan	10,759	23,321	72,321	326,226	500,624

## EXPORTS TO

	1915	1916	1917	1918	1919
United States	\$22,149,556	\$25,831,905	\$28,013,136	\$21,287,015	\$54,079,947
Great Britain	6,475,698	6,493,249	7,811,815	6,168,829	9,483,666
France	6,031,852	8,899,577	8,325,754	5,564,065	27,267,743
Sweden	4,775,722	1,531,800	77,674	290,179	3,337,429
Netherlands	3,369,821	1,684,819	320,347	—	4,090,386
Argentina	2,692,429	3,393,699	5,707,387	9,296,626	5,836,881
Uruguay	1,796,540	2,698,549	4,685,202	6,362,338	5,708,210
Italy	1,662,748	3,401,060	4,853,614	6,421,278	3,821,439
Norway	1,568,316	294,578	296,757	512,723	1,016,129
Denmark	1,221,285	414,134	156,863	99,546	2,386,736
Portugal	486,117	313,600	273,807	554,625	693,138
Cape Colony	379,973	440,774	612,379	478,834	577,095
Spain	308,675	446,879	852,745	1,332,927	2,028,899
Egypt	263,858	91,094	291,284	174,769	365,175
Greece	203,844	4,700	—	37,363	438,567
Chile	147,390	151,429	150,976	186,684	397,127
Cuba	43,865	140,672	269,168	200,233	185,033
Belgium	—	—	—	323,434	4,740,737
Austria-Hungary	—	—	—	135,418	444,963
Germany	23	—	—	—	701,497

Approximate figures for the year 1913 provide means of comparison with conditions before the outbreak of the World War.

	Imports from:	Exports to:
Great Britain	\$16,450,000	\$8,587,500
Germany	11,747,000	9,141,000
United States	10,562,000	21,121,000
France	6,577,500	7,966,500
Argentina	5,003,000	3,057,500
Belgium	3,435,000	1,657,500
Portugal	2,959,500	327,500
Italy	2,846,500	637,500
Uruguay	1,881,000	1,064,000
Austria-Hungary	1,015,000	3,131,500
Newfoundland	788,500	—
Netherlands	728,500	4,788,500
Norway	709,500	100,000
Spain	642,000	367,000
India	552,500	—
Sweden	294,500	658,000

Among the leading imports of Brazil are iron and steel manufactures, machinery, railway supplies, coal, kerosene, cement, cotton goods, foodstuffs, and raw materials and articles for use in the arts and industries.

The principal ports of entry are Rio de Janeiro and Santos, but Pará, Pernambuco, Bahia, Porto Alegre and Rio Grande have a large and increasing foreign trade.

**Shipping.**—The Brazilian merchant marine increased but slowly in 1910-20, except for the German steamers seized during the war. Brazilian shipping in 1911 consisted of 238 steamers of 130,582 tons net, and 290 sailing vessels with a net tonnage of 60,728. At the end of 1917 there were 405 steamers of 336,533 tons net, and 54 sailing ships representing 17,920 tons net. Brazil in that year took over all the German ships interned in her ports at the outbreak of war in 1914, a total of 45 vessels with a net tonnage of 148,255. Thirty were leased to France, the rest turned over to the Lloyd Brasileiro, which considerably expanded its foreign service, especially to the United States.

**Communications.**—The railways of Brazil, aggregating 13,271 m. of track in 1910, had increased in 1917 to 17,159 m.; with 2,223 m. under construction and 4,697 m. projected. The states having the greatest railway mileage were São Paulo, Minas Geraes, Rio de Janeiro, Rio Grande do Sul and Bahia which together contain over 70% of the mileage of the republic. One of the most extensive systems is the Central of Brazil, a Government-owned and operated property, connecting the federalized district with the states of Rio de Janeiro, São Paulo and Minas Geraes. The total length of the line in 1917 was 1,466 miles. In that year it carried 32,639,600 passengers, 2,388,000 tons of freight, and 530,000 head of live stock.

Owing to the wide separation of the principal centers of population along the coast, Brazilian railways have developed as a series of independent systems. Thus Pernambuco became the focus of one system, Bahia, Rio de Janeiro, Santos, and Rio Grande do Sul of others. For some time the need was recognized of connecting the various systems by interior lines running N. and S., to afford communication independently of the sea, and to stimulate internal settlement and trade. Such plans have been carried out in N. and S. of Pernambuco (from Natal to Macaé), and from Rio de Janeiro to Victoria and S. to the Uruguayan frontier, where connexion was made in 1913 with Uruguayan Central. It is therefore possible to travel by rail from Rio direct to Montevideo, a distance of 1,967 miles.

Construction, however, was not limited to the coastal region. In 1916 a line of considerable importance was completed between Itapura on the Paraná river and Porto Esperança near Corumbá on the Bolivian frontier, the principal city of the state of Mato Grosso. The resulting direct rail connexion with the state of São Paulo reduced the time between Rio and Corumbá to six days, in place of a trip by water of from six to eight weeks. Extensions of the Rio system northwestward into the state of Goyaz and of the system of Ceará were planned or under construction in 1921. The Maracá-Mamoré line, passing round the dangerous falls of the Madeira river, was practically completed in 1912. Driven through deep forest in a deadly climate, it is one of the most costly railways in the world. It is 182 m. in length and of great importance for the Acre territory and Bolivia.

In 1909 there were 36,199 m. of telegraph reported in Brazil which had increased to 41,799 m. In 1917, of which 24,640 m. belonged to the Government. In the latter year 680 telegraph offices were reported, and 33 radio stations. The station at Pará (Belem) has a range of 4,000 m., and is thus capable of direct communication with the United States. The station at Cape Santa Marta, with the same range, connects with Cape Town in South Africa. In 1911 a new trans-Atlantic cable was completed between Monrovia (Liberia) and Pernambuco, and in 1919 an American-controlled connection established with the United States, via Argentina and the W. coast. Brazil has now three cable lines connecting with Europe, two with North America, and two with the River Plate. The number of post-offices in the republic in 1918 was 3,611. Brazil from Jan. 1 1914 adopted standard time and the longitude of Greenwich.

*Finance*.—The following official figures are reported for 1919.—

National debt, Foreign . . . . .	116,281,966 pounds sterling.
National debt, Internal . . . . .	1,042,000,000 milreis paper.
Currency in circulation . . . . .	1,709,113,473 milreis paper.
Conversion fund . . . . .	20,922,410 milreis gold.
Guarantee fund . . . . .	48,391,020 milreis gold.
Unredeemed bills and notes, gold and paper . . . . .	14,632,500 milreis.
General taxes for 1920 . . . . .	519,452,949 milreis gold; 154,238,200 milreis paper.
Estimated expenditure . . . . .	72,372,326 milreis gold; 599,578,557 milreis paper.

*Army and Navy*.—The army is organized on the basis of compulsory military service between the ages of 21 and 44, under the terms of a law promulgated in Jan. 1908. The service required is two years with the colours, seven in the reserve, seven in the second line, and eight in the national guard. By a decree of Dec. 1917 the national guard is incorporated with the second line. The total strength of the active army in the autumn of 1918 was 54,000, but mobilization would yield about 120,000. There is also a gendarmerie of 26,000. The Brazilian navy in 1920 comprised two Dreadnoughts, two coast defence ships, three protected cruisers, two river monitors, four river gunboats, four small cruisers, four torpedo boats, ten destroyers, a mine ship, three submarines and a submarine salvage vessel. Five destroyers and three large submarines are under construction. The personnel comprised about 13,000 men.

*Education*.—The latest figures available in April 1921 gave the number of primary schools in the republic at about 13,000, with an enrolment of over 700,000. Of these schools about half are supported by the state Governments, one-fourth are municipal, and the rest private institutions. Secondary and normal instruction is cared for by various institutes and private establishments, of which there are between three and four hundred attended by some 40,000 pupils. The republic also possesses 28 industrial schools, 11 agricultural and 9 commercial schools. To further industrial education the Federal Government may aid the state Governments, or municipal and private schools which meet its requirements. Twenty-five faculties confer technical and professional degrees and those in the Federal capital have been recently organized as a university. A school of fine arts, a national institute of music, a military college, a naval academy and a preparatory school of tactics are maintained by the Government at Rio de Janeiro, and there are schools of art and music in a number of the states.

*Political History*.—Marshal Hermes da Fonseca, leader of the Conservative party and former Minister of War, was elected President of the republic in March 1910, over Sr. Ruy Barbosa. The latter part of the year was marked by serious disturbances in Rio de Janeiro and in the north. At Manáos, capital of the state of Amazonas, the governor was forcibly removed by the Opposition, aided by Federal troops and by the flotilla on the river, but was reinstated by order of the President of the republic. At Rio de Janeiro on the night of Nov. 22 the crews of two new Dreadnoughts, the "Minas Geraes" and the "São Paulo," mutinied in the harbour, killed several officers, and, training their guns on the city, sent a demand to the President for the abolition of corporal punishment, increased pay and shorter hours of labour. Four other ships joined the movement so that it included most of the Brazilian navy. As no response was received the city was bombarded next day, whereupon Congress granted the demands and passed an act of general amnesty. The mutineers meanwhile had put out to sea, but returned Nov. 27 and gave up the ships to the Government. On the night of Dec. 9, the marine corps stationed on Cobras Island in the harbour also mutinied. Their position was bombarded next day, the mutineers replying with shrapnel. After an action lasting ten hours, the rebels surrendered, having lost over 200 killed and

wounded. The revolt was followed by reforms in naval administration, and by the dismissal of about 1,000 men. The Government had difficulty in 1912 in maintaining tranquillity, election disturbances occurring in the state of Bahia in Jan. which required the calling out of Federal troops, and in the autumn disorders threatened in the states of Paraná in the south and Pará in the north.

The death in 1912 of Baron Rio Branco, Brazil's most distinguished Minister for Foreign Affairs, withdrew an influential figure from South American politics. Through his efforts boundary disputes with several of Brazil's neighbours had been amicably adjusted and the territories of the republic considerably increased. He was succeeded as Foreign Minister by Dr. Lauro Müller. In 1913 a protocol was signed with Peru arranging for a commission to survey the frontier in accordance with the Treaty of Demarcation of Sept. 8 1909. On May 9 1913 the plenipotentiaries of Brazil and Uruguay agreed to a convention establishing a new frontier line between the two republics on the river San Miguel, and recognizing Brazil's navigation rights on that stream.

A perennial difficulty was that of national finance. In spite of annual messages of the President to Congress urging economy and the re-establishment of a financial equilibrium, public expenditures increased in alarming proportion to receipts, resulting in heavy deficits. In 1913 the financial stringency was increased by a sharp decline in the price of rubber and coffee, and the result was an industrial and commercial crisis, intensified by the outbreak of the World War in 1914. A symptom of the financial situation was the failure of three railways in the rubber district, with liabilities of £5,000,000, held mostly by French investors. The war reacted seriously on most of the Hispanic-American countries, due to the fact that they had looked to Europe for their financing, and that the belligerent countries included those to which they had shipped a very large percentage of their raw products. In Brazil the reduction of exports and imports (the latter in the second half of 1914 were two-thirds less than in the corresponding period of 1913), and consequently of customs receipts, together with the closing of the European money market, came at a time when the Government was heavily obligated to local and foreign contractors. As a result the Government defaulted. In Oct. 1914 a funding scheme was announced by which interest on all foreign loans, excepting funding bonds of the 1903 loan, became payable in script for three years, and the redemption of nearly all securities was postponed for thirteen years.

The crisis was complicated by a rebellion in the state of Ceará in Feb. 1914, starting among the rubber collectors who could no longer obtain employment, and led by an ex-priest, Padre Cicero. It quickly reached such proportions that the Federal Government had to proclaim martial law and reinforce the Federal troops at Fortaleza, the state capital. The political opponents of the state president, Col. Rabello, apparently used the movement to get rid of him, and on the Federal Government's taking over the state administration the tension was somewhat eased. The rebels were disarmed and the region gradually quieted. Ominous signs of unrest at Rio de Janeiro at the time of the presidential election in March 1914 led to arrests and restrictions upon the press. As a result of the election, Dr. Wenceslao Braz, who had been vice-president under Marshal Fonseca, became head of the state.

Before the end of 1915 adjustments had been made to new conditions and the economic situation became more normal. New customers were found, especially in the United States, and the high prices prevailing throughout the world encouraged exportation. National expenditure was much reduced, the national revenue increased by over £6,000,000, and a small surplus appeared in the budget, a most unusual state of affairs for Brazil.

In the course of that year there were important developments in the relations of Brazil, Argentina and Chile, the three countries constituting what was already known as the A.B.C. Entente. Dr. Lauro Müller at the end of April paid official visits to the other two republics as well as to Uruguay, to bring about closer

<sup>1</sup> The paper milreis during 1920-1 varied between 5d. and 16d. or \$ .30 and \$ .32. The gold milreis is equivalent to 26.2d. or \$ .546.

diplomatic, industrial and commercial relations. On May 23 a treaty was announced in which the countries of the A. B. C. undertook to submit to an international committee any differences that might arise among them, and not to open hostilities until the committee had concluded its labours. The treaty was ratified by the Brazilian Chamber of Deputies in Oct. 1916. The A. B. C. in the spring of 1914 had offered its mediation in the dispute between the Government of the United States and Victoriano Huerta, provisional President of Mexico. In Aug. 1915 President Wilson invited the A. B. C. Powers, together with Uruguay, Bolivia and Guatemala, to enter into a conference on Mexican affairs, the result of which was the unanimous recognition of Venustiano Carranza as "chief of the executive of the *de facto* Government of Mexico." Brazil also took a prominent part in the Pan-American Financial Conference held in Washington in May 1915, in an attempt to better existing financial conditions in North and South America.

The administration of President Braz, which ended in Nov. 1918, was from a financial point of view very successful. He succeeded in reducing public expenditures, restored specie payment for internal debts, promoted the development of natural resources, and improved the economic relations between Brazil and her neighbours. Prices were high, but industry and commerce prospered, and the excessive demand abroad for Brazilian products so increased exportation that the country was left with the largest trade balance it had ever known. In the national elections of 1918 there was no contest, the sole candidate for the presidency being Sr. Rodrigues Alves, a native of São Paulo and senator from that state, who had been president of the republic in 1902-6. The president-elect, however, was too ill to be inaugurated in Nov., and died on Jan. 15 1919, without assuming office. Another election was held in April to fill the unexpired term, and Dr. Epitacio da Silva Pessoa was chosen. Dr. Pessoa was then in Paris as chief of the Brazilian delegation to the Peace Conference. On his return journey in 1919 he paid official visits to England, Portugal and the United States.

From the outbreak of the World War in 1914, popular sympathies in Brazil had been almost wholly on the side of the Entente Powers, in spite of some annoyance caused by the British "black lists." The German policy of unrestricted submarine warfare announced early in 1917 forced the nation to assume an active share in the conflict. On Feb. 8 the Brazilian Cabinet dispatched a strongly worded protest to Berlin, declaring that the proposed "blockade" was contrary to international law, and that Brazil would hold Germany responsible for any consequences that might ensue to Brazilian shipping. A similar note was sent to Austria. On April 4 the steamer "Paraná" was sunk by a German submarine off the coast of France and several of the crew drowned. On April 10, after an inquiry into the incident, the German minister at Rio de Janeiro was handed his passports. In the crisis Dr. Lauro Müller, minister for foreign affairs, resigned his portfolio, apparently feeling that his German name and antecedents might embarrass the Government. Sr. Nilo Peçanha, a former president of the republic, was appointed in his place. Rupture with Germany did not involve an immediate departure from neutrality, but with the sinking of another steamer, the "Tijuca," the drift toward war became more rapid. Late in May President Braz sent a message to Congress advising that neutrality be revoked, on the score that unity of action with the United States, now a belligerent, was a tradition of Brazilian foreign policy. On May 29 the Chamber of Deputies unanimously passed a bill authorizing revocation whenever the executive deemed the occasion appropriate. Congress also authorized the seizure of the German ships interned in Brazilian waters, aggregating nearly 150,000 tons. After the sinking of another vessel, the "Macao," a state of war was formally declared Oct. 26 1917. Many anti-German demonstrations took place during the year, especially in Rio de Janeiro, São Paulo and Rio Grande do Sul.

Brazil, considering her immediate resources, gave valuable aid to the Allied Powers. Although the larger units of the navy had not been entirely renovated by the time of the Armistice, destroy-

ers and other small vessels saw active service on both sides of the Atlantic. Many physicians and a few aviators went abroad to be attached to the Allied armies. The Federal Government in Dec. 1917 also promulgated a new military law, by which all citizens of the republic between the ages of 21 and 30 were subject to selective draft. But up to the cessation of hostilities comparatively few had been called out, because the Government lacked the means for adequate instruction and equipment.

As a signatory of the Treaty of Versailles, Brazil was one of the original members of the League of Nations, and became one of the nine Powers represented on the League Council.

(C. H. H.)

**BRÉAL, MICHEL JULES ALFRED** (1832-1915), French philologist (see 4.481), resigned his chair at the Collège de France in 1905. He died in Paris Nov. 25 1915.

**BREMEN**, Germany (see 4.493). Pop. 311,266 according to the census of 1919; in 1910 it was 299,526. The economic life of the city state of Bremen in Germany was, in the period from 1908-14, in a state of high prosperity: The North German Lloyd attained its highest figures of emigrant traffic (107,124) in the first half of the year 1909. The number of emigrants carried was beginning to diminish about the year 1912. In the course of the years 1912 and 1913 the competition of the port of Emden, the construction of which had been completed by the Prussian State, began to make itself felt.

Bremen gradually passed from being a purely commercial city to a development as an industrial city, the result of which was to impose a heavy burden upon the finances of the city state. Towards the middle of 1913, conflicts of interest arose between the North German Lloyd and the Hamburg-Amerika line; the North German Lloyd chose the path of more unobtrusive development of its business. The prospects of shipping, and therewith the prospects of the business expansion of Bremen, had begun to deteriorate as far back as the beginning of the year 1914.

The effect of the war was to paralyze almost completely the trade of the city seaport. Bremen was the first of the German states to introduce a tax upon profits (May 1915). Attempts to consolidate the maritime traffic led, in the year 1916, to the establishment of the Bremen association for the import trade. On Aug. 24 1916 Bremen celebrated the return of the mercantile submarine "Deutschland" from its successful voyage to New York.

Conflicts on the subject of the constitution began in April 1917. Bremen was the first town which, after Kiel, entered upon a revolutionary movement (Nov. 6 1918). The Workmen's and Soldiers' Council seized political power on Nov. 14. On Dec. 28 it was decided to arm the proletariat. This was followed, on Jan. 10 1919, by the formation of a Socialist republic of Bremen with a council of commissaries of the people. On Jan. 28 1919 the Government of the Reich sent troops to deliver Bremen from the domination of the communists. This force entered the city on Feb. 4 after protracted negotiations. Elections were held for the Bremen State Assembly on March 9, and a coalition government of the Socialist and non-Socialist parties was formed. The new constitution was passed on May 11 1920. It conferred upon the Senate (as in Hamburg) political and administrative powers. Side by side with the democratic Parliament the following representative bodies were likewise established:—A chamber of the working classes, a chamber of salaried employees, a chamber of agriculture, a chamber representing the retail trade, and a chamber representing the large commercial and wholesale interests. The constitution of Bremen contains a special declaration that the Church is separated from the State.

(O. Kr.)

**BRENTANO, LUDWIG JOSEPH** [called Lurjo] (1844- ), German economist (see 4.496), was one of the German delegates sent over to London in Nov. 1919 to attend the economic conference convened by the "Fight the Famine" Council. At the first session of the conference, held at the Caxton Hall Nov. 4, he urged the organization and encouragement of German industry to enable Germany to fulfil her treaty obligations. His more recent publications include a pamphlet on the proposed League of Nations, and two short works, *Ist das System Brentano zusammengesbrochen?* and *Russland, der kranke Mann* (both 1918).

**BREST LITOVSK, BATTLES ROUND, 1915.**—The operations round Brest Litovsk (see 4.500), from July 15 to Aug. 26 1915, formed an important part of Mackensen's campaign in Poland.

in the north-eastern offensive of the Central Powers that year (see EASTERN FRONT CAMPAIGNS).

On the completion of the regrouping of Mackensen's group of armies, which now consisted of the Austro-Hungarian IV. Army, the German XI. Army, the German Army of the Bug and the Austro-Hungarian I. Army, the Central Powers had resumed the offensive along the whole front from the Bug to the Pilica. Mackensen, with three of the armies, was to direct the attack between the Vistula and the Bug. The main body of the I. Army was to coöperate in this attack on the eastern flank by delivering an assault in the direction of Vladimir Volinski, while the remainder of the army was to provide cover along the Bug up to the N. wing of the II. Army. The II. Army and the Southern Army were to cover the attack on the Upper Bug and the Złota Lipa, and were themselves to attack only if this became necessary for the protection of the neighbouring armies or if the Russians showed signs of any dislocation of their forces. Woyrsch was to fall in with the IV. Army's offensive between the Vistula and the Pilica and, if occasion arose, to attack across the Vistula. Forcing the Dniester, the VII. Army was to push forward E. of the Strypa towards Czortkow and Buczacz, and to let its cavalry attack in force E. of the Sereth.

*Battles of Sokal, July 15-24, and Krasnostaw, July 16-9.*—On July 15 at 11 A.M. Mackensen's attack began. On the very first day Fuballo's army made its approach all along the Bug, which, in spite of the high water-level, was forced on the 16th by a division of the I. Corps N. of Sokal. By that time the Army of the Bug had obtained possession of the positions between Terebin and Grabowice, and Arz's Corps, on the right wing of the XI. Army, had stormed the very obstinately defended positions at Skierbieszow. The Guard Corps and the XXII. Res. Corps won the heights to the S.W. of Krasnostaw. The IV. Army was working steadily up to the Russians' strong main position. In spite of the dogged resistance of the Russians the Guard of the XI. Army succeeded in taking Krasnostaw in the next few days, and in pushing on to the heights N. of the Żolkiewka. The I. Army meanwhile had taken Sokal, which was stormed by its I. Corps, and had constructed a bridge-head on the E. bank of the Bug. Farther N., Saurmay's group gained the right bank of the Bug at Zdzary, and, on the S. wing, portions of the II. Corps the E. bank at Krystynopol.

Mackensen's right flank now appeared to be adequately protected, but for the present the attack on Vladimir Volinski was impracticable, on account of the Russian counter-attacks which soon developed and the limited strength of the I. Army. West of the Vistula, Woyrsch and the army group of Kövess, which had been placed under him, had on the 16th begun an attack which led on the following day to the battle of Siemno of which the object was to break through the Russian lines.

On the 18th this attack ended in a complete victory. The Russian IV. Army evacuated its positions along Woyrsch's whole front, and retired to new defensive positions behind the Jłzanka and S.W. of Radom. But here again the Russians were unable to stand against the powerful forward push, and were thrown back beyond Żwolen by the right wing after heavy fighting. While Kövess on the 20th was occupying Radom and advancing victoriously along the E. bank of the Pilica, the front N. of Żwolen was successfully pierced over a stretch of 2 km., and the Russians were driven back to the Vistula and to a kind of bridge-head position S.W. of Ivangorod. But on the same evening Woyrsch broke through these positions also, E. of Zalsay and at Czarnolas, and took possession of the heights at Janowice. All attacks launched by the Russians from the fortress zone at Ivangorod proved fruitless. Farther N. the Russian II. Army, being pursued by the German IX. Army, fell back on Grojec and Blonie and the defences of Nowo Georgievsk.

The successful battles of the XI. Army, the obstinate attacks by the IV. Army, and, not least, Woyrsch's menacing position on the left bank of the Vistula, induced the Russians, although they had obtained all the reinforcements available, to retreat on the 19th. Pursued by the Army of the Bug, the IV. and the

XI. Armies, they once more took a firm footing in new and well-prepared positions on the heights N. of Grubieszow, Rozana, Gardzienice, and N. of the Chodel, thus covering the railway line Ivangorod-Lublin-Chelm. In the days that followed they made all possible efforts, reinforced by the XIII. Rifle Div., to drive the Austro-Hungarian forces at Sokal back across the Bug, but all their attacks, vigorous as they were, failed. All their assaults against the fronts of the XI. Army and the Army of the Bug—whose right wing had gained ground beyond Grubieszow towards the N.—were also unsuccessful, and they were driven back from the heights N. of the Chodel by the IV. Army along a front of about 40 kilometres.

The general effect of these successes on the allied attack was to bring about a short pause in the fighting. The Russians had established themselves in strong positions, and brought up fresh forces. It seemed equally urgent to overhaul the allied forces, and fresh preparations were also necessary before the renewal of the attack. While the pause lasted the allies strengthened their positions against new Russian counter-attacks.

Within the next few days the right wing of the Army of the Bug pushed forward up to the carriage road running from Horodlo to Wojslawice. The Russians renewed their embittered attacks on the bridge-head at Sokal, but without any success whatever. Certain portions of the I. Army succeeded in taking the obstinately defended height of Cora Sokal. The II. Army was able to establish its 32nd Infantry Div. to the E. of Kami-onka Strumilowa on the right bank of the Bug.

Meanwhile Woyrsch's army was making due preparations for the crossing of the Vistula. Kövess's group, the XII. Corps and the 7th and 9th Cavalry Divs. remained beside the Vistula from Janowice to the Pilica estuary, while the Landwehr Corps with the Bredow Div. moved behind the left wing of the army. Aided by the self-sacrificing efforts of the Austro-Hungarian and German pioneers, who suffered many losses through the heavy artillery fire, the Landwehr Corps and the Bredow Div. crossed the river on the 28th in five places between Kobylnica and Tarnów, fighting fiercely, and established themselves at Maciejowice on the opposite bank.

*Battles of Chelm (Kholm) and Lublin: Capture of Ivangorod and Warsaw (July 29-Aug. 4).*—On the 29th the offensive was resumed on Mackensen's whole front. The main blow on Biskupice was to be delivered by the XI. Army, on whose right the Army of the Bug was to continue the attack on Chelm. The IV. Army was to coöperate with the attacking group of the XI. Army by pushing its strong right wing through to Lublin.

The assault, led by Gen. von Emmich, broke through the Russian front in the battle of Biskupice (July 29-30), and an advance was made to beyond Olesniki, where the right bank of the Wieprz and the bridge of the railway leading to Chelm were taken. North of Krasnostaw the Guard Corps joined in the battle, but without winning any immediate success. The IV. Army was for the time being able to come only as far as the Russian wire entanglements.

In consequence of the reviving offensive, and also probably of the ever-increasing pressure of the German armies on the Bobr-Narew front, the Russians once more evacuated their positions E. of the Vistula early on the 30th, their only stand against the pursuit being made at Grubieszow. The XVII. Corps of the IV. Army, after overcoming the seven-fold wire entanglements, made five successive assaults on the Russians during the night of the 30th. In the afternoon the cavalry of the XVII. and IX. Corps rode into Lublin unopposed. The XIV. Corps advanced to the heights N. and N.E. of the town, and the IX., X. and VIII. Corps captured the heights S. of Snopkow and approached the road running through Markuszów Konskowola and Nowo Aleksandrya. On the following day these successes were everywhere extended by violent fighting. In the IV. Army the German 47th Res. Div. at Kurow flung itself across the road named above, and the left army wing reached Nowo Aleksandrya.

On Aug. 1 the Russians continued their retreat step by step, losing heavily. They also left the Bug below Krylow. In the

pursuit Puhallo's whole left wing pushed forward over the Bug below Zdzary, and up to the hollow S. of Ustilug. The Army of the Bug established itself along the Bug from this point to Dubienko, while the Beskiden Corps, fighting on its left wing, pursued the Russians beyond Chelm. The XI. Army came upon fresh position in the line Kulik—Leczna, and in front of the IV. Army the Russians were able to maintain the positions to which they had retired after the abandonment of Lublin.

West of the Vistula great events were in preparation at this time. Kövess's Transylvanian troops captured, by a vigorous attack on Aug. 2, eight concrete entrenchments on the front of Ivangorod, of which four were taken by the 50th Infantry Regt. The Landwehr Corps, too, penetrated into the enemy's positions at Domaszew. The successes of this group assumed for the Russians an ever more threatening aspect. On the one hand the railway between Warsaw and Ivangorod would be in serious danger if the Landwehr Corps pushed their advance any farther; on the other the enveloping of Ivangorod's N. front would admit of considerable pressure being brought to bear on its defenders.

In the next few days Mackensen's group of armies by their tenacious attacks ousted the Russians from one position after the other. The forces of the Russian III. and IV. Armies, which were being hemmed in more and more closely, tried in vain by counter-attacking to obtain breathing space and relieve the pressure.

While Mackensen continued his irresistible advance between the Bug and the Vistula, and Prince Leopold of Bavaria and Woysrch were on the point of taking Warsaw and Ivangorod, there were signs in the N. also that the fortresses on the Bobr-Narewfront were doomed. Pultusk and Rozan had been taken by Gallwitz's Army, and Ostrolena was seriously threatened. Farther N. the VIII. Army (Scholz's) was equipping itself to attack Lomza and Ossowiec, while the X. Army (Eichhorn's) and Below's Army of the Niemen were advancing on Kovno and Riga. The Russians were, no doubt, considering the abandonment of their front on the Vistula; and they had begun to send off their war material and the enormous food supplies needed to support the armies during a retreat which was to be only gradual. But in spite of all the strength they displayed they were being constantly forced backward. On the 3rd, Leczna was captured by the left wing group of the XI. Army. The cavalry of the I. Army entered Vladimir Volinski, and Szurmay was nearing the Luga. Aug. 4 crowned all previous successes. The German IX. Army under Prince Leopold of Bavaria threw the Russians out of both the outer and inner ring of Warsaw's forts, and, after the Russians had evacuated the town and withdrawn to Praga on the right bank of the Vistula, made their entry into the town. Simultaneously the western quarter of Ivangorod on the left bank of the Vistula was taken by the XVI. Infantry Div. of Kövess's group, while the garrison retired to the right bank and blew up the Vistula bridge.

The IV., XI., and Bug Armies, continuing the pursuit, forced back the Russians, in spite of violent resistance, behind the line Sawin—Bazanówka—Kurów. The left wing of the IV. Army advanced to the heights N. of Konskowola.

*The Battle at Lubartow, Aug. 5-8.*—When the Russians began their retreat from the Vistula position between Warsaw and Ivangorod it fell upon Mackensen to deliver his blow on the left flank of the retreating army. His desire was to push forward with all possible speed beyond Parczew to the railway line running from Warsaw to Brest Litovsk. The I. Army and the Bug Army were to cover the attack by holding the bridge-heads constructed on the E. bank of the Bug. The Bug Army removed its right wing to Dubienka and was to advance with its left on Wlodawa and across the Wlodawka. The IV. and XI. Armies, whose attacks were to be continued, were to reach the Tysmienica and Wieprz section as quickly as possible. As a guiding line for the inner wings of both armies Mackensen selected the river bed of the Wieprz.

The shifting of the XI. Army, which now became necessary, was made possible by the transference of the Beskiden Corps from the Bug Army to the rear of the XI. Army's right wing.

The troops occupying the stretch of the Bug below Ustilug could now gradually loosen their hold, for here the Russians, under pressure of what had occurred, were retiring by successive stages on Kovel. They were being pursued for the moment only by the I. Army cavalry.

On the IV. Army devolved the task of attacking the strong positions at Lubartow within the next few days. By the 6th it was able to take the Russian trenches S. of that place, and at Brzostowka and Krasny German troops penetrated into the Russian positions. On the 7th the decisive blow was given by the attacking group on the army's right wing, composed of seven divisions of the XIV. and XVII. Corps, commanded by Lt.-Field-Marshal Roth. The enemy was driven out of several lines, lying one behind the other, during the morning, and in the afternoon and evening this group, with the XXI. Honved Infantry Div. and the XI. and III. Infantry Divs., pushed their way to beyond Firley, driving a wedge into the Russian front. The Russians fell back in complete disorder across the Wieprz. Meanwhile the X. Infantry and XLV. Light Infantry Divs. had crossed the Wieprz to the N.E., at and N. of Baranówka, in order to join in the battle of the XI. Army, which was also being assisted by heavy artillery fire in the direction of Brzostowka. West of the Rudno-Kamionka road the XVII. and IX. Corps also joined in. Here the Russian XXV. Corps had advanced from the area S. of Michów to a counter-attack on the Austro-Hungarian X. Corps, which after a hard struggle succeeded in forcing the enemy back to the Lower Wieprz and snatching from him some of his *points d'appui*. The immediate effect of these battles was the evacuation by the Russians of the Vistula bank N.W. of Ivangorod also. Thereupon Kövess and Woysrch took up the pursuit on both sides of the Solow-Zelechow road. On the 8th and 9th the pursuit of the hurriedly retreating enemy was vigorously carried on. The IV. Army crossed the Wieprz close to its estuary and also at Leszkowice. On the 9th, too, the Bug Army and the XI. Army penetrated the enemy's lines at several points after extremely heavy fighting, but on the 10th they again encountered the greatest resistance.

Woysrch and Kövess crossed the Warsaw-Lublin road and went in pursuit of the Russian IV. Army, which was falling back on Luków and Radzyn. The Archduke Josef Ferdinand's Army now advanced also on the N. bank of the Wieprz, and, on the 10th, reached the region N.W. of the Lower Tysmienica and the area in the bend of the Tysmienica; the Emmich group, fighting on the left wing of the XI. Army, approached the Upper Tysmienica in its pursuit of the Russian IV. Army's left wing. On Woysrch's left were the German IX. and XII. Armies, the latter of which, coming from Gallwitz's Army, had penetrated to the Bug and the area of Sadow, Kaluszyn, and Ceglow. Up to Ossowiec all the fortresses of the Bobr-Narew line had fallen. Novo Georgievsk alone still held out, but around it Gen. von Beseler was drawing his siege-ring ever closer.

*The Brest Litovsk Offensive.*—The IV. Army's flank attack on the Russians retreating eastwards had in the last few days changed into a frontal pursuit in a north-easterly direction, carried out in conjunction with Prince Leopold of Bavaria's group of armies. For the XI. and Bug Armies, however, Mackensen still held to the proposed flank attack, to be delivered in a northerly direction.

The S. wing of Hindenburg's group of armies (the German VIII. and XII. Armies) and the two groups of Prince Leopold of Bavaria and Mackensen were forcing back the Russian main force ever farther towards the Bialystok-Brest Litovsk railway line. This main force was composed of the XII., I., II., IV., and III. Armies, and counted roughly 60 infantry and 7 cavalry divisions. Mackensen's part in the great scheme of operations was to attack the southern portion of this section of the railway, which had the support of the powerful Brest Litovsk fortress. Within the area which it sheltered, down the Bug as far as Janów, the Russian III. Army, with about 14½ infantry and 2 cavalry divisions, made its retreat, while the Russian IV. Army took the direction of Janów and approached the Bug from the north-west. On the 12th the III. Army, between the Bug and

the Tysmienica, gave up the resistance and fell back step by step through Macoszyn, Hola and Parczew, followed by the XI. Army and the left wing and centre of the Bug Army. The right wing of the IV. Army remained in the bend of the Tysmienica, the centre and left wing crossed the Bystrzyca and came towards the Bialka section and Radzyn. Kövess and Woysrch advanced by way of Luków and Siedlec.

As the offensive progressed the allies' front had become considerably shorter. For whereas the length of front in the middle of July, at the beginning of the offensive, had been about 720 km. from the German VIII. Army's left wing at Ossowiec to Mackensen's right wing, it had by the middle of Aug. been curtailed to the extent of 480 km. The armies drew closer together, and it thus became possible to relieve the fighting troops more frequently and also to withdraw whole corps and throw them into the battle at another point.

On the 13th the vigorous pursuit S. and W. of Brest Litovsk gained considerable ground. The IV. Army advanced in the general direction of Biala, the XI. steered straight for Brest Litovsk and fought its way to the region round Opole, and the Bug Army pushed forward its left wing as far N. as Hanna on the Bug. On the following day the Russians offered renewed resistance, but fell back again still farther early on the 15th, after the Guard Corps, reinforced by the XIX. Infantry Div. and the X. Reserve Corps, had penetrated their lines S.E. of Razwiedowka and at Gorodyszczce respectively on the 14th, and the IV. Army had also successfully attacked their positions. The German X. Corps came in to reinforce the ever-lengthening front of the Bug Army and, taking up its position on the army's right wing, undertook the protection of the Bug in conjunction with the I. Army at Dubienka.

On the 15th the XI. and IV. Armies reached to Tuczna and the area S. of Biala in their pursuit. The left wing corps of the Bug Army gained the cross-roads N.W. of Slawatyce. Early on the 16th portions of the IV. Army crossed the Krzna hollow and established themselves N. of the road leading westward from Biala. To the N. of the IV. Army Prince Leopold of Bavaria's group of armies, with Woysrch's Army and the Kövess group, reached the Bug N. of Konstantynow, and the IX. Army crossed over in the direction of Leniatyce.

On the 17th the XI. Army had come up so near to the outlying positions of Brest Litovsk that the Guard and the Austro-Hungarian VI. Corps, who were to invest it, could now move into the blockade position S.W. of the fortress on the line Okczyn-Dobryńka-Lachowka. The X. Reserve Corps established itself E. of Janów on the Bug, and the XXII. Reserve Corps pushed in between that corps' right wing and Lachowka on the front facing east. At Wlodawa the Bug Army built out a bridgehead. The main body of the IV. Army was echeloned N.W. of Janów and crowded together on the S. bank of the Bug. The left wing was opposite Niemirów, where the VIII. Corps was fighting its way across the Bug. Adjoining was Kövess, who had taken the N. bank of the Bug between Niemirów and Mielnik, and was continuing the advance in conjunction with Woysrch and with Prince Leopold of Bavaria's group of armies, which had reached Zerdzyce.

The Bug Army, to which Arz's Corps had been added, and which now stretched as far as Krzna with its left wing, took the offensive across the Bug in a N.E. direction starting from the Wlodawa area. In the battle of Wlodawa the German I. Infantry Div. broke through the Russian positions on the 19th and pushed forward, followed by the XXII. Infantry Div. to Piszczka. The XXIV. Reserve Corps attacked Dubok and Czarsk—for the time being without success. At Slawatyce on the E. bank of the Bug the Russians put up a very strong resistance. They were concerned at this point to delay the advance as long as possible.

The Russian XXIX., XXIII., and II. Caucasian Corps were to take advantage of the protection of the lakes E. of Wlodawa to bar the approach to Brest Litovsk: But the retreating movements of their train columns, and the withdrawal of troops in the general direction of Kovel, Kobryn and Pruzany,

pointed to a fight to gain time, which would have to be cut short, by the I. Army and the Bug Army in a vigorous attack. On the N. wing of the Bug Army no change took place that day as regards the Russian positions at Brest Litovsk, but the XI. Army gained ground N. of the Krzna in the direction of Kolczyn. The Russians attempted, by repeated counter-attacks, to delay the pressing pursuit of the allies until they should have had time to cross the Bug. The IV. Army succeeded in advancing as far as the Pulwa.

In face of the right wing attacks of the Bug Army the Russians had established themselves on the 20th along the Kapajowka. Arz's Corps, before Brest Litovsk, forced the Russians back on both sides of the road leading from Biala to the fortress, to beyond the area N. of Dobryńka. In the zone of the XI. Army the angle of the Bug at Krzna was almost completely cleared by the XXII. Corps. The X. Reserve Corps pushed across the Bug at Ogodorniki without meeting with any great opposition. The Archduke Josef Ferdinand's Army and the Kövess group encountered renewed violent resistance on the line Wolczyn-Wolka-Tymianko. After hard fighting the Russians were driven farther back. The investing troops of Brest Litovsk also gained some ground.

On the 22nd the XLI. Reserve Corps of the Bug Army, after making their way through the lake defiles, reached the region E. of Orzechowo, and on the 24th, together with the XXIV. Reserve Corps, advanced to the line Zbunin-Mielniki after fierce fighting. The Beskidien Corps and Arz's Corps meanwhile were working their way step by step up to the particularly powerful positions and forts of Brest Litovsk. The XXII. Reserve Corps and the X. Reserve Corps of the XI. Army were also fighting hard to repulse the Russian counter-attacks. On the 24th Arz's Corps and the Beskidien Corps succeeded in penetrating the Russian lines in several places and in forcing back the Russian garrison (III. and V. Corps) behind the permanent ring of forts. In the meantime the XI. Army, fighting furiously, advanced over the Bug to the line Nęple-Minkowice, and threatened the fortress from the north. Meanwhile the XII. Corps of the Kövess group had broken through the Russian front, already greatly shaken, at Riasno, and had wrested from it the Pulwa position. A vehement fighting pursuit was carried out by the IV. Army and Leopold of Bavaria's Army group as far as Minkowice-Babinka. The S. wing of the German XII. Army pushed forward with the IX. Army to the swampy valley of the Orlanka.

*Capture of Brest Litovsk (Aug. 25-6).*—On the 25th the XXXIX. Honved Infantry Div. of Arz's Corps broke through the outer ring of forts at Kobylany, S.E. of the railway leading from Biala, and took the fort from the rear. The positions on both sides of the road coming in from Biala were also stormed. The XII. Infantry Div. of this corps captured a fort S. of Korozsoczyn, and the XXII. Reserve Corps took the place itself and several forts on the N. front of the fortress, after which the Germans advanced to the railway bridge and drove the Russians back into the citadel.

Farther N. the Guard Corps and the X. Reserve Corps pushed the Russians back to the Lesna, which river was crossed, by the Guard Corps on the 25th to the N. of Brest Litovsk. The IV. Army and Prince Leopold's group beat the Russians back to Kamieniec Litovsk and the Lesnaja marshes.

After the hard battles fought on the 25th around the forts of the fortress, which culminated in the capture of the redoubt by the XXII. Reserve Corps and Arz's Corps, the Russians, on the 26th, abandoned the fortress and withdrew to the Ryta and the Muchawiec section, closely pursued by the Bug Army and the XI. Army. In the Bug Army the XLI. Reserve Corps and XXII. Infantry Div. pushed forward on both sides of the road from Wlodawa to Kobryn, to beyond the road leading E. from Brest Litovsk. Gerok's Corps gained the Ryta section, and the Beskidien Corps, advancing along both sides of the road from Brest Litovsk to Kobryn, reached the Szebryn region. The VI. Corps remained in the fortress and was once more put under the XI. Army command. The XI. Army advanced in the area



N. of Brest Litovsk as far as the line Saki-Poliszczce, and by hard fighting drove out the Russian rearguard. In the IV. Army, portions of the XXXVII. and XLI. Honved Infantry Divs. had occupied a sort of bridge-head position E. of Kamieniec Litovsk on the Lesna. The main body of the army (the VIII. and XVII. Corps) concentrated at Monaczki and Zadworzany in readiness to withdraw bodily from the front as soon as its troops stationed E. of the Lesna should be relieved.

The fall of the Brest Litovsk fortress and the simultaneous capture of Bialystok by the German VIII. Army compelled the main force of the Russian N.W. front to retreat.

*The Austro-Hungarian I. Army's Offensive at Kovel (Kowel).—*The arrival of the reinforcements transferred from the IV. Army (the IX., X., and XIV. Corps) to the I. Army gave the signal for a renewed offensive advance by the I. Army. If an advance in the direction of Kovel were made, and the Russians were driven E. and W., the result would be to divide the Russian N.W. from the S.W. front. The impassableness of the Polesic, lying between the two fronts, was an appreciable aid to this separation. The offensive was opened on the 19th against the Russian XXXI. and IV. Cavalry Corps by Heydebreck's Cavalry Corps, of which the Austro-Hungarian IV. Cavalry Div. reached the Dubienka area and the XI. Honved Cavalry Div. the locality of Luboml. On the 20th, in a further advance, the German V. Cavalry Div. reached Bobly, and the Austro-Hungarian IV. and XI. Olesk and Ruda, while infantry detachments of the IX., X., and XIV. Corps followed, moving concentrically up to Mokrec and Luboml.

On the following day the Russian XXXI. Corps took up a position to meet them on the line Turyjsk—Nowosiolka—Ruda, whereupon the whole II. Infantry Div. was brought forward to Solowiczce. On the 22nd, together with the Cavalry Corps, it engaged in fierce fighting at Maciejowa and Turyjsk, and drove back the XXXI. Corps on Kovel. The main body of the Russian XXXI. Corps attempted to join the Russian III. Army to the N. by way of the Pripet. The Russian IV. Cavalry Corps was aiming at a similar junction through Kamien Kaszyskiy. In their retreat the Russians had undertaken a regrouping of the N.W. front's S. wing in the area N. and S. of Polesic. The XIII. Army, which had been fighting on the S. wing, was disbanded. The army command with three of the corps were transferred to other fronts, and the remaining four corps incorporated with the III. Army defending Brest Litovsk.

On the 24th the German V. Cavalry Div. and the Hungarian XI. Honved Cavalry Div. took up the pursuit to the N., the IV. Cavalry Div. to the east. The separation of the N.W. from the S.W. front had been accomplished. Up to the end of Aug., Mackensen, who after the fall of the fortress had again been placed under the Supreme Army Command, carried the pursuit up to Kobryn and Pruzany; Prince Leopold of Bavaria's and Hindenburg's S. wing (the XII. and VIII. Armies) advanced along the roads to Wolkowica and Grodno on to the line Pruzany—Jalówka—Nowinka Nowydwor and Sopotkinie, and the Austro-Hungarian armies attacked the S.W. front together with the German S. Army.

On the 25th the Austro-Hungarian IX. Corps of the I. Army had begun an enveloping advance against the N. wing of the Russian VIII. Army. On the 26th their offensive was in full swing. The XIV. Corps and the IV. Cavalry Div. advanced on Zydyczyn from Kovel, the IX. and X. Corps won the area N. and N.W. of Lokaczyn by fighting, and Szurmay's N. wing crossed the Bug at Markostaw. By the end of Aug. the main body of the Archduke Josef Ferdinand's army, which had been set at liberty N. of Brest Litovsk, had been brought over to the N. wing of the I. Army. On the arrival of the army command, the two armies, under the Archduke's Higher Command, continued the offensive begun by Puhallo against Luck and Dubno. The advance which followed, with which the II. and Southern Armies were associated in their attack across the Zlota Lipa, led to the Rovno campaign. (E. J.)

**BRETON, JULES ADOLPHE AIMÉ LOUIS** (1827-1905), French painter (see 4.501), died in 1905.

**BRIAND, ARISTIDE** (1862- ), French statesman (see 4.515). Few men in France had gained so much in political knowledge, ability and influence, during the 15 years preceding 1921, as Aristide Briand. The year of the separation of Church and State (1905) marked his entry into the ranks of the coming men in France. His tolerant interpretation of that measure, his desire to bring about a cessation of the bitter strife between old Radicals and the growing body of men who, while remaining Conservative, nevertheless accepted the Republic, marked him out as a man capable of interpreting the signs of the times. At the age of 59 Briand had been seven times prime minister of France. He was first Minister of Public Instruction in the Sarrien Ministry of 1906, and maintained that portfolio in the succeeding Clemenceau Government until Jan. 1908, when, still under Clemenceau, he became Minister of Justice, a portfolio which he resigned to become prime minister on July 24 1909. After a reshuffle he continued as prime minister from Nov. 3 1910 until Feb. 27 1911. He again took office as Minister of Justice in the Ministry formed by Raymond Poincaré on Jan. 14 1912. He followed Poincaré as prime minister between Jan. 21 1912 and Feb. 18 1913, and retained that office under Poincaré's presidency until March 18 1913. He was Minister of Justice in the Viviani War Cabinet from Aug. 26 1914 until Oct. 29 1915, when he again became prime minister, remaining in office until March 20 1917. He succeeded Georges Leygues as prime minister on Jan. 16 1921. (See FRANCE: History.)

By his eloquence and the suavity of his manner Briand earned for himself many soothing nicknames, such as the "charmer," the "siren" and the "endormeur." He had in his command a voice of pleasing resonance and yet capable of humour, and a wealth of gesture and a knowledge of histrionics acquired from his friend the great actor Antoine. These, with a handsome and dominating personality lightened by a very ready and supple intelligence, explain his countless successes at the tribune. They were reinforced by statesmanlike qualities of courage and firmness, and a proper appreciation of the right moment at which to strike or to stroke recalcitrant sections of the community. M. Briand struck hard when, in 1910, he mobilized the railwaymen and thus put an end to the most grave labour trouble that had yet threatened France. Leaving far behind him the bitter doctrines of class warfare from which he started, Briand, in speeches at Perigueux St. Chamond, appealed to the country to breathe the atmosphere of appeasement, to accept the clerical struggle as over, and to work unitedly on sane measures of social reform. He was, in these utterances, seeking to create a centre party of moderate Republican sentiment. The constant labour troubles and the dangerous pandering to the greed of labour which had marked previous Radical administrations made his task easy. It was upon this Republican centre that Briand based his majority. His chief work was done during the World War. He succeeded Viviani at a time of considerable difficulty. The first battle of the Marne had been won, but the second was still to come. He had ambitious desires to bring about the unification of allied war effort which Clemenceau and events alone had the power to achieve. It was under his influence that the first steps towards coördination were taken. He had to fight against the French Parliament's desire to play a greater part in the conduct of the war than that to which it was entitled. He had also to support in conference against British representatives the claims of the Salonika expedition. As Minister of Foreign Affairs he was largely responsible for the entry of Rumania into the war. In 1921 France gave him her confidence as being exceptionally qualified, by spleness of character and firmness in argument, to maintain her claims for national security amid the difficulties encountered in enforcing the Peace Treaty. He attended the Disarmament Conference at Washington in Nov. 1921, and stated the case for his country. (G. A.)

**BRIDGE, AUCTION** (see 4.531).—As the game of Bridge had succeeded Whist among card-players, so in turn after 1908-10 did the first form of simple or "straight" Bridge give way to Auction Bridge—but the second step was the more complete, for

while *Whist* is still played, "straight" Bridge practically died at Auction's birth. Even before 1908 it had long been recognized that the great weakness of "simple" Bridge was the restriction of the trump-making power to the dealer and his partner, and their inability to evade that privilege at will—a ruling which enforced the playing of too many poor hands and the forfeiture of too many good ones. Hence arose the plan of putting up every hand to auction, forcing the dealer to open the bidding, allowing every player a chance to buy the declaration (naming at each bid the suit which he desired to play), and selling it to the highest bidder (or to his partner in the event of that partner having been the first to name the final suit, in which case the second partner was considered merely the "raiser," not the bidder). Bidding continued until three successive players had passed in lieu of bidding, doubling or re-doubling; any player might abandon his original suit and switch to a new suit, to his partner's suit, or even to his adversary's. The bidding having closed, the partner of the buyer became dummy, and the buyer's left-hand adversary became the leader. At first the original suit-values and ranks were retained as at "straight" Bridge, but many vital changes were made. The rubber-bonus was raised to 250. The adversaries of the buyer (hereafter called the Declarant) were debarred from scoring points toward game ("below the line"), taking their profits invariably in the honours-column at 50 a trick regardless of suit. The book for the declarant remained at six; over that he had to take as many tricks as he had bid; if he took more, he could score them all; if he took fewer, he could score nothing except for possible honours—his adversaries scoring 50 for each trick stolen from the contract. The book for the adversaries varied with the size of the bid, being always the number of tricks that the declarant dared lose; it was determined by deducting the bid from seven—in a 2-bid the adverse book was 5, in a 3-bid 4, and so on. In a doubled hand, the adversaries scored 100 for each trick over their book, in a re-doubled hand 200. But if a declarant who had been doubled succeeded in keeping his contract, his trick-points were doubled, he received a 50-point bonus in the honours-column, and an additional 50 points for every trick over contract; if he had re-doubled, each of these 50's was raised to 100, and his trick points went to four times their normal value. Doubling was restricted to one double for each side.

All these points remained in the game as played in 1921, but meanwhile the next move after 1910 was to change the suit-values—competition in the market-place having proved their too great discrepancy, and having shown also that a good spade hand was invariably wasted. The dealer being still forced to bid, his solace for a poor hand was provided by spades at 2 a trick and a stop-loss of 100 honour-points, while good spades were to be bid as "lilies" or "royals" and at 9 a trick. The suits thus ranked: clubs 6, diamonds 7, hearts 8, royals 9, and no-trumps 10—with the merely nominal spade at 2. All went well until certain American players seized the chance to use the low spades as codes, telling their partners the exact make-up of their hands without assuming proper responsibility or risk. It was thus that the first "false" bids appeared. A system of high-spade bids came into vogue in American play ranging from 2 to 7 inclusive, and forming a code ("6-spades," for instance, meant "Partner, take your choice between hearts and no-trumps; I can play either." The point value being but 12, the partner was enabled to make a comparatively low safe bid). Though this became known temporarily as the "American" game about 1912-3, the sobriquet was really unfair to the majority of American players. These false bids received no support in England and they were equally anathema to the majority of American players, though accepted by all the contemporary American writers on the game except one. Miss Florence Irwin immediately waged a vigorous war upon them, and the result was that the system was killed. To accomplish this end, however, the game had to be re-made. Spades at 2 vanished, and spades at 9 took the place of royals, the latter term disappearing. The dealer's refuge in the case of a poor hand thus having been removed, the forced opening bid was also abolished. Three successive passes

still closed the bidding, except in the case of three opening passes, when the fourth player was still given his chance to bid. An entire hand might be thrown. It was thus that the game continued to be played in 1921.

Certain variants were experimented with during 1913-21, but without disestablishing the recognized game of Auction. "Nullos" were an early variant, their object being to destroy the undue advantage of high cards. The nullo-player had to lose tricks on a poor hand—a much harder thing than to win them on a good one. The idea had long been discussed but had been deemed impossible, as no player could contract to lose all the tricks while carrying an exposed dummy of whose make-up he knew nothing when bidding. Miss Irwin evolved the plan of allowing 6 safe tricks to the bidder of 1 nullo, 5 safe tricks to the bidder of 2 nullo, and so on. She became an ardent champion of this difficult and scientific variant, collecting a large following. Mr. Robertson of England also wrote an extremely deep and clever book on nullo, adding much to the sum of knowledge concerning them. But it was a losing fight; the nullo game was far too difficult for most people. Another variant appeared in America under the name of "Pirate Auction," but it never received any official recognition, and died almost before it lived. More support was given in some London and Paris clubs to "Contract Auction" of which the essential point is that no more tricks can be scored toward game than the declarer has contracted to make, a special system of scoring, different from that of ordinary Auction, being adopted; but in 1921 it had still failed to penetrate beyond a limited circle.

In American play, the method of false-bidding was meanwhile revived under the form of a false double. On this system to double any low bid is not meant as a genuine double, but operates as a code. The person who doubles a one-trick bid in any particular suit practically says, "Partner, I have a no-trumper except that I do not stop that suit. Do you?" while the person who doubles one no-trump says, "Partner, I, too, have a no-trumper. Bid 2 in your best suit, for I have general assistance." But here again it would be quite unfair to call this the "American" game, although it is very commonly practised by American players, for many of the best American authorities have been opposed to it. English players had, up to 1921, declined to adopt any such code.

The American laws have always followed the English laws in substance, with one important exception: in England, the total of a bid must exceed the total of the previous bid, or must equal it and contain more tricks; in America, it is merely necessary to equal it with new tricks, or to out-bid it in number of tricks regardless of total value. Thus in 1921, in England, it was still necessary to bid 5 clubs (=30) to out-bid 3 no-trumps (=30) and 6 diamonds (=42) to out-bid 4 spades (=36); whereas in America, 4 clubs and 5 diamonds would suffice. The American laws have also reduced the revoke-penalty to 50 and abolished "chicane," as having no place in a bidding game; and they make a touched card in dummy a played card. The latest English laws, up to 1921, were drafted in 1914; the latest American in 1920.

*Hints to Players.*—A minimum first-round opening bid is: 5 trumps with ace or king at the top, worth 7 points (counting every honour two and every plain card one), and an outside ace or guarded king. A first-round bid that is not an opener may (in the case of great trump-length) dispense with the outside trick. Later-round bids may dispense both with that and with top-trumps; their great requisite is length. No-trumps are bid on three stopped suits (an ace and two guarded honours, two aces and one guarded honour, or even four or more guarded honours without an ace). After an adverse suit-bid, the no-trump bidder must be able to stop that suit.

To raise his partner's bid once a player should hold one "trick" and one "raiser"; to raise it twice, one "trick" and two "raisers"—and so on. A "trick" is any one of three things, and a "raiser" is any one of five—those same three and two additional. "Tricks" are: guarded trump-honours, or side-aces, or side-kings, guarded. And "raisers" are: guarded trump-hon-

ours, or side-aces, or guarded side-kings, or singletons, or blank suits. A plain singleton is one raiser, a singleton ace or a blank suit two raisers each. The "trick" and the first "raiser" should lie in different suits.

The bidder makes his bid, and then counts his losers (reckoning all "guards" as losers and the things which they guard as takers). His partner announces as many necessary raisers as his hand warrants. The bidder then deducts his partner's takers from his own losers, and knows how high a bid the combined strength warrants. *Count losers to bid and takers to raise or double.*

No one should double the only bid he can defeat. One should double any very low bid, nor one that affords an easy means of escape to his quarry. A doubler should hold the *sure book in his hand* (trusting his partner for the odd) and should be practically sure that his double affords his enemy no probable means of escape.

The declarant's scheme of play in any declared trump is to exhaust the adverse trumps and then to make his side-tricks; he foregoes this trump-exhaustion only in the case of a cross-ruff between his two hands, or a quick ruff in dummy. The adversaries' scheme in declared trumps is to make quick aces and kings.

The declarant's scheme in no-trumps is to hold up the control of the adverse suit or suits, and to establish his own as soon as possible, remembering that "length is strength in no-trump." The adversaries' scheme is to withhold as long as possible the controlling card or cards of the declarant's suits, seeking meanwhile to establish their own best suit.

Quick tricks are the motto in declared trumps, slow tricks and continual "hanging-back" in no-trumps. (F. I.)

**BRIDGE, FRANK** (1879—), English musical composer, born at Brighton, Feb. 26 1879, was musically educated at the Royal College of Music, which he entered as violin student in 1896, but gained a scholarship for composition three years later. For many years subsequently he was equally in demand both as composer and as viola player, in which latter capacity he was quite first-rate. Often he was called upon to play the viola in quartets with the Joachim Quartet. Bridge was at one time or other a member, as violist, of the Grimson and the Motto quartets. A vast number of songs were produced by him, but it is as a composer of chamber music for strings that his reputation stands. In this category there are four quartets for pianoforte and strings or for strings alone and a sextet; a phantasy trio; a quartet in E minor, which was crowned by an honourable mention at Bologna in 1906. His sonnet, *Blow out, you bugles*, has been sung ubiquitously. Among the other works of real importance are his orchestral compositions, *Isabella* (1907); *Dance Rhapsody* (1909); a suite, *The Sea* (1912); *A Dance Poem* (1914); a suite for stringed orchestra and *A Lament* for the same; a tone-poem, *Summer*. As a conductor Bridge also established his reputation. In 1910–11 he conducted at the Savoy theatre for Marie Brema, and was at Covent Garden with Beecham in 1913.

**BRIDGE, SIR FREDERICK** (1844—), English organist, composer and conductor, was born at Oldbury, Worcs., Dec. 5 1844. Educated at first at the Cathedral school, Rochester, where his father was a vicar-choral, he became a chorister there in 1850 and 15 years later assistant organist. In 1865 he became organist to Trinity church, Windsor, in 1869 to Manchester cathedral, and in 1873 he was appointed permanent deputy organist to Westminster Abbey. In 1882 Bridge succeeded Turlé as organist and master of the choristers at Westminster Abbey, a post he retained until 1918, when he retired with the title of emeritus organist. In 1890 he was appointed Graham professor of music; in 1896 conductor of the Royal Choral Society; in 1902 King Edward professor of music in London University. He was knighted in 1897, received the M.V.O. in 1902 and was promoted C.V.O. nine years later. Belonging to what has come to be regarded as the "old school," but remaining a popular figure as the organizer of important musical functions, Bridge was a voluminous composer, especially of church music. He has written about a dozen oratorios and *santatas*, many successful glees and part-songs; primers on

counterpoint, organ accompaniment and musical gestures. Also he published *Samuel Pepys, a Lover of Music* (1903); *A Shakespearean Birthday Book* and an autobiography, *A Westminster Pilgrim* (1910).

**BRIDGES, ROBERT** (1844—), English poet (see 4.532), was in 1913 appointed Poet Laureate. Among his later publications were *Ibani Obecuri* (1916) and an ode on the *Tercentenary Commemoration of Shakespeare* (1916); as well as an *Essay on Keats*, several addresses on poetical subjects, and occasional poems during the World War. He also edited *The Spirit of Man* (1916), an anthology in English and French. In the summer of 1920 he originated a letter, subsequently signed by many Oxford tutors, lecturers, professors and some heads of colleges, addressed to the learned world of Germany and intended as an *cirenicon*, which was published in the autumn. Its advisability was the occasion of much difference of opinion in academic and other circles.

**BRIDGING, MILITARY** (see under PONTOON, 22.66).—At the beginning of the 20th century all the armies of the civilized Powers were equipped with pontoon trains of various forms. The European continental nations all had steel boat-shaped pontoons varying in size from the large German bipartite pontoon, which had about 8 tons effective buoyancy, to the Italian high-prowed pontoon specially suited for the swift current of the rivers in that country and capable of carrying lorries when two pontoons were placed stern to stern, and the French and Belgian pontoons, which were somewhat smaller than the British. The British army adhered to the bipartite wooden boat-shaped pontoon, 21 ft. over all in length, 5 ft. 3 in. beam, and 2 ft. 5 in. in depth, with a maximum effective buoyancy, when immersed to within 6 in. of the gunwale, of about 4½ tons. The advantages of the wooden pontoon with waterproof canvas skin, as proved by the South African War, were lightness, quietness for night work, and the ease with which bullet holes could be plugged, or holes caused by shell splinters repaired. On the other hand, the steel pontoons undoubtedly stood the rough handling of active service better, and did not suffer like the wooden pontoons when they had to be stored in the open under a hot sun. They can also be more readily manufactured in large quantities in war-time, whilst the difficulty of obtaining a sufficient supply of thoroughly seasoned material greatly hampered the rapid expansion of the British bridging trains. Taking all considerations into account it seems probable that the next pontoons designed for the British army will be of galvanized steel, somewhat larger and appreciably deeper than the present pattern.

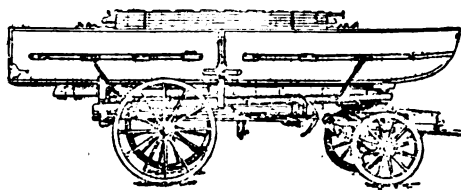

FIG. 11.

The British pontoons (as shown in fig. 11) were made in two sections, the bow section having its gunwale rising towards the bow, and the body curved and tapered forward, so as to reduce the force of the current against the bridge. The stern section was rectangular in form, so that two pontoons could be coupled together stern to stern, or any number of sections could be coupled together to form rafts capable of bearing the weight of the heaviest gun carried in the field. Figure 12 shows the various uses to which the pontoon sections are put in forming light, medium, or heavy bridge. Normally when packed for travelling (as in fig. 11) and when used in the normal form of light bridge designed to take a column of infantry in fours, field guns, and horse transport, the bow and stern sections were coupled together as one pontoon, which could be lifted off its carriage and launched by sixteen men gripping the handles at each side. The wagons carried also the superstructure of timber road-bearers (or "baulks"), which fit on the saddles of the pontoons to form the bridge. "chesses" or planks forming the roadway, and "ribands" or wheel-guides which hold the ends of the "chesses"

secure and form the curb of the roadway. In addition to the pontoon wagons a bridging unit always included wagons carrying adjustable timber trestles known as "Weldon trestles." These were an important part of the equipment, being used to form the piers of the bridge in shallow water near the bank where the pontoons could not float, or to make a landing-stage when the pontoons were used as rafts on a wide river, or without the pontoons to bridge the narrow streams or dry gages.

of carrying infantry in file and pack animals, the equipment could be extended to bridge about double this width.

Bridging trains moving in rear of the army carried each 42 pontoons and 16 trestles with superstructure, as a reserve for the crossing of wide rivers, and these were later supplemented with a superstructure of heavy steel joists, so that the pontoon equipment could be used to form medium and heavy bridges to carry mechanical transport and the heaviest guns and tractors on the road. The pontoon trains were originally drawn by horses, but to save the great number of horses a pontoon train requires, and to give greater mobility, some were adapted for mechanical transport. These consisted of "four-wheel-drive" lorries, each trailing two pontoon or trestle wagons, and were able on good roads to cover much greater distances in less time than the horse-drawn bridging trains.

The "Field Squadrons Royal Engineers" attached to cavalry divisions were equipped with a lighter form of collapsible boat, and each cavalry regiment was provided with an air-raft equipment. A special cavalry bridging train equipped with small steel pontoons was provided for use in Egypt and Palestine. These forms of bridging equipment could take the lighter natures of transport accompanying a cavalry brigade, including horse artillery guns.

On the other hand, the British army when it took the field in 1914 had no reserve of heavy bridge equipment, nor any of the portable steel-girder bridges which were found so invaluable later in the war.

The British army, unlike most European armies, had no specialized bridging units. All the field units of the engineers carried out the annual course of bridging as part of their normal duty. This course was held wherever possible on the banks of a tidal river, and work was mainly concentrated on the pontoon drill which enabled the sappers to handle the material with great celerity. But the training also included practice with various forms of light improvised bridges, and the crossing of rivers by means of barrels, tarpaulin rafts, spar and timber trestles, and the construction of light suspension bridges. Little was done in the way of heavy bridging, but all units were taught the use of spars as derricks and sheers for launching girders and moving heavy loads, and a certain amount of pile-driving and heavy trestle work was done. The officers' theoretical course included the design of timber and steel girder bridges of all types, and some gained practical experience in bridging works in India and elsewhere abroad in the course of their employment in peace on the public works. Never, however, before the World War of 1914-8 had the problem to be solved been of such a varied and complex nature. The immense advance in the use of mechanical transport of all kinds, from motor-cars to steam traction engines, the greatly increased weight of artillery in the field, and finally the coming of the tank, demanded the use of heavy road bridges not far short of railway bridges in strength.

On the other hand, owing to the ease with which destruction can be carried out by means of modern explosives, advancing troops were more frequently than ever before confronted with the problem of crossing a river or canal when all existing bridges had been destroyed, approaches broken up by explosives, and the river and its environs defended by artillery and machine-gun fire. In such a case pontooning was clearly impracticable, and other means had to be devised by which the infantry could be given a footing on the opposite bank to form a bridge-head to cover regular bridging operations.

For these fighting bridges, which were practically the most important because without them no advance could be made, no standard equipment existed. Each field company improvised its own solution to the problem after reconnoitering the crossing to be forced. Usually the material could only be carted to within a mile or so of the site, and had to be carried by hand the remaining distance across shell-pitted ground, or marshland intersected by dykes. Lightness and extreme portability were thus essentials of the design. Then the material might suffer from shrapnel fire whilst *en route* or when lying hidden behind a bank or wall, and might be pierced by machine-gun bullets whilst actually

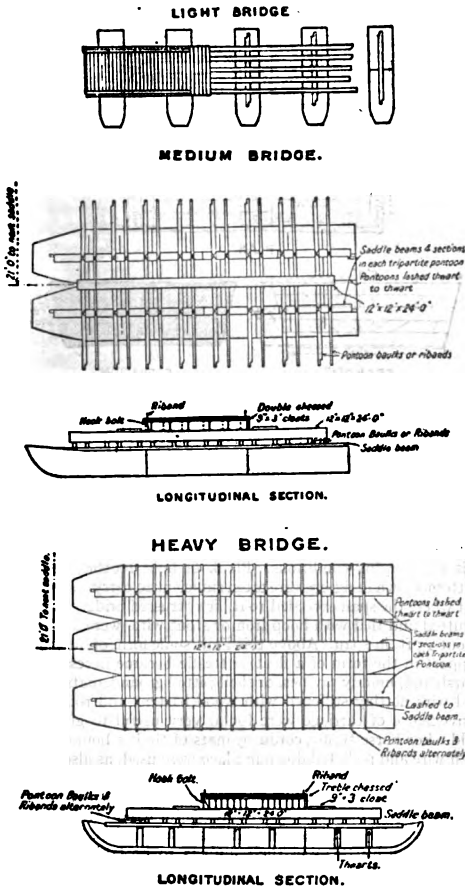

FIG. 12.

In the organization of a British division of 1910-14 were included two, and in the division of 1915 three, "Field Companies Royal Engineers," each of which, besides its other military engineering equipment, included two pontoons and one trestle wagon, the latter carrying two trestles; the three wagons among them carried also five bays of superstructure for light bridge, using five baulks to a bay.<sup>1</sup> This gave every division the means of crossing a river independently, the engineers being able rapidly to form three bridges up to about 75 ft. in length, or one bridge of about 200 ft.; if used to form bridge of half-pontoons capable

The length of bridge section between two points of support technically called a "bay" is normally 15 ft.; thus a bridge supported on the two shore transoms, with piers formed of two pontoons and two trestles, would consist of five bays equal to a span of 75 ft. The width of the roadway of the bridge as normally formed is 9 ft. clear between ribs.

being placed, hence strength and impermeability were required. Lastly, the bridge had to be put together in the dark in perfect silence, exposing as few sappers as possible on the bank, so that simplicity and interchangeability of parts were essential.

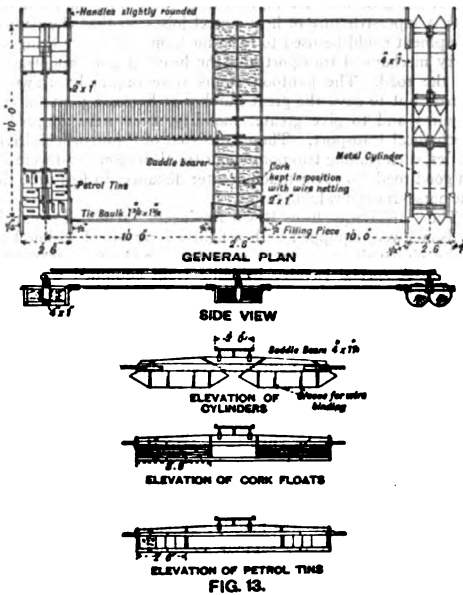

FIG. 13.

The lightest and least vulnerable pattern evolved was probably the cork float footbridge with light wooden footboards hooked over the saddles of the float and interlocking. A pattern of this type is shown in fig. 13, which also shows the employment of captured German canister floats and of petrol tins to support these light footbridges. A petrol-tin raft was used by the engineers of the British 25th Div. for the crossing of the Sambre-Oise canal near Landreocies in 1918; in this case each raft consisted of two floats each of eight petrol tins laid flat and built into a wooden crate for carriage. Eighty of these rafts were carried for 3,000 yd. under fire to the canal bank, and each when launched carried across a man with full equipment. When sufficient men had been ferried across by this means to secure a foothold on the far bank the rafts were connected by light footboards to form a bridge 55 ft. in length.

A form of light ferry-boat which was very useful was made as shown in fig. 14 by tying the standard-size waterproof trench shelter, or bivouac sheet, measuring 13 ft. by 10 ft., over a light wooden framing made in parts for easy transport. In the little boat thus formed six men could squat, and be pulled across by a rope worked by a sapper who had swum to the far bank or paddled across in the first boat; another man on the near bank pulling the empty boat back; and considerable numbers of infantry could thus be put across even before a light footbridge could be constructed. The boats also formed a very serviceable footbridge when connected together as illustrated in fig. 3 (plate). In a case where a crossing could be effected at a canal lock or other point where the width to be spanned was not more than about 20 ft., a light trussed timber bridge was built up complete, and carried or rushed forward from under cover on wheels, and launched across the gap by the sappers, somewhat as a fire-escape is handled. Similar devices have often been used in the storming of a fortress for the crossing of the ditch. A notable example of this method was the crossing at a lock on the Sambre-Oise canal made by the British 1st Div. on Nov. 4 1918.

Another notable piece of front-line work was the construction of a *crib causeway*, built of railway sleepers bolted together and sunk in the bed of the river, to carry tanks across the river Selle in the first line of the assaulting troops (1918). This was kept just below water-level for concealment, and was built in the nights just preceding the attack under the nose of the enemy holding the opposite bank.

As soon as a foothold on the opposite bank has been gained by the infantry, and the enemy's machine-guns put out of action, the next step for the engineers is to establish the crossings more

strongly so that pack-animals can be got across with ammunition and supplies; these pack-bridges usually took the form of rough improvised trestle or pile bridges, but in some cases tarpaulins lashed round a wooden framing were used as floating supports in the same fashion as the waterproof sheets above mentioned.

Note: Framing about 5 x 5 ft. Bottom same form as B but wider.  
 All frames to be lashed together, not nailed  
 4 Carpenters 2 1/2 hours per raft.

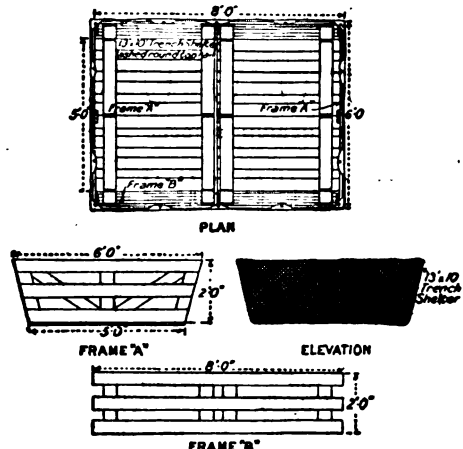

FIG. 14.

For the crossing of minor streams and dykes often met with before or after the main crossing, various devices were used to suit the varying conditions. Plank or light footbridges of the pattern shown in fig. 13 were often sufficient to carry the infantry, but where the span exceeded 10 ft. light trussed bridges of timber, strutted and tied with hoop iron or stout wire, were made up to about 15 ft. in span. Above this limit some form of intermediate support in the form of a float or trestle became necessary. For marshland, muddy ravines, or shell-pitted ground, mats of canvas and wire netting stiffened with wood battens and rolled up for convenience of carriage were found very useful to give a foothold. For horse traffic, corduroy mats of timber bound together with wire and picketed down in place were used, as also were the artillery "trench bridges," 12 ft. in span with timber bearers and 1 1/2 in. flooring, made up in sections 3 ft. 6 in. wide to be laid side by side. These were a little heavy for hand carriage; but in most cases they were issued to the artillery before the advance and carried by them in their limbers to be laid down where required.

Next, it becomes necessary to bring forward the field artillery into position on the far bank. For this work the pontoon equipment is invaluable, as it enables a bridge for horse transport to be made across a river more quickly than it is possible by any other means, and the peace training of the British engineers in pontooning work justified itself in the fire work done, notably in the advance across the Aisne in Sept. 1914. The field companies of the New Army were likewise instructed in and equipped for pontooning work, and the material was used to advantage on nearly every waterway on the entire front in France, on the Piave, on the rivers of Palestine, and in Mesopotamia.

Figure 1 (plate) illustrates the type of bridge built with pontoon equipment across a tidal estuary in which the standard service trestle with adjustable transom is used for the bays nearest the shore; that part of the bridge which will ground on the fall of the tide is carried on barrel-piers strong enough to carry the load when grounded, and the floating portion is composed of pontoons. A "cut" is formed in the bridge by disengaging the central floating portions and allowing it to swing on the tide or stream so that vessels may pass freely along

# BRIDGING, MILITARY

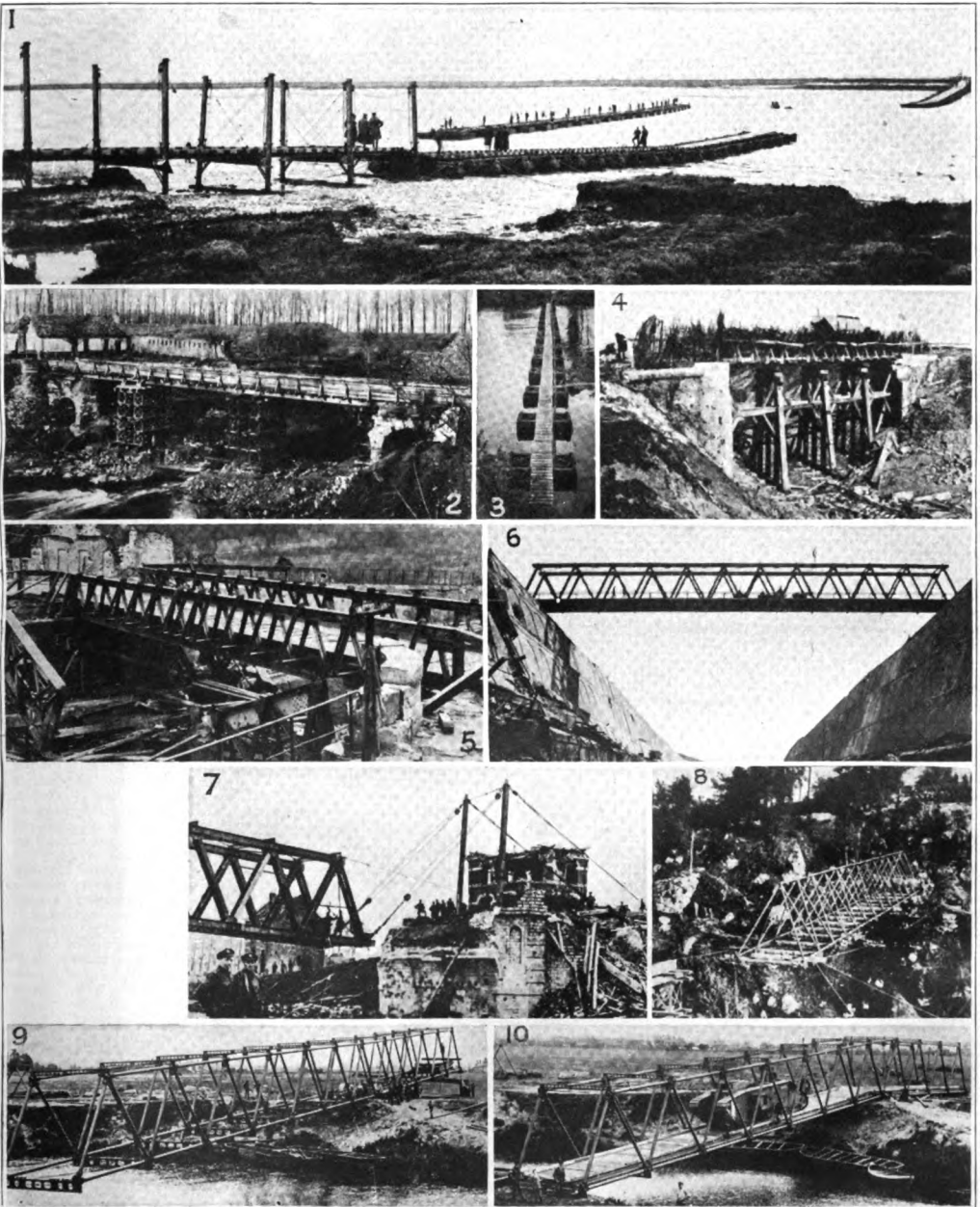

1. Pontoon Bridge with Tidal Ramp and "Cut."
2. Bridge over Moat at Condé.
3. Footbridge Supported on Ground Sheets, Round Frame.
4. High Trestle Bridge.
5. Span Bridge over Escaut Canal on Cambrai-St. Quentin Road.
6. Hopkins Bridge—185-ft. Span.
7. Hopkins Bridge at Point de Nieppe.
8. Inglis Pyramid Bridge.
- 9 and 10. Inglis Bridge.





the channel. The bridge is reformed by pulling up on the anchor cables until the cut portion regains its position in bridge. The pontoon bridge shown is the normal bridge capable of carrying columns of infantry in fours, field guns, horse transport, and light cars up to 2-ton axle loads. Where a pontoon bridge has to be built to carry heavy mechanical transport, siege artillery tractors and other heavy loads it is necessary to use more pontoons and group them in the form of rafts as shown in fig. 12, the medium bridge being designed to carry 8-ton axle loads and the heavy bridge 16-ton. The roadway from saddle to saddle of the rafts is carried by heavy steel joists on which two or three layers of chesnes are laid.

As the pontoon equipment is always required to move on with the army other types of bridge are substituted for the pontoon bridges as soon as practicable, and these in the late war usually took the form of timber trestle bridges of tree trunks or any other timber found available in the locality. For heavy loads these bridges were constructed of stout squared timber as in fig. 4 (plate), and with a roadway carried on heavy steel joists were capable of carrying all traffic. Where the bottom was soft piles were used in place of trestle piers to support the spans, as a trestle is very liable to sink or tip in soft mud or on an irregular bottom and so throw the roadway out of level. Pile-driving is, however, a slow operation, and plant for this purpose had to be improvised in the field, as no satisfactory portable apparatus has yet been standardized for army purposes.

These heavy timber bridges necessarily take some time to prepare and erect and are not very suitable for extreme loads, and after some war experience it became evident that for a general advance on a large scale the army must be equipped with steel girder bridges to carry the heaviest loads, and capable of transportation in small portable sections and speedy erection on the site. Many types of these bridges were designed to suit the various spans likely to be required, and held in reserve ready for dispatch to the most convenient railhead. Bridging schools were formed to train officers and men in the use of this heavy bridging material, and, when the advance came to be carried out, the corps and army engineers were able to replace the light bridges made by the divisional field companies so rapidly that, almost as fast as the fighting troops could gain ground, the heavy artillery, mechanical transport, and all the other heavy traffic were able to follow up.

Where intermediate support could be obtained on firm ground, piers were often built up of skeleton steel cubes 3 in. by 3 in. by 3 in., each capable of supporting a weight of 40 tons and built up with timber crib work to form single, double or treble cube piers as required. A bridge consisting of a series of comparatively short steel spans could then be built on these piers. The bridge of this type illustrated in fig. 2 (plate) has two spans of 30 ft. and one of 18 ft. on piers about 15 ft. in height.

For larger spans a very useful bridge was the 60-ft. span Warren girder of which an example is shown in fig. 5 (plate). The inadequate support given by the abutments of the broken bridge is here reinforced by the use of a heavy timber trestle pier on the towpath.

For larger semi-permanent bridges on the main routes great use was made of the "Hopkins" bridge, which was a girder bridge made in two sizes capable of erection in spans to any multiple of 15 feet. The lighter type was suited to spans of 60 to 90 ft., and the heaviest design for spans over 100 feet. This was normally used for spans of about 120 ft., but in fig. 6 (plate), representing a bridge over the dry Canal du Nord, the span is 180 feet. The loading must of course be calculated according to the span adopted, 150 ft. being the limiting span at which this type will carry 35-ton tanks singly.

The special feature of the design of this bridge is that of great portability, the heaviest piece weighing only 104 cwt., so that the whole bridge may be carried in G.S. wagons if required. Usually, however, the bridge was delivered on site by lorries, the 120-ft. span being carried in 35 lorry loads. The bridge is built up upon the near bank in extension of the centre line of site and all the parts bolted together to complete the two main girders with cross bracing. The construction of the abutments usually proceeds simultaneously with the erection of the girders.

The method of launching this bridge is shown by fig. 7 (plate), which shows a 150-ft. span being got into position at Pont de Nieppe, near Armentières. The flooring, consisting of rolled steel joists as cross girders and longitudinals, with timber decking laid crossways, is added when the bridge is in position.

Another very clever design of bridge specially adapted for the military requirement of speed in erection is the "Ingles" bridge. This bridge in its pyramid form is illustrated in fig. 8 (plate), but the rectangular form afterwards designed is better suited for mechanical transport.

The particular feature of this bridge is the absence of any bolting or riveting of joints. The steel tubes of which the girder is composed have merely to be fitted into the special junction boxes carried on the ends of the transoms and stiffeners, and are held in place by pins secured by split pins. The launching of the bridge is most quickly done by constructing the bridge in skeleton parallel to the river with enough counter-weight on the tail to enable it to be swung on a special trolley or carriage as shown in fig. 9 (plate).

The bridge, when in place, is then lowered from its carriage and decked over, and lastly the tail is dropped to form an approach as in fig. 10 (plate) in which a tank is shown crossing the bridge. This bridge can carry a tank over a gap of 105 feet. Where a wider river than this has to be dealt with the bridge is carried on special heavy pontoons (fig. 15), or four bays of the bridge may be used on three of these pontoons as a raft, which is then warped across the river. The projecting bay forms the landing stage for the tank (fig. 16).



FIG. 15.—Ingles Rectangular Tubular Bridge Mk II combined with the heavy pontoon.



FIG. 16.—A 35-ton Tank being ferried across a river on a raft.

The construction of bridges to carry mechanical transport always involves work on approaches, sometimes of considerable length, to carry this traffic on and off the bridge to the main road, and the officer selecting the site has to take carefully into account the time which will be entailed in this construction, as well as the best span or combination of spans to use for the bridge itself. For instance, on a high level site it may sometimes be advantageous to build several smaller spans supported on timber trestles or steel-cube piers to reach the main span so as to save the delay of filling a high embankment approach. Usually the time for constructing a permanent macadam approach road to the bridge would be too great, and the common form of approach to a bridge for heavy traffic was a road of beech slabbing cut in the forests to a thickness of 2 in., about 1 ft. in width and 10 ft. in length. These slabs were best laid for a single roadway in herring-bone fashion, so as to make a road of about 15 ft. in width, the slabs being spiked to longitudinal sleepers and secured by a heavy timber curb along both sides of the road. It is important that the immediate approach to the bridge should be laid out in true alignment and level with the bridge decking, which also should be as even as possible, so that stresses due to impact are reduced to a minimum, and traffic is able to reach the bridge, and move clear of it without special effort.

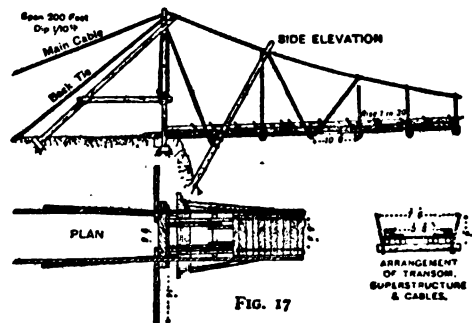

FIG. 17

In mountainous country where pack transport has to be chiefly used, and in theatres of war where still more primitive conditions of transport exist, the field suspension bridge (fig. 17) is the most common form of bridge for any considerable span. Suspension bridges have been built in the field to carry lorries, but usually they are only required for pack or even foot traffic. The best materials to use for the cables are chain or steel wire ropes; but telegraph wires are frequently used, and hemp ropes, thongs of hide, or ropes of creper or grass, have been employed.

Aerial ropeways, too, have been of great value in mountainous countries for the supply of ammunition, stores and water, to save transport up a long steep incline, or as a temporary means of con-

munication across a deep gorge or wide river. Many forms of floating bridges have also been constructed from local boats or barges where the pontoon equipment has not been available.

In uncivilized countries the chief problems for the bridge-builder are to devise the best use to which to put the scanty supply of materials available, and to adapt the local resources of the country to advantage, knowing that the transport difficulties render it impossible to obtain all he would desire. But, great as is the task of bridge-building for an army in undeveloped countries, greater still is the work of reconstruction during an advance in a highly developed theatre of war such as France. There the accumulation of means of attack and defence on a grand scale is made possible by the fulness of the communications, yet at the same time each of these many lines of communication is sensitive at every river-crossing. Almost without exception these bridges are destroyed by the enemy on his retirement, and an army cannot safely push on its advance without its full equipment of battle means and without clear routes for its supply transport. Hence it is no exaggeration to say that in the final campaign of 1918 in France the power of the British army to advance depended on the speed with which the Royal Engineers could construct bridge-crossings and roads.

During the period Aug.—Nov. 1918 no less than 539 heavy bridges were erected on this front alone, of which 326 were standard steel bridges and 213 of heavy timber or salvaged material, not taking into account the innumerable light improvised crossings and footbridges by which the leading infantry were enabled to attack, and the pontoon and light trestle bridges for field artillery and horse transport.

For such a task executive energy, organization and technical skill are equally, and each in the highest degree, necessary. And to these qualities of the military bridge-builder must be added, for the work in the forward zone, that of personal devotion under fire. It is significant that of the Victoria Crosses awarded to officers and men of the Royal Engineers in the World War more than half were won by acts of conspicuous gallantry in the construction and demolition of bridges. (E. N. S.)

**BRIEUX, EUGENE** (1858— ), French dramatist (see 4.563\*), published four plays after 1910: *La Foi* (1912); *La Femme Scule* (1913); *Le Bourgeois aux champs* (1914) and *Les Americains chez nous* (1920). He also wrote some accounts of travel, *Voyages aux Indes et à Indo-Chine* (1910) and *Au Japon par Java, la Chine, la Corée* (1914), as well as a couple of pamphlets addressed to soldiers, one before and one during the World War, during which he devoted himself with particular ardour and activity to the care of those blinded by wounds.

**BRIIGGS, CHARLES AUGUSTUS** (1841—1913), American theologian (see 4.566), died in New York June 8 1913. His last published works were *Church Unity* (1909); *The Fundamental Faith* (1913) and, posthumously, *Theological Symbolics* (1914).

**BRIGHT, JAMES FRANCK** (1832—1920), English historian, was born in London May 29 1832. He was the son of Richard Bright, the physician who first diagnosed "Bright's disease" in 1827, and his mother was Eliza Follett, sister of Sir William Follett, who was solicitor-general and attorney-general in Peel's administration (1834—44). He was educated at Rugby under Dr. Arnold and at University College, Oxford, where he graduated with first-class honours in 1854. In 1856 he was ordained deacon and joined the staff of Marlborough College, and was the first public schoolmaster to organize a modern side. For this purpose he wrote the necessary school-books himself, including his well-known *History of England*. After his wife's death in 1871 he left Marlborough and went to Oxford as a modern history tutor and lecturer at University, Balliol and New Colleges and in 1874 was elected to a fellowship at University and in 1878 to an honorary fellowship at Balliol. In 1881 he became master of University College, and threw himself with vigour into university and City life, becoming treasurer of the Radcliffe infirmary, and founder of the first technical school in Oxford, for which he presented a site. His latter years were spent at Ditchingham, Norfolk, where he died Oct. 23 1920. He also published *Lives of Maria Theresa and Joseph II.* (1897)

**BRINKLEY, FRANK** (1841—1912), British author, was born in 1841. Having entered the British army, he went to Japan in 1867 in command of a battery of artillery. In 1871 he became principal instructor at the Marine College, Tokyo, under the Japanese Government, and henceforth devoted himself to things Japanese. He left the army, married a Japanese lady, and in 1881 founded the *Japan Mail*, of which he was proprietor and editor till his death. He was also correspondent for the *London Times* in Japan. He published *Japan* (1901); *Japan and China* (1903), as well as a Japanese-English dictionary, and was the author of the article JAPAN in the earlier volumes of this encyclopaedia. He held a unique position among foreign residents in Japan, alike as a profound student of its history and art, and as a powerful factor in international politics. He died at Tokyo October 28 1912.

**BRISSON, EUGENE HENRI** (1835—1912), French statesman (see 4.574), was again elected president of the Chamber in 1912, and died at his official residence April 14 1912.

**BRITISH COLUMBIA** (see 4.598).—This Canadian province is traversed from S. to N. by four principal ranges of mountains—the Rocky and Selkirk ranges on the east, and the Coast and Island ranges on the west. The Rocky Mountain range preserves its continuity, but the Selkirks are broken up into the Purcell, the Selkirk, the Gold and the Cariboo mountains. Between these ranges and the Rockies lies a valley of remarkable length and regularity, extending from the international boundary line along the western base of the Rockies northwards for 700 miles. West of these ranges extend the remains of a vast plateau or tableland with an average elevation of 3,000 ft. above sea-level, which has been so worn away and eroded by watercourses that in many parts it presents the appearance of a succession of mountains. In others it spreads out into wide plains and rolling ground dotted with low hills, which constitute fine areas of farming and pasture lands. This interior plateau is bounded on the W. by the Coast Range and on the N. by a cross-range which gradually merges into the Arctic slope.

The area of British Columbia according to the census report of 1911 was 353,416 sq. m. of land, 2,439 sq. m. of water, a total of 355,855 sq. m., and in 1919 was estimated at 395,610 sq. m. *Population*.—The pop. of British Columbia increased from 36,247 (less than 10,000 of whom were whites) in 1871 to 392,480 in 1911. The estimated pop. in 1920 was about 650,000. The Chinese pop. was 19,568 in 1911. Japanese immigration took place chiefly after the restriction of Chinese immigration in 1906: in the census of 1911 Japanese numbered 8,587. It is, however, limited by agreement between the Governments of Canada and Japan to 400 per year. After 1906 Hindus, mainly Sikhs, attracted by the high wages paid to other Orientals, came in large numbers and objection to their immigration was quite as strong as that to Chinese and Japanese. The situation was a delicate one from the fact that these people were British subjects and many of them had served in the British army as soldiers. Their further influx was prevented by diplomatic arrangement. The number of Hindus in the census of 1911 was recorded as 2,292. The Indian pop. was returned as 24,744. Of these all but 1,334 were professing Christians. Although about 750,000 ac. have been set apart and occupied as Indian reservations, not more than 2% of the land has been cultivated. The only Indians of British Columbia who devote themselves to agriculture to any extent are several tribes in Yale and Okanagan districts. The Indians are entirely self-supporting; those of the northern interior sell furs to the various trading companies; those on the coast and southern interior are employed in fishing, in the salmon canneries, and in hop-picking. To some extent they are employed in the lumber woods and in various other capacities. Their education is almost exclusively in the hands of several religious denominations, Methodist, Presbyterian, Anglican and Roman Catholic, whose respective spheres of influence are recognized by the Department of Indian Affairs. The Indians of British Columbia have always been peaceably disposed, largely in consequence of the satisfactory manner in which the Hudson's Bay Co. dealt with them for many years. Several of the tribes on Vancouver I. and mainland coasts and one or two in the interior were at one time regarded as a dangerous element, but they are now quiet and peaceable. The Indians are divided into many tribes under local names, but fall naturally on linguistic grounds into a few large groups. They are made up of the following stocks: Haidan, Tsimshian, Wakashan, Déne (or Athapaskan), Kootenaiian and Salishan. More than 2,000 belong to nomadic tribes whose affiliations are probably Athapaskan. There was for some years a considerable decrease of Indian population on account of the ravages of disease, but it would

\* These figures indicate the volume and page number of the previous article.

appear that it is again on the increase. By origins, the chief elements of the pop. of British Columbia in 1911 were: English 133,186; Scotch 74,493; Irish 40,642; Welsh, etc., 4,362; German 11,880; Chinese 19,568; Indian 24,744; Japanese 8,587; Hindu 2,292; Scandinavian 15,968.

Vancouver, by far the largest city in the province, had in 1919 a pop. of 115,000. Victoria, 84 m. from Vancouver, is the capital of British Columbia, and rests on the most southerly point of the peninsula into which Vancouver I. tapers to the Straits of Juan de Fuca. While it possesses some important industries and is the headquarters of others, it is essentially a residential and social centre, to which the fact that it is the capital city adds much. The Legislative buildings, which form the most striking feature of the city upon entering the harbour, contain fine collections of natural history, mineral, agricultural and horticultural specimens. The pop. in 1919 was 39,500. Three m. from Victoria is the fine harbour of Esquimalt, with a naval dockyard. On Saanich mountain, near the city, is the Dominion Observatory. New Westminster, known also as the "Royal City," 12 m. from Vancouver and connected with it by an electric railway, had in 1919 a pop. of 19,000. It is the centre of the rich farming section of the Westminster district and from its situation on the Fraser river is naturally associated with the salmon-canning industry. It is also largely interested in the lumber business. Nanaimo, popularly known as "The Black Diamond City," is the headquarters of the oldest colliery in the province. In the neighbouring country fruit-growing is carried on extensively, and diversified farming is increasing at a rapid rate. It has a fine harbour and very picturesque surroundings, and is the centre of the herring industry. The pop. in 1919 was 7,800. Prince Rupert is a western terminus of the Canadian National railways. Other towns are Ladysmith, Vernon, Nelson, Armstrong, Kelowna, Enderby, Kamloops, Fernie, Rossland, Revelstoke, Trail, Cranbrook, Kaslo, Salmon Arm, and the two Albernas.

**Government.**—The Government of British Columbia consists of a Lieutenant-governor appointed by the governor-general in Council, an Executive Council of 11 members chosen from the Legislative Assembly, and a Legislative Assembly of 47 members, elected every four years. Every adult British subject who has resided six months in the province is entitled to vote. The province is represented in the Dominion Parliament by 13 members of the House of Commons and 6 senators. Municipal government has been introduced, though a large area is still unorganised.

**Education.**—The school system of British Columbia is free and non-sectarian. In each district where 20 children between the ages of 6 and 16 can be brought together the Government builds a school-house, makes a grant for incidental expenses, and pays a teacher. In cities having charge of their own schools liberal grants are made by the Government. Attendance at school is compulsory from 7 to 14 years of age. In 1919 933 schools were attended by 72,000 pupils. There were 45 high-schools in 1919 with 5,806 pupils, and the Government maintains two normal schools, one at Victoria and one at Vancouver, for the training of teachers. The university of British Columbia, founded in 1908, is supported by the province, and has magnificent grounds at Point Grey, near Vancouver. It had about 900 students in the session 1918-9.

**Finance.**—The revenue and expenditure of the province were respectively \$10,479,259 and \$15,970,877 in 1913-4; \$6,291,693 and \$10,422,206 in 1915-6; (estimated) \$9,868,325 and \$10,800,805 in 1917-8; and \$12,609,960 and \$13,313,303 in 1919-20. The liabilities of the province were \$52,288,067 and assets \$59,642,124 in 1919.

**Agriculture.**—The area of farming land in British Columbia probably does not exceed 10,000,000 ac. and it is distributed in widely separated valleys. Hence agriculture cannot be regarded as a basic industry of the province, although it has made wonderful progress. Owing to the natural conditions small mixed farming is predominant, including fruit-growing, grain-growing, stock-raising, poultry-raising and the growing of roots and vegetables, to which may be added the raising of sugar beets, tobacco and hops. Many tracts sanded fertile by irrigation have been shown to be unusually well adapted to the cultivation of both fruits and cereals, though a large acreage is suitable merely for grazing.

Fruit-growing in the interior is largely restricted to apples which find an extensive market in the Middle West, eastern Canada, and Great Britain. Apples, grapes, apricots, peaches, tomatoes and melons grow to perfection in the southern interior of the province. Small fruits such as strawberries, raspberries, cherries, loganberries, prunes, etc., produce excellently in all parts of the province, but the cultivation of these is largely confined to Vancouver I. and the N. side of the Fraser river on the lower mainland. The principal fruit-growing districts are Vancouver I., portions of Westminster district, Okanagan valleys, and land along the Arrow and Kootenay lakes. Tobacco is grown successfully in the Kelowna district and in Okanagan, which also produces onions. Hops are grown in the lower Fraser valley. Wheat was formerly grown somewhat extensively in parts of the interior but most wheat lands have given place to fruit-growing and mixed farming, and wheat is now grown

for poultry food. Oats is the staple grain crop although barley and other grains are also grown. The rich pastures, the prolific forage crops and pure water are natural conditions which have brought both dairying and live stock into prominence. The raising of hogs is profitable in certain parts and there is a large demand for all pork products. Draft horses are bred extensively and there are many herds of choice cattle especially in the lower mainland and on Vancouver Island. Poultry-raising has attained large proportions, the demand for all kinds of poultry being far in excess of the supply. The yields of the principal field crops in 1920 were: wheat 874,300 bus.; oats 1,663,000 bus.; barley 364,100 bus.; potatoes 2,933,700 bus.; roots 3,220,000 bus.; hay 254,000 tons.

**Lumbering.**—The stand of timber in British Columbia is estimated to be 400,000,000,000 feet. The value of the manufactured timber is about \$30,000,000 annually and it is estimated that the forests are growing faster than they are being cut, so that if properly conserved and developed the timber supply of British Columbia should be inexhaustible. Throughout the coast region, and to a lesser degree in the wet belt of the interior, there are great stands of Douglas fir, hemlock, red and yellow cedar, spruce, large and commercial pines. The Douglas fir, however, is not found farther N. than the northern end of Vancouver Island. The amount of hard woods such as oak, maple and alder is inconsiderable and commercially negligible. Douglas firs, cedars and spruce 8 to 10 ft. in diameter are not unusual in the coast region, while there are individual specimens of Douglas fir 300 ft. high with a girth of 50 to 55 ft. A stand as high as 300,000 ft. to the acre exists in places on Vancouver I. and the coast. Douglas fir, also commercially known as "Oregon pine," is the largest commercial factor. The red or giant cedar is probably the most useful of the trees, nearly every portion of the tree being available for some use, principally shingles, fence posts, telegraph poles and interior finishing. The western white spruce is also very valuable and is employed for various purposes such as box-making, furniture and pulp wood. Saw-mills are located at all the important points of the settled province. There is a constant demand for British Columbia timber in the prairie provinces and quantities are exported abroad. The number of lumber firms reporting to the Dominion Bureau of Industries in 1918 was 301. The quantity of lumber cut was 1,157,636,000 ft. at a market value of \$28,351,207; of this 714,018,000 ft. was of Douglas fir. The total capital invested in the industry was stated as \$12,408,448 and the average number of employees 13,263 to whom \$31,621,118 was paid in wages.

The manufacture of pulp and paper has developed on the coast of British Columbia and is one of the largest and most profitable industries. Pulp is largely produced from white spruce, although hemlock, Douglas fir and other coniferous trees can be used with success. The total production of pulp in 1918 was 173,161 tons valued at \$1,062,724. The principal production was newsprint and wrapping papers. The value of the newsprint was over \$7,500,000 and of the total production \$9,264,705.

**Sport.**—British Columbia is rich in big game, fur-bearing animals and game birds. The principal districts which are resorted to by sportsmen are Cassiar, where moose, caribou and mountain sheep are plentiful; the interior of Vancouver I. is famed for its wapiti, bear and cougar; the Bridge river and Chilcotin districts where the bighorn, mountain goat, grizzly and black bear, mule-deer and, in parts, caribou, are plentiful; the Similkameen district near the International Boundary; E. Kootenay, where E. of the Columbia river there are moose, wapiti, bighorn sheep, mountain goat, several varieties of deer and black and grizzly bears; and the Nelson district. Between Fort George and the Little Smoky river is a magnificent moose country.

The game birds are ducks and geese, both abundant, and grouse, pheasants, quail, pigeons, plover and snipe. The game fish, as distinguished from commercial varieties, are principally trout, spring salmon and steelhead, and are everywhere abundant in their respective habitat.

**Fisheries.**—The chief fisheries are salmon, halibut, cod, colachan, sturgeon, herring, smelts, sardines. The varieties of salmon are Quinnet, Chinook or Tyee salmon, silver salmon or coho, sock-eyes or blue-black salmon, dog salmon, humpback. Next in importance, at least to the angler, are the cut-throat trout, steelhead and Dolly Varden trout (Mahina); all of these are exceedingly abundant. The spring salmon is the first to appear and varies from 10 to 75 lb. in weight. It is largely shipped fresh to the markets. The sock-eye and coho are almost exclusively used for canning, and the dog salmon and humpback, which run in immense numbers, are among the most important sources of supplies for the canneries. Next to the salmon the halibut is the most important commercial fish. It is found all along the coast from Bering Strait to San Francisco, but the chief source of supply in Canadian waters is in Hecate Strait and N. of it. It finds an extensive market in the United States and eastern Canada. Herring run in enormous numbers at certain periods; the headquarters of the herring fisheries are at Nanaimo. The cod, the Cutlus cod, the Alaska black cod or "skil," the red rock cod and other varieties of fish which pass under the name of cod abound all along the coast, and enter largely into the fishing industry. The colachan, smelts, anchovy, and sardines run in enormous numbers and are caught principally for the local market.

Sturgeon, rock fish and shad are other varieties of food fish. The mackerel is unknown on the Pacific coast. A native oyster, locally known as the "Olympian," is found in considerable quantities at many places along the coast of British Columbia and the state of Washington and is edible. The eastern oyster has not been propagated, but young oysters are imported from eastern Canada and successfully cultivated. So far it has not been found practicable to propagate lobsters. The rivers are abundantly stocked with fish, principally salmon or trout, and there are also whitefish and graylings in the northern waters. The whaling industry was established about 1906 by the Pacific Whaling Co. with headquarters near Nootka and has been most successful. The once important sealing industry is now extinct. Only native Indians are permitted to take seals in Pacific waters and as the seals are again increasing in numbers the catch is correspondingly great. Dog-fish are very numerous at various points along the coast and are rich in oil.

The salmon-canning industry is still considerable, but the Fraser river has been much depleted and steps were being taken in 1920 towards conservation. The fishing industry was greatly stimulated during the war and increased in respect of many of the smaller fishes by 100 per cent. Great Britain is the largest market for British Columbia salmon. The values of the varieties caught in 1919 were: salmon, \$17,537,164; halibut, \$4,617,484; herring, \$1,109,870; pilchards, \$371,871; cod, \$368,838; flounders, etc., \$139,940; black cod, \$116,580; soles, \$90,848. British Columbia contributed \$25,301,607 in 1919, almost half of the entire fisheries production of Canada. There were 74 salmon canneries and one other cannery in operation. There were 9 whale and fish oil factories and 20 fish-curing establishments, representing a capital in all fisheries of \$16,358,595. The principal cannery operations are carried on in the Fraser river, Skeena river, Rivers Inlet, Naas river, on the coast of Vancouver I. and in a few outlying districts.

**Mining.**—Mining in British Columbia originated with the placer deposits of the Fraser river and its far-off tributaries in the Cariboo district, from which it is estimated that some \$55,000,000 or \$60,000,000 of gold has been extracted. The undeveloped coal-fields of British Columbia have been estimated to cover 1,351 sq. m., of which 834 are in Vancouver and Graham I. (Queen Charlotte Is.), and 517 on the mainland. Their resources are stated at 3,110 million tons on the islands and 37,115 million tons on the mainland, of which 61 million tons are anthracite, 39,674 million tons bituminous coal and 490 million tons lignite. There are large deposits, as yet undeveloped, of magnetite and haematite iron. New interest attaches to the Queen Charlotte Is. on account of the extensive deposits of oil shale extending along the W. coast of Graham Island.

The mineral production in 1919 amounted to \$33,296,313, made up of gold, \$3,437,145; silver, \$3,592,673; lead, \$1,526,855; copper, \$7,939,896; zinc, \$3,540,420; coal, \$11,337,705; coke, \$637,966; miscellaneous products, \$1,283,644.

**Manufactures.**—Lumber in all its forms is manufactured for home consumption and export in over 200 saw-mills. The Canadian Pacific railway owns and controls large smelting works at Ansoy and at Trail. The coling of coal, manufacture of pulp and paper, salmon canning, sugar refining, and the manufacture of cement are other industries. There were in 1918 1,786 factories with \$244,697,000 capital, giving employment to 48,779 persons who received \$51,051,936.000 in wages and salaries. The value of materials used was \$103,936,000 and of goods produced \$207,678,000.

Shipbuilding was greatly stimulated by the World War. Owing to the shortage of shipping after its outbreak, a programme of building wooden ships was undertaken under the auspices of the Provincial Government. The Foundation Co. constructed a number of vessels for the French Government, and steel vessels for the Dominion Government were constructed at Victoria and Vancouver.

**Transport.**—The main line of the Canadian Pacific railway enters British Columbia through the Kicking Horse pass on its way to Vancouver. Another line of the same railway, entering the province by means of the Crow's Nest pass, serves the Kootenay country and joins the main line, by several water connexions, at Revelstoke. The Canadian National traverses the Yellowhead pass and proceeds through the northern part of the province to Prince Rupert near the Alaskan boundary. The Canadian National railways also run through the Yellowhead pass, turning S. to Kamloops, parallel to the Canadian Pacific, on the opposite side of the Fraser river, to Vancouver. From Victoria, the Esquimalt and Nanaimo railways run as far N. as Comox, and there is also a Canadian National line on the island. The Pacific Great Eastern, from N. Vancouver to Fort George, owned and to be operated by the Provincial Government, was under construction in 1921. Many portions of the province are tapped from the United States by branches of the Great Northern railway. The total mileage of railways in 1917 was 3,885.

The British Columbia Electric railway has radial lines extending from Vancouver to points in the Westminster district, and a suburban line from Victoria running through the Saanich district.

The Canadian Pacific railway operates a fleet of steamships which reach coastwise all points northward from Victoria and Vancouver to Prince Rupert and several ports in Alaska (including also ports on the coasts of Vancouver I. and the Queen Charlotte Is.) and S. to Seattle. There is also direct steamship connexion with San Francisco. The Canadian National, with a terminus at Prince Rupert,

makes regular connexions by fine twin-screw steamers with Vancouver and Victoria. The coastwise trade, especially in the summer, is enormous. The Canadian Pacific has also a splendid fleet of steamships plying to and from Japan and China, on the outward trip touching at the Philippine Is., and traffic arrangements with lines of steamers to and from Australia and New Zealand. There are numerous lines of steamships on the Pacific which make Victoria and Vancouver ports of call. The opening of the Panama Canal has proved of great advantage to the province. Steamers also ply on the navigable rivers and lakes in the interior of the country. (W. L. G.)

**BRITISH EAST AFRICA.**—The East Africa Protectorate, or "British East Africa," was in July 1920 annexed to the British Crown and renamed Kenya Colony (see KENYA).

**BRITISH EMPIRE** (see 4.666\*).—The white population of the British Empire in 1921 was (approximately) 60,693,000 (of whom about three-fourths lived in Great Britain and Ireland) Its brown or black population was (approximately) 360,670,000 (of whom British India, the Protected Indian States, Ceylon and the other Eastern colonies and dependencies contributed approximately 323,375,000, West Africa 20,151,000, East Africa 6,315,000, South Africa 5,801,000, British Central Africa 2,600,700, and the West Indies 1,490,000). The population of Tanganyika Territory (German East Africa) is estimated, in the British sphere of influence, at 3,500,000. The native population of German South-West Africa is small, owing mainly to the system of repression in force under German rule; the white inhabitants are between six and seven thousand. Forty-two per cent of the population of the German colonies in Africa were assigned under the Peace of Versailles to Great Britain, against 33% assigned to France and 25% assigned to Belgium. The total area of what was German New Guinea, along with the Bismarck Archipelago and the other islands attached to it, is about 90,000 sq. miles.

A remarkable development took place between 1910 and 1921, both in theory and in practice, in matters relating to the constitutional framework of the British Empire. It is true that at the Imperial Conference of 1911 a proposal, not thoroughly thought out, to set on foot an Imperial Council, of a somewhat nebulous character, received little support; and that, as long as Sir Wilfrid Laurier held the helm in Canada, closer co-operation among the members of the British Commonwealth of Nations was practically out of the question. But this same Conference witnessed a new departure which proved of singular good fortune for British interests. At a secret meeting of the Imperial Defence Committee Sir Edward Grey explained to the dominion prime ministers the hidden mysteries of European and world politics. Mr. Fisher was at the time the Labour Prime Minister of the Commonwealth of Australia, and the feelings of confidence and goodwill aroused by this spontaneous act on the part of the British Government bore abundant fruit when, after a brief interval, he returned to power in the autumn of 1914.

In other ways the proceedings of the 1911 Conference were of importance. Although the proposal of a permanent council or committee, to give continuity to the work of the Imperial Conferences, had come to nothing, mainly owing to the objections raised by Canada, still the establishment of a separate "Dominions Department" of the Colonial Office in London and the issue by it of annual reports were distinct steps in this direction. In any case, in going through the proceedings of the 1911 Conference, one notes a closer grip of existing facts than had been shown at previous conferences. Thus a satisfactory solution was arrived at of the problem of naturalization within the Empire, a solution which was afterwards embodied in Imperial legislation. Each dominion must continue to retain the power of regulating its own system of naturalization; but five years' residence in any portion of the Empire qualifies an applicant for the grant of imperial nationality, the decision of the question resting with that portion of the self-governing Empire in which such applicant has resided during the twelve months immediately preceding his application. A discussion of the subject of emigration brought out the great increase which had taken place in the most recent years in the number of British emigrants to the dominions, compared with the number of such emigrants to the United States,

The Conference, further, revealed the weakness of the existing system of political intercommunication. It was shown that the Declaration of London, which involved important questions of maritime law of vital interest to communities separated by thousands of miles of sea from Great Britain, had been approved without any consultation with or even notice given to the dominions. The excuse was that the dominions had not been parties to the Hague Conference; and that the Declaration of London had been the outcome of the proceedings of that body; but the British Government adopted a very apologetic tone and readily endorsed a resolution that, in future, the dominions should be given the opportunity of considering the matter before the signing of any convention which might affect their interests by the British delegates at the Hague Conference; and this same general rule should, as far as possible, hold good in the negotiation of other international agreements.

The anomalous character of the British Empire was well illustrated by the adoption of a resolution which was, indeed, the logical sequel of the action of Lord Salisbury in 1897 in connexion with the grant of a fiscal preference by Canada to British goods; but was none the less of a centrifugal character. It was agreed that in cases in which a British commercial treaty with a foreign Power bound the dominions, negotiations should be opened with the object of securing liberty to any of them to withdraw from the operation of such treaty, without impairing its validity with regard to the rest of the Empire. In some cases foreign Powers were unwilling to agree to such a proceeding; so that the only alternative was the denunciation by Great Britain of a treaty which otherwise it might be in her interest to retain.

Apart, however, from details, the Imperial Conference of 1911 did important work in cementing the intangible links connecting the different parts of the British Commonwealth. In the words of General Botha, it called into life "that friendship which must lead to coöperation, and better coöperation than we have had in the past."

Towards the end of 1911 Sir Wilfrid Laurier's long period of rule in Canada came to a close, the Liberal leader suffering defeat at the general election which took place over the question of trade reciprocity with the United States. In Ontario, whatever may have been the case elsewhere, the contest was fought as one connected with the maintenance of the British connexion; and the triumph of the Conservatives was hailed as a manifestation of imperial loyalty. The new Prime Minister, Sir Robert Borden, had for some years consistently maintained the view that, whilst a more generous contribution by Canada to the needs of the imperial navy was necessary, such contribution must involve a real partnership in the decision of those questions of foreign policy on which might depend the issues of peace or war. For the time being he was satisfied with the undertaking of the British Government that a Canadian representative would always be welcome at meetings of the Imperial Defence Committee, but it was obvious that this could not be the final solution of the problem. Sir Robert's attempt to give substantial help to the British navy by the gift of three battleships failed, it is true, through the action of the Canadian Senate in rejecting the measure; but the political claims which went along with the proposed gift were soon to find a partial fulfilment, the tremendous efforts put forth by the dominions in the World War forbidding, in any case, a simple return to the practice of the past.

On the purely naval and military side of the question, indeed, the results of the war might seem to vindicate the past policy. Dominion statesmen pointed with pride to the action of the little Australian navy, which, at the outbreak of war, promptly gave its services to the capture of the German colonies in the Pacific, whilst it was forthwith placed under the British Admiralty. The question of separate navies was for a long time a bone of contention between British naval experts and dominion public men, but it seems now impossible to contest the principle, though as late as 1918 the British Admiralty continued to advocate a single navy, under a single naval authority. In military matters the development of an imperial general staff and improvement

in military education had gone on, under the scheme initiated by Lord Haldane in 1909. Congenial ground was afforded for military reforms by the system of compulsory military training prevailing in Australia and New Zealand, a system which in the former country had been introduced by the Labour party. One may admit that the successes of the dominion troops in the war were mainly due to the individual initiative and valour of the rank-and-file and yet recognize the merits of the machinery through which these worked.

The independent character of the various portions of the Empire was well illustrated by the different attitudes they took up towards conscription, the Parliaments of New Zealand and of Canada, in spite of the hostility of the province of Quebec, having adopted it, whilst the people of Australia at two referenda refused its endorsement.

From the political standpoint, however, the situation was less satisfactory. The British Empire had gone to war in 1914 without the dominions having any voice in the decision. The circumstances, indeed, with regard to the violation of Belgian neutrality were so manifest as, in this particular case, to prevent the possibility of discussion; but, in the event of trouble in the future, the *casus belli* for the whole Empire may not always be so clear. It was obvious, then, that there was a real weakness in the system, requiring a practical remedy.

No Imperial Conference was held in 1915, owing to the exigencies of the war; and when it met in 1917, and again in 1918, it was accompanied by a new organ of government, of extreme significance. The Imperial War Cabinet was not, indeed, a Cabinet in the strict use of the word; because it had no direct executive authority, and because a majority at its sittings could not bind a dissentient minority; but, for practical purposes, it fulfilled the functions of a Cabinet, in concentrating upon a single objective the whole moral and material strength of the scattered Empire. It was hoped that an instrument which had proved so useful for the purposes of war might give the solution to the problem of the Empire in times of peace; such being the expectation of Mr. Lloyd George and of Sir Robert Borden. But a Cabinet of this kind requires a sacrifice of separate interests to the collective good such as is not often found except in times of emergency. Accordingly the meeting of Prime Ministers held in 1921, whatever may have been Lord Milner's intention when summoning it, bore at least in its initial stages little resemblance in its proceedings to a constitutional Cabinet, though in its final report it gave expression to the unanimous views of the Governments of the Empire.

At the opening meeting Mr. Lloyd George declared that, while in the past Downing Street controlled the Empire, to-day the Empire took charge of Downing Street. The main subject of discussion was the question of the renewal of the Anglo-Japanese Alliance. It was agreed by all parties that the alliance would require changes in its form, because of the changed conditions of the world, and in order that it should comply with the obligations imposed by membership in the League of Nations. But on the general question of the renewal of the treaty there was a difference of opinion. The Canadian Prime Minister, adopting the point of view of American public men and intent upon the promotion of the closest friendly relations between the British Empire and the United States, was opposed to the renewal of the treaty in any form. The Australian and New Zealand representatives, on the other hand, who had much to fear from the presence in the Pacific of an unfriendly or offended Japan, recognized in the renewal of the treaty the surest pledge for future peace. The friendship of Japan during the war had undoubtedly been of the greatest service to the British Empire; and the rôle of a Power, such as Great Britain, with over 300 million Asiatic subjects, might well be to act as a connecting link between the United States and Japan, playing to some extent the part played by France after the Anglo-French agreement of 1904 in establishing more friendly relations between Great Britain and Russia.

It fortunately proved unnecessary that the question should be decided forthwith; and in July the invitation of the United



States to the various Powers to attend a general conference later in the year on the subject of disarmament and the political questions connected therewith gave the opportunity for the whole question to be discussed from every point of view.

With regard to the question of naval defence the Conference resolved "that, while recognizing the necessity of coöperation . . . to provide such naval defence as may prove to be essential for security, and while holding that equality with the naval strength of any other Power is the minimum suggested for that purpose, this Conference is of opinion that the method and extent of such coöperation are matters for the final determination of the several Parliaments concerned, and that any recommendations thereon should be deferred until after the coming conference on disarmament."

It should further be noted that the dominion Prime Ministers attended the Cabinet Council at which the reply to the French note on Upper Silesia was considered. It had been intended to hold a special constitutional conference in 1922, but, having regard to the constitutional developments since 1917, the meeting saw no advantage in holding such a conference. They recognized, however, the necessity of continuous consultation, which could only be secured by an improvement in the communications between the different parts of the Empire.

Whether or not an Imperial Cabinet, on the model of the Imperial War Cabinet, be found to be practicable, it should be noted that a more elaborate method of solving the problem has been put forward. The "Round Table" movement took its rise from a small body of able and hard-working men who, having helped to bring about the union of South Africa, transferred their energies to the solution of the British imperial problem. A patient and detailed investigation of the whole subject was made by groups of inquirers, mainly belonging to the universities, throughout the Empire; and the results were recorded in carefully annotated volumes. The final outcome of the views of the majority—in most groups there was a dissentient minority—was the volume, *The Problem of the Commonwealth*, by Lionel Curtis, published in 1917. Though the book bound no one to the author's individual views, it is not likely ever to be superseded as a solution of the problem, from the point of view of an imperial federationist. Whilst the necessity of an Imperial Parliament and Executive was insisted upon, the necessity was also recognized of limiting, as far as was compatible with imperial safety, the functions of such Imperial Parliament and Executive. Dominion nationalism forbade that questions other than the management of foreign affairs, Imperial defence and finance in its relation with defence, along with the control of subject races, should be the province of the central authority. Thus the subject of the tariff was held to be outside its province.

Whatever its logical merits, the proposal failed to secure the support of public men and of the electors in the dominions; largely on the ground that the people of the dominions would never tolerate any form of taxation imposed by a Parliament not sitting within their own borders.

But, though imperial federation be in the existing state of public opinion an impossibility, it does not follow that a satisfactory scheme is not any nearer than it was before the war. The effects of the war seemed indeed in 1921 to be working in two directly opposite directions. On the one hand the war brought about a greater knowledge of Great Britain and its people among the many thousands of dominion soldiers who were in England when training or on leave, and had thus created bonds of mutual affection and sympathy. (The feeling embodied in the well-known warning, "No Englishman need apy," is now, we are told, in Canada a thing of the past.) Again, the visits of the Prince of Wales to the dominions in 1919-21 called forth an expression of loyalty and devotion to the monarchy, as embodying imperial unity, and to the individual Prince, as embodying in its most attractive shape at once the youth and the democratic spirit of these new nations, such as promised well for the permanence of the British connexion.

Upon the other hand, the war, with its consequences, was, as was inevitable, a forcing-house in the development of the

political status of the dominions, and hastened the putting forward of claims which might otherwise have lain dormant for many more years. During the peace negotiations dominion statesmen sat at the council table as representatives of their own communities, and not as mere assessors to the British representatives, their countries being recognized, for certain purposes, as separate states. At the signing of the Peace, King George, in each case, acted on the advice of the minister representing each individual dominion separately. Lastly, the dominions became full members of the League of Nations, undertaking, individually, the many serious obligations involved by such membership. These privileges, Sir Robert Borden has explained, were not obtained without struggle; but the opposition in no case came from the British Government.

Moreover, whilst the international position of the British Empire was thus being modified, General Smuts, the protagonist of the movement to reconcile complete local autonomy with the permanence of the Empire, was explaining the measures necessary to make theory to harmonize with practice. (It should be remembered that General Smuts was at the same time denouncing secession as at once a violation of the South African Constitution and a blow aimed at the British population.) No shred of authority, General Smuts insisted, must remain with the British Parliament or the Colonial Office. When dominion matters were in question the King must act exclusively on the advice of his dominion ministers, and, accordingly, the Governor-General must be appointed on their recommendation. Whence it follows that the only link left between Great Britain and the dominions is the personal link of the Crown, and that, logically, the dominions should have separate diplomatic representation in every capital. A beginning had been made in 1921 in the latter direction by the decision to appoint a Canadian minister at Washington, though it was doubtful how far such an appointment was really demanded by Canadian public opinion.

It is obvious how difficult under the new system might become the position of a constitutional monarch who found himself called upon to act in several different ways, on the advice of separate ministers, whose policies might be wholly discordant. When General Smuts first broached his views in 1917 he laid great store on the necessity for frequent meetings of the Prime Ministers of the British Commonwealth of Nations, with the object of insuring a common and collective policy; but latterly, under the stress of local conditions in South Africa, and perhaps under the influence of a natural impatience with the situation in Europe, this side of the shield seems to have been less before his attention.

At the Imperial Conference of 1917 it was agreed that the readjustment of the constitutional relations of the component parts of the Empire should form the subject of a special imperial conference, to be summoned as soon as possible after the cessation of hostilities; and it was settled provisionally that the conference should take place in 1922; but it seemed clear by 1921 that, in the reaction following upon the efforts of the war, any immediate attempt to draw closer the bonds of union would not meet with a favourable reception. To judge from the criticisms made on Lord Jellicoe's suggestions, the dominions were not yet prepared to contribute a fixed proportionate quota to the cost of the imperial navy. Underlying, however, this attitude of caution and distrust, there was still in reserve that spirit which made the Empire one in the supreme crisis of its history, the World War.

Other difficulties, besides the constitutional problem, beset the British Empire during the decade. Of these none caused greater anxiety than the treatment accorded to British Indians in the British dominions. With regard to immigration, it had become generally recognized in 1921 that each dominion had the right to make, and to enforce, such rules as it deemed necessary for its own individual interests. No sane Englishman would venture to quarrel with the policy of a white Australia, or with the consequences it may entail. Similarly, if the Union of South Africa, with its huge black population, refuses admission to British Indians, no complaint can be made. But it is a matter

of the utmost importance, in the interests of the Empire as a whole, that such Indians as have already found a home there should receive fair and generous treatment. The recognition of a modified form of self-government in India under the system known as "dyarchy" and the extension of representative institutions have greatly stimulated the political consciousness of the peoples of India; and things are now noted and resented which a few years earlier would have been treated as matters of course. The presence of Indian representatives at the Imperial Conferences of 1917 and 1918 served to bring home to the minds of dominion statesmen the new status obtained by India in the British Commonwealth of Nations, and the need for a new spirit in dealing with its population. Rules against Indian immigration could be reconciled with Indian dignity when reciprocal measures by India were formally sanctioned, and the hardships of existing laws with regard to the introduction of the wives of those already domiciled, or with regard to facilities for temporary or occasional visits, admit of easy mitigation. More difficult is the question of the franchise. In the past the argument has been that, as Indians had no voice in public affairs at home, they could not resent being treated in a similar way in a dominion. But now that they have begun their political apprenticeship in India itself the case is different; and, at the meeting of the Prime Ministers in 1921, the Indian representatives having laid great stress on the necessity of finding a remedy for this grievance, the conference, "in the interests of the solidarity of the British Commonwealth," recognized the desirability of granting citizenship to Indians lawfully domiciled in a dominion. It is significant, however, that the representatives of South Africa were unable to accept this resolution.

Nor is it in the dominions alone that this difficulty has been encountered. The Highlands of British East Africa (Kenya Colony) have developed into a white man's land, and Kenya is probably on its way to full responsible government. But Indians have for generations resorted to the shores of East Africa, and Indians have held that British East Africa's destiny lay in becoming a field for Indian immigration, under the British flag. The complete failure of such expectations, and the treatment accorded to British Indians in Kenya Colony by the British settlers, have doubtless been a contributory cause in promoting feelings of distrust and suspicion in India.

Under the Peace of Versailles a new form of colonial possession came into being. It seemed impossible, both in the interests of the natives and for military reasons, to restore to Germany the colonies that had been taken during the war. At the same time it did not appear seemly that a war, fought for moral ends, should be followed by a mere division of the spoil. The "mandatory" system was, therefore, evolved; the aim of which is to enforce the lesson that the possession of colonies, inhabited by savage or semi-civilized peoples, entails moral obligations toward such peoples. Accordingly their tutelage is entrusted to advanced nations who, by reason of their resources, their experience, or geographical position, can best undertake this responsibility, and who thus become mandataries on behalf of the League of Nations. The character of the mandate is differentiated according to the stage of development of the people, the geographical situation of the territory, its economic conditions, and other similar circumstances.

There are three kinds of mandates. Under the first (class A) the mandatory power stands in the position of administrative adviser and assistant until such time as the dependent community may be able to stand alone; its existence as an independent nation being provisionally recognized, subject to the execution by the mandatory of its trust.

In the case of the second form of mandate (class B) the population, as in German East Africa (assigned mainly to Great Britain), was still at the stage in which the mandatory must be exclusively responsible for the administration of the country; under conditions, however, which would guarantee freedom of conscience and religion (subject to the maintenance of public order and morals); the prohibition of abuses, such as the slave-trade, traffic in arms or in liquor; and would prevent the estab-

lishment of fortifications or military and naval bases, and the military training of the natives for other than police purposes and actual defence. In territories under this form of mandate equal opportunities must be given for the trade and commerce of all nations belonging to the League of Nations.

Lastly (class C) there were territories, such as German South-West Africa and certain of the islands in the Pacific south of the Equator (assigned to the Union of South Africa and to Australia and New Zealand), which, owing to the sparseness of their population, their small size, or their remoteness from the centres of civilization, or their geographical contiguity to the territory of the mandatory Power, could be administered most conveniently under the laws of the mandatory as integral portions of its territory; but subject to the safeguards above mentioned in the interests of the indigenous population.

The recognition of this last class was, in great measure, due to the exigencies of the British dominions. The Union of South Africa, Australia and New Zealand were all countries having a protective tariff. Had their new possessions come under the provision applying to class B, they must either have set on foot different tariff arrangements in their possessions or else have incurred the obligation to throw open their commerce to all members of the League.

That the League of Nations intended to take very seriously its work under the mandatory system was shown by the amendments proposed by the sub-committee of the executive committee which dealt with the British draft of the mandate for Tanganyika. Amongst other alterations of a stringent character it was proposed that, on the coming into force of the mandate, "all lands not already alienated by regular title, whether occupied or unoccupied," should be declared "native lands," and that no native lands should be alienable, a provision which would apparently render impossible any kind of European colonization or development. The further proposal that any person in the territory should be able, through the medium of the mandatory Power, to bring complaints to the League with regard to the non-observance of the terms of the mandate might, conceivably, lend itself to abuse, in the event of such complaints being manufactured or encouraged for political purposes.

With regard to trade relations, there was no movement during 1920-21 in the direction of an imperial Zollverein. In Canada the party that in opposition had denounced protection had found insuperable difficulties in the way of changing the policy of their predecessors and contented themselves with maintaining the British preference. But the effect of reciprocity with the United States, had it come into force, must have been to diminish the advantage to British trade of such preference. In these years, whilst the policy of preference for British goods gained in favour throughout the dominions, it was seldom advocated unless it could be accompanied by a general raising of the scale of the general tariff. In Great Britain the Unionist leaders had found themselves faced with the difficulty of proposing duties upon primary articles of food; and the revised platform merely demanded a preferential treatment of goods produced in the Empire which were already subject to duties, a modest proposal which was carried into effect by the budget of 1920.

At the 1911 Conference Sir W. Laurier, tired of general discussions in which neither party was able to convince the other, made the practical proposal that a peripatetic Royal Commission should be set on foot, to take stock of the existing resources of the Empire, and to consider how trade might be increased between its component parts. This commission did much useful work in the years before the war; and the appointment of new trade commissions in the different dominions and colonies had the effect of stimulating trade with Great Britain. Unfortunately, in the special circumstances which were the aftermath of the war, there were more formidable obstacles in the way of the expansion of British trade than ignorance or indifference on the part of possible customers.

In another direction the war has had regrettable results. Nothing can help so much to promote imperial unity as a cheap postage system, both for letters and for newspapers, and cheap

facilities for travel. But the taxation necessitated by the cost of the war, and the increase in prices generally, gave a rude setback in these directions. Conquests of the air may eventually help to solve the problems of time and space—the Prime Minister at the Conference of 1921 decided upon an extension of wireless telegraphy and on the retention of existing material useful for the development of imperial air communications, but in 1921 the condition of things prevailing had been made less favourable to habits of intercourse between the members of the scattered Empire than it was at the beginning of 1914.

As regards the Crown colonies, the period, until the changes brought about by the war dealt with above, was one concerned with the development of the existing possessions rather than with the acquisition of new ones. Great attention was paid to the solution of the problems connected with the natives, with, on the whole, satisfactory results; e.g. the recognition by cotton experts that cotton-growing in the Empire can be more successfully carried on under a system of cultivation by small native proprietors than under the system of large plantations owned by Europeans, with its attendant moral dangers, has gone some way to remove the standing crux of colonial administration—how to combine the due development of the material resources of these countries with the necessary safeguarding of the moral interests of the native populations. Similarly, the treatment of the land question has shown more and more respect for native customs and ideas. The amalgamation of Northern and Southern Nigeria in 1914 enabled the development of the largest British Crown colony or protectorate to be carried on with greater speed and efficiency. In Northern Nigeria, as in the Federated Malay States, a system is at work which, when conditions are favourable, gives admirable results. The native chiefs govern their subjects without the existence of direct communication between the British officials and the people. The difficulty in the way of the employment of this system more generally is that it requires both strong and upright native rulers and British residents of no little tact as well as ability. Whatever be the system of government, it is clear that the interests of a numerous native population must not be abandoned to the will of a small minority of educated and Europeanized natives, who are wholly akin to their countrymen in aims and ideals, any more than they should be the victims of the needs of the few European settlers. The establishment in Nigeria, side by side with an extended executive council, of a new council, including amongst its members the leading official and unofficial representatives both of the European and of the native community, enables the Government to keep in touch with such public opinion as can find expression. A council of this kind may play a useful part, although it has no direct executive or legislative powers. During the war the striking loyalty of the Mohammedan states in Northern Nigeria and the attitude of the natives throughout the British colonies bore witness to the soundness of the principles upon which the British native policy has been built. There are, no doubt, serious difficulties in the way. The effects in the more civilized communities of a superficial and ill-assimilated education tend to increase indiscipline and vanity amongst the young; whilst the gradual weakening of the tribal system, and of the authority belonging to the chiefs, is fraught with danger. But the experience of British East Africa has shown that, in a country where the disintegrating forces are exceptionally strong, something may be done by skilful administration to revive the tribal authority and to resuscitate the native tribunals. Everywhere it has been made clear that no form of compulsory labour on behalf of private employers can be tolerated. The question of taxation, with the view of developing the natives' inclination to work, has given rise to difficulties. Attention may be called to the system prevailing in Papua, under the Australian Commonwealth Government, where the proceeds of such taxation are strictly earmarked for purposes connected with the interests of the aborigines.

A marked feature of the period has been the extension of railways which followed upon the financial success of the so-called Uganda railway. In East Africa there has been established a network of railways, steamers and roads, extending into the

heart of the Uganda protectorate, and tapping a vast area of country; whilst in West Africa the progress has been no less noticeable.

In the Far East the addition, in the beginning of 1914, of Johor to the number of the Federated Malay States was an event of importance, the undeveloped resources of the country being great. In no quarter of the world has the British system of government met with more success than in the Malay Peninsula. The wonderful wealth of the country has, no doubt, made things easier—nowhere else could a first-rate railway system have been built entirely out of revenue; and the establishment of the plantation rubber industry upon a large scale, before its introduction into other countries, enabled the pioneers to reap the benefits of high prices. Nor was the British Government unmindful of the interests of the natives, special legislation being passed to prevent them from yielding to their natural inclination to alienate their ancestral holdings to European capitalists. The spontaneous gift of the battleship "Malaya" to the British navy by the Federated Malay States in 1912 attested the popularity of the British rule; and even more striking were the expressions of loyalty from the Asiatic population at the outbreak of war, followed by a voluntary annual contribution towards its expenses which had the warm support of the unofficial members of the Council. An economic reaction inevitably occurred after the fictitious prosperity caused by the high prices that prevailed during the war, but such depression was in no way connected with the system of government.

In the West Indies the years 1910-21 saw few changes of importance. Criticism of existing political conditions had come more to the surface, and proposals were more often heard for the establishment of a federal system of government. In Jamaica the attempt is being made to interest the unofficial members of the Legislative Council more closely in the work of the Government. With regard to federation, the difficulties in its way, in the case of islands separated from each other by hundreds of miles of sea and possessing different forms of government and different ideals and prejudices, remain as great as ever; but the work of the imperial department of agriculture for the West Indies has tended to promote economic development generally; and the agreement, setting on foot a system of reciprocal trade preference, made between Canada and the West Indies in 1917 should be of benefit to the latter.

Parliamentary papers, the Annual Reports from the Crown Colonies and Dominions, Hansards, together with A. B. Keith, *Imperial Unity and the Dominions* (1916), are the best authorities for the last 11 years of the British Empire. With regard to the future form of its constitution R. Jebb, *The Briannic Question* (1913), L. Curtis, *The Problem of the Commonwealth* (1917), and H. Duncan Hall, *The British Commonwealth of Nations* (1920) represent different points of view. (H. E. E.)

**BROADBENT, SIR WILLIAM HENRY, 1ST BART.** (1835-1907), English physician, was born at Lindley, Yorks., Jan. 23 1835, the son of a woollen manufacturer. Educated at Huddersfield, he afterwards studied medicine at Owens College and the Royal School of Medicine, Manchester, and at Paris. From 1859 to 1896 he was physician to St. Mary's hospital, London, and from 1860 to 1879 physician to the London Fever hospital. In 1893 he was created a baronet, and in 1898 became physician extraordinary to Queen Victoria, an office in which he was continued by King Edward VII. Broadbent was an authority on heart affections, and also carried out much research on tuberculosis. His chief works are *The Pulses* (1890), and *The Heart* (1897). He died in London July 10 1907, and was succeeded in the baronetcy by his son, now Sir John Broadbent, Bart. (b. 1865), also a distinguished physician.

**BROADHURST, HENRY** (1840-1911), English Labour leader and Liberal politician, was born at Littlemore, near Oxford, April 13 1840, the son of a stonemason. He was educated at the village school, and at the age of 13 was apprenticed to his father's trade. He worked at it for nearly twenty years, going to London finally in 1865, where he was employed in the erecting of the House of Commons. In 1873 he was elected chairman of the masons' committee during a strike, and from

that time was prominent as a trade union official. In 1875 he was elected secretary of the parliamentary committee of the trade union congress. He entered Parliament in 1880 as Liberal member for Stoke-on-Trent. In 1885 he was elected for the Bordesley division of Birmingham, and in Feb. 1886 was appointed under-secretary to the Home Office, going out with the Gladstone Government later in the year. He belonged to the older school of trade unionism and was opposed to such demands as an 8-hour day fixed by law. His moderate policy was defeated at the trade union congress of 1890, and he then resigned his secretaryship. Both in 1892 and 1893 he was unsuccessful in his parliamentary candidatures. In 1892 he was appointed a member of the royal commission on Labour, and in 1894 he was elected Liberal member for Leicester, which seat he held until 1906, when he retired on account of ill health. He died at Cromer Oct. 11 1911. He published the story of his life in 1901, and a book on *Leasehold Emancipation* in conjunction with Lord Loreburn in 1885.

**BROCK, SIR THOMAS** (1847— ), English sculptor (see 4.623), was in 1911 created K.C.B.

**BROCKDORFF-RANTZAU, COUNT ULRICH VON** (1869— ), German diplomatist, was born May 29 1869 at Schleswig. After having held various diplomatic positions at St. Petersburg, Vienna and Budapest he was appointed German minister at Copenhagen, a post which he held from 1912 to 1918. He was very active in the Danish capital during the World War in collecting news and keeping in touch with the various international agencies which were interested in paving the way for peace or endeavouring to undermine the war spirit of the Western Powers. On Dec. 20 1918 he was appointed Secretary of State for Foreign Affairs and in March 1919 went to Versailles as chief of the German delegation for the peace negotiations. He resigned on June 20 in consequence of his unwillingness to advise the German Government to accept the terms of the Treaty of Versailles.

**BROOKE, SIR CHARLES JOHNSON** (1829-1917), 2nd Raja of Sarawak (see 24.208), died at Cirencester May 15 1917. He was succeeded by his eldest son, Charles Vyner Brooke (b. 1874).

**BROOKE, RUFERT** (1887-1915), English poet, was born at Rugby Aug. 3 1887, and educated at Rugby and King's College, Cambridge, where he afterwards won a fellowship. In 1911 he issued his first volume of *Poems*. In 1913 he undertook a journey through America and on to Samoa, sending home vivid letters, which recall those of R. L. Stevenson, to a London evening paper; they were published after his death in volume form as *Letters from America* (1916) with a prefatory appreciation by Henry James. These two books and a second and posthumous volume of poetry *1914 and other Poems*, with an essay on *John Webster and the Elizabethan Drama* (1916), make up his literary output; but its quality and high promise render the greater the loss to English literature by his premature death on active service. He had joined the Naval Brigade very early in the World War, took part in the ill-fated effort to relieve Antwerp, spent the winter in an English camp and went out to Gallipoli in the spring, but on the way there fell ill of blood-poisoning and died at sea in a French hospital ship April 23 1915. He was buried on the island of Lemnos. His *Collected Poems*, with a prefatory memoir by Edward Marsh, were published in 1918.

**BROOKE, STOPFORD AUGUSTUS** (1832-1916), English divine and man of letters (see 4.645), died at Ewhurst, Sur., March 18 1916.

See L. P. Jacks, *Life and Letters of Stopford Brooke* (1917).

**BROOKFIELD, CHARLES HALLAM ELTON** (1857-1913), English actor and playwright, was born in London May 19 1857, and educated at Westminster and Trinity College, Cambridge. He studied law for a time at the Inner Temple, though he was never called to the bar, and he was for several years on the staff of the *Saturday Review*. In 1879 he took to the stage, appearing first in *Still Waters Run Deep* and becoming a member of the Bancrofts' company at the Haymarket theatre,

London, from 1880 to 1885. Later he played there with Herbert Tree in *Jim the Penman*, *The Red Lamp* and other melodramas, as well as in Oscar Wilde's *An Ideal Husband*. But it was rather as a wit and a writer that his reputation was gained, his stories and *mois* becoming famous. He wrote alone, or in collaboration, a number of lively plays, of which the best known was *Dear Old Charlie*, and he published his *Random Reminiscences* (1902). He also collaborated with his wife, Frances Mary Brookfield, in an account of his parents *Mrs. Brookfield and her Circle* (1905). Frances M. Brookfield was also the author of *The Cambridge Apostles* (1906) and of some notable novels, especially *My Lord of Essex* (1907) and *A Friar Observant* (1909). In 1911 Brookfield was appointed joint-examiner (censor) of plays under the Lord Chamberlain—an appointment which had an element of humour in view of the character of some of his own plays. He died in London Oct. 20 1913.

**BROUGH, FANNY WHITEHEAD** (1854-1914), English actress, who came of a well-known family of actors, was born in Paris July 8 1854. She first appeared on the stage at Manchester in 1869 in a pantomime written by her uncle, William Brough. In 1870 she appeared in London with Mrs. John Wood at the 'St. James's' theatre. She played in *Money* with the Bancrofts in 1872, in *The Wife's Secret* and *The Ironmaster* with the Kendals in 1888, and in *The Man from Blankley's* with Charles Hawtreay in 1901 and again in the United States in 1903. She died in London Nov. 30 1914.

**BROUGHTON, RHODA** (1840-1920), English novelist, was born in N. Wales Nov. 29 1840, the daughter of a clergyman, who was squire as well as rector of Broughton, Staffs. She produced her first novel, *Comeh up as a Flower*, in 1867, following it at brief intervals by *Not Wisely but too Well* and *Red as a Rose is She*. In the English county society, in which she had been brought up, such novels were then regarded as too daring experiments, to be kept as far as possible out of the hands of the young. But this *succès de scandale* was short-lived and, as mid-Victorianism began to fade, Miss Broughton's reputation as a shocker of convention soon gave place to a more sober recognition of her merit as a story-teller. "I began life as Zola," she said of herself, "I finish it as Miss Yonge." In the interval she had spent 20 years in Oxford, where she was a distinguished social figure, and the last 30 years at Richmond as a semi-invalid, and she had published some 20 novels, the latest, *A Poet in her Folly*, appearing after her death, with a prefatory appreciation by Marie Belloc-Lowndes. She died at Headington near Oxford, June 5 1920.

**BROWN, FRANCIS** (1849-1916), American Semitic scholar (see 4.658), died in New York Oct. 15 1916. He had been president of Union Theological Seminary, New York, since 1908. In 1911 he was tried for heresy before the Presbyterian General Board on the ground that he had published statements "contrary to cherished Presbyterian and evangelical doctrines," but was exonerated.

**BROWN, JOHN GEORGE** (1831-1913), American painter (see 4.661), died in New York City Feb. 8 1913.

**BROWN, PETER HUME** (1850-1918), Scottish historian, was born in Haddingtonshire Dec. 17 1850, and educated at Edinburgh University, where he afterwards became professor of ancient history. In 1908 he was appointed Historiographer Royal for Scotland, and from 1913 to 1914 Ford lecturer at Oxford. Besides his various histories, he is the author of a *Life of John Knox* (1895) and is mentioned as an authority in the bibliography of John Knox (see 15.882). He died at Edinburgh Nov. 30 1918; his unfinished *Life of Goethe* was completed by Lord Haldane and published in 1920.

**BROWNE, SIR BENJAMIN CHAPMAN** (1839-1917), British engineer, was born at Stout's Hill, Glos., Aug. 26 1839 and was apprenticed to the Elswick works near Newcastle-on-Tyne. He became an expert on harbour work and carried out harbour works at Tynemouth, Falmouth and in the Isle of Wight. In 1870 he took over the locomotive works of R. & W. Hawthorn at Forth Banks, in 1886 combined these with those of Andrew Leslie & Co., and until 1916 was chairman of

the combination. He was knighted in 1887. He died at Westacre, Newcastle-on-Tyne, March 1 1917.

**BROWNING, JOHN M.** (1854- ), American inventor, was born at Ogden, Utah, in 1854, of Mormon parentage. His father was a gunsmith. The son, from childhood, displayed remarkable talent for invention. In 1879 he secured his first patent for a breech-loading single-shot rifle. He made 600 of these guns in his Ogden shop before selling the patent to the Remington Company. He designed many types of sporting firearms such as the Remington autoloading shotguns and rifles; the Winchester repeating shotguns, single-shot and repeating rifles; the Stevens rifles; and the Colt automatic pistols. From all these he drew large royalties. In 1890 a machine-gun of his design, but known as the Colt, was adopted by the U.S. army. He always avoided publicity and in no case required that his invention bear his name. In one establishment alone was his name used, the Fabrique Nationale at Liège, Belgium, which fell into the hands of the Germans at the beginning of the World War, in 1914. Browning had shortly before been made a chevalier de l'Ordre de Léopold and decorated by King Albert, on the occasion of the completion of the millionth Browning automatic pistol at Liège. He later developed two types of machine-gun which were adopted by the United States in 1918 for use in the World War. One of these guns on test fired 39,000 rounds before breakage developed. In lieu of royalties, which would have amounted to some \$10,000,000, he accepted from the U.S. Government a lump sum of \$1,500,000.

**BRUCE, SIR DAVID** (1855- ), British bacteriologist, was born at Melbourne May 29 1855. He was educated at Stirling high school and Edinburgh University, where he took his degree of M.B. in 1881. He entered the R.A.M.C. in 1883, and from 1884 to 1889 served in Malta and Egypt. His stay in Malta was marked by his researches into the origin of Malta fever, and in 1887 he discovered the micro-organism of this disease, propounding the theory that it was spread by the use of goats' milk (see 17,514). In 1889 he became assistant professor of pathology at Netley, and in 1894 went to South Africa, where he remained until 1901, serving throughout the South African War. In 1902 he became a member of the Army Advisory Board, a post which he retained until 1910. For many years Bruce conducted researches into the origin of sleeping-sickness, and in 1894 he discovered the micro-organism not only of that disease but also of nagana (tsetse fly disease), and the method of their dissemination. In 1903 he went to Uganda as director of the Royal Society's commission for the investigation of sleeping-sickness, and in 1904 proceeded to Malta to carry on further investigations into Malta fever, returning to Uganda in 1908. In every case a great advance in the study of tropical medicine was the result. From 1911 to 1914 he was in Nyasaland, investigating the possible connexion between human and cattle diseases, and in 1914 became commandant of the Royal Army Medical College, holding the post till 1918. Bruce, who was knighted in 1908, was created K.C.B. in 1918 and retired in 1919. He published many papers on tropical diseases.

**BRUCE, SIR GAINSFORD** (1834-1912), English judge, was born in 1834. He graduated at Glasgow University and was called to the bar in 1859. He joined the northern and afterwards the north-eastern circuit, and during 1869-1882 reported Admiralty and ecclesiastical cases for the *Law Reports*. His strength lay in Admiralty law, and he made several contributions to its literature, notably an edition of Williams and Bruce's *Admiralty Practice*, and the 4th edition of *Maunder and Pollock on Shipping*. He was recorder of Bradford during 1877-92, and successively solicitor-general (1879) and attorney-general (1886) to the county palatine of Durham. A Conservative in politics, he represented Holborn in Parliament from 1888 till he was raised to the bench in 1898. He was made a privy councillor on his retirement in 1904. He died at Bromley, Kent, Feb. 24 1912.

**BRUGES, Belgium** (see 4,678).—Pop. 53,595 in 1914. In 1914, 685 vessels of 316,000 tons entered the port, and just prior to the World War the improvement of transport between the town and Zeebrugge promised to restore its former prosperity.

The Hôtel de Louis de Gruuthuse (who was given the title of Count of Winchester by Edward IV.) was converted into a museum of antiquities about 1890.

Up to Oct. 10 1914, Bruges was the headquarters of the British force that was first sent to Belgium after the outbreak of the World War. The town remained some 20 m. behind the German front at Dixmude and was at first of little military importance, but with the growth of submarine warfare and the abandonment of Ostend as a naval base, it became important as a place for the assembling of parts of submarines brought overland from Germany. Capt. Fryatt, of the steam packet "Brussels," was shot in the cavalry barracks of the rue Longue on July 27 1916. The town remained in the hands of the Germans until Oct. 19 1918.

**BRUNNER, HENRY** (1840-1915), German historian (see 4,685), published in 1909 *Geschichte der englischen Rechtsquellen im Grundriss*. In 1913 he issued a sixth edition of *Grundzüge der deutschen Rechtsgeschichte*. He died in 1915.

**BRUNNER, SIR JOHN TOMLINSON, 1ST BART.** (1842-1910), British chemist, was born at Everton near Liverpool Feb. 8 1842, the son of a schoolmaster of Swiss nationality. Educated in his father's school he entered a Liverpool merchant's office in 1857; and in 1873 established, with the distinguished chemist Ludwig Mond (see 18,693), the alkali works at Northwich which became the largest in the world. He was a member of several royal commissions, represented Northwich in Parliament during 1885-6 and again from 1887 to 1909, was created a baronet in 1895 and a privy councillor in 1906. His public benefactions, especially to Northwich and Runcorn, were numerous, and he also gave largely to Liverpool University. He died at Chertsey July 1 1910.

**BRUNTON, SIR THOMAS LAUDER, BART.** (1844-1916), British physician, was born at Hiltons Hill, Roxburgh, March 14 1844. He was educated at Edinburgh, where he graduated M.B. in 1866 and M.D. in 1868, also studying for short periods at Leipzig, Berlin, Vienna and Paris. In 1870 he was appointed assistant physician to St. Bartholomew's hospital, with which he was connected for the rest of his life, both as physician and lecturer. One of his most noteworthy discoveries was the introduction of nitrate of amyl for the relief of angina pectoris (1867). In 1886 he was a member of the commission which investigated the Pasteur discovery, and in 1889 went to Hyderabad on the invitation of the Nizam to conduct experiments on the results of the administration of chloroform. He was knighted in 1900 and created a baronet in 1908. Lauder Brunton published various valuable works, including *A Text-Book of Pharmacology, Materia Medica and Therapeutics* (1892); *Lectures on the Action of Medicines* (1897) and *Therapeutics of the Circulation* (1908). He died in London Sep. 16 1916.

**BRUSSELS, Belgium** (see 4,692).—The pop. of the city proper in 1920 was 156,924, showing a decrease since 1910 of 39,645, due to the expropriation and demolition of houses for public improvements. The total pop. of Greater Brussels (comprising ten suburbs and including the recently annexed suburb of Laeken) was 831,396 on Jan. 1 1920. The most populous suburbs at the same date were Schaarbeek 108,590, Ixelles 91,956, Molenbeek, 77,708, St. Gilles 69,716, Laeken 43,729, Forest 32,926.

The various areas composing the city having certain interests in common, notably the maintenance of police and charitable services, a *Conférence des bourgmestres*, on which 15 communes were represented, was instituted in 1909, but subsequently the unification of areas was resisted by the greater number of the larger communes. A law of April 2 1921, however, initiated by the burgo-master, Adolphe Max, decreed the annexation to Brussels proper of the communes of Laeken, Haeren, and Neder Overheembeek, as well as part of Molenbeek, and a small part of Schaarbeek, in order to facilitate the construction of the proposed new outer port which the authorities wished to bring entirely within area of the city proper. As a result, the area of the city proper has more than tripled; it covers 3,286 hectares 94 ares instead of 1,071 hectares 95 ares, and includes an additional pop. of about 54,000.

During 1910-21 Brussels underwent considerable transformation. The old harbour basins were filled in in 1910; the Isabella quarter of the city, situated between the rue Royale and the Place Royale,

as well as the Putterie quarter near the university, were demolished in order to make room for a new central station, which project, however, seemed in 1920 unlikely to materialize, the Nord-Midi junction being abandoned. Numerous banks were established in the upper town—in the rue Royale and Place Royale. In the Schaerboek area, new arterial roads were made and the Parc Joseph was endowed with a fine sports ground. The palace of the Count of Flanders became the Banque de Bruxelles, and, in Nov. 1918, the city acquired the palace of the Duc d'Arburg, and gave it again its old name of Palais d'Egmont.

The harbour works—planned in 1896 for making Brussels an inland seaport, including the widening of the canal and the construction of three large basins, the largest of which, the Vergote basin, has 20,000 metres of quays—were completed in 1908. These being found inadequate, the construction of a vast outer port in the plain between Laeken and Vilrode was begun. As an outcome of this undertaking, Laeken was brought within the city area.

The German occupation of the capital during the World War extended from Aug. 1914 to Nov. 1918. General Sixt von Armin's troops entered on Aug. 20, and on Sept. 2 Field-Marshal von der Goltz was appointed governor-general of Belgium, but was succeeded by General von Bissing in 1915. Numerous social relief movements were instituted outside of German intervention; among them the *Comité National de Secours* had its headquarters at Brussels, and with the aid of Mr. Hoover's American committee organized the feeding of the Belgian population. On the suppression of Allied newspapers, a patriotic journal, *La Libre Belgique*, was secretly printed in Brussels and widely circulated during the war, the Germans being unable to discover the press from which it issued. Among the many infamous executions, that of Philippe Baucq and of Nurse Edith Cavell stand out. A revolt of German soldiers against their officers broke out on Nov. 10 1918, and a violent conflict occurred in the Place Roger opposite the Gare du Nord. The Belgian army reoccupied Brussels on Nov. 18 1918, and the King and Queen reentered the city in state on Nov. 22.

**BRUSSILOV, ALEXEI** (1856— ), Russian general, was born in 1856. His military career began in the Caucasus. His courage and capacities brought him to notice in the war with Turkey in 1877-8. The greater part of his military life was passed at the cavalry school for officers in St. Petersburg, of which he became director in 1900. Well acquainted with cavalry technique, of great erudition, he was very useful in this capacity. In 1905 General Brussilov commanded the second guard cavalry division, in 1909 an army corps, and somewhat later he was assistant to the commander-in-chief of the Warsaw military district. At the beginning of the World War he was nominated commander of the Russian VIII. Army, which acted with brilliant success in Galicia in 1914 and 1915. General Brussilov's reputation grew steadily, and in the winter of 1915-6 he was called to the command of the armies of the south-western front. During the summer of this year he conducted the great offensive in Galicia, which resulted in the capture of over 450,000 prisoners, with enormous booty and trophies, and the relief of the Italian army by the withdrawal of considerable enemy forces thence to meet the crisis of Lutsk. In May 1917 after the revolution he was appointed to the supreme command, but he did not hold the appointment long. Later, he accepted the Bolshevik régime, and was often, though erroneously, reported to be in supreme command of the Bolshevik armies during the wars of 1919-20.

**BRYAN, WILLIAM JENNINGS** (1860— ), American political leader (see 4.697), announced that he was not a candidate for the Democratic presidential nomination in 1912, but he attended the Democratic convention, and it was largely owing to his personal influence and his large popular following that the nomination went to Woodrow Wilson. In 1913 he was appointed by President Wilson Secretary of State, and from the start devoted much attention to the negotiation of peace treaties with foreign countries. He declared that America should wage no war while he was Secretary. Soon after entering office he went to California and urged, unsuccessfully, that the state Legislature and the governor delay action on the proposed Webb anti-alien land ownership bill, so displeasing to the Japanese Government. In 1914 he supported the repeal of the

Panama Canal tolls bill, which excluded American coastwise shipping from the payment of fees. After the outbreak of the World War he was deeply interested in attempts to restore peace. His attitude toward foreign war loans was clearly expressed in an announcement from the Department of State (Aug. 15 1914), that "There is no reason why loans should not be made to the governments of neutral nations, but in the judgment of this Government loans by American bankers to any foreign nation which is at war is inconsistent with the true spirit of neutrality." When, however, in Dec. of the same year, Senator Hitchcock introduced a bill to lay an embargo on the shipment of arms, the Secretary informed the British ambassador that it had not been introduced "at the suggestion of the administration"; and later, in 1915, in a letter "to the German Americans" he declared that it would have been in violation of the laws of neutrality to change international rules during war by forbidding the exportation of arms. After the sinking of the "Lusitania," in 1915, he signed the first strong note of protest to Germany. Upon the receipt of the German reply, and while the second note was being prepared, Dr. Dumba, the ambassador of Austria-Hungary, called at the Department of State and asked Secretary Bryan why the United States dealt more harshly with Germany than with Great Britain. The Secretary replied that Great Britain had only interfered with the commerce of the United States while Germany had drowned its citizens. This plain statement was ignorantly or wantonly misinterpreted by some German official, and the report was widely spread that Mr. Bryan had said that the note was for "home consumption," and not to be taken too seriously. There was, however, absolutely no truth in this report, even Dr. Dumba denying it in a dispatch to his Government. When the President wrote his second "Lusitania" note, Secretary Bryan resigned, June 8 1915, saying in his letter of resignation: "You have prepared for transmission to the German Government a note in which I cannot join without violating what I deem to be an obligation to my country."

During his term of office he had negotiated 30 treaties with foreign nations, requiring the submission of disputes to impartial inquiry and a delay of a full year for arbitration before going to war. Such a treaty had not been concluded with Germany, but was under consideration when interrupted by the World War. As Secretary he was often criticised because of numerous paid engagements on the lecture platform, undertaken, he said, to supplement his inadequate salary; but it was never shown that he was less attentive to the demands of his office than any predecessor. He continued, after his resignation, to work in the interests of peace; opposed the Anglo-French war loan; attacked the Navy League and the National Security League; and tried to resist the growing demand for preparedness in America. In 1916 he was defeated in Nebraska as candidate for delegate-at-large to the Democratic National Convention. He went, however, as a reporter and gave full support for the renomination and later the reelection of President Wilson. From the announcement by Germany of the resumption of submarine warfare to the actual declaration of war, he favoured any measure that would keep America out of war no matter how largely it involved the surrender of American rights on the sea. But when war was declared he asked to be enrolled as a private, though then 57 years of age; urged loyal support of the President's war measures; and in his own paper, *The Commoner*, strongly condemned obstruction of the selective draft as well as abuse of liberty of speech. He supported the League of Nations but thought that the Monroe Doctrine should be specifically recognised. He desired a constitutional amendment changing the two-thirds vote required in the Senate for making a treaty, so that the country could get out of war as easily as it got in. In 1920 he attended as a reporter for his paper both the Republican and the Democratic National Conventions and worked in vain for a dry plank in their platforms. The same year he was tendered the presidential nomination of the Prohibition party but declined. He was disappointed with the nomination of James M. Cox as Democratic candidate, but



declared that he would not leave the party. For the most important "progressive" measures adopted by the United States in recent years, the popular election of senators, an income tax, the requirement of publication of ownership and circulation by newspapers, the creation of a Department of Labor, national prohibition and woman suffrage, Bryan laboured earnestly, and their adoption was due in part at least to his popular persistent appeal.

**BRYANT, SOPHIE** (1850- ), British educationist, was born in Dublin Feb. 15 1850, the daughter of the Rev. W. A. Willock. She was educated privately, but later gained a scholarship to Bedford College, London, where she graduated with honours in mathematics and moral science (1881). At the age of 19 she married Dr. William Hicks Bryant, of Plymouth, but on his death a year later resumed her work, and in 1884 took the degree of D.Sc. in moral science, being the first woman to take that degree. In 1875 she became mathematical mistress at the North London Collegiate school for girls, and in 1895 succeeded Miss Buss as its headmistress. Dr. Bryant served on the royal commission on secondary education (1894), and was a member of various educational committees. She retired from her post at the North London Collegiate school in 1918.

She published, besides many articles on scientific and educational subjects, *Educational Ends* (1887); *The Teaching of Morality in the Family and the School* (1897) and *How to Read the Bible in the Twentieth Century* (1918); besides *Celtic Ireland* (1889), and *The Genius of the Gael* (1913).

**BRYCE, JAMES BRYCE, 1ST VISCOUNT** (1838- ), British jurist, historian, politician and diplomatist (see 4.699), remained in the United States as British ambassador till 1913, a period of six years. The appointment, criticised at the time as withdrawing from the regular diplomatic corps one of its most coveted posts, proved a great success. The United States had been in the habit of sending, as minister or ambassador to the Court of St. James's, one of its leading citizens—a statesman, a man of letters, or a lawyer—whose name and reputation were already well known in Great Britain. For the first time Great Britain responded in kind. Mr. Bryce, already favourably regarded in America as the author of a classical work on the American Commonwealth, made himself thoroughly at home in the country; and, after the fashion of American ministers or ambassadors in England, he took up with eagerness and success the rôle of public orator on matters outside party politics, so far as his diplomatic duties permitted. These duties he performed to the satisfaction of his own Government and the Government to which he was accredited. The difficulty between America and Newfoundland about fisheries was referred to the Hague Tribunal for final settlement. Most of the questions with which he had to deal related to the relations between the United States and Canada, and in this connexion he paid several visits to Canada to confer with the governor-general and his ministers. He was criticised, both in England and in Canada, for forwarding, in 1911, in the course of his duties as ambassador, an arrangement for reciprocity between the two North American states; but the general election, which substituted Sir R. Borden as Prime Minister of Canada for Sir W. Laurier, put an end to the negotiations. At the close of his embassy he told the Canadians that probably three-fourths of the business of the British embassy at Washington was Canadian, and of the 31 or 32 treaties he had signed nine had been treaties relating to the affairs of Canada. "By those nine treaties," he said, "we have, I hope, dealt with all the questions that are likely to arise between the United States and Canada—questions relating to boundary; questions relating to the disposal and the use of boundary waters; questions relating to the fisheries in the international waters where the two countries adjoin one another; questions relating to the interests which we have in scaling in the Behring Sea, and many other matters." He could boast that he left the relations between the United States and Canada on an excellent footing.

For his services he was created a viscount in 1913, and in 1914, his old university, Oxford, gave him an honorary degree.

Along with other English scholars, who had ties of close association with German learning and German savants, he was extremely reluctant in the last days of July 1914 to contemplate the possibility of war with Germany; but the violation of Belgian neutrality and the outrages committed in Belgium by German troops brought him speedily into line with national feeling. He was appointed chairman of a strong committee to consider the evidence of such outrages not only in Belgium but in France; and his report convinced the most incredulous of the reality of the charges. He welcomed warmly the entrance of the Americans into the war in the spring of 1917. He also presided, as an eminent constitutional lawyer, over a committee set up in that year to consider the reconstruction of the House of Lords, and spent much labour in a task which all parties were disposed to shirk. During these latter years he was largely engaged on the composition of a valuable book, published in two substantial volumes, in 1921, on *Modern Democracies*, a comparative study of a certain number of popular governments in their actual working. For this monumental work he had been gathering material for several years before the war. Besides visiting Switzerland and other parts of Europe, he availed himself of his experiences in the United States and in Canada, and journeyed to Spanish America, Australia and New Zealand. Lord Bryce married, in 1880, Elizabeth Marion, daughter of Thomas Ashton, of Hyde, and sister of the 1st Lord Ashton of Hyde. He was appointed O.M. in 1907 and G.C.V.O. in 1918.

**BUCCLEUCH, WILLIAM HENRY WALTER MONTAGU-DOUGLAS-SCOTT, 6TH DUKE OF** (1831-1914), British politician (see 4.712), died at Montagu House, Whitehall, Nov. 5 1914. He married in 1859 Lady Louisa Hamilton, daughter of the 1st Duke of Abercorn, and one of the seven sisters depicted by Disraeli in *Lothair*. She was an intimate friend of the royal family, and was mistress of the robes to Queen Victoria and Queen Alexandra. She died at Dalkeith March 17 1912.

**BUCHAN, ALEXANDER** (1829-1907), British meteorologist, was born at Kinrosswood, Kinross, April 11 1829. He was educated at the Free Church normal school and the university of Edinburgh. From 1848 to 1860 he worked as a teacher, but in 1860 was appointed secretary to the Scottish Meteorological Society, and in 1869 published his first series of monthly charts showing the mean distribution of atmospheric pressure over the globe, which remained for many years a landmark in the progress of meteorology. In 1878 he became curator of the library of the Royal Society of Edinburgh, and in 1887 a member of the meteorological council of the Royal Society. He published a *Handy Book of Meteorology* (1867); *Introductory Textbook of Meteorology* (1871); besides a report on *The Weather and Health of London* (with Sir Arthur Mitchell), and edited sections on *Oceanic Circulation* (1895) and the volume on *Atmospheric Circulation* (1889) in the voyage of H.M.S. "Challenger." He received the Makdougall-Brisbane prize (1876) and the Gunning Victoria Jubilee prize (1893) of the Royal Society of Edinburgh, besides the Symons medal of the Royal Meteorological Society, and was elected a fellow of the Royal Society in 1898. He died at Edinburgh May 13 1907.

**BUCHAN, JOHN** (1875- ), British author, was born at Perth Aug. 26 1875, the son of the Rev. John Buchan. He was educated at Glasgow University and Brasenose College, Oxford, where he won the Stanhope historical essay prize (1897) and the Newdigate prize for poetry (1898), and graduating first class in *literae humaniores* (1899). In 1901 he became private secretary to Lord Milner, then High Commissioner for South Africa, and remained with him till 1903. In 1906 he joined the Edinburgh publishing firm of Thomas Nelson & Sons. Even as an undergraduate he had "commenced author" with *Sir Quixote* (1895), and he followed this with other tales and novels. His African experiences suggested *The African Colony* (1903), *A Lodge in the Wilderness* (1906), and *Prestor John* (1910). During the World War he served with the headquarters staff of the British army in France (1916-7), attaining the rank of colonel, and later was Director of Information under the Prime Minister (1921-8), and his *History of*

the *War (Nelson)* was an admirable piece of work. He wrote too some excellent tales of adventure, notably *The Thirty-Nine Steps* (1915) and *Greenmantle* (1916). Later works include *The South African Forces in France* (1920), and a biography of *Francis and Riversdale Grenfell* (1920).

**BUCKLE, GEORGE EARLE** (1854- ), English editor and man of letters, was born at Tiverton-on-Avon, Som., June 10 1854, eldest son of Canon George Buckle of Wells. He was educated at Winchester and New College, Oxford, being a scholar of his college, and graduated first class both in *literae humaniores* (1876) and in modern history (1877). He won the Newdigate prize poem in 1875. In 1877 he was elected to a fellowship at All Souls College, which he held until 1885. In 1880 he joined the staff of *The Times*; four years later, at the age of thirty, he succeeded Thomas Chenery as its editor. This position he occupied for nearly thirty years, retiring in Aug. 1912. When Mr. Monypenny, the biographer originally entrusted with the official *Life* of Disraeli, died in 1912 leaving his task unfinished, Mr. Buckle took over the work of completing it; under his authorship vol. 3 was published in 1914, vol. 4 in 1916, and the concluding vols. 5 and 6 in 1920.

**BUCKMASTER, STANLEY OWEN BUCKMASTER, 1ST BARON** (1861- ), English lawyer and politician, was born at Wandswoth Jan. 9 1861. He was educated at Christ Church, Oxford, and in 1884 was called to the bar, becoming a K.C. in 1902. He entered politics as a Liberal, and in 1906 was elected M.P. for Cambridge. In 1910 he lost his seat, but in 1911 was elected for the Keighley division of Yorks., and the same year became counsel to Oxford University. In 1913 he was made solicitor-general and knighted. He was from Sept. 1914 to May 1915 director of the Press Bureau. In the latter year he was Lord Chancellor, being raised to the peerage, but was displaced on the fall of the Asquith Government in 1916.

**BUCKNER, SIMON BOLIVAR** (1823-1914), American soldier and political leader (see 4.732), died in Munfordville, Ky., Jan. 8 1914. He was the last surviving major-general of the Confederacy and the then oldest living graduate of West Point.

**BUCKNILL, SIR THOMAS TOWNSEND** (1845-1915), English judge, was born at Exminster April 18 1845, the son of Sir John Charles Bucknill (1817-1897), a famous mental specialist. He was educated at Westminster school, and afterwards at Geneva. He was called to the bar in 1868, became a Q.C. in 1885, and a bencher of the Inner Temple in 1891. From 1885 to 1899 he was recorder of Exeter. He sat as Conservative member for Mid-Surrey from 1892 to 1899, in which year he was raised to the bench and knighted. He died at Epsom Oct. 4 1915.

**BUDAPEST** (see 4.734).—In 1920 the civil pop. of Budapest was 863,735, showing an increase of 20.55% in the decade. To this must be added a garrison of 16,636 men, making a total pop. of 880,371. Of the total pop. 756,070 were Magyars, 78,882 Germans, 20,359 Slovaks and the small remainder was composed of Poles, Ruthenians, Serbs, Croatsians, Rumanians and others. According to religion there were 526,175 Roman Catholics, 9,428 Greek Catholics, 6,962 Greek Orthodox, 86,990 were Protestants of the Helvetic and 43,562 of the Augsburg Confessions, 203,687 were Jews and the remainder belonged to various other creeds. During the World War the extraordinary increase in the population of Budapest diminished, the census Jan. 1 1921 showing a pop. of 1,184,616.

In the years immediately preceding the war there were over 6,000 students at the university, and from 4,000 to 5,000 at the Polytechnic Institute. A new faculty of political economy was founded at the university in 1919, and the Geological and Meteorological Institutes are also of recent foundation.

The new Tisher rampart in Romanesque-Gothic transition style, with a bronze statue of St. Stephen, rises round the Matthias church. At the N. extremity of the fortress is the Gothic building of the National Archives, unfinished in 1921.

The development of Budapest came to a standstill during the war, and the lack of housing accommodation caused great distress among the increased population. The city suffered

severely during the Bolshevik ascendancy, and many robberies were committed by the Rumanian troops who occupied it in disregard of the decisions of the other Allied Powers (see HUNGARY). Fortunately, the English, American and Italian missions prevented the sacking of the museums and art galleries.

See Eugen Cholnoky, "The Geographical Position of Budapest," *Bulletin of the Hungarian Geographical Society*, 1914-20, abridged.

**BUDGE, SIR ERNEST ALFRED WALLIS** (1857- ), English archaeologist, was born in Cornwall July 27 1857 and educated at Christ's College, Cambridge, where he became Assyrian scholar and Tyrwhitt Hebrew scholar. In 1885 he became keeper of the Egyptian and Assyrian antiquities in the British Museum, and he conducted excavations at Assuan, at Gebel Barkal on the island of Meroe (the site of the capital of ancient Ethiopia), at Nineveh and Der in Mesopotamia (1888-9) and in the Sudan, when the ancient monuments on the banks of the Nile were threatened with inundation by the raising of the Assuan dam. His long list of publications includes *The Gods of Egypt* (1903); *The Egyptian Sudan* (1907); *The Nile* (1910; 12th ed. 1912); *Literature of the Ancient Egyptians* (1914); *By Nile and Tigris* (1920), and very many others. He was knighted in 1920.

**BUENOS AIRES** (see 4.752) continued to be in 1921 the largest city in Latin America, the largest city in the world south of the equator and the fourth city in the two Americas, being exceeded only by New York, Chicago and Philadelphia in the order named. In total shipping, Buenos Aires ranks as the second port in the two Americas, coming directly after New York. The pop. in 1920 was 1,676,041, an increase of 486,379 or 38%, since 1909, when Buenos Aires had 1,189,662 inhabitants, and an increase since 1914 of 184,062, or 12%. It will be seen that the relative growth for the period 1914-20 was not so great as previously. This is partly accounted for by the fact that between 1914 and 1918 there was a balance against Argentina in migration of 213,000 people; however, this movement turned the other way in 1919, and in 1920 the balance resulted in favour of Argentina by 39,800. A large proportion of immigrants remain in Buenos Aires, in spite of the efforts of the Argentine Government to distribute them. In 1919, only 6,675 building permits were granted, as against 19,538 in 1910.

The celebration of the Argentine Centenary in 1910 in Buenos Aires drew many visitors not only from all Argentina, but also from abroad. In 1913 new diagonal avenues were begun, the plan being to change the rectangular pattern which had been followed since the colonial period by cutting diagonal avenues through the city on the model of Washington and Paris. The two chief new ones were to radiate from the corners of the central Plaza de Mayo, formerly the chief central square of the city. In 1921 only about five blocks of each of these avenues had been completed, the World War putting a stop to the extensive expenditures upon the project, which involved the widening of alternate streets coming from the river and the demolition of many of the older parts of the city. The parkway lying between the river and the Rio de la Plata was greatly improved during the 10 years 1910-20, much land was reclaimed from the river, and a new post-office and custom-house were erected on this parkway, adding greatly to its beauty. The centenary gifts of various nations to Argentina now adorn important parts of Buenos Aires. Among them may be especially mentioned the handsome clock tower erected by the British colony at a cost of £50,000, which stands opposite the new railway station opened in 1916 (the largest railway station in South America), the statue of George Washington in Palermo Park erected by the U.S. colony, and other statues from the French, Syrian and other foreign communities. The statue erected by the Spanish colony in Palermo Park is particularly beautiful.

The Congress building was finished in 1912 and the park in front of it, the Plaza del Congreso, covering three city blocks, was opened for the centenary celebrations in 1910, over \$500,000 having been spent.

Buenos Aires transacts approximately 80% of the entire foreign trade of the republic. It continues to be preëminently the banking, as well as the industrial, centre of the country. The first branch of a U.S. national bank ever established abroad was opened in Buenos Aires Nov. 10 1914, by the National City Bank of New York. Since then two other U.S. banking institutions have opened branches there. The number of U.S. business houses in Buenos Aires increased from 10 in 1910 to 66 in 1920, while the British and French firms and those representing other Allied countries also became more numerous. The war was very injurious to German

enterprises in Buenos Aires, many of them practically going out of business.

Other improvements in the decade 1910-20 were the erection of a number of thoroughly modern hotels and of a greatly improved immigration station; the opening of 80 new parks and plazas; the construction of several new school buildings; the extension and enlargement of the medical faculty of the university of Buenos Aires; and the erection of the large building which houses its faculty of commerce. Improvements in sanitation and sewerage have also been effected and a new subway was installed in 1912 by a German firm. Several large modern office buildings have been put up since 1916, chiefly with English capital, and new department stores, almost wholly operated with English capital. (C. L. C.)

**BUFFALO** (see 4-754).—The population in 1920 was 506,775, an increase of 83,660 or 19.6% for the decade, as compared with 71,328 and 20.2% for the preceding decade. The death-rate of Buffalo in 1920 was 12.08, the average from 1900 to 1920, 15.18. In 1914 a new commission charter was adopted which did away with the bicameral city council and mayor formerly in existence. The first commission government took office Jan. 1 1916.

The citizens choose by direct non-partisan nomination and election a mayor and four councilmen. These constitute the sole legislative body and are also the chief executive heads. The mayor is *ex officio* the head of the departments of fire, police and health, which comprise the Department of Public Safety. The four other departments are Finance and Accounts, Public Works, Parks and Public Buildings, and Public Affairs. A councilman is appointed as head of each of these departments. The principal subordinate officials are nominated by the mayor and appointed by the council. The mayor has a vote in the council, but no veto power. All ordinances and appropriations for purposes outside ordinary city expenses may be referred to vote of the people on petition of 5% of the citizens who voted at the last regular election for mayor.

The schools are under a board of education appointed by the mayor and council, but subject mainly to state laws. The city court, consisting of a chief judge and seven associate judges, is also under state law. A technical and four other high schools were built between 1902 and 1920. The sum of \$8,000,000 was appropriated for new grammar schools in 1919. The university of Buffalo was given an endowment fund of \$5,200,000, raised by popular subscription, in 1920. In 1909 it acquired a site of 106 ac. in the northern part of the city, to which 44 ac. were added in 1919. Canisius College (Jesuit) also, in 1920, raised by popular subscription an endowment fund of \$1,000,000. D'Youville College for women (Roman Catholic) was opened in 1908. Among important new structures may be mentioned: Marine Trust Co., Erie County Savings Bank, New York Telephone, Electric, Iroquois and Y.M.C.A. buildings. The new city hospital was under process of development in 1921. The city also maintained the J. N. Adam memorial hospital for tuberculous patients at Perryburg, N.Y.

The new Erie canal, rebuilt by the state as a barge canal at a cost of \$150,000,000, was opened for traffic in 1919. It provides water transportation to the seaboard for barges up to 2,000 tons' capacity and drawing not more than 12 ft. of water, adding greatly to the city's commercial facilities. The city completed in 1915 a new pumping station and tunnel 6,500 ft. long, by which water is brought from Lake Erie. The capacity of the plant is 150,000,000 gal. each 24 hours.

The city's greatest growth in recent years has been in manufactures. It has very diversified industries, producing 58% of all the different lines of goods recognized by the United States Census Bureau. Among the chief manufactures are: iron and steel products, meat products, soap, cars, flour, lumber, linseed oil, clothing, automobiles, etc.

The grain elevators in Buffalo harbour had in 1920 a capacity of 28,500,000 bushels. The receipts of grain by lake boat in 1920 were 108,825,000 bushels. Receipts of flour approximate 5,000,000 bar. yearly. More than 20,000 carloads of live stock are handled yearly in the stock-yards at East Buffalo. Other important articles of commerce are: iron ore, in which Buffalo stands second in receipts among the lake ports; coal, flax-seed, manufactured iron and steel and lumber.

Buffalo furnished over 10,000 volunteers and selected service men to the U.S. army in the World War. The greater number of these served in the 77th and 78th divisions and had an active part in the Argonne and other battles. In addition, the 74th Infantry, N.G.S.N.Y., became the 108th Infantry in the United States service; the Third Field Artillery, N.G.S.N.Y., became the 106th Field Artillery; Troop I, N.G.S.N.Y., became the 102nd Trench Mortar Battery, and Base Hospital No. 23 was recruited in Buffalo. The 108th regiment, forming a part of the 27th division, participated in the breaking of the Hindenburg line near Le Cateau, France, Sept. 29-Oct. 1 1918.

The 106th Field Artillery and 102nd Trench Mortar Battery were in the battle of the Argonne. Nearly 4,000 Buffalo men served in the navy and about 1,000 in the U.S. marine corps. There were also over 600 Buffalo men who volunteered for the Polish army. The Buffalo men who died in the war numbered 966.

Recent important books on the history of the city are *History of Buffalo* (1911) by J. N. Larnod, and *An Old Frontier of France* (1917) by F. H. Severance. (M. M. W.)

**BULGARIA** (see 4-772). *Political History 1908-12*.—The condition of Macedonia and Thrace, which since the Treaty of Berlin in 1878 had been a constant source of anxiety and difficulties for Bulgaria, became even worse under the regime of the Young Turks. The Serbs, whose hopes of reunion with their own kin and of an outlet on the Adriatic had been destroyed by the annexation of Bosnia and the Herzegovina by Austria-Hungary in 1908, began to seek expansion in Macedonia towards the Aegean. Rival bands of Serbs, Greeks, Bulgars, Wallachs, Albanians and Turks now carried on the propaganda of their respective nationalities in Macedonia by force of arms, and the life of the peasant became unbearable. The perpetual menace of war with Turkey and, latterly, the strained relations with Greece and Serbia, entailed on Bulgaria a military expenditure which in 1909 was proportionately higher than that of any other European state. Bulgaria was obliged, moreover, to support thousands of destitute refugees who had escaped over her frontier from Turkish territory; current consular reports stated that the Bulgarian population of Macedonia had diminished to a quarter of what it had been 15 years earlier. There was again a fear that the Young Turks meant to exterminate the Bulgars of Thrace and Macedonia altogether, and the Macedonians living in Sofia, many of whom were men of ability and influence, were continually urging the Government to take energetic steps with regard to Macedonia.

*The Balkan Alliance*.—In March 1911, the Malinov Cabinet fell and Gueshov, head of the Nationalist party, became president of the council. Balkan statesmen were slow to realize that it was to their common interest to put an end to the troubles in Macedonia, and that this could be done only by joint action. In the winter of 1910-1, negotiations in this direction were begun at Athens between Bulgaria and Greece, the first negotiations taking the form of private conversations between J. D. Bourchier, principal *Times* correspondent in the Balkans, and Venizelos. Eventually, Venizelos entrusted Bourchier with the transmission to King Ferdinand of a definite proposal which was known only to King George, Venizelos and Bourchier; the greatest secrecy was observed throughout, even after the matter had been put on a diplomatic footing. In June 1911, the Grand Sobraney empowered the Government to make secret treaties without submitting them to the Sobraney. In May 1912, a treaty of defensive alliance between Bulgaria and Greece was signed, but this treaty was kept entirely secret for the next two months. Meanwhile, negotiations had also taken place between Bulgaria and Serbia, and in Oct. 1911, the Serbian premier, Milovanovitch, and Gueshov came to a general agreement as to terms of an alliance. The negotiations with Serbia proved difficult throughout. The Bulgars were in favour of autonomy for Macedonia; the Serbs, in favour of dividing the country into three zones, an uncontested Serbian zone, an uncontested Bulgarian zone and a contested zone, the fate of which should be left to the arbitration of the Tsar of Russia. After much discussion in which both sides showed an uncompromising spirit, a treaty of friendship and alliance, with a secret annex, was signed in Sofia on March 13 1912. By this treaty Serbia recognized "the right of Bulgaria to the territory E. of the Rhodope Mountains and the river Struma"; while Bulgaria recognized "a similar right of Serbia to the territory N. and W. of the Shar Mountains"; if autonomy for the rest of Macedonia was found to be impossible, the two states bound themselves to accept an agreed line running southwards from Golem Mountain to Ochrida Lake, should the Tsar of Russia pronounce in favour of this line. Russia was kept informed of the negotiations; the Tsar's Government, while it welcomed the *rapprochement* between the three Orthodox states, discouraged active measures, but events in Turkey tended to force the hands of the allies. In June 1912, the Young Turk Government fell; a serious Albanian rising led to the concession of a measure of autonomy to the Albanians; there was a bomb outrage at Kochen, followed by a massacre of Bulgars by Turks; Bulgaria considered herself menaced by proposed Turkish military manoeuvres near Adrianople. The Great Powers, which had by the autumn become aware of the Balkan alliance, made efforts to prevent the outbreak of war, which culminated in a proposal from Austria-Hungary that the Powers should guarantee

the autonomy of Macedonia. Unfortunately, the offer came many years too late. On Sept. 30, the Balkan allies ordered the mobilization of their armies, and on Oct. 8 Montenegro, with which country no formal agreement had been made, declared war on Turkey. On Oct. 13, the allied Balkan Powers sent a virtual ultimatum to the Porte; on Oct. 17, Turkey declared war on Serbia and Bulgaria, and on Oct. 18 Greece declared war on Turkey.

**First Balkan War 1912-3.**—The war with Turkey was popular throughout the country, for the people of Bulgaria, though they are often represented as self-centred and materialistic, had felt the sorrows of their kinsfolk in Macedonia as their own, and were prepared for any sacrifices in order to set them free. The campaign in Thrace brought out once more the admirable qualities of the Bulgarian soldier, his power of endurance, his courage and his obedience to discipline, but the success of the campaign was in reality less complete and satisfactory than it appeared to be in press accounts. The Bulgars, it is true, forced the Turkish army back in disorder, after severe fighting near Kirk-Kilisse and Lule-Burgas, to the strong defensive position of the Chatalia lines; but, owing to lack of heavy artillery, they failed to capture Adrianople and proved unable to force the Chatalia lines and so to advance on Constantinople. For all its supplies, the army was dependent on ox transport; nearly every cart and draught animal in Bulgaria had been requisitioned. The rough tracks by which supplies had to travel had been rendered almost impassable by rains, and it was fully ten days' trek from the railhead at Yambol to Lule-Burgas; there was heavy mortality among the draught animals. The enforced pauses, whilst the army was waiting for supplies to come up, twice gave the Turks time to withdraw and finally permitted them to reorganize their forces at Chatalia. The campaign had revealed great shortcomings in the medical and supply services, and the Bulgars suffered only a degree less cruelly than the Turks themselves from shortage of food and absence of sanitary and medical care. The assaults on Chatalia, which cost the Bulgars some 10,000 casualties, were undertaken contrary to the advice of Fichov, chief of staff, and were inspired by Ferdinand, whose ambition it was to take Constantinople regardless of the cost. Fichov, who had realized that the troops were too much exhausted after the five weeks' fighting in Thrace to follow up their success to complete victory, was compelled by the King to ask for sick leave and was succeeded by Nerzov.

On Dec. 4 an armistice between Turkey, Bulgaria and Serbia was signed. At this moment the position was everywhere favourable to the allies. The Greeks, who did not sign the armistice, had occupied most of southern Macedonia and held Salonika. The Serbs, after heavy fighting at Kumanovo and Prilep, had taken Monastir, and the Turkish army had retreated into Albania. The Turkish fortresses of Scutari, Yanina and Adrianople still held out, but their garrisons were suffering from shortage of supplies. The signatories of the armistice met in London to arrange terms of peace. The Bulgarian demands, which included the *vilayet* of Adrianople and the port of Rodosto on the Sea of Marmora, seemed likely to be accepted by the Turks, but a *coup d'état* in Constantinople brought the Young Turk party back to power, and as the Young Turks seemed as determined to hold Adrianople as the Bulgars were to obtain it, the conference was broken up. On Feb. 3, 1913, hostilities again began. Yanina surrendered early in March, the Serbs and Bulgars entered Adrianople almost simultaneously on March 25, and Scutari fell a month later. After the surrender of Adrianople, the Turks sought the mediation of the Powers, and after another conference in London, the delegates were, on May 30, 1913, induced to sign a treaty, the terms of which had been drafted by the Powers. Turkey surrendered to the allies all her possessions in Europe up to a line drawn from Enos on the Aegean to Midia on the Black Sea, Midia being about 63 m. from Constantinople. Albania was granted independence. The Bulgarian casualties in the war were officially given as 93,000, while the Serbian and Greek official figures of their respective casualties were given as 31,000 and 29,000.

**Rupture of Balkan Alliance.**—The discussions at the conferences in London had shown that considerable friction existed between the allies. Apart from the antagonism of national character and the mutual distrust and dislike, which events in Macedonia during the last few years had accentuated, the difficulties which now presented themselves arose from the interpretation of the treaties of alliance. The military successes of the allies had been unexpectedly complete, and had thus created a situation which had not been foreseen in the treaties of alliance. The Serbs claimed that as new conditions had arisen, the treaties should be revised as a whole, and the arbitration of the Tsar should be sought for all matters in dispute. The Bulgars characteristically held out for the letter of the agreement as regards territorial arrangements, and they were, moreover, unwilling to submit even the contested zone to the arbitration of the Tsar, as they doubted his impartiality. By Article 2 of the secret annex to the treaty between Bulgaria and Serbia (March 13, 1912) it had been agreed that "all territorial gains acquired by combined action . . . shall constitute the common property (*condominium*) of the two allies," and the lines of partition, to be effected within a period of three months after restoration of peace, were then laid down. Serbia, however, as a result of her victories in Macedonia,

held much of the territory which had been assigned by the treaty to Bulgaria; whereas Bulgaria held Adrianople and all Thrace, a situation which had not been provided for in the treaty. Moreover, Greece occupied Salonika (where a Bulgarian detachment had been left for political reasons) and many districts of southern Macedonia in which Bulgars formed a majority of the population. It was impossible for Bulgaria to give up her claim to Macedonia, where the bulk of the inhabitants were of Bulgarian nationality, as it had been for their sake that she had made immense sacrifices; on the other hand, since Serbia was now cut off from the Adriatic by the creation of an Albanian state, Serbia was naturally anxious to have access to Salonika, without having to pass through Bulgarian territory before reaching the Greek frontier. Controversy also arose as to the fulfilment of the terms of the military convention of June 1912, in which it had been agreed that Bulgaria and Serbia should each, "if no other special arrangement be made," send at least 100,000 men to the Vardar theatre of war. Serbia asserted that Bulgaria had sent only 32,000 men to the Vardar theatre, whereas Serbia had voluntarily sent 50,000 men to Adrianople to help the Bulgars, and she claimed that, without the Serbian heavy artillery, that fortress could not have been taken. It must, however, be remembered that the Thracian campaign had proved the longest, the most difficult and the most costly of the allied operations, and that the taking of Adrianople was essential to the allied cause as a whole. The Serbs, again, attributed the prolongation of the campaign to the *intransigence* of the Bulgarian delegates in London. It was evident that there was never mutual confidence between the allies, and that personal contact between the respective armies had often given rise to friction rather than good-will. Bulgarian suspicion of Serbian designs was intensified by an official circular written by Pashich in the autumn of 1912, in which he spoke of Prilep and Ochrida as belonging to Old Serbia, although both these places were within the zone allotted to Bulgaria. In Jan. and March 1913, meetings took place between Prince Alexander of Serbia and Prince Nicholas of Greece, and Bulgaria had reason to suspect that some agreement was made as to combined action against herself.

The occupation by Serbia and Greece of regions of Macedonia which had not been actually allocated by treaty to either Power seemed to Bulgaria to be assuming a permanent character. The murder of King George of Greece in March 1913 meant the removal of a factor which was for peace and moderation, whereas Bulgaria, the military party, with whom King Ferdinand was in full sympathy, had, by the early spring, gained ascendancy over the policy of the country. In April a Cabinet council was held at Adrianople when, according to Gen. Savov, it was decided to retain in Thrace only such armed forces as were absolutely necessary for defence, and to transfer the rest of the army as quickly as possible against the Greeks and Serbs in Macedonia. There were good reasons for haste, for the military authorities, with the King at their head, were now convinced that war was inevitable, and, moreover, they were aware that the troops were becoming increasingly anxious to return to their homes. The concentration of troops on the Macedonian frontier was gradually effected during June. The Serbs, on their part, had not failed to make corresponding preparations on the other side of the frontier. On June 1 Gueshov and Pashich, both of them men of moderate and prudent views, met in the hope of coming to an agreement; on the same day a treaty was signed at Salonika between Serbia and Greece. During the month of June the Tsar of Russia put all possible pressure on Serbia and Bulgaria, both directly and through his diplomatic representatives, to bring about a settlement and Nekludov at Sofia, to prevent the outbreak of hostilities, but Ferdinand's replies to the Tsar's proffered mediation showed an increasing arrogance. On May 30 Gueshov, finding that his policy of caution and moderation was not supported by the King, resigned; his place was taken by Danev, a politician who stood well with the military party and who had shown marked intractability as delegate to the London conference. On June 19 a speech by Tizza in the Hungarian Parliament indicated that Austria-Hungary considered that the Balkan states should be free to choose their own method of settling their differences.

**Second Balkan War.**—On June 29 the Bulgarian Fourth Army, acting on orders signed by Gen. Savov, made the treacherous attack on their Serb and Greek allies which alienated from Bulgaria the sympathy and respect of Europe, and proved the first step towards her downfall. The manner of the attack was unjustifiable, but it must be remembered that the attack was not unexpected, and that it probably forestalled a declaration of war on Bulgaria by Serbia and Greece. The treaty of June 1 between Serbia and Greece, the concerted entrenchments at Ovche Polye, the secret orders given by the Serbian commander-in-chief, Gen. Putnik, ten days before the attack and King Peter's proclamation, issued to the troops on July 1, must count as evidence that the Serbs were fully alive to the situation. On July 1 Savov forbade further hostilities; he himself was recalled a few days later. It has been officially stated that the reports of the ministerial council contain no minute ordering the opening of hostilities against the Greeks and Serbs June 29, 1913, and Danev denied in the press that his Government had ever contemplated such orders. A judicial inquiry into the causes of the second Balkan War was opened in Sofia, but was never concluded. Savov asserted that the King himself, as commander-in-chief

gave the order to attack. The war which was so rashly and unjustifiably started by the Bulgars ended in disaster for them. They were driven back on their own frontier by the Serbs and Greeks and on July 10 the Rumanians, who had given previous warning of their intentions, crossed the Danube and advanced unopposed on Sofia. A few days later the Turks retook Adrianople and invaded Bulgaria. Danev resigned and a Stambulov Cabinet was formed, with Radoslavov as prime minister. Bulgaria was thus closed in by four enemies at once and had no choice but to submit unconditionally to the Rumanian terms. On July 30 an armistice was signed at Bucharest. The failure of Bulgarian arms in the second Balkan War was due to several causes. The *moral* of the troops had suffered owing to the prolongation of the campaign in Thrace and discontent had been rife; the troops were exhausted by their forced march in hot weather from Thrace to Macedonia immediately before hostilities, while many had no inclination to fight against their late allies and brother Slavs. The war was the work of politicians rather than of soldiers. Ferdinand and his *entourage* had underestimated the strength of the Serbian and Greek forces, and they had imagined that if once both these armies could be driven out of territory which had been assigned to Bulgaria by Article 2 of the secret annex to the Serbo-Bulgarian Treaty of 1912, the Powers would acquiesce in a Bulgarian occupation of that part of Macedonia, and also of Salonika. The civil population of southern Macedonia suffered cruelly during the second Balkan War; atrocities were committed both by Greeks and Bulgars.

*Treaty of Bucharest.*—This treaty, which was signed on Aug. 10 1913 after a fortnight's conference, deprived Bulgaria of almost all her territorial gains of the first Balkan War and also of any immediate prospect of the reunion into one state of all Bulgarian-speaking people. Rumania acquired from Bulgaria that portion of the Dobruja which had been Bulgarian since 1878, from Tutraikan on the Danube to Balchik on the Black Sea. The inhabitants of this region were almost exclusively Bulgarian and it comprised some of the best cereal-growing land which had been held by the Bulgars. Serbia and Greece divided Macedonia between them, with the exception of the mountainous region of the Perin and Despotu Daghs. Bulgaria thus retained one outlet on the Aegean, in the shallow-water port of Dede Aghach; her so-called harbour at Porto Lagos consisted only of a short length of quay and a score of buildings. Turkey regained Adrianople and most of Thrace. The Balkan Wars of 1912 and 1913 thus resulted in an increase of territory for Serbia and Montenegro by four-fifths and for Bulgaria by one-fifth, while Greece almost doubled her territory. Serbia and Montenegro increased their respective populations by three-sevenths, Bulgaria by one-twentieth and Greece by two-thirds. The total casualties of the two wars were in inverse ratio to the gains of the three states concerned, viz.:—Bulgaria, 150,000; Serbia, 79,500, and Greece, 50,000. The terms of the Treaty of Bucharest—King Charles of Rumania himself said of it: "It is not a treaty, it is only a truce and it cannot last"—were punitive rather than pacific in tendency, and the attempts of Russia, and possibly of Austria-Hungary also, to secure some modifications for Bulgaria were unsuccessful.

*Radoslavov Government, 1913-4.*—On July 5 1913 the Radoslavov Cabinet, at the critical moment when they assumed office, addressed a letter to the King, which was probably inspired by him, expressing their opinion that "the salvation of our State can only be found in a policy of intimate friendship with Austria-Hungary. That policy should be adopted at once and without hesitation, because every hour is fateful. We invite you to act immediately in order to save Bulgaria from further misfortunes and the dynasty from further responsibility." This letter was signed by Radoslavov, N. Ghenadiev and D. Tonchev. In the personnel of the Cabinet the King found ready tools for the pursuance of his policy; several of the ministers, including Radoslavov and Ghenadiev, had been prosecuted for corruption, speculation and illegal practices during their previous tenure of office, and Radoslavov himself had been condemned to a term of imprisonment and loss of civil rights. The elections of Dec. 1913 gave the Opposition a majority of 14 seats in the Sobranie, although the Government had resorted to the usual methods of controlling the elections. Owing to the impossibility of forming a new Cabinet, the Sobranie was dissolved. The suffrage was now extended to the territory which had been ceded to Bulgaria by Turkey by the Treaty of Bucharest. This measure was held by some to be unconstitutional, but the efforts of the Government to conciliate the new Moslem voters and the 150,000 refugees who had been settled in this region resulted in a Government majority of ten in the new Sobranie. The Turkish deputies, many of whom were members of the Committee of Union and Progress, thus held a casting vote in the Sobranie, and, through

them, the Sublime Porte was able to exercise a direct influence on the Bulgarian Government. It became imperative to raise a foreign loan in order to meet the obligations of the country and for certain necessary constructive work. Appeal was made to France, England and Russia successively, but assistance was refused or else only offered on conditions which it did not suit the Bulgarian Government to accept. These conditions, however, can hardly have been more unfavourable than those eventually accepted from the German Disconto Gesellschaft which provided the loan of 500 million francs. By the terms of the loan the syndicate secured the control of the state coal mines, of the projected railway which was to connect central Bulgaria with Porto Lagos, and of that terminal port itself. These terms met with angry opposition throughout the country, for it was realized that Bulgaria was handing over some of her chief economic assets to Germany. The syndicate further sought to obtain the control of the export of tobacco, but, owing to strong expression of public opinion, the Government was obliged to refuse this demand. The consent of the Sobranie to the conditions of the loan was only obtained after violent protests from the Opposition, the uproar preventing the actual reading of the bill (June 1914).

*Political Parties and Public Life.*—The old broad distinctions of Russophil and Russophobic which had marked the two main political camps in the time of Stambulov, gave place later to an increasing number of subdivisions of parties, between whose respective programmes there was not always much apparent difference. Public life in Bulgaria has hitherto left a good deal to be desired; elections have not been free and ministers have not always been above reproach as regards incorruptibility, patriotism and efficiency, and they have looked on themselves as personal employees of the King rather than as servants of the nation. The King, who was always well informed as to the private affairs of his *entourage* and who knew their weak points, preferred ministers over whom he had a hold of this description. The Sobranie often showed itself amenable to the manipulation of ministers or of the King. In practice, a change of government meant a change in the holders of most government appointments. The King's control of the army was absolute; according to the constitution he was commander-in-chief, and the power of promotion and dismissal was in his hands. Each officer was made to feel that the success of his career depended on royal favour. There can be no doubt that Ferdinand used his undoubted talents and power in such a way as to delude rather than to elevate the moral standard of his country. The real life of Bulgaria, however, is not to be found in the bureaucracy, but among the peasants who form about 80% of the population. The peasants have no reason to like politics or politicians and they prefer to hold aloof as much as possible from both. It must be remembered that, in spite of corruption in high places, the standard of life among the peasants compares favourably as regards industry, morality and freedom from crime with that of any other European people.

*Period of Neutrality (Aug. 1914-Oct. 15 1915).*—At the outbreak of the World War in 1914 the great majority of Bulgars wished to preserve neutrality; from force of circumstances, however, Bulgaria was already more than half way towards the Central Powers. The policy of the Radoslavov Cabinet, the German loan, the establishment of friendly relations with Turkey, resentment against Russia for her non-intervention in Aug. 1913, together with the deep sense of humiliation and disappointment created by the Treaty of Bucharest, all combined to indicate the direction in which Bulgarian sympathy was likely to be drawn. Moreover, Macedonia, the fate of which had been the dominant factor in the policy of Bulgaria during the whole of her existence and the cause of her sacrifices in the two Balkan Wars, was now in the hands of Serbia and Greece. The Bulgarians naturally asked themselves which group of Powers would be able to help them to realize their national ideal and their material ambitions. It seemed to them unlikely that the Powers which were ranged on the side of Serbia would be willing to deprive their ally of the fruits of her victory in 1913 and to restore Macedonia to Bulgaria. The victory of the Entente might mean Russia at Constantinople, the union of the Serb peoples in one important state and the permanent loss of Macedonia. To the King, who held the direction of the policy of the country absolutely in his hands, the victory of the Entente might mean the loss of his throne and the end of his dynasty. From an early date it was clear that Turkey would join the Central Powers, while the attitude of Rumania and Greece was uncertain. Owing to her geographical position Bulgaria would evidently be unable to preserve her "benevolent neutrality" for an indefinite time. Should she abandon it, it would be to join the winning side, and there were many in Bulgaria, including the King himself, who believed that Germany was invincible.

It is not yet known at what precise moment Ferdinand secretly promised his support to the Central Powers, but the Agrarian leader, Stamboliski, as early as Aug. 1914 accused the Government of having bound itself to the Central Powers, and there are certainly indications that the decision had been taken in the early part of 1915. The Opposition press at the outbreak of war appeared to be decidedly pro-Entente, though non-interventionist in tendency. Gueshov and Stamboliski constantly pressed for an agreement among the Balkan states themselves.

During the year in which Bulgaria maintained her neutrality, the rival groups of Powers made considerable efforts to secure her cooperation. It may be that Ferdinand had from an early date committed himself to a line of policy, but among Bulgars it is thought that, had the Entente encouraged the Opposition, who represented the great majority of the people; had the mentality of the people been better understood; had the Entente been definite in the proposals which from time to time were put before Bulgaria; had these proposals been made at propitious and not always at unpropitious moments; had the Entente been skilful and vigorous in its propaganda, it might well have been that the people would have imposed their will on the rulers whom they hated and despised. But the Entente policy pursued no certain course: the Entente Governments were slow to recognize the importance of Bulgarian cooperation; they were unwilling to pay the price which was asked for that cooperation; they did not realize the importance of the personal element in dealing with the Bulgars and with the King. The best propaganda for the Entente was the declaration that they were fighting for the cause of small nations and for the principle of nationality, since to the Bulgar this declaration meant protection for the Bulgarian state and reunion with the Bulgars of Macedonia and Thrace.

The most propitious moment to secure the support of Bulgaria would have been at the time of the Russian successes in the Carpathians in 1915, as the old feeling for Russia had never died out among the peasants. The chances of winning Bulgaria for the Entente lessened after the failure to pass the Dardanelles in March. German propaganda was skilfully handled; war news came chiefly through German sources; Tarnowski, the Austro-Hungarian minister at Sofia, either from personality or from force of circumstances, apparently controlled the situation there. The Entente proposals were hedged about with conditions; at the end of May 1915, they offered the Enos-Midia line and the uncontested zone in Macedonia, provided that, at the end of the war, Bosnia and the Herzegovina had been united to Serbia. Early in June, Austria-Hungary promised to Bulgaria, as the price of her neutrality, all Serbian Macedonia as well as the territory claimed by Bulgaria and now occupied by Rumania and Greece. On June 15 Bulgaria replied to the Entente note, asking for more specific guarantees. During July personal pressure was brought to bear at Sofia by special missions—a British mission composed of Mr. O'Beirne, Sir Valentine Chirol and Mr. G. Fitzmaurice; a French mission, and, on behalf of Germany, by Prince Hohenlohe—while active negotiations continued with Turkish delegates. On Aug. 3 the Entente answered the Bulgarian note of June 15; the Entente offered to Bulgaria, if she declared war on Turkey, the occupation of half the non-contested zone at once, the fate of the rest of this zone and of the contested zone to be decided at the peace; the immediate occupation of Seres and the promise of Kavalla, if Bulgaria would renounce all claims to Salonika, Kastoria and Vodena; and the promise of the Enos-Midia line. As these terms involved the retrocession of certain territories and places then occupied by Serbia and Greece, the allied representatives in Belgrade and Athens had the ungrateful task of trying to persuade Serbia and Greece to give up what they had won by force of arms, as the price of Bulgaria's cooperation. Greece, inspired by Germany, refused absolutely to consider any cession of territory and Serbia, where the military party was at the time dominant, was equally intransigent.

On Aug. 19 Gen. Fichev, Minister of War, who was thought to be averse to further military adventures, resigned, and was succeeded by Gen. Jekov, who had lately been acting as negotiator

with the Turks. The Opposition, becoming increasingly anxious, in vain demanded that the Sobranye should meet. On Aug. 23 Italy declared war on Austria-Hungary, and on Aug. 25 Venizelos returned to power. The moment had now come when the Central Powers desired the entry of Bulgaria into the war, and the Duke of Mecklenburg, who as special personal representative of the Kaiser and from his ability and personality was known to have a strong influence on the King, was sent from Germany to make the final arrangements. On Sept. 6 a military convention and treaty between Bulgaria and the Central Powers was signed at Pless. By this convention Germany and Austria-Hungary each agreed to send six infantry divisions within a space of 30 days, and Bulgaria four infantry divisions within 35 days, against the Serbs; F.-M. von Mackensen was to be commander-in-chief of the combined force. Turkey was, if so desired, to send troops to Dede Aghach to prevent an enemy landing. Germany agreed to advance 200 million francs to Bulgaria for military expenses, and to provide as much military material as she could spare. On Sept. 10 the existence of the treaty was admitted by Radoslavov, who stated that Bulgaria was "coming in on the side of the victors." On Sept. 12 the Opposition issued a manifesto, signed by many notable Bulgars, protesting against the policy of the Government and urging all citizens to unite to prevent the fatal step; the manifesto was, however, suppressed and the Opposition then demanded an audience of the King. On Sept. 15 the Entente made a final effort to induce Bulgaria to declare war on Turkey; Macedonia was promised unconditionally and the allied troops would occupy Macedonia for the time being, if Bulgaria so desired, as a guarantee that it would eventually be handed over to Bulgaria. On Sept. 17, at 11 P.M., the King received the Opposition leaders in audience. Malinov warned the King that if Bulgaria remained neutral, she might become the battlefield between the Germans invading Serbia and the Allies who would land at Salonika; and that, if she joined the Central Powers, she would be fighting against three Balkan peoples and four Great Powers and that it would mean the end of her national existence. Stamboliski—it was the first time a representative of the Agrarians had entered the palace—put the views of his party before the King with characteristic vigour and *brusquerie*. The Agrarians, he said, desired to preserve neutrality; they demanded the convocation of the Sobranye and the formation of a national Government. He rejected all appeal to sentiment, whether on behalf of Russia or of Germany, and he warned the King that the people were still suffering from the terrible effects of the *debté* of 1913 and that they had lost all confidence in their rulers, including the King himself. He told the King that after the Treaty of Bucharest, it was only the leaders of the Agrarians who prevented a general movement against the authors of the *pogrom*, among whom the King held the chief place, and that, should the King repeat the criminal act of plunging his country into war, the leaders would not check the revolt against him but would themselves head it. Tsanov, the Radical leader, spoke with equal emphasis and sincerity. An account of the audience was published, but its circulation was forbidden, and Stamboliski was condemned to imprisonment for life on a charge of *lese-majesté*. On Sept. 22 the terms of the Turco-Bulgarian agreement were published; the Bulgarian frontier was to follow the Tunja valley as far as the suburbs of Adrianople, including the railway station, and then to follow the left bank of the Maritsa southwards at a distance of about 2 km., thus safeguarding Bulgarian railway communication between Sofia and Dede Aghach.

Mobilization was decreed on Sept. 22, the Greek army being mobilized immediately afterwards. On Oct. 4, Savinski, Russian minister at Sofia, informed the Bulgarian Government that he had been instructed to leave the country if within 24 hours Bulgaria did not break with the enemies of the Slav cause and forthwith send away the military officers of hostile belligerent states. On Oct. 5 the Bulgarian Government replied that the mobilization was a measure of internal importance only, that the landing of Allied troops at Salonika did not tend to



reassure Bulgaria as to the friendly intentions of the Entente, and that it was impossible to send away the German officers, as, with the exception of officially accredited military attachés, there were no such officers serving with the Bulgarian army. It is still maintained by the Bulgars that no German officers arrived till after the departure of the Entente ministers. On the receipt of this note the ministers representing the Entente Powers asked for their passports and left Sofia for Dede Aghach. On Oct. 12 Bulgaria declared war on Serbia; on Oct. 15 Great Britain declared war on Bulgaria, while France and Italy declared war on her on Oct. 16 and Oct. 17 respectively.

*The World War 1915-6.*—The King's proclamation to his people showed the same duplicity as had marked all his diplomatic dealings with the Entente. After enlarging on his efforts to maintain neutrality, he said: "Both groups of belligerent Powers acknowledge the great wrong inflicted on us by the partitioning of Macedonia, and both belligerent parties are agreed that the greater part of Macedonia should belong to Bulgaria. Only our treacherous neighbour, Serbia, has remained obdurate to the counsels of her friends and allies. Serbia not only refused to listen to their advice, but, inspired by envy and cupidity, even attacked our territory, and our brave troops have been obliged to fight in defence of their own land. . . . Our Allies the Serbs were then (in 1913) the chief cause of our losing Macedonia. . . . The European War is drawing to a close. The victorious armies of the Central Empires are in Serbia and are rapidly advancing." Mobilization, as eye-witnesses have stated, was not effected with the willingness which marked the mobilization of 1912—there were even attempts at mutiny in some centres—though the presence in Sofia of the Macedonian divisions to whom Serbian acts of oppression in Macedonia were a burning personal wrong and not merely a pretext for war, served to stimulate public enthusiasm. When once the country was actually at war, the Opposition became silent, partly from *force majeure* and partly from patriotic motives; all Bulgars realized that the fate of their country was at stake. Malinov, to whom the King made overtures, declined to take office in the Radoslavov Cabinet, and Stamboliski, who was perhaps the only man in the country who could have led a revolution, was already in prison. Public meetings were forbidden and a strict censorship of the press established. The Bulgarian campaign in Serbia was, in spite of gallant opposition by the Serbs, completely successful. By the end of the year the Serbian army had retreated through Albania to the Adriatic and the Entente troops had retired within the Greek frontier, which the Bulgars did not then attempt to cross, although they themselves were confident that they could have taken Salonika. But on the one hand the attitude of Greece was still uncertain, and on the other it was to the interest of Germany that Entente troops should remain at Salonika and thus reduce the numbers available for the western front. In June 1916 the Bulgarian army occupied Seres, Drama, and Kavalla. The Sobrane had met in Dec. 1915, but, in spite of the apparently complete success of the campaign, the Radoslavov Government narrowly escaped defeat in the budget debates in July 1916. Several of the Agrarian deputies who were deemed compromised by their earlier negotiations with an agent of the Entente were imprisoned, and the Government secured the return of their own supporters in their place. On Aug. 27 1916 Rumania declared war on Austria-Hungary and, in spite of the efforts of Malinov and others to induce the Government to remain neutral, Bulgaria declared war on Rumania on Sept. 1. This war was, however, more popular than the campaign against Serbia, for the resentment caused by the action of Rumania in July 1913 was specially bitter. The Bulgarian troops were, nevertheless, unwilling to cross the Danube, as they considered that their work was finished when once the Dobruja was again in their possession; some mutinies even took place. Though the Bulgarian forces here were commanded by Gen. Tochev, F.-M. von Mackensen actually directed the operations, and, almost immediately, friction developed between the allies, resulting in Tochev's supersession. The harvest of 1916 was not a good one; the whole

population was rationed for meat, bread, sugar, rice, soap and salt, and considerable discontent arose when it was found that large quantities of produce, especially of wheat and eggs, were going to Germany. German officials took over the technical control of the railways, especially the Macedonian, Dobruja and Trans-Balkan lines, which were worked with great efficiency; the railway employees remained Bulgarian. The Germans did not otherwise interfere with the civil administration of the country, while, on the military side, they restricted their active intervention to the broader issues in the conduct of the campaign. In addition to the larger formations which Germany contributed to the Bulgarian fronts in accordance with the military convention, many German technical units reinforced the Bulgarian army and were allotted to the more important sections of the front: these included machine-gun, artillery, air force, wireless and railway construction units, and hospital staffs. These units were highly efficient, and, on the whole, the two personnel worked amicably together. In Nov., Moastir was taken by the allies.

1917.—In March news of the revolution in Russia roused once more the instinctive sympathy of the Bulgars for Russia. No stenographic reports of the debates in the Sobrane have been published, but it is known that the Opposition pressed their view that Bulgaria, having gained Macedonia and the Dobruja, should now retire from the war. A war credit of 350 million levas was, however, voted in March. It was by no means certain that Bulgaria's allies would allow her to retain all her gains; neither Germany nor Austria-Hungary was willing that Bulgaria should remain in northern Dobruja, and Turkey opened negotiations for the return of that portion of the Maritsa valley which had been ceded to Bulgaria by the Turco-Bulgarian agreement of 1915. During the summer secret negotiations were carried on in Switzerland between agents of the Entente and Bulgarian agents, but though Ferdinand may have been aware of the negotiations, the Bulgarian representatives lacked the authority and personality necessary for bringing matters to a definite issue. In Oct. the Kaiser visited Sofia and attempted, by the bestowal of decorations, to restore cordial relations with Bulgaria, but it was a matter of common knowledge that the personal relations between the Kaiser and the King were anything but friendly.

1918.—The winter of 1917-8 brought a further shortage of supplies and increased discontent and suffering. The Bulgarian soldier had been accustomed to campaigns which, though they entailed severe fighting and hardships, had only lasted a short time: in the Serbo-Bulgarian War of 1885 fighting had lasted a fortnight; in the first Balkan War, some six months; and in the second Balkan War, a nominal 40 days. The Bulgarian women had as a matter of course replaced the men in all agricultural work, but the Bulgarian soldiers, most of them peasant proprietors, were anxious to be at home for the harvest, and their restlessness showed itself in an increased number of desertions. Trench warfare was, moreover, peculiarly uncongenial to troops who were accustomed to open warfare. In Jan., Germany ceased to pay the annual subsidy of 50 million francs, which she had given Bulgaria since she entered the war, and after March she sent her no further supplies of munitions and equipment. The publication of President Wilson's Fourteen Points (Jan.) had great influence on feeling in Bulgaria. Relations had never been broken off with the United States, and attempts were made to induce the President to promise Macedonia to Bulgaria. Articles in praise of the United States were allowed to appear in the press, and the Bulgars, on their part, professed to be ready to desist from the offensive which was then projected, and to make a separate peace. In May, Rumania signed the Treaty of Bucharest, by which the Dobruja was ceded to the Central Powers in *condominium*, Bulgaria regaining what Rumania had taken from her in 1913. In June the Radoslavov Cabinet, which was despised and detested throughout the country, fell and the King selected Malinov to form a new ministry. The change of Government did not mean a definite change of policy, and Malinov was reproached later for not insisting at once on a separate

peace, as he fully realized that all was not going well. At home, the new Cabinet endeavoured to improve the food conditions and to put an end to the corruption and inefficiency in the public service which had prevailed under Radoslavov. After the Austro-Hungarian defeat in Albania in July, when it became necessary to extend the Bulgarian front still further, the Bulgars pressed Germany to send the help which from the first had been promised to them. Of the six German divisions guaranteed by the military convention, only three had actually materialized and when at last German troops, in response to further urgent appeals, began to arrive in Bulgaria, the Bulgarian line had already been broken, Serbs were at the frontier and Allied troops were actually invading Bulgaria. On Sept. 25 Malinov asked for an armistice and delegates left at once for Salonika accompanied by the diplomatic representative of the United States. On Sept. 30 the Armistice was signed, the Bulgars accepting the Allied terms unconditionally. Stamboliiski, who with other Agrarian deputies had been in prison since 1915, was released on Sept. 25 and went immediately to the front where there was great unrest among the troops. At one moment it seemed probable that a revolution would take place and a republic be proclaimed, and there was serious fighting outside Sofia in which many lives were lost, the German troops being employed to restore order. On Oct. 4 the King was informed by his ministers that he had better abdicate; that same night he left Sofia by train, having nominated his son Boris as his successor. His departure was received with absolute indifference by the people; there were no demonstrations either of regret or joy. Radoslavov fled the country immediately afterwards. On Nov. 28 Malinov resigned, as a protest against the installation of Rumanian officials in the southern Dobruja contrary to the terms of the Armistice. Todorov, who had been Gueshov's second in command, succeeded in forming a coalition Cabinet.

*Treaty of Neuilly.*—On Nov. 27 1919 the Treaty of Peace between the Allied and Associated Powers and Bulgaria was signed at Neuilly-sur-Seine, Stamboliiski signing on behalf of his country. The territorial provisions (Arts. 27-35) included the cession to Rumania of the southern Dobruja; the cession to Serbia of the Bulgarian towns of Tsaribrod and Strumitsa and the renunciation (Art. 48) "in favour of the Principal Allied and Associated Powers of all rights and title over the territories in Thrace which belonged to the Bulgarian Monarchy, and which being situated outside the new frontiers of Bulgaria . . . have not at present been assigned to any State." The Powers undertook "to ensure the economic outlets of Bulgaria to the Aegean Sea."

At the conference of San Remo in April 1920, a small portion of Eastern Thrace was assigned to Turkey and the remainder of Thrace to Greece. Bulgaria was not represented at the conference, though some 400,000 Bulgarians were concerned in the decisions as to Thrace; the Bulgarian delegate who had been sent from Sofia in the hope that the Allies would allow him to put the Bulgarian case before them was prevented by the French authorities from crossing the Italian frontier until the session had practically concluded.

The reparation (Arts. 121-146) payable to the Allies was fixed at two and a quarter milliards of francs (gold) or £90,000,000 sterling, to be paid in half-yearly instalments within 37 years; the cost of the armies of occupation and of various commissions was also to be borne by Bulgaria. The Reparation Commission, which began work in March 1921, could at their discretion reduce or postpone particular payments and could assume full control and management of the taxes and sources of revenue.

The military clauses (Arts. 64-104) provided for the disarmament of Bulgaria. The total numbers armed with rifles, including military forces, gendarmes, frontier and forest guards and police, were limited to a maximum of 33,000 men. The troops were to be recruited on a voluntary basis and to be exclusively employed for maintenance of order and frontier guard duties. All officers were to be regulars, serving for 20 consecutive years;

other ranks were to serve for 12 years. Only one military training school and one State controlled munition factory were allowed. The manufacture of tanks, armoured cars, poison gas and aeroplanes, the export and import of arms, instruction in the use of arms in schools, clubs or organizations, arrangements for mobilization, new fortifications—were all prohibited. Only four torpedo boats and six motor boats were permitted, all without torpedoes and all manned by civilian crews. No artillery of calibre greater than 4·1 inches was authorized. All surplus war material had to be destroyed or surrendered within three months of the signing of peace.

Recruiting for the forces as constituted by the treaty proved very unsatisfactory, as but few Bulgars of a good stamp could be induced to leave their homes for a long period of service.

In Aug. 1919, elections were held which resulted in the following distribution of seats:—Agrarians, 86; Communists, 47; Social Democrats, 28; Nationalists, 19; Danevists, 8; Radicals, 8; Radoslavists, 3. The Agrarians had been weakened by the secession of Draghiev and his followers in 1915, and even with the support of Gueshov and the Nationalists, were in a minority in the Sobrane. Stamboliiski became prime minister. In Feb. 1920, the Sobrane was dissolved; new elections gave the Agrarians a majority of two, and in April, Stamboliiski became premier of a Cabinet composed of his own supporters. In the course of the year 1920 Bulgaria was admitted into the League of Nations.

*Finance and Trade.*—The following table shows the effect of the wars on finance and trade:—

Year	Revenue	Expenditure	Imports	Exports
1913	£5,705,344	£4,738,832 <sup>2</sup>	£7,571,921	£3,733,190
1914	£10,279,800	£10,276,504	£9,659,612	£6,177,000
1918	£19,244,000 <sup>1</sup>	£19,176,560 <sup>2</sup>		
1921	£84,628,800 <sup>1</sup>	£95,759,232 <sup>2</sup>		

The budget estimates for 1921-2—the financial year begins in April—thus showed a deficit of over £11,000,000. The consolidated and non-consolidated debts, including the war indemnity, amounted to £909,434,547, and, further, there was liability for military pensions, which would, for the next few years, amount to 7 or 8 million pounds annually. The outlook, according to the Finance Minister, was not very satisfactory. The debt per head of the population was £240 (as against £6 in 1912), and taxation had, in his opinion, reached the highest possible limit, viz. 500-540 leva per head. The townspeople had suffered much more than the peasants both during and after the war; according to the director of statistics, the annual bread budget for a family of five was 17 times higher in 1920 than in 1900; the meat budget was 28 times higher; and clothing showed a very large increase in price. During the World War, the savings banks had, owing to high prices for agricultural produce, shown a steady increase of deposits, but in 1919, withdrawals exceeded deposits by £800,000; and in 1920, by about £300,000. In 1920, although Bulgaria comprised 25% more land fit for cultivation than in 1911, cultivation had decreased by 20% as compared with 1911, and her production of cereals was smaller than in 1911. On the other hand, owing to the greatly increased selling price of tobacco—it had risen from 1 to 2-50 francs per kilo before the World War to 36 francs per kilo in 1919—the area cultivated in tobacco was more than double in 1920 what it had been in 1911; also the 1920 potato crop was double what it was in 1911. The attar of rose industry, which in Europe is almost peculiar to Bulgaria, naturally suffered during the wars, and only 15,000 ac. are now under rose cultivation; it is estimated that, although the demand for rose essence is now increasing, several years must pass before the industry is fully reestablished and equipped with modern machinery.

Bulgaria's international trade had always been primarily with Austria-Hungary and Germany owing partly to the fact that the Danube has hitherto constituted her chief means of communication and partly to the fact that these countries made a more careful study of Bulgarian markets than seemed worth the while of more distant countries. For the first six months of 1920-1, imports, which reached £68,000,000, nearly doubled exports in value. After the treaty, Bulgaria's unfavourable rate of exchange tended to direct her commerce yet more towards Central Europe.

*Communications.*—Better means of communication and capital are needed to develop the natural resources of the country—forests, mines and water power. Railway construction practically ceased with the outbreak of the first Balkan War in 1912, but the Trans-Balkan Trnovo-Stara Zagora line was completed since that date.

<sup>1</sup> All conversions are made at the pre-war rate of 25 leva to the £; in 1921, 32-35 leva went to the £; in April 1921, about 345-350.  
<sup>2</sup> Excluding war expenditure. <sup>3</sup> Budget estimates.

and proved of great importance during the World War for the transport of war material from the Central Powers to Turkey. In 1912, Bulgaria owned about 1,200 m. of normal gauge railway; in 1920 about 1,600 m., including some 250 m. of 2 ft. gauge which had been laid for military purposes. The following are among the railways projected and partly constructed:—

1. Rakovitsa-Mastanli, part of the line planned in 1913 to connect central Bulgaria with Porto Lagos on the Aegean. Length, about 60 m.; gauge, 30 in.

2. Saramba-Myana-Nevrokop, passing through the pine forests of the Upper Myana. Length about 110 m.; gauge, 30 in.

3. Medzra-Vratsa-Vidin, begun in 1906 and now in operation as far as Alexandrovo, 25 m. from Vidin.

Some 500 m. of link lines and some short lengths of railway for the exploitation of forests are also projected, but work is held up for lack of funds. A law of 1921 sanctioned the construction of railways not only by local bodies but by individuals, and special privileges were offered in the hope of attracting private enterprise. In 1921, Bulgaria owned some 9,900 m. of telegraph line, and some 2,700 m. of telephone line. There were four fixed radio-telegraphic stations: Sofia (Telefunken to kilowatts) Varna (Marconi). Shumen and Kjustendil, Kjustendil being not yet completed; according to the terms of the treaty, these stations may only be used for commercial purposes.

**Social Conditions.**—The programme of the Agrarian Government under the leadership of Stamboliiski was framed primarily in the interests of the peasants in contradistinction to those of the bourgeoisie. Some of the measures already in operation or contemplated in 1921 evoked much hostile criticism on the part of the Opposition, but though they involved some radical changes there seemed no probability of an outbreak of Bolshevism in Bulgaria. Stamboliiski had no wish to change the constitution, and King Boris had won the respect and affection of the people. The peasants were too much attached to their own homes and to their own way of life to desire great changes, provided they were spared further wars and were given a fair chance of peace and prosperity.

The Bulgars have always put a high value on education, and statistics show a steady increase in the number of those able to read and write; in 1910, Bulgaria ranked first in this respect among Balkan peoples, having 33.7% of literates, and in 1919-20, only 17% of the children of school age had failed to attend school; but the type of education so far provided had led to the overstocking of the clerical professions and to the neglect of technical occupations. The educational programme of the Agrarian Government aimed at giving a more practical bent to instruction generally and at affording equal opportunities to all classes of the community. The total period of compulsory education was to be extended from four to seven years; a large number of additional primary schools had already been opened and many *pro-gymnasias* were to be established, as well as professional schools, where a training could be obtained in agriculture, industries and practical science. Great results, both material and moral, were expected from the law of May 1920 which imposed a period of forced labour on all members of the community. This law, as originally drafted, provided for one year's service for all males on completion of their 20th year and six months for females on completion of their 16th year, the time being devoted half to theoretical training and half to manual labour on works of public utility. Bulgaria's neighbours, however, suspected that a military organization of the country might be effected by means of this compulsory service and, in deference to the Council of Ambassadors, the law had not been fully put in force in the spring of 1921. All classes of the community now give ten days' service annually to the State, and the results of the reconstruction work undertaken—bridge building, road making, repairs to buildings, forestry, etc.—seem satisfactory. Much, of course, depends on the technical supervision provided and on the practical organization of the work. School children, numbering 600,000, and students devoted in March-April 1921 a week to manual labour—cleansing buildings and streets, preparing gardens, planting trees, etc.

Other legislative measures taken include up to May 1921 expropriation of Crown and Church lands as well as of private properties of over 300 *decares* (say 75 ac.), the expropriated land being allotted to landless peasants; the commandeering of private houses for public purposes or for the accommodation of necessitous families; and proceedings by court-martial under Article 4 of the Law for Prosecution of War Criminals, against persons accused of being parties to the entry of Bulgaria into the World War and of contravention of laws during the war. The prosecutions resulted in long terms of imprisonment and heavy fines, and were naturally regarded by those affected who belonged to the *bourgeois* class, as vindictive and arbitrary acts of oppression. The Sobranie assented in March 1921 to the prosecution of Radoslavov and his Cabinet for violation of the constitution, notably by raising a loan in Germany with the object of directing the policy of Bulgaria towards the Central Powers and by declaring war on Serbia in 1916 without the consent of the Sobranie.

**Bibliography.**—H. N. Brailsford, *Macedonia, its Races and their Future* (1905); Victor Bénard, *La Macédoine, Pro Macédoine* (1897, 1904); Sir E. Pears, *Turkey and its People* (1911); F. Howell, *Campaign in Thrace* (1913); W. Miller, *The Ottoman Empire 1801-1913*

(1913); Noel Buxton, *With the Bulgarians* (1913); Sir R. Rankin, *Inner History of the Balkan War* (1914); J. G. Schurman, *Balkan Wars 1912-1913* (1914); Lt.-Col. Immanuel, *La Guerre des Balkans de 1912-13* (1913); Anonymous, "Questions militaires," "Bulgares contre Serbes," *Revue Bleue* (1913-4); A. de Pennequin, *La Guerre des Balkans, la campagne en Thrace en 1912* (1913), *40 Jours de Guerre* (1914); H. Barby, *Bregalnitsa* (1913); Boucabeille, *La Guerre Turco-Balkanique* (1913); Carnegie Endowment for International Peace, *Report of the International Commission to Enquire into the Causes and Conduct of the Balkan War* (Washington, 1914); R. W. Seton-Watson, *Risks of Nationality in the Balkans* (1917); A. Diplomatist, *Nationalism and War in the Near East* (1915); L. Gueshov, *The Balkan League* (1915); Nekludov, *Diplomatic Reminiscences, 1911-1917* (1920); Balkanico, *Aspirations of Bulgaria* (1915), *Diplomatsicheski Dokumenti po namerata na Bulgaria v evropeiskata voyna*, vol. i, 1913-1915 (1920); M. Dunan, *Le Bulgare, 1915* (1917); Noel Buxton and C. L. Leese, *Balkan Problems and European Peace* (1919); Leland Buxton, *Black Sheep of the Balkans* (1920); G. Clenton Logio, *Bulgaria, Problems and Politics* (1919); Bulgaria, "Nations of To-day" Series (1921); Treaty of Peace between the Allied and Associated Powers and Bulgaria and Protocol (London, 1920); Léon Lamouche, *La Question Macédonienne et la paix; le traité de paix avec la Bulgarie* (1919); J. Cvijich, *Remarks on the Ethnography of the Macedonian Slavs* (1906); M. Bogichevich, *Causes of the War, with special reference to Serbia and Russia* (1920); Publications Plumon, *La Bulgarie, la vie technique et industrielle* (1921); M. Turdakov, *Exposé sur la situation financière de la Bulgarie* (1921); J. D. Bourchier, *The Final Settlement in the Balkans* (1917); *The Four Treaties of Bucharest* (1918); *Echo de Bulgarie* (Sofia, 1920-1). (E. F. B. G.)

**BULLARD, ROBERT LEE** (1861— ), American soldier, was born at Youngsboro, Ala., Jan. 15 1861. He graduated from West Point in 1885 and was appointed first lieutenant in 1892. He served in various capacities in the Spanish-American War, and in the Philippines from 1902 to 1904. He was made lieutenant-colonel in 1906. In 1907 he was special investigator for the U.S. provisional Government in Cuba, and the following year was superintendent of public instruction there. In 1911 he was promoted colonel, and in 1917 brigadier-general. He commanded the Second Brigade of the 1st Division of the A.E.F. in France in 1917 and was made major-general N.A. From the middle of Dec. 1917 to the middle of July following he commanded the 1st Division and from Oct. 1918 to the following July the Second Army. In Nov. 1918 he was appointed major-general in the regular army.

**BULLEN, ARTHUR HENRY** (1857-1920), British man of letters, was born in London Feb. 9 1857 and educated at the City of London school and Balliol College, Oxford. He was the son of George Bullen, sometime keeper of the Printed Books at the British Museum. In earlier life he was a schoolmaster, but subsequently devoted himself to literary work. He became known as an authority on Elizabethan literature, and particularly for his discoveries of long-lost lyrics in the Bodleian and Christ Church libraries at Oxford, and his rediscovery of Campion in 1889 after nearly 300 years of neglect (see 5.138). For several years he was a partner in the publishing house of Lawrence & Bullen, and after its dissolution founded the Shakespeare Head press at Stratford-on-Avon in 1904, which he conducted until his death, but which was afterwards sold to B. H. Blackwell of Oxford. He died at Stratford-on-Avon Feb. 29 1920.

**BULLEN, FRANK THOMAS** (1857-1915), British novelist, was born in London April 5 1857 and was educated for a few years only at a dame school and Westbourne school, Paddington. When he was nine years old his school life came to an end, and he was employed as an errand boy for a time. In 1869 he went to sea, serving before the mast, and travelled to all parts of the world in various capacities including that of chief mate. In 1883 he gave up this seafaring life and became a clerk in the Meteorological Office until 1889. His reputation was made over the publication of *The Cruise of the "Cachelot"* (1906); and he also wrote, amongst other books, *Idylls of the Sea* (1899); *Sea Wrack* (1903); *The Call of the Deep* (1907) and *A Complete Sea Cook* (1912), besides many articles and essays. He died at Madeira March 1 1915.

**BÜLOW, BERNHARD HEINRICH KARL MARTIN, PRINCE VON** (see 4.793).—Prince Bülow, after his resignation of the German chancellorship in 1909, lived principally at the villa in Rome which he had purchased with a view to his retirement.

Part of the summer he usually spent at Flottbeck near Hamburg or on the island of Norderny. A large fortune left him by a cousin, a Hamburg merchant, enabled him to live in elegant leisure and to make his house in Rome a centre of literary and political society. He employed his leisure in writing for the centenary celebrations of the Wars of Liberation, a remarkable book on Imperial Germany, extolling its achievements and defending the main lines of his own foreign policy (Engl. translation, M. Lavenex, 1914). In a revised edition (Engl. translation 1916) he omitted or altered many passages which seemed compromising in the light of the World War, e.g. his exposition of his policy of hulling Great Britain into a sense of security, while the great German navy was being constructed. He was understood to be in deep disfavour with William II., who never forgave him his attitude and action with regard to the *Daily Telegraph* interview in 1908.

On the outbreak of war Bülow found opportunity to identify himself publicly with the German cause, and, from his own point of view, he doubtless felt what, after Germany's collapse, was made a ground of bitter reproach to him, that no one had been more actively identified than he with the main lines of the German policy which led up to the war.

He was once more to be employed in the service of his country, this time on a desperate enterprise. Italy, which had declared her neutrality at the outbreak of the war, did not eventually confine herself to the declaration that the *casus foederis* had not arisen for her as a member of the Triple Alliance. She had already intimated (July 5 1914) through diplomatic channels that she considered the action of Austria-Hungary against Serbia to be aggressive and provocative. On Dec. 9 1914 Baron Sonnino addressed a note to the Austro-Hungarian Minister for Foreign Affairs, Count Berchtold, calling attention to Art. VII. of the treaty by which Italy participated in the Triple Alliance, with particular reference to the words in that clause according to which the Austro-Hungarian Government was bound, in the event of its disturbing the *status quo* in the Balkans even by a temporary occupation of Serbian territory, to come to an agreement with Italy and to arrange for compensations. By this note the questions of the Trentino and Trieste were formally opened. Austria-Hungary manifested great reluctance to enter upon the question of compensations, but Berlin was more alert and more anxiously concerned. Prince Bülow was, therefore, entrusted with the temporary charge of the German embassy in Rome, the actual ambassador, Herr von Flotow, going on sick-leave (Dec. 19 1914). He at once plunged into active negotiations, and began by expressing his entire sympathy on principle with the Italian demand for compensations. He had, however, to fight the intransigence of the Hungarian prime minister, Tisza, and Tisza's nominee, who was Berchtold's successor, Baron Burian. Bülow was from the first for the complete cession of the Trentino to Italy, but Austria-Hungary was willing to cede only part of it. Sonnino, for his part, pointed out that Italian feeling would not be satisfied even with the whole of the Trentino, but would also, in accordance with the irredentist programme, demand Trieste. Bülow continued to urge that all he could mediate for was the Trentino but that Austria would fight to keep Trieste. Early in April 1915 Italy put forward on the course of the negotiations, which were secret, her demands for the Trentino, Trieste, the Cuzolari Is., off the Dalmatian coast, the recognition by Austria-Hungary of Italian sovereignty over Vallona, etc. The negotiations dragged on till the middle of May, when Bülow made a grave but characteristic tactical mistake. He is understood to have induced the Italian premier Giolitti to come to Rome from Turin in the hope that Giolitti's following in the Chamber would be powerful enough to prevent a rupture and to bring about the acceptance of the Austro-Hungarian terms. An equally characteristic propaganda was believed to have been instituted by Bülow, in conjunction with the Austro-Hungarian ambassador Macchio, among the partisans of Giolitti behind the back of the Italian Government. The prime minister, Salandra, suddenly resigned. There was a

great outburst of popular indignation, fanned by the impassioned eloquence of d'Annunzio and finding expression in demonstrations in front of the Quirinal (the royal palace) and on the Capitol, the municipal centre of Rome. After a great majority in the Italian Parliament had on May 20 expressed confidence in Salandra, general mobilisation was ordered on May 22, and the formal declaration of war against Austria-Hungary followed on May 23 1915. On May 24 Bülow left Rome.

During the war he lived in Berlin, and although since the peace he has again resided in Rome for part of every year, he spends many months in Germany. His name was mentioned in a ministerial crisis of 1921 as a possible chancellor, but he was entirely inacceptable to the vast majority of the German people and of the Reichstag. (G. S.)

**BÜLOW, KARL VON (1846-1907)**, German field-marshal, was born in Berlin March 24 1846 and joined the 2nd Guards regiment of infantry in 1864. He gained distinction at Königgrätz in the war of 1866, served through the Franco-Prussian War of 1870, winning the Iron Cross (2nd class), and, after holding various staff appointments, became colonel of the 4th Guards regiment in 1894. Three years later he was promoted major-general and was transferred to the War Office. In 1900 he was promoted lieutenant-general and in 1901 was general commanding the Guards division. In 1912 he attained the rank of *general-oberst* and was entrusted with the III. Army Inspection. He was thus marked out for high command, and on the outbreak of the World War he was placed in charge of the II. Army, which invaded Belgium. He occupied Liège (Aug. 7) and advanced to the Marne. He commanded the I. and VII. Armies during the retreat and at the battles of the Aisne, thus incurring responsibility in the eyes of the public for the failure to take Paris. In Jan. 1915 he was promoted field-marshal and in June 1916 was, by his own wish, placed on the retired list. He died in Berlin Aug. 31 1907.

**BUNTING, SIR PERCY WILLIAM (1836-1911)**, British journalist, was born at Manchester Feb. 1 1836 and was educated at Owen's College, Manchester, and Pembroke College, Cambridge. In 1859 he was classed as 21st wrangler, and three years later was called to the bar at Lincoln's Inn. In 1882 he became editor of the *Contemporary Review*, and henceforth devoted himself to journalism, becoming also editor of the *Methodist Times* from 1902 to 1907 in succession to Hugh Price Hughes. In 1908 he was knighted. Throughout his life he was an active supporter of Wesleyan Methodism, being the grandson of Jabez Bunting, a distinguished Wesleyan divine (see 4.802). He died in London July 22 1911.

**BURBIDGE, SIR RICHARD, 1ST BART. (1847-1917)**, English merchant, was born in Wiltshire March 2 1847. He was educated at Devizes and Melksham and at the age of 13 was apprenticed to a provision merchant in Oxford St., London, afterwards starting in business as a provision merchant at the age of 19. Fourteen years later he became general superintendent of the Army and Navy Auxiliary Stores. In 1882 he was appointed general manager of Whiteley's, Westbourne Grove, and in 1891 entered the service of Harrods, Brompton Road, of which he was afterwards managing director. By 1916 he had increased its profits from £16,000 to over £200,000, and it had become one of the largest of the London stores. He had also done a good deal to ensure shorter working hours for shop assistants. Mr. Burbidge was the "private citizen" who anonymously presented about £30,000 to the fund for acquiring the Crystal Palace for the public in 1913. During the World War he was responsible for the building and fitting up of two hospitals in Belgium and was a member of many Government committees, including the advisory committee of the Ministry of Munitions and the committee of inquiry into the Royal Aircraft workings, of which he was chairman. He was created a baronet in 1916. He died in London May 31 1917, being succeeded as second baronet by his son R. Woodman Burbidge (b. 1892), who in 1921 became chairman of Harrods.

See Mrs. Stuart Menzies, *Modern Men of Mark* (1920).

**BURDETT, SIR HENRY** (1847-1920), English economist and philanthropist, was born at Gilmorton, Leics., March 18 1847. He began life in a bank at Birmingham, but was elected in 1874 secretary to the Queen's hospital in that city. In 1880 he became secretary to the share and loan department of the Stock Exchange and also a member of the committee of management of the Seamen's Hospital Society. Finance and hospitals, especially in connexion with nursing, were the two main interests of his life. He published *Burdett's Official Intelligence of Securities*, and also *Burdett's Hospitals and Charities*, as well as works on the National Debt, local taxation, *The Hospitals and Asylums of the World* (4 vols. with plates), and many other works on economic and hospital problems. It was largely due to him that King Edward VII. established his Hospital Fund for London. He also founded and edited *The Hospital* newspaper. He was created K.C.B. in 1897 and K.C.V.O. in 1908. He died in London April 29 1920.

**BURIAN VON RAJEJCZ, STEPHEN** (ISTVAN), BARON (1851- ), Austro-Hungarian statesman, a scion of an ancient Hungarian noble family, was born Jan. 16 1851, and early in life entered the consular service, being stationed successively at Alexandria, Bucharest and Belgrade. Then his rapid diplomatic career began. From 1882-6 he was consul-general at Moscow, and his reports describing the then little understood danger of Pan Slavism attracted attention in influential circles in Vienna. He was sent as envoy extraordinary to Sofia, where he remained for several years, and successfully represented the interests of the Vienna Government during the disturbed period following the election of Ferdinand of Coburg as Prince of Bulgaria. In the second half of the 'nineties he was minister at Stuttgart and at Athens, and in March 1903 he succeeded Benjamin Kallay (1839-1903) as common Finance Minister and supreme head of the administration of Bosnia and Herzegovina. In this latter capacity he rendered important services. Burian strongly advocated annexation of the provinces, which he regarded as the essential condition precedent to the introduction of constitutional arrangements. After the annexation he did in fact set to work with the greatest zeal on the elaboration of the provincial constitution, which was proclaimed in Feb. 1910. The extremely important *Kmet* question (*Kmet*, Slav for peasant) was settled under his ministry on general lines in the sense of the optional emancipation of the *Kmet*s. In Feb. 1912 he was relieved of his office as common Finance Minister, and in June 1913 he was appointed Hungarian minister attached to the court of Vienna. On Jan. 13 1915 he succeeded Count Berchtold at the Foreign Office. His friendly relations with Count Stephen Tisza, whose influence may well have determined Burian's selection as Foreign Minister, facilitated his intercourse with those Hungarian politicians whose opinion carried weight.

The monarchy was at that time in the midst of negotiations with Italy. Burian took part in them, but at first with reserve, since he would not hear of any cession of territory long forming part of Austria. It was not till March 1915 that, under pressure of the military situation and the influence of the German Government, he expressed his willingness in principle to negotiate on this basis. The negotiations, however, in spite of further concessions made by Burian in April and May, had no success, and served only to postpone, but not to prevent, the secession of Italy into the ranks of the Entente. Burian did great service to Austria-Hungary in the matter of the alliance with Bulgaria, and also in arranging the Austro-Turkish alliance. To the Rumanian demands he opposed a negative attitude, especially to those which involved a cession of Hungarian territory and a fundamental change in the political and social position of the Rumanians in Hungary. In this question, as in others, Burian represented the particular interests of Austria-Hungary, as opposed to Germany, and for this reason became involved in severe conflicts with the leading statesmen and army commanders of the German Empire.

In the Polish question he aimed at the Austro-Polish solution, though he realized the difficulties in its way. For he thought

that the elastic structure of the Austro-Hungarian Monarchy, and the proved stability, in the case of Galicia, of a Polish province provided with wide powers of national self-government, made this appear relatively the best solution. He absolutely refused to consent to the far-reaching demands made by Germany in return for her acquiescence in this solution. In general, he maintained the view that in military, political and economic matters Austria-Hungary must be treated as an equal partner, and opposed a determined refusal to every German demand in which he saw danger to the independence, or a limitation of the territorial power, of Austria-Hungary. He thought, incidentally, that German policy was permeated with realism, and that Germany had a very high estimate of her own achievements, and of the rewards due to them, without feeling any obligation to measure the achievements of their ally by the same standard and give full satisfaction to her partner.

On the question of peace, too, there was a sharp antithesis between the views of Burian and those of German statesmen. With Burian, regard for the special interests of Austria-Hungary stood in the foreground. He refused to contemplate the loss of Austro-Hungarian territory in the south. On the other hand, he proposed as early as Nov. 1915 that Germany should smooth the way to peace by a public declaration of her willingness to guarantee the national independence of Belgium, and in the course of the year 1916 repeatedly urged that the way should be paved for negotiation with the enemy on the basis of the renouncing of conquests in the west. The decisive refusal of German statesmen to declare such a renunciation and to define precisely the demands and concessions to be made by the Quadruple Alliance in the peace proposals, as proposed by Burian, led to severe conflict between the two Cabinets. The peace note of Dec. 12 1916, which put an end to this quarrel, was the last important official act of Burian as Foreign Minister.

A few days later he laid down his office, but was recalled by the Emperor Charles after the resignation of his successor, Count Czernin, on April 14 1918. Burian now worked energetically for the conclusion of an agreed peace, and on that account came into conflict, as he had done two years before, with the German higher command. It was only in Aug. 1918, after the breakdown of the German offensive, that the German Government declared itself ready in principle to prepare the way for an agreed peace. But in the course of the negotiations insuperable differences appeared as to the time and the form of the peace offer. Bitter exasperation was aroused in the most influential German circles when Burian, holding to his design, ignored the German veto, and on Sept. 14 1918 addressed to all the belligerent nations an invitation to end the war by diplomatic negotiations. Burian's invitation had no success; it merely heightened the confidence in victory of the enemy Powers, who, by an offensive, definitely broke the resistance of their enfeebled opponents, compelled them to accept a humiliating armistice, and forced them to prepare the way for negotiations which were intended to lead to the conclusion of separate treaties of peace. When the Vienna Government decided to follow this path Burian was no longer Foreign Minister. He had resigned in the midst of a confusion which gave reason to fear the approaching end of the state and the dynasty. (A. F. P.)

**BURLESON, ALBERT SIDNEY** (1863- ), American lawyer and politician, was born at San Marcos, Tex., June 7 1863. He graduated from the university of Texas in 1884 and was admitted to the bar in 1885. For five years he was assistant city attorney in Austin, and from 1891 to 1898 was attorney of the 26th judicial district of Texas. From 1899 to 1913 he was a member of Congress and was Postmaster-General in President Wilson's Cabinet from 1913 to 1921. Soon after taking office in 1913 he aroused a storm of protest, especially on the part of the large daily newspapers, by declaring that he would enforce the law (requiring publications to print, among other things, a sworn statement of paid circulation), which had been held in abeyance by his predecessor until its constitutionality might be confirmed. The Supreme Court enjoined him from carrying out his purpose. During the World War he issued,

in 1915, an order barring unneutral envelopes and cards from the mails, and after America became a belligerent he instituted a censorship designed to suppress treasonable and seditious newspapers. The purpose was reasonable, but it was impossible to draw an ideal line and the result was a general alienation of the press. Later he introduced the "zone system," whereby postage on second-class mail was charged according to distance. In Aug. 1918 the telephone and telegraph systems were taken over temporarily by the Government and their control vested in the postmaster-general. He was an avowed advocate of permanent Government ownership of the telegraph and telephone, and in Dec. 1918 urged legislation to that end. In Nov. 1918, five days after the Armistice was signed, he took over the cables. He aroused the hostility of labour by his opposition to organization and strikes among postal employees. As early as 1913 he had urged repeal of the law allowing them to organize. He was interested in extending the parcel post, and worked for the promotion of aerial mail service.

**BURNAND, SIR FRANCIS GOWLEY** (1836-1917), English humorist (see 4.848), died at Ramsgate April 21 1917.

**BURNET, SIR JOHN JAMES** (1850- ), Scottish architect, whose father was an architect in Glasgow, was born in that city in 1859, and was educated at the Western Academy, entering the Ecole des Beaux-Arts, Paris, in 1874. He passed three years in the studio of Pascal, whose direction and guidance had a strong influence on his future design. After his return to Glasgow Burnet's first important commission was the Royal Institute of Fine Arts, the beginning of a series of important public buildings in various places in Scotland. Amongst these are the offices for the Clyde Navigation Trust, the Glasgow Athenaeum, the Pathological Institute—an extension of the Glasgow Infirmary—and the lay-out and building for the International Exhibition at Edinburgh, in 1886. He carried out also much ecclesiastical work, notably the Barony church at Glasgow and churches at Arbroath, Brechin and Larbert. Amongst the larger business buildings designed by Burnet are the head office of the Union Bank of Scotland, and in London the important completion of the Selfridge premises, in collaboration with J. E. Graham, of Chicago. Entrusted with the addition of the new galleries at the back of the British Museum, a work which eventually took him upwards of nine years, Burnet, with a view of informing himself as to the conditions of museum design elsewhere, visited in 1895 various European galleries—Paris, Berlin, Vienna and others. In the following year he visited the United States, in order to obtain information for his designs for new laboratories for Glasgow University. He was knighted in 1914, and among his other honours were the LL.D. degree at Glasgow, and membership of the Institut de France, the Société Central des Architectes Français, and the American Institute of Architects.

**BURNETT, FRANCES ELIZA HODGSON** (1849- ), American writer (see 4.853), published in 1911 *The Little Princess, a Play for Children and Grown-Up Children, in Three Acts*. Her other later writings include *My Robin* (1912); *T. Tembarom* (1913); *A Lady of Quality* (1913); *The Lost Prince* (1915); *The One I Know the Best of All* (1915); *The Little Hunchback Ella* (1916); *The Way to the House of Santa Claus* (1916), and *The White People* (1917).

**BURNHAM, EDWARD LEVY LAWSON, 1ST BARON** (1833-1916), English newspaper proprietor, was born in London Dec. 28 1833. His father, Joseph Moses Levy (d. 1868) who married Esther Cohen, was managing proprietor of a paper manufacturing and printing company and proprietor of the *Sunday Times*. Edward Levy, who took the added surname of Lawson in 1875 in accordance with the will of an uncle, Lionel Lawson, was educated at University College school, London. On leaving school he entered his father's business, and there received a thorough training in the printing and paper trades. In June 1855, immediately after the stamp duty on newspapers had been removed, the *Daily Telegraph and Courier* (see 19.559) was started by Colonel Sleigh. In September it was acquired by Mr. J. M. Levy, in liquidation of the debt due to

him for paper and printing. Edward Levy, who was already dramatic critic of the *Sunday Times*, now became editor of the *Daily Telegraph*, and 30 years later its managing proprietor and sole director. It was not until 1903 that he relinquished this position to his eldest son. He took a leading place in English journalism, and was largely instrumental in getting the paper duty abolished in 1861. He was more than once president of the Institute of Journalists, and was active in his support of press charities, especially as trustee and treasurer of the Newspaper Press Fund. In 1909 he presided over the first Imperial Press conference, held in London; in 1920 his son similarly presided at the conference held in Canada. On Lord Burnham's 80th birthday he was the recipient of an address signed by the leading journalists of the British Empire, the United States and many European countries, expressing their sense of his great services to journalism. He was created a baronet in 1892 and was raised to the peerage as Baron Burnham in 1903. He married Harriette Georgiana (d. 1897), daughter of the actor Benjamin Webster (see 24.459). He died in London Jan. 9 1916.

His eldest son, **HARRY LAWSON WEBSTER LAWSON, 1ST Viscount Burnham** (1862- ), was born in London Dec. 18 1862, and was educated at Eton and Balliol College, Oxford. He represented W. St. Pancras in the House of Commons from 1885 to 1892, E. Gloucestershire from 1893-5, and Tower Hamlets from 1905-6, and again from 1910-6. He was also a member of the London County Council from 1889-92 and from 1897 to 1904, as well as mayor of Stepney 1908-9. He succeeded to his father's barony in 1916, and was created a viscount in 1919. In his position as editor and managing proprietor of the *Daily Telegraph* he did valuable work during the World War. In 1917 he was included in the first gazette of the new Order of Companions of Honour. He was hon. colonel of the Royal Bucks Hussars. He married in 1884 Olive, daughter of Gen. Sir Henry de Bathe, Bart., but had no son. The heir to the barony in 1921 was, therefore, his brother, Col. William Arnold Webster Lawson (b. 1864).

**BURNHAM, DANIEL HUDSON** (1846-1912), American architect, was born at Henderson, N.Y., Sept. 4 1846. At the age of ten he moved to Chicago, and was educated there and at Waltham, Mass. He worked as an architect in various offices in Chicago, and in 1871 formed a partnership with John W. Root. To them was entrusted the planning of the Chicago World's Fair (1893). On the death of Root this work fell wholly upon Burnham, who in 1891 formed with C. B. Atwood a partnership known as D. H. Burnham & Co. In 1894 he was elected president of the American Institute of Architects. His success with the Chicago World's Fair buildings soon led to his being called upon to design structures in many cities. Of these may be mentioned "The Rookery," the Great Northern hotel, the Masonic Temple, and the Railway Exchange, in Chicago; the "Flatiron Building," and new Wanamaker's store, in New York; the Pennsylvania railway station in Pittsburgh; Filene's store in Boston; the Union station in Washington and Selfridge's in London. He also was asked to propose plans for improving several cities, including Cleveland (1903), San Francisco (1905, after the earthquake), Chicago (1909), and Baltimore. In 1905 he was asked by the U.S. Government to design plans for cities in the Philippines, including Manila. He was made chairman of the national committee appointed for beautifying Washington, D.C. He died in Heidelberg, Germany, June 1 1912.

**BURNS, JOHN** (1858- ), English politician (see 4.855), held the office of President of the Local Government Board for more than eight years, during which he underwent comparatively little hostile criticism save from his old friends of the Labour party. While resisting a policy of doles, he was zealous in forwarding substantial measures of social reform; but he did not take a prominent part in the great party disputes over the budget of 1909 and the Parliament bill. His activity and success in the administration of his department were recognised—much against his own wish—by the raising of the President's salary in 1910 from £9,000 to £5,000 a year; but his policy was thought



to be too conservative even by some members of the Unionist party, and early in 1914 he was promoted to the Presidency of the Board of Trade. He held this office only six months, as in the following Aug. he could not bring himself to accept the necessity of war. He resigned without making any public statement of his reasons, and took no further active part in Parliament. At the general election of 1918 he desired to stand again for Battersea; but the local labour men required him, as a condition of their support, to become a member of the Labour party, sign its constitution, and accept its programme and whips. He refused to comply. "I do not believe," he wrote, "in political indentured labour. A war against militarism must not end in conscript members of Parliament." Accordingly he withdrew his candidature, and continued in private life.

**BURNS AND SCALDS** (see 4.860).—During the World War a large number of burns were encountered in British medical practice, in the army and the navy and in munition works. The ordinary methods of treatment were adopted, but in addition the use of hot paraffin applications was tried with very marked success. This treatment indeed is stated by its supporters to give better results than any other hitherto employed. The burn is first of all washed with normal saline or with an antiseptic such as flavine or proflavine (1-1,000): it is then dried with gauze or an electric dryer. A layer of paraffin is applied at temperature 55°-60°C. A thin layer of wool is placed over the first layer of paraffin and then a second layer of hot paraffin painted over the wool. A dressing of wool and bandage is then applied and this is changed every 24 hours. The layer of paraffin must be of sufficient thickness. It may be sprayed on instead of painted. The temperature is thus important, for if it is too high the paraffin will run.

The effect of the paraffin is largely to act as a protection, and it is claimed by some that the addition of antiseptics to the paraffin is very advantageous. Lieut.-Col. A. J. Hull of the R.A.M.C. emphasized this in a communication to the journal of the Corps and recommended that the aniline antiseptics, brilliant green or flavine, should be employed. These antiseptics owe their wide use to the work of Professor C. H. Brown, who first introduced them.

The preparation of the paraffin is thus described by Colonel Hull:—

"Take ½ gramme of brilliant green or 2 grammes of scarlet red or flavine and 40 grammes of lanoline, rub up the coloured material with the *adeps lanae hydrosus* until a highly coloured smooth paste is obtained which contains no undissolved particles of the dye; using about ½ oz. of water assists the solution of the dyes. Melt the paraffin durum (678 grammes) and add 210 grammes of paraffin malle and 50 c.c. of olive oil. Let the temperature of the resulting mixture sink to at least 65° C.; then stir in the previously prepared lanoline paste, stirring until thoroughly mixed. At about 55° C. add 20 c.c. of eucalyptus oil; stir and allow to solidify."

The scarlet is said to form the least satisfactory suspension, but its therapeutic value has caused it to be continued in use. It acts as a stimulus to healing after the burns are clean. The flavine paraffin seems to answer best for recent burns. (R. M. W.)

**BURROUGHS, JOHN** (1837-1921), American naturalist and writer (see 4.863), continued to instruct and entertain a wide public with frequent essays on out-of-door life, some of which were assembled in the following volumes: *Time and Change* (1912); *The Summit of the Years* (1913); *The Breath of Life* (1915); *Under the Apple Trees* (1916), and *Field and Study* (1919). Yale conferred upon him the degree of Litt.D. (1910), and Colgate the degree of L.H.D. (1911). He died on a train near Kingsville, O., March 29 1921, while returning from California to his country home in New York state.

**BURROWS, RONALD MONTAGU** (1867-1920), English classical scholar and archaeologist, was born at Rugby Aug. 10 1867 and educated at Charterhouse and Christ Church, Oxford. From 1891 to 1898 he was assistant to Mr. Gilbert Murray, then professor of Greek at Glasgow, and from 1898 to 1908 he was professor of Greek at University College, Cardiff. In 1908 he was transferred to the corresponding chair at the Victoria University of Manchester. He conducted excavations at Pylos and Sphacteria in 1895-6, and at Rhitsona in

Boeotia in 1907. In 1903 he became principal of King's College, London, and held that post till his death in London May 14 1920. He published *Recent Discoveries in Crete* (1907) and various papers on archaeological subjects. All his life he was a fervent Philhellene. During the World War he was in active coöperation with the efforts of M. Venizelos to protect the interests of Greece and to secure Greek adherence to the Allies, and he took a leading part, by lectures and articles, in making the problems of the Near East familiar to the public.

**BURT, THOMAS** (1837- ), British Labour politician, was born at Murton Row, near North Shields, Northumberland, Nov. 12 1837. He was the son of a miner, and himself started working in the pits when ten years of age, his education being scanty. In 1865 he was elected secretary of the Northumberland Miners' Mutual Provident Association, a post which he held until 1913, and in 1874 successfully contested Morpeth in the Labour interest, being thus (along with Alexander Macdonald) the first of the Labour members in the House of Commons. He took part in many industrial conferences, and in 1890 was one of the British representatives at the Berlin Labour congress of that year. In 1892 he was president of the trade union congress at Newcastle, and in 1892 entered the Liberal ministry as parliamentary secretary of the Board of Trade, holding this post until 1895. In 1906 he was created a privy councillor, and in 1918 resigned his seat in Parliament.

See A. Watson, *A Great Labour Leader* (1908).

**BUTCHER, SAMUEL HENRY** (1850-1910), English classical scholar, was the eldest son of Samuel Butcher, classical tutor and lecturer at Trinity College, Dublin, and subsequently Bishop of Meath. Born in Dublin April 16 1850, he went to Marlborough in 1864 and won an open scholarship for classics at Trinity College, Cambridge, in 1866. In 1870 he won the Bell scholarship at Cambridge, in 1871 the Waddington scholarship, and in 1871 and 1872 the Powis medal. In 1873 he graduated as senior classic and won a Chancellor's medal. He took an assistant mastership at Eton for a year, but returned to Trinity, Cambridge, as fellow and lecturer in classics. On his marriage in 1876 to Rose, daughter of Archbishop Trench of Dublin, he had to resign his Trinity fellowship, and was then elected tutor and "married fellow" at University College, Oxford. In 1882 he succeeded Professor Blackie as professor of Greek in the university of Edinburgh. During his tenure of this chair he became widely known, not only as a scholar, but as a judicious administrator and educational reformer. He was a member of the royal commission which was appointed after the passing of the Scottish Universities bill in 1880 to reform the whole academical system in Scotland, and which reported in April 1900. In 1902 Mrs. Butcher died, and two years later he resigned his professorship and went to reside in London. He had been a member of the royal commission of 1901 on University Education in Ireland, which produced an abortive report with eight reservations in 1903; and he was also included on the royal commission of 1906. In the latter year, on the death of Sir Richard Jebb, he was chosen as a Unionist to represent the university of Cambridge in Parliament, where his brother J. G. Butcher (b. 1853; created a baronet in 1918), a well-known barrister, had sat for many years as Unionist member for York; he made an effective maiden speech on the Irish University bill and frequently took a valuable part in debate. His grave and thoughtful style and gift of natural eloquence were combined with a charm and sincerity which won him universal respect and affection, no less in public than in private life. He was however, above all, a fine Greek scholar, full of the true spirit of classical learning, with a remarkable power of literary expression, shown especially in such publications as *Some Aspects of the Greek Genius* (1891); *Aristotle's Theory of Poetry and Fine Art* (1895); *Greek Idealism in the Common Things of Life* (1901); *Harvard Lectures on Greek Subjects* (1904) and his prose translation (with Andrew Lang) of the *Odyssey* (1899). In 1907 he was president of the English Classical Association, of which he had been one of the principal founders in 1903. He was also the first president of the Irish Classical

Association, and an original member of the British Academy, becoming its president in 1900. In 1908 he was appointed a trustee of the British Museum. Two years later his health began to fail, and he delivered his last speech on Oct. 21 1910, at the dinner given to celebrate the publication of the 11th edition of the *E.B.* by the Cambridge University Press. He died in London Dec. 2 1910.

**BUTLER, HENRY MONTAGU** (1833-1918), English educationist (see 4.882), as master of Trinity, Cambridge, displayed to the full the scholastic and administrative gifts which had distinguished his period as headmaster of Harrow. His best-known work is a volume entitled *Sermons Historical and Biographical* (1890), but in 1914 he published *Some Leisure Hours of a Long Life*, which contained excellent classical verse. He died at Cambridge Jan. 14 1918.

See Edward Graham, *The Harrow Life of H. M. Butler* (1920).

**BUTLER, NICHOLAS MURRAY** (1862- ), American educator (see 4.885), was elected a member of the American Academy of Arts and Letters in 1911. In 1912 he was chairman of the New York State Republican Convention and also a delegate to the Republican National Convention. Vice-President Sherman was renominated but died shortly before the general election, and the Republican electoral votes were cast for Dr. Butler for vice-president. He was, however, overwhelmingly defeated on the ticket with President Taft, Wilson receiving an electoral vote of 435 (40 states), Roosevelt 88 (6 states) and Taft 8 (2 states). On the outbreak of the World War in 1914 he supported the peace policy of Mr. Wilson's administration as responding, he declared, "to the best wishes and hopes of the whole people." He disapproved of the organization of the American Legion. In 1916, however, he urged America's entrance into the war. The same year he was again a delegate to the Republican National Convention, serving as chairman of the Committee on Resolutions. He favoured woman suffrage and was an advocate of the short ballot. At the Republican National Convention in 1920 he received 69 votes for the presidential nomination on the first ballot, the number gradually falling to two on the tenth and last ballot. As an educator President Butler was a bold critic of many contemporary tendencies in American education. He upheld the old theory of mental discipline, and in the face of the wide-spread vocational movement in schools and colleges remained a steadfast and eloquent defender of liberal education. Under his guidance Columbia University became a cosmopolitan institution, its total registration in 1920 approximating 30,000 (see COLUMBIA UNIVERSITY). He was chairman of the National Committee of the United States for the Restoration of the university of Louvain, destroyed by the Germans in 1914. In 1920 he resigned the editorship of *The Educational Review*, becoming instead advisory editor. He was the author of *Why Should We Change Our Form of Government* (1912); *Progress in Politics* (1913, a pamphlet); *The Meaning of Education* (1915, an enlargement of the work published in 1898); *A World in Ferment* (1917, interpretations of the war for a new world); *Is America Worth Saving* (1920); *Scholarship and Service* (1921).

**BUTLER, SIR WILLIAM FRANCIS** (1838-1910), English soldier and author (see 4.888), died in Tipperary June 7 1910.

**BUTT, CLARA** (1873- ), English contralto singer, was born at Southwick, Sussex, Feb. 1 1873. She received her musical training at the Royal College of Music, and made her debut in a students' performance of Gluck's *Orfeo* at the Lyceum theatre, London, in 1892. She possessed a contralto voice of exceptional power and wide range, and from the first became a public favourite as a ballad and oratorio singer. In 1900 she married the singer Kennerley Rumford (b. 1870), and with him sang constantly at concerts in all parts of Great Britain, also undertaking various long tours in the colonies. During the World War she devoted the proceeds of many of her concerts to war charities, and was in 1917 created D.B.E.

**BUXTON, SYDNEY CHARLES BUXTON, 1st Viscount** (1853- ), British politician and administrator, was born in

London Oct. 25 1853, the grandson of Sir Thomas Fowell Buxton, 1st Bart. He was educated at Clifton and Trinity College, Cambridge, and afterwards entered public life, becoming a member of the London School Board in 1876. He was Liberal M.P. for Peterborough from 1883 to 1885, and for Poplar from 1886 till 1914. From 1892 to 1895 he was Under-Secretary for the Colonies. From 1905 to 1910 he was Postmaster-General, and from 1910 to 1914 President of the Board of Trade. In 1914 he was appointed High Commissioner and Governor-General of South Africa, being raised to the peerage as Viscount Buxton. He retired from this office in 1920.

Lord Buxton published *Handbook to Political Questions* (1880); *Finance and Politics: An Historical Study (1783-1885)* (1888); *Handbook to the Death Duties* (with G. S. Barnes, 1890); *Political Manual* (4th ed. 1891); *Mr. Gladstone as Chancellor of the Exchequer* (1901); *The Fiscal Question* (1904).

**BYNG, JULIAN HEDWORTH GEORGE BYNG, 1st Baron** (1862- ), British general, was born Sept. 11 1862, son of the 2nd Earl of Strarford, and joined the 10th Hussars in India in 1883. He saw his first active service on the Red Sea littoral a year later, when his regiment disembarked there on their way home. He passed through the Staff College, and was a major when the South African War broke out; he was then sent on special service to the Cape. He raised and commanded the South African Light Horse, which formed part of the Natal army and was at the relief of Ladysmith. Subsequently he commanded a column with marked success and was rewarded with promotion to the ranks of brevet lieutenant-colonel and colonel. After the war he commanded his regiment for two years, was then for a year in charge of the cavalry school, and was at the head of a cavalry brigade from 1907-9, when he was promoted major-general. He spent two years in charge of a Territorial division and then, in 1912, he was sent to Egypt to take command of the army of occupation.

In Oct. 1914 he was summoned home to take the 3rd Cavalry Div. to France, and he succeeded to the command of the Cavalry Corps in June 1915. But two months later he was despatched to the Dardanelles to take charge of the IX. Army Corps there and he became responsible for the Suvla area, from which he withdrew his troops most skillfully in the following December. For this valuable service he received the K.C.M.G., his corps proceeding to Egypt; but he was almost immediately called back to the western front to take over the XVII. Army Corps, and in May 1916 he was transferred from this to the Canadian Army Corps, then formed, which he commanded for a year. The Dominion troops under his orders distinguished themselves on several occasions, especially in their capture of Vimy Ridge on April 9 1917. He had been promoted lieutenant-general for distinguished service in 1916 and was given the K.C.B.

In June 1917 he succeeded to the leadership of the III. Army, which he retained till the close of hostilities. Towards the end of Nov. he carried out the brilliantly successful surprise attack on the Cambrai front for which he was promoted full general, though the German counterstroke in Dec. largely regained the lost ground. Remaining on this front in the winter of 1917-8, his forces were on the left of the V. Army in the battles of March 1918 and were to some extent involved in its defeat, but they remained unbroken and eventually it was on their front that the enemy's attack first came to a definite standstill. Five months later they bore their full share in breaking the Hindenburg line and in the general advance. For his services Byng was raised to the peerage as Baron Byng of Vimy and Stoke-le-Thorpe, and he received a grant of £30,000. He retired from the army in 1919, and in June 1921 was appointed to succeed the Duke of Devonshire as governor-general of Canada.

**BYWATER, INGRAM** (1840-1914), English classical scholar (see 4.906), died in London Dec. 17 1914. He was a great collector of books, especially early printed Greek books, and he left a bequest to provide for the study of Byzantine Greek at Oxford.

See W. W. Jackson, *Memoir of Ingram Bywater* (1919).

**CABLE, SUBMARINE TELEGRAPH:** see SUBMARINE CABLE TELEGRAPHY.

**CADbury, GEORGE** (1839- ), British manufacturer and philanthropist, was born Sept. 19 1839 at Edgbaston, Birmingham, the son of Quaker parents, and was brought up a member of that Society. In 1861 when he succeeded to the cocoa business known later as Cadbury Brothers Ltd., it gave employment to 12 workers only, but under the management of himself and his brother Richard it developed rapidly, and in 1879 he founded for the employes the garden village of Bourville, which served as a model for other social ventures of the kind. In 1919 when Cadbury Brothers Ltd. amalgamated with the firm J. S. Fry & Son of Bristol, they employed in all 4,000 people. Mr. Cadbury became chief proprietor of the *Daily News* in 1901, and his family also acquired an interest in the *Star* in 1909. The connexion of the Cadburys and other Quaker families with these Liberal and Free Trade organs caused them to be dubbed by opponents the "cocoa press."

His second wife, **ELIZABETH CADBURY** (m. 1888), associated herself with her husband's philanthropic undertakings at Bourville and elsewhere, besides holding many responsible positions on her own account. She was president of the N.U.W.W. and also of the midland division of the Y.W.C.A., and was the author of several papers on housing and other social questions. She was made O.B.E. in Jan. 1918.

**CADOGAN, GEORGE HENRY CADOGAN, 5TH EARL** (1840-1915), British politician (see 4.932), died in London March 6 1915.

**CADORNA, COUNT LUIGI** (1850- ), Italian general, chief of the Italian general staff from July 1914 to Nov. 1917, commander-in-chief of the Italian armies in the field from May 1915 to Nov. 1917, and senator, was born at Pallanza, on Lago Maggiore, Sept. 4 1850. His father was Count Raffaele Cadorna, a distinguished soldier of the wars of the Risorgimento and the Crimea; and his uncle, Count Carlo Cadorna, was one of the outstanding political figures of the same period. Luigi Cadorna entered the army in 1866, and served in the infantry, in the artillery and on the staff, becoming colonel in 1892. His career followed the usual course and his reputation steadily increased. Lieutenant-general in 1905, he was appointed to command the Genoa army corps in 1910, and a year later he was chosen as an army commander in the event of war. He commanded one side in the manœuvres of 1911, his opponent being Caneva. The victory was adjudged to Caneva, and though military opinion was divided upon the verdict it is probable that the result of the manœuvres led to the preference being given to Caneva for the command of the Tripoli expedition. But on the death of Gen. Pollio, chief of the general staff, there was little or no question as to his successor, and on July 10 1914 Cadorna received the appointment. He found the army in a deplorable condition, both as to personnel and as to material. And within three weeks the outbreak of general war forced the problems of army reform, consistently shirked by successive Cabinets, to the front. One of Cadorna's first acts on becoming chief-of-staff was to adopt the Deport field-gun, though the artillery had already begun to re-arm with a Krupp quick-firer, and this prompt decision, which did not pass without criticism, was of the greatest value to Italy. Much was accomplished during the neutrality period, and though all efforts were handicapped by lack of money and by Italy's low industrial capacity, still, in the interval between Aug. 1914 and Italy's entry into the war, Cadorna fashioned a weapon with which it was possible to strike, and strike hard.

For 29 months Cadorna, handicapped always by lack of means, directed the operations against Austria-Hungary with insight, vigour and determination. Facile critics have found fault with his plan of campaign, but the more carefully and objectively Cadorna's plan is studied, the more it justifies itself against alternative policies. For a year Cadorna had the full

confidence of his country, and his name, indeed, began to take on a legendary colour. The first check came with the initial success of the Austrian offensive in May 1916, though he had already incurred many enmities by the ruthless dismissal of those who appeared unequal to the duties of command—a process which in a great measure attained the desired end, though the dismissals were probably too numerous and certainly cost the army some good officers, besides handicapping others by the fear of supersession. As time went on, and signs of war-weariness became visible among some of the troops, Cadorna entered the strongest protest against the policy of the Government, which, he said, permitted an anti-war propaganda which lowered the moral of the army. Cadorna's protests were largely justified. Too little was done to meet anti-war propaganda, and the soldier who went on leave often returned to the front embittered by having found his family in want, while others who had escaped military service were not only safe but were making money. On the other hand, it must be admitted that a part of the responsibility for declining moral lay at Cadorna's own door. For he did not seem to have realized fully the strain of modern war upon the troops, or understood the necessity of lightening that strain by every possible expedient. The disaster of Caporetto, a disaster due to a complex of causes, led to Cadorna being transferred from the command of the Italian armies to the newly formed Allied military council at Versailles. But before he left his command he had organized the resistance on the Piave-Monte Grappa front.

Cadorna came to Versailles under the shadow of defeat, but his personality and military insight speedily impressed his colleagues and removed the initial handicap. It was a misfortune for Italy when, in Feb. 1918, consequent upon the appointment of the Caporetto inquiry commission, it was thought necessary to remove him from Versailles. As a result of the inquiry he was placed on half-pay on Aug. 29 1918, and four days later his definite retirement was gazetted.

In March 1921 Cadorna published a book dealing with his tenure of the post of chief-of-staff (*La Guerra alla Fronte Italiana*), which effectively answered much of the criticism that had been directed against his leadership. But with the passage of time this criticism had already begun to lose force. It was no longer necessary to find a scapegoat. More and more it was seen that Cadorna had made the Italian army fit for war, and that he had conducted the campaign under grave handicaps. Perhaps the most serious defect in Cadorna's leadership was that he failed to secure the loyal coöperation of many of his subordinates. The fact that he was not always well served was to some extent due to his methods. A certain friction also characterized Cadorna's relations with two successive Governments—on his side soldierly impatience with political methods and exigencies, and on theirs resentment at his criticisms of policy. Moreover, his belief in the necessity and duty of sacrifice made him slow to realize the limits of ordinary human endurance. But his achievement was great, and he remains, in spite of the disaster that closed his career, the foremost Italian military figure of the war. (W. K. McC.)

**CAILLAUX, JOSEPH-MARIE-AUGUSTE** (1863- ), French politician and financier, was born March 30 1863. After studying law and following lectures at the Ecole des Sciences Politiques he entered the civil service in 1888 as an inspector of finance, and spent most of his official career in Algiers. Standing as a Republican candidate in the elections of 1893 for the department of the Sarthe, in opposition to the Duc de la Rochefoucault-Bisaccia, he was elected to the Chamber of Deputies by 12,929 votes to 11,737. He became Minister of Finance in the Waldeck-Rousseau Cabinet, and after its fall it was not until the Clemenceau Ministry of 1906 that he returned to office again, once more with the portfolio of Finance. In 1911 he became prime minister. Unfortunately it was his ambition to bring France and Germany

together on the common ground of finance, and he failed. He endeavoured, while he was prime minister, to meet the arrogant demands of Germany in Morocco, in the course of protracted and secret negotiations carried out mainly through Baron von Lancken, who was then Chancellor of the German embassy in Paris. These negotiations became known, notably to Clemenceau, and they directly led to the dispatch by Germany to Agadir of the gunboat "Panther" in 1911. The convention which put an end to the ensuing crisis involved the surrender by France of large tracts of the French Congo to Germany. The whole negotiations formed the subject of an inquiry by a special committee of the Senate, whose report was very unfavourable to Caillaux. Nevertheless, thanks to his undoubted qualities as a financier, he remained a great power in French politics. He fought the Three Years' Service bill with the utmost tenacity; and although that measure became law, it was he who finally, on the financial aspect of that bill, brought about the downfall of the Barthou Ministry in the autumn of 1913. His past history was of a character which made it impossible, if the Entente Cordiale was to continue, that he should return to the position of prime minister, but he joined the new Cabinet as Minister of Finance. As a financial expert he had for long identified himself with a great and necessary reform in the fiscal policy of France—the introduction of the principle of an income tax. For this principle he strove—in public, at any rate—throughout the winter of 1913. His advocacy of an income tax and his uncertain and erratic championship of proletarian ideas, alarmed all the conservative elements in the country, and throughout the winter he was attacked with increasing violence from the platform and through the press. Those attacks reached their highest point of bitterness in a series of disclosures in the *Figaro*, of a more or less personal nature. This newspaper started the publication of letters addressed by him to the second Mme. Caillaux while he was still married to the first. A tragic end was made to the *Figaro's* campaign when the second Mme. Caillaux called upon the editor, M. Gaston Calmette, and fired five shots at him on March 16, mortally wounding him. Caillaux's resignation followed at once. The elections which took place shortly afterwards resulted in a crisis of unusual bitterness, which was solved eventually by Viviani becoming prime minister. The trial of Mme. Caillaux for murder began on July 20 1914 and ended by her acquittal on the very eve of war.

During the first part of the World War, Caillaux, who was by no means a popular figure, filled the duties of an army paymaster. After one or two scenes in Paris he was sent on a mission to South America. He returned in 1915, and at once attracted every effort of the German secret service. Although taking no overt part in politics he carried on a lobby campaign; he financed newspapers, and did everything he possibly could behind the scenes to consolidate his position. He became acquainted with the Bolos and the Malvys of political and journalistic life, and his activities aroused the alarm of all French patriots. By the spring of 1917 he had become in the eyes of the public "*l'homme de la défaite*"—i.e. the man who was willing to effect a compromise peace with Germany at the expense of Great Britain. The long political intrigue (see FRANCE: *History*) which led to the advent of Clemenceau to power killed all his hopes. Caillaux was arrested, and, after long delay, tried on a charge of high treason by the High Court of the Senate, and sentenced to three years' imprisonment, the term he had already served, and to the prohibition of residence in French territory for five years and deprivation of civil rights for ten years.

**CAILLETET, LOUIS PAUL** (1832-1913), French chemist, was born at Châtillon-sur-Seine Sept. 21 1832. He was a pioneer in experimental work with the liquefaction of gases (see 16.745 and 757). He died in Paris Jan. 4 1913.

**CANE, SIR THOMAS HENRY HALL** (1853- ), English novelist (see 4.949), was created K.B.E. in 1918, in recognition of his war services, especially in propaganda work. In 1914-5 he edited *King Albert's Book*, a coöperative contribution in honour of Belgium. In 1916 he wrote a play *The Iron Hand*; another play, *The Prime Minister*, was produced at the Royalty theatre, London, in 1918.

**CAIRO, Egypt** (see 4.953).—At The census of 1917 Cairo had a pop. of 790,939, being the largest city in Africa. The Moslem pop. numbered 631,163, Christian 128,991 (including 5,589 Protestants), Jewish 29,207 and others 1,578. Classified by nationality the numbers were:—Egyptian subjects 721,972, Italians 15,655, Greeks 15,254, Ottomans 12,081; French 8,252, British 7,524 (including Maltese 1,663, and other naturalized British subjects 2,650), Russians 1,242, Austrians 1,004, Spanish 627, Rumanians 528, Swiss 280, Belgians 266.

The work of improving communications, providing the city with a new sanitary system and the preservation of ancient sites and buildings was carried on with vigour up to the time of the outbreak of the World War. A new bridge across the Nile at Bulaq was completed in 1912, after four years' labour. A carriage road to Helwan was opened for traffic in 1913. The principal works of the mala drainage system were finished in 1914. The Heliopolis oasis scheme (launched in 1906) had by 1914 resulted in the building of a handsome residential suburb, and here was erected a wireless station and a large aerodrome. This aerodrome became the chief air-station in North Africa, being the starting point for air travel to the Cape, Palestine and Mesopotamia and to Europe. During the World War the removal of the huge and ancient rubbish mounds E. of the city was undertaken; their removal offered a large and healthy site for a new suburb. In 1919 the building of various new government offices was begun.

A law passed in 1918 enlarged the scope of the department charged with the preservation of Arab monuments to include all buildings dating from the Arab conquest to the reign of Mehmet Ali, specially citing Coptic ecclesiastical buildings and the Roman fortress of Qasr Sham at Old Cairo. Important excavations were made in that fortress. The restoration of the mosque of Ibn Tulun (A.D. 879) was the chief archaeological work vigorously prosecuted during the World War. The mosque of Bibars (A.D. 1269) was in 1918-9 rescued from being a slaughterhouse and its great-courtyard turned into a public garden. Large public gardens were constructed at Bulaq and around the Daher mosque. The Sultania library was reorganized and in 1920 contained 92,000 volumes; 40,000 in the Oriental section.

All larger town-planning schemes had to be abandoned during the World War, and building activity was greatly restricted, while over 800 houses had to be demolished in 1916, having been rendered insecure by infiltration during the high Nile flood of that year. The housing difficulty remained acute in 1918.

The presence during 1914-8 of large numbers of white soldiers, unaccustomed to Oriental ways, did not, however, give rise to the trouble anticipated. The political history of Cairo is indistinguishable from that of Egypt, but mention may be made of serious rioting in March 1919, following the deportation of Zaghlul Pasha and three of his associates. (F. R. C.)

**CALGARY, Alberta, Canada** (see 4.1004), had in 1920 a pop. of 75,000. It is the centre of the ranching and grain-producing region of central and southern Alberta, the western general headquarters of the Canadian Pacific Railway, and an important station of the Royal Canadian Mounted (formerly Royal North-West Mounted) Police. Large water-power stations, lumber-mills, lighting-plants, banks, wholesale houses, first-class hotels, churches, private and public schools, and a Government creamery all go to constitute a flourishing city. Four miles south of Calgary is situated the Agricultural Experimental Station under irrigation maintained by the Provincial Government—one of the largest of its kind in the world. In addition to its prominence as a pure-bred stock centre, Calgary is fast growing as a manufacturing city, and year by year extends the range of its industries, which at present include beet sugar, soap, furniture, boilers, farm implements, and miscellaneous machinery. The city council is composed of a mayor and 12 aldermen.

**CALIFORNIA** (see 5.7).—In 1920 the pop. was 3,426,862, as against 2,377,549 in 1910, an increase of 1,049,312, or 44.1% as compared with 60.1% for the preceding decade. During 1910-20 the Japanese increased from 41,356 to 71,952; the Chinese decreased from 36,248 to 28,812. The density of pop. in 1920 was 22 to the sq. m.; in 1910 15.3. The urban pop. (in places of 2,500 or more) increased from 61.8% of the whole in 1910 to 68% in 1920, the urban pop. in the latter year being 2,331,729. Of the 185 cities in the state, only three, Los Angeles, San Francisco, and Oakland, had in 1920 more than 100,000 inhabitants. The table on the next page shows the growth during the decade 1910-20 of the 12 cities which in 1920 had a pop. of 25,000 or more.

	1920	1910	Increase %
Los Angeles . . . . .	576,673	319,198	80.7
San Francisco . . . . .	506,676	416,912	21.5
Oakland . . . . .	216,261	150,174	44.0
San Diego . . . . .	74,683	39,578	88.7
Sacramento . . . . .	65,908	44,696	47.5
Berkeley . . . . .	56,036	40,434	38.6
Long Beach . . . . .	55,593	17,809	212.2
Pasadena . . . . .	45,354	30,291	49.7
Fresno . . . . .	45,086	24,892	81.1
Stockton . . . . .	40,296	23,253	73.3
San Jose . . . . .	39,642	28,946	37.0
Alameda . . . . .	28,806	23,383	23.2

**Agriculture.**—During the decade 1910-20 the number of farms increased from 88,197 to 117,670, or 33.4%; all land in farms increased from 27,931,444 ac. to 29,365,667 ac.; improved land increased from 11,389,894 ac. to 11,878,339 ac. The value of all farm property rose from \$1,614,694,584 in 1910 to \$3,431,021,861 in 1920. The average acreage per farm decreased from 316.7 ac. in 1910 to 249.6 ac. in 1920; the average value per acre increased from \$47.16 to \$94.77. In 1920 over 4,000,000 ac. were under irrigation. Of domestic animals on farms in 1920, there were 402,473 horses, valued at \$35,416,507; 63,419 mules, valued at \$7,221,930; 1,229,086 beef cattle, valued at \$61,280,293; 778,951 dairy cattle, valued at \$59,401,153; 2,400,151 sheep, valued at \$25,906,445; 909,272 swine, valued at \$13,859,907. Poultry was valued at \$15,293,579, and hives of bees at \$1,469,447. The total wool production for 1919 was 15,216,957 lb. valued at \$6,695,461.

The following table shows comparative acreage, production and value of the chief crops for 1909 and 1919:—

	Acreage	Production	Value
Corn . . . . .	116,740	3,448,459 bus.	\$ 5,862,383
" . . . . .	1909 51,935	1,273,901 "	1,077,411
Oats . . . . .	1919 146,889	2,966,776 "	2,966,776
" . . . . .	1909 192,158	4,143,688 "	2,637,047
Wheat . . . . .	1919 1,086,428	16,866,882 "	36,938,477
" . . . . .	1909 478,217	6,203,206 "	6,323,983
Barley . . . . .	1919 987,068	21,897,283 "	35,035,654
" . . . . .	1909 1,195,158	26,441,954 "	17,184,508
Beans . . . . .	1919 471,674	6,552,951 "	30,798,869
" . . . . .	1909 157,987	3,328,218 "	6,295,457
Potatoes . . . . .	1919 63,305	8,217,937 "	18,901,258
" . . . . .	1909 67,688	9,824,005 "	4,879,449
Hay and forage . . . . .	1919 2,202,853	4,494,940 tons	96,121,846
" . . . . .	1909 2,534,235	4,331,885 "	42,206,252
Hops . . . . .	1919 8,118	12,610,955 lb.	6,557,229
" . . . . .	1909 8,391	11,994,953 "	1,731,110
Cotton . . . . .	1919 87,308	46,418 bales	9,237,182
" . . . . .	1909 324	183 "	11,714

Cotton during the decade showed a remarkable increase in production and obtained the rank of a staple crop. The production of rice passed beyond the experimental stage and in 1919, from 130,367 ac. were produced 6,926,313 bus., valued at \$20,432,627. The production of sugar beets, 843,269 tons, valued at \$4,313,981 in 1909, fell to 666,866 tons in 1919, valued, however, at \$8,669,258. In 1919 the total production of orchard fruits was 47,557,570 bus., valued at \$91,687,814. The most important were peaches (\$29,542,787), plums and prunes (\$28,381,734), apples (\$12,155,128) and apricots (\$11,815,290). The production of oranges in 1919 was 21,628,444 boxes, valued at \$67,048,178. Among the more recent commercial fruits are alligator pears (avocados), of which 7,919 crates were produced in 1919, valued at \$63,352.

**Minerals.**—The total value of mineral products for 1910 was \$86,688,347. California was the second state in gold production with 988,853 fine oz., valued at \$20,441,490. Gold production for 1919 was 841,638 fine oz., valued at \$17,398,200; silver 1,153,614 fine oz., valued at \$1,293,051. Copper production fell to 22,299,056 lb., valued at \$4,235,934, as compared with 47,674,660 lb. in 1918, valued at \$11,775,641. Lead production fell in 1919 to 4,455,161 lb., valued at \$253,944, as compared with 13,372,049 lb. in 1918, valued at \$506,087; quicksilver to 14,941 flasks, as compared with 22,621 in 1918. The oil output for 1918 was 97,531,997 barrels.

**Manufactures.**—The following preliminary figures show the growth in manufactures between 1914 and 1919:—

	1919	1914
Establishments . . . . .	11,943	10,057
Persons engaged . . . . .	296,999	176,547
Proprietors and firm members . . . . .	12,460	10,429
Wage-earners (average) . . . . .	243,794	139,481
Capital . . . . .	\$1,333,382,000	\$736,105,455
Wages . . . . .	304,523,000	105,612,681
Cost of materials . . . . .	1,218,890,000	447,474,531
Value of product . . . . .	1,981,443,000	712,800,764
Value added by manufacture . . . . .	762,553,000	265,426,233

The principal industries in 1914 were **canning and preserving**, \$61,462,849; **petroleum refining**, \$55,527,651; **lumber and timber products**, \$52,860,274; **slaughtering and meat packing**, \$50,011,820; **printing and publishing**, \$54,774,879; **foundry and machine-shop products**, \$31,732,384; **flour-mill and grist-mill products**, \$24,078,735; **bread and other bakery products**, \$21,855,181; **butter, cheese, and condensed milk**, \$20,466,428; **cars and general shop construction, and repairs by steam-railway companies**, \$17,199,717; and **beet sugar**, \$15,528,666. California ranked ninth state in the total value of manufactured products; first in the canning industry and in the production of crude petroleum; second in petroleum refining, exceeded only by New Jersey; and third in lumber and timber products.

**Communications.**—In June 1910 the total railway mileage was 7,545 m. of main track. The total mileage, Jan. 1, 1919, was 8,268, or 5.31 m. per 100 sq. m. of territory. The chief railways were the Southern Pacific, the Atchison, Topeka and Santa Fe (both trans-continental lines), and the San Pedro, Los Angeles and Salt Lake. Since 1910 there has been rapid improvement of high-ways. In that year for the first time bonds, amounting to \$18,000,000, were issued for developing an excellent system of roads. In 1916 a second issue of \$15,000,000 was made, and in 1919 the voters adopted a constitutional amendment providing for the issue of \$40,000,000 to complete the projected system. By the close of 1920 about \$36,000,000 had been expended. From June 1916 to June 1920 the improved roads had been increased from about 1,127 m. to about 2,493 m., and about 3,067 m. of the project yet remained to be improved. The larger part of the system consisted of cement concrete base with thin bituminous top. Steamship communication increased rapidly during the period 1909-20. About \$12,000,000 was expended on improving San Pedro Bay and the harbour of Los Angeles.

**Banking and Finance.**—On June 30 1920 of 723 banks reporting the capital stock paid in was \$151,585,000, and aggregate resources \$2,999,597,000. Between 1912 and 1920 the number of national banks in the state increased from 231 to 310, and their total resources from \$61,214,000 to \$1,092,956,000. During the same period the number of savings banks decreased from 132 to 106; deposits increased from \$97,139 to \$53,530, and deposits from \$407,006,665 to \$875,951,000. The average for each depositor increased from \$681.16 in 1912 to \$1,026.27 in 1920. The cash in the state treasury July 1 1910 was \$7,201,220. The receipts for the fiscal year ending June 1911 were \$18,843,854; expenditures \$18,391,471. Total receipts for the fiscal year ending June 1919 were \$50,132,900; expenditures \$50,691,433. Cash on hand July 1 1919 was \$14,140,661. On the same date the assessed valuation on taxable property was \$1,023,000,588. The net bonded debt was \$44,138,500.

**Education.**—From 1910 to 1917 the number of pupils enrolled in the public schools increased from 349,145 to 569,284, and teachers from 10,769 to 19,074. The value of school property in 1910 was \$38,661,761; in 1917 it was \$92,800,821. Expenditures for public schools in 1910 were \$6,000,000; in 1917 \$34,133,122. In 1917 the average salary in the elementary schools was \$81.74 per month; in the high schools \$1,473 per year.

**History.**—Many amendments to the constitution were ratified during the decade 1910-20. Among the more important were those for the initiative and referendum, the recall (including the recall of judges), woman suffrage, the granting of larger powers to the state railway commission, adoption of the short ballot, all these in 1911; in 1912 the provision of a uniform series of text-books for use in elementary schools together with their free distribution. In 1914 a proposed prohibition amendment to the constitution was defeated. In 1914 and again in 1920 the proposal of the Legislature that a convention be called to revise the constitution was overwhelmingly defeated. Important legislation included a workmen's compensation Act and the limiting of the hours of women's labour to 8 hours a day or 48 hours a week (1911); an Act providing for the confinement and care of drug addicts (1912); mothers' pensions; a blue sky law, designed to protect investors against unscrupulous promoters; and the sterilization of persons twice imprisoned for sexual crime (1913); provision for absent voting by those engaged in national service, for creating a state council of national defense to cooperate with the Federal Council of National Defense, and for the regulation of stages and automobiles, operating as common carriers over definite routes (1917); a compulsory part-time education law; vocational reeducation of workmen disabled in industry; raising of compulsory school age limit from 15 to 16; creation of a department of agriculture; provision of an industrial farm for the rehabilitation of fallen women; and ratification of Federal prohibition (1919).

In Nov. 1910 Hiram W. Johnson was elected governor. He had travelled through the state, attacking the "special interests," particularly the Southern Pacific railway, which he accused

of improper influence in state legislation. His remarkable success in carrying through a comprehensive programme of legislation is shown by the passage of the measures referred to. When, following the break in the Republican party in 1912, the National Progressive party was organized, Johnson was nominated for vice-president on the ticket with Theodore Roosevelt. In the succeeding election the results were extraordinarily close and long in doubt; Roosevelt secured a plurality of 174 over Woodrow Wilson, the Democratic candidate, the popular vote being 283,610 for Roosevelt and 283,436 for Wilson. In 1916 the popular presidential vote was almost equally close but reversed, 466,289 for Wilson and 462,516 for Hughes, the former receiving a plurality of 3,773. At this election women voted in the presidential campaign for the first time. In 1920 the popular vote for president was 624,992 for Harding and 229,191 for Cox. In 1916 Gov. Johnson was elected to the U.S. Senate, taking his seat on March 4 following. Beginning Oct. 9 1911 attention was centred in the trial in Los Angeles of John J. and James B. McNamara, accused of dynamiting the Los Angeles Times building (Oct. 9 1910), resulting in the death of 21 persons. The crime was one of a nation-wide series intended to prevent the use of non-union materials and non-union labour. The defendants were strongly supported by the American Federation of Labor. Later the accused pleaded guilty, and James B. McNamara was sentenced to life imprisonment and John J. McNamara to imprisonment for 15 years.

In 1913 the anti-Japanese feeling throughout the state culminated in the passage of the Webb Alien Land-Holding Act. In 1909 measures had been proposed in the Legislature aimed at preventing the ownership of land by Japanese, but at the request of President Roosevelt these were dropped. Similar measures were introduced in 1913, and on April 13 a measure to that effect passed the Assembly, containing language displeasing to the Japanese Government. President Wilson at once communicated with Gov. Johnson, urging delay, and with the approval of the Legislature and of the governor, Secretary of State Bryan went to California to counsel moderation or delay in action. But another bill drawn up by Attorney-General Webb for the same purpose passed both Houses of the Legislature on May 3 1913 and was signed by the governor May 19, to be effective Aug. 17. The first two sections of the Webb bill were as follows: (1) "All aliens eligible to citizenship under the laws of the United States may acquire, possess, enjoy, transfer, and inherit real property, or any interest therein, in this state in the same manner and to the same extent as citizens of the United States, except as otherwise provided by the laws of this state." (2) "All aliens other than those mentioned in section 1 may acquire, possess, enjoy, and transfer real property, or any interest therein, in the manner and to the extent and for the purpose prescribed by any treaty now existing between the Government of the United States and the nation and country of which such alien is a citizen or subject, and not otherwise." While this bill prevented the Japanese from acquiring land in the state, its supporters held that no treaty rights were infringed, and that Japan could not justly take offence at the language used.

For several years San Francisco had been trying to secure part of the Hetch-Hetchy valley as a reservoir for furnishing water to the city. In 1913 a bill passed Congress, granting this. The question evoked much public discussion on both sides. Gifford Pinchot, the well-known conservationist, supported the project, while the naturalist, John Muir, strongly opposed it. The Panama-Pacific International Exposition, celebrating the opening of the Panama Canal, was held Feb.-Dec. 1915, at San Francisco. At the same time an exposition was held in San Diego, devoted chiefly to the display of California products. The state supplied to the army during the World War 112,514 men (excluding officers). The subscriptions to the four Liberty Loans in order were \$100,190,900, \$159,362,100, \$174,506,200, \$201,126,700; to the Victory Loan, \$186,701,950.

Recent governors were James N. Gillett (Rep.), 1907-11; Hiram W. Johnson (Progressive Rep.), 1911-7; William D. Stephens (Rep.), 1917-.

**CALIFORNIA, UNIVERSITY OF** (see 5.22).—During the decade 1910-20 the university of California grew to such an extent that in the latter year it stood foremost in number of students among American universities. In the degree-giving departments on Nov. 1 1920 the enrollment was as follows: at Berkeley, in the schools of Letters and Science, Engineering, Agriculture, Chemistry, Commerce, Jurisprudence, Medicine (part), Education and Architecture, 8,726 undergraduates, of whom 4,757 were men and 3,969 women; and 943 graduates, of whom 484 were men and 459 women; at San Francisco, in the Hastings School of Law, schools of Medicine (part), Dentistry, Pharmacy, Hooper Foundation for Medical Research, 656 students; at Los Angeles, in the southern branch (instruction in lower division), 872 students, and in the teachers' curricula, 1,108 students; making a total, less duplicates, of 11,197. There were in the university extension division courses 13,792; in the agricultural extension courses 5,625; in the summer session and intersession courses 6,436, and on the University of California Farm 530, making a grand total, less duplicates, of 37,480.

Between 1910 and 1920 many new buildings were erected, the most important being the Boalt Hall of Law (1911), costing \$190,000, partly the gift of Mrs. Elizabeth Jesselyn Boalt as a memorial to Judge Boalt and partly subscribed to by the lawyers of California; Agriculture Hall (1912), costing \$267,000; Benjamin Ide Wheeler Hall (1917), costing \$700,000, and Hilgard Hall (1917) costing \$350,000, both buildings the gift of the people of California; Gilman Hall for the Chemistry department (1917), costing \$197,000; Sather Tower (1914), costing \$200,000 besides \$25,000 for bells; and the University Library, completed in 1917 at a cost of \$1,442,339.41, of which \$730,000 was bequeathed by Charles Franklin Doe. The number of volumes in the library was 427,930 in 1920.

After twenty years of service Dr. Benjamin Ide Wheeler resigned the office of president July 15 1919, and on Dec. 2 1919 Dr. David P. Barrows, head of the department of Political Science, took his place as 9th president. Mrs. Phoebe Apperson Hearst, for 22 years a regent of the university, died April 13 1919. Among her many gifts were the Hearst Mining Building, Hearst Hall, scholarships amounting to more than \$30,000; contributions to the Anthropological museum, \$130,000; and the swimming pool for women. The death of Henry Morse Stephens, for 17 years a professor in the university, occurred in 1919. In his memory his friends planned to erect a \$300,000 Student Union building to be known by his name, and also to raise a sum of money to support one or more travelling fellowships in Europe for university graduates in history.

The endowment of the university in 1920 was \$7,253,926.57, yielding a gross income of \$368,821.04. The total assets, including real estate and improvements, were \$23,117,236.62. From July 1 1919 to June 30 1920 the income of the university, from the U.S. Government, was \$159,338.90; from state appropriations, \$2,722,904.37; from students fees and deposits \$594,210.96; from hospitals, infirmary and the professional colleges \$501,706.83; from departmental sales and miscellaneous receipts \$546,432.09; from gifts for current use \$110,718.75; from gifts for buildings and equipment \$302,263.82; and from gifts for endowment \$530,343.86; making, with the income from endowment mentioned above, a total from all sources of \$5,844,464.13.

In the World War 4,158 men and 36 women connected with the university served with the colours. This number is exclusive of the S.A.T.C. unit at the university with 1,926 men and 56 officers, and the Naval Unit with 498 men and nine officers. Fifty-four per cent of the enlisted personnel received commissions. Of the 121 faculty members in the service, 103 were commissioned. (D. P. B.)

**CALMETTE, GASTON** (1858-1914), French journalist and writer, was born at Montpellier July 30 1858. He was educated at Nice, Bordeaux, Clermont-Ferrand and Mâcon, and afterwards entered journalism. In 1884 he joined the staff of the *Figaro*, and in 1894 became its editor. Calmette came much into public notice in 1913 and 1914 as the leader and inspirer of the bitter attacks on the policy of M. Caillaux. Almost every day the *Figaro* produced evidence of a damaging sort against the minister with the object of proving that he used his official position to facilitate speculation on the Bourse. The attitude of M. Caillaux in the Rochette case of 1911, in which it was alleged by the *Figaro* that the director of public prosecutions had been influenced by the ministry to delay the course of justice, was brought forward, and a newspaper campaign of extraordinary violence was the result. M. Caillaux was urged by some of his colleagues to take legal proceedings against his accusers, but declined. Some days later (March 17 1914) Mme. Caillaux called at the office of the *Figaro* and shot M. Calmette dead



with a revolver. The unfortunate journalist was well known for his interest in art, and possessed a fine collection of caricatures and engravings of the First Empire.

**CAMBON, PAUL PIERRE** (1843- ), French diplomatist (see 5.85), was appointed French ambassador in London in 1898. His career at the London embassy was brilliant in the extreme. He was one of the leading artisans of the Entente Cordiale, and played a very important part in frustrating the efforts made by Germany to separate France and Great Britain in 1914 on the eve of the World War and in maintaining good Franco-British relations during the peace negotiations. He resigned his post in Nov. 1920.

His brother, **JULES MARTIN CAMBON** (1845- ), had become French ambassador at Berlin in 1907, and was there when the World War opened. He reached France from his post in Berlin after a journey in the course of which he was subjected by the Germans to many indignities. He had been a close observer of Germany's year-long preparations for war. He became General Secretary of the Foreign Office during M. Briand's war term of office, a post which he occupied with distinction. He was also elected a member of the French Academy.

**CAMBRAI, BATTLE OF** (1917): see ARTOIS, BATTLES IN; also TANKS.

**CAMBRAI-ST. QUENTIN, BATTLE OF** (Aug. 26-Oct. 5 1918).—The first stage of the British offensive in Aug. 1918, the battle of Amiens, had been successfully accomplished, and the second stage, the battle of Bapaume-Péronne, was making good progress (see SOMME, BATTLES OF THE) when it was considered by British G.H.Q. that on Aug. 25 (to use the words of Lord Haig) "the proper moment had come for the third stage of the operations, in which the First Army should extend the flank of our attack to the north. By driving eastward from Arras, covered on the left by the rivers Scarpe and Sensée, the First Army would endeavour to turn the enemy's positions on the Somme battlefield and cut his system of railway communications which ran south-westward across their front." See map, Plate I.

1. *Operations of the First Army* (Aug. 26-Sept. 26).—The forces at the disposal of Gen. Horne's First Army for these operations consisted of the I. and VIII. Corps, to which the Canadian Corps was now added. This last-named formation began to arrive in the army area on Aug. 22, and was put into line on the right or southern wing of the army. Thus the front on Aug. 25, the eve of the offensive, was held as follows, from right to left: Canadian Corps (Currie) (2nd Canadian, 3rd Canadian and 51st Div. in line, 1st Canadian Div. in reserve); VIII. Corps (Hunter-Weston) (8th and 20th Div. in line, 24th Div. in reserve); and I. Corps (Holland) (55th and 16th Div. in line, 15th Div. in reserve). Of these forces, however, only those astride the Scarpe, *i.e.* the Canadian Corps, were to be engaged, the main axis of the attack being the line of the Arras-Cambrai road; the two remaining corps were to stand fast, while making all endeavours to deceive the enemy and prevent him dispatching reinforcements to other threatened points. The VIII. and I. Corps therefore will not come again into this narrative.

Facing the right of the First Army were the German I. Bavarian Reserve Corps astride the Scarpe and the II. Bavarian Corps as far south as the Arras-Cambrai railway. These two corps formed the right of the Seventeenth Army and had divisions in line. They held the old German trenches of 1916 from W. of Gavrelle in the N., by Fampoux, Feuchy, and Tilloy to Neuville Vitasse in the south. Behind them lay a succession of strongly fortified zones—first, the old British and German defences of 1917 covering all the ground W. of the Coieul river; next the Frésnes-Rouvroy line and the Vis en Artois switches and finally the Drocourt-Quéant line. To the E. of this, the last artificial position, there lay the strong natural defence line of the Canal du Nord covering Cambrai. The task upon which the First Army was about to embark was thus no easy one.

The Canadian attack was timed for 3 A.M. on Aug. 26—that is, well before dawn. Some 45 tanks were available, and owing to the absence of some of the corps artillery only 600 guns covered the advance. Two objectives were assigned, the

first running E. of Fampoux and W. of Monchy and Wancourt, the second including Roeux, Monchy and Guémappe, while exploitation was to be carried out beyond this latter line as far as possible.

The operation was carried out exactly as ordered. The Germans opposite the Canadians appear to have been warned of the attack and to have thinned out their front line, so that resistance was weak at first. Heavy fighting, however, took place for the second objective, particularly in the southern sector, where the 2nd Canadian Div. was operating; here the ridge E. of Wancourt and Guémappe was not finally secured till late at night. The 3rd Canadian Div. had pushed its troops beyond Monchy and up to the edge of Pelves by midday, while N. of the Scarpe the 51st Div., advancing at 9 A.M., occupied Fampoux and Gavrelle with little opposition. The Germans delivored counter-attacks S. of the river without success and at the end of the day the Canadians had penetrated into and maintained themselves within the enemy defences some two and a half miles to the E. of their starting points.

The operations were continued during the following two days by the same divisions in line. The 3rd Canadian Div., moving off at 4:55 A.M. on the 27th, met with steadily increasing hostile resistance, chiefly on the left in the Scarpe valley; the 2nd Canadian Div. commenced its advance only at 10 A.M. Both made progress, and by the evening had reached the line of the Sensée, between Cherisy and Rémy. The Canadians now found themselves in front of the Frésnes-Rouvroy line, which in this sector ran from N. of Hendecourt by Rémy and Boiry to Biache, and the capture of this line was assigned as the objective for the 28th. The divisions again advanced at different hours, the 3rd at 9 A.M., the 2nd at 12:30 P.M., and the brigades and battalions also attacked in succession from the left, thus enabling all the artillery available to unite in covering the advance of each unit in turn. This method proved highly successful on the left, where by the end of the day the 3rd Div. was in possession of the Frésnes-Rouvroy line along its entire front; the 2nd Div., however, despite valiant efforts, was unable to make much progress.

That night the divisions in line were relieved, the 1st Canadian Div. coming in on the right, the 4th British Div. on the left. The next few days were devoted to preparations for the attack on the Drocourt-Quéant line, timed for Sept. 1 but later postponed to the 2nd. Artillery and bridging material were brought forward and wire-cutting commenced, while a series of partial infantry attacks took place with the object of securing suitable jumping-off ground. The XXII. Corps (Godley) was now brought in on the Canadian left; the 11th Div. was put in on the N. bank of the Scarpe and the 51st and 8th taken over from the Canadians and VIII. Corps respectively; the 49th Div. was retained in reserve. As a result of the local operations carried out on both banks of the river, Arleux and Plouvain fell into the hands of the XXII. Corps, and the Canadians completed the capture of the remaining German positions W. of the Drocourt-Quéant line. By the evening of Sept. 1 all was ready for the morrow's attack.

This was to be carried out by the 1st Canadian Div. on the right, the 4th Canadian Div. in the centre, and the 4th British Div. on the left on the front from N. of Hendecourt to W. of Sully, measuring some 5½ m. in width. Five hundred guns and 45 tanks were detailed off to assist. The first objective was to be the front and support lines of the Drocourt-Quéant system; the second the W. bank of the Canal du Nord between the Arras-Cambrai road and the Scarpe, and the third a line just to the E. of that obstacle. The XXII. Corps astride the Scarpe was to secure the Canadian left. The XVII. Corps (Ferguson), on the left of the British Third Army, was to advance on the Canadian right, after the capture of the first objective, and by passing through the breach made by the Canadians to turn from the N. all the German defences in the vicinity of Quéant, where the Drocourt-Quéant line joined the main Hindenburg line.

The attack began at 5 A.M., rapidly overran all resistance and by 9:15 A.M. had possessed itself of its first objective on all its

front. The Drocourt-Quéant front and support lines were thus in the hands of the Canadians after little more than four hours' fighting. The operation had been brilliant in the extreme, but the exploitation proved more difficult, as neither tank nor artillery support was available in sufficient strength. As a result the advance on the front of the 4th Canadian and 4th British Div. made no progress beyond the line south of Etaing-Dury. On the right, however, the 1st Canadian Div. got forward beyond Cagnicourt and Villers and established its front some distance to the E. of these places. Meanwhile the XVII. Corps pushed the 57th Div. through the gap opened by the Canadians and swung down astride the Drocourt-Quéant line towards its junction with the Hindenburg line, which was at the same time assailed in front by the 52nd Division. Later in the day the 63rd Div. passed through to continue the advance; by nightfall the tangle of trenches and wire at the junction were in British hands and the villages of Quéant and Pronville had also been wrested from the enemy.

That night the German Seventeenth Army withdrew its two right corps in haste behind the Canal du Nord, where they again faced round for a renewed stand. Their losses had been heavy; 11 divisions had been defeated with a loss of close on 11,000 prisoners and many guns; the artificial defences had not held up or even appreciably checked the British advance, which now threatened to turn from the N. the whole of the Hindenburg line.

Fortunately for the Germans the Canal du Nord proved a sufficiently formidable obstacle to give pause to the First Army's progress. It was decided that that army should halt and reconstitute for the present, as any further advance could only be carried out by a deliberate and carefully planned assault on the canal line. This attack was not to take place till Sept. 27.

In their operations between Aug. 26 and Sept. 3 the 10 British divisions of the First Army had defeated 13 hostile divisions, and taken from them over 16,000 prisoners and 200 guns. The right wing of the German Seventeenth Army had been forced to fall back some 12 m., abandoning in succession a series of strong and well-fortified defensive systems, the loss of which had an instant effect on the situation to the south.

2. *Third Army's Advance to Hindenburg Line (Sept. 3-26).* As a result of the First Army's success the German Seventeenth Army on Sept. 2 was ordered to fall back to the Hindenburg line, and to commence the move that same evening. By Sept. 8 the two corps (III. and XIV. Reserve) which faced the British Third Army had completed their withdrawal and held the fortified front from Sains on the Canal du Nord by Havrincourt to just S. of Gouzeaucourt, with detachments to the W. of this line, established in the old British and German trenches of 1917.

The British Third Army followed up the retreating enemy, being impeded only by rearguards whose resistance was easily overcome, and by Sept. 9 were once more in touch with the main body of the German Seventeenth Army along the whole of its front. At this period the line was held from right to left by the V. Corps (Shute) (21st and 17th Div. in front line, 38th Div. in reserve); the IV. Corps (Harper) (5th New Zealand and 37th Div. in line, 42nd Div. in reserve); the VII. Corps (Haldane) (62nd and 2nd Div. in line, 3rd and Guards Div. in reserve); and the XVII. Corps (Ferguson) (52nd and 63rd Div. in line, 57th Div. in reserve).

In order to obtain observation and jumping-off ground for the attack on the main Hindenburg system it was necessary to clear the enemy from the positions still held by him forward of this line. This was successfully accomplished in two operations, on Sept. 12 and Sept. 18. On the former of these dates the IV. and VI. Corps in the centre of the army advanced on a front of five miles between the Cambrai-Péronne and Cambrai-Bapaume roads. The IV. Corps, attacking with the 37th Div. on the right and the New Zealand Div. on the left, occupied Trescault and the heights north of it, while the 62nd Div. of the VI. Corps carried Havrincourt after stubborn fighting and maintained it in face of a series of counter-attacks, delivered with fresh forces both on this and the following day. The 2nd Div. also made some progress to the N., effectively securing the flank of the 62nd

and keeping touch with the XVII. Corps, which had been held up ever since Sept. 2 on the W. bank of the Canal du Nord.

Sept. 18 saw the V. Corps on the right of the Third Army attacking in its turn, in conjunction with the Fourth Army to the south. The 38th Div. was brought up into line for this operation on the left of the 17th, the 21st Div. being on the right of the corps front. The attack was fairly successful, though the 21st Div. was unable to attain all its objectives and the 38th Div. was held up in front of Gouzeaucourt, and a series of further minor attacks on the succeeding days proved necessary before the positions required for the general offensive against the main Hindenburg line were completely secured along the whole front of the Third Army.

3. *Advance of Fourth Army to Hindenburg Line (Sept. 3-26).*—The results of the fighting on the line of the upper Somme and the Tortille at the end of Aug. and the beginning of Sept. had been such as to induce the German Second Army to give up all hope of putting up any further resistance W. of the Hindenburg line, and to order a withdrawal of its troops to that fortified position. Accordingly, from the morning of Sept. 4th, the British Fourth Army was able to make rapid progress along its whole front. The line at the beginning of this advance was held as follows: on the right was the Australian Corps (Monash) with the 32nd, 5th Australian and 3rd Australian Div. in line, and the 1st and 4th Australian Div. in reserve; on the left the III. Corps (Butler) with the 74th and 12th Div. in line and the 58th in reserve. Facing them the front of the German Second Army was held in order from the right by the LIV., XI. and LI. Corps; in all, eight divisions.

The first few days of the British advance passed with little resistance from the enemy, who fell back rapidly under cover of the fire of light machine-guns and isolated field guns. British cavalry and cyclists found some scope for useful activity and considerable progress was made. On Sept. 8, however, the Germans made a stand in the old British battle zone of March 21 on the general line E. of Vermand to E. of Roisel-Épéhy. A series of partial assaults by the various front-line divisions having had little result it became evident that a deliberate attack would be necessary to overcome this obstacle. Accordingly the army front was reorganized, the IX. Corps coming in on the right, taking over the 32nd Div., and putting the 1st into line on its left, with the 6th and 46th in support. Gen. Rawlinson then proposed to undertake an operation on a large scale with the object of capturing the outer defences of the Hindenburg line along the whole front of the Fourth Army. These outer defences consisted of two strongly fortified lines, the first of which had been the German outpost line in the spring of 1917 and the British main line of resistance before March 1918, and the second the British outpost line corresponding to this main line—a less formidable obstacle about a mile farther east. The capture of these defences, which would afford observation over the greater part of the main Hindenburg line proper, was of course an essential preliminary to any operation against the latter.

Accordingly the period from Sept. 11 to 17 was devoted to pushing on the preparations for this projected attack. The line was advanced in several places by means of strong fighting patrols, so as to run on the evening of the 17th from Holnon by Meissemy and Jeancourt to St. Emilie and W. of Epéhy. By this time everything was ready for the general offensive, which was timed to commence at 5:20 A.M. on the 18th in conjunction with the First French Army to the S. and the Third British Army to the north.

It was intended that the advance should be carried out in three stages, the final objective (which it was not considered must necessarily be reached on the first day) being the old British outpost line from Thorigny by Pontruet, W. of Bellicourt and of Bony to W. of Vendhuile. This gave a front of attack of some 14 m. in length and involved an average penetration of 3 miles. Twenty-three tanks joined in the attack, which was preceded by no bombardment but was covered by the fire of 978 guns.

Generally speaking the operations of the Australian Corps in the centre were completely successful, those of the IX. and III.

Corps in the wings less so. The IX. Corps, attacking with the 6th and 1st Div. in line, despite difficulties in assembling its forces, reached its first objectives by 9 A.M., but the 6th Division was held up at Holnon, and was unable to maintain itself in Fresnoy, while the 1st Div. got farther forward, but not as far as Pontruet. The corps lost heavily, though some prisoners and guns were taken. The Australian Corps (4th Div. on the right, 1st on the left) also had heavy fighting, particularly in Levercuier village and the woods N. of it, before reaching its first objective, and was checked in front of the final objective till darkness fell, when the last hostile defences W. of the main Hindenburg line were successfully secured under cover of night. The captures of the corps came to over 4,000 prisoners and 87 guns; the attacking strength of the Australians was less than 6,000 and the casualties were just over 1,000 in all. The III. Corps' attack, carried out by the 74th, 18th, 12th and 58th Div. in line from the right, met with very stubborn opposition; the enemy were expecting the attack and fought well. As a result the progress made was less than had been hoped; only the 74th Div. in fact attained the first objective. The 18th was checked after capturing Ronsoy and the 12th and 58th after taking Epéby; 2,300 prisoners were taken and 10 guns.

It was decided, in view of the incomplete success attained on this day, that the IX. and III. Corps should continue the attack on the 19th, while the Australians consolidated their gains. A series of partial offensives were therefore undertaken on the succeeding days, on both wings of the army, but with little real result; neither corps could succeed in attaining the final objectives of the first day's attack or clear the enemy entirely from the advanced defences of the Hindenburg line.

Meanwhile it had been definitely decided by British G.H.Q. on Sept. 22 that that line should be attacked along the whole front from the Sensée to N. of St. Quentin by the First, Third and Fourth Armies. To the last named were assigned as reinforcements the XIII. Corps and the II. U.S. Corps; the former was maintained in reserve, but the latter was combined with the Australian Corps and took over the left of its front and the right of the III. Corps front, relieving the 1st Australian, 74th and 18th Div. by Sept. 25. The 74th and 58th Div. now left the Fourth Army, which had thus undergone a net increase from 10 to 14 divisions.

During this redistribution the efforts of the IX. and III. Corps to gain further ground continued without cessation. Sept. 21 and 22 saw some progress by the latter formation, which was not, however, successful in completing the capture of the outer German defences before the right of its line was taken over by the 27th and 30th U.S. Div., nor were the new arrivals who carried out their first attack in France on the 26th and 27th able to advance the line to any real extent. On the other hand, during the period from Sept. 24 to 26 the IX. Corps, by repeated efforts, pushed their front to the E. of Gricourt and Pontruet, thus ensuring favourable conditions for the forthcoming offensive on the right wing of the army.

In the series of operations, described above, the Third and Fourth British Armies had engaged 15 divisions against 29 of the German Second and Seventeenth Armies, and had taken from them close on 12,000 prisoners and 100 guns.

4. *Preparations for Attack against Hindenburg Line (Sept. 22-26).*—The Hindenburg line, which now faced the British armies, has been described in detail elsewhere; it will therefore suffice to say here that, together with the Masmères-Beaurevoir line beyond it, it formed a fortified belt some four to six miles in depth, and was in all respects one of the most formidable defensive positions known to history. Despite the risks of failure and the probable consequences of such a failure, from the political and moral as well as the military point of view, it was considered essential both by Marshal Foch and Lord Haig that the attack on it should be carried out and that as soon as possible. In view of the fact that the First and Third British Armies were faced with strong positions in the Canal du Nord and the Scheldt canal, which it was advisable to carry prior to the general attack on the Hindenburg line behind the latter obstacle, it was decided that

these two armies should open their operations a day earlier than the Fourth Army, so as to draw off the German reserves from the front of that army, which had to deliver the main attack and was faced with the most formidable defences.

Accordingly the following orders were issued on Sept. 22: "The First Army will attack on Sept. 27 with a view to capturing the heights of Bourlon Wood in the first instance. It will then push forward and secure its left on the Sensée river and operate so as to protect the left of the Third Army. The Third Army will operate in the direction of the general line Le Catcau-Solèsmes. It will attack on Sept. 27 in conjunction with the First Army and will press forward to secure the Canal de l'Escourt, so as to be in a position to coöperate closely with the Fourth Army on Sept. 29. The Third Army will assist the Fourth Army with counter battery work on the enemy's guns in the region La Terrière-Villers Outréaux. The Fourth Army, protected on its right flank by the First French Army, will deliver the main attack against the enemy's defences from Le Tronquoy to Le Catelet, both inclusive, operating in the direction of the general line Bohain-Busigny. The bombardment will commence on Sept. 27 and the assault will be delivered on Sept. 29."

5. *First Army's Advance to Cambrai (Sept. 27-Oct. 2).*—At the close of the operations E. of Arras at the beginning of Sept., the right wing of the First Army, consisting of the Canadian and XXII. Corps, stood S. of the Scarpe, facing the obstacle of the Canal du Nord and the Sensée. Behind this strong line of defence the German Seventeenth Army had the I. Bavarian Reserve and the II. Bavarian Corps with five divisions in front line and about twice that number in support. The positions held by them were formidable to a degree; the Canal du Nord, although not completed along all its length, was some 100 ft. in width and its northern half full of water; all the bridges were destroyed, and the E. bank, which commanded the W., had been lined with machine-guns and strongly wired. To the E. of the canal the Germans had as successive defensive positions the Marquion trench line, running from Oisy by Marquion to the main Hindenburg line near Graincourt; the Marcoing line, covering Cambrai at a distance of some two miles from its outskirts; and the Scheldt canal, from the Sensée at Estrun by the western suburbs of the city to Marcoing, Crèvecœur and the south.

The task in front of the First Army was thus an extremely difficult one; none the less it had to be tackled, and as early as Sept. 15 the preliminary measures were taken in hand. The XXII. Corps took over the front from the Sensée southwards to the Arras-Cambrai road, and the Canadians relieved the left of the Third Army as far as N. of Moeuvres. By this means the latter, who were to make the main attack, were brought opposite a portion of the Canal du Nord, which was dry along a front of 1½ miles. The plan was to cross the obstacle here and then to expand the front of attack to a frontage of some 9 m. by pushing out divisions fanwise to E., N.E. and N. It was hoped that the assembly of the attacking troops in the restricted zone opposite the crossing point, the rapid bridging of the dry canal, and the pushing forward of guns to cover the farther advance, and of reinforcements, ammunition and supplies to support it, could all be carried out with the necessary speed and security, although the difficulties to be faced were very great and the possible causes of contretemps numerous.

Zero hour was to be 5:30 A.M. on Sept. 27. The 4th Canadian Div. was in line on the right, and the 1st on the left, and were to carry out the first phase of the attack, as far as the line Fontaine Notre Dame-W. of Haynecourt-Sauchy L'Estrée. Up to this line four successive objectives were assigned; from there onwards the second phase of the advance was to carry the assailants to the line of the Scheldt canal and the Sensée. During the pause between these two phases the 3rd Canadian Div. was to come in on the right of the 4th, and the 11th British Div. on the left of the 1st, so that the second phase would be carried out by the 3rd, 4th and 1st Canadian and 11th British Div. in that order from the south.

Punctually at the appointed time, at dawn on Sept. 27, the assault was delivered. The crossing of the narrow defile over the

canal between Inchy and Moeuvres was carried out according to programme, thanks in large measure to the intensity of the barrage covering the operation. All the field artillery of the Canadian and XVII. Corps were firing on this area, and as a frontage of only 9 yd. was allotted to each gun the resistance of the enemy was speedily stifled. While the infantry pressed forward to carry the Marquion line bridges were swiftly thrown over the dry canal bed, and batteries went over at a gallop to take up their positions for supporting the farther advance. The first objective and part of the second were carried on time and without great difficulty, but the left of the 1st Canadian Div., swinging to the left against Marquion, was checked for a time, until reinforcements, including units of the 11th Div., came up to complete the capture of the village and its defences. The second objective was in Allied hands by midday everywhere. Further progress was difficult, particularly on the right, where the 4th Canadian Div., which had outstripped the advance of the left of the Third Army, was held up by flanking fire and counter-attacks from the S., and was unable to do more than establish itself on the fourth objective by the evening, with its right thrown back along the Bapaume-Cambrai road. On this line it was relieved during the night by the 3rd Canadian Div. Farther to the N., the first phase of the attack was successfully completed by 2 P.M., and it was found possible to commence the second phase at 3.20 P.M.

At this hour the 1st Canadian and 11th Div. moved forward. The former stormed Haynecourt, pressed up to and beyond the Douai-Cambrai road E. of that village, and maintained its position despite repeated and violent hostile efforts to regain the lost ground. The 11th Div. also met with great success, and before nightfall was in possession of Sauchy Cauchy, Sauchy L'Estrée, Oisy and Epinoy.

The line therefore at the end of the day ran from just W. of Fontaine Notre Dame to the Douai-Cambrai road N.E. of Haynecourt, thence to Epinoy and Oisy le Verger. Four thousand prisoners and 100 guns had been taken in this day's advance of some 7,000 yd. in depth on a front of 15,000. The whole operation, investing as it did a most complicated and yet perfect combined action, had been a most brilliant success.

It was decided that the attack should be continued on the 28th, the 3rd and 4th Canadian Div. on the right and the 11th Div. on the left advancing at 6 A.M., while the 1st Canadian Div., which was farther advanced than they, followed suit only at 8 A.M. The Germans resisted stoutly all along the line, but were unable to stem the drive. On the right the 3rd Div. cleared Fontaine Notre Dame and the 4th Saille and were then held up for the time being in front of the Marcoing line, which, however, was completely cleared later in the evening by a renewed attack. The 1st Div. made little headway, but the 11th Div. got well forward along its front and established itself from Epinoy to Aubencheul on the Sensée. Large captures were made besides the substantial gain of ground.

At the same hour on the 29th the infantry again went forward, the objectives being to complete the capture of the Marcoing line and the seizure of the Scheldt canal bridges W. and N. of Cambrai. The 11th Div. made no progress, but the line on the rest of the front was advanced to the junction of the roads from Arras and Bapaume in the suburbs of Cambrai and the line of the Douai-Cambrai road and railway, including the village of Sancourt. A certain amount of ground gained beyond the railway had to be evacuated before the violent counter-blows of the enemy against the left of the 1st and then of the 4th Div.

None the less neither side was prepared to give up the struggle. At dawn next day the 3rd and 4th Canadian Div. advanced once more with the object of securing the coveted bridges over the Scheldt canal, to be followed later by the 1st Canadian and 11th Div., which were to clear the peninsula between that canal and the Sensée. A certain amount of progress was made, the village of Tilloy being entered by the 3rd Div. and Blécourt by the 4th Div., but not all these gains could be maintained in face of repeated hostile counter-attacks, and at the end of the day the line ran much as before on the front of these two divisions. The sec-

ond phase of the offensive as planned could not even be commenced. Another effort was made on the morrow to complete the operation. It met with stubborn resistance from German divisions in line, now increased to ten. These endeavoured again and again to check the Canadian advance by blows against their left front and left from the direction of the confluence of the Sensée and the Scheldt canal. The Canadian advance began at 5 A.M. and went well despite all obstacles. The 3rd and 4th Div. attained their objectives—the line of the canal south of Ramillies and the road between that place and Cuvillers. The 1st Div. had even more desperate fighting before it succeeded in clearing Blécourt, Cuvillers and Bantigny, and when it had finally captured them a powerful thrust against its exposed left from the direction of Paillencourt forced back the Canadian line to the west of Cuvillers and Bantigny. Meanwhile the 11th Div. on the N., attacking in the afternoon, secured and held its objectives and thus eased the situation on that flank. On the evening of Oct. 1 the Canadian line ran from the western suburbs of Cambrai by Tilloy to the Douai-Cambrai railway W. of Blécourt and along that railway to the Sensée.

This was the final day of the Cambrai battle on the First Army front. After its exertions and achievements during the previous five days of incessant fighting the Canadian Corps was in urgent need of rest and retraining. It was therefore decided to postpone further attacks for a few days, until the effect of the Third and Fourth Armies' advance in the S. should make itself felt. The results of the First Army's battle were in any case satisfactory to a degree.

Though Cambrai itself only fell into Allied hands a week later, its fate was in fact sealed by the five days' fighting which has just been narrated. During its course the First Army's line had been advanced close on eight miles; its four divisions had driven back the 13 German divisions engaged by the Seventeenth Army on their front, and taken from them over 7,000 prisoners, 205 guns and 950 machine-guns, besides inflicting losses in killed and wounded which certainly far outweighed their own casualties. The last German fortified system had been breached on this front and the first stage—and the most difficult stage—completed of that triumphant advance which was to lead the First Army, in six weeks' time, back to Mons.

6. *Assault of Third Army on Hindenburg Line (Sept. 27-Oct. 2).* The front of the Third Army on the evening of Sept. 26 ran W. of Villers Guislain and Gouzeaucourt, E. of Trescault and Havrincourt to the line of the Canal du Nord S. of Moeuvres and along its W. bank to that village. From right to left along this front were the V. Corps (33rd, 21st and 38th Div. in line), the IV. Corps (5th and 42nd Div. in line, New Zealand Div. in support), the VI. Corps (3rd and Guards Div. in front, 62nd in support) and the XVII. Corps (52nd and 63rd Div. in front, 57th in support). Facing them the German Seventeenth Army held the Hindenburg system with seven divisions in front line.

In view of the great strength of the defences in the southern section of the Third Army zone it was decided that there should at first be no attack by the V. Corps, but that the salient held by the enemy in that area should be left until the progress of the operations on either flank should endanger the garrison's line of retreat. Accordingly the offensive of Sept. 27 was carried out by the Third Army with its three leftmost corps only.

The task of the IV. and VI. Corps was to clear the Hindenburg front and support lines on either side of the Ribécourt valley as far E. as Highland Ridge (running N. from Villers Plouich) and the spur overlooking Marcoing from the west. Five objectives were laid down, and exploitation was to be carried out beyond the final one to Welsh Ridge (N. of La Vacquerie) and the Scheldt canal. The XVII. Corps was first to carry the Hindenburg system on its front and then to advance to the line Graincourt-Anneux, with exploitation if possible as far as Cantaing-Fontaine Notre Dame. Zero hour was at 5:20 A.M.

The 5th Div. of the IV. Corps moving off at that hour early met stubborn resistance and suffered from flanking fire from the south. Beaucamp was not taken till 11:30 A.M. after hard fighting, and then had to be surrendered again late in the evening to a

heavy counter-attack. In consequence the right wing of the 42nd Div. was somewhat checked in its advance, and whereas the left of that division, starting off at 7:52 A.M., was well beyond its third objective by midday the right wing had only just completed the first stage of its advance. By 2:30 P.M. the left of the 42nd in conjunction with the right of the 4th Div. (VI. Corps) had captured Ribécourt, but the final stages of the advance had to be postponed till next morning.

The VI. Corps met with more success. The 3rd Div., overrunning the hostile defences with little difficulty, shortly after midday seized Flesquières and Ribécourt and established itself east of these villages, where the 62nd Div. passed through to continue the advance and carried the line to the outskirts of Marcoing, thus attaining all the corps' objectives for the day. On the left the Guards, despite heavy losses from flanking fire against their left, owing to the fact that the XVII. Corps was unable to keep up with their rapid progress, pressed forward between Flesquières and Graincourt and reached the neighbourhood of Prémey chapel (N.W. of Marcoing). They were relieved by the 2nd Div. on that evening.

The XVII. Corps had first to clear the W. bank of the Canal du Nord W. of Graincourt before it could attempt to pass it and get forward to its day's objectives. The right division, the 52nd, successfully carried out this operation with a portion of its forces, while other units crossed the canal on the right in conjunction with the 63rd Div., and met with severe resistance. It was not till late in the afternoon that Annex and Graincourt fell into Allied hands and the 57th Div. passed into first line for the further advance on Cantaing, which proved to be impracticable before nightfall.

On the night of Sept. 27, then, the Third Army front ran from W. of Beaucamp by Ribécourt, Prémey chapel and Annex to W. of Fontaine Notre Dame, where it connected with the right of the Canadian Corps—a maximum penetration of some 3½ m. from the jumping-off line. Operations were resumed next day. The IV. Corps began its attack at 2:30 A.M. under cover of darkness; Beaucamp was once more secured, Highland Ridge was carried by storm, and parties pushed forward to Welsh Ridge which was cleared of the enemy by 6 P.M. The VI. Corps, attacking with the 62nd and 2nd Div. as soon as it was light enough to see, cleared the Germans from the W. bank of the Scheldt canal and established itself on the line Marcoing-Noyelles; it was found impossible, however, to get over the canal at the moment. The line of the canal was also reached on the XVII. Corps' front, E. of Cantaing, and her parties succeeded in getting over the obstacle and establishing themselves there despite the counter-attacks of the enemy.

September 29 saw the V. Corps on the Army right joining in the attack in conjunction with the Fourth Army to the south. Little progress was made in this sector, but on all the rest of the front considerable results were achieved. The IV. Corps, advancing with the 5th Div. on the right and the New Zealanders on the left, carried Gonnelleu and Banteux in the right section, securing a bridge-head at Crèvecoeur in the left section of its zone of attack. The VI. Corps to its left had passed the canal in force before the end of the day and established itself to the E. of Masnières; the XVII. Corps also got the 63rd Div. over the obstacle, while the 57th Div. on the left cleared the Marcoing line between the canal and the Bspaume-Cambrai road and pushed on to the outskirts of the city itself.

On Sept. 30 and Oct. 1 the advance was continued, but more slowly and with greater difficulty. The Germans, menaced on either flank, as had been foreseen, withdrew from their salient on the V. Corps' front, and the latter were able to get forward to the canal line and commence preparations for forcing it. The IV. Corps secured its footing on the E. bank about Crèvecoeur, while the VI. Corps occupied Rumilly after two attempts, and the XVII. Corps on the left flank reached the suburbs of Cambrai on both banks of the Scheldt canal.

The battle on the Third Army front was now over. The Hindenburg line had been breached on a front of nine miles, and an average advance of seven miles effected in the face of the most

formidable obstacles, both natural and artificial. Thirteen German divisions had been forced to give ground before 12 British, and had left behind them many prisoners and guns during the five days' fighting. The fate of Cambrai was sealed and only a part of the incompletely constructed Masnières-Beaurevoir line, already broken in its northern sector by the Third Army and in its southern sector by the Fourth Army, was left as a dyke to stem the further British advance. That line, as the attack of Oct. 8 was to show, was destined to prove quite insufficient to hold up those troops who had stormed the immensely powerful defences of the Hindenburg system.

7. *Storming of Hindenburg Line by Fourth Army (Sept. 27—Oct. 5).*—The forces at the disposal of the Fourth Army for the attack of the formidable defences of the Hindenburg line on the front of 12 m. from Selency to Vendhuile consisted of the IX. Corps (Braithwaite) (1st and 46th Div. in line, 32nd in support); the composite American-Australian Corps (Monash) (27th and 30th U.S. Div. in line, 5th and 3rd Australian in support, and Australian in reserve); and the III. Corps (Butler) (12th and 58th Div. in line, 18th in support). The IX. Corps' zone of attack included the Canal du Nord and the defences on either side of Bellenglise, while that of the composite corps was the canal tunnel on either side of Bellicourt. The III. Corps had the subsidiary rôle of covering and securing the left flank of the composite corps. The first objective assigned to be captured by the divisions in line included the Hindenburg system on both banks of the canal and the Hindenburg reserve line a mile to the E.; once these had been secured the supporting divisions were to pass through and carry the last line of defence, the Masnières-Beaurevoir line, between the latter village and Le Tronquoy.

The German Second Army, facing the Fourth Army, consisted at this time of the LIV., IV. Reserve and LI. Corps in line, and the XI. Corps in reserve. The III. Corps on the right of the German Eighteenth Army was also partly on the Allied front. Ninety-eight divisions were in line and others in support, but neither physically nor morally were these troops all that could be desired. Moreover, though they must have been well aware that an attack was coming, the date and time were unknown and remained unknown till the moment of the assault.

The preliminary bombardment commenced at 10 P.M. on Sept. 26 and went on for 56 hours; about 1,600 guns of all calibres took part in it, yet so formidable were the hostile defences that the task of the infantry still remained one of great difficulty. This was enhanced by the fact that only in certain sectors where the canal passed under the Bellicourt tunnel was it possible to employ tanks, of which some 130 were allotted to the left of the IX. Corps and to the Composite Corps.

Nevertheless, when the infantry broke forward to the attack at 5:55 A.M. on Sept. 29 under cover of the morning mist their advance made rapid progress.

On the IX. Corps front, while the 6th Div. on the right secured the army flank about Gricourt, the 46th Div. overran all obstacles in its front, swam or crossed the canal, stormed Bellenglise village and the defences beyond, and by 3 P.M. was in possession of its objectives everywhere. At the cost of only 800 casualties it had penetrated some 3½ m. deep into the most formidable part of the hostile fortress, routed the four enemy divisions in its front and taken 4,200 prisoners and 70 guns. It was perhaps the most astonishing single feat of arms in the World War. The 32nd Div. passing through found its task much simplified, and before nightfall had carried the Hindenburg reserve line on practically the whole of its front, taking a further 800 men and 20 guns in its advance.

Farther to the left, however, matters had gone less well on the front of the composite Australian-American Corps. Gallantry and inexperience induced the U.S. Div. in the front line, handicapped from the start owing to confusion in the preliminary assembly of their units, to push too far forward without making sure of the ground in their rear. The supporting Australian divisions therefore found themselves in a difficult situation, which was only redeemed by hard and skilful infantry fighting. On the right of the corps sector the 5th Australian Div. finally

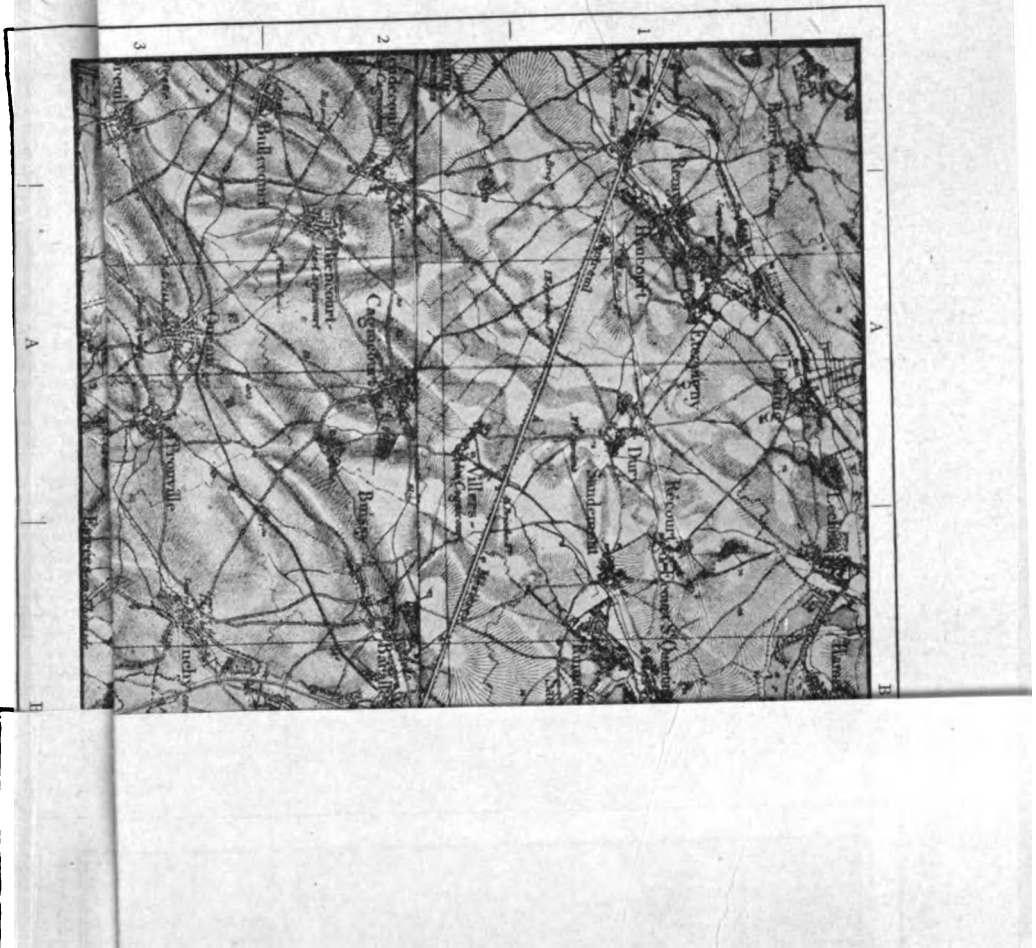





got as far forward as the Hindenburg reserve line about Nauroy; but the 3rd Australian Div. on the left could make little headway from its starting line, and the hostile defences about Bony remained intact.

On the left flank of the army the III. Corps was able to fulfil satisfactorily the subsidiary rôle assigned to it.

Despite the comparative failure of the Composite Corps the attack had on the whole been a brilliant success, seven Allied divisions having defeated nine enemy divisions ensconced in immensely powerful works, capturing from them 5,300 prisoners and 100 guns and effecting such a wide breach in the last German line of defence that its complete capture in a few days was assured.

Gen. Rawlinson decided that the offensive should be continued on the 30th, the U.S. Div. being withdrawn from line for the present. The IX. Corps was to round off its success on the right by clearing the Thorigny area on the near bank of the canal, and occupying the ground on its front as far as the Masières-Beauvevoir line; the Australians were to secure the remainder of the first day's objectives in its sector between Bellicourt and Vendhuile, while the III. Corps would occupy the latter village to cover their left. The IX. and III. Corps were able to carry out this programme without serious difficulty; but the Australians again met with stubborn resistance, and at the end of the day, though their right division, the 5th, had cleared the greater part of the Hindenburg reserve line, the 3rd Div., on the left, working up the Hindenburg line from the S., had been able to get no farther than S. of Bony. The completion of the operation therefore was deferred till Oct. 1, when the 3rd Australian Div., after fighting all night, succeeded by a combined attack from W. and S. in clearing the Hindenburg line entirely and pushing forward to the edge of Le Catelet. The IX. Corps also had a successful day; the 32nd Div., advancing in conjunction with the 5th Australian Div., cleared Joncourt and Estrées and breached the Masières-Beauvevoir line on a mile front E. of the former village. This hold was maintained all next day, despite desperate hostile efforts to recover the lost ground; two British attacks on Sequehart were, however, repulsed.

During the first two days of Oct. the army front was redistributed in preparation for the general offensive to be undertaken on the 3rd against the last defensive position left to the enemy—the Masières-Beauvevoir line. On the evening of the 2nd the line was held by the IX. Corps on the right, with all three divisions, 1st, 32nd and 46th, in front line; the Australian Corps with the 2nd Australian Div. in front line; and the XIII. Corps, with the 50th Div. in line, and the 25th and 66th in support. The orders were for the IX. Corps to take Sequehart and Ramicourt and push forward to Montbréhain; for the Australians to occupy the line from W. of Ramicourt to S.W. of Beauvevoir and then to seize the latter place and Ponceaux; and for the XIII. Corps to clear Gouy and Le Catelet.

Zero hour was at 6:5 A.M. on the 3rd. The IX. Corps on the right had heavy fighting, and after attaining their final objectives about 10:30 A.M. were counter-attacked repeatedly and forced to relinquish Montbréhain and some of the ground gained to the south. The Australian Corps also successfully attained its first objectives, though not till later in the evening, so that the exploitation of their success on this day proved out of the question. The main object of the day's attack had, however, been completely achieved, for along all the front of these two corps the Masières-Beauvevoir line was in Allied hands. The XIII. Corps on the left established itself in Gouy and Le Catelet by midday, and though a strong hostile counter-attack recovered the former village for a time the ground lost was regained before the nightfall.

After a redistribution of the front the operations were resumed on the 4th. The main task fell to the XIII. Corps, but little progress was made in that sector, as the enemy, who was believed to be preparing for a withdrawal eastwards, resisted stubbornly around Beauvevoir to cover his retirement. The Australian and IX. Corps also had little result to show for their efforts. Oct. 5th, however, saw the successful completion of the

programme, the XIII. Corps taking possession of Beauvevoir with the 25th Div. and pushing the 50th Div. on its left wing well north of Gouy towards Aubeneuil in conjunction with the right of the Third Army, while the Australians secured Montbréhain. It was to be their last feat of arms in the World War, and they had the satisfaction of knowing, as they left the line on the 6th, that the last fortifications of the Germans on the Fourth Army front had fallen, and that the way was clear into the open country beyond.

During the period between Sept. 20 and Oct. 5 the Fourth Army's 12 divisions had completely defeated 20 enemy divisions, driving them from a succession of defensive lines of unexampled strength and taking from them close on 15,000 prisoners and 120 guns, and could claim for themselves with justice a preponderating share in the decisive victory of the war.

8. *Results of the Battle.*—The results of the battle may be thus summed up: 35 British divisions had been engaged against 79 German divisions. The latter had been forced to retreat some 20 m. on a front of 30, and had lost 67,000 prisoners, 680 guns and vast quantities of other material, besides their killed and wounded. The formidable defensive system on which the German Higher Command, apparently with good reasons, relied to hold up the Allied advance until the winter should give pause to active operations and secure for their hard-driven troops and weary people a little respite from their trials and disillusionments, had been burst into fragments, and there was left for German arms no further resource for staving off disaster.

CAMBRIDGE, England (see 5.90).—The architectural amenities of the town, as distinct from the university, were increased by the County Hall in Hobson Street (1913), a Wesleyan church at the corner of King Street and Short Street (1913), and a handsome gate-house to the Leys school (1914). A national plant-breeding institute was in course of completion on the Huntingdon Road in 1921.

*The University.*—In spite of the incidence of the World War, the period 1910 to 1921, viewed as a whole, must rank as one of great activity in the history of Cambridge University. On constitutional proposals of more than ordinary moment, such as those of conferring greater legislative power on resident university and college teachers with the partial disfranchisement of the Senate and the electoral roll (1910 and 1920) or the admission of women to all academic privileges (1920), the university maintained a conservative attitude, but in matters secondary only to these in importance it followed a policy of continuous and thorough-going reform. The courses of study for honours and, more especially, for pass men underwent considerable revision. After prolonged deliberations, Greek, as a compulsory subject, was dropped from, and other noteworthy changes were effected in, the Previous Examination (1919); the regulations governing the pass degree were entirely remodelled (1920); several of the honours examinations, notably the classical tripos and the oriental languages tripos, were reconstituted with a division into two parts, the first of which does not normally carry the B.A. degree with it. New triposes were established in anthropology (1913) and geography (1919), while the mediaeval and modern languages tripos, greatly enlarged in scope, was split into the modern and mediaeval languages tripos and the English tripos (1917). The university further recognized the value of graduate studies by establishing the degrees of Ph.D. (1919), and of M.Litt. and M.Sc. (1920). A series of enactments (1912-4) made several changes in the mode of procedure to the degree of D.D. and threw it open to others than those in Holy Orders of the Church of England.

The increasing diversity of studies resulted also in the establishment of new professorships, readerships and boards of studies: professorships of English Literature (1910), Genetics (1912), Biochemistry (1914), Italian (1919), Naval History (1919), French (1919), Physics (1919), Aeronautical Engineering (1919), and Physical Chemistry (1920); readerships in Spanish, Modern History, Geography, Agriculture, Agricultural Physiology, Physiology, Morphology of Vertebrates, Petrology, Pharmacology, Electrical Meteorology and Estate Management; Special Boards for Architectural Studies (1912) and Psychological Studies (1920). Trinity College offered in 1921 to establish a prelectorship in Geodesy.

Aids to learning and research of a more material nature were provided by the erection and augmentation of numerous institutes. The engineering laboratory on the north side of Downing Street was twice enlarged and finally removed to a completely new site behind Scoopie Terrace, Trumpington Road (1920-1). Part of the buildings thereby vacated, as well as new ones erected close to them, were taken over by the neighbouring chemical laboratories. On the south side of Downing Street sites were found for the school of agriculture (1910), the Museum of Archaeology and Ethnology (1910-5), the psychological laboratory (1913), the physiological laboratory (1914), the forestry school (1914), the Molteno Institute of Animal Parasitology (1921) and a low temperature station for research in biochemistry and biophysics (not completed in 1921). The Arts school, off Bene't Street, a fine brick building faced with stone, designed by G. Hubbard, which contains a number of lecture rooms and also houses several departmental libraries, was opened in 1911. In that year the university accepted the Government's proposal to take charge of the solar physics observatory, then at South Kensington, and the necessary accommodation, in close proximity to the existing observatory on the Madingley Road, was completed in 1913. Field laboratories in connexion with the agricultural department, situated on the Milton Road, came into use in 1910-1.

Emmanuel College and Queens' College, to the north of their older buildings in either case, added to their fabric; Cheshunt College found permanent quarters at the west end of Bateman Street (1915), and the chapels of Sidney Sussex and Corpus Christi College were enlarged and redecorated.

*Effects of the War.*—The immediate effect of the World War on Cambridge University (16,000 alumni of which were engaged on active service) was enormously to reduce the numbers of teachers and students. (There were 3,263 undergraduates in the Michaelmas term of 1913, 1,658 in Michaelmas term 1914, 398 in Michaelmas term 1917.) The place of those who had gone was, spatially, taken by professors and students from the Belgian universities, by Serbian school-boys and students, by nurses attached to the First Eastern General Hospital (T), first set up in Neville's Court, Trinity College, in Aug. 1914, and then (1914-9) on the cricket-field of King's and Clare, and, most effectively, by cadet battalions and officers attending staff courses. The absorption of many university teachers by Government departments and the first-hand acquaintance with academic training gained by a still larger number of servants of the Crown greatly advanced the cooperation between university and State, which had already begun practically with Government grants to the schools of agriculture and forestry and to the various departments concerned with the instruction of medical students (1914). The cessation of hostilities did not effect any weakening of this tie: the Admiralty, the Air Ministry and the War Office (on behalf of the Royal Engineers and Signal Corps) organized temporary and permanent training schemes in Cambridge for officers, to afford them immediate acquaintance with the latest developments in the science of their respective callings. When the university, confronted with a serious decline in the value of money and an abnormal number of students (4,363 undergraduates in Michaelmas term 1919, 4,883 in Michaelmas term 1920), was left with the unpleasant alternatives of a serious financial deficit or an equally serious diminution of its educational efficacy, the Government accorded it (1919), as a kind of off-set to the indebtedness it had incurred, a temporary annual grant of £30,000, pending the report of the Royal Commission which had been appointed. (B. W. D.)

**CAMERON, JAMES DONALD** (1833-1918), American politician (see 5.109), died at his country home, Lancaster co., Pa., Aug. 30 1918.

**CAMEROON** (Fr. *Cameroun*, Ger. *Kamerun*; see 5.110). By the Franco-German agreement of Nov. 4 1911 some 107,200 sq. m. of French Equatorial Africa were added to the German protectorate, while 6,450 sq. m. of Cameroon in the Lake Chad region were ceded to France. An Anglo-German agreement of March 11 1913 settled the frontier of Nigeria and Cameroon between Yola and the Cross river. By the agreement with France the area of Cameroon was increased from about 191,000 sq. m. to 292,000 sq. m. and the pop. from some 2,600,000 to about 3,300,000. In 1913 the white inhabitants numbered 1,871, of whom 1,643 were German.

The additions to Cameroon were "compensation" to Germany for the assumption by France of a protectorate over Morocco (see AFRICA, *History*). They included two tongues of land running S.E. from the main bulk of the protectorate, one along the valley of the Sanga to its junction with the Congo, the other reaching the Ubangi. Cameroon thus obtained contact with Belgian Congo and full access to the navigable waters of the Congo basin, while the French colony of Middle Congo was cut into fragments. The transfer of territory took place in 1912 and

the Germans established military and trading posts both on the Congo and Ubangi. There had been, however, insufficient time to develop the newly acquired territories before the World War put an end to German sovereignty.

Progress was made during 1907-13 in the development of the economic resources of the country, which consisted principally of palm kernels and palm oil, rubber, cocoa, ivory, timber and live stock. Forests cover some 50,000 sq. m. of the country and over 60% of the wood is of commercial value. The plantations of cocoa and rubber largely increased and a beginning was made in coffee-growing. The value of trade, imports and exports, was about £3,000,000 in 1913, compared with £1,700,000 in 1907. Revenue continued to be below the cost of administration, the figures for 1913-4 being: revenue £565,000, expenditure £863,000. Deficits were made good by grants from the German treasury. Some progress was made in railway construction, two main lines being undertaken. The first started from Duala, in the Cameroon estuary and the principal port, and went S.E. by Edea towards the central plateau; the second started from Bonaberi, on the Cameroon estuary opposite Duala, and, skirting Mt. Cameroon, was designed to go N.E. towards Lake Chad. In 1913 a direct cable from Duala to Germany was opened and in 1914 wireless telegraphic stations were erected.

Under Dr. T. Seitz's governorship (1907-10) the administration endeavoured to remedy the worst abuses in native affairs, and revolts became less frequent. The Moslem Fula chiefs in the northern region were patronized and comparatively little interfered with, slavery being continued. Dr. Seitz, on his transference to South-West Africa, was succeeded by Dr. Gleim, who in 1912 gave place to Herr Ebermeier, the last German governor. He was assisted by a council on which sat three nominated representative merchants. The seat of Government was at Buëa, on the slope of Mt. Cameroon.

Cameroon was invaded in Sept. 1914 by British and French (native) troops under the command of Maj.-Gen. Dobell supported by H.M. SS. "Cumberland," "Challenger" and "Dwarf" under the command of Capt. Cyril Fuller, R.N. Duala was shelled and thereupon evacuated, and the last German garrison surrendered in Feb. 1916.

After the conquest of the protectorate the country was provisionally divided into areas administered respectively by French and British authorities. At first the British administered the Duala region, but it and the whole estuary of the Cameroon river was subsequently transferred to French control, the British retaining charge of the port of Victoria, the hill-station at Buëa, and a strip of territory averaging 70 to 80 m. in width from W. to E. flanking the E. boundary of Nigeria. The Supreme Council, sitting in Paris on May 7 1919, gave the mandate for Cameroon to France and Great Britain. By an agreement between those Powers concluded on July 4 1919 Britain finally retained the strip of ex-German territory bordering Nigeria. This British strip included in the south Mt. Cameroon and in the north Dikoa and the adjacent parts of "German" Bornu. The rest of Cameroon, 166,500 sq. m. out of the 191,000 sq. m. of the protectorate as constituted in 1910, fell to France. Those districts which the French had been compelled to cede to Germany in 1911 were reincorporated in French Equatorial Africa and formed no part of the mandated territory. In the mandated area no discrimination in respect to trade could be made in favour of French citizens as against nationals of other states, members of the League of Nations.

During 1920 a provisional boundary was determined by British and French officers who met at various points and this was to remain in force until a commission could be entrusted with the final work of demarcation.

The southern portion of the British area was constituted a province of Nigeria under the administration of a senior resident. The remainder of the territory is incorporated for administrative purposes in the provinces of Muri, Yola and Bornu, to which portions of it adjoin; but in every instance the accounts of the occupied area are kept separate from those of Nigeria in order that detailed accounts showing the revenue collected and the expenditure incurred can at any moment be produced.

Politically the most important additions to territory under British rule are the Emirate of Dikoa, which has been reunited to

Bornu (with which it is closely connected) and a number of small emirates in the neighbourhood of Yola, which are similarly reunited to the emirate of that name. Farther south, the districts of Oseidinge, Tinto and Bamenda, which form parts of the Cameroon Province, are very little developed, but traces are being made for roads designed to connect them more closely with the neighbouring districts of Nigeria. Buea, which has an altitude of some 4,000 ft., though it enjoys an almost perfect climate for some four months of the year, has an excessive rainfall and the humidity resulting therefrom renders it of little value as a permanent hill-station. It is connected with Victoria by a light railway which was built to serve the extensive cocoa and rubber plantations opened and developed by a number of German companies in its vicinity and in the country lying between the foot-hills of the Cameroon mountains and the sea. After the expulsion of the Germans in 1915 these plantations were kept up and managed by officers employed for the purpose by the Government of Nigeria; and it was intended that as soon as a convenient opportunity offered they should be disposed of by auction, the proceeds being credited to the reparations account. At Victoria the Germans had established a small but very beautiful and valuable botanical garden which the Government of Nigeria is taking steps to maintain.

With the exception of the area covered by the plantations, the sphere occupied by the British in the Cameroons is very little developed. Internal means of communication are of the most primitive description; sea communications with Calabar are irregular; the population is not large; and the administration of the area imposes an annually recurring charge upon the Government of Nigeria. In 1921 this amounted to 167,000. It was believed that the mandate for this territory would be issued in 1922.

During 1919-20 the French, who retained the name of Cameroon (in its French form), organized a regular administration. The mandated area was given financial and administrative autonomy, but to ensure unity of policy in common interests the commissioner of Cameroon had the right to a seat on the council of the governor-general of French Equatorial Africa. Cameroon was divided into 12 circoscriptions with Duala (pop. about 18,000) as capital. In May 1921 the capital was transferred to Yaunde—a town of 30,000 inhabitants, occupying a comparatively healthy and central position on the central plateau, and 110 m. S.S.E. of Duala. A route for the extension of the railway from Duala to Yaunde was surveyed. In 1920 railhead was at Esaka, some 45 m. short of Yaunde. The revival of trade after the World War was slow; but in 1920 the combined value of imports and exports was roughly estimated at over £2,000,000.

See I. von Puttkamer, *Gouverneurjahre* (1915); E. Zimmermann, *Neukamerun* (1913); L. Hause, *Durchs unbekante Kamerun* (1915); A. F. Calvert, *The Cameroons* (1917); G. Bruel, *L'Afrique Equatoriale Française* (1918). A good general map on the scale of 1/2,000,000 was issued by the French colonial ministry in 1920. (F. R. C.)

THE CAMPAIGN OF 1914-8.—On the opening of the World War, Cameroon was invaded independently by such troops—few in number—as the British in Nigeria and the French in Equatorial Africa had at their disposal. The German protectorate was roughly triangular in shape, with its base extending from the estuary of the Muni E. to the valley of the Sangha and its apex reaching Lake Chad; with, in the S.E., two tongues of land running to the Congo and Ubangi rivers respectively. It enclosed on the S.W. Spanish Guinea, Nigeria lay on its N.W., elsewhere it was bordered by French territory. The centre and S. of the country are mostly covered with forest or dense bush; in the E. there is much savannah-like land; the northern part is generally clear of bush, but (save in the immediate neighbourhood of Lake Chad), broken and open, mountainous and with many hill-posts, affording excellent means of defence. The German forces were scattered, but the greater part were about Duala, in the Cameroon estuary, and the chief port.

According to German official statistics the military force in Cameroon in 1913 consisted of 199 Germans and 1,550 natives, and the police force numbering 40 Germans and 1,255 natives. When hostilities began some hundreds of German settlers were enlisted, together with a number of sailors belonging to ships which took refuge in the Cameroon estuary. Considerable numbers of natives were also trained as askaris, and in the N. one or two Fula chiefs, with their levies, aided the Germans. Col. Zimmermann, an able and resolute soldier, was in command. The Germans endeavoured, with scant success, to provoke a *jihad* among the Moslem tribes in northern Cameroon. In general and especially in the coast districts the natives proved hostile to the Germans. As early as Aug. 8 1914 the Germans had taken two members of the principal native family of Duala for ransom.

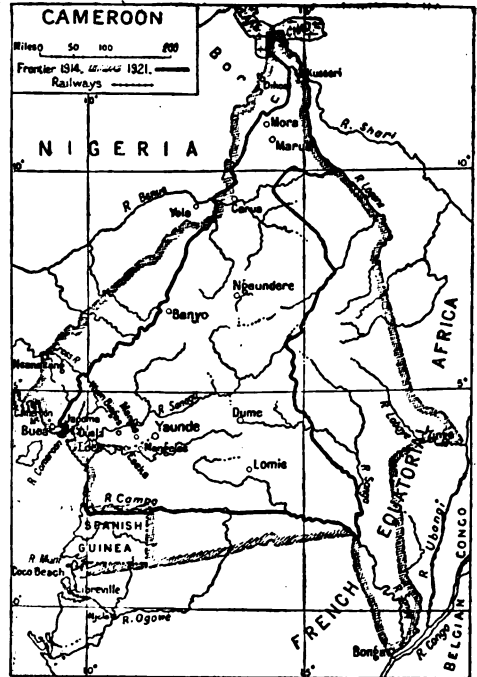

Hostilities opened on Aug. 6 1914, when a small French force captured Bonga, at the Sangha-Congo confluence. The next day Zinga, on the Ubangi, was captured. This prompt action anticipated and prevented an offensive planned by the Germans. The operations were directed by Gen. Amyrich, commander-in-chief in French Equatorial Africa. That officer next formed two columns: one under Col. Hutin advanced N. up the Sangha valley, the other under Col. Morrison advanced W. along the Lobaye, which joins the Ubangi near Zinga. Both columns were at first successful; their objectives were Lomie and Dume respectively, posts in the centre of Cameroon. Almost simultaneously with the opening of Gen. Amyrich's campaign in the S.E., Gen. Largaue<sup>1</sup> in the far N. unsuccessfully attacked the post of Kuseri on the Logone river (Lake Chad region). A second attack, on Sept. 21, was successful. Meantime a British column from Nigeria under Capt. R. W. Fox had crossed the frontier (Aug. 25) and had attacked but failed to capture the hill-fort of Mora which was held by Capt. von Raben. Largaue now sent a French column under Col. Brisset to cooperate with Capt. Fox. On Dec. 12 Brisset occupied Marua, a town S. of Mora, and by that date the whole of the Lake Chad region of Cameroon had been cleared of the Germans except the fort of Mora, where the situation remained unchanged to the close of the campaign. For the most part the British were content to blockade the place, though between Aug. 23 and Sept. 15 1915 unsuccessful attempts were made to storm it. Mora had the advantage of a good water supply.

On the same day (Aug. 25 1914) on which Capt. Fox invaded northern Cameroon, two other British columns<sup>2</sup> invaded Cameroon. One, starting from Yola, attempted to capture Garua (Aug. 30), failed, suffered heavily and was compelled to fall back on Yola. Among the killed was the commander, Lt.-Col. P. Maclear. Reorganized and placed under command of Lt.-Col. Webb Bowen, the Yola column later in the year cooperated with Col. Brisset. The other column, which entered Cameroon in the Cross river district, suffered a severe reverse at Nsanakang on Sept. 6, being surprised by a German force brought from Duala and sustaining 168 casual-

<sup>1</sup> Gen. Largaue (1869-1916) had been a member of the Marchand Expedition to Fashoda and later took a leading part in the conquest and exploration of the central Sudan. It was as commander of the French forces in the Lake Chad region that he directed the French operations in northern Cameroon, later giving Gen. Cunliffe loyal support. In Oct. 1915 he returned to France. He was killed in command of a brigade at Verdun March 26 1916.

<sup>2</sup> The operations on this side were under the direction of Col. Sir F. D. Lugard, governor of Nigeria.

ties. All the Nigerian forces were native troops (under British officers), being drawn from the Nigerian Regt. of the West African Frontier Force. Sir F. D. Lugard had contemplated operations on a larger scale than those carried out, but was called upon to supply contingents for an Anglo-French Expeditionary Force, which it had been decided should be dispatched.

The decision to send an expeditionary force was reached by the British and French military authorities in the first month of the war, and Maj.-Gen. Sir Charles M. Dobell, inspector-general of the W.A.F.F., was chosen for the command. His force, which at the outset numbered 4,300, was composed, in almost equal proportions, of British and French negro troops. The French contingent under Col. Mayer embarked mainly at Dakar, the British at Freetown (Sierra Leone) and other ports, and the expedition sailed for Duala about the middle of September. The many creeks along the coast had already been patrolled by light craft and the Nigeria Marine, while the gunboat "Dwarf" and other boats had anchored off the estuary of the Cameroon. The Germans had mined the estuary and had blocked the fairway. On the arrival of Dobell's transports, escorted by the cruisers "Cumberland," "Challenger" and other vessels, including the French cruiser "Bruix," a passage was forced through the barrier and on Sept. 25 Gen. Dobell summoned the commandant to surrender. On his refusal Duala was bombarded on Sept. 26 and surrendered the next day. Over 400 Germans were found in the port and 30,915 tons of shipping were captured.

Col. Zimmermann had been at Duala from Aug. 4; having decided to conduct the defence of the protectorate from a central position, on the day Duala was bombarded he withdrew by train to Edea, 40 m. to the south-east. The governor, Herr Ebermaier, was already at Edea; there appears to have been close cooperation throughout between the governor and the commander of the forces.

From the coast inland for 150 m. stretches the typical monotonous and almost impenetrable West African forest, fringed seaward by an area of mangrove swamp containing hundreds of creeks. An enemy in this forest could be only a few yards away and still be invisible. Fortunately for the Allies the natives were friendly.

Gen. Dobell at once organized three columns to pursue the enemy through the forest at Edea. One column ascended the Sanaga (not to be confused with the Sangha), and others marched overland. Col. Zimmermann had destroyed the railway in his retreat and at Japoma, where a bridge had spanned a creek 900 yd. wide, a German detachment had been posted. The bridge had been broken but the passage was forced by French infantry with the assistance of light-draught warships and British marines. Opposition to the advance continued the whole way but Edea was occupied on Oct. 26 (1914). But by that time Col. Zimmermann and Herr Ebermaier had retired another 100 m. E. to Yaunde, and the Allied columns were too weak to continue the pursuit. The force stationed at Edea consisted of French troops under Col. Mayer. Yaunde, which had become the German headquarters, was well chosen. It was on high tableland, beyond the bounds of the dense forest, and so situated that Col. Zimmermann could from it maintain communication with the German posts in the E. and N. of the protectorate.

While for lack of sufficient men Col. Mayer was compelled to remain inactive at Edea, Gen. Dobell proceeded to clear the region between the Cameroon estuary and Nigeria. Lt.-Col. A. H. Hayward had charge of the principal operations. By the end of 1914 the whole of the northern railway had been occupied, together with Bua, the administrative capital on the slopes of Mt. Cameroon.

Meantime practically no progress had been made by the British and French columns in northern Cameroon, while of Gen. Aymerich's columns advancing from the E. that under Col. Morrison had been checked and that under Col. Hutin was making headway. (Hutin, in Oct. 1914, had been joined by a small contingent of Belgian Congo troops, while the Congo administration placed their river steamers and artillery at the disposal of Gen. Aymerich.)

Thus, at the beginning of 1915 the Allied offensive had almost come to a standstill. The forces needed reorganization, coordination and strengthening, and this was now taken in hand. Brig.-Gen. F. H. Cunliffe was appointed to command the British and French troops in northern Cameroon, where the Germans were taking the offensive at various points, and instructed to prosecute the campaign with renewed vigour. Dobell called for reinforcements from the French and British West African colonies, and these were sent, the first fresh troops reaching Duala in Feb. (1915). The previous month (on Jan. 5) Col. Mayer had beaten off an attack made on his force at Edea, the Germans losing heavily in killed and wounded. This was the only offensive action taken by the forces under Col. Zimmermann's direct orders.

All the facts pointed clearly to the main lines of the Allied strategy in the future operations, namely a combined and concentric advance on Yaunde. Meanwhile, to prevent Col. Zimmermann, if he broke S. from Yaunde, from reaching the neutral Spanish territory, a small French column under Col. Miquelard, which had landed at Coco Beach, on the S. shore of the Mand estuary, was advancing along the eastern borders of Spanish Guinea, and another was advancing along the northern border of the Spanish protectorate.

In the result the advance on Yaunde was begun prematurely. It was undertaken as the result of a visit in March 1915 of M. Fourau, lieutenant-governor of the Middle Congo colony, to Gen. Dobell

at Duala. M. Fourau asked Dobell to cooperate with Aymerich in an immediate advance on Yaunde. Dobell demurred (the season was late, the rains were beginning and supply difficulties were great) and wished to be assured that Aymerich would be able to cooperate effectively in the vicinity of Yaunde. But his scruples were overcome and he consented to act at once. As events proved Aymerich was far from being able to give effective support. This Gen. Dobell did not know until May 17. In the meanwhile, on April 7 a column under Col. Hayward had moved E. and enabled Col. Mayer to advance from Edea on May 1. On May 3 Hayward, whose line of march was N. of that of the Mayer column, came to Wum Biagas, a strongly entrenched river position. This Hayward captured after an 18 hours' engagement. Thereafter Col. Mayer took over the command of the two columns, British and French, in the further advance on Yaunde. In all he had about 2,000 men, 300 of whom had been brought from Edea and were fresh.

Gen. Dobell, though he now knew that immediate help from Aymerich was not likely, decided to continue operations. Col. Mayer therefore left Wum Biagas on May 25, but from the first he met with strong opposition. In the dense bush, which sheltered an active and elusive enemy, the rate of progress was no more than a mile a day. Yaunde was still 40 m. distant and dysentery had broken out among the troops. Col. Mayer informed Gen. Dobell that any further advance was impracticable, and received orders to withdraw. This withdrawal was greatly impeded by the Germans, but at a critical moment Mayer was reinforced by some companies which had made a fine march in the tropical rain. By June 28 Mayer was back in the Edea district and the Germans ceased attacking.

While this first advance on Yaunde failed, Gen. Cunliffe in northern Cameroon achieved several successes. He had taken up his command in Feb. 1915, and his first important operation was the reduction of Garua, which was defended by Capt. von Crailsheim (with some 40 Germans and 400 native troops)—a man who won the admiration of his foes for his great courage and skill. Garua was invested in the middle of April and surrendered on June 10, after an unsuccessful sortie. A little later (June 28) Ndouere (nearly 300 m. N.E. of Yaunde) was occupied and here Gen. Cunliffe paused until Dobell was ready to renew his advance. Part of the interval was occupied in the unsuccessful attempt to take Mora by storm.

The new advance on Yaunde depended on the progress of Gen. Aymerich's columns. Col. Hutin, having been reinforced, occupied Lomie—150 m. S.S.E. of Yaunde—on June 25 1915, after many engagements. He was joined by over 300 German native troops, who had deserted. A month later, July 25, Col. Morrison occupied Dume—140 m. N.N.E. of Yaunde. Morrison had had severe fighting and a chequered experience since he began his march the previous Aug., having more than once been compelled to fall back before enemy counter-attacks. On Aug. 25-6 a conference was held at Duala between Gen. Dobell, Gen. Aymerich and M. Merlin (governor-general of French Equatorial Africa), when arrangements were completed for the final advance. Gen. Dobell renewed his offensive on Sept. 22; Cunliffe moved early in Oct.; Hutin and Morrison steadily pushed on from the east. Dobell had now received considerable reinforcements—his force had reached its greatest strength, 9,700, in November. Cunliffe had from 3,000 to 4,000 men; Aymerich about the same number; the French forces on the Spanish Guinea borders were 800 to 1,000; the Belgian column numbered 600—altogether the maximum Allied strength in the field was about 15,000. Except for a battalion of the Indian Army (sent to Cameroon nearly at the end of the campaign—and as a disciplinary measure) and a battalion of the West India Regt. (negroes) the whole of the rank and file employed were African natives. The German forces, old and newly raised, were estimated at a total of 10,000, including fully 700 white combatants.

For his final operations Gen. Dobell sent forward British and French columns separately—Col. Mayer advancing once more from Edea; the British under Col. Hayward from positions farther north. Again the dense forest was traversed, but now in the dry season and with adequate supply arrangements. The Germans, as before, vigorously opposed both the French and British columns. On Oct. 9 the British retook Wum Biagas, and on Oct. 30 the French took Eeska, the railroad. The British won through the forest first, and by Dec. 17 they were at Mangas, in open country and about 50 m. W. of Yaunde. Four days later the French column, which had had many casualties, was at Mangelas, 20 m. S.E. of Mangas. The British column, acting upon Dobell's instructions, had not waited for Col. Mayer to reach Mangelas, but pushed on straight for Yaunde which was entered, unopposed, on Jan. 1 1916, by Col. E. H. Gorges.

From Dec. 22 German opposition had ceased. Col. Zimmermann, as soon as he knew that both the British and French columns were clear of the forest, and aware too of the approach of Cunliffe and Aymerich, had determined to give up the contest. Together with the governor and 827 other Germans (including civilians), his native troops and thousands of carriers, he evacuated Yaunde, making S.W. for Spanish Guinea, the nearest point of which was, however, 125 m. distant. He was at once pursued, and in a rear-guard action fought on Jan. 8 Col. Hayward released 32 British and French who had been held prisoners by the Germans.

Col. Brisset's column coming from the N.E. was the next to reach Yaunde; then came Aymerich's columns, and Col. Morrison was detached to continue the pursuit of the Germans.



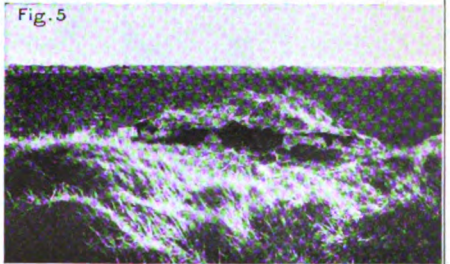
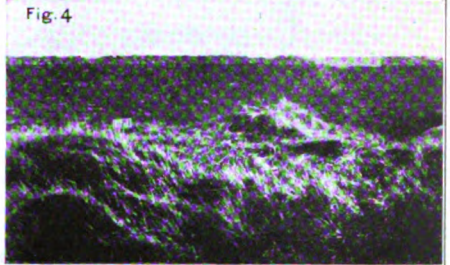
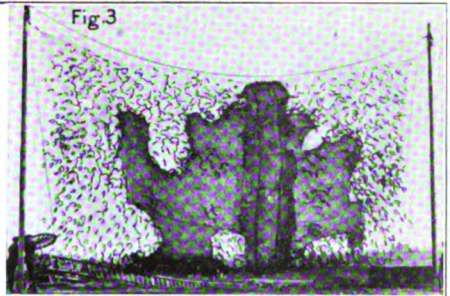

EXAMPLES OF THE USE OF CAMOUFLAGE DESCRIBED IN THE SECTION *MILITARY CAMOUFLAGE* OF THE ARTICLE CAMOUFLAGE.

FIGS. 1 and 2.—Treatment of a battery position placed under the edge of a bank. Note the false edge of bank.

FIG. 3.—Gun-cover consisting of net with opaque centre.

FIGS. 4 and 5.—Movable, lid-like cover for gun emplacements, disguised to resemble surroundings.

FIG. 6.—Imitation tree, designed to conceal an observer or a periscope.

FIG. 7.—“Chinese” silhouette figures for dummy attacks.

FIG. 8.—Sniper without cover, costumed to match surroundings.

FIG. 9.—Shooting from behind turnip heap,—one man in uniform, the other in sniper suit.





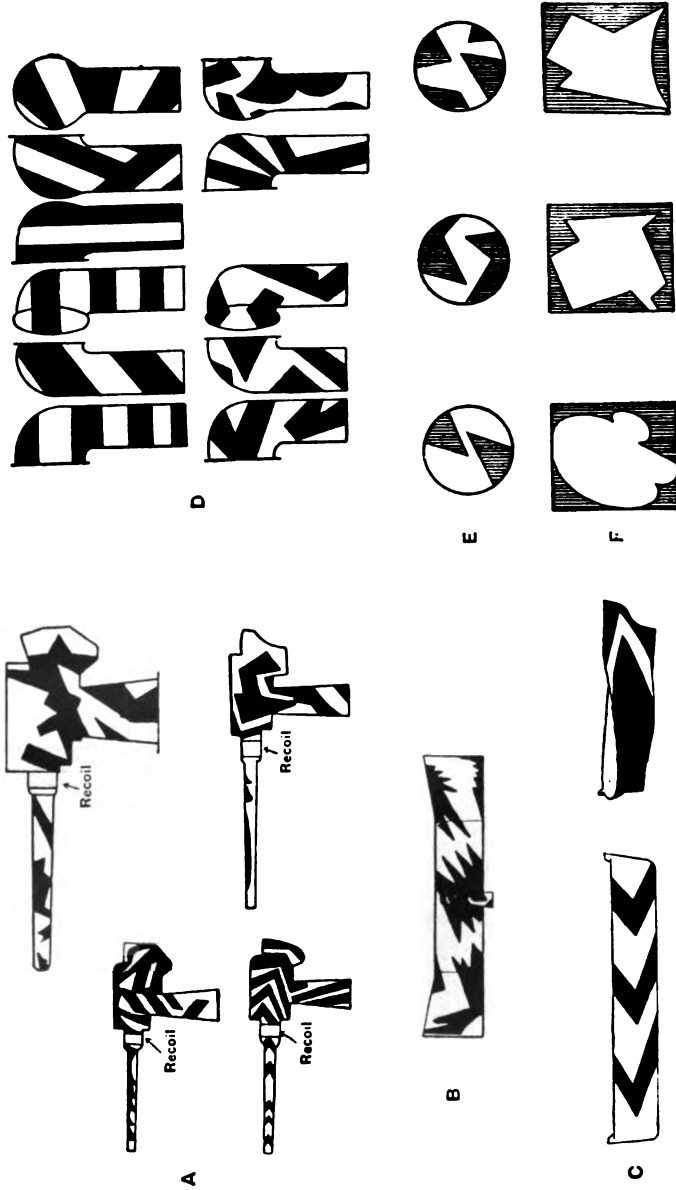

The above diagrams illustrate various methods for breaking up the form of A, Guns B, Gun screens C, boats D, ventilators E, round ports F, square ports, windows of chart houses etc.

DESIGN KX.  
Port Copy

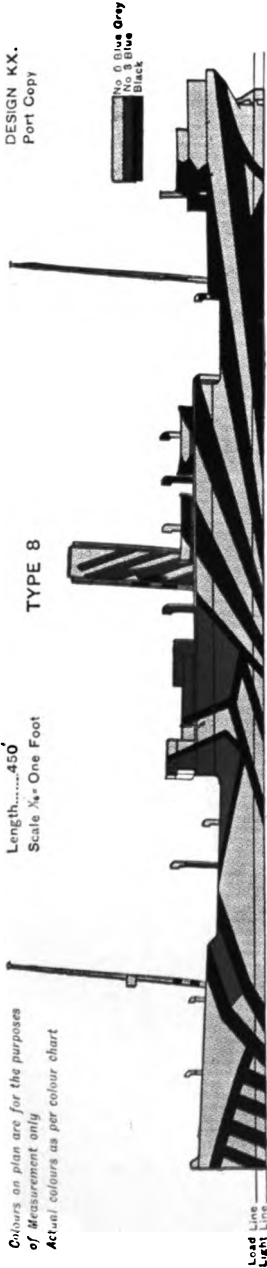

DESIGN KX.  
Starboard Copy

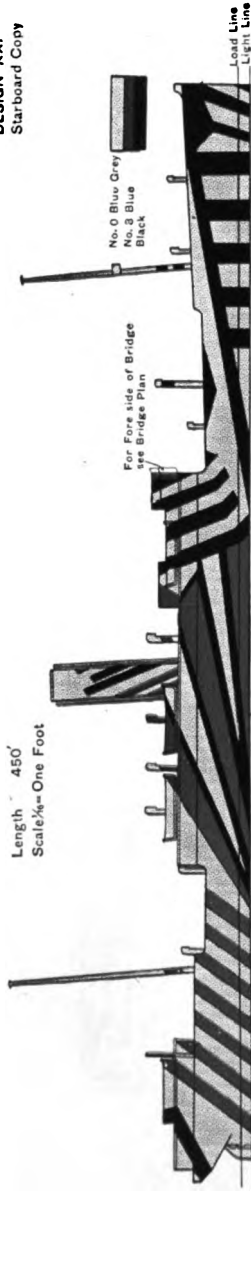

DESIGN KX.  
Bridge Copy

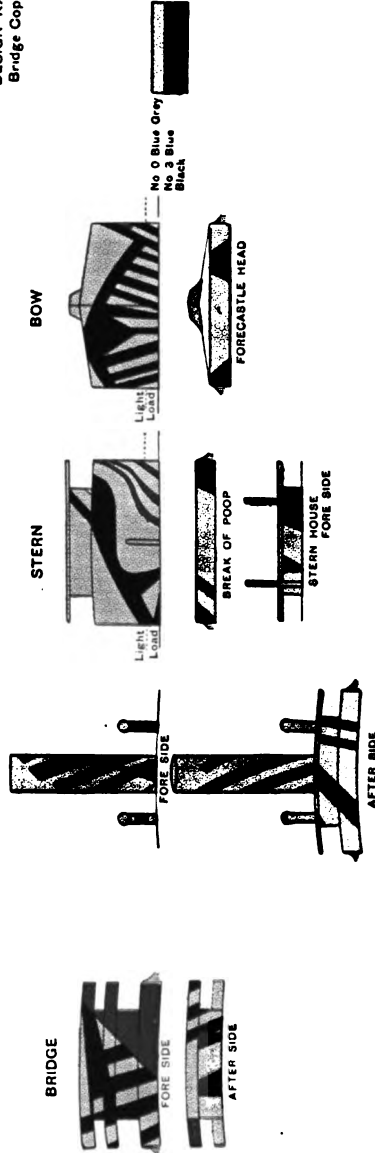

A typical plan as issued to painting contractors for painting merchant vessels under the Dazzle scheme (1/4 Scale of Original)

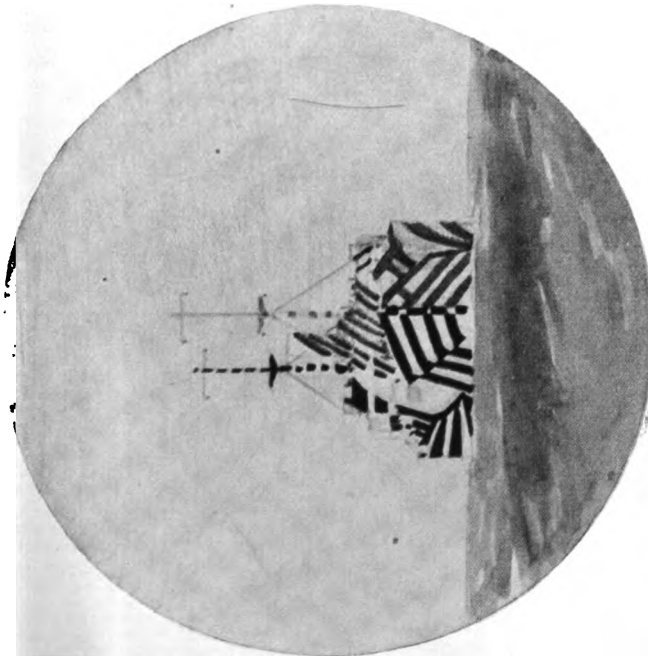

Merchant vessel dazzle-painted as seen through a submarine periscope.

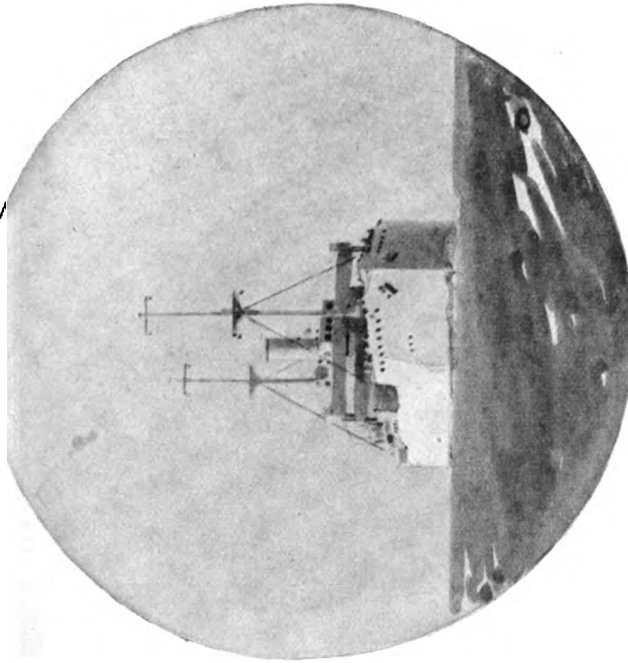

The same vessel on identical course painted grey.

1 Grey	2 Grey	3 Grey	1 Grey Green	2 Grey Green	3 Grey Green	1 Blue Green	1 Green	2 Green	0 Blue Grey
1 Blue Grey	2 Blue Grey	1 Blue	2 Blue	3 Blue	0 Grey Pink	1 Olive	White	Black	

Colour chart issued to painting contractors showing the principal colours used in dazzle-painting.

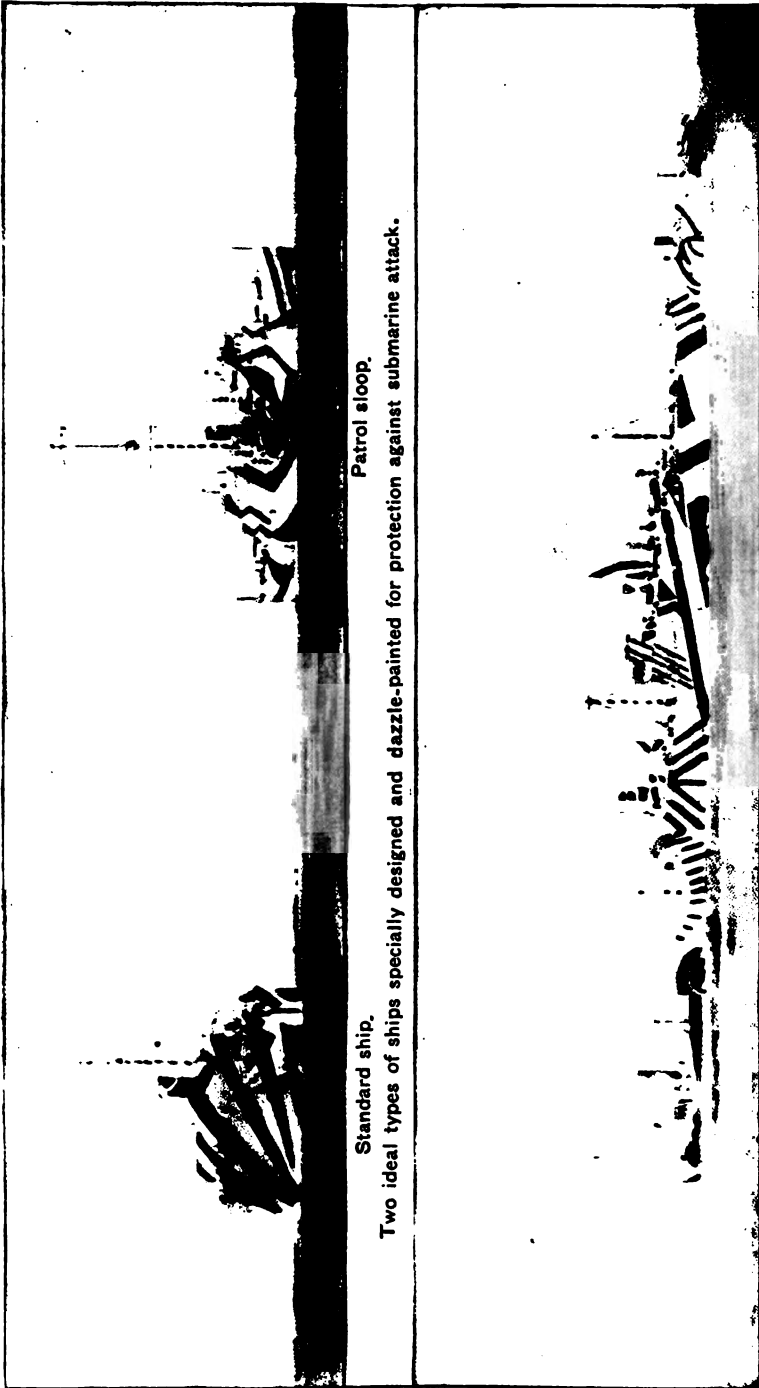

Standard ship.

Patrol sloop.

Two ideal types of ships specially designed and dazzle-painted for protection against submarine attack.

General appearance of a dazzle-painted convoy at sea.

Cunliffe's troops had been very stubborn fighting during this closing phase of the campaign, the most difficult operation being the capture (Nov. 4-5) of Banyo, a hill-fortress which lay some 200 m. N. of Yaunde and on the edge of that corner of Cameroon, the region towards the Cross river, where German resistance was continued to the last. In this quarter the Germans continued to offer determined resistance to Cunliffe's forces, and when on Jan. 2 1916 Cunliffe learned that Yaunde had fallen, his advanced troops were still 40 m. distant from that objective.

The efforts made to cut off Col. Zimmermann before he could reach neutral territory failed; the first part of his force entered Spanish Guinea on Feb. 4 and the other detachments quickly followed, and when on Feb. 18 1916 Capt. von Raben and his gallant garrison at Mora surrendered on terms after nearly 18 months' blockade, the conquest of Cameroon was complete.

See the despatches of Sir C. M. Dobbell and Gen. Cunliffe in the *London Gazette* (4th supplement) of May 31 1916; *The Times History of the War*, vol. viii., chap. 131 (1916), and *L'Illustration* (Paris, 1916) which gives valuable particulars of Gen. Aymerich's operations. (F. R. C.)

**CAMMAERTS, ÉMILE** (1878- ), Belgian poet, was born at Brussels March 16 1878. In 1908 he settled in England. His earlier works include four volumes of translations of Ruskin into French, and *Les Bellini*, an essay in art criticism; and he has also written two plays, *Les Deux Bossus* (1917) and *La Veille de Noël* (1917). It is, however, by the poems written during the World War that M. Cammaerts attained his widest popularity. These include *Belgian Poems* (1915); *New Belgian Poems* (1917); and *Messines and other Poems* (1918). He also produced *Through the Iron Bars* (1917), an account of the sufferings of Belgium during the World War.

M. Cammaerts married Tita Brand, a daughter of the singer Madame Marie Brema. MADAME BRAND-CAMMAERTS became well known during the World War for her recitations of her husband's patriotic poems. *Après Amers*, set to music by Sir Edward Elgar under the name of *Carillon*, was one of the great popular successes during the first two years of the World War.

**CAMOUFLAGE** (from Fr. *camoufler*, to blind or veil; It. *camuffare*, to make up), a French word which came into use, and was adopted into English, at the opening of the World War,<sup>1</sup> to express deceptive concealment, with all that it implies. Its real meaning may be defined as "concealment of the fact that deception is being practised or something being hidden." Deception is an essential ingredient, but concealment (in the sense of "hiding from view") is not. For example, protective colouration in nature does not render an animal invisible but indistinguishable.

Camouflage may be achieved by two distinct methods—(a) imitation (simulation), and (b) adaptation (dissimulation). The former is exemplified by the replacement of a real tree by a dummy one of exactly similar external appearance—the latter by so treating an object as to cause it to blend with its surroundings. The former is the method most widely employed in land warfare, whereas the latter is more common in nature.

In sea practice, camouflage was adopted during the World War in the form known as "dazzle painting" (see below). Bold and fantastic colour patterns were used for the purpose of misleading an observer as to the exact course being pursued by the ship; no attempt was made to render the vessel invisible.

## I. "NATURAL" CAMOUFLAGE

In the article **COLOURS OF ANIMALS** (see also 6.731\*) the methods of concealment among animals are described and classified from many points of view. It will be convenient, for the purpose of indicating their connexion with artificial camouflage, to separate them into two main divisions, one the method of direct imitation, and the other the method of general inconspicuousness.

Concealment by the first method is effected by the animal imitating some object in its natural surroundings against which it is commonly seen. It is clear that the better the imitation, the more effective the concealment. For instance, the leaf butterfly, *Kallima*, so closely resembles a dead leaf that when

<sup>1</sup> The French word *camouflé*, meaning a small and deep mine which on explosion does not break the surface of the ground, has been in use by military engineers for nearly two centuries.

resting among dead leaves it can only be located with the greatest difficulty. More often the animal can be found by careful search, but is likely to be overlooked, as, for instance, a tiger crouching amongst dead rushes. In all such cases a direct imitation, more or less exact, is made use of. The application of this principle in land warfare is discussed in section II below. The replacement of real trees by almost exact copies, internally fitted as observation posts, is perhaps the best-known example of camouflage of this class as practised in the World War.

The method of general inconspicuousness may be described under: (1) colour; (2) tone; (3) outline, and (4) modelling and cast shadow. These are the qualities by means of which an object is revealed and thus are those which an animal desiring not to be seen must conceal.

1. **Colour.**—The sandy-coloured desert animal and the green caterpillar are examples of the use of colour to produce general inconspicuousness. Browns, greens and greys, being common background colours, are usually used. Bright colours such as yellows and reds are occasionally made use of, for instance, by insects amongst autumnal foliage. Even before military camouflage had been systematically studied, most armies had adopted inconspicuous field service uniforms.

2. **Tone.**—This is a quality of great importance in camouflage, for the reason that aerial photography was largely used for its detection. In the concealment of animals it is also of considerable importance, though somewhat lost sight of in local colour. An animal which is either darker or lighter than its surroundings will be likely to be revealed in spite of being well coloured. In artificial camouflage it was found that the right tone could be more easily effected by texture than by, for instance, pigment. Thus, the imitation of grass could not be made with green paint on a smooth surface: from one point of view it might simulate well, but from another angle it would reflect a high light (see section II below). Roofs of buildings were concealed by covering them with hay, heather and brushwood stuck to the roof with an adhesive paint. The appearance of rough ground so produced could not have been obtained by any kind of painting. But although texture is of so much importance, it must not be thought that local colour can be entirely ignored. The aeroplane photographer used plates sensitive to particular coloured lights or colour filters which had the same effect, namely the detection of any fault in local colouration. The Germans used a green sensitive plate which, no doubt, would have detected a brown camouflage erected on a green field, even if the tone-matched had been good. Moreover, the aeroplane carries a human observer as well as the camera.

3. **Outline.**—The production of inconspicuousness by pattern is utilized by animals moving from background to background, which are now seen against foliage and now against brown earth. An animal broadly patterned in green and brown will appear inconspicuous against both these backgrounds and is recognized principally by its characteristic outline or silhouette. Against earth, only the green of the parti-coloured animal will be seen, and this will not have the characteristic shape of the animal, neither will the brown part of the pattern when it is viewed against foliage. The most efficient pattern is one which greatly disrupts the characteristic shape; one, for instance, which breaks out at conspicuous angles or across easily recognized straight lines and curves. Thus, birds commonly exhibit a pattern which divides the head into two, along the line joining the base of the bill with the shape of the neck, and the characteristic straightness of the tail is broken by cross-bars of pattern. A thin, dark or light, line separating the components of the pattern greatly aids its disruptive effect. This method of concealment has been used for guns and other objects, on which patterns of dark green and brown, separated by narrow black lines, were painted in large irregular blotches across the barrel, wheels and limber (see section II below).

There are other ways by means of which outline may be concealed. Among birds and insects fringes are sometimes made use of: viewed at a distance, the fringed edge has a blurred appearance causing the object to fade into its background. This principle of the fringed edge was freely and successfully employed in military camouflage, notably in the case of the flat-topped gun covers described in section II. Among insects an edge is often made to appear indistinct by a small marginal pattern of dark and light tone. When viewed at such a distance that the pattern is blended, the edge appears blurred. This is in principle quite different to disruptive patterns, which are only effective as long as they are visible, whereas the marginal patterns are only effective beyond their blending distance.

4. **Modelling and Cast Shadow.**—Modelling is revealed to the eye by the varying amount of light reflected from different parts of the object, and also by the shadow cast upon neighbouring objects. Animals and birds are often toned so as to appear flat by having those parts which are turned towards the light dark in tone; and those away from the light, light in tone. It is common to find the backs of birds dark-brown or black and their breasts white. When



viewed in the open, the high light which is reflected from the back is subdued by the dark feathers; whilst the darkness of the under parts is partially neutralized by the white breast feathers. The whole bird will thus appear evenly toned like a flat object and for this reason will be inconspicuous.

This method, called counter-shading, was occasionally made use of in military camouflage.

As regards the concealment of cast shadow, the only method employed by animals is to avoid them. Insects will turn and face the sun so that their closed wings will only throw a line shadow on the ground; others will tilt their wings parallel with the ground, thereby hiding the shadow which they cast. In military camouflage on the other hand the difficulty had to be faced, and an ingenious and successful method was evolved in the case of the flat-top gun cover. The cover consisted of wire or fish netting, on which strips of canvas were threaded and knotted. These strips were coloured green or brown in imitation of grass or earth. By gradually thinning out the knots at the edge, the shadow of the thickly knotted centre was hidden by the sparsely knotted margins which themselves cast little or no shadow.

The above outline will suffice to give a general idea of the relation between animal colouration and camouflage. But it should be added that the camouflager has much greater difficulties to contend with than has the animal on account of the extremely accurate and systematic observations made by the enemy with the eye from forward observation posts and kite balloons, and with the camera from aeroplanes. (J. C. Mo.)

## II. MILITARY CAMOUFLAGE

The word "Camouflage," in the broad sense of military deception, is applicable to all stratagems designed to mislead the enemy. In the following account it is used in the restricted sense of "deception practised through the agency of artists."

The application to war of camouflage, as thus defined, is by no means novel; dummy guns have been successfully employed to mislead an opponent on occasion ever since guns became a normal part of military equipment. Washington Irving in his *Conquest of Granada* records an instance in which the ruined wall of a blockaded town was repaired, without attracting the enemy's attention, under cover of a cloth screen painted to resemble a battlemented wall (circa 1484). The Venetians are reputed on one occasion to have imposed terms of peace on Ragusa by the expedient of building a threatening fort of cardboard in a position commanding the town. And when Henry VIII. of England besieged Tournai in 1513, the defenders used lengths of canvas, painted to resemble trenchwork, to mislead the besiegers as to the extent of the defences. Other instances could no doubt be brought forward in which camouflage was practised by individuals as an expedient. But it was not till the World War that it was practised by armies as a policy.

A transitional stage between the spasmodic use of camouflage in emergencies and its regular and systematic use as in the present day is marked by the painting, or other treatment, of coast defence forts to blend with their surroundings, in order to render them less conspicuous from the sea, e.g. Cork harbour, Isle of Wight, Singapore.

The well-known chequered black-and-white of the Spithead forts was an attempt to mislead the enemy as to the exact location of the gun embrasures. The same artifice was used in the case of the loopholes of blockhouses in the South African War of 1899-1902.

A further stage was reached in the adoption of uniforms coloured to blend with the usual or typical colours of the countryside in a theatre of war. The first of these was the Indian *Khaki* (see 15-770), and after the experience gained in the South African War, when the importance of concealment came into great prominence, the British and most other armies soon adopted dust-coloured, light-blue, grey, or grey-green uniforms.

Shortly after the South African War, experiments in the disruptive painting of guns were undertaken, but the system was not adopted, and no further development in the practice of camouflage took place until the war of movement of 1914 gave place to trench warfare. Hitherto deception in war had been limited to the comparatively simple task of deceiving the human eye, at a considerable distance, and for a short time. In the World War its rôle was extended to circumventing the camera, in addition to deceiving for long periods, the eyes of observers armed with powerful glasses. For the first time in history, a military unit was organized for the definite purpose of practising scientific deception.

This policy was initiated by certain French artists serving in a French battery towards the end of 1914. The interest of a French army commander was aroused and his sympathy enlisted, with the result that a "Section de Camouflage" was formed early in 1915, for the purpose of assisting units in the concealment of

battery positions and other military works, and the construction of concealed posts of observation. The success attained by this section led to the organization of the British Camouflage Service as a unit of Royal Engineers, early in 1916.

The need for organized camouflage is directly attributable to two novel features of the war, firstly the prolonged period of stationary warfare; and secondly, as an outcome of the first, the rapid development of aviation generally and of photography from the air in particular. Stationary warfare entailed the prolonged occupation of definite localities by troops, guns, and other numerous appurtenances of war, whose installation tended to become semi-permanent instead of temporary. It was therefore possible for each opponent methodically to examine the other's battle area in detail, and at comparative leisure, instead of relying on promiscuous and hurried reconnaissance, as in the past. It was soon recognized that photography provided the best means of executing such detailed examination, and presently the art of interpreting air photographs almost reached the level of an exact science. The information thus obtained far exceeded in quantity and accuracy that gleaned by observers, who could not but be distracted by the expanse of the view beneath them and the incidents of their adventurous journeys. All the resources of science were therefore devoted to the production of lenses, plates and colour screens, specially adapted to the needs of military intelligence. This evolution in the means of obtaining information necessarily called for a similar evolution in the means and methods of denying it, and a special service was organized for the study and practice of the science of camouflage.

The taking, developing and study of photographs demands a certain amount of time and special appliances, and still more so does the study, production, and application of camouflage, of which the progressive stages are performed on foot, in a large well-equipped factory, and in slow-moving lorries and trains. As long, therefore, as a condition of stationary warfare obtains, the maintenance of a special organization to practise camouflage is both necessary and possible.

But the conditions of a war of movement are quite different. Installations and constructions of all kinds are few. The occupation of localities by troops and guns is fleeting, and, in consequence, the camera loses its specialized usefulness. It follows, therefore, that the elaborate concealment of gun positions or other works is no longer necessary. Nor is it possible, for the transport, on which the camouflage service relies, is engaged to its utmost capacity in conveying the vital necessities of war, i.e. food and ammunition; and at the same time the factories, on which the supply of the material of camouflage depends, are being left farther and farther in the rear—or being engulfed by the advancing enemy, as the case may be.

The case may be summed up thus:—when accurate means of locating positions are employed, expert methods of concealment become essential; when the converse obtains, extempore methods suffice, though some form of portable camouflage, designed for use in moving warfare, and carried as part of their normal equipment by fighting troops, would be preferable.

There is ample evidence to prove that the Central Powers took no steps to organize a camouflage service till late in the war, though extempore methods of concealment were universal. Captured documents bear few allusions to the subject until after the battle of Cambrai in Nov. 1917. In the great offensive of March 1918, the Germans captured many specimens of camouflage together with pamphlets on the subject which they translated and distributed to all formations; at the same time arrangements were made for the quantity production of materials for concealing gun positions. In the Entente offensive of autumn 1918 many specimens of this material were captured for the first time, together with numerous examples of instructions on the practice of camouflage.

The principles and practice of camouflage may be dealt with under three heads: (1) the concealment of gun positions and the like from the enemy's aeroplanes ("air observation"); (2) the concealment of observation posts and machine-gun emplacements from direct view ("direct observation"); and (3) miscellaneous applications of camouflage.

(1) *Camouflage against "Air Observation."* The purpose of camouflage is to render objects indistinguishable, or un-

recognisable, by means of imitation or disguise. Concealment in the limited sense of "hiding from view" is not the primary aim. The ideal is non-interference with the natural, or normal, aspect of the locality, as viewed from the air, with which the enemy has become familiar. This is an ideal which can only be reached by close attention to detail, and by the exercise of forethought and imagination. Preliminary study of an aeroplane photograph of the locality will enable the effects of preparatory work, and subsequent active occupation, to be foreseen, and consequently make it easier to plan methods of combating them. These methods must be put into force before commencing work. To do so afterwards is futile, unless it is certain that no observation from the air has been possible during the progress of work. The processes of successful camouflage are closely analogous to those of successful crime—namely, preliminary reconnaissance, suppression of clues, provision of false clues, variety of method and concealment of the crime itself.

In the following study of the principles of camouflage the subject is dealt with in relation to the concealment of gun positions. In practice many other works were also concealed, such as machine-gun emplacements, defences, dumps, mine spoil, gas projector installations; but similar problems are encountered in all these cases.

Gun positions can be located by (a) aeroplane photography, (b) air observation, (c) flash spotting, (d) sound ranging. The two last furnish certain limited information. Beyond screening flashes, no method of frustrating them has yet been evolved. The manifest remedy (failing a silent, flashless propellant) is the skilful employment of dummy flashes and synchronized reports. But it is principally by means of photographs taken from the air that positions are definitely located on a map. The chief opponent to be overcome, therefore, is the expert, who, with the advantages of time and undisturbed concentration, which are lacking to the aeroplane observer, is able to interpret what is recorded on photographs. The aeroplane observer cannot, however, be altogether disregarded, and, although the main efforts must be directed towards defeating the air photograph expert, it must be done in such a way as not to draw the attention of the observer.

The camera is a most accurate witness, and a photograph will always record something. The art of camouflage lies in conveying a misleading impression as to what that something signifies. The photograph records colours and accidents of ground (such as bare earth, vegetation, woods, etc.) in terms of light and shade, and is a patchwork or pattern of black and white meeting in varying intensities of grey. The pattern may be large and simple like that on a chess-board, or intricate and confused like that on a painter's palette. A cultivated district presents a regular chess-board pattern, with large rectangular expanses of monotone, the only accidents to break the monotony being occasional hedges, banks, or houses, with their attendant shadows. Broken ground, such as demolished villages, shelled areas, or patchy vegetation, presents a highly complex pattern, full of merging lights and shades.

Photographically, the effect of colour is not so marked or important as the effect of light and shade. Earth is towards the white end of the scale, and grass or vegetation towards the black—not because of their respective colours but on account of the amount of contained shadow or "texture."

A billiard-table or top-hat illustrates this quality. Brush them the wrong way, against the nap, and their tone is lowered to dark green in the one case, and dead black in the other; brushed the right way they appear very noticeably lighter in tone. The reason is that they gain "texture" when brushed the wrong way, and lose texture when brushed the right way. In other words, they absorb light in the former case, and reflect light in the latter. Nap is constituted of countless slender hairs, each one throwing a shadow when erect, but casting little when flat. Grass, or vegetation, possesses this same property to a marked degree. The longer it is the darker it appears on a photograph; but when it is pressed down, the amount of shadow thrown is lessened, and consequently it appears lighter. Hence the obvious-

ness, on a photograph, of a slightly worn track in grass which is scarcely noticeable when viewed from the ground. Earth, on the contrary, contains little texture, and the longer it has been turned up and exposed to rain and sun, the less it contains. A beaten track is, however, conspicuous as it contains no texture at all, and will therefore reflect more light.

The reason for the mottled effect, in a photograph, of a patchy mixture of grass and earth, which blend imperceptibly into each other, is therefore evident. The appearance of snow can be divined from the foregoing. Contrasts in tone are much accentuated, and the effects of shadows are more marked, partly owing to the fact that snow usually falls at a time of year when the sun's path in the sky is low.

It is essential, when judging the colours of a locality, to view it vertically, and not obliquely as one is accustomed to see a flower bed. A field of young corn, surveyed from the ground, appears green, but from above, probably the earth only is seen, darker in tone than the normal, owing to the shadows cast by the young blades of corn. Similarly, with a field of ripe corn the actual light tone of the straw and ear will be somewhat darkened by their shadows.

It is of the first importance to grasp this principle of regarding any locality purely from the point of view of the pattern it will present on a photograph. Therefore, the most practical method of planning the concealment of any work is to plan it with reference to a recent photograph which records the ground pattern, and the natural facilities for concealment which exist in the locality. Such facilities abound in a neighbourhood whose photographic pattern is complex, and become less frequent as the pattern becomes less complex. Any slight error in exact reproduction may escape notice in the prevailing complexity, because detection depends on comparison, and comparison is rendered perplexing by the very intricacy of the pattern; the difficulty is enhanced by the variations present in successive photographs of the same place, due to dissimilar conditions of light. A simple analogy is the comparative visibility of an ink stain on a patchwork hearthrug and on a table-cloth.

There are certain characteristic clues which will always betray new work to the reader of aerial photographs. They are: (a) disturbance of soil; (b) tracks; (c) shadows; (d) regularity; (e) blast marks of guns. To achieve success, these clues must be suppressed from the very beginning. Or if deception is to be achieved by the use of dummies, these clues must be supplied.

The prolonged duration of the period of trench warfare was responsible for the introduction of many new methods of waging war scientifically. Among these was the systematic study of the enemy's normal activities, as gauged by observation over a long period, to determine such things as average intensity of gunfire, movements behind the lines, density of traffic, number of hospitals, size of dumps, etc. The chief evidence was obtained from photographs, taken at regular intervals, of the whole enemy front to a depth of several miles. Comparative analysis of this photographic diary revealed departures from the normal from which deductions could be made. It was therefore of the utmost importance to preserve an appearance of "normality."

Clues (a), (b) and (c) call for no special comment, but some further explanation may be added in the case of shadows and regularity.

**Shadows.**—The form of any erection, or excavation, is revealed in a photograph by the shape of the shadow cast. Two intersecting planes, e.g. the two sides of the roof of a building, will show differently on the photograph (except for a very brief period every day) because they receive light at different angles, and therefore reflect it differently. It follows that an artificial reproduction of locality must be erected parallel to the contours of that locality, or in other words the planes of the imitation and the real must not intersect. A mound must be imitated by a mound, and a flat surface by a flat surface. Any departure from this principle is most easily detected in a photograph taken when the sun is low, the shadows being long in consequence.

**Regularity.**—No shape in nature is of regular outline; consequently anything of a regular shape in a photograph invites scrutiny because it must be the work of human hands. In a battery position, regularity is usually displayed in the geometric shape of the gun-pits and the regular spacing and alignment of the guns.

It is now possible to sum up the theoretical conditions which govern the concealment of gun positions, and other works, from the enemy in the air:—

(a) The material of which the camouflage is composed must at all times appear on the photograph like the object or surface it represents, and likewise appear natural to the observer's eye. *Good* material, it must be light, strong, impervious to weather, fire-proof and easily manufactured. (b) Disturbances of soil, tracks, shadows, blast-marks and regularity must never appear to be associated with an active gun position or occupied work.

**Practical Application.**—We come now to the application of these principles. In the early part of the World War air photography was not the highly specialized art it subsequently became, and therefore the difficulties of combating it were not so great. At first, freshly cut branches and grass were used, being the materials nearest to hand. These withered in the course of a few days and ceased to be efficacious. The next stage was the employment of sheets of canvas painted to represent the ground. The design was bold, and consisted of large masses of green, or brown and green as the case might be, with heavy black shadings, to give the effect of texture. These covers were draped over the guns and came down to the ground on every side, being removed when the gun was in action and replaced immediately afterwards. This system also proved unsatisfactory. It is nearly impossible to reproduce on a smooth sheet of canvas the changing tones of the ground as recorded by the camera. Under certain conditions—i.e. when the angle of light incidence is small, or after rain—painted canvas, having no texture, reflects so much light that all trace of pattern or colour is lost.

Then came the introduction of fish netting. At first these nets were garnished sparsely with bunches of painted raffia (gardeners' bast). The effect was excellent; the nets were light and portable; but the inflammability of the painted raffia was a grave disadvantage. Efforts made to dye the raffia and to render it fire-proof proved fruitless. The dyes, especially green, were too fugitive, and no method of rendering the raffia permanently fire-proof could be discovered. Strips of painted canvas, instead of raffia, proved more satisfactory from the manufacturing point of view, but these also suffered from the defect of inflammability,<sup>1</sup> though in a lesser degree. The final evolution of the gun cover was a net having an opaque centre of painted scrim,<sup>2</sup> the shape of which was boldly irregular, with a border of painted canvas strips decreasing in density towards the edges, erected horizontally, like a carpet, over the work and much larger in area than the work itself (see fig. 3). Thus, the excavation was concealed by the opaque centre, the shadow of which was blurred or masked by the border of strips which, in themselves, were not sufficiently dense to cast a shadow. If skillfully erected and maintained such covers were satisfactory. Installed before any work of excavation was started, subsequent construction and occupation remained concealed. Guns could be treated individually or collectively by increasing the area covered. Figs. 1 and 2 show the treatment of a battery position placed under the edge of a bank. The false edge of the "bank" should be noted.

The use of netting was practically confined to works whose nature demanded covers erected at a considerable height above ground level. Scrim was used, by itself, to conceal objects near, or on, the ground, such as short lengths of trench, ammunition, gas-projectors; it should always be reinforced by natural material to increase its texture effect. Further, this material must always be cut or assembled in large fantastic shapes, in order to appear natural, and to allow its edges to merge gradually into its surroundings.

Many gun positions, which had defied all attempts at location, were betrayed by *snow*, particularly in respect of blast marks, because the flash of discharge melts the snow over a large area immediately in front of the gun. Further, shadows were accentuated, and the normal method of combating shadows, by the adoption of thinned edges, proved fatal in snow, as such nets

did not hold the snow and consequently appeared as black holes in a sheet of white. White calico proved a palliative, especially in the case of blast marks, if boldly irregular in shape.

Evidence afforded by *tracks* is perhaps the most difficult of all to eliminate. Frequently positions, which are admirably concealed in every other way, are betrayed by the tracks leading up to them, so much so, that it is often possible to count the number of guns in a battery by the paths leading to each gun-pit and to distinguish between gun positions and other works. It is comparatively easy to plan the approach so that it may be concealed naturally or artificially; the difficulty is to ensure that this and no other route is used—human nature being so strongly addicted to taking short cuts, barbed wire and discipline seem to be the only means of preventing it.

The following afford good illustrations of methods of concealing approaches that have been adopted with success: (a) Leading the track close past the gun position and on to join an existing track. The connexion to each pit being treated with camouflage material or cut grass, etc., etc. (b) Similarly, but close in front of the gun-pits in order to use the track to hide blast marks. This method has the disadvantage of restricting traffic while the guns are in action. (c) Siting a battery in the midst of an existing network of tracks, taking precautions to reproduce on the camouflage any path interrupted by a gun-pit.

It is not practicable to conceal long *trenches*. If a covering sags or differs materially in tone from its surroundings the mere length and regularity will betray it. A covering, originally perfect, will require continual attention to keep it perfect, involving labour out of all proportion to its value. Short lengths of trench can be concealed, provided care is taken to support the camouflage adequately to prevent sag, and to conceal the spoil.

This applies equally to trench systems prepared far behind the lines for use in the event of a retirement. It is probable that the enemy, foreseeing the construction of such a defensive line, will be able to guess the approximate positions of such systems, and he is certain to have periodically photographed the suspected area. It is quite impossible to prevent some traces of work being evident in a long and deep system of defences. Camouflage must obviously be restricted to vital spots, and extreme care must be exercised.

(2) **Camouflage against Direct Observation.**—The concealment of observation posts was comparatively simple, being merely an adaptation of the craft of theatrical property-making. Natural features were selected, in places from which good observation could be obtained, and these were copied exactly. At night, the real was removed and replaced by the imitation. A large variety of objects were so copied among which may be mentioned:—trees, sand-bags, milestones, mounds of earth, chimney-stacks, walls. In all cases the copy was a thin outer shell containing a bullet-proof lining in order to give confidence to the occupier. The loopholes, when subject to scrutiny at short range, could be made quite invisible by the use of gauze, which, though painted to resemble the exterior of the O.P., remained transparent from the inside. This method was only adopted when absolutely necessary, because gauze interferes with vision—especially through glasses; in other cases care was taken to give the loophole an irregular shape.

Certain conditions were found to govern the successful employment of these observation posts, particularly in the case of the more elaborate examples such as trees.

- a. Concealed access is essential.
- b. The work connected with installation must, like other work, be concealed from the air.
- c. They should not be erected in places that are normally subject to heavy shelling, for the reason that careful observation will be prejudiced and accidental damage will probably reveal the observation post to the enemy.
- d. Provision must always be made to prevent daylight showing behind the loophole, so rendering it transparent to the enemy.
- e. The comfort and security of the observer must always be studied, otherwise the full value of the observation will never be obtained.

Imitation trees (see fig. 6) were designed either to accommodate an observer at a commanding height above the ground, or to conceal a long periscope, the user of which was protected in a strong dug-out. In the former case the observer had a better view, but was uncomfortably cramped. The periscope is limited

<sup>1</sup> A solution of this problem of fire-proofing canvas was in sight when the Armistice put an end to its urgency.

<sup>2</sup> A kind of loosely woven canvas whose meshes give the effect of texture by absorbing light.

in respect of magnification, field of view, and clearness of vision, in proportion to its length. On the other hand advantage may be taken of its length to obtain high command with comparative security, or increased security with low command. Further, with suitable mountings, it can be used as an instrument of precision in conjunction with map and compass. Provision should always be made to give bullet-proof protection to the periscope when in use, and to allow of its being lowered for cleaning and safety when not in use.

It was sometimes necessary to construct *machine-gun emplacements* for defence in positions that either were, or might be, exposed to direct view. In certain cases the emplacement was incorporated in some existing rum, parapet, or such-like protection, where it was only necessary to conceal the embrasures. This was effected by the use of gauze painted to resemble the exterior, either in a hinged frame which could be removed for action, or fixed and fired through when need arose.

In other cases the emplacement was in the open. In such circumstances full precautions had to be taken to guard against detection by the camera also. An additional danger lay in the risk of detection from low-flying aeroplanes. To meet this a movable cover was evolved, in the nature of a lid, suitably disguised to resemble the surroundings (see figs. 4 and 5). Normally this lid rested on the top of the emplacement, overlapping it considerably; in action the lid could be raised vertically a foot or two, still affording protection against view from overhead, and also, to a partial extent, against long-distance direct view.

As a general rule, the *screening of roads* from observation by the enemy is not in the province of camouflage, in that no deception is attempted, the main object being to conceal traffic from direct view.

In a few instances true camouflage was practised when a screen painted to represent the enemy's accustomed view of the locality was erected between the road and the enemy, so that the road would always appear unobscured even while traffic was passing behind the screen. Such an expedient was restricted to a few favourable places, such as occasional gaps in a road otherwise entirely hidden from view, or open spaces at a village where the ruins for the most part obstructed the enemy's vision. These screens were impracticable in cases where the portions to be concealed exceeded a few yards in length, as they were exposed to the weather and casual shelling, and therefore had to be very strongly constructed. This, combined with the necessity of complete erection at night and the fact that they could be used only where the locality was not subject to marked seasonal changes, considerably limited their use.

(3) *Miscellaneous Applications of Camouflage.*—It was only natural that, after a camouflage unit had been organized, with skilled personnel and well-equipped workshops, there was a wide field for the display of ingenuity. For the most part the field has been covered in the foregoing sections dealing with the methods of combating air and ground observation, but it will be of interest to give a short description of devices that fall outside these two categories.

*Dummy Attacks.*—In 1917 the practice of raiding the enemy trenches increased in frequency and scale, and in order to secure the best results with the least expenditure of life, dummy attacks were frequently staged on the flanks of the real front of attack, and set in motion a few moments before it. The dummy (or "chaise" as it was called) attack consisted of numbers of life-sized silhouette figures, made of stout millboard and painted to resemble the various postures of advancing troops. These figures were placed in scattered groups of ten, and suitable arrangements made to raise and lower them at will from some place of safety, so that they simulated waves of advancing troops (see fig. 7). In the early light of dawn, or partially obscured by smoke, they were very realistic, but success depends on skilful operation of the figures rather than on the painting. Directly the enemy's fire was drawn the real attack was launched with the comforting knowledge that many precious moments must elapse before the enemy could switch his fire off the dummy attack on to the real attack.

Similarly, the location of enemy snipers was facilitated by the use of *dummy heads* made of papier-mâché. These were exposed over the parapet, in a life-like manner, in order to draw the fire of an enemy sniper. If the head was hit, it was possible to locate the exact position of the sniper by producing the alignment of the

holes of entry and exit of the bullet. It was necessary to paint these heads with a matt surface, darker in tone than the natural, in order to imitate the texture of the human face.

*Sniper Suits.*—The concealment of snipers and scouts was facilitated by the wearing of costumes painted to match the surroundings. When garnished with local vegetation, and used skilfully, it was extremely difficult to discover the wearer. Fig. 8 shows an exceptionally tall man lying quite in the open, but wearing a sniper's robe. Fig. 9 shows, in contrast, two men firing from behind a turnip heap, the one wearing the ordinary uniform cap and the other a sniper's robe suitably garnished. In each case the photographs were taken at a distance of only 8 yds.

*Disruptive painting*, as a method of reducing visibility, has been alluded to in an earlier section of this article. Its simplicity makes a strong appeal to the imagination, and a large number of objects, including guns, were so treated. The colours employed were green, cream and brown, isolated from each other by thick black lines. The principle is that one or more of these colours is capable of merging into any surroundings, leaving the visible remainder as a number of detached patches of colour, thus breaking up the form of the object into a number of dissociated pieces. The contrasts in colour must be marked, and the patches large enough to be distinct when viewed from the appropriate distance; otherwise the colours will blend and, in consequence, the disruptive effect will be lost. An effect of texture is also essential to prevent reflection. In the case of guns, it was soon found that the wear and tear of active service caused the colours to lose their contrast and, consequently, their disruptive effect. The system was therefore abandoned.

In the case of large buildings and camps, the disruptive effect is nullified by their mass, heavy shadows and quite inevitable regularity of lay-out.

*Camouflage Material and Its Production.*—By no means the least difficult part of the whole problem of camouflage was that of producing the material in sufficient quantities to meet the enormous demands. At first each position was treated individually as a separate problem, but it was very soon obvious that although this principle was desirable it was quite impossible, in view of the number of positions to be dealt with. It was evident that a system of standardization was imperative, in conjunction with some method of adapting the general to the particular. Standardized manufacture was therefore adopted. It was recognized that in certain cases standardization could not be applied; but experience showed that the proportion of such cases was small. In all cases the material was capable of some degree of adaptation to local conditions.

For gun positions, etc., three distinct models were furnished—fish nets, wire netting and scrim.

*Fish Nets.*—The nets themselves were supplied from England. The size, 30 ft. by 30 ft., was fixed as being the minimum suitable for universal application; one or more nets could be easily joined if necessary. The nets were woven "square" in contradistinction to "diagonal," because the diagonal net closes when extended, of the principle of "lazy tongs." The meshes were 2½ in. square. The outside was bound with strong cord to take the tension, and the whole was treated with a non-inflammable preservative. The garnishing of these nets has already been described. The nets were commonly used for all types of guns and were in demand because of their comparative portability.

*Wire Netting* was used in large quantities also, being stronger than fish netting, though less portable. For convenience in handling it was made up in rolls 30 ft. long, averaging 6 ft. wide, and was garnished in a fashion similar to fish netting, except that the thinning process could only be applied to the ends. In the field these rolls were joined up to suit the work they were intended to cover, and the thinning-out process was completed on the site.

*Scrim*, as already mentioned, by itself was mainly used on or near the ground and was issued in 30 ft. by 6 ft. rolls for a variety of purposes. Towards the end of the war, when night bombing became very persistent, scrim was used to cover aeroplane hangars (whose light-coloured roofs were very conspicuous at night), until coloured covers became the normal equipment of a hangar.

*Colouration.*—In these three types four standard colourations were adopted, suited respectively to areas where the predominant conditions were: all vegetation, all earth, partly earth and mostly vegetation, partly vegetation and mostly earth. Both the scrim centres and the borders of strips were coloured in this way.

*Observation Posts, etc.*—Standardization of the exteriors of observation posts was not possible for obvious reasons, but the principle was applied to the bullet-proof interiors and other component parts. They were classified as: observer trees, periscope trees, parapets (sandbag or earth), portable O.P.'s. In addition there were many

special situations provided for. Other standardized articles were dummy attack figures, dummy heads, snipers' suits and portable covers for machine-guns—these last-named reversible squares of scrim 8 ft. by 8 ft., green on one side, brown on the other; made very light and portable for use in the field.

**Manufacture.**—Although a description of the methods of production is beyond the scope of this article, discussion of the principles and practice of camouflage would not be complete without some reference to the important part played by materials, particularly canvas and paint.

Canvas is not an ideal material, being very susceptible to damage by weather, but it is easy to manipulate and is cheap. From the point of view of appearance, it is inferior to *rafia*, which, however, suffers from the hitherto insuperable disadvantage of inflammability. "Water" paints were generally employed for canvas for the reason that oil paints, which are more durable, are too inflammable, even to the extent of spontaneous combustion. This latter disability was the cause of disastrous fires where rolls of painted canvas were stored. Green dye proved too fugitive, but brown dyes proved satisfactory. Generally speaking, canvas and paint do not adequately fulfil the conditions of lightness and durability.

(F. J. C. W.)

### III. NAVAL CAMOUFLAGE

The painting of vessels of war with a view to reducing their visibility and so adding to their fighting value is by no means a modern development. The Romans are known to have painted their galleys; "seven kinds of paint were used, viz. purple, violet, yellow, two kinds of white, and green for pirates in order that their resemblance to the colour of the waves might make them less conspicuous."

Camouflage on various lines but with the invariable idea of reducing visibility had been attempted in the British navy for many years before the World War. None of these schemes had met with any success, and each in turn had been abandoned after furtive trials. The two factors which led to this abandonment were first the failure to realize that anything in the nature of invisibility at sea is possible of attainment, and secondly the inability of the proposers of these schemes to provide definite instructions of a practical nature by which vessels could be painted with some degree of consistency.

The Board of Admiralty eventually adopted a partial form of camouflage by painting all vessels a light grey as opposed to the black hulls and light upper works previously in force. But even this simplest form of all protective measures was somewhat haphazard in application, since the individual vessels of a squadron varied considerably in colour, ranging from a light bluish grey to a dark slate according to the ideas of the commander.

It was not until 1917, during the height of the submarine peril, that a practical scheme having a definite end in view and formulated on scientific lines was put forward and officially adopted by the British authorities. This scheme embodied entirely new ideas on sea camouflage, and was rescued from the early disease which had attended all its predecessors by the fact that the proposer was able to supply designs to scale in large numbers, all bearing out a central idea. It was called for distinction's sake in official documents "Dazzle Painting." The sole object of dazzle painting was so to distort the normal appearance of a vessel that her actual course became a matter of doubt in the mind of a submarine officer, the estimation of a vessel's true course being the prime factor required to ensure successful attack.

Dazzle painting was intended primarily for application to merchant ships. These vessels were in far greater need of protection than warships owing to their slow speed and vulnerability and also from the fact that the enemy were making a concerted attack on England's supplies of food and materials essential to the conduct of the World War.

Warships as a rule possessed high speed and were moreover protected by destroyers, a type of vessel which while being the most deadly opponent of the submarine was comparatively immune from attack. A certain number of war-vessels were however dazzle-painted. These were chiefly ships engaged on convoy work, although a certain number detailed for special duties such as mine-laying and patrol service found this special form of protection of valuable assistance.

At first sight it would appear impossible to treat a vessel with paint in such a way that an experienced seaman could be deceived as to her actual course, but dazzle-painted ships proved that this could be done. juxtaposition of violently contrasting colours, black and white predominating, combined in accordance with the laws of perspective, could make it extremely difficult to judge the accurate inclination of a vessel even at a short distance.

In the early stages of dazzle painting a large range of colours was employed to achieve the end in view. Experience showed that this could be attained by a much smaller number, and towards the end of the war the principal colours in use were black, white, and blue, these being employed in varying intensity.

Another factor which led to the simplification of the colours used was the knowledge that the German naval authorities had introduced the use of colour screens in their submarine periscopes with a view to reducing the camouflage ship to a silhouette, and so neutralizing the effect of the colours used. These screens however had no effect whatever on a design depending solely on black, white, and blue for its contrast. Shortly after its adoption by the Admiralty dazzle painting was incorporated under the Defence of the Realm Act and the whole merchant service was ordered to be painted. Numbers of war-vessels operating with merchant ships were also painted: these comprised chiefly convoy cruisers, sloops and destroyers. The 10th Cruiser Squadron, engaged in blockade duties and composed entirely of large merchant ships, was also painted. These vessels were specially liable to attack, being at sea for long periods in submarine-infested zones and constantly under slow speed or altogether stopped for boarding purposes.

On the introduction of the scheme a considerable volume of maritime opinion was directed against it from lack of a proper grasp of its objects and because it appeared to render a vessel more conspicuous than was the case when painted grey. In point of fact at the date of the submission of the scheme the proposer, who was on patrol duty in the channel, had noted that all transports were painted a dead black from water-line to truck. The opposition, however, rapidly disappeared as soon as the objects of the scheme were thoroughly grasped and the rapidly increasing numbers enabled seamen to judge for themselves the difficulties of accurately estimating the accurate courses of dazzle-painted ships met with at sea.

The organization for producing designs in great variety and arranging for the rapid application of the designs to large numbers of vessels of great diversity of types was as follows:—

The mercantile marine was divided into 37 classes of characteristic types. For each type a small wooden model was made to scale and on this model a design was painted in wash colours. It was then carefully studied in a prepared theatre through a submarine periscope with a view to obtaining the maximum distortion. Behind the model were placed various sky backgrounds, the conditions of an average day at sea being obtained as nearly as possible. The model was slowly revolved on a turntable and observed from every point of view necessary, alterations and additions being made until the distortion became such that an independent observer found it a matter of considerable difficulty to judge its orientation.

The model was then handed to a trained plan-maker who transferred the design in colour to a 1-16 in. scale plan on white paper showing port and starboard side (see Plate I.). Each colour on the plan was numbered to conform to the official colour charts, which gave a complete range of all colours used in dazzle painting (see Plate II.). It was one of the important factors essential to the success of the scheme that these colours should be rigidly adhered to by painting contractors.

The Dazzle Department was represented at all the principal shipping ports by one or more officers specially trained for the work. These officers were responsible for the issue of plans and the supervision of all ships painting in their districts. This work entailed a great deal of highly skilled supervision, as the actual painting fell upon the local painting contractors, whose men were entirely new to this kind of work. With the rapid expansion of the scheme however, upwards of 100 vessels were sometimes in hand at one port, difficulties were overcome and the work proceeded smoothly.

Soon after the establishment of the Dazzle Department, inquiries were made by the Allied maritime governments as to the efficacy of this new form of defence against the submarine. The French Ministry of Marine attached three officers for training under the new scheme and shortly afterwards set up a

similar department in Paris. The U.S. Navy Department asked that an officer might be sent to Washington; shortly after his arrival a dazle department was formed to deal with U.S. shipping. The Belgian Government arranged for all their merchant vessels to be dealt with directly in the British department. Complete sets of plans were forwarded to Italy and Japan.

All U.S. destroyers and other patrol vessels in European waters were painted from plans supplied from the British department.

The number of vessels saved by this device can never be definitely ascertained as it cannot be known how many attacks were broken off by enemy submarines owing to a wrong position having been taken up as a result of inaccurate estimation of the vessel's course due to the dazle painting. But the rapid expansion to all Allied merchant shipping showed that the authorities were satisfied that it played a great part.

Approximately 4,000 merchant ships were painted and upwards of 400 war-vessels engaged principally in convoy and patrol duties were also painted. The total cost of painting amounted to some £3,500,000. (N. W.)

**CAMPBELL, BEATRICE STELLA** (Mrs. PATRICK CAMPBELL) (1865- ), English actress (see 5.127), appeared at the Haymarket theatre, London, in *Lady Patricia* in 1911, and later in the same year at the St. James's theatre in *Bella Donna*. She also played Eliza Doolittle in Mr. Shaw's *Pygmalion* at His Majesty's theatre in 1914, and Leonora in Barrie's *The Adored One* at the Duke of York's theatre in 1913. In 1914 she married Mr. George Cornwallis-West. In 1917 she appeared in B. Veiller's American melodrama, *The Thirteenth Chair*, at the Duke of York's theatre, London, and in Nov. 1920 she played Lady Macbeth in Mr. James K. Hackett's production of *Macbeth* at the Aldwych. Her daughter, Stella Campbell, also became an actress.

**CAMPBELL, SIR FRANCIS J.** (1832-1914), British educator, was born near Winchester, Tenn., U.S.A., Oct. 9. 1832. Having been blind from the age of three, he was educated at the school for the blind at Nashville, Tenn., and later at the university of Tennessee. He also set himself to learn music, and went to the conservatoires of Leipzig and Berlin. In 1872 he became principal of the Royal Normal College and Academy for the Blind at Norwood near London, which he, with the 1st Duke of Westminster and other philanthropists, had helped to establish: He retired in 1912. Amongst his recreations was Alpine climbing, and in 1885 he ascended Mont Blanc. He died at Norwood June 30. 1914.

**CAMPBELL, REGINALD JOHN** (1867- ), British divine (see 5.130), retired in 1915 from his ministry at the City Temple and in 1916 was ordained a clergyman of the Church of England. He became an hon. chaplain to the Bishop of Birmingham, and in 1917 was appointed vicar of Christ Church, Westminster.

**CAMP FIRE GIRLS:** see BOY SCOUTS.

**CAMPS AND CANTONMENTS:** see BARRACKS AND HUTMENTS.

**CANADA** (see 3.142).—Important measures, extending the boundaries of the provinces of Quebec, Manitoba and Ontario, were passed by the Canadian Parliament during the session 1911-2. The areas of the provinces and territories (for which see the separate articles under each heading) are given in Table I.

TABLE I.—Area and Population

Provinces	Area (sq. m.)			Pop. per sq. m. of land area (1911)
	Land	Water	Total	
Prince Edward Island	2,178	—	2,184	42.9
Nova Scotia	21,068	360	21,428	23.3
New Brunswick	27,911	74	27,985	12.6
Quebec	690,865	15,969	706,834	2.9
Ontario	365,880	47,382	407,262	6.9
Manitoba	231,926	19,966	251,832	1.9
British Columbia	353,416	24,339	355,855	1.1
Alberta	252,925	7,369	255,265	1.5
Saskatchewan	243,882	8,318	251,700	2.0
Yukon	206,247	649	207,076	—
North-west Territories	1,207,496	34,298	1,242,224	—
Totals	3,601,910	125,755	3,729,665	2.0

The water area given is exclusive of Hudson Bay, Ungava Bay, the Bay of Fundy, the Gulf of St. Lawrence, and all other tidal waters except the part of the St. Lawrence between Pointe-des-Monts and the foot of Lake St. Peter in Quebec.

There was in 1921 a fairly strong movement to unite Nova Scotia, New Brunswick and Prince Edward Island under a single government as a province to be known under the old name of Acadia.

**Population.**—The growth of pop. is shown by the following figures: 1871, 3,485,761, 1881, 4,324,810, 1891, 4,833,239, 1901, 5,371,315, 1911, 7,206,643. The pop. in 1921 was estimated at between 8 and 9 millions. The rate of increase of pop. greatly increased after 1896 on account of immigration from Great Britain, the United States and parts of central Europe. There are German settlements in Ontario and Nova Scotia, while Russians, Galicians, Polish and Russian Jews and Scandinavians have emigrated in large numbers to the western provinces and territories.

**Immigration.**—Table II shows the immigrants entering the country for the fiscal years 1911 to 1921 inclusive.

TABLE II.—Immigration

	From U.K.	From U.S.A.	From other countries	Total
1911	123,013	121,451	66,620	311,084
1912	138,121	133,710	82,406	354,237
1913	150,542	139,009	112,881	402,432
1914	142,622	107,530	134,726	384,878
1915	43,276	59,779	41,734	144,789
1916	8,664	36,937	2,930	48,531
1917	8,282	61,399	5,703	75,374
1918	3,178	74,334	4,582	79,074
1919	9,014	40,715	7,073	57,702
1920	59,603	49,656	8,077	117,336
1921	74,262	48,059	26,156	148,477

During 1911-21 18% British, 26% American and 29% of immigrants from other countries made entry for homesteads in western Canada. These figures do not account for the large number of farmers and farm labourers of the immigrant class who settled in all parts of the Dominion without homesteading. The number of Chinese immigrants during these years was 31,913 and of Japanese 7,195.

**Municipal Statistics.**—Table III. gives the statistics of cities and towns of 10,000 and over, showing population, total assessed value of the taxable property, and liabilities, for the year 1919.

**Agriculture.**—The value of agricultural production in the Dominion, including live stock in hand, was in 1918 about \$2,360,000,000, or nearly twice the value of the production of manufactures and over 12 times the value of mineral production in the same year. It was estimated by the Department of the Interior that in 1921 there were still 200,000,000 ac. of vacant land in the Middle West available for, or at least susceptible to, some form of agriculture.

The only item of agricultural production in which in 46 years up to 1918 there was shown a decrease was the number of sheep (2,369,458 in 1917; 3,155,509 in 1871). It is difficult to account for this, except for the fact that the price of wool was for many years very low, and sheep have always been in Canada what a commercial man would call a side-line. Canada, however, is especially well adapted for sheep and goat raising and breeding. There are millions of acres, not only in the West but in the older provinces, that could be used for the purpose without impinging on the other more fertile lands. In portions of Ontario, Nova Scotia and New Brunswick there is much cleared and partly cleared land apparently going to waste that might be devoted to sheep culture. In the Middle West and in British Columbia there are approximately 50,000,000 ac. suitable for sheep and goat culture. There are no long droughts, as in Australia, and there is comparative immunity from disease, in the past the great enemies of sheep in Canada have been dogs and wild animals.

Factory cheese (194,994,336 lb. in 1917; 220,833,269 lb. in 1900) also suffered a decline in production, on account of the greater demand for creamery butter and the more profitable outlet for milk and cream in the urban centres. So great is this latter demand that the whole of N. America is affected by it. In live stock—particularly dairy and beef cattle (7,020,490 head in 1917, 2,624,290 in 1871) and swine (3,619,382 in 1917, 1,466,083 in 1871)—lies Canada's greatest agricultural prospect, because cattle give to the soil the greatest return in fertility. They are the necessary link in the rotation of crops, and Canada, with her vast area, her abundant water, her adaptability for growing fodder crops, and her advantageous position in respect of foreign markets for dairy products and meats, is in a position of great advantage. Despite the use of motors, the number of horses in Canada has increased (3,412,749 in 1917), and there is still a good future for selected breeds of draught, riding and race horses.

On account of the labour situation, in which farmers are practically deprived of outside help, agriculture in Canada, as elsewhere in America, resolves itself into self-help, and therefore has become a question of small mixed-farming, limited to special lines in which machinery may be utilized and only a minimum of labour required. In the Maritime Provinces and Ontario farms are practically denuded



TABLE III.—Principal Cities.

City	Population	Total assessed value taxable property	Total liabilities
Montreal	706,600	\$623,820,959	\$124,802,327
Toronto	499,278	642,816,690	109,849,002
Winnipeg	200,000	236,023,520	46,122,938
Vancouver	123,090	205,044,673	29,054,524
Quebec	114,550	73,038,256	15,762,542
Hamilton	108,143	87,157,896	15,888,922
Ottawa	107,732	120,465,566	19,423,756
Calgary	75,000	77,943,910	27,850,087
Edmonton	66,000	79,306,320	37,585,100
Halifax	60,000	37,330,810	
St. John	60,000	46,013,550	5,114,562
London	59,100	40,783,044	8,263,283
Victoria	50,000	71,897,065	22,823,558
Regina	40,000	40,982,515	11,675,961
Brantford	33,000	15,718,805	5,202,831
Windsor	31,629	32,953,994	3,881,288
Verdun	28,432	15,085,400	3,488,372
Hull	28,392	9,465,860	2,428,844
Saskatoon	28,000	28,433,044	10,234,119
Sydney	25,000	9,245,854	2,075,500
Three Rivers	25,000	16,356,575	4,835,783
Kingston	23,737	13,016,727	2,023,698
Moore Jaw	23,155	20,612,578	8,339,034
Sherbrooke	22,583	42,923,261	4,539,104
Peterborough	22,000	13,112,605	2,862,290
Sault St. Marie	21,500	17,650,178	2,977,878
Kitchener	21,032	11,957,859	2,000,486
Fort William	20,000	21,973,486	9,146,431
St. Thomas	20,000	10,248,310	270,432
Westmount	19,500	44,583,350	6,867,517
St. Catharines	19,196	15,465,385	5,246,489
Moncton	19,000	19,000,000	
Stratford	18,106	8,858,350	2,424,209
Guelp	17,032	8,832,030	2,073,730
Lachine	16,500	13,661,338	2,609,049
New Westminster	16,000	16,645,212	6,234,496
Port Arthur	15,000	22,574,399	4,600,107
Sarnia	14,649	11,092,243	1,540,394
Brandon	14,421	15,447,978	3,759,078
Niagara Falls	14,307	10,759,286	1,218,709
Charlottetown	14,000	5,794,308	838,600
Outremont	12,650	17,750,251	3,321,446
Galt	12,500	7,580,914	2,008,969
Belleville	12,345	6,240,165	1,465,531
St. Boniface	12,225	12,547,265	5,271,828
Lethbridge	12,000	11,723,655	4,573,400
New Glasgow	12,000	5,331,530	972,808
Owen Sound	11,768	7,022,883	1,501,985
Coventry	11,000	4,844,430	1,030,161
Medicine Hat	11,000	14,292,538	4,483,238
St. Hyacinthe	10,541	4,233,818	1,313,318
Woodstock	10,150	5,428,345	980,468
Levis	10,000	3,556,695	949,711

TABLE IV.—Field Crops.

	1918	1919
Wheat (fall)	16,516,000	31,524,000
" (spring)	365,451,700	333,436,000
Oats	331,357,400	317,097,000
Barley	17,462,570	17,462,700
Rye	12,728,600	14,240,000
Peas	12,899,100	9,739,380
Beans	10,283,900	6,214,800
Buckwheat	18,018,100	15,831,000
Flax	18,951,000	22,609,500
Corn	24,902,800	22,280,000
Potatoes	102,235,500	118,894,700
Turnips, etc.	52,452,000	54,958,700
Hay and Clover	241,277,300	338,713,200
Grain Hay (B.C.)		4,379,000
Fodder Corn	29,439,700	34,179,500
Sugar Beets	2,606,000	2,606,000
Alfalfa	7,966,500	10,800,200
Mixed Grains	40,726,500	37,775,400
	1,372,935,970	1,452,437,500

TABLE V.—Agricultural Products, etc.

Dairy Products:	1917	1918
Factory Butter	34,274,248	41,839,156
Factory Cheese	41,180,623	38,456,532
Miscellaneous		32,995,241
Total Dairy Products		113,310,929
Live Stock:	1918	1919
Horses	459,155,000	435,070,000
Milk Cows	307,244,000	317,814,000
Other Cattle	39,811,000	381,000,000
Sheep	48,802,000	50,400,000
Swine	118,781,000	102,399,000
Total Live Stock	1,326,766,000	1,296,602,000
Other Products:		40,000,000
Eggs and Poultry (estimated)		
Fruits		1,975,841,000

Forests.—Canada's annual forest growth is several times as much as the annual cut. The production of timber was valued at \$90,000,000 in 1917. The Federal Government has jurisdiction over the timber of the three Middle West provinces, and of the Territories and of the Railway Belt in British Columbia, and has created Federal reserves to the extent of over 28,000,000 acres. It carries on, in addition, an extensive system of seeding and free distribution of seeds in the three prairie provinces. In 1917 it allotted nearly 8,000,000 trees to about 10,000 applicants and the Government farms had 9,000,000 seedlings and cuttings available for distribution. The provinces have adopted a similar policy of timber reserves, and the total areas reserved increased from 714,000 ac. in 1901 to nearly 163,000,000 ac. in 1917. These timber reserves are also for the maintenance of water supply and for the protection of wild animals and birds. Canada has always had a large export trade in timber and lumber. The total value of unmanufactured products rose from nearly \$19,000,000 in 1888 to about \$56,300,000 in 1917, and of manufactured products \$71,500,000 to \$146,300,192 in 1918, one factor in the increase being increased value of wood products.

British Columbia stands first in respect of forest organization and scientific administration. It has a well-organized forest service and has initiated special scientific investigations. This work, however, was hindered by the drafts on skilled man-power during the World War. Ontario has undertaken a reorganization of its protective and administrative work. Quebec, following somewhat in the footsteps of France, recognized the necessity for technical training from the first and has a forest school in connexion with Laval University. In New Brunswick similar steps were being taken in 1921.

Table VI. gives an estimate of Canada's stand of timber, mainly coniferous. In the Prairie Provinces the figures may be taken as representing practically all spruce, which in Ontario comprises 100,000,000,000 ft. of the total; in Quebec 150,000,000,000 ft.; in New Brunswick 16,500,000,000 ft., and in Nova Scotia 15,000,000,000 feet. In British Columbia Douglas fir is the dominant timber tree, the rest of the cut being made up of cedar, spruce and one or two minor varieties.

TABLE VI.—Timber, in feet.

British Columbia	366,000,000,000
Prairie Provinces	60,000,000,000
Ontario	160,000,000,000
Quebec	275,000,000,000
New Brunswick	22,000,000,000
Nova Scotia	20,000,000,000
	903,000,000,000

<sup>1</sup> British Columbia is credited with 366,000,000,000 ft. of commercial timber, but her own forestry experts have estimated it at 400,000,000,000 ft. and even as high as 450,000,000,000 ft.

of domestic labour. It was felt that the success of the Soldier Settlement Scheme, which was greater even than had been anticipated, and the wide attention which Canada's agricultural capabilities were attracting in Great Britain and other countries, might do much to relieve the situation. Each province presents its peculiar problems of settlement. In British Columbia, for instance, the opportunities are mainly limited to fruit-growers and those who wish to engage in vegetable and poultry raising and small mixed farming, having live stock always in view. In the Middle West, although the live-stock idea was taking strong root, the prevailing cultivation was in 1921 still wheat, though much attention was being paid by the larger and more progressive farmers to live stock and, so far as possible, to diversified farming. Western Ontario, one of the richest sections of Canada, is devoted to live stock, grain growing, maize, beans, sugar beet, tobacco and fruit. It has the greatest diversity of products, and in addition to a rich soil it has plenty of summer heat, growing tomatoes, peaches and grapes to perfection. Eastern Ontario is less favoured in its climate but rich throughout. Quebec contains much fertile land in the valley of the St. Lawrence, and on account of the habits and instincts of the habitant population is very closely cultivated. The farmers of Quebec are the most contented in Canada. The Maritime Provinces have suffered greatly from emigration to other provinces and to the United States, and a good deal of their useful and once cultivated land is not producing to anything like its capacity. Repopulation and repatriation are among the needs of parts of Ontario and the Maritime Provinces and are among the greatest problems of Government.

The values (in dollars) of various Canadian agricultural products are given in Tables IV. and V.

According to official figures in 1922, the capital invested in the Canadian lumber industry was \$331,263,247; the value of products \$22,648,790, including sawn lumber \$129,041,688. The capital invested in the Canadian pulp and paper industry in 1919 was \$264,581,300; the production of paper having a value of \$91,362,913 and of pulp \$49,566,688.

**Wild Animal Life.**—The establishment by the Government of parks and game and forest reserves or "sanctuaries" is of much importance in connexion with the conservation of the furry animals, the value of which may be gauged by the fact that the exports of Canadian furs of all kinds rose from \$1,569,476 in 1914 to \$13,737,621 in 1919. The constant expansion of the settled area has caused some kinds of fur-bearers to retreat farther into the woods; the clearing of the forests and the grazing of the natural coverts by domestic animals have destroyed their haunts and exposed them to their enemies; and the draining of swampy areas has destroyed the homes of the muskrat or musquash, the mink, the otter and the beaver. The fisher and the marten never seem to survive long near man's habitation. Even the fox, which appears to increase near human settlements, will decrease if the forests are wholly removed or burned. The official policy is to inject new social life, so to speak, into the communities of wild animals, protecting what were left by the fur-hunters, the ruthless sportsmen and the Indians, and preserving and multiplying them under more favourable conditions for future generations. The park reserves for wild animals aggregate 10,000 sq. m. in extent.

Other undertakings on a more expansive scale will probably result from Government investigation and action. The wood buffalo or wild bison may be incorporated with the buffalo herds, and would probably improve the latter. The millions of caribou in the Yukon and adjacent territory and the musk-ox of the barren lands are likely to be nationalized and dealt with like other concessions for the benefit of the nation's meat ladder. Domestic reindeer will be imported, as has been done in Alaska, and a cross with the caribou would probably produce a better variety than either. The mountain sheep is as capable of being domesticated as the reindeer, and the several thousand in existence in isolated flocks in British Columbia and Alberta may become herds. Animals of certain genera become tame when not hunted; this is also true of wild geese, ducks, swans and quail, of which Canada was a wonderful breeding ground. There are further possibilities of dealing with bear, beaver, mink, marten and other animals according to their habits and habitat.

Fur-farming, one of the new industries of Canada, is only a new form of the old and once termed "honourable" business of fur-taking and fur-trading. The difference is that wild animals are now bred and reared in captivity for furs and for breeding stock. In Prince Edward I. fox-farming has made some fortunes, and the sales are included in the agricultural returns of the province; the industry has been extended to New Brunswick, Quebec and British Columbia.

**Fisheries.**—Commenting on Canadian fisheries, an official report points out that: "The fertility of Canadian waters is indicated by the fact that the entire catch of salmon, lobster, herring, mackerel and sardines, nearly all the haddock, and many of the cod, hake, and pollock landed are taken within 10 or 12 m. from shore." The coast-line of the Atlantic provinces from Grand Manan to Labrador, not including lesser bays and indentations, measures over 5,000 m., while the sea-ports to which this forms the certain barrier embrace the Bay of Fundy 8,000 sq. m. in extent; the Gulf of St. Lawrence, fully ten times that size; and other ocean waters aggregating not less than 700,000 sq. m.; a total of over four-fifths of the fishing grounds of the N. Atlantic. In addition there are 15,000 sq. m. of inshore waters owned by the Dominion. Large as are these areas, they represent only a part of the fishing grounds of Canada. Hudson Bay, with a shore 6,000 m. in length, is larger than the Mediterranean; the Pacific coast of the Dominion measures over 7,000 m. long, and is exceptionally well sheltered for fishermen; and throughout the interior is a series of lakes which together cover 220,000 sq. m. or more than one-half the fresh water of the globe, Canada's share of the Great Lakes of the St. Lawrence basin covering 72,700 sq. miles.

The fisheries of the Atlantic are divided into deep-sea and inshore or coastal fisheries. Deep-sea fishing is pursued in vessels of from 40 to 100 tons, carrying crews of from 12 to 30 men. The method is "trawling" by hook and line. The fish taken are principally cod, haddock, hake, pollock and halibut. The inshore fishery is carried on in small boats, usually motor-driven, and in a class of small vessels with crews of from four to seven men. The fisheries of the northern and central provinces have fisheries departments, and these, along with the department of Ottawa, are endeavouring to conserve and develop the fisheries' resources to their utmost extent by means of hatcheries, cultural methods, investigation and restrictive regulations. It is estimated that between 1,000,000,000 and 1,500,000,000 of fish fry of one kind and another are annually planted in various waters from a large number of hatcheries. Long efforts have succeeded in bringing about a treaty to secure international regulations. The Scientific and Research Council has taken up the question of utilizing fish waste. There are over 300,000 tons of fish waste in Canada each year, of which perhaps half could be converted into nitrogenous and phosphate fertilizers and protein foods for cattle, hogs and poultry.

The salmon (product valued at \$15,595,970 in 1920) is obtained almost exclusively on the Pacific coast. Those taken in Quebec, New Brunswick and Nova Scotia resemble those of Great Bri-

tain and are regarded as superior for table use. Only one salmon in British Columbia, the steelhead, may be said to be closely allied to the eastern salmon, and it does not run in large numbers. Cod fishing (\$6,270,171 in 1920) is largely prosecuted on the Atlantic coast and is one of the most useful and valuable of eastern fisheries. The lobster fishing (\$7,152,455 in 1920) has been confined to Nova Scotia, Prince Edward I., New Brunswick and Quebec waters. It is the most extensive in the world, but shows signs of depletion. Herring fishing (\$3,337,738 in 1920) is carried on quite extensively on both coasts. There is in the Great Lakes a fresh-water herring which is becoming popular throughout central Canada. Haddock, hake and pollock are extensively taken in the Atlantic deep-sea fishing. Halibut fishing (\$4,535,188 in 1920) was once a most important industry on the Atlantic seaboard, but its principal headquarters are now at Prince Rupert. Over-fishing is having its effect on the north-west coast and deep-sea fishermen are turning to kinds hitherto neglected. Sardines are abundant in British Columbia and New Brunswick waters, and in the latter province an extensive industry has been established, as in Norway and France, in tinning them. Mackerel are obtained in the Atlantic coast waters. Smelts are very plentiful on both coasts, but particularly in British Columbia waters, where another fish belonging to the salmonidae group, and much resembling it is the oulachon, or candle-fish. The Alaska black cod, when it can be obtained quite fresh or properly cured, is perhaps the most-prized fish on the Pacific coast.

Trout, which are included under a number of names, are taken in all the lakes and rivers from coast to coast, and, while they are not fished for commercially in the same way as other fish, find their way into the market in fair quantities during the season. The whitefish of the Great Lakes and other lakes of the northern interior is among the most valuable of the fresh-water varieties. Pickerel, pike and tullibee are other valuable fish very common in Canadian waters; pickerel is mainly confined to Ontario and Quebec. Other kinds of fish important in the aggregate are—perch, bass, alewives, carp, maskinonge, sturgeon, shad and sole.

Oysters were formerly very abundant on the Atlantic coast, especially in Prince Edward I. waters, whose malpeques were famous, but over-fishing and disease have almost depleted the beds. Whaling is carried on extensively on the Pacific coast, where the industry is concentrated on the west coast of Vancouver Island. In addition to whale oil, fertilizer and whale meat are sold as by-products. Edible clams are distributed widely over both coasts, but especially on the Pacific. According to the official figures, the total output of Canadian fisheries in 1920 was valued at \$49,321,217, as against \$33,103,748 in 1913. The increase was largely due to the increased food-demand caused by the war. Capital to the extent of \$30,334,129 is represented in fish canning and preserving establishments, and \$29,887,734 in vessels, boats, nets, etc., while about 87,070 people in all are employed.

**Minerals.**—In 1906 the value of the total mineral production was \$79,286,202; in 1917 it had risen to \$89,646,821 and in 1920 to \$217,775,080. The Canadian deposits of nickel and asbestos are among the most important in the world, yielding sufficient to control the market in these commodities. The chief mineral productions in 1920 were iron, nickel, gold, cement, copper, asbestos and silver.

The coal reserves of Canada are second in the Empire, amounting to 1,234,000,000 tons, of which over 1,000,000,000 tons are in Alberta and Saskatchewan. Owing to the long stretch between Saskatchewan and Nova Scotia which is coalless, Canada imports from the United States 50% more coal than she produces. This will be remedied, in part at least, if experiments inaugurated and being carried out by the Dominion Government in 1921 are successful. There are vast deposits of lignite in Saskatchewan, too low in grade to be used as fuel in its present form, but which it has been proposed, at the instance of the Industrial Research Council, to carbonize and briquette for commercial use, laboratory tests having demonstrated its high fuel value. There are, too, enormous deposits of peat in the central and other areas of Canada, estimated, if convertible into compressed fuel, as equivalent to 5,000,000,000 tons of coal, and likely to afford many valuable by-products in addition. Experiments on a commercial scale were being carried on by the Government at this end also. Coal represented the largest mineral output in Canada in 1921, the total being valued at \$77,000,000.

Iron occurs in large deposits in British Columbia (northern and central Ontario (especially in the Lake Superior region), in Quebec, Nova Scotia and New Brunswick, and probably also west of Hudson Bay about Great Bear and Slave Lakes, the tonnage already produced being stated in 1920 at over 365,000,000 tons. The fact that 96% of the iron ore smelted in Canadian blast furnaces in 1918 was imported was due to the ore of all accessible large deposits requiring special treatment ("beneficiation") before being charged to the furnace; there were two large beneficiary plants for this purpose in Ontario, but more such plants were needed before the iron-ore mining could attain its proper importance. Canada had nine blast furnaces with an aggregate daily capacity of 3,782 tons, and yet she imported in 1919 over 2,000,000 tons of ore. The Nova Scotia blast furnaces are fed from Newfoundland, and Ontario furnaces mainly from the iron-mines of the United States Lake Superior region.

The placer deposits of British Columbia were formerly the principal supply of gold in Canada, but had seriously declined in

production when the Yukon came suddenly into prominence in 1897 as a new source of supply. Then Porcupine loomed on the horizon as a rich producer, and Ontario as a consequence in 1920 yielded half the total production, viz. \$1,665,735. Manitoba has become a small producer, the gold being derived from the newly opened region north of the Pas. Nova Scotia and Quebec have been small but steady producers for years. There are inviting prospects for gold over large areas of northern Ontario, northern Quebec, northern Manitoba and Saskatchewan, and throughout British Columbia.

In 1890 and 1891 rich discoveries in silver were made in the Stocan district of British Columbia, the silver being found associated with lead in galena ores. The province has since been a large producer both of silver and lead, and now also of zinc, which is usually a concomitant of lead and silver in the Kootenay silver-lead ores. In 1903, however, deposits were discovered in northern Ontario about 100 m. north-east of Sudbury, in what is now known as Cobalt, which proved to be marvellously rich in silver, so much so that in 1911 the production there was over \$30,500,000. The Thunder Bay region west of Port Arthur yielded silver as far back as 1846, and attention is again being directed to the old mines.

Despite the fact that for a number of years Government bounties were paid on lead and zinc mined and smelted in Canada, the output of these metals did not increase, except during the war, when the demand for lead eliminated the bounties automatically, and new processes made the extraction of zinc practicable. Nearly all the production in both metals is in British Columbia, although Quebec and Ontario contribute small amounts. There are notable deposits in several parts of Ontario, in the Gaspé Peninsula, Quebec, and in northern New Brunswick.

Copper is widely distributed throughout Canada and where found is usually in large bodies. Of nearly 110,000,000 lb. produced in Canada in 1917, British Columbia contributed well over one-half, Ontario came next with about 43,000,000 lb., drawn mainly from the Sudbury district, and Quebec third with over 5,000,000 lb. The new district of the Pas gave over 2,000,000 lb. and the Yukon about 300,000 lb. Depending upon the future demands for copper, the possibilities of Canada in British Columbia, in the Yukon, in the extreme north of Canada, in northern Ontario and in Quebec, including Ungava, are without doubt very great.

Sudbury district in Ontario, which is characterized by the richness and diversity of its minerals, is the chief source of nickel. Twenty large companies are in operation and have constructed refineries; their investments representing between \$15,000,000 and \$20,000,000. New Caledonia, lying about 1,000 m. east of Australia, is the only serious competitor to Canada in nickel production. Among the other metals whose ores are mined in Canada are molybdenum and antimony, very widely distributed, but of which very few payable deposits are known. Platinum occurs in the placer deposits of Quebec and British Columbia, and prospecting is active.

The total mineral production (metallic and non-metallic) of Canada in 1920 was valued at \$102,353,862, including the following items: coal, \$77,326,853; nickel, \$21,854,597; gold, \$15,853,478. copper, \$14,166,479; asbestos, \$13,677,841; silver, \$12,908,683; zinc, \$3,081,149; lead, \$3,038,346; pig-iron, \$2,066,997. The output of structural materials and clay products was valued at \$38,184,848.

**Water-Power.**—The officials of the Dominion Water-power Branch, Department of the Interior, have made a careful re-analysis of the water-power resources, which are one of the Dominion's greatest natural assets. The figures in Table VII. are based upon rapids, falls and power sites, of which the actual existent drop or the head possible of concentration is definitely known or at least well established. Innumerable rapids and falls of greater or lesser power capacity not as yet recorded are scattered on rivers and streams from coast to coast, particularly in the great northern country, much of which is still practically unexplored. The power estimates have been calculated for 24-hour power at 80% efficiency on the basis of "ordinary minimum flow" and "estimated flow for maximum development." The former is derived from the averages of the minimum flow for the lowest two consecutive seven-day periods in each year, over the period for which records are available, and the latter from the continuous power indicated by the flow of the stream for six months in the year. As will be seen from the table, the recorded power available throughout the Dominion is 18,255,000 H.P. The water-power available under estimated flow for maximum development, that is, dependable for at least six months in the year, is 32,076,000 H.P.

There are installed throughout the Dominion water-wheels and turbines to the extent of 2,471,000 H.P. An analysis of the water-power plants scattered from coast to coast gives an average machine installation 30% greater than the six-month flow maximum power. Applying this, the figures indicate that the water-power resources recorded in 1920 permit of a turbine installation of 41,700,000 H.P. In other words, turbine installations represented in 1920 only 5.9% of the recorded water-power resources. Though industrial and commercial conditions were still far from normal, in 1920 there was installed, or under construction, plant of 500,000 H.P. capacity. This figure, however, includes only initial installation, not ultimate designed capacity. Should the rate of water-wheel installation during the previous 15 years be continued, it was estimated that in 1940 Canada would have 5,600,000 H.P. developed water-power.

TABLE VII.—Water-Power.

Province	Available 24-hour power at 80% efficiency.		Turbine Installation H.P.
	At ordinary min. flow H.P.	At est. flow for max. dev. (dependable for 6 mos.) H.P.	
British Columbia	1,931,142	5,103,460	304,533
Alberta	475,281	1,137,505	38,492
Saskatchewan	513,481	1,087,750	—
Manitoba	3,270,491	8,709,444	83,447
Ontario	4,950,300	6,808,190	1,052,048
Quebec	6,915,444	11,640,052	925,972
New Brunswick	50,406	120,807	21,180
Nova Scotia	20,751	128,264	35,774
Prince Edward I.	3,000	5,270	1,933
Yukon & North-west Territories	125,220	375,250	13,199
	18,255,316	32,075,998	2,470,580

Canada exports annually about 200,000 H.P. to the United States. The export takes place from New Brunswick to Maine, from Quebec to New York state, from Ontario to New York and Minnesota, and from British Columbia to the state of Washington.

**Manufactures.**—The increase in the industries of Canada during the period 1910-21 was very remarkable. War activities and increased prices accounted to a considerable extent for increased volume of production and value of output. In 1921 industry in all branches showed the decline in output which was almost universal on account of lack of foreign demand and industrial disputes. The capital employed was \$1,247,583,699 in 1910, and \$3,034,301,915 in 1918; and the value of product \$1,165,975,639 in 1910 and \$3,458,036,975 in 1918.

The principal industries, with the value of products in 1918, were officially as follows: Flour and grist-mill products, \$262,537,122; slaughtering and meat-packing, \$229,231,666; rolling-mills and steel furnaces, \$209,706,349; munitions, \$186,034,920; lumber, lath and shingles, \$146,333,192; pulp and paper, \$119,309,434; butter and cheese, \$94,927,032; foundry and machine-shop products, \$82,493,897; shipbuilding and repairs, \$74,799,411; cottons, \$66,399,228; cars and car works, \$66,068,705; smelting, \$62,482,256; houses and building, \$60,522,151; sugar-refining, \$58,812,219; electric light and power, \$53,449,133; boots and shoes, \$46,387,665; hosiery and knit goods, \$45,755,129; plumbing and tin-smithing, \$41,870,529; car repairs, \$40,592,617; drugs and chemicals, \$38,252,571; tobacco, \$37,883,974; agricultural implements, \$34,853,673; fish-preserving, \$34,007,628; men's clothing, \$33,835,793; leather, \$33,273,925; women's clothing, \$32,346,340; printing and publishing, \$30,325,123; electrical apparatus and supplies, \$30,045,399; boilers and engines, \$29,470,457; lumber products, \$29,125,925.

**Trade.**—The great expansion of trade during 1910-21 is shown in Table VIII., which gives the value of imports and exports.

TABLE VIII.—Imports and Exports.

	Imports	Exports
1911	\$ 457,724,603	\$ 290,000,210
1912	522,404,675	307,776,151
1913	671,207,234	377,068,355
1914	619,193,908	455,437,224
1915	455,953,908	461,442,599
1916	508,201,134	779,300,070
1917	846,450,878	1,179,211,100
1918	963,532,578	1,586,169,792
1919	919,711,705	1,268,765,285
1920	1,064,528,123	1,286,658,709

The principal customers were the United Kingdom and the United States. Table IX. gives the values of Canada's imports from, and exports to, the United States; and Table X. Canada's imports from, and exports to, the United Kingdom.

TABLE IX.—Trade with United States.

	Imports	Exports
1911	\$75,824,265	\$112,808,676
1912	331,384,657	112,956,395
1913	436,887,375	150,961,673
1914	356,308,138	176,948,299
1915	297,142,059	186,322,356
1916	370,880,549	16,660,262
1917	665,312,739	290,578,773
1918	792,894,957	440,811,400
1919	750,803,024	477,695,628
1920	801,097,318	301,136,217

TABLE X.—Trade with United Kingdom,

	Imports	Exports
1911	\$109,934,753	\$136,962,971
1912	116,906,360	151,833,379
1913	138,742,644	177,982,002
1914	132,072,496	222,522,292
1915	90,157,204	211,757,218
1916	77,464,361	463,081,241
1917	107,096,735	758,071,059
1918	81,324,283	861,073,399
1919	73,035,118	560,839,116
1920	126,362,631	495,960,118

**Railways.**—The Canadian railways in 1921 had become consolidated into two great systems, the Canadian Pacific and the National railways. In 1918 there were 38,875 m. in operation, over 20,000 of which were under Government control. The capitalization of railways in operation at the end of 1918 was \$1,098,830,494, and the aggregate earnings for the year were \$330,220,150. There are six canal systems under the control of the Dominion Government.

As a result of the war the railway situation had changed very materially from one of optimism in 1912-3 to one of almost painful anxiety in 1919. This arose from the inability of the Canadian Northern on the one hand to sell its bonds to complete its transcontinental system, and of the Grand Trunk, on the other, to meet its interest and other obligations in connexion with the Grand Trunk Pacific, and to cope with the increased working-costs arising out of war conditions. Repeated appeals were made to Parliament for further financial aid. A Royal Commission, consisting of three eminent railway experts, was appointed to inquire into the entire railway situation of Canada, and after an exhaustive investigation there was issued what was known as the Acworth-Drayton (majority) report, practically recommending that the Canadian Northern should be taken over by the nation, amalgamated with the national railway system and operated under a council of a board of directors. A system which would apply if and when the Grand Trunk and Grand Trunk Pacific were taken over was also recommended. The nationalization of the Canadian Pacific was not recommended. The recommendations of the majority report of this commission became the policy of the Government, and on June 30 1918 the Canadian National ceased to be an independent entity. In the legislation of 1917 authorizing acquisition provision was made for acquiring the balance of capital stock, amounting to \$60,000,000, not in the hands of the Government, its value to be determined by arbitration. This was fixed at \$10,800,000, and the transfer was made. The system is now operated by a board of directors, of which in 1921 Mr. D. B. Hanna was president. The Grand Trunk, meanwhile, desired to be relieved of its obligations in connexion with the Grand Trunk Pacific and National Transcontinental. In the spring of 1918 the Grand Trunk Pacific notified the Government that it would not be possible for the company to continue its operations when the balance of money in hand had been exhausted (about March 10), and authority was immediately taken by Order in Council under the provisions of the War Measures Act to appoint a receiver for the company, Parliament having confirmed this action. In the fall session of Parliament a bill was introduced and passed authorizing the acquisition of all the capital stock of the Grand Trunk system, the Government, however, guaranteeing 4% dividends as well as interest upon present debenture stock outstanding. The value of the preference and common stocks (up to a maximum of \$2,500,000) was to be determined by a board of three arbitrators, and a committee of management was to be formed—two members to be appointed by the Government, two by the Grand Trunk and a fifth by the four so appointed—to ensure as far as possible the operation of the railway in harmony with the Canadian National system. This went into effect. Not without some difficulty the consent of the Grand Trunk shareholders was obtained and arbitrators agreed to. Sir Thomas White, late Minister of Finance, acted for the Government; Mr. Wm. H. Taft, ex-President, and later Chief Justice of the Supreme Court, of the United States, acted for the Grand Trunk; Mr. Justice Walter Cassels, Ottawa, was chairman of the board. In September 1921 their awards were published. The two Canadian arbitrators held that "no value" attached to the common and preference stocks, though it would be for the Government to decide whether it should go outside the sphere of the arbitrators in granting *ex gratia* compensation. In a dissenting judgment, Mr. Taft held that their "value" was higher than the maximum provided in the Act.

It was further contemplated that all the railways built or acquired by the Government would eventually be amalgamated into one large system, operated by a National Board of Directorate. During the several sessions in which the legislation referred to was brought about very keen and protracted discussion, involving largely the principle of Government ownership, took place. The opposition was greatly emphasized by announcements of increasing deficits in the operation of the National system in 1920-1, the amount being, it was stated, \$68,000,000. Five steam railways paid dividends during 1919: the Canadian Pacific \$29,277,477, and four others in the aggregate \$761,000. The average number of miles operated in

March 1921 was 38,076.10. The Canadian Pacific and the National railways (including the Grand Trunk) operated over 85% of the total single-track mileage, as follows: Canadian Pacific 13,755 m.; Government railways (under jurisdiction Department of Railways) 4,564 m.; Canadian National (under board of directors) 9,757 m.; Grand Trunk Pacific (under receiver) 2,807 m.; Grand Trunk 3,577 m. The total mileage of Government roads in Canada was in 1921 20,699. The mileage of independent railways was: Algoma Central 347; Algoma Eastern 89; Quebec Central 277; Victoria, Vancouver & Eastern (Great Northern) 269; Kettle Valley (Canadian Pacific) 355; Pere Marquette 199; Canada Southern (Michigan Central) 380; Dominion Atlantic (Canadian Pacific) 274; Great Waterways (Province of Alberta) 113; Edmonton, Dunvegan & British Columbia (Alberta Government, operated by C.P.) 406 miles.

The total capitalization of steam railways on Jan. 1 1921 was \$2,036,165,660, of which \$568,606,803 belonged to the Canadian Pacific, \$451,685,996 to the Grand Trunk, \$1,792,087 to the Canadian National, \$413,590,078 (capital expenditure) to the Canadian Government railways (including National Transcontinental & Hudson Bay railway), and \$216,512,550 to Grand Trunk Pacific and branch lines. Salaries and wages amounted to \$233,323,074 and the number of employees to 173,728. There was a total corporate loss on operation for the year of \$15,977,747. The track mileage of electric railways amounted to 2,400 miles. Capital stocks outstanding and funded debt of these amounted to \$173,041,340, and \$20,211,576 wages were paid to 16,940 employees.

**Canals.**—The river St. Lawrence, with the canals established on its course above Montreal, and the lakes Ontario, Erie, St. Clair, Huron and Superior, with connecting canals, afford a course of water communication extending from Montreal to Port Arthur, at the head of Lake Superior, a distance of 1,214 miles. The distance to Duluth is 1,336 m. and to Chicago 1,242 m. This through system comprises 74 m. of canal with 48 locks, the remainder of the distance consisting of river and lake waters. The minimum depth of water on this route is 14 feet. The canal approaches and the channels of the intermediate river reaches are well defined, and are lighted with gas buoys, admitting of navigation by night as well as by day. The Lachine, Soulange, Cornwall, Welland and Sault Ste. Marie canals are lighted throughout by electricity, and are electrically operated.

In view of the agreement signed by the members of the International Waterways Commission, it may be noted that the St. Lawrence river is the greatest waterway in the world and the oldest. In use in the New World. There are no floods in the St. Lawrence as in the Mississippi, the Columbia or other large rivers of the continent. The difference between maximum and minimum volume is 119 ft., as compared with the Ohio, 28.22 ft.; the Missouri, 95 ft.; and the Mississippi, 10.29 ft. The lakes act as settling basins and no silt is carried down to be deposited in the river. Hence when a channel is dredged, the dredging process does not require to be continuous as in most other rivers. Between Montreal and Quebec the river was deepened some years ago to 30 ft. and work is in progress to increase it to 35 ft., so that the largest ocean vessels may dock at Montreal. Canals have been built at various times to overcome the rapids between Lake Ontario and Montreal, and six of these, varying in length from 0.75 to 14 m., in width from 144 to 146 ft., and in depth from 14 to 15 ft., are in existence. To make the waterways scheme feasible, this section of the river would have to be so improved as to admit the passage of ocean vessels. The Welland Canal, which was being rebuilt between Port Colborne on Lake Erie and Port Water on Lake Ontario in 1921, will be 80 ft. wide and 30 ft. deep. It will be able to accommodate ocean vessels and will form the key of the entire scheme of oceanizing the international waters of Canada, if that should be decided upon. Locks on the "500 Canal" have opened Lake Superior to the world, and improvements from Lake Superior to Detroit have been made to render navigation on the proposed scale practicable. Incidentally the scheme involves the development of water-power estimated at 2,000,000 H.P.

Of the minor systems, the Murray, Trent, Rideau and Ottawa river canals may be considered as branches of the through east-to-west route. In operation, however, these canals serve a distinct traffic of a more local nature. Isolated from the system of through navigation, the navigation of the Richelieu river, from its junction at Sorel to Lake Champlain, is effected by means of the St. Ours lock and the Chambly Canal, while to the extreme east the St. Peter's Canal provides communication between St. Peter's Bay, in Cape Breton, Nova Scotia, with the Bras d'Or lakes. It crosses an isthmus half a mile in width, and gives access to the Atlantic. A ship canal was in course of construction from Port Dalhousie to Port Colborne, connecting Lake Ontario and Lake Erie; work was suspended on account of war conditions. Among projected works may be mentioned what is known as the Georgian Bay Canal, to connect the Ottawa river with Georgian Bay. Some years ago the Government engineers surveyed the route, and reported that a waterway with a depth of 20 ft. could be provided at a cost of about \$100,000,000. By this route the distance from Fort William to Montreal would be 934 m., as against 1,217 by the present route, and Montreal and Chicago would be brought within 972 m. of each other, as compared with 1,242 by the present route.

**Roads.**—At the end of 1920 about 250,000 m. of public highways in Canada were open and serviceable for ordinary travel during the

summer season. The roads are graded and crowned, with suitable drainage, culverts and bridges. The mileage in the nine provinces is fairly evenly distributed, in accordance with area and population. In five of them the roads have been made and maintained at the expense of the Provincial Governments; in the other four the cost has been borne by the municipalities and Provincial Governments in co-operation. During recent years there has been a very large increase in the number of automobiles using the roads, and for this reason a harder and smoother road surfacing has been necessary. All road work on main roads is done on approved high standards, with hard finished surfaces consisting of gravel and stone macadam, cement concrete, asphaltic surfacing.—In every instance asphaltic or some bituminous surfacing or oil treatment. To assist the provinces and municipalities in this respect, the Dominion has passed legislation by which it is empowered to furnish aid to the extent of 40% of the cost of high-class improvement upon main highways. The amount devoted to this purpose is \$20,000,000, to be spread over a period of five years, the aid to be given, in any case, being 40% of the amount which is the actual, necessary and reasonable cost of the construction or improvement of such highway. The conditions attached to the grant are that any construction or improvement shall be in accordance with the terms of an agreement to be made by the Minister of Railways and Canals of Canada with the Provincial Government and that the agreement shall contain such provisions as to location, cost, description, specifications, etc., as are necessary to protect the public interest, all expenditure being by tender and contract.

**Finance.**—The Canadian Bank Act contains no specific provisions as to the amount of gold to be held either against note circulation or the general business of the bank. It requires, however, that 40% of whatever reserve the bank finds expedient to carry shall be in Dominion notes. A second provision instructs the Minister of Finance to arrange for the delivery of Dominion notes to any banks in exchange for specie. Thus the gold reserve against Dominion notes, to the extent that the notes are held by the banks, is a reserve against banking operations, the Dominion Government being the custodian of the gold for the banks. The other gold element in bank reserves is specie in hand. The sum of the two represents the gold basis of the Canadian banking system. In addition to the reserves above mentioned the Canadian banks carry three other kinds of assets which are regarded as reserves, being funds more or less immediately available for the liquidation of liabilities. In 1906 there were 34 chartered banks with branches numbering 1,565. Since that time there has been very considerable consolidation. In 1921 the number of banks was 18, but the number of branches had more than doubled, being now in various provinces 3,440. The banks are required by law to furnish to the Minister of Finance detailed monthly statements which are published in the official gazette. Clearing-houses have been established in the chief commercial centres and cover the operations of Canada as a whole. On Dec. 31 1919 the paid-up capital of the banks was \$119,199,441, with a note circulation of \$232,486,734 and total deposits amounting to \$1,841,478,895. The total liabilities at that time amounted to \$2,495,582,568 and total assets \$2,754,568,118. At the end of 1919 the total amount to the credit of depositors in the Post Office and Dominion Government savings banks was \$53,057,018. The amount on deposit in the savings departments of the chartered banks was \$1,125,202,403.

The Dominion revenue and expenditure in 1914-20 are shown in Table XI. Up to March 31 1920 the total outlay for the war was approximately \$1,670,406,342. This amount includes all expenditures in Canada, Great Britain and France, and is also inclusive of the upkeep of the troops overseas.

TABLE XI.—Revenue and Expenditure: March 31 1914—March 31 1920.

	Revenue	Expenditure—Consolidated Fund
1914-5 . . . . .	\$133,073,481	\$135,523,206
1915-6 . . . . .	129,147,838	139,359,726
1916-7 . . . . .	232,701,294	148,599,343
1917-8 . . . . .	260,778,953	178,284,313
1918-9 . . . . .	312,946,747	232,731,282
1919-20 . . . . .	349,746,334	303,843,929

	Expenditure—Capital Account	Expenditure—War Accounts
1914-5 . . . . .	\$41,447,320	\$ 60,750,476
1915-6 . . . . .	38,566,950	166,197,755
1916-7 . . . . .	26,880,031	306,488,814
1917-8 . . . . .	43,111,904	343,836,802
1918-9 . . . . .	25,031,266	446,519,439
1919-20 . . . . .	69,301,877	345,616,954

The net debt of Canada, which before the war stood at about \$363,000,000, on March 31 1920 was \$2,248,868,623. The increase was almost entirely attributable to war expenditure. Details of the domestic loans issued by the Canadian Government since the commencement of the war are given in Table XII. In addition War Savings Certificates to the amount of approximately \$12,500,000, as well as a considerable amount of debenture stock, were

sold. Loans were also floated in New York for: (1918) \$274,000, (1916) \$75,000,000, (1919) \$15,000,000, (1919) \$60,000,000. From the outbreak of war to Nov. 30 1918 Canada established huge credits on behalf of the Imperial Government. Through these advances Great Britain and her Allies were able to finance the purchase of food-stuffs, hay and other commodities and to carry on the operations of the Imperial Munitions Board in Canada. In addition to the above, Canadian chartered banks advanced to the Imperial Government through the medium of the Minister of Finance the sum of \$200,000,000 for the purchase of munitions and wheat. This was made possible by the large savings deposits in Canadian banks, which from Aug. 1914 to Oct. 31 1918, despite the withdrawals for subscription to war loans, increased by \$417,115,476.

TABLE XII.—Internal Loans.

	Allotment	No. of Subscribers
1915-25 5% . . . . .	\$100,000,000	24,862
1916-31 5% . . . . .	106,705,000	34,526
1917-37 5% . . . . .	172,926,800	41,263
1917-37 (Victory Loan) 5% . . . . .	546,148,750	809,000
1918 (2nd Victory Loan) 5% . . . . .	682,256,300	1,100,000
1919 (3rd Victory Loan) 5% . . . . .	\$24,725,200	800,000

Soon after the outbreak of war taxes were placed on luxuries and gradually increased. Higher customs duties and rates of excise on certain commodities, including liquors and tobacco, imposed soon after the commencement of the war, were followed in 1915 by a war tax on transportation tickets, telegrams, money orders, cheques, letters, patent medicine, etc. In 1915 an increase of 7% *ad valorem* to the general tariff and 5% *ad valorem* to the British preferential tariff was made on all commodities with the exception of certain food-stuffs, coal, harvesting machinery, fisheries, equipment, etc. In 1918 a special customs duty was imposed on tea and coffee and the excise on tobacco was increased. In addition, various other taxes were imposed or increased, and a special war excise tax was imposed on various articles, including automobiles, jewelry, etc. Under the Business Profits War-Tax Act the Government at one time, in the case of all businesses having a capital of \$50,000 and over, took 25% of the net profits over 7% and not exceeding 15%, 50% of the profits over 15% and not exceeding 20%, and 75% of the profits beyond 20%. In the case of businesses having a capital of \$25,000 and under \$50,000 the Government took 25% of all profits in excess of 10% on the capital employed. Companies employing capital of less than \$25,000 were exempted, with the exception of those dealing in munitions or war supplies.

The Canadian income-tax, which came into effect in the year 1918-9, is in some respects higher than that in force in the United States. The scale provides for the exemption of incomes in the case of unmarried persons with an income of \$1,000 and under, and in the case of married persons with an income of \$2,000 and under. There is also provision for the exemption of \$300 for each child.

**Defence.**—Under the Militia Act of 1904 the command in chief of the militia is vested in the king, by whom, or by the governor-general as his representative, it is exercised and administered. The Act further provides for the appointment of a Minister of Militia and Defence, charged with the administration of militia affairs, and of a deputy minister; also for the appointment of a militia council. This includes, besides the minister and deputy minister, four military members—the chief of the general staff, the adjutant-general, the quartermaster-general, and the master-general of the ordnance. There is also an inspector-general, whose duty it is to inspect the forces and report to the minister on their readiness for war, but he has no seat in council. The Canadian land forces are divided into the active militia and the reserve militia. The active militia consists of a permanent and a non-permanent force, the latter divided into city and rural corps. Service in the active militia is voluntary and for three years, but the Government has the power to apply compulsion should the necessity arise. The permanent force comprises all arms of the service and is composed of a number of permanently embodied units. It provides personnel for the various schools of military instruction and garrisons for the fortresses, where a permanent element is necessary for defence, for the maintenance of works and for the preservation of armaments. The non-permanent active militia undergoes an annual period of training, which varies from 12 to 16 days according to the arms of the service and the location of the corps, *i.e.* whether they are city or rural. The reserve militia has not been organized. The authorized Limited Establishment for the permanent force was approximately 4,000 in 1921. The non-permanent active militia is comprised of such corps as from time to time are authorized by the governor-general in council. In pre-war days its strength was approximately 68,000.

The above organizations are supplemented by numerous cadet corps and rifle associations. The Royal Military College at Kingston provides both a military and a general education. It trains officers both for the permanent force and for the remainder of the active

militia, and a certain number of commissions in the British regular army are granted annually to its cadets.

**Naval Service.**—The department of the Naval Service of Canada embraces, in addition to the naval service proper, fishery protection, hydrographic surveys, tidal and current survey, radiotelegraph or wireless service and the Canadian Arctic Expedition. The naval service proper embraces one light cruiser, two torpedo destroyers and two submarines, a gift from the Admiralty of Great Britain. It also embraces the Royal Naval College of Canada and the dockyard at Esquimaux and the dockyard at Halifax. The dockyards at Esquimaux and Halifax are maintained as bases of supply and for the purpose of repair and overhaul of the ships of the fleet, as well as for the other services of the department. The principal functions of the department are thus: (a) to assist in the maritime defence of the Empire; (b) the maritime defence of Canada from attack from overseas; (c) the protection of Canadian fisheries; (d) the surveying of ocean beds, coast-lines, bays, rivers and lakes, and the preparation and distribution of charts, plans and sailing directions of the navigable waters; (e) the scientific investigation of tides and currents, and the prediction and determination of tide levels; (f) the administration of wireless telegraphy and telephony throughout the Dominion; (g) the completion of the Canadian Arctic Expedition.

**HISTORY.**—The political history of Canada in 1910-13 centred round the two great questions of Reciprocity with the United States and Canadian naval policy in relation to the Empire. On July 18 1911 Parliament reassembled after the Coronation adjournment, and on July 29 the Government of Sir Wilfrid Laurier, who had been Premier since 1896, decided to recommend the dissolution of Parliament and to submit their proposals for commercial reciprocity with the United States to the judgment of the Canadian people at a general election, which was fixed for Sept. 21. While the chief question before the electors was the Reciprocity Agreement, the question of Canada's naval policy received much attention, especially in the province of Quebec. The result was a complete defeat for the Government and the Reciprocity party. What had been a Liberal majority of 43 was converted into a Conservative-Liberal and anti-Reciprocity majority of 49. Mr. Fielding and Mr. Paterson, who were responsible for the negotiations with the United States, were both defeated, together with Sir F. Borden and four other ministers. On Oct. 6 Sir Wilfrid Laurier and his administration resigned office. Sir Wilfrid Laurier retained his seat, however, and decided to remain at the head of his party, now in Opposition.

Mr. (later Sir) R. L. Borden (b. 1854), leader of the Conservative party, being called upon to form an administration, accomplished this task on Oct. 10 1911, and the new Ministry was constituted as follows: R. L. Borden, Premier and President of the Privy Council; George Eulas Foster (b. 1847), Trade and Commerce; Robert Rogers (b. 1864), Interior; F. D. Monk (b. 1856), Public Works; Francis Cochrane (b. 1852), Railways and Canals; William T. White (b. 1866), Finance; Louis P. Pelletier (b. 1857), Postmaster-General; John D. Hazen (b. 1860), Marine and Fisheries and Naval Service; Charles J. Doherty (b. 1855), Justice; Samuel Hughes (b. 1853), Militia and Defence; William J. Roche (b. 1850), Secretary of State; Thomas W. Crothers (b. 1850), Labour; Wilfrid B. Nantel (b. 1857), Inland Revenue and Mines; John D. Reid (b. 1850), Customs; Martin Buxton (b. 1858), Agriculture; George H. Perley (b. 1857), Albert E. Kemp (b. 1858), and James A. Lougheed (b. 1854), members without portfolios. On Oct. 22 1912 Mr. Monk resigned on the question of Mr. Borden's naval policy and his portfolio was taken over by Mr. Rogers, Mr. W. J. Roche becoming Minister of the Interior in his place. The office of Secretary of State was filled by Mr. Louis Coderre (b. 1865), the member for the Hochelaga division of Montreal. On Oct. 23 1911 the Hon. Auguste Landry was appointed Speaker of the Senate, and on Nov. 15 Dr. T. S. Sprague was elected Speaker of the House of Commons.

The twelfth Parliament of the Dominion of Canada was opened on Nov. 15 1911 by the new governor-general, the Duke of Connaught, in person. The address in reply to the speech from the throne was voted on Nov. 29, and on Dec. 7 Parliament adjourned over the Christmas recess until Jan. 10 1912. On re-assembling, the main business was financial. On April 1 1912 Parliament was prorogued.

When the new session opened on Nov. 21 1912, it was known that the announcement of Mr. Borden's naval programme would

be the business of outstanding importance. The governor-general, in the speech from the throne, stated that his advisers having consulted with the Imperial Government, it had been concluded that it would be the duty of Canada at this juncture to afford aid in strengthening the effective naval forces of the Empire; and on Dec. 5 the Premier announced an Emergency Contribution bill, leaving permanent policy for future consideration.

**The Reciprocity Question.**—Sir W. Laurier's Government had begun their official negotiations for Reciprocity with the United States in Jan. 1911, as the result of private discussions in the previous year. The terms of the proposed agreement were announced in the Canadian Parliament by Mr. W. S. Fielding, the Finance Minister in Sir W. Laurier's Cabinet, on Jan. 26 1911. It aimed at more free interchange of products by removing duties on certain articles and reducing them in others.

Among those which were to enter free in each country, if of the growth, product or manufactures of the other, were live animals, poultry, wheat and other grain, vegetables, fruit, dairy products, honey, cottonseed oil and certain oil seeds, grass, garden, field and other seed, fish, except those preserved in oil, certain fish oils, timber (not sawn), brass (not polished), rolled iron or steel sheets 14-gauge or thinner, galvanized, coated with zinc or tin, crucible cast steel, galvanized iron, steel or wire, typewriting and typesetting machines, barbed wire fencing, coke (round), wire rods, wood pulp, and cream separators. Among the articles to be admitted into Canada from the United States and into the United States from Canada at identical rates were the following: Fresh meats 1½ cents per lb.; bacon and hams, not in tins or jars, 1½ cents per lb.; meats dried and preserved 1½ cents per lb.; canned meats and poultry 20%; lards, etc., 1½ cents per lb.; barley, malt, per 100 lb. 45 cents; cereal foods 12½ cents per 100 lb.; biscuits, wafers, cakes 25%; confectionery 32½%; farm wagons 22½%; farming implements of various kinds 15%; portable engines with boilers and traction engines for farm purposes 20%; roofing slates 55 cents per 100 ft.; cutlery, plated or not 27½%; clocks, watches, etc., 27½%; automobiles 30%. Arrangements were made for special rates of duty on a moderate scale to cover a large number of other commodities.

The case presented for the adoption of this agreement was that reciprocal trade relations had been the policy of all parties in Canada for generations, that many efforts had been made to secure a treaty without success, and that Sir John Macdonald's National Tariff policy (1879) contained a standing offer of reciprocity with the United States covering a large portion of the products included in the present agreement. The United States having approached Canada with fair offers, it was claimed that they should be fairly met, and that in making the arrangement the Government were realizing the desires which the Canadian people had expressed for half a century, and also that in promoting friendly relations with the neighbouring republic the best possible service to the Empire was being done. As Canada was seeking markets everywhere for her surplus products, subsidizing steamship lines, and sending out commercial agents, it would be absurd to refuse increased facilities at her very doors if they could be obtained by negotiation.

A denial was given to the expressed fear that the imports from Great Britain would be seriously affected. It was pointed out that the greater part of the agreement dealt with natural products which did not come from Great Britain, and that the range of manufactures affected was small. It was further denied that there was any foundation for the assumption that the tariff rates agreed upon discriminated in favour of the United States and against Great Britain. The promoters of the agreement promised that in every case Great Britain would have the same rate or a lower one, and held that Canada's right to deal with the British preference as she pleased remained untouched.

The opposition to the agreement took the ground that the arrangement had been entered into hastily without its effects being fully appreciated, and that the question should be referred to the people. Attention was drawn to the success which had attended the efforts to build up a nation and bind the country together from east to west, and it was contended that, as the arrangements proposed would primarily affect the question of transportation by promoting a tendency to make trade move north and south, the immense efforts which had been made would be sacrificed, and the markets which had been secured in Great



Britain abandoned. The action of the United States in approaching Canada with a desire to make such an agreement, after declining on so many occasions to consider the question when asked to do so by Canada, was looked upon with suspicion, and it was suggested that the balance of advantage would remain with the United States, the speeches of some of her most prominent public men being freely quoted in support of this view—notably one by Mr. Champ Clark in Congress, and another by President Taft himself. It was held that the impelling cause was the desire of the United States to have access to the abundant natural resources of Canada, her own reserves of wood, coal and other minerals, and much of her farm land, having shown signs of exhaustion. It was thought the better plan was to conserve Canadian resources for Canadian use. A further objection to the proposals was that, while they would change the whole current of Canadian industries, and be likely to dislocate the national development, the new markets proposed would be so entirely unstable and insecure that, after having had the benefit of them for a few years, they might be withdrawn, causing a reversion to the position of 25 years earlier, and necessitating the rebuilding of home industries and re-making their reputation in markets which in the meantime had been entirely occupied by old competitors. Great importance was attached to the restriction on legislation which it was alleged this agreement would cause, as no trade aggrieved under it could obtain redress without the arrangement as a whole being upset. It was also urged that under its concessions in the tariff would have to be made, in accordance with existing treaties, to countries from which no equivalent advantages could be obtained; and it was declared that if this Reciprocity policy was pursued the ties of Empire would eventually be cut, for it would lead to complete commercial union and in the end the political domination of the United States, to which Canada would simply be an annexe.

The debates in connexion with the matter lasted for almost the remainder of the session; but on Feb. 22 1911, on the motion of Mr. F. D. Monk, the House adopted unanimously the following as an amendment to the motion for going into Committee of Ways and Means: "But, before resuming the discussion of the terms of the agreement concluded between the Government of Canada and the President of the United States, and with a view to dispel the feeling of unrest created in Canada by comments made in both countries as to the political consequence of the agreement, the House wishes to affirm emphatically its determination to preserve intact the bonds which unite Canada to the British Empire and the full liberty of Canada to control her fiscal policy and internal autonomy."

A bill to give effect to this Reciprocity Agreement on the part of the United States was introduced in the American Congress on Jan. 29, and in due course passed the Senate on July 22, it being enacted that its provisions should become operative as soon as the necessary counterpart legislation had been passed by the Canadian Parliament. Discussion continued in the Canadian House of Commons, but no progress was made towards the adoption of the proposals, and on July 29 1911 the Government decided to recommend the dissolution of Parliament and to submit the matter to the judgment of the people at a general election. The defeat of the Government followed, the result being greatly influenced by the strong opposition to Reciprocity which was shown by such well-known Liberals as Mr. Clifford Sifton (b. 1861; formerly Minister of the Interior in the Laurier Cabinet), Mr. Lloyd Harris and Mr. Wm. German, and by the steps taken by a body of prominent Liberals of Toronto, assisted by Sir Edmund Walker, president of the Canadian Bank of Commerce.

*Sir W. Laurier's Naval Policy.*—An outcome of the Imperial Conference of 1909 had been the determination of the Canadian Government to establish a naval service; and on Jan. 12 1910 a bill for this purpose was introduced into the House of Commons, and became law on May 4 1910. It provided for the creation of a Naval Department, and transferred to it from the department of Marine and Fisheries the wireless telegraph, fisheries' protection, hydrographic and tidal survey branches. It empowered the Government to appoint a Naval Board to advise the minister,

and to organize and maintain permanent, reserve and volunteer forces, and to place at the disposal of His Majesty, for general service in the Royal Navy, ships or men of the Canadian naval service. Provision was also made for a naval college. During the debate on the bill Sir Wilfrid Laurier announced that it was the intention of the Government to construct, in Canada if possible, four cruisers of the improved "Bristol" class, and six destroyers of the improved "River" class. At conferences with the British Admiralty it was agreed that the naval stations for Canada should be two—one on the Atlantic, to include the waters of 30° N. lat. and west of the meridian of 40° W.; and one on the Pacific, to include the waters north of 30° N. lat. and east of the meridian of 180°. Halifax dockyard was taken over from the Imperial authorities on Jan. 1 1906, and the dockyard at Esquimalt on Nov. 9 1910. On Aug. 28 1911 it was announced that the King had approved of the naval forces of Canada receiving the style of "The Royal Canadian Navy," and of the ships-of-war of that navy being designated as "His Majesty's Canadian Ships." On Dec. 16 the following regulations were published with regard to the flag and pennants to be flown by the Royal Canadian Navy: "All ships and vessels of the Royal Canadian Navy shall fly at the stern the white ensign as the symbol of the authority of the Crown, and at the jack-staff the distinctive flag of the Dominion of Canada, such distinctive flag being the blue ensign with the Arms of the Dominion inset in the fly. The white pennant will be flown at the masthead."

In pursuance of Sir Wilfrid Laurier's naval policy, H.M. cruisers "Niobe" and "Rainbow" were purchased and taken over in the autumn of 1910. On July 29 1911, however, H.M.C.S. "Niobe" sustained damage by grounding on the coast off Cape Sable; her repairs were undertaken at Halifax and took 15 months to complete. The building of the proposed new cruisers and destroyers had, however, not been commenced at the time of the resignation of Sir Wilfrid Laurier's Government.

*Mr. Borden's Naval Policy.*—The naval policy of Sir Wilfrid Laurier's Government was that of a Canadian-built and Canadian-controlled navy, but this was criticised by the Opposition as involving a large expenditure, a disunited Imperial navy, and the construction of obsolete types of ships. Upon Mr. Borden's acceptance of office, the naval question became one of renewed interest. Mr. Borden stated that in his view the question of permanent co-operation between the Dominion and the rest of the Empire ought to be fully debated and that the Canadian people should be given an opportunity of pronouncing upon it; pains would be taken to ascertain in the meantime what were the real conditions confronting the Empire. In pursuance of this object, Mr. Borden, with several of his colleagues, visited London in July 1912, and were cordially welcomed by Mr. Asquith's Government, who enabled them, at meetings of the Imperial Defence Committee and otherwise, to obtain all the information available as to the problems of British foreign policy and the naval situation as it presented itself to the British Admiralty. The proposals which the Canadian Government founded on the understanding thus arrived at were left, however, to be made public first in the Dominion Parliament after it met in November.

Mr. Borden's speech on Dec. 5 1912 must always be historic in the relationship between Canada and the mother-country. It was notable for announcing two steps forward in a common Imperial policy. In the first place his "Bill to authorize Measures for increasing the effective Naval Forces of the Empire" proposed to contribute £7,000,000 (\$35,000,000) for the construction and equipment of three first-class battleships, to be under the control of the British Admiralty as part of the Royal Navy, subject to arrangements for their being at the disposal of the Canadian Government if ever a separate Canadian navy were established. And in the second place, by the agreement of the Imperial Government to include a Canadian minister as one of the permanent members of the Committee of Imperial Defence, the principle was recognized that, if the dominions took their share in Imperial defence, they must also have a share in determining Imperial policy. The proposal for an "emergency contribution" of three battleships to the British navy was founded on a similar

randum (published in England on Dec. 5 as a parliamentary paper), drawn up by the Admiralty for the information of the Canadian Government as to the existing international situation from a naval point of view; and Mr. Borden read this out:

As regards the three Canadian battleships now to be added to the navy, Mr. Borden pointed out that, under the Admiralty, the Empire now had what he had convinced himself was the most thorough and effective naval organization in the world, of which it was the best Canadian policy to make use. The hazardous and costly experiment of building up a separate naval organization for Canada was quite unnecessary, and in any case could only provide a poor and weak substitute. In the present emergency the Canadian ships were best employed as part of the Imperial navy under the Admiralty of the mother-country:—

"Those ships will be at the disposal of His Majesty the King for the common defence of the Empire. They will be maintained and controlled as part of the Royal Navy, and we have the assurance that, at any time in the future it will be the will of the Canadian people to establish a Canadian unit of the British Navy, these vessels can be called by the Canadian Government to form part of their Navy; in which case, of course, they will be maintained by Canada and not by Great Britain. In that event, there will, necessarily, be reasonable notice, and indeed, Canada would not desire or suggest the sudden withdrawal of so powerful a contingent from any important theatre in which the naval forces of the Empire might be exposed to severe and sudden attack. In the meantime, I am assured that special arrangements will be made to give Canadians an opportunity of serving as officers in these ships. . . .

"The ships will be built under Admiralty supervision in the United Kingdom for the reason that, at present, there are no adequate facilities for constructing them in Canada. The plant required for the construction of dreadnought battleships is enormous, and it would be impossible at present to have shipbuilding in this country on such a scale. In any case, only half could be built in Canada, because the machinery for armour and guns would, necessarily, be constructed or manufactured in the United Kingdom. The additional cost of construction in Canada would be about \$12,000,000 for three, and it would be impossible to estimate the delay. No one is more eager than myself for the development of the shipbuilding industries in Canada, but we cannot, upon any business or economic considerations, begin with the construction of dreadnoughts, and especially we could not do so when these ships are urgently required within two or three years at the outside for rendering aid upon which may depend the Empire's future existence. According to my conception, the effective development of the shipbuilding industries in Canada must commence with small beginnings and in a businesslike way. I have discussed the subject with the Admiralty, and they thoroughly realize that it is not to the Empire's advantage that all shipbuilding facilities should be concentrated in the United Kingdom. I am assured, therefore, that the Admiralty are prepared in the early future to give orders for the construction in Canada of small cruisers, oil-tank vessels, and auxiliary craft of various kinds. The plant required is relatively small as compared with that which is necessary for dreadnought battleships, and such an undertaking will have a much more secure and permanent basis from the business standpoint. For the purpose of stimulating so important and necessary an industry we have expressed our willingness to bear a portion of the increased cost for a time at least. I see no reason why all the vessels required in future for our Government service should not be built in Canada, even at some additional cost. In connexion with the development of shipbuilding I would not be surprised to see the establishment of a high class of engineering works which will produce articles now imported and not at present manufactured in Canada. Therefore, although the sum which we propose to devote for necessary naval aid at this critical juncture is to be expended in Great Britain, yet we believe that this step will result, under the conditions which I have described, in the very marked development of more than one industry in Canada, and that, even from a purely material standpoint, the step has much to commend it."

The Canadian expenditure now proposed was, in Mr. Borden's view, a moderate one, regarded not as the beginning of a system of periodical contributions, but as an emergency aid at a moment of crisis:—

"If we should neglect the duty which I conceive we owe to ourselves, and if irreparable disaster should ensue, what will be our future destiny? Obviously as an independent nation or as an important part of the great neighbouring republic. What then would be our responsibilities; and what would be the burden upon us for a protection on the high seas much less powerful and less effective than that which we enjoy to-day? Take the case of one nation whose territory, resources, population and wealth may fairly be compared with those in Canada. The naval estimates of Argentina for the four years from 1909 to 1912 inclusive amounted to \$35,000,000 (\$7,000,000). No information is available as to the exact proportion of the

last-mentioned sum which has been appropriated for naval purposes, but it is understood that the far greater portion is for naval construction. It is safe, therefore, to estimate that during the past four years Argentina has expended for naval purposes not less than from \$65,000,000 to \$70,000,000 (£13,000,000 to £14,000,000). The Federal and State expenditure of the United States comprises a total outlay for armaments of between \$250,000,000 and \$300,000,000 (\$50,000,000 and \$60,000,000), or at the rate of \$2.75 per head. Similar expenditure by Canada would mean an annual outlay of some \$20,000,000 to \$25,000,000, or between \$80,000,000 and \$100,000,000 during the same period.

"It is apparent, therefore, that the aid which we propose to bring at this juncture is of a moderate and reasonable character. For 45 years as a Confederation we have enjoyed the protection of the British Navy without the cost of a dollar. . . . So far as official estimates are available, the expenditure of Great Britain on naval and military defence for the provinces which now constitute Canada during the 19th century was not less than \$400,000,000 (\$80,000,000). Even since the inception of our Confederation, and since Canada attained the status of a great Dominion, the amount so expended by Great Britain for the naval and military defence of Canada vastly exceeds the sum which we are now asking Parliament to appropriate. From 1870 to 1890 the proportionate cost of the North Atlantic Squadrons which guarded our coasts was from \$125,000,000 to \$150,000,000 (\$25,000,000 to £50,000,000). From 1853 to 1903 Great Britain's expenditure on military defence in Canada runs closely to \$100,000,000."

As regards the voice which it had been arranged that Canada should have on the Committee of Imperial Defence, Mr. Borden said:—

"With increasing power and influence there has necessarily come, by sure and gradual steps, a certain development in our relations with the United Kingdom and the other dominions. . . . In this constitutional development we are necessarily confronted with the problem of combining coöperation with autonomy. It seems most essential that there should be such coöperation in defence and in trade as will give to the whole Empire an effective organization in these matters of vital concern. On the other hand, each dominion must preserve in all important respects the autonomous Government which it now possesses.

"The responsibility for the Empire's defence upon the high seas, in which it is to be found the only effective guarantee of its existence, and which hitherto has been assumed by the United Kingdom, has necessarily carried with it the responsibility for and the control of foreign policy. . . . When Great Britain no longer assumes sole responsibility for defence upon the high seas she can no longer undertake to assume responsibility for and sole control of foreign policy, which is closely, vitally, and constantly associated with that defence in which the dominions participate. . . . The great dominions, sharing in the defence of the Empire upon the high seas, must necessarily be entitled to share also in the responsibility for and in the control of foreign policy. Not only His Majesty's ministers, but also the leaders of the opposite political party in Great Britain, have explicitly accepted this principle. . . .

"I have alluded to the difficulty of finding an acceptable basis upon which the great dominions coöperating with the mother-country in defence can receive and assert an adequate voice in the control and moulding of foreign policy. We were brought closely in touch with both subjects when we met the British ministers in the Committee of Imperial Defence. That committee is peculiarly constituted, but in my judgment is very effective. It consists of the Prime Minister of Great Britain and such persons as he may summon to attend it. Practically all the members of the Cabinet from time to time attend its deliberations, and usually the more important members of the Cabinet are present. In addition, naval and military experts and the technical officers of the various departments concerned are in attendance. A very large portion of the work of the Committee is carried on by sub-committees, which often are composed in part of persons who are not members of the general committee itself, and who are selected for their special knowledge of the subjects to be considered and reported upon. The amount of work which thus has been performed during the past five or six years in particular is astonishing, and I have no doubt that it has contributed largely to the safety of the whole Empire in time of peril.

"The Committee is not technically or constitutionally responsible to the House of Commons and thus it is not supposed to concern itself with policy. As so many important members of the Cabinet are summoned to attend the Committee, its conclusions are usually accepted by the Cabinet and thus command the support of the majority of the House of Commons. While the Committee does not control policy in any way and could not undertake to do so as it is not responsible to Parliament, it is necessarily and constantly obliged to consider foreign policy and foreign relations for the obvious reason that defence, and especially naval defence, is inseparably connected with such considerations.

"I am assured by His Majesty's Government that, pending a final solution of the question of voice and influence, they would welcome the presence in London of a Canadian minister during the

whole or a portion of each year. Such minister would be regularly summoned to all meetings of the Committee of Imperial Defence and be regarded as one of its permanent members. No important step in foreign policy would be undertaken without consultation with such representative of Canada. This means a very marked advance both from our standpoint and from that of the United Kingdom. It would give us the opportunity of consultation and therefore influence which hitherto we have not possessed."

In opposition to the Government proposals, Sir Wilfrid Laurier on Dec. 12 moved an amendment which, while not negating the first clause of the Government resolution providing for a vote for increasing the effective naval forces of the Empire, would have substituted for the remaining clauses a resolution declaring it necessary that Canada without further delay should enter actively upon a permanent policy of naval defence, and that any measure of aid to Imperial naval defence which did not embody a permanent policy of participation by ships owned, manned and maintained by Canada, was not an adequate expression of the aspirations of the Canadian people. Mr. Borden, said Sir Wilfrid, had asserted that before she enacted a permanent policy Canada must have a voice in all questions affecting war or peace. But that was a large contract, and the question before them was that of emergency and immediate defence. If Canada was represented in the councils of war and peace, the other dominions and dependencies must be also. That question might take years to solve. It must be discussed by itself, and in the meantime Canada should continue in her preparations for defence. Sir Wilfrid Laurier condemned the Government's policy of direct contribution as un-Canadian and un-British, and as unsuited to the real needs. But his influence was no longer in the ascendant.

Owing to the outbreak of the World War in 1914, all these pre-war plans were eventually upset, and the war created an entirely new situation.

*Canada in the World War.*—In the early months of 1914 Canada, for practical purposes, had no army. There was a permanent force of about 3,000 men, with no reserve; its purpose was partly to provide garrisons for a few fortresses, and partly to train the militia. The latter was a lightly trained force, rather well organized for a defensive war on its own soil. The number trained in 1913 was about 60,000. In the late summer and early autumn of 1914 the 1st Canadian Div. of 33,000 men was raised and sent across the Atlantic. It left Gaspé Bay on Oct. 3, and, after nearly three months of additional training in England, landed in France, at St. Nazaire, on Feb. 11 1915. The 2nd Div. was formed immediately and landed in France on Sept. 14, when the Canadian Army Corps was formed. The formation of the 3rd Div. was authorized just before Christmas 1915, and the division was in France early in 1916. The 4th Div. joined the Canadian Corps in the middle of Aug. 1916. The Canadian Cavalry Brigade appeared in France in 1915. After the completion of the Canadian Army Corps the policy of the Dominion was to maintain a comparatively small number of divisions, but always to keep these at full strength, in order that the troops might have the encouragement of full ranks. Until the winter of 1917-8 the Canadian Expeditionary Force was recruited by voluntary enlistment. During the winter the Military Service Act came into operation, and after that time 83,355 recruits were obtained. These were partly men who were drafted and partly men, in the classes called out, who reported voluntarily.

The total number of men enlisted in Canada from the beginning of the war to Nov. 15 1918 was 595,441. The details are:—

Obtained by voluntary enlistment . . . . .	465,984
Drafted or reporting voluntarily after the Military Service Act came into force . . . . .	83,355
Granted leave or discharged . . . . .	24,933
Overseas Service other than C.E.F.:—	
Royal Air Force . . . . .	12,902
Imperial Motor Transport . . . . .	710
Inland Water Transport . . . . .	4,701
Naval Service . . . . .	2,814
Jewish Palestine Draft . . . . .	42
	<hr/>
	21,169
	<hr/>
	595,441

The distribution of these men was as follows:—

C.E.F. proceeded overseas . . . . .	418,052
Enlisted for Royal Air Force, etc. . . . .	21,869
On the strength of C.E.F. in Canada and St. Lucia, including those under training as overseas reinforcements, Siberian Expeditionary Force, Canadian Garrison Regiment, Military Police Corps, Medical and Administrative Services, etc. . . . .	36,533
On harvest leave without pay . . . . .	15,493
Granted leave of absence without pay as compassionate and hardship cases . . . . .	7,216
Number discharged in Canada who had not proceeded overseas for the following among other reasons: as below medical standard, absentees, aliens, to accept commissions, deaths, on transfer to British army and Royal Air Force . . . . .	95,306
Included in enlistment returns for whom discharge documents have not been received, or in some cases duplicate enlistments. This number is being adjusted as further records are received . . . . .	1,760
	<hr/>
	595,441

In addition to the above, 14,590 British and Allied reservists went from Canada to rejoin the colours in their own countries.

The movement overseas by years was as follows:—

Before Dec. 31 1914 . . . . .	30,999
Calendar year 1915 . . . . .	84,334
"    "    1916 . . . . .	165,353
"    "    1917 . . . . .	63,536
Jan. 1 to Nov. 15 1918 . . . . .	73,630

On Sept. 30 1918 about 160,000 men were in France and about 116,000 men in England.

The total Canadian casualties up to and including Feb. 28 1922 were 210,096:—

	Officers	Other ranks	Total
Killed in action and died of wounds . . . . .	2,595	49,079	51,674
Died of other causes . . . . .	297	4,663	4,960
Wounded . . . . .	6,347	143,385	149,732
Prisoners of war . . . . .	236	3,493	3,729
Still missing . . . . .	—	1	1
	<hr/>	<hr/>	<hr/>
Died in Canada . . . . .	9,475	200,621	210,096
Died in Siberia . . . . .	—	18	18
Wounded in Siberia . . . . .	—	1	1
Deaths in Canada on the strength of the Soldiers' Reestablishment . . . . .	—	—	2,809

The honours gained by the Canadian forces included 64 V. C.'s, 710 D.S.O.'s and 2,885 M.C.'s.

The following summary gives only the more notable engagements in which the Canadian troops fought. The Canadian Army Corps in four divisions, forming part of the I. British Army under Sir Julian (later Lord) Byng, was commanded by Lt.-Gen. Sir Arthur Currie. In 1915 the 1st Division greatly distinguished itself in the second battle of Ypres on April 22, and again at Festubert and Givenchy in May and June. In 1916 the Canadians, now forming three divisions, were very heavily engaged at St. Eloi in April, and at Sanctuary Wood and Hooge in June. In Sept., Oct., and Nov. the four Canadian divisions fought in the battle of the Somme, especially distinguishing themselves at Courcellette, Mouquet Farm, and the Kconra, Regina and Désiré trenches. In 1917 the Canadian troops bore the largest part in the taking of Vimy Ridge (April 9) and of Arleux and Fresnoy (April 28 and May 3), and fought with great success in the advance on Lens and the taking of Hill 70 in August. They were again heavily engaged in the fighting round Passchendaele in Oct. and Nov., capturing all their objectives in spite of severe losses. In 1918 the Canadian cavalry, motor machine-guns, and railway troops were active in the resistance to the German advance in March. The Canadian Corps was in the centre of the British front in the second battle of Amiens, Aug. 8-17, advancing 14,000 yd. on the first day, the deepest advance made in one day during the war. In the battle of Arras, at the beginning of Sept., the Canadians played an important part in the breaking of the Quéant-Drocourt line, a part of the Hindenburg system. The Canadian casualties in these two actions were serious, but less than the number of prisoners taken. In the battle of Cambrai, which began on Sept. 27, the Canadians on Oct. 9, after heavy

lines, took Cambrai and made large captures of men and material. In the final stage of the fighting Denain was taken by the Canadians on Oct. 20; Valenciennes on Nov. 2, and Mons at 4 A.M. on Nov. 11, the day on which the Armistice came into force at 11 A.M. The Canadian troops captured 45,000 prisoners, 850 artillery guns, and 4,200 machine-guns, retook 130 towns and villages, liberated 210,000 French and Belgian civilians. Canadian units also served in Palestine, Macedonia and Russia.

The Canadian cavalry fought, for the most part, separately from the Canadian Army Corps. They distinguished themselves in March 1917 by the capture of six villages in two days, and in Dec. gave valuable help in the attack on Villers-Guislains. In the German offensive of March and April 1918 the Canadian Cavalry Brigade was actively engaged and suffered heavy casualties at Bois Meseuil, Rifle Wood and elsewhere. The brigade fought as part of the Canadian Corps in the second battle of Amiens, and, in the great advance at the end of the fighting, captured the town of Le Cateau on Oct. 9. Canadian railway units were attached to all the British armies; these troops were responsible for the whole of the construction of light railways and 60% of the standard-gauge railways in the area occupied by the British forces. In addition to the units of the Canadian Forestry Corps in France, a number of Canadians were engaged in Great Britain in cutting and milling timber.

During the war 1,617 medical officers, 2,002 nursing sisters and 22,382 other ranks of the Canadian Army Medical Corps went overseas from Canada. There were in Canada at the end of the war 913 medical officers, 517 nursing sisters, 282 V.A.D. nurses, and 4,012 other ranks. The Medical Corps had in France 6 general hospitals, 6 stationary hospitals, 6 casualty clearing stations, and 13 field ambulances, and in England 9 active treatment hospitals, 5 special hospitals, 5 convalescent hospitals, and a special sanatorium. In Canada there were 65 military hospitals, with 21,786 beds. Some 22,300 patients were brought back to Canada in 1917 and 1918 on 35 passages of hospital ships. On 27 of these passages the C.A.M.C. provided the staffs of the ships. The "Llandovery Castle" was sunk by a submarine while returning from Canada to England.

About 12,000 troops were required in Canada for home defence—as garrisons for fortresses and guards for internment camps, canals, etc. Canada also furnished a garrison for the important post of St. Lucia in the West Indies. There were 22,902 Canadians in the Royal Air Force, and its predecessors the Royal Naval Air Service and the Royal Flying Corps. In addition, a number of Americans were trained in Canada by the instructional staff of the Royal Air Force. Some 4,701 men were furnished from Canada for the Imperial Service known as the Inland Waterways and Docks. About 710 Canadians joined the Imperial Motor Transport Service, and several hundred Canadians, mostly from the universities, received commissions in the British army. Canada also furnished several hundred doctors and veterinarians and about 200 nurses to the British army. Some 200 Canadian officers were lent, as instructors, to the United States.

As regards the naval service, at the outbreak of the war in 1914 the Canadian Government possessed only two naval vessels—the "Niobe," a cruiser of 21,000-ton displacement, with a main armament of 16 6-in. guns, stationed at Halifax, and the "Rainbow," a small cruiser of 3,600-ton displacement, armed with 8 6-in., 6 4.7-in. and 4 12-pounder guns, stationed at Esquimalt, on the Pacific. The "Rainbow," which was ready for sea, patrolled, with other ships on the Pacific stations, as far south as Panama, and captured several ships carrying contraband of war. After the entry of the United States into the war she became depot-ship on the Pacific coast. The "Niobe" was made ready for sea in Sept. 1914 and remained in commission one year, during which she steamed over 30,000 m. on patrol duty. She afterwards became depot-ship at Halifax.

At the beginning of hostilities various small craft were taken over by the Naval Department from the Departments of Marine and of Customs, and were armed and manned by the R.C.N.V.R. for the performance of patrol duties off the Atlantic coast. Two submarines, which were bought just before the declaration of war,

patrolled the approaches to Victoria and Vancouver and helped in keeping Adml. von Spee's squadron away from the Pacific ports. H.M. sloop "Shearwater" was taken into the Canadian service as mother-ship to these submarines and, in the summer of 1917, these three vessels went, by way of the Panama Canal, to Halifax. A patrol and mine-sweeping service was carried on after the outbreak of war. The vessels used at first were Government and privately owned vessels which were taken over and equipped for the purpose. Some of these were placed at the disposal of the Government free of charge. Early in 1917 the Department of Naval Service undertook to have 60 trawlers and 100 drifters built in Canada for the Imperial Government. These vessels were built at various places on the St. Lawrence and the Great Lakes, many of them were in service in Canadian and European waters in the year 1917 and all were in service in 1918. The area patrolled under the Department stretched from the Straits of Belle Isle to the Bay of Fundy, and from Quebec to east of the Virgin Rocks. Within this area the Department had control of patrols, convoys, mine-sweeping, the protection of fishing fleets, etc. Only one large vessel was lost by enemy attack.

At the date of the Armistice the vessels in the Canadian naval service were as follows. In the Pacific: H.M.C.S. "Rainbow," depot and training ship; H.M.S. "Algerine," sloop; auxiliary patrol ship "Malaspina"; several motor-launches for harbour defence. In the Atlantic: H.M.C.S. "Niobe," depot and training ship; H.M.C.S. "Shearwater," submarine depot ship, and 2 submarines; H.M.C.S. "Onisk," torpedo-boat destroyer; 9 auxiliary patrol ships, 47 armed trawlers, 58 armed drifters, 11 armed mine-sweepers and tugs, and a large flotilla of motor-launches. The crews of these vessels consisted of men from all parts of Canada, principally members of the Royal Canadian Naval Volunteer Reserve. At the date of the Armistice the personnel of the service was: officers and men of the Royal Canadian Navy, 7,499; officers and men of the Royal Canadian Naval Volunteer Service, 4,374.

In addition to the men serving in Canadian vessels, over 1,700 men were recruited in Canada for the Imperial navy, 73 surgeon probationers and a number of hydrographic survey officers were sent from Canada and 580 Canadians enrolled as probationary flight lieutenants in the Royal Naval Air Service, before recruiting for the Royal Air Force began in Canada. More than 500 Canadians holding commissions in the Royal Naval Volunteer Reserve were in the British Auxiliary Patrol and similar services.

The Royal Canadian Naval Air Service was established in the summer of 1918, with stations at Halifax and North Sydney. It cooperated with the U.S. Naval Aviation Corps in patrolling the coast and escorting convoys through the danger zone.

The Canadian Radiotelegraph Service controlled about 200 stations ashore and afloat. Several new stations were erected or taken over by the Department of Naval Service, and there was an unbroken chain of radio communication from St. John's, Newfoundland, to Demerara. The Department opened a training school for wireless operators, from which about 200 men were sent out for service in all parts of the world.

Important refitting, repairing and supply work was done by the Canadian dockyards. Large refits of Imperial and other ships were made at Esquimalt, including H.M.S. "Kent" after the battle of the Falkland Is., and the Japanese battleship "Asama," after grounding on the coast of Lower California. Several large cruisers were refitted at Halifax and Montreal. Other work included the defensive armament of merchant ships, the refitting of transports for troops, horses and special cargo, and the loading and securing on ships' decks of 600 large launches, tugs, etc.

The Canadian Naval Service provided supplies for the ships of the Royal Canadian Navy and for a number of Imperial and Allied ships in Canadian waters, as well as many of the requirements of H.M. dockyards at Bermuda and Hong-Kong. Large supplies were shipped from Halifax dockyard for provisioning the fleets in European waters. A large coaling depot was established at Sydney for the use of patrolling vessels and of all convoys leaving the St. Lawrence.

In shipbuilding Canada had a splendid war record. Nearly 1,000 vessels of one kind or another were turned out for the war.

ous Allied Governments, these including steel and wooden freighters, submarines, coastal patrol boats, lighters, drifters, etc. During the war period not only was wooden shipbuilding revived but the steel shipbuilding industry was placed firmly on its feet; for whereas in 1914 Canada had only two thoroughly up-to-date steel shipbuilding plants, in 1918 she had seventeen. In 1919 25,000 men were employed in the industry. The Department of Naval Service secured many of the first of these orders.

The Imperial Munitions Board, acting as the agent for the Imperial and Allied Governments, placed contracts with Canadian yards for \$70,000,000 worth of shipping. In 1918 the Dominion Government, through the Department of Marine and Fisheries, launched its shipbuilding programme, which in its entirety called for 63 steel vessels having a deadweight tonnage of 375,000, constituting its own mercantile marine. The approximate value of these orders was \$75,000,000. The first contract was signed on March 4 1918. All these vessels were built in Canadian yards and of Canadian material.

Canada became thoroughly and quickly organized for carrying on the war in all its phases. There were a number of committees, commissions, boards, etc., formed for various purposes, the members of which worked voluntarily. These were the Shell Committee, the Imperial Munitions Board (which had a wide scope of usefulness and responsibility), War Trade Board, Board of Grain Supervisors, War Mission to Washington, the Food Board (under the direction of a food controller), Fuel Control (under the direction of a fuel controller), and the Canadian Railway War Board.

Canadians gave liberally to all the organizations engaged in relief and help of any kind. The following is a summary of gifts for various war purposes from the Dominion and Provincial Governments, from municipalities, societies, universities, business houses and other corporations, and from private individuals:—

Canadian Patriotic Fund (to Feb. 28 1921)	\$18,704,663
Manitoba Patriotic Fund (to March 31 1918)	3,957,042
Canadian Red Cross Society (to Dec. 31 1920):—	
Contributions in cash	9,074,208
Gifts in supplies (estimated)	15,000,000
British Red Cross Society (to Dec. 31 1919)	6,250,000
Belgian Relief Fund (to Dec. 19 1918):—	
Contributions in cash	1,642,104
Gifts in supplies (estimated)	1,512,800
Contributions from Canada to Y.M.C.A. for military work	4,574,821
Gifts from Dominion and Provincial Governments to Government of United Kingdom	5,469,316
Miscellaneous gifts	8,000,000
Total	\$104,184,954

Of the various war organizations working in Canada, or among Canadian troops overseas, the most extensive in their operations were the Canadian Patriotic Fund, the Canadian Red Cross Society, and the military branch of the Y.M.C.A. The Canadian St. John Ambulance Association and Brigade, which were branches of the Order of St. John of Jerusalem in England, coordinated their war work with the Canadian Red Cross Society. The Association during the five years of the war instructed 61,612 Canadians in first aid and home nursing, for volunteer work either in Canada or overseas. In addition courses in first aid were given to 200,000 troops while in training in Canada.

Statistics, however complete, can give only an imperfect impression of the services which Canadian women rendered during the war. Women to the number of 2,400 went overseas in the C.E.F. and served in England, France, Belgium, Egypt, Greece and Russia. They were posted for duty in base hospitals, clearing stations, ambulance trains and hospital ships. There were also 527 on duty in Canada.

The casualties suffered by nurses were:—

Killed in action	2
Died at sea	13
Died of wounds	5
Died of disease (out of Canada)	17
Died in Canada	17

The number of V.A.D.s who went overseas was 342; these served in hospitals in England and France. Many hundreds of Canadian women served in Canada as volunteer hospital

probationers in military hospitals and in England, under the Joint War Committee's Women's V.A.D. Department.

**Returned Soldiers.**—Some time before the close of the war provision was made by the Government by repeated Acts for the care of the returned soldiers. The Military Hospitals Commission was appointed in June 1915. It provided 16 hospital cars and had hospital accommodation at the commencement of 1917 for 1,500 patients. It provided during 1917 20,000 beds in 43 centres. Vocational training for disabled men was organized in 1916. The number who commenced courses was 90,521, those who completed 36,826, and those who discontinued 8,981. In Feb. 1918 a Department of Soldiers' Civil Reestablishment was organized to take over the work of the Hospitals Commission. An arrangement was made for the treatment of all invalided soldiers returned except those suffering from tuberculosis, epilepsy, paralysis, insanity and mental deficiency, which came directly under the D.S.C.R. The total of clinical treatments was 586,285. The information and service branch in connexion with the Department placed in employment 207,000 men. The number of situations found was 174,784. The pension branch rendered a most important service in connexion with permanently maimed soldiers, widows, mothers and children of soldiers who were killed. The total number to whom pensions were awarded was 110,702, and the aggregate of pensions paid to Dec. 1920 amounted to \$81,659,636. The number of pensions in force at the end of 1920 was 73,670, and the amount in force on that date was \$31,169,520. At various times from 1914 to 1920 the rate of pensions was substantially increased. For instance in 1914 the rate per annum for disability was \$264, and in 1920 it was \$600, with \$300 for the wife, \$180 for one child and a lesser amount for subsequent children. The annual rate for dependents of deceased soldiers increased practically in the same proportion. In addition to pensions, war service gratuities were paid to the amount of \$164,000,000. Added to the pension system was a provision made for Government insurance of returned soldiers, including naval and air forces. The amount of insurance in force in 1921 was \$5,225,000. Applications received amounted to 1,705.

The Soldier Settlement Act made provision for the settlement of returned soldiers on the land. It empowered a board consisting of three members to make a soldier grant of 160 ac. of Dominion land in the Western Provinces, and returned men were also eligible for a civilian homestead of another 160 acres. The Act also empowered the board to make loans to enable returned men to settle in any province. Loans might be granted up to \$7,500 to qualified settlers purchasing land through the board, the settler to pay down 10% of the cash value of the land; up to \$3,000 for equipment and improvements, and up to \$5,000 to settlers who already owned land to enable them to pay off old mortgages and to purchase live stock and implements and to erect buildings. Up to March 31 1921 the board received 59,321 applications; 43,663 were granted certificates; 25,443 had gone on the land; 29,771 of whom received financial assistance amounting to \$80,371,750.48. The total area of land occupied by soldier settlers under the Act was 4,854,790 ac.—purchased land 2,153,184 ac., encumbered land 260,227 ac., soldier grants (with loans) 980,208 ac., soldier grants (without loans) 1,361,280 acres. The value of the main crops produced by soldier settlers in 1920 was \$13,953,178.

The following figures show the number of loans approved and the amounts by provinces:—

Province	Number of Loans Approved	Total Amount of Loans Approved
Prince Edward Island	304	\$ 819,507
Nova Scotia	399	1,310,069
New Brunswick	522	1,487,680
Quebec	456	1,993,340
Ontario	1,423	6,163,808
Manitoba	3,311	13,420,640
Saskatchewan	4,963	20,319,360
Alberta	5,790	23,233,342
British Columbia	2,954	12,697,222
	29,122	\$81,354,948

These loans were for the following purposes:—

To purchase land	\$44,463,951
To remove encumbrances	2,213,897
For permanent improvements	9,408,394
For stock and equipment	25,268,706
	\$81,354,948

The Dominion Government also appropriated the sum of \$25,000,000 for housing in Canada. The object of the Government was to provide houses for working-men, particularly returned soldiers, at the actual cost of building and land acquired at a fair value, thus eliminating the profits of the speculator.

*After the War.*—One result of the war was that Canada, along with other dominions, acquired a substantially new status in the Empire. Sir Robert Borden, as Canadian Prime Minister, was a member of the Imperial War Cabinet. Members of the Canadian Government attended the Peace Conferences, signed the Peace Treaties, and were members and participated in the deliberations of the League of Nations. Finally it was decided that Canada should be represented at Washington by a Canadian ambassador, distinct from, and with responsibilities quite apart from those of, the British ambassador.

During the war a general election had taken place on Dec. 17 1917, the Unionist Government under Sir R. Borden being opposed by the Laurier Liberals, the result being the return of 150 Unionists and 80 Opposition members. After the signing of the Armistice a certain number of the Liberals elected as Unionists to support the Government returned to the Liberal side of the House in Opposition. As the result of by-elections, representatives of the Farmers' party were also elected and sat upon the cross-benches, which included several former Liberals from the Middle West. At the close of the 1920 session of Parliament the Unionist party by that name ceased to exist, and there was formed the National Liberal and Conservative party, with a policy strongly protective in principle. In Aug. 1919, as the result of the death of Sir W. Laurier (Feb. 17 1919), a huge convention of Liberals was held at Ottawa to select a leader in succession to him, and to frame a platform. After an exciting contest of several days the Hon. William Lyon Mackenzie King was elected, and a fiscal policy was approved in favour of free imports of all foodstuffs and implements of production.

On March 21 1921, Sir Robert Borden having resigned the premiership, Mr. Arthur Meighen (b. 1874), as his successor in the Conservative leadership, was called upon to form a government. It included Sir George E. Foster as Minister for Trade and Commerce. Mr. Meighen subsequently attended the Imperial Conference in London in July 1921. But he and his party, standing on a high tariff platform, were heavily defeated at the general elections on Dec. 6. For the first time in Canada, women exercised the vote. The Liberal party, under Mr. King, were returned 121 strong, the Conservatives numbering only 57, the Progressives (under Mr. T. A. Crerar) 60, and Independents 2. The result was a victory for the Liberal policy of a tariff for revenue only, with British preference, but with reciprocity as regards the United States. Mr. Mackenzie King (b. 1874), who had been Minister for Labour for eight years under Laurier, thus found himself at the head of a clear majority over all other parties.

*Lord Jellicoe and the Canadian Navy.*—In pursuance of Instructions from the Lords of the Admiralty to advise the Dominion in respect of a scheme of naval defence, Lord Jellicoe visited Canada in 1919 and his report was issued early in 1920. On June 14 1920 the Hon. C. C. Ballantyne made an official statement of policy in the Canadian House of Commons. He stated that the Government had not yet decided on a permanent programme, and would not so decide until after the matter had been discussed by an Imperial Conference and a decision had been arrived at by Great Britain on an Imperial naval policy. In the meantime the Canadian navy would be maintained on pre-war lines. The offer by the Imperial Government of one light cruiser and two torpedo-boat destroyers to take the place of the obsolete training ships, the "Niobe" and the "Rainbow," had been accepted. To make way for reorganization, it had been decided to demobilize all officers and naval ratings, discontinue certain civilian help at

Headquarters and at the naval dockyards at Esquimaux and Halifax, to recall all officers with the Imperial fleet and place them in the Canadian service, and to continue the Naval College.

*Prince of Wales' Visit, 1910.*—The year 1910 was made notable by the visit of the Prince of Wales. King Edward VII., as Prince of Wales, had visited Canada in 1860, and King George V., in the same capacity, in 1901. This tour of the Prince of Wales in 1910, however, was the most extensive ever made by any member of the royal family. He arrived in St. John's, Newfoundland, on Aug. 12, and from Aug. 15 to his departure for England from Halifax on Nov. 25 he visited every part of Canada accessible by railway communication from the Atlantic to the Pacific, being welcomed with the greatest enthusiasm everywhere; and in the course of his visit the Prince laid the corner-stone of the tower of the new Parliament Buildings at Ottawa.

*Prohibition.*—After the commencement of the World War all the Canadian provinces took steps toward the prohibition of intoxicants or the severe restriction of their use, as a war measure, to be effective during the period of the war. In British Columbia this was brought about by the submission of a referendum in the form of a statute. In other provinces prohibition measures were the results of direct action by the Legislatures. New Brunswick, Nova Scotia and Prince Edward I. had been largely "dry" before the war under the local option provisions of the Canada Temperance Act, but these, too, tightened up the existing law by provincial measures. In nearly every instance the purchase of liquors, with the exception of very light beer, where the sale of this was permitted, was possible only through medical prescription, and liquors were only available at drug-stores or Government shops. In Quebec a bill introduced in 1918 provided for total prohibition on May 1 1919. A subsequent bill of 1919 retained all the clauses of the Act of 1918, except in respect of the sale and use of beer and light wines, which were subject to a referendum, the result of which was: in favour, 178,112; against, 48,433. In the four western provinces much complaint was made by prohibitionists of the laxity of enforcement, which was admitted in official quarters to be a matter of great difficulty, and a discussion arose in all the provinces as to the advisability of restrictive measures of the nature then in force. On the prohibitionist side it was urged that more stringent laws should be enacted and better machinery provided for enforcement. On the other, the "moderation" side, Government control was advocated. An appeal was made to the Dominion authorities to prevent manufacture and the export and import as among provinces. Two provinces, British Columbia and Quebec, declared for Government control, and in both that system became effective. The Government of Canada endeavoured through the House of Commons to restrict the manufacture, transportation and importation of liquors during the war and for 12 months thereafter, but the measure was defeated in the Senate and abandoned. A subsequent law was enacted leaving the matter in the hands of the various provinces, as the result of referenda.

By statute assented to on Nov. 10 1919 provision was made for taking, at the request of any provincial legislature by resolution, a vote in the province upon the question whether the importation of intoxicating liquor therein should be prohibited, and the machinery for such votes, previously defective, was improved in 1920 by another statute, assented to on July 1 1920. Proclamations were at once issued directing votes to be taken on Oct. 25 following in the provinces of Nova Scotia, Manitoba, Alberta, Saskatchewan, and Ontario. These votes resulted as follows:—

	For	Against
Nova Scotia	83,422	23,874
Manitoba	68,831	55,056
Alberta	68,012	44,321
Saskatchewan	86,949	55,289
Ontario	540,773	373,938

The Yukon territory in June 1921 carried a referendum in favour of sale of intoxicants under Government control. It had previously been "dry."

*Viceroy.*—As governor-general of Canada Earl Grey had been succeeded in 1911 by the Duke of Connaught, who in turn was



succeeded by the Duke of Devonshire in 1916; and when the Duke of Devonshire's term expired on July 18 1921, he was succeeded by Gen. Lord Byng of Vimy. (W. L. G.\*)

#### CANADIAN LITERATURE

*English-Canadian.*—The literary record of Canada in 1910-21 falls more or less definitely into three sections—pre-war, war and post-war. During the war years the heart of the Canadian people became so completely absorbed in the great conflict, in which they had so much at stake, that, after the first year or so at any rate, there remained little room for any intellectual activity not connected directly or indirectly with the war and its successful prosecution. The new literature of 1910-14 had reflected the characteristic of the Dominion in those years—a spirit of optimism, of national self-consciousness, of conservatism in the broader sense, and intellectually of wider and more stimulating horizons. And the return to peace conditions, during 1918-21, was mainly notable in literature for more or less thoughtful reviews of Canada's part in the war, consideration of her problems of reconstruction, and the picking up anew of the somewhat neglected threads of her intellectual life.

Unquestionably the most important achievement of the pre-war period was the publication of *Canada and its Provinces*, a comprehensive survey of the history of the country in 23 volumes, edited by Dr. A. G. Doughty and Dr. Adam Shortt, and counting among its contributors most of the recognized authorities in Canadian history, biography and economics. Another notable essay in Canadian history was the series known as the *Chronicles of Canada*, in 32 volumes, edited by George M. Wrong and H. H. Langton, a series designed to present in attractive and at the same time authoritative form the outstanding events of Canadian history. The authors of the individual volumes included such well-known writers as Charles W. Colby, of McGill University, Col. William Wood, Stephen Leacock, Dr. Doughty, Oscar D. Skelton, of Queen's University, and Sir Joseph Pope. The publication in 1911 of an *Index and Dictionary of Canadian History* completed the series of biographies known as *The Makers of Canada*.

The celebration of the tercentenary of the founding of Quebec brought in its train, with a flood of purely ephemeral literature, several books of permanent value, such as *The King's Book of Quebec* (1911), edited by Dr. Doughty and Col. Wood, James Douglas' *New England and New France* (1913), Wood's *In the Heart of Old Canada* (1913), and Prof. Wrong's *The Fall of Canada* (1914). In 1920 the Hudson's Bay Company celebrated its 250th birthday with elaborate pageants in Winnipeg and elsewhere throughout the West. The occasion was also marked by the publication of a very completely illustrated history of the Company. In 1921 McGill University celebrated the 100th anniversary of its charter.

This period also witnessed a succession of biographies and autobiographies of famous Canadians, including Beckles Willson's *Lord Strathcona* (1914) and W. T. R. Preston's pungent life of the same many-sided character, Sir Richard Cartwright's *Reminiscences* (1912), Sir George W. Ross' *Getting into Parliament and After* (1913), L. J. Burpee's *Sir Sandford Fleming* (1915), John Boyd's *Sir George Etienne Cartier* (1914), Sir Charles Tupper's *Recollections of Sixty Years in Canada* (1914), and Goldwin Smith's posthumous *Reminiscences* (1910), *Life and Opinions* (1913) and *Correspondence* (1913), all three edited by his literary executor, Arnold Haultain.

Other noteworthy books of this period are W. H. Atherton's *Montreal 1535-1914* (1914), John Ross Robertson's *Landmarks of Toronto* (1914), E. H. Oliver's *The Canadian North-West* (1914), and Doughty and McArthur's *Documents relating to the Constitutional History of Canada, 1791-1818* (1914); and in books of description and travel, A. P. Coleman's *The Canadian Rockies* (1911), Ernest Thompson Seton's *Arctic Prairies* (1911), Dr. Campbell's *Canadian Lake Region* (1910), and Charles Sheldon's *Wilderness of the Upper Yukon* (1911). Among a host of political and economic essays may be mentioned John S. Ewart's *The Kingdom Papers* (1914), Sir William Peterson's *Canadian*

*Essays and Addresses* (1912), Sir George Foster's *Canadian Addresses* (1914), Sir Andrew Macphail's *Essays in Politics* (1910), Maj.-Gen. C. W. Robinson's *Canada and Canadian Defence* (1910), and Edward Porritt's *Review in Canada against the New Feudalism* (1911). In 1913 a new edition also appeared of Col. George T. Denison's *History of Cavalry*, written as early as 1876, and awarded in the following year the prize offered by the Tsar of Russia for the best essay on the subject.

In imaginative literature, the only books of verse that need be noted here are Bliss Carman's *Echoes from Vagabondia* (1912), William Wilfrid Campbell's *Sagas of Yaster Britain* (1914), William Henry Drummond's *Poetical Works* (1912), Marjorie Pickthall's *Drift of Pinions* (1913), Frederick George Scott's *Poems* (1912), and Arthur J. Stringer's *Open Water* (1914). In 1913 Dr. Campbell brought out his excellent anthology, the *Oxford Book of Canadian Verse*. In fiction, the most noteworthy names are those of Miss L. M. Montgomery, Charles G. D. Roberts, Norman Duncan, C. W. Gordon ("Ralph Connor"), Theodore Roberts, Alan Sullivan and Arthur Stringer.

With regard to the literature of the war, or of Canada's part in it, many volumes of personal experiences had already been published by 1921. A really notable book is *Winged Warfare* (1918) by Col. William A. Bishop, V.C. Others that may be named here are Col. George G. Naismith's *On the Fringe of the Great Fight* (1917), F. C. Curry's *From the St. Lawrence to the Yser* (1917), F. McKelvey Bell's *First Canadians in France* (1917), and *Captured* by Lieut. J. Harvey Douglas (1918). In 1917 appeared the first of six volumes of *Canada in the Great World War* (completed in 1921), an authoritative account of Canada's part in the conflict, by a number of competent writers. An official history of the war, from a Canadian viewpoint, under the title of *Canada in Flanders*, the first two volumes of which were prepared by Lord Beaverbrook and the third by Maj. Charles G. D. Roberts, appeared in 1916-8. Other war books of interest are Col. J. G. Adami's *Official War Story of the C.A.M.C.* (1919), Dr. Herbert A. Bruce's *Politics and the C.A.M.C.* (1919), J. F. B. Livesay's *Canada's Hundred Days* (1910), Hon. Henri S. Beland's *Three Years in a German Prison* (1919), Alan Sullivan's *Aviation in Canada* (1919), Capt. Harwood Steele's *Canadians in France* (1920), John W. Dafeo's *Over the Canadian Battlefields* (1919), and Sir Robert Borden's *The War and the Future* (1917). Through the foresight of Lord Beaverbrook and Dr. Doughty, Canada acquired an exceptionally complete collection of war records, paintings, and trophies.

Among the more significant of the post-war books are Sir Robert Falconer's *Idealism in National Character* (1920), J. L. Morison's *British Supremacy and Canadian Self-Government* (1919), Hon. W. L. Mackenzie King's *Industry and Humanity* (1918), R. M. MacIver's *Labour in the Changing World* (1919), W. C. Good's *Production and Taxation in Canada* (1919), A. H. Reginald Buller's *Essays on Wheat* (1919), Prof. Wrong's *The United States and Canada* (1921), W. G. Smith's *Study in Canadian Immigration* (1920), and two books discussing the relations between English-speaking and French-speaking Canada—O. W. H. Moore's *The Clash* (1918) and P. F. Morley's *Bridging the Chasm* (1919).

In history and biography there were such important works as J. S. McLennan's *Louisbourg* (1918), Chester Martin's *Lord Selkirk's Work in Canada* (1916), G. C. Davidson's *North West Company* (1919), William Smith's *History of the Post Office 1639-1870* (1920), W. R. Riddell's *Old Province Tales* (1920), Prof. Skelton's *The Canadian Dominion* (1919), Sir John Willison's *Reminiscences* (1919), W. T. Grenfell's *A Labrador Doctor* (1919), E. M. Saunderson's *Life of Sir Charles Tupper* (1916), Skelton's *Sir Alexander Galt* (1920), and Sir Wilfrid Laurier (1921), Sir Joseph Pope's *Correspondence of Sir John Macdonald* (1921) and Walter Vaughan's *Sir William Van Horne* (1920). The Historical Section of the Canadian General Staff issued the first three volumes of an official *History of the Military and Naval Forces of Canada from 1763 (1920-21)*.

Of agencies which each in its own way, were making in these later years for the development of intellectual life and scholar-

ship in Canada, none was more important than the Dominion Archives, the Royal Society of Canada, the Champlain Society, and two important Canadian periodicals, the *University Magazine* and the *Canadian Historical Review*. The Archives perform a triple service, in collecting and safeguarding the manuscript treasures of Canada, in affording facilities for research to students, and in publishing selected documents from its collections. The Champlain Society, with headquarters in Toronto, devotes itself to the publication of important works bearing upon Canadian history, and the reprinting of old works in the same field. J. B. Tyrell's editions of Hearne's *Journey* (1912) and David Thompson's *Journals* (1916), Dr. Doughty's edition of Knox's *Historical Journal* (1914-16), Grant and Bigger's edition of Lescarbot's *New France* (1921) and Col. Wood's *Select British Documents of the Canadian War of 1812* (1920), are admirable examples of Canadian scholarship. The establishment of the *University Magazine* under the control of three of the principal Canadian universities, and the transformation of the annual *Review of Historical Publications Relating to Canada* into a quarterly *Canadian Historical Review* widened the opportunities for the intellectual discussion of Canadian questions by Canadian writers in a Canadian periodical.

In imaginative literature during this later period, there are found several arresting books, such as Clive Philippe-Wolley's *Songs from a Young Man's Laid* (1917), John McCrae's *In Flanders Fields* (1918), Lloyd Roberts' *Poems* (1919), Norah Holland's *Spun Yarn and Spindrift* (1918), Marjorie Pickthall's *The Lamp of Poor Souls* (1916), Bliss Carman's *April Airs* (1916), Duncan Campbell Scott's *Lundy's Lane and Other Poems* (1916) and *Beauty of Life* (1921), Arthur S. Bourinot's *Poems* (1921), and Bernard F. Trotter's *Canadian Twilight* (1917). In fiction, the principal names were Sir Gilbert Parker, C. G. D. Roberts, Arthur Stringer, Theodore Roberts, W. A. Fraser, L. M. Montgomery, C. W. Gordan, Basil King and Norman Duncan. Among Canadian humorists Stephen Leacock (b. 1869 in England; on the staff of Upper Canada College, 1891-9; and later head of the department of political economy at McGill University) during 1912-21 had gradually established a widespread popularity, and his volumes of humorous essays and sketches gave him an international reputation as a writer, somewhat eclipsing his professional position as an economist. In this connexion also may be mentioned the *Goblin*, a really excellent comic monthly published by undergraduates of Toronto University. Two delightful books for children are Isabel Ecclestone MacKay's *The Shining Ship* (1918) and Cyrus MacMillan's *Canadian Wonder Tales* (1918). R. P. Baker has written a *History of English Canadian Literature to Confederation* (1920). (L. J. B.)

*French-Canadian.*—During 1910-21 there was a very natural desire among French-Canadian writers to do all that could be done toward keeping their compatriots true to type in race, religion, speech, thought, aspiration, letters and whatever else might encourage a distinctive form of life to persist unchanged by contact with the English-speaking world. Among the extreme Nationalists this unfortunately led to a self-conscious particularism, tending rather to weaken both ideas and expression by confining them within a narrow pale than to win an assured position in the intellectual world at large. The best written, however, of all the French-Canadian papers was *Le Devoir*, edited by Henri Bourassa, the Nationalist chief, who had kept it easily first in literary excellence, with the able assistance of Omer Héroux, Georges Pelletier, Ernest Bilodeau, Madame E. P. Benoit ("Monique"), and Madame H. St. Jacques ("Fadette"). Another Ultra, the Abbé Lionel Groulx, edited *L'Action Française*, a monthly numbering among its contributors that excellent stylist, Père Beaudé, whose *nom de plume* is Henri d'Arles. A wider outlook was taken by *La Canada Française*, successor to *La Nouvelle-France*, once led by the scholarly pen of the Rev. Camille Roy. The widest and most diverse views were to be found in *La Revue Moderne*, edited by Madame Huguenin. *La Revue Trimestrielle* also took broad views, and had done good service to literature.

Three types of French-Canadian history were represented by (1) the *Histoire du Canada*, a big school-book written by the Christian Brothers from their own point of view, and without any reference to archives; (2) the five volumes of the *Cours d'Histoire*, ardently written by the Abbé Groulx in admirable French, and based on original sources, but carefully dividing the sheep of his own party from the goats of all others; and (3) the *Cours d'Histoire du Canada* by Thomas Chapais, whose scholarly taste, deep reverence for original research, and wide experience of public life preëminently fitted him for his distinguished rôle as professor of the Université Laval. Montreal was highly favoured in possessing that indefatigable archivist, E. Z. Massicotte. But Quebec was the headquarters of the new Provincial Archives, established in 1920 under the direction of Pierre Georges Roy, whose name had become famous for all that concerns the discovery, study, classification, and enlightened cataloguing of original documents, as well as for archival work at large.

Folklore was more and more studied by C. Marius Barbeau (Dominion Anthropologist), E. Z. Massicotte, C. Tremblay, Dr. Cloutier, Gustave Lanctôt, and others. The *Journal of American Folklore* devotes one number a year to the work of French-Canadians.

Pure literature made a very real advance in the decade. The great French-Canadian drama was still to seek; but in poetry Jean Nolin's *Les Cailloux* showed good achievement and still greater promise, while power was the predominant note of Charles Gill's *Le Cap Éternité*. Two women who emerged as poets had already done well and seemed likely to do better: Marie Le Franc's *Les Voix au Cœur de l'Âme* is both psychology and art; while Blanche Lamontagne's *Visions Gaspésiennes*, *Par Nos Champs et Nos Rives*, and *La Vieille Maison* showed a continual advance from merely tuncful and rather diffuse description to something like creation. Jules Fournier and Olivier Asselin, both most competent critics, had edited the *Anthologie des Poètes Canadiens* (1920). Fiction was well represented by Damase Potvin's *L'Appel de la Terre*. The late Louis Hémon, a Frenchman who lived and worked with the French-Canadian habitants, had, in his *Maria Chapdelaine* (1916), written a novel which was a true work of art and racy of the soil.

In other literature Laure Conan produced the best of introspective sketches in *L'Obscure Souffrance*, which is a kind of *journal imaginaire*. Her terse and finely chosen style greatly helped her penetrating vision to reach the very heart of her subject in everything she wrote, as, for instance, in her *Silhouettes Canadiennes*. Edouard Montpetit was both reminiscent and "previsionist" in his *Au Service de la Tradition Française*. And Adjutor Rivard, whose *Chez nos Gens* gives moving glimpses of *habitant* life, has placed all students of French under a deep debt of gratitude in his magnificent *Études sur les Parlers de France au Canada*. (W. Wo.)

CANALEJAS Y MÉNDEZ, JOSÉ (1854-1912), Spanish politician, was born in Ferrol July 31 1854. Coming of a middle-class family with university connexions, he graduated (1871) at the university of Madrid and took his doctor's degree (1872), becoming lecturer on Literature (1873). For a time he entered his father's engineering works as general secretary and studied railway problems, but continued his literary work, publishing a history of Latin literature in two volumes. He was early attracted to politics, sympathizing first with the Republican and then with the Liberal party. He was elected deputy for Soria in 1881 and his parliamentary ability asserted itself from the first. He became under-secretary for the prime minister's department under Posada Herrera in 1883, then Minister of Justice (1888) and of Finance (1894-5). He was president of the Chamber in the Moret administration, and became prime minister and chief of the Liberal party in 1910. It was while in office that he was murdered in Madrid Nov. 12 1912. Canalejas was a remarkably consistent statesman. He believed in the possibility of a monarchy open to a thoroughgoing democratic policy both in economic and in strictly civil and political matters. A sincere Catholic, he was nevertheless a strong anti-clerical, and a champion of

the rights of the State against the encroachments of the Church. By his death the Spanish Liberal party lost the only statesman capable of uniting it under one definite programme.

**CANCER** (see 5.175).—No striking change was witnessed in the years from 1910 to 1921 in the general attitude of medical men to the problem of cancer. Some new considerations have been submitted, however, and some new aspects of the subject disclosed. Industrial cancers occurring in tar workers and workers in paraffin shale have been the subject of observation by the Home Office in England, while the association between certain of the aniline products and malignant disease of the bladder has been pointed out in connexion with the health of German dye workers. Sir George Lenthal Cheatle has published, too, some observations on the manner of invasion of breast cancers which tend to show a passage up the milk ducts.

Generally speaking, the view is still held that while cancer tends to make its appearance on areas which have been subjected to irritation of one kind or another, there remains an unknown factor which determines its actual onset. Only a small percentage of cases which are subject to chronic irritation ever become malignant. This fact alone rules out the explanation of new growth in terms of local or even general irritation—a consideration which applies even to cancers in radiological practice.

In these circumstances a special interest attaches to the recent experiments initiated by Prof. Fibiger of Copenhagen. In 1913 this worker obtained for experimental purposes a number of rats. On examination he found that several of these had carcinomata of the stomach and further purchases from the same dealer produced more cancers. After most painstaking investigations Fibiger found that all these rats came from a certain sugar refinery which was infested with cockroaches. He obtained some of the cockroaches and had them examined. It was then found that they were carriers of an unknown nematode worm. This worm was consequently named *Spiroptera neoplastica*. The female is 4 to 5 cm. long by about 0.2 mm. in diameter; the male less than half this size. The eggs are oval and clear and measure about 0.06 mm. and contain curled-up embryos. They can be seen in the body of the female or in the upper layers of the gastric epithelium, but occur only in that part of the stomach which is lined by squamous epithelium.

By feeding rats on the cockroaches or by giving them ova of the nematode to eat Fibiger was able to produce warty growths in their stomachs and occasionally cancers. He published a further paper in 1920 in which it was pointed out that the embryos of the worm having been hatched in the cockroach pass to the muscles of that insect and there encyst themselves. When the rat eats the cockroach the embryos are set free. Fibiger took rats and fed them on various forms of this worm and then examined 116 of them which had survived for periods of 30 to 298 days. The stomach of each was examined in serial section. None of the rats which died within 44 days of the eating of the worm showed any signs of cancer, but of 102 rats which survived from 44 days up to 298 days no fewer than 54 showed quite typical carcinoma of the squamous-cell type in the gastric cul-de-sac. In the remaining 48 only benign proliferations and inflammations were found. These are almost invariably produced by the spiroptera.

Of the rats which died with gastric cancer in from one and a half to three months after injection of the infected material 20 had very small tumours, but 5 had multiple carcinomata; of 26 which lived for from three to ten months 18 had tumours of fairly large size and 8 had minute nodules while 15 had multiple cancers. Finally 8 rats which lived for prolonged periods had large tumours. The tumours, too, set up metastases which as a rule tended to be localized in the animals' lungs.

Cancer of the stomach had up till 1920 been produced in 89 rats. There had also been produced in some rats cancer of the tongue. In this latter case 217 rats were experimented on, care being taken to obtain mixed breeds. A relatively small number of rats developed inflammation of the tongue and a still smaller number got cancer. The inflammation began a few days after the injection of the spiroptera and in the great majority of cases was spontaneously cured in from two and a half to six months; it attacked all parts of the tongue; there was thickening of the epithelium of the organ. The cancer produced was found to be exactly similar to the cancer of the tongue found in human beings. The cancer persisted after the inflammation and all signs of the spiroptera had vanished.

The importance of this work lies in the fact that there would now appear to be a method of starting cancer *de novo* and so of studying it from its origin. Another parasite, cysticercus, has for many years been associated with the appearance of sarcomata in mice. Only one rat, of 2,500 examined at Copenhagen, was found to show a cysticercus sarcoma, and this curiously enough was one of Fibiger's animals. It was also infected with spiroptera and had, in addition to a sarcoma, a carcinoma of the stomach. Thus two different worms were able in the same animal to cause two different and well-

recognized types of tumour. At least 90% of sarcomata in the livers of rats are said to contain cysticercus, and in these animals sarcomata far outnumber carcinomata. In mice, on the other hand, though the cysticercus is frequently found in the liver, sarcomata are never found. This fact must be emphasized as showing how dangerous conclusions on the subject may be. On the other hand there can be no doubt that Fibiger's experiments do throw a new light on a very baffling problem.

See *Comptes Rendus de la Société de Biologie*, vol. lxxxviii., no. 16; *British Medical Journal*, May 15 1920 and June 5 1920.

(R. M. Wl.)

**CANEVA, CARLO** (1845— ), Italian general, was born at Tarcento (Friuli) in 1845. His birthplace being under Austrian rule until 1866, Caneva was educated at the Military Academy at Wiener Neustadt, but he entered the Italian army on May 1 1866. In 1892 he attained the rank of colonel on the general staff, and he was promoted to major-general two years later. He served in the African campaign of 1897, and in 1903 was promoted lieutenant-general. After commanding a division and an army corps, he became sub-chief of the general staff and in 1910 he was chosen to command an army in the event of war. The event came a year later, with the outbreak of war between Italy and Turkey; Caneva commanded one side in the much-discussed manoeuvres of 1911, his opponent being Cadorna, and the former was declared victor, though military opinion was divided. In any event, it was probably owing to the result of the manoeuvres that the selection to command the Tripoli Expeditionary Force fell upon Caneva rather than Cadorna. Caneva was given a thankless task. He was sent to occupy the coast towns, in the belief that the Arabs and Berbers would welcome the Italian occupation, and that the Turkish garrison unsupported by the tribesmen could be brought to surrender with little or no difficulty. He was speedily undeceived, and the initial overconfidence was succeeded by a period of excessive caution. For a time Caneva could do nothing, as he had no transport, and later on he was hampered by orders from home which forbade risks or heavy casualty lists. But even allowing for his handicaps Caneva was generally considered to have carried the waiting policy too far and clung to it too long. Although the late spring and summer of 1912 saw a change, and several important successes were gained, Caneva was recalled to Italy on Sept. 2, and shortly afterwards retired. He presided over the commission of inquiry into the Caporetto disaster in 1917. (W. K. McC.)

**CANTEEN**, a generic term for the building and organization which provides for the soldier's recreation and extra-regulation comforts. The use of this term has naturally been extended to cover similar buildings and organizations which provide the same services for factory workers and others who live and work together in considerable numbers; but here it is sufficient to deal with canteen organization and its results in the British and American armies during the World War.

The effort which was made in most of the armies in the field to mitigate campaign hardships by canteen organization reached its highest point in the American and the British armies. The American organization was chiefly in the hands of the American Y.M.C.A. (which was also entrusted with the educational work in the American army). The British organization was, as regards the home camps, chiefly in the hands of the army and navy canteens, the Y.M.C.A., the Church Army and the Salvation Army; as regards the armies abroad in the hands of the Expeditionary Force canteens and the private agencies mentioned, whose personnel in the field were given the right to wear uniform and to use military transport and billets.

As regards the British army, the Expeditionary Force canteen in 1918 was a vast organization operating in every theatre of war. It provided for officers and men cheap shops, good rest and recreation centres, and for officers excellent hotels. From the Expeditionary Force canteens the soldier could buy cigars, cigarettes, chocolate, sweets and all kinds of canned goods, duty free, and at prices far lower than those of the London shops. Whisky, wine and beer could be bought duty free, under some restrictions.

The Expeditionary Force canteens organization was formed first in 1915. Its operations commenced in France, but were subsequently extended to all theatres of war. The undertaking was from its commencement conducted by Sir Alexander W. Prince and Colonel F. Benson. In due course the organization took on various other

functions, but its canteen business alone made it by far the biggest shipping concern in the world. The "supplies and shipping" department of the Expeditionary Force canteens had for canteens alone an average annual turnover of approximately £20,000,000. From three to four thousand different articles appeared on the stock sheets. The tonnage handled was enormous, and during the month of Nov. 1918 it reached nearly 12,000 tons, representing 320,000 cases, in France alone. The record week was that ending March 16 1918, just prior to the great German offensive, when 3,643 tons of canteen supplies were landed, and a turnover amounting to £400,000 was reached. The tonnage off-loaded for the year 1918 was 121,000 tons, and comprised over three million packages. The growth of the total sales at canteens and depôts in France is shown by the following figures (by half-years ending at the dates mentioned):—

June 1915 . . . . .	£ 120,000	June 1917 . . . . .	£ 6,000,000
Dec. 1915 . . . . .	700,000	Dec. 1917 . . . . .	8,000,000
June 1916 . . . . .	2,000,000	June 1918 . . . . .	9,500,000
Dec. 1916 . . . . .	4,000,000	Dec. 1918 . . . . .	9,500,000

Profits were kept to a strict minimum, and by a happy decision prices for the same goods were the same on every front.

Another feature of the Expeditionary Force canteen work was that it served the man in the fighting line first and the man in the rear zone second. When in 1917-8, owing to the shipping position, Expeditionary Force canteen supplies had to be restricted, and the complaint came that what supplies did come over were largely absorbed at base and on lines of communication, and the men in the front line got very little, the quartermaster-general ordered that: (1) certain luxuries which were in very short supply should go only to the front area canteens and not at all to the base; (2) other goods should go in the proportion of four to front areas and one to the base. Beer was a special problem, as its bulk made demands on tonnage which could no longer be admitted. G.H.Q. did not like the prospect of stopping the soldiers' beer, and accordingly the P.M.C.'s department took over, in part or in whole, breweries in the army areas and arranged to brew beer locally, importing only the malt and the hops from England. American canteens were, of course, "dry."

The work of the British Expeditionary Force canteens in France was the most important as regards figures, but probably on the remote fronts it was of greater value in showing the troops that they were still in touch with home. In Egypt and Palestine the organization pushed forward its comforts far into the desert on camel-back, and on these fronts about £5,000,000 a year passed over its counters. On the Mesopotamia front there were 37 canteens, the most remote being at Khanjain (in Persia); and one flourishing branch was at Qurna, the legendary site of the Garden of Eden, where soldiers could buy most of the fruits of the earth in canned form. A canteen boat was kept plying on the Tigris. The Salonika front and the British front in Italy were also well supplied with canteens.

The work of the British Expeditionary Force canteens was sometimes carried on under conditions of some danger, as forward canteens were never withdrawn on account of hostile shell-fire unless it became very intense. During the German advance in the spring of 1918 the Expeditionary Force canteens lost very heavily in goods as the enemy came forward and the canteens had to be evacuated. The stocks of spirits were destroyed, other goods given away to the troops as they passed, and the residue destroyed by fire.

The British Y.M.C.A. during the war spent a gross of £21,000,000 on canteen work for British troops and war workers. Of this sum £17,300,000 represented refreshments sold. The Y.M.C.A. provided "dry" canteens, amusements and stationery, and in rear areas was in charge of lecture and other educational work. Its free gifts to the troops were valued at nearly £1,000,000, and all profits made at canteens were put back into war work. After the Armistice, when public subscriptions to the Y.M.C.A. fell off, the British War Office, recognizing the importance of its work, advanced to it £700,000 to enable it to continue operations during the period of demobilization. Subsequently £590,000 of this was made a free gift. Y.M.C.A. work was carried on in every theatre of war.

The Church Army provided nearly 2,000 canteen centres for the British army, of which about one-half were in France and others in Mesopotamia, Egypt, Malta, Salonika, Gallipoli, India and at naval bases.

(F. F.)  
When the American army arrived in France, the U.S. Red Cross had already established and was operating a canteen system for the French army. This system was extended, the existing organization naturally forming a base, since the American Expeditionary Force was superposed on the forces already in the French zone, and at first used the same lines of communication. Military canteens were also established by the troops themselves. But by far the greater part of the canteen work in touch with troops was carried out by the American Y.M.C.A., which, by an army order of Sept. 6 1917, took over responsibility for canteen work generally. The order forbade the establishment of a military canteen where a "Y" was available, and finally over 1,200 canteens or recreation halls were in operation. Affiliated to the Y.M.C.A. and working in connexion with its canteen system were library, educational, athletic and entertainment organizations in profusion. The Y.M.C.A. also cooperated in the work of the French "Foyer des Soldats." On a smaller scale, similar work was done by the "Knights of Columbus."

CAPELO, LUIGI (1859-- ), Italian general, was born April 14 1859. He entered the infantry, and his career till he became a general officer was passed in this branch of the service. During the Italo-Turkish War he served in Cyrenaica, and as a major-general he took part in the operations round Derna, commanding a column in the final action of the war in Oct. 1912. In 1913 he was promoted to lieutenant-general. He commanded the 25th Sardinian Div. during the early attacks upon the Carso in the summer of 1915, and the VI. Corps opposite the southern part of the Sabotino-Podgora bridgehead in Sept. 1915. In Aug. 1916, Capello, whose command had been increased to the strength of six divisions, conducted the attack which stormed the bridgehead and led to the capture of Gorizia. A difference of opinion between Cadorna and Capello led to the latter's transference to the Trentino front, where he commanded successively the XXII. and V. Corps in the Asiago uplands. In March 1917 he returned to the Julian front as commander of the "Gorizia Zone" (VIII., VI. and II. Corps), in which capacity he conducted the first phase of the Italian offensive in the following May. In June Capello was given command of the II. Army, which extended from the Plazzo valley to the Vipacco, and in Aug. he directed the attack on the Bainsizza plateau. There was a difference of opinion between Cadorna and Capello regarding the development of the action after the initial success, and this difference became more serious when Cadorna decided to stand on the defensive in view of the forthcoming enemy attack. Capello wished to go on attacking, and it is difficult to avoid the conviction that his belief in his own method of meeting the coming threat prevented him from cooperating whole-heartedly in the plan of his chief. Capello fell ill shortly before the enemy attack was launched and only returned to his post on the very eve of the battle. He was quite unfit for the strain of command, and had to resign after two days. When sufficiently recovered in health he was given the task of creating the new V. Army out of units broken and disbanded by the retreat. To this task he gave all his energy, and in it he achieved remarkable results, but in the spring of 1918, on the constitution of the Caporetto Inquiry Commission, he was put on half-pay, and in July he was retired. After his retirement Capello wrote two books, a reply to the criticisms of the Inquiry Commission, entitled *Per la Verità*, and *Note di Guerra*, a work which deals with the Italian campaign as a whole but especially with those operations in which he played an active part. He also took some part in politics, presiding at various important Nationalist and Fascist meetings.

CAPE PROVINCE (see under CAPE COLONY, 5225), the largest of the provinces of the Union of South Africa. At the 1911 census the inhabitants numbered 2,564,905, of whom 583,877 were whites and 1,982,888 coloured, an increase since 1904 of 8.33% in the coloured pop. but of only 0.45% in the white.

Among whites, females exceeded males by 43,623; among the coloured people by 63,928. In 1918 a census of whites only was taken. They then numbered 618,825, an increase of 6.41% over 1911, affording an example of the abnormal fluctuation to which the white pop. of S. Africa is subject. Of the 1911 pop. 96.47% of the white and 44.20% of the coloured inhabitants returned themselves as Christians. The coloured inhabitants were divided into Bantu 1,619,030, Asiatic 7,690, and "mixed" and other coloured 454,950. This last category included a few thousand Hottentots and Bushmen, but the majority were the mixed white and black "Cape Boy" class commonly called "coloured" in distinction from "natives." In 1911 of the whole coloured pop. 24,000 were engaged in professions or commerce and 93,000 in industries. Many districts of the province are arid or semi-arid, and over most of its area there are not more than seven persons per sq. mile. The pop. is mainly found in the fertile S. and S.E. coast regions, and of the Bantu in 1911 no fewer than 871,062 lived in the Transkeian territories, where there were 54 persons to the sq. mile. These Bantu are still heathen and nearly all are agriculturists. There were in 1911 only five towns with over 12,000 inhabitants, namely Cape Town (161,750), Kimberley (44,433), Port Elizabeth (37,063), East London (24,606) and Grahamstown (13,830).

Administration.—The affairs of the province are in the hands of a provincial council, elected for three years and not subject to dissolution save by effluxion of time. The qualifications for electors and members of the council are the same as for the members elected by the province to the House of Assembly

(save that a provincial councillor must live in the province in which his constituency is situated). Under this provision in the Cape province natives and other non-white races possess the provincial franchise. At the 1917 registration there were 150,000 white and 30,000 coloured electors. The number of constituencies are also the same as for Parliament.<sup>1</sup> The provincial council has powers of legislation on subjects specifically assigned to it by the Act of Union and on subjects delegated to it by the Union Parliament. These powers include direct taxation within the province in order to raise revenue for provincial purposes and the control of municipalities and other local bodies, and of "elementary education"—which embraces all education other than university. Its enactments are called ordinances, and no ordinance is valid so far as it may be repugnant to an act of the Union Parliament. In short, though a legislative body, the provincial council exercises no authority which Parliament cannot revoke. There is no separate judiciary, or police force, or civil service, nor any separate departments of general government. Moreover, harbours and railways are under the control of the Union Parliament.

The provincial council is presided over by a chairman, elected from its members; and the council also chooses an executive committee of four, who need not be members of the council. The chief executive officer is styled administrator and is chosen by the Union ministry; the administrator is appointed for five years and is irremovable. A provincial auditor is also appointed by the Union ministry and is removable only for reasons which must be submitted to the Union Parliament. The Union ministry likewise appoints an attorney-general as legal adviser.

**Revenue.**—Under provisions of the Financial Relations Acts of 1913 and 1917 the Union Government pays to the provinces an annual subsidy amounting to one-half of the estimated normal provincial expenditure for the year. This financial dependence of the provinces on the Union Government emphasizes their subordinate position and is a guarantee against any tendency in the provinces to go beyond the scope of local affairs.

The subsidies paid to the Cape provincial council varied from £862,000 in 1913-4 to £999,000 in 1917-8; the revenue raised by the province was £405,000 and £426,000 respectively in the years named, but had been as low as £316,000 in 1914-5. Transfer duties and licences (trade, liquor, motor, etc.) were the chief sources of revenue. The chief item of expenditure is on education; thus in 1913-4, out of a total expenditure by the provincial council of £1,142,000, the sum of £853,000 was spent on education. In 1917-8 the figures were—total expenditure £1,477,000; on education £1,150,000. In 1920-1 the cost of education had risen to £2,163,000, the number of children on the school rolls being 288,000, an increase of about 50,000 since 1913. In primary schools education is free.

**History.**—Politically the Cape province has had no separate history since the establishment of the Union in 1910. Parties in South Africa are not divided on provincial lines; it may, however, be recorded that the majority of the Cape members of Parliament have favoured the maintenance of the British connexion and the fusion of Dutch and British interests. In the rebellion of 1914 De Wet in his effort to reach German S.W. Africa entered the province and was captured at a place 110 m. W. of Mafeking. In domestic concerns the province showed a progressive attitude, notably in its care for education. Bilingual requirements gave rise to no great difficulty, the provincial council having passed an ordinance in 1921 providing that the medium of instruction up to standard IV. should be the "home language" of the child. Provincial spirit remained keen, but the white inhabitants of the eastern district, who are largely (if not mainly) of British descent, look to the Transvaal and Free State for trade, while with the people of the western part of the province (who, Cape Town apart, are predominantly of Dutch origin) they have practically no commercial intercourse.

Sir N. F. de Waal, who had been colonial secretary in the last ministry of Cape Colony, was the first administrator, and he guided the province through the period of change caused by the

establishment of the Union. He served for two successive periods and was reappointed for a third time in 1920. There was no introduction of party politics in the provincial council (as happened in the Transvaal province).

The period 1910-20 witnessed considerable industrial and agricultural development and a significant growth of Ethiopianism and trade unionism among the native and coloured people. These were not features peculiar to the Cape province, though, as the Cape contained a larger proportion of educated natives and there was no colour bar to the exercise of the franchise, the province was the chief centre of native agitation for social and industrial rights. An indication of the activity of the Anglican Church was the creation of two new dioceses, George (1911), and Kimberley and Kuruman (1912).

An event which caused a deep impression on the public mind was the epidemic of influenza in the autumn of 1918. It was estimated that a quarter of the inhabitants suffered and for three or four weeks business in the cities was dislocated, so numerous were the victims. (F. R. C.)

**CAPE, BERNARD EDWARD JOSEPH** (1854-1918), British novelist, was born in London Aug. 30 1854 and educated at Beaumont College. He was a nephew of John Moore Capes, a prominent figure in the Oxford Movement, and was brought up a Roman Catholic. Originally intended for the army, he was prevented from taking a commission by a mistake as to the age at which he should have presented himself for examination. He was then put into a tea-broker's office and for some years struggled with uncongenial work, finally abandoning it to study art at the Slade School, London. In 1888 he joined the publishing firm of Eglington & Co. and succeeded Clement Scott as editor of *The Theatre*. In 1892 the firm came to an end, and he made an unsuccessful experiment in rabbit farming. But in 1896 he won a prize offered by the *Chicago Record* for a novel of mystery and henceforth devoted his energies to fiction. His novels, 36 in number, were mostly tales of adventure, some of them historical. They include *The Lake of Wine* (1898); *From Door to Door* (1900); *A Jay of Italy* (1905); *A Rogue's Tragedy* (1906); *The Story of Fifine* (1914) and *Moll Davis* (1916). He published also a volume of verse. He died at Winchester Nov. 2 1918.

**CAPE TOWN** (see 5-252), capital of the Cape province, and seat of the legislature of the Union of South Africa. In 1913 Cape Town municipality was greatly enlarged by the absorption of the suburban municipalities of Green Point and Sea Point, Woodstock, Maitland, Mowbray, Rondebosch, Claremont, Kalk Bay and Muizenberg, with Camps Bay and other adjacent areas. Cape Town thus extends across the Cape Peninsula from Table Bay to False Bay—a distance of 17 m.—and covers an area of over 59 sq. miles. Wynberg (between Rondebosch and Muizenberg), though retaining a separate municipality, is a suburb of Cape Town. The pop., including suburbs, 170,083 in 1904 (44,203 whites), was 161,579 in 1911 (85,442 whites and 76,137 coloured). In 1918 the white pop. was 99,693; the coloured (estimate) 82,000.

Business, professional and official life is concentrated in Cape Town and at the docks. The chief feature of the decade 1910-20 was, however, the development of the suburbs, an enterprise in which the municipality took the lead. Cape Town in the season (Oct.-March) is the principal pleasure resort of South Africa.

On the sea front at Table Bay a promenade pier (1,500 ft. long) and esplanade (1,000 yd.) were completed in 1914. The pier replaces the old central jetty and is in a line with Adderley Street and Government Avenue, the principal thoroughfares. To the Houses of Parliament, in Government Avenue, a new wing was added (1920). At the foot of the Avenue is the site of the National Art Gallery. The Max Michaelis collection of Flemish and Dutch masters—including examples of Rembrandt, Frans Hals, Jan Steen and Vandyck—presented to the Union Government in 1912, is in "the Old Town House," in Greenmarket Square. The building, a fine example of colonial Dutch 18th-century architecture, was transferred to the Government in 1916.

Rondebosch, 3 m. from the centre of the city, is the chief residential suburb. It contains Groote Schuur, formerly the property of Cecil Rhodes; since 1910 the official residence of the Prime Minister of the Union. In 1918 on the incorporation of the South African College (founded at Cape Town 1829) as the university of Cape Town, a site for new buildings—to replace those in the centre of the

<sup>1</sup>The particulars here given of provincial administration are the same in all four provinces (the Cape, Natal, Orange Free State and Transvaal) save that the minimum number of members of a provincial council is 25, whereas Natal and the Free State return fewer members to Parliament.

city—was granted in the grounds of Groote Schuur; £500,000 towards buildings and endowment being provided mainly from bequests by Sir Julius Wernher and Mr. Alfred Beit. In 1912 a Rhodes memorial was unveiled at Groote Schuur by Earl Grey (a former director of the Chartered Company). In front of the memorial, a granite temple in the Doric style approached by a flight of steps, is the equestrian statue of "Physical Energy" by G. F. Watts. In the temple is a bust of Rhodes. Not far from Rondebosch, at Kirstenbosch, are the National Botanical Gardens, established 1913. In Oct. 1918 Cape Town suffered from a great epidemic of influenza, 7,000 deaths occurring in three weeks. In the autumn of 1919 influenza, but in a milder form, again ravaged the city.

Cape Town has since 1913 ranked second in importance to Durban among South African seaports, but it is first for passenger traffic. The shortage of shipping did not greatly affect Cape Town until 1918. In that year the total tonnage of cargo landed, shipped and transhipped at Table Bay was 1,070,000, the average for the three previous years being over 1,440,000 tons. In 1918 the net tonnage of shipping entering Cape Town was 2,347,000—British, 1,662,224; foreign, 684,776. In 1919 British shipping had increased to 2,253,000 net tons, while foreign shipping fell to 424,000 net tons. In 1918 the ratable valuation of Cape Town was £21,258,000, municipal revenue £778,000 and indebtedness £4,893,000. In 1919 the ratable valuation was £23,343,000.

Direct communication with the railways of the S.W. Protectorate (ex-German S.W. Africa) was opened in 1915 and in 1918 the railway going north had reached Lualaba (Upper Congo) at Bukama, a distance of 2,598 m. from Cape Town without break of gauge. An aerodrome on the trans-Africa air route was laid out at Young Field, Wynberg, in 1919, and the first airmen to cross the length of Africa, Lieut.-Col. Sir H. A. Van Rynveld and Flight-Lieut. Sir C. J. Q. Brand, arrived at Wynberg on March 20 1920. A wireless station at Slang Kop, 18 m. S. of Table Bay, was opened in 1911. It has a normal range of 450 m. by day and 1,500 by night.

**CAPITALISM.**—The meaning of "capital," in economics, is analyzed in the earlier article under that heading (5,278). But the working of "capitalism" or the "capitalistic system," as such, had by 1921 become so highly controversial a question as to require here more detailed examination.

The term "capitalism" is generally applied to the system under which the instruments of production are the property of private owners, who usually employ managers and manual workers to carry out production by their means. By production we must include, if this definition is to be correct, the whole of the process by which raw materials are brought to the place of manufacture and worked up into manufactured goods, and the manufactured goods are then distributed to the places where they are wanted and sold to the final consumer through the hands of retailers. The instruments of production thus include not only the land, factories, tools and machinery, and other equipment used in actual manufacture; but the railways, ships and other means of transport, and the warehouses and shops through which the goods finally pass to the consumer.

**Private Ownership.**—Private ownership of the instruments of production has not been universal in man's economic history, but it has been generally adopted by progressive communities. When "Adam delved and Eve span," they were "capitalists" in the sense of owning a spade and spinning-wheel and using them for purposes of production, but they used these tools themselves and for the purposes of supplying their own needs. And at a very primitive stage of society, this simply individualistic system by which the capitalist used his own tools and worked for his own needs may be presumed to have been common. When, however, by the development of a wider society the division of labour and the exchange of goods between one member and another of the community began to be practised, the new feature arose by which the producer made and grew goods not only for his own use, but to be exchanged for goods grown or produced by others; and consequently he had to produce something which somebody else wanted if he wished to provide for his own needs to his own satisfaction. Thus we find in the Middle Ages artificers and craftsmen owning their own tools, that is to say, their own capital equipment, and working to produce articles such as armour, farming implements and clothes which they exchanged in return for the food produced by the farmers who would only take the goods produced by the artificers if they were of a kind which pleased their fancy. It is important to note at the outset that the capitalist, whether he

works with his capital or sets others to work with it, must invariably direct the work done so as to suit the wishes of a buyer which may or may not be expressed before the making of the article is begun. Capitalism, in the sense of a private ownership of tools and equipment, thus dates from the earliest organization of human economic activity. As soon as a savage had given time and labour to fashioning a weapon with which he could more easily kill or catch animals that he hunted for food or clothing, he had become a capitalist, he had made something which would help him to provide for his own needs and those of his dependents more easily, or by which he could more easily acquire commodities which he could exchange against those owned by other members of his tribe. But capitalism in the modern sense, and as defined above, is usually said to date from the last quarter of the 18th century, when what is called the "Industrial Revolution" began, and by the inventions of machinery and the use of steam industry was reorganized on a new basis.

**Capitalist and Worker.**—Owing to these developments it was no longer possible for the workman using his own tools and working in his own home to compete with workmen who were assembled in a great factory and worked with machinery which it would not have been possible for their collective resources to buy. Thus arose the distinction between the worker and the capitalist, which had in effect already made considerable progress before the introduction of machinery, but was so rapidly developed after it that modern capitalism is usually so dated. By this system the worker, by which is generally meant the manual worker, is said to have been divorced from the ownership of his tools. The scale of industrial organization became so great that it was only possible for men of great means, or for a collection of people of considerable means, to provide the necessary land, factories and equipment for its working, and also to buy the large quantities of raw material required, to pay the wages of the multitude of workers and managers, and to finance the other expenses during the process of production and up till the time of payment by the final purchaser.

Originally it was usual for the owners of these factories, whether individuals or small bodies working in partnership, to act as managers of the whole concern. The capitalist was at once owner of the factory and machinery, provided the money needed for the financing of the industrial process, and managed and organized the whole enterprise. He was responsible for buying raw materials, paying wages and selling the product to the greatest possible advantage to the other capitalists, merchants and middlemen, who passed it on until it reached the final consumer; he, singly or in partnership, took all the risk of loss involved if the product failed to suit the caprices of the buying public, and took all the profit; if any, that was earned from the enterprise. This profit thus included interest on his money invested, the payment of his salary as organizer and manager, and any extra bonus which his skill might enable him to earn as compensation for the risks run.

**Joint Stock System.**—As industry developed on a still greater scale it was not possible for this comparatively simple organization to be maintained. When it became a question of building railways, requiring hundreds of millions to finance them, no individual or partnership could supply the necessary funds, and so the joint stock system, which had already been developed on a small scale in mediæval times, was extended so successfully to industry that the greater part of our industrial activity is now carried on by means of joint stock companies, the extension of which was enormously facilitated by the introduction of the principle of limited liability. Thus the position of the capitalist has become still further defined and differentiated. It is certainly probable that the managers of most of our great industrial concerns hold a certain number of shares in the business which they conduct, and to that extent may be described as capitalists, but the two functions are now quite distinct. The capitalist pure and simple lends money to industry or invests it in industry, using industry in the widest sense of the word to include transport and commerce. The actual management is carried on by officials appointed specially for this purpose under the supervision



of a committee of the shareholders who are called directors, who are paid comparatively small fees for the usually rather nominal supervision which they exercise over the more highly paid work of the managers and staff, and for guiding the financial policy of the company with regard to dividend distributions and so on: The capitalist is either a creditor or a shareholder in the company which is formed by public subscription to carry on the industry in question; all that he does is to lend to industry the money which is essential in order that the industry may acquire all the tools, machinery, buildings, raw materials and other equipment necessary for carrying on the work, and to pay the wages of the wage-earners and managers during the initial period before the company's operations have produced something that can be sold to supply money for wages, the purchase of further raw materials, and the upkeep of the plant. The business of management is carried on by highly paid experts, and the capitalist's sole claim to a share in the earnings of the company is based on the fact that he has provided the money which was essential for its beginning and for its further growth. He earns his reward first by placing this money at the disposal of industry instead of spending it on his own immediate enjoyment; and secondly by risking the loss of part or the whole of his money if the industry should fail.

*Capital Financing.*—A highly ingenious machinery has been developed for the provision of money for industry and commerce by the process of investment in the securities of public companies, and for the turning of these securities back into money by their sale in markets known as stock exchanges. Joint stock companies are formed either to carry out some new enterprise, or work some new process, or to take over an existing business which has hitherto been carried on by private partners. An appeal is therefore made to the public to subscribe to the securities into which what is called the company's capital is divided. As so often happens in these matters of business, great confusion arises owing to the use of the same word in different senses: the capital of industry has hitherto been referred to in the course of this article as the tools, buildings, and other equipment by which industry works; but the capital of a company generally means the money that it receives from those who subscribe to the securities that it offers. If we take the case of a company formed to work a coal mine, and suppose that the original promoters consider that £2,000,000 will be necessary for them to make a proper start on the enterprise, then these two millions will be the original capital of the company, subscribed to it by investors who receive, in return for their money, securities which give them claims upon it for interest, dividends and repayment either at a fixed date or in the event of the company's liquidation. These claims take the form of securities issued by the company. They would probably be divided into several categories; there will be a debenture stock, perhaps carrying mortgage rights and entitling the holders to a fixed rate of interest, and most probably to repayment in full or at a premium at some future date. In case of default in payment of their interest or repayment of the sums promised at the due date, the debenture-holders would be entitled to take over the property and put it in the hands of a receiver. They are thus not shareholders in the company but its creditors, and, strictly, securities issued in this form of a mortgage or debenture are not part of a company's capital but its debt. Ordinary business parlance, however, usually includes mortgages and debentures as part of capital. The share capital is usually divided into preference and ordinary, the preference shareholder being entitled to a fixed rate of interest which has to be paid to him before the ordinary shareholders receive anything. This preference right among English companies is usually what is called cumulative, that is to say, if the preference dividend is not paid in any year all arrears have to be paid before the ordinary shareholders receive any return on their investment. In America, however, where the term "preferred" rather than "preference" is more usual, this cumulative right is not so common as it is in England; in some cases also preference shareholders are entitled to a further participation in profits after a certain rate of dividend has been paid to the ordinary share-

holders. The ordinary shareholders as a rule take what is left of the profits after the claims of debenture-holders and preference shareholders have been satisfied. If the company is successful they thus earn higher rates on their investments than go to the holders of other forms of securities. If the company fails they receive little or no profit, and the claims of the mortgage and preference shareholders have to be satisfied in full before the ordinary shareholders get any of their capital back in case of liquidation. Almost infinite variations, however, are performed on the theme of capital arrangements, with income debentures, cumulative ordinary shares with a fixed rate of dividend, deferred shares, founders' shares and so on. And some companies issue no securities except ordinary shares or stock.

By this ingenious system the amount of risk involved by industrial investments can be varied to suit the taste of the individual investor, but generally with the result that the less risk he takes the less return he is entitled to on his investment. The holder of a debt which is a first charge on a long-standing and well-managed industrial or transport concern comes as near as he can to eliminating risk altogether from an industrial investment. It consequently follows that this kind of security is originally issued and is dealt in on the markets of the world on terms which give their subscribers or purchasers a comparatively low rate of interest. The preference shareholder, who is not as well secured as the debenture-holder, but ranks before the ordinary holder, also stands midway between them in the matter of risk and the matter of return. Before the World War, for example, if a well-known English brewery company were appealing to the public for subscriptions it would probably have been able to issue its debenture stock in return for a promise of 4% to 4½%, its preference shares on the basis of 5% to 6%, while its ordinary shares, if they were to expect a ready response from the public, would have had to show a probable return of 7% or 8%.

When the prospectus has been issued and the public subscription has been carried out, the securities offered are then quoted on the Stock Exchange at prices which will vary with the opinion held concerning the present and prospective prosperity of the company, and also in accordance with the general rate ruling for the use of money, which varies like the price of everything else in accordance with supply and demand. At a time when there is a great demand for capital for the development of new and old enterprises all over the world the rates that have to be offered in order to tempt subscribers will be forced up by competition, and consequently the price of existing securities will tend to fall owing to sales by their holders, who are tempted by the more alluring rates offered by new ventures. If, on the other hand, enterprise is slack and new creations of capital are comparatively rare, then the pressure of accumulating savings for investment in existing securities will force their prices up and so lower the rate of return which an investor may expect.

By this means capitalism has devised a highly efficient machinery through the mechanism of the Stock Exchange by which anyone who has lent money to industry, as conducted by an ordinary joint stock company, is able in normal times to realize his holdings and turn them into cash by sale on the stock markets. If the company in which he has invested has been successful and is fulfilling, or more than fulfilling, the anticipations held out in its prospectus, he will be able to sell his holdings at a comfortable profit, especially if he is an ordinary shareholder. The prices of securities with a fixed rate of interest or dividend naturally fluctuate less than those of the ordinary shares, but even in their case the success or failure of the company has a very considerable influence upon the price for which they would be sold. Many popular securities have a world-wide market and can be dealt in in all the financially civilized countries; and this development of securities readily marketable at publicly quoted prices has been a great assistance to the growth of international banking.

*Freedom of Enterprise.*—By the development of this machinery it is possible for the association of small contributions by a large number of people with comparatively small means to carry out enterprises on a colossal scale, and to pour the stream of investment into all the countries of the earth, fertilizing its backward

places and bringing forth a vigorous crop of goods and services and making the world into one great market united by the bonds of industry and finance. In many large industrial companies nowadays, shares of £1 each or less are now issued, and in this way capitalism has been democratized to an extent which a hundred years ago would have been thought quite incredible. Enormous enterprises, the most obvious example of which are the Egyptian pyramids, have been carried out in the past by means of slave labour employed by tyrants; and the Roman roads and aqueducts are another example of what could be done by the application of state management to a highly disciplined people. But the most notable achievement of modern capitalism is that it has vastly increased the productive power of mankind by making use of the resources of thousands of individuals voluntarily subscribing their money in the hope of profit which can only be earned if the consuming public will voluntarily buy the goods and services produced. Thus capitalism is essentially based on freedom—the freedom of the subscriber in risking his money, and the freedom of the consumer in giving or withholding his custom and the profit that it makes possible. It opens its pocket freely—sometimes too freely—to anyone who can persuade it that an enterprise is likely to be profitable. Under it the way is open from the bottom of the ladder to the top for those who have the diligence, determination, capacity, and luck to climb; and they can climb only by producing something that will fetch a good price in the market of their fellow-creatures' needs and desires. The freedom of capitalism is thus limited by the consumers' veto. It can only succeed by pleasing the ultimate buyer and cooperating with the consumer by satisfying his needs.

*Prejudice against Capitalism.*—Nevertheless, capitalism is perhaps now more virulently criticized than any other human institution, largely owing to the belief that it involves robbery of the wage-earning classes by those who place the means of production at their disposal and pay them wages for working upon them. The prejudice against capitalism could not be as wide as it is unless there were some foundation for it; and in the first half century in which modern capitalism was active the exploitation of the wage-earners through low wages, long hours, disgraceful working conditions and ruthless dismissal at any time when it seemed more profitable to the employers to reduce output, was carried on to an extent which is now seen to have been criminal. This seems to be the reason for the astonishing hold which the works of Karl Marx have exercised upon those of the wage-earners who are attracted by his revolutionary doctrines. It is admitted by Marx's most fervent admirers that most of his theories were wrong; that many of his assertions were incorrect, and that most of his forecasts have been proved to be baseless. But the fact remains that he was able to describe a state of things in English industry on the authority of official documents which was entirely disgraceful; and the wage-earners, who probably seldom study his works but usually rely upon a summary of their contents, find that with regard to the exploitation of the worker he has a solid basis of facts which are known to them by the tradition they have received from their forebears who worked under the miserable conditions that he describes.

It need not be said that since the middle of the 19th century there has been a very great change in this respect, thanks to Factory Acts, the growing strength of the trade unions and a more humane and sensible spirit among the employers; and it is interesting to consider why it should be that the employers of the first half of the 19th century, most of whom were probably quite human and kindly people who thought that they were doing their best according to their lights, should have treated those who worked for them in a manner which now seems to us so inhuman. In the first place, we must remember that a very large number of them in those days were men who had risen from the ranks and had themselves had to suffer the hardships which they imposed on others, and, since they had come through them successfully, did not see any reason why anything better should be done for those who worked under them. But a further excuse has to be found for the men of noble lineage and high intellectual attainment, who also suffered barbarities to be perpe-

trated in the mines and factories which they owned; and this excuse is provided by the pessimistic utterances of economists such as Adam Smith, Malthus and Ricardo, who stated or implied that the pay of the wage-earners could not rise above the level required to maintain them as efficient workers; and that any attempt to improve their condition would simply lead to an increase in their number by procreation which would inevitably defeat the efforts of those who tried to improve their lot. With doctrines such as this in the air, and expounded by high authority, there is some reason to excuse wickedness or mistakes which have cost the industrial world dear by the legacy of bitterness and suspicion which they have left behind.

*Capitalism and Wages.*—It is also true that too many modern capitalists are still apt to resent any attempt on the part of the wage-earners to improve their lot by demanding better wages and shorter hours of work, and do not seem able to perceive how entirely short-sighted such resentment is. When the wage-earners are confronted, every time they ask for an improvement, by demonstrations on the part of capitalists that its granting would immediately ruin the industry in which they are concerned, and when nevertheless they insist upon the improvement and then find that the industry is by no means ruined but goes ahead to fresh prosperity, it is natural and inevitable that the wage-earners should be filled with a deep distrust of any statement made by their employers concerning what is and what is not possible to be granted by industry. And it is not only owing to this distrust and bitterness that this policy on the part of employers has been short-sighted. They might have recognized that for all the great staple commodities the wage-earning classes are already, and will be to an increasing degree, the most important consumers; and therefore that those who are engaged in making any product of general use will find it to their own interest that the general level of wages should be high so that there should be a good and steady demand for the product which they have to sell. It may be true from the point of view of the next balance sheet that it will pay any individual employer to pay as low wages as possible to his workmen, but he ought to recognize that what he needs is that all the workers in all other industries should be paid as well as possible and that he, by paying his own workers low, is doing what he can to depress the general level and so defeat his own objects in securing a market. This is quite apart from the wider question how far low wages involve cheap production. Up to a point, and as long as the wage-earners can be induced to give a fair day's work in return for their wage, experience has shown—especially in America—that high wages are an important item in cheapening production. Lately, and especially since the war, experience has shown that increases of wages have been followed by absenteeism on the part of the workers, and slack work while they are at work. Up to this point it should be the ambition of enlightened employers to pay the highest wages that the industry can stand. Capitalism increases its own efficiency and those of its wage-earners up to the point at which it enables them to improve their health and efficiency by paying higher wages; but when, as sometimes happens, the wage-earner simply has no use for any increase in his money receipts, then higher wages merely mean that he works fewer days in the week. The only remedy for this deadlock seems to be the education of the worker in the habit of accumulating for himself out of any surplus that he earns. If the wage-earners could thus be induced by accumulation to become capitalists themselves, it is possible that an improvement, the extent of which it is quite impossible to measure, might be secured in the relations between labour and capital.

*Charges Examined.*—If then we admit, as we must, that the early days of modern capitalism were marked by serious injustice inflicted on the manual workers, and that even to-day employers are much too ready to resist demands on the part of labour for improvements in its conditions, it must at the same time be remembered that these faults in the working of capitalism do not necessarily imply any essential injustice in the system or any blot upon it which cannot be improved out of existence. If the early employers, taking advantage of the unorganized state

of their workers, paid them too low for too long working days under working conditions which were a disgrace, it is also true that these conditions are in most industries, especially the best organized and most prosperous industries, a thing of the past. Moreover, the charge against capitalism, brought against it by the most extreme of its critics, is not merely that it has been in the past or is now unjust to those who work for it in the matter of hours and wages, but that the whole system is essentially based upon robbery, that the whole product of industry is really due to the exertions of labour, and that any interest or profit taken by the capitalist is necessarily a form of robbery. It is not a question of degree—that the capitalist has taken more than he is entitled to—but that the capitalist is not entitled to take anything at all, and that anything he takes is essentially a theft.

*Labour's Capacity.*—For this contention it is very difficult to find any real ground either in fact or in theory. Labour, in the sense of manual labour, by itself can effect nothing. Put down the most skillful hand-worker on a bare piece of ground and he cannot produce anything out of it until he has made himself tools and so become a capitalist; and, in the meantime, he would somehow have to feed himself on any roots that he could dig up, or any wild animals that he might be able to kill. Even if we include under labour the brain-workers and organizers, it remains true that any body of skilled workers, organized as well as possible under the most skillful management, would be equally ineffective without the assistance of the factory, tools, and other equipment which have to be supplied out of capital, that is to say out of the accumulation of past savings, before they can produce effectively. Labour by itself can effect nothing industrially or commercially; labour plus management is equally powerless. Capital by itself is, of course, in exactly the same position. Anyone who through the possession of capital owns a large supply of raw materials, and the necessary land, factory and equipment, can make nothing out of them without efficient management and efficient manual labour. These truisms are usually acknowledged by the extremist advocates of labour's claim to what is called the whole of its product. They admit that labour must have machinery and tools to work with; but Mr. Philip Snowden, for instance, the English Labour M.P., has contended that "the existence of a rich class who do no labour is the conclusive proof of the claim that labour does not receive all that labour creates, but that a surplus over and above the wages of labour is appropriated in some way and some form by those who do no work." But this argument begs the whole question by assuming that "labour creates" all that labour produces with the help of machinery. It seems to be based on a confusion of mind which imagines that because the machinery and equipment by themselves can produce nothing, therefore, those who work them and make them efficient are entitled to everything that is produced by their own efforts assisted by the machinery. In fact the existence of the machinery, which has been provided by the possibly idle capitalist, enables the manual workers to produce goods of an immeasurably greater volume and value than they could turn out without it. If labour is entitled to the whole of its product, as it surely is, it is also true that labour gets the whole of its product and a very great deal more, because, owing to the assistance given it by the machinery and equipment provided by capital, it is able to produce a very much greater volume of goods, and the bargain between it and capital results in its being better off than it could have been without capitalism's assistance.

To take an obvious example, let us suppose a man in a primitive stage of society to have hit on the idea of making a spade, and so greatly increasing his own production of food. If he then makes a second spade and lends it to a friend, enabling the latter to multiply his production and charging him a portion of the increased food for the use of the spade, then we see a rough analogy of the bargain which under capitalism is struck between capital and labour. In this case the friend who borrows the spade works for the capitalist who lent it, but he also works for himself. By the use of the spade his production is multiplied manifold; and to argue that he is entitled to take the whole amount of what he produces with the assistance of the spade, and that the

man who invented and lent him the spade robs him by taking part of the increased production which it brings into being, is surely an example of astonishingly distorted logic. At the same time it has to be remembered that those who claim the whole product of industry for the manual workers can say that all the factories, means of transport, tools and machinery have actually been erected or produced by manual labour. But this manual labour, and the skill which organized it, were paid to produce these instruments by owners of wealth who were prepared to risk it on these objects. All these forms of the equipment of industry only came into being and increased the numbers and welfare of the whole community because some of those who controlled wealth when they were first invented used it to secure their manufacture and production instead of upon their own immediate enjoyment. At any time the future development of any country or community depends upon the extent to which its members are prepared to postpone immediate enjoyment to the provision of equipment for its further progress. If some of our ancestors had not made investments in industry in the past, and so equipped the world with all the machinery of industry and commerce, probably not half of us would now have been alive. Interest and profit are thus the reward paid for successful investment in the means of life in the results of which we all share.

*Means of Production.*—Critics of the capitalistic system are, at first sight, on firmer ground when they argue that it is wrong that anybody should possess, by the ownership of private wealth, this responsibility for the future development of the country or community; that injustice arises because private ownership makes it difficult and sometimes impossible for those who want to work to secure access to the means of production, and that a more equitable basis would be arrived at if all the means of production were owned by the state, or by some other public body, or, as is now contended by the syndicalists and guild-socialists, by the industries which employ them organized into an all-embracing trade union or guild.

There can be no question that the existence of private property in the means of production does involve hardships and difficulties for those members of the community who do not happen to be born into the possession of property, or of the kind of qualities, which enable them to acquire it rapidly. To such people, the ordinary unskilled workers, it must naturally seem unjust that if the kind and quantity of work that they offer to any private employer is not needed, some of them find great difficulty in earning a livelihood for themselves and their dependants. And the question that we have to consider is whether the hardships involved to a comparatively small number of the less fortunate members of the community are balanced by the advantages to the community as a whole involved by the working of the capitalistic system. Under that system anybody who by ingenuity and energy can earn more than his fellows is enabled and encouraged to do so and to devote his accumulations to the furtherance of industry by putting them out at interest, or engaging them in enterprises from which he hopes for profit. There is consequently a continued stimulus for activity and exertion, and it must always be remembered that this activity and exertion can only be successful if it produces something with which the community, as a whole, or a sufficient number of its members who are in a position to buy goods and services, are satisfied.

Thus, by this stimulus, the wants of the community have been continually considered and cared for by its most enterprising members, who are urged to do so by the hope of gaining profit. If this stimulus were taken away it is at least possible that progress would be very greatly retarded and that the interests of the community, as a whole, especially those of its poorest members, would be seriously affected. It has to be admitted that the wants of the community are not always wholly sensible and are very often marked by highly questionable taste. These drawbacks are surely to be best amended by the education of the community to a more sensible and tasteful use of the power that it has by its decision, through the manner in which it spends its money, concerning the goods and services which are turned out by industry. If the decision as to what is to be produced is to be

in the hands of a bureaucratic committee, as under state socialism, or of a guild or trade union committee, as it would apparently be under guild socialism or syndicalism, then it is perhaps possible, though highly doubtful, that the objects on which the productive enterprise of the community would be exercised might be more sensible and tasteful; but the general members of the community, having no power of choice, would not be exercising sense or good taste, but would merely be taking, whether they liked them or no, goods and services provided by the decision of an outside body.

*Advances under Capitalism.*—A more serious doubt arises whether under any alternative system that has yet been suggested the actual needs and necessities of the community would be successfully met. We have to admit that under capitalism there has existed and still exists a great deal of destitution and poverty which are serious blotches on the success of the system. On the other hand, anybody who takes even a superficial and cursory view of the productive progress of the last century and a half under modern capitalism must admit that an enormous advance has been secured. There is no need here to enumerate all the miraculous inventions by which man's power over nature has been increased, and his productive capacity has been enormously multiplied. The extent of these powers was only fully realized when the World War came, and, in spite of the view expressed by some economists that a modern continental war could not last more than a few months because the economic strain would be too great, it was nevertheless possible to carry the war on for more than four years, to develop the production of lethal weapons during its course on a scale which has never heretofore been dreamt of, to feed and clothe the armies in the field much better than armies in the field had been fed and clothed before, and, at the same time, at least in England, to increase the standard of comfort of the greater part of the population. These achievements were in fact only carried out by making drafts to some extent upon the capital resources of the countries engaged, as, for example, when England sold back to the United States her investments in American railway bonds in exchange for food and munitions of war, which she was importing from America. But, when full allowance has been made on this score, the fact remains that the World War demonstrated a growth of productive capacity which had not been suspected until the supreme test aroused the energies of all the chief nations of the world.

But, apart from this astonishing effort at a time of crisis, we may take the prosaic facts of the last half of the 19th century as quoted by acknowledged champions of socialism. Mr. Sidney Webb, in his *Industrial Democracy*, speaks of "the past fifty years' rise in the condition of the English wage-earning class." Mr. Snowden, in his *Socialism and Syndicalism*, says that according to official figures between 1850 and 1900 the wages of the working classes in England had risen by 78%, and at the same time there had been a fall in the prices of wholesale commodities of 21%. This is surely a wonderful achievement which has to be granted as practical evidence of the efficiency of the capitalistic system, and of the extent to which its benefits were being shared with those who did its manual labour.

Mr. Snowden objected that the prices of wholesale commodities are not the best possible test of the buying power of the wage-earners, and that certain articles which they use had in fact risen. This may be so, but nevertheless the very great advance in actual money wages, accompanied by a quite appreciable reduction in the prices of many articles of general consumption, is a stubborn fact. This, indeed, Mr. Snowden to some extent admits, but he goes on to argue that this progress had stopped at the beginning of the 20th century, and that the tendency had then become permanent by which the share of the wage-earners in the product of industry was actually going backwards. This was certainly true in the first few years of the century, since the rise in wages, which still continued, did not quite keep pace with the rise in general prices. But Mr. Snowden's contention that this tendency was permanent was merely an assumption which might easily have been proved false even if the war had not happened. As we all remember, the World War came at a time when

the manual workers of England were preparing a great attempt to improve their position, and there is every reason to assume that this attempt would have been successful. In any case, the war came and the general position of labour was certainly improved during its course. Since the war, the struggle between wages and prices to keep up with one another has been somewhat difficult, but it may at least be contended that this has been due not to an essential fault in capitalism, but because the wage-earners thought fit to restrict output in a mistaken belief that they would thereby resist any attempt to force them back to the pre-war standard, which they were rightly determined to avoid.

We have also to remember that under the sway of capitalism this very considerable improvement in the wage-earners' lot has been carried out in spite of an enormous increase in population. If it be admitted that the general standard of life before the World War was not all that it should be, it must also be admitted that the gift of life and all that life involves had been showered upon millions of people in all the economically civilized countries of the world, who could not have come into being if it had not been for the great increase of wealth under capitalism.

*Weakness of the Alternatives.*—One of the strongest arguments in favour of the present capitalistic system is the weakness shown by any system with which its critics would propose to replace it. State socialism has long been before the public as an alternative to the private ownership of capital. If it could be worked its economic advantages would be considerable, because it would mean that the state would own all the means of production and so would be the sole purchaser and the sole organizer and the sole distributor. The state would, therefore, decide what the needs of the community were, and how much work had to be done to provide them, and would set the members of the community to work to provide these things. All the waste involved by competition and advertisement would be saved, and all the mistakes in production would be avoided, which now arise because those who organize production have to try to foresee and forestall the needs of the public. The state would say what work each one of us was to do and what goods each one of us was to consume. If it were really possible that under this system we should work as well as we work now, there can be no doubt that the business of supplying the community's needs, as interpreted by the state, would be free from many of the joltings and jarrings which now often put the industrial machinery to some extent out of gear. But, in the first place, there is the enormously important question whether such a system could work at all—whether in fact the ordinary human being, as he is to-day, would be prepared to work at the bidding of the state, on conditions laid down by the state, with anything like the enthusiasm and readiness with which people work nowadays with the prospect of securing profit and advantage to themselves. Even if it be true that the great majority of commonplace people, who do not at present work with much enthusiasm or energy because they know that their own chance of achieving striking success is remote, would work for the state as well (or as indifferently) as they work now for private employers, there is very considerable doubt whether the more stirring spirits who think they can see their way to fortune in present circumstances if they work for it with determination, would put anything like the same vigour into work that they did for the state; it is upon the energy and readiness to take risks of this comparatively small body of stirring spirits in the community that economic progress really depends. If we stifle the incentives which now spur them to take risks and try experiments in the hope of fresh opportunities of profit, there is grave danger not only that the economic progress of the community might be checked, but that its whole economic organization might fall into decay and slothfulness, and that any attempt to improve or expand might be met with the same cold and unresponsive stare that now usually greets any new suggestion that comes up before officials of government departments. It might be possible in time to produce a set of officials who would be as ready and eager to promote the economic efficiency of the community as are the present captains of industry stirred by the incentive of profit. But past experience does not show that there

is much hope of this happening, at any rate for many years, and in the meantime any community which subjected itself to state socialism might find itself very much worse off. It is true that during the World War great feats were achieved by government departments in organizing the supply of food and of war munitions, but they were achieved because the spirit of the nation was stirred to meet the most momentous crisis in its history; and because government departments were able to rely upon the assistance and experience of a large number of men who came to work in them, who had been trained in the school of practical business based on the incentive of private profit. And even so, these official achievements during the war were only carried out at a cost which the country could not possibly have stood except for a comparatively short time; they also involved continual friction between government departments and the wage-earners whom they employed, and their general results were so unsatisfactory that it is now a commonplace, even among labour leaders who are most anxious to nationalize industry, that whatever happens "bureaucratic control" must not be allowed to take charge. "Government departments are in the worst of bad odours just now, and nothing which seemed to involve an extension of bureaucracy would have a chance at the polls"—so writes Mr. Gerald Gould, one of the latest exponents of socialist ambitions, in *The Coming Revolution in Great Britain*, published in 1920. How it is possible to organize nationalized industry without bureaucratic control has not yet been shown.

*Nationalization.*—The nearest attempt at solving this problem is made by the syndicalists and guild socialists, who do so by giving the nation remarkably little to say in the conduct of industry. Syndicalism in fact seems, as far as one can make out from the shadowy sketches that are obtainable of the desires of its champions, to ignore the state altogether. It proposes that the workers in any industry should seize the industry's capital equipment for themselves and work it for themselves. It is difficult to see how such a scheme could possibly be worked in practice. With each industry its own master there does not seem to be any means of arriving at any common denominator for the exchange of their products, that is to say, of arriving at a price, and the question of the provision of further capital seems to have been left out altogether. Guild socialism seems to be an attempt to reconcile syndicalism and state socialism and to arrive at a working compromise by a compound of the two. Unfortunately, its schemes as at present expounded seem rather more likely to suffer from a mixture of the drawbacks of both systems. The guild socialists consider that the capital equipment of industry should be owned by the state, but that the whole organization of industry, the decision as to what is to be produced, and the control of the product, are to be in the hands of those who work in it with brain or with hand. Here again we have the difficulty as to how we are to arrive at a means of exchange between one guild and another. If the shirt-making guild thinks that its members ought to get a pair of boots in exchange for two shirts, while the boot-making industry thinks that a pair of boots ought to be exchanged for three shirts, who is to decide between them and what power is to enforce decision? In the exceedingly vague sketches of the guild systems that have been produced by their champions, some attempts have been made to answer these questions. It is suggested that there would have to be a guild parliament representing all the guilds, a state parliament representing the consumers, and apparently yet another parliament which is to settle matters when these two parliaments cannot agree. Obviously there are materials here for economic chaos. It is true that if everybody worked with a perfectly angelic spirit such a system might possibly be able to carry on the work of production, but if everybody had an angelic spirit: any system, even capitalism, would also be highly successful. But the guild socialists have to admit that, if any particular guild which was strong enough chose to hold a pistol at the head of the rest of the community by refusing to work except on its own terms, serious difficulty would arise. In fact, some of its more candid advocates have stated frankly that the wage-earners might conceivably be a good deal worse off under guild socialism; but they seem to

think that a diminution in their actual control of goods and comforts would be more than compensated by the greater freedom they would enjoy, and by the feeling that they were no longer working to profit a private capitalist.

*Economic Tyranny.*—How much truth is there in this claim for the greater freedom to be enjoyed by the wage-earners under guild socialism? One of the principles on which its champions most strongly insist is that production and the control of the product are to be in the hands of the guildsmen themselves, and that, consequently, they will be able to insist on producing goods which they think should be produced, rather than goods which consumers would prefer to consume. One of their champions, Mr. G. D. H. Cole, even goes so far as to mention the right to "choose whether they will make well or ill" as one of the things which must be secured for the workers under guild socialism. Certainly the right to work well or ill is a very large extension of freedom of a kind, but is it likely to react in favour of freedom in the fullest sense of the word? As industry is now organized under the principle of the division of labour, every one of us produces or helps to produce one article or fraction of one article, but we consume hundreds of articles. Economic freedom, that is to say, freedom to provide ourselves with such goods as we should like to consume, thus seems to be much more real under capitalism, which gives us the right to spend our wages and salaries as we please, than it would be under state socialism or guild socialism. State socialism would tell us what work to do and what goods to consume; and guild socialism, though apparently leaving to us, when once members of a guild, the right to decide along with our fellows concerning the goods that we will produce, and also as to whether we will work well or ill, would nevertheless leave us dependent upon the decisions of the other guilds as to what kind of goods they chose to produce, and upon the inclination to work well or to meet our demands with shoddy and ill-made commodities. Since this is the kind of freedom which is held out to the wage-earners under these rival systems, there certainly seems to be good reason why they should think many times before taking a leap in the dark by adopting them.

*Capitalism and Progress.*—Such are the doubts and difficulties that face us when we contemplate the practical working of any alternative so far suggested to capitalism. For it, on the other hand, we can at least claim that, with all its faults, it has achieved a marvellous improvement in the command of man over natural forces; and has produced an enormously greater amount of wealth, which has been distributed, though in a manner which leaves a good deal to be desired, over a greatly increased population. Along with this purely material improvement there has proceeded a great expansion in education, sanitation and social reform. Capitalism can certainly lay no direct claim to the whole of this expansion, a great deal of which has been brought about, in spite of the opposition of the propertied classes, by a few enthusiasts, educational and scientific; but capitalism can fairly claim that these enthusiasts could not have done their work if there had not been available the surplus supply of wealth which was called into being by the efforts of private enterprise working with the incentive of profit. A noted labour leader has recently said that capitalism has made England a "C. S." nation. But this description is more rhetorical than accurate. England's achievements by land and sea, during the World War, and likewise those of her Allies and enemies, who had also developed their resources under a capitalistic system, were such as to astonish those who had anticipated that the drift of the populations into great towns, and their occupation under sedentary conditions, would make it difficult to find armies who could fight with the spirit in which armies fought in former days. In fact, armies were produced in proportion to the population on a scale previously undreamt of, and fought an almost continuous battle for four years, showing unprecedented courage under conditions that no armies had hitherto been asked to face. The spirit and physical power of the countries which have grown into material greatness under the capitalistic system certainly show no sign of demoralization. At the same time it is true, as has already been admitted, that the blot of destitution is one which has to be

cast from the record of capitalism before it can claim to have produced a system which is really worthy of what is called civilization. If capitalism is to continue it will clearly have to remedy this evil and others which have already been mentioned. The leading spirits among those who are interested in its maintenance are fully aware that these things have to be remedied. In fact the change of attitude on this point among employers in recent years almost amounts to a revolution, though there are still too many obstructive exceptions. Associations formed for the face-to-face discussion of these points by employers and employed are already common, and, on the side of the employers, it is certainly true that (perhaps under the spur of self-interest) they are earnestly trying to repair the weaknesses in the system which they have to work. Their difficulty is to know what it is that labour really wants; what concessions can be made which will induce labour to work the capitalistic system with hearty co-operation. Improved conditions, higher wages, and greater influence on problems of management, the best of them are more than ready to grant if only they can secure in return for their active working during the time when the manual labourers are engaged on their job, and the renunciation of the policy of the restriction of output. It would appear from the utterances of those who consider themselves entitled to speak for labour, such as Mr. Sidney Webb and Mr. Cole in England, that labour has made up its mind that it is not going to work in future to put profits into the pockets of private employers; in other words, it is determined to end the capitalistic system. Whether the rank and file of manual workers have really adopted this extreme view may very well be doubted, but they are extremely likely to adopt it unless they can be granted greater security. This is certainly a demand on the part of the manual worker which will have to be met by capitalism if it is to survive. The anxieties of the ordinary manual worker, who does not know how soon he may be told that he is no longer wanted at his job, should always be present in the minds of the employers, and if the schemes now being mooted by which every industry should make itself responsible for its own unemployed can be brought into practical effect, there can be no doubt that one of the worst evils of capitalism will have been abolished.

Another reform on which the manual workers seem likely to insist is a clearer statement of the costs and profits of industry. At present the accounts published by joint stock companies usually only succeed in making darkness visible. Labour has so often been misled as to the capacity of industry to stand concessions to it, that employers will be well advised to produce a more scientific system of accounting, by which they can be able to prove to demonstration what the true costs of industry really are, how much is required for depreciation and upkeep, how much goes to labour and management and how much is taken by capital.

As to the sordid ugliness with which capitalism is usually charged, everyone who has visited an English north-country industrial town must admit that the system in its craving for cheap production has ignored many things which make life tolerable for those who work for it, and has therein shown only another example of short-sightedness for which it now has to pay. Even on this point, however, one feels a certain doubt whether any alternative scheme of state socialism or guild socialism would provide the community with the necessary leisure and surplus wealth that could be devoted to the beautification of the country which adopted it, as is too usually assumed. If everybody is to have a nice house and live in pleasant surroundings, production has to be organized so as to be not only comfortable for those who are engaged in it, but efficient in the matter of output. And, on this subject, as has already been shown, there is good reason to doubt the efficiency of alternative schemes.

*Inherited Wealth.*—Another of the weaknesses of the capitalistic system is the power that it gives to owners of wealth to continue to accumulate it and pass it on to their heirs and assigns, with the result that a class is created which is able to live in great luxury on the past efforts of their ancestors, relatives, or friends, without making any effort to justify their own existence. These

could be no doubt that the existence of these huge fortunes, accumulating and being passed on, are a source of great bitterness among the classes which do not possess them. Much might be done to alleviate this bitterness if all the owners of this wealth, and not only a certain number of them, were careful to make a more public-spirited use of it. It is true that they owe it to the work and exertions of others who have passed on this wealth to them, but this is only partially so. A large part of it they really owe to the existence of an ordered society providing a market and outlet for the efforts of those who accumulate the wealth and a machinery for investing it and re-investing it, and so increasing it from generation to generation. From this point of view a large part of their great wealth they owe to the community in which they live, and the assumption that it is their own to do what they like with is a dangerous one which will cost them dear if put into practice too logically. It is possible, however, that this evil may be cured, at least to a great extent, by the development of death duties and inheritance taxes, which seems likely to be an increasingly important part of the fiscal arrangements of civilized nations in time to come. Here again, however, there is danger that if this remedy is exercised too freely the process of accumulation which is required to provide the community with capital for fresh enterprise may be dangerously checked. For the evil of huge fortunes is balanced by the fact that it is largely from them that accumulations of new capital on a great scale are effected; and it is highly dangerous to diminish them by the use of the fiscal weapon, before the duty of saving and accumulating has been effectually brought home to those classes of the community which are now accustomed to spend all that they earn or receive.

*Need of Extended Capitalism by Savings.*—The efforts made in England and America and elsewhere, during the war, to try to induce everybody to save for victory have had effects which astonished those who were most closely acquainted with the thriftlessness of ordinary human nature (see SAVINGS MOVEMENT). Long before then the cooperative movement had already developed a new and very interesting form of capitalism among the wage-earning classes. Cooperation is sometimes described by its own champions as an effort directed to the overthrow of private capitalism, but it is in fact merely a variation of it. Cooperation assembles the shillings and pounds of the wage-earners and puts them into productive and distributive industry, especially the latter, with marked success. The division of the profits is effected on different lines, those of the retail shops being divided among the purchasers in accordance with the amount of their purchases. So far its successes have been won on a somewhat narrow field, but there is no reason why they should not go ahead at a greatly accelerated pace as the higher earnings of the workers give them a larger margin available for saving. If this tendency could be continued,—if good work, rapid production, and high wages could be accompanied by individually small accumulations of capital by the great mass of the wage-earners, and if they could thus be induced to become not only wage-earners but themselves also capitalists, and if, at the same time, the large capitalists could be induced to see that the use they make of their incomes and of their leisure is a matter which concerns the community as well as themselves,—then it might be possible to arrive at a state of affairs in which every worker was a capitalist and every capitalist a worker, and capitalism, shorn of many of its worst evils, might work miracles of industrial production.

*Authorities.*—Gustav Cassel, *The Nature and Necessity of Interest* (1906); Prof. Shield Nicholson, *The Revival of Marxism* (1920); Philip Snowden, *Socialism and Syndicalism* (1913); J. Ramsay Macdonald, *The Socialist Movement* (1911); G. D. H. Cole, *Self-Government in Industry* (1917); Reckitt and Bechhofer, *The Meaning of National Guilds* (1918, 2nd ed. 1920); Harold Cox, *Economic Liberty* (1920); H. Withers, *The Case for Capitalism* (1920); Gerald Gould, *The Coming Revolution in Great Britain* (1920); Hugh Dalton, *The Inequality of Incomes* (1920); J. G. Brooks, *Labor's Challenge to the Social Order* (1920). (H. W.)

CAPORETTO, BATTLE OF.—The Italian offensive<sup>1</sup> of Aug.—Sept. 1917 had reduced Boroëvic's armies to the limit of resist-

<sup>1</sup> See generally under ITALIAN CAMPAIGN.



ance, so much so that, as Ludendorff records, "the responsible military and political authorities of the Dual Monarchy were convinced that they would not be able to stand a continuation of the battle and a twelfth attack on the Isonzo. . . . In the middle of Sept. it became necessary to decide for the attack on Italy in order to prevent the collapse of Austria-Hungary."

Though the Italian advance on the Bainsizza plateau had come so near to a definite break through, it had left the Italian II. Army badly placed for defence. South of Tolmino the Aust. fighting had bitten out a wide salient on the Bainsizza plateau. North of Tolmino the Italians were still in the positions they had occupied early in the campaign, among the mountains on the left bank of the Isonzo, with comparatively little room between the trenches and the river. Neither sector of the line was satisfactory for defence, and on the Bainsizza there had been little time to make adequate preparations, because of the rocky nature of the ground. But the real weakness of the situation was due to the enemy's possession of the Tolmino bridgehead. The bridgehead itself was strong, as it did not form a salient, the Austrian line running nearly due N. and S. from the great ridge of Rudenci Rob (6,250 ft.) by Mrzli and Vodil Vrh to the high hills of the Lom plateau, N. of the Bainsizza. The bridgehead was well protected by these flanking bastions, and for this reason it made an excellent point of departure for an attack. The ridges in front of it rose steeply, and were strongly held by the Italians, whose position, however, suffered from two grave drawbacks. In the first place it was impossible to support the defence by direct flanking fire against attacking troops; in the second place, there was little depth in the lines traced on the Zagradan-Jeza ridge, which fell rapidly to the head of the Judrlo valley and the glens which carry the minor streams between the Judrlo and the Natisono.

There was a clear difference of opinion on the Italian side as to the best way of meeting the forthcoming attack. Cadorna was convinced that he had to stand on the defensive, the more so as he was uncertain in which sector of the Julian front the chief blow would fall, but his instructions naturally included and recommended vigorous local counter-attacks. Capello, who commanded the II. Army, did not like the idea of the defensive. His army was in the main aligned for attack. Preparations had been made for a continuation of the offensive which had been broken off in Sept., and it was not possible, given the difficulty of communications and the risk of imminent attack, to take up those positions best adapted for defence. He felt, in addition, that opposite the Tolmino bridgehead he had little room for defence, and he was anxious to anticipate the enemy's move by an attack N.E. from his positions on the Bainsizza plateau. In this idea he had the support of more than one of his corps commanders, but Cadorna thought, and it is difficult to meet his reasoning, that he could not throw in the forces necessary for such an attack when he was uncertain as to the direction of the forthcoming blow. His first news from the enemy side spoke of an attack against his new lines on the Bainsizza. Later came the report of a more general attack, "from Plezzo to the sea." The enemy believed that Cadorna had been deceived by demonstrations made in the Trentino, and their belief was fortified by news that he was sending guns westward. But these were the French and British heavy guns (nearly 200 in number), which had been withdrawn when he stated that he could not renew his offensive, and a number of batteries now restored to the Trentino front, which had been stripped for the earlier fighting.

Cadorna was still preoccupied about the *moral* of his troops, and he made careful inquiries on this point, which received very satisfactory replies. He was especially anxious as the units which had suffered heavily during the last offensive were but newly filled with fresh drafts, and he had found reason before to fear the influence of some of the men fresh from the depots. But the answers of his corps commanders were thoroughly reassuring. He had enough men, though a number of his units were below strength, while others were battle-worn and others again had suffered much from an intestinal disease that had

been prevalent in the valleys of the Natisono and the Judrlo; and he had enough guns, in spite of the withdrawal of the Allied artillery, though he would doubtless have been glad of a larger reserve. Between Monte Rombon and Monte San Gabriele, Capello had some 2,200 guns and nearly 800 trench mortars.

North of Tolmino the line on the left bank of the Isonzo was held by Cavaciocchi's IV. Corps, whose left wing held the Plezzo basin and was in contact with the Carnia Force on Monte Rombon. Next came Badoglio's XXVII. Corps, whose left wing, the 19th Div., raised to the strength of an army corps, held the lines opposite Tolmino. The other three divisions which completed the XXVII. Corps were across the river S. of the Lom plateau. Behind the 46th and 19th Divs., on the mountains W. of the Isonzo, lay the VII. Corps, newly reconstituted with units from other corps, and commanded by Gen. Buongiovanni. On the right of the XXVII., holding the line as far as the Sella di Dol between Monté Santo and Monte San Gabriele, were Cavaglia's XXIV. Corps and Albricci's II. Corps, each of three divisions, with the XIV. Corps in immediate reserve. The Gorizia sector, from Monte Santo to the Vipacco, was occupied by the VI. Corps (Gatti) and the VIII. (Grazioli). South of the Vipacco the Duke of Aosta's III. Army had three corps (seven divisions) in line—XI., XIII., and XXIII.

The weak point of the Italian line was the Tolmino sector; the weakest part of this sector was at the junction of the XXVII. Corps (19th Div.) with the IV. (46th Div.), and the weakest position of all was that held by the right of the 46th Div., who were clinging to the slopes of Mrzli Vrh, completely dominated by the enemy, and badly off for communications with their neighbours. The Tolmino sector was chosen for the main enemy attack, and here, owing to a complex of circumstances, the Austro-German forces won a success that led to a great Italian disaster. In anticipation of the main drive in this direction, the II. Army reserves (XXVIII. Corps and various other units) were lying N. of Cormons, while three divisions under the direct control of Cadorna waited between Cormons and Clivdale, at the foot of the valleys that run down S.W. from the threatened point. A further general reserve consisting of the XXV. (four divisions) and XXX. Corps (two divisions) lay about Palmanova, ready to be sent N. or E., according as the fighting developed.

The Italian preparations were much handicapped by the illness of Capello. From the beginning of Oct. the commander of the II. Army was seriously unwell, and though he had the assistance of Gen. Montuori, who was brought to Army Headquarters from the II. Corps, the II. Army undoubtedly suffered much from Capello's physical unfitness. Montuori had only taken command of the II. Corps a few weeks before; he had come from the Asiago uplands and knew little or nothing of the II. Army front. On Oct. 20 Capello left for Padua, in the hope of securing a short rest, leaving Montuori in command. His rest lasted less than two days; for when the imminence of the enemy attack was confirmed by two deserting enemy officers, of Rumanian nationality, he returned to resume his command, reaching Cormons late on the night of Oct. 22.

The main attack came in the direction anticipated, between Monte Rombon and S. of Tolmino, and was conducted by a mixed German and Austrian army under Gen. Otto von Below. The army, which was known as the XIV. Army, consisted of nine Austrian divisions and seven German, divided into four "groups." The northern group of four divisions (three Austrian and one German Jäger) was commanded by Krauss, who had been called back from the Bukovina. Next came a group of three divisions (one Austrian and two German) under the German von Stein, and a group of two German divisions under the German von Berrer. South of these two central groups was a mixed group under the Austrian von Scotti (commander of the Austrian XV. Corps). This group consisted of one German and two Austrian divisions. Behind these, E. of Tolmino, lay four divisions in reserve, at Below's immediate disposal. Borojevič had 20 divisions in his two "Isonzo" Armies between Auzza and the sea. Below and Henriques (II. Isonzo Army) had some 2,500 guns and 500 trench mortars.

The bombardment began at two o'clock on the morning of Oct. 24, in wild autumn weather. There was a drizzle of snow on the high ridges, rain below, and mist everywhere. The bombardment opened with a shower of gas shells, mainly directed against the artillery positions. It was only later that a very heavy fire was opened on the trench lines and upon all the zone to the rear of them. Towards dawn the fire died down, and it was thought on some parts of the defending front that the bad weather had counselled a delay in the attack. The wind had risen, the rain was blown in sheets, and the snow was whirling thickly on the mountains. But the attackers were to make skilful use of the weather conditions. Only on Monte Rombon, on Krauss's extreme right, an attack in conjunction with the left wing of Krobatin's X. Army had to be given up owing to the snow.

Krauss's main attack was a straight drive through the Italian lines in the Plezzo basin, his first objective the Saga defile. But he calculated that this position, too, must be carried in the first rush, so that he could reach without delay the great ridge of the Stol (6,467 ft.), which stood athwart a further direct advance. For this attack he detailed the 22nd Schützen Div., followed immediately by a Kaiserjäger and a Kaiser-schützen batt., which were to go straight for the Stol, and by six battalions of the 3rd (Edelweiss) Div., which were to make for the Val Fella by way of the Val d'Uccosa. Krauss's left-hand division, the 55th (Bosnian), attacked the Vrsich-Vrata ridge, with the object of breaking through to the Isonzo and Caporetto.

Krauss's main drive, after hard fighting, broke through the three lines held by the 50th Italian Div. in the Plezzo basin, but the attacking troops were checked at the Saga defile, where the Isonzo turns at right angles round the end of the Polounik ridge. When evening fell the position was still in the hands of the Italians, but the battle had gone badly for the defenders further south, and a retreat to the Stol became necessary. Krauss's Bosnians had met with no success against the left wing of the Italian 43rd Div., being driven back by counter-attacks after capturing the front lines, but Stein's group had carried all before it. Stein opened his attack with his right wing, the Austrian 50th Div., at 7:30 A.M., attacking the Italian 46th between Monte Nero and Vodil Vrh. A little later the Bavarian Alpenkorps, advancing from Tolmino, attacked the ridges below the Passo di Zagradan, while Berrer and Scotti attacked farther south. When both Stein's initial attacks were under way, the 12th Silesian Div., under the command of Gen. von Lequis, was sent in between them. Lequis attacked in two columns, one on each side of the river, with instructions to drive straight for Caporetto, where, it was hoped, he would join with Krauss's Bosnians. Both columns were completely successful. The right-hand column, aided by the strong attacks of the Austrian 50th Div., pierced the extreme right of the Italian 46th on the E. bank of the river and pushed N.W. with all speed. On the opposite bank the attack was equally successful. The Alpenkorps were making good headway on the slopes above the road, where the Tarò brigade, surprised in the mist, made a feeble resistance, and Lequis's left-hand column quickly reached the Italian second line, where the valley narrows below the hamlet of Fonè. This line, running up to Monte Plezia, had been held, until the eve of the battle, by a Bersaglieri brigade which formed the extreme right wing of the IV. Corps, but at the last moment this sector was transferred to the command of the XXVII. Corps, the Bersaglieri were given to Cavaciocchi as an additional reserve, and Badoglio received the Napoli brigade for the purpose of holding this important point. Only one battalion, however, was placed on Monte Plezia; the rest of this regiment (the 76th) lay at Passo di Zagradan, high upon the ridge to the west, and the other regiment of the brigade (the 75th), together with the brigade command, was nearly three m. away, on the western slopes below Zagradan. The single battalion, of which only a platoon was down by the river, seems to have been taken completely by surprise. It was run over by the German attack, and the Silesians proceeded on their way up the valley practically unnoticed. The rest of the regiment had seen and heard nothing

in the mist (they were being heavily shelled), and the VII. Corps, of which the 3rd Div. was waiting on the Kolovrat ridge, appears to have been equally unconscious of the course of the battle.

Meanwhile the Alpenkorps, Berrer's two divisions, and Scotti's right wing were breaking up Badoglio's left, while the latter's right, across the river, and Cavaglia's XXIV. Corps were being strongly attacked by Scotti's left and the right wing of Henriquez's II. Isonzo Army. The attack from Tolmino was carried out with skill, speed and resolution, and by a capital error which has never been satisfactorily explained the Italian guns remained silent until too late. Definite orders had been given both by Cadorna and by Capello that immediately upon the opening of the enemy's bombardment the Italian artillery should reply with a fire of "counter-preparation" upon the enemy's trenches and zones of concentration, and that they should lay down a violent barrage as soon as there were signs of movement. This order was not carried out as intended. The guns of the IV. and XXVII. Corps, and particularly those backing the 19th Div., were apparently ordered to hold their fire till the word of command came from Corps headquarters. The word did not come to the batteries until too late, some never received it at all. The heavy mist, and the fact that the weight of the enemy bombardment had worked great destruction among the telephone wires, combined to prevent any effective reply on the part of the Italian guns. When the guns began, their fire was fitful, uncertain, blind, and they were too late. The enemy's attack had already developed when the Italian guns opened on his trenches. Taken by surprise, puzzled by the comparative silence of their own guns and blinded by the mist, the troops of the 19th Div. opposed only a weak resistance to the Austro-German attack. They were heavily outnumbered, but they held strong positions which should have enabled them to delay the enemy advance until the reserves could come into play. Some of the troops fought with all their old stubbornness; but others gave themselves up or abandoned the trenches when the enemy columns came out of the mist.

Henriquez's attack on the Bainsizza plateau, although it met with some initial success, was readily repulsed, and Badoglio's troops captured several hundred prisoners in a strong counter-attack. Badoglio had hoped to hold the enemy attack from Tolmino, and turn the scale by a counter-attack on the Lora plateau with his three divisions on the left bank of the river. He seems to have had the idea of doing on a smaller scale what Capello had wished to do in large, and it certainly appears as though he had kept his left unduly weak in the hope of being able to deal a heavy counter-blow. If he had obeyed in the letter Cadorna's order that the greater part of the forces belonging to the XXVII. Corps should be brought back to the right bank of the Isonzo (the 19th Div. and its reserves counted five battalions more than the three divisions across the river), it can hardly be said that the spirit of the order was carried out. In any case, Badoglio was not afforded the chance of attempting any such manoeuvre as he may have had in mind. It was long before he received any news of how the day was going on the front of the 19th Div., and from the beginning of the action he was unable to communicate with his divisions on the left bank of the river. Telephones had broken down; the mist prevented signalling, and despatch riders do not seem to have been employed. It was not until the afternoon that Badoglio heard that his front lines were gone and his main positions threatened. He knew nothing of the break through in the valley and had no news from the IV. Corps. In a message sent to Army Headquarters at 4 P.M., he reported the enemy success south of Jeza, but said that he had no news from the commands of the 19th Div. and the troops farther N., and that he was unable to communicate with anyone.

By 4 P.M. Lequis's Silesians were approaching Caporetto. The left-hand column was unmolested by the troops of Buongiovanni's VII. Corps, which were lying too far back and were very slow in coming on the scene. The right-hand column, which had cut in behind the Italian 43rd Div., was making the task of the Austrian 50th comparatively easy, and brushing

side the spasmodic opposition of such small detachments as came in its way. The Austro-German advance was facilitated by the fact that Cavaciocchi had filled his front lines too full, and sent all his reserves across the river, in immediate support of the 43rd and 46th Divisions. When Lequis was approaching Caporetto Cavaciocchi had nothing in hand but a squadron of cavalry and one battalion of infantry which had not yet reached its destination E. of the river. For some hours previously Cavaciocchi had been calling on the VII. Corps, but Buongiovanni was very slow, not without excuse. His Corps was a scratch formation; his original left-hand division had been broken up two days before to strengthen the IV. and XXVII. Corps, and the 62nd, which had been assigned to him in its stead, was only moving up to take its place N. of the 3rd, already aligned, but too far back, on the ridge running N.W. from the Passo di Zagradan. A further difficulty was that no definite plan of action had been agreed on between Cavaciocchi, Buongiovanni and Badoglio, whose close co-operation was clearly necessary. Or, if a plan had been made, it was one which had been completely upset by the rapid successes of the enemy. In fact, as has been shown already, Badoglio had little idea of how the fight was going on his front; Buongiovanni was in the dark regarding the general situation except for the calls which came from Cavaciocchi; and Cavaciocchi, who saw his own danger, had played his cards too soon, and had nothing left. Krauss records the satisfaction he felt when he observed that the additional troops given to the IV. Corps on the eve of the battle were sent forward instead of being held in reserve.

By the evening the situation was very favourable to the attacking forces. Stein was pouring troops through the breach made by the Silesians, and was making good headway with the 60th Austrian division on their right, while the Alpenkorps; Burer and Scotti had broken through the lines opposite Tolmino, and in several places had gained the high ridge dominating the head of the Judrio valley. Krauss was still held up at Saga and on Polouinc, and the Bosnians had gained no more ground. But the break-through between Tolmino and Caporetto had made these positions untenable.

At Cividale, where Capello had his headquarters, and at the Comando Supremo in Udine, the first news that came from the IV. Corps and the absence of news from the XXVII. made a grave impression. Capello sent up the army reserves by the valley roads, and dispatched Montuori to direct the "left wing" (the IV. and VII. Corps). This was a step which might with advantage have been taken earlier; indeed, the II. Army might well have been further divided and, if necessary, made into an army group. It was too large, and covered too wide a front, for a single army command.

By evening the magnitude of the initial enemy success was clear, though it was not yet clear to what extent the whole Italian left wing was crumbling. There seemed good reason to hope that the advance might be blocked in the narrow valleys west of the Isonzo. But by nightfall both the IV. Corps and the 19th Div. were practically broken in pieces. Saga had to be abandoned owing to the break farther S., and the 50th Div., or what was left of it, retired into the Val d'Uccia, and on to the ridge of the Stol, which was reached later by the remnants of the 43rd, who had held their own bravely, but were in great part cut off when they attempted to come back across the Isonzo. A gallant detachment (Alpini and details of the Etna brigade), finding retreat impossible, held out for days on Monte Nero till the battle had gone far to the W., and all their food and ammunition were gone. The 46th Div. was practically destroyed, many having surrendered when they found the enemy at their backs, and others having joined the masses of supply service troops which were now filling the roads. The 62nd Div. (VII. Corps) was beginning to be attacked at Lufo, while its left was extending to occupy Monte Matajur and join hands with the 53rd, which had been dispatched by Capello to block the Natisona valley. The 3rd Div. was still in its old position, but it was now being attacked in front and its right was uncovered by the defeat and practical destruction of the 19th

The right wing of the 19th was still holding on Globocak, and had been reinforced by the 1st Bersaglieri Brigade; Alpine troops still held a line down to the river, though they had been driven off their original positions on Krad Vrh, and troops of the 64th were being brought back from the left bank to strengthen this line. It was obvious that the positions on the Bainsizza could not be maintained. Capello had already transferred Badoglio's division beyond the river to the command of the XXIV. Corps (Caviglia), and the order had been given to Caviglia and Albrici to withdraw their troops to their main lines of defence and to the former to prepare for a retreat across the Isonzo.

At this moment the most dangerous point appeared to be the extreme left wing, where the 50th Div. had lost touch with the Carnia force, and only the Potenza brigade, of three regiments, but much weakened by disease, was available as a reserve. And the Potenza brigade was wanted farther south. Two Alpine groups were already on the way to this critical point, having been dispatched the day before, but it was clear that Krauss would try to push through by this route, the shortest way to the Tagliamento. The occupation of Caporetto threatened to open another route nearly as short, but the possession of Monte Maggiore and the Stol, together with Monte Matajur, gave good hope that the advance of the enemy might be quickly brought to a halt when it had outrun the protecting fire of its own guns. Cadorna ordered the Carnia force to occupy Monte Maggiore, and block the Val d'Uccia "at all costs," and sent up a division to support the troops on the Stol. He gave orders for resistance to be made on three successive lines, but all of these radiated from Monte Maggiore, which was the key position. He gave orders for resistance on these lines, but at the same time he directed that plans and orders should be drawn up for a general retreat to the Tagliamento. This was a precaution only; at the moment, though the situation looked grave, there seemed little reason to doubt the capacity of the II. Army, and the reserves, already under way, to stem the enemy's offensive.

Next morning Cadorna warned the Duke of Aosta of the danger of the situation, and directed him to send his less mobile heavy artillery W. of the Piave and prepare for a retreat beyond the Tagliamento. Tassoni, who commanded the Carnia force, was also directed to prepare for a withdrawal of his troops.

The news on the morning of Oct. 25 was increasingly grave. Krauss was pressing upon the Stol, and finding a weak resistance; the Potenza brigade was falling back from Creda; Monte Matajur had fallen, practically undefended. Other positions were seriously threatened, and there was no confidence that they would be held. For it was now known in Cividale and Udine that the behaviour of some of the troops had been very unsatisfactory, that men of some units had been quick to surrender, while others had retreated before they were heavily attacked. And this unexpected lack of spirit was communicating itself to some of the reserves. These had a difficult task in getting to the scene of action, for as they marched up the narrow mountain roads they were met by ever-increasing masses of fugitives, the bulk of these belonging to the non-combatant services. The confusion and congestion on the roads may be estimated from the fact that in the area of the IV. Corps alone the number of non-combatant troops exceeded 30,000. Somehow the word went round, among combatants and non-combatants alike, that the war was over and that there was nothing to do but "go home." Perhaps the cry was raised by enemy troops disguised in Italian uniforms, for some of these were found; more probably it was started by some who had drunk in the Socialist catchwords, pronounced by the deputy, Signor Treves: "This winter no one must be in the trenches"; who had believed the promise, that if they laid down their arms the enemy would do likewise. It was an extraordinary case of collective deception, which hastened the break-up of Capello's whole left wing.

A gallant resistance was still being made at various points, notably at Luico and Globocak, but the enemy had broken through at several positions of vital importance, and, as has been said, the reserves were becoming entangled in the crowds of fugitives, and some of them were becoming infected. On the

afternoon of Oct. 25 Capello, who doubtless had no more against an illness to which he ought perhaps to have given in sooner, and had been told by the chief medical officer of the army that he must resign his command, proposed to Cadorna an immediate retreat to the Tagliamento. His argument was that it was useless to send in more reserves to the chase among the hills west of the Isonzo; that the only way to remedy the situation was to withdraw the bulk of the armies "from close contact with the enemy under the protection of vigorous rearguard actions," and so make possible the organization of a solid defence and eventual counter-attack. Cadorna agreed as to the probable necessity of retreat, but he was doubtful as to whether it should be immediate. He felt that unless he could delay the enemy advance down the Natsons and Judrio valleys by more than a mere rearguard action he ran the risk of having his centre and right, and all the mass of troops in the Udine plain, cut off from his bases. Monturzi, who now succeeded Capello in command of the II. Army, was of opinion that he could hold on a line from Monte Maggiore to Monte Carnizza and thence across the valleys to Monte Korada. Cadorna decided to attempt the further stand, and, as the II. Army was obviously too large for movement, the left wing was given to Gen. Etta, late of the KEK. Corps, and the right to Gen. Ferrero, late of the XVI., while Gen. Sagramoso, who commanded the XIV. Corps, in reserve on the Isonzo, was charged with the duty of organizing a reserve line of defence on the river Torre. Tassoni, Di Robilant (IV. Army) and the Duke of Aosta were all warned to hold themselves in readiness for retreat, Di Robilant being told to send his big guns at once W. of the Piave to between Pederobba and Montebelluna. The VIII. Corps was detached from the II. Army and given to the Duke of Aosta, who was already forming a reserve line on the western rim of the Carso, preparatory to the withdrawal of his main body. Gen. Di Giorgio was sent northward, with two divisions from the general reserve, to occupy both banks of the Tagliamento in the region of Pinzano.

Cadorna hoped to hold, for a time at least, but at midnight on Oct. 26 he was wakened to hear the news that Monte Maggiore had fallen. He at once drew up the orders for a general retreat beyond the Tagliamento, and his plans were already matured for the longer retreat, across the Piave, which he foresaw would probably be necessary. Next day the weak resistance of the II. Army rearguards and the increasing number of disbanded soldiers confirmed his impressions. He saw, too, that there was, literally, no room to bring the II. Army back in good order. He was determined to keep the southern roads clear for the III. Army, and this meant that the retiring units of the II. Army would be so hampered by disbanded soldiers and fugitive civilians that most of them could scarcely hope to get back as units. In the circumstances he had to count out the greater part of the II. Army and fall back on a line that could be held by a smaller number of troops. It was only to gain time that he attempted a stand on the Tagliamento. Provisional orders and plans for a retirement to the Piave were issued on Oct. 29. The mournful retreat began on Oct. 27, and the prospects were rendered still more serious by the fact that the Tagliamento came down in sudden and violent flood. The fords could not be used; several existing bridges were carried away, and attempts to throw new bridges were unsuccessful. The danger of losing more men and guns on the retreat became still greater.

Fortunately for Italy, and for the cause of the Entente, the Germans and Austrians were, in part at least, outrunning their transport. Krauss complains that only he and Kraft von Delmensingen, Below's chief-of-staff, had been inspired by adequate ambitions for the attack. The objective had been Cividate, or, at best, the Tagliamento. Kraft thought they should have had the Adige in view. Krauss expressed the opinion that the real objective should have been Lyons. Without taking Krauss's aspirations too seriously, it may well be believed that if the German and Austrian Commands had worked out a bigger plan they would have done even more than they did do. But the transport difficulties were very great; Germany could

not spare troops or material to make an unlimited effort on the Italian front, and the unexpectedly weak resistance of the Italian II. Army could hardly have entered into the calculations of those who were bound not to take too many risks. Krauss himself admits that if the Italians had held the Stol in strength his own move would have been frustrated.

Krauss, Stein, Besser, and Scotti were very quick in their pursuit, and Berres paid for his haste with his life. He was shot by an Italian *carabiniere* at the gates of Udine on Oct. 28, the day on which his advanced guard entered the town, less than 20 hours after Cadorna and his staff left for Treviso. His place was taken by Hofacker. The Italian covering troops were delaying the enemy advance, and giving time for the III. Army, fighting a strong rearguard action, to come back across the Tagliamento. Henriquez had difficult mountainous country to cross before he reached the plain, and both he and Wurm were held up on the Isonzo, where the bridges had been destroyed by the retreating Italians. The critical days for the Italians were Oct. 30 and 31, when the pressure from the N. and E. threatened the flank and rear of the III. Army, whose task had been rendered more difficult by the fact that the permanent bridges at Casarsa had been blown up prematurely, owing to a false alarm. Many guns had to be left on the eastern bank, including 46 heavy batteries, which had been brought all the way from the Bainsizza. The Tagliamento was falling, however, and a number of troops succeeded in fording the river. It had been impossible to keep the Casarsa bridges for the III. Army, as several units of the II. and a large number of disbanded men had been forced down by the pressure from the north. But on the afternoon of Oct. 31 the Duke of Aosta was able to inform Cadorna that all of his rearguard, with the exception of four brigades, who were holding a defensive bridgehead covering Madrisio, had passed the Tagliamento. The bulk of this rearguard crossed the same evening, and only a small bridgehead was held at Latisana. A considerable number of II. Army troops, having failed to cross the river at Casarsa, were coming down towards Latisana pursued by Scotti's vanguard and threatened on the flank by Henriquez. Some of these succeeded in crossing at the Latisana bridges, but the enemy attacked in considerable force the following day, and a large number of Italians were cut off and taken prisoners. By the evening of Nov. 1, the left bank was entirely in the possession of the Austro-German armies.

Krauss tells a remarkable story according to which both Below, with Scotti's group, and later, Goiginger, with the right wing of Henriquez's army, wished on reaching the Tagliamento to swing S., and cut off the Duke of Aosta's army, which, Krauss maintains, was still some distance to the east. According to Krauss, Boroëvic refused to allow Scotti to encroach upon his line of march, and forbade Gen. Ludwig von Goiginger to come S. of the line marked out for the II. Isonzo Army. But before Scotti was in a position to carry out the manœuvre which Below is reported to have proposed, the bulk of the Duke's army was already across the Tagliamento, and his last four brigades were more than capable of dealing with anything Scotti could then bring against them. Before Goiginger was on the spot the whole of the III. Army had passed the river and there were on the eastern bank only the broken troops who had come down from the N. in a last attempt to find a way across. Krauss's remark, that "Boroëvic had saved the Italian III. Army," has no foundation. Boroëvic knew more about the III. Army than the German staff officers or Goiginger, who were Krauss's authorities. Krauss also asserts that the manœuvre would have led to the capture of the King of Italy and of Cadorna and his staff, a statement for which, though furnished by "a neutral crowned head," there are no grounds whatever.

Cadorna did not expect to stay long on the Tagliamento, but he did hope to hold up the enemy long enough to give adequate time for the retreat of the Carria force and the IV. Army, and to organize a strong defensive line on the Piave. His weak point was the stretch of the river W. of Tarcenno, for which Krauss and Stein were making with all speed. Two divisions under Di Giorgio had been dispatched to hold this line, but

their march, at right angles to the line of the retreat and athwart the long streams of retiring troops and civilians, had been very difficult. Stein's troops, however, failed to cross the Tagliamento, their attempts being repulsed with heavy loss. It was left to Krauss's Bosnians, after vain attempts to ford the river, to cross by the half-broken railway bridge at Cornio, on the evening of Nov. 2. The Bosnians had crossed by nine o'clock, surprising and driving back the small detachment watching the bridge. The following morning Di Giorgio was strongly attacked at Pinzano and Krauss established a sufficient bridgehead. On Nov. 4 Di Giorgio's left was pushed back still farther, endangering the line of retreat for the Carnia force divisions, and once more threatening the whole Italian line with envelopment from the north. For Stein was sending troops across to reinforce Krauss, and incidentally, according to Krauss, to claim the credit which was due to the Bosnians alone.

On the morning of Nov. 4 Cadorna ordered the retreat to the line of the Piave, and that night the troops holding the line of the Tagliamento resumed their march westward. Cadorna's main preoccupation was now for the IV. Army, which had been slow in getting under way, and for the Carnia force. Di Robilant wished to hold on in Cadore. It was natural, perhaps, that he should not have realized fully and at once the urgent necessities of the situation, but his hesitation to act promptly in accordance with Cadorna's instructions exposed him to the danger of having the retreat of his right wing cut off. For the safety of his route to the new positions assigned to his army depended now on the ability of the left wing of the worn-out II. Army to hold back the pressure of Stein's troops. Krauss's group had been sent N.W. through the mountains to the Upper Piave, to establish contact with Krobotin's X. Army and try once more to envelop the Italian left wing. This move cut off the greater part of Tassoni's Carnia force, caught between Krauss and Krobotin.

Di Giorgio's force and the rest of the covering troops of the II. Army slowed down the enemy advance, holding for some time on the Livenza and the Monticano. The III. Army, to which the VI. Corps had now been attached, was coming back steadily, though Boroević's advance guards were giving little peace to its covering troops. Cadorna had intended to put the battered units of the II. Army in reserve at once, to be reorganized and refitted; but the delay in the retreat of the IV. Army made it necessary to keep the II. and XXIV. Corps as part of the river defence force, the II. Corps in line from the Vidor bridge to Norvesa, the XXIV. in reserve, both under the command of Di Robilant, to whom was to be entrusted the sector from the Montello to the Brenta. The converging retreat of the IV. Army was being carried out with much skill, and Di Robilant's troops succeeded in bringing away with them a great amount of material, but several detachments were cut off, including remnants of the Carnia force, which had been attached to the IV. Army for the latter part of the retreat.

By Nov. 8 the bulk of the IV. Army had succeeded in coming into line between the I. and the III., though part of the I. Corps was still on the road between Ponte delle Alpi and Feltre. On Nov. 9 and 10 the last covering troops of the II. and III. Armies crossed the Piave, from Pedocrobbà to the sea.

The line chosen to defend the fortunes of Italy implied a withdrawal of the right wing of the I. Army. This contingency had been studied, and preparations for a new line had begun, during the Austrian offensive in 1916, and Cadorna had ordered the work to be continued during the interval. Pecori-Giraldi retired from Asiago and Gallio, and based his right on the fortified lines of the Meletta group. This formed a salient, for the line marked out for the IV. Army E. of the Brenta ran considerably farther south. Di Robilant had taken over the XVIIII. Corps from Pecori-Giraldi, and it had been gradually withdrawn from its old positions to hold a line that ran from near San Marino in the Brenta gorge nearly due E. towards the Piave, keeping always in touch with the IX. Corps as the latter came down from Cadore. The IV. Army now held the line from the Brenta to the Piave, and the short stretch of the river as far as the Montello. The rest of the river line was held by the

Duke of Aosta, with the VIII. Corps on the Montello, the II., which had been in line between Pedocrobbà and the Montello, occupied in preparing defensive positions, going back to be rested and re-fitted with the rest of the II. Army.

Reserves were coming in fast from the depôts, including the young class of 1899. French and British divisions were already in Italy, and others were on the way. Many units of the II. Army were being rapidly reorganized and were soon to come into line again. But for the moment the Italians had only the I., III. and IV. Armies to hold the new line; and the III. and IV. Armies had been sorely tried by the retreat. There had been a serious breakdown in the morale of a part of the II. Army, which had been largely responsible for the extent of the enemy's initial success, and the tremendous strain of the retreat had naturally been responsible for further breakdowns. The behaviour of the majority of the troops had been beyond all praise, but all were now worn-out, physically fatigued by the long trial of the retreat and suffering from the great moral depression caused by unexpected defeat and retirement from the lines they had held so long. Diaz, who took over the command from Cadorna on the morning of Nov. 9, had to face a situation that seemed almost desperate. The Italian armies had lost some 320,000 men in killed, wounded and missing, the number of prisoners being estimated at 265,000. The bulk of the II. Army had to be counted out altogether, and the total number of troops to be reorganized and re-fitted was over 300,000. More than 3,000 guns had been lost, and over 1,700 trench mortars. There was shortage in equipment of every kind. It seemed scarcely possible that these greatly weakened forces could resist the renewed attacks of the victorious armies which had followed so closely upon their heels. Fortunately, the plans for defence had been well and truly laid by Cadorna in the limited time that was available, and, still more fortunately, his foresight had caused elaborate preparations to be made on Monte Grappa. Roads had been built and gun positions prepared, and reservoirs made for water; trenches had been dug and strong redoubts constructed at various important points, though the defensive system was not completely finished when the enemy attacked at Caporetto. These works had been ordered with the double object of strengthening the defences of the Val Brenta against an attack from the N., and of providing against the possibility of a retreat to the Piave, which Cadorna had been compelled to consider once before, in May 1916. It was due to this forethought that resistance on the line now chosen was possible.

Diaz had little breathing-space, though some days were required before the enemy could prepare for an attack in force upon the new line. For Conrad saw a chance, and, though he was short of troops, he struck at once, while calling for reinforcements to be sent to him for the eastern armies. He attacked Pecori's troops on Nov. 10, as they were preparing to come back to the line already indicated. When they had taken up their positions in the Meletta-Badenecche salient, Conrad's attacks were renewed, and for 10 days the fight continued, but brought no success to the Austrians, who lost heavily. Conrad had brought to this sector of the front all the troops who had been in the Fassa Alps, but he still felt himself too weak for the end he had in view—a break-through to the plain, and he urged continually the dispatch of further reinforcements. Meanwhile Boroević had tested the river defences at various points. On Nov. 12 a crossing was effected at Zenson, some 17 m. from the mouth of the river, and a small bridgehead was established in the loop formed by the curving stream. Various other attacks at San Donà, Intestadura, and the Grave di Papadopoli were unsuccessful, and the troops at Zenson could make no headway. Down by the mouth of the river Hungarian troops succeeded in establishing themselves between the Old Piave and the main stream, but they were unable to gain any more ground. As the days went on, other attempts to cross the river were defeated by the III. Army, and on Nov. 16 an attack in force failed completely. The Austrians crossed at various points N. of Ponte di Piave, but were repulsed with heavy casualties, losing some 1,500 killed and nearly as many prisoners. After this

fellows Boroevic abandoned his attacks. The river was a serious obstacle; the Italian defence was sound; it was clear that prolonged and careful preparation was necessary.

Conrad and Boroevic were making no headway, but a more dangerous attack was being conducted by Krauss, between the Brenta and the Piave. Krauss, who now had Krobatin's troops under his orders, and subsequently drew reinforcements from Stein's group, wished to organize a double drive through the Brenta and Piave gorges, and reach the plain by the tactics he had successfully employed in the Plezzo basin. Attempts to break through by the valley roads were quickly frustrated. Krauss blames his divisional commanders, who, he says, were opposed to these tactics, and could not make up their minds to a resolute attempt. An effort was finally made in the Quero gorge on Nov. 17 and failed badly. Nor were the numerous gallant attempts to capture the all-important ridge of Monte Tomba-Monfenera, which ran down from the Grappa massif to the Piave, more successful in breaking through the thin Italian lines. The struggle at this point lasted for five days, from Nov. 18 to 22, and the Italian IX. Corps, under Ruggieri Laderchi, fought a great fight. The critical day was Nov. 22. In the morning Krauss's troops, the Bosnians and the German Jäger, who had both been heavily punished already, made a great effort to break through. The attacking columns reached the crest of Monte Tomba, but their bolt was shot; and Monfenera still held firm and raked their left flank. The Italian position, however, was critical in the extreme, for the line had become very thin, and there were no reserves to speak of. At dusk a message came from Di Robilant that he was sending up a brigade of the VI. Corps, which had been drawn from the reserve of the III. Army. A later message promised another brigade. Ruggieri Laderchi took his courage in both hands, and, without waiting, counter-attacked with his own battle-worn troops. He drove the enemy off the ridge, except at one point where a gallant handful of men still clung to a knob of hill that had been made into a machine-gun redoubt. Next day the reserves arrived, and the line was firmly established. Only one more attack was made in this sector and both Jäger and Bosnian divisions had to be withdrawn and re-made.

When he failed in his first attempt to go through in the valleys, Krauss resigned himself to a frontal attack upon the mountain lines between the Brenta and the Piave. He claims justly that the conditions were very difficult, but he made a big effort. The attack with his centre and right began on Nov. 27, while he was still hammering against Monte Tomba with his left, and he gained ground to begin with, driving back the Italian outpost lines in the Grappa sector. For a week the attack lasted, but little progress was made. The 22nd Schützen and Edelweiss Divs. who had broken through at Plezzo, and the 94th, from Krobatin's army, gained a little ground on the right, the Alpine troops of the 22nd capturing the summit of Monte Pertica, but the German Alpenkorps and the Austrian 50th, which had passed to Krauss from Stein's group, to replace the battered Bosnian and Jäger divisions, made no headway against the salient of Solarolo and Spinocchia, or against the Tomba-Monfenera line. They succeeded in taking various positions, among them Spinocchia, but they could not hold them against the Italian counter-attacks, and further attempts to extend the success gained on the right were equally unsuccessful. On Nov. 26 the Edelweiss made a great attempt to capture Col della Berretta, but were repulsed, and a pause followed.

The breathing-space was needed by Di Robilant's troops, for the XVIII. and IX. Corps had been very highly tried, especially the latter. On Nov. 22 the situation in the Grappa sector had been improved by the arrival in line of the XXVII. Corps, already re-made, under the command of Di Giorgio; and the Corps distinguished itself greatly in the fighting which followed. But a new attack was preparing, when the situation was eased by the arrival in line of the British and French divisions which had hitherto been waiting in reserve. On Dec. 2 three British divisions under Lord Cavan took over the Monte Tomba sector, and a similar French force under Gen. Duchesne

relieved Ruggieri Laderchi's IX. Corps in the Monte Tomba region. It was expected that both these points would be the object of early attack, but as it turned out they were both left unmolested. Conrad and Krauss continued their attempts to break through on the mountain front, but Krauss confined his efforts to the positions west of Monte Grappa and the worrying Solarolo salient. Boroevic remained quiet on the Piave front, and the rest of Below's army was now practically a reservoir for Krauss, who drew divisions both from Scotti and from Hofacher, as well as from Stein. Krauss was finding the question of communications very difficult, especially for his artillery ammunition, and could not open his new attack till Dec. 10. On Dec. 3 Conrad, reinforced by fresh troops but still complaining that he was starved for means of attack, opened a heavy bombardment on the curve of the Italian front from Monte Sisemol to E. of Monte Badenece. Next day, by a skillfully conducted attack following a liberal use of gasshells, he pinched up the Meletta-Badenece salient, occupying both Tondarecar and Badenece and taking Monte Fior and Castelgomberto in the rear. Next day Conrad's eastern columns pushed down quickly towards Foza, but were held by a rearguard of Bersaglieri and Alpini who fought off the attack until a new line was established farther S., covering Valstagna and the mouth of the Frenzela valley. But more than 11,000 prisoners were taken as a result of the gas bombardment and the breaking of the line at the base of the salient. It should be said that on this occasion as at Caporetto the Italian gas mask proved very unsatisfactory. The army was shortly afterwards equipped with the British mask.

The loss of the Meletta-Badenece positions left another salient exposed to Austrian attack. The hills S. of the Valle dei Bonchi were now open to artillery fire and infantry attack on three sides, and, after a fortnight's preparation, on Dec. 23 Conrad launched a new attack on the Italian lines between Monte Sisemol and the Frenzela valley. The salient was quickly wiped out, several thousand prisoners were taken, and both Col del Rosso and Monte Melago were captured. Next day the Italians counter-attacked, and re-took Col del Rosso and Monte Melago. They established themselves firmly in their reserve lines, and repulsed another attack, the last, on Christmas Day.

Between Conrad's two efforts Krauss had made a determined attempt to drive the Italians off the Grappa line. His command was now increased to the strength of 10 divisions, six Austro-Hungarian and four German, and he did not spare his troops. He opened his attack on Dec. 11 by a push on each wing of his front, from the Brenta valley and Monte Pertica against Col della Berretta, and against both sides of the Solarolo salient. The attack from the N.E. was carried out by German troops, while W. of Solarolo and Col dell' Orso were picked Austro-Hungarian divisions. After the first day, when the Brandenburgers of the 5th Div. took Monte Spinocchia, the N.E. outwork of the salient, the Germans could make no more headway, in spite of repeated attacks, in which they were supported by the 94th Austrian Div. on the other side of the salient. Besides the 5th, the 200th and the Jäger also took part in the attack, which was renewed again and again during 10 days, but no further progress was made. Krauss, who reports that he was not allowed to have the German troops on the spot more than 48 hours before they were to attack, claims that this "excessive sparing" of the troops worked out badly, for they suffered from insufficient acquaintance with the terrain. However that may be, the German divisions, in spite of a great expenditure of shells, could gain no ground. Sometimes a position was gained for a few minutes, only to be lost again. The fighting was very stubborn.

Krauss had better success with his right wing. At the end of four days' hard fighting the Austrian 4th Div. had taken Col della Berretta and Col Caprile, though their occupation was not firmly established, and the Italians were continually counter-attacking. Four days more, and Krauss's men had captured Monte Asolone, which looks down the Valle di Santa Felicità to the longed-for haven of the plain. This was the term of the Austrian advance. On Dec. 20 the Italians counter-attacked, and won back a good deal of the lost ground, the last move in the



long struggle. Krauss accepted failure for the moment, hoping for an early spring offensive farther west. Five days later the snow came, the heavy winter fall that was at least a month late.

The Austrians and Germans were much favoured by the late coming of winter, which greatly prolonged the strain on the hard-fried armies of Italy. But it gave also to the defending troops the chance to re-make at once a shaken reputation.

The recovery of the Italian army on Monte Grappa and the Piave, after the initial failures and the heart-breaking experiences of the long retreat, was a remarkable feat of courage and will. It will be clear from the narrative here given that the Caporetto disaster was not due solely to the cause which was at first generally accepted as the explanation of a defeat so sudden and so overwhelming. Cadorna's *communiqué* of Oct. 28, which condemned in the strongest terms the behaviour of "detachments of the II. Army" and gave this as the cause of the enemy success, was too simple an explanation, and was, moreover, unwise. Inevitably, the impression was left that the failure in *moral* had been more widespread than was actually the case. For in the whole course of the war no such candid announcement had ever been made by any commander on either side; it was assumed, especially abroad, that if Cadorna confessed this much there was far more that he did not tell. Cadorna wished to arouse both army and country to a sense of the situation, and to indicate clearly the results of the peace propaganda against which he had protested. In Italy the result was good on the whole, for the country was stung to a great effort. But Cadorna's open condemnation of his soldiers was strongly resented in many quarters.

There is no question about the weak resistance of certain units in line, nor can it be denied that other troops, among the reserves, became temporarily infected with a spirit that led to what many observers likened to a strike. Extreme war-weariness and socialist propaganda had their offspring in these failures. But the failures were sporadic only. The stories current at the time and long after, of a preconcerted agreement for surrender to the enemy, have no foundation whatever. The defending troops were subjected to a very severe trial and some of them failed. Their failure led to disaster. How far might disaster have been lessened or averted if the preparations for the Austro-German attack, and the actual conduct of the defence, had been different?

The narrative has drawn attention to certain errors and misunderstandings which contributed to the enemy success. First among these, in order of time, was the difference of opinion between Cadorna and Capello as to the right course to pursue in face of the coming attack. It is difficult to avoid the impression that Capello was only half-hearted in adopting, and in directing his corps commanders to adopt, the line of action indicated by his chief. Whether Cadorna or Capello was right in idea is a question which will remain a subject of contention, though Cadorna's arguments seem almost unanswerable. The point is that Capello would seem to have interpreted Cadorna's instructions as to counter-offensive action in too liberal a fashion, influenced, perhaps unconsciously, by his own wish to attempt a big counter-stroke. The fact remains that the bulk of the II. Army was still aligned for an offensive, and though a complete modification was impossible, certain changes might have been made. The situation of the IV. Corps was especially unfavourable for defence, the front-line positions of the 46th Div. being practically untenable. The Sleme-Mrzli position ought to have been abandoned for the Pleca-Selisce line, which was as strong naturally as the other was weak. Despite the weakness of the Sleme-Mrzli line, both dominated and enfiladed, despite the practical certainty that it could not be maintained against a resolute offensive in force, the enemy attack found a large number of Italian guns, including many of medium calibre, stationed well in advance of the Pleca-Selisce line. Although various commanders had reported the Sleme-Mrzli line indefensible, steps which should have followed logically had not been taken.

It is obvious also—after the event—that if the reserves for the IV. Corps had been close at hand, on the Stol and higher up the Natisevo valley, the inrush of the enemy might have been stemmed. Such dispositions were clearly desirable, even before

the event. There was, in fact, a tendency to underestimate the amount of time necessary for the transference of troops from one position to another. On the other hand, Cavaciocchi did not make the best use of the reserves which he had. Cadorna's efforts had not succeeded in making all of his subordinates grasp the principles of defence in depth, or of "elastic" defence. It was only later that the theories upon which he had for long insisted were understood and applied. And it may be admitted that the tendency to push the infantry too far forward was a necessary consequence of the policy which had left the guns aligned as for an offensive. The failure to hold in strength the roads on both sides of the Isonzo has never been satisfactorily explained. All that can be said is that an attack along these roads was apparently unexpected; that it came; and that it had much to do with the disaster that followed. It is clear that there was insufficient collaboration between the commanders of the three corps occupying the front attacked. This was doubtless due to the extreme pressure of the days which preceded the offensive, and to the many modifications which had to be made during these days. But it remains a grave omission.

The failure of the Italian artillery to carry out the general order of counter-preparation expressly given by Cadorna, and repeated in no less categorical terms by Capello, had an undoubted effect upon the course of the battle. The attacking troops, both gunners and infantry, found their task unexpectedly lightened by the absence of a heavy return fire upon their batteries, trenches, and zones of concentration. The Italian infantry, waiting under a crushing bombardment, were puzzled and disheartened by the silence of their own guns. This holding of the Italian fire, like the failure to appreciate the necessity for defence in depth, is explained by the fact that as regards the practice of defensive tactics the Italians were some two years in arrears. Cadorna and a few others had realized the progress made in attack methods and the necessity of meeting them with new methods of defence. The realization had not spread downward. The Italian armies on the Julian front had been so busily occupied in attack that they had not worked out the application of new defensive methods. They had had no recent practice in meeting an attack on the grand scale. It was this lack of practice, no doubt, and a false confidence based on obsolete experience, which led to the belief that even if the opening phases of the battle were unfavourable to the defence, there would be ample time to restore the situation. This spirit was widely evident in the disposition of troops and guns.

When retreat became inevitable, the prospects might well have seemed desperate to those who had to organize it. For the army, long used to the war of positions that had been the rule for 28 months, was in no condition to move. The retreat, with all its confusion, its mistakes and its tragedies, remains an astonishing achievement. The resistance which followed it, when the retiring armies turned and stood at bay on the mountains and on the Piave, was the greatest of Italian victories. (W. K. McC.)

**CAPPS, EDWARD** (1866- ), American classical scholar, was born at Jacksonville, Ill., Dec. 21 1866. He was educated at Illinois College (A.B. 1887) and Yale (Ph.D. 1891). In 1890 he was appointed tutor at Yale. In 1892 he joined the faculty of the newly-founded university of Chicago as professor of Greek language and literature, remaining such until 1907. In 1903 he was special lecturer at Harvard, and during the next two years studied at Athens and Halle. During 1906-7 he was managing editor of *Classical Philology*, in 1907 was elected president of the Classical Association of the Middle West and South, and the same year was called to Princeton as professor of classics. In 1914 he was elected president of the American Philological Association, and in 1917 was Turnbull lecturer on poetry at Johns Hopkins. In 1918 he was appointed head of the American Red Cross commission to Greece with the rank of colonel. In 1920 he was appointed minister to Greece, resigning in March 1921 and returning to Princeton. A leading authority on the Greek theatre, he contributed much to philological journals.

His works include *The Stage in the Greek Theatre* (1891); *From Homer to Theocritus* (1901); *The Introduction of Comedy into*

*City Dionysia: a Chronological Study in Greek Literary History* (1903) and *Four Plays of Menander* (1910). He was editor-in-chief of the University of Chicago Decennial Publications, 29 volumes.

**CARINTHIA** (see 5,336), a territory of the Austrian Republic, is bounded N. by Styria and Salzburg, E. by Yugoslavia and Styria, S. by Italy and Yugoslavia and W. by Tirol.

**Area and Population.**—The total area of Carinthia before the World War was 4,005 sq. m., and the pop. (in 1910) 396,200 (92 per sq. mile). The terms of peace deprived Carinthia of Kanal-Thal together with Tarvis and the lead-mines of Raibl, which were given to Italy; the district of Seeland, S. of the Karawanken, abandoned by Austria; the valley of the Mies with the lead-mines of Mies and Schwarzenbach and the district surrounding the mouth of the Lavant, which was given to the Southern Slavs. The district of Tarvis had (1910) some 7,700 inhabitants, of whom 5,700 were Germans. The districts given to the Southern Slav state then had 17,500 inhabitants, of whom 3,200 were Germans.

It was arranged that the basin of Klagenfurt should decide its future allegiance by plebiscite. This plebiscite was taken in two distinct zones, the outer (Zone I. or A) of which reached nearly to Klagenfurt, the capital of the district, and comprised an area of 667 sq. m., with (1910) 72,138 inhabitants, of whom 31.5% were German; the inner (Zone II. or B) included a smaller portion of the district of Klagenfurt, and comprised an area of 132 sq. m., with (1910) 58,600 inhabitants, of whom 89.7% were German. The voting in Zone I. resulted, on Oct. 10, 1920, in a choice of allegiance to Austria by 59.1% of the total votes; Zone II., therefore, went Austrian also.

In the Carinthia of to-day (apart from the two above-mentioned zones) 94.8% were German in 1910. Most of the Slovene population is in Gail-Thal. As Zone I. was occupied by the Southern Slavs at the time of the Austrian census of 1920, the total number of the inhabitants of the Carinthia of to-day is unascertained. The portion under Austrian rule in 1920 (inclusive, therefore, of Zone II.), had 297,275 inhabitants (99 per sq. mile). In 1910 the pop. was 299,091; in Zone I. 72,138. Altogether, therefore, the present-day Carinthia had, on Dec. 31, 1910, 371,229 inhabitants (119 per sq. mile). The population of the district which exercised the plebiscite was in 1910 93.3% Roman Catholic and 6.5% Evangelical. The proportion of males to females was as 1,000 to 992; in 1920, however, the proportion was as 1,000 to 1,067.

For administrative purposes Carinthia has been divided into seven districts and an autonomous city—the capital, Klagenfurt (pop. 26,111 in 1920). Other important places are Villach (pop. 21,896); St. Veit, until 1918 the capital of Carinthia (pop. 5,927); Wolfsberg (pop. 5,808); Spittal (pop. 4,406) and Bleiberg (pop. 2,861). In the Electoral Zone I. are Volkermarkt (pop. in 1910 2,631) and Oberfließach (pop. in 1910 3,194).

**Agriculture.**—Of the Carinthia of to-day (with the exception of the Electoral Zone I.) 8.6% of the soil was unproductive in 1900. Of the productive areas 15.6% consisted of arable, 0.4% gardens, 11% meadowland, 25.1% grazing land (mostly high-lying), 47.7% woodlands (mostly coniferous). Stock-raising is well developed, but suffered severely during the World War. In 1918 there were 164,309 head of cattle (of which 66,501 were Milch cows) and 97,766 swine.

The Carinthian breeds of cattle (Lavanttaler and Möltaler) and of horses are greatly prized. Bee-culture, in conjunction with the cultivation of buckwheat, is actively pursued.

**Minerals.**—The mineral wealth is still not worthy, notwithstanding the loss of important mining districts. The gold-mines of Tauern are not worked. Copper and antimony ores are being mined, but are not smelted locally. On the other hand, the output of lead (12,000 tons in 1915, or over 92% of the whole present output of Austria) and zinc (400 tons, or 54% of the whole output) ores is important in the Gail-Thaler Alps, especially in Bleiberg and Kreuth. Since the Raibl mines fell to Italy and those of Mies and Schwarzenbach to Yugoslavia, Bleiberg has regained its importance as the chief lead-mining centre in Austria. Consequently its products of lead and lead colours (white and red lead) are considerable.

The iron-mining industry, which was once widespread, is now active only at Hüttenberg, at the foot of the Sausalpe. The ore raised (in 1915 98,000 tons, or 5% of the whole output of Austria) is carried away from Carinthia to be smelted elsewhere. Lignite (*Braunkohle*) is found in many parts of Carinthia, especially in Lavant-Thal; the output of this, however, was in 1915 only 84,000 tons, or 3% of the whole Austrian output.

**Manufactures.**—Carinthia is richly endowed with water-power; but, in spite of that, its industries are inconsiderable. The most important are the manufacture of scythes (Himmelberg), the ironworks of Ferlach and Feistritz, the small-arms factory at Ferlach, all kinds of lead-ware, some paper and some woollen factories (Viktring) and machinery (Brückl). Klagenfurt and Wolfsberg are busy centres of the weaving industries and also of the manufacture of and trade in articles in products of wood—notably cellulose, lignine and pasteboard.

**Communications.**—Since the opening of the Tauern and Karawanken lines, Villach has become an important railway centre, being at the intersection of the Salzburg-Trieste-Vienna-Venice and Marburg-Franzenfeste (Hungary-Tirol) railways.

See Noebert, *Krebs, Länderkunde der österreichischen Alpen* (1913); "Das Klagenfurter Becken," *Geographische Zeitschrift* (1909); Martin Wutte, *Germanen und Slovänen in Carinthia* (1918), *Der Karawanken Abkommungsgebiet* (1920); Franz Heritsch, "Die österreichischen und deutschen Alpen," *Handbuch der regionalen Geologie* (vol. ii, part 9, 1915); Victor Conrad, *Klimatographie von Kärnten* (1913).

**CARLISLE, GEORGE JAMES HOWARD, 9TH EARL OF** (1843-1911) (see 5,341), died in London April 16, 1911. He was succeeded by his son, Charles James Stanley Howard (b. 1867), well known as a Unionist politician under the name of Visct. Morpeth. The 10th earl died Jan. 20, 1912, and was succeeded by his son, George Josslyn L'Estrange Howard (b. 1895).

**CARNEGIE, ANDREW** (1837-1919), died "captain of industry" and philanthropist (see 5,364), American at Lenox, Mass., Aug. 11, 1919. His ideals are shown by his benefactions and are best described by describing them. In 1910 he gave \$10,000,000 for establishing an Endowment for International Peace, "to hasten the abolition of international war, the foulest blot upon our civilization." This Endowment was planned to encourage studies in economics, history and international law so that misunderstandings of peoples be averted by increasing their knowledge of one another. After America entered the World War (1917) the Endowment gathered much international information and furnished it for use at the Peace Conference. In 1910, the Pan-American Union building erected in Washington by Carnegie at a cost of \$850,000 was dedicated. In 1911 he established his last and largest endowment, the Carnegie Corp. of New York, and before his death placed in its charge \$125,000,000 to be used for promoting civilization in whatever way seems best to the trustees. The variety of its activities is illustrated by the following: American Red Cross (\$1,500,000); Knights of Columbus War Work Fund (\$500,000); Y.M.C.A. War Work Fund (\$250,000); Y.W.C.A. War Work Fund (\$100,000); Library Buildings in Army Cantonments (\$320,000); Study of Methods of Americanization (\$204,000); National Research Council (\$5,420,000); Church Pension Fund (nearly \$325,000), and Simplified Spelling Board (\$110,000). In 1913 the Hague Peace Palace, given by Carnegie and costing \$1,500,000, was dedicated. Some of the best known gifts in addition to the above mentioned are: The Carnegie Institute of Pittsburgh, nearly \$29,000,000; the Carnegie Institution of Washington, \$22,300,000; the Carnegie Hero Fund Commission, \$10,500,000; the Carnegie Foundation for the Advancement of Teaching, \$29,250,000; the Carnegie U.K. Trust, \$10,000,000; the Scottish Universities Trust, \$10,000,000; the Dunfermline Trust, \$3,750,000; the Simplified Spelling Board, \$250,000; the Church Peace Union, \$2,025,000. By the close of 1918 he had erected 2,811 library buildings (1,946 U.S.A.; 660 Great Britain and Ireland; 156 Canada; 49 elsewhere) at a cost of more than \$60,000,000. He had provided 7,689 church organs throughout the world, costing more than \$6,000,000. To the Carnegie U.K. Trust, founded in 1913, he transferred the charge of all his existing and future benefactions other than university benefactions in the United Kingdom. He gave the trustees a wide discretion, and they have inaugurated a policy of financing rural library schemes rather than erecting library buildings, and of assisting the musical education of the people rather than granting organs to churches. In his will he provided that after certain enumerated bequests the residue of his estate (his family having already been provided for) should pass to the Carnegie Corporation. Appraisal of the estate, smaller than had been estimated, was made in 1912 and showed a net value of \$22,880,000. Since according to the law of New York only half of an estate can be assigned as public bequests in case husband, wife, parent, or child survive, the residue passing to the Carnegie Corp. was less than \$11,000,000. Before his death Carnegie had made public gifts, including those mentioned above, amounting to \$350,000,000. If he did not die poor, as he claimed every man should, he at least had given away all but a relatively small portion of his wealth.

His *Autobiography* appeared in 1920.  
**CARNOOK, ARTHUR NICOLSON, 1ST BARON** (1849- ), British diplomatist, was born in London, Sept. 19, 1849, the son

of Admiral Sir Frederick William Erskine Hamilton Nicolson, 10th Bart. (1815-99). He was educated at Rugby and Brasenose College, Oxford, and in 1870 entered the Foreign Office, where he was for some time assistant private secretary to Lord Granville. In 1874 he was attached to the British Embassy in Berlin, and after occupying a succession of minor diplomatic posts became in 1885 *chargé d'affaires* at Teheran. From 1888 to 1893 he was consul-general at Budapest, in 1894 secretary of embassy at Constantinople, from 1894 to 1895 agent in Bulgaria, and from 1895 to 1904 minister in Morocco. In 1899 he succeeded his father as 11th baronet. In 1905 Sir Arthur Nicolson was sent as ambassador to Russia, where he remained until 1910, and in the latter year returned to the Foreign Office, being until 1916, when he retired, permanent Under-secretary for Foreign Affairs. He received the K.C.I.E. in 1888, the K.C.B. in 1901, the G.C.V.O. in 1905, and the G.C.M.G. in 1906. He was raised to the peerage on his retirement, and took the title of Baron Carnock. He published in 1873 a *History of the German Constitution*.

**CAROLUS-DURAN** [CHARLES AUGUSTE EMILE DURAND] (1837-1917), French painter (*see* 5, 381\*), died in Paris Feb. 18 1917.

**CARPATHIANS, BATTLES OF THE, 1915.**—In Jan. 1915 the E. flank of the continuous battle-front in the Carpathians lay around Baligród. Farther to the E. as far as the Rumanian frontier, the Austro-Hungarian High Command had so far succeeded in preventing any Russian penetration into Hungary by means of measures improvised to meet the immediate perils such as the use of Landsturm and volunteers. All these means, however, no longer sufficed.

although the concealment of the concentration, which had to be carried out by means of a railway system of low efficiency, needed the utmost care and precaution. General Brusilov, at all events, spoke of the "whole position" being in jeopardy, in an order issued after the Austro-German offensive opened on Jan. 23.

West of the Czerechna road 4 infantry and 2 cavalry divisions of the III. Austrian Army were to pin to their ground 5 Russian infantry and 1 cavalry divisions. On the E. flank Gen. von Boroevič had 11 infantry and 2½ cavalry divisions<sup>1</sup> against 9 Russian infantry and 4 cavalry divisions; Gen. von Linsingen 6 infantry and 2 cavalry divisions<sup>2</sup> against one Russian infantry and 2 Cossack divisions, and Gen. von Pflanzer-Baltin 6 infantry and one cavalry divisions against 2 to 3 Russian infantry divisions Reichswehr and 2 Cossack divisions. The Russian effective strengths were certainly the greater, but the Central Powers hoped despite all difficulties to keep the attack going. They were undeceived; and the battle in the Carpathians actually dragged on for some three and a half months.

After the Austro-Germans had opened their operations with brilliant initial successes, the winter became, as it were, an ally of their adversaries, and so confined the scope of operations that the Russians succeeded in taking timely counter-measures. The temperature fell 13° F. below zero, and as the troops were operating almost entirely in the open, exposed to all the severity of the weather—and that without relief—sickness and frost-bite soon took a heavier toll even than battle casualties, and the divisions had too few men to fill their battle sectors, which in any case were very wide. In view of the extent of the area of attack, the divisions had, almost without exception, to attack in a single

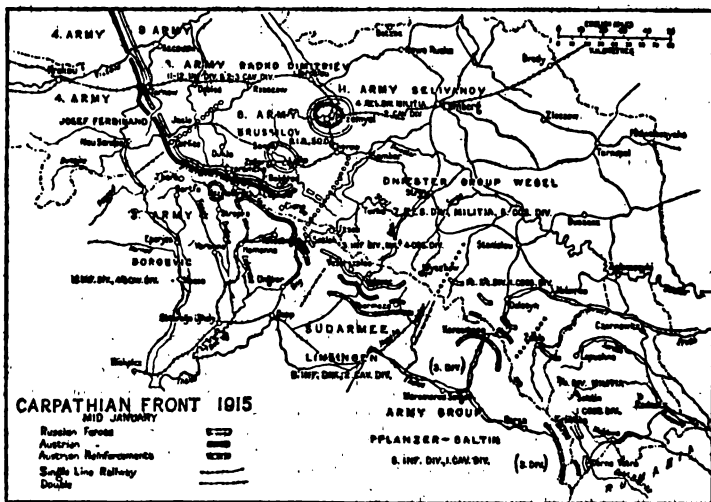

FIG. A.

The security of Hungary and the relief of Przemysl were to be effected by an attack on a broad front across the Carpathians, which, if successful, would develop into a flank attack on a large scale against the whole Russian battle-line. In this operation there were to take part: the army group of Gen. Freiherr von Pflanzer-Baltin, from the Rumanian frontier to E. of Wyszkwów; the German Southern Army, under Gen. von Linsingen (Austrian and German troops); thence to E. of the Ussok pass; the reinforced right wing of the III. Army, under Gen. von Boroevič, thence to the Czerechna road.

Success depended largely on the vulnerability of the blow and on the Russians being surprised. This surprise was in fact secured,

line. After the melting away of their offensive energy no reserves were left for the continuance of the advance; after every action the strength of the troops, tried as they were by adverse circumstances, grew weaker; by Jan. 27 the III. Army was no longer in a position to continue the offensive, and between Feb. 5 and 8 the Southern Army was in the same case. According to the unanimous conviction of both leaders and men the attack had literally "stuck fast in the snow," and thenceforward the battle became a defensive one. The Russians on the 26th had replied

<sup>1</sup> Ten infantry divisions, 2 infantry brigades, 2 cavalry divisions and one Landsturm Hussar brigade.

<sup>2</sup> Five infantry divisions, 2 infantry brigades, 2 cavalry divisions.

\* These figures indicate the volume and page number of the previous article.

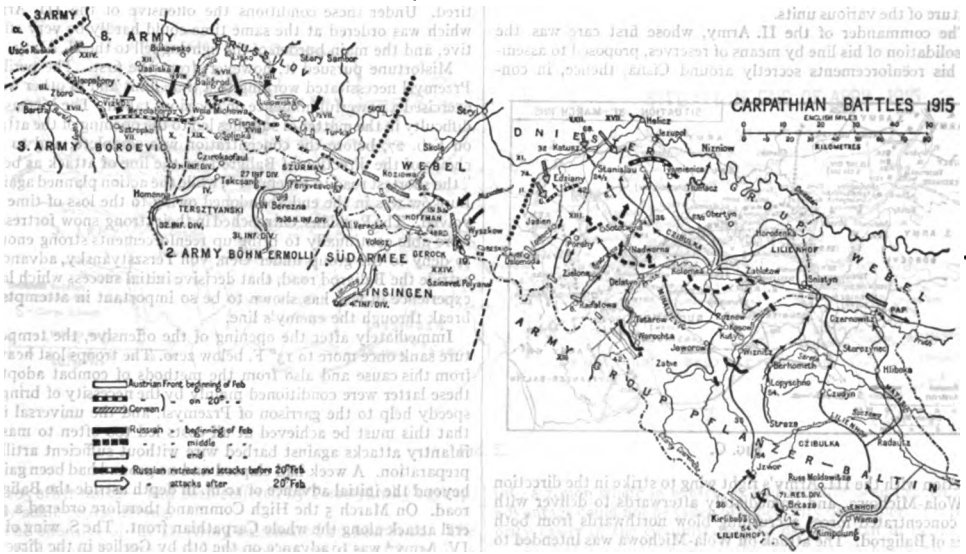

FIG. B.

by a counter-offensive W. of the Mezölaborcz railway, and from the 28th onwards this spread eastwards.

The Southern Army managed to hold its hard-won gains; the III. Army E. of Wola-Michowa still contrived to defend Hungary in Galicia behind the Upper San and on the hills N. and W. of Cisna; but the pressure of hostile masses (some 100,000 strong) astride the Mezölaborcz railway and in the Dukla valley forced it back towards the Hungarian plains to the line Wola-Michowa, Stropko, upper course of the Ondava.

The arrival on the 8th of the XVII. Corps from the IV. Army and the VIII. from the Serbian theatre brought some relief. The XVII. Corps came into line W. of the VII.; of the VIII., the one division (the 21st Landwehr) was sent to the X. Corps, the other (the 9th) to the XIX. and XVIII. Corps which were most in need of assistance. After the arrival of these fresh forces, Gen. von Borojevič commenced on Feb. 10 an attempt to recover the lost ground at Mezölaborcz. This did not prosper, as the Russians here and in the Dukla valley, strongly reinforced, poured ever-fresh masses into the attack. The position of the III. Army grew daily more serious.

Meanwhile Gen. von Pflanzer-Baltin's army group succeeded, in a series of continuous actions from Jan. 31 to Feb. 20, in bearing its standards victoriously through the Bukovina and S.E. Galicia as far as Stanislaw. Its Eastern group (three divisions) had liberated the Bukovina and then moved by way of Kolomea to the N.W. in order to join the Western group (three divisions) which had advanced along the Marmarosziget-Kolomea railway and north-westwards to Nadworna. The Russians, despite their violent counter-attacks, had by the 17th been defeated at Kolomea and their group, fighting stubbornly at Nadworna, was compelled by the increasing pressure on its flank to fall back towards Stanislaw on the 19th. This town was occupied on the 20th by the main body of Pflanzer-Baltin's command, which had been reinforced on the 17th by two cavalry divisions; meanwhile the left wing on the Lomnica wheeled in towards Dolina in order from the rear to open up for the Southern Army the issue from the mountains. Already, however, the concentration N. and W. of Stanislaw of powerful Russian forces—the leading troops of Lechitski's IX. Army—made it evident that the Russians were here preparing a counter-offensive. The

well-developed railway system in Galicia facilitated the rapid reinforcement of the Russian eastern wing. With this the Austrian higher command was unable to compete successfully, for on the mountain railway by Marmarosziget only three divisions (5th from the I. Army, XI. Corps from the III. Army) could be brought up by the early days of March.

It was this circumstance, and the limited time during which the fortress of Przemyśl could hold out, which had meanwhile determined the Austrian higher command, in spite of the experience of winter in the Carpathians, to assemble behind the right wing of the III. Army the forces made available by the weakening of the Russian forces in Poland and the fortifying of positions there, although here none but a frontal attack was possible, and although to the Austrian higher command the offensive of the Pflanzer-Baltin army group seemed to promise the most decisive result. Since, however, a direct support of this group was impossible within the necessary time limit, the plan was to divert by a new attack over the Carpathians, such strong Russian forces as to enable the eastern wing to continue the offensive.

The Southern Army was reinforced by the German 4th Infantry Division. In order to build up the II. Army behind the right wing of the III., from Feb. 6 onward three divisions (27th Inf. Div. and IV. Corps—31st and 32d Inf. Div.) were withdrawn from Poland and the 41st and half the 38th Honved Divisions from West Galicia. On Feb. 15 Gen. von Böhm-Ermolli took over the command of these forces, together with the eastern half of the III. Army (Szurmay's group, consisting of the V., XVIII. and XIX. Corps) which numbered 60,700 rifles.

The left wing of the II. Army as now constituted was fighting with its last reserves of strength. The troops were exhausted almost to the point of collapse by continuous fighting and the severities of the weather. The Russian divisions, on the other hand, were in a better position in that they could usually allow two regiments to rest while two others attacked. It was only owing to the most strenuous exertions that the Austro-Hungarian troops succeeded, without reliefs, in holding the crests and preventing the successive waves of the Russian assault from sweeping away the thin line of defence. Again and again reserves drawn from the front itself came to the support of the points most in danger, a process which exhausted the strength of the

troops, who never had any rest, and led to a lamentable intermixture of the various units.

The commander of the II. Army, whose first care was the consolidation of his line by means of reserves, proposed to assemble his reinforcements secretly around Cisna, thence, in con-



FIG. C.

junction with the III. Army's right wing to strike in the direction of Wola-Michowa, and immediately afterwards to deliver with his concentrated forces a crushing blow northwards from both sides of Baligród. The attack on Wola-Michowa was intended to recapture Lupków station, the junction of a narrow-gauge railway running behind the front of the II. Army.<sup>1</sup> The recovery of this line would considerably facilitate the supplying of that army, the bulk of which was dependent on a single practicable road, of which the condition had alarmingly deteriorated owing to the unusually early thaw. Meanwhile it was no longer possible to ignore the urgent need of support for the W. wing of the army. On Feb. 26 the 16,000 men of the XIX. Corps on this flank were faced by 28,000 Russians, and a division had to be brought into line on the 20th, and another on the 23rd.<sup>2</sup> Not only was the opportunity of surprising the enemy lost, but they were allowed still further time to take counter-measures by the postponement of the Austrian attack on account of the condition of the roads.

The critical position of Przemysl and the continuing concentration of the IX. Russian Army facing the Austrian E. flank induced the Austrian high command to press for an immediate offensive. The Russians had also detached troops from the IX. Army (II. Cav. Corps and 11th Div.) to strengthen Lechitski's army, and the transference thither of other forces from the Nida front (XVII. Corps, 3rd and 35th Divs.) was also probable. In view of the disposition of the railways the only possible method of assisting Pflanzer-Baltin's army group was for the II. Army to attract to its own sector, by means of an early attack, as many hostile troops as possible. This course would considerably increase the difficulties of the II. Army, the special task of which was the relief of Przemysl; but its considerable numerical superiority over its enemies seemed to the Central Powers to afford a prospect of success. South of the Vistula there stood 30½ Russian divisions (exclusive of those investing Przemysl) as against 49 Austrian and German divisions; though many of the Austrian divisions had, it is true, been reduced to little more than the strength of infantry regiments. Every attempt was made to assemble superior forces in the decisive sector, from the Dukla pass to E. of Cisna. In the first few days of March, 17 divisions could be opposed to 7 or 8 Russian divisions, if the reinforcements sent to the II. Army were utilized on the W. wing. In addition, one division from the IV. and one from the I. Army<sup>3</sup> were used here, bringing up the total of fresh divi-

sions to six and a half. The remainder were in many cases dead tired. Under these conditions the offensive of the III. Army which was ordered at the same time could hardly be very effective, and the main burden of the fighting fell to the II. Army.

Misfortune pursued it, however, from the first. The peril of Przemysl necessitated working to a time limit and in other ways exercised a powerful influence on decisions taken. The increasing difficulty in the matter of supplies led to the opening of the attack on Feb. 27, before the concentration was complete, and to the choice of the direction of Baligród for the line of attack as being "the shortest road to Przemysl"; while the action planned against Lupków was in the end abandoned owing to the loss of time involved. The Russians, entrenched in their strong snow fortresses, were able continually to bring up reinforcements strong enough to deny to the group under Gen. von Tersztyánsky, advancing astride the Baligród road, that decisive initial success which later experience in war has shown to be so important in attempts to break through the enemy's line.

Immediately after the opening of the offensive, the temperature sank once more to 13° F. below zero. The troops lost heavily from this cause and also from the methods of combat adopted; these latter were conditioned mainly by the necessity of bringing speedy help to the garrison of Przemysl, and the universal idea that this must be achieved at all costs led too often to massed infantry attacks against barbed wire without sufficient artillery preparation. A week had elapsed and no ground had been gained beyond the initial advance of 10 m. In depth astride the Baligród road. On March 5 the High Command therefore ordered a general attack along the whole Carpathian front. The S. wing of the IV. Army<sup>4</sup> was to advance on the 6th by Gorlice in the direction Jasło-Zmigrod. This had already been recognized by the Austrian higher command as the weakest spot in the Russian line, but even now it had not sufficient forces available to enable it to make full use of this knowledge. The attack was delayed till the 8th, and succeeded in pinning the Russian forces to their ground; parts of von Woyrsch's army detachment and the IX. German Army attacked N. of the Vistula with the same object between March 6 and 9.

During the next few days the III. and Southern Armies carried out no important operations. The II. Army attacked with all its forces along the whole of its front, between March 5 and 10. In spite of this the Russians, by the 10th, had succeeded in bringing into action forces equal to those of their assailants; they were able—with the advantage of strong mountain positions—to oppose to the 112,000 rifles of the II. Army about the same number. On the decisive W. wing they had from 27,000 to 28,000 fresh rifles in reserve as against 13,000 fresh Austrian rifles.<sup>5</sup> This was decisive, for the II. Army was by now



FIG. D.

completely exhausted. Its losses between March 1 and 15 amounted to 51,000 men (over a third of its total strength on March 1).<sup>6</sup> Two-thirds of these casualties—855 officers and

<sup>1</sup> Lt.-Field-Marshal von Arz's group.

<sup>2</sup> 14th Div.

<sup>3</sup> Total strength on March 1, inclusive of divisions still en route: 148,850.

<sup>1</sup> From E. to W., V., XVIII. and XIX. Corps and later IV. Corps.

<sup>2</sup> 41st Honved Div. on Feb. 20; 27th Div. on the 23rd.

<sup>3</sup> 13th Landwehr and 14th Divs. respectively.



FIG. E.

37,205 other ranks<sup>1</sup>—had been suffered by Terzstyánsky's group, only some 70,000 strong.

The offensive of the II. Army culminated on March 10. The Russian counter-offensive,<sup>2</sup> commencing on the 11th with a flank attack by Wola-Michowa, checked the attack astride the Baligrod road, and on the 14th it had to be abandoned as hopeless.

The offensive wedge of the II. Army had acted as a magnet to some 51 Russian divisions. Among these were the 35th and 3rd Divs. so that the object of relieving the pressure on Pflanzer-Baltin's front had been achieved.

General Lechitski had commenced his offensive against this group with four corps on Feb. 28, and the Austrian right wing, outnumbered, had fallen back, fighting stubbornly, to N. of Obertyn. Thanks to the timely arrival on March 4 of the XI. Corps from the IV. Army, Pflanzer-Baltin's troops succeeded in holding their new front, although the Russians had by the 10th advanced in N. Bukovina as far as the Pruth. On March 18 their offensive against the Austrian E. wing came to a standstill.

The relief of Przemysl had thus proved impossible. However, in order to assist the garrison in its attempt to cut its way out, by holding fast as many Russian troops as possible, a striking force was assembled, despite all obstacles, on the E. wing of the II. Army. There could be however no question of cooperating with the garrison, as the *sorite* attempted on the 19th broke down while still within the fortress area, all stocks of food being exhausted; a capitulation was signed on the 22nd after all war material had been as far as possible destroyed.

The failure of the attempts to relieve Przemysl much discouraged the Austrian troops, particularly those of the II. Army. Their endurance and self-sacrifice, however, were not entirely in vain. The attention of the Grand Duke Nicholas had been so riveted on the danger threatening him to the S. of Przemysl that he lost sight of the duty of cooperating with the Western Allies of Russia, and decided to attempt a break-through into Hungary with the forces now assembled to the S. of Przemysl. This was quite in accordance with the wishes of the Austrian and German high commands, which up to that time had sought to defend Germany by continuous attacks in the Carpathians. The strong Russian forces now directed against Hungary were being enticed

into a region where in winter, as had recently been proved, full advantage could not be taken of superiority of numbers, a superiority easier in the circumstances to destroy than to maintain.

The last great attempt of the Russians to break through began on March 20 with an onslaught of unexampled violence against the whole front of the III. Army, which, despite all it could do, was gradually forced farther back in the direction of Hungary. Units of the IV. Army<sup>3</sup> arriving on the 28th to reinforce the left wing brought the attackers to a stand; but against the centre and right of the army the Russians continued their attacks with ever-fresh forces, and it was obvious that their object was to break through towards Varanno and Homonna, the most northerly points of the Hungarian plain. This caused the utmost anxiety to the II. Army command. As early as the 23rd a gap existed between the left flank of that army and the retreating right of the III., and although, itself heavily pressed, the II. Army had no option but to put in some march battalions<sup>4</sup> to fill it. Again on the 26th, at a time when its own front was weakening rapidly, the army dispatched a combined brigade<sup>5</sup> from its W. wing, and one infantry<sup>6</sup> and one cavalry brigade<sup>7</sup> from its E. wing to the III. Army. (The infantry were sent back later.) Any further successes against the right of the III. Army must have seriously menaced the position of the II. Army stationed N. of the frontier ridge. On the 27th, accordingly, the army command proposed a voluntary withdrawal; but the high command, which throughout these days of dire peril still held firmly to its offensive projects, refused its assent, as the blocking of the Laborca valley by the German Beskiden Corps<sup>8</sup> (4th German Div. of the Southern Army, 25th Res. Div. of the IX. Army, 35th Res. Div. of Woysrsh's group) had begun.

Meantime, however, the Russians at the end of March had driven the II. Army to retreat. The system of constantly patching the front with troops withdrawn from other sectors was no longer possible, in view of the fact that the enemy's attacks were now simultaneous all along the army line. The lack of good roads prevented these reserves arriving in time or in sufficient numbers to gain isolated successes. The Russians, being superior in numbers, were able to seize the opportunity afforded by the withdrawal of reserves from the centre of the II. Army at Cisna to drive in its front in that sector. Here they seriously menaced

Killed and wounded . . . . .	340 officers	17,210 other ranks
Sick . . . . .	415 "	11,098 " "
Prisoners . . . . .	31 "	1,194 " "
Missing . . . . .	33 "	7,793 " "
Total . . . . .	855 officers	37,205 other ranks

i.e. 54% of the total strength.

<sup>2</sup> 25,000 Russians against 17,400 rifles of the XIX. Corps.

<sup>3</sup> Parts of the 26th Landwehr and 8th Div.  
<sup>4</sup> Col. Biff's combined brigade.  
<sup>5</sup> Lt.-Field-Marshal Martiny's combined brigade.  
<sup>6</sup> 128th Honved Brigade.  
<sup>7</sup> 1st Landsturm Hussar Brigade.  
<sup>8</sup> Beskiden, i.e. the range of the Carpathians separating East Galicia from Hungary.



the single practicable road, by which alone a deliberate withdrawal could be carried out by the Austrians. The situation being now critical, the II. Army command on April 1 gave the order for a retreat. The sorely tried II. Army had to fall back in one bound between April 2 and 4 to the line Patakofalu-Nagypolany-N. of Vizava, to the S. of the Carpathian ridge; only Saurmay's group, detached to the Southern Army, was to hold the Uzsook pass on the crest itself.

The effect of this surrender of the main ridge was not only to shorten the Austrian front, but also to utilize the mountains, hitherto an impediment to their operations, as an obstacle against the Russians and improve the internal situation of the II. Army (practicable roads and billeting facilities right up close behind the front). The Russians did not molest the withdrawal; indeed when it began they were endeavouring with the forces set free by the fall of Przemysl to break through in the Laborceza valley. The attack fell on the battered X. Corps, which was slowly pressed back; the gate of Hungary seemed on the point of being forced. Fortunately for the Central Powers, the German Beskidien Corps arrived just at the right moment to close it again in concert with the X. Corps, in the "Easter battle" (March 2 to 5). While the II. Army was falling back over the frontier ridge on the 3rd, the pressure in the Laborceza valley was checked; on the 4th the Russians lost ground, and by the 5th the situation had been restored.

The Grand Duke now extended his attack on both flanks, but in vain. The III. Army repulsed all the mass attacks of the enemy, and by April 9 the great battle on its front, which had continued without interruption since March 20, came to an end. On the II. Army front the Russians suffered considerably from cold and hardship in the inhospitable mountain country and were compelled to halt to reorganize their lines of communication, so that they could only follow up the II. Army slowly, and had to leave much of their artillery behind. The II. Army was therefore allowed time to dig itself in and bring up enough troops to hold its chosen line of resistance. Better weather (sunny days, and night temperatures of only 23°F.) did much to improve the condition of the troops.

As the roads became better, the main weight of the Russian attack was transferred to the left wing (astride the Telepocz road near that place). This, the last serious offensive against the II. Army front, was finally repulsed on the 13th after a fresh division<sup>1</sup> from the IV. Army had been put into line. Despite the most desperate efforts, the Russians failed during the following days to secure any further success. Their last gain of ground was the capture of the hotly contested height of Kozialata on the 17th; a series of unsuccessful Austrian counter-strokes prolonged the fighting till the 20th, when the consolidation of the opposing fronts and the mutual exhaustion of the combatants ended it.

Only on the E. wing of the army, which had cooperated with Saurmay's hard-pressed troops of the Southern Army at the beginning of April in the defence of the Uzsook pass, was there still considerable activity. The Russians repeatedly assailed the pass and the Upper Ung valley from N.W., N. and N.E., between April 21 and 26, but were held off by the united efforts of Saurmay's group and the E. wing of the II. Army. The railway, which had only been repaired after great difficulty, remained available for use during the spring offensive.

Elsewhere the Southern Army front remained on the whole unchanged. After some weeks of sapping the hotly contested Zwinin ridge was stormed on the 9th, and the Ostry on the 25th by the Stryj detachment (detached E. wing of Brussilov's army, 4th Div.). Pflanzer-Baltin's group, reinforced in March by three cavalry divisions, also held its old positions in Galicia; it had once more driven the Russians from the northern Bukovina although the IX. Army in its front had been increased to 8 infantry and 9½ cavalry divisions, and 7 reserve brigades.

The character of the battle in the Carpathians, which stemmed the Russian advance southwards, is shown by the figures given in tabular form in the following statement, which was issued by the Austrian high command on April 20.

<sup>1</sup> The 51st Hooved Div.

Army.	Frontage.	Rifle Strength (incl. cavalry).
German X. Army	85 miles	79,000 against 180,000 Russians <sup>2</sup>
" VIII.	96 "	45,000 " 124,000 "
Gallwitz' Army	92 "	130,000 " 304,000 "
German IX. Army	72 "	104,000 " 196,000 "
Woyrsch's Army	44 "	84,000 " 50,000 "
Austrian I. Army	48 "	57,000 " 50,000 "
" IV.	72 "	108,000 " 100,000 "
" III.	48 "	116,000 " 106,000 "
" II.	38 "	90,000 " 115,000 "
Southern Army	63 "	85,000 " 120,000 "
Pflanzer-Baltin's Group	92 "	100,000 " 155,000 "
Total . . .	720 miles	1,001,000 against 1,540,000 Russians

The positive objective twice attempted by the Central Powers, the relief of Przemysl, was not achieved. Their negative aims were, however, successfully accomplished; the Russians were prevented from attacking Germany, and their attempted invasion of Hungary was also frustrated. Finally the gradual melting away of the best elements of the old Imperial Russian Army was one prominent cause of the great successes of the Central Powers during the spring offensive. (K. M.)

**CARPENTER, WILLIAM BOYD** (1841-1918), English divine, was born at Liverpool March 26 1841, the son of the Rev. Henry Carpenter, incumbent of St. Michael's, Liverpool. He was educated at the Royal Institution school, Liverpool, and at St. Catherine's College, Cambridge, where he graduated in 1864, being ordained the same year. He earned a great reputation as an eloquent preacher, and in 1882 became a canon residentiary of Windsor, two years later being made bishop of Ripon. He resigned his see in 1911, and was made canon and later sub-dean of Westminster. He died in London Oct. 26 1918.

**CARR, JOSEPH WILLIAM COMYNS** (1849-1916), English art critic and dramatist, was born in London March 1 1849, his father being a member of an old Cumberland yeoman family. Educated at the university of London, he was called to the bar in 1869, but soon became a writer of art criticism for the *Pall Mall Gazette* and, after 1875, editor of *L'Art*. He also founded and edited the *English Illustrated Magazine*, and was associated with Charles Hallé in the founding of the New Gallery, an offshoot from the Grosvenor Gallery, in 1888. In his later years he engaged in theatrical enterprises, and he was the adapter, alone or in collaboration, of a good many plays, notably Hardy's *Far from the Madding Crowd* (1882) and the version of *King Arthur* produced by Sir Henry Irving at the Lyceum theatre in 1895. He published *Some Eminent Victorians* (1908) and *Coasting Bohemia* (1914), both containing reminiscences of his own early life and the people he had known. He died in London Dec. 12 1916.

See *J. Comyns Carr: Stray Memories*, by his wife (1920).

**CARRANZA, VENUSTIANO** (1859-1920), Mexican revolutionary and president, was born Dec. 29 1859, at Cuatro Ciénegas, Coahuila. He was educated in the Ateneo Fuentes at Saltillo and in the Escuela Nacional Preparatoria at Mexico City. Defective eyesight prevented a legal career for which he had studied. Entering politics, he became *presidente municipal* of Cuatro Ciénegas in 1887. In 1893 he and his brother Emilio led a revolt against the repeated candidacy of García Galán for the state governorship, and they succeeded in inducing President Díaz to name General Muzequiz as governor. Carranza was first elected senator *suplente* (alternate) for Coahuila for 1900-2. On the death of the proprietary Ortiz de Montellanos, he took his seat April 5 1901. He was elected proprietary senator for 1904-8, and again for 1908-12, but served only until Dec. 15 1910. In the position of senator he was amenable to the control of Díaz. In 1909 he became candidate for the state governorship in opposition to the wishes of the central Government. In the following year he joined the Madero revolution, serving as a member of the Junta Revolucionaria at San Antonio, Texas. Madero made

<sup>2</sup> Infantry divisions reckoned as being 14,000 rifles, cavalry divisions as 2,000 sabres.

<sup>3</sup> Including Austrian reinforcements arrived since April 15.

him chief of the military division of Coahuila, Nuevo León, and Tamaulipas and later Minister of War in his provisional Cabinet. In this position he organized Madero's army. After the triumph of the revolution he returned to Coahuila and assumed the governorship, to which he was regularly elected in May 1911. After the *coup* of General Huerta, Feb. 18 1913, and the murder of Madero, to whom he was attached, Carranza issued the Plan de Guadalupe in March, disavowing Huerta as president. He then became First Chief of the Constitutionalist army and personally visited all northern Mexico to organize the opposition, establishing his government at Hermosillo, Sonora, whence he moved southward until he entered Mexico City Aug. 20 1914, after Huerta had fled. He was opposed by Francisco Villa and Emiliano Zapata after the split of the Constitutionalist, and withdrew to Vera Cruz, which he occupied when the American occupation terminated. On Oct. 9 1915, he was recognized as head of the *de facto* Government by the United States and seven Pan-American powers. On Sept. 30 1916 he decreed the abolition of the vice-presidency and the limitation of the presidential term to four years instead of six. He was elected to the presidency March 11 1917, under the constitution promulgated under his sanction on Feb. 5. Under this radical body of fundamental law he issued a series of decrees for the nationalization of petroleum lands, which kept his Government continually in strained relations with England, France and the United States. As the time approached in 1920 for the election of his successor, he attempted to force the election of Ignacio Bonillas, a civilian candidate. This led to an attempt to control the state government of Sonora, a stronghold of Alvaro Obregón, who was the strongest and most popular aspirant for the presidency, but who was inimical to Carranza's politics. The state revolted in March 1920, being immediately followed by the country at large. Carranza attempted to move his Government to Vera Cruz on May 7. His flight was interrupted and he himself was killed as he was fleeing the country, on the night of May 18, at Tlaxcalantongo, Puebla.

**CARRÉL, ALEXIS** (1873- ), Franco-American surgeon, was born at Sainte-Foy-les-Lyon, France, June 28 1873. He graduated at the university of Lyons (L.B., 1890; Sc.B., 1891; M.D., 1900), and for two years was *professeur à la faculté de médecine* at that university. In 1909 he became a member of the Rockefeller Institute for Medical Research in New York. There he won world-wide fame by his experiments in transplanting human organs. In 1912 he read before the American Medical Association a paper on *Preservation of Tissues and its Application to Surgery*. The possibility of keeping alive tissues removed from the organism led to his seeking practical means of preserving them for surgical use. He was awarded a Nobel prize in 1912 for his contributions to surgical knowledge. On the outbreak of the World War he returned to France and devised the Carrel-Dakin treatment of wounds. Using H. D. Dakin's preparation, a neutral solution of hypochlorite of sodium, Carrel's apparatus keeps the wound continually moist. Countless amputations were avoided, healing was rapid, and scars supple. In 1919 he resumed his work at the Rockefeller Institute.

**CARSON, EDWARD HENRY CARSON, BARON** (1854- ), British statesman and lawyer, son of Edward Henry Carson, C.E., Dublin, was born Feb. 9 1854 and educated at Portarlington school and afterwards at Trinity College, Dublin. He was called to the Irish bar, and made his reputation as Crown Prosecutor in Dublin in the difficult years when Mr. Balfour was Chief Secretary for Ireland. His pluck, readiness, wit, and skill in cross-examination soon brought him to the front both in legal and in political circles. He became a Q.C. at the Irish bar in 1889; but his ambitions could not be satisfied with legal eminence in Dublin. He was called to the English bar, and took silk there in 1894. Meanwhile he had been returned to Parliament in 1892 in the Unionist interest as member for his own university of Dublin and was for a few months Solicitor-General for Ireland. He entered Parliament just when Gladstone was about to make a second effort to pass a Home Rule bill, and he helped the Unionist leaders to defeat the measure. But during the next 20 years he

was mainly occupied with his professional work. Having risen to a leading place at the bar in Ireland, he achieved an even more striking success at the English bar; and in 1900 he was appointed Solicitor-General, a post which he held until the change of government in 1905-6. In the early years of the new century he gradually came to be regarded as the spokesman in the House of Commons of the Irish Unionists, and in that capacity welcomed Mr. Birrell's University bill of 1908.

It was not until 1911, when another Home Rule bill was imminent, that Sir Edward Carson emerged as a political figure of first-class importance. He bitterly resisted the Parliament bill, which was to curtail the power of the Lords and enable a measure of Home Rule to be passed over their heads and without a direct appeal to the people. He was one of the "Die-hards" who urged the peers to take the responsibility of throwing out the bill in spite of the ministerial threat to swamp their House with sufficient new creations to make its passage secure. He told the House of Commons that the passing of Home Rule by force would be resisted by force and that the resisters would be constitutionally right. Feeling against the bill was most bitter in Ulster, which, Protestant and loyal, would be placed by it at the mercy of the Roman Catholic and largely disloyal majority of the other three provinces. He went to Ulster in the autumn, and at an enormous Unionist demonstration at Graigavon, near Belfast, endorsed the threats of rebellion against Home Rule which previous speakers made. Belfast, he said, was the key of the situation; Ulster would never submit to a Parliament in Dublin. They must be prepared, if necessary, to take over the administration of those districts which they were entitled to control. Practical measures were immediately undertaken in this direction, though Liberals and Nationalists scoffed. His position was that, he and his Ulster friends were loyal to the constitution as it existed; they were only rebels, he said, in the sense that they desired to remain under the King and the imperial Parliament. In anticipation of the introduction of the Home Rule bill in the spring of 1912, he presided over a gigantic gathering in Belfast in Easter week, which Mr. Bonar Law, the newly appointed Unionist leader, came to address; and he made those present repeat after him, "We will never, in any circumstances, submit to Home Rule." He himself, in a speech instinct with passion, moved the rejection of the bill on its introduction, and took a leading part in opposition during its subsequent stages. But his activity was mainly outside. He made frequent speeches in the next couple of years in different parts of England and Scotland, particularly at a great demonstration at Blenheim in July 1912, at which Mr. Bonar Law pledged the support of the Unionist party to Ulster. But his principal work was in the organization of resistance in Ulster itself, including the formation of a local volunteer force, which speedily assumed large proportions. In Sept. 1912 he was the chief figure at a series of demonstrations in all parts of the province, culminating in an enormous assemblage at Belfast on Sept. 28. There he took the lead in signing a solemn covenant by which the men of Ulster bound themselves to stand by one another in defending their position of equal citizenship in the United Kingdom, and in using all necessary means to defeat the conspiracy to set up Home Rule, and further pledged themselves to refuse to recognize a Home Rule parliament. He followed this up by moving unsuccessfully in Parliament on New Year's day 1913, to exclude Ulster from the operation of the bill. In the autumn of 1913 the Ulster Unionist Council organized itself, under his supervision, into a provisional Government, of which he was the leading member, and a guarantee fund of £1,000,000 was initiated to which he himself contributed £10,000. He reviewed the volunteers, who were rapidly becoming a formidable military force approaching in number 100,000 men. But when ministers, who had refused to prosecute him or interfere with his activities, began to realize the determination of the six north-eastern Protestant counties, he did not repulse their overtures for a settlement by consent, but said that it must not establish a basis for separation. His advice during the following winter to his Ulster friends was "peace but preparation." He entirely declined to accept Mr. Asquith's offer, in the spring

of 1914, of a county option of exclusion for six years. That was "sentence of death with a stay of execution." If that was the Prime Minister's last word, his place was in Belfast; and he and several of his fellow Unionist members from north-east Ireland made a dramatic exit from the House on March 19 to go to Ulster. When he returned for the debates on the Curragh incident he told the House that there was only one policy possible, "Leave Ulster out until you have won her consent to come in." He became a member of the abortive Buckingham Palace Conference convened by the King in the hope of compromise; and when that broke down in the end of July it looked as if he and his Ulster friends would have to make good in action their policy of force.

The World War supervened, and switched off his activity into another direction. Though he resented, as a breach of the political truce between parties, Mr. Asquith's determination to pass the Home Rule bill into law while suspending its operation and promising some form of special treatment for Ulster, he went to Belfast in order to stimulate Ulstermen and especially Ulster volunteers to join the British army, and had a considerable success. He was eager for a thorough prosecution of the war, and accordingly joined Mr. Asquith's Coalition Ministry of June 1915 as Attorney-General, resigning however in Oct. because he thought that the policy of the Cabinet, after the defection of Greece, involved the desertion of Serbia, a small country in whose fate he took a profound interest. He was strongly in favour of the Compulsory Service bill in 1916, and regretted that Mr. Redmond should insist on excepting Ireland from its provisions. He looked favourably upon Mr. Lloyd George's efforts that summer to arrange an agreed settlement of the Irish question, and when that statesman formed a new government in Dec. for the more efficient conduct of the war, joined his Cabinet as First Lord of the Admiralty. The great anxiety of the Board of Admiralty at this period was how to counter the German submarine attack which was steadily increasing in intensity. He placed his reliance mainly on an Anti-Submarine Department which had been established in Whitehall, consisting of the most experienced men serving at sea, and on the Board of Inventions, under Lord Fisher, with whom were associated some of the greatest men of science in the country. His shipbuilding programme was largely one for making good losses in the mercantile marine. The losses however continued to increase, and led to a reorganization of the Admiralty, with a view to strengthening the navy war staff as well as to put the supply on a sounder basis by revising the office of Admiralty Controller. Outside his departmental duties Sir E. Carson warmly promoted the Irish Convention which the Government assembled this year. In July he quitted the Admiralty to become a member of the War Cabinet without portfolio, a position which he resigned at the beginning of 1918. But, in or out of the office, his activity was directed wholeheartedly to the vigorous prosecution of hostilities.

After the war was over, Ulster and Ireland regained the first place in his thoughts. At the general election of 1918 he left Dublin University, in order to represent one of the divisions of Ulster's capital, Belfast. On the anniversary in July 1919 of the battle of the Boyne, he restated, speaking near Belfast, Ulster's position and claims, demanded the repeal of the Home Rule Act, threatened to call out the volunteers if any attempt were made to change Ulster's status, declared Dominion Home Rule to be merely a blind for an Irish Republic, and criticized Sir Horace Plunkett as one who was distrusted by both sides. When, however, Mr. Lloyd George proposed in the winter his bill for the reform of the government of Ireland, establishing parliaments and executives both in Dublin and in Belfast, and a Federal Council for all Ireland, he moderated his attitude. Though he would have preferred that Ulster should remain in the United Kingdom, yet, as this bill gave her a parliament of her own, he would not oppose it. When the bill left the Commons in Nov. 1920, he said that, though Ulster did not ask for a parliament, she would do her best to make the arrangement a success. He exerted himself to that end in Ireland, with the result that the Unionists succeeded even beyond their hopes in the elections

in May 1921 for the first Ulster Parliament, and so started with an overwhelming majority. But he declined to sit in the new parliament himself; and he also resisted the suggestions that he, as the most outstanding fighter in the Unionist party, should be put forward to succeed Mr. Bonar Law as leader in the British House of Commons. He had done his best to save Protestant Ulster from domination by the Roman Catholic majority of the south and west. He was 67 and had felt the strain of the last 10 years; so he quitted active politics, and accepted a lordship of Appeal and a life peerage as Baron Carson of Duncairn.

He was twice married—in 1879 to Sarah A. F. Kirwan, who died in 1913, leaving two sons and a daughter; and in 1914 to Ruby Frewen, by whom he had one son. (G. E. B.)

**CARTWRIGHT, SIR RICHARD JOHN** (1835-1912), Canadian statesman (see 5435), died at Kingston, Ont., Sept. 23 1912.

**CARUSO, ENRICO** (1857-1921), operatic tenor, was born in Naples, Feb. 25 1873. He was early apprenticed to a mechanical engineer. He began to sing in the choirs at Naples when he was 11, and later studied for three years under Guglielmo Vergine. He made his debut in 1894 in *L'Amico Francesco* at the Teatro Nuovo, Naples. He first won marked success as Marcello in *La Bohème*, at Milan, in 1898; and at La Scala theatre in that city, he sang for the next four years. From 1899 to 1903 he was at St. Petersburg in the winter, and in the summer at Buenos Aires. But meanwhile he appeared also in many cities, including Moscow, Warsaw, Rome, Paris and London (Covent Garden 1902), everywhere being warmly greeted. In America he first appeared in 1903 at the Metropolitan Opera House, New York, where for 18 years he was the leading tenor. He made an extensive concert tour through the United States in 1917. He had a very extensive Italian and French repertory, but never essayed Wagnerian rôles. He won special success in *Aida*, *Carmen*, *Huguenots*, *L'Elisir d'Amore*, *Pagliacci*, *Rigoletto* and *Somson*. He died Aug. 2 1921 at Naples.

**CARY, ANNIE LOUISE** (1842-1921), American singer (see 5438), died April 3 1921 at Norwalk, Conn.

**CASEMENT, ROGER DAVID** (1864-1916), British consular official and Irish traitor, was born near Dublin Sept. 1 1864. His family were Protestants who migrated to Ulster from the Isle of Man early in the 18th century, and he was brought up in the Protestant faith. Early in his career he was in the service of the Niger Coast Protectorate, afterwards entering the British consular service, and being appointed to Lorenzo Marques (1895), Loanda (1898) and to the Congo Free State (1898). After seven years on the Congo he was transferred to South America, going to Santos (1906), to Pará (1907) and to Rio de Janeiro as consul-general (1908). In 1910, charges of cruelty having been brought against the agents of the Anglo-Peruvian Amazon Co., operating in the region of the Putumayo, a tributary of the Upper Amazon, Casement was commissioned by the British Government to inquire into these charges on the spot. The result of his investigations was published as a Blue Book in 1912, and public opinion was deeply shocked by the evidence it contained of the appalling atrocities committed on the natives employed in collecting rubber (see PUTUMAYO). For this service he was knighted. His mind, however, seems to have become affected as the result of his experiences in the tropics, and on his return to Ireland from South America he developed a fanatical hatred of England, throwing himself with ardour into the movement for Irish independence.

As early as Jan. 1913 *Irish Freedom*, a Sinn Féin monthly review, had foretold the coming war with Germany and proclaimed this as "Ireland's opportunity," and to the July number of this review Casement, under the pseudonym of San Van Vocht, contributed an article on "Germany, Ireland, and the next War," in which he elaborated this theme. From the first he took an active part in the Volunteer movement in the south, and when, in the spring of 1914, the bulk of the Volunteers ranged themselves under Mr. Redmond's leadership (National Volunteers) he attached himself to the Sinn Féin section, which refused all compromise (Irish Volunteers). He had in the previous year made efforts, in concert with Mrs. J. R. Green and Capt. White,

to organise in the north counter-demonstrations of Protestants against the Ulster movement which culminated in the swearing of the Covenant; but these efforts were a complete failure.

After the outbreak of the World War Casement went to the United States, whence he wrote in Oct. urging Irishmen to stop in Ireland, "as they have no quarrel with Germany." In Nov. he went to Berlin and a *communiqué* from the German Foreign Office, published in the official *North-German Gazette*, stated that he had been given assurances there with regard to Ireland in the event of a successful German invasion of Great Britain. A pamphlet by him, entitled *The Crime against Ireland and how the War may right it*, appealing for a German-American-Irish alliance, was disseminated in the United States as part of the German propaganda. In Feb. 1915 he wrote an "open letter" to Sir Edward Grey accusing the British Government of conspiring against his life. During that year he visited the prison camps in Germany and tried, with very poor success, to undermine the loyalty of Irish soldiers who were prisoners of war, making them alluring promises if they would join an Irish brigade to fight for Ireland against Great Britain. He succeeded in keeping in touch with the extreme elements in Ireland and in arranging with them the rebellion planned for Easter week 1916, of which he himself proposed to take the lead. On April 12 he sailed for Ireland in a German submarine, which was accompanied by a vessel, laden with arms and ammunition, and purporting to be the Norwegian s.s. "Auk." They reached the coast of Kerry on the 18th; but the Government was forewarned. The "Auk" was captured by a British patrol boat and sunk by her own crew while being taken to Queenstown. Casement, who with two companions had landed in a collapsible boat at Banna, was arrested on the 24th in a ruined fort which afterwards became a place of pilgrimage for Sinn Féin Irishmen. He had meanwhile succeeded in sending a message to Dublin, announcing the capture of the "Auk" and advising the postponement of the enterprise. This action, which really broke the back of the rebellion, was bitterly denounced by some of his fellow conspirators, who even ascribed their misfortunes to his insane belief in his own superhuman powers.

Immediately after his arrest Casement was taken to London, and on May 15 was charged at Bow Street police court with high treason, and committed for trial. The trial began on June 26 before the Lord Chief Justice and two other judges. On June 29 he was convicted and sentenced to death, and on the following day was degraded from his knighthood. The Court of Criminal Appeal dismissed his appeal against conviction on July 18, and he was executed in Pentonville prison on Aug. 3, having been received into the Roman Catholic Church just before his death.

See L. G. Redmond Howard, *Sir Roger Casement: a Character Sketch without Prejudice* (1916). Also a sketch by McQuilland in *Sunday Herald* (April 30 1916), and the White Paper issued by the British Government, *Documents relating to the Sinn Féin Movement* (Cmd. 1108).

**CASHIN, SIR MICHAEL PATRICK** (1864— ), Newfoundland politician, was born at Cape Broyle, Newfoundland, Sept. 29 1864. He was educated at St. Bonaventure's College, St. John's, and afterwards adopted a business career, becoming a fishery merchant at Cape Broyle in 1885. In 1893 he entered politics as Liberal member for Ferryland, becoming a prominent member of the party. In 1905, however, he broke away from the Liberals, joining first the Independent Liberal party, and later (1908) the People's party led by Sir Edward (afterwards Lord) Morris. He was chosen to represent Newfoundland on the Commission on West Indian Trade held at Jamaica in 1901, and after the outbreak of the World War occupied various important political posts. In 1917 he became Minister of Finance, and as such was largely instrumental in raising the Victory loan, and in 1918 he was successively acting Prime Minister during the absence of Lord Morris, acting Minister of Militia and acting Minister of Shipping. He was in the same year created K.B.E.

**CASSEL, SIR ERNEST JOSEPH** (1852—1921), Anglo-German financier, was born at Cologne March 3 1852. His father, Jacob Casel, was a small banker in that city, and the son at the age of

16 became a clerk in the banking firm of Elspächer, but in 1876 came to London and entered the foreign banking house of Bischoffsheim and Goldsmid. There, before he was 20, he attracted notice by his skilful disentanglement of the accounts of the Kheivialoans. In 1884 he set up for himself and became largely interested in South-American finance. He reorganized the finances of Uruguay, and issued three Mexican loans, as well as acquiring the Royal Swedish railway and financing enterprises such as Vickers' absorption of the Maxim-Nordenförlt Co and the building of the Central London railway. He also raised a Chinese loan after the war with Japan. His principal achievement was, however, the financing of the Nile irrigation work, and in connexion with that, the founding of the National Bank of Egypt. In these schemes he worked hand in hand with Lord Cromer. For these services he received a Privy Councillorship in 1902 and was created K.C.V.O. He had previously been created K.C.M.G. (1896) and he subsequently received the G.C.M.G. (1903), the G.C.V.O. (1906) and the G.C.B. (1909). He was also the recipient of decorations from the Governments of France, Sweden, Turkey and Japan. During the World War, though he had long been a naturalized British subject, an attempt was made to have his name removed from the list at the Privy Council. It did not succeed. He had retired from active financial operations in 1910. His benefactions were extensive, and included £500,000 for educational purposes, £225,000 for a hospital for nervous diseases, £50,000 to King Edward's Hospital Fund in memory of his only child, Mrs. Wilfrid Ashley, who died in 1911, besides large gifts during the war to the British Red Cross. He also built and endowed an Anglo-German Institute in 1911 in memory of King Edward VII., with whom he had been upon terms of close friendship. He was a considerable breeder and owner of race-horses; and he acquired a collection of Early English pictures, including a celebrated Raeburn. He married in 1878 Annette, daughter of R. T. Maxwell. She died in 1881. Sir Ernest died in London Sept. 21 1921.

**CASSEL, GUSTAV** (1866— ), Swedish economist, was born in 1866. After taking his degree in mathematics at the university, he became a lecturer, and was appointed professor of national economy at the High School of Stockholm in 1904. He studied and travelled widely abroad. In addition to a number of books in Swedish, he published the following works in other languages: *Das Recht auf den vollen Arbeitsertrag* (1900); *The Nature and Necessity of Interest* (1903); *Theoretische Sozialökonomie* (1919); *His Memorandum on the World's Monetary Problems*, published by the League of Nations for the International Financial Conference in Brussels in 1920, attracted widespread attention. He was a member of many committees dealing with matters of State in Sweden and devoting much labour to the creation of a better system of budget exposition and control (1905—21). He was one of the Swedish representatives at the International Chamber of Commerce meeting in London in 1921. He became a member of *Swenska Vetenskapsakademien* and correspondent for Sweden to the Royal Economic Society.

**CASTELNAU, EDOUARD DE CURIÈRES DE** (1851— ), French general, third son of the Marquis Michel de Curières de Castelnau, was born at Rouergue on Christmas Eve 1851. He was educated first at the Jesuit college there, and later in Paris, and entered St. Cyr in 1869. When war broke out with Prussia the young cadet was posted to an infantry regiment, and he rose to the rank of temporary captain, being given a permanent commission as lieutenant when peace was made. He was promoted captain in 1876 and commandant in 1889. By 1893 his genius for organization had become apparent; and he was called to Paris by Gen. de Miribel. He remained at the Ministry of War for some six or seven years, during which time he perfected the French system of mobilization. That system remained in 1914 fundamentally the same as it had been conceived by him in 1900. On leaving Paris de Castelnau was promoted colonel. He was later given command of a brigade, and, in 1910, of a division. When Gen. Michel left the post of generalissimo and Joffre was appointed in his stead, Castelnau was designated as his chief-of-staff in case of war. But his religious and political views—the

was nicknamed *le capitain bête*—caused him to be regarded with suspicion, and in consequence he was designated for the command, in case of war, of the II. Army in Lorraine, which command, on the outbreak of hostilities in 1914, he assumed. With Gen. Dubail (I. Army) he was responsible for the operations of Aug. and Sept. 1914 in Lorraine. The first offensive towards the Saar was unsuccessful, but his repulse of Prince Rupprecht's VI. Army on the heights of the Grand Couronné, in Aug. and Sept. 1914, not only saved Nancy but paved the way for the Marne victory. He was made grand officer of the Legion of Honour. In the beginning of the "Race to the Sea" (Sept.-Oct.) the II. Army staff and its leader took command of the forces that were pushed into the region between the Oise and the Somme, and fought a series of encounter battles which ended in the stabilization of the front. In 1915 he took command of the group of four armies which constituted the French Centre, and he was in charge of the French offensive in Champagne in the latter months of the same year. On Dec. 10 1915 he was appointed "major-general of all the armies," with the intention that he should be *ad latus*, and eventual successor of Joffre. But in practice, and partly as the result of political intrigue against him, Castelnau's rôle was reduced to that of occasionally representing the commander-in-chief. It was in this capacity that he went to Salonika in the winter of 1915-6 to inspect the condition of affairs there, and it was in this capacity also that he performed his greatest service to France when, summoned at a moment's notice to Verdun, he found the defence overpowered and disorganized by the suddenness of the German attack. The splendid part he played in steadying and inspiring the historic French resistance cannot easily be exaggerated. After a few days' work he was able to hand over the defence, systematized, reinforced and confident, to Pétain. In Jan. 1917 after the appointment of Nivelle, many years his junior, to the chief command, he was sent on a mission to Russia. Returning in March of the same year he was given command of the eastern group of armies, and in this appointment he remained till the end of the war. In Sept. 1917 he was awarded the médaille militaire. Political animosities alone prevented his being promoted to the dignity of Marshal of France, along with D'Espérey, Lyautéy and Fayolle, in 1921.

**CAVALRY:** see MOUNTED TROOPS.

**CAVE, GEORGE CAVE, 1ST VISCOUNT (1856- )**, British politician and lawyer, was born in London Feb. 23 1856. He was educated at Merchant Taylors' school and St. John's College, Oxford, and was called to the bar in 1880. He practised at the Chancery bar, and in 1904 became a K.C. In 1906 he was elected Unionist M.P. for Kingston, and on the formation of the Coalition Government in 1915 was made Solicitor-General and knighted. He became Home Secretary in 1916 on the accession of Mr. Lloyd George to power, and in this capacity was very prominent in the debates in the House of Commons on the police strike of Aug. 1918. In Nov. 1918 he resigned office, and was created a viscount, becoming in Jan. 1919 a lord of appeal.

**CAVELL, EDITH (1865-1915)**, British nurse, was born Dec. 4 1865 at Swardston, Norfolk, the daughter of the Rev. Frederick Cavell, vicar of that parish. She was educated at various schools in England and in Brussels, and entered the London hospital as a probationer in 1895. After five years at the hospital she was successively night superintendent at the St. Pancras infirmary, assistant superintendent at Shoreditch infirmary and matron at the Ashton New Road district home, Manchester. In 1907 she was appointed the first matron of the Berkendael medical institute, Brussels, a surgical and medical home founded by Dr. de Page as a pioneer training school for Belgian secular nurses. The institute became a Red Cross hospital on the outbreak of the World War, in which Belgian, German, French and English soldiers were nursed. From Nov. 1914 to July 1915 wounded and derelict English and French soldiers and Belgians and French of military age were hidden from the Germans and provided with false papers by Prince Reginald de Croÿ at his château of Bellignie near Mons; thence conducted by various guides to the houses of Edith Cavell, Louis Séverin and others in Brussels, and furnished by them with money to reach the Dutch frontier and with

guides obtained through Philippe Baucoq. On Aug. 6 Edith Cavell was arrested at the Berkendael institute and sent to the prison of St. Gilles. She made three depositions to the German police, Aug. 8, 18, and 22, admitting that she had been instrumental in conveying about 60 English and 15 French derelict soldiers and about 100 French and Belgians of military age to the frontier and had sheltered the greater number in her house. Thirty-five persons were arrested. The court-martial was held, Oct. 7 and 8, before Dr. Stoerber and five judges, and a Belgian lawyer, M. Sadi Kirschen, defended Edith Cavell. On Oct. 9 Edith Cavell, Louise Thuliez, Philippe Baucoq, Louis Séverin and Countess Jeanne de Belleville were secretly sentenced to death; and of the remaining 30, 22 were sentenced to imprisonment and 8 acquitted. On the 10th the sentence was announced in secret to the prisoners. Gen. von Sauberzweig, the military governor of Brussels, ordered that "in the interests of the State" the execution of the death penalty against Baucoq and Edith Cavell should be carried out immediately. At 7 A.M. on Oct. 11 they were shot at the Tir National, Brussels, in spite of the energetic attempts to secure delay made by the American minister, the secretary of the American legation and the Spanish minister, who first became aware of the sentence during the night of the 10th. The other three were reprieved. These were the first death sentences imposed by the Germans in Belgium for recruiting as opposed to espionage. On May 15 1919 the body was removed to Norwich cathedral, after a memorial service in Westminster Abbey. A memorial statue, by Sir G. Frampton, is erected opposite the National Portrait Gallery, London.

See *The Case of Miss Cavell from the Unpublished Documents of the Trial*, interpreted by Ambroise Got; Sadi Kirschen, *Deuxes les Conseils de Guerre Allemands (1919): Correspondence with the United States Ambassador respecting the Execution of Miss Cavell at Brussels*, Cd. 8013, Stationery Office (1915).

**CAVIGLIA, ENRICO (1862- )**, Italian general, was born at Finalmarina (Genoa) May 4 1862. He entered the artillery, and his early years in the army were spent between this branch of the service and the general staff, but on attaining his majority he passed to the infantry arm. He served in Eritrea and in the Italo-Turkish War and, as a captain of the general staff, was attached to the Japanese army during the Russo-Japanese War. In Feb. 1914 he was nominated vice-director of the Military Geographical Institute in Florence. On Italy's entry into the World War he served as a colonel on the general staff, and in Aug. 1915 he was promoted to major-general and given command of the Bari Brigade. In June 1916 he took over the 29th Div. and two months later was promoted lieutenant-general "for war merit." In July 1917 he was given command of the XXIV. Corps, which under his direction broke through the Austrian lines on the Bainsizza plateau. After Caporetto he took command of the VIII. Corps and subsequently of the X., and in June 1918, after the Austrian offensive on the Piave, he was chosen to command the VIII. Army. Under his leadership the VIII. Army played an important part in the final victory of Vittorio Veneto. From Jan. to June 1919 Caviglia was Minister of War, and as such became a senator, and in Nov. of the same year he was promoted army general. In Jan. 1920 he took over the command of the troops in Venezia Giulia, with headquarters at Trieste. He had a very difficult task to perform, since the discipline of the troops had been severely shaken by the example of D'Annunzio's Fiume raid, and there was danger of trouble on the frontier with the Yugoslavs. Caviglia restored discipline, and showed both firmness and tact in dealing with these delicate problems. When it became evident that only force would drive D'Annunzio from Fiume he did not hesitate to carry out his task.

**CECIL, LORD HUGH RICHARD HEATHCOTE (1869- )**, English politician (see 24.76), youngest son of the 3rd Marquess of Salisbury, was born Oct. 24 1869, and was educated at Eton and University College, Oxford. He obtained a first class in history in 1891 and was elected a fellow of Hertford College. He gained his first insight into politics as one of his father's private secretaries, and was returned to Parliament as a Conservative for Greenwich in 1895. Ecclesiastical questions were

those in which he took the keenest interest, and he became an active member of the Church party in the House, resisting the attempts that were made by Nonconformists and Secularists to take the discipline of the Church out of the hands of the archbishops and bishops, and to remove the bishops from their seats in the House of Lords. In these debates he showed remarkable oratorical power and loftiness of tone, and established a reputation which was confirmed and heightened during the progress through Parliament of Mr. Balfour's Education bill of 1902. In an earnest speech on the second reading he maintained that for the final settlement of the religious difficulty there must be cooperation between the Church of England and nonconformity, which was the Church's natural ally; and that the only possible basis of agreement was that every child should be brought up in the belief of its parents. The ideal to be aimed at in education was the improvement of the national character. In the latter stages of the bill's progress he warmly resented an amendment approved by the House and taken over by the Ministry giving the managers, instead of the incumbent of the parish, the control of religious education in non-provided schools. This was not the only point on which he showed considerable independence of the Government of which his cousin Mr. Balfour was the head: He and Mr. Winston Churchill gathered round them a small group of young and able Conservative members, whose independent proceedings attracted some attention in Parliament, and who formed a sort of pale reflection of Lord Randolph Churchill's Fourth party. He dissented from the beginning from Mr. Joseph Chamberlain's policy of tariff reform, pleading in Parliament against any lowering of our idea of empire into that of a "gigantic profit-sharing business." He took a prominent position among the "Free Food Unionists," and consequently was attacked by the tariff reformers and lost his seat at Greenwich in 1906. He did not return to Parliament until 1910 when his high character and his academic outlook recommended him, in spite of his hostility to tariff reform, as a fitting member for Oxford, his own university. He threw himself immediately with passion into the struggle against the Ministerial Veto Resolutions, comparing the Asquith Government to "chimble-rippers." In the next year he was active in the resistance to the Parliament bill, treating Mr. Asquith as a "traitor" for his advice to the Crown to create peers, and taking a prominent part in the disturbance which prevented the Prime Minister from being heard on July 24 1911. But he never quite regained the authority which he had possessed in the House in the early years of the century. He strongly opposed the Welsh Church bill; and he denounced the Home Rule bill, in a picturesque phrase, as reducing Ireland from the status of a wife to that of a mistress—she was to be kept by John Bull, not united to him. During the World War Lord Hugh joined the Flying Corps, becoming a lieutenant R.F.C. in 1915, and in that capacity he severely censured, in debate in 1918, the treatment of Gen. Trenchard by the Government. He also served in 1917 as a member of the commission to enquire into the Mesopotamian expedition. In Parliament he pleaded for lenient treatment of conscientious objectors to the Military Service bills; and endeavoured unsuccessfully to relieve them of disability under the new Reform Act. After the war he took a less active part in politics, but generally found himself in agreement with his brother Lord Robert, whom he followed into Opposition in 1921.

(G. E. B.)

**CECIL LORD (EDGAR ALGERNON) ROBERT** (1864— ), English lawyer and statesman (see 24.76), third son of the 3rd Marquess of Salisbury, was born Sept. 14 1864. Educated at Eton and University College, Oxford, he obtained a second class in law in 1886. He was a prominent speaker at the Oxford Union, and obtained political experience as one of his father's private secretaries from 1886 to 1888; but he determined to approach an active political career by way of the bar, and was called by the Inner Temple in 1887. He made such progress in his profession that he could take silk in 1899; and he established his position as a sound lawyer and capable advocate. It was not till 1906 that he entered Parliament as Conservative member for

E. Marylebone, and he was one of the principal critics of Mr. Birrell's abortive Education bill of that year, contending throughout that facilities should be afforded for the training of children in the religion of their parents. In this he carried on the work of his younger brother, Lord Hugh Cecil, now out of Parliament. But, though a vigilant champion of Church interests, as for instance in opposition to the Deceased Wife's Sister's bill, he also took up, in conjunction with Mr. Harold Cox on the Liberal side, an attitude of individualist opposition to Socialist measures, such as Miners' Eight Hours, Old Age Pensions, and Increment Taxation bills. He also dissociated himself from the tariff reform policy of his party. He had won a leading place among the private members of the House, when Parliament was dissolved in 1910. He then retired from Marylebone, owing to the strong opposition of the tariff reformers, and failed to secure election as a Unionist free trader at Blackburn. In the second General Election of 1910 he stood for N. Cambridgeshire but was beaten by Mr. Neil Primrose. However, he returned to Parliament at a by-election in 1912 as member for the Hitchin division of Herts., the tariff reform issue being now in abeyance. He immediately resumed his prominent position in the House, and was active in his opposition to schemes of socialism and disestablishment. He was a leading advocate of woman suffrage; and, though not palatially militant, was a strong critic of forcible feeding. Ultimately, after women had been granted the suffrage under the Reform Act of 1918, he had the satisfaction of carrying a resolution permitting them to sit in Parliament.

By the time of the outbreak of the World War his claims to recognition among the Unionist leaders were so considerable that he was appointed Under-Secretary for Foreign Affairs in the first Coalition Ministry. His functions mainly concerned the vitally important question of blockade; and when there was a considerable outcry against the comparative ineffectiveness of our blockade, a new Ministry of Blockade was constituted, in Feb. 1916, with Lord Robert as minister. In that capacity he announced in June 1916, to the general satisfaction, that the Allies had decided to abandon altogether the Declaration of London. His work was so much appreciated that he was retained both as Minister of Blockade and as Foreign Under-Secretary in Mr. Lloyd George's Ministry of Dec. 1916. In July 1918 the labours of the Foreign Office became so considerable that he was relieved of the Ministry of Blockade, and became Assistant Secretary of State for Foreign Affairs, retaining that important post through the negotiations which resulted eventually in the Armistice; but he resigned on the eve of the General Election, on the ground that he could not support the decision of the Coalition Ministry to treat Welsh disestablishment as a *fait accompli*. Though out of office, he nevertheless went over to Paris in 1919 to help to fashion the League of Nations, of which from the first he was an enthusiastic advocate. He was subsequently indefatigable in pressing his claims upon Parliament and people, urging that the sooner enemy nations, including Germany, could be included in it with safety, the better. In 1920 he attended the first assembly of the League at Geneva as the representative of South Africa at the request of Gen. Smuts; himself a convinced believer in this new international organ. He also took a large share in Parliamentary debate, appearing, for instance, as a strong supporter of the Church Enabling bill, and criticizing the policy of the War Graves Commission and the regulation headline which it recommended. In spite of his protestation, when he left the Government, that except on the one point of the Welsh bill, he was a convinced supporter, he steadily drifted into opposition, being especially alienated by their gigantic budgets, and by the policy of reprisals in Ireland. At one time both extreme Tory and visionary Radical thought they saw in him the leader of the future; but when he ultimately took his seat on the Opposition front bench in 1921, he did not appear to carry anyone across the House with him, except his brother, Lord Hugh.

Lord Robert Cecil married, in 1889, Lady Eleanor Lambton, daughter of the 2nd Earl of Durham. (G. E. B.)

**CELLULOSE** (see 5.666).—The decade following the year 1910, including the experiences of the World War, fully confirmed



the scientific estimate of the importance of cellulose as an industrial product. The production of cellulose nitrate, the basis of modern military explosives, attained in 1918 to 5,000 tons per week in America alone. Another ester derivative of cellulose, the acetate, took a prominent and perhaps unique position in regard to war material, as the basis of the dope-dressing applied to the textile coverings of the wings of aeroplanes. The intensive production of these synthetic derivatives necessarily involved extensions of research with resulting additions to our knowledge of cellulose as a chemical individual, and in evidence of the magnitude of these industries and the wide scope of their technology we may refer to E. C. Worden's elaborate treatise on the "Nitro Cellulose Industries." In evidence of the rapid growth of the subject in its wider aspects we may refer to the same author's treatise (projected in 1921), to be issued in ten volumes over a period of years.

Progress of investigation and knowledge of cellulose as a chemical individual was in 1921 more definitely marked as following three independent lines, obviously converging towards a constitutional formula or expression: (1) The study of cellulose as it is; a colloidal substance, perhaps the prototype of colloids, and of its immediately related derivatives, having closely similar physical properties. (2) The study of its resolutions by reaction to compounds of  $C_{17}$ - $C_6$  dimensions, also carbo-hydrates, which are presumed to be actual components, and, being compounds of known constitution, to be the foundation of an integral formula of constitution of the parent substance. With this primary or fundamental method is associated the study of the whole range of reactions and interactions of cellulose as diagnostic of its component groups. (3) The study of resolutions (a) to highly complex mixtures of products, by destructive distillation, or by natural processes of which the ultimate residual products are humus-lignite coal; (b) to ultimate products of  $C_3$ - $C$  dimensions by symbiotic bacterial process of decomposition.

Of the above, No. 2 is the line or method of systematic chemistry, and its exponents detach themselves in the main from all considerations of the natural history and physiology of the celluloses: their organized structure and colloidal characteristics are treated as of subordinate moment, and the technology of the cellulose industries is for the most part ignored. Nevertheless, the contributions of this school of workers are of first importance.

The following are to be noted:—

**Resolution to Dextrose** by ester formation, solution in water, and progressive hydrolysis of esters: (a) Reaction with  $H_2SO_4$ —Ost & Wilkening (1910-3) confirm Flechsig (1882) in the general conclusion that cellulose is quantitatively converted to dextrose; (b) reaction with  $HCl$ . Aq. Willstätter and Zechmeister (1913), rediscovering the solvent action of the acid at maximum concentration (W. A. Miller, *Organic Chemistry*, p. 130, ed. 1869), apply the reaction to an analogous process of resolution and further confirm the generally accepted relationship.

**Resolution to Diox (cellobiose) and Monose (dextrose)** following conversion into (a) acetic ester and (b) methyl and ethyl ethers or ethoxides (c) mixed (acetic) ester—ether derivatives. By the former, Ost has demonstrated the production of the biose as octacetate with the monose as pentacetate, the joint yield calculated to the monose representing 90% of the cellulose. By resolution of the methoxided derivatives Denham and Woodhouse obtain 1,2,5-trimethyl glucose and establish a critical constitutional point in regard to current discussion of the several alternative formulae based on the general acceptance of the quantitative cellulose—dextrose relationship. The "acetylosis" of the ethoxides has been specially investigated by Hess and Wittelsbach.

**Resolution by Heat to Laevo-glucosan.**—A direction of research of critical importance is opened up by A. Pictet and co-workers, and subjecting cellulose (starch and glucose) to distillation *in vacuo* (12.4 mm. at 210°) with production of laevo-glucosan

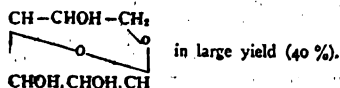

*Helvetic Chem. Acta*, 1918-20; also P. Karrer, *ibid.* 1920.

These notes are sufficient as evidence of the rapid advance of knowledge due to the active work and discussions of the chemists

whose *ultima thule* is expressed by a recent contributor:—"The time would now seem to be opportune when the question of direct synthesis should be undertaken." This project issues from a comprehensive critical discussion of the research work of the last decade (H. Hibbert, "The Constitution of Cellulose," *Jour. Ind. Eng. Chem.* 13 (1921), 276 et seq.), of which the following is characteristic:—"Cellulose is thus nothing more than a polymerised dextrose glucoside of dextrose."

As indicated above, the perspective of this school of workers is that of systematic chemistry, self-contained, and perhaps arbitrarily delimited from the objective relationships of cellulose as a dominant factor of the organic world and a main subject of natural history of which the complementary chapters are those of human industries.

Investigations from this point of view have also established points of critical importance:—

1. The primary importance of specific volumes of cellulose and derivatives, for the adequate interpretation of reaction in this field.  
2. The reactive continuity of cellulose: it reacts as a system, whereas systematic chemistry interprets its reactions in terms of a "molecular" individual.

3. Cellulose is profoundly modified, structurally and constitutionally by mechanical shock and strain: as it is in degree proportionate to the active influence by all forms of energy (light, electrical current, heat).

4. Cellulose is resolved by bacteria to ultimate products of  $C_2$ - $C_1$  dimensions: and recent research has brought these reactions under such control that the massive treatment of the "normal" celluloses is an industrial operation of the order of starch fermentations. It is noteworthy that these transformations are in the main direct, and do not involve the transitional phases of the familiar operations of the brewer and distiller.

5. Lastly, as a negative point and a general criticism of the conclusions of the school of systematic chemists, the cellulose-dextrose relationship postulating a conversion of 100 of cellulose to 111 dextrose is not established. Research in this field is limited to cotton cellulose. If extended to esparto cellulose (a type sharply and characteristically differentiated), to the wood celluloses, or even to cotton cellulose modified by mercerization and other treatments yielding products which maintain the structural characteristics, it would be recognized in the results that the "constitution of cellulose" is a problem of the dimensions of a continent rather than of a village; or possibly, that the "synthesis of cellulose" is an ideal, illusory, however useful. (The reader is referred to C. F. Cross, *Canter Lectures "Cellulose" J. R. Soc. Arts* 1920; and to papers by same author in *J. Soc. Dyers and Col.* 1918-20.)

**Cellulose Products in War Service (1914-8).**—The following note on the development of the technology of the cellulose nitrates to meet the exacting requirements of the fighting services is contributed by Sir R. Robertson, who, as director of research at Woolwich, was responsible for the chemical technical control of the manufacture.

In England cellulose nitrates were used during the war in the Land Service for the manufacture of cordite R.D.B., and for Admiralty cordite; towards the end of the war a small proportion was used for making nitro-cellulose powder. By far the largest use was for cordite R.D.B., as this propellant was ultimately manufactured at the rate of about 2,000 tons a week, involving the nitration of about 700 tons of purified cellulose. For Admiralty cordite over 100 tons a week of sliver cotton was prepared, this material being specially selected and purified. The cotton for the nitro-cellulose powders was a high grade of "liners."

The preparation of cellulose for the Land Service assumed the proportion of a great industry. The raw materials were drawn from wastes from the spinning-mills not only of England, but also of Egypt, India, and of other countries. It was soon found that the variations in treatment of the crude wastes produced a product which gave variable results after it had been nitrated, especially when it reached the stage of its incorporation with nitro-glycerine and gelatinization by means of ether-alcohol. All the materials for producing cellulose for nitration were therefore coordinated under the Department of Explosives Supply, which instituted a system of chemical control of the product, with the objects of obtaining uniformity of production, reducing the quantity of impurities, and obtaining a suitable low viscosity. A uniform process of "kiering" (boiling under pressure with a lye of caustic soda) was introduced, and under strict supervision it

product was obtained of remarkable purity, considering its origin, and suitable for the manufacture of cordite R.D.B.

The result is an example of the successful application of chemical technical control to secure a product of standard uniform quality, and by reason of the quality of low viscosity of the nitrated product a very considerable economy in the ether-alcohol, for gelatinizing the nitro-cellulose. The methods for determining the viscosity of the cellulose, and a method for determining ligneous impurities in the cellulose (*Trans. Chem. Soc.* 1920, 117, 473 and 479, and *Jour. Soc. Chem. Industry*, 1920, 39, 81 T) were worked out at the Research Department, Woolwich. The application of this work on cellulose by the Department of Explosives Supply is described in *Jour. Soc. Chem. Industry*, vol. 39, 333 T.

The United States supplied large quantities of nitro-cellulose propellant for the Allies and for its own army, and used as raw material a considerable proportion of the shorter fibre "waste" from the delinted cotton seed. During the last three months of the war the total production of cellulose nitrate material in the United States was at the rate of 5,000 tons a week. This propellant consisted of gelatinized nitro-cellulose with the addition of a stabilizer, but it contained no nitro-glycerine.

In the enemy countries the shortage of cotton supplies was met by the extensive employment of wood cellulose, paper-makers' cellulose pulp, purified by alkaline hydrolytic treatments, which modify the cellulose to a nearer approximation to the standard cotton cellulose.

**Cellulose Acetate.**—The cellulose acetates are the chemical analogues of the nitrates, and a specially prepared acetone soluble acetate was extensively used in dressing the textile coverings of aeroplane wings, the treatment having an ensemble of effects, producing shrinkage of the fabric *in situ*, thus a taut finish, a smooth surface and the water-resistant quality obviously indispensable.

In England the manufacture of the product was developed by The British Cellulose Co. on the basis of the Dreyfus patents who, since 1918, have been engaged in perfecting the "Artificial Silk" based upon the acetate. This product has the external features of the cellulose "Silks," with certain points of superiority of the ester-derivative as a chemical substance, notably the water-resistant quality and lower specific gravity. On the other hand, certain defects, as a textile thread, with high costs of manufacture, keep the present production to a definitely limited scale.

Other lines of development followed more particularly under the stress of war conditions and the resulting contributions to progress are treated in the article *Fishes*. One section requires further mention here in introducing the comprehensive subject of cellulose as a dominant factor of the organic world. Recent research work has established on a basis of direct proof that cellulose is assimilated by the Herbivora and has therefore a positive value as food-stuff; a conclusion which rested previously on inferential evidence from physiological-chemical statistics. The positive flesh-forming function postulates conversion of the cellulose into water-soluble derivative, carbo-hydrates probably, as a digestive process in which the animal secretions are operative; at the same time there are the distinctive fermentations, previously mentioned, of the celluloses to ultimate products, under bacterial action, which are known to occur in the digestive tract of the animal and of which the physiological value or function remains undetermined.

Such fermentations, characterized by the researches of Omeliansky and Macfadyen, in regard to "Thermophilic" bacteria, and hitherto "pure" cultures of these have however been observed as processes of long duration. The current developments of an industrial research syndicate, Power Spirit, Ltd. (Stockton-on-Tees and Epsom), and H. Langwell are establishing such fermentations as industrial methods for the production of acetic acid and alcohol.

Symbiotic bacterial growths at 30°-40° C. are now controlled, by the associated chemical conditions of reaction, to produce ether as main product, and to break down the celluloses in massive quantities in the relatively short periods which are required for starch fermentations.

In another field, which is also comprised in the vast domain of the natural history of "cellulose," researches are being actively prosecuted in elucidation of the constitution of the peat-lignite coal groups of natural products, obviously derived from, and transformation products of, "cellulose" in the inclusive sense of the term.

The **Hemic-Celluloses** have a typical representative in the parenchyma of the "locus" bean, the seeds of *Lepidion siliqua*. On digestion with water the cellular tissue is transformed into a series of hydrated gel-products which mix with the water to pseudo-sol-

tions of extreme specific viscosity. The products (Tragnapol) find extensive application as a dressing or "finish" of textile goods and leathers. These hydrated hemic-celluloses combine with tannic acid to form characteristic precipitates which are reversible gels. The reactions and properties of these compounds are the basis of new processes of hide tanning. An exposé of these methods with the rationale of principles will be found in an article "Colloidal Tannin Compounds" (C. F. Cross and others) *J. Soc. Dyers and Colourists* 35 (1919), 62-8.

**The Compensated-Celluloses.**—The ligno-celluloses, represented by the typical fibre-substance of jute (bast-fibre), are the subject of a paper "Lignum Reactions and Constitution,"—Cross and Bevan, *J. Soc. Dyers and Col.* 32 (1916), giving an account of researches which establish a statistical constitutional formula for the lignine complex of which a dioxetohydrobenzene and a hydro-pyrene group are characteristic; in addition, as secondary components are ketene and methoxy groups.

The lignous components of perennial ligno-celluloses—the wood of forest trees—have been further investigated by: Klason, *Ber. Ber.* 53 (1920), 706, 1864; Heuser and Ståldbrand, *Z. Angew. Chem.* 32 (1919), 41; Hägglund, *Chem. Zentr.* 90 (iii) (1919), 1885; Hägglund and Fuchs, *Momath.* 40 (1919), 341.

**The Cuto-Celluloses**, the protective epidermal covering of plant organs, especially of the organs or parts functioning in active assimilation, are relatively inaccessible by reason of their minute proportion by weight or mass, and from the fact that they require chemical treatment more or less severe for their isolation as a separated tissue, which treatments produce considerable modifications of the parent substances. The epidermal tissue "raffia" on the other hand is separated by merely stripping from a palm leaf; being thus obtainable in massive quantity and investigated as a "parent" substance, it is an attractive subject for developing this field of research. It is however a mixed tissue of which the actual epidermis constitutes about 40%; therefore, the quantitative data resulting from investigation require inferential interpretation in regard to the latter. Recent researches establish the general character of the tissue complex as an (oxidized) cellulose—ligno-cellulose ether ester with acid functions. The characteristic acid component of the ester is an unsaturated acid  $C_{11}H_{16}O_2$ —containing 1 COOH and 1 OH group "Raffia and Cuto-cellulose."—Cross and Bevan, *J. Soc. Dyers and Col.* 33 (1919), 70-5. (C. F. C.)

**CENSORSHIP.**—The World War brought about various forms of restriction of publicity in the shape of a censorship, which provides a new chapter in the history of the Press Laws (*see* 22,299).

(1) UNITED KINGDOM.—The following note to newspaper editors, dated July 27 1914, was the first official intimation to the British press of the approach of war:—

"At a meeting of the Admiralty War Office and Press Committee, held this afternoon, it was resolved that as, in view of the present situation, the authorities may have to take exceptional measures, the Press should be asked to refrain from publishing any information relative to movements of British warships, troops, and aircraft, or to war material, fortifications, and naval and military defenses, without first communicating with the Admiralty and War Office respectively in accordance with the arrangement which was notified to you by me in January of last year.

"Having regard to the nature of the case it is found impossible further to indicate the character of the information the publication of which is undesirable in the national interests. The request does not affect the dissemination of news concerning ordinary routine movements or training on the part of the Navy or the Army; its object is to prevent the appearance of anything concerning steps of an exceptional kind which may be rendered necessary by the existing state of affairs.

"I may add that the authorities from time to time will continue to issue such information as may be made public."

The "Admiralty War Office and Press Committee" had been formed in 1911, mainly through the efforts of Mr. (afterwards Sir) Reginald Brade, to establish a permanent liaison in peace and war between the Admiralty and the War Office on the one hand and the Press on the other. The Committee consisted of representatives of the two departments and the London and provincial newspapers. Apart from the Official Secrets Act, no legislation existed which enabled the authorities or the Committee to suppress the publication of naval and military information. Notwithstanding this, the whole of the newspapers loyally observed the Committee's request, followed by others of a more detailed character, dated July 29 and 30 respectively. The result was that the British preparations were made with such secrecy that the Germans subsequently admitted that on Aug. 20 they knew neither when nor where the British troops were landed, nor their strength.

On Aug. 7 the Press Bureau (the outward and visible sign of the censorship) was established by Lord Kitchener, acting in conjunction with Mr. Churchill, then First Lord of the Admiralty. The first Director of the Bureau was Mr. F. E. Smith, M.P., afterwards Lord Birkenhead. He was followed by Sir Stanley (afterwards Lord) Buckmaster, who was succeeded by Sir Frank Swettenham jointly with the late Sir Edward Cook. In the first instance the Bureau was located in a tumble-down building in Whitehall, backing on to the Admiralty. Later it was removed to the United Service Institution.

The objects of the Press Bureau were—

(1) The censoring of incoming and outgoing press cablegrams and certain inland press messages, chiefly those passing through the General Post Office. By order of the Government the former were diverted to the Bureau by the Post Office and cable companies.

(2) To issue to the newspapers official information received from other Government departments.

(3) To censor matter voluntarily submitted by the Press.

It should be mentioned here that the censoring of news by the Bureau was, for the most part, carried out in accordance with the wishes of the various Government departments concerned—the Admiralty, the War Office, the Foreign Office, the Home Office, etc., with the result that the whole of the criticism was directed against the Bureau, which served as a sort of buffer state. In short, the Directors of the Bureau had to do as they were told. It was an open secret that in some instances they disagreed with the policy they were called upon to enforce. On the whole they performed a thankless duty with considerable ability. Upon Lord Birkenhead fell the difficult task of organizing the department and establishing regulations to deal with conditions altogether unprecedented. The work of his successors was hardly less onerous as fresh problems constantly presented themselves throughout the war. About fifty censors were employed, comprising naval officers (appointed by the Admiralty), military censors (appointed by the War Office), and civilians, including ex-civil servants, barristers and journalists.

The Bureau was kept open day and night. On Aug. 8 1914 the Defence of the Realm Act was passed, followed a few days later by a series of censorship regulations as authorized by its provisions. These regulations were of a far-reaching character. They were amended from time to time and in their final form stood as follows:

Reg. 18. No person shall, without lawful authority, collect, record, publish or communicate, or attempt to elicit, any information with respect to the movement, numbers, description, condition or disposition of any of the forces, ships, or aircraft of His Majesty or any of His Majesty's allies, or with respect to the plans or conduct, or supposed plans or conduct, of any operations by any such forces, ships, or aircraft, or with respect to the supply, description, condition, transport or manufacture, or storage, or place or intended place of manufacture or storage of war material, or with respect to any works or measures undertaken for or connected with, or intended for the fortification or defence of any place, or any information of such nature as is calculated to be or might be directly or indirectly useful to the enemy, and if any person contravenes the provisions of this regulation, or without lawful authority or excuse has in his possession any document containing any such information as aforesaid, he shall be guilty of an offence against these regulations. . . .

No person shall, without lawful authority, publish or communicate any information relating to the passage of any ship along any part of the coast of the United Kingdom. . . .

Reg. 27. No person shall by word of mouth or in writing or in any newspaper, periodical, book, circular, or other printed publication—

- (a) Spread false reports or make false statements; or
- (b) spread reports or make statements intended or likely to cause disaffection to His Majesty, or to interfere with the success of His Majesty's forces, or of the forces of any of His Majesty's allies by land or sea, or to prejudice His Majesty's relations with foreign powers; or
- (c) spread reports or make statements intended or likely to prejudice the recruiting of persons to serve in any of His Majesty's forces, or in any body of persons enrolled for employment under the Army Council or Air Council or entered for service under the direction of the Admiralty, or in any police force or fire brigade, or to prejudice the training, discipline or administration of any such force, body, or brigade; or
- (d) spread reports or make statements intended or likely to undermine public confidence in any bank or currency notes which

are legal tender in the United Kingdom or any part thereof, or to prejudice the success of any financial measures taken or arrangements made by His Majesty's Government with a view to the prosecution of the war; . . .

The maximum penalty was imprisonment with or without hard labour for six months or a fine not exceeding £100, or both. Prosecutions had to be instituted by the Director of Public Prosecutions in England, the Lord Advocate in Scotland, or the Attorney-General in Ireland. The Regulations (Regulation 51) gave the Government power in certain cases to seize the plants of a newspaper which had offended, or in others to seize the type on suspicion that an offence was about to be committed (Reg. 51a).

These regulations placed heavy shackles upon the Press, but in the main they were accepted with patriotic equanimity. Prosecutions were few in number, which is surprising considering the length and magnitude of the war. It will be seen that the Press Bureau had no power to insist upon the submission of matter for censorship. The responsibility rested with the editor, who could publish what he thought fit, subject to complying with the Defence of the Realm Regulations. If he erred he was liable to prosecution, and even if the matter were passed by the Bureau he would not be relieved of the responsibility for infringement of the regulations, although the fact might be pleaded in mitigation. From time to time secret instructions were issued by the Bureau for the information and guidance of editors. At the end of the war these numbered several hundred. At intervals they were collected and issued in pamphlet form. For the most part they consisted of hints and elucidations concerning matters which in general terms were covered by the regulations quoted above.

*Cable and Postal Censorship.*—In addition to the Press Bureau, censorships of incoming and outgoing cables, letters and parcels, were established by the War Office at the commencement of the war with the three-fold object of preventing information of military value from reaching the enemy, of acquiring similar information for British purposes, and of checking the dissemination of information likely to be useful to the enemy or prejudicial to the Allies. Chief Censors of both departments were appointed by the Army Council.

The cable censorship extended throughout the Empire, and the number of persons employed in the United Kingdom, exclusive of those in the Press Bureau, was about 200. In other parts of the Empire they numbered about 400. The size of the task may be judged from the fact that 30,000 to 50,000 telegrams passed through the hands of the censors in the United Kingdom every twenty-four hours.

In the postal censorship, exclusive of clerical and post-office employees, a staff of 5,500 was employed comprising 3,451 women and persons with a knowledge of almost every foreign language. The department was divided into three branches—

(1) the section which censored the correspondence of prisoners of war in the United Kingdom and British prisoners in enemy countries; (a) the private correspondence section which dealt with letters from members of the British Expeditionary Force, letters and parcels to and from certain foreign countries, press messages sent abroad by other means than cable, and newspapers. In this branch more than a ton of mail matter was censored every week, exclusive of parcels; (3) the trade branch, which censored commercial correspondence with certain foreign countries, amounting to nearly four tons per week.

At the commencement, the system caused serious irritation amongst the commercial classes, to which point was given by foolish and, in some cases, amusing errors made by the censors. It must, however, be recognized that on the whole the work was well and efficiently done. The officers chiefly responsible were Gen. (afterwards Sir George) Macdonogh, Gen. Cockerill, Col. A. E. Churchill followed by Lord Arthur Browne, Chief Cable Censor, and Col. G. S. H. Pearson followed by Col. A. S. L. Farquharson, Chief Postal Censor.

In the early part of the war a great outcry was made by the British (and also the American) newspapers concerning the working of the Press cable censorship in London. In numerous instances, Press cables received in England were entirely suppressed without notice to the sender or addressee, and in others

messages were so mutilated as to be indecipherable. These complaints led to a declaration by the Foreign Office on Dec. 20, 1915, that in future incoming press cablegrams would not be censored from a political point of view; the responsibility of publishing would be with the editors who knew that a prosecution against them, under the Defence of the Realm Act, might result from the publication of anything endangering the good relations between Great Britain and the Allies or the Neutrals. This change, however, only applied to censorship by the Foreign Office, and messages were still liable to censorship from the point of view of other departments (Admiralty, War Office, Home Office or Treasury, for instance) consulted by the Press Bureau—a system which continued until 1919.

*Censorship at the Front.*—It remains to deal with the censorship of messages from authorized British correspondents on the several fronts. These were primarily (and compulsorily) censored by military censors on the field, but they all came through the Press Bureau, which occasionally exercised a super-censorship. The methods adopted caused constant grumbling and discontent.

The casualty lists were rigidly and, no doubt, properly suppressed, but owing to the representations of the Newspaper Proprietors' Association they were supplied periodically for the confidential information of editors.

In France, at the outset, no correspondents were allowed. In Sept. 1914, owing to demands by the Newspaper Proprietors' Association for more information, an official eye-witness, Gen. Swinton, was appointed. He wrote according to order, and no question of censorship arose. The news supplied was meagre and inappropriate, and it did not take long for mischievous results to accrue, and the official mind was at first disposed to blame the Press for what was wrong in the "publicity" of the moment. On March 12, 1915, the following notice was issued by the Press Bureau, warning the newspapers that they were too optimistic in the pictures they gave of what was happening:—

"The magnitude of the British task in this great war runs serious risk of being overlooked by reason of exaggerated accounts of successes printed daily in the Press and especially by exhibiting posters framed to catch the eye and magnify comparatively unimportant actions into great victories. Reported reverses to the enemy are proclaimed as crushing defeats, Germany is represented as within measurable distance of starvation, bankruptcy and revolution, and only yesterday a poster was issued in London, declaring that half the Hungarian army had been annihilated.

"All sense of just proportion is thus lost, and, with these daily, and often hourly, statements of great Allied gains and immense enemy losses, the public can have no true appreciation of the facts or of the gigantic task and heavy sacrifices before them."

"The Director appeals to all those who are responsible for the Press to use their influence to bring about a better knowledge of the real situation, and rather to emphasize the efforts that will be necessary before the country can afford to regard the end for which we are striving as anything like assured. The posters, more especially those of the evening papers, are very often preposterous as well as misleading, and, at such a time, those responsible may fairly be asked to exercise a reasonable restraint and help the nation to a just appreciation of the task it has undertaken and the necessity for unremitting effort to secure the only end that can be accepted."

The newspapers did not take this notice "lying down." On March 26 the Newspaper Proprietors' Association, through its chairman Sir George (afterwards Lord) Riddell, sent the following letter to the Press Bureau, and copies to the Prime Minister, Mr. Winston Churchill, Lord Kitchener and other members of the Cabinet:—

"My Council have had under consideration your Memorandum of 12th March, 1915, Serial No. D. 183, for which, in their opinion, there is no adequate justification. The Press has dealt faithfully with the news furnished by the naval and military authorities, but it may well be that the public misunderstands the situation and that this misconception is producing serious results. If, however, the people are being unduly soothed and elated the responsibility lies with the Government and not with the Press. In this connection my Council desire to direct your attention to the optimistic statements of the Prime Minister, Sir John French, 'Eye-Witness,' and other persons possessing official information. The Press acts upon the news supplied. If this is inaccurate or incomplete, the Government cannot blame the newspapers. My Council desire to represent that the methods now being adopted are fraught with grave public danger. Ministers are continually referring to the importance

of energy and self-sacrifice on the part of the industrial population, who cannot be expected to display these qualities unless, generally speaking, they are acquainted with the facts. In dealing with the news, the Naval and Military authorities should consider not only our enemies and the army in the field, but the commercial and industrial classes at home, upon whom so much depends. It is futile to endeavour to disregard the long-established habits and customs of the people.

"As you know, I am writing on behalf of the London Press only, but my Council are confident that their views are shared by the provincial newspapers."

The result of this letter was that Mr. Asquith invited the Association to lay their views before him at a deputation. A free exchange of views took place, with the result that Mr. Asquith invited the Press to appoint a representative who would interview Lord Kitchener and Mr. Churchill each week with the object of putting questions to them and receiving private information for circulation to editors. Lord Riddell was detailed for the duty, and had frequent interviews with Lord Kitchener.

As a result of further urgent representations by the Association, represented by Lord Burnham, Lord Northcliffe and Sir George Riddell, the following correspondents were authorized in May 1915—Mr. John Buchan (*Times* and *Daily News*), Mr. Percival Landon (*Daily Telegraph* and *Daily Chronicle*), Mr. (afterwards Sir) Percival Phillips (*Morning Post* and *Daily Express*), Mr. Valentine Williams (*Daily Mail* and *Standard*), Mr. Douglas Williams (*Reuters*). Mr. John Buchan was succeeded by Mr. (afterwards Sir) Perry Robinson, Mr. Percival Landon by Mr. (afterwards Sir) Philip Gibbs, and Mr. Valentine Williams by Mr. (afterwards Sir) Beach Thomas. Mr. Douglas Williams was succeeded by Mr. Lester Lawrence and Mr. (afterwards Sir) Herbert Rudell.

At the beginning, the regulations for the guidance of correspondents were as follows, but for the most part they were allowed to write as they wished.

"Unless officially communicated for publication," the under-mentioned matters were not to be referred to:—

- Strength, composition and location of forces.
- Movement of troops and operations.
- State of supply and transport.
- Casualties.
- Important orders.
- Criticisms and eulogies of a personal nature.
- Moral of troops.

Before long, however, the regulations were rigidly enforced, and an attempt was subsequently made to strengthen them. A fresh set of rules was promulgated at G.H.Q. in Nov. 1915. They took this form:—

- (1) Current events must not be mentioned in detail until the events have been made public in the commander-in-chief's despatches.
- (2) Only general mention of the fighting can be made. Nothing outside the official communiqués is to be touched upon.
- (3) Matters of controversial or political interest must be excluded.
- (4) Praise or censure is to be left to the commander-in-chief.
- (5) Mention of any information by name is prohibited, including such items as the New Army, Territorials, etc., also names of units or individuals.
- (6) The articles of war correspondents must be confined to topographical descriptions and generalities.
- (7) Detailed information obtained by war correspondents can be used only when permission is given, and the time of publication will vary according to circumstances.

These regulations called forth an angry protest from the Newspaper Proprietors' Association. The War Office denied all knowledge of them and they were withdrawn. The severe restrictions on the liberty of the correspondents led to continual complaints by the Association. Notwithstanding these, no marked improvement took place until July 1917. From that date onwards the stringency of the censorship was gradually relaxed, and the army eventually set up an organization to supply correspondents with information, so that in dealing with the German advance in the spring of 1918 they were able to write with freedom. By the exercise of tact, discretion and inviolable good faith, the correspondents gradually won the confidence of the army, so that towards the end of the war officers of all ranks were keen to have them with their troops and to give them every facility permitted by official regulations. A

great victory was thus achieved and a great service rendered by the correspondents to the country and the Press.

Until Nov. 1917 the censorship was controlled by the Intelligence Department at G.H.Q. At that date it was transferred to a department known as Staff Duties. The difficulties were accentuated by the lack of association between the correspondents and the real head of the censorship at G.H.Q. The man who gave the orders did not censor the "copy," and was not in continuous and direct touch with those who did. The censors worked under great pressure, and the complaints were due chiefly not to their decisions, but to the principles laid down by those in command at G.H.Q. A minor difficulty was due to the necessity for making the despatches correspond with the daily official communiqué—the official account of the day's fighting. Nothing could be said by the correspondents that differed from the communiqués, which usually came out after the despatches had been written. The head of the Intelligence Department until Nov. 1917 was Gen. Charteris. During the whole of the war the chief cause of complaint was the refusal of the authorities to permit the correspondents to identify the units taking part in particular operations, or, in other words, to name the troops engaged. Where the unit was mentioned, neither the date of the event nor the locality in which it occurred was to be specified. The regulations in this respect were meticulous. Even obituary notices were censored. In the later phases of the war the rule was occasionally relaxed, but generally speaking it held until the Armistice.

At other military fronts than France the system adopted was similar, but special difficulties occurred in regard to the despatches from Mesopotamia, which were censored at the Front, in India and at home.

**The Naval Censorship.**—The navy had its own censorship department at the Admiralty, under the superintendence of Sir Douglas Brownrigg. This department worked partly through the Press Bureau and partly by direct relations with the Press. Generally speaking, the policy adopted was to suppress all information concerning the doings of the navy and allied forces and in particular events of an unfavourable character. Very little information was published concerning the mercantile tonnage sunk by the enemy. There was, however, much to be said for the suppression of these figures, the publication of which would have put fresh heart into the enemy and given them valuable information as to the effect of the submarine campaign. In many instances the German submarine crews were unaware of the effect of their operations.

**The Home Front.**—A rigid censorship was exercised concerning the publication of information as to the production of munitions, measures of defence, bombardments, air raids, arrests, trials and executions of spies, etc.

**Books, Magazines, etc.**—These were subject to censorship on the same principles as newspapers. In many cases the authorities refused permission to reproduce matter which had already appeared in American and other publications, whether true or not, the contention being that publication in England would tend to confirm and increase belief in the statements made.

**General Comments.**—As a method of suppression the censorship during the war may be regarded as having been a complete success. The vast task was well and efficiently done, but the authorities displayed little imagination, and during the first two and a half years failed to realize that the war was a conflict between nations, not armies. They did not fully appreciate that the united effort of all classes was essential to victory, and that such effort could be secured only by telling the people the facts and letting them know that the war was a matter of life or death to the nation (see PROPAGANDA). Experience showed that in dark days the country always rose to the occasion. The authorities also failed to appreciate the necessity for telling other peoples, and in particular the Overseas Dominions and America, what Great Britain was doing. When the war commenced the War Office and the army were full of explosive and inaccurate ideas regarding the Press. Lord Woleley had said that the special correspondent was the curse of the modern army. This spirit

pervaded the services during the earlier stages of the war, notwithstanding the voluntary action of the newspapers in suppressing naval and military information in July and Aug. 1914.

Maj.-Gen. Sir C. E. Callwell, who was the head of the Intelligence Department at the War Office when the war started, says in his *Experiences of a Dug-Out* (1920)—“It speedily became apparent that the ‘Powers-that-Be’ did not mean to be expansive in connexion with incidents where our side was getting the worst of it.” He also acknowledges that the Press was badly treated by the War Office and G.H.Q. at the outset and that he was placed in the uncomfortable position of administering a policy which he disliked and which he believed to be entirely mistaken. In short, the Press was regarded with distrust and suspicion. These feelings were gradually removed after constant protests, but not until the war had been in progress for nearly three years was a system evolved which by degrees gave the correspondents a reasonable amount of freedom. The rule prohibiting them, except in rare cases, from describing the achievements of the different units, who were thus robbed of the glory to which they were entitled, had most unfortunate results. The public yearned to know what the soldiers and sailors were doing, and the information was withheld from them. The Australian, Canadian and New Zealand censorships adopted a different system, so that the exploits of these troops were and are well known throughout the world. This led to the circulation of malicious stories to the effect that Great Britain was not doing her share, and that she was preserving her soldiers at the expense of those furnished from overseas. A reference to the terrible weekly casualty lists would at once prove the falsity of this statement. The truth is that so far as the British effort is concerned, the main burden was borne by troops furnished from Great Britain. Owing to the action of the British censorship, this fact is still imperfectly understood in other countries. The effects of the policy of silence were not confined to the war. Great Britain suffers from them permanently. In America and elsewhere the stupendous character of the British performances and sacrifices has been inadequately appreciated because they were not made known at the time. It is doubtful whether the people in Great Britain have fully realized themselves what they accomplished. During the war the Press was engaged in a continuous battle with the departments for more information. It was rarely possible to ascertain who was responsible for the policy of silence. The motives were laudable. What the authorities lacked was vision. The Press fully understood the necessity for secrecy in regard to forthcoming naval and military movements and also in reference to many naval and military operations. But there were other matters which might have been described had the authorities recognized the necessity for giving due publicity to what the nation was doing in the war. As already explained, the policy of secrecy was not confined to naval and military operations. It was only after continued protests by the Newspaper Proprietors' Association that publicity was given to the gigantic achievements of the Ministry of Munitions, and the manufacturers and millions of workers associated with it. Nothing was published about the marvellous working of the railways, one of the most remarkable feats in history. The Admiralty was a great offender. It was stated officially that “the Navy did not wish for publicity.” The result was that the wonderful British seamen, including the mercantile marine, mine-sweepers and fishermen, did not receive adequate recognition of their services to the Allies. After continued representations by the newspapers, more publicity was given to their doings in the later stages of the war.

It must, however, be recognized that the censorship bristled with difficulties. It was necessary to prevent the enemy from receiving information; it was necessary to avoid publishing information that would unnecessarily alarm British people or their Allies, or mislead neutrals as to the progress of the war; and it was also necessary for British censors to pay due regard to the censorship policies of other countries with whom Great Britain was associated. The authorities may be excused for their inability in the early days of the war to grasp the essential facts

of the situation, but they laid themselves open to severe criticism for the delay in realizing that a change of policy was necessary.

See Government Papers Cd. 7679 and Cd. 7680 (1915); Sir Edward Cook, *The Press in Wartime* (1920); Sir Philip Gibbs, *Realities of War* (1920); Neville Lytton, *The Press and the General Staff* (1921); Maj.-Gen. Callwell, *The Experiences of a Dig-Out* (1920); Sir Douglas Brownrigg, *The Indiscretions of a Naval Censor* (1919). (Rt.)

(2) UNITED STATES.—American Federal legislation in the matter of censorship shows nothing comparable to the British and French Government censorship of newspapers. The Federal Government had no traditions of censorship except the disastrous ones in connexion with the Alien and Sedition laws of 1798. The First Amendment to the Constitution stated that "Congress shall make no law . . . abridging the freedom of speech or of the press. . . ." There had been no sufficient number of cases before 1917 to afford a clear interpretation of this, except that it had been held to be as binding in war as in peace (Milligan case, 71 U.S.2). In the first weeks after the United States had declared war, Congress rejected an amendment to the Espionage Act that would have established a censor's bureau. Recognizing that a war involving the whole nation necessitated full information, the President established a Committee on Public Information on April 14 1917. This agency for publicity concerning war efforts and purposes developed into a great news agency and a means of distribution of patriotic propaganda. Its only direct relation to the control of the press was a request made by it in the name of the Secretaries of State, War and the Navy that newspapers censor themselves in the matter of news that might help the enemy or embarrass the Government. There was no legal force behind this. It was generally observed but with much grumbling and denunciation of the chairman of the Committee, Mr. George Creel, as a "censor."

The adherence of Congress and the President to the traditions of a free press and free speech in simply requesting a voluntary censorship was striking, but it was more in appearance than in reality. It seemed exceptional, for in addition to the usual reasons which justified the other belligerents in instituting official press bureaux and censors to control seditious utterances, the United States faced conditions unknown to them. It was the domicile of about 4,000,000 unnaturalized citizens of the Central Powers—"enemy aliens," to use an old and misleading phrase that was revived. In addition there were millions more born in those lands and using their languages, who had become citizens legally. During two and a half years of neutrality, the free and acrimonious discussion of the war and its issues had filled the Press, and been incessant in every home and community and school as well as in Congressional debates. The propaganda agencies of all the nations, and especially of the Central Powers, had flooded the mails, used the lecture platforms and organized their semi-official press. The country had heard much of the German espionage system, spies were suspected everywhere, and many acts of sabotage, arson, and violence in factories engaged in munition production were ascribed to them. The activities of German agents, some real and many imagined, seemed to call for vigorous action. In other respects, too, the United States departed from its old individualistic tendencies, as in instituting the draft, regulating food, raising huge loans, observing meatless days and sending an army of 2,000,000 to fight in Europe. That wise and necessary restraint did not more often give way to oppression and violence is amazing in a country where the frontier had but recently disappeared.

The fact that no new agency was established to control the Press did not mean that communication, the Press and public speech were to continue to be unrestricted. On April 6 1917, the day war was declared, the radio stations were taken over by the Department of the Navy under the law of 1912. On April 28 the President placed the cables in charge of the same department and the dispatch of messages and use of codes was strictly regulated. On the latter date the telegraph lines were placed in charge of the War Department but transferred later to the Post-Office Department when the Government took over the telegraph and express companies. Under the old Internment

Statute of 1798, the Attorney-General was authorized by the President to intern dangerous enemy aliens and by an Act of Congress the Alien Property Custodian assumed charge of enemy aliens' property.

So far Federal officials were acting under pre-war legislation including the old Treason law. The earliest war measures aimed at sedition and disloyalty had as a background the passage of the conscription or Selective Service law. It was a great venture in legislation for the United States. The possibility of interference with its enforcement was clearly in mind in the Espionage Act (June 15 1917), which provided that (Section 3, title 1): "Whoever when the United States is at war, shall wilfully make or convey false reports or false statements with intent to interfere with the operation or success of the military or naval forces of the United States or to promote the success of its enemies, and whoever when the United States is at war, shall wilfully cause or attempt to cause insubordination, disloyalty, mutiny, or refusal of duty in the military or naval forces of the United States, or shall wilfully obstruct the recruiting or enlistment service of the United States shall be punished by a fine of not more than \$10,000 or imprisonment for not more than 20 years, or both." The last of these clauses was the one oftenest invoked by Federal legal officers. Another section declared non-mailable all written or printed matter which violated any provision of the Espionage Act. This Act was not amended until May 1918 by the Passport and Sabotage Acts and the so-called "Sedition Law." The latter, a loosely drawn statute based on an Act of the state of Montana, sought to suppress all utterances of a disloyal character. It provided punishments up to 20 years' imprisonment for anyone who published "any language intended to bring the form of Government of the United States or the Constitution into contempt, scorn, contumely and disrepute." It opened the possibility for all kinds of complaints and prosecutions by those whose judgment was affected by war hysteria. The Federal Attorney-General, his assistant and the 88 U.S. district attorneys were flooded with silly complaints and beset by unofficial disloyalty hunters and amateur detectives, but kept their heads in most cases remarkably well, as did most of the judges. In the end no prosecutions were permitted until the Attorney-General reviewed the facts and gave authorization. The meaning of this statute was not interpreted by the Supreme Court until 1919, after the fighting was over. Not till then did the courts of first instance have a uniform and controlling indication that the relation between words alleged to be criminal and the armed forces of the nation must be direct enough to constitute "a clear and present danger." Before this, state and Federal courts had taken wide latitude in considering the "general tendency" of utterances. Men had been convicted for criticizing the Red Cross; doubting the utility of knitting socks for soldiers, using abusive and intemperate language in arguments about the war or producing such a motion picture as *The Spirit of '76* which in one part represented British soldiers using bayonets at the Wyoming valley massacre. The obsession that the country was full of German spies persisted until 1918, although Federal officers had broken up German espionage early in the war.

The prosecutions and deportations, especially those instituted by Mr. A. Mitchell Palmer, the new Attorney-General, were subjects of most bitter complaint as the war ended. Federal legislation was supplemented by Acts of even a more drastic character, in most of the states. Many of the state Acts on sedition bear date of 1919, i.e. after the close of the war and therefore subject to application and interpretation in fields quite unrelated to the nation's safety during war. In 25 states the display of a red flag was a specified offence. The other source of complaint against Federal activity was the judicially unreviewable power exercised by the Postmaster-General, Mr. Burleson, in closing the mails to journals of which he disapproved. This control was most often exercised by cancelling their classification as second-class matter entitled to low mailing rates. This virtual exclusion from the mails was continued to the financial ruin of some newspapers even though the objection was based on the material in only one issue. Much bitter comment (some of it



partisan) and discontent were aroused by the actions of the Postmaster-General.

So far as the foreign language press was concerned there were about 750 newspapers in the 14 chief language groups with whose attitude the Government was chiefly concerned. Most of these regularly published the official news from Washington concerning war activities and purposes. The President was empowered under the Trading with the Enemy Act (Oct. 6 1917), to require that translations of political views and comment touching the United States or any other nation engaged in the war should be filed with the post-office officials at the mailing point in the case of all foreign language publications. Exemption from this rule by special permit was allowed and freely granted. The Post Office Department was designated by executive order as responsible for the enforcement of these measures. In the same Act a very inclusive section gave the President complete power to control any form of communication to be delivered directly or indirectly to any enemy or ally of enemy, or communications of any sort between the United States and any foreign country. By executive order of Oct. 12 the enforcement of this was put in the hands of a Censorship Board composed of the Secretaries of War and the Navy, the Postmaster-General, the chairman of the War Trade Board and the chairman of the Committee on Public Information. This body made the necessary regulations and by Dec. 11 1917 had gathered a large staff at the necessary posts to enforce them. The regulations in no way modified the voluntary censorship exercised by the Press over itself.

About 6,000 out of 4,000,000 "alien enemies" were interned or put under restraint. In all, 1,532 persons were arrested under the Espionage Act.; about 75 more for threats against the President or for sabotage. There were 908 indictments for conspiracy. Acquittals and cases pending reduced the number of those actually convicted under the Espionage Act to about 600. The best-known case was that of Eugene V. Debs, former Socialist candidate for president, who was sentenced to 10 years in a Federal prison for a speech opposing the war and denouncing war as the work of capital. Others were the suppression of *The Masses*, a radical monthly, the cases of Abrams, Goldstein, Kate O'Hare, Berger, Rose Pastor Stokes, and the I.W.W. cases (Haywood and 92 others).

Beyond the realm of Federal action were the state laws, drastic in some cases, and the executive orders of some zealous governors and state defence councils who saw danger in speaking foreign languages in public or over the telephone, or teaching German in the schools, or using certain text-books. There was sometimes a lack of discrimination between the parties essentially loyal, representing agrarian or labour discontent, and those of their leaders whose purposes and sentiments were doubtful. There was also the sort of unofficial censorship, undefined by law but real, which communities exercised against those who had been pro-German or who were now less ready than their neighbours thought fitting to subscribe for loans and the Red Cross, and to observe food regulations.

On the whole, however, it is doubtful if all these legal and extra-legal activities in a nation of 100,000,000 were serious enough to justify any general condemnation of war legislation, the courts, and the nation. The quick reaction and sharp criticism of unfortunate acts and decisions indicated that free speech and free press were still basic ideals in the United States.

REFERENCES.—Official Bulletin (for executive orders); annual reports of the Attorney-General, Postmaster-General, etc.; Willoughby, *Government Organization in War Time and After* (1919); Creel, *How We Advertised America* (1920). Chafee's *Freedom of Speech* (1920) is a full and critical account with extensive bibliography. See especially J. L. O'Brian, "Civil Liberty in War Time" in *Proceedings of New York State Bar Association*, Jan. 1919.

(G. S. F.)

**CEREBRO-SPINAL FEVER** (see 18.130).—Although serious outbreaks of cerebro-spinal fever had occurred in Belfast in 1907, and in Glasgow and Edinburgh in 1906 and 1907, and although the deaths from cerebro-spinal fever in Scotland in 1907 reached 1,087, yet no considerable outbreak of the disease occurred in England or Wales until the first winter of the World War.

Cerebro-spinal fever had been made compulsorily notifiable in England in 1912, and in that year, in 1913, and in 1914, approximately 300 cases were notified in England and Wales each year.

In 1915 the disease increased more than elevenfold, there being 2,343 civilian and 1,126 military cases. In Feb. 1915 the outbreak indeed assumed very menacing proportions, and in a single week 228 cases were notified. Considerable alarm was aroused as the mortality was exceedingly high, and the serum treatment which had been so successful in the New York and Belfast epidemics appeared at this time to have little effect upon the mortality rate. Special investigations were therefore commenced by the responsible authorities (especially by the army with the assistance of the Medical Research Committee), which were continued during the war, and added greatly to the knowledge of the bacteriology and epidemiology of the disease.

Diminishing somewhat in 1916 the disease broke out with fresh vigour in 1917, military and civil cases being now about equal in numbers.

Actiologically, there can be little doubt that the outbreak in England which followed the birth of the new armies was principally due to the overcrowding of young recruits in depots, camps, and billets. It is also probable, although this has been warmly controverted, that fresh and highly virulent strains of the meningococcus were brought to England by the Canadian contingents arriving in the late autumn of 1914 after having had several cases of cerebro-spinal fever in their home camps before embarkation and during the voyage east on their crowded transports, and a sharp outbreak on arrival on Salisbury Plain several weeks before British troops were affected. These virulent Canadian strains may have aggravated the outbreak.

At Portsmouth, for example, the disease began on Jan. 25, 1915, at Eastney barracks among men who came in contact with a Canadian football team which visited there on Jan. 9, and the first case of the disease at Caterham depot occurred in a man who travelled up from Scotland by night with three Canadian soldiers in the same compartment.

The aetiology of cerebro-spinal fever is peculiarly instructive from the fact that, in at least 95% of all cases, the disease results not from infection derived from another patient suffering from the disease but from infection derived from an apparently healthy carrier, that is a person who harbours the meningococcus in his nasopharyngeal secretion without contracting the disease, and who is usually unaware of having ever been in contact with a patient suffering from the disease. Infection is most often transmitted in sleeping quarters.

Carriers are of two kinds: temporary carriers who harbour the meningococcus for only two or three weeks and who then become free spontaneously; and chronic carriers who harbour the germ for many months and even years.

Cleminson has shown that almost all chronic carriers have marked nasopharyngeal defects, the commonest type being that in which there is an obstinate mucous contact between a deflected and thickened nasal septum and the middle turbinate.

Chronic carriers are responsible for carrying on the disease from epidemic to epidemic and also for the sporadic cases which occur between epidemic times. Recovered patients are often chronic carriers, the meningococcus having been recovered after two years from the nasopharyngeal secretion in several instances.

In ordinary times the population probably contains some 2% of carriers, but at the height of an epidemic in a crowded community, such as that on a ship or in a crowded depot, the carrier-rate may rise to 75% the vast majority of the carriers being temporary.

At the outbreak of war the necessity for rapidly raising enormous forces at once led to very serious overcrowding of the available barracks and depots, and the hastily erected camps and hutments were overcrowded as soon as they were erected. Military necessity was urgent and imperative.

In Jan. 1915, all the known requisite factors for an outbreak of cerebro-spinal fever were present: severe overcrowding, cold weather, and a population rendered susceptible by youth, by the fatigue of rapid training, by nostalgia, and by entry into a new method of life.

Recruits have always shared with infants a peculiar susceptibility to cerebro-spinal fever. The armies in the field despite far greater hardship suffered much less than the recruits training at home. The incidence of cerebro-spinal fever in the U. S. training camps following their entry into the war was 45 times as great as that in corresponding male age groups in civil life.

Overcrowding has at least a threefold importance as a factor in the production of cerebro-spinal fever epidemics.—

First, the atmosphere of an overcrowded and ill-ventilated room or hut, by lowering the individual resistance, tends to favour the

chances of the meningococcus attacking the meninges with success. Secondly, by shortening the distance between man and man, overcrowding facilitates the transmission of infections of the upper respiratory passages, since these are present in droplets of secretion which are liable to be sprayed out into the surrounding air, in the acts of coughing, sneezing and loud speaking. For this reason, overcrowding favours the occurrence of catarrhal diseases, which so frequently precede and accompany an outbreak of cerebro-spinal fever. Thirdly, for a similar reason, overcrowding tends to produce a high carrier-rate of the meningococcus in a community; thus ensuring to any susceptible individual, freshly introduced, a massive dosage of the organism.

In addition, the rapid transmission from one temporary carrier to another which a high carrier-rate implies may very probably tend to increase the virulence of a strain of meningococcus previously of low virulence.

Glover's work on carrier-rates demonstrated that the meningococcus carrier-rate is a direct index of the degree of overcrowding, and that, when this overcrowding is remedied by increasing the distance between the beds, a high carrier-rate rapidly falls to a normal rate. There is a sharp rise in the carrier-rate of a community before an epidemic, that is to say, a "carrier epidemic" precedes and accompanies the "case epidemic." For practical purposes, a carrier-rate of 20% has been regarded as the danger line.

Cerebro-spinal fever is an acute infectious disease, due to the meningococcus. It occurs sporadically and in epidemics, and has usually as its chief manifestation an acute meningitis affecting both brain and spinal cord. The causal organism is undoubtedly the diplococcus intracellularis of Weichselbaum, a gram-negative coccus of characteristic kidney shape, almost invariably seen in pairs, and having no well-defined capsule. In the body fluids, and especially in the cerebro-spinal fluid, it is usually seen inside a polymorphonuclear white corpuscle. Often, however, the diplococcus is seen to be extracellular. Prognosis in a case is usually considered to be better when a slide of the cerebro-spinal fluid shows the majority of the diplococci intracellular rather than extracellular.

The meningococcus stains well, and is invariably gram-negative. An excellent culture medium is Gordon's tryptic agar enriched for primary culture with a solution of laked rabbit blood or fresh human blood. The optimum temperature is 37°C. The meningococcus ferments glucose and maltose, but not levulose or saccharose. Whilst it can be distinguished from other gram-negative diplococci by cultural tests, the best criterion for identification is serological, that is by agglutination tests with the sera of animals, immunized by repeated injections of killed meningococci obtained by culture from the cerebro-spinal fluid of patients suffering from the disease.

By the use of this method of agglutination and the allied method of absorption, Gordon divided the meningococci found in military cases of the disease in 1915 into four types. Dopter had previously differentiated two types, which he termed meningococcus and parameningococcus respectively, and the first two types of Gordon, which together account for 80% of the cases, correspond to Dopter's groups, Gordon's type 1 being Dopter's meningococcus and his type 2 Dopter's parameningococcus. Gordon's type 3, which is more closely allied to type 1 than to type 2, gave rise to some 15% of the cases, whilst Gordon's type 4 was of rare occurrence except in one outbreak at Chatham.

A patient suffering from cerebro-spinal fever harbours only a single type of meningococcus in his cerebro-spinal fluid and it is almost invariably present in his nasopharyngeal secretion. Determination of the type of the invading meningococcus is of great practical importance, as the serum of an animal immunized against one type has little or no therapeutic or protective value in a patient suffering from an invasion of a different type of meningococcus. A therapeutic serum must therefore either be polyvalent or if monovalent, be used only for its appropriate type when the type has been determined. For general use a polyvalent serum has the merit of simplicity and with potent serum the results are extraordinarily good.

Tallock has shown that type 2 is a complex type divisible into three sub-groups, and the much greater difficulty in producing a good anti-type 2 serum is probably owing to this fact.

Criticism of Gordon's types has concentrated mainly on his types 3 and 4, but there can be no doubt that Gordon's types were of the utmost value for the epidemic of 1915-8. In a series of 526 strains of meningococci from the cerebro-spinal fluid of patients, 98% were identifiable with one or other of the four types, and one-fifth belonged to types 3 and 4.

Infection of the nasopharynx probably always takes place first. In most cases a blood infection appears to precede the meningeal invasion, but the actual channel of infection between the nasopharyngeal secretion and the meninges is uncertain; it may be either through the blood stream, or by the sheaths of the olfactory nerves passing through the cribriform portion of the ethmoid, or by the sphenoidal sinuses.

The incubation period is usually three to four days. The onset is sudden and contrasts with the usually more gradual onset of tuberculous meningitis. In no disease is early diagnosis of more urgent importance. Intense headache, vomiting, a moderate degree of proxia with comparatively slow pulse, stiffness of the muscles of the neck and a positive Kernig's sign are the primary symptoms. The disease is usually well defined; these five symptoms being all present in 85% of cases, and only some 10% of cases are atypical, the most common deviation being a long initial pyrexia.

If there be any suspicion of the disease lumbar puncture should be performed at the earliest possible opportunity for the purposes of both diagnosis and treatment. Retraction of the head is a later symptom and should never be waited for.

The characteristic "spotted" rash is present in a percentage of cases, which varies considerably in different epidemics. Rashes appear more constant in American experience. In 1917 in London it was present in about 25% of patients; it is a macular rash appearing first on the skin and the dorsum of the foot, then upon pressure points, elbows, buttocks and back. Large purpuric patches are characteristic of fulminating cases, which form about 5% of the cases. Petechial maculae, erythema, rose spots, and blotches often occur in cases of ordinary severity.

Labial herpes is a later symptom than the rashes, and is of favourable import. Inequality of the pupils is less common than in tuberculous meningitis. Squint is seen in a smaller proportion of cases (6%) than in tuberculous meningitis. Hemiplegia, usually transient, and nerve deafness, usually permanent, each occur in about 5% of cases. Albuminuria is common, but usually transient; haematuria occurs in a small proportion, and, to a less extent, glycosuria. Constipation is almost invariable and with the incessant vomiting may lead to the diagnosis of an acute abdominal condition.

In children the disease is often ushered in by convulsions. Retraction occurs at an earlier stage than in adults. Persistent tetany of hands and feet is common and rapid emaciation occurs.

Three main clinical types of disease are described, fulminating, severe and atypical. A fulminating case is one in which the initial systemic invasion results in so profound a toxæmia that the death or early collapse of the patient may obscure the meningeal condition. Death may take place in a few hours after onset. Fulminating cases amount to some 5% and are more common at the height of an epidemic. Typical severe cases form some 85% of all cases and in them cerebro-spinal fever forms as clear a clinical feature as does any disease. Atypical cases form some 10% and the most usual form is one with a long preliminary pyrexia which may be diagnosed as enteric or trench fever. Ambulant or slight attacks do not occur.

The essentials of the treatment of cerebro-spinal fever are three:—

First, early and repeated relief of pressure by lumbar puncture; this procedure alone will considerably reduce the case mortality rate in adults. Secondly, the early and repeated intrathecal administration of a potent antimeningococcal serum (intravenous administration may also be beneficial if the systemic invasion be marked). Thirdly, the relief of pain.

Serum treatment depends for its success upon early administration, upon sufficient dosage and upon the therapeutic potency of the serum itself. The serum treatment of cerebro-spinal fever was introduced by Flexner and Jobling in the New York epidemic of 1905 with great success, and reduced the "untreated case" death-rate of over 70% to a "treated case" death-rate of under 20% in those patients who received serum in the first week of illness.

Unfortunately, at the beginning of the 1915 epidemic in England the only serum available proved very disappointing. It had been made from laboratory strains from previous epidemics, and had very little therapeutic effect. Subsequently it was found to fail to agglutinate type 1 and 2 at a dilution of 1 in 50. Following the collection of fresh strains from the current epidemic by Arkwright, Gordon, and others, however, a very potent serum was produced from them by McConkey at the Lister Institute in 1916, which again fully vindicated the value of serum treatment, reducing the mortality rate in cases where it was used in the first week to 14%. Gordon has shown that the therapeutic value of serum appears to depend chiefly upon its capacity of neutralizing the toxin of the meningococcus. There is great variation in therapeutic value even in batches produced by the same laboratory, although Gordon's modification of Besredka's method for determining anti-endotoxic content promises well as a method whereby a standardization of anti-meningococcal serum could be reached.

Owing to the complex character of type 2, it is harder to produce a serum satisfactory for all cases infected with this type than to produce potent serum for the other types. The monovalent type 1 serum produced by Griffith for the Medical Research Committee was extraordinarily effective for type 1 cases, but his type 2 serum was much less efficacious for type 2 cases.

Lumbar puncture, preferably under an anaesthetic, should be done at the earliest possible occasion. As much cerebro-spinal fluid, usually about 60 c.c., as will flow should be allowed to run from the needle into sterilized test tubes for culture and examination, until the fluid comes one drop at a time with each respiration. If the cerebro-spinal fluid be cloudy or purulent, 30 c.c. of serum warmed to blood-heat is then run in through the needle by gravitation with a rubber tube. The foot of the bed is raised after administration.

This procedure is repeated at intervals of 24 hours until four doses have been given, which are usually sufficient with a potent serum. The cerebro-spinal fluid becomes clear and free from meningococci. Often two or three doses are sufficient. It is often wise to conclude the series with a lumbar puncture without the use of serum for the relief of pressure only. Curative vaccines have been used, in prolonged cases, where serum appears to be losing its effect. An autogenous sensitized vaccine should be used.

Another method of treatment used in cases where the patient does not react well to the curative horse serum, or where no curative serum is available, is to inject intrathecally 30 to 50 c.c. of the patient's own serum, separated under strictly aseptic conditions from blood drawn from his basilic vein.

This procedure, based upon the fact that anti-bodies are developed in greater extent in the blood than in the cerebro-spinal fluid, has in some instances appeared to do much good.

Serum sickness on the 8th to the 10th day is often observed, but is not usually serious. Anaphylaxis is very occasionally seen. It is more liable to occur with intravenous than with intrathecal injection. The principal complications met with are pneumonia, the supervention of a pneumococcal meningitis, arthritis, cystitis due to the meningococcus, hydrocephalus, panophthalmitis.

In patients who recover, complete nerve deafness is the most common (3 to 5%) of the serious sequelae. Permanent mental change is unusual. A prolonged convalescence is essential.

The chief post-mortem findings in the majority of fatal cases are confined to the central and nervous system. Their macroscopic appearance is similar to those found in cases of other forms of meningitis. Fulminant cases may show little save injection of the dura mater, a lustreless arachnoid, a soft and swollen appearance of the brain together with a pink congestion of the pia mater. The cerebro-spinal fluid may only be slightly turbid in these fulminant cases.

The ordinary acute case shows a thick yellow purulent exudate mostly at the base of the brain extending along the main fissures, and down the cord. The bulb and the posterior surface of the cord are usually covered with marked accumulations of the exudate. Flaky and turbid fluid is found in the distended ventricles.

In chronic cases there is marked hydrocephalus. The convolutions are pale and flattened; localized adhesions and thickenings are marked between the membranes, thus forming pockets in the cranium and theca. The various foramina, particularly that of Majendie, may be obliterated, interfering with the circulation of the cerebro-spinal fluid. Marked emaciation is usual.

The post-mortem appearances in other organs are not usually striking. Embleton has shown the frequency of empyema of the sphenoidal sinus. A broncho-pneumonia is almost invariable. Purpura and other haemorrhages are common in many organs, and have been especially described by some observers in the suprarrenal capsules in fulminant cases. Arthritis, orchitis and pericarditis are described and a meningococcal cystitis may be found.

The chief point in the prophylaxis against cerebro-spinal fever is, of course, the prevention of overcrowding; this is of paramount importance. Ventilation and distance between the beds in sleeping quarters are of much greater importance than more floor or cubic space. "Wall space" is essential.

The early isolation of cases of catarrhal disease is of great importance in preventing the increase in the carrier-rate for the reason that a carrier with a catarrhal sneeze or a cough will spray the meningococcus in a much more effective manner than the same carrier without a catarrh. As a rule the meningococcus itself does not give rise to catarrhal symptoms in the carrier.

Where overcrowding is unavoidable and spacing-out impracticable, steam spray treatment, using a 2% solution of zinc sulphate, may be given for 10 minutes daily to the overcrowded community. In several instances this procedure appeared to check the incidence of cases during an actual outbreak of cerebro-spinal fever. This method of treatment should, however, never be used as a substitute for spacing-out and improved ventilation.

Prophylactic vaccination cannot be regarded as having been proved to afford protection, though at Salisbury and at Camp Funston it appeared to give promising results. (J. A. G.)

**CEYLON** (see 5,778).—The pop. had increased from 3,578,333 in 1901 to 4,110,637 in 1911 and was estimated at 4,757,598 on Dec. 31 1919, giving a density of 137 per sq. mile. The proportions according to race, per 1,000 of the total pop., were:—Europeans 1.5, Burghers 6.2, Sinhalese 628.3, Tamils 290.4, Moors 58.2, Malays 3, others 3.4. European residents numbered 7,349 in 1919. The death-rate was 35.6 per 1,000 in 1919—the highest yet recorded—and was mainly attributable to the influenza epidemic and an outbreak of cholera. The urban pop. represented about 13% of the total, the chief towns being: Colombo, pop. (1911) 211,274, Jaffna 40,441, Galle 39,960 and Kandy 29,451. Both immigration and emigration figures showed a general decrease—from 120,354 and 90,374 respectively in 1911 to 47,296 and 32,119 in 1917.

It is estimated that 2,182 Ceylon men (Europeans 1,373, and Sinhalese 609) joined the army during the World War and a further 1,204 were recruited for service as clerks and mechanics. The "Ceylon Sanitary Company," raised in 1917, rendered conspicuously valuable service in Mesopotamia.

**The Constitution.**—Under the constitution embodied in the Letters Patent of 1910, Ceylon was administered by a governor aided by an executive council of seven members, including the officer commanding, the colonial secretary, attorney-general, controller of revenue, colonial treasurer, Government agent of the western province, and one member nominated by the governor; and a Legislative Council of 21, including the 7 members of the executive, 4 other officials, and 10 unofficial members, of whom 4 were nominees of the governor and 4 elected to represent separate communities.

On Oct. 1 1920, with a view to giving a larger measure of popular control over administration, changes in the constitution which had been for some time under consideration received the approval of the King. The provisions were as follows:

As regards the executive council, the governor is instructed to appoint an additional three unofficial members; and, as to the Legislative Council, the modifications will (1) involve a considerable extension of the principle of popular election and (2) give the unofficial members a substantial majority over the official vote.

The reformed Legislative Council will number 37 members (exclusive of the governor who will preside), viz., 14 official and 23 unofficial members. Of the unofficial members, 16 in the first place and, as soon as arrangements can be made 19, will be elected by various constituencies—11 on a territorial basis (the franchise and qualifications for candidates following the proposals of the Ceylon National Congress), two to represent the European community, one the Burgher community, one the Chamber of Commerce, one the Low Country Products Association, and (until the registers for the Kandyan and Indian communities can be undertaken) two members will be nominated to represent these communities. Of the remaining four members, one member will be nominated (as before) to represent the Mohammedan community—it being thought impossible owing to the wide distribution of Mohammedans in the island to introduce any system of election for this community—and the governor will have power to appoint not more than three unofficial members to represent interests inadequately provided for.

By this arrangement, the unofficial members of the Legislative Council will be in a majority of nine over the official, but the governor will have both an original and a casting vote if he should choose to exercise it, and, in order to prevent a deadlock, it is provided that he may declare the passing of any measure to be of paramount importance to the public interest and, in such case, the measure may be carried by the votes of the official members. Somewhat similar reserve powers are contained in the Government of India Act.

The reforms have been opposed by certain sections and, in Oct. 1920, the Ceylon National Congress unanimously resolved to boycott the scheme as "utterly inadequate and reactionary."

For purposes of general administration, Ceylon is divided into nine provinces, presided over by Government agents. There are 3 municipalities and 21 local government boards. A Local Government bill, providing for a wide extension of the principle of local government was under consideration in 1921.

**Education.**—A new ordinance, constituting a Board of Education, which came into force in 1919, enacts that new regulations must be laid before the Legislative Council for disallowance or amendment before being confirmed by the governor in executive council. The board consists of not less than 16, or more than 20, members nominated by the governor, of whom the director and assistant director are *ex officio* members while the others hold office for three years. In 1919 there were 884 Government vernacular schools, with an attendance of 97,819 boys and 32,570 girls; 1,835 Government aided schools, with 129,027 boys and 78,849 girls; 256 aided private schools, with 9,261 boys and 1,247 girls; and 265 English and Anglo-vernacular schools attended by 36,526 boys and 10,462 girls—a total of just under 400,000. The total sum expended by Government on vernacular education in 1919 was Rs. 1,434,264 of which approximately two-fifths were spent on Government and three-fifths on aided schools. The total number of pupils attending secondary schools was 8,065 in 1919. The Government training college (1919) had 39 men and 41 women in training in the English side; 8 men in the Anglo-vernacular, and 40 men and 40 women in the Sinhalese. A scheme was on foot in 1919 for affiliating Ceylon University College to Oxford University. The building of a new Royal College was begun in 1920.

The strength of the force on Dec. 31 1919 was 2,388 of men. Statistics show an apparent increase of crime: there were 1,381 convictions in 1917, 8,328 in 1918, and 8,577 in 1919, the largest number of convictions in each year being for burglary.

Revenue and Expenditure during the five years 1915-9—the financial year ending Sept. 30—were as follows:—

	Revenue	Expenditure
1915	Rs. 51,545,475	Rs. 50,148,000
1916	60,611,025	56,104,515
1917	66,981,870	63,335,075
1918	63,933,628	61,944,549
1919	70,070,941	70,843,681

The principal sources of revenue in 1918 were: customs, Rs. 19,832,295; railways, 16,702,050; spirit licenses, 5,591,795; stamps, 5,733,985; port and harbour dues, 2,218,155; the salt monopoly; and sales of crown lands. Items of expenditure: railways, Rs. 12,746,895; public works, 8,218,935; interest and sinking fund on loans, 5,391,565; military, 4,668,060; medical department, 4,061,130; post and telegraphs, 2,878,419; education, 2,580,930. The area of crown lands sold decreased from 32,832 ac. in 1913, to 6,019 ac. in 1918, but rose to 6,456 ac. in 1919 in which year the system of outright sale, instead of leasing in perpetuity, was reverted to.

Public Debt.—At the close of the financial year 1919, the public debt stood at £5,142,268, or approximately one and one-tenth times the annual revenue.

Currency.—On Sept. 30 1919 the value of currency notes in circulation was Rs. 40,333,042. The Ceylon Savings Bank had a sum of Rs. 4,089,722 to the credit of 39,706 depositors on Dec. 31 1919, as against Rs. 5,152,980 and 37,099 depositors in 1911.

Agriculture.—It is estimated that about 3,000,000 ac. are under cultivation and 1,000,000 ac. under pasture. In 1918, coconut and other palms occupied approximately 1,226,000 acres, paddy 679,000, tea 506,000 and rubber 281,000. Livestock, in 1917, comprised 39,986 horses, 1,577,464 cattle, 86,103 sheep and 62,721 pigs. In 1919-20 considerable further areas were brought under paddy and dry grains in order to meet the serious shortage in the locally grown food supply then prevailing, while the area under rubber was reduced on account of the depression in the rubber market. Coffee, once a leading product, has practically disappeared from the list of exports.

A decision to restrict in 1920 and onwards, the production of tea by 20% was come to owing to the glut in the home market. Other Industries.—Sub-committees were engaged in 1920 in investigating the possibility of establishing paper and glass manufactures for which the raw materials are available in great quantity; and the development of the fisheries of Ceylon (at present in a very primitive state) was still being studied in 1921. The Public Works Department continued to investigate the question of hydro-electric production for the supply of electricity to industries and railways.

Communications.—The total mileage of railways was 728 in 1919, as against 712 in the previous year. The extension of the main up-country line by 21 m. to Badulla, the principal centre of the Uva province, was undertaken in 1920. The total length of roads was 4,086 m. of which 267 m. were mere bridle-tracks. At the end of 1919, there were 559 post-offices (including 160 telegraph) as compared with 444 in 1911.

Trade.—The following table shows the value (in Rs. 1,000) in 1919 as compared with 1911:—

	Imports	Exports	Total
1911	136,096	160,527	397,623
1919	239,324	367,055	606,379

The staple exports (values in lakhs of rupees) in 1919 were: rubber 1,321, tea 1,165, copra 323, coconut oil 257, desiccated coconut 239, and cinnamon 37. Of exports in 1919 the United Kingdom took 42.1%, United States 33.5, British India 6.8; and of imports British India sent 30.4%, Burma 23.9 and United Kingdom 14.2.

The following table gives in round numbers the exports of rubber and tea during the period 1916-9:—

	Rubber	Tea
1916	487,000	203,000,000
1917	446,000	195,000,000
1918	415,000	180,000,000
1919	900,000	208,000,000

Shipping.—During 1919, 4,130 vessels (including 1,018 sailing vessels) with a total tonnage of 9,988,176 (tonnage of sailing craft 1,203,153) entered the several ports of Ceylon. The distribution according to nationality was: British 6,467,584 tons, Japanese 1,051,331, French 317,776, Dutch 272,573, United States 87,499. The total tonnage entering Colombo amounted to 8,503,643.

CHAPPEE, ADNA ROMANZA (1842-1914), American soldier (see 5.800), died in Los Angeles, Cal., Nov. 1 1914.

CHAMBERLAIN, JOSEPH (1836-1914), British statesman, died at Highbury, Birmingham, July 2 1914. From 1910 onwards, as for the three or four years previously, after he had been struck down by illness in 1906, Mr. Chamberlain remained in the political background, personally crippled, but intellectually an

abiding source of strength to his old political followers, who continued to cherish his inspiration and to work for his ideals in the development of a united British Empire. Since they were now in opposition, the cause of tariff reform and imperial preference was no longer one of practical politics, and after the outbreak of the World War the conditions which had produced this active movement in 1903 were substantially altered. Nevertheless, it fell to Mr. Chamberlain's son, Austen Chamberlain, as Chancellor of the Exchequer in 1919, after his father's death, to include imperial preference in the budget of that year, and thus to carry this part of his programme to victory.

In 1916 Mr. Chamberlain's widow married Canon W. H. Carnegie, rector of St. Margaret's, Westminster, and chaplain to the House of Commons.

CHAMBERLAIN, (JOSEPH) AUSTEN (1863- ), English statesman, eldest son of Joseph Chamberlain (see 5.817) by his first wife, Harriet Kenrick, was born at Birmingham on Oct. 10 1863. He proceeded from school at Rugby to Trinity College, Cambridge, his father having determined to secure for the eldest son, whom he destined for politics, those academic advantages which early entrance on a business career had denied to himself when a young man. After a good degree at Cambridge and a useful apprenticeship in speaking at the Union, Austen Chamberlain completed his studies at the École des Sciences in Paris, and at the university in Berlin, where he attended the lectures of Treitschke. But valuable as this training was for the profession of politics, it was secondary to the advantages of daily contact with living issues which he enjoyed by growing up beneath the roof of perhaps the most compelling political personality of the day. He entered the House of Commons at a by-election in E. Worcestershire in 1892. He was returned again at the General Election in July, and in the following year, as junior Liberal Unionist Whip, he was to witness the slow slaughter of the Second Home Rule Bill after nearly 90 days' debate, in which Joseph Chamberlain was the protagonist. When Joseph Chamberlain became in 1895 Colonial Secretary under Lord Salisbury, his son became Civil Lord of the Admiralty. For five years, until 1900, Austen Chamberlain held this office, with Lord Goschen as First Lord; and although he was not called upon to speak often in the House, he succeeded in impressing his chief, and the permanent officials, with the integrity of his character and his solid grasp of mind. Wearing a single eye-glass like his father, and resembling him otherwise outwardly, critics would look for deeper resemblances too. But "Joe's" genius was his own; and Austen's strong gifts came to be recognized as none the less remarkable because they chanced to differ widely from his father's. The S. African War was virtually over when in Oct. 1900 the "Khaki" General Election took place; and upon Lord Salisbury's return to power Austen Chamberlain became Financial Secretary to the Treasury, with Hicks-Beach as Chancellor of the Exchequer. War finance explained the increased burdens of that year, and the 2d. rise in the Income Tax of the budget of 1902. But the most significant financial change appeared in the budget of 1902, when the 1s. a quarter duty upon imported corn was revived.

In the following summer Lord Salisbury resigned, and in the reconstruction following Mr. Balfour's accession to the post of Prime Minister, Austen Chamberlain entered the Cabinet for the first time as Postmaster-General. Peace in S. Africa had been declared; a season of reconstruction had now set in; and Joseph Chamberlain took advantage of the lull to visit the S. African colonies, so recently won and secured. It was on his return in 1903, only to find that a majority of the Cabinet had been converted in his absence to a remission of the tax on corn, which had been destined by him and his son as a weapon, however elementary, for forging Imperial unity—for by reducing it upon corn from the Colonies they had hoped to inaugurate a fiscal preference with the Dominions overseas—that the Tariff Reform movement was initiated by Joseph Chamberlain, with the result that in Sept., after launching the Tariff Reform League in the summer, he resigned from the Government. His son, however, joined the Cabinet as Chancellor of the Exchequer, technically a higher office than his father had ever held.

Although the Tariff Reform controversy raged throughout 1904, only faint fiscal ripples disturbed the new Chancellor's budgets of 1904 and 1905, which remained mainly orthodox. But the split in the Government and the party upon this paramount issue, together with other political causes (see 3.254), led to their crushing defeat in the election of Jan. 1906. Austen Chamberlain was again returned to Parliament. Subsequently in this year he married Ivy Dundas, by whom he had a family of two sons and one daughter. The Unionists had dwindled to 158, against 512 Ministerialists under Campbell-Bannerman, in the new Parliament, and the task of this disheartened residue was formidable. Austen Chamberlain, however, encouraged them, not only by his industrious activity, especially among the younger Tariff Reformers, in assisting the propaganda work, but in the House of Commons by his spirited assault upon the budget of 1906, as well as by his bold denunciation of Mr. Asquith's high taxation in the budget of 1907. In the year following, Mr. Asquith succeeded Campbell-Bannerman as Prime Minister, and his introduction of old-age pensions somewhat disarmed the critics of his finance. In 1909, however, Austen Chamberlain led the opposition against Mr. Lloyd George's "People's Budget." In a brilliant impromptu speech he moved its rejection, arguing that the Government was welding a weapon for oppressive taxation; and for 40 days in committee he fought it clause by clause and line by line, until the proposed diversion of the old Sinking Fund was dropped, the duty on ungoten minerals had to be jettisoned, and the land taxes were whittled down into weapons of such weak revenue-raising capacity that they finally vanished (with Mr. Lloyd George's assent) in his own budgets of 1910 and 1920. In the period of constitutional crisis which followed the Lords' rejection of the budget, and after the breakdown of his father's health, he consolidated his own position in the Unionist party as the leader of the Tariff Reform movement in his father's absence; and when Mr. Balfour resigned the leadership of the Unionist party in 1911 he had established strong claims to the succession. But another section favoured Mr. Walter Long, his senior, and it was characteristic of both men that they would not put the party to any division in the matter. Austen Chamberlain gave his full loyalty to Mr. Bonar Law when he was unanimously adopted.

In 1913 he became chairman of the Royal Commission on Indian finance and currency, acting until March 1914. When the World War broke out, it had not proceeded long before a Coalition Government became necessary, and he then joined the Government as Secretary of State for India. In this capacity he inherited extensive military commitments in India and the conduct of a campaign in Mesopotamia, over which distance gave him spasmodic and scant control. When difficulties overcame the expedition in its advance upon Bagdad, a commission was appointed to inquire into the causes in Aug. 1916. It reported in June 1917, and, since it reflected upon the medical preparations in India, a debate followed in the House on July 11. To the general astonishment Mr. Chamberlain in his speech announced his resignation, admitting the truth of the breakdown of the hospital arrangements, but explaining that he was entirely ignorant of it until the damage had occurred. Although the Prime Minister urged him to remain, he insisted upon the constitutional duty of a responsible minister to resign when his office had been censured, and in doing so he confirmed his reputation for disinterested and high-minded independence.

In 1918 he returned to office in Mr. Lloyd George's Coalition Government, as minister without portfolio. At the general election in Dec. he was returned unopposed for W. Birmingham, for which, on his father's death in 1914, he had been returned at a by-election, and he was then appointed, at Mr. Lloyd George's invitation, once more Chancellor of the Exchequer. The Peace was being negotiated in the early months of 1919 in Paris, but Mr. Chamberlain's valuable contribution to the deliberations there of the Supreme Economic Council, over which he presided, did not prevent the introduction by him of the budget on the last day of April, in a speech reflecting the gigantic pecuniary sacrifices of the nation and the urgent need for economy. Taxa-

tion was increased to meet an expected deficit; but the distinctive departure of the budget was the reduction of existing duties by one-sixth upon articles of general consumption from the Colonies. The principle of Imperial Preference thereby became an integral element of the British financial system; and by a strange stroke of fate it was thus first introduced by the son of the statesman who had sacrificed everything to preach this principle and convert his countrymen 15 years before. A little later in the year, although private pockets were empty and the spirit of sacrifice temporarily exhausted, Mr. Chamberlain issued the Victory Loan. In the budget of 1920 he had the titanic task of attempting to make revenue and expenditure balance, with a deadweight debt of £7,835,000,000 and a floating debt of £1,312,000,000. But not content with £150,000,000 in hand for debt reduction, Mr. Chamberlain called upon the nation for further efforts and increased the excess profits duty to 60%, while introducing a corporation tax for the first time. When he had taken office as Chancellor late in 1918 the budget could not be balanced without borrowing, and currency inflation continued. But in this, his second year, the budget balanced, over £90,000,000 of debt was repaid out of revenue, and inflation took a downward course. This was done when trade prospects were favourable, and before it could be realized that wide economic dislocation on the Continent, aggravated by home labour disputes, was about to create a profound commercial depression. Criticism was, however, not wanting in later months that a less drastic policy of debt reduction would have left citizens better able to finance business, and as the year went on some concessions had to be made to this view, with which was combined a growing agitation for economy so as to reduce expenditure. The withdrawal of the excess profits duty next year was announced in Nov. in advance of the budget statement for 1921, and Treasury control was everywhere tightened.

On March 17 1921 the political world was startled by Mr. Bonar Law's resignation of the Unionist leadership, owing to ill-health. Instinctively the party turned for a successor to the man who might have led them 10 years previously, and whose accumulated experience and services were now his overwhelming credentials. There were no competitors to Mr. Chamberlain's candidature; even the usual lobbying seemed absent; and on March 21, in a packed party gathering at the Carlton Club, he was unanimously chosen Leader of the party. As such he became Leader of the House of Commons, and took office as Lord Privy Seal, being succeeded as Chancellor of the Exchequer by Sir Robert Horne. (O. L. L.)

**CHAMBERLAIN, JOSHUA LAWRENCE** (1828-1914), American soldier (see 5.819), died at Brunswick, Me., Feb. 24 1914.

**CHAMBERS, CHARLES HADDON** (1860-1921), British playwright, was born of Irish parents at Stanmore, near Sydney, N.S.W., April 22 1860. As a boy of 15 he entered the N.S.W. civil service, but two years later sought a more adventurous life as a stock-rider in the Australian bush. In 1880 he first visited England, and two years later established himself there as a journalist, writer of stories, and finally as a playwright. Amongst his most successful plays (see 8.534, 536) may be mentioned *Captain Swift* (1888); *The Idler* (1890); *John-a-Dreams* (1894); *The Tyranny of Tears* (1899); *The Awakening* (1902) and *Passers-By* (1911). He died in London March 28 1921.

**CHAMPAGNE, BATTLES IN, 1914-8.**—At the end of the fighting after the battle of the Marne, the lines became stable along a front selected by neither of the opposing forces. On the sector W. of the Chemin des Dames, along the heights of Vailly Chavonne-Soupire-Moussy, the 6th French Div. had relieved British divisions, and its front line was, so to speak, hanging on to the slopes which dominate the Aisne, with the river in its rear, and with all its communications under observation of the Germans, who were holding the fort of Condé.

#### I. COMBATS OF 1914-5 ON THE SOISSONS-REIMS FRONT

*Vailly-Soupire, Oct. 30-Nov. 2 1914.*—On Oct. 29 the trenches occupied by the 6th French Reserve Div. were strongly bombarded on the plateau of Rouge-Maison; on Oct. 30 the 137th

Brigade was attacked with great violence; on account of the extent of its front it had no reserves and was compelled to retreat at 9 A.M. on the bridges of Vailly and Chavonne and to consolidate S. of the Aisne. On Nov. 1 the German patrols, which had pushed forward on the left bank, were driven off. On Nov. 2, however, at 8 A.M., after a violent bombardment the 138th Brigade was attacked in its turn and ceded one to two km. of ground, stopping the enemy advance in front of Soupir and Moussy. The 60th Reserve Div. suffered heavy losses: 78 officers and 3,800 men. This division was relieved by the I. Deligny Corps, which, during Nov. 6-12, failed to retake the lost ground.

*The Engagement of Crouy.*—On the heights of Soissons-Missy-sur-Aisne the French position was rushed forward too far to the N. of the Aisne. The 5th group of reserve divisions, which occupied this position, had even been compelled to leave the greater part of its artillery on the south bank, whence it was unable to support the infantry effectively. Fearing a repetition of the defeat suffered at Vailly by the 60th Reserve Div., Gen. Maunoury, commanding the VI. Army, decided to improve his position—a position which only hung on to the edges of the plateau which overlooked the Aisne. On his instructions Gen. Berthelot, who had just taken over command of the 5th group of reserve divisions, on Dec. 7, worked out a plan of attack on the Plateau 132, which dominates Crouy, with the object of debouching later on towards Terny with his left, then towards Pont Rouge with his right.

The attack on Hill 132 was launched on Jan. 5 1915 at 8:45 A.M., after a bombardment which lasted an hour and a-half. It was supported by artillery of various calibre, in which slow-firing guns of old type preponderated: 60 guns of 75 mm., 24 of 95 mm., 4 of 105 mm., 8 of 120 mm., 10 of 155 mm. (short), 4 of 155 mm. (long). This concentration represented a great effort at that period of the war, but it was insufficient, more especially as the French attack ended in a German attack, and the battle extended over a front of 10 km. Out of six breaches which the engineers were to have made in the wire with battens filled with petards four only were passable, but the others were opened by the attackers themselves. The four attacking battalions, drawn up in ten columns, seized the German trenches in a few minutes without great loss. All the German counter-attacks, preceded by violent bombardments, were repulsed during the two days of Jan. 8 and 9. On the 10th the French attack made further progress, but on the 11th the Germans succeeded in regaining a footing to the N. of Crouy.

On the night of Jan. 11-12 a flood on the Aisne swept away all the bridges at Villeneuve and at Soissons, except the "bridge of the English" at Soissons, so named because it had been constructed by the British army after the battle of the Marne. This unforeseen occurrence greatly hindered the sending-up of reinforcements and rations. The Germans had received considerable reinforcements in infantry and artillery. On Jan. 12, after a violent cannonade, they attacked Hill 132 and retook all the ground gained during the preceding days. Gen. Maunoury put at Gen. Berthelot's disposal the whole of the 14th Clés Div., one brigade of which was commanded by Gen. Nivelles. He wished to hold fast on his right with the 55th Div. and the composite Klein brigade whilst the 14th Div. should attack on the left towards Terny. But on the 13th his right was strongly attacked in the direction of Montal and Ste. Marguerite; these troops were very exhausted after six days of hard fighting without rest, day or night. Moreover, the 14th Div. had only made very small progress. The German artillery with direct observation could fire at effective range on the bridge at Soissons and disaster might follow its destruction. In these circumstances to leave French troops on the right bank of the Aisne was no more than a useless act of imprudence, and Gen. Maunoury gave them the order to retreat to the left bank. That retreat was carried out in good order during the night of Jan. 13-14, without being disturbed by the enemy. The losses totalled 161 officers and 12,250 men killed, wounded or missing.

On Jan. 25-26, after a very violent bombardment, which extended over several kilometres of front, the XVIII. French

Corps attempted a local attack, which, in consequence of the collapse of a dug-out which buried several hundred men, lost the crest of Hurtebise on the Chemin des Dames. Then the positions became fixed on this part of the front until the French offensive of April 16 1917. (C. M. E. M.)

## II. THE WINTER BATTLE OF 1914-5

The part of Champagne in which the winter fighting of 1914 took place consists of a vast, gently undulating plain between two ridges of hills and plateaus which form its northern and southern boundaries. The greater part of its surface is formed of white chalk covered by a crust of arable soil, often very thin and in some places non-existent. This chalky plain is in its southern part known as "dusty" Champagne, and in its northern part as upper Champagne. To the E. of it lies the hilly upland country bordering the Argonne, a clayey, broken district, covered with woods and well watered. Towards the N. the central plain is broken up by a series of small isolated hills, the principal of which are the hills of Brimont (170 metres), Berru and Nogent l'Abbesse to the N. and E. of Reims and that of Moronvilliers (260 metres) further to the E. To the E. the Champagne plain rises in like manner to the hilly zone of Rémois and Tardenois. Ever since the beginning of the 19th century attempts had been made to improve this impoverished land by planting pines in geometrically formed clumps, which form a prominent feature of the landscape. After some 25 to 30 years at least the pine needles decompose into a kind of crust, and it is thus possible to cultivate with some prospect of success. To the N. of the Marne the Champagne plain is traversed by several streams; the Vesle running north-westwards from Somme-Vesle to the E. of Châlons; the Suipe practically parallel to it running from Somme-Suipe to the Aisne near Condé en Suipe; the Tourbe flowing in the opposite direction and N.E. of Somme-Tourbe towards the Aisne at Servon; and the Dormois passing by Ripont, Rouvrois and Cernay en Dormois in the same direction. The Py and the Ailin flow respectively to the W. and to the N.E. between Breer, the Aisne and St. Martin l'Heureux on the Suipe. Several old Roman roads cross this region, notably those from Châlons to Reims by way of Souain and Somme-Py from St. Menchould to Vouziers along the valley of the Aisne, all running in a general direction from S. to N. They are crossed by the road from Reims to St. Menchould, which runs at the foot of the heights of Moronvilliers, Nogent l'Abbesse, and thence by St. Hilaire le Grand, Jonchery, Suipe and Somme-Tourbe. Villages are rare and of little importance; Souain, Perthes les Hurlus, Hurlus, Le Mesnil les Hurlus, Tahure and Massiges are all poor and ill-constructed hamlets scattered over the vast plain.

The winter battle began at the end of 1914. After the battle of the Marne the pursuit initiated by the Allied armies was checked after a few days, principally owing to a shortage of artillery ammunition, and the opposing forces took up position and set to work to construct extensive lines of entrenchments of a kind that had not been seen since the 18th century. South of the Aisne the German front swung round to the E. of Reims, included the hills of Nogent l'Abbesse and the forts commanding them, and ran thence along the Roman road S. of the Moronvilliers heights, crossing the Suipe above Auberville and passing S. of Souain, Perthes and Massiges and N. of Ville sur Tourbe to the Aisne. The choice of this line was not dictated by either strategical or tactical reasons. The two adversaries installed themselves in face of each other by means of a series of successive engagements, the German object being to maintain an unbroken front as close as possible to Verdun and Reims.

The French Higher Command considered that, despite the munitions crisis, the offensive must be resumed. The moral of the troops might well suffer from the wearisome hardships inseparable from trench warfare, for a kind of Siege of Sebastopol on a large scale appeared ill-suited to the temperament of the French soldier. Moreover, the "home front" had also to be considered; and finally it was necessary to do something to divert the enemy's attention from the Russian front. The British had opened their offensive sooner than the Germans had be-



lieved possible, and had thus contributed in no small degree to the victory on the Marne. But though this result had been achieved the first promise of their operations had not been fulfilled, and their initial success had been followed by a crushing defeat. It was thus of the first importance to hold fast on the western front as many as possible of those enemy troops who might be diverted eastwards if the situation there permitted it.

French G.H.Q. was, however, deceived with regard to the hostile situation. It was believed that the Germans too were suffering as acutely as the Allies from shortage of munitions, while the supposed losses in men and wastage of material were much in excess of the truth. All these causes contributed to Gen. Joffre's decision to adopt offensive policy, which was expressed in a general order issued to his armies on Dec. 17. "The hour for attack has sounded," it ran. "We have hitherto checked the enemy's effort; and now it is a question of breaking it and definitely freeing our violated national territory." It seemed as if a general offensive was to be undertaken on the whole front from the Swiss frontier to the North Sea; but as a matter of fact all that took place was a few isolated operations, notably in Flanders, Artois and Champagne.

The IV. Army, under Gen. de Langle de Cary, this time held the line between the V. and III. Armies from Marquiez farm near Prunay to a point between Boureuilles and Chalad in the Argonne. From left to right the front was held by the XII. Corps (to which were provisionally attached the 91st and 96th Territorial Div.), the 6th Reserve Div., the XVII. Corps, the Colonial Corps, and the II. Corps.

The operations began on Dec. 20 after a short artillery preparation, and although they were carried out on a wide front from Prosnès to the Argonne the results were not great. The offensive continued on the 21st and met with no better success. The XII. Corps lost heavily and was compelled to cease its attacks; the XVII. and Colonial Corps continued their efforts on Dec. 22, 23 and 24, capturing a part of the first German line at the price of numerous casualties. On the 25th the operations were suspended, and the enemy in his turn delivered a series of counter-blows which were repulsed. Towards the end of the month the IV. Army was reinforced by the IV. Corps from Picardy, which for the time being was held in reserve. At this period portions or the whole of eight enemy army corps (III., V. Armies) were opposed to the Allies in Champagne; from left to right these were a fraction of the VI., the XII. Reserve, the VIII., the VIII. Reserve, the XVIII. Reserve, a fraction of the VI., the XIII. and the XVI. Corps, besides Landwehr formations.

At the beginning of 1915 the situation was still very delicate in the Argonne, where the Germans reported every day captures of men and material, which French communiqués were unable effectively to dispute. This succession of minor checks could not fail to exercise some effect on the position in Champagne and to hinder Allied progress there. The enemy's resistance was very stubborn, and he passed from defence to attack on more than one occasion. Up to the end of Jan. the Allies continued the same monotonous series of small attacks in the Perthes-Beauséjour area, the net result of which was a small gain of ground to the N. of Beauséjour and Massiges. Continual bad weather and fogs then induced the command to order their cessation. By Jan. 15 the line had been pushed some 2,000 yd. to the N. of that held on Dec. 20; this had been effected after some 12 attacks and about 20 counter-attacks had been beaten off. In comparison with the terms of the general order for the offensive the smallness of the results achieved was striking, and the German High Command did not fail to use its opportunity of pointing this out, affirming that their opponents' losses on the whole front during this period were 26,000 dead and 17,860 prisoners, and the total casualties, including the wounded, 150,000 men at least, while their own losses were less than a quarter of this figure. It was stated that the German estimate of Allied casualties was 100% too large; but it seems certain that even so they were much in excess of those suffered by the enemy.

From Feb. 1 to 4 the front in Champagne became even more active; the French continued to progress slowly in the Perthes

district, but on the 3rd there took place three German counter-attacks, to the W. of that village, N. of Mesnil and N. of Massiges, and in the last-named alone they met with some success, breaking the French main position on a 2,000-yd. front, and capturing over 600 prisoners, 9 machine-guns and 9 guns of small calibre. On Feb. 10, by a misunderstanding, an isolated attack was delivered near Souain by the 6th Reserve Div. against Sabot wood; the enemy reconquered the lost ground in the afternoon and captured over 500 prisoners.

The general offensive which was to take place on this date was postponed to the 12th, and then to the 16th. The Russians had just been defeated in the Masurian winter battle, and their X. Army had been practically destroyed. French G.H.Q. considered it essential to assume the offensive on a considerable scale in order to hold fast the German troops on the western front; an easy victory was expected and Vouziers was given as the ultimate objective of the advance. On Feb. 16, 3,000 yd. of trenches were captured between a point N.W. of Perthes and N. of Beauséjour, with over 400 prisoners. The IV. Corps was held behind the XVII., ready to intervene. During that night ten German counter-attacks were repulsed; further progress was made on the 17th N.W. of Perthes, and prisoners were taken belonging to six different German corps—a singular mixture of units on so narrow a front. Two violent counter-strokes took place that night and the next morning between Souain and Beauséjour, but met with no success; five further efforts were equally repulsed during the night of Feb. 18-19. Fighting continued all next day, the advancing French troops meeting everywhere with stubborn resistance; they succeeded, however, in capturing a redoubt N. of Beauséjour, and another work N. of Le Mesnil. These partial attacks naturally proved unduly expensive in view of the results achieved; by the 27th the total of German prisoners taken since the 16th amounted only to 1,000, and the initial hopes with which the operations had been begun had thus in no sense been fulfilled. Meanwhile a new corps, the XVI., had been brought up from the Ypres area, and it was for the moment intended to use it in a new and powerful effort on the left of the battle front.

After the capture of the redoubt N. of Beauséjour on the 27th, units of the Prussian Guard which had recently arrived in Champagne delivered a night attack N. of Le Mesnil, but lost heavily and were defeated. French progress between Perthes and Beauséjour continued and by March the crest of the ridge parallel to the front of attack was secured. On the 3rd again the whole of the German trench system was taken to a depth of 1,000 yd. on a front of 6,000. On the 7th there commenced a series of attacks against a small copse—Sabot wood—which continued till the 15th; every day saw the same monotonous repetition of partial attacks and counter-attacks, every gain of ground being dearly purchased from the stubborn enemy.

On March 10 the German High Command announced that the winter battle in Champagne was virtually at an end, and that it had brought no change whatever as far as concerned the final result of the war. The main object of the French, to relieve the pressure on the Russians, had not been realized, any more than the proposed penetration to Vouziers. The Germans had made more than 2,450 prisoners; they had certainly lost heavily, more heavily even than in the Masurian battles, but still hardly more than one-third of the French casualties, which exceeded 45,000; and the new front in Champagne was more firmly established than ever. French G.H.Q. affirmed not less definitely, in a note issued on March 12, that the operations had attained all their objectives both local and general; the French had advanced to a depth of some 2,000 to 3,000 yd. on a front of 7,000 and had obliged the enemy to throw in reinforcements equivalent to a new army corps.

Both these assertions are disputable. The principal French objective, the relief of the Russian front, had been only imperfectly achieved. What were these 20-odd battalions diverted to Champagne in comparison with the masses engaged on the two fronts? Vouziers was still far off. The effect of the French attacks was greater than the enemy were willing to admit, it is

true, but they were out of all proportion to the sacrifices made. The truth is that the French methods had been found unsuited to the gaining of any real success; better artillery preparations, a larger scale of attack, not as hitherto a series of successive efforts on a narrow front, but an advance by large attacking waves along all the front of assault, and closer support of the infantry by the artillery, which should follow the advance and not remain tied to its first positions, were necessary.

The winter battle, however, was not yet over. On March 12 the offensive was resumed N.E. of Le Mesnil. By the 15th practically the whole of Sabot Wood was at last occupied. Operations continued in the next few days between Perthes and Souain, in the Perthes sector, N. of Beauséjour and N. and N.E. of Le Mesnil. Every foot of ground was bitterly contested, as witness the fighting for Jaune Brulé wood on March 18; but not till the 23rd did the French slacken their efforts. A letter of congratulation was addressed to the IV. Army by Gen. Joffre, and it was ordered to cease its attacks and consolidate its gains. One corps, the VIII., had alone lost close on 8,000 men, including 160 officers, between Feb. 16 and March 23.

Still the Champagne remained active. On April 8th, a violent German attack on Beauséjour redoubt was repulsed after an initial success. Thereafter the enemy had recourse in the Perthes-Beauséjour area to mine warfare, with its alternative of long delays and sharp assaults. In May the French operations in Artois, and those of the enemy in Galicia which brought about the large-scale Russian retreat, threw the course of events in Champagne into the background. The only action of importance was the German repulse on May 16 at Ville sur Tourbe, of which their first communiqué made so much. In fact an assault delivered by two regiments in close order, following on the explosion of three large mines, resulted merely in the seizure of a few trenches, which were speedily recovered by the French Colonial infantry, with heavy losses for the enemy. (B. E. P.)

### III. THE AUTUMN BATTLES OF 1915

After the offensive in Artois in May and June, activity on the French side was transferred to the Vosges and the Argonne, where local attacks were delivered throughout the summer, in the vain hope of confusing the enemy's ideas as to the point of delivery of the forthcoming offensive. At the same time preparations were taken in hand for an attempt in Champagne on a larger scale than ever before, and for a simultaneous and powerful diversion in Artois. The situation seemed to favour it. The increase in the British strength had permitted Field-Marshal French to extend his front; the French defensive system had now been so perfected as to allow of a reduction in the garrisons of quiet sectors and a proportionate increase in the reserves available. New divisions had been formed, and methodical instruction of the troops destined for the attack had been taken in hand. Finally there had been a great increase in the available supply of guns and shells.

In Champagne the object aimed at was nothing less than the complete rupture of the German lines on the front Bazancourt-Challeranges, so as to outflank their left N. of Reims and their right in the Argonne. It was also hoped, as before, to disengage the eastern front. The plan was to attack on a front of 25,000 yd. between the Moronvilliers hills and the Aisne.

The German defensive position, both in Artois and Champagne, consisted of a continuous front system, with several successive lines of trenches, and further back centres of resistance, themselves immense closed works, with a maze of trenches, capable each of holding out against assault. As a general rule these were some 2,000 yd. apart, but their exact situation was modified in accordance with the ground. This front system, comprising from two to five separate lines, and some 300 to 500 yd. deep, was followed by a second, traced on the ridge to the S. of the Py valley. It was carefully organized and provided with machine-gun positions and thick belts of wire sheltered on the reverse slopes.

At the beginning of Sept. the Germans had 70 battalions in Champagne, belonging to the III. Army (von Einem) and to the

50th Div., XIV. Corps, and XII. and VIII. Reserve Corps. During the artillery preparations which preceded the French attack they brought up 20 more (a division of the III. Corps, the 183rd Brigade, and half of the 43rd Reserve Div.), making in all 99 battalions on the first day of the battle. Ninety-three further battalions had to be put into line to fill up the gaps, so that their forces were practically doubled during the fighting; these were drawn either from the units at rest, such as the X. Reserve Corps, brought from Russia, or from the reserves of neighbouring sectors. In all, then, the Germans engaged 192 battalions. Their reinforcements came into line, not as large units with a view to being used for counter-attacks, but by small dribbles thrown in hastily as need arose; no doubt the command, fearing a break through, parried the danger as best it could by using these troops in single battalions or even half battalions. There thus resulted a regular "hotch-potch," to use Col. Feyler's expression, on Oct. 2, between La Main de Massiges (Hill 199) and Maisons de Champagne, on a front of 12,000 yd., of 32 battalions belonging to 21 different regiments. The 5th Div., for instance, had one regiment near Massiges, one battalion of another regiment near Tahure, and one of a third at Trou Bricot.

On the Allied side the arrival of a new British army, the III., in the Albert area, and the extension of the VI. French Army's front to the N., had rendered possible the transfer of Gen. Pétain's II. Army from Artois to Champagne. Under the supreme direction of Gen. de Castelnau it was to attack in conjunction with the right of the IV. Army under Gen. de Langle de Cary, and the left of the III. under Gen. Humbert, which was opposed by the German V. Army. On the left of the III. French Army, the V., under Gen. Franchet d'Espérey, faced the I. and VII. German Armies. The Allied fighting forces in Champagne numbered in all 35 divisions, or 420 battalions, at least, more than double the German forces engaged. So little effort had been made to keep the forthcoming attack a secret that, as early as Aug. 15, an order issued by Gen. von Dittfurth announced that it was expected; and on Sept. 22 Gen. von Fleck foresaw a "desperate effort" on the part of the French High Command.

Thanks to the efforts put forward to provide the French army with the heavy artillery and munitions it had lacked hitherto, the preliminary bombardment began on the morning of Sept. 22 and continued for three days and three nights without cessation, and was directed against the whole of the German front as far back as the second position. At the same time long-range fire was carried out against the hostile headquarters, billeting areas, and supply depots, and the Bazancourt to Challeranges railway. The effect was on the whole considerable, certain enemy units being left for 48 hours without rations as a result of the bombardment.

On the 22nd and 23rd the weather conditions favoured observations of fire, but on the 24th heavy clouds blew up. Next day, at 9 A.M., broke in rain, which lasted for several days. This had no little influence on the result of the battle.

At 9:15 A.M. (zero hour) the assault took place along the whole of the long front, and the first infantry waves, in an irresistible rush, broke into the enemy's trench system. On the left the attack was directed against a salient between Auberviv and the St. Hilaire-St. Souplet road; the first trench was taken but the attack was held up by uncut wire in front of the second line 1,000 yd. in rear. At the same time a counter-attack from Auberviv, supported by the fire of the heavy artillery on the Moronvilliers ridge, took the French in flank; the left was forced back but the right held its ground. This first phase was very short, and thanks to weak resistance the French suffered little.

The enemy had another strongly fortified redoubt E. of the St. Hilaire-St. Souplet road. Astride this road to the left of it the French infantry broke into the first hostile trench system, but were checked by machine-gun fire. To the right the assaulting units carried four lines of trenches, covered by belts of wire and sheltered in the woods, capturing 700 prisoners and 7 guns and penetrating the hostile lines to a depth of 2,700 yd. In the Souain valley, which marked the right boundary of the IV. Army area, the advance was pushed forward rapidly in three different directions; to the W. it reached the wood of William II., 2,000

yd. from its starting point, while in the centre in less than an hour it was seen to be approaching Cabaret de Navarin farm, over 2,500 yd. from Souain.

To the E. the Moroccan division (II. Colonial Corps) carried the first German line in the first rush and penetrated into the wood near the Souain-Tahure road. Parties of the 28th Div. (XIV. Corps) took part in this whirlwind attack. In 17 minutes they had reached Trou Bricot, more than 1,000 yd. from their jumping-off trenches; by noon they had passed the Souain-Tahure road and reached the slopes to the W. of this latter village, having advanced some 4,000 yd. and made considerable captures of material (10 guns were taken by a single regiment). At this point they reached the hostile second position, and which for the most part was sited on reverse slopes and was thus invisible save at a short distance. Before an attempt could be made to carry it a new artillery preparation was necessary.

In the Perthes gap French progress was quite as rapid. Two thousand yd. to the N. of the village the infantry reached the camp of Elberfelds, and captured some officers in their beds; they thus turned the left flank of the stormy redoubt N. of Le Mesnil; but the Germans held out in a switch trench for several days.

The XX. Corps attacked on the right of the XIV., the 11th Div. to the left, the 39th on the right and the 153rd in Corps reserve. The objectives of the 11th Div. were the Cuisines ravine and Le Mesnil hill, involving an advance to a depth of 3,000 yd. on a front of 3,000. After carrying these defences it was to push a further 4,000 yd. to the Dormois valley.

The first part of this programme was speedily accomplished but the right of the XIV. Corps, held up by uncut wire, left the flank of the 11th Div. in the air, and several enemy battalions, sheltered in two tunnels, running N. and S. under Le Mesnil hill, came out as soon as the French troops had passed on and fired into their rear; the left of the 11th Div. was thus enveloped and destroyed in a desperate fight against superior numbers. An attempt was then made to push forward the right and turn the hill on the E., but the reinforcements asked for arrived too late.

To the right of the 11th Div. the 39th had attacked, with its left moving on Maisons de Champagne. The crest on which this farm stood was taken and several enemy batteries surprised and captured. To the W., towards Bois Allongé, other batteries were rushed while in the act of limbering up. Further on two squadrons of mounted hussars intervened in a very unexpected manner; crossing the first enemy line despite a heavy barrage they debouched rapidly, attracting to themselves all the attention of the enemy, who to the number of 600 were then captured by the infantry who profited by the diversion caused by the cavalry.

On the extreme right the I. Colonial Corps was to capture La Main de Massiges, a complicated tangle of ridges, covered with trenches and dugouts. In the first rush the Colonial troops reached in 20 minutes the crater on the summit of Hill 191; the enemy counter-attacked but without success. The mopping-up of the captured ground was then begun and continued for several days. In the evening eight enemy trench lines had been taken, and on the Index, it was said, as many as nineteen.

Generally speaking the day had been highly successful, although at certain points the Germans still maintained their first positions. Almost everywhere the French had advanced some 2,000 to 4,000 yd., and Gen. de Castelneau believed that the road to Vouziers would soon be opened. But the French line was very sinuous, some units facing E. and some W. and the rest N. In the region of Perthes and Souain, Sept. 26 and 27 were devoted to straightening the line and in feeling forward up to the second German position on a 12,000-yd. front. The advance went especially well between Auberville and Souain, N. of the Roman road, where the VII. Corps did brilliantly. By the 28th the total area reconquered from Auberville to the western slopes of the Souain valley measured 16,000 yd. sq., and 3,000 prisoners and 44 guns had been taken.

To the E. the French troops succeeded in linking up, on the 27th, with those operating against Hill 193, W. of Tahure, surrounding and capturing a body of the enemy 2,000 strong; the camp of Sadowa and Hill 201 facing Tahure hill were taken also.

On the remainder of the front, as far as the Aisne valley, the pressure of attack continued by means of violent bombardments, bombing attacks and local offensives. But on the 26th the 39th Div. was driven from Maisons de Champagne, and a fresh attack by the 153rd Div. on the 27th in the same region only partially succeeded.

On La Main de Massiges the Germans received reinforcements drawn particularly from the XVI. Corps, and French progress henceforth became more difficult. None the less the I. Colonial Corps continued to advance between the 25th and the 30th. To the N. it reached Mont Têtu (Hill 199), and pushed down towards Ville sur Tourbe, capturing prisoners and material.

By Sept. 28 contact was made with the German second position on a front of 13,000 yd. from S. of St. Souplet and Somme-Py. Westwards the line bent back towards Auberville, which was still in enemy hands, as was also the hill of Le Mesnil and the neighbouring woods to the E. But progress towards Tahure and Ripont and possession of La Main de Massiges secured the envelopment of this last position on both flanks.

On Sept. 28 and 29 the French succeeded in setting foot in this second hostile position at certain points such as to the W. of Le Mesnil hill and Navarin farm. In this last sector they had even breached this line, but on such a narrow front that the enemy easily succeeded in preventing any further penetration. All hope of a break-through had disappeared. The V. Cavalry Corps, which had been brought forward in view of seizing any chance of exploitation, returned on the 28th to St. Remy, without even having gone into action. A general order dated Sept. 30 announced the close of the operations, the results of which included the capture of 25,000 prisoners of whom 350 were officers, 150 guns and a large amount of material of war.

On Oct. 6 the second German position was almost intact; the attack was held up in front of it in extremely difficult conditions; the French troops were in poor and half-finished trenches, hastily dug on bare slopes and exposed to flanking and enfilade fire. The attacks which continued till Oct. 8 were difficult to carry out and cost many men. Tahûre hill and the two Mamelles (Hill 187) N. of Le Mesnil were, however, taken, but Le Mesnil hill remained in enemy hands. Several attacks and counter-attacks took place at the end of Oct. and the beginning of Nov. without resulting in any material change in the situation.

According to Gen. Mangin the Sept. offensive in Champagne cost the French 80,000 killed and missing and 100,000 evacuated sick or wounded. It was therefore extremely costly, and one cannot say that the results achieved were in proportion to the sacrifices and efforts. The Allies had engaged in Champagne and Artois 52 French and 13 British divisions, more than were put into line at the battle of the Marne. These masses were supported by 1,300 French and 300 British heavy guns. The consumption of munitions by the II., IV., and X. Armies attained enormous proportions—3,980,000 rounds for the 75's and 987,000 for the heavy artillery. It was admitted that this last figure especially was too small for good results to be achieved; the Allied fire had been insufficient to destroy the enemy's accessory defences or the trenches of the second and third lines, especially on the reverse slope. Finally the front of attack, 25,000 yd., was not wide enough to prevent effective flanking fire.

In short, the offensive had not all the character of suddenness, rapidity and continuity that was desirable, and it went on too long, involving heavy losses without hope of decisive results. Thus there arose the conception of offensives with limited objectives, which when adopted as a general policy became fatal. In some quarters there became observable a tendency to adopt an even simpler method, that of "nibbling" at the enemy by partial attacks; it was forgotten that by this means the Allied troops used up their moral and physical strength at least as rapidly as that of their adversaries.

(B. E. P.)

#### IV. THE FRENCH OFFENSIVE ON THE AISNE, 1917

*Plan of the Offensive.*—The Allied plan of campaign for 1917 was drawn up, like the preceding one, at a conference which

assembled at Chantilly, on Nov. 18 1916, together with the commanders-in-chief, Joffre and Sir Douglas Haig, and all the heads of the British, Italian, Russian, Belgian, Serbian and Rumanian Missions.

The formation of new German divisions led it to be supposed that there would be a repetition of an attack during the early days of the spring, probably on the western front. It was therefore decided that active operations should be pushed forward on each front in every possible way compatible with climatic conditions. "In order to deny to the enemy the initiative in resuming operations, the Allied armies will be ready to make a joint offensive from the first half of Feb. 1917, with all the available forces at their disposal." The beginning of the offensive would be fixed according to circumstances and by common consent of the commanders-in-chief, who would maintain between themselves the "closest liaison." The Russian High Command declared its willingness to undertake the task of putting Bulgaria out of action; the Allied army in Salonika, brought up to a strength of 23 divisions, should cooperate. The mutual support that the Allies gave each other during the preceding year should continue, and the Franco-British and Italian staffs should jointly study questions of transport and the cooperation of troops.

General Joffre therefore drew up from Nov. 27 a general plan of attack. From Feb. 1 the French armies were to be ready to attack between the Somme and the Oise, at the same time as British forces between Bapaume and Vimy; from Feb. 20, the group of armies forming the centre would attack in their turn in Champagne between Pontavert and Reims.

The method of these attacks is detailed in instructions dated Dec. 16 and based upon experience gained both at Verdun and on the Somme. They were to take place on as large a front as possible, to aim at carrying the enemy's artillery positions in order to disorganize the defence by the capture of their guns, and to follow each other with the shortest possible delay in order to gain the whole advantage of any results obtained. The break-through was to be exploited boldly and vigorously; for it is the strength and rapidity of attack which ensures success. The tactical development, which must be indicated in operation orders, is to be realized by the grouping of forces according to the lie of the ground, the strongest forces being reserved for those sectors where progress can be most rapid. The preparation of attacks with artillery support is moreover studied in detail in these instructions; they indicate clearly, however, a change of method and consider the possibility of being able to break the enemy front by mass attack rapidly executed, carefully prepared and studied in its smallest detail.

The question of exploiting a successful attack is not forgotten, and its rapidity should embarrass the enemy and anticipate the arrival of his reserves; the attacks have a definite objective, but they are no longer forced to limit themselves to this objective.

M. Briand's Government strongly urged decisive offensive for the spring of 1917; political parties supported this. The effect produced on the public mind by the prolongation of hostilities and by a war of attrition was exaggerated; it was feared that German submarines would prevent the import into France of food and raw materials; lastly, the maintenance of combatant forces was, it was stated, becoming difficult. In the Chamber of Deputies the War Commission in Dec. handed to the Government the report of M. Violette supporting its conclusions: "If we are wise, we shall recommence active operations from the end of Feb. . . . the initiative in the great battle is a question of life or death for France."

It was in these circumstances that Gen. Nivelle took over the command of the French armies, in order to carry out the operations decided upon by the Allied Governments, drawn up by the Allied general staffs, and in which the plan of attack had been decided upon in general instructions issued by his predecessor. He considered that the front of attack might be slightly extended, and that there would be a great advantage for the progress of the offensive in Champagne in capturing the Chemin des Dames, a formidable position which overlooked the whole plain, and which assured him a bridgehead on the right bank of the Aisne.

Furthermore, the attack on the Somme and that on the Aisne must be simultaneous, and not successive, as in the original plan.

The Anglo-French offensive in the N. was to begin with a considerable straightening out of the British front.

Sir Douglas Haig was to attack Vimy with his I. Army, at the same time the III. and V. Armies should reduce the pocket left between Arras and Bapaume after the success of 1916. Following this, a concerted action should be undertaken in conjunction with the northern group of French armies, which was to operate between the Somme and the Oise. General d'Espèrey had relieved Gen. Foch of his command, the latter having been unjustifiably placed in disgrace after the battle of the Somme, the results of which were misunderstood.

On the Aisne the French offensive was to stretch from Vailly to Reims; Gen. Pétain, having been consulted by the new commander-in-chief regarding the offensive that had been planned, had very frankly expressed his criticism, which made it difficult to employ him in carrying out the operations. General Nivelle therefore entrusted their preparation to Gen. Micheler, who at this moment was strongly in favour of a lightning mass attack. The V. Army under Masel, which had occupied the front of the attack since 1914, closed up on its right in order to make way for the VI. Army, of which Gen. Mangin had just assumed command; the X. Army under Duchesne was held in reserve in order to exploit any success after the line had been broken.

The operation plans were drawn up for the various branches of the command according to the usual procedure. The general officer commanding, Gen. Nivelle, gave directions and indicated the form of attack; the commander of the group of armies, Gen. Micheler, fixed the objectives; the commanders of the armies, Masel and Mangin, shared the task amongst their army corps, and the instructions which were given to them were strictly limited to the rôle of their armies in the battle. It could not be otherwise, the commander-in-chief alone is in a position to conceive and draw up the plan of an offensive on a grand scale, as this presupposes a thorough knowledge of the general situation, of the possible cooperation of Allied armies, of the strength and resources of the national armies and of the enemy armies, as well as the instructions issued by the various war commissions—and finally of the intentions of the Government.

General Nivelle had decided on a smashing attack, aiming with the first assault to capture the enemy positions and the entire zone occupied by the artillery; this idea was in accord with the orders issued on Dec. 16 and signed by his predecessor, carried out on two occasions under his orders at Verdun. Such an operation appeared quite feasible, and no one raised any objection to it. He foresaw also, immediately after the break-through, the possibility of rapidly exploiting his success; the breach made would be immediately enlarged on both sides and the "armée de manœuvre" brought into action; "the later development of the operations having as its object to bring the main forces as rapidly as possible in a northerly direction: the main pivot Craonne-Guise."

General Micheler, in transmitting these directions, added that, in his opinion, the whole of the operations could be accomplished either on the day of attack or at the latest on the morning of the following day. As the objective to be reached he sketched a line passing to the farther side of the hills which overlook the north bank of the Ailette, reaching the plain of Laon to the N. and pushing in an easterly direction beyond the fort of Brimont. The first schemes of the operations called forth exchanges of opinion, as is always the case under similar circumstances. The only reservations were made by Gen. Mangin, who asked that preparations for attack, followed by this actual carrying out, should take place on several other sectors of the front, in order to obtain at the very least a relative surprise; he asked for exceptionally powerful artillery in order to shorten the period of preparation without endangering the actual task of destruction; and he added: "Seasonable weather is of great importance; march rapidly demands good going of the roads; the development of the operation would be assisted when the days are long and the nights clear. It is to be hoped that operations carried out prior

to the main attack will have denied to the enemy freedom of movement and initiative in attack, and that we shall be able to hope for the splendid day when we shall be able to bring into action our colonial forces." He pointed out to the commander-in-chief that, on a front of attack so difficult, without direct ground observation, it would be very nearly necessary to wait for fine days, when aerial observation is good and the ground hard.

These requests and observations were submitted to the High Command as an appreciation to be examined and compared with all others and to affect the final decision, which was the responsibility of the commander-in-chief alone.

General Nivelle never ceased repeating that it was necessary "to go on as far as possible" after the day of attack; Gen. Micheler fixed a first line to be reached in three hours and a second line three hours after. He went into too minute details which did not allow any initiative to his subordinate commanders; some differences arose which Gen. Nivelle had to smooth over.

To go on as far as possible implies that the attack continues until it encounters an obstacle which it cannot overcome without the help of new and methodical preparation; it is not by orders issued that the attack will be stopped, but by the action of the enemy; the High Command prepares itself to profit by the confusion brought about so often at various points of the field of battle, and, with this end in view, prepares its subordinates by pointing out very distant objectives. This is a principle second to none, and its application in 1918 brought victory to the French after giving the Germans their victories in March and May.

The necessity of foreseeing the exploitation of any success after a break-through is obvious; it was particularly evident in 1917. It was necessary to compel the general staffs and cadres of all formations to study the requirements demanded in a war of movement (which for a long time were lost to view), to think out the equipment of the foot soldier and the lightening of kit, the formation of columns, their march and supply, to decide upon the grouping of the heavy artillery which should rejoice in succession each army corps and army, to study natural obstacles, the network of roads, etc.

General Micheler obviously went rather far when he contemplated a threat on the enemy communications, "who would then be squeezed up between the Ardennes and the southern point of Holland," but this anticipation, realized in the following year, did not go beyond the general staff of the armies.

**Military Situation.**—The preparations for the offensive were in full swing when, on March 14, the withdrawal of the German line on the Hindenburg position commenced; this extended, on March 19, to the front between the Oise and the Aisne. The pursuit was immediate and vigorous. The Germans were hustled on to a prepared line, a line at which they had prepared to limit their withdrawal and to allow themselves time to organize at leisure the Hindenburg position. The completion of their field works, hampered by artillery fire, cost them considerable losses.

The German retreat had long been thought out and prepared. Only a small quantity of booty fell into the hands of the Allied armies. The evacuated zone had been systematically destroyed. It was not to be wondered at that all the roads of communication had been destroyed—that was war; to destroy inhabited places which could be used as a shelter for troops and which were near to the firing line is admissible, although this practice is straining severely the demands of war necessity. But to devote a large quantity of explosive to blow up stately ruins, like those of the castle of Coucy, and much manual labour to cut down the fruit trees—that is savagery.

It is essential to point out that important means of destruction were thus diverted from military use; by blowing up larger stretches of road, by felling a larger number of trees planted along their line of retreat, the Germans could have hindered to a great extent the advance and supply of the French troops. But not only against the Allied armies did the Germans wage war, but against the people of France, struck at in their past as in their future, in their artistic, industrial and agricultural wealth.

The plan of operations drawn up by Gen. Nivelle was necessarily modified by the withdrawal of the German line; the prepara-

tions in full course of execution of the army group under Franchet d'Espérey fell through, and on this front it was necessary to be satisfied with pushing the enemy in the direction of St. Quentin. But the British attack took up the greater part of its strength. On the Aisne, between Vailly and Neuvilette, the French attack retained all its power to operate; Gen. Mangin pointed out that during the withdrawal the German line had formed a right-angled salient in the direction of Laffaux mill and that an attack to the N. of this salient, directed vigorously, would take the Chemin des Dames in rear. General Micheler, commanding the group of armies of reserve, after some difficulty transmitted this suggestion to Gen. Nivelle, who accepted it and sanctioned the employment of two divisions. The remainder of his unattached troops were employed in a new attack to the E. of Reims on the Moronvilliers *massif*, which the IV. Army under Anthoine prepared to attack. General Nivelle calculated that the German withdrawal, which was a confession of weakness, only confirmed his desire to attack the German armies as soon as possible with all his forces. The modifications on the front of attack were sufficiently important, but on the whole he thought that they would improve a situation already favourable for an offensive.

**Political Complications.**—But two new events called into question even the principle of an offensive. On the demand of the German High Command, unrestricted submarine warfare had been decided upon by the Imperial Government, in spite of the formal declaration of President Wilson that the United States would look upon it as a definitely hostile act. All parties, even the most extreme, had approved of that resolution; the only reservation, entirely platonic, was made by the Socialists, and that was to throw the responsibility for it upon the Governments of the Entente who had rejected the German offers of peace.

The Central Powers faced the entry of the United States into the war with their eyes wide open; they calculated that their army would never be of more than very mediocre value and that its transport to Europe would be very difficult. The declaration of unrestricted submarine war was made to the United States on Jan. 30. On Feb. 3 President Wilson declared solemnly to Congress that relations with Germany were broken off; on April 5 and 6 the Senate and the House of Representatives recognized the state of war with Germany.

Almost at the same time the Russian revolution broke out. The Tsar Nicholas II., who had opened the Hague Peace Conference, and who had granted to his people their first franchise, suppressed alcohol, and, during the war, had shown himself to be a faithful ally whose help had often been invaluable, had fallen under the influence of the Empress, a German by birth; and she was under the control of the monk Rasputin and of German influences. The Tsar had become more and more detached from his people. From March 7 to 12, disorders broke out and grew in intensity; the provisional Government, which had been formed, collapsed with the imperial throne, and Russia fell into the hands of a power both erratic and weak, incarnated in the person of Kerensky. He proclaimed loyalty to the Alliance, but his military power appeared to diminish with the loss of discipline in the army. The Allies could no longer count on the Russian offensive scheduled for the spring.

Whilst this was going on, an incident took place on March 20 at a sitting of the Chamber which led to the resignation of the Minister of War, Gen. Lyautey, and, in consequence, of the Briand Cabinet. His successor, M. Ribot, chose as his Minister of War M. Painlevé, who, backed up by an important party in Parliament, had refused to enter the Briand combination because he disapproved of the nomination of Gen. Nivelle as commander-in-chief, because he was not in favour of that system of war which Gen. Nivelle, to his mind, typified.

M. Painlevé questioned those army commanders whom he presumed capable of being able to provide him with arguments against the intended offensive, but not the others. He increased their hesitation without even understanding it. These conferences took place without the commander-in-chief, who was informed by his subordinates but not by the minister. General Nivelle was also aware that a superior officer had been deposed at

the ministerial office to draw up a dossier against the offensive scheme, and he was disturbed about it. Nevertheless, none of the generals interrogated recommended that the offensive should be given up; they did not believe that it would lead to all the results foreseen by their chief, but they did not take the responsibility of advising its abandonment. Their opinion, therefore, was limited to absolutely sterile criticism.

On March 24, M. Painlevé also consulted Sir Douglas Haig and a number of British officers; without going into details of method, their unanimous advice was "to strike rapidly, with full force, a great blow at the enemy"; and he became convinced at the beginning of April, after the Russian revolution and the entry of the United States into the war, that the British were resolutely in favour of the great offensive.

It would have seemed that the Minister of War would be satisfied with that. But, on April 3, a conference took place at his instigation at the Ministry of War between M. Ribot, President of the Council, the Minister of War, the Minister of Marine Adml. Lacaze, the Minister of Munitions M. Albert Thomas, the Minister for the Colonies M. Maginot, and Gen. Nivelle.

The question for discussion was to examine if the offensive, the date of which was fixed for April 8, should take place in the new situation following the German withdrawal, the Russian revolution, and the entry of the United States into the war.

This conference, which took place five days before the date fixed for the offensive, was useless; it was unable to decide anything, unless it were the meeting of the War Committee to examine the same question—that is to say, if there was any reason to interfere with the British, in order to modify the plans drawn up in agreement with them and of which M. Painlevé had just learnt that they were firm supporters. Worried by questions concerning the way in which the attack would be unfolded, the commander-in-chief affirmed his unshaken belief in a rapid break-through, followed immediately by the foreshadowed exploitation which would, in the course of about three days, bring the group of armies under Micheler up to the Serre, 30 km. from his position of attack. In the course of the discussion, the necessity of destroying the first and second lines was pointed out, as well as the advantage of attacking when the weather was favourable.

It was decided that "the commander-in-chief should attack on the front which he had selected, at a time when he judged his preparations were complete, and on a day to be chosen by him." He had accordingly a free hand.

Everything appeared to be settled, and Gen. Nivelle free at last to prepare for the coming offensive, when Gen. Messimy, Deputy and formerly Minister of War, commanding one of the brigades which was going to take part in the offensive, approached M. Ribot, president of the Council, and handed him a report which, he said, expressed accurately "the opinion of officers of the highest repute in the French army and notably even that of the general who was to direct the coming offensive, Gen. Micheler." This report called for the immediate despatch of eight French and British divisions to the Trentino, and affirmed that only limited results could be obtained from the offensive and only at the price of important losses. The report said further that the order should be given immediately to wait for fine weather before beginning offensive operations in France, and in conclusion the commanders of groups of armies should be listened to, either singly or together, commencing with Gen. Micheler.

This report did not bring out anything new, and it was fatal as in the end the irresolution of the Government communicated itself to the subordinate staffs. It was sufficient, however, to bring about the assembly at Compiègne on April 6 of an extraordinary council of war; the President of the Republic, the president of the Council, together with the three Ministers of National Defence, the commander-in-chief and the generals commanding army groups, Micheler, Pétain, d'Espécy, were present. General Foch, who held the rank of commander of an army group, had been sent hastily the day before to Italy and was therefore not present. The Minister of War asked if the new situation did not modify the circumstances of the offensive. General Nivelle pointed out the necessity for an immediate offensive, carried

through to the end; the commanders of army groups were all of his opinion on this point, and Gen. Micheler, in direct contradiction to the memorandum which had brought about the war council, got up and said: "It is necessary to attack as quickly as possible, as soon as we are ready and the weather is favourable." All expressed however, in different ways, their doubts concerning an immediate break-through.

General Pétain was particularly explicit: there were sufficient forces to pierce the enemy front but not to develop success. General Nivelle thereupon said: "Since I am not in agreement with either the Government or with my subordinates, nothing remains for me to do except to place my resignation in the hands of the President of the Republic." Everyone then protested that it was impossible to change the commander-in-chief on the eve of an attack of which all had admitted the necessity, and Gen. Nivelle, after some hesitation, refrained from sending his letter of resignation. The net result was that the council of war broke up without deciding anything except the necessity of the offensive.

Before the commission of inquiry into the operations on the Aisne, which was called together in July 1917, Gen. Foch expressed himself thus: "Nivelle indeed acted thoughtlessly in accepting the invitation to be present at the conference at Compiègne; but I return to the point that the Government, having heard the opinions expressed at this conference, invited Gen. Nivelle to carry through the operations." General Pétain, having recalled the fact that he had pronounced an opinion unfavourable to the offensive, first to the Minister of War and later to the president of the Council, concluded by saying: "The Government, fully informed, took no notice. The chief responsibility therefore rests on their shoulders."

The report of the commission, which comprised Generals Brugère, Foch and Gouraud, is severe on the conference: "The doubt which had crept into the minds of the chief actors would not have been dissipated by the meeting on April 6. They did not give that mutual confidence and that belief in success which give to the commander-in-chief that energy and incentive that enable him to overcome events." The report records that there was no intervention taken to counteract the action of the commander-in-chief nor to weaken his orders, although the majority of those who met at Compiègne considered them as unrealizable. General Nivelle was allowed a free hand, with the reservation which was not clearly expressed, that if, after 24 hours of fighting, the results were indecisive and losses too heavy, the operation should be broken off. General Nivelle, however, reiterating his belief in a rapid penetration, declared that he did not wish to offer battle in half-measure, and that he did not know what form the struggle would take, once it was engaged. However, the two officers that Gen. Nivelle had taken with him to draw up the report had been dismissed and no written statement had been made. Everything remains, therefore, confused concerning this "extraordinary" council of war, the reason of the meeting, the debates and the conclusion. The memorandum of Gen. Messimy asked that the army group commanders might be consulted "either separately or together," but it did not ask that they should be confronted with their commander-in-chief before the foremost leaders of the State; it is necessary to point out, as well, a regrettable difference between this memorandum, which was based chiefly on the observations of Gen. Micheler, and the attitude of that general before the conference; all the army group commanders had been consulted by the Minister of War, at the instigation of Gen. Messimy, who had received satisfaction without being aware of it. The *raison d'être* of the conference thus vanished.

All the army group commanders considered that the offensive was absolutely necessary, and they thought that Gen. Nivelle anticipated from it results which it was not reasonable to hope for. They had spoken of this at the Ministry of War; they repeated it at the conference with different variations which, however, did not affect the essence of their declarations. With what object, then, to reproduce them? The Government are responsible for the general conduct of the war, but the commander-in-chief, their choice, has the command and the responsibility for the operations. The Government considered that the offensive was necessary and



repeated their view on April 3. If they no longer had confidence in the commander-in-chief—let them remove him. Even if this confidence continues or if it diminishes after a change of command on the eve of an attack, why take away so much of its chance of success by undertaking so hazardous a thing?

Assembled without rhyme or reason, this "extraordinary council of war" killed the confidence between the commander-in-chief and his subordinates, a confidence already affected; this ordeal, which had never before been inflicted upon a military commander, threw Gen. Nivelle into a state of anxiety, however impassive he might be before the enemy in battle.

*The Offensive.*—In accordance with the instructions of Gen. Nivelle, the British offensive commenced on April 9 before Arras and was continued until April 24 with great success.

It is true it had not effected a break-through but the advance was important and the booty taken considerable: 14,000 prisoners and 104 guns. The battle continued on this front. On April 14, the army group under d'Espérey had felt the Hindenburg line at the approaches of St. Quentin and had recognized its strength without being able to make any impression with the weak effectives available.

Fixed for April 12, postponed to the 14th and then to the 16th on account of bad weather, the offensive on the Aisne had been prepared in minute detail. First of all, it had been necessary to develop the lines of communication between the Marne and the Vesle and from there up to the front lines. A hundred and ten kilometres of ordinary gauge line had been constructed, 20 km. of metre gauge, 308 km. of 60-cm. gauge; 25 km. of cart roads and existing roads had been broadened on a length of 55 km. Twenty-two thousand men had been employed on this task. Four thousand five hundred tons of transport with an effective personnel of 28,000 men represented the automobile sections.

Forty kilometres was the front of attack; the VI. Army under Mangin, with a front of 15 km., consisted of 17 infantry divisions, one cavalry division and one territorial division; the V. Army under Masel, on a 20-km. front, consisted of 20 infantry divisions and one cavalry division. The VI. Army had 742 heavy guns, 846 field guns, 81 large-calibre guns, 594 trench mortars. The V. Army had 1,016 heavy guns, 860 field guns, 1,056 trench mortars, 91 large-calibre guns. The plan of artillery employment allowed quiet registration from April 2 to April 4, counter-battery work on the 5th and 6th; then the destructive bombardment commenced on the 7th and was to have been complete on the 11th; it was continued until the 15th, owing to the postponement of the attack. More than 3,000,000 rounds were fired.

The shooting, however, was hampered by rainy weather and by bad organization of the fighting planes, concentrated unfortunately with the army groups. During the too rare flying hours, the range-registering planes were not protected, and Gen. Mangin's urgent calls for their protection by fighting scouts met with no response. The VI. Army under Mangin had not been able to receive the number of short-range guns that had been asked for to destroy the Hindenburg line on its left, nor the long-range guns that had been asked for to accompany the attack on its right. Nevertheless, and in spite of what may have been said, the preparation was good on the whole and the *moral* of the troops had risen to the highest pitch. The Hindenburg withdrawal was rightly considered an avowal of weakness; the Russian revolution had removed a Court and a Government bound to Germany, and it was looked upon as an outburst both patriotic and liberal which recalled the dawn of the French revolution. The hesitations of the Government and of certain of the staffs had not had time to permeate the troops.

On the morning of April 16, the French infantry rushed from their trenches and captured the first German line on the whole front. The right and centre of the V. Army advanced two to three kilometres. The tanks, used for the first time, were detailed for the capture of the third enemy position; their unexpectedly slow progression left intact the observing posts of the Germans from which they directed the fire of their artillery on them; and owing to the too long distance which they had to cover they had loaded themselves up with extra petrol cans

which were set on fire by the shells. The infantry had not been trained to co-operate with them and profited little from their advance. They suffered heavy losses; in this first experience the heroism of their crews bought very dearly slender results.

The left of Masel's army was immediately stopped on the Craonne plateau. The 10th Colonial Div. of the VI. Army under Marchand captured the position of Urtebize with magnificent dash and some elements reached as far as the Ailette; but on the plateau of Craonne and Vaulcuer, the enemy machine-guns came up out of deep dugouts where they had remained under the shelter of the artillery. The struggle was very severe, and the detachments that had penetrated too far were taken in rear and compelled to retire. In the centre, progression was more satisfactory although difficult; the attack, stopped after an advance of between 500 and 2,000 metres, was renewed; on the left the set-off was good, but the advance was rapidly held and even thrown back at certain points on to its initial line.

The battle had not assumed the aspect foreseen, but continued. It was not the rapid and tremendous success anticipated, but it was success. As in all dispositions for attack, there is a tendency to block in front; the reserves in closing up to the front lines are liable to get bunched together and to come under enemy artillery fire, thus suffering heavy losses; in the VI. Army, precautionary measures taken in advance enabled them to remain on the left bank of the Aisne. In addition the counter-battery work had been most efficacious and had much allayed the effects of the enemy artillery. Machine-guns had stopped the attack. The system employed at Verdun under similar circumstances was immediately remembered, the centres of enemy resistance should be attacked, after having concentrated on them the fire of the necessary number of batteries, but the attack should be continued. This is less wearing for the attacker than for the defence.

On April 16, commencing at 10 o'clock in the morning, Gen. Micheler took all the heavy artillery of an army corps from the VI. Army under Mangin, then three sections of 155-mm. guns; in the evening all his reserves were taken away and his ammunition supply reduced. On the morning of the 17th, Gen. Nivelle visited the headquarters of the army group, where he was insufficiently informed of the situation, and then he took the decision of stopping the attacks of the VI. Army towards the N. and of pushing those of the V. Army towards the north-east.

This order was fortunately somewhat delayed in transmission, and on the 17th the attack continued actively on the centre of Mangin's army, with a very noticeable advance on the front Braye en Laonnois-Ostel.

As the pressure continued on the front Vauxaillon-Laffaux, the Germans could no longer hold in the pocket into which they had been squeezed and they gave ground. But the order of Gen. Nivelle commenced thus: "1. The battle fought yesterday clearly indicates the intention of the enemy to hold fast on the front of the VI. Army and to make difficult and costly in consequence the advance of your army to the north. . . ."

As the situation had changed, Gen. Mangin gave orders for a vigorous pursuit, which hustled the enemy and caused him heavy losses; the commander-in-chief approved of this action the following day. The fort of Condé was occupied. At the same time a very slow advance continued on the Chemin des Dames.

Commencing on the 19th, the IV. Army under Anthoine, belonging to Pétain's army group, had attacked the Moronvilliers *massif* and had secured important gains. The enemy counter-attacks were shattered on the 19th. Splendid artillery observation posts remained in the hands of the French. It was a limited success, but a very appreciable one.

From the 16th-20th, 21,000 prisoners and 183 guns had been captured in the French offensive; little progress had been made, but the advance of from six to seven kilometres, on the Aisne front of 12 km., resulted in the capture of a dozen villages, together with the fort of Condé and all the observation posts which overlooked the valley of the Aisne.

The railway from Soissons to Reims was fired. At last the evacuation of Laon began. *Moral* remained good at the front, excellent in the VI. Army, and the efforts of defeatist propagandists,

very harmful among the French public, had not yet begun to make itself felt in the army. In the meanwhile German exhaustion continued very fast. Of 52 divisions in reserve on April 1, 16 only remained unengaged. The anxieties of the German High Command could be seen after April 16 in the unusual nature of their *communiqués* which appeared to prepare public opinion for the worst eventualities. From that moment their *moral* declined rapidly. The results were not such as had been anticipated, but they were better than those resulting from previous offensives and had been gained with fewer losses.

The number, however, of these losses were greatly exaggerated by rumours which were circulated among certain classes in France and even in certain districts where no information could have come from the front. Enemy agents worked freely and with the connivance of the highest authorities, as certain trials before the High Court and Council of War subsequently showed. In addition to this numerous French deputies had followed the attack on April 16, either from Gen. Micheler's battle headquarters or from the lookout at Roncq. Their accounts spread amongst their friends who shared all their sincere feelings. It is necessary to have a great experience of war not to allow oneself to be unduly influenced by the flock of wounded who pour back to the rear at every big attack after the first day. Having raised alarm in the French Chamber, these accounts, mutilated and exaggerated, spread amongst the public, strengthening the effects of enemy propaganda. The enemy cleverly exploited this.

It was a regular Austro-German counter-offensive, perfectly organized, which turned the French success into failure. During the course of an operation both sides always exaggerate the number of their losses, which later information diminishes as soon as the situation becomes more clear; but exceptional reasons for mistake vitiated all calculations. Precise numbers of the losses were given, very different but all enormous. The first official estimate had been obtained through wrong calculation based on an average of men killed; this calculation was arbitrarily augmented by adding thereto the number of missing. In the second estimate the wounded were counted several times over owing to their passing through the hands of various medical units, to which were added the enemy wounded who had been treated in the French ambulances. When eventually the casualty lists from the armies did arrive the wounded amongst the colonial troops and the Russian brigade had been counted twice over, and that mistake (although proved by documentary evidence) was long maintained before parliamentary commissions by the French Minister of War, who made no attempt to calm the agitation. The rumour spread that the terrible losses were due to insufficient artillery preparation, that whole battalions had been thrown into the assault against uncut wire, that no precautions were taken for the evacuation of the wounded, and that numbers of wounded had succumbed through lack of medical attention. Scapgoats were looked for and guarantees demanded.

*Continuation of the Offensive in the Middle of New Complications.*—The commander-in-chief continued his operations in an atmosphere that became more and more hostile to him. However, the continuation of the offensive had raised no objections either at Compiègne on the 19th, when the French Minister of War came down to inform himself of his intentions, nor on the 20th at Paris, when Gen. Nivelle had been instructed to discuss matters at the Elysée. The X. Army under Duchesne had come into action between the V. and VI. Armies on the Craonne plateau.

General Micheler wrote on the 21st that the offensive undertaken to the N. appeared to him to require forces superior to those which he had available, and pronounced the opinion that it would suit him if he could limit himself to local attacks which he set out in detail. Gen. Nivelle ordered then that he should limit himself to the relief of Reims by carrying Brimont and giving more freedom on the heights of Moronvilliers, already captured, and at the same time to complete the seizure of the Chemin des Dames. Preparations for these two attacks began, but each one of them gave rise to characteristic incidents.

The operation on the Chemin des Dames towards Craonne led to an overture on the part of a young French deputy, who was

serving as an officer on the staff of one of the army corps detailed for the attack, to the President of the Republic, in which he pointed out to him the anxiety experienced by the generals entrusted with this operation. An exchange of notes between the Chief of the State and the commander-in-chief was the result and a consultation of generals summoned, an example of the regrettable discussion which was going through the Government and the High Command.

The intended attack on Brimont gave rise to direct intervention on the part of the minister regarding the detail of the operation. General Pétain, who was selected to carry out the newly created functions of chief of the general staff attached to the Ministry, received in his department the scheme of all the operation plans. M. Painlevé, whilst conferring with Gen. Masclé, commanding the V. Army, explained the detail of the operation against Brimont, and it seems that a misunderstanding arose between the two speakers regarding the probable number of losses. The scheme gave rise to conversations which lasted from April 22 to 29, and the minister instructed the commander-in-chief to suspend the attack on Brimont which the artillery had begun to prepare for. Generals Nivelle and Pétain were invited to discuss this question on the 30th, and the mutilated plan which appeared as a result of these conversations ended in the small attack of May 4 against two commanding positions. The French seized them, but they were driven off after losses which were really fruitless. Decisions taken affecting the direction of the French armies were the result of indifferent compromise between divergent wills, they were no longer commanded.

The British Government meanwhile, anxious regarding the results of the submarine war, were alarmed at the same time at the intentions which the French Government expressed.

Before the attack on April 16 they had learnt that the French War Cabinet intended to suspend the offensive at the end of a few days if the anticipated results were not attained, or at any rate nearly so. Also, as early as the 18th, Mr. Lloyd George asked Sir Douglas Haig "what would be, in his opinion, the effect produced if the French War Cabinet instructed Gen. Nivelle to cease offensive operations at a not-for-off date."

The noteworthy reply that Sir Douglas Haig made to this question on April 19 must be mentioned:—

"In my opinion the decision to suspend immediately the offensive operations, until such a time when Russia and America should be in a position to join us (probably not before next spring), would be most unwise. The struggle is following a normal course. Great results are never obtained in war so long as the enemy power has not been broken; and against an enemy both powerful and determined, operating with large effectives on a broad front, it is a matter of time and hard fighting." Sir Douglas Haig asserted afterwards "that the chances of success, this year, are remarkably good, if we do not relax our efforts," and he stated that "the future would confirm that forecast—that the suspension of the offensive would be more costly than the offensive itself." On the 26th Haig was called to Paris to confer with M. Ribot and M. Painlevé, who pointed out to him the enormous losses of the French army: 25,000 killed and 95,000 wounded, they said, when the real numbers, confirmed at this time by the casualty lists of the armies, were 15,000 and 60,000; they considered the necessity of stopping the offensive.

Before the members of the French Government Sir Douglas Haig maintained the view that he had expressed to his own Government; the results were not those that had been hoped for, but were such that he found them satisfactory. The German reserves were at this moment inferior to the Franco-British reserves; it was therefore necessary "to continue the battle to the end." On being asked a definite question by Sir Douglas Haig the members of the French Government replied that "the battle should be continued without modification of the general idea of the plan of operations drawn up conjointly."

The British Government became more and more anxious owing to the hesitation displayed by the French Government, and instigated two conferences which were held at Paris. At the first Gens. Pétain and Nivelle, Field-Marshal Sir Douglas Haig

and Sir William Robertson, Chief of the Imperial General Staff, met together. In reviewing the general situation they were forced to admit unanimously the absolute necessity of continuing offensive operations on the western front. A large part of the German reserves were exhausted, but if the enemy was given time to recover himself he would be free to attack either Russia or Italy with the greatest chance of success, and he would thus be able to hold on until the submarine war had obtained its full effect. In the new situation it was not a question of breaking the enemy front and of reaching at one blow distant objectives, but of exhausting the enemy's resistance. Once this object was gained "it was necessary to develop the results to the utmost possible."

The members of this conference were of the same opinion when they affirmed the necessity of fighting with all forces available, with the object of destroying the enemy divisions. "We are unanimous in thinking that there is no half-measure between that method and a defensive, which at this moment would be equivalent to a confession of weakness. We are unanimously of the opinion that our aim cannot be arrived at except through unceasing attack, with a limited objective." Allied staffs would determine methods and dates.

In the afternoon of the 4th the ministers of the two countries met at the Quai d'Orsay together with the members of the military commission. Mr. Lloyd George explained that he felt the need of persuading himself that all were quite agreed on the principle of the continuous offensive, the details of which were settled by the responsible authorities: "We prefer that the generals keep to themselves everything which concerns their plans of operation. When they are put on paper for communication to ministers it is seldom that the ministers alone see them. What we do not need to know is the precise locality of the attack, nor the date, nor the number of guns and divisions engaged. It is essential that these details remain secret. In England we do not ask these questions." He changed the preamble of the military commission into a formal pledge of the British Government, specifying always that the expression "limited offensive" was not to be understood as an attack by two or three divisions, but as an operation analogous to that which the British armies had just carried out before Arras. Mr. Lloyd George further insisted that, considering the situation with which both parties were faced, a serious and continued effort was absolutely necessary. He endeavoured to show the French Government all that had been done since the month of April: "We must not allow ourselves to underestimate the results of our offensive. Doubtless great hopes had been held that had not been realized. But if we did not *hope* for more than was possible perhaps we would not find that enthusiasm which was so indispensable in war."

He enumerated the captures: 45,000 prisoners, 450 guns, 800 machine-guns and 200 sq. km. reconquered. "Suppose that it had been the enemy who had obtained this success . . . and imagine the wave of pessimism that would have swept over the public. That is sufficient to show the reality of the success which we have gained. . . . The losses which we suffer are very painful, but it is impossible to avoid them if we wage war. . . . If it is a question of saving human life we say that feeble and repeated attacks cost as much as, and more than, wholehearted attacks. . . . I hope that these considerations will lead you both," addressing personally M. Ribot and M. Painlevé, "to admit that we must exert all our efforts at once."

The Prime Minister of England spoke in the forcible and virile language of a true statesman. Well informed of the situation in his own country, he sensed the value of time when it came to men and money. He understood war and all its exigencies, even the hardest; he was capable of the high direction of war because he knew how to govern the expert without entering into the detail of his technique. Mr. Lloyd George took with him to England a written promise, but it was wrapped round with such reticence that he could not have had many illusions concerning the duration of the attack "*sans répit*" to which the French Government had just pledged themselves.

Whilst the British offensive was in full swing on the Scarpe the struggle continued in Champagne on the Moronvilliers

*massif*; a violent German counter-offensive had been repulsed on April 23 and the IV. Army under Anthoine seized Mount Cornillet. The Craonne *massif* was seized on May 4, and the mill at Laffaux on the 5th, together with a whole series of positions which the German counter-attacks failed to retake; it was a good success, but it should have been completed by advancing to the Ailette, for the X. Army held on to the crest with difficulty, where it suffered for many weeks heavy losses, which were due to the suspension of the offensive and not to the offensive itself.

The results of the Franco-British offensive were 62,000 prisoners, 446 guns and 1,000 machine-guns taken; the French armies had lost, April 16-25, 15,000 dead, 60,000 wounded and 20,500 missing. On the whole front of attack the advance was carried far enough to force the enemy to reconstruct his battle-line on an 80-km. front; important positions remained in the hands of the Allies: the Vimy crest, the Laffaux mill, the fort of Condé, the Chemin des Dames, and the Moronvilliers *massif*. Railways of great strategic value were fired. If to these gains be added those resulting from the withdrawal in March, obtained by the mere threat of attack, the first months of 1917 represented for the Entente a total of very valuable successes.

The total of German losses had not been made known, but it can be estimated approximately by basing it on the number of divisions which were engaged on the attacking front. On April 1 43 divisions were in reserve in rear; nine were *en route* for the French front, two coming from the eastern front and seven being newly constituted. The German armies had therefore 52 divisions available. On April 22 this figure was reduced to 16; on April 25 to 12; on May 4 all their divisions had been engaged. It was necessary to draw on the quiet sectors in order to maintain the battle. At first, divisions withdrawn from the front could, before returning to the line, take a few days' rest and refit. This soon became impossible. This wear and tear increased to an unbelievable extent; the remnants of troops withdrawn were thrown, without transition, on the Argonne front or on the heights of the Meuse. The 11th Guards Div., for example, cut to pieces from May 5-10 on the Californian plateau, was identified on May 18 in the Argonne; and the 28th Div., relieved on the 18th, was identified in front of Verdun on the 28th. These divisions' only rest was during the time of their displacement. The same statements are made as concerns the English front; all goes to confirm the extreme wear and tear of the German army.

On May 25, 99 divisions had already appeared on the front, amongst which 11 had appeared twice; there had been as well 110 divisional movements. But now the number of German divisions which took part in the battle of Verdun in 1916 was 43 in 20 months; in 3½ months 137 divisions had fought on the Somme. In 1917 the wear and tear was thus treble.

It is quite true that Gen. Nivelle had not obtained that breakthrough which he had hoped for, but thanks to the length and vigour of the attack the exhaustion of the enemy was very near to attainment. The Allies were in a position to profit by this, because, at the moment when the German reserves were entirely used up, 30 divisions remained intact on the side of the Entente: 16 French and 14 British. As the Germans had a total of 150 divisions on the Anglo-French front, as against 178 Anglo-French divisions, the system of reliefs was much more favourable for the Allies. One can understand then why the British Government and High Command insisted on the continuation of the attack.

But were the French troops in a state to repair their losses and to continue the offensive?

On April 1 1917 the French armies on the front consisted of 2,905,000 men, a figure which had never been reached before. In order to keep up this figure the 1918 class was available, and those that had not been called up from the preceding classes, which might be put down at a total of over 300,000 men for the coming year. Besides, during that very year, after the release began from all the war factories, more than 700,000 men were taken from the front for work in the interior in spite of the protests of Gen. Nivelle, and later of his successor Gen. Pétain, who, in order to arrest this excursion to demobilization, had to threaten his resignation. The suspension of the offensive was inexcusable.

Ludendorff confesses now his qualms: "Our consumption of troops and of munition had been extraordinarily high. We were not able to foresee what would result from the fighting or what efforts we should be called upon to make." He attributes his safety in the spring to Russian inaction during the Franco-British attack, and in the summer to French inaction. "As I reflect, and imagine that the Russian success had been gained in April to May instead of in July, I do not see how the High Command could have been able to remain master of the situation. . . . The Russian offensive came too late, in July, two or three months after the beginning of the Franco-British offensive; there was no concerted Allied action, as in autumn 1916; each went his own way and we were able, acting as we were on interior lines, to repulse and defeat separately our adversaries who were not working in conjunction." And, in fact, six German divisions were taken from the French front in June 1917, which contributed to a large extent in stopping Brussilov's offensive. It is true that the French Government was not in a position to cause the Russian army to act; however, the continuation of the French offensive would have produced the same effect in using up the German forces, and it is, moreover, quite certain that it was possible to attack again in July the German front, weakened as it was by these previous deductions, and, in consequence, to arrive at the final result foreseen by Ludendorff. In May 1917 the German army was in a condition which only occurred again in Aug. 1918; but then the Entente knew how to profit by it.

The French Government had in their service at Rechezy, near Belfort, a most perspicacious intelligence agency, under the direction of Dr. Buchert, which being as it was on the borders of Switzerland and Alsace-Lorraine made use of the most varied sources of information. This information, now published, testifies to the great anxiety of public opinion in Germany. M. André Hallays, who was stationed there, thus expresses himself: "On reading the German newspapers of the latter half of April it is impossible to make any mistake; behind the line everyone had then the feeling that the armies had just suffered a series of heavy set-backs before Arras and on the Aisne. Whilst at home a wave of pessimism swept over the country and the madness of certain politicians pervaded the Government, the press and the public; whilst false-rumour mongers, exaggerating the importance of our losses and the seriousness of certain mutinies, exerted themselves to give to France the impression of defeat—whilst this was going on the German staff found itself obliged to multiply reports and comments in order to reassure the dismayed Germans." These attacks had come as a terrible surprise to them. When the strategic withdrawal took place had it not been promised that "tremendous events" would result from that "stroke of genius"? Had it not been inferred that the areas so carefully devastated would become the theatre of a new offensive? And now it is the armies of the Entente who assault the German positions, capture thousands of prisoners and threaten new positions! In vain the *communiqués* sang of victory; in vain the military critics announced that, thanks to "an elastic withdrawal," the High Command had saved the blood of the soldier, that the attempt to break through had failed, that the *communiqués* of the Entente were a tissue of lies, and finally that Hindenburg and Ludendorff knew how to husband reserves and to retain the initiative.

Public opinion, preoccupied by strikes, remained insensitive to these consolations, and was only struck with the enormity of the losses. From May 1, after the threat of revolution was definitely dispelled, news coming from France was read with more attention. Extracts from Paris papers were telegraphed by agencies, the accounts of debates in the French Parliament were noted; the enemy himself was proclaiming his defeat. The press bureau hastened to take advantage of the innumerable signs that the adversary showed of his discouragement. They persuaded Germany that she had just gained "a great defensive victory." Thus they succeeded in wiping out the disastrous impression which prevailed after the battles of the Aisne and in Champagne; nevertheless a "defensive victory" was not what the people expected; success of this nature did not bring the date of peace any nearer.

The French Government, however, shut its eyes to information which contradicted its preconceived opinion, whether it came from the French or British staffs, from the British Government, from French agents abroad or from the German newspapers. French public opinion, left without information or guidance, was more and more worked upon by enemy agents. "Treason stalks freely abroad," said M. Galli in a report to the military commission in the Chamber; "from the lobbies of the Chamber, from the anterooms of ministers, the most foreboding rumours of discouragement ooze forth." Scapegoats were sought for; on the 27th, on this same commission, the French Minister of War was called upon to censure Gen. Mangin, around whose name had been conjured a very tissue of lies which a few months later had to be refuted by those of his colleagues who had arrived at unjustifiable conclusions. Yielding to pressure, which he believed at the time to be irresistible, the French commander-in-chief asked the Minister of War verbally that Gen. Mangin might be relieved of his command. The French council of ministers, taken unawares by the Minister of War before any report or written request had been made, agreed to this on the 29th, and it was quite useless that M. Painlevé became convinced that very evening that none of the charges brought against the general commanding the VI. Army could be justified. A later correspondence conducted between the commander-in-chief and the Minister of War cleared the position of Gen. Mangin.

The authority of the commander-in-chief had not ceased to be diminished after the arrival of M. Painlevé at the Ministry of War. This authority, impaired by the conferences of ministers with the army group commanders, further shaken by the conference at Compiègne on April 6, the echoes of which still resounded, had been killed by the way in which the functions of the chief of the general staff were exercised, functions delegated to Gen. Pétain, who, moreover, had been selected with his assent. The commander-in-chief was unable to order an attack, however small it might be, without being compelled to submit all the details to a general who had openly found fault with all his operations and who appeared to be his successor designate. The *crise* concerning the command had been no secret for a long time, but it was on May 9 that the President of the Council announced it to the military commission of the Senate; the following day, at the French War Cabinet, the Minister of War asked Gen. Nivelle to offer his resignation under any protest which he liked to choose. Considering that a change in the French High Command would be regarded by the enemy as a confession of defeat Gen. Nivelle refused to hand in his resignation, and hesitation on the part of the Government lasted several days. The threat, however, of resignation by the Minister of War and the attitude of the President of the Council determined the council of ministers to relieve him on May 15 by appointing Gen. Pétain. General Foch succeeded as chief of the general staff.

*The Battle of Malmaison, Oct. 23-26 1917. Evacuation of the Chemin des Dames by the Germans, Nov. 2 1917.*—The hesitations which had succeeded the offensive of April 16 on the Chemin des Dames had cost the French much more dearly than the offensive itself. The German line formed a right-angled salient at the Laffaux mill—and the safety of the position to the S. of the Ailette depended on its possession—for which the two combatants had so hotly contested in May. The battle had slackened in intensity in June and gradually died away in July. Called upon to prepare an offensive with limited objectives at this front, Gen. Maistre, commanding the VI. French Army, had fully realized, since June, that his advance to the Ailette would render the whole position on the Chemin des Dames untenable to the Germans, and he had proved the advantages which the enveloping line continued to offer to the attack on this sector of the front. Ludendorff tells us in his *War Recollections* that the same thought had occurred to him and he had thought of withdrawal, but Gen. von Bocken, commanding the VII. Army, was certain that he would be able to repulse any attack; when, towards the middle of April, indications of attack were evident, he asked for two reinforcing divisions and additional artillery; after having received this help he believed himself to be absolutely certain of

success. His effectives had now been brought up to eight divisions on this sector of the front, where the deep caves and concreted shelters and the undulation of the ground offered enormous strength to the defence. General Maistre, on the 12 km. of the attack front, between Moisy farm and La Raque, had in position three army corps in the formation of a square, two divisions in the first line and two in the second: from left to right, the XIV. Corps under Marjoulat; the XXI. under Degoutte and the XI. under Maud'huy; elements of the XXXIX. Corps under Deligny had to support the attack on the right. One thousand eight hundred guns were at his disposal: 900 of 75 mm., 850 heavy guns and 50 long-range or large-calibre guns, besides 460 trench guns. Never before had such a mass of artillery thundered on such a narrow front. The long-range guns were placed on the flanks where they could take a large portion of the German line in rear; the field artillery had been pushed up close to the parallel lines of assault in order to be able to support the attack as long as possible. The artillery preparation lasted for six days and completely disorganized the German position. The heavy shells reduced to shambles a number of prepared underground caves. On Oct. 23 at 5:15 A.M., in darkness and in foggy and cold weather, the attack began.

The XIV. Corps under Marjoulat, attacking from W. to E. towards Allemant, seized at one bound the two lines of trenches which constituted the first position, and then captured the village of Allemant, after having surrounded it; the tanks assisted them to reach the second position and a turning movement brought the corps in position facing north. On its right, the XXI. Corps under Degoutte, by an unimpeded advance, captured the two German positions together with the village of Vaudesson and even that of Chavignon, where it found itself in position in line.

The XI. Corps under Maud'huy supported its right; the 38th Div. under Guyot de Salins (which had captured Fort Douaumont on Oct. 24 1916) had the honour of seizing Fort Malmaison and from thence advanced up to Voyeu-Chavignon. The 66th Chasseur Div. was less fortunate, and overlooked Pargny-Fillain, which still remained in the hands of the enemy.

During Oct. 24 and 25 the advance continued and reached the Ailette as far as Chavignon. But it was only on Oct. 26 that victory was complete on the right, thanks to the intervention of the XXXIX. Corps under Deligny.

The Chemin des Dames was taken in flank and in rear; a relief division, caught by the French artillery, had not been able to come up, and supply had become impossible. During the night Nov. 1-2 the Germans were compelled to evacuate it. "Our losses had been very severe," said Ludendorff, "some divisions had been cut to pieces." For himself, he was indifferent whether he was on the N. or the S. bank of the Ailette; but "after our fights during the whole summer for the Chemin des Dames I suffered a pang in giving the order to abandon it, but we would have suffered losses incessantly if we had wished to stay on there."

This great victory, obtained with relatively small losses, was emphasized by the capture of 11,757 prisoners, 200 heavy guns, 222 trench mortars, and 720 machine-guns. For its careful preparation, clever handling and happy consequence, it will remain as a model of an offensive with limited objectives.

(C. M. E. M.)

#### V. BATTLE OF SOISSONS-REIMS, MAY-JUNE 1918

From the outset the aim of the main German offensive in 1918 had been to break the spirit of the opponents of Germany by numerous blows in the quickest possible succession and to dispose them towards peace. If, therefore, the German Supreme Command wished to retain the initiative, the first great blow must be followed, as rapidly as the transport of the powerful weapons of attack permitted, by a second blow. In itself the most favourable course would have been to continue the attack against the English front at Ypres and Baileul. But here such strong English and French reserves had been posted ready in the meantime that the attack would have to reckon with strong Allied resistance. Similar conditions obtained on the

neighbouring German attacking front farther to the south. Before the front of the VII. and I. Armies, on the other hand; the Allies, relying on the difficulties presented to the attack by the strong positions on the heights of the Chemin des Dames, accessible only with difficulty, had weakened their forces, having sent to Flanders a large proportion of the fit and rested French divisions stationed here in exchange for French and English divisions worn out with fighting there and in need of rest. The disposition of the Allied forces suggested that they expected a continuation of the German offensive on the front between the North Sea and the Oise, since by far the greater part of their reserves were held in readiness there, to the considerable weakening of other fronts, notably before the German VII. and I. Armies, facing whose inner wings were stationed three war-worn English divisions. So the choice of the front of attack and the battle-ground fell on the oft-contested chain of heights between the Ailette and the Aisne, the Chemin des Dames.

*The Battlefield.*—The tract of land between Reims and the great wooded districts of Compiègne and Villers-Cotterêts is divided by the different tributaries of the Seine and the Oise, running from E. to W. into several parallel strips. The most northerly of these strips is a pronounced ridge with steep declivities northwards to the Ailette and southward to the Aisne; along its summit runs the Chemin des Dames leading from Craonne to the Laon-Soissons road. These heights afford an uninterrupted view far over the country lying to the north. In its superior height lies the tactical significance of the Chemin des Dames, for the sake of which so many heavy engagements had already been fought. Since the Chemin des Dames had been in French occupation, Laon with its important railway centre lay under their fire. South of the Aisne lies a second ridge, bounded on the S. by the Vesle. On the left bank of the Vesle rises the third strip consisting of the wide hill country which descends on the S. to the spacious valley of the Marne.

*The Allied Position.*—The French position ran along the Chemin des Dames, and farther eastward into the valley. In front of the position was the Ailette, in whose valley the listening posts of both sides were close to one another. The French positions were not only of great natural strength by reason of their favourable situation, but were also just here particularly strongly fortified by every technical device. The French also had at their disposal a numerous artillery of all calibres. The German attack on these positions was therefore to be regarded as a bold attempt, whose only prospect of success was in effecting a surprise on the French and English and in keeping secret from them the preparations for attack, especially the advance of the artillery.

*Dispositions for the German Attack.*—The German Supreme Command had decided, on the basis of a plan of attack proposed by the army group under the Crown Prince as early as the end of April, to attack with the VII. and I. Armies from the district south-westward of Laon—southwards of Berry-au-Bac in the direction Soissons-Fismes-Reims. If this attack proceeded favourably it was to be prolonged on the right over the Ailette to the Oise and on the left as far as Reims. Simultaneously an attack by the XVIII. Army was to be prepared westwards of the Oise with its centre of gravity in the direction of Compiègne. The German Supreme Command hoped that the push southward would succeed in reaching the neighbourhood of Soissons and Fismes, and by this means attract strong forces from Flanders, so that it might be possible to continue the attack there according to plan. The army group under the Crown Prince Rupprecht was to remain purely on the defensive. On this front, as on other sections of the western front where attack was not intended, feigned preparations for attack were to be made.

Preparations began about the middle of May. The VII. Army under Gen. von Böhm was charged with the main German attack across the Chemin des Dames, the I. Army under Gen. Fritz von Below with the neighbouring attack on the left, and the XVIII. Army under Gen. von Hutier with the at-

tick in the direction of Compiègne. The right wing of the main attack, LIV. Corps and VIII. Reserve Corps, had the task of pushing forward in a south-westerly direction on both sides of Soissons, after taking possession of the plateaux W. of Neuville-sur-Margival and the heights of Jouy and Oestel. The XXV. Reserve Corps was to make its way on both sides of Certy-en-Laonnais direct towards Braisne, and on the E. to take as much country as possible towards the S.; the IV. Reserve Corps was to attack the "Winterburg" (i.e. the height at the extreme western end of the Chemin des Dames, immediately N. of Craonne) with the main force and advance farther in the general direction of Fismes; in concert with this on the left the LXV. Corps, especially charged with the attack on the hills N. of Pontavert, was to occupy with its left wing the river bend N. of Berry-au-Bac.

Of the I. Army at first only the XV. Army Corps, advancing simultaneously with the VII. Army, was to throw the opposing forces over the Aisne-Marne canal. The corps was to provide itself with bridgeheads in order to take the heights of Cormicy if the attack of the VII. Army proceeded favourably.

A further attack to the right of the main attack was prepared by the VII. Corps of the VII. Army, which with its centre of gravity on both sides of Guny was to push forward over the Ailette, making its way in a south-westerly direction towards the Oise. This enterprise was not, however, possible until a few days after the beginning of the main attack, since its execution demanded that a section of the artillery used in the centre of the VII. Army should be moved to that position. The total number of divisions taking part in the attack was 21. The whole attack between the Oise and Reims was indeed planned on a wide front, but its aims were localized.

*Measures for Securing Secrecy.*—The whole success of the undertaking depended on the element of surprise. It was all the more necessary to pay the most careful attention to the measures for the disguising and concealment of the attack as good flying weather and dominating observation posts favoured the enemy's intelligence service. It was necessary to overrun the Chemin des Dames at the first onset, before the local reserves could come into action. The fundamental principle laid down was that the preparation for attack should involve no change of any kind in the landscape. The reconstruction of battery positions, roads; camps or shelters must be reduced to the minimum, or be so camouflaged as not to be visible on the airmen's photographs. The German fighting aircraft continually watched the ground of the front of attack, rail and road traffic, telephone, wireless and postal services receiving the closest attention. All assemblage of troops behind the new front of attack had to be effected with the utmost caution and generally only at night. Every troop, every column, entering the region under the command of the attacking armies received a sheet of instructions in which all the measures necessary for secrecy were again expressly pointed out. There was to be no visible sign of the increase of the number of men bivouacked in any particular place. All transport was to be concealed under trees and irregularly placed. On the appearance of enemy airmen the roads must be empty of troops. No smoke from new positions was to be permitted by day, and at night bright firelight was to be avoided. Guides familiar with the locality were allotted to reconnoitring staffs, so that they might not make mistakes through ignorance of the country. In day-time road traffic was not to exceed its ordinary quantity. All movements for the advance, especially of battery reinforcements and munitions, were to take place only under cover of darkness. The greatest stress was laid on deadening the noise of transport in moving up batteries and munitions to forward positions. All orders and marked maps were kept under lock and key in quarters the farthest to the rear, and might not be taken either on reconnaissances in the foremost lines or into forward positions. Published orders repeatedly warned the troops of the probability of a hostile offensive, in order to maintain the belief that all the preparations made were merely defensive. All the dispositions for secrecy were regularly tested by special officer patrols.

*Artillery Preparations.*—The great difficulties of an infantry attack against the immensely strong positions on the heights of the Chemin des Dames were clearly realized. The ascent of the steep slopes was only possible if the German artillery had succeeded in silencing the greater part of the opposing artillery. Therefore, the greatest attention must be given to the artillery preparation. Col. Bruchmüller, whose capacity had been already proved in the earlier offensive, was entrusted with this.

The ground over which the artillery was to advance consisted, of the depressions N. of the heights N. of the Ailette and the valleys running up to the enemy position and partly overlooked by him. The preparations for the artillery advance were carried out by the divisions in line, the corps staffs entrusted with the attack moving up early enough to be able to direct these preparations. The orders given for the artillery advances were so complete in every detail that a perfect coordination of the whole body of artillery was thoroughly ensured. The infantry had to be firmly convinced that their business in the attack would be substantially eased by the annihilating effect of their own artillery. The numbers of the artillery provided by the Supreme Army Command proved on the whole sufficient.

The employment of the artillery was based on a calculation of the number of batteries, and the kind and calibre of gun required. The reinforcing batteries and columns were brought up this time for the most part by rail, contrary to the practice in the March offensive. Transport arrived from the whole front; the batteries were in most instances placed, to begin with, behind the ground on which the advance was to take place and beyond the zone of the enemy fire. Extraordinary caution was ordered during the advance of batteries pushed up far to the front. The unnoticed advance of the foremost batteries was most effectually assisted by the deafening noise of the frogs of the Ailette valley as it effectually drowned the noise of transport. In the placing of artillery care had especially to be taken that the shelter of the barrage was assured to the infantry, not only over the summit of the ridge of the Chemin des Dames but over its southern spurs during the descent to the Aisne. For this purpose an exceptionally bold disposition of the batteries was necessary. The mass of the artillery had to be pushed unusually far forward. Hundreds of batteries were brought into position, thickly massed in some parts, almost directly behind the foremost line of infantry. The unexpectedly great success was undoubtedly partly due to this exceedingly bold disposition of artillery. Single pieces of the heaviest guns with flat trajectory were also pushed far forward, almost into the line of the other batteries, so as to be able to bring under fire the detrainning railway stations lying far behind the enemy line and the quarters of the higher staffs.

In contrast to the procedure in the former attack all registration was to be abandoned, in order to surprise the enemy as completely as possible. Effective bombardment was to begin immediately; and the first object was to be a thorough gassing of the hostile positions right down into the Aisne valley. The bombardment was divided into three phases. The first consisted in a general surprise artillery attack against infantry positions, batteries, mine-throwers, command posts, central telephone stations, camps, and headquarters, with all batteries and as far as practicable with gas munitions. The second phase was directed to an intensified action against artillery, for which purpose the field batteries attached to the infantry were also drawn in, in order to put the opposing batteries out of action at as early a stage as possible. The third phase was directed especially against infantry and artillery positions and targets in the distant rear of the front.

The beginning of the attack, in contrast to former procedure, was timed before day-break in the earliest morning twilight. This was done with the less hesitation, as the preliminary registration had been abandoned and there was no need to wait for daylight. The beginning of the attack before dawn, moreover, offered substantial advantages for the success of the infantry attack and its exploitation, for which the whole light day was thus made available.



During the infantry attack the principal task of the artillery was to protect the storming infantry while keeping down the opposing artillery fire, to protect the assaulting infantry by barrage advancing in front of them, as well as by the fire of the guns accompanying them. After the infantry attack, owing to the experience gained in former offensives, only so many batteries were to be brought forward as could certainly be sufficiently supplied with enough munitions. Provision was also made to meet the great difficulties which the steep ascent on the S. bank of the Aisne presented to the artillery, by preparing men and material for the building of roads.

All these measures demanded the most meticulous care for every detail, and it was vital that nothing should be forgotten. The placing in position of the attacking divisions and the artillery groups, with all the other preparations, was completed by the evening of the 26th. The beginning of the attack was fixed for May 27.

*The Artillery Battle.*—In the night of May 26–27 punctually at 2 A.M. the German artillery bombardment suddenly began, completely surprising the French and English. This went successfully from the start. The whole valley of the Ailette, the steep slopes of the Chemin des Dames, the Chemin des Dames itself, and the country lying far behind down to the Aisne, were in a short time thoroughly gassed, so that, as was later ascertained, a great part of the gunners left their batteries in panic at the beginning of the bombardment, and many pieces were destroyed at the very beginning by direct hit. In the first ten minutes observers announced numerous munition fires in the battery positions and ammunition dumps of the opposing armies. The fire against infantry and artillery positions was also well directed. Thanks to the powerful effect of the superior strength of the German artillery it was already clear, after an hour and a half's bombardment, that the opposing infantry and artillery were sufficiently subdued to enable the German infantry to venture the assault.

*The Infantry Attack.*—Punctually at 4.40 A.M., while it was still quite dark, the German infantry advanced to the attack. Without difficulty or delay they crossed the Ailette valley which was covered with bushes in some places and marshy in others; during the ascent to the Chemin des Dames serious infantry fights only developed at Chavignon, Pargny and Fillain; on the other sections of the front the German infantry pushed forward almost without resistance on to the heights of the Chemin des Dames. Here the remarkable effect of the artillery preparations was already apparent: the steep slopes had been surmounted, and the first lines were taken almost without firing a shot. The rising sun saw the first files of prisoners descending into the Ailette valley. The procedure adopted in previous attacks by the infantry had also stood the test on this occasion. There were no innovations in infantry tactics.

By 7 A.M. the I. Army had already reached the canal, the objective of their attack, and part had crossed it. Since they were to await the left wing of the VII. Army before further advance, a halt had to be made there according to orders. Thus the opposing army gained time to reform their units and to rally, while those in front of the VII. Army were overrun by the advance of the attacking divisions so long as they felt the effect of overwhelming German artillery fire. This was an essential difference between the attack of the I. and VII. Army, and was to be of decisive importance.

By 9 A.M. the German infantry, after breaking through the whole enemy system, had reached the line Vauxaillon-Jouy-Pontavert-Berry-au-Bac; on rapidly built roads, accompanying batteries and mine-throwers had also reached the heights of the Chemin des Dames and followed close on the heels of the infantry. Numerous aeroplanes attached to the infantry and artillery accompanied their advance over and before their fronts, while the battleplanes in repeated flights helped to break recurring resistance.

*The Passage of the Aisne.*—The farther advance from the heights of the Chemin des Dames against the Aisne became a regular race between the divisions of the VIII., XXV., and IV.

Reserve Corps and the LXV. Corps. Without waiting for fresh orders each division, taking advantage of the successful surprise over their opponents, had on its own initiative pressed forward without halting. Soon after 11 A.M. the first German companies crossed over to the southern bank of the Aisne on bridges mostly intact. A vast and unexpected success had been gained. A wide and apparently impassable stretch of country, which had been for years the scene of the heaviest fighting, had been captured within a few hours after a short artillery preparation. Of the divisions of the defenders two English and three French had almost ceased to exist. The survivors streamed into the prisoners' collecting stations, while countless guns stood abandoned in their positions, some of them undamaged.

In the afternoon and evening the attack on the principal fighting front of the VII. Army went forward without a pause farther in the direction of the Vesle valley. Engineering and road-making troops worked with the utmost effort to level a path for the columns following through the enemy positions and over the steep way up to and down from the Chemin des Dames.

On the two wings the advance was considerably slower; on the right, before the front of the LIV. Corps S. of Vauxaillon, and at Laffaux, the Command had not recognized so quickly the favourable nature of the situation, and had not attacked with such unsparring vigour as in the centre; otherwise Soissons would probably have fallen on May 27 and at latest on the 28th, and the French, before they could have organized themselves for resistance, would have been compelled to evacuate all of the ground lying between the Oise and the Aisne. Here, just as before the front of the I. Army on the heights of Cormicy and farther E., the French had time to take up a position and to rally for fresh resistance, so that the infantry engagements became gradually more and more severe. The machine-guns had to be taken one by one, and here and there the enemy artillery again became active. The VIII. Reserve Corps also could only take Vailly after heavy fighting. Here again rich booty in guns fell into German hands, among which were the railway guns, famous for their bombardment of Laon, which had been injured by the German long-distance guns and their withdrawal thus delayed.

The Vesle was reached by the XXV. and IV. Reserve Corps; and in the darkness sections of the XXV. Reserve Corps passed southwards of Courcelles and Paars, while sections of the IV. Reserve Corps occupied the steep slopes at Fismes and Magneux. On this very first day of fighting the Germans had penetrated the enemy positions over a front of about 60 km. to a depth of about 20 km. Over 15,000 prisoners and immeasurable army supplies had been taken. The German losses were proportionately small.

The second day of the battle, May 28, saw the first violent counter-attack of the opposing army against the right flank of the German attacking troops. The attempt was made in this to prevent a further widening of the breach on either side, and the first available reserves were flung against the German wings, divisions being hurried up by rail, motor and boat, in order to arrest and throw off the German thrust. Nevertheless the speed of the German advance was not lessened on this day. On the right wing the LIV. Corps, after repulsing French counter-attacks, captured the heights N. and N.E. of Soissons. On the left the German divisions pressed forward until midday, over the whole sector of the Vesle, from Missy on the Aisne by way of Luhy-Courville on the André as far as the northwestern fort of the fortress of Reims. The objective was thus reached after a day and a half's fighting. But in the ardour of the pursuit the troops stormed on without orders, though in agreement with the intentions of the higher command, in order to improve their success by determined pursuit. The order given by the Supreme Army Command at noon of the 28th to continue the attack as far as the line of heights S.W. of Soissons-Féren-Tardenois—the heights S. of Coulouge, reached the troops when they were already storming forwards. On the right wing of the VII. Army, the VII. Corps had already joined the attack on May 28 without waiting for the completion of the preparations begun at this point. Here, however, the resistance was so

obstinate that it was only in the course of May 29 that the dominating heights at Crecy-au-Mont were captured.

On the following days the VII. Army pushed forward with its centre in a southern direction as far as the Marne. The right wing of the I. Army, which had extended the attack towards Reims on the left, pressed forward between the Marne and the Vesle against the wooded hills of Reims, but soon met here with unconquerable resistance, as strong French reserves had been placed on this front. The right wing of the VII. Army took Soissons, and between the Aisne and the Marne gained ground towards the heights S.W. of Soissons, and up to the eastern edge of the wood in Villers-Cotterêts.

On the 29th the occupation of the important road and rail centre of Soissons as well as of Fère-en-Tardenois was of tactical importance. In both places immense masses of material fell into the hands of the Germans, especially in the wooded country at Fère-en-Tardenois, where they captured a vast dump of French and American munitions, pioneer and transport material, which the French had not succeeded in removing in time in spite of a violent counter-attack. On the left wing on this day Reims, against the N.E. front of which the VII. Reserve Corps of the I. Army had advanced to the attack, was so surrounded with the German troops that all the roads and railways leading from Reims to the Marne lay under German fire.

On May 30 violent counter-thrusts by the French had held up the advance of the German right wing, while the German centre in a rapid advance had by midday reached the heights of the northern bank of the Marne between Château-Thierry and Dormans, on the possession of which the use of the important stretch of rail Paris-Epernay-Châlons depended. On both days the pursuing German troops had passed beyond the objectives fixed by the Supreme Army Command, so that they reached the Marne earlier than it had been thought possible. A further advance of the centre, pushed out southward like a wedge, beyond the Marne seemed to involve great risk so long as the German wings on the E. and W. had not won further ground and so broadened the base of attack.

On May 31 instructions went out from the Supreme Army Command not to penetrate farther S. over the Marne, but to extend the successes against the wooded heights of Reims and up the Marne towards the W. in the direction of Villers-Cotterêts, so as to ensure above all the secure use of the railway line leading E. of Soissons from the Aisne to the Vesle valley, and to be able to give effective tactical support to the later attack by the XVIII. Army over the Montdidier-Noyon line, for which plans had been made.

On May 30 and 31, and particularly in the first days of June, strong counter-attacks were made by the French, with the strong reserves assembled in the district S.W. of Reims and S.W. of Soissons, plainly with the intention of pressing in the flanks of the German advance. All these attacks were nevertheless bloodily repulsed, as were the American attacks a few days later against Château-Thierry, which had fallen into the hands of the Germans on the 31st.

In the first days of June the fighting became steadily more severe, as the Allied resistance, reinforced by an uninterrupted flow of fresh divisions, grew more obstinate and the counter-attacks progressively more violent and extended. The Germans therefore succeeded in gaining only little ground. The powerful impetus of the German attack had come to an end.

According to orders sent on June 7 from the Supreme Army Command, the VII. Army was, indeed, to continue to press forward slowly on both sides of the Aisne, but was otherwise to stand on the defensive; the I. Army was only to carry the attack farther where a gain of ground seemed necessary to reach a tactically more favourable position. The following days saw a series of local engagements extremely costly for the French, in which individual places, heights and tracts of ground changed hands many times without yielding definite success. On June 17 the German armies stood with their right wing and centre roughly on the line Noyon-Fontenoy, the eastern edge of the forest of Villers-Cotterêts, Château-Thierry, and up the Marne

to Vermeuil; the left wing had penetrated to the outlying woods W. of the wooded heights of Reims, and close to the W., N. and E. front of Reims, which was closely encircled. In view of the unexpectedly rapid advance of the centre of the VII. Army the strategical situation was unfavourably affected by the fact that the capture of Reims had not been effected; this made difficult the bringing up of drafts for the sections of the VII. Army pushed forward to the Marne, because of the lack of sufficient railways.

The tactical result of the battle of Soissons-Reims for the Germans was great beyond all expectation. Over 65,000 prisoners fell into their hands. The booty included about 700 guns and 2,500 machine-guns; in addition the French and English losses in *matériel* were enormous. The success was due primarily to the spirited attack of the infantry, the equally brilliant preparation and execution of the artillery attack and the complete surprise of the French and English. By the very clever maintenance of secrecy the French command was so successfully misled that they kept their reserves assembled at the wrong place. Thus it was possible by an attack with narrowly limited aims, carried out by relatively weak forces, to develop an operative success which ended in a substantial weakening of the fighting force of the Allies. Gen. Foch had been compelled to bring up gradually against inferior German forces more than 50 divisions. The German losses on the other hand were small, so that the exhaustion of force on the French and English side was far greater than on the German. (H. v. H.)

#### VI. THE GERMAN OFFENSIVE OF JULY 15 1918

The preceding German offensives of 1918, the Somme, the Lys and the Aisne-Marne, had left the German army with three salients projected from its main line on the western front; salients costly to hold and dangerous because the means were lacking properly to entrench them and the communications were deficient, both in roads and railways. Particularly was this true of the Marne salient. To push the attack on Amiens was obviously the desirable strategic course, but owing to the difficulty of organizing an attack there, and to the massing of Allied reserves behind that part of the front, it offered little chance of success. Ludendorff consequently turned his attention to pushing forward the Lys attack. But the nature of the terrain and the activity of the British artillery and aviation made the accumulation of the necessary *matériel* a difficult, slow and costly undertaking. Early in July it had become apparent that Crown Prince Rupprecht could not be ready before August. Something had to be done in the meantime to preserve the initiative. The attack in the Champagne was Ludendorff's solution of the problem. The Allied front in that sector was known to be weakly held. A successful attack there would not only ease the difficulties of communication in the Marne salient but might lead to the evacuation of Verdun, giving the Germans an additional and much-needed railway line for the supply of their armies in France. An additional result hoped for was the withdrawal of Allied reserves from N. to S., facilitating the German attack in Flanders planned for August.

The date set for the attack was July 12, but delays in the preparations deferred it to the 15th. The plan called for the VII. German Army to force the crossing of the Marne between Jaulgonne and Vermeuil (20 km.), gain the heights S. of the Marne and advance eastward by both banks of the river on Epernay. Fifteen divisions were disposed for the attack on a front of 36 kilometres. The I. and III. German Armies, E. of Reims, were to advance southward on Châlons-sur-Marne, connecting with the VII. Army near Epernay. Their front of attack was 44 km., for which they employed 15 divisions in the front line and 10 in reserve. No attack was to be made about Reims itself since that city was bound to fall if the other attacks succeeded. On the French side the I. and III. German Armies were opposed by the IV. French Army of Gouraud; the VII., in the sector of attack, by the V. Army of Berthelot and the VI. of Degoutte. These French armies consisted in the main of worn or second-class troops but were fairly compactly disposed and were re-en-

forced, that of Berthelot by one British and two Italian divisions, and those of Gouraud and Degoutte (in the sector attacked) each by an American division. As a factor of strength on the French side it should be noted that Gen. Gouraud had exceptional prestige and influence with his men. In the matter of intelligence service the French staff had learned its lesson from the bitter experience seven weeks before in the surprise attack on the Chemin des Dames. In spite of the utmost endeavour of the Germans to maintain secrecy regarding their preparations for attack, every phase of them was sought out, chiefly through air observation, plotted on maps and carefully studied to determine the time, place, extent and method of the next German effort. The information thus gained was supplemented by statements of prisoners so completely that not only were the approximate time and place of attack known to the French more than a week in advance, but on the eve of attack even the time of artillery preparation and of infantry assault were learned.

The French plan to meet the attack was to abandon their front lines, leaving in them only small detached posts backed by occasional wired strong points, and to take up a position far enough in rear to be beyond the ready interference of the German artillery, thus causing the superior German artillery to waste its preparatory fire on virtually abandoned trenches and neutralizing its influence on the infantry combat. The execution of this plan in the sector of the IV. Army was greatly favoured by the existence, several kilometres in rear of their front lines, of a complete system of trenches which had been carefully constructed and occupied during preceding years. It was from these rearward trenches that the French had advanced in 1917 to gain their present lines. Thus not only could the army change its position back to them swiftly and secretly, but the Germans could have no means of learning, by direct observation, that such a shift had been made.

The battle began on the 15th shortly after midnight, according to the German plan, with an intensive artillery and trench-mortar fire on the French trenches believed to be occupied. In the IV. Army sector of Gouraud, thanks to his dispositions, little damage was done to the personnel, though the abandoned trenches were mostly wiped out by the grueling fire. In the other sectors under attack, while the same policy prevailed in theory, there does not appear to have been the same consistency in its execution and some of the Allied troops suffered severe losses. The French counter artillery preparation had begun an hour before midnight, but, owing to the relative weakness of their artillery arm, and the rearward positions taken up by the IV. Army, does not seem to have made its influence felt. The infantry advance began at 4:15 A.M. In the sector E. of Reims the assaulting troops, preceded by a barrage, walked almost unopposed through the abandoned French position except that the French artillery constantly increased the intensity of its fire. After the German protective barrage had been lifted, to enable the infantry to pass beyond its limits, the real battle began—fresh French infantry in a prepared position well supported by guns, against unsupported German infantry in the open. The Germans tried to bring up some accompanying guns, mostly by hand, but without success.

As to position it was a drawn battle, but the heavy losses completely discouraged the Germans. During the night they attempted to reorganize their attacking line and arrange artillery support and thereby to renew the assault on the 16th, but the attempt proved abortive, and by noon Ludendorff had ordered its abandonment and directed the troops of the I. and III. Armies to be redispersed for the defensive.

In the VII. Army sector of attack the Marne was successfully forced, and, except in the sector occupied by the American division, the heights on the S. bank were occupied to a depth of 5 kilometres. The direction of attack was then shifted eastward on Epernay, but being beyond the range of effective artillery support from the N. bank, and not being able to get artillery across the river to any material extent, the attack soon slowed down. North of the Marne the attacking troops soon encountered the deep ravines and rocky, forested heights of the mountain

of Reims. Progress was made in the Marne and Ardre valleys; but on the wooded heights, where effective artillery support of advancing troops was impossible, the attack was easily checked. On both banks of the Marne the attack was renewed on the 16th in the direction of Epernay, with resulting slight gains of ground, and again on the 17th without result except increasingly heavy losses for the attackers. On the afternoon of the 17th, on orders from German G.H.Q., the VII. Army also passed to the defensive and the battle came to an end.

As an incident of the battle S. of the Marne might be mentioned the defence of the sector S. of Jaulgonne, which has been termed the most brilliant single feat of American arms in the war. The 30th U.S. Infantry, under Col. Butts, had prepared for the attack by building numerous trenches for the German airmen to photograph and for the artillery to register on, and more numerous rifle pits and machine-gun nests carefully camouflaged or concealed. By day the trenches were occupied, by night the rifle pits. The German artillery preparation had wiped out every trench, but the infantry in its pits and nests, despite heavy losses, accounted for more than its numbers in German dead and turned back the attack of a division.

The result of this battle was the beginning of a great moral reversal which was to find its completion in the ensuing counter-attack at Soissons. Until the attack of July 15 the Germans had been confident of success. The attack showed them that they could no longer command it. The Allied troops, on the contrary, were buoyed up by the fact that not only had a way been found to stop the German attacks, but they had been stopped with far lighter losses to the defenders than to the attackers. From a tactical point of view it may be said that the German attack had all the strength and all the weakness of the German war machine. The general staff had invented a stereotyped normal attack which was here applied on the western front for the fourth time, virtually without change of method. The same artillery travelled from front to front, to conduct the artillery battle. Infantry units received identical training. The system produced a powerful onslaught, but killed independent initiative and discarded participation in the planning by subordinate commanders. Its failure in the Champagne may be ascribed to its inherent inapplicability to the situation and to the terrain. German G.H.Q., preoccupied by German internal questions—Russian, Austro-Hungarian and many other problems,—had not the time nor the patience to study out the special requirements of the Champagne problem, nor did it permit subordinates to make the plans. The same rigid point of view speeded the military downfall of Napoleon.

On the Allied side great credit must be given to Gen. Pétain and Gen. Mangin for their skillful measures to foil the German plan after it had become known. The Germans were superior in numbers and, at the start, probably had higher moral. The victory was on the side of superior leadership, both higher and lower. (A. L. C.)

#### VII. THE ALLIED OFFENSIVE OF JULY 18 1918

On July 18 1918 the Allies regained the initiative, and the offensive passed to their hands, thereby assuring them of victory. It is generally thought that the aim of the attack carried out on that day by the French X. Army was to clear the front of the IV., V. and VI. Armies, which had been attacked since July 15, and that this had indeed been its first result. Herein lies a double error. At first, the success gained on July 15 by the IV. Army under Gouraud had, by checking the I. and XIII. German Armies, nullified the success of their VII. over the V. Army under Berthelot and Degoutte's VI. Army, a success which, being limited, was dearly bought. Ludendorff informs us that after July 17 he issued orders to those elements which had established themselves on the left bank to recross the Marne; this difficult withdrawal was due to take place on July 20. He gave up the idea of renewing the attack on Reims, which would necessitate the immobilization of powerful forces for a subsidiary venture. Accordingly, he diverted all his strength towards Flanders, where a new offensive on a large scale was

developing. He went personally to Avesnes, where headquarters were, in order to supervise the preparations. The French attack of July 28 had not then as its result the stopping of the German attack. This was, moreover, not the aim of this Allied offensive. There was no question of a counter-attack, but of an operation thought out and prepared for its own ends, independent of the German offensive.

Gen. Mangin had taken over command of the X. Army on July 16 in place of Gen. Maistre. The latter had twice stopped the German advance between the Aisne and the Ourcq, and had, in a small operation on June 15, recovered nearly the whole of the ground lost on the 12th and 13th. It immediately appeared evident to Gen. Mangin that he now found himself in command of the X. Army under conditions similar to those that he had just left on the Méry-Corcelles plateau. Now, in his operation orders of June 10, ordering the counter-attack for the following day at "1100 hours" (11 A.M.), Gen. Mangin concluded with this sentence, which he wished to be communicated to the troops: "To-morrow's attack should mark the end of the defensive battle which we have been waging during the last two months; it should mark the checking of the Germans, the resumption of the offensive, and lead us to success."

After having saved Compiègne and stopped the German advance, the counter-attack of Méry-Corcelles had been stopped by the French High Command, owing to lack of available forces, but when Mangin found himself on the W. flank of a pocket of much larger extent, he immediately studied with his new staff the question of its reduction, to follow up with an offensive and finally to grasp from the enemy the initiative of the operations. On June 18 he received instructions to examine under what conditions the communications to the S. of Soissons could be disturbed: firstly by aerial bombardment, secondly by a rapid advance from this front, which would enable him to place his heavy batteries in a position which would command the bridges of Soissons and the main exits of the town. On the 20th he sent his estimate of his requirements in infantry and artillery to carry through this operation, from which he foresaw a rapid extension southwards; and he asked the Command to consider how the success could be turned to advantage.

In order to start under good conditions, he suggested a series of minor operations which were intended to improve the positions from which he would attack. Without further delay he started carrying out his scheme, and vigorously pushed forward his preparations on the front of attack. Numerous battery emplacements and ammunition dumps were established.

All the ambulances and clearing stations, which had been placed so far back with excessive caution, were brought forward to within a reasonable distance, which would enable the wounded to be dressed without inflicting on them the miseries of transport. Minor operations followed rapidly one after the other on the front of this army, and enabled him to ascertain the degree of exhaustion of the German troops, whose heavy losses had only partially been made good. On June 28 a slightly more important advance considerably improved the situation, and 1,000 prisoners were taken. On the 29th Gen. Mangin received Gen. Pétain's letter approving of the plan of action, which had already started to be put into execution, and which was agreed to also by the High Command, whose approbation had been obtained through liaison staff officers.

The X. Army's front likewise was improved to the N. of the Aisne by a minor operation, in which, on July 3, 1,100 prisoners were taken. It was indeed important not to draw the attention of the enemy to the position of probable attack, and it was clear besides that, having attacked eastwards, the X. Army would be called upon to attack in a northerly direction. Gen. Mangin was able to write on July 3: "The minor operations undertaken by the X. Army during the second fortnight of June have been carried out very easily. Without attaching to them more importance than they deserve, the proof can be seen that the enemy experienced the same difficulties as we do in defending himself against troops making use of methods of actual attack. There is ample reason for thinking that an attack carried out

on the plateau to the S.W. of Soissons, under conditions which were outlined in the scheme of June 16, would present not only the best chance of success, but could also bring about such a development that would result in the immediate exploitation of the factor of surprise and would lead to the elimination of the Château-Thierry pocket." The factor of surprise was now quite possible. On the one side the forests made it possible to conceal until the last moment the manoeuvres by which the infantry were placed in position; on the other side the incessant movements of artillery which had taken place during the last three weeks on the X. Army's front would probably prevent the enemy from noticing the installation of new batteries in the Villers-Cotterêts region. General Mangin asked for the selection and putting in position of all forces necessary to enable him to carry out the intended offensive.

On July 8 a further operation improved the position of the X. Army to the S. of the forest of Villers-Cotterêts. On July 9 Gen. Mangin received a letter from the commander-in-chief approving of his plans. It made no further mention of the elimination of the Château-Thierry pocket, but it said:—"Undoubtedly this operation not only presents the best chance of success, but it can be profitably exploited. Further it constitutes a most efficacious demonstration against the German offensive." From now onwards it was necessary to prepare for the operation in the greatest detail, in such a way that the concentration of forces and the launching of the attack could succeed one another within a very short time—four days as a maximum. The concentration must be ready to start on July 15.

From July 9-13, the situation continued to improve to the S. of the Villers-Cotterêts forest. The Savière valley, which presented a serious obstacle in that area, was taken. On the 13th, Gen. Mangin, in pointing out these results, declared that these minor operations, which had been carried out at very small cost, had been sufficient to exhaust the five German divisions opposing him. They were replaced by other divisions, which only a short time before had been withdrawn from the front and had not had time to rest or reorganize; their strength having been reduced to 40-50 men per company instead of 150. The enemy was considerably weaker after these reverses; the instructions which were issued to sector commanders, and which were captured, were quite clear:—"Hold on at all costs, without hoping to be reinforced; the bulk of the German army is being kept in reserve for the great offensive." Accordingly, the situation was favourable for an attack.

The X. Army now consisted of 16 divisions, 10 of which were in the first line, with 780 guns, 530 heavy guns, 132 long-range guns. Except for the latter the means at disposal were inferior to those available for previous offensives, but the force had only hastily gathered formations opposing it, and the factor of surprise was being counted on. Finally, telegrams dispatched July 13 fixed the launching of the attack for July 18, and the beginning of the concentration for July 14.

On July 15, at "0900 hours" (9 A.M.), important moves of concentration which had been commenced two days previously and were to be carried through on the following days were interrupted by order of the French C.-in-C., owing to the German offensive which had just started on the front of Gouraud's IV. Army. Gen. Foch, however, as he was visiting the headquarters of the army groups, heard of this counter-order and annulled it. The preparations, which had been suspended for some hours, were resumed—but so quietly that the enemy, who had thought up to the 11th that an attack was probable, had meanwhile been completely reassured. "The troops had ceased thinking that an attack would come," said Ludendorff; "one of my friends, a divisional commander, told me that from the 17th he had been in all the first lines and had gained the impression that profound quiet reigned in the lines of the enemy."

*The Offensive.*—On July 18 at "0435 hours" (4:35 A.M.), the X. Army hurled itself against the enemy between the Aisne and the Ourcq on a front of 25 km. without any sort of artillery preparation. Three hundred and twenty-one tanks accompanied the infantry over all places where it was possible to go; they

were preceded by a dense barrage, whilst counter-battery work was vigorously carried out. The Germans were completely surprised. The first lines were thrown into confusion in the twinkling of an eye, exposing the batteries, which were captured. An advance of 8 km. was made with particularly brilliant results in the centre, where the 1st and 2nd American Divs. coöperated with Dangan's Moroccan Div., some of the best storm troops.

On the river N. of the Aisne a little artillery preparation lasting three-quarters of an hour had been found necessary against a strong opposition. The 162nd Div. under Messiny had on their side attained the objectives which secured the flank of the main attack.

To the S., after a short artillery preparation, the VI. Army under Degoutte had likewise gone forward in a brilliant manner. On the left the rapidity of its advance had assisted the right wing of the X. Army, whose progress had been held up in the dense woods. It attacked without reinforcements, with its divisions in line, and was reinforced gradually by the American divisions which infused a new spirit into the troops and called forth a lively emulation. On the first day, 10,000 prisoners and 200 guns were captured by the X. Army, and 2,000 prisoners and 50 guns by the VI. Army.

Meanwhile Gen. Pétain went with Gen. Fayolle to the post of observation where Gen. Mangin was following the development of the battle. General Pétain considered that the results obtained exceeded his best hopes, but that their exploitation was necessarily limited by the means at his disposal and by the general situation; he took into consideration that the enemy was on the S. bank of the Marne. No more reinforcements could be sent to the X. Army, and from now onwards it had to organize itself in depth in such a way as to be able to maintain itself, relying on its own resources, on the ground conquered. But Gen. Foch, warned by Gen. Mangin, gave orders for the advance to be continued. On the following day the X. Army was informed that four new divisions had arrived, two of which were British divisions taken from the reserves at the disposal of the Allied C.-in-C. Gen. Fayolle expressed the same view as Pétain's to the commander of the VI. Army, but the attack likewise continued on that part of the front.

The struggle continued. The VII. German Army had brought into action its three divisions in reserve, which were promptly reinforced by two more. The Germans recovered, and the struggle became intense. Having been compelled to give up his offensive in Flanders, Ludendorff sent to the Aisne all those divisions given to the Crown Prince of Bavaria. The X. French Army fought over open country against troops at least equal in number to their own and sometimes superior. The American divisions had been withdrawn; some gun crews had asked and obtained permission to prolong their stay with the French troops; they made use of the heavy guns captured from the enemy and they appeared to think it their duty at least to send back the supply of gas shells, which was considerable.

The British divisions came into the battle at the most difficult moment. The 15th Scotch Div., under Gen. Reed, covered itself with glory in the attack on the *château* and park of Burzancy on July 28. The 34th British Div., partly composed of units which had come back from Palestine and were new to the fighting in France, surpassed all expectations when they took part in the attack on Grand Buzoy on July 29. On Aug. 1 this ridge, which overlooked all the country between the Ourcq and the Vesle, was carried by the X. Army.

The importance of this success was lost sight of at headquarters, and on the night of Aug. 1-2 the commander of the group of armies, who was anxious to husband his troops, wrote:—"The X. Army will continue to act on the right in the direction of d'Arcy-Ste. Restitue; on the rest of its front it will maintain a defensive attitude. The forces which are in front of it are obviously of equal strength, and the only chance of making any headway is by dealing a succession of local blows, prepared in detail and always planned according to the capacities of the reduced force at its disposal. These forces will be further reduced when the expected withdrawal of the British divisions

takes place." But the continued pressure on the enemy led to quite another result, and the general commanding the army sent the following telegram which was to be immediately communicated to the troops on the whole front:—"Forward! The victory of August 1st consummated that of July 18th and has ended in pursuit. The roads are terrible, but if it is raining for us it is also raining for the Boche. Press hard on their heels, hustle them and break through the feeble centres of resistance when they will try to hold up your victorious advance. This evening the X. Army must be on the Vesle."

At "1900 hours" (7 P.M.) the *chasseurs* of Villemot's division entered Soissons. The Aisne, as far as its confluence with the Vesle, and the whole course of the latter river, had been reached by the X. Army on Aug. 3, and by the VI. Army on the 4th. The I. American Corps under Gen. Liggett, which had gradually been brought into action during the battle, had taken an increasingly important part in the operations of the VI. Army, which included as many as six American divisions. The V. Army under Berthelot had attacked under most difficult conditions, as it had reestablished its front after some days' hard fighting, during which it had been compelled to give way a little; but always holding on to the Reims mountain. Although the V. Army had very difficult ground to cover, it arrived at its objective on the Vesle.

*The Results.*—Gen. Mangin was able to say thus to his troops:—"You have captured 20,000 prisoners, including 527 officers, 518 guns, 300 *minenwerfer*, 3,300 machine-guns, parks and ammunition dumps and everything that a large army compelled to retreat precipitately had to leave behind it. You have even taken back from the enemy the depots where he had gathered together the results of his thefts. You have saved from pollution by these civilized barbarians, Soissons, Valois, the whole of the isle of France, the cradle of our nation, with its harvests untouched, and its ancient forests. You have removed from Paris a most presumptuous menace and have given to France the consciousness of victory. You are most worthy of your country."

From the German point of view, this victory as a first result prevented the proposed offensive in Flanders, the preparations for which had already been started on the 16th. Reserves intended for this offensive had been used up between the Marne and the Vesle, where they had been exhausted to such an extent that their normal reorganization had become impossible.

"As in every battle," said Ludendorff, "the losses have been considerable in the engagements fought since July 18th. The 18th July in particular and the defensive engagements which followed cost us very dearly, although we had been able to recover our wounded, and the number of our men who had been taken prisoner was not great." (He ignored, however, the number of 30,000 for the X., VI. and V. French Armies.) "The losses in the struggle were so important that we decided to break up about 10 divisions, 3 to assign their infantry as reinforcements to the other divisions."

Ludendorff, who with commendable care kept a record of each operation and generally drew therefrom very wise conclusions, had only been moderately well informed on the last battle. He thought that it had been preceded by a short and heavy artillery preparation and by clouds of gas, all of which was pure imagination; he also pretended to discover a new invention. "Tanks were seen to be used for the transport of troops. They crossed our lines, and after unloading the occupants, who formed nests of machine-guns in our rear, returned to find further reinforcements." The passenger tank, however, still remained to be found.

The presence of the 1st and 2nd American Divs., which attacked so brilliantly near Vierzay and Domniers, themselves capturing 7,200 prisoners and 21 guns, appeared to have escaped Ludendorff altogether. He had the temerity to write:—"The six American divisions which took part in the battle suffered heavily without obtaining any results."

Further, the reasons which he gave for giving up the offensive in Flanders were surprisingly indifferent. "The enemy had

every opportunity of being prepared for the offensive. If he gives us the slip as he did to the east of Reims we would be unable to obtain a decision. Should he resist, his numerous reserves were in a position to stop us as on the 10th and 11th of June in the direction of Compiègne." Ludendorff appeared to admit that the mere fact of establishing a protective zone in front of a defensive position made it impregnable. His *maréchal* was affected as seriously as that of his troops. (C. M. E. M.)

#### VIII. THE ALLIED OFFENSIVE OF AUG. 17-20 1918

Even before the French X. Army had reached the Vesle and the Aisne, the continuation of the offensive on the N. bank of the Aisne had been considered. The preparations for this scheme were taken in hand during the advance of the IV. British Army under Rawlinson and Debeney's I. French Army, which began on Aug. 8. Marshal Foch thought that the progress of this offensive would cause the Germans in front of the III. Army under Humbert to retreat, and then those opposing Mangin's X. Army. Foch then considered that the two armies could attack in succession in order to cover the right flank of the Franco-British advance, thus widening the front of this battle. In the operation plan of the X. Army it was expected that the attack would bring them into position along the Oise and the Aisne, and then, all efforts being concentrated on the right, the attack, facing E., would ensure egress from Soissons and would thus be developed in such a way as to outflank the position of the *Chemin des Dames*.

The British attack, however, met with steady resistance; the ground cost them more and more dearly, and was no longer proportionate to the losses in men. In explaining this state of affairs to Marshal Foch, Sir Douglas Haig pointed out that he would provisionally suspend his attack, which had been so brilliantly started on Aug. 8 to the S. of the Somme, but he would renew the offensive farther to the N. by two successive operations, the first of which would start on Aug. 20 against Arras. Marshal Foch informed Gen. Fayolle, commanding the group formed by the I., III., and X. French Armies, of the decision, and asked him when his armies would be ready to renew their attack. On Aug. 16 Gen. Fayolle, in discussing this matter with Gen. Mangin, informed him that the I. and III. Armies were not in a fit state to attack, and that consequently the X. Army, whose effectives were not sufficiently strong to attack unaided, should content themselves with small local demonstrations. This was not the opinion of Gen. Mangin, who was convinced above all of the necessity of continuing the offensive. He said that the X. Army was ready to attack on the 18th with 11 divisions in the first line and 3 in the second line (3rd, 11th and 14th Inf. Divs.), but that he proposed to postpone the operation to the 20th, as the new British attacks were due to start on that day. He carried his point, though he had not sufficient artillery at his disposal for this attack: 1,138 guns, including 324 75-mm. guns, 540 heavy guns, and 274 long-range guns. This artillery strength, it is true, appeared weak in view of the extent of the front which had to be attacked, but the moment had arrived to set aside calculations based upon past experience and to consider the shaken condition of the enemy whose power of resistance had very much diminished.

*The Offensive.*—Before the front of the X. Army the enemy had his chief line of resistance at a distance of between 2 and 3 km. from the front trenches. This scheme of defence, which was in accord with the ideas adopted by both sides, had enabled Gen. Gouraud's army to carry out its magnificent resistance on July 15th, and the numerous prisoners taken had disclosed all the details of the scheme.

On Aug. 17 and 18, the divisions in line had seized all the covering zone, and had even gained a footing in a certain part of the line of resistance, taking over 2,000 prisoners.

From the evening of the 18th to the morning of the 20th, for 36 hours, all the artillery was pushed forward in order to be able to support the advance of the infantry as long as possible without changing position. In the orders for attack it was laid down that, after the capture of the two enemy positions, the

infantry should be reformed at the foot of the slopes and should then push on as far as the banks of the Oise and Ailette. Gen. Fayolle had not wished that positions should be established in the valleys, where, as he remarked, trenches in marshy ground would be difficult to occupy during the winter; but the hour for such anxieties had evidently gone.

From the 17th, artillery preparations against the second German position had continued without stop. On the 20th, at "0710 hours" (7:10 A.M.), the X. Army attacked, and all the German positions were captured. On the 21st, the French came into position against the support divisions which had been brought up to attempt to reestablish the situation, and on the 22nd they reached the Oise and the Ailette.

Gen. Mangin said:—"The time has come to shake off the mud of the trenches." It was so. Ludendorff tells us with regard to these events that, in spite of all preparations, the battle had taken an unfavourable turn; the nerves of the German army were strained; the troops did not everywhere stand against the heavy artillery fire and the assaults of the tanks. "We received in this a fresh warning. We had suffered our more heavy and irreparable losses. The 20th August was also a day of mourning. In truth, it encouraged the enemy to continue his offensive. I calculate that the enemy offensive will continue between the Oise and the Aisne in the direction of Laon. The direction of the attack was well chosen, as the position of the XVIII. Army to the N. of the Oise and that of the VII. Army to the N. of the Vesle should be made untenable thereby. The enemy maintained a strong pressure against the Soissons-Chauny line. Very severe engagements were fought here, marked by cruel alternatives if unsuccessful. One could not yet say what would be the issue." It is interesting to compare these remarks of Ludendorff with the considerations that influenced Gen. Mangin in bringing about his attack. These were:—(1) that the employment of great forces between the Oise and the Aisne was justified for the reason that this region would always be the pivot of the manœuvre; (2) that the enemy sought to reestablish his position in making use of each of these lines in succession—(a) the Aisne, (b) the Hindenburg line (*Chemin des Dames*), (c) the Ailette, (d) the Serre; and (3) that the hinge of enemy movement would always be approximately on the axis Soissons-Laon. Thus it was vital to apply the maximum force possible in this region in order to smash the hinge, and to compel successive withdrawals on each wing which would assume growing importance.

The advance of the X. Army facilitated that of the III. Army towards the *Lassigny massif*, and both armies joined up on the Oise. The X. Army continued to press eastwards between the Ailette and the Aisne. In spite of a strong resistance the advance was carried on by successive assaults. On the 30th, the 32nd American Div. under Gen. Ham captured Juvigny in brilliant fashion. During Sept. 4 and 5 the Germans gave up the Ailette and the Vesle, and retreated to the borders of the Coucy forest. Between the two it only remained to capture the Laffaux position which linked them up. The X. Army only possessed weak effectives in infantry, artillery, and even in munitions; nevertheless, on Sept. 14 the I. Corps under Lacapelle and the XXX. Corps under Penet broke into the Hindenburg line on the Laffaux plateau, taking 2,400 prisoners.

The attack developed during the succeeding days, and the advance continued towards the *Chemin des Dames*, in spite of German counter-attacks; it was only stopped on the 20th upon the order to "organize on the ground taken in such a way as to hold on to the advantages won and to take every step to cut down losses and prevent fatigue with a view to be in a position to pursue the enemy should he retreat."

But the general attack had begun. In the centre of the vast line, the X. Army hastled the enemy, who was beating a retreat; it reached the Ailette, and then changing front on the right threatened the *Chemin des Dames* to the E.; its right seized this redoubtable position after having crossed the Aisne; the Italian Corps under Albricci overcame all obstacles with great dash and reached the Ailette in its turn. On Oct. 12 the enemy



was surprised in the middle of his preparations for a retreat, which he had intended to carry out the following day. He was hustled without respite along all the front of the X. Army before he had time to complete the destructions which he had prepared. The St. Gobain massif was taken and Laon at last freed. The X. Army advanced 28 km. in 36 hours.

On Oct. 15 Gen. Mangin addressed his troops:—

"You have won the battle of the Ailette. On the N. bank of the Aisne the enemy waited for your attack after your victory at Soissons, and he had withdrawn still farther his line of resistance. On the 17th and 18th you defeated his advanced posts; and then on the 20th, after your strong artillery had been brought up, you defeated him on the field of battle which he had selected himself; you have pursued him beyond the Oise and the Ailette. After the 20th of August, the struggle became fiercer, the front facing E., for the conquest of those plateaux which overlooked Soissons. It was necessary to conquer them step by step after having crossed the Aisne and the Ailette by means of force. There you defeated the best divisions of the German army, who exhausted themselves in defending the approaches to the Hindenburg line. On September 14th, the Lauffaux mill was carried by assault and the Hindenburg line crumbled right up to the Ailette on an 8-kilometre front. In vain did the enemy, by bloody counter-attacks, attempt to retake that important position. You have not ceased to advance and have driven him back, compelling him to abandon the line of the Vesle. On October 1st, after you reached the Chemin des Dames, he has been forced to retire, in front of your left, to the Ailette. In the meantime the victorious advance of the Allied armies on your right and on your left threatened the communications of the German armies in position before you and they had to withdraw. You were waiting for this moment, on October 12th, surprising once more the enemy in the very act of moving. With your right and centre you crossed the Ailette, and with your left you seized the borders of the St. Gobain forest, and with a single bound, breaking the resistance of the rear-guards and then hustling them, you have covered 28 kilometres in 36 hours. This was done fighting and in spite of forests and marshes and a most thorough destruction of roads and bridges. You have captured 26,000 prisoners, more than 400 guns and an immense quantity of war material that can never be replaced. Laon, ancient city of communal freedom, and 10,000 French whose joy is for you a wonderful reward, have been freed from the most terrible slavery that has ever weighed upon the human race. The pressure of the adjoining armies has caused the enemy to retreat before you; the position which you have just taken forces the enemy to retire before them. Thus the hour of deliverance and justice draws near, with the punishment of the perjured, shameless thieves, murderers of our wounded, butchers of women and children, who must expiate their crimes and build up with their hands the ruins brought about by their insensate ferocity. But you have done nothing since. There remains more for you to do, as the sacred soil of our country is still fouled by the unclean foreigner, as thousands of Frenchmen are still in slavery, and since the world is awaiting its salvation through your courage. Soldiers of Freedom! Forward!" (C. M. E. M.)

**CHANTAVOINE, HENRI** (1850-1918), French man of letters (see 5.847), died at Galiure (Rhône) Aug. 15 1918.

**CHAPLIN, HENRY CHAPLIN, 1st VISCOUNT** (1842- ), English statesman (see 5.852), was generally welcomed on his return to the House of Commons in 1907 as a type of parliamentarian fast disappearing. He intervened with effect on questions of land and of social and tariff reform, but otherwise was not so prominent in debate as in past years. As a thoroughgoing Tariff Reformer, he deplored the change of policy with regard to food taxes which was forced on the Unionist leaders in the winter of 1912-3. When the first Coalition Government was formed in May 1915, he was left the solitary conspicuous Unionist on the Opposition front bench; and it was felt to be a fitting close of a distinguished career in the Commons when at the age

of 75 he was raised on the recommendation of that Government to the peerage in April of the following year.

**CHARLES** (KARL FRANE JOSEF) (1887- ), Emperor of Austria and King of Hungary from 1915 to 1918, was born Aug. 17 1887 at Persenbourg in Lower Austria. His father, the Archduke Otto (1869-1906), the younger brother of the Archduke Francis Ferdinand, was a clever man of easy morals; his mother, Princess Maria Josepha of Saxony (1867- ), was a zealous Catholic. Charles spent his early years wherever his father's regiment happened to be stationed; later on he lived in Vienna and Reichenau. He was privately educated, but, contrary to the custom ruling in the imperial family, he attended a public gymnasium for the sake of demonstrations in scientific subjects. On the conclusion of his studies at the gymnasium he entered the army, spending the years from 1906-8 as an officer chiefly in Prague, where he studied law and political science concurrently with his military duties. In 1907 he was declared of age and Prince Zdenko Lobkowitz was appointed his chamberlain. In the next few years he carried out his military duties in various Bohemian garrison towns. At that time no opportunity was given him of gaining a closer insight into affairs of State, although the death of his father in 1906 and the renunciation by his uncle, the Archduke Francis Ferdinand, on the occasion of his marriage with the Countess Chotek, of any right of succession for the children of this union, made him heir presumptive to the Emperor Francis Joseph. In 1911 he represented the Emperor at the coronation of King George V. in London. In October of the same year he was married at Pinerole (Italy) to the Princess Zita of Bourbon-Parma. Of this marriage, which is everywhere described as a happy one, there were several sons and daughters, the eldest of whom, Otto, was born in 1912.

Charles's relations with his great-uncle, the Emperor, were not intimate; and those with his uncle Francis Ferdinand, the heir to the throne, not cordial, the differences between their wives increasing the existing tension between them. For these reasons Charles up to the time of the murder of Francis Ferdinand, obtained no insight into affairs of State, but led the life of a prince not destined for a high political position. It was only after the death of the Archduke Francis Ferdinand that the old Emperor, moved by an innate sense of duty, took steps to initiate the heir to his crown in affairs of State. But the outbreak of the World War interfered with this political education. Charles spent his time during the first phase of the war at headquarters at Teschen, but exercised no military influence.

In the spring of 1916, in connexion with the offensive against Italy, he was entrusted with the command of the XX. Corps, whose affections the heir to the throne won by his affability and friendliness. The offensive, after a successful start, soon came to a standstill. Shortly afterwards Charles went to the eastern front as commander of an army operating against the Russians and Rumanians. On Nov. 21, the day of his great-uncle's death, he succeeded to the throne.

Seldom has a ruler on ascending the throne been faced with a more difficult situation. The struggle between the nations had been going on for more than two years; for more than two years the troops of the monarchy had been fighting heroically against the superior forces of their enemies. The military and economic resources of the monarchy were beginning to fail. Behind the front, especially in the towns of Austria, there was want of the necessities of life, and already it was clear that anti-dynastic feeling was spreading widely, especially in the non-Austrian and non-Magyar territories.

His programme on his accession was to combat this feeling, to renew the splendor of the dynasty, to give to the peoples under his rule the longest-for peace, and to bring about a settlement between the different nations composing the Habsburg Monarchy. But how was this programme to be carried out?

The Emperor Charles thought that for this purpose he needed new men; he therefore dismissed many of his predecessor's most influential advisers, and replaced them by persons from his own circle of friends and that of the late Archduke Francis

\*These figures indicate the volume and page number of the previous article.

Ferdinand, The *Oberstkofmeister*, Prince Montenuovo (1854- ), was superseded by the former president of the council of ministers, Prince Conrad Hohenlohe (1863-1920); the position of head of the military chancery, which had been held during the last years of the Emperor Francis Joseph by Freiherr von Bolfras (1838- ), was given to Field-Marshal von Marterer (1862-1919); Count Polzer (1870- ) succeeded Freiherr von Schiessl (1844- ) as head of the civil chancery, The Archduke Frederick, the commander-in-chief, was dismissed, the Emperor himself taking over the supreme command of the army, and headquarters were transferred from Teachen to Baden, near Vienna. Shortly afterwards Conrad von Hötendorf was replaced as chief of the general staff by Arz von Straussenburg. In the great offices of State there was also a change of personnel. The position of the Hungarian prime minister, Stephen Tisza, was indeed much too strong for his removal to be thought of at that time, and this was not effected till May 1917. But the Austrian prime minister, Ernst von Körber, was replaced by Count Clam-Martinitz, and the Austro-Hungarian foreign minister, Baron Burian, by Count Ottokar Czernin. These changes, however, were merely disadvantages, because the new men, with the exception of Czernin, could not free themselves from the traditional principles of government, while they lacked the experience of their predecessors.

The Emperor Charles himself had not the energy and strength of character necessary to carry out his views. Even his adherents while praising his powerful memory, his gift of rapid comprehension, his marked sense of the greatness of his House, his devotion to duty, and his personal charm, admit that he lacked the stronger qualities. His efforts for peace, which embroiled him with Germany, and his attempts to save the Habsburg Monarchy by concessions to the various nationalities composing it are described in the article AUSTRIAN EMPIRE (*Foreign Policy*).

During 1918 his attitude became more and more vacillating. Immediately after the capitulation of the Bulgarian army he announced that the various nationalities were free to sever their connexion with the monarchy, but on Oct. 16, in the hope of saving the dynasty, he issued a manifesto forecasting the conversion of Austria into a federal state, but with no mention of Hungary. This project also failed, the revolutionary elements having gained complete control in the various territories, and on Nov. 11 the Emperor, in order not to hinder the free development of his peoples, resigned all share in the government of Austria. Two days later he made a similar renunciation in the case of Hungary. The German Austrian Republic was proclaimed by the National Assembly on Nov. 12; the Hungarians at Budapest on Nov. 16. Yet Charles did not resign the crown of his dominions. He retired to his castle of Eckartsau on the Danube; thence he went on March 24 1919 to Switzerland, where he stayed first at Schloss Gstaad, and later at Prangins. His attempt at the end of March 1921 to secure his restoration as King of Hungary failed owing to the unfriendly attitude of the Hungarians and the unanimous opposition of the Succession States and the Entente.

A further and more serious attempt, on Oct. 22-24 1921, was defeated with fatal results to the ex-Emperor's chances of restoration. Having made a surprise air-flight with his wife from Switzerland to the Burgenland (where for some weeks a revolt had been organized against its transference to Austria), Charles was there joined by a small force of armed Royalists, at whose head he marched on Budapest. But the Allied Powers, as well as the "Little Entente," at once made it clear that a *coup d'état* would not be tolerated; and there was a strong rally at Budapest to the side of the Horthy Government. The Royalists, within 12 m. of Budapest, were met and defeated, with heavy losses, Charles and Zita being themselves arrested at Komorn. On instructions from the Powers, the definite deposition of Charles and renunciation of his claims to the throne were insisted upon, and he and his wife were handed over to the custody of the Allies for internment. With this dramatic failure was ended the hope of a restored Habsburg dynasty in Hungary.

**CHARMES, FRANCIS** (1848-1916), French journalist and politician, was born at Aurillac, Cantal, April 21 1848. He was educated at Aurillac, and afterwards at the lycées of Clermont-Ferrand and Poitiers, subsequently entering journalism. He rapidly made a mark as a brilliant writer, and in 1872 became editor of the *Journal des Débats*, where he remained until 1880, returning to it from 1889 to 1907. His political writings created much interest, and in 1880 the Government appointed him to the post of assistant director of the political department of the Foreign Office. In 1885 he became head of the department, and remained in the Foreign Office until 1889. From 1881 to 1885 and again from 1889 to 1898 he was deputy for Cantal, and in 1900 became a senator. Charmes is, however, best known for his connexion with the *Revue des Deux Mondes*. In 1893 he began his famous political writings in the *Revue*, and in 1907 became its editor. He takes a high place among the journalists of the third republic, and his articles and studies, both literary and political, in the *Journal des Débats* and *Revue des Deux Mondes* were one of the features of French literary history during the last years of the 19th century. He died in Paris Jan. 4 1916.

**CHARNAY (CLAUDE JOSEPH), DESIRÉ** (1828-1915), French traveller and archaeologist (see 5.947), died in Paris Oct. 24 1915.

**CHARPENTIER, GUSTAVE** (1860- ), French operatic composer, was born at Dieuze, Lorraine, June 24 1860. He received his musical education at the Paris conservatoire under Massenet, and obtained the Prix de Rome in 1887. His works include *Impressions fausses* (1895); *Impressions d'Italie* (1891) and the operas *La Vie du Poète* (1892); *Louise* (1900), which, first produced at Covent Garden in 1909, has attained a wide popularity, and *Julien*, as well as *Chant d'épithèse pour le centenaire de Victor Hugo*. He founded the Conservatoire de Mimi Pinson (for working girls), and during the World War started the *Œuvre de Mimi Pinson* and *Cocarde de Mimi Pinson* to aid wounded soldiers.

**CHASE, WILLIAM MERRITT** (1849-1916), American painter (see 5.956), died in New York, Oct. 25 1916. In 1912 he was awarded the Proctor prize by the National Academy of Design for his "Portrait of Mrs. H." At the Panama-Pacific Exposition (1915) a special room was assigned to his works.

**CHEMICAL WARFARE:** see POISON GAS.

**CHEMISTRY** (see 6.33).—A retrospect, in 1921, of the further advances made in chemical science, brings to mind that it was only in 1876 that the final paragraph of the article on Chemistry in the 9th ed. of the *E.B.* referred to the then quite recent establishment of the periodic law as marking a new era. In that article the elements were dealt with in groups, in accordance with their periodic relationships. In 1902, in the supplementary article published in the 10th ed., stress was laid on the uncertainties which still attended the attempt to classify the elements. Subsequent progress has been astounding, so much so that chemistry appears, during 1905-20, to have entered upon yet another era. New methods have been introduced and a degree of certainty has been given to the primary postulates of the science, even within living memory, which could not have been contemplated as within the bounds of attainment; at the same time, old suspicions have been justified and conceptions which had long been entertained have been realized. The advance is mainly the outcome of studies in the borderland region between chemistry and physics and is due to much overlapping of inquiry.

It is always interesting to trace events to their causes. A name to be written large on the page of advance is that of the late Sir William Crookes, whose casual observation (about 1861) of a peculiar behaviour of his vacuum balance, when determining the atomic weight of the element thallium, caused him to study heat-radiation effects in low vacua and led to the invention of his celebrated radiometer (1874). He thus became interested in the improvement of the vacuum pump and was led on to pay special attention to the negative or cathode electric discharge in high vacua. His results attracted attention owing to the beauty of the demonstrations he gave; he was himself sufficiently convinced of their novelty to regard the cathode discharge as consisting of

matter in a fourth state previously unrecognized (1879). The fundamental character of the discovery was not realized, however, until it was interpreted by Sir J. J. Thomson (1897), after Röntgen (1895) had shown that peculiar pulsations (X-rays) were excited by the impact of the discharge against a solid surface.

From 1852 onwards, the year in which Frankland first made known the simple theory of atomic valency upon which hitherto all structural formulæ have been based, chemists spent laborious days in verifying the Daltonian theory of atoms, itself a most wonderful prediction of genius. They have been engaged in defining atomic properties and in the comparative study of the elements; also they have been at infinite pains to elucidate molecular structure, in the hope of explaining the properties of compounds generally in terms of such structure. The work done is of colossal proportions. Success was attending their efforts in most directions; and a finished stable system was almost in prospect, when, with little notice, although the storm had long been brewing, their peace of mind was disturbed by the rudest possible intrusion from the side of physics. It is true that a note of warning came through the discovery of the radio-active properties of uranium by Becquerel; but it was not until the high-explosive shell radium was let loose that all preconceived views of atomic sanctity and sanity were scattered to the winds.

Although no one regarded the elements as strictly "elementary"—the only explanation of Mendeléeff's generalization was that they were genetically related and therefore of complex structure—it had always been supposed that they were infinitely stable, only to be decomposed, if at all, by resort to extreme measures. In radium, however, an "element" was suddenly found that was ever undergoing disruption and yet it was impossible to control its decay, either to hasten or diminish the rate. Even more marvellous was the character of the change—particularly as illustrating the dependence of molecular idiosyncrasies on structure. Radium is a metallic material, resembling barium the first weighty product of its slow spontaneous decomposition, together with the inert gas helium, was found to be a highly volatile and inert gas emanation now known as radium (or niton) having none of the properties of a metal; this latter, however, also underwent change and very rapidly, a helium molecule being again obtruded. This downward course was progressively continued, until at last what seemed to be lead was obtained.

Radium has been proved to be but a child of uranium, the most weighty of the known primary materials (238), though produced from it at a rate far slower even than that at which radium itself commits suicide. Thorium, the oxide of which plays so great a part as chief component of the "mantle" now generally used for incandescent gas-light, has also been shown to be a member of the Suicide Club (see RADIO-ACTIVITY).

Faraday, who early made clear the essential unity of chemical and electrical action, in the researches in which he laid the foundations of electro-chemistry, discovered that, in electrolysis, definite electric charges were carried by the moving atoms of matter; gradually the view grew up that the charge carried by the atom was related to the principal valency of the element. After a considerable interval, Helmholtz, in his Faraday lecture to the Chemical Society (1871), sought to draw the logical conclusion from Faraday's facts: he pictured chemical combination as the consequence of atomic charges of electricity and chemical interaction as involving the exchange and neutralization of such charges. Johnstone Stoney, in 1881, baptized these charges electrons. The hypothesis did not altogether satisfy chemists, more particularly on account of the strange variations in the valency of some elements and because it did not seem to afford an explanation of so-called residual affinity. The chemist, be it said parenthetically, ever has the feeling that the physicist and he are not in full sympathy and that the physicist has a tendency to treat the phenomena somewhat too broadly, if not superficially—to disregard the fine shades of difference which the chemist learns to evaluate through constant intimate intercourse with materials and his introspective habit of mind.

The electronic hypothesis only began to take firm hold of the imagination after Crookes had called attention to the special

properties of the negative electric discharge in high vacua, when Sir J. J. Thomson formulated the view that the Crookes cathode discharge was not particulate in the ordinary sense but composed of moving particles of electricity (electrons) little more than  $1/1,800$  of the mass of the hydrogen atom. Physicists tell us now that not only is matter atomic—which many scarcely believed 50 years earlier and electricity also atomic; but that atomic matter itself is made up of sub-atoms of electricity, and that, if the properties peculiar to the elements and peculiar to their compounds are to be explained, attention must now be turned to the determination of the electronic structure of the atom (see MATTER, CONSTITUTION OF).

Mindful of the long struggle he has waged in determining structure, the chemist foresees that it will not be an easy task for physicists to penetrate the mysteries of sub-atomic structure by experimental means and to arrive at a general agreement as to the validity of their conclusions. The new discoveries are such, however, as he has long awaited and he is profoundly grateful to his physicist colleagues for having taken up the quest at a stage beyond which he could scarcely hope to travel—the methods to be adopted, the kind of logic required, being so different from those proper to chemistry.

We cannot, in fact, overlook the differences which separate the practice of the different branches of science, nor can we disregard the existence of different types of mind suited to one or the other discipline. The line of demarcation, if not the stumbling block, is mathematics: the position of the chemist, in this respect, is midway between that of the physicist and the biologist. The popular saying, "too much learning has made him mad," may be paralleled by the statement that too much mathematics may deprive the chemist of his practical ability, especially of his constructive power; and mathematics seem to be anathema to the biologist and naturalist. Just as it takes all sorts to make a world, so it takes all sorts to solve the infinitely varied problems of science. The attempt to train all by similar methods is bound to end in failure; if it be persevered in, ultimately only the uneducated will be able to do original work.

The new discoveries are those, we say, that the chemist has long awaited. He has often speculated on the constitution of matter and supposed it to be built up of some primordial constituent. He has long thought that the elements are in some way genetically connected, on account of the striking "periodic" relationship they exhibit. He has not been satisfied with the weights he has been forced to assign to many atoms, feeling intuitively that it was not right that even an atom should be afflicted with a weight that had not the dignity of an integer—at least this has been an impression in the minds of those who were fully alive to the wonderful regularities and relationships manifest among the compounds of carbon. Lastly, he has also been prepared to believe that in some cases he might be dealing with mixtures almost impossible to separate: tellurium is a particular case in point, while nickel and cobalt afford another; probably something similar occurs in the case of chlorine.

The facts, however, go beyond all dreams. As the study of the products of radio-active change proceeded, it became necessary to recognize that although each had peculiar radio-active characteristics, the products in a number of cases were not distinguishable chemically; gradually the conception grew up of elements differing in atomic mass but indistinguishable chemically—termed isotopes by Prof. Soddy.

The constant presence of lead in radio-active minerals of various geological ages containing uranium led Boltwood to suggest that lead was probably the ultimate product of spontaneous breakdown in the uranium-radium series. Soddy, speculating on the position of the radio-active elements in the periodic system, came to a similar conclusion as to the origin of the lead in thorium minerals; but on this assumption it appeared probable, taking into account the reduction in atomic mass at the several stages, that the leads from the two sources would be homologous (isotopic). The atomic weight to be expected was in the one case 206, in the other 208. Examining thorium-lead, Soddy and Hyman found the value 207.7, whilst common lead gave 207.2.

T. W. Richards and others carried out similar observations with leads separated from uranium minerals; and from these obtained the low value of 206.05. In another case, Sir J. J. Thomson was led by an entirely special method to conclude that neon was a mixture of two gases; Mr. Aston then succeeded in separating the gas, by diffusion, into two portions differing slightly in density (*see GASES, ELECTRICAL PROPERTIES OF*).

Sir Joseph Thomson's method involved the projection at a photographic plate of molecules carrying a positive charge of electricity, moving with great velocity. Molecules carrying the same charge but differing in mass produced tracks on the plate more or less apart. Mr. Aston developed the method: subjecting the charged particles to the controlling influence of an electric as well as of a magnetic field, he was able so to focus the rays upon the sensitive plate that they produce sharply defined spectra; from the position of the lines it is possible to deduce the masses of the exciting particles. His results are more than remarkable. In the case of chlorine, the chief line is in a position exactly corresponding to that of a molecule of mass 35, a line of less intensity appearing at 37; the hitherto received weight of chlorine being practically 35.5, we have to suppose that the gas is a mixture of two kinds of molecule in the proportion of about 3:1. Bromine (79.92), strange to say, appears to be a mixture in about equal proportions of molecules relatively of mass 79 and 81. Fluorine and iodine, however, behave as simple species.

*Atomic Numbers.*—Before discussing the bearing of these astounding developments, it is necessary to consider another advance, that made by Moseley—whose death in the World War was one of the most irreparable of British losses—in the discovery of a method of determining the order of succession of what must now be spoken of as atomic species.

The X-rays are regarded as vibrations set up by the impact of the electrons upon material surfaces, the character of the rays being determined by the nature of the material which is bombarded. Moseley's method involved the study of the X-ray spectra of the elements; these he found were characterized by an orderly progression from element to element, so that it was possible from the spectra to arrange them in true order and even to foresee gaps. The spectra are simple and the relationship between successive terms is unmistakable. The numbers indicative of the place of an element in the successional series are spoken of as atomic numbers. The unfilled gaps seem to be few. We have to recognize 92 species of elements; of these only five are missing—numbers 43, 61, 75, 85, 87.

These results are a complete vindication of the policy long followed by chemists of classifying the elements in accordance with the periodic law of Mendeléeff. Tellurium, it had always been insisted, must be placed in the oxygen-sulphur series, in advance of iodine. The "number" assigned to tellurium is 52, which places it in advance of iodine (53), although the accepted atomic weights are 127.5 and 126.92. Now that iodine is regarded as whole, it may safely be predicted that tellurium is a mixture of homologues; an infra-tellurium has yet to be discovered. In like manner, cobalt has always been ranked before nickel, although the atomic weights were against this order; the atomic numbers they have received (17 and 18) are in accordance with this view. Recently Mr. Aston has obtained evidence that nickel has two constituents, one of mass 68, the other of mass 70; the intensity of the spectral lines are approximately as 2:1, in accordance with the atomic mass (68.68) hitherto assigned to nickel.

Assuming Moseley's generalization to be correct and that our knowledge of elementary species is nearly complete, it is possible

*Genetic Table of Elements*

1. Hydrogen

1.008

0

2. He 4	3. Li 6.94 (7-6)	4. Be 9.1	5. B 10.9 (11, 10)	6. C 12	7. N 14.01	8. O 16	9. F 19
10. Ne 20.2 (20, 22)	11. Na 23	12. Mg 24.32 (24, 25, 26)	13. Al 27.1	14. Si 28.3 (28, 29)	15. P 31.04	16. S 32.06	17. Cl 35.46 (35, 37)
18. A 39.88 (40, 36)	19. K 39.1 (39, 41)	20. Ca 40.07	21. Sc 44.1	22. Ti 48.1	23. V 51.06	24. Cr 52	25. Mn 54.93 26. Fe 55.85 27. Co 58.97 28. Ni 58.68 (58, 60)
	29. Cu 63.57	30. Qu 65.37	31. Ga 69.9	32. Ge 72.5	33. As 74.96	34. Se 79.2	35. Br 79.92 (79, 81)
36. Kr 82.92 (78, 80, 82, 83, 84, 86)	37. Rb 85.45 (85, 87)	38. Sr 87.83	39. Yt 88.7	40. Zr 90.6	41. Nb 93.5	42. Mo 96	43. _____ 44. Ru 101.7 45. Rh 102.9 46. Pd 106.7
	47. Ag 107.88	48. Cd 112.4	49. In 114.8	50. Sn 118.7	51. Sb 120.2	52. Te 127.5	53. I 126.92 0
54. Xe 130.2 (129, 132, 131, 134, 136)	55. Cs 132.81 0	56. Ba 137.37	57. La 139 58. Ce 140.25 59. Pr 140.6 60. Nd 144.3 61. _____ 62. Sa 150.4 63. Eu 152 64. Gd 157.3 65. Tb 159.2 66. Dy 162.5 67. Ho 163.5 68. Er 167.7 69. Tm 168.5 70. Yb 173.5 71. Lu 175	72. Kt	73. Ta 181.5	74. W 184	75. _____ 76. Os 190.9 77. Ir 193.1 78. Pt 195.2
	79. Au 197.2	80. Hg 200.6 (6) 197 to 204	81. Tl 204 (various radio elements)	82. Pb 207.2 206, 208 (various radio elements)	83. Bi 208 (various radio elements)	84. Polonium (various radio elements)	85. _____ (various radio elements)
86. Nt 222 (Th Em 220 .Ac Em 218)	87. _____	88. Ra 226 (Th X 224 Ac X 222)	89. Ac 226 (Ms Th II 228)	90. Th 232.15 (various radio elements)	91. U X 2	92. U 238.2 (U II 234)	

to discuss the classification of the electro-primary species with a far greater degree of certainty than heretofore. One fact is clear—that a periodic arrangement was never more justified: formerly this involved placing them in the order of the magnitude of their atomic weights and a sub-grouping under families; there was no means of determining whether or no unassigned numbers were or were not those of missing elements.

We are now on surer ground, as we may substitute atomic number—the integer indicative of place in the evolutionary series—for atomic weight: it were better perhaps to speak of this as the species number. In addition, we have to recognize the existence, within some species at least, of sub-species or varieties differing in atomic mass but in other respects, as a rule, so similar as to be indistinguishable except by special methods. These are the so-called isotopes. In the "isotopic elements," apparently, we are dealing with substances which are closely related in electronic structure, corresponding to the terms in a series of homologous organic compounds.

No precise distinction can be drawn between the terms "chemical" and "physical"—the chemist has availed himself so fully of physical methods that he has made them his own and has difficulty in giving any precise meaning to the expression "chemical property"; nevertheless, it has a clear connotation in his mind. The initial and second terms of the great series of paraffin hydrocarbons, methane ( $\text{CH}_4$ ) and ethane ( $\text{C}_2\text{H}_6$ ), are, chemically speaking, identical; indeed this is true of the entire group, putting structure aside: the differences are mainly physical—in mass, molecular magnitude, density, boiling point, etc.

In the accompanying table the electro-primaries are classified "periodically," in accordance with their "affinities." It is a striking fact that when arranged in the order of their "species numbers" they fall into eight great families: but progression is not along a continuous spiral. When the 25th place is reached, there is a precipitate fall through 26, 27 and 28; the series is then continued on the descending spiral until a similar precipitate fall takes place at 43 through 44, 45 and 46; again the progression is orderly until at 56 there is an astounding drop to 70; after a short interval, at 75 there is another fall similar to the first and second; during the remaining interval, progress is uniformly on the spiral. The species numbers, in some cases at least, serve but to indicate pockets in which homologues may be stored.

The view which was coming into favour in 1921 involves but an extension of the often discussed century-old hypothesis of Prout, that the elements are all multiples of hydrogen. It has long been held that the ratio of hydrogen to oxygen is 1:008:16, not 1:16; not only is this confirmed by Aston's observations but his measurements seem to justify the conclusion that integral values are to be assigned to all the electro-primaries other than hydrogen (cf. Aston, *Jour. Chem. Soc.*, 1921). It is also a striking fact that no evidence of the existence of variants has been obtained in respect of species the determined atomic weight of which is not an integral value within the probable limits of error. Thus no evidence of the existence of variants is forthcoming in the case of helium, carbon, nitrogen, oxygen, fluorine, sodium, phosphorus and sulphur; but lithium, boron, neon, magnesium, silicon and chlorine are each to be regarded as a mixture of one or more varieties of a single species. The absolute departure, however, from a whole number is no greater for lithium (6.94) than for sulphur (32.06), though in the latter case the difference is a much smaller proportion of the whole: sulphur is evidently a material to be further studied from this point of view.

The extent to which the accepted "atomic weight" differs from a whole number is no indication apparently of the values of which it is an integration. Thus lithium (6.94) appears to consist mainly of a constituent of mass 7 with only a small proportion of one of mass 6; but bromine (79.92) is a mixture in nearly equal proportions of variants of mass 79 and 81; still more remarkable is the composition of mercury (200.6), which appears to consist of 6 variants differing in mass from 197 to 204: krypton and xenon are of like complexity. Apparently the weights of separate species do not overlap. That phosphorus should be without variants and of mass 31 is remarkable, in view of the difference

of 16 units between many of the superposed terms in the first and second lines of the table—it would have been less surprising had it proved to be a mixture of units of mass 30 and 32.

The table has other noteworthy features. The members of each of the three metallic triads, on the short precipice faces at the right of the table, might be placed in line and the arrangement would have the advantage of bringing out the homology between their corresponding successive terms Fe, Ru, Os; Co, Rh, Ir; Ni, Pd, Pt. The arrangement has the advantage of being parallel with that which must be adopted in the case of the great group of rare-earth primaries—these cannot be entered across the table—if this is, in any way, to be a picture of the homologies manifest among the primaries. Maybe when this rare-earth group is fully studied, rhythmic variations such as are apparent in the three groups of triads will also be made obvious. It is noteworthy that, of the five presumed missing links in the record, two occur above the platinum triads in positions similar to that manganese has at the head of the iron triad; the third absentee may presumably also belong to the same great family and may well be a radio-active halogen. The fourth gap is in the rare-earth series; the fifth is in the radio-active region.

The classification of Cu, Ag, Au along with the alkali metals, still more that of the iron and platinum triads along with the halogens, may well seem peculiar; but in comparison with the astounding difference in properties between radium (a metal) and the emanation from it (a very volatile inert gas) the differences are not surprising. We may well be dealing with collaterals.

The arrangement is comparable with that of hydrocarbons in great families under the empirical symbols  $\text{C}_n\text{H}_{2n+2}$ ,  $\text{C}_n\text{H}_{2n}$ ,  $\text{C}_n\text{H}_{2n-2}$ , or in a series and in that formed by benzene, naphthalene and anthracene. In the  $\text{C}_n\text{H}_{2n}$  series, for example, the unsaturated ethenoid, hexene, is included together with the saturated hexamethylene (hexahydrobenzene). Benzene itself is usually non-valent but may act as a dyad, tetrad or hexad. Hitherto such variations appeared to be striking when observed among the "elements"; now that these are proved to be structurally complex, we may look forward to the explanation of their functional and physical peculiarities as consequences of structure, precisely as in the case of organic compounds: why some are metals, others non-metals; why some metals are good and others bad conductors of electricity; why some species are coloured, others colourless; why some species, notwithstanding their great mass, are so remarkably volatile—for example, mercury and, most strange of all, the "emanation" from radium—as in organic compounds variation in volatility corresponds very nearly with that of mass. Light may also be thrown upon the special properties of compounds such as carbonic oxide and nitric oxide.

As the interest attaching to the correlation of function with internal structure is now so great, attention may be called to a few special cases in which the structure may be supposed to alter.

A phenomenon which has attracted great attention, in carbon compounds, is that of metameric (isodynamic) change, one of the earliest and most interesting cases observed being that of ethylic acetoacetate, which, according to circumstances, functions in two distinct ways, in correspondence with either the one or the other of the two formulae— $\text{CH}_3\text{CO}\cdot\text{COOEt}$  or  $\text{CH}_3\text{C}(\text{OH})\cdot\text{COOEt}$ . It has often been supposed that these are but two reciprocal forms and that the molecule is subject to constant, spontaneous, oscillatory change; the evidence is convincing, however, that like all other cases of chemical change, the alteration is the outcome of a more complex, reversible process conditioned by a conducting impurity. Thus  $\text{CH}_3\text{CO}\cdot\text{COOEt} + \text{HX} \rightleftharpoons \text{CN}_2\text{C}(\text{OH})\cdot\text{COOEt} \rightleftharpoons \text{CH}_3\text{C}(\text{OH})\cdot\text{COOEt} + \text{HX}$ . The two forms have been isolated and their stability shown to be a question of purity.

That alterations take place in internal electronic structure in simple compounds and even in "elementary" materials is already clear. Water affords one of the most striking examples, in the sudden large increase in volume which it undergoes on conversion into ice. Assuming that the molecules are close packed in crystals, the increase cannot well be supposed to be due to their arrangement in any "open" form in ice. Can it be supposed that the electronic systems "expand" in some way? What is most striking is the suddenness with which the change takes place, at a definite temperature or nearly so—for there is evidence that ice is present in water above the freezing point and also that ice contains water.

Evidence of "internal" structural change in elementary materials is to be found perhaps in the peculiar manner in which their heat-

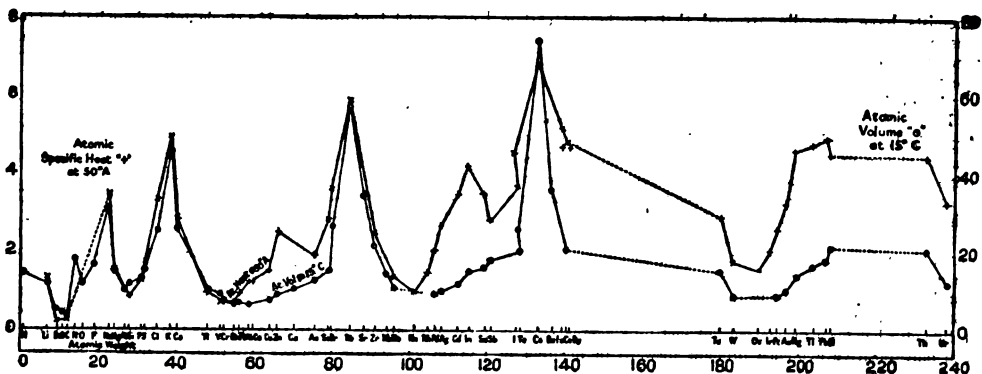

FIG. 1.

Diagram showing periodic variations of heat capacity and atomic volume.

absorbing capacity is dependent upon temperature. The amount of heat absorbed, by atomic proportions of a majority of the primaries, when their temperature is raised through a given interval, it is well known, is nearly a constant quantity over a wide range of temperature; only in the specifically non-metallic elements, silicon, beryllium, boron and carbon, is the departure from this "rule" at all considerable; and in the case of these, as the temperature is raised, the heat capacity increases, until towards 1,000° their behaviour approximates to that of the metals. It was long supposed, in fact, that there was a general tendency for the atomic heats to converge towards a constant value as the temperature was raised and to diverge as the temperature was lowered. Taking into account the fact that metals generally appear to be of simple molecular composition compared with the non-metals, it was not improbable that the differences were, in the main, differences due to molecular complexity; recent determinations of specific heat at the very low temperature of liquid hydrogen (50° absolute), by Sir James Dewar, have brought to light, however, the surprising fact that heat capacity is subject to periodic variation, much as the volume occupied by atomic proportions varies even at ordinary temperatures. The two properties are contrasted in the accompanying diagram.

The striking fact is brought out in this diagram that whilst the chemically most active metallic elements (the alkali metals) are but little affected, the best defined metals diminish in heat-absorbing power to a very marked extent.

The values deduced with the aid of ordinary materials, especially in the solid state, cannot be regarded as "atomic" in any proper sense of the term, as they are of different degrees of molecular complexity and the molecular complexity varies considerably with temperature. Thus a large number of the metals appear to have monatomic molecules, whilst there is reason to believe that those of the non-metallic elements, carbon especially, are of considerable complexity; but even in the case of the elements having monatomic molecules, intermolecular affinity is subject to great variation, being slight for example in mercury but considerable in the case of metals such as gold, silver and copper. In a complete theory of atomic structure, all these variations must be taken into account.

The correlation of molecular structure with function, in the carbon compounds, has been carried so far that the chemist has entire confidence in his conclusions—because of the large number of instances in which a comparison of fact with hypothesis can be made. The assumptions involved are few and it is more than remarkable that it should have been possible to erect so vast and complex a system upon so simple a foundation. The structural formulae of organic chemistry are to be regarded, however, mainly as condensed symbolic expressions, indicative of the general arrangement of the constituent radicles and of the functional behaviour of the compounds represented, not as absolute expressions of structure; indeed, it is becoming clear that the conventions which have hitherto sufficed should be modified in certain particulars to give fuller symbolic expression to the ascertained facts and to render the formulae more nearly a representation of the molecular architecture. In the case of the compounds of elements other than carbon, valid methods of determining structure are yet to be devised. It is surprising, to take an example, that we have no clear conception of the atomic arrangement of so simple and important a substance as sulphuric acid, H<sub>2</sub>SO<sub>4</sub>.

New methods of promise are coming into use, and it is to be expected that much will be learnt, especially by the study of the internal structure of crystalline solids, by crystallographic (geometric) methods and by means of X-rays—a field of inquiry opened up by Laue and then by the Braggs and others.

Frankland's original conception that the carbon atom has four affinities still holds the field. In modern times, it has been amplified by the introduction of space conceptions and the use of the tetrahedron as a model of the atom; in this way greater precision has been arrived at because of the limitations which are introduced. Perhaps the most important outcome of the hypothesis is, that whenever—but in no other case—a system is formed in which a single carbon atom is associated with four different unit systems, the complex may exist in two like asymmetric forms (of opposite character), distinguished by their power of influencing plane polarized light in opposite directions.

This conception of the carbon atom is entirely justified by the results of the analysis of the internal structure of the diamond by means of X-rays, carried out by Sir William Bragg and his son W.L. Bragg. The arrangement of the carbon atoms is such that every atom is the centre of gravity of four others arranged around it in tetrahedral fashion. Apparently there are definite sub-centres of force on the outskirts of an atom; in the carbon atom of which the diamond is composed, there is evidence of four such sub-centres arranged symmetrically—that is to say tetrahedrally. The atoms in the diamond form two sets; in each set the individual atoms present the same orientation and constitute a cubic space-lattice, but the orientations of the two sets are opposite. The effect of this difference is mirrored in the X-ray spectrum. This conclusion of the physicist is a complete justification of the views long held by chemists that the carbon atom has directed valencies and may give rise to asymmetric structures.

In the Bragg model of the diamond, although they are united similarly and symmetrically, in all four directions of trigonal axes, the carbon atoms can be allotted to similar sets of six, in each of which the individual atoms are united in the manner pictured by the chemist in the symbol of hexamethylene.

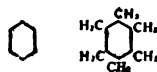

Although, in the diamond, the carbon atom is the physical unit or molecule, the molecule may equally well be regarded as indeterminate, indeed as cotermine with the mass, as the constituent units are uniformly related. As influencing our views as to the manner in which solids act in solutions and attract molecules of their own kind, it should be noted that each carbon atom at the exposed surface of the diamond mass has an affinity free.



Chemists have generally assumed that contiguous carbon atoms may be united in three ways, either by single affinities or by two affinities or by three affinities, leaving three, two or a single affinity free to unite with other radicles, thus—

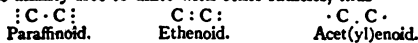

Accordingly in van't Hoff's spatial formulae, the two tetrahedra are shown united either (1) by two apices, or (2) edge to edge, or (3) face to face. The three forms of union have all been regarded as possible—in spite of the fact, that the assumption is made, that the four affinities of the carbon atom are exercised in the direction of four lines drawn from the centre of mass through the apices. It has been assumed that the affinities become more or less bent or stressed—as in von Baeyer's well-known hypothesis; hence the instability and attractive power of the so-called unsaturated compounds. In effect the existence of a difficulty has been recognized but met by a compromise.

The only positive evidence brought forward in disproof of Frankland's contention that two atoms may be united by more than single affinities, and that when each has several affinities not engaged by other radicles they mutually satisfy each other, is that advanced by Julius Thomsen in the fourth volume of his celebrated *Thermochemische Untersuchungen*. Thomsen argued, from his thermo-chemical data, that in ethenoid and still more in acetenoid compounds, the bond of union was weaker, not stronger, than that in the equivalent paraffinoid compound. He also maintained that the oxygen atom was not held by two affinities in keto—(CO) compounds; and he even threw doubt on the formulae assigned to ethylene oxide. Of late years, the chemist's peace of mind has been disturbed, and a suspicion created that all is not right with the symbolic system in use, by the discovery of unsaturated compounds in which the existence of single free affinities must seemingly be granted: Gomberg's triphenylmethyl,  $\text{C}(\text{C}_6\text{H}_5)_3$ , being one of the most striking and compelling cases which no structural sophist has been able to explain away. On paper it is all so easy, and chemists hitherto have been satisfied to work on paper to draw plans with the aid of certain conventions; now the time is at hand to attempt the representation of our ideas in the solid. There is reason to suppose that the study of solid structure, by geometric and X-ray methods in combination, may carry us over our difficulty.

Conflict must arise of the difficulty of interpreting the evidence. This is true already in one very simple case—that of common salt. The interpretation put on the results of X-ray analysis is that the chlorine and sodium units are so placed and so arranged relatively that there is no reason to believe in the existence of a molecular unit  $\text{NaCl}$ , within the mass. The chemist stands unconvinced before such a statement—he is not prepared to sacrifice the cherished convictions of a lifetime, not being satisfied that the new method is one in which implicit faith may be placed—the more as it has been shown, in the parallel case of potassium chloride, that a but slightly different arrangement of the units is required to give a geometrical structure, in entire harmony with all that is known of the geometrical and physical peculiarities of the crystal, involving no sacrifice of the chemist's view that the molecule  $\text{KCl}$  has separate existence (see Barlow, *Proc. Roy. Soc.*, 1914).

An attempt has been made, in recent years, to correlate outward form or crystalline structure with internal molecular structure, based upon the conception introduced by Barlow and Pope, that, in the case at least of the elements carbon, hydrogen, oxygen and nitrogen, the volume occupied by the atom, in any given compound under given conditions, is proportional to its valency, and that, when changes are effected in a molecule, the ratio is maintained constant although the actual volume may be changed. Taking into account the extraordinary number and variety of the compounds of these four elements, their marked stability and the ease with which interchanges can be effected within the molecules, this conclusion is all but unavoidable, but the solid models built up of spheres of volume 1, 2, 3 and 4, in accordance with such a valency-volume conception, have not answered expectation. A simple modification is possible, how-

ever, which is of promise: If a single unit sphere be taken to represent an atom of unit valency, such as hydrogen, atoms which are either di- or tri- or tetra-valent (oxygen, nitrogen, carbon) may be represented by models composed respectively of two, three, and four such spheres in close contact (of Barlow, *Proc. Roy. Soc.*, 1914, 91-16). Such complexes can be made into close-packed unlimited assemblages throughout which each sphere is in contact with 12 surrounding spheres; no such uniformity can be attained if the spheres differ in volume.

The adoption of the method indicated has important consequences. In the case of carbon, the atom is represented by four unit spheres the centres of which lie at the four corners of a regular tetrahedron. The four hollows on the four faces corresponding to the tetrahedron faces may be regarded each as the seat of an affinity; the union of two carbon atoms by single affinities, therefore, is to be represented by closely approximating two tetrahedral groups face to face, so that the three spheres of a face of the one tetrahedron key into the three hollows between three spheres of the opposed face of the other; the two atoms are thereby oppositely oriented. The eight sphere centres of the complex thus formed mark the angles of a regular rhombohedron, the shorter face-diagonals of which equal the edges. If two spheres representing an oxygen atom be attached to one of the faces, in continuation of the two lines of spheres forming a face, the model may be taken as that of ethylene oxide and it has the peculiarity that, whilst the twin oxygen spheres face the hollow in one of the two carbon pyramids, only one of them touches the other carbon pyramid at one of its apices. The condition is much that suggested by Julius Thomsen—certainly one of unsaturation. Such models can be made into close-packed assemblages of any dimensions, which is not the case when the models used are single spheres of varying volume. The adoption of such models has important consequences. In the case of carbon, the atom is represented by four unit-spheres piled in a pyramid. The four hollows on the four faces of the pyramid may be regarded each as the "seat" of an affinity; the union of two carbon atoms by single affinities, therefore, is to be represented by approximating two pyramids, face to face, rotating slightly, so that the three spheres of a face of the one tetrahedron fall into the hollows between the three spheres of the opposed face of the other; this is equivalent to setting one of the pyramids on its base and interlocking it with the second pyramid placed upside down.

The van't Hoff school has always assumed that the affinities act from the apices of the tetrahedra and have not taken the consequences of close-packing into account. One deduction from their assumption has been that single united carbon atoms are free to rotate—but this is not in accordance with the facts. To take only the case of the aldhexose sugars, of the form  $\text{COH}(\text{CH}_2\text{OH})_4\text{CH}_2\text{OH}$ . The four OH units in the four (CHOH) groups can be arranged relatively to the two terminal groups in eight different positions and each of the forms has its optical opposite. Fourteen of the sixteen compounds there foreshadowed are known and are stable substances. There must be at least one configuration of principal stability in such a system and if singly bound carbon atoms were free to rotate, a tendency to pass into this stable form should be in evidence. Nothing of the kind is observed: on the contrary, when change takes place it is confined to the part of the system that is directly attacked. The tetra-sphere model of the carbon atom does serve to bring out a certain face-grip between the two united carbon atoms.

By placing tetra-spheres together, in face contact, in the manner described, endless chains may be formed and it is conceivable that the carbon atoms in the paraffinoid hydrocarbons are arranged in rectilinear columns presenting similar parallel sections. It is, however, possible that, under some conditions at least, as in the hexose sugars, there may be a tendency to form condensed systems or rings: peculiarities in the optical behaviour of compounds containing paraffinoid side chains have been noticed which seem to favour such a conclusion, change proceeding regularly and uniformly, from atom to atom, as the chain is increased in length but a different peculiar value is observed at the fifth carbon atom and at each subsequent fifth atom. It is



must be in some of the electronic systems within the molecules; obviously, when the oxygen in no way has its attention engaged by hydrogen, its influence must in some way be felt more in the neighbouring carbon system; these, however, are dynamic changes, not evident in a model. The limitation is one to which our structural formulae have always been subject.

Whatever be the distribution of affinity in the carbon atom, in compounds it appears to be greatly modified, so that structural models, like structural formulae, must be interpreted with caution: To take a simple case, the change from benzene to hexamethylene seems to involve merely the addition of six more hydrogen atoms at the periphery, not the direct neutralization of the two sets of three affinities at the free carbon surfaces.

This pulling down of the affinities into two planes seems to be a general rule. Mr. Barlow finds, for example, that the model of tartaric acid constructed on this principle is in absolute accord with the crystallographic peculiarities of the acid.

Fig. 2 shows front and back views of the arrangement of the units in glucose,  $C_6H_{12}O_6$ . The carbon units may be distinguished without difficulty as the grey spheres, the cross denoting the position of the pyramidal apices; the white spheres are the hydrogen units; the twin dark spheres the oxygen atoms. Each layer consists of a succession of rows of four spheres. The free carbon area is of considerable extent at both surfaces: it will be obvious that, if some degree of residual affinity were exercised over these areas, successive layers of molecules might well be attracted into position, if once a single layer were deposited, as in crystallization.

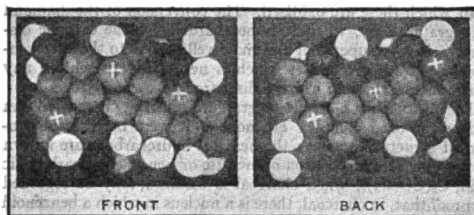

FIG. 2.

Front and Back Views of the Arrangement of Units in Glucose.  
(From *Journal of the Society of Arts*, Sept. 12 1919.)

**Chemical Change: Determinant and Catalyst.**—Although the subject of chemical change has been much discussed of late years, the chief advance has been in the attention paid to catalysts, which have acquired popularity owing to their use in a number of industrial processes. Although it is recognized that often some determining agent is required to condition an interaction, and the feeling is widespread that this is more generally true than has been supposed, the primary conditions of chemical change are seldom set forth; seldom is the practice departed from of using simple equations in which the two agents and the resultants alone appear, the need of a third substance being left out of account and unindicated.

The determining process is spoken of with increasing frequency as catalysis, the supposed agent being termed the catalyst. The conception was introduced by the great Berzelius in 1835, and was applied by him to such diverse changes as the hydrolysis of starch by acids and also by diastase; the oxidation of various substances in presence of platinum, especially when used in the finely divided state (platinum black); and the formation of ether from alcohol by means of sulphuric acid. Berzelius drew no distinction between interactions in solution and those in which solids such as platinum were involved. It is clear that he took an electro-chemical view of the process—his opinion being that the office of the catalyst is to awaken slumbering affinities through its presence and to determine a greater electro-chemical neutralization; probably no one has been nearer to our modern conception. Whether he had been in any way influenced by Faraday's electro-chemical researches of 1833-4 is not clear.

Now that it is so generally admitted that Faraday's dictum is to be accepted, that ordinary chemical affinity is a consequence of the electrical attractions of the particles of different kinds of matter and that the forces termed chemical affinity and electricity are one and the same, it may be asserted, as a necessary corollary, that the conditions which determine chemical action are those which determine electrolytic action.

Speaking generally, it may be affirmed that two substances cannot interact; a third must be present to determine the necessary slope of potential and flux of current. Thus zinc, whether highly purified or amalgamated, is all but unattacked by an acid, and it is logical to assert that, if pure, it would be unattacked; when coupled with an electro-negative inert conductor, it is dissolved, indeed, very rapidly, if the resistance in circuit be small. Or to condition attack, a depolarizer may be used, as in the case of copper, for example, which readily dissolves in dilute sulphuric acid in the presence of oxygen.

The rule appears to be that the three necessary factors must be conjoined in a conducting circuit; one of them must be an electrolyte; one of the remaining two and the electrolyte must be substances that can interact; the third may or may not take part in the chemical interchange—if it takes part, by acting as a depolarizer, it adds to the efficiency of the change, raising the electromotive force. Brereton Baker, in the course of his refined studies on the influence of water as a determinant of chemical change, has given abundant proof of the accuracy of the above-given definition, particularly by showing that a mixture of hydrogen and oxygen cannot be fired, even in presence of water; and that interaction takes place only when an impurity is present, which impurity, together with the water, forms an electrolyte. A trace of acid suffices.

Years before this result was obtained, it was possible to predict that water alone would not condition the interaction of hydrogen and oxygen—because it was not an electrolyte. It is true that this contention is not generally admitted—it is held that water *per se* has a slight conductivity; but this conclusion involves the unjustified assumption that Kohlrausch dealt with pure water and that the minimal conductivity which he observed was an intrinsic property of water. The course followed by Kohlrausch in purifying water, however, involving as it did nothing more than distillation within closed glass tubes, was by no means a refined one from our modern point of view; to assume that he had reached finality is absurd: it is impossible to obtain a vessel without surface impurity which is not open to attack; access of atmospheric impurity cannot be entirely prevented; further, some form of electrode must be used; pure water, therefore, will ever remain an ideal, and whilst it is logical to extend the curve representing the loss of conducting power, as the impurity is reduced, to zero origin, on no theoretical grounds are we called on to believe that it should come to rest short of this point.

Especially is this the case, in view of the conclusion of the dissociationist school, that in aqueous solutions the dissolved substance is alone resolved into its ions: muriatic acid, for example, is assumed to be a mixture of undissociated molecules of water with the separated ions, H and Cl. Unfortunately, the modern chemist too often lacks feeling for his material, and, without sympathy, understanding is impossible. It is impossible to put two so closely related and similar compounds as water ( $H_2O$ ) and hydrogen chloride (HCl) on the different planes they necessarily occupy, if the one be regarded as all but entirely stable and the other as entirely unstable.

That a profound chemical change takes place on bringing together the two compounds, hydrogen chloride and water, is beyond question. To regard the water as inert is impossible—if it were, the gas would not be so attracted as it is. Equations such as the following are not merely rational but necessary expressions in illustration of the changes that may occur:—

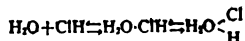

The part played by water in activating hydrogen chloride may be compared with that of magnesium in Hygnard's well-known

agent. No one assumes that in this agent alkyl and halogen are present in the state of free ions—they are dissociated but only in the sense that they are separately held by the metal. The forces of residual affinity have been entirely disregarded by the dissociationist school; and not being practised chemists, knowing nothing of the organic side, they have left facts out of account. The implications in Longfellow's lines, with reference to the sea—

Only those who brave its dangers  
Understand its mystery—

will ever be true and generally applicable. It is necessary to give this warning to the coming generation of workers.

Granted that the interaction, in the case of the formation of water from hydrogen and oxygen, be determined by the presence of an electrolyte (an acid impurity), is this to be thought of as the catalyst? *What is a catalyst?*

The definition of a catalyst which is generally current is that it is an agent which merely accelerates a change in being; but this is based upon the gratuitous assumption that two pure substances can interact. If this definition could be accepted, the acid impurity determining the rapid interaction of hydrogen and oxygen when a mixture is fired might be called the catalyst.

The issue is not quite so simple, however, since another class of activating agent has to be considered—namely the solid, such as platinum and the enzymes of natural occurrence. Hydrogen and oxygen at once interact when brought into contact with platinum black or with a "clean" platinum plate. Again, it is customary to think of the platinum only as the determining agent; there can, however, be no doubt that, in this case also, the electrolyte must be present. It does not seem probable that platinum in itself would form a conducting circuit with hydrogen and oxygen: if the two gases were condensed at its surface even to the extent of being liquids, these would be non-conducting liquids.

The probability of this view is enhanced when the nature of the process is taken into account and it is realized that the primary interaction is not even that of hydrogen and oxygen atoms but that, initially, the oxygen is converted into hydrogen peroxide, acting as "depolarizer" in an electrolytic circuit, whilst the hydrogen is "hydroxylated," as shown in the following equation:

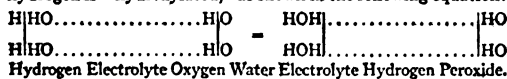

In the next change, the hydrogen peroxide acts as depolarizer, so that the reduction of the oxygen molecule is affected in two stages. According to this view, the electrolyte is the determining agent, the platinum exercising only an accelerating influence—if the definition of a catalyst as an accelerator be retained, the platinum rather than the acid is to be regarded as the catalyst.

Two other cases may be considered with advantage—(1) that of a ferrous salt in promoting oxidation by means of hydrogen peroxide; (2) the hydrolytic action of enzymes. Hydrogen peroxide has little effect as an oxidizing agent and probably, if it could be used in pure solutions, it would be without action; oxidation at once sets in on the addition of a trace of ferrous salt. Familiar cases are the liberation of iodine from iodides (rendered evident by the presence of starch) and the oxidation of tartaric acid to dihydroxymaleic acid (rendered evident by the appearance of a violet colour on addition of excess of caustic soda). What is the function of the ferrous salt—is it of such a kind that it is to be ranked as a catalyst? Its function would seem to be rather that of carrying the peroxide into action through the formation of a perhydro which can act as an electrolyte, thus—

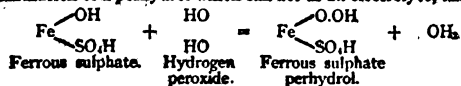

The case of the enzymes is more complex. These are all of natural origin and can only be judged by their actions. It is desirable to confine the term to hydrolytic agents.

Take the case of invertase, the enzyme present in ordinary yeast, which acts only on cane sugar and certain derivatives of

this sugar. Cane sugar is hydrolysed, more or less readily, by all acids, being converted into the two hexoses, glucose and fructose:—



It is similarly affected by invertase acting in a solution which is only faintly acid. Taking into account the amount of change effected by a small amount of enzyme compared with that effected by a relatively large amount of even a strong acid, it is clear that the enzyme is far more active than is any acid *per se*; it certainly, therefore, can be regarded as an accelerator rather than as a determinant of change. The minute amount of acid which appears to be necessary may be regarded as active in the same way that a trace of acid is active in determining the interaction of hydrogen and oxygen at a platinum surface.

The essential differences between the two classes of agent, the acid and the enzyme, become obvious when the rates at which action proceeds are contrasted. In any interaction occurring in an aqueous solution, such as that in which cane sugar is hydrolysed by an acid, so long as the solution be not too concentrated, the disappearance of water may be disregarded, owing to the relatively small extent to which it is withdrawn—so that only a single changing substance need be considered. In such a case, the amount of change, during each successive interval of time, is proportional to the amount of unchanged substance present. If say 10% disappear during the first period, 10% of the remainder will disappear during each successive period, i.e. 10, 9, 8.1, 7.29, during periods 1, 2, 3, 4, etc. The graph representing the rate of change is a logarithmic or exponential curve.

When cane sugar is hydrolysed by the enzyme invertase, the rate of change is of an entirely different order; within wide limits of concentration, well beyond the 50% limit, equal amounts are hydrolysed in each successive interval; the graph representative of the rate of change is, therefore, nearly a straight line. This behaviour is characteristic of enzymes generally, though in many the rate is modified fairly soon by the reversal of the change or otherwise. The same behaviour is met with in solid catalysts, e.g. the reduction of the fatty oils and of unsaturated compounds such as ethylic cinnamate (C<sub>6</sub>H<sub>5</sub>.CH = CH.CO<sub>2</sub>Et) and anethol (C<sub>6</sub>H<sub>5</sub>.C<sub>2</sub>H<sub>5</sub>.OCH<sub>3</sub>), by hydrogen in presence of finely divided nickel. Such results cannot well be explained except by the concentration of the interacting materials at the solid surface; as enzymes behave like nickel, they too must be thought of as acting in a similar way and as merely suspended in the liquid in which they are brought into action. This explanation is rendered the more acceptable by the fact that enzymes will act even when suspended in alcohol, in which they certainly are insoluble. It thus appears desirable to confine "catalyst" to particulate agents acting at surfaces of concentration, and to apply the term "determinant" to agents, such as ferrous sulphate or acids, acting under conditions of uniform distribution, in solution. The determinant may be said to be required in all cases, being the agent which constitutes the solvent an electrolyte. It is here assumed that no liquid *per se* is an electrolyte, excluding fused salts as liquids.

The assertion of the Arrhenius school that water—pure water—is very slightly dissociated and that it can by itself determine some slight amount of change, is neither logical nor rational. Water is one of the most protean of compounds and has properties which are altogether special. In considering the problems of particulate action, it is necessary that changes in water itself should be taken fully into account. Whilst it is admitted that water is a polymorphous substance and that we are not justified in assigning the simple formula H<sub>2</sub>O to the molecule except it be in the state of dry steam, there is no agreement as to the constitution of the liquid or of ice. To avoid confusion, it is well to assign a special name to the simple molecule: *hydrone*, proposed by H. E. Armstrong, appears to be appropriate, most in accordance with its neutral character and justified by analogy, its organic analogue being the ketone acetone, OC(CH<sub>3</sub>)<sub>2</sub>. The passage of water through its three states is too commonly represented as a series of physical changes; actually there can be little doubt, that a complex series of structural changes is involved. Accord-

ing to Tamman, ice can exist in no less than six forms, depending on the conditions of pressure and temperature. No substance can be studied better from the electronic standpoint.

On the ground of analogy, the chemist can foresee the existence of an active *Hydronol* and of a variety of neutral *Hydrones* corresponding to the paraffinoid polymethylenes, thus

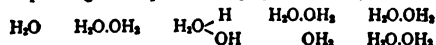

No valid method of determining the complexity of the molecules either of water or of ice is known; all that can be asserted is, that water especially must be a mixture and that its composition not only may but must be subject to considerable variation as the temperature is changed or substances are dissolved in it. Whatever the composition of the mass, at the surface, the simple molecules of hydronol ( $\text{OH}_2$ ) must be present in maximum proportion; and this will also be the condition at the surface of solid particles suspended in an aqueous solution.

As the most active solvent in water must be the hydronol molecules, in a solution in which fine particles are suspended the liquid layer at the fluid-solid interface should be more concentrated than the general body of the solution. Hence the special activity of enzymes and other particulate agents: apart from any special attractive influence exercised by the solid surface, the layer at the interface is likely to be specially active as a solvent.

The enzymes, however, exercise a selective activity which is altogether peculiar—each enzyme can induce the hydrolysis, if not of a single compound, at most of a set of structurally similar compounds. Thus the enzyme urease will act only on urea. Invertase acts only on cane-sugar or derivatives of this sugar in which its special structure is retained and only an addition made to the molecule.

In the case of glucose, a large number of compounds are formed by the introduction, in place of either the one or the other of two terminal hydrogen atoms, of some equivalent group. Two series of glucosides are thus produced, known respectively as  $\alpha$ - and  $\beta$ -glucosides. An enzyme is present in yeast (*maltase*) which will induce hydrolysis of all the  $\alpha$ -glucosides; the bitter-almond contains an enzyme which acts only on the  $\beta$ -compounds.

The only possible explanation of this behaviour seems to be that the enzyme is structurally related to the compound which it affects, so that it actually fits upon it and grasps it, as it were. This view involves the further assumption that the specific agent of change is also carried by the enzyme, as the amount of acid which suffices to determine the exercise by the enzyme of its maximum activity is so small that it scarcely seems probable that the rapid action is the consequence of the mere concentration of this acid together with the hydrolyte at the surface of the enzyme; nor is such an assumption compatible with the selective activity of enzymes. More probable is it that an acid radicle is operative which the enzyme itself carries, this being in such a position that it is brought into proximity with the attached molecule (the hydrolyte) at the point at which hydrolysis takes place—the acid which is added serving to maintain this radicle free and also acting as the necessary electrolyte, as in the case of platinum.

It should be added that, although platinum and similar catalysts are not structurally selective agents, their action is in some respects limited—as, however, is that of most chemical agents. Thus, whilst hydrogen and oxygen interact at a platinum surface, a mixture of carbonic oxide with oxygen remains unaffected; indeed, carbonic oxide interferes with the oxidation of hydrogen in presence of platinum; this behaviour, however, is perhaps less a consequence of the lack of affinity of carbonic oxide for platinum than of intrinsic peculiarities of the gas. Platinum and similar catalysts, especially nickel, have a very wide range of activity as hydrogenising agents.

The question remains—how is the action of platinum effected; is it merely a physical condensing agent or is it to be regarded as acting chemically? The view has long been held that it may combine with oxygen—if not with hydrogen—and that it promotes oxidation through the intermediate formation of an oxide.

Recently, Willstätter has shown that platinum and palladium are without action even as hydrogenising agents if they have been freed from oxygen. He advocates the view that a compound is formed, which is both hydride and peroxide, in which hydrogen is present in a more readily dissociable form than in the hydrides of the metals. Spongy platinum, prepared by reducing chloroplatinic acid with formaldehyde in presence of caustic potash, may be deprived of oxygen by suspending it in glacial acetic acid and passing hydrogen through the liquid, either in the course of 30 hours at atmospheric temperature or in 8 hours at 50° to 60°. Such a product is insoluble in muriatic acid and does not liberate iodine from an acid solution of potassium iodide; it will not condition the hydrogenation of benzene to hexamethylene, etc., but acquires the power when shaken, during a short period, with air. During hydrogenation, the catalyst invariably becomes deoxidized by the action of the hydrogen and needs revivification by oxygen. Willstätter suggests that the metal is converted into either the peroxide  $\text{Pt} < \begin{array}{c} \text{O} \\ \text{O} \end{array}$  or the corresponding perhydrol

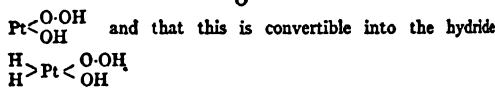

By this assumption, the activity of platinum in promoting oxidation is brought entirely into line with that of ferrous sulphate, which, it has been pointed out, is probably active as a perhydrol. Interesting light is also thrown on the hitherto enigmatic behaviour of haemoglobin, which combines directly with oxygen, forming oxyhaemoglobin, by the fact that the oxidized platinum catalyst may be deprived of its oxygen and rendered nearly inactive by continuous exhaustion with a high vacuum pump, the means by which oxyhaemoglobin may be entirely deprived of oxygen: the parallel is made all the more remarkable by the fact that the oxygen may be displaced from oxyhaemoglobin by carbonic oxide, which renders platinum inert towards hydrogen. Oxyhaemoglobin has a big molecule, as it is composed of a protein in association with haematin; if the oxygen be present in it, perhaps in combination with the iron atom, in the form of perhydrol and it acts in the blood corpuscle as a particulate agent, the remarkable oxidizing power of the blood may be reckoned among the actions promoted by catalysts.

It is customary to regard haemoglobin as a "colloid," but in using this term we are again in difficulty owing to the lack of a clear definition of its precise connotation. Latterly the word has been used almost as the synonym of the state of very fine sub-division—any substance present in suspension in a liquid in a very finely divided state has been spoken of as a colloid.

Originally this was not the meaning associated with the term by Graham, who introduced it and applied it generally to glue-like substances. He appears to have thought of the colloid as soluble but as merely opposite in the scale of solubility to the ordinary crystalline, more or less easily soluble substances of relatively low molecular weight—in fact, as a big, lumbering molecule, with slight affinity for the solvent and therefore ready to separate from it in the pectous or particulate form. Unfortunately, not only has the connotation of the term been altered but a confused language has grown up about the term which renders the consideration of the activity of substances in the particular state specially difficult. Far worse, the attempt has been made to constitute so-called Colloid Chemistry a separate discipline, the designation being arbitrarily confined to suspensions of fine particles varying from one thousandth ( $\mu$ ) to one millionth ( $\mu\mu$ ) of a millimetre in diameter.

If this definition be accepted, the "colloids," when separated, in the particulate state, from solutions should function as catalysts under favourable conditions; and this appears likely to be true. One of the few cases apart from the action of enzymes—which are selective catalysts—of a colloid having been shown to act specifically as a catalyst is in the production of hydrazine from ammonia, by the action of a hypochlorite, by Raschig's method, an interaction which is promoted by the addition of glue,

the amount produced being thereby much increased. In this instance, the catalytic effect may well depend upon the intermediate formation of a protein chloramine.

It is desirable here to call attention to certain peculiarities in the behaviour of enzymes which merit consideration in view of their action being that of particular agents. When submitted to the action of the enzyme urease—best used in the form of an extract of the soya bean—according to the amount of enzyme used, urea, for example, is rapidly hydrolysed, at a diminishing rate as the action proceeds. Contrasting the effect on a solution of moderate strength with that on a concentrated solution, it is noteworthy that the amount changed is considerably less in the latter: thus in an experiment in which grammic-molecular (6%) and five-grammic molecular (30%) solutions were contrasted, at the end of 10 hours, the ratio of the amounts of acid required to neutralize the ammonia formed was as 55 in the case of the stronger to 132 in that of the weaker solution.

Proof that the diminished activity of the enzyme is the consequence of the increase in the concentration is given by the observation that, if methylurea be, in part, substituted for urea, the amount of the latter hydrolysed is less than in the absence of the methylurea. Methylurea is not in the least affected by the enzyme, this being strictly selective in its action, attacking only urea, none of its derivatives.

Special reference is made to these observations as showing that in the case of catalysts generally the conditions at the surface cannot be considered independently of those in the medium. It is, however, to be noted that, even in simple solutions, in the case of interactions taking place under the influence only of determinants—in the absence of a catalyst, as defined in this article—the rate of change is not proportional to the concentration. This is seen at a glance on reference to the accompanying graph (fig. 3) representing results obtained on hydrolysing cane-sugar with nitric acid, the sugar being the only variable. Such variations are certainly due to reciprocal variations in solvent and solute as the concentration is changed.

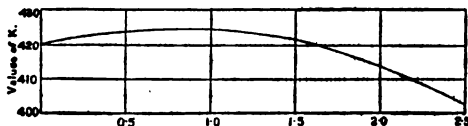

FIG. 3. Molecular Proportions of Sugar.

It is known that absorbents take up relatively more of a substance from dilute than from concentrated solutions. That the condition of "water" at a surface differs from that in the main body of the liquid seems also to follow from the observation that wet paper does not stiffen until the temperature is reduced to  $-0.1^{\circ}$  and that the water in a clay sphere does not freeze until  $-0.7^{\circ}$ . The observation made by Adrian Brown and Tinkler, that when barley corns are steeped in a 50% solution of acetic acid, the absorbed liquid ultimately in equilibrium with that outside the corn contains 80% of the acid, would seem to show that the "water" of the thin film distributed over the surfaces of the starch granules is more active than ordinary water. Substances so diverse and different from acetic acid as aniline and phenol behave in a similar way, accumulating in the capillary spaces. In the enzymes which act on carbohydrates, not only is the rate of change diminished by foreign substances generally but those which resemble the hydrolyte in structure exercise a retarding influence far in excess of neutral materials. Thus the hydrolysis of the glucosides, whether  $\alpha$  or  $\beta$ , is specially retarded by glucose, but not nearly to the same extent by the isomeric galactose. If the argument advanced above that the enzyme must fit the hydrolyte be accepted, it is obvious that a substance which could also be fitted upon the enzyme will necessarily interfere more with its activity than would a substance whose interference would be merely mechanical—by getting in

the way—or that of a solute modifying the osmotic condition. A special interference with enzymes and with other catalysts which function chemically, not merely as surface condensing agents, may arise through the neutralization of the functioning radical; hence perhaps the great influence of acids and alkalis. The accompanying graph illustrates the behaviour of urease

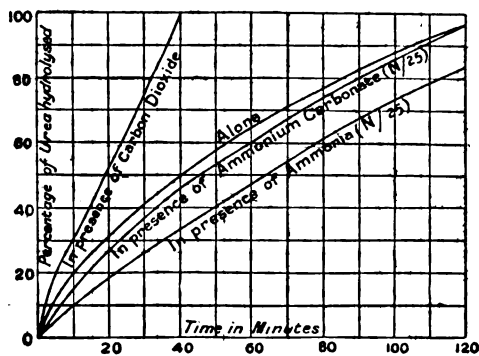

FIG. 4. Behaviour of Urease under Action of Enzyme.

when subjected to the action of the enzyme alone or in presence of either both or one or other of the products of change. Hydrolysis is retarded by the weakly alkaline mixed product of change. Taking the products separately, the more strongly alkaline product ammonia has a still greater retarding influence; on passing carbon dioxide into the solution, however, so that it is present in excess, the action of the ammonia is held more strongly in check and the action is greatly accelerated.

In the case of urea, under the influence of the enzyme, the interaction is complete—there is no reaction or reversal. This is theoretically wrong. Cane-sugar behaves similarly. In other cases, an equilibrium point is reached and the enzyme will act reversibly in a solution—if it be sufficiently concentrated—of the products of change, reforming the hydrolyte.

Thus  $\alpha$  and  $\beta$  methyl glucosides are resolved into methyl alcohol and glucose by the enzymes maltase and emulsin respectively; the resolution appears to be complete in dilute solutions but is less and less so the more concentrated the solution; and if a mixture of methyl alcohol and glucose in water be submitted to the action of either enzyme, the appropriate glucoside is reproduced in proportion to the concentration.

The behaviour of a fatty oil (olive oil) in presence of the enzyme lipase affords a particularly striking illustration of the manner in which change in the two possible but opposite directions is balanced as the conditions are varied. On reference to the accompanying graph it will be seen that as the amount of water present is increased the amount of fat hydrolysed is increased; as the fat and the fatty acid are insoluble, it is to be supposed that the water acts by diluting the glycerol and it will be noted that, if glycerol be added, the extent to which hydrolysis takes place is diminished.

The reason why urea and cane-sugar are not reproducible from the final products of change by the respective enzymes is not clear; it is not improbable that the final are not the initial products and that the initial products have but an ephemeral existence in solution: some link in the chain of change is lost by the occurrence of an action outside the range of the enzyme.

Urea is known to undergo change reversibly in solution into ammonic cyanate:  $\text{CON}_2\text{H}_2 \rightleftharpoons \text{NH}_4\text{NCO}$ . The proportion of cyanate present at ordinary temperatures is known to be very small; it is slightly increased by boiling the solution; if silver nitrate be added, which serves to fix the cyanate as insoluble silver cyanate, an almost complete conversion can be effected.



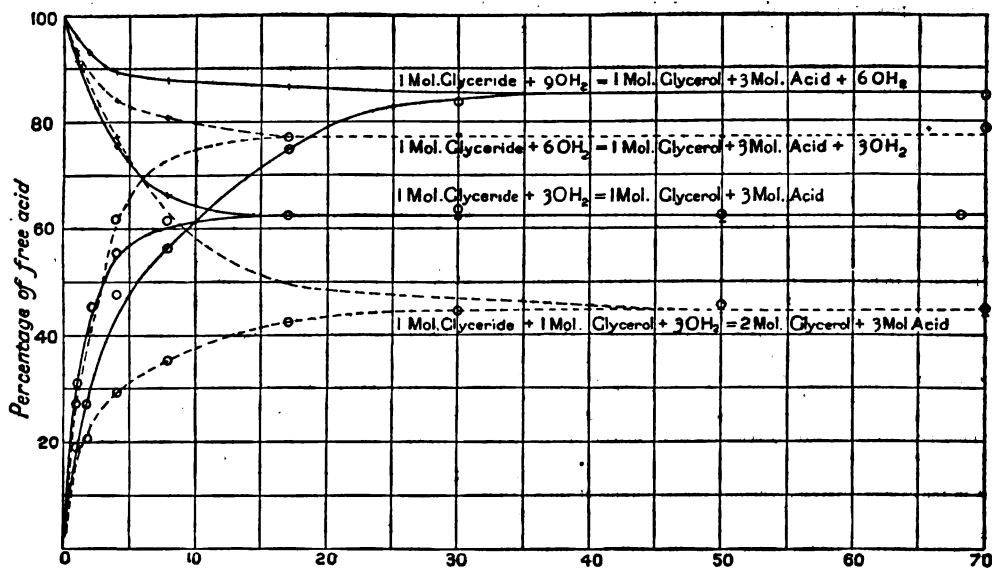

FIG. 5.  
Behaviour of Fatty Oil under Influence of Enzyme.

No evidence of the production of cyanate during the hydrolysis of urea by urease has been obtained.

It is of interest that, whereas ammoniac thiocyanate can be destroyed by bacterial action, thiourea cannot; this compound is not known to undergo change in solution.

Before leaving the subject of catalysts, the rusting of iron may be referred to as a case in which the action is influenced by a particulate agent. The subject is one of perennial interest and it is strange how slowly the nature of the process is appreciated. It must be electrolytic; the metal is attacked primarily in a circuit comprising the electro-negative conducting impurity present in all irons and the electrolyte on its moist surface, usually carbonic acid, the product being a soluble ferrous salt. If this salt remain at the surface, it necessarily undergoes hydrolysis yielding ferrous hydroxide, which is deposited as solid and sooner or later oxidized to a ferric hydroxide. J. A. N. Friend has recently advanced a "colloid theory" in explanation of the process. He shows that in moving water there is little rusting, though the iron is slowly dissolved—as must be the case on the above view. He considers that the ferric hydroxide precipitated on the surface under still conditions acts catalytically, by oxidizing metallic iron with relative rapidity and simultaneously undergoing reduction to a lower hydroxide, etc. It is well that this effect of once formed rust should be insisted on; but it stands to reason that it should act as an accelerator, by promoting, through the surface action of its fine particles, the condensation both of electrolyte and of oxygen, whether or no it act itself and be alternately reduced and reoxidized.

The part played by the determinant in gaseous interactions has yet to be appreciated. The results obtained by Bone and his co-workers at high pressures are specially significant. When a mixture of hydrogen and oxygen, diluted with nitrogen, is exploded, the pressure rises to a maximum almost immediately; if methane or carbonic oxide be burnt in place of hydrogen, the pressure developed rises to a maximum only gradually. The process of change must be far more complex in the latter cases. The slowness of the change, in carbonic oxide, may reasonably be ascribed to the prior conversion of the oxide into formic acid ( $\text{CO} + \text{OH}_2 = \text{H}_2\text{CO}_2$ ) before it is burnt (cf. *Trans. Roy. Soc.*, 1915, A. 215, 275).

Whatever the phenomena considered, if the view be taken that chemical change is essentially an electrolytic process, conclusions such as have been formulated cannot be avoided. The process, in the main, is the same in all cases. The "determinant" is the cause of change; when a catalyst is present, the rate of change is greatly accelerated, owing to the concentrating effect this exercises; maybe, in some cases, the catalyst is required together with the determinant to constitute a conducting circuit of the interacting materials.

It is strange that the action of the determinant is so much overlooked. Recent observations by H. B. Baker show that its influence is to be considered even in cases of chemical change not ordinarily regarded as such—the evaporation of liquids. Long ago it was proved by him, that not only do hydrogen chloride and ammonia not interact when dry but that the product of their interaction, ammonium chloride, does not decompose so readily, when heated, if dried. He now finds that as liquids, such as benzene and bromine, are rendered more and more nearly dry, the boiling point rises and at the same time the weight of the molecules in the liquid gradually increases. Strange to say, when shaken with water, the polymerized benzene only slowly passes back into the simpler state.

As the phenomena of chemical change are more and more closely examined into, the conviction grows that molecular structure and affinity are the determining causes; to correlate these with the electronic structure of the constituent materials is the difficult task of the coming generation. Why is carbon so entirely peculiar an element? Why has oxygen so remarkable an influence on the development of acidic qualities? An endless series of such questions may be asked. They must be answered in terms to satisfy the chemist—to satisfy his dynamic as well as his structural cravings, and to explain the many variations in function which follow from variations in composition.

A revolt is now setting in against the tendency to accept purely physical interpretations of chemical phenomena, which has so long been prevalent and has too often led chemists to overlook the complexity of the conditions prevailing in solutions. As a result, undue importance has been attached to mathematical agreements which it is clear have but served to give colourable expression to the facts; and the minute and penetrating analysis

to which phenomena should be subjected has been unduly discouraged. For example, the apparently physical phenomena of lubrication have been reduced by the observations especially of W. B. Hardy and of Langmuir to terms of chemical structure and of function as determined by molecular structure. A single layer of molecules is sufficient to cover and cloak a surface—a matter of importance to be borne in mind in considering the action of catalysts—and the disposition of the molecules is determined by their structure. Thus the spread of a liquid upon water is determined by the affinity of the substance for water but this is a localized function of its structure. Langmuir's measurements show that, in the case of the complex fatty acids, the molecules are to be thought of as having only the terminal carboxyl groups "dissolved" or dipping down into the water, the complex hydrocarbon group sticking up much as does a fisherman's boat. Molecules so placed, ranged side by side in piles, would present an upper surface composed of the terminal methyl groups ( $\text{CH}_3$ ).

W. B. Hardy's measurements show that the lubricating effect of substances is definitely a function of molecular structure; it therefore varies with the nature of the surface to which it applies, as both the affinity of substance to surface and intermolecular affinity are functions of the structure of the substances. Much has been done of late, especially by Jacques Loeb, to show that chemical conceptions can be applied in explanation of the peculiar "physical" properties of colloid materials and that the behaviour of these is comparable with that of crystalline materials when determined under proper conditions. The passage of colloid materials from the dissolved to the undissolved particulate state and the accompanying changes are certainly matters to be considered from the point of view above explained.

Most irregular results have been obtained by several workers who have studied the effect of different acids on various properties, such as viscosity and osmotic efficiency, of liquids containing gelatin or egg albumin; as a rule, acids have been used in equivalent concentrations, without taking their relative efficiencies into account. Loeb has shown that there is no difference in the effects of a variety of acids when the solutions of the protein acid are of the same acid efficiency (the same pH value) and the same concentration of the originally isoelectric protein. The same is true of alkalies. The proteins exist in three states, by derivation from the amino-carboxylic acids: either the molecule may be neutral or it may be either acidic or basic. Thus, if brought into contact with a salt at  $\text{pH} = 4.7$ , gelatin is neutral, but at  $\text{pH} < 4.7$ , it forms an acid salt, whilst if the  $\text{pH}$  be  $> 4.7$ , a metallic salt is formed.

Not only are more precise conceptions of the behaviour of colloids being formed by such studies but light is also being thrown on the characters of the acids. W. B. Hardy, in 1907, pointed out that the solvent power for globulin of strong and medium acids is measured by the number of gramme-molecules present, not by the number of gramme equivalents. He wrote  $\text{HCl} = \text{H}_2\text{SO}_4 = \text{H}_3\text{PO}_4$ ; adding, "very weak acids have a lower solvent power— $\text{HCl} = 5\text{HA} = 3000 \text{H}_3\text{BO}_3$ . These relations are explained by the very weak basic functions of globulin." Loeb has obtained results of the same order. Using gelatin and egg albumin, he has found that most acids act as monobasic molecules—not only phosphoric acid but also the organic dibasic acids, succinic and tartaric, even tribasic citric acid; oxalic acid, however, was intermediate in behaviour between the mono- and di-basic acids; sulphuric acid was definitely dibasic, serving to couple two molecules. That oxalic and the other organic acids should act as monoacids sulphuric.

The whole question of effective acidity is one requiring further study—it may be questioned whether any inorganic acid be more than monobasic in the proper sense of the term.

Benzenesulphonic acid ( $\text{C}_6\text{H}_5\text{SO}_3\text{H}$ ) and similar acids have about 90% of the hydrolytic efficiency of sulphuric acid; it would therefore seem probable that this acid is to be regarded as an unsymmetrical hydroxysulphonic acid rather than as  $\text{SO}_3 \begin{matrix} \text{OH} \\ \text{OH} \end{matrix}$  (cf. *Proc. Roy. Soc.*, 1914, 90, 73).

*Progress in Industrial Chemistry.*—Chemistry is a constructive as well as an analytic science, touching our life at every point. In it is embodied our knowledge of the materials of which the world consists and the office of its priests is to make clear the manifold activities of these materials. The science is fundamental to all our industries; the key to our own nature and acts may eventually be found within its precincts. How much our insight is deepening, our outlook widening, how much the science is gaining in precision, the previous sections of this article may have shown, in the following, the attempt is made to trace out the main lines along which specific advance is taking place.

The progress in industrial chemistry, in recent years, has been very marked. Even in the oldest of chemical industries, the heavy chemical trade, so called, which includes the manufacture of alkali and of sulphuric, nitric and muriatic acids, as well as bleaching-powder and soap, great changes have been effected.

Sulphuric acid has been made to an ever-increasing extent, especially since the outbreak of the World War, by the "Contact Process"—by associating sulphur dioxide directly with atmospheric oxygen, by means of a finely divided platinum used as a catalyst. When the usual raw materials were not available, a process was worked out, in Germany, in which calcium sulphate was roasted in a rotatory kiln, together with silica, clay and powdered coal—thus producing sulphur dioxide; the residue was used for cement manufacture.

During the war nitric acid was produced for the first time on a large scale by the direct oxidation of ammonia—again with the aid of platinum as a catalyst. The special factory erected for its manufacture was constructed in six months, at a cost, it is said, of £4,000,000. Another synthetic process of making nitric acid is that of Birkeland and Eyde, developed at Notodden, in Norway, since 1903, which involves the application, on a large scale, of Cavendish's fundamental discovery that nitric oxide may be produced by passing an electric discharge through air (see NITROGEN FIXATION). The world is, therefore, now independent of the natural supply of nitrate in the form of Chili saltpetre.

The manufacture of caustic soda and potash by the electrolysis of a solution either of salt or of potassium chloride, has been carried out on an ever-increasing scale; as a consequence, chlorine has been produced, in considerable quantities, together with hydrogen. More chlorine having been made than could well be used in the manufacture of bleaching-powder, the first steps have been taken towards preparing muriatic acid directly from chlorine and hydrogen. The production of chlorine, in excess of the normal requirements, was probably the primary cause of its use in the World War. Another consequence has been the introduction of a variety of chlorinated compounds, e.g. chlorinated ethanes and tetrachlorethylene, as solvents.

Even in the ammonia-soda process changes are foreshadowed. This process involves the treatment of a solution of salt containing ammonia with carbon dioxide and the production of sodium bicarbonate, together with ammonium chloride. The custom has been, after separating the carbonate, to recover the ammonia by distilling with magnesia, allowing the magnesium chloride to run to waste. Now that ammonia is likely to be procurable in large quantity, the more rational course would seem to be to separate the ammonium chloride as such and use this as an agricultural fertilizing agent in place of ammonium sulphate—thus saving sulphuric acid.

The manufacture of ammonia directly from atmospheric nitrogen and hydrogen, through the agency of a catalyst, under a pressure of between 200 and 300 atmospheres, has been carried out, on a large scale, in Germany, during several years past; in fact, there seems to have been over-production. Latterly, a modified process, at a much higher pressure (1000 atmospheres), has been developed by the French engineer Claude.

Another process of making ammonia, now fully developed, involves the production first of calcium carbide,  $\text{CaC}_2$ , by heating a mixture of lime and anthracite coal in an electric furnace, then the conversion of this carbide, by direct absorption of nitrogen, into calcium cyanamide,  $\text{CaCN}_2$ . This latter interaction takes place at a moderate temperature and with

remarkable ease. Ammonia is obtained by subjecting the cyanamide to the action of steam.

Calcium carbide, it should be added, is made on a large scale as a source of the gas acetylene ( $\text{CaC}_2 + \text{OH}_2 = \text{C}_2\text{H}_2 + \text{CaO}$ ), now so much used as a lighting agent for road-traction purposes and even for domestic lighting away from towns; but chiefly, together with oxygen, in the form of the acetylene blowpipe, in cutting iron plates in the shipbuilding and other trades, in joining iron rails for the electric tram service, etc.

The production of nitrogen for the above-described processes and of oxygen has been greatly promoted by the researches on the liquefaction of gases carried out by Sir James Dewar, at the Royal Institution, Albemarle Street, London, the home of Davy and Faraday. The metallic vacuum vessels invented by this indefatigable student of low-temperature phenomena have made possible also the use of liquefied air, richer in oxygen than air, in various ways—in hospitals, for example; also, together with charcoal, as an explosive agent, in mining operations.

The astounding power properly prepared charcoal has, at liquid-air temperatures, of absorbing gases, another discovery made by Sir James Dewar, is proving of the greatest value in operations involving the separation and purification of gases. It is even contemplated that it may be possible to fill airships with the incombustible, rare gas, helium, prepared by taking advantage of this property of charcoal—the source of the helium being the natural gas associated with petroleum, in the American oil wells and in certain springs in Canada.

To return to the nitrogen compounds, the outstanding importance of ammonia and nitric acid will be understood when it is realized that cereal crops, including the sugar cane, cannot be grown without nitrogenous fertilizers. At Rothamsted, where wheat has been grown on the same land year after year under the same treatment since 1852, the average yield of grain has been only 12.9 bushels per acre on the permanently unmanured plot; whereas on the plot properly supplied with nitrogenous manures, it has been 31.6 bushels.

Now that both ammonia and nitric acid can be produced, by synthetic means, in any desired quantity, the world need have no anxiety as to the supply of artificial nitrogenous manures. Even if fuel should not be available to supply power, their manufacture will always be possible where water-power is to hand.

Large quantities of ammonium nitrate were made, during the war, for use in admixture with trinitrotoluene as a high explosive. Sulphate of ammonia and nitrate of soda are both only of partial value as fertilizing agents, as the one necessarily contains excess of acid and the other excess of alkali; these remain after the nitrogenous effect is exhausted; also the constant use of the sulphate involves a steady withdrawal of lime from the soil, ultimately rendering it acid, whilst the tendency of the alkali from the nitrate is to make the soil impervious to water. Of late years, there has been a gradual growth of opinion, therefore, in favour of ammonium nitrate, as this combines in itself the activity of an ammonium salt with that of a nitrate and, being used up entirely in the service of the plant, has not their harmful effect upon the soil. The objection to the use of the nitrate is its tendency to liquefy on exposure to a moist atmosphere and that it sets to a hard mass; moreover, it cannot be transported in bags.

The Germans have foreseen the value of urea,  $\text{CON}_2\text{H}_4$ , which is free from the disabilities associated with the nitrogenous fertilizers now in use. It is an entirely neutral substance and is undoubtedly an effective fertilizing agent under some conditions but it has yet to be shown that it could be used generally in place of the ammonium salts and nitrates. It can be made merely from ammonia and carbonic acid, so that if its manufacture can be put upon an economic footing and it prove to be suitable at least for most purposes, though it may not supersede ammonium salts, it may largely displace them from use.

Other methods of exploiting nitrogen are being studied which involve the direct absorption of the gas and its conversion to a cyanide; it is well within the bounds of probability that these may ultimately prove equal, if not superior, to the highly mechanical methods now coming into vogue: these latter, however, will

have the advantage that they can be carried out with the aid of water-power, unless the fixation methods should also be such as to necessitate the use of electric power.

More natural processes are also in sight. It is now customary, in most civilized countries, not only to waste the excreta of the urban populations but to do so at considerable cost. In the East, in China especially, human excreta are most carefully collected and used on the crops, they are actually a source of revenue to one or more towns. An activated sewage sludge process is coming to the fore which may be of service under European conditions: whether this will do more than conserve nitrogen is a question; if also the waste of phosphate can even be partially prevented, infinite service will be rendered. The chief limiting factor of agricultural production in the near future will clearly be the supply of phosphate and in the next degree of potash, we now know how to bring down nitrogen from the air but the supplies of phosphate and of potash are being drawn upon at exorbitant rates and must ere long be exhausted; no ways of withdrawing them from the vasty deep, which can be put in practice, are before us. It is found that at least the solid matter in sewage can be recovered in a valuable form by forcing air into the fresh liquid; when this operation has been repeated several times, first forcing in air, then allowing the suspended solid to subside, running off the liquid and adding fresh sewage, the sludge acquires a greatly enhanced bacterial activity and apparently even nitrogen-fixing organisms come into activity: eventually it may contain 6 to 7% of nitrogen and become equal to farmyard manure in value.

The amount of farmyard manure now available is insufficient, as the number of horses kept is so much less than formerly. Recent inquiry has shown that a complex series of changes is involved in the production of this manure from the straw and animal exuviae of which it is composed and that eventually it may contain a considerable amount of nitrogen beyond that originally present in the raw materials. Organisms are at work which destroy much of the carbonaceous matter but, in the course of the operation, they induce the fixation of a certain amount of atmospheric nitrogen, if supplied with the nitrogenous food they require for their own development. It is therefore conceivable that an economic process may be developed of manufacturing farmyard manure from waste carbonaceous materials with the aid of ammonia. The development of greatest importance in agriculture, however, to which we may look forward, is the direct enrichment of the soil with nitrogen, directly withdrawn from the atmosphere: either by means of organisms functioning in immediate association with leguminous crops; or by organisms within the soil, whose activity is promoted by the judicious use of green manures. No branch of scientific inquiry is of greater importance to mankind than studies to promote such ends.

The soap industry has undergone marked development of late years, owing to the increasing consumption of margarine as a substitute for butter. As the hard fats are required for the manufacture of this material, it has been necessary to make use of the natural fatty oils in soap-making; these differ from the hard fats in that they are glycerides not of saturated but of unsaturated fatty acids. To harden them, *i.e.* to convert them into glycerides like those contained in the ordinary solid fats, the heated oils are subjected to the action of hydrogen gas in presence of finely divided metallic nickel, which acts as a catalyst. The process is now carried out on a very large scale.

In the metal industry, the developments have been in matters of detail. Aluminium, nickel, tungsten and sodium have been brought greatly to the fore. One of the most notable achievements is the production of a rustless steel, an alloy of iron and chromium, which will bear sharpening when made into knives; apparently the special qualities of the steel are the outcome of a particular structure developed by heat treatment, though why the alloy should be rustless is not clear.

As illustrations of the manner in which the rarer inorganic materials are gradually being imported into industry, reference may be made to the use of vanadium oxide as an oxidizing catalyst, of titanium oxide as a white paint—on account of its high

refractive power; and of cesium alloyed with iron—in substitution for the old flint and steel in kindling fire.

Marked progress has been made in devising synthetic methods of manufacturing some of the simpler carbon compounds heretofore obtained only from natural products. Thus formic acid has been prepared, on a considerable scale, by combining carbonic oxide with caustic soda, under pressure—one of the earliest syntheses effected by the French chemist Berthelot.

Acetylene, another discovery of this chemist, has been converted into alcohol, on the large scale, by processes also due to his acumen, by passing acetylene, prepared from calcium carbide together with hydrogen over a suitable catalyst thus producing ethylene,  $C_2H_4 = C_2H_2 + H_2$ ; then absorbing the ethylene in sulphuric acid of suitable strength and distilling with water, to hydrolyze the sulphate that is formed  $C_2H_4 + H_2SO_4 = C_2H_5 \cdot HSO_4 | C_2H_5 \cdot HSO_4 + H_2O = C_2H_5 \cdot O + H_2SO_4$ . The process is said to have been an economic success, in Italy, where water-power is available. The process has also been carried out experimentally with coke-oven gases as a source of ethylene.

During the war, much acetic acid was made from alcohol by first converting this into aldehyde and hydrogen, by passing the vapour over heated copper; then oxidizing the aldehyde by means of air, in presence of a manganese salt. Acid so made is of better quality than that from crude calcium acetate. Acetic acid has also been produced by oxidizing aldehyde prepared directly from acetylene, through the agency of sulphuric acid acting in conjunction with mercuric and ferrous sulphates; oxygen distilled out from liquefied air has been used in the process. The cost of acid prepared in this way, in one of the chief German works, in 1910, is stated to have been £50 per ton. The importance of acetic acid is now far greater than it was, owing to the use that has been made of it in preparing varnishes or dopes for airplane cloth. The attempt is also being made to develop the manufacture of artificial silk from acetylcellulose.

The manufacture of explosives has involved various other developments. Prior to the war, the acetone used as a solvent, in making the propulsive cordite—a mixture of the trinitrates produced on supernitri-fying glycerol and cellulose—was obtained by the dry distillation of calcium acetate, this being made from the crude acid which is obtained, in carbonizing wood, together with wood spirit or methylic alcohol. When a shortage of the supply of acetate was imminent, two new methods of making acetone were developed—one involving the passage of acetic acid vapours over heated alumina ( $2CH_3 \cdot COOH = CH_3 \cdot CO \cdot CH_3 + CO_2 + OH_2$ ); the other the fermentation of glucose by a special organism giving rise to a mixture of acetone and normal butylic alcohol. Success was found to depend on the use of a pure organism and at first much difficulty was experienced in sterilizing the large bulks of liquid used: two of the organisms were not killed until the temperature was raised to 130°.

Acetone was originally used in making cordite, because it is a solvent of cellulose trinitrate. Another way of overcoming the difficulty, created by the shortage of the solvent, was found in the use of a less nitrated cellulose, soluble in a mixture of ether and alcohol. This departure involved the manufacture of ether not by a new method but on an unprecedented scale, without any difficulty. Another substance made on a scale which might previously have seemed inconceivable was hydrogen cyanide or prussic acid. Experience showed that any desired substance may be made on any desired scale, putting economic cost aside.

Hitherto, glycerol has always been obtained from natural fats, usually as a by-product of the manufacture of soap. It is a constant product of the fermentation of glucose by yeast in the brewing process, although only about 3% of the sugar used takes this form. Experiments carried out in America and Germany, during the war, showed that the proportion might be raised even to 20% by carrying on the fermentation in presence of an alkaline sulphite or carbonate. If needs were, therefore, glycerol might be manufactured from starchy materials.

A point of interest in connexion with explosives was the use during the war, for the first time, of Borneo petroleum as a source of much of the toluene required for the manufacture of trini-

tritoluene (TNT). Previously, toluene had been obtained only from coal tar. The presence of this and similar hydrocarbons in petroleum was first noticed by Hugo Müller and Warren De la Rue. The complete nitration of toluene to TNT is a matter of some difficulty. As proof of the value of scientific insight and the practice of a rigid scientific method in manufacturing industry, the fact may well be mentioned here that the most efficient British works for the production of this explosive, although only a small one, in point of quality of product and cost of production, was one established, at a very early date, by a Scotch professor and a young colleague versed in physical chemistry.

The explosive picric acid or trinitrophenol was also made on a large scale, not only from phenol extracted from coal tar but also from synthetic phenol, prepared by sulphating benzene and fusing the sulphate with caustic soda ( $C_6H_6 + H_2SO_4 = C_6H_5 \cdot SO_3H + OH_2$ ;  $Ph \cdot SO_3 \cdot Na + Na \cdot OH = Ph \cdot OH + SO_3 \cdot Na_2$ ). In England and France the old, barbaric, wasteful process of nitrating the phenol was unfortunately followed and the manufacture was never put on a scientific footing. A substantial amount was made, however, by a very superior process, involving the conversion of benzene,  $C_6H_6$ , first into chlorobenzene,  $C_6H_5Cl$ , then into dinitrochlorobenzene,  $C_6H_4(NO_2)_2Cl$ , next into dinitrophenol,  $C_6H_3(NO_2)_2 \cdot OH$ , finally into trinitrophenol,  $C_6H_2(NO_2)_3 \cdot OH$ . The operations are all carried out with extreme ease and except the first afford all but quantitative yields.

Many substances were made for the first time on a large scale during the war, and used as "poison gases" and to excite weeping; among the latter was chloropicrin, produced by "chlorinating" picric acid, in presence of soda. The one which became of most consequence, the so-called mustard gas, really a by-product easily volatilized liquid, was always manufactured by the Germans by a rather involved process devised by Victor Meyer, which was never brought into operation, in an effective manner, elsewhere than in Germany. Shortly before the Armistice was declared, however, a far simpler method was developed, in England, which involved merely chlorinating sulphur and then passing ethylene into the chloride:

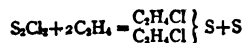

Very large quantities had been prepared for use in the field, just before the war came to an end. No difficulty was experienced in preparing any desired quantity of ethylene, by heating alcohol with phosphoric acid.

Two substances have acquired importance, the one as a detonator, the other as a primer in starting the ignition of the less sensitive TNT, lead azide,  $Pb(N_3)_2$ , and trinitrophenylmethylnitramine,  $C_6H_2(NO_2)_3 \cdot N \cdot (CH_2)_3 \cdot NO_2$ . The former has the advantage that it is stable under the high temperature conditions of the East, where mercuric fulminate, the detonator commonly used, cannot be kept long. Prior to the war, the acid HN<sub>3</sub>, from which the azide is made, was little more than a chemical curiosity and almost feared on account of its instability. The nitramine referred to was made preferably from methylaniline but chiefly from dimethylaniline, two substances much used in the dyestuff industry.

Attention has been directed very frequently, of late years, to the production of a substitute for indiarubber. Thus far the German manufacturers have not been able to control the final stage of the process, that by which the simple hydrocarbon used initially is converted into the rubber complex. The "polymerization" is effected only gradually and at a slow rate; in fact, the material is merely placed in hermetically sealed barrels and allowed to remain undisturbed, during six months, at about 32° C., the rubber being finally obtained as a white spongy mass which has to be bored out of the barrels. The minimum cost of production appears to have been about 18s. per pound. The Germans went so far, however, that they organized the manufacture on the scale of a possible output of 1,000 tons per month. The opinion that prevails is that the process cannot under any conditions be an economic success, until it can be controlled and much accelerated; it is dangerous to assume that this will

not be done. Moreover, the attack on the rubber trees by fungoid pests is becoming so serious and the conditions of growth are so special, if not unnatural, that the future of the "natural" industry cannot be regarded as established and secure: it may well suffer the fate of the coffee plantations in Ceylon. The direct vulcanization of rubber, it may be mentioned, is now effected, in a most ingenious manner, by subjecting the material to the action of sulphuretted hydrogen and sulphur dioxide gases, the necessary sulphur being produced *in situ* by their interaction.

In the great dyestuff industry, the developments have been mainly in the direction of improvements in the manufacture of the intermediate materials and in the use of by products as substantive agents; the tendency has been to aim at the production of dyestuffs of ever-increasing fastness, that is to say, able to withstand light, soaping and the bleaching agents so largely used in cleansing fabrics. To cite an instance of progress in the making of materials, phthalic acid is now produced by merely passing the vapour of naphthalene mixed with air over a heated catalyst—vanadium oxide—instead of by the uncertain and troublesome method of heating with sulphuric acid and mercury. The most notable advance in the manufacture of dyestuffs is the use particularly of the hydrocarbon anthracene, the parent of the madder dyestuffs, in the production of a series of pigments known as vat dyestuffs; one of the latest of these is a green, in many ways superior to the green dyestuffs hitherto known. Like indigo, these are reduced, in the dyer's vat, to a soluble state, by means of sodium hydrosulphite; when the cloth has been impregnated with the solution and it is exposed to the air, the reduced material becomes oxidized and the dyestuff is deposited within the fibre. The really serious rival of indigo, in the future, may well be one of these dyestuffs, indanthrene, which is a magnificent blue considerably superior to indigo in fastness. The contention that natural dyestuffs are superior to the artificial is now disproved in a multitude of cases.

In addition to indigo, a variety of *indigoid* dyestuffs, similar in constitution to indigotin, including derivatives of this latter compound, are now in use, differing from it in shade of colour. *Indigo*, the product of various species of *indigofera*, has never been made artificially: only its chief pigmentary constituent, *indigotin*, is manufactured. Synthetic indigotin is now largely used, especially in calico printing; it is of particular value in dyeing light, clear shades of blue. These cannot at present be secured with the aid of indigo, but the natural product is now known to be superior for heavy shades on wool (blue serge, etc.), owing to the presence of other dyestuff constituents, together with indigotin. Much has been done during the war to re-establish the indigo industry in India. If scientific findings be accepted, provided the commercial side of the problem be properly handled, indigo may well resume the place it had lost as a dyestuff, though it can never attain to exclusiveness.

One important development in this field is to be chronicled. In photographic chemistry, which has long been at a standstill, there has been a notable advance, particularly in the all but complete control secured over the colour sensitiveness of the photographic plate. When the necessity arose, the required staining materials were produced in English laboratories without any difficulty and a command of the problems of staining has been secured far beyond that of the Germans.

Astenishment has been created by the discovery that certain stains (notably pheno safranin) so diminish the sensitiveness of the gelatine-bromide emulsion to light, that if the most sensitive of plates be exposed, then placed during a brief period in a weak solution of the stain, development afterwards may be carried out in the weak light of an ordinary candle.

A great new field on the verge of development is that of the carbonization of coal at low temperatures, with the object of conserving the gaseous and oily products that are burnt wastefully when it is used directly as a fuel, as well as of obtaining a solid fuel, of higher efficiency than coal, which can be burnt without producing smoke. The long-discredited process of making illuminating gas for domestic use by merely distilling coal must soon be superseded by rational methods, especially

as the demand for gaseous fuel is increasing very rapidly. The change will involve the disappearance of gasworks (tar, so that the dyestuff industry will be forced to rely upon the high temperature coking ovens for its raw materials—or discover other sources of supply; the use of tar on roads will also be diminished. The development of a synthetic process to convert a mixture of carbonic oxide and hydrogen into methane may well prove to be of importance in this connexion. It is known that the conversion may be effected without special difficulty, using nickel as a catalyst; but the process has yet to be developed on an economic scale. The successful use of nickel as a catalyst, in purifying coal gas from sulphur (other than as sulphuretted hydrogen), may be referred to as another striking instance of industrial advance.

A wave of scientific method is pulsating throughout the world, which is everywhere influencing industrial development. There is an obvious desire to assimilate the procedure of the works with that of the scientific laboratory and particularly to develop the use of machinery in the former; but if empiricism be departing, progress is at very different rates, not only in different lands but in different industries, some being very slow to move. The chemist of the future, to carry the burdens of his day and succeed, will needs be both very widely trained and gifted with reflective power and insight: victory must fall to the scientific rather than to the strong or the swift.

*Progress in Organic Chemistry.*—It is necessary to bear what the expression "Organic Chemistry" should cover. As a philosophy, at the present time, chemistry is in a difficult position owing to the extent of the field, the over-subdivision of the subjects and the ever-growing tendency of workers to specialize, knowledge of facts having been unduly cultivated at the expense of breadth and precision of scientific outlook. Liebig remarks, in one of the earliest of his celebrated *Letters on Chemistry*, "The attaching too high a value to the mere facts is often a sign of a want of ideas. It is not fertility, but poverty of ideas which clothes itself with a mass of coverings of all sorts or wears old, battered, threadbare and ill-fitting garments." It is to be feared the criticism holds to-day.

The science of chemistry is conventionally divided into two main sections—the inorganic and the organic; but these are most unfortunately defined. Substances derived from animals or plants—formed it was thought under the influence of a vital force—were originally the subject matter of organic chemistry. When the discovery was made that such substances could be prepared by artificial means—first in 1828, when Wöhler synthesized urea—organic chemistry became the study of the compounds of carbon: though the systematic definition was a gain of precision, the chemist's outlook was narrowed and confined, as attention was withdrawn from the concurrent study of vital phenomena. A more unfortunate consequence of the rigid subdivision of the field is, that the two branches have been treated as separate disciplines; usually the carbon compounds have been regarded as the subject mainly of higher academic and professional study, so that those who have sought to acquire only an elementary understanding of chemistry have been denied the very knowledge likely to be of most importance to them.

The study of carbon compounds has been prosecuted with extraordinary diligence, during the past 50 years, by a large number of workers who have been attracted by the beauty of the problems the subject affords and the consistency of its methods. An astounding fabric of structure has been reared which is all but unknown, except to the few; and yet it is laid upon the simplest of foundations and its main features and lessons are easily grasped. No one can claim to be a chemist who is not seized with the spirit of this knowledge.

The study of structure has played little if any part in inorganic chemistry and until recently this branch attracted relatively few workers; it has further suffered, not only from neglect to apply the lessons to be derived from carbon compounds but owing to its own subdivisions—through the treatment of metals under metallurgy, as a separate subject. Of late years subdivision has been carried still further, by the creation of a physical section of very limited range, as something apart, the attempt has

even been made to treat "colloids" as a separate branch. To make chemistry of avail some change of attitude is desirable. The prime need of our time appears to be that we should recognize the essential unity of chemical science, in order that we may teach the fundamental principles and the syntactical issues as a single discipline. The characteristic of organic chemistry has been the attention paid to the determination of molecular structure and to that of function, both chemical and physical, as an outcome of structure; too little attention has been paid by the inorganic chemist to these issues. It is essential that the conception of structure and the methods followed in determining structure in the case of the simpler compounds of carbon should be brought before the student at an early stage.

Ceasing to draw the invidious distinction now made by classing carbon apart, mainly because this element has so numerous a progeny, we shall with advantage treat each of the great family groups of elements as a separate stock or tribe, but take into account the graded interrelationship of families and the effects of unions between their members.

No science can work alone. The chemist in future will be associated either with the physicist or with the biologist, if not with both. In conjunction with the former, he will extend his studies of structure and function into atomic regions: the quest is one that seems to need the mathematical habit of mind. He will cooperate with the latter by applying his knowledge of molecular structure and function to the explanation of the living mechanism and of its activities as functions of structure—even including those of mind: in this field the mathematical habit of mind seems to be almost out of place.

We may anticipate, wrote Liebig, more than 70 years ago, that from organic chemistry the laws of life—the science of physiology—will be developed. It is in this sense that we need to raise up a science of organic chemistry in future—the organic chemist must once more be the proclaimed student of vital phenomena, not merely of materials. The two outstanding exponents of the art thus defined have been Liebig himself and Pasteur, the one having rendered supreme service by his general precept, the other by demonstrating the essential interdependence of chemical and vital phenomena.

The great lesson we have thus far learnt is that the activity of nature is of a circumscribed character, far more so, in fact, than is that of the chemist in the laboratory. At some time choice has been made of particular types of material and definite lines on which alone action may proceed have been laid down. Nature has learnt to wear only a single glove: all living things are essentially composed of one-handed (asymmetric) materials. The controversy long waged over spontaneous generation must be regarded as futile, in face of this conclusion. Whether the lines of action in nature are innate in the primary materials used, time alone can show: the chemist is tempted to think that this may well be, as within his own field of operation he finds that the structural possibilities are most definite in character and relatively few in number. The underlying policy of nature would seem to be the repetition of units of a simple kind. Tennyson has summed up the situation in the line—

So careful of the type she seems,

and Pasteur, in the more definite comprehensive phrase, *La vie est dominée par des actions dissymétriques.*

Apparently the destinies of life are determined by the element carbon, which is distinguished from all others not merely by the multiplicity of its compounds but by their relative stability—a stability, however, which is accompanied by remarkable plasticity. If there be life elsewhere, it can scarcely be very different from ours—carbon seems to be the only possible nucleus element, the only one which can give rise to combinations imbued with the necessary stability and also sufficiently reactive.

Next to carbon, water is the factor of primary importance. The operations of dehydration and of hydration play the determining part in the constructive process; next to these come those of oxidation and reduction, which are but the separated activities of those of hydration or its reverse.

The level of energy is raised by oxidation, it is gradually lowered by successive "hydrations," as in the process of fermentation. Whilst the chemist is frequently forced to resort to high temperatures and high electromotive forces to produce his results, nature does most of her work at a low energy level. In only one operation is she helped by a transcendent, irresistible power—that of solar radiations of short wave length: but this is the primal step in life and the energy taken in at this stage must suffice in all subsequent acts, as even that derived from oxygen is to be thought of as stored up in the same operation; the separation of the oxygen from the natural system carbon dioxide plus water, now with the aid of chlorophyll but primarily through some simpler agency. Nothing is more wonderful than the silent, steady way in which the glucose, formed at the expense of the carbon dioxide present to the extent of only three ten-thousandths in the air surrounding the plant, is built up underground, in the dark and at atmospheric or a lower temperature, into starch—as in the potato tuber, for example. In no way can the chemist imitate the act. Selective and directive influences are clearly at work: we have reason to believe that these are to be found in an enzymic mechanism.

The observations made, of late years, on the formation of minute amounts of formaldehyde and even of glucose on exposure of solutions of carbonic acid to rays of short wave length, are of little if any assistance in enabling us to follow the natural process. A complete mechanism is provided in the chlorophyll system but what this includes we do not know. The suggestion has been made that there is a factor at present unknown, as assimilation (measured by the amount of oxygen liberated) is less active in leaves brought into light when only a few days old than in leaves equally greened several days older.

Of chlorophyll itself much is now known. So long ago as 1864/ the late Sir George Stokes came to the far-reaching conclusion that the chlorophyll of land plants is a mixture of four substances, two green and two yellow, which by proper treatment may each be obtained in a state of very approximate isolation. Most of the chemists who followed him succeeded only in isolating decomposition products, but Willstätter, who took up the inquiry in 1906, has shown that the inference of the great physicist was correct. He finds that all green plants contain

Chlorophyll a, blue-black, in solution green-blue	$C_{41}H_{70}N_4Mg$
Chlorophyll b, green-black, in solution pine green	$C_{40}H_{68}O_4N_4Mg$
Carotene, orange-red crystals	$C_{40}H_{56}$
Xanthophyll, yellow crystals	$C_{42}H_{64}O_4$

The brown algae contain a third yellow constituent, fucoxanthin  $C_{52}H_{80}O_6$  though a very small proportion of b chlorophyll. The pigment of the ripe tomato is an isomeric of carotene, lycopin. Egg-yellow is coloured by an isomeric of xanthophyll, lutein. Willstätter finds that there is less variation in the amount of chlorophyll in plants of different species than in leaves of any one plant of different age or subject to different conditions of exposure. The amount varies from 0.6% to 1.2% of the dry weight and is usually about 0.8%, 0.6% being the a and 0.2% the b component. There is no noticeable variation during the day. The yellow pigment varies in amount between 0.1 and 0.2%, 0.07 to 0.12 being xanthophyll and 0.03 to 0.08 carotene. Expressed in molecular proportions, the a component is present in the ratio of 3 to that of 1 of the b variety; the yellow pigments are present in the reversed ratio of 1 of carotene to 1.5-2 of the oxidized compound xanthophyll but the variation being greater between exposed and shaded leaves than in the chlorophylls. The ratio (a+b) of the chlorophylls to the yellow pigments (c+x) as a mean of all the determinations made is 3.56, the value for exposed leaves being 3.07 and for shaded 4.68. Only further inquiry can show whether the coloured components of the chloroplasts are all genetically connected and which have functional significance.

It is a striking fact that chlorophyll has the closest affinity with haemoglobin, the red colouring matter of blood, the central system of each being apparently a complex of four substituted pyrrole rings; the two compounds are so closely related, in fact, that they may be reduced to the same compound, thioporphin.



phyrin  $C_{24}H_{26}N_4$ , when decarboxylated; in the one, an atom of the metal iron is included, in the other an atom of the metal magnesium; these metals, however, are not in the state in which they occur in their ordinary salts. When completely degraded, both compounds give rise to a mixture of the three simple pyrroles:—

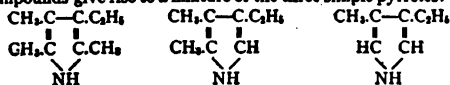

The character and complexity of their structure will be apparent on consideration of the following formula assigned provisionally by Willstätter to aethiopyrphyrin, the derivative common to both compounds:—

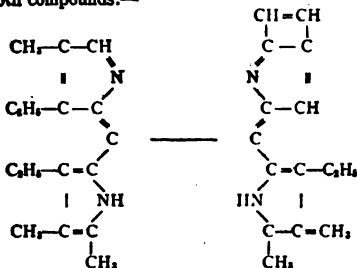

Aethiopyrphyrin is convertible into a magnesium derivative, aethiopyllin,  $C_{24}H_{24}N_4Mg$ , which is probably formed from it by the displacement of the two atoms of hydrogen in the two NH groups shown in the above formula. Perhaps the iron occupies a like position in haemoglobin.

In haemoglobin, the coloured system is loosely coupled with a peculiar protein, globin, present to the extent of 94% in the complex molecule; in the less weighty molecule of chlorophyll, the coloured system is coupled with the wax alcohol, phytol,  $C_{26}H_{52}OH$ . Both appear to be derivatives of dicarboxylic acids: the disposition of the  $CO_2H$  groups in haemoglobin is not clear but probably they are in connexion with the globin; in chlorophyll, one is neutralized by methyl, the other by the phytol radicle. Chlorophyll, unlike haemoglobin, is associated, in most plants, with an enzyme, by which it is hydrolyzed into phytol and the carboxylic acid, chlorophyllid; not only may the action be reversed (to the extent of 65%) but if hydrolysis be affected, in presence of either methylic or ethylic alcohol, methyl or ethyl takes the place of the phytol radicle. The behaviour of the enzyme is precisely that of the enzyme lipase towards fats and towards mixtures of fatty acids and alcohols. Alkalies convert chlorophyll into the corresponding dicarboxylic acid, from which the magnesium is easily displaced by hydrogen by means of acid:—

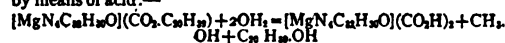

The special activities of haemoglobin and chlorophyll are in no way accounted for, at present, by what is known of their structure: colour apparently is of no consequence in the former but it is held to be the prime factor in the functional activity of the latter. Presumably both act as particulate agents, in virtue of their high molecular weights, not in solution. The oxygen-holding power of haemoglobin is commonly ascribed to the iron and it is supposed that the gas enters actually into combination with the molecule; whilst the former is mere matter of opinion, the latter view is supported by evidence, *i.e.* by the fact that the formation of oxyhaemoglobin involves the addition of a definite proportion of oxygen. Chlorophyll is not known to behave in a similar way towards carbon dioxide. Willstätter has shown, however, that when the gas is passed into water in which chlorophyll is suspended, this is converted into phaephyllin, the magnesium being wholly displaced, as indicated by the equation

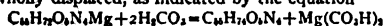

The action may be stopped halfway, when apparently the mag-

nesium is only half dissected out of the molecule and is retained, perhaps, together with an added molecule of carbon dioxide, thus

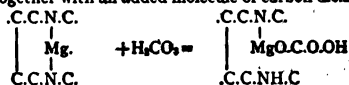

On the assumption that such a mechanism is operative, it is possible to understand how the carbonic acid is brought into the circuit of change and under the direct influence of the pigment. The acid would be at a maximum concentration at the surface of the particles. The acid radicle  $MgO.CO.OH$  would necessarily be a terminal point from which electrolysis could proceed: so that if, on exposure to light, a photoelectric wave were propagated from this point, throughout a circuit in which acid-water was included, the water would be electrolyzed and the carbonic radicle might well be subjected to the attack of hydrogen ions and reduced, ultimately to formaldehydrol, chlorophyll being regenerated in the process. The correlative product of electrolysis would be hydrogen peroxide ( $2OH_2 = 2H + H_2O_2$ ).

The evolution of oxygen from the plant in such case would be the consequence of the decomposition of hydrogen peroxide, perhaps by a "catalase." That evolution of oxygen and reduction of carbonic acid are coincident phenomena can scarcely be doubted, as the gas is only produced in presence of the acid and the volume liberated is proportional to that of the carbon dioxide absorbed. It is conceivable that one of the chlorophyll components may play the part of a catalyst, even that the more oxidised may act as platinum black, in the manner Willstätter has suggested: but these are all matters of mere surmise at present. Maybe a more complex circuit is formed than that postulated, one in which perhaps a depolarizer is included; these are all points, however, which must be left for further inquiry.

It is conceivable that the function of iron in haemoglobin is similar to that pictured of magnesium in chlorophyll: that the iron atom becomes partially separated from the molecule, owing to the formation of a perhydryl radicle, similar to that postulated by Willstätter as the active agent in platinum black and as operative in ferrous sulphate perhydryl.

Whatever the process it is to be supposed that formaldehydrol [ $CH_2(OH)_2$ ] is the initial product of the assimilation of atmospheric carbon dioxide by the plant; no other explanation that will meet the facts has been advanced. No laboratory proof that carbonic acid can be reduced and "sugar" produced in minute amount, however, is of the least value in enabling us to understand the origin of life. We have to account not for the formation of sugar but of one of the several not to say many possible isomeric forms as a fundamental structural unit: to explain why of the two glucoses of like structure but enantiomeric—*i.e.* related to one another as an object is to its image or one hand to the other—both of which are produced simultaneously in equal amounts when the synthesis is effected under artificial conditions, *only the one is formed within the plant*. What act or accident determined such selection, it is impossible to say; whatever happened, the future course of natural action was limited thereby to one type of symmetric material—to the one-handed forms, in genetic relationship with that first selected. Innate peculiarities, only dimly perceptible at present, are also operative in restricting the number of the primary constructive units. It is a remarkable fact that formaldehydrol gives rise to a hexose almost directly, yet it is to be supposed that condensation takes place gradually. In presence of weak alkali it rapidly gives rise to both fructose and sorbose; other products are formed which have not yet been identified; no intermediate products have been reported, such as are formed forthwith undergo further change. The product of the interaction of two molecules would be glycolic aldehydrol:—

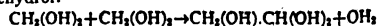

This is a known substance: it has been shown to give rise to the same hexose as formaldehydrol under the influence of alkali. If three molecules of formaldehydrol were to interact directly or glycolic aldehydrol were to be attacked by formaldehydrol, two

trioses might be formed, glyceraldehyde and glycero-ketose; thus  

$$\begin{matrix} \text{CH}_2(\text{OH}) + \text{CH}_2(\text{OH})_2 & \rightarrow & \text{CH}_2(\text{OH}).\text{CH}(\text{OH}).\text{CH}(\text{OH}) + \text{OH}_2 \\ \text{CH}(\text{OH})_2 & & \text{CH}_2(\text{OH}).\text{C}(\text{OH})_2.\text{CH}_2\text{OH} + \text{OH}_2 \end{matrix}$$

Both compounds are known: they are easily obtained by oxidising glycerol,  $\text{CH}_2(\text{OH}).\text{CH}(\text{OH}).\text{CH}_2(\text{OH})$ . In solution, in presence of a trace of alkali, the one is rapidly converted into the other: consequently a solution made from either is a mixture of the two in equilibrium; but as the molecule of glyceraldehyde is asymmetric, this compound is present in two forms of opposite optical activity:—

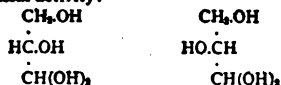

Fructose and sorbose, the two ketohexoses obtained in laboratory operations, in the manner described, whether from formaldehyd, glycollic aldehyd or the complex triose mixture referred to, are constituted as represented by the formulae

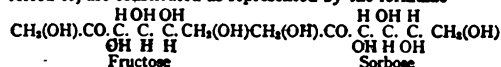

The formation of the two isomerides is accounted for, and is indeed to be expected, on the assumption that the condensation is effected equally between glycero-ketose and each of the two oppositely active forms of glyceraldehyde, which would necessarily be present in equal proportions: for the same reason each isomer would be produced in its two forms of opposite optical activity. It is a remarkable fact, therefore, that whereas fructose is of universal occurrence in plants, sorbose is very rarely met with: this is one of the many indications that in plants the course of synthesis is narrowly directed.

It is conceivable that if six molecules of formaldehyd were brought into position side by side and condensation took place throughout the series, all the possible hexoses might arise, through the fortuitous arrangement of the molecules in the many possible ways. The force of the argument is lessened by the probability that affinities would come into play which would determine arrangements in particular ways; probably the number would be less than is conceivable but yet greater than it actually happens to be. This conclusion, however, but serves to confirm the argument used above as to the actual course of the process: that it is essentially a live stage process. Perhaps in nature, at least, pentoses may be formed directly, but to judge from laboratory experience it is equally if not more probable that the hexoses are the only primary products and that other simple carbohydrates are derived from them: in other words that the hexoses are both primary products and reserve materials.

The preferential formation and the superior stability of the *ketose* system is to be referred to certain peculiarities of structure which are probably innate in the component elements. It has long been held that the aldehydic sugars are not true aldehydes and the ketonic not true ketones; they are too inert in behaviour to pass as such. The true aldehydols and kethydrols, if present at all, enjoy but a fleeting existence in solution; their place is taken by closed chain derivation. Thus:—

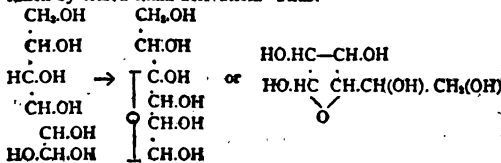

As the "terminal" group concerned in this change carries two hydroxyls either of which may be active, and the group becomes asymmetric in the course of the change—a new asymmetric system being created in the molecules,—it is to be foreseen that two isomeric compounds will arise in this way. As a matter of fact "glucose" is known to be an equilibrated mixture of an  $\alpha$  and  $\beta$  form, differing in optical activity and other ways, which

can be separated. If either be redissolved in ordinary water it soon passes over into the other until equilibrium is again reached. If hydrogen chloride be added to a solution of glucose in methyl alcohol, after a time two methyl-glucosides can be separated, an  $\alpha$  and a  $\beta$  form:—

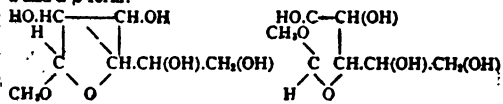

These are neutral, very stable compounds as compared with the parent glucoses. They are the prototypes of a large class of glucosides met with in plants and may be hydrolysed by enzymes which attack these latter. Hence it is possible to classify glucosides generally, in so far as they can be hydrolysed by enzymes which hydrolyse either a  $\alpha$  or  $\beta$  methylglucoside and can thus be correlated with either the  $\alpha$  or the  $\beta$  form of glucose. The enzyme maltase or  $\alpha$ -glucase, present in yeasts, is used in characterising  $\alpha$ -glucosides, the  $\beta$ -glucase in almond emulsin in characterising  $\beta$ -glucosides.

All sugars of the aldose and ketose types behave as described. The fructose sugars exist as condensed stable systems similar to that of glucose and, therefore, should persist, if formed when formaldehyd undergoes change and is converted ultimately into hexose sugars. Their non-production gives further weight to the argument that these latter are formed from the trioses.

Recently a third or  $\gamma$  form of methylglucoside has been found in the mixture obtained by the interaction of glucose and methyl alcohol. This new glucoside is very different from the  $\alpha$  and  $\beta$  forms; it is easily hydrolysed and easily oxidized by permanganate and very active in other ways. Probably it is a condensed system of the ethylenic oxide type:—

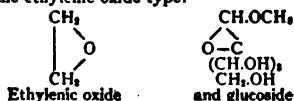

The discovery is of primary importance, as it has led to the discovery of a similar form of fructoside and has given the clue to the nature of cane sugar, long remarkable on account of the extreme ease with which, in comparison with other sugars, it is hydrolysed by acids and by the special enzyme invertase. The formula suggested for cane sugar is:—

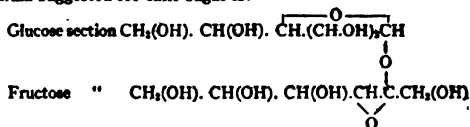

The difficulty in accepting this interpretation is that sugar is shown as either an  $\alpha$  or a  $\beta$ -glucoside and that it is hydrolysed only by a specific enzyme, not by either a  $\alpha$  or  $\beta$ -glucose. There can be little doubt that the fructose element is present in the  $\gamma$  form; if the glucose were also in the  $\gamma$  form the peculiar behaviour of cane sugar towards acids would be even better explained.

Although, in the laboratory, the sugars obtained from formaldehyd are the two ketoses, fructose and sorbose, in the plant glucose plays the preponderating part to a remarkable extent. Only three of the sixteen possible hexaldoses and two ketoses, glucose, mannose, galactose, fructose and sorbose, are met with as such or in combination in plants. Three of these are reversibly interrelated—glucose, mannose and fructose. If a solution of any one of the three be made alkaline and kept, gradually the other two make their appearance. A natural process is at work which seems to assure even the rapid passage of any one of the three into the others. It has been shown that, during fermentation with the aid of the juice expressed from yeast, an enzyme—phosphatase—is active, which, in presence of phosphate gives rise to a diphosphoric glucoside,  $\text{C}_6\text{H}_{12}\text{O}_6(\text{PO}_4)_2$ , the result is the same whether mannose, glucose or fructose be taken, but when

(this glucophosphate is hydrolysed only fructose is recovered. It is noteworthy that phosphoric acid has a determining influence on the plant, especially during the ripening period: it may well be one of its functions to promote the interconversion of carbohydrates in the manner indicated; if it can convert glucose into fructose it should be able to produce the contrary change, and so supply the material for producing either starch or inulin.

The actual change in an alkaline solution is pictured as involving the production, by dehydration of an unsaturated "enolic" compound common to the three hexoses and the conversion of this by dehydration, only in part into the original form and in part into the other two. The process is one apparently which plays a preponderating part in the course of vital changes. The alteration is only in the first and second carbon systems of the sugar; the manner in which it takes place is simple, thus:—

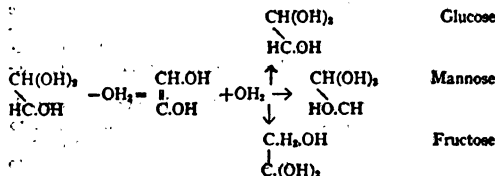

It has been pointed out that, in the laboratory, sorbose is formed together with fructose, when formaldehydrol is condensed, and that it is of rare occurrence in nature: if changed in solution as fructose is changed it would be converted into the sugars idose and gulose, but neither of these is met with. This fact and the rarity of sorbose is further proof that the vital synthetic process is narrowly controlled.

It remains to account for the production of galactose, which is very widely distributed and probably always present in plants, in small amount (as raffinose); this hexose is characteristic of mammalian milk, being coupled with glucose in milk sugar. Galactose is closely related to glucose: to account for the conversion of one into the other, it is necessary merely to assume that the glucose is resolved, by hydrolysis, into two molecules of glyceraldehyde, one of which is then changed in sign by the reversal of the position of the median OH group—a change known to occur in solution; if the two molecules of opposite activity were then re-associated through the agency of a directing mechanism the change might well be complete.

Two pentoses are commonly met with in plants but only in combination, the one *D*-xylose, corresponding to glucose, the other, *L*-arabinose, to galactose; a third, *D*-ribose, is also found, which is the only pentose normally present in animal tissues, in both cases as a characteristic constituent of the nucleic acids. Arabinose and xylose are important components respectively of the gums and of straw and wood; at present, there is no clue to the manner in which they are formed from hexoses in the plant, if indeed they are so formed: it is not improbable that an oxidation process may be at work, by which the  $\text{CH}_2\text{OH}$  group is removed from the hexose molecule whilst it is held in combination at the aldose end.

The higher carbohydrates are made up of hexose and fructose units in ways which we are only beginning to know: in fact, starch, cellulose and inulin are the only three of whose complete anatomy we have learnt anything, and the information does not carry us far. The labour involved in such work is immense, and methods of dissection are few. The most informative is that introduced by Purdie and developed by Irvine and his school, involving the methylation of the carbohydrate, the resolution of the complex into the constituent hexose fragments and the determination of the position taken up by methyl radicals in these: whence it is possible to infer, with more or less certainty, the manner in which the fragments were linked.

Whilst the primary unit of starch is glucose, into which it is resolved when completely hydrolysed, the chief secondary unit in the dextrane maltose, which is obtained as main product when starch is hydrolysed by the enzyme diastase; whether the sub-

stantary more complex product, dextrin, is also composed of maltose units is uncertain. Maltose is formed by linking two molecules of glucose in direct apposition.

The primary unit of cellulose is also glucose; the secondary unit, however, is a dioxose isomeric with maltose, cellose, differing from the former in that the two glucose bricks are laid, as it were, the one advanced a sixth of its length beyond the other. Moreover, the one is an  $\alpha$ -glucoside hydrolysed by maltase; the other apparently is a  $\beta$ -glucoside, as it is hydrolysed by emulsin. A third diglucose is known in gentiobiose, which is obtained, together with cane sugar, when the trihexoside gentianose from gentian root is hydrolysed by invertase; it is not only hydrolysed by emulsin but has been reproduced from glucose by the action of this enzyme; it is therefore undoubtedly a  $\beta$ -glucoside, and probably the  $\beta$ -glucoside alternative to the  $\alpha$ -glucoside, maltose.

The formula of the three sugars may be written as follows:—

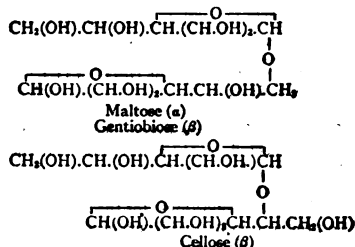

Trehalose, a gluco-dihexoside widely distributed in fungi, appears to be the representative of the third type, but its structure is not yet ascertained. As it has no "aldehydic" properties, such as are shown by the three sugars previously considered. It is supposed that the two glucose components may be conjoined as shown by the formula:—

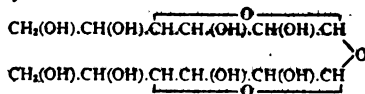

It is to be expected that such a compound would be hydrolysed either by maltase or by emulsin; such is not the case but it is resolved by a special enzyme present in fungi which appears to be peculiar to the sugar. The examples given may suffice to illustrate the manner in which hexose units may be linked together.

Inulin, the reserve material of the artichoke and dahlia tuber, is entirely composed, apparently, of fructose units in the  $\gamma$ -form. When acetylated it gives rise to a well-defined crystalline triacetate, which is clearly a simple derivative of the parent substance as inulin may be reproduced from it by careful hydrolysis. The determination of the molecular weight of this compound shows that it contains nine fructose units—a peculiar number.

In some plants, the monocotyledons especially, the place of starch is taken by cane sugar, little if any starch being formed; even in those in which starch is produced in considerable amount cane sugar is always present in the leaves, and it has been argued that cane sugar rather than starch may well be the primary product of assimilation. It is difficult at present to offer any rational explanation of the formation of cane sugar; the wish would be to regard it as traceable to enzyme activity.

All attempts hitherto made to synthesize cane sugar have been failures; it is completely hydrolysed by invertase. Either the point of equilibrium is so near to that of complete hydrolysis that it escapes detection, or the immediate products at once undergo change in solution and cease to be susceptible to the active influence of the enzyme: the fact that fructose is present in the  $\gamma$ -form in cane sugar and that this form does not persist in solution, either in fructose or dextrose, may not be without bearing on the problem. It is a matter of interest that cane sugar is usually present in leaves in considerable amount in the cell sap and together with invertase, but in some way separated from it:

maybe means are provided by which the sugar can escape from the influence of the enzyme immediately it is produced. In roots such as that of the sugar beet, in which cane sugar is merely stored up as a reserve material, no enzyme is present.

The close association, in the leaves of many plants, of starch with chlorophyll, in the chloroplasts, has led to the view that it may be an all but direct product of synthetic activity and not formed from glucose. It is indeed conceivable that a directive (enzymic) mechanism may exist which can induce both the production of glucose from formaldehyde and the simultaneous assemblage and union of the glucose units into starch.

The enzymes are agents comparable with the acids in their hydrolytic activity, but selective and directive. Unlike the acids they are catalysts—particulate agents. The effective area of the enzyme, however, must be some small section of the molecular surface and the only rational interpretation of the special activity of the enzyme would seem to be that this active area is composed of material compatible with that which the enzyme specifically attacks—that indeed it is this material, though conjoined perhaps with an acid radical, which acts as the actual "tool" in hydrolysis. Starch may be regarded as a pavement or simple mosaic built up of many separate glucose-residues regularly arranged in a definite pattern, and layer after-layer is laid in this fashion. The enzyme as a template formed of a single layer thus composed, maybe as the starch layer increases in thickness there is a coincident up-growth at its margin of the protein constituent of the enzyme complex. Given such a mechanism, it is conceivable that starch might be almost directly produced: some explanation is required to account for the preponderance of glucose in the plant. The conception is one, moreover, which may be used to explain the action of enzymes in other cases.

With reference to the conditions under which enzymes (and acids) may act reversibly, it is to be noted that the manner in which action takes place, both rate and direction, is determined by the conditions of concentration. As hydrolysis proceeds water is used up, if the reverse action take place, water is produced. Usually a point of equilibrium is reached, when no further change seems to be taking place. This is true even of the hydrolysis of cane sugar by acid as the concentration of the solution is raised and the opportunity for change is increased, the rate of change only rises up to a certain point, beyond which any further increase in concentration only serves to diminish the rate of the process. As the solution becomes more concentrated—in the case of cane sugar, particularly through the increase of the number of molecules in solution—it becomes itself more attractive of water and hydrolysis is less promoted. The extent to which synthesis is effected is entirely a question of balance of affinity—of desire for water. This point is one of extreme importance in connexion with vital phenomena. In plants, during the day time, synthetic actions prevail, as the tendency is constantly towards the concentration of the solutions in the leaf cells, when the influence of light is withdrawn water is attracted into the concentrated solutions and reversals set in, producing to an increased extent simpler molecules, which can wander out into the general circulation and be used elsewhere.

Thus far enzymes have been spoken of as influencing the hydrolysis and formation only of compounds consisting of sugar units—these are conveniently classed as *Hologlucosides*. Many sugar derivatives are known which are to be classed as *Heteroglucosides*, being of more diverse origin: the methylglucosides may be taken as typical of this class, especially  $\beta$ -methylglucoside, as most of these are more or less readily hydrolysed by the constituent of the mixture of enzymes in almond-emulsion to which  $\beta$ -methylglucoside responds. Curiously enough, the few known natural  $\alpha$ -glucosides are all hologlucosides, the known  $\alpha$ -heteroglucosides are all laboratory products.

The heteroglucosides are extraordinarily varied in composition. Little is known as to their precise function. Often they serve to give stability to a substance which could not well exist uncombined; or they mask one that would interfere if free, or they have the advantage of being far less soluble than the parent compounds. They form most of the colouring matters of flowers.

The most interesting member of the class perhaps is that first studied, amygdalin, present in considerable quantity in the fruit of the bitter almond and also in the fruit of most of the Rosaceae. It is resolved by emulsin—which is equally well obtained either from the sweet or the bitter almond—into two molecules of glucose, one of benzoic aldehyde and one of hydrogen cyanide:



The two latter are present in direct association, as in the cyanhydrol,  $C_6H_5CH(OH)CN$  in its dextro-rotatory form, the isomeric laboratory form being present in sambunigrin, from elder leaves—which, however, contains only one glucose residue. By the action of one of the enzymes in emulsin, amygdalase, amygdalin is resolved into glucose and prunasin, the isomerid of sambunigrin, this heteroglucoside occurs naturally in the leaf of the almond and of the common cherry laurel—in fact, in the leaves of all Rosaceae whose fruits contain amygdalin. Laurel leaves particularly are rich in an enzyme, prunase, which hydrolyses prunasin, this is present together with amygdalase in all fruits containing amygdalin. The resolution of amygdalin therefore, involves, it will be seen, the action of two enzymes in succession. What appears to be the amygdalase is present in some yeasts, together with maltase. The advantage to the plant is that the leaf contains the more soluble glucoside, that in the fruit being but slightly soluble; the presence of glucose and fructose in the leaf and stem but of starch in the tuber of the potato is a parallel case. How the two glucose residues are united is not determined the probability is that amygdalin is derived from gentiobiose. Prunase apparently is the  $\beta$ -glucase in emulsin which acts on the  $\beta$ -methylglucoside and the  $\beta$ -heteroglucosides generally to explain its indifference towards amygdalin and the varying degree of activity which it displays towards different  $\beta$ -glucosides, it is necessary to assume that the group associated with glucose influences the fit of the enzyme. If the enzymes be, as suggested, but replicas, in part, of the hydrolytes they effect, in each particular class, the glucoside characteristic of the class may well be contained in the enzyme: thus prunase from the Rosaceae is conceivably a prunasin derivative, whilst the  $\beta$ -glucase of the Linaceae may be a derivative of the cyanhydrol of acetone,  $C(CH_3)_2(OH)CN$ , consequently although both enzymes affect prunase they do not act with equal readiness, the addition of a second molecule of glucose to prunase, although it happens in the  $\beta$ -position, may spoil the fit of prunase, entirely. The problem is one of extraordinary interest and importance.

Glucose and its congeners are of special value in the plant, as constructive materials, on account of their peculiar plasticity under the numerous enzymic and other influences simultaneously brought into action in nature. These are especially manifest in the phenomena of fermentation. In recent years the controversy which has long been waged over the fermentation process, as effected by yeast and other organisms, has been settled against the *viastasis*, as it is proved that it can be carried out *a part from the living cell*, in its entirety, by means of the juice expressed from yeast, and even in presence of substances, such as acetone and toluene, fatal to the life of the cell. The course of change is by no means ascertained: as yet only the main outlines are marked out, but these are of such significance that it is clear that a most delicate balance of forces comes into play.

When the formulae are contrasted it is obvious that the ultimate conversion of glucose into carbon dioxide and alcohol must involve much rearrangement within the molecule. Oxygen must be removed from some of the carbon atoms and its place taken by hydrogen, the reverse operation has to be effected at others. That such changes can be induced by mere contact with acids or alkalis is well known: thus lactic acid,  $CH_3CH(OH)CO_2H$ , is easily formed by digesting glucose with alkali, reduction is carried still further in the production of lavalnic acid,  $CH_3CO-CH_2CH_2CO_2H$ , by boiling either fructose or glucose with an acid, fructose being the far more easily-attacked. This latter fact is perhaps not without significance.

A variety of factors come into play when fermentation is induced by yeast juice. Phosphate plays a part of fundamental

importance. When a suitable quantity of a soluble phosphate—best in the form of a solution of disodium phosphate saturated with carbon dioxide—is added to a slowly fermenting mixture of the juice with glucose, a rapid rise is observed in the rate of fermentation, as measured by the amount of carbon dioxide evolved. As change proceeds, the amount of free phosphate in solution diminishes up to the point at which the rate of change begins to diminish, the diminution has been traced to the formation of a phosphoric glucoside. Apparently, action takes place as expressed in the equation:



that is to say, while one molecule of sugar is fermented a second is fixed as phosphate. Apparently, however, all the sugar passes through the phosphate stage on its way to fermentation, as this slackens and finally ceases the amount of free phosphate in solution steadily rises, the action being reversed the while:—

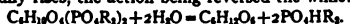

The formation and destruction of the phosphate are changes due to the action of an enzyme, hexosephosphatase.

The point of importance to be noted is, that whatever sugar be fermented—glucose, mannose or fructose—the hydrolytic product is fructose, one function, at least, of the hexosephosphatase would seem to be the presentation of the sugar to the resolving mechanism in the form most sensitive to rearrangement.

The resolving mechanism has several components. It contains one or more enzymes easily destroyed by heat, together with a so-called co-enzyme which survives when the liquid is boiled. These may be separated by mere filtration, under pressure, through a film of gelatin supported in a Chamberland filter-candle, neither residue nor filtrate alone will condition fermentation, but when they are reunited a mixture is obtained which is almost as active as the original fluid. Little, if any, light has been thrown on the nature of the resistant constituent, the most suggestive observation made is that it disappears from boiled yeast juice when this is digested with castor-oil lipase, an enzyme which hydrolyses fats and similar substances.

As to the course of change at some stage apparently the hexose molecule is resolved into two "halves," but whether before or after rearrangement is uncertain. There is, however, reason to suppose that the production of alcohol involves the prior production of aldehyde and the ultimate reduction of this latter. The formation of aldehyde is attributed to that of pyruvic acid,  $CH_3CO.CO_2H$ , which is resolved into carbonic acid and aldehyde by the action of *carboxylase*, an enzyme normally present in yeast:



Not only has this acid been obtained as a product of fermentation, but when fermentation is effected in presence of an excess of alkaline sulphite an amount of aldehyde is produced approaching that to be expected on these assumptions, if one half the molecule were so affected, at the same time, glycerol is produced in almost corresponding amount.

It seems probable, therefore, that in the ordinary fermentation process the hexose is normally resolved into a mixture of glyceraldehyde and glyceroketose, which became rearranged into pyruvic aldehyde, by enolisation and rehydration. The oxidation of these two molecules of aldehyde to pyruvic acid might then conceivably be the consequence of the reduction of two molecules of ordinary aldehyde to alcohol—the reduction of these must in some way be accounted for, if acetaldehyde be an intermediate product of fermentation. As a matter of fact, the function of an ordinary hydrolytic enzyme is nearly of this order, involving as it does either the separate presentation of the H and OH of water at two contiguous regions in a molecule or their withdrawal from two contiguous molecules, according as its action is either hydrolytic or synthetic. A directed interaction of the character contemplated is therefore not improbable. Not only is yeast known to contain the enzyme *carboxylase* which fits pyruvic acid but also another enzyme, *glyoxalase*, by which pyruvic aldehyde is converted into lactic acid, an operation involving (1) hydration, (2) enolisation, (3) reversed rehydration, starting from the



That the yeast complex may do all the things suggested is, therefore, by no means improbable. Glyoxalase, it may be added, occurs in various animal tissues, and the lactic acid formed as the result of muscular action may well be produced under its directive action. A striking observation made with yeast juice is that the action stops on adding hydrogen cyanide but recommences when this is removed. Yeast ceases to decompose hydrogen peroxide when the cyanide is added. Maybe, in both cases either an oxidase or a peroxidase is held in check which is effective in the pyruvic change.

A discovery of great significance, as throwing light on the reductive stage, is that recently made by Gowland Hopkins, of a minute constituent of yeast juice, liver substance and muscular tissue, glutathione, a neutral derivative (dipeptide) formed by the condensation of the two amino-acids, cysteine and glutamic acid. It is a powerful reducing agent and acts as a carrier of hydrogen, cysteine is a sulphur derivative of alanine and is readily converted into cystin, by oxidising agents, moreover, the change is reversible.

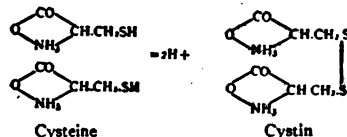

Glutathione apparently is but cysteine weighted by glutamic acid, and its activity is doubtless the consequence of a similar change. Possibly the hitherto unidentified co-enzyme of yeast juice may prove to be this substance.

*General Synthetic Activity*—That the plant exercises its synthetic activity with the aid merely of the simple cleavage products derived from carbohydrate material, by processes similar to those involved in alcoholic fermentation, is clear. The adjuncts are merely atmospheric oxygen and various materials obtained from the soil—especially ammonia phosphoric acid, magnesium and silicon; these are all of structural significance; in addition, iron and manganese, calcium and potassium, appear also to be indispensable, but are mainly, if not entirely, of value as functional agents. Although it is established that potassium is essential to the formation of starch, if not of other carbohydrates, no clue has yet been found to the office it exercises. Sodium, being there, is taken into the plant, whether it be in any way necessary, as it is to the animal, we do not know.

Whilst many compounds are undoubtedly formed under enzymic influences, others are products of the direct spontaneous interaction of materials which happen to meet. The precise manner in which even the simple benzene derivatives met with in plants are formed is not yet clear. That even substances so complex as the opium and other alkaloids may be formed, without difficulty, is shown by R. Robinson's remarkable observation that tropinone, a compound closely related to one group of these alkaloids, is produced when the aldehyde of succinic acid, methylamine and acetone, or still better its dicarboxylic acid, are merely brought together, in aqueous solution, at the ordinary temperature:—

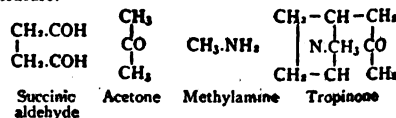

*Plant Colours*.—Considerable diversity in character may be the outcome of small differences in chemical structure: this is well illustrated in the colouring matters of flowers which, it is well known, vary over a considerable range. The yellows, however, appear all to be derivatives of a simple compound, not itself coloured, flavone, which occurs as a mealy deposit on the leaves and flower stalks of a large number of *Primulaceae*. It is resolved,

by hydrolysis, into the two simple compounds, salicylic acid and acetophenone, from which it may well be formed in the plant:—

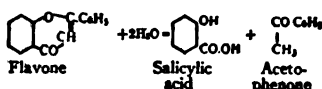

The plant yellows are hydroxy-derivatives of flavone, varying in the manner and position of the hydroxyl groups; but whilst some are flavones in which these groups are contained only in the benzene sections of the molecule, others are flavenols, i.e. derivatives of the simple hydroxy-compound

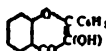

The plant colouring matters other than the yellows which are now generally grouped as anthocyan colours, are derived from the yellows by a very simple process—merely by reduction, a process, however, which involves their conversion into derivatives of ortho-quinone, as shown by the following equation representing the change of the flavonol quartin into cyanin chloride:—

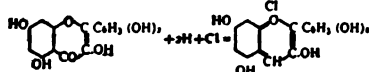

The colour produced by an anthocyan depends not only on the number and position of the hydroxyl groups but also on its condition in the plant cell—whether it is present in combination with acid or as a salt.

**Nuclear Materials.**—Substances which play a determining part as structural elements, if not as functional agents, are far more complex. The nucleic acids are the chief. Nucleic acid, from yeast or the wheat embryo, for example, which has the formula  $\text{C}_{10}\text{H}_{16}\text{O}_{10}\text{N}_4\text{C}_6$ , may be resolved into four sections known as nucleotides, all of which have been isolated and studied of late years, particularly by the American chemists, Levene and others. Each of these nucleotides consists of the peculiar pentose, ribose, associated, on the one hand, with phosphoric acid, on the other, with a purine base (a compound of the uric acid series), the two former being common to all four sections but each having its special basic constituent, namely, one of the following:—

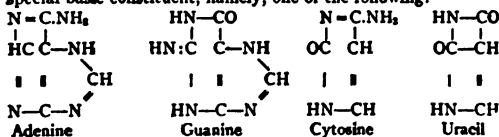

Nucleic acid of animal origin contains a hexose in place of the pentose, ribose; moreover, the basic elements are not all the same, methyluracil (thymine) taking the place of uracil.

The formula assigned to plant nucleic acid is:—

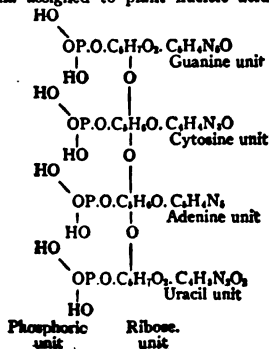

Complex materials thus constituted, comprising acid, neutral and basic sections, this last of varying structure, obviously must offer numerous attractions such as befit a nuclear substance; probably, however, the phosphoric units are the main functional elements, and it is in these compounds particularly that the special value of phosphoric acid to the living organism is apparent. The nucleins are accompanied by a number of enzymes which, doubtless, are concerned in their formation; these suffice not only to resolve them, when necessary, into their proximate components but also to convert the basic units into uric acid.

**The Proteins.**—The fundamental phenomena of vital activity are best studied, at present, with the aid of carbohydrate material, because of its greater simplicity; there is, however, every reason to suppose that, in the main, the same considerations apply to the problems offered by nitrogenous materials. The possibilities are more numerous but the lines of action and reaction are of the same order. The texture and configuration of carbohydrate material cannot be greatly varied; although, as shown in artificial silk, cellulose has strength and a world might be built of carbohydrate material, it would undoubtedly display great poverty of pattern and less colour. The introduction of nitrogen has added enormously to structural variety and strength. Elsewhere the complex carbohydrates have been compared with pavements of simple mosaic; the proteins, which play so large a part, especially in animal life, are more like a jig-saw puzzle.

The proteins are the formative materials of animal structures. They are commonly known in such materials as wheat gluten—easily separated from the accompanying starch by kneading flour in a gently-running stream of water, egg white; milk casein; glue or gelatin; and as the chief constituent of meats. A number of proteins have been obtained in crystalline form, but they are undoubtedly all substances of high molecular weight. Like the higher carbohydrates they can be resolved into simple units by hydrolysis either by acids or by enzymes. They yield a numerous and varied series of fragments; the following is a list of compounds of the glycine type thus far separated from them:—

- Glycine  $\text{CH}_2(\text{NH}_2).\text{COOH}$
- Alanine  $\text{CH}_3.\text{CH}(\text{NH}_2).\text{COOH}$
- Valine  $(\text{CH}_3)_2.\text{CH}.\text{CH}(\text{NH}_2).\text{COOH}$
- Leucine  $(\text{CH}_3)_2.\text{CH}.\text{CH}_2.\text{CH}(\text{NH}_2).\text{COOH}$
- Isoleucine  $(\text{CH}_3)(\text{C}_2\text{H}_5).\text{CH}.\text{CH}(\text{NH}_2).\text{COOH}$
- Serine  $\text{CH}_2\text{OH}.\text{CH}(\text{NH}_2).\text{COOH}$
- Lysine  $\text{H}_2\text{N}.\text{CH}_2.\text{CH}_2.\text{CH}_2.\text{CH}(\text{NH}_2).\text{COOH}$

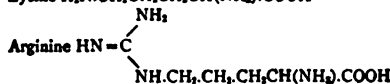

- Phenylalanine  $\text{C}_6\text{H}_5.\text{CH}_2.\text{CH}(\text{NH}_2).\text{COOH}$
- Tyrosine  $\text{HO}.\text{C}_6\text{H}_4.\text{CH}_2.\text{CH}(\text{NH}_2).\text{COOH}$
- Aspartic acid  $\text{HOOC}.\text{CH}_2.\text{CH}(\text{NH}_2).\text{COOH}$
- Glutamic acid  $\text{HOOC}.\text{CH}_2.\text{CH}_2.\text{CH}(\text{NH}_2).\text{COOH}$
- Hydroxyglutamic acid  $\text{HOOC}.\text{CH}_2.\text{CHOH}.\text{CH}(\text{NH}_2).\text{COOH}$
- Cystine  $\text{HOOC}.\text{CH}(\text{NH}_2).\text{CH}_2\text{S} - \text{SCH}_2.\text{CH}(\text{NH}_2).\text{COOH}$
- Proline  $\text{CH}_2 - \text{CH}_2$

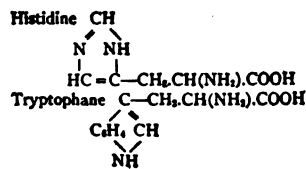
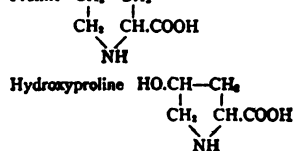



It is not difficult to account for the formation of such compounds from carbohydrate materials and ammonia. Peculiar to all is the group  $\text{CH}(\text{NH}_2)\text{CO}_2\text{H}$ . The presence of this group is almost certainly a clue to the process by which they are produced, viz. by the action of ammonia on a keto-carboxy-acid. Much has been said above of pyruvic acid; alanine is doubtless formed from this acid by its combination with ammonia and subsequent reduction of the hydroxy-amino acid:—

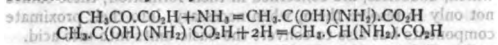

In the human circulation amino-acids are converted into oxo-acids—which serve as fuels—by the reverse process. As the amino-acids are optically active substances, like the glucosides, the reduction process must be directed in some way; they belong to one series corresponding to that of the natural sugars. The name amino-acid, usually given to the protein hydroclasts, is not applicable to the compounds as they exist apart, although they function as such. The names in the above list, which are those usually given, indicate that most of the compounds are basic rather than acid. As a matter of fact, owing to internal neutralization,

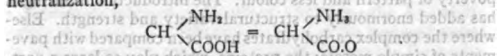

they are all but neutral substances, yet they can act either as acid or base, according to circumstances.

Although obtainable from animal as well as vegetable proteins, all the compounds in the list given, with the exception of the first, are the products of plant activity alone. The office of the animal is to take to pieces the complex structures which are eaten as vegetable food, then, having conveyed them in the blood stream to various parts of the body, to reconstruct them in appropriate special ways. In some cases the units are built up around a phosphoric acid nucleus, particularly in cell nuclei, in brain matter and bone marrow. A number of compounds besides those in the list, even sugars, especially galactose and ribose, are met with proteins.

In the carbohydrates the linkage is etheric—two carbon atoms are joined through the agency of an oxygen atom. In the proteins two carbon atoms are linked together through the agency of a nitrogen atom. An additional peculiarity is the presence of a succession of  $\text{NH}_2\text{CH}_2\text{CO}$  groups, each forming as it were a short link in a chain, each link carrying a side-group—which may vary greatly in character and dimensions—attached to the CH member. A large number of "polypeptides" have been built up in the laboratory, from amino-acids, on such a plan as the following:—

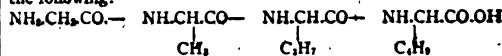

Even octadecapeptides have been prepared, indeed there seems to be no theoretical limit to the number of "links" that may be included in the chain. In this field however, as in that of the carbohydrates, there is reason to believe that nature has been sparing in her selection and choice of patterns. At present, not the least clue to the patterns laid down has been obtained: at most the order followed in some of the smaller fragments obtained from proteins by hydrolysis has been ascertained.

The uniformity that exists could not be reached—the possible permutations and combinations are so infinitely numerous—if selective and directive influences were not at work, of the order of those referred to in discussing the carbohydrates. It would be easy to prepare many unit materials similar to those in use in plants and animals, but there can be no doubt they would not be assimilated as foods. If not poisonous they would either be seized on by glucose molecules and quickly emptied into the urine or got rid of as such; or they would be just thrown into the circulation and burnt up in its fires.

The great advance of modern times, since it became possible to analyse the proteins, is the recognition of the prime fact that a varied and well proportioned diet is essential, if all the structural elements required in growth are to be at disposal. Lately the even more important discovery has been made that fresh and uncooked foods contain minute proportions of mysterious materials

	Ox Muscle Protein.	Casein.	Lact-albumin.	Gelatin.	Wheat Gliadin.	Wheat Glutenin.	Majze Zein.	Majze Glutenin.	Edestin.	Sturin.
Glycine	2.1	0	0	19.3	0	0.9	0	0.3	3.8	
Alanine	3.7	1.5	2.5	3.0	2.0	4.7	9.8		3.6	
Valine	0.8	7.2	0.9		3.4	0.2	1.9		+	
Leucine	11.7	9.4	19.4	6.8	6.6	6.0	19.6	6.2	20.9	
Phenylalanine	3.2	3.2	2.4	1.0	2.4	2.0	6.6		3.1	
Tyrosine	2.2	4.5	0.9	0	1.2	4.3	3.6	3.8	2.1	
Serine		0.5		0.4	0.2	0.7	1.0		0.3	
Cystine		(?)		0	0.5	0.02			4.1	
Proline	5.8		4.0	10.4	13.2	4.2	9.0	5.9	2.0	
Hydroxyproline		0.3		6.4					2.0	
Aspartic acid	4.5	1.4	1.0	1.2	0.6	0.9	1.7	0.7	4.5	
Glutamic acid	15.5	15.6	10.1	1.8	43.7	23.4	26.2	12.7	18.7	
Tryptophane	+	1.5		0	1.0	+	0	+	+	
Arginine	7.5	3.8	3.2	9.3	3.2	4.7	1.6	7.1	14.4	58.2
Lysine	7.6	6.0	9.2	5.0	0.2	1.9	0	3.0	1.7	12.0
Histidine	1.8	2.5	2.1	0.4	0.6	1.8	0.8	3.0	2.4	12.9
Ammonia	1.1	1.6	1.3	0.4	5.2	4.0	3.6	2.1		
Total	67.5	66.5	57.0	65.4	83.0	59.72	85.4	45.7	81.9	83.1

The analysis of the proteins is a difficult operation and the results are usually but approximations. In the accompanying table, the results of such an analysis are set out. Those quoted are sufficient to show how complex is their composition and how much variation there is in the proportions of the several components.

Like the higher carbohydrates, the proteins may be broken up into a series of compounds of diminishing complexity by means of several different enzymes acting in succession; these proteolytic enzymes have been relatively little studied and but imperfectly defined. A striking peculiarity of several is that they are active either in strongly acid or strongly alkaline solutions under conditions which render the saccharolytic enzymes inoperative. This difference is called for probably because of the different way in which the units are linked.

without which healthy growth is impossible. These indispensable agents or adjuvants may easily be destroyed in cooking and by preserving foods. Thus infants fed on boiled milk alone rapidly develop symptoms of scurvy, but the addition of a little orange or turnip juice is sufficient to meet the deficiency. To explain such facts and a multitude of similar observations is very difficult, yet the discovery of the explanation is of vital importance, as vast quantities of poor food might have its full value restored, if the deficit in adjuvant could be made good.

The adjuvants can scarcely be enzymic agents, as in most cases they withstand more heating than would an enzyme: it is true the antiscorbutic adjuvant in milk and fresh vegetables is destroyed by heating or drying, but in orange juice survives boiling.

The alkaloid adrenaline, produced constantly in minute proportion, is known to be a regulator of the arterial system in the

human body; therefore, it is conceivable that the advitants are alkaloidal substances or at least substances which exercise regulative functions without being structural elements.

The most suggestive observations of recent times in this direction, however, are those relating to anaphylaxis. If a minute amount of a protein be introduced into the blood stream of an animal, after a certain interval it is rendered so sensitive to the action of the particular protein that if a further amount be injected the animal is killed. A different protein has no lethal effect. In this way a clear distinction can be established between such apparently similar materials as white of egg from the hen and that from the duck. Nay more according to Dakin and Dale—if egg albumin be treated with weak alkali and the treated material be injected into the animal it produces no sensitiveness either to itself or to untreated egg albumin, and animals sensitised by the latter are not affected by it. The effect of alkali, it is known, is to racemise the albumin; that is to say, to bring about a local change such as that which attends the conversion of glucose into galactose; in the albumin only a few centres can be open to such a change, yet its fit is spoilt thereby and it is no longer operative in the system but runs out unchanged in the urine.

Even in the case of adrenaline only the natural form is operative; the optically opposite form—the other glove—has little effect. Attention may be called here to a striking recent observation in connexion with this alkaloid. When tellurium is combined with methylic iodide two isomeric compounds are formed, differing in colour and crystalline form: in itself this is a remarkable result and proof that tellurium has unsymmetric affinities. The two compounds are probably *cis*- and *trans*-forms, thus:—

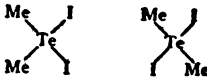

These produce entirely different effects on animals: the one, presumably the *trans*-form, slows and weakens the heart and the blood-pressure falls. The other, in which the iodine atoms perhaps act together, has the most profound stimulant action on the medulla, giving rise to an increase of blood-pressure and increasing the depth and rapidity of respiration. Generally, before the blood has reached the normal again, a second rise occurs; this is due to the liberation of adrenaline from the supra-renal glands, upon which the *cis*-compound exerts an unique and specific effect not comparable with that produced by any other known chemical. Large doses of the compound, such as 60 milligrammes to a cat, paralyse the whole nervous system—brain, spinal cord and motor nerves (cf. Vernon, *Journ. Chem. Soc.*, 1921, 108).

This effect may be likened to that of secretin, which according to Bayliss and Starling serves to liberate from the pancreas the proteolytic enzyme which is active in intestinal digestion.

In fine, whatever the direction in which we look, the influence of structure is paramount and determinative: hence the fixity of our human nature. If organic chemistry teaches us anything it is that no education can alter our mechanism: only changes in the germ can be effective: wherein the patterns are laid down in proteins especially, and so handed on from generation to generation. (H. E. A.)

**CHESTERTON, GILBERT KEITH** (1874— ), English author (see 6.111). More recent works:—*The Innocence of Father Brown* (1911) and *The Wisdom of Father Brown* (1914), both collections of detective stories; *Man Alive* (1912); *The Victorian Age in Literature* (1913); *The Flying Inn* (1914); *A Short History of England* (1917); *Irish Impressions* (1919) and a play, *Magic* (1913), which was produced at the Little Theatre, London.

**CHEYNE, THOMAS KELLY** (1841—1915), English divine and biblical critic (see 6.116), died at Oxford Feb. 16 1915. His later works include *The Two Religions of Israel* (1910); *Mines of Isaiah Re-explored* (1912); *The Veil of Hebrew History* (1913) and *Fresh Voyages on Infrequented Waters* (1914).

**CHEYNE, SIR WILLIAM WATSON, 1st BART.** (1859— ), British surgeon, was born in the Shetland Is. Dec. 14 1852

and was educated at Edinburgh, where he took his degrees in surgery and medicine in 1875. He also studied at Vienna, Paris and Strasbourg. In 1880 he was appointed to the chair of surgery at King's College, London, and from 1888 to 1890 was Hunterian professor of surgery at the Royal College of Surgeons. From 1900 to 1901 he was consulting surgeon to the South African forces. On the outbreak of war in 1914 he became consulting surgeon to the Royal Navy and in this capacity accompanied the British forces to Gallipoli. He was created a baronet in 1908 and in 1916 received the K.C.M.G.

His published works include *Antiseptic Surgery* (1882); *The Antiseptic Treatment of Wounds* (1885); *Lectures on Suppuration and Septic Disease* (1889); *Objects and Limits of Operations for Cancer* (1896); *Manual of Surgical Treatment* (7 vols., 1899—1903); besides various papers on the treatment of wounds in war.

**CHICAGO** (see 6.118).—With a pop. in 1920 of 2,701,705, representing an increase of 23.6% over the enumeration for 1910 (2,185,283), Chicago easily maintained its position as the second city in the United States. While the city's growth was greater proportionately than that of New York, which was 17.9%, it was considerably less absolutely. The percentage of increase was less than in any other decade of Chicago's history. It was likewise smaller than that of Detroit, 115.4%, and Cleveland, 42.1%, Chicago's closest rivals in the Middle West. In 1920 the negro pop. was 109,594, an increase of 148.5% over the preceding census. This influx of negroes, largely from the South, was due to the great demand for unskilled labour, especially in the packing industry, during the period of the World War when the European immigration was slight. A shortage of housing facilities for these negro labourers was one of the underlying causes of the race riots of 1919 in which a number of negroes and whites were killed. Much of Chicago's growth in previous decades had been due to immigration; this was sharply restricted after 1914. By the annexation of suburban territory, the area of Chicago (both land and water) was increased from 191.4 sq. m. in 1910 to 200 sq. m. in 1920.

*Industry and Commerce.*—The value of manufactures produced in Chicago increased enormously during the decade, the greatest advance being after 1914, as indicated by the following table compiled by the Chicago Association of Commerce in which, however, the estimates for 1919 are probably too generous:—

## LEADING MANUFACTURERS

Industry.	1919 (Estimated)	1914 (U.S. Census)
All industries	\$6,500,000,000	\$1,482,814,000
Meat packing	3,500,000,000	410,709,000
Iron and steel	600,000,000	27,002,000
Foundry products	265,000,000	85,359,000
Men's clothing	252,000,000	84,340,000
Printing and publishing	203,000,000	97,507,000
Electrical machinery	184,000,000	17,568,000
Agricultural implements	130,000,000	41,000,000
Railway cars	126,500,000	50,931,000
Plumbing, etc.	111,500,000	
Furniture	102,000,000	43,600,000
Timber products	73,000,000	28,711,000
Bakery products	68,500,000	34,217,000
Soap	59,500,000	21,255,000

In 1918 the estimated total for all industries was \$4,205,914,000. In 1914 Chicago had 10,114 manufacturing establishments employing 386,794 persons, of whom 313,202 were wage earners. The cost of materials was \$793,470,000, and the amount paid in wages \$174,112,000. The Chicago packing plants increased their output while the World War was in progress, as the following figures show:—

## BEEF AND PORK PACKING IN CHICAGO

	No. cattle.	No. hogs.	1915-6	No. cattle	No. hogs.
1905-6	1,998,955	6,027,432		1,962,048	7,256,936
1910-1	1,735,185	6,294,251	1916-7	2,073,553	7,757,726
1914-5	1,442,870	6,079,473	1917-8	2,411,750	6,284,586

The extent of the grain trade is indicated by the following tabulation of receipts (bus.):—

	1913	1915	1918
Wheat	50,372,000	70,704,000	69,610,000
Corn	127,773,000	95,373,000	100,409,000
Oats	124,405,000	133,475,000	137,072,000

Bank clearings in 1920 were \$32,669,233,535, as compared with \$16,198,985,174 in 1915 and \$13,939,689,984 in 1910. The combined resources shown by the figures of the Chicago banks in 1920 amounted to \$1,883,154,592.

**The City Plan.**—The most striking feature of Chicago's recent history is the formulation of the plan for the physical reconstruction of the city and the progress of the movement for its execution. This plan had its genesis in a report, issued by the Commercial Club of Chicago in 1909, which was prepared largely under the guiding spirit of Mr. Daniel H. Burnham, Director of Works of the World's Fair of 1893. The first step was the appointment of the Chicago Plan Commission, created by ordinance of the city council, and composed of aldermen and citizens. In furtherance of the Chicago Plan, Roosevelt Rd. (formerly 12th St.) was widened to more than 100 ft. between Ashland Ave. and Michigan Ave., a distance of 2 m., at a cost of \$8,303,284. Michigan Ave. was widened to 130 ft. between Roosevelt Rd. and the river and to 141 ft. between the river and Chicago Ave. Widening that part of the street between Randolph St. and Chicago Ave. was a difficult matter, involving the taking of valuable private property, and the construction over the Chicago river of a large two-level bascule bridge. The cost of the Michigan Ave. project was in excess of \$16,000,000, paid for out of bond issues and special assessments. The new thoroughfare was opened to traffic in 1920. Other street-widening and street-opening projects were under way in 1921.

The situation with respect to railway terminal facilities had long been unsatisfactory. The fact that Chicago is the greatest railway centre in the world, and that the interests involved were conflicting, made the problem exceedingly difficult. In 1911 the new passenger station of the Chicago and Northwestern railway was opened to service, at a cost of \$25,000,000. This station, which is a dignified structure, was the project of a single railway. Other terminal projects authorized later represent greater cooperation, though they materially conflicted in some respects with the ideas of the Chicago Plan Commission.

The railways using the so-called Union Station—the Pennsylvania, the Burlington, the Chicago & Alton, and the Chicago, Milwaukee & St. Paul—had under construction (1921) a new passenger station estimated before the war to cost \$65,000,000. The actual cost probably will be nearer \$80,000,000. This station is to have a large office building above it. The proposed passenger station of the Illinois Central railway, on the lake front, was planned on a scale large enough to accommodate all the roads—17 in number—using the Illinois Central, Dearborn, La Salle and Grand Central stations. The Illinois Central project also involved a programme of electric operation, beginning with the suburban service in 1927 and including all service, freight and passenger, by 1940. The estimated cost to the railway of the Illinois Central improvement was \$80,000,000.

As a part of the combined move for terminal improvement and lake-front development, the Board of South Park Commissioners planned to spend \$60,000,000, of which \$20,000,000 has been authorized by referendum vote. The board was, in 1921, proceeding to make land by filling the lake outside the Illinois Central right of way, this land to be used for parkways and bathing beaches. The new building for the Field Museum, located on made land on the lake front at the foot of Roosevelt Rd., was completed in 1920 at a cost of \$6,000,000, which was provided by the will of Marshall Field. The museum was formerly housed in the old Fine Arts Building, first erected for the World's Fair of 1893, in Jackson Park. The new building opened in May 1921 is 350 ft. wide and 700 ft. long. It is built of Georgia white marble, in the Ionic style of architecture. South of the Field Museum is to be located a large stadium with a seating capacity of 100,000, for which a bond issue of \$2,500,000 has been authorized by referendum vote. The outside dimensions of this structure of reinforced concrete will be 2,000 by 1,080 feet. Other important buildings erected or completed during the decade 1910-20 include the following, (name, height in storeys and approximate cost given in order): Atlantic Hotel, 20, \$1,400,000; Butler Bros., 14, \$1,750,000; Continental and Commercial National Bank, 20, \$4,500,000; Fort Dearborn Hotel, 17, \$1,100,000; Insurance Exchange, 22, \$3,000,000; Karpen, 12, \$1,400,000; Lytton, 18, \$2,250,000; Mandel (department store), 15, \$2,000,000; Monroe, 14, \$1,500,000; Morrison Hotel, 22, \$2,000,000; North American, 20, \$1,800,000; Peoples Gas, 20, \$3,000,000; State-Lake, 13, \$1,600,000. The present limit of the height of buildings by city ordinance is 260 feet.

One of the most important municipal undertakings of the decade was the Municipal Tuberculosis Sanatorium, consisting of several buildings erected after 1909, in which year a site of 164 ac. was acquired in the north-western part of the city. Its revenues, derived

mainly from taxation, amount to more than \$1,000,000 a year; in 1920 there were about 1,000 patients. A notable structure, completed late in 1915 at a cost of nearly \$4,000,000, is the Municipal Pier. It projects 3,000 ft. into Lake Michigan just north of the mouth of the Chicago river. The outer portion, 660 ft. in length, is a three-decked structure devoted to recreation purposes. Up to 1920 the new pier had not been extensively utilized by shipping interests; the recreation part of the pier, however, proved extremely popular from the outset.

**Education, Art and Music.**—The school census of 1916, though not completely reliable, was of interest as showing that the total pop. under 21 years of age, in that year was 996,059. Of these 304,547 were of compulsory school attendance age *i. e.* over 7 and under 14 years. Between the ages of 14 and 16 there were 95,949 of whom 15,393 were at work and 885 unaccounted for. The total enrolment in the public schools in 1919 was 377,058 (8,558 teachers); in 1910 the enrolment was 300,893 (6,383 teachers). In 1920 there were 288 public schools, in many of which night courses were given to adults as well as to minors. The number of students registered in the Art School of the Art Institute in 1920-1 was 4,267. The number of visitors to the Institute during the year was 1,100,000.

The trustees of the Art Institute administer the Ferguson Monument Fund, consisting of the income from \$1,000,000, left by the will of Benjamin Franklin Ferguson, a Chicago business man, to be used for the erection of enduring statues and monuments in Chicago. Among others two notable pieces by Lorado Taft have been purchased; one, "The Fountain of the Great Lakes," stands just to the S. of the Art Institute; the other, "The Fountain of Time," will stand at the head of the Midway, between Washington and Jackson parks.

Chicago was the first American municipality to adopt the policy of giving direct official encouragement to local art by using public funds for that purpose. In 1914, at the suggestion of Mayor Harrison, the city council appropriated \$2,500 for the purchase of paintings and works of plastic art, the production of resident artists and sculptors, and an appropriation for this purpose has been made each year since. The purchases are supervised by a commission named by the mayor; it consists of seven members, of whom six are appointed on the recommendation of different art groups of the city, including the Art Institute.

The most notable development in music since 1910 has been the establishment of the Chicago Opera Association, at first known as the Chicago Grand Opera Co. The company gives a 10 weeks' season of grand opera each year in Chicago, five weeks in New York and five weeks in other places.

**Parks and Bathing Beaches.**—Before 1910 the facilities for bathing in Lake Michigan within the city limits were meagre. In 1920 there were 12 public bathing beaches, 3 being managed by park boards, and the rest by the city government. Clarendon Beach, managed by the city, is the largest. It has nearly 10,000 lockers and has been used by as many as 23,000 bathers in one day. The small park and playground movement, which was well under way in 1910, developed largely in the following decade. In 1920, in addition to several large parks, there were 195 small parks and playgrounds maintained by the city and by park authorities. Outer park areas for Chicago were enlarged by the purchase, beginning in 1916, of wooded tracts in Cook county, nearly all of them outside Chicago, to the extent of 18,028.77 ac.; these tracts are known as the Forest Preserve District. The total purchase price was \$7,221,754.78, or an average of \$400.57 per acre. The members of the Board of Cook County Commissioners are *ex-officio* the commissioners of the Forest Preserve District. The plans call for the acquisition of about 30,000 ac. all told. A 300-ac. tract of land near Riverside was donated by Mrs. Edith Rockefeller McCormick for the establishment of the Chicago Zoological gardens.

**Finance.**—The city's corporate finances suffered severely from causes incident to the World War, and more particularly from the loss of revenue from saloon licenses, which once contributed as much as \$7,000,000 annually. A summary of the more important city revenues and expenditures in 1919 follows:—

Purpose.	Revenue.	Expenditure.
Corporate purposes . . . . .	\$32,541,758	\$32,084,658
Sinking-funds for bonds . . . . .	4,324,346	4,200,346
Municipal water-works . . . . .	8,007,851	6,643,958
Schools . . . . .	27,701,826	24,167,352
Public Library . . . . .	847,095	848,704
Municipal tuberculosis sanatorium . . . . .	1,054,076	1,287,753
Special assessments (street improve- ments) . . . . .	10,757,148	9,449,038
All purposes <sup>1</sup> . . . . .	129,432,896	99,142,349

<sup>1</sup> This does not include expenditures for the larger parks, for the sanitary district, or for some other purposes which are in the hands of separate taxing bodies. The division of each dollar of taxes in 1918 was as follows: city, corporate, 17¢; state, 14¢; county and towns, 9¢; sanitary district, 5¢; schools and education, 19¢; school buildings, 10¢; parks, 10¢; tuberculosis sanatorium, 1¢; pensions, 2¢; public library, 1¢; and interest, 9¢.

*History.*—Carter H. Harrison (Dem.), who was elected in 1911 to his fifth term as mayor of Chicago, was succeeded in 1915 by William Hale Thompson (Rep.), who was reelected in 1919. After the United States entered the World War, Thompson was sharply criticised for various actions that seemed to indicate a reluctant support of the war policy of the Government.

The disappearance from the newspaper field of the *Inter-Ocean* and the *Herald* left Chicago for a time with only two English-speaking morning dailies, the *Tribune* and the *Herald and Examiner*. In 1920 the Chicago *Journal of Commerce* was established as a morning paper for business men, with no Sunday edition. The Joseph Medill School of Journalism was opened in Feb. 1921, with over 100 students, as a part of the Northwestern University. The Chicago *Tribune*, of which Joseph Medill was founder, agreed to underwrite the deficit of the school for a five-year period.

**CHICAGO, UNIVERSITY OF** (see 6.125).—The grounds of the University of Chicago increased between 1908 and 1920 from 60 ac. to 92, so that the university's holdings occupied both sides of the Midway Plaisance continuously for three-quarters of a mile. During the same period new buildings were erected, at an aggregate cost of \$2,000,000, for a general library (the William Rainey Harper Memorial), for classics, for geology and geography (Julius Rosenwald Hall), for pathology (the Howard Taylor Ricketts Laboratory), and for a women's gymnasium, refectory and clubhouse (Ida Noyes Hall). Funds amounting to \$3,250,000 were in hand in Jan. 1921 for further building projects—a theology building and chapel, the Rawson laboratory for medical research, the Billings hospital (25 beds) and the Epstein dispensary, and the founder's chapel. In 1916-7 funds amounting to \$5,461,000 were secured for the development of the medical work of the university, and arrangements were made for the closest cooperation with the Presbyterian hospital, the Otho S. A. Sprague Memorial Institute and the McCormick Memorial Institute. A Graduate School of Social Service Administration, continuing and developing the work previously done by the Chicago School of Civics and Philanthropy, was added to the schools by the university in 1920.

The libraries of the university contained in 1920 685,000 volumes and 200,000 pamphlets. By a novel arrangement of bridges connecting the third floor of the Harper library with adjacent buildings, reading rooms with an aggregate capacity of 900 readers were brought into connexion upon the same level and virtually under one roof. The University Press, the first to be organized under university ownership in the United States, publishes from 30 to 60 books annually, and 11 scientific journals, the *Biblical World* and the *American Journal of Theology* giving way on Jan. 1 1921 to the *American Journal of Religion*. Beginning in 1914 the Meadville Theological School united its summer quarter with that of the Divinity School, and in 1915 the Chicago Theological Seminary (Congregational) became affiliated with the university. While the trustees of the Divinity School were Baptists, theological instruction was given by members of five Protestant denominations to students of every denomination. In celebration of the quarter-centennial of the founding of the university, June 2-6 1916, the university published three volumes: *The Quarter-Centennial Celebration of the University of Chicago, 1916*, by D. A. Robertson; *A Bibliography of the Publications of Members of the University, 1902-1916*, edited by G. J. Laing; and *A History of the University of Chicago, 1891-1916*, by T. W. Goodspeed.

Upon the entrance of the United States into the World War, the President placed the resources of the university at the disposal of the Government for purposes of experimentation and research and for military training, and the members of the university entered actively into war work. President Judson himself led a political and philanthropic mission to Persia in 1918-9, and, in all, 4,355 members of the university, including students, alumni, and members of the faculties were in the service of the Government; 70 of these gave up their lives for their country. Between 1908 and 1920, under the administration of President Judson, the university's total resources more than doubled, and on June 30 1920 exceeded \$50,000,000, rather more than \$30,000,000 of which was in invested funds. The members of the faculties numbered 328. Between 1892 and 1920 87,600 students matriculated and more than 12,000 took degrees, 1,200 of them the Ph.D. In 1920-1 the university enrolled 11,479 students. (E. J. G.)

**CHILD LABOUR:** see JUVENILE EMPLOYMENT.

**CHILDREN, LAW RELATING TO** (see 6.138).—In the United Kingdom little actual legislation for child welfare was passed

between 1908 and 1920, but an immense work was done by the National Society for the Prevention of Cruelty to Children, which now has branches all over the United Kingdom. The worst as well as the most numerous cases of cruelty take place at home; parents and step-parents are worse than employers. The society, authorized by name in the "Children's Charter" (Children Act 1908), was founded at a meeting at the Mansion House in 1884 and dealt with 95 cases in that year. The number of cases dealt with in the year ending March 31 1921 was 38,174 in England, Ireland and Wales, but this was 16,598 less than in 1913-4. The number of children involved was 101,085. Only 3% of the cases were brought into court. Out of 1,140 prosecutions only 22 failed. The cases are thus divided:—

	Cases investigated.
Neglect or starvation . . . . .	33,089
Ill-treatment . . . . .	3,036
Exposure, abandonment, etc. . . . .	398
Moral wrongs . . . . .	541

Cases where improvement took place by warning were 33,757 or 88.4% of the whole. More than half of these cases (22,095) were reported by the general public; reported by the police, 3,205; school officials, 6,584; other officials, 3,936. Discovery by inspectors, 2,354. The children died in 533 cases in consequence of neglect or cruelty.

By the Children Act 1908 any person "over the age of 16 years who has the custody, charge or care of any child under 16 years of age and who causes or procures such child to be assaulted, ill-treated, neglected, abandoned or exposed in a manner likely to cause such child unnecessary suffering or injury to its health including injury to or loss of sight or hearing, limb or organ of the body and any mental derangement" can be punished at the Assizes by fine of £100, and two years' imprisonment, with or without hard labour, or before a police magistrate by fine of £25 and imprisonment for six months. The punishment may be ordered although the child be dead. If the defendant was directly or indirectly interested in any money payable on the death of the child (e.g. insurance) the fine can be raised to £200 and five years' penal servitude can be inflicted. Restrictions are also placed on employment of boys under 14 or girls under 16 for begging or performing or selling anything in any street, public place, or show (Sect. 2) except under licence if over the age of 10 years. Application for a licence requires the consent of the police and also the Local Education Authority (Rules 1920). A constable may take any child to a place of safety pending trial of an offence under the Act (Sect. 5), and the magistrate may order the detention of the child by a relative, or in a home. After conviction the court can remove the child out of the control of the offender and hand it over to a suitable guardian, including a society. There is also a provision for emigration. The parent of the child can also be ordered to contribute to its maintenance, and any pension or source of income may be utilized and charged for the purpose. The religion of the child is protected (Sect. 8). A search warrant may be issued (Sect. 10) in cases where cruelty to a child is suspected, but the child cannot be communicated with. The magistrate may take the evidence of the child by deposition and not in the open court, on a medical certificate. Evidence of a child of tender years may be taken although the child is not able to understand the nature of an oath, but there must be some circumstance or other person to corroborate such evidence. The court may dispense with the attendance of the child. The onus of proving that the child is older than 16 is (Sect. 7) thrown on the defendant. The prosecution must be within six months of the offence. Besides the offences specified in Sect. 1 of the Act certain other violent and criminal offences against the person under an Act of 1861 and the Criminal Law Amendment Act 1885 are also punishable.

**Baby Farming.**—The Act provides for inspection and control. The persons having the care of infants for reward must give notice to the local authority which appoints visitors and inspectors of both sexes and, if thought well, in conjunction with philanthropic societies. Search warrants can be issued, and it is an offence to refuse admittance to a visitor. Persons who have committed an offence under this or previous Acts cannot receive or retain children. The number of children received can be limited. Children can be removed. Notice of death must be given to the coroner. Insurance policies cannot be taken out on the lives of such children.

**Miscellaneous.**—A penalty is imposed for exposing a child to danger of burning or scalding by reason of an open grate (Sect. 15) or for allowing a child to reside in or frequent a brothel. Two years' imprisonment is the penalty for encouraging the seduction or prostitution of a girl under 16 years of age, or for allowing her to consort with or enter the employment of any person of immoral character (Sect. 17). The magistrate may require security from the parent or guardian not to expose the girl to such risk. Further

precautions are provided for the detention of children in safety during trial and for placing them with respectable relations or friends or with societies or industrial schools or reformatories afterwards. In cases of homicide or grave crime the Home Office has to provide special places of detention; one of these is the Borstal Institution at Rochester. The parent is compellable to attend the juvenile court and can be fined in lieu of the child. No sentence of felony or death can be recorded against any person under 16 years of age. Any court may be cleared for a child to give evidence. No child may be present at any trial in which he is not concerned.

No pawnbroker or dealer in old metal may deal with a child under 16.

Vagrants who keep children from school can be fined and the children may be removed to a certified school.

**Liquor.**—By Sect. 119 of the Children Act any person giving a child under the age of five any intoxicating liquor except by doctor's order can be fined £3. No child under 14 can be allowed in a bar, and the licensee or any person bringing the child in may be summoned by the police and fined. Railway and other bonafide refreshment rooms are excepted.

**Entertainments for Children.**—Where the majority of the audience are children and the number exceeds 100 the occupier is responsible and can be fined up to £100. He must provide a sufficient number of adult attendants to take precautions for the safety of the children. His licence may be revoked (Sect. 121).

**Vermineous Children.**—The local authority may direct their medical officer to examine the children in any provided school and remove and cleanse any verminous child after notice to the parent who can be fined on a second offence.

**Presumption of Age.**—The decision of the court on the hearing can be given on such evidence as is available and is final even if direct proof of age is subsequently forthcoming. The onus of proof that the person is over age lies on defendant, and if strictly proved at the time is a good defence.

**Reformatory and Industrial Schools.**—Part IV. of the Act is a code regulating these schools. Briefly, reformatory schools are those provided for youthful offenders between 12 and 16 years of age who have been convicted of some offence punishable in an adult by imprisonment. Industrial schools are those for children under 14 (a) whose parents cannot control them and consent, or (b) who are found begging under any excuse, wandering, destitute, having drunken or criminal parents, or associating with thieves or prostitutes or in immoral surroundings, or (c) children under 12 who, if over 12, might have been sent to a reformatory, or (d) any refractory workhouse child under 14, or child who cannot be made to attend any elementary school. In the alternative any child who could be committed to an industrial school can be committed to a relative or other person nominated by the court. All these schools are inspected and controlled by the Home Office, but they are provided at the expense of the local authority which can borrow in order to provide them. They are certified by the Home Office and the certificate may be withdrawn. Managers are appointed to look after these schools and their expenses are paid. The funds are partly supplied by the Home Office, partly by the parents of the children, partly by the local authority.

**Scotland.**—The Secretary for Scotland is substituted for the Home Office and there are other provisions so as to extend the Act to Scotland. What is called the police court in England is the sheriff's court in Scotland, the workhouse becomes the poorhouse, and the coroner the procurator fiscal.

**Ireland.**—The Act also applies to Ireland.

**Juvenile Courts.**—The most conspicuous advance is the development of juvenile courts, which have been a great success and have been adopted in most towns. The appointment of women magistrates is also a step in advance and an additional good influence. By 10 and 11 Geo. V., C 68 (Dec. 23 1920) a woman justice must sit with the magistrate in a juvenile court. They are chosen from a panel nominated by the Home Office. The idea of the juvenile court is to get the child away from the criminal atmosphere and the kind of public which frequents police courts, and from the procedure in which the terrified child was placed in a high dock surrounded by members of the police force in uniform, too frightened to tell the truth or know what was being said in the case. The proceedings are conducted in a quiet room by a magistrate who tries to get the confidence of the child and act as a father would in a like case.

**Defective Children.**—Much has been done for defective children since 1893. The Board of Education has issued consolidated regulations (Cmd. 677) dealing with:—(a) medical inspection and treatment of children in elementary schools; (b) provision of meals; (c) schools for blind, deaf, defective and epileptic children; (d) physical training; (e) evening play centres.

These various activities for the benefit of children are taken into consideration in "substantive grants" by the Board of Education

to local authorities. The evening play centres, initiated by Mr. Humphry Ward, and largely supported by voluntary contributions, since 1918 have been eligible for such grants. Submission of arrangements (see Education Act 1918, and Ministry of Health Act 1919) are made by each local authority to the Board or Ministry concerned. Medical records are kept, school clinics and feeding centres are provided, as are special schools for the deaf and blind who must be kept completely separate, and the mentally deficient and epileptic. The necessity of beginning the training between the ages of two and five is insisted on by the Board. The curriculum for each class of child, building regulations, rules as to grants regulation for special schools and boarding-houses will be found in the appendices to the consolidated regulations. The Elementary Education (Defective and Epileptic Children) Act 1899-1914 makes it a duty of the local authority to provide for their education, and make it incumbent on the parent of such a child over seven to make suitable provision for its education or to send it to a certified school.

**Affiliation** (see 1,300).—The maximum payment obtainable from the father of an illegitimate child was in 1921 increased to 10s. per week, to be collected by an officer of the court.

**Adoption.**—In 1921 the Report of the Committee appointed by the Home Office was published (Cmd. 1234). It recommends:—(1) that adoption of children should be made a legal and enforceable act, the adopting parents having the rights of natural parents; (2) that the county court as well as high court should have jurisdiction; (3) that subsequent marriage should legitimize any children previously born.

For the law as to custody and guardianship of children, see WOMEN, LEGAL STATUS OF. (R. Tā.)

#### UNITED STATES

There was a distinct advance in regard to the care of children, legislative and otherwise, in the United States during the decade 1910-20. In 1912 the Federal Children's Bureau was established by Act of Congress as a division of what was then the Department of Commerce and Labor. The Bureau was made a part of the Department of Labor when the latter was created in 1913. The Bureau was directed by statute to investigate all matters pertaining to the welfare of children and child life, and especially the questions of infant mortality, the diseases of children, juvenile courts, abandonment, and the employment of children in dangerous and other occupations. Miss Julia C. Lathrop (b. 1858), chief of the Children's Bureau from its establishment, was responsible for its success in scientific research and in coöperating with national societies and local public and private agencies in the advancement of the interests of children.

**Children's Codes.**—The new movement for "children's codes" took form in 1911, when Ohio was the first state to create an official Children's Code Commission to "revise, consolidate and suggest amendments" to the laws of the state pertaining to children. As a result of the work of this commission, a children's code was adopted by Ohio in 1913. By 1921, 24 states had followed the example by appointing official bodies to codify laws and to recommend legislation in the field of child welfare. Special attention was given by these commissions to the laws with reference to dependent, delinquent and defective children. The legislation which was adopted after the report of the Minnesota Commission in 1917 made Minnesota a leading state in the public protection and care of children. Here, as in seven other states, the work is centralized in a special division, a state board of control or whatever state department has general oversight of the state's wards.

**Illegitimacy.**—There has been some discussion in recent years of the legal position of children born out of wedlock. Most of the American states adopted laws which made the issue of certain annulled marriages legitimate, followed the civil-law principle of legitimation by subsequent matrimony, and created rights of interstate succession between the illegitimate child and the mother. Bastardy support legislation in America has followed English lines. According to Prof. Ernst Freund, of the university of Chicago, the most striking feature of this legislation has been its stationary character, indicative of a lack of thought with reference to the subject during the past century. This stagnation appears to have come to an end in the last few years. In 1917 liberal laws were adopted in the states of Minnesota and North Dakota. The Minnesota law provides that the state Board of Control shall look after the interests of the illegitimate child so that he may have approximately the same advantages as the legitimate child. To do this the Board may initiate proceedings to establish the parentage and rights of the child, may cooperate with child-siding organizations, and, when requested to do so, may appoint a county child-welfare board, two members of which shall be women, to aid in the objects of the state Board; if there is no county welfare board, the judge of the juvenile court may appoint local agents to

cooperate with the state Board. The abandonment statute is made applicable to illegitimate as well as to legitimate children. North Dakota has by legislation declared every child born out of wedlock to be legitimate and entitled to support and to education as though born in lawful wedlock. An illegitimate child born in a maternity hospital is given the surname of the father if known. The North Dakota law does not, however, provide means for overcoming some disadvantages from which children born out of wedlock suffer and which the law declares are abolished. In regional conferences with reference to the problems of illegitimacy, held under the auspices of the U.S. Children's Bureau, agreed upon principles with reference to the illegitimacy problem which should be recommended to legislatures; in Aug. 1920, the National Conference of Commissioners on Uniform State Laws appointed a committee to consider legislation in this field and to prepare a model law which might be adapted by the various states to local conditions. The ground was thus well prepared for legislation.

**Dependent Children.**—Massachusetts did the first important work in boarding the state's dependent children in family homes instead of in institutions for children. Since the White House Conference on the Care of Dependent Children in 1909 there has been a growing recognition by both private and public agencies of the importance of providing, for children who must be removed from their own homes, home life as nearly normal as possible.

Although there had been an increase in institutional provision for the feeble-minded, facilities for the custody and training of the subnormal were in 1920 still inadequate in all states. A special commission in Massachusetts relative to the control, custody and treatment of defective criminals and misdemeanors reported to the Legislature in 1919. As a result of its recommendations laws were passed in Massachusetts providing for a census of retarded school-children, the establishment of special classes in the public schools for such children, and the registration of the feeble-minded by a Commission on Mental Diseases. By 1921 similar legislation had been adopted or was under consideration in a number of states.

**Juvenile Courts.**—Since the first fundamental modification of court procedure relating to children was made in Illinois in 1899, every state, except Connecticut, Maine and Wyoming, has adopted so-called "juvenile-court" laws. This legislation has been fitted into the local judicial systems, so that there are many differences not only between states but in different parts of the same state. A questionnaire study of the courts in the United States hearing children's cases, made by the U.S. Children's Bureau for the year 1918, showed 2,391 courts organized under these statutes; 1,269 of them reported a total of 140,252 cases heard during the year, including 79,946 cases of juvenile delinquency heard in 1,088 of these courts; 37,877 cases of neglect and dependency were reported by 791 courts. From the replies received, the Bureau estimated that the number of children's cases heard annually in the juvenile courts of the United States approximates 175,000. The constitutionality of laws creating juvenile courts and certain general principles on which they must operate have been generally established; separate hearings, informal or chancery procedure, professional probation officers for investigation and supervisory care, detention of children separate from adults, and a system of recording and filing the social as well as the legal history of each case are now recognized as necessary. During the years 1910-20 attention was centred on the working-out of these principles in actual practice. As a result there was an extension and improvement of the probation service (every state except Wyoming had in 1921 legislative provision for juvenile probation); better methods were developed for gathering and recording social as well as legal facts, and cooperation with other agencies was increasingly effective. The practice in many places still fell far short, however, of the idea.

**Miscellaneous.**—Certain significant tendencies of the decade 1910-20 may be noted.

(1) Provision for "mothers'" or "widows'" pensions or "funds for parents," in order that dependent children may be cared for in their own homes.—The first two laws of this type were adopted almost simultaneously in Illinois and Missouri in 1911. In Illinois the legislation was sought by Judge Merritt W. Pinckney, of the Juvenile Court of Cook County (Chicago). He was moved to do this by the large number of children for whom dependency petitions were filed solely because, in his opinion, their fathers were dead or incapacitated. In 1920, 40 states and the territories of Alaska and Hawaii had passed what came to be known generally as "mothers' pension" laws. Such opposition as there was to these laws came from private relief agencies which believed, because of the general failure of public outdoor relief, that the laws would never be well administered by a public agency. In 18 states, among them Colorado, Illinois, Minnesota, Ohio and Wisconsin, the administration of these laws was lodged in the juvenile courts and has involved a great increase in the work of those courts. Contrary to the fears of many, the standard of work done in the administration of the mothers' pension laws by the Chicago and other courts was generally equal to that of the better private agencies in the same communities.

(2) Provision for medical and psychological examinations.—The recognition of the physical condition of the child as a factor in delinquency came first. In 1921 23 courts, all but three in large

cities, had physicians regularly attached to the courts, while 658 courts had either private practitioners or city or county health officers make physical examinations of the children brought before the juvenile courts. The Juvenile Psychopathic Institute, with Dr. William Healy in charge, began in 1909 under private auspices the study of mental causes of delinquency in the Chicago Juvenile Court. The judge was soon convinced of the importance of having before him the information supplied by psychopathic examination of the children. His and Dr. Healy's clinic was therefore taken over by the court. Mrs. and Dr. Healy's clinic became a part of the court organization in 13 courts; in some the mental examinations being made only in specially difficult cases, or of children suspected of being subnormal. In Boston the Judge Baker Foundation, cooperating with the juvenile court, was (1921) attempting to make a complete physical, mental and social diagnosis of the condition of most of the children who came before the court. The diagnosis was agreed upon and treatment recommended to the judge by the director of the Foundation after a staff conference.

(3) Enlarging the jurisdiction of the court.—The first movement in this direction was to expand the definition of what constituted a delinquent, neglected, or dependent child, so that the court should in no case be prevented, by the lack of technical jurisdiction, from assuming the care of a child. Mothers' pensions have already been referred to. Children's agencies were in 1921 advocating that juvenile courts should be given the trial of adults charged with contributing to the delinquency or dependency of children, of crimes against children, of bastardy actions, and, less generally, of cases of desertion and non-support. The minimum standards of child welfare adopted by the Washington and Regional Child Welfare Conferences called by the U.S. Children's Bureau in 1919, recommended that the jurisdiction of the juvenile courts should in all cases be extended to deal with adult sex offenders against children, so that the children may be protected against unnecessary publicity and further corruption in the course of the trial. The question of combining and coordinating the functions of the juvenile courts and the domestic relations courts which have been organized in many places was discussed by probation officers' associations and social workers generally. There was general agreement that the juvenile-court method of investigating, of giving weight to social history and special consideration to the welfare of the children concerned, is needed in the handling of the family problems which come before the courts in connection with desertion, divorce and illegitimacy. There was no such general agreement as to whether these problems should be taken over by the juvenile court or by a family court.

(4) Curtailment of the jurisdiction of the juvenile courts.—Along with the movement to increase the jurisdiction of the court there has been a movement in the opposite direction. Early enthusiasm for the courts has given place to a more critical attitude, and it is now very frequently held that functions have been given the court that could be better performed by other agencies. Child placing and the whole problem of dependency and mothers' pensions are cited as administrative burdens that should not be placed on the courts. Massachusetts, the state in which the probation idea was first developed, does not use its court machinery for either of these tasks, but assigns them to public charitable agencies; in some states, Minnesota being perhaps the best example, elaborate administrative agencies have been developed in cooperation with the courts. School machinery that would make resort to the courts in the truancy cases either unnecessary or less frequent is also advocated.

(5) The appointment of a specially qualified woman to act as referee to hear the cases of delinquent girls and to make recommendations to the judge as to the disposition of the cases is believed to be a forward step. Many states require that a woman, usually a probation officer, must be present at the hearing of delinquent girls. Chicago, Cincinnati, Cleveland, Denver, Los Angeles and Philadelphia have women referees who regularly hear the girls' cases. In D. C. the judge of the juvenile court is a woman.

(6) Extreme decentralization in administrative authority in the various states is responsible for the great diversity often found in the same state under the same law. There is an effort to establish at least minimum administrative standards by increased state supervision or control in connexion with many types of social legislation. Recent investigation has shown it is sorely needed in the juvenile court field, and standardization is being attempted through the probation service. New York and Massachusetts both have had for some time state probation commissions, which exercise general supervision over probation officers. Recent legislation in Alabama and North Carolina goes further in this respect.

**BIBLIOGRAPHY.**—For further information see reports of the U.S. Children's Bureau as follows: S. P. Breckinridge and Helen R. Jeter, *A Summary of Juvenile-Court Legislation* (Legal Series, No. 5, 1920); Helen R. Jeter, *The Chicago Juvenile Court* (in press); Evelyn Belden, *Courts in the United States hearing Children's Cases* (Dependent, Defective and Delinquent Classes Series, No. 8, 1920); Laura A. Thompson, *Laws Relating to Mothers' Pensions* (Legal Series, No. 4, 1920); S. P. Breckinridge and Edith Abbott, *Administration of Aid-to-Mothers' Law in Illinois* (in press); Emma O. Lundberg and Katherine F. Lenrot, *Illegitimacy as a Child-*



*Welfare Problem* (Dependent, Defective and Delinquent Classes Series, No. 9, 1920); Ernst Freund, *Illegitimacy Laws of the United States* (Legal Series, No. 2, 1919). See also S. P. Breckinridge and Edith Abbott, *The Delinquent Child and the Home* (New York: Charities Publication Committee, 1912); Bernard Flexner and Roger N. Baldwin, *Juvenile Courts and Probation* (1914); William Healy, *Individual Delinquent* (1915); *Mental Conflicts and Misconduct* (1917); *Honesty: a Study of the Causes and Treatment of Dishonesty among Children* (1915); *Annual Reports and Proceedings of the National Probation Association; Annual Reports of Massachusetts Commission on Probation; Reports of New York (State) Probation Commission; Proceedings of National Conference of Social Work, Section on Children.* (G. AB.)

**CHILD WELFARE.**—During 1905-21 the question of Child Welfare became one of continually increasing interest to social reformers.

Before that, the interest in it was mainly from the philanthropic point of view, but the steady decline of the birth-rate in the United Kingdom made it a pressing necessity to endeavour to preserve the vitality of the nation. Though it is true that the efforts to preserve infant life have been in great measure successful, this has not made up, from a population point of view, for the reduction in the number of infants brought into the world; but the most strenuous and successful efforts are being made to minimize the evil. France was in even a more serious condition as regards reduction of population than England and she very early directed her energies towards the encouraging of breast-feeding and the supply of institutions for the supply of good milk known as *gouttes de lait*, a plan which for a time was followed in the United Kingdom. It was about the year 1905, however, that the system which obtains of home visitation, combined with centres for teaching and helping mothers, began to take firm root in England, and, like so many other agencies for social amelioration, it began through voluntary agencies, in which experiments of various kinds could be freely tried. It is to their credit that the work of assisting the mother and child has been developed as it has, and it is on the lines that they started that the work has been followed up. Hampstead, Westminster and other London boroughs set to work in these early days and the records then begun are now proving most useful with the next generation.

**Registration of Births.**—The necessity for work of this kind depends largely on the keeping of accurate registers, and on their availability. It is only in Great Britain, Germany and France, of European countries, that records of a satisfactory kind can be had. Up to 1837 there were registers of baptisms obtained from churches and chapels, but they were far from complete. After this date registration by the parent was made compulsory within 42 days from birth. This, however, was not sufficient for early visitation of infants and their mother, even could permission to use the registers be obtained. In 1906 Huddersfield obtained parliamentary powers for the compulsory notification of birth to the Medical Officer of Health, and in 1907 a Notification of Births Act was passed which permitted local authorities to adopt a system of compulsory notification, subject to the consent of the Local Government Board. This was given when it was ascertained that the adoption of the Act would be followed by the utilization of the information given by a system of home visitation. When adopted, the birth had to be notified within 36 hours to the Medical Officer of Health for the district. This Act was largely adopted, and it was made to extend to the whole population in 1915 by the Notification of Births Extension Act. This Act took the important step of giving definite power to local authorities of levying rates for infant welfare work. Before it became law, although Exchequer grants became available, many authorities were unwilling to incur expenditure; much voluntary work was, however, being carried on, births being discovered through the lying-in and other hospitals as well as through district visiting. In 1921 home visitation was largely done by the local authorities, more especially in the provinces. In spite of all that was done beforehand, however, notification has been the key to all welfare work, and it is the carrying of it out in respect both of births and infectious diseases that has allowed such work to develop. The World War proved a great

incentive to this work by bringing home to Great Britain the need for the preservation of the young population.

**Infant Welfare Centres.**—The first task has been to coördinate the work at the Infant Centre and the visitation of the mothers in their own homes. The former were often termed "Schools for Mothers," since they specialized in teaching the mothers what was considered necessary for good motherhood. It was soon found that medical advice was required in addition to the usual classes for cookery, garment-making, etc., and that infant consultations were of little use without helping the mothers to carry out the advice given in their own homes. The medical inspection of school-children showed how essential it was that the alarming conditions that were discovered in children of school age should be dealt with before the child came to school, and, indeed, that it was necessary to go back to ante-natal conditions. Some of the advanced health centres had already realized this fact and were carrying on that work. It was brought home to those interested that the work required was preventive far more than curative, and that the whole social condition of the family was involved—the health and habits of the parents, sanitation, and general surroundings. Above all the housing question was, it was felt, intimately bound up with this question. The task was now to link up, so far as might be, the various ameliorative efforts that were being made with the end of bettering the chances for the infant, as well as the agencies for invalid aid, country holidays and so on for the child. It is certainly true that curative work is required as well, but the child welfare movement primarily aims at bringing into the world a healthy population and endeavouring to preserve for it healthy and natural conditions. At the same time it must be in touch with hospitals and other directly curative agencies.

Though every birth may be notified to the Medical Officer of Health, some (about 20%) are not as a rule visited. Visits are usually made about 14 days after birth, since before that time the mother is being attended by a midwife or doctor. A record card is presented in each case, and this has to be carefully filled in. This card is preserved and kept up to date till the child goes to school, when the information it contains is invaluable to the school medical officer.

The "Centre" varies in size from two rooms to many. There are now many large buildings devoted to the work, in which there are not only the waiting rooms and doctor's rooms of the old days, but also a weighing room, toddlers' room, where the older children are looked after while the mother is engaged at classes or otherwise, perambulator shed, and an open-air shed where the children can sleep. Then at a large centre there is a dental room, a pre-natal consulting room, and frequently observation wards, where sickly children can be kept for a time under notice. This involves nurses and servants' accommodation. Sometimes there is also accommodation for mothers. Then a day is often given up for the medical examination of older children under school age. Thus a large centre has become a varied conglomeration of activities, and it probably has small branch centres dependent on it, so that no mother may have more than a short distance (say a mile) to walk. Much stress is laid on the matter of clothing, and every effort is made to obtain the best patterns for the clothing of both infants and mothers and older children and then to get the mothers taught to use them. A system of card-indexing for record is adopted, so that all information is easily available. For the classes (cookery, mending, cutting-out, etc.) a trained teacher is often, and in the large centres usually, employed. In addition, lectures on health matters are given to the mothers as well as to voluntary or other social workers. Ante-natal work brings the welfare work into touch with the work of doctors and midwives (see NURSING), and though in some cases it leads to midwives being appointed for the work of the centre, the usual plan is simply to see that the woman in some manner secures adequate and suitable provision for her confinement. If a medical examination is required by a midwife for her patient, although the power to pay doctors' fees was conferred by the Maternity and Child Welfare Act of 1918, the arrangements for providing it are very limited, and the woman therefore often prefers to take advantage of the opportunities offered at the Child Welfare Centre. At these centres nursing mothers are sometimes provided with dinners, though there is a difference of opinion as to the desirability of doing this. Under the Act just quoted these dinners may be paid for from the rates. The provision of milk has also been frequently carried out. The first form of milk used was that which is known as "pasteurized," and it was followed by dried milk, which is often bought wholesale and sold at cost price. The question of how far milk depots are desirable, and

whether they discourage breast-feeding, is still being discussed. The shortage of milk during the World War and its high price made the question acute.

The maternal and infant centre is in some cases provided with a garden where the mothers can sit with their little ones, or where infants may be left to sleep under guardianship while the mother is indoors. Occasionally a play centre for young children is combined with an infant centre. These play centres are instituted in crowded districts for the use of young children. Though they may be acquired and supported by the local authority they are sometimes given by private donors and occasionally equipped by them or by bodies like the Carnegie U. K. Trust. The movement was naturally retarded by the World War and its after effects. In play centres provision is usually made for toddlers, children below five years of age and also separately for older children who can play organized games. A portion of the ground is often covered with asphalt for use in bad weather and a pavilion is provided for storing apparatus and for shelter. There must of course be adequate supervision and possibly an expert instructor. The nature of these developments depends on the size of the ground available and the amount of money that can be spent on it.

The limitation of the legitimate activities of the infant centre has never been defined. Thus, not only does the relationship of the pre-natal work with that of the ordinary midwife come to be a somewhat difficult one, but there arises the further question of what amount of treatment and drugs should be given. In any case it seems clear that it would be wholly unsuitable to convert an infant centre into anything of the nature of a small and expensively run hospital.<sup>1</sup> At the same time there is frequently difficulty in obtaining the hospital treatment suitable for infants and very young children, and certainly no opportunity is given for teaching the mother how to carry on that treatment at home. It has been matter of complaint that the health of children between two and five (school age) has not been cared for sufficiently owing to the dual authority (Public Health Department and Education Authority) which respectively controlled infant welfare and school-children. But under the Ministry of Health the case may be different.

**Health Visiting.**—The number of visits paid to a mother by a health visitor naturally varies, but about 400 cases are allowed to one visitor, though of course it may be that the visitor is called upon to visit children up to school age, when not nearly so many could be allowed. The visitor is called on to visit all homes where still-births are reported, and it is necessary to report all births taking place after the twenty-eighth week of pregnancy. A certain amount of ante-natal visiting may also be done if the visitor has midwifery qualifications, but this might be regarded as interfering with the work of the midwife or doctor engaged by the mother.

**Organisation of Child Welfare Work.**—The movement has made rapid progress. It was estimated that in 1921, there were in England and Wales 1,754 infant centres, mostly in the hands of municipalities or county councils, though 693 were worked by voluntary agencies.<sup>2</sup> The municipal centres are carried on by the Public Health Committee under the local authority. The county, city or borough council elects its Committee for Public Health, and in 1918, under the Maternity and Child Welfare Act, a statutory committee was made necessary for the purpose of carrying out its requirements, the majority of whose members must be members of the council. Before the 1918 Act these duties fell on the Public Health Committee, though sometimes it devolved them on a sub-committee which might become the statutory Welfare Committee. At least two members of this committee must be women and it has to report to the Public Health Committee. In counties this Welfare Committee is usually a separate one, and is granted considerable power. The staff of visitors work as part of the staff of the department of the Medical Officer of Health. In the towns the visitors endeavour to get the mothers to bring their infants to the centres and in some places half of those visited do so. Of course, not all these children necessarily go before the doctor on each occasion. There are many variations in the manner of working the centre, depending on the nature of the area. In the country the visitors usually undertake the threefold duties of infant, school and tuberculosis visiting. The visitors are usually stationed in small towns or villages within the area and visit around these. "Centres" may or may not be established in these towns or villages. In most countries there are nursing associations for the supply of parish nurse and medicines, and the Education Committee often helps in the training of the nurse. These nurses are sometimes employed as visitors for infant welfare work as well as for school work and occasionally for tuberculosis and

are subsidized for such visiting through the association. Of course they must be under the Medical Officer of Health in respect of such work. The superintendent of the county nursing association may also be appointed inspector of midwives for the county. Usually whole-time visitors are employed in the larger towns. It is thought by some that the whole nursing service should be placed under the councils and the voluntary element done away with; others are strongly opposed to such a policy as tending to bureaucracy.

**Work of Education Authorities.**—It is difficult to consider infant welfare work in Great Britain without taking into consideration also the work of Education Authorities to whom power was granted to carry on the work of medical inspection in 1908. As with infant consultations it was soon found that following up the cases in their own homes was essential if good was to be done, and very often the infant visitor carries out the visiting for both infants and school-children. The Mental Deficiency Act of 1913 also requires county and borough councils to do work which requires visitation. Unless care is taken there is serious danger of overlapping.

**Training of Visitors.**—The training of infant visitors cannot as yet be said to be standardized. The training of a nurse is useful, but hospital experience alone is not sufficient, any more than is that of midwifery or the sanitary diploma. The Board of Education has now issued a regulation for the training of health visitors which is fairly complete, and includes theoretic training in physiology, hygiene, and social work, as well as practical training in cookery and housewifery, and much work of various kinds at health centres. Voluntary workers with social knowledge and wide experience are of great use. There were in 1920 3,359 health centres in England and Wales, and probably many more will be required.

**Day Nurseries and Crèches.**—In addition to the recognized infant welfare work, there are numerous day nurseries and crèches which are eligible to receive Government aid. The mothers contribute a proportion of the cost. Nursery schools receive grants from the Board of Education under the Act of 1918 and crèches come under the Ministry of Health. Children up to school age are taken by the former and infants by the latter. During the World War, when married women were working, these institutions were invaluable and, if well conducted, day nurseries form an excellent training ground for young women and girls. An endeavour has been made to obtain a service of "home helps" of a domestic sort to provide assistance for the mother before and after childbirth, but it has been found difficult to obtain candidates for training.

**Infant Mortality.**—It appears that the association of a high birth-rate with a high infant mortality is a rule to which exceptions are rare. Thus it is the high birth-rate, despite its accompanying waste, rather than the low birth-rate and the greater saving of life that accompanies it, that dominates the increase of population. There is no doubt that the efforts made to preserve infant life have been a very effectual method of preserving the population, but this has not made up for the reduced number of babies born. The chief cause of the deaths of infants are (1) developmental, wasting diseases and convulsions; (2) diarrhoea and enteritis; (3) measles and whooping-cough, bronchitis and pneumonia. One-third of the deaths during the first year occur during the first months of life. What is called the "infant mortality-rate" is the number of infants dying under one year of age per 1,000 infants born. The following table shows the infant mortality-rate for England and Wales and the birth-rate for the corresponding year.

Year	Infant Mortality-rate (per 1,000 births)	Birth-rate (per 1,000 of pop.)
1901-5	138	28.2
1906-10	117	26.3
1913	108	26.0
1916	91	20.9
1917	97	17.8
1918	96	17.7
1919	89	18.5
1920	80	25.4

This shows that the birth-rate has tended to fall as well as the infant mortality-rate, but the fall of the latter is remarkable and may be ascribed partly to the improved social conditions during and since the war, and partly to the definite work for child welfare, as well as to the decrease in the number of births. Where there is overcrowding and bad sanitary conditions child welfare work seems to do little to prevent infant mortality. The rate of mortality amongst illegitimate children is approximately twice as great as that amongst legitimate infants. The Ministry of Health has approved a number of Homes for single women before and after confinement as well as hostels where the mothers and children can live when the mother is able to take up daily work. The highest mortality amongst infants in England and Wales is found in the northern county boroughs which include the great industrial centres, and the least in the southern rural areas. It is to be hoped that with good midwifery and ante-natal service and better social conditions, the large infant mortality that now exists may be decreased, for it is clear that the health of the mother and child is the first step towards the health of the community. The Midwives Act of 1902 and the provisions for maternity benefit in the Insurance

<sup>1</sup> During 1920 fifty new maternity homes with over 500 beds were provided by local authorities and voluntary agencies in England and Wales.

<sup>2</sup> On June 1 1921 there were 1,780 infant welfare centres in England alone, 710 of which were voluntary.

Act of 1911 have no doubt been contributory measures to the improvement in this matter, as well as the School Medical Service that was organized in 1907, and the Maternity and Child Welfare Act of 1918. The death-rate of women in childbirth, however, has remained about the same during the last 25 years, and there is a large amount of abortion, miscarriage, etc., and many children are disabled when born and become chronic invalids. The maternity mortality-rate from all causes remains between 4 and 5 per 1,000 births. The steps necessary to be taken are to secure (1) the supervision of pregnancy and the wise administration of maternity benefit; (2) the supervision of midwifery, including the establishment of maternity homes; (3) health visiting and nursing and (4) the establishment of infant welfare centres. In this work voluntary assistance is most desirable.

A very important fact is that by the Ministry of Health as of 1919 the physical care of maternity, infancy and childhood is now under one state department and the work of the Education Authority is coördinated so far as possible with that of the Sanitary Authority which primarily deals with the child to its fifth year. The same centres and clinics are now used for both. There is a special department of the Ministry for supervising this work. A scheme of maternity and child welfare has been inaugurated in every county (excepting one county in Wales), and in every county borough and many of the large urban districts. On March 31 1920 not only were there 1,754 maternity and infancy welfare centres and 3,359 visitors as stated before, but also 221 day nurseries or crèches, and 89 maternity homes with 1,360 beds.

The hospital provision for infants is not (1921) large, and there is often a high mortality found in hospitals owing to the spread of infectious conditions which are rather obscure. About 220 new beds have been provided for infants and young children in connexion with welfare schemes. In cases where young children must be separated from their mothers a good foster-mother sufficiently remunerated is recommended as being the most satisfactory guardian.

**Scotland.**—The Maternity and Child Welfare Act of 1918 does not apply to Scotland, but in the Notification of Births (Extension) Act of 1915 it is provided that any local authority "may make such arrangements as they think fit, and as may be sanctioned by the Local Government Board for Scotland, for attending to the health of expectant mothers and nursing mothers and of children under five years of age within the meaning of Sect. 7 of the Education (Scotland) Act 1908."

As in England, Exchequer grants-in-aid are given for certain services in connexion with child welfare, and the extent to which these services extend depends on the local authority concerned. There is, however, an important difference between England and Scotland. In England certain institutions such as schools for mothers and play centres receive grants direct from the Board of Education and are under its control. In Scotland all the institutions included in a child welfare scheme were controlled by the Local Government Board and are now controlled by the Ministry of Health. In Scotland, also, the grants are only made to the local authorities and not, as in England, to the institution. These grants cannot exceed 50% of the local authority's approved outlay. The schemes that are carried on are similar in character to those in England. The infant mortality (deaths of children under one year old per 1,000 births registered) is considerably higher than in England and Wales and Ireland though it is gradually decreasing. In 1917 it was 107; in 1918, 100; in 1919, 102; and in 1920 it was 92.

Since the coming into operation of the Scottish Education Act of 1918 there has been a considerable accession of energy in the matter of attending to the health of school-children, and that Act gives powers to the Education Authority to carry on nursery schools. Education Authorities often take advantage of the services of district nurses in following up their cases in the rural areas, and this is sometimes also done by the county council in regard to its schemes for infant welfare. In such cases the nurses may work through a County Nursing Federation. The Highland districts naturally present special difficulties owing to the scattered nature of the population and the difficulty of providing adequate attendance.

**Ireland.**—A system of Imperial grant for child welfare obtains in Ireland similar to that in England. The infant mortality in Ireland has always been low as compared with that in England and Wales and still more with that of Scotland, but it has not declined in the same regular manner that it has done in the other countries. The deaths of infants under one year per 1,000 births in the years 1891-1900 averaged 104. In 1918 they were 86, and in 1919, 88. It is notable that the infant mortality in the towns in Ireland is immensely higher than in the rural districts. In 1919 the infant mortality in Dublin area was 141 per 1,000 births, while in London it was 85. Notification of births was made compulsory in all urban districts by the Extension Act of 1915.

There are many voluntary societies, such as the Women's National Health Association and the United Irishwomen, working in connexion with infant welfare, and in establishing milk depots, etc., and since the Treasury grant became available a number of authorities have submitted schemes of a comprehensive character.

See *Annual Report of the Chief Medical Officer 1919-1920* (Ministry of Health); *First Annual Report of the Scottish Board of Health*

1919 (Appendix to ditto pub. 1920); *Twenty-fifth Final Annual Report of the Local Government Board for Scotland 1919* (pub. 1920); *Annual Report of the Local Government Board for Ireland 1918-1919*; Janet E. Lane-Clayton, *The Child Welfare Movement* (1920); Nora Milnes, "Child Welfare" from the *Social Point of View* (1920); Edith V. Eckhard, "The Mother and the Infant" (Social Science Library 1921); *Carnegie United Kingdom Trust's Report on "The Physical Welfare of Mothers and Children"* for (1) England and Wales, E. W. Hope; (2) Scotland, W. Leslie Mackenzie; (3) Ireland, E. Coey Bigger (1917). Sir J. E. Gorst, *The Children of the Nation and how their Health and Vigour should be Promoted by the State* (1906); Margaret Macmillan, *Early Childhood* (1900), *The Nursery School* (1919). (E. S. H.)

#### UNITED STATES

In the field of child welfare considerable progress was made in the United States during the decade 1910-20. The first work of the Federal Children's Bureau (established 1912) was a number of remarkable studies on infant mortality, particularly its social and economic aspects. As a result of emphasis by the American Medical Association, by the Children's Bureau and by other children's agencies of the necessity of basing any programme for reducing the infant mortality upon reliable statistics, all but three of the states had adopted in 1922 the uniform registration plan recommended by the Census Bureau, and all but five states now have good registration laws.

Popular education in child care has been greatly developed in the last decade. Aided by the Children's Bureau, Baby Week Campaigns were inaugurated in a few large cities in 1914. In 1916 the General Federation of Women's Clubs and the Children's Bureau cooperated in a nation-wide "Baby Week" campaign, as a result of which Baby Week was observed in every state. In 1918 the Bureau and the Child Conservation Section of the Women's Committee of the Council of National Defense cooperated in a year's educational propaganda known as "Children's Year." As a result of the interest awakened through these campaigns as well as by the previous efforts of many child welfare organizations, child hygiene divisions were established by law in 30 states from 1918 to 1921, as compared with eight states between 1912 and 1918. There were also in 1921, special child hygiene divisions in the health departments of 45 municipalities. The Children's Bureau report on maternal mortality in 1917, followed in 1919 by one on maternity benefit systems in certain foreign countries, resulted in a general demand by women's organizations for public provision for the protection of maternity.

Prior to 1910 pre-natal care for mothers was confined to maternity hospitals. During the decade 1910-20 there were demonstrations in Boston, New York, and a number of other cities of the reductions that can be effected in maternal mortality and in infant mortality due to maternal causes, through maternity centres, where pre-natal and post-natal instruction and care have been given. As a result of the wide-spread interest in the subject, bills have been introduced in a number of the state legislatures; and the Sheppard-Towner bill, providing for Federal aid toward public provision for maternity and child care, was passed by the U.S. Senate in 1921. Medical inspection of school-children was in 1921 required by law in 39 states, and the first legislation had been passed making specific provision for dental inspection. Without this specific legislation increased attention has been given to the care of school-children's teeth in recent years. Nutrition clinics for undernourished children have been widely established during the past five years in connexion with schools, dispensaries, and child welfare agencies. Since 1915 eight states, including Illinois and New York, have passed laws providing for physical education in elementary schools.

REFERENCES.—*Infant Mortality Series*, Nos. 1 to 8; Grace L. Meigs, *Maternity Mortality* (Miscellaneous Series, No. 6, 1917). (G. Ab.)

**CHILE** (see 6.142).—The term of office of President Don Pedro Montt, inaugurated in Sept. 1906 to serve for a term of five years, was terminated by his death abroad on Aug. 16 1910. Sr. Don Elias Fernandez Albano, the Minister of the Interior, succeeded under the title of vice-president,

as provided in the constitution, article 65. Before a new election for the president could be held, in accordance with the requirements of the constitution, Sr. Albano died on Sept. 6 and was succeeded by Sr. Don Emiliano Figueroa, Minister of Justice, who held office until Dec. 23, the date of the inauguration of Dr. Ramón Barros Luco, the new president elected Nov. 15. Dr. Luco had had a long career of public service starting as a Liberal deputy, and serving as Minister of Finance under President Federico Errazuriz and President Domingo Santa María, as Minister of the Interior and premier under Presidents Balmaceda and Jorge Montt, and later premier for several terms. His election, therefore, marked the triumph of the Liberal over the Conservative and Clerical party. In 1910 several other events of general significance occurred. One was the opening of railroad traffic through the Transandine tunnel, connecting Buenos Aires with Santiago and Valparaiso. The piercing of the tunnel occurred late in 1909 and the first trains were run through in 1910, thus completing a remarkable feat of railway engineering and realizing a dream of many decades. Another important event was the celebration of the centennial of Chilean independence, lasting throughout the month of Sept. but concentrating chiefly on the 18th, the centenary of the transference of governmental power from the Spanish governor to the locally elected *junta*. Aside from its effects in stimulating patriotism and national pride, the celebration was made the occasion for accorded special honours and attention to the Argentine nation and its representatives; this strengthened still further the rapprochement between the two nations which dated from the settlement of their long-standing boundary dispute in 1902. In 1911 the Chilean Government paid 2,975,375 bolivianos in settlement of the long-standing Alosop claim, in accordance with the award of King George V., of England. This marked the termination of a dispute which had for years been one cause of bad feeling between the Governments of Chile and of the United States. In 1913 there was completed and put into operation the railway between Arica, a seaport in the provinces secured by Chile from Peru in consequence of the war of the Pacific, and La Paz, the principal city of Bolivia. This line, which has a total length of 264 m., was built by the Government of Chile with the coöperation of Bolivia; until 1928 the control of the entire line was to remain with Chile, after which date Bolivia was to have control of the portion within her territories, under conditions stipulated in the treaty of 1905. The provisions of this treaty with reference to this railway and free access to the sea for Bolivia were among the factors that led to further attempts to settle the long-standing controversy between Chile and Peru with regard to the provinces of Tacna and Arica, especially in the years 1905 and 1908 (see TACNA-ARICA). In 1913, the two countries, unable to come to any agreement, decided to postpone the settlement of this question for another 20 years. It was, however, reopened, as will appear later.

At the outbreak of the World War a considerable section of opinion in Chile was inclined to be favourable to Germany. A number of factors contributed toward making this situation a natural one. The Chilean army had long been trained by Prussian officers and modeled on Prussian lines. German scholars held important positions in the institutions of higher learning in Chile, and many native teachers had completed their education in German universities. A considerable homogeneous and thrifty German population, moreover, was concentrated in the southern portion of the country and a well directed propaganda system kept the German point of view before the nation. The clergy, also, were in large part favourable to the cause of Germany against a nation like France which had in recent years adopted such a radical anti-clerical policy. Finally, there was the commercial factor, for in 1914 Germany headed the list of nations in the value of goods shipped to Chile and ranked third in the value of the Chilean goods imported. With this commerce, totalling in that year, in spite of the outbreak of the war, some \$44,000,000, or considerably more than a fifth of the total foreign commerce of Chile, was combined a quasi-political propaganda

which had not been matched in any way by the other European nations.

The sinking of the German cruiser "Dresden" by British warships in the territorial waters of Chile, which had to be admitted by the British Foreign Office to be irregular, caused a protest, but the incident was adroitly handled in London by the Chilean minister, Augustin Edwards, who, throughout the war, was a friend of the Allies. The reduction of the foreign commerce of Chile by the blockade caused serious economic disturbances almost at the very outset of the war, and especially in 1915. A gradual change in the popular attitude in Chile began to make itself felt, however, in the last two years of the war, although Chile, having virtually no ships engaged in European trade, did not come into immediate conflict with the German submarine policy as did some of the other Latin-American states. Officially Chile maintained a position of strict neutrality, though protesting emphatically against the announcement of German unrestricted submarine warfare, on Feb. 8 1917. Upon the declaration of war by the United States in April 1917, Chile again made a declaration of neutrality.

Meanwhile, in 1915 Sr. Juan Luis Sanfuentes, the candidate of the Liberal Democrats or new Balmacedists, succeeded to the office of president for a five-year term beginning Dec. 23. The political campaign was marked by great excitement and some disorder, including the assassination of one of the deputies. The victory in the election was due to a coalition of the Liberal Democrats with the Conservatives and Nationalists, as against a combination of Radicals, Liberals and Democrats.

The law for the conversion of the currency which was to have gone into effect in 1915 was again postponed for a period of two years. The financial and industrial situation of the country was extremely grave in 1915. Some relief was experienced from the sale of the battleships in construction in British yards which were requisitioned for war purposes by the British Government. The year 1916 saw improvement in the commercial situation as shown by an increase of about \$25,000,000 in the value of imports and of nearly \$68,000,000 in the value of exports, due chiefly to the allied demand for materials used in the manufacture of munitions. This was the highest figure ever reached up to that time in the export trade of Chile, but it was greatly exceeded the next year and even more in 1918, when the total value of the exports was more than double the value reached in any year prior to 1916.

The year 1917 saw still further improvement in financial and business conditions, though the conversion law was again postponed for a two-year period. The year was again marked by the instability of cabinets which has been so characteristic of the governmental history of Chile. An agreement was reached for the resumption of friendly relations with Peru which had been interrupted in 1910, as on other numerous occasions, over controversies growing out of the old-standing Tacna-Arica dispute. The year 1918 was marked by renewed difficulties with Peru in consequence of anti-Peruvian riots at Iquique and Antofagasta, culminating in the mutual withdrawal of consular agents from both countries. Cabinet resignations were again numerous, a coalition cabinet in April being organized under Arturo Alessandri who was elected two years later to the presidency of the republic. In 1919 the Tacna-Arica controversy again threatened to disrupt the peace of South America. The publication of the secret treaty of 1904 between Chile and Bolivia with reference to the disputed provinces and an outlet to the sea for Bolivia, combined with disturbances involving Peruvians in those areas, aroused animosities anew. In the same year Chile concluded a treaty with Great Britain providing for a permanent peace commission to settle such disputes between the two countries as could not be adjusted through diplomatic channels.

Chile suffered severely from after-the-war readjustment, involving there, as in other countries, labour troubles and radical demonstrations. The year 1920 was marked by one of the most interesting and in some respects the most significant of all the presidential elections of Chile. The contest was be-

tween Sr. Arturo Alessandri, the candidate of the so-called Liberal Alliance, comprising the Radical and Democratic parties and a portion of the Liberals, and Sr. Luis Barros-Borgono, the candidate of the so-called National Union, made up partly of Liberals and largely of Conservatives. Sr. Alessandri was distinctly the exponent of the labour and middle classes. Sr. Barros-Borgono belonged, as had virtually all former presidents of Chile, to the dominant political aristocracy, comprising the long-established families closely affiliated with the landowners and the clergy. The election was held June 25 and the announced electoral vote was 179 for Sr. Alessandri, and 175 for Sr. Barros-Borgono. Under the constitution of Chile, as in the case of the United States, the electoral vote for president is to be canvassed by both Houses of Congress sitting jointly, and in case no candidate receives an absolute majority the power of election rests with Congress. Now with the electoral vote so close and the validity of various electoral votes questioned, a situation arose almost identical with that which occurred in the United States in the famous Hayes-Tilden contest in 1877. The Senate was openly in favour of the candidacy of Sr. Barros-Borgono, and public opinion, which had been raised to the highest pitch, demanded that the counting of the electoral vote should be delayed until the matter could be passed upon by a special court of honour, a proposal put forth by Sr. Suarez-Mujica, a former minister of Chile to the United States. Here again was a reproduction of the extra-legal election commission in the settlement of the Hayes-Tilden dispute. This court of honour, after a strenuous period of activity, finally decided on Oct. 4 in favour of Sr. Alessandri by a vote of five to two, as having received a majority of one electoral vote, 177 valid votes against 176. Congress accepted this finding two days later and declared Sr. Alessandri elected. For a brief period popular excitement ran at fever heat and a general strike was even instituted. The election was remarkable, alike in the manner of its final settlement and in the character of the man elected to the chief magistracy. It was remarkable also, because of the general participation of the labour and middle-class elements and a relatively greater freedom from the practice of buying votes than had ever been experienced before. It was looked upon, therefore, as a distinct triumph of democratic principles.

One further development at the close of this period is worthy of mention, namely, the relation of Chile to the League of Nations. Chile, not being a belligerent in the World War and having adhered to her policy of neutrality, was of course not represented at the peace table. Nor was she, for the same reason, among the original members of the League. She was, however, among those specifically invited by the Covenant to accede thereto, and in his message of June 1919 President Sanfuentes approved the League. This suggestion prevailed, and Chile joined the membership of the League Nov. 4 1919. She was represented at the first meeting of the assembly of the League of Nations in Geneva Nov. 15 1920 by a delegation headed by Sr. Antonio Huneeus, Minister of Foreign Affairs, who was honoured with the chairmanship of the commission on the admission of new states.

**Population.**—In the period between the census of 1895 and that of 1907 (the last official census), the pop. of Chile had increased from 2,712,145 to 3,240,279 showing an annual increase of 1.52%. The estimated pop. on Jan. 1 1918 was 4,038,050. The greatest absolute increase was shown by the province of Santiago in which is located the capital. An increase of more than 100,000 inhabitants was recorded for that province in the interval between the last two censuses. Other provinces that showed a large actual increase were Antofagasta, Valparaíso, Concepción, and Valdivia, while the province of Maule showed a decrease. The provinces of Atacama and Talca showed an estimated decrease in the 10-year period from 1907 to 1917. The great bulk of the population was still comprised within the 12 provinces in the Vale of Chile from Coquimbo to Concepción inclusive, although Antofagasta, Valdivia, and Llanquihue showed a larger actual increase than

did any of these 12 favoured provinces except Valparaíso and Santiago and a much larger proportionate increase than any of them. The territory of Magallanes showed an increase of more than 300% between 1895 and 1907 and a further estimated increase of nearly 100% in the succeeding decade. The percentage of urban pop. rose from 38.6% in 1895 to 43.3% in 1907 and as the estimated population for the 47 largest towns in 1918 showed a greater percentage of increase than for the country as a whole, the process of urbanization apparently continued.

According to the census of 1907 there were 134,524 foreigners in the country, representing 4% of the population. The chief nationalities represented were Peruvians, Bolivians, Spaniards, Italians, Germans, English, French and Argentinians in the order named. In the 10-year period 1907-17 there was a decline in the marriage-rate and in the birth-rate, but an even greater decline in the death-rate, so that the excess of births over deaths continued. The total excess of births over deaths in this period amounted to more than 350,000.

Provinces	Pop. Census 1907	Pop. Est. Jan. 1 1918
Tacna	28,748	39,357
Tarapacá	110,936	134,935
Antofagasta	113,323	220,049
Atacama	63,968	63,950
Coquimbo	175,021	191,117
Aconcagua	138,486	131,750
Valparaíso	281,385	347,757
Santiago	315,780	627,495
O'Higgins	93,429	125,847
Colchagua	159,039	163,407
Curicó	107,095	115,565
Talca	131,957	131,071
Maule	110,316	110,368
Linares	109,363	127,818
Nuble	166,245	198,908
Concepción	216,994	271,497
Arauco	61,538	74,974
Bío-Bío	97,968	106,510
Mallico	109,775	136,153
Cautín	139,553	164,463
Valdivia	118,277	187,202
Llanquihue	105,043	150,621
Chilo	88,619	99,044
Magallanes (Ter.)	17,330	32,623

Capitals	Pop. Census 1907	Pop. Est. Jan. 1 1918
Tacna	9,176	12,073
Iquique	40,171	46,941
Antofagasta	32,496	64,584
Copiapó	10,287	11,147
Serena	15,996	16,170
San Felipe	10,426	10,426
Valparaíso	162,447	212,659
Santiago	332,724	415,641
Rancagua	10,380	16,633
San Fernando	9,241	11,067
Curicó	17,573	23,071
Talca	38,040	42,563
Cauquenes	9,683	10,717
Linares	11,122	15,722
Chilán	34,269	39,601
Concepción	35,330	72,285
Lobó	2,687	2,687
Los Angeles	11,601	16,254
Angol	7,391	10,537
Temuco	16,037	21,635
Valdivia	15,229	26,091
Puerto Montt	5,408	7,807
Ancud	—	—
Punta Arenas	12,199	22,964

**Communications.**—By the end of the year 1918 there were in all 8,512 km. of railway in Chile of which the Government controlled 4,567 km. and private lines the other 3,945 km. The private lines were almost altogether in the three provinces of Tarapacá, Antofagasta and Atacama, in the two former of which (containing 97% of the total mileage of private railways) there were no Government-owned lines at all. Every one of the provinces had some railway mileage within it, varying from 9 km. in the territory of Magallanes to 1,840 in Antofagasta. One effect of the World War was virtually to suspend construction of all kinds of railways. In the six years 1909-14 the Government lines showed a loss of from 5,000,000 to 10,000,000 pesos (1 peso normally 15.6d.) each year; during 1915-7 they made profits of 4,738,423, 3,687,240, and 1,061,502 pesos respectively, but in 1918 they lost 9,124,365. During the 10 years 1909-18 the private railways showed profits from 9,000,000 to 20,000,000 pesos a year. As no explanation of

these figures is supplied, no comparisons can be based upon them. There were in 1918 nine electric traction companies carrying 180,388,425 passengers concentrated for the most part in the cities of Valparaiso, Concepción, and Santiago. There were also 35,120 km. of public roads and 70 km. of navigable rivers. The length of the Government telegraph lines amounted in 1918 to 15,687 km., operating through 370 offices and employing a personnel of 1,395. The private telegraph lines had in the same year an extent of 9,078 km. with 214 offices and 917 employees. In the years 1914-8 the Government-owned lines showed an excess of expenditures over income of from 100,000 to 1,750,000 pesos a year, while the private lines showed an excess of income over expenditure of from 1,000,000 to 4,000,000 pesos. No figures are available on which to base a comparison of the services rendered. The number of post-offices in 1918 totalled nearly 1,000, with 2,222 men and women employed. The postal revenues in that year amounted to 5,639,897 pesos and the expenditure for the same year to 5,253,283 pesos. The merchant marine in 1918 included 35 sailing vessels of 23,381 tons and 95 steamships of 46,587 tons total. The total number of vessels entered at and cleared from Chilean ports in 1918 amounted to 86,799 aggregating something over 25,000,000 tons. These figures were far below those which had been attained previous to the outbreak of the World War (1914). The four ports in which the entries and clearances exceeded 2,000, in the year 1917, were Punta Arenas, Valparaiso, Iquique, and Antofagasta, in the order named. Over half of these ships were Chilean, Great Britain ranking next, and Germany, of course, wholly eliminated from her former strong position by the war.

**Commerce.**—The effect of the war on the foreign commerce of Chile was of such a nature that statistics for the years 1914-8 must be regarded as largely abnormal. After a period of rapidly rising figures up to and including the year 1913, there came in 1914 a drop of about 20% in the total figures, followed in 1915 by a further decline which brought the totals below the figures attained in 1908. Then followed a marked increase in 1916 reaching a figure higher than the last pre-war year, and a tremendous increase in the two years following. In 1918 the total foreign trade of Chile amounted in value to 1,235,669,482 pesos gold, considerably more than double the value 10 years before. Of this sum imports represented 436,074,065 pesos, and exports 799,625,417 pesos, showing a favourable balance of 363,551,352 pesos. The principal countries of origin of the imports in 1918 were the United States, Great Britain, Peru, Argentina, India, France, Spain, Japan and Mexico. The value of the imports from the United States equalled the combined value of the imports from all the other countries mentioned, and was 2½ times the value of the imports from Great Britain, which in 1914 had been in the lead. The chief countries of destination of exports in 1918 were the United States, Great Britain, Argentina, Peru, Japan, Bolivia, France and Panama, in the order named. The United States alone received goods of a value equal to three-fifths of the total exports from Chile, and exceeded the value exported to Great Britain almost three to one, though in 1914 the exports to Great Britain exceeded in value those to the United States. The chief groups of imports arranged according to value were textiles, gold coin and bullion, chemical products, metals, machinery and implements, and food products. The chief exports arranged in the same manner were minerals, chiefly nitrate; the products of grazing, mostly wool and hides; the products of agriculture, mostly grains and legumes; and manufactured food products, principally flour and meal and preserved meats.

**Agriculture.**—The principal agricultural products showing the number of hectares in cultivation in each and the yield in cwt. appear from the following table for 1918.

Crop	Hectares Planted	Yield in cwt.
Wheat	484,951	5,647,584
Amber Wheat	42,088	644,719
Barley	39,680	719,312
Oats	32,190	461,088
Corn	26,466	367,236
Beans	52,950	693,144
Peas	16,308	145,828
Potatoes	32,806	2,623,587
Alfalfa	45,860	2,522,323
Clover	11,245	433,584

There were in 1918 a total of 66,727 hectares planted in vineyards yielding 1,555,543 hectolitres of wine. In 1917 the figures for the live-stock industry were as follows: 403,013 horses; 36,069 asses; 58,185 mules; 2,029,942 cattle; 4,182,910 sheep; 375,828 goats; 300,832 swine; and 33,506 llamas and alpacas.

**Manufactures.**—In 1917 there were 2,738 manufacturing establishments in Chile employing 64,660 persons and representing an invested capital of 596,265,540 pesos. The value of the output was 704,362,000 pesos. Rated according to the value of their output the chief manufacturing industries were those producing food supplies (which amounted to more than a third of the total), leathers, furs, gas and electricity, clothing, chemical products, paper and printing, metals, alcohol and beverages, lumber, tobacco manufactures, and textiles.

**Mining.**—In 1917 there were in Chile 98,621 mining properties, the value of whose licenses was 1,040,551 pesos. The value of the production of the principal minerals in 1917 is shown by the following table:—

Nitrate	510,367,506 pesos
Copper	143,512,182 "
Coal	87,740,800 "
Iodine	12,109,105 "
Iron	150,000 "
Borax	2,392,600 "
Sulphur	2,841,300 "
Salt	1,319,200 "
Silver	3,662,485 "
Gold	2,098,440 "

**Government and Education.**—In 1918 the police force of the republic, exclusive of the municipal police and a force of 2,131 *carabineros*, numbered 8,194. The army the same year comprised 996 commissioned officers of the line, and 82 officers of the intendancy or other service. The total number of troops including non-commissioned officers was 18,826. The navy in 1918 comprised 293 officers and a total force of 5,595 men. The ships were 52 in all, of which one was classed as a battleship, four as cruisers, two as armoured cruisers, two training ships, three transports, one gunboat, nine destroyers, six submarines, five torpedo boats, and the rest of a miscellaneous character, the total tonnage being 129,080. The value of the public works constructed in 1918 was 45,452,276 pesos, of which the largest expenditures were for the ports of Valparaiso and Santiago, roads and bridges, and public buildings. In 1918 there were 3,581 primary schools in Chile, of which 3,058 were Government schools, and 305 private schools receiving subventions; there were 287 secondary schools, of which 150 were Government schools and 86 private schools receiving subventions; and 19 institutions of higher learning, of which 12 were Government institutions, and one received subventions. The total number of pupils in the primary schools in 1918 was estimated at 397,721, almost equally divided between boys and girls, of which number 336,292 were in public schools. The number of pupils in secondary schools was estimated at 54,722, of whom 31,676 were in public schools. The students enrolled in 1918 in the institutions of higher learning numbered 4,875, of whom 4,228 were in Government institutions. There was a total of 105 daily papers, 81 semi-weeklies, 270 weeklies, 49 semi-monthlies, 126 monthlies, seven quarterlies and a number of miscellaneous publications, making a grand total of 698 periodicals of various kinds. The number of hospitals in the republic in 1917 was 109 with a personnel of 3,973, equipped with 2,217 rooms and 10,653 beds. The total number of patients admitted in 1916 was 108,945. There were in 1916 11,000 inmates of the various charitable institutions.

**Finance.**—On Dec. 31 1918 there were in circulation 227,688,421 pesos in paper currency. The total amount of gold in the conversion fund at the end of 1918 was 111,272,238. The Government expenses for 1918 amounted to 221,616,130 gold pesos and the receipts to 249,910,012 gold pesos. The national debt stood in 1917 at 625,712,416 gold pesos.

**Bibliography.**—Among the large number of works that appeared between 1910 and 1920 dealing wholly or partly with Chile, the following are worthy of special mention. (a) History:—Creusens Errázuriz, *Historia de Chile sin Gobernador* (1912); Don García de Mendoza (1914), and Francisco de Villagra (1915); Guillermo Arroyo Alvarado, *Historia de Chile* (1916); Alejandro Alvarez, *Rasgos generales de la historia diplomática de Chile, 1810-1910*; (b) Travel and Description:—J. P. Canto, *Chile: an Account of its Wealth and Progress* (1912); W. H. Koebel, *Modern Chile* (1913); J. G. Mills, *Chile: Physical Features, Natural Resources*, etc. (H. G. J.)

**CHINA (see 6.166\*).**—In the absence of any systematic census by the Chinese authorities the figures periodically published for the population of China must always be regarded as rough estimates. The Imperial Maritime Customs' Report for 1916 calculated the total pop. of the country, including the three Manchurian provinces (10,000,000), to be 445,873,000, but the arguments advanced by Mr. Rockhill in 1904 still justify doubts as to the evidence on which these estimates are based. Chinese records since the beginning of the 17th century show that at various periods the estimated pop. of the empire varied between 250 and 430 millions, and that its density always increased rapidly in times of peace and plenty only to be reduced with equal rapidity by outbreaks of floods, famine or civil war. Thus, in 1851 the pop. was believed to be about 430,000,000, but nine years later—after 12 provinces had been devastated by the Taiping rebellion—it was reckoned at 260,000,000. It is probable that in the period immediately preceding the revolution of 1911, the number of inhabitants in most provinces had attained to something approaching its normal maximum, but 10 years'

\* These figures indicate the volume and page number of the previous article.



incessant civil strife with widespread brigandage by lawless troops (in addition to the floods of 1911 and the severe famine of 1920-1 in the northern provinces) must have produced a great increase in mortality. Since 1907 there has been a steady migration of agricultural settlers from the congested provinces, especially Shaantung, into Northern Manchuria, Eastern Mongolia and Turkestan. The number of Chinese residents abroad was estimated in 1918 at about 9,000,000; of these, 2,258,000 were in Formosa; 1,500,000 in Siam; 1,825,700 in Java; 1,000,000 in the Straits Settlements, and 1,200,000 in the East Indies. The estimated number of Chinese in Australia was 35,000, and in Canada 12,000; in the United States it was in 1920 61,686.

**Social Life and Education.**—The political upheaval of the revolution of 1911 (see below, section *History*), the abdication of the monarchy and the abolition of the classical system of examinations for the civil service, naturally produced among the educated classes a relaxation of the ethical restraints and a disturbance of many of the popular beliefs upon which the social system of the Chinese is founded. The reverence displayed towards the canons of the sages and the Confucian doctrines (including ancestor worship) by the youthful iconoclasts who came to power with the proclamation of the republic, became speedily reflected in the widespread and increasing indiscipline of the student class, and in a loosening of that parental authority which is the keystone of the family system and of China's ancient civilization. Believing that the path to public office—common goal of ambition in China—would henceforward lie, not in study of the classics but in the acquirement of "western learning," men of wealth and influence were naturally disposed to allow their sons to acquire that learning, even if in so doing they should lose their reverence for the immemorial customs and ceremonial observances prescribed by the ancestral cult, and fall short of that filial piety which, according to the Confucian teaching, is the foundation of a well-ordered society. One of the first results of the revolution was therefore to give a fresh impetus to the activities of European and American missionary educational institutions and to extend the influence of western ideas in many directions; these found expression in the Government's endeavours to replace Chinese social customs and ceremonies by those of the West. After 1916, the increasing demoralization of the central Government produced a corresponding unrest and turbulence amongst the student class, which on several occasions successfully asserted its claim to intervene in questions of high policy and in foreign affairs. The strikes and the boycott of Japanese goods organized by students and young journalists (chiefly at the treaty ports) in 1919 afforded significant evidence of the relaxation of parental authority amongst the educated class of the urban population.

Considerable difference of opinion exists as to the extent of the influence of European ideas upon the social life and opinions of the agricultural and artisan classes, who constitute the great majority of the Chinese people, but it may safely be asserted that, generally speaking, the deep-rooted conservatism of the masses remains impervious to the chances and changes of the political world, and that in so far as they conform to the new ordinances promulgated by their rulers (as, for example, in the cutting of the queue); their acquiescence implies a desire to avoid trouble rather than any wide-spread desire for change, or any general departure from the philosophy of life prescribed by authority of immemorial tradition.

The republican Government's attempts to introduce by law innovations which run counter to ancient usage—such as the adoption of the western calendar and the proclamation of national holidays in connexion therewith—have been more honoured in the breach than the observance. Except at the treaty ports and the provincial centres of western learning, the elaborate ceremonialism which distinguishes every phase of social life in China remains practically unaffected by the promulgation of the law (Aug. 1912) intended to replace the etiquette and salutations of the old régime by the European custom of hat-raising and bowing. The reforms contained in the republican and socialistic programmes of the Kuo Min-Tang and other political societies

(including compulsory education, obligatory military service, equality of the sexes, etc.) became matters of frequent discussion in the vernacular press after 1912, and produced certain effects—most notably a movement for the emancipation of women—amongst the westernized element of the younger generation. As the number and circulation of Chinese newspapers penetrated farther and farther into the interior, an increasing number of the literate minority of the nation became familiar with these ideas, but they still contained no practical meaning for the masses. Similarly, by the Criminal Code, promulgated in March 1912 and revised in 1918, torture was abolished, the prison system reformed, and trial by jury introduced, together with many other reforms based on the most modern and humane legislation; but the Code remains generally a dead letter in so far as the general administration of justice is concerned. After the death of Yuan Shih-k'ai, the military governors in the provinces became practically independent of the central Government's authority; each within his own satrapy administered public affairs and justice as he thought fit, and since then the framing of national laws has been of little interest or benefit except to the law makers.

**Authorities.**—A. S. Roe, *China and Change in China* (1920); Paul S. Reisch, *Intellectual and Political Currents in the Far East* (1912); Emile Hovelague, *La Chine* (1920); Elizabeth Kendall, *A Wayfarer in China* (1913); R. F. Johnston, *Buddhist China* (1913); Y. K. Leong and L. K. Tao, *Village and Town Life in China* (1913); Timothy Richard, *Forty-five Years in China* (1916); E. H. Wilson, *A Nationalist in Western China* (1913).

**Political History, 1910-21.**—Most chroniclers are agreed in dating the revolution of 1911 from the outbreak which took place at Hankow in Oct., after the accidental explosion of a bomb and the arrest of a number of anti-dynastic plotters, but the country had undoubtedly contained all the materials for an upheaval since the death of the Empress Dowager in 1908. The causes of the revolution and of the disorganization of government which subsequently prevailed, were, like those of former rebellions, originally social and economic, ascribable chiefly to the disintegrating influence of "western learning" on the one hand, and, on the other, to the increasing burdens imposed upon the nation by foreign loans and indemnities. If the semi-westernized officials, politicians and students who came rapidly to the front after the initial successes of the rising at Hankow, were able to bring about the downfall of the Manchu dynasty and the establishment of a republic almost without a struggle, it was not because they represented any conscious objection to the monarchical form of government on the part of the masses, but because they constituted at the moment practically the only organized body of educated opinion in the country and were inspired by definite aims and ambitions. Dr. Sun Yat-sen and other active leaders of the revolutionary movement had for some years been conducting their anti-dynastic propaganda in the central and southern provinces, and popular resentment against the Manchus had gradually increased, partly because the dynasty had become identified in the public mind with floods and famines, and partly because of the Government's failure to prevent, and even to resist, the aggressions and encroachments of foreign Powers. The Cantonese leaders and agents of the revolutionary movement stirred up the people, and especially the soldiers, to vague fears and discontent by disseminating the idea that the Manchus were in league with foreigners to partition and disarm China. The agitation which they contrived to produce in the name of "sovereign rights," against the Government's negotiations for railway loans from abroad, led to the formation of numerous patriotic associations (chiefly at the treaty ports) which displayed great activity in the press and in the National Assembly. The signing of the Hukuang railway loan agreement at Peking (April 5 1911), in the face of strong opposition from the local gentry and literati of Szechuen, was skillfully turned to the purposes of the revolutionaries; rioting took place at Chengtu in July, to the cry of "sovereign rights" and by Sept. the province was in open rebellion. The opponents of the Government found further material ready to their hands in the aggressive designs manifested in Manchuria and Mongolia by Russia and Japan, and in Great Britain's occupation of the disputed Peking

district on the Yünnan border. The situation was such, in fact, that, failing a strong ruler at Peking, an upheaval had become inevitable, and its occurrence simply a matter of time and opportunity. The Manchus, seeking some means to avert the impending crisis, had tried several methods of concession, intended to placate Young China. In Nov. 1910, they had yielded to the demand of the National Assembly and promised the convening of the promised parliament for 1913; six months later, the Regent had agreed to replace the Grand Council by a responsible Cabinet. The Imperial Clan was divided against itself at this critical juncture by a struggle for supreme power between the Regent and the Dowager Empress Lung Yu, widow of H. M. Kuang Hsi; divided also, because several of its leading members, under the influence of Prince Tsai Tao, were in favour of a policy of constitutional reform. But even had it presented a united front, the forces which brought about the abdication of the dynasty were beyond its strength.

When, immediately after the outbreak at Hankow, the mutineers captured the Wuchang mint and the arsenal at Hanyang, it soon became apparent that the Regent possessed no resources either of strength or of statecraft. Seriously alarmed by the rapid spread of the rebellion, he was persuaded to call to his aid the famous Chinese viceroy, Yuan Shih-k'ai, whom he had disgraced and dismissed from office in Jan. 1909. By an edict of Oct. 14 1911 Yuan was recalled from his retirement and appointed viceroy of Hunan and Hupel, with supreme command of the Imperial forces. From this date until his death (June 1916) the direction of affairs at Peking lay in his hands.

Yuan Shih-k'ai's military operations on behalf of the monarchy were half-hearted at best and require but little comment. He took the field towards the end of Oct. but returned to Peking on Nov. 13, having been elected prime minister on the 8th. At the end of Nov., after desultory fighting, the position of the rebels in and around Hankow had become untenable. But by this time the propaganda work done by Sun Yat-sen's emissaries, combined with the helplessness of the Manchus, had borne fruit.

Fourteen provinces—or rather their officials—had declared for the revolutionaries and against the monarchy, whilst the attitude of influential mandarins like Tang Shao-yi and Wu Ting-fang, who had risen to eminence under the Empress Dowager, was indicative of the fact that the movement was not likely to be suppressed by military force. Nanking held out for the Imperialist cause until the beginning of Dec., at which date Yuan Shih-k'ai agreed to an armistice, for the purpose of discussing the whole situation with the revolutionary leaders. From the outset, after his recall to power, Yuan had done his utmost to stem the tide of disaffection and to preserve the monarchy, shorn of its privileges, as the centre of a reformed constitutional system. He had consistently resisted the demands of the radical extremists, and when, as the result of the increasing demoralization of the court and the sympathetic attitude of the foreign press towards the revolution, Sun Yat-sen's party began seriously to proclaim their intention to establish a republic, he did everything in his power to prevent it. He publicly declared his belief that the overthrow of the throne must mean chaos "amidst which all interests would suffer, and there would be no peace in the empire for several decades." When finally he consented to parley with the revolutionary leaders, he was fighting practically single-handed for the principles in which he believed. The National Assembly, which had adhered to the constitutional programme, had been denounced and superseded by the Kuo Min-tang's Republican Committee at Shanghai, early in November. The British Government and others, which had warmly advocated his recall to office at the beginning of the rebellion, had failed at the critical moment to give him the moral and financial support which he had every reason to expect, and it was evident that without a large foreign loan, his position was hopeless; the Regent had abdicated (Dec. 6) and Tang Shao-yi, the ablest of his lieutenants, had frankly declared his sympathies with the Cantonese republican party.

The armistice negotiations commenced at Hankow on Dec. 11, with Tang Shao-yi acting as Imperial delegate. On the 18th they

were transferred to Shanghai upon the dismissal of the Republican Committee. The result was a foregone conclusion; before the end of the month, the Manchu court had agreed to submit to a National Convention the question of monarchy or republic. On Dec. 25, Dr. Sun Yat-sen, who had been in England when the revolution began, arrived at Shanghai; a week later, a council of provincial delegates at Nanking elected him to be first President of the Chinese Republic, and on Jan. 1 1912 he took the oath of office. On the 12th, the court being terrified by bomb outrages at the capital, the Emperor's abdication was proclaimed in an edict which transferred the government to the people's representatives and declared that the constitution should henceforth be republican. By the same edict, Yuan Shih-k'ai was given full powers to organize a provisional republican government. On Feb. 14, Dr. Sun Yat-sen resigned the presidency in favour of Yuan Shih-k'ai, who was elected provisional President by the Nanking Council and took the oath of office at Peking on March 10. Li Yuan-hung was elected vice-president and a provisional constitution was adopted by the Nanking delegates. On April 2, the Government of the republic was transferred from Nanking to Peking. A new provisional council was formed consisting of five members from each province, elected by the provincial assemblies, five members each from Inner and Outer Mongolia and Tibet, and one member from Kokonor.

Yuan Shih-k'ai's position as President of the republic was one of great difficulty and danger. He had never been at pains to conceal his dislike for the political ideas of the Cantonese party, or his conviction that the monarchical form of government was best suited to the needs of the Chinese people; in the eyes of the Kuo Min-tang Radicals, he was therefore suspect from the outset. If they professed to believe in his conversion to Republicanism, it was because his was the only name likely to inspire the masses with respect for the new régime, and also because they expected him to play the part assigned to him with due respect for the interests of those who had placed him at the head of affairs. In addition to the chaos of the internal situation (already clearly manifested in the struggle for supremacy between rival military chieftains) he was faced with grave financial problems, chiefly due to the fact that the fiscal machinery of the empire had been completely disorganized by the revolution. There were, moreover, increasing difficulties in the field of foreign affairs. Nevertheless, by consummate ability of statecraft, he succeeded during the next four years in bringing something like order out of chaos and gradually restoring the authority of the central Government in the provinces. During his first year in the presidency, the Kuo Min-tang Radicals were still powerful enough to compel him to adopt a policy of watchful waiting and to concentrate his attention upon ways and means for raising money abroad. So long as his treasury remained un replenished, his position necessarily lacked the prestige which the financial support of the Powers confers, and he had no means of securing the support of the military chieftains, whose troops were usually at the service of the highest bidder. It was not until April 25 1913 that, after prolonged negotiations with the Six-Power group of financiers, Yuan's Minister of Finance succeeded in concluding the "Reorganization" loan, which placed him in possession of the sinews of war to the amount of about 10 millions sterling. His financial position and the moral support of the foreign Powers thus secured, Yuan proceeded to show his hand and to defy the Kuo Min-tang. The latter had secured a powerful majority at the elections held in the beginning of the year. They came to Peking for the opening of Parliament (April 7) in a belligerent mood, greatly exasperated by the assassination at Shanghai of one of their ablest leaders, Sung Chiao-jen, the speaker-elect, whose death was undoubtedly planned and carried out by the President's orders. Assembled under these conditions, the life of the new Parliament was not destined to be a long one; its career, indeed, began and ended with the election of speakers for both Houses. Yuan Shih-k'ai refused to recognize its claim to supervise and sanction his loan negotiations and ordered the conclusion of the agreement with the foreign banks in despite of the agitated protests of the Radical leaders. Realizing the danger of their position many

of these now fled from Peking, and in the central and southern provinces "a war to punish Yuan" was begun. It lasted only two months and ended in a complete rout of the disorganized forces led by Generals Li Lieh-chun and Huang Hsing. Yuan was now firmly in the saddle.

After thus forcibly asserting his authority, Yuan proceeded to vindicate and consolidate it. In the first place, by the lavish use of money and the display of military force, he succeeded in securing his election as President for a term of five years—his title having hitherto been provisional. On Oct. 10 1913 he took the oath of office with much pomp and circumstance, in the throne room of the Winter Palace; and availed himself of the occasion to declare that, for the future, he intended to rule without interference and in accordance with ancient tradition. Four weeks later, a presidential mandate, endorsed by his docile Cabinet, ordered the unseating of all the Kuo Min-tang members of Parliament, on the ground of their treasonable conspiracies. As half of the Senate and more than half of the House of Representatives were thus disposed of, no parliamentary quorum was left. All obstacles to the exercise of Yuan's autocratic authority were thus removed. He continued for a while to profess respect for the principles of constitutional government and loyalty to the republic, but it speedily became apparent that the ideas which inspired his policy were those which he had frankly proclaimed during the crisis of the revolution.

The Parliament at Peking was replaced by a political council and "an administrative conference for the revision of the constitution" composed almost exclusively of officials and *litterati* of the old school, selected by the President or by his agents and representatives in the provinces. The provincial assemblies were dissolved, on the carefully directed recommendation of the military governors, "for perversely usurping financial authority and obstructing the business of administration." By the beginning of 1914, it was evident that Yuan intended to restore the old orthodox autocracy and centralization of power in the metropolitan administration; it was also evident that, so far as the great mass of the people was concerned, his policy evoked little or no opposition and that, so far, he was justified in his declared belief that they were "no lovers of changes that ran counter to immemorial custom."

When, upon the advice of his administrative council, the President Dictator announced his intention of performing the Winter Solstice ceremony at the Temple of Heaven and restoring the official worship of Confucius, he proclaimed himself to that nation as an autocratic ruler and gave the first indication of his own imperial ambitions. There is reason for believing that these ambitions had no place in his mind when, in 1911, he strove to uphold the Manchu dynasty, but that they gradually and insidiously asserted themselves, partly as the result of the exercise of despotic authority and partly by reason of the death of the boy Emperor's guardian, the Empress Dowager Lung Yu (Feb. 1914). Even when his intentions had become unmistakably clear, he fully realized the dangers which confront the creation of a new imperial line under a political system in which the divine right of rulers is intimately bound up with the sacred institution of ancestor worship; but he took his risks and carried his principles to a conclusion for which there were precedents in history and justification in the situation itself. Had the question of his claim to the throne been decided simply as a matter of internal politics, he would probably have succeeded in establishing and extending his effective authority with the general consent of the nation, wary of civil strife and disorder. But Japan's assertion of her "special rights" and material interests in China, greatly increased after the outbreak of the World War and the expulsion of the Germans from Kiaochow, plainly indicated that Yuan Shih-k'ai would not have a free hand in the matter. His inability to discern the serious danger of intervention from this quarter was the weakest point in his armour; indeed, his failure to grasp the international situation afforded a remarkable contrast to the perspicacity he displayed in dealing with his own countrymen.

Within a year of the outbreak of the World War, the movement for the restoration of the throne in China had assumed

definite form and direction. The Chou-An-hui society, composed chiefly of Yuan's supporters, organized an energetic monarchical propaganda at Peking and in the provinces, but they, like the President, failed to draw from the "21 Demands" (which Japan had forced upon the Chinese Government in May 1915) the obvious conclusion that the Japanese Government would strongly oppose Yuan's plans in the event of his advancing serious claims to the throne. During the negotiations which took place between Jan., when the "21 Demands" were first presented, and May, when they were imposed by an ultimatum, the President's attitude towards the Japanese was evasively conciliatory, but it failed to reveal appreciation of the truth that since the days of his residency in Korea he had never been *persona grata* in Japan, and that the Government at Tokyo would therefore do its utmost to prevent his assumption of autocratic power. One of the ablest and most influential scholars in China, the famous political writer, Liang Ch'i-ch'ao, who had strongly supported Yuan's fight for the preservation of the monarchy in 1911, stood forward boldly in Aug. 1915, to denounce the Chou An-hui's propaganda and to warn the President of the perils which threatened the course upon which he was embarking. Resigning his position on the State Council, Liang proceeded to publish his opinions in the *Peking Gazette*, opposing Yuan's accession to the throne, partly on grounds of classical orthodoxy and partly because he perceived the inevitability of Japanese intervention. Yuan, well aware of the far-reaching influence of Liang's views, did all in his power to win his support. Failing in this, he made a pretence of constitutional procedure by referring the question of the monarchy to a vote of the provinces, or rather, to the vote of a number of individuals appointed by himself to represent them. The result, a foregone conclusion, was a practically unanimous vote (Nov. 5) in favour of Yuan's accession.

But Liang Ch'i-ch'ao's wisdom was rapidly justified. On Oct. 30, the Japanese minister, supported by his British and Russian colleagues, conveyed to the President, through his Foreign Office, friendly "advice" to the effect that the Japanese Government deprecated the idea of his restoring the monarchy in his own person, on the ground that the change would lead to serious internal dissensions. Yuan's reply was dignified but short-sighted; he informed the Japanese minister that his Government was quite capable of preventing disorder in China, and that he looked to the Governments of friendly Powers to control the activities of Chinese revolutionaries within their territories. On Nov. 9 the Chinese Government, in announcing the result of the provincial "vote," intimated that no change would take place before the New Year; but this decision was rescinded, and matters hastened by an abortive insurrectionary movement which occurred at Shanghai on Dec. 6. The State Council thereupon memorialized the President to put an end to the prevalent uncertainty and unrest by proclaiming himself Emperor without further delay. On the 12th the monarchy was proclaimed, and the announcement was made that the inauguration ceremony would take place on Feb. 9.

It was not to be. Within a week of the proclamation of the monarchy, a rebellion broke out in the far-western province of Yunnan, led by Tsai Ao, a military official educated in Japan. On Dec. 27 the province, through its officials and local gentry, declared its independence in opposition to the monarchy. Thereafter, in spite of initial successes gained by the Government's forces, the insurrection spread with a rapidity which justified the foresight of Liang Ch'i-ch'ao and emphasized the fact that, as matters stood, Yuan Shih-k'ai had not achieved either the personal prestige or the pecuniary resources sufficient to command for his authority as Emperor the respect and loyalty of the semi-independent chieftains of the provinces. By the end of Jan. Kuangsi and Kueichou had renounced their allegiance and other provinces were wavering. His star was so rapidly declining that his advisers persuaded him to issue an official announcement (Jan. 22) postponing indefinitely the establishment of the monarchy, in view of the country's internal dissensions. Having thus confessed to failure, when within sight of the summit of his ambitions, Yuan's fate as a ruler was sealed. By the end of

March his opponents had become so many and so active that his remaining friends advised him to resign the presidency and retire into private life. A month later he had been denounced as a usurper in nearly every province by the very men who had "elected" him to the throne in Nov., and even at Peking there were but few to do him reverence. Nevertheless he declined to resign the presidency, and attempted a compromise by issuing a mandate (April 22), which transferred all civil authority to a reorganized Cabinet under the premiership of Tuan Chi-jui, an able and ambitious official, who had first achieved distinction, as Yuan's Minister of War, by suppressing Sun Yat-sen's revolution in 1913. In order to placate the Cantonese and other disaffected elements in the South, the President announced his intention of reintroducing parliamentary government without delay. But the Kuo Min-tang Radical leaders were not disposed to come to terms with Peking; the absence of any effective authority at the capital merely served to stimulate new ambitions and create new causes of conflict amongst the political factions. The Kuo Min-tang, repudiating Yuan Shih-k'ai, therefore proclaimed the establishment of a new provisional Government at Canton and elected the Vice-President Li Yuan-hung to the presidency. Peking was now confronted with a renewal of civil war and by a situation which Yuan's persistence in retaining office rendered peculiarly difficult. But at this juncture Yuan died, worn out by an illness which chagrin had aggravated, and Li Yuan-hung duly succeeded to the presidency.

It soon became apparent that with Yuan Shih-k'ai had passed the only hope of restoring a strong central Government in China. Had he lived and succeeded in restoring law and order, he might also have succeeded in turning to his country's permanent advantage the favourable economic situation in which the European War had placed it: But with his death the affairs of the nation became once more involved in a chaotic confusion of personal ambitions and political rivalries, and the functions of Government were rapidly transferred from the civil to the military organization. At the date of Yuan's death, the fiscal relations between Peking and the provinces which he had begun to reorganize in 1914, had completely collapsed, as the result of the new insurrectionary movement; the central Government was confronted by an empty treasury and without means of replenishing it, other than foreign loans. The Government banks at Peking had suspended specie payments in May 1916 and the military governors of the northern provinces, on whose support the administration depended, were loudly clamouring for money wherewith to pacify their unpaid troops. Tuan Chi-jui, as premier of the new Cabinet, endeavoured to disarm the opposition of the Southerners and to secure support for the metropolitan administration, by convening the Parliament which Yuan had broken up in 1913, to meet at the capital on Aug. 1. At the same time he sought to win over the most influential of the Cantonese leaders, Tang Shao-yi (prominent before the revolution as a metropolitan official and protégé of Yuan Shih-k'ai), by offering him the Ministry for Foreign Affairs. But Tang Shao-yi and his colleagues of the Canton provisional Government showed no desire for unity; on the contrary, denouncing the Peking administration as "militarists" and monarchists in disguise, they professed to insist upon the immediate restoration of the provisional constitution adopted by the revolutionary leaders at Nanking in 1911. Subsequent events proved clearly that no devotion to any political principle lay behind their factions, and that the central Government could never have disarmed their opposition by granting the Nanking, or any other, constitution. The nation was doomed to civil strife by reason of rivalries that were, and still are, personal and predatory, and which only lawfully constituted authority, backed by disciplined forces, could ever overcome. At the opening of Parliament on Aug. 1, two facts were speedily made manifest: firstly, that the Kuo Min-tang's repudiation of Peking's authority had not been inspired solely by Yuan Shih-k'ai's attempt to restore the monarchy and would not end with it; secondly, that the existence and proceedings of Parliament, no matter under what constitution convened, were completely at the mercy of the military governors. One

of the first steps taken by Gen. Li Yuan-hung, as President of the republic, was to call a meeting of generals and to inform them that the country's destinies lay in their hands. Thereforward the northern military governors, led by the premier Tuan Chi-jui, became the dominant factor of the situation. At the outset they were frankly opposed to the revival of the Nanking constitution and to the reassembling of the Parliament of 1913; while the navy, with its headquarters at Shanghai, was equally decided in its refusal to acknowledge the authority of Peking until Parliament had resumed its functions. Finally, a compromise was reached by the formation of a new Cabinet wherein the South was represented. Parliament, in which the Kuo Min-tang party predominated, declared its intention of adhering to the Nanking provisional constitution, pending the completion of a new and permanent instrument, for the preparation of which a special drafting committee was appointed. But it was not long before the military governors made it plain that, while they might permit the parliamentarians to debate their theories of government, its practice would continue to be determined by their own necessities, and that the chief problem with which the Cabinet would henceforth have to grapple, lay in the provision of funds for the maintenance of their uncontrolled and uncontrollable armies. After the passing of Yuan Shih-k'ai the history of the Chinese Government became a series of expedients and experiments intended to provide a temporary solution of this problem, all of which tended to aggravate its difficulty.

At the time of his "election" to the throne, in Nov. 1915, Yuan Shih-k'ai had made certain tentative overtures through the legations at Peking, with a view to China's abandonment of neutrality and her espousal of the cause of the Allies. By the adoption of this course he hoped not only to obtain the financial relief which he required, but to make provision for assistance in the future against the policy of encroachment displayed by Japan in the "21 Demands." But he was compelled to abandon negotiations to this end, because of the troubles that began to press upon him and because of the Japanese Government's unconcealed opposition to the proposal. After his death, however, the chief reason for this opposition was removed and in the winter of 1916, the question of China's joining the Allies came to be seriously considered by Tuan Chi-jui's Cabinet. The premier and most of his colleagues were anxious to take this step, because it offered an opportunity of suspending the Boxer indemnity payments and of securing Chinese representation at the Peace Conference at the close of the war. But amongst the older officials, there were some (including the President) who, greatly influenced by the activities of German agents and their lavish propaganda, preferred a policy of passive neutrality. Opinion was therefore divided and before the question was finally settled (March 11) by a decisive vote of both Houses of Parliament, it had become inextricably involved in the dissensions and intrigues of the rival political factions at the capital, and had led to an open breach between the Premier and the President. On Feb. 4 the U.S. minister at Peking invited the Chinese Government to follow the example of the United States by formally protesting against Germany's submarine campaign and by severing diplomatic relations; on the 9th, the Chinese Foreign Office conveyed an intimation to the German minister in the sense required. The premier's party were now for immediate action, but their policy was opposed and denounced by the German-subsidized section of the press and by the President's party in Parliament, advocating cautious delay. On Feb. 28, the Allied ministers at Peking, by a joint memorandum, notified the Chinese Government that if diplomatic relations with Germany were severed, the Powers would suspend the Boxer indemnity payments and consent to a revision of the Chinese customs tariff. The premier, after consulting his supporters at Peking and in the provinces, decided to act upon this advice and to instruct the provincial authorities accordingly. The President's refusal to confirm these instructions led to a ministerial crisis; eventually, after the premier had tendered his resignation, the President gave way. Tuan Chi-jui's policy having been endorsed by Parliament, relations with Germany were severed on March 14 1917; on the

same day the German ships at Shanghai and Amoy were seized by the Chinese authorities, and on the 25th the German minister and his staff left Peking.

The premier and his supporters were now anxious to carry their policy to its logical conclusion and to secure the benefits of complete identification with the cause of the Allies, by declaring war against the Central Powers. A conference of military governors convened by the premier at Peking on April 26 voted decisively for war; a few days later the Cabinet adopted a unanimous resolution to the same effect. But once again the national aspect of the question became submerged in a welter of factional intrigues. The President's party, consisting of a number of Kuo Min-tang parliamentarians, who professed to see in the attitude of the military governors a menace to parliamentary government, and of others alarmed by the increasing rumours of secret agreements between Tuan Chi-jui's party and the Japanese Government, constituted an opposition sufficient to prevent the Cabinet from carrying its resolution into effect. Among the *liberals* and disinterested patriotic men there undoubtedly existed a genuine difference of opinion as to the advisability of committing the nation definitely to a policy of hostility to Germany, a difference which was reflected in the conflicting advice publicly given by scholars like Liang Ch'i-ch'ao and Kang Yu-wei. But so far as Parliament was concerned, the question resolved itself into a sordid struggle for power between Tuan Chi-jui, backed by the northern Tuchuns, and his political opponents. At a secret session of the Lower House of Parliament on May 10, it was apparent that the question of war with Germany had become subordinate to that of a combined attack upon Tuan Chi-jui. On May 19 a resolution was adopted to the effect that the House would decline further to consider the question until the Cabinet had been reconstructed. As Tuan's colleagues with one exception had resigned at the first sign of serious trouble, the resolution amounted to a demand for the premier's resignation. Tuan, however, held his ground stoutly and countered the Kuo Min-tang move by a communication from the military governors to the President demanding the immediate dissolution of Parliament, and by the announcement of their intention not to leave the capital until this had been done. Thus challenged, the President issued a mandate (May 23) dismissing the premier and appointing the septuagenarian Wu Ting-fang in his place. Tuan, following the course usual on such occasions, fled from the capital and, taking refuge with the military party's leaders at Tientsin, announced his intention of defying the President's authority. The military governors of several provinces north of the Yangtze thereupon proceeded to declare their independence of the central Government whilst the Kuo Min-tang leaders, hurriedly leaving the capital for the South, announced their intention of taking up arms in defence of Parliament and the people's liberties. It is typical of the chaotic condition of Chinese affairs that at this juncture Gen. Feng Kuo-chang, the Vice-President, while tendering his resignation, announced that the lower Yangtze region would remain "neutral."

The struggle thus began lasted for three months and postponed China's declaration of war against Germany until the middle of August. As it proceeded, it became more and more apparent that the contending factions were not really concerned with any question of political principles, but fighting only for place and power. At the beginning of June, the military governors established a "Provisional Government" of their own at Tientsin with the aged ex-vice-roy, Hsü Shih-chang (later President of the republic), cast for the dummy rôle of president-dictator. At the same time they warned Li Yuan-hung that if he desired to remain President, he must submit to their wishes and dissolve Parliament; to enforce their demands they proceeded to mass troops in the vicinity of the capital. Li Yuan-hung sought to gain time by summoning to his aid as "mediator" Gen. Chang Hsün, the famous swashbuckler chieftain of Shantung fame. Gen. Chang promptly came north with a "body-guard" of several thousand troops, and arrived at Peking on June 12; but the value of his mediation was discounted in advance by the announcement that he would insist upon the dis-

missal of Parliament, and by rumours of his intention to restore the Manchu dynasty. On June 13 Li Yuan-hung yielded, and Parliament was dissolved by presidential mandate.

The question of joining with the Allies against Germany was now relegated by common consent to the background and all attention concentrated on the struggle of personal ambitions at Peking. Tuan Chi-jui, with his Tuchun supporters, was still in watchful waiting at Tientsin. Parliament had elected a new Premier (Li Ching-hai) but the attitude of the military party made it an uncomfortable post to fill and he had cautiously declined to assume office. Many of the Kuo Min-tang politicians had fled to Shanghai and Canton and, with the support of the navy, were once more preparing to take the field against Peking. Under these conditions the danger of internal dissensions on a wide scale without definite purpose was unmistakably more serious than at any time since the overthrow of the Manchus. Regarding the matter in this light, the United States addressed a note to the Chinese Government (June 6) deploring the prospect of civil war and intimating that the restoration of national unity was a matter of more immediate importance to China than the declaration of war against the Central Powers. This advice, though morally sound, was politically unfortunate, inasmuch as it was construed and proclaimed by the Kuo Min-tang as an intimation that the U.S. Government was opposed to the policy of Tuan Chi-jui and his military supporters; it therefore resulted in stiffening Young China and the Cantonese Radicals in their uncompromising hostility to the central Government. It was common knowledge that Tuan Chi-jui had framed and pursued his policy in close touch with Japan, and that he relied upon that country for financial support; it was only natural therefore that Young China should look to the United States not only to deliver them from the militarist and monarchist party, but to protect the Chinese republic from Japan.

General Chang Hsün, as the central figure on the Peking stage, soon showed that he had no intention of attempting to bring about a reconciliation between President and premier. His proceedings were so obviously inspired by his own overweening ambitions that it was not long before signs of dissension manifested themselves between him and his colleagues of the military party. When his policy became fully revealed by a *coup de main* (July 1) which withdrew the young Emperor from his retirement and proclaimed the restoration of the Dragon Throne, the chief cause of the opposition which his action promptly evoked from Tuan Chi-jui and the Peiyang military chiefs lay in the fact that he proposed to appoint himself regent and viceroy of Chihli. Few, if any, of those who now denounced Chang Hsün as a traitor to the republic and took the field against him, were in reality opposed to the monarchy (most of them were, in fact, solemnly pledged to support the restoration); but they could not brook the assumption of supreme authority by one who had stolen a march upon them and taken advantage of their divided counsels. Tuan Chi-jui, in particular, was known to be in favour of the monarchy, but only on condition that he himself became viceroy of Chihli and the power behind the throne. Emerging therefore from his retirement at Tientsin, he led his army to the capital to defend the republic. After a few days of desultory and half-hearted fighting, Chang Hsün capitulated (July 12) and the young Emperor was consigned once more, with all due respect, to the tranquil dignity of his court without a kingdom. Chang Hsün's troops were permitted to retire, with the honours of war and three months' pay; their leader, who had found a temporary refuge in the Dutch legation, was left unindicted.

In "vindictating the Republic," Gen. Tuan had received the active support of the Vice-President, Gen. Feng Kuo-chang, commanding the army at Nanking. After the capitulation of Chang Hsün, Tuan resumed the premiership, with powers that were practically those of a dictator, so that the position of Li Yuan-hung as President became impossible. From the Japanese legation, whither he had fled for safety upon the proclamation of the monarchy, he announced his intention of retiring into private life. On July 18 he was succeeded in the presidency by

Feng Kuo-chang, who declared his readiness to endorse the policy of the premier in the matter of declaring war against the Central Powers. The agreement thus reached gave promise of a united administration and a clear-cut policy at Peking; nevertheless, it failed to reconcile the disaffected elements represented by the Kuo Min-tang. These declared the new Government to be illegally constituted and demanded the immediate convocation of Parliament; failing which (as a proclamation by Sun Yat-sen announced) it would meet, under a provisional Government, at Canton. Undeterred by this opposition, the premier, after receiving certain assurances from the Allied ministers, notified them that China would declare war against Germany so soon as the new President had assumed office. Feng Kuo-chang arrived at Peking on Aug. 1; two days later, the Cabinet adopted a unanimous resolution in favour of the declaration of war, which was formally issued on Aug. 14.

The critical situation in Russia and the impossibility of predicting the future policy of that country, made it difficult for the Allied Governments to come to a common understanding in regard to the financial and other advantages to be conceded to China upon abandoning her neutrality. It was eventually agreed to suspend the Boxer indemnity payments and to authorize an increase in the Maritime Customs tariff; and at the same time the Government's immediate necessities were relieved by a loan of 10 million yen from the Consortium banks.

With its foreign debt obligations thus diminished and its revenue materially increased by Sir Richard Dane's highly successful reorganization of the salt *gabelle*, the Chinese Government had an opportunity of regaining financial and political equilibrium such as had not occurred since the beginning of the century. Had Tuan Chi-ji seized the opportunity by offering to the southern leaders representation in the Cabinet and a fair share of the sweets of office, harmony might possibly have been restored; but he refused to do so and his new Cabinet (July 17) contained only representatives of the military party and the Chin Pu-tang. The result was a rapid development of a new separatist movement in the South, which had begun in June, after the dissolving of Parliament, by the secession of Kwang-tung. Henceforward, during the period with which we are dealing, the history of China becomes an increasingly hopeless tangle of faction feuds. Almost before the new President had assumed office at the capital, his adherents (the Chihli group of the Peiyang party) were in conflict with the premier concerning the policy to be adopted in dealing with the South; Tuan Chi-ji being all for strong measures, and Feng Kuo-chang for conciliation. As the result of these differences, Tuan Chi-ji once more resigned; but again his friends, the military governors, intervened and proclaimed their intention of carrying on the war against the South, with or without the consent of the Government. Eventually Gen. Chang Tao-lin, the Tuchun autocrat of Manchuria, put an end to all further peace talk by moving a large body of troops into Chihli; Tuan Chi-ji thereupon resumed the premiership and, with the support of the northern Tuchuns, took up the offensive against the southern provinces.

Having "vindicated the Republic," it was necessary for Tuan Chi-ji to maintain the appearance of constitutionalism. He therefore convened an assembly, which proceeded to revise the law for parliamentary elections. This having been duly promulgated (Feb. 17 1918), a new Parliament (considerably reduced in numbers) was elected, in time to deal with the tri-annual election of the president.

On Sept. 4 the presidential election took place, but the matter had been decided in advance by the military Tuchuns, assembled in conference at Tientsin. Feng Kuo-chang was passed over, because of his inability to work with Tuan Chi-ji, and in his place was elected Hsu Shih-chang (in 1922 President of the republic), a veteran official who had achieved a reputation for sagacity as viceroy of Manchuria and guardian of the heir-apparent under the monarchy.

Meanwhile, headed by the Chinese guilds and chambers of commerce at the treaty ports, a strong movement had begun to manifest itself on the one hand against the continuance of civil

war, and on the other against the subservience and venality of the Peiyang politicians in their dealings with Japanese agents. This attitude of the business community was endorsed and the country's urgent need of peace emphasized, by earnest representations addressed to the Chinese Government by the Allied ministers at Peking. The new President was well aware of the dangers of China's internal and international position; by temperament and training inclined to methods of conciliation, he did all in his power to restore peace and goodwill between the Peiyang party and the Cantonese leaders of the South. On Nov. 16 he issued a presidential mandate, calling upon the commanders of the northern forces to suspend hostilities and to keep within their own lines. This armistice was followed by negotiations for a conference (eventually convened at Shanghai) with a view to removing the alleged grievances of the southern Constitutionalists and finding means to amalgamate the rival parliaments under a coalition Government. The President's action was undoubtedly influenced, and the peace movement strengthened, by the Allies' victorious conclusion of the war; for a little while it seemed as if the Shanghai conference might lead to some definite and satisfactory conclusion, but in the end it merely served to demonstrate the fact that neither party had any sincere desire to put an end to the civil strife, from which not only the northern Tuchuns but the southern parliamentarians profited.

As leader of the southern delegates at the Shanghai peace conference, Tang Shao-yi demanded the cancellation of the Government's military agreement with Japan, the abolition of the War Participation Bureau, and a pledge that the Peking authorities would accept no further financial assistance from Japan. Most of the eight demands which he laid before the northern delegates (May 1919) evoked but little public interest, but the increasing evidence of Japanese political and financial ascendancy at Peking produced a strong manifestation of opinion by Young China in support of the southern party's attitude, which was greatly increased by the decision of the Versailles Conference in regard to the Shantung question. The Sino-Japanese military agreement (March 1918) was the most important of several secret pacts concluded by Tuan Chi-ji's Cabinet. It was ostensibly intended to provide for united action by China and Japan against German and Bolshevik activities in Siberia, and especially for the protection of the Siberian railway; but, according to the leaders of the southern party, it not only gave Japan a steadily extending control over China's military forces in the North, but it virtually reestablished many of the "protectorate" conditions which had been imposed (and subsequently withdrawn as the result of representations by the Powers) under Group V. of the "21 Demands" of May 1915. So strong was the feeling produced by the student strike, the boycott, and other manifestations of Young China's indignation at the increasing evidence of Japanese ascendancy at Peking, that the Chinese Government was compelled to instruct its representatives at Versailles not to sign the Peace Treaty; and two of the members of Tuan Chi-ji's Cabinet, who were most prominently identified with the Government's financial dealings with Japan, were compelled to resign. The attitude of the southern party remained, however, irreconcilable, and the renewed discussions of the Shanghai peace conference were fruitless; indeed, a fresh cause of offence was proclaimed by the southern delegates in the fact that the military agreement, which should have automatically ended at the same time as the Allied intervention in Siberia, remained in force by virtue of a new pact, said to have been secretly concluded at Peking in March 1919.

Since the death of Yuan Shih-k'ai, the position of the group of politicians in control of the Government at Peking had become entirely a question of funds, in the sense that Tuan Chi-ji and his supporters were continually confronted by the alternative of either retiring into private life or of raising money sufficient to retain the support of the northern military governors. It was a position which never offered any prospect of stability or permanency; no Government could hope to maintain itself in power if once its borrowing capacities were exhausted. In the summer of 1920 the inevitable happened. Denounced by Young



China, attacked on all sides for having sacrificed the nation's sovereign rights, and abandoned by many of their dearly bought supporters. Tuan Chi-jiu and his colleagues of the Anfu Club were forcibly driven from power. The control of the Government passed then from their hands into those of the Chihli faction, headed by the President and the two powerful Tuchuns, Chang Tso-lin and Tsao Kun. This defeat and expulsion of the premier were hailed by Young China as a victory for the constitutionalist cause and hopes were expressed that the popular Gen. Wu Pei-fu, whose troops from the Yangtze had played a decisive part in the struggle, might be able to carry out his plans for a citizen convention and thus unite the rival parliaments. But these hopes were short-lived. Gen. Wu Pei-fu and the national convention were very speedily relegated to the background, while the struggle for place and power was renewed on the old lines between new groups of rival politicians. The immediate result of the upheaval was to diminish the authority of a few of the lesser military governors and to increase that of the great provincial chieftains; but the latter showed no disposition to sink their individual ambitions in any common purpose of patriotism. The financial difficulties of the Government were seriously increased by the heavy claims advanced by the military leaders of the victorious Chihli party for payment of their troops, and it was not long before the native press began to denounce both the President and Chang Tso-lin as being even more dangerously subject to Japanese influence than the Anfu Club clique had been. A new combination and consolidation of power became manifested in Sept. 1920 by a matrimonial alliance concluded between the families of Chang Tso-lin and Tsao Kun, the two most powerful Tuchuns of the North; at the same time, there were signs of a *rapprochement* between these satraps and the followers of Tuan Chi-jiu, while the return to public life of Gen. Chang Hsun, under the protection of the President, gave currency to fresh rumours of a movement impending for the restoration of the throne.

At the end of 1920, the situation offered but little hope of relief for the sufferings of the Chinese people, continually harassed and plundered since the revolution by the undisciplined forces of semi-independent chieftains, whilst the general condition of the country reflected the increasing financial embarrassments of the Government. The defeat of the Anfu party and the emergence of a new group in control of the metropolitan administration, had produced no change in the situation; indeed it was evident that no improvements could take place so long as the Government continued to exist at the mercy of the military governors and compelled therefore to satisfy their rapacity at all costs. Even before the conclusion of the war in Europe, the Allied Powers had had occasion to observe the desperate nature of the expedients to which the Chinese Government was resorting in order to raise funds, and the truth had become generally recognized, not only abroad but by the mercantile class in China, that no financial or administrative panacea could produce a stable Government at Peking, unless accompanied by firm measures, taken under foreign supervision, for the disbandment of the provincial governors' military forces. In July 1918, the U.S. Government took the initiative of proposing the formation of a new four-Power financial Consortium. To this end a conference was held at Paris in May 1919, and after protracted negotiations between the Governments and financial groups concerned, an agreement was reached (Oct. 15<sup>1</sup> 1920) which provided for international coöperation between the United States, Great Britain, France and Japan in regard to the pooling of existing and future loan agreements with China. Under the scheme initiated at Washington it was proposed to make the disbandment of troops an essential condition of new loans; at the same time steps were taken to establish an international board for the abolition of "spheres of influence" and for merging all railway concessions into a comprehensive Chinese system, financed by the Consortium, wherein the principle of effective supervision would be observed. In the spring of 1921, however, the prospect of any general disbandment of the Tuchuns troops

<sup>1</sup> Blue Book, Miscell. No. 9 of 1921.

seemed as remote as ever; indeed, the forces of Chang Tso-lin and Tsao Kun had recently been considerably increased, and the opinion was gaining ground that something more forcible than financial coöperation would be required to achieve their disbandment and to reestablish the authority of the central Government at Peking.

*Authorities.*—Frederick Colman, *The Far East Unveiled* (1918); H. B. Morse, *The International Relations of the Chinese Empire*, vol. III. (1918); J. O. P. Bland, *Recent Events and Present Policies in China* (1912) and *China, Japan and Korea* (1921); Putnam Walsh, *The Fight for the Republic in China* (1918); H. M. Vinacke, *Modern Constitutional Development in China* (1920); *The China Year Book* (1919).

*Government and Administration.*—The establishment of the republic, following on the revolution of 1911, was proclaimed by Dr. Sun Yat-sen and his associates as a complete breach with the past and the substitution of a democratic form of government for China's ancient system of autocracy based on parental rule. Nevertheless, the history of the country, during the first ten years of the republic, and the methods of government practised by its new rulers, afford convincing proof of the abiding strength of the autocratic principle inseparable from Confucianism, ancestor worship and the family system. Reverence for this principle was unmistakably displayed at the outset, when the republican leaders, after the abdication of the Manchu, made formal obeisance at the shrine of the first Ming emperor (Feb. 15 1912) and ascribed their success to the protecting influence of his illustrious spirit. It was subsequently manifested in the "Articles of Generous Treatment," which pledged the Government of the republic to allow the Manchu emperor and his court to continue to reside in the imperial palace, with his retinue and imperial guards and a pension of 4 million taels per annum, and which made special provision for His Majesty's regular performance of the religious ceremonies at the ancestral shrines and mausolea. The administration of public affairs under the republic, whether by the "militarists" of the northern party, or the so-called constitutionalists of the South, has differed very little in essentials from that of the old régime; but new causes of unrest, inflicting much suffering upon the common people, have arisen from the elimination of the prestige and authority of the Throne. Neither the mandarins nor the masses have shown capacity to adapt themselves to democratic institutions.

In theory, the constitution under which the republic of China is governed is that which was drafted by the leaders of the revolution at Nanking in Nov. 1911 and formally promulgated in March 1912. It is admittedly a provisional constitution and has never yet possessed any effective force in determining either parliamentary or administrative procedure. Under its authority a Parliament was elected and convened. It met at Peking in March 1913, only to be suspended in Jan. 1914, by the President Dictator, Yuan Shih-k'ai, who thereafter until his death administered the Government in accordance with the accepted traditions of paternal despotism. Following upon the death of Yuan (June 1916) all the measures which, in the absence of Parliament, he had personally decreed, were pronounced null and void. The provisional constitution was reestablished as the foundation of law in the land, and the restored Parliament (Aug. 1916) proceeded to discuss at great length the provisions of a new and permanent constitution. But under pressure of the northern military chiefs, Parliament was again dissolved (June 1917) without having completed the draft. A new Parliament, elected under revised laws (specially devised for the occasion by the nominees of acting President Feng Kuo-chang), met at Peking in Aug. 1918 and elected Hsi Shih-chang to the presidency on Sept. 4. A number of members of the old Parliament, led by the southern Cantonese party, declared the new Parliament to be illegally constituted and its proceedings, including the election of the President, invalid. They declared their intention and their right to regard themselves as the sole legal legislative body in the State, and in that capacity established themselves, and a "Military Government," at Canton. In Aug. 1918, they appealed to the foreign Powers for recognition

and support on the plea, *inter alia*, that they were fighting "to make China safe for democracy." Tested by the terms of the provisional constitution, neither the Peking nor the Canton Parliament was a legal body, and the military Government of the South could have no claim to constituted authority. But whatever the legal aspects of the dispute, the result of this dissension in the ranks of the mandarin was to produce a chronic condition of civil war, or rather of widespread brigandage and unrest, throughout the country, and to nullify the efforts of the genuine progressives and patriots for securing reform.

Immediately after the revolution of 1911, the executive authority in each province was assumed by the local military commanders (Tuchus)—in most cases natives of the province. Generally speaking, the administration remained as before, in the hands of the bureaucracy, *minus* such control as the central Government had hitherto exercised. Under the dictatorship of Yuan (1913-6) that control was partially reestablished, and to a certain extent the provincial and local administrations became once more responsible, if not subject, to the central Government. In May 1913, President Yuan defined and promulgated by mandate the conditions under which the official systems of provinces, districts and circuits were to be administered, reestablishing the supreme authority of the civil, as opposed to the military, mandarin. The provincial assemblies were suppressed, and the position of district magistrates strengthened. But after the death of Yuan no further attempts at centralization of the Government were possible, and as the result of widespread disorders the administration passed rapidly from the civil to the military mandarins. The Tuchus (as the military governors came then to be called) gradually usurped all the important functions of administrative authority; and even in those provinces (*e.g.* Chihli and Kwangtung) where the civil governor has continued to function as the chief executive, his policy and proceedings have conformed generally to those of his military colleague. According to the provisions of the permanent constitution advocated by the southern parliamentarians, the provincial administration is to consist of a civil governor, a military governor, an intendant (the Taotai of the old régime), a district magistrate, and four heads of departments—general affairs, interior, education and commerce; but it is evident that, failing means to control the autocratic power of the military chieftains, no constitution can avail to secure uniformity of administration on these, or any other, lines.

As matters stand, the executive authority of the central Government is provisionally vested in a premier, nominated by the President, and a Cabinet of nine ministers, nominated by the premier. The Chinese names of the ministries have been changed since the abolition of the monarchy, but their general composition and functions remain practically the same. The nine ministries control respectively foreign affairs, home affairs, finance, army, navy, justice, education, commerce and communications. There are five subsidiary departments, dealing respectively with Mongolia and Tibet, railways, telegraphs, audit and customs, to most of the ministries' and departments a number of foreign advisers and technical experts have been attached.

*The Civil Service.*—Much of the political unrest and disorganization which have prevailed of recent years in China is ascribable to the suddenness with which the ancient system of classical examinations for the public service was abolished by the Manchu Government in 1906, and to the subsequent failure of the republican administration to replace it by any practical and authoritative scheme which shall ensure the continuity of the competitive principle. Under the new system of examination introduced in 1906 by order of the Empress Dowager, candidates for the civil service were required to display some knowledge of western science in addition to the Chinese classics. During the first four years of the republic, the system was even more rapidly modernized, the classics and philosophy being abandoned in favour of modern history, geography, law and science. But under the dictatorship of Yuan Shih-k'ai, this process was reversed and knowledge of the classics restored to its pride of place in the official curriculum. The general disorganization of public affairs and internal disorders prevalent since 1916 prevented the adoption of any comprehensive system applicable to, and accepted by, the whole nation; nevertheless, the holding of office remains the chief highroad to wealth and distinction in China, and the

number of aspirants to position under the Government is probably greater to-day than at any previous period in the history of the country. In those provinces where the authority of the central Government is recognized, the system now in force requires all candidates to be possessed of a diploma or high-school certificate. There are two classes of examination, one for those who aspire to important posts under the central Government and the other for clerkships and minor posts in the provinces. Under the republic the ancient rule which precluded mandarins from holding high offices in their native province, or for a period exceeding three years, has been abolished.

*Justice.*—Towards the close of the Manchu reign, with a view to removing the stigma of barbarism attaching to the Chinese administration of justice, and thus to inducing the consent of the Powers to the abolition of the foreign extra-territorial rights, the Chinese Government was advised to compile a provisional criminal code, abolishing the torture and flogging of prisoners and certain barbarous methods of inflicting the death penalty. This new code, based on the continental model, was promulgated in 1912, the first year of the republic; it embodied most of the legislation inspired by western ideals of humanitarianism. But like many other changes prescribed at this period from Peking, it remained without appreciable effect upon the administration of justice in the provincial *Yamens*, partly because the disordered condition of the country precluded any prospect of systematic reform in this direction, and partly because lack of funds prevented the provision of the courts, prisons, reformatories, and asylums which the code prescribed. It remained therefore to all intents and purposes a dead letter. Since then, the preparation of another new criminal code has been undertaken, part of which was published in 1918; and with the assistance of Japanese advisers, civil and communal codes have been drafted, providing for the imaginary needs of many non-existent conditions. The new system, as laid down in these codes, provides for officials with purely judiciary powers, for judges functioning respectively in the High Court of Justice at Peking, in provincial high courts, metropolitan courts and courts of First Instance, but generally speaking these judges and courts, like trial by jury and the scheme of prison reform promulgated by the Minister of Justice in 1912, have remained pious aspirations on paper, and must continue to be unattainable so long as the central Government lacks not only the authority but the men and the funds required to carry them into effect. According to a statement published by the Ministry of Justice in 1913, 689 new courts of justice had then been established and 13 model gaols provided; nevertheless, in most provinces the district officials remain, as before, charged with judicial functions, and the administration of justice, as far as the masses are concerned, is practically the same as that which obtained under the old régime. The widespread brigandage and continual struggles for supremacy between rival Tuchus, which became chronic conditions in most provinces after 1916, forbade all hope of effecting any general and permanent reform of the judicial system sufficient to justify the Chinese Government's aspirations in the matter of the abolition of extra-territoriality.

*Defence.*—As the result of the political disorganization prevailing since the death of Yuan Shih-k'ai, the Chinese army, as a national defence organization, practically ceased to exist, but the troops actually serving under one or other of the 22 Tuchus (military governors) are probably more numerous to-day than at any period of the Manchus' rule. The number of these irregular and undisciplined forces was estimated by Chu Chi-chien (northern delegate at the Shanghai peace conference in 1919) at 1,200,657 men of whom 540,344 were supposed to be under the orders of the central Government; but, as the result of the political conditions and the strife of factions at the capital, the majority of the forces stationed in the metropolitan province and in Manchuria owed their allegiance to their respective Tuchus, and even to the President in his individual capacity, rather than to the Ministry of War. In the words of a Chinese writer,<sup>1</sup> "the army has acquired provincial associations and lost its national character"; moreover, "in the absence of discipline among the inadequately paid troops, it is sometimes impossible to distinguish between the soldiers and the brigands whom they are expected to suppress." The inability of the central Government to collect its revenues from the provinces, and therewith to make due provision for the payment and control of a national army, has led to the creation of independent provincial forces, which have not only held the metropolitan administration to ransom, but levied tribute on the country at large. The disbandment of these forces is generally recognized in China to be a measure imperatively necessary, as a preliminary to the restoration of normal conditions.

*Finance.*—In Nov. 1912, prior to the conclusion of the organization loan of 1913, a board of audit was established at Peking, with foreign expert assistance, to audit the revenues and expenditures of the central and provincial Governments; nevertheless, the only reliable information available up to June 1921 on the subject of national finance were the published returns of the Inspectorate General of Customs and the revenue totals of the salt *gabelle*, collected under foreign supervision. The purely *pro forma* budgets,

<sup>1</sup> See S. G. Cheng, *Modern China*.

issued at irregular intervals by the Government since the establishment of the republic, have no demonstrable relation to the facts of the situation, and no good purpose would therefore be served by quoting their respective figures, or by attempting to draw any conclusions from them. It will be sufficient, as an example, to show the sources of revenue and headings of expenditure recorded in the budget for the fiscal year July 1916-June 1917 (which balance to a *tael*) as follows:—

REVENUE		EXPENDITURE	
I. Ordinary.		I. Ordinary.	
1. Land Tax.	\$ 90,105,784	1. Foreign Affairs	\$ 4,446,548
2. Customs.	73,056,663	2. Interior.	42,570,109
3. Salt <i>Gabelle</i> .	96,767,010	3. Finance.	61,792,970
4. Tax on Commodities including <i>Likin</i> .	42,719,194	4. War.	156,606,047
5. Regular and Miscellaneous Taxes.	34,768,432	5. Marine.	7,304,135
6. Regular and Miscellaneous Duties.	5,448,686	6. Justice.	9,337,156
7. Income from Investments.	2,083,401	7. Education.	4,433,893
8. Miscellaneous Income of Provinces.	5,101,531	8. Agriculture and Commerce.	2,734,790
9. Income of Central Administration.	1,374,648	9. Communications.	1,533,606
10. Income directly received by Central Government.	36,584,311	10. Mongolia and Tibet.	1,044,216
	<u>\$388,009,660</u>		<u>\$291,803,470</u>
II. Extraordinary.		II. Extraordinary.	
1. Land Tax.	\$ 5,751,464	1. Foreign Affairs	\$ 1,846,786
2. Customs.	706,885	2. Interior.	3,117,770
3. Tax on Commodities.	21,025	3. Finance.	162,397,633
4. Regular and Miscellaneous Duties.	3,911,410	4. War.	10,711,333
5. Income from Government Investments.	8,351	5. Marine.	847,434
6. Miscellaneous Income of Provinces.	91,610	6. Justice.	28,610
7. Income of Central Administration.	2,248,438	7. Education.	594,943
8. Income directly received by Central Government.	23,510,969	8. Agriculture and Commerce.	1,279,496
9. Miscellaneous Income of Central Government.	8,100,000	9. Communications.	116,833
10. Loans.	24,291,468	10. Mongolia and Tibet.	94,276
11. Advances from Banks.	16,187,305		
	<u>84,828,924</u>		<u>181,035,114</u>
Total Revenue	<u>\$472,838,584</u>	Total Expenditure	<u>\$472,838,584</u>

No budget was issued for the year July 1917-June 1918, a ministerial order having announced that the figures for the previous year would serve again. It is to be noted that the expenditure estimated under the heading of "Finance" includes the sum of \$142,244,888 allocated for the service and amortization of loans; also, that the receipts and expenditure under the heading of "Communications" do not include the returns of Government railways or posts and telegraphs.

*Customs Revenue.*—The revenues collected by the Maritime Customs for the years 1916-20 were as follows:

	Hk. Taels	Sterling	Average Exchange
1916	37,764,311	£ 6,193,347	38. 3/4d.
1917	38,189,429	8,244,541	4 3/4
1918	36,345,048	9,608,828	5 3/4
1919	46,009,160	14,566,000	6 4
1920	49,500,000	16,809,000	5 7/8

By an agreement concluded between the Allied Powers and China in the autumn of 1918, the import tariff was revised and new duties fixed at specific rates, calculated to produce an effective 5%

*ad valorem* levy. The Boxer indemnity payments were also suspended for a period of five years dating from Dec. 1, 1917.

The revenues reported to have been obtained from certain new taxes and dues, imposed by the Government since 1912, and included in the 1916-7 budget under the heading "Income directly received by Central Government," were as follows:—

Stamp Dues	\$ 5,864,400
Tobacco and Wine License Dues	2,012,852
Tobacco and Wine Tax	14,350,456
Income from Tobacco and Wine Sale	12,134,986
Mining Dues	2,221,617
	<u>\$36,584,311</u>

*Salt Gabelle.*—The steady growth of the revenue collected and paid into the Consortium banks by the salt *gabelle*, reorganized under foreign supervision, is shown by the following figures: 1914, \$60,409,676; 1917, \$70,627,249; 1918, \$71,589,603; 1919, \$80,636,503.

In May 1921, however, the *Tsines* correspondent at Peking reported that in several provinces the military governors, unable to extract funds from Peking for the upkeep of their troops, were commandeering the local salt revenues, thereby greatly reducing the surpluses heretofore available for the use of the central Government.

Whatever value the returns of provincial collections and remittances may have possessed under Yuan's dictatorship, as bases for future estimates, was completely nullified by the chaotic fiscal conditions which became chronic after 1916. Thereafter, the revenues of the central Government became confined to the surpluses of the Maritime Customs and salt *gabelle*, the profits of certain railways, and to loans; the last-named source of income consequently became that upon which the administration chiefly relied to maintain itself in power. From most of the provinces, none of the usual remittances to Peking were forthcoming; those Tutchuns of the North who still professed allegiance to the Government withheld their quota, generally on the ground that the disturbed condition of the country compelled them to devote all available revenues to the maintenance of their armed forces; in many cases they even demanded subsidies from the central Government as the price of their continued loyalty. Under these circumstances, the Government contrived to maintain its position by means of loans of all descriptions, most of them advanced by Japanese banks and industrial syndicates under conditions which have been severely criticized in China and abroad. At the end of 1918, the Japanese Government announced that, as further financial assistance to China would "add to the complications of her internal situation," no further loans by Japanese capitalists would be sanctioned. In 1919 and 1920, the financial difficulties of the Government became acute, in spite of the increased revenues of the customs and salt *gabelle* and the suspension of the Boxer indemnities; they were met by desperate measures, such as the sale to local banks of Internal Loans (1912) bonds at almost any price, the rapid issue of large blocks of Treasury bills, and short-term loans of every kind. In July 1918, recognizing the necessities of the situation, and desiring to "strengthen China and fit her for a more active part in the war against the Central European Powers," the U.S. Government took the initiative of organizing a new Four-Power Consortium, for the purpose of making loans to China. After protracted negotiations, the Consortium was established (Oct. 1920) by the British, French, American and Japanese financial groups, for the purpose of "procuring for the Chinese Government the capital necessary for a programme of economic reconstruction and improved communications"; but inasmuch as the disbandment of the greater part of the Tutchuns' military forces had been recognized as a preliminary condition, essential to the undertaking of this programme, no immediate solution of the problem from this quarter was to be expected. In Feb. 1921, at the "Chinese New Year" annual settlement of debts, the Peking administration only avoided a disastrous climax of insolvency by yielding to a demand by the associated Chinese banks for the consolidation of the Government's internal liabilities of loans, short-term debts and Treasury bills. The arrangement demanded by the banks involved the reorganization of certain revenues of the wine and tobacco monopoly, under foreign supervision and subject to the control of the inspector-general of customs, so as to provide for the regular service of the internal loans upon which amortization had been neglected. By virtue of this compact, the administration was enabled to meet its most urgent liabilities, but inasmuch as its ordinary income was henceforward diminished by the amount of the funds thus allocated, it was evident that, failing means to restore normal fiscal relations between Peking and the provinces, the situation must remain fraught with serious danger. The nature of this danger, and of the disorganization prevailing, was significantly manifested by the terms dictated to the President of the republic and to the Ministry of Finance, in May 1921, by the three most powerful Tutchuns of the North, involving the allocation of certain railway revenues for the maintenance of their increased and increasing forces.

*China's Indebtedness.*—At the end of 1916, the amount required to meet the service of China's officially stated foreign debts was

£10,800,000, that is to say, about 4½ millions more than the sterling equivalent of the Maritime Customs revenue at that date. Between 1917 and 1921, the Boxer indemnity payments having been suspended by the Allied Powers, and the sterling value of the customs and salt revenues more than doubled, the financial resources at the disposal of the Chinese Government were greater than at any previous period. No advantage was taken of this favourable opportunity of reducing the nation's foreign debt; on the contrary, it was materially increased by repeated borrowings from Japan, in the course of which many potential sources of national wealth were recklessly mortgaged. The amount of these loans, chiefly incurred by Premier Tuan's administration between 1916 and 1918, is not definitely known, for the details of several agreements have not been published, but it was estimated at over 200 million yen at the end of 1918. Little, if any, of the money thus raised was devoted to reproductive enterprises; it merely served to increase the numbers and rapacity of the Tuchuns' military forces.

The official "Statement of the Foreign Debts of China," issued by the Government Bureau of Economic Information in Jan. 1920, giving a list of loans and liabilities outstanding at that date, will be found on the following page.

The Bureau estimated the total of obligations outstanding as approximately \$657,627,083, but the rate at which exchange was calculated is not stated. (At the rate prevailing in Jan. 1921, the liability in dollars was practically double that of Jan. 1920.) Nor is it clear upon what basis this official statement was compiled, for it contains no reference to a number of railway and other loans, for which the Chinese Government is responsible, and its list of the advances obtained from Japan in recent years is evidently incomplete. The total amount of loans contracted for purposes of railway construction at the end of 1918 was about 40 millions sterling. According to a statement published by the *Peking Leader*, the total amount of foreign loans raised by the republican Government between 1912 and July 1918 was \$1,057,900,000, and new loans, to an aggregate of 230 million dollars, were under discussion.

**Currency Reform.**—In the commercial treaty concluded with Great Britain in 1902, China undertook to create a uniform national coinage. In 1908, the Government considered that the best solution of the matter would be a standard "tael," and orders were issued to the provincial authorities accordingly. In 1910, this plan was abandoned and a 72-candareen dollar was adopted as the standard national coin. In April 1911, an agreement was concluded between the Ministry of Finance and the Four-Power Consortium for a loan of 10 millions sterling, of which 8½ millions were to be used for the reform of the currency, but owing to the outbreak of the revolution, the loan was not floated. In 1912, the establishment of a gold standard was discussed, but in March 1914, the silver dollar was definitely adopted, and in 1915 coins bearing the effigy of Yuan Shih-k'ai were minted at Tientsin in large numbers; there had already been a considerable production of "standard" dollars by the mints at Nanking and Wuchang. A memorandum by the Minister of Finance in 1918 put the total coinage of new dollars (of 89% fineness) between 1914 and 1918 at 184 millions, against which 52 millions of old coins were withdrawn from circulation. The currency law promulgated in March 1914 was intended to secure a limited coinage of dollars and subsidiary decimal coins of fixed values. A code of regulations to this end was adopted by a currency commission advised by Dr. C. Vissering, but the Government authorities themselves failed to observe them and the output of the mints continued to be regulated by the necessities and opportunities of the officials concerned. The copper coinage, in particular, rapidly deteriorated. In Aug. 1918, the Minister of Finance (Tao Ju-lin) proposed the issue of gold currency notes and the establishment of a currency department under the direct control of the premier. The President endorsed the scheme by mandate, but the opposition was so strong that it was indefinitely postponed.

The chaotic conditions of the metal currency have been aggravated by the fact that numerous native banks and provincial Governments have issued bank-notes, in taels and dollars, for large amounts, uncontrolled and unsecured by bullion reserves, most of which circulate at varying rates of discount. (The Peking notes of the Bank of China and Bank of Communications were quoted at 50% discount in 1919.) During the revolution, moreover, military notes were indiscriminately issued, some of which the Government has since redeemed. The amount of provincial paper money in circulation at the end of 1917 was estimated at \$160,000,000. Many foreign banks having branches in China also issue bank-notes within the limits of their charters, which circulate freely in the treaty ports. The number of foreign banks doing business in China has greatly increased, the majority of the newcomers being Japanese and American. In 1921 the Native Bankers' Association at Shanghai was an organization of increasing influence; it restricts its membership to banks conducted on modern lines.

**AUTHORITIES.**—*China Year Book* (1919); T. W. Overlach's *Foreign Financial Control in China; The New Financial Consortium in China*, Blue Book, Misc. No. 9 (1921); C. Vissering, *On Chinese Currency*, 2 vols. (1912-4); H. B. Morse, *Trade and Administration of China*, 3rd ed. (1921); J. O. P. Bland, *China, Japan and Korea* (1921); and S. G. Cheng, *Modern China* (1920).

**Agricultural Products.**—The principal industry of China is agriculture, and its perpetual function is to produce the rice upon the supply of which staple food depends the survival rate of the population. Such new economic factors as the wide-spread revival of opium-growing (forbidden by imperial edicts and actively suppressed between 1907 and 1911), or the extension of the cotton-growing area due to the successful development of the spinning industry, necessarily involve a corresponding reduction of the home-grown food supply. These changes, unless accompanied by an increase of national wealth sufficient to replace it by purchases from abroad, must expose the nation to increased danger of famine in the years. According to the report on trade published by the statistical secretary of the Maritime Customs in April, 1920, the cultivation of the poppy had been regularly reduced to a wide scale in several provinces, notably Szechuan, Yunnan, Kweichow and Fukien. Between 1913 and 1920, the area under cotton cultivation steadily increased, in response to the growing demand of the spinning and weaving industries at Shanghai, Hankow, Tientsin and other industrial centres, the chief producing areas being Chihli, western Shantung, Honan, Hupeh, Kiangsi and Chekiang. The total production of raw cotton in 1919 was estimated at 12,000,000 piculs, a figure which placed China third on the list of cotton-producing countries. Simultaneously with these changes in the country's agricultural economics, all calculated to diminish the nation's home-grown food supplies, the extraordinary demand for rice and other foodstuffs in Japan and Siberia, which became acute in 1919, had resulted in a serious shortage of food in many parts of the country, before the bad harvest of 1920 produced a devastating famine in the northeastern provinces. In the summer of 1919, the Japanese competition for rice was so insistent that the south of China was deprived of its customary supplies from Indo-China and Burma; consequently, the staple food of the people rose to unprecedented prices. Other recent features of the agricultural economic situation are the rapid extension of the bean-growing area in Manchuria and the development of wheat cultivation (combined with a steady increase of the flour-milling industry) in N. China and the central Yangtze provinces. The statistics of the wheat and flour trades are particularly significant, illustrating on the one hand a change in the habits of the Chinese people in certain districts, and on the other, the increasing pressure which has been brought to bear upon China's resources by better organized or wealthier nations. In 1913, the total export of flour was 194,451 piculs; in 1919, it was 2,694,271 piculs, of which Japan and Siberia took each a third. In 1919, Japan and Siberia divided the wheat export amounting to 4,453,471 piculs; in 1913, the total export was 1,848,071 piculs. Similarly, the export of bean cake in 1919 was nearly 50% higher than in 1913, while that of bean cake rose by 75%. Japan being practically the sole importer of the latter. The manufacture of bean cake and bean oil has become one of China's most profitable industries.

**Mining.**—The mineral industry in China has advanced but little under the republic and remains, generally speaking, beset by the same difficulties and impediments as those which confronted the first Bureau of Mines in 1898. The fact is noteworthy, not only because of the nature and extent of the country's resources, but because of the seriously increasing financial obligations of its rulers. Under the Manchus, attempts were made to develop valuable mining areas by native enterprise under the direction of officials or merchants, or both combined, but without success. The foreign concession system, subsequently adopted, failed also to attain the desired end, for the reason that the central Government's authority, and even that of the provincial viceroys, was never sufficient to overcome the conservatism or the vested interests of the local officials and gentry. In many cases mining concessions granted to foreign capitalists under the monarchy were either repurchased or invalidated as the result of local opposition, and native mining continued to be conducted on the small-scale claim system and, generally speaking, by primitive methods. (In 1914 it was officially estimated that the amount of coal produced by 4,962 small mine owners was 6,315,000 tons.) No practical steps have been taken to fulfil the undertaking given in the Mackay Treaty (1902) that China would repay her mining rules "in such a way as to offer no impediment to the attraction of capital." The mining regulations issued in 1907, as the result of much pressure from the foreign ministers at Peking, were soon declared to be unworkable; they failed to make definite provision for the operations of large-scale mining by joint-stock companies. Thus, until and after the revolution, matters drifted. In 1913, inspired by a Minister of Commerce (Chang Chien) with some practical knowledge of modern industrial methods, the Government of the republic took up the subject again; the result was a bewildering mass of over 300 mining regulations, issued under seven headings, at various dates between March 1914 and July 1915. By this code the Government for the first time asserted the claim of the State to dispose of all mineral rights, and "no longer to allow landowners to hinder mining development"; at the same time, it reduced the hitherto exorbitant rate of direct taxation levied on the industry. But it still left the miners' produce exposed to export duties and transit taxes amounting to over 10%, in addition to property tax, land tax and output tax.

Name of Debt	Creditor	Amount borrowed	Amount outstanding	Borrowing date	Extinction date	Security
Russian-French loan . . .	Russia and France	fr.400,000,000	198,538,904	1895	1931	Customs Revenue
Anglo-German loan . . .	England and Germany	£16,000,000	8,665,797	1896	1932	Customs Revenue
2nd do. do. . . . .	England and Germany	£16,000,000	11,848,199	1898	1943	Customs Revenue
3 Arnhold Karberg loans . . .	Austria	£1,050,000	620,000	1912-3	1916-21	Peking Octroi & Title Deeds Tax
3 Austrian loans . . . . .	Austria	£3,700,000	2,467,000	1913-4	1917	Title Deeds Tax
Renewed Austrian loan . . .	Austria	£1,233,000	1,233,000	1915	1920	Title Deeds Tax
Crisp loan . . . . .	England	£5,000,000	5,000,000	1912	1952	Salt Revenue
Reorganization loan . . .	Five Nations Consortium	£25,000,000	25,000,000	1913	1960	Salt Revenue
Anglo Chinese Co. loan . . .	England	£375,000	375,000	1914	1934	Peking-Mukden Ry.
Industrial loan . . . . .	France	fr.100,000,000	100,000,000	1914	1964	Industrial Works & Wine Tax
Chin Yu loan . . . . .	France	fr.100,000,000	10,416,666	1914	1921	Treasury Bills
Koah Co. loan . . . . .	Japan	yen 5,000,000	4,500,000	1916	1919	Treasury Bills
Chicago Bank loan . . . . .	United States	\$5,500,000	5,500,000	1916	1921	Wine & Tobacco Tax
Japanese Group Bank loan . . .	Japan	yen 30,000,000	8,300,000	1917	1920	Salt Rev. & Treas. Bill
Telegraph loan . . . . .	Japan	yen 20,000,000	15,000,000	1918	1923	Teleg. Rev.
Ki Hui Rly. loan . . . . .	Japan	yen 10,000,000	10,000,000	1918	—	Treasy. Bills
Mine & Forest loan . . . . .	Japan	yen 30,000,000	30,000,000	1918	(renewed)	Mines & Forest Receipts
Participation loan . . . . .	Japan	yen 20,000,000	20,000,000	1918	1928	Treasy. Bills
Tsishun-Kaohsu Rly. loan . . .	Japan	yen 20,000,000	20,000,000	—	(renewed)	Treasy. Bills
Manchn. Mongoln. Rly. loan . . .	Japan	yen 20,000,000	20,000,000	—	—	Treasy. Bills
Pacific Develt. Corp. loan . . .	United States	\$5,500,000	5,500,000	1919	1921	Wine & Tobacco Tax
Boxer Indemnity . . . . .	England	£16,573,810	11,186,547	1901	1945	Customs & Salt Revs.
Boxer Indemnity . . . . .	America	\$53,348,145	12,455,507	1901	1945	Customs & Salt Revs.
Boxer Indemnity . . . . .	France	fr.580,160,035	391,581,529	1901	1945	Customs & Salt Revs.
Boxer Indemnity . . . . .	Italy	fr.217,868,647	147,051,159	1901	1945	Customs & Salt Revs.
Boxer Indemnity . . . . .	Russia	£42,685,163	30,759,683	1901	1945	Customs & Salt Revs.
Boxer Indemnity . . . . .	Japan	£11,391,703	7,531,985	1901	1945	Customs & Salt Revs.
Boxer Indemnity . . . . .	Belgium	fr.69,447,061	46,873,522	1901	1945	Customs & Salt Revs.
Boxer Indemnity . . . . .	Portugal	£30,203	20,387	1901	1945	Customs & Salt Revs.
Boxer Indemnity . . . . .	Spain	fr.1,107,596	690,068	1901	1945	Customs & Salt Revs.
Boxer Indemnity . . . . .	Holland	fr.3,066,005	1,910,191	1901	1945	Customs & Salt Revs.
Boxer Indemnity . . . . .	Sweden and Norway	£20,568	12,815	1901	1945	Customs & Salt Revs.

It was therefore not surprising that the new regulations failed to give any impetus either to mining exploration by foreigners or to new enterprise by native capitalists. In Jan. 1916, the Chinese Government resumed its study of the question; a new code of mining laws, framed on the Canadian model, was drawn up by a special commission under the chairmanship of the Minister of Commerce (Chou Tzu-chi), which included several highly qualified technical experts. It was intended to submit this new code for ratification by Parliament, but with the renewal of civil strife and the passing of Yuan Shih-kai, the question was indefinitely shelved. The unwillingness of Chinese officials under the republic to encourage extensive development of mining enterprise by means of foreign capital has evidently been inspired, as it was under the monarchy, by fear that the employment of foreign capital and experts is likely to produce the extension of foreign influence. The chief of the Chinese geological department (V. K. Ting), writing on the subject in May 1917,<sup>1</sup> declared that the chief obstacle to the rapid extension of mining operations by foreigners in China lies in the continuance of their claim to extra-territorial rights; that China cannot afford "to allow people who are outside Chinese jurisdiction to locate mining areas under the claim system." There is indispensible justification for the reluctance of the Chinese to grant to foreigners mining rights which may lead to political complications or involve the nation in loss of strategic or economic advantages. But the fact remains that, while preventing the extension of mining operations by foreigners in areas where no such considerations could arise, the rulers of China under the republic, either under pressure or in return for Japanese subsidies and loans, have parted with many mining rights of great national importance, in the Yangtze valley and in Manchuria.

The total production of coal in China was estimated in 1913 at 13,190,000 tons; two years later the estimate was 18,000,000 tons, of which 8,000,000 came from mines equipped with modern plant and the rest from small native workings. The amount of coal exported in 1918 was 1,708,149 tons; in 1919, it fell to 1,477,433 tons. The most important coal-producing enterprises are the Kailan Mining Administration (an Anglo-Chinese cooperative company) in Chihli and the Fushun mines (Japanese) in Manchuria, both of which are rapidly expanding. The principal metals which China has so far (1921) been able to produce in quantities sufficient for export are antimony, pig-iron, iron ore and copper. The trade in antimony was stimulated and the price advanced during the war, but in 1919 the demand had greatly diminished. The export of copper decreased greatly in 1918 and almost ceased in 1919, the amount produced being supplemented by the import of about 2,000 tons to meet the country's currency requirements. An important feature in the metal trade of 1919 was the increase in the export of iron ore from the Tayeh mines to Japan, the amount shipped being about 630,000 tons.

**Authorities.**—H. B. Morse, *Trade and Administration of China* (3rd ed., 1921); Montague Bell and Woodhead, *China Year Book* (1919-20); W. F. Collins, *Mineral Enterprise in China* (1918).

**Manufactures.**—Notwithstanding the generally disturbed condition of the country, a rapid advance took place in the development of industrial enterprises of all kinds during the first decade of the republic; so much so that, in his report on trade for 1919, the statistical secretary (Inspectorate General of Customs) observed that there were then few foreign type articles of domestic use that were not made in China by factories on modern lines, the majority of them without foreign assistance.

In 1906 there were 14 cotton-spinning mills in China, with a total of 400,000 spindles; in the *China Year Book* for 1919, the number given is 56 (excluding Hongkong) and the list of other mills, factories, etc., contained in the same volume covers 17 pages. With the shortage of raw materials, and the growth of labour troubles in Europe, Chinese capitalists (a class whose numbers and wealth rapidly increased under the Tuchen régime after 1916) and the rich merchants of the treaty ports came to realize after the war how great and lucrative are the opportunities awaiting the industrial development of China, with its vast resources of cheap labour and raw materials, in competition with the manufactures of the West. Japanese capitalists and captains of industry showed themselves equally alive to the possibilities of the situation. As a result, the development of industrial enterprises of many kinds, but especially in textiles, in the period immediately following upon the Armistice was limited only by the impossibility of obtaining the necessary machinery. The statistical secretary's list of articles (1919) manufactured in China includes silk and cotton clothing and underwear; toilet articles; umbrellas; woollen yarn; chemicals; needles; electric lamps; telephone appliances; wine and beer; asbestos articles and window glass. Shipbuilding has been established on a considerable scale at Shanghai and other treaty ports. During 1919 there were 12,307 tons of shipping launched from Chinese yards; in 1920, vessels were sent to Shanghai from England to have their woodwork and fittings completed by Chinese carpenters. Auxiliary to the establishment of native industries, a number of industrial banks were organized on foreign lines by the Chinese in 1919-20. As the result of a contract between the Chinese Government and the Marconi

Co., the construction of wireless telegraph stations was commenced in 1919; wireless telephony was also introduced by the Chinese National Wireless Co., using the Marconi patents; but it remains to be seen whether either these or aeroplanes can be made to serve any lasting purpose of public utility in China.

**Commerce.**—Amongst several noteworthy changes which occurred in the commerce of China during the period 1911-21, the most important were the elimination of the lawful traffic in imported opium; a considerable diversion of general trade from its former lines in favour of America (largely as a result of the World War), and the increasing production and consumption of domestic factory products of foreign type. Remarkable also, considering the disturbed political conditions prevailing, was the increase in the volume and value of China's trade during and after the war. The customs revenue for 1919 exceeded that for 1913 (previously the highest on record) by two million taels, and this despite the elimination of the revenue derived from opium and the very low rate of exchange at which *ad valorem* import duties were paid. In 1920, the record was again surpassed, the amount collected being Tls. 49,500,000 (equivalent at the average exchange of 5s. 7½d. to £16,809,000) which was 31 million taels more than in 1919. The value of the country's trade with foreign countries in 1919 increased by no less than 337 million taels, as compared with the year 1913. The advance was chiefly in exports and due to the imperious demand for foodstuffs and raw materials in Europe; for the first time, the value of China's exports practically balanced her imports. An indication of the prosperity resulting from this profitable activity in exports is to be found in the customs returns of the movements of treasure which show a net import into China of over 50 million taels' worth of gold and 92 million taels of silver during the years 1918-9. The growth of trade is also illustrated by the following figures, which show the sterling value, calculated at the average T.F. exchange for each year, of China's net imports and exports, exclusive of bullion:—

Net	1914	1915	1916
Imports . . . . .	£74,564,285	£58,939,819	£86,067,833
Exports . . . . .	£47,116,453	£4,321,069	£0,299,561
Net			
Imports . . . . .	£119,072,400	£145,658,383	£204,882,599
Exports . . . . .	110,301,853	127,544,295	199,758,331

*Note:* The exchange for 1918 was 5s. 3½d. and for 1919 6s. 4d. In 1920 the value of silver began to fall; the rate of exchange averaged 5s. 7½d.

The following statistics show the amount of China's direct trade with the foreign countries named, and afford an indication of some of the principal economic changes resulting from the war:—

	Imports		Exports	
	1913 Hk. Taels	1919 Hk. Taels	1913 Hk. Taels	1919 Hk. Taels
Great Britain	96,910,944	64,292,239	16,346,413	57,186,242
Germany . . . . .	28,302,403	368	17,025,224	163,886
France . . . . .	5,299,517	3,375,809	40,749,782	34,285,989
Japan	119,346,662	246,940,997	65,544,186	195,006,032
Russia (Overland trade).	12,228,180	1,724,603	3,695,826	5,516,517
U. S. A. . . . .	35,427,198	110,236,706	37,650,301	101,118,677
Hongkong (For transhipment)	171,366,099	133,631,544	117,128,661	131,495,296

The returns of shipping entered and cleared at Chinese ports during 1919 show comparatively little change during and since the war. The figures for the principal foreign nations concerned are as follows:—

Nationality	1913		1919	
	Vessels	Tonnage	Vessels	Tonnage
American . . . . .	2,458	898,750	4,433	2,569,887
British . . . . .	32,186	38,120,300	36,074	36,284,312
Norwegian . . . . .	637	739,328	311	302,959
German . . . . .	5,382	6,320,466	—	—
French . . . . .	1,020	1,232,763	—	414,161
Japanese . . . . .	22,716	23,422,487	27,182	27,532,449

The chief articles of import in 1919 were cotton goods, metals, kerosene oil, sugar, cigars and cigarettes, locomotives and railway cars, machinery, coal, fish, paper and motor-cars. The value of cotton goods imported was 30 million taels more than in 1913, but the weight of the goods was considerably less, a result partly due to high prices and partly to the increasingly effective competition of the products of Chinese mills. The total value of the latter products, passed through the customs for home consumption and export, was Tls. 92,698,787, as against Tls. 24,425,069 in 1913. In spite of the boycott, which remained in force during the greater part of 1919, the importations of Japanese shirtings showed a considerable increase over those of 1918. The following figures illustrate the position of the import trade for 1919, as compared with 1913, and reflect the growth of native industrial enterprise.

<sup>1</sup>See *North China Daily News*.



		1913	1919
Building materials	value Hk. Tls.	2,444,787	5,786,924
Cigarettes	"    "    "	6,209,037	7,771,947
Electrical materials	value Hk. Tls.	2,322,339	4,991,811
Machinery	"    "    "	4,650,001	14,100,439
Kerosene oil	gallons	183,984,052	199,309,753
Paper	value Hk. Tls.	7,169,255	10,212,652
Railway materials	"    "    "	4,317,694	3,883,239
Motor-cars and lorries	"    "    "	485,182	2,158,998

The sterling value of China's exports for 1919 was 228% higher than that of the pre-war record year 1913. In the order of their importance the chief articles of export are: silk (representing over 100 million taels), seed oils, bean cake, beans, cereals, raw cotton, skins and hides, seeds and seed cake, eggs, tea, metals, wool and sugar. The tea trade, though slightly better than in 1918, was less than half that of 1913, exports to Russia by sea having practically ceased and shipments to other countries being severely affected by the competition of Indian and Ceylon teas. With a view to stimulating the trade, the Chinese Government abolished the export duty, and reduced the *lithin* by half for two years from Oct. 1919. The silk trade reflected the increased purchasing-power of the United States and the growing popularity of silk fabrics in America.

Out of the total of 131,506 piculs exported, the United States took 36,028 in direct shipments, as against 23,772 piculs shipped direct to France, 16,819 to British India, and 2,297 to Great Britain. Of Chinese cotton shipped abroad (1,072,000 piculs), nine-tenths was bought by Japan and the remainder by the United States. These countries were also the principal buyers of China's seed oils, wood oil and skins and hides.

*Work of Reference.*—C. A. Middleton Smith, *The British in China and Far Eastern Trade*.

*Waterways.*—In Dec. 1913 a National Conservancy Bureau was established, under the presidency of the progressive Minister of Commerce, Chang Chien, with Mr. Van der Veen as consulting engineer, to deal with irrigation and river conservancy matters. The conservancy of the Hwai river, with a view to the prevention of floods in Kiangsu and Anhui, received special attention. In July 1914, this river was surveyed by engineers sent to China by the American Red Cross; their investigations were followed by an agreement between the American International Corporation and the Chinese Government for a conservancy scheme, to be carried out under the direction of the Grand Canal Improvement Board. As the cost of the proposed work, involving the construction of a great dam and a new subsidiary canal, necessitated the raising of a loan, the scheme was perforce postponed upon the outbreak of the World War, pending facilities for raising the funds required.

*Railways.*—The outbreak of war and the impossibility of raising further foreign loans, resulted in the suspension of several enterprises, projected and commenced. Several important agreements had been concluded by the Chinese Government in 1913 and 1914 for the construction of new lines; these were compelled to await the restoration of conditions favourable for financing these undertakings abroad. The railways for which preliminary or final agreements were thus concluded, included the following:—

Tatung to Chengtu (Franco-Belgian capital); approximately 960 m. This line forms part of a general scheme intended to provide through communication between French Indo-China and Kalgan, connecting at Tatung with the Peking-Kalgan railway extension, with the Hukuang system, and with a French line to Yunnanfu, Yanchow (near Pakhoi) to Yunnanfu, and thence to Chungking (French capital); about 1,000 m.

Sinyang to Pukou (British capital). This is the final agreement (Nov. 14 1913) for a concession originally granted in 1898. Length of line, about 275 m.

Shasi to Singyi (British capital), a "construction" contract (Dec. 18 1913) for about 800 m., through Changtsefu and Kuci.

Nanking to Hunan (British capital), about 1,000 m. of line, via Ningkuo and Nanchang to Pingsiang.

In addition to these, agreements were made by the Chinese Government with the German and Japanese Governments respectively for the construction of a number of railways in Shantung and Manchuria and Mongolia. (In Oct. 1917, the Industrial Bank of Japan issued a loan of 50 million yen for the building of these lines, including two of the ex-German railway concessions in Shantung.) Two other important railway agreements were made by the Chinese Government during the war, namely, one (March 1916) with the Russo-Asiatic Bank, for a Chinese Government railway from Harbin to Aigun, with several branch lines, and another (May 1916), with an American syndicate, for the construction of a number of proposed railways, aggregating 1,100 miles.

Coincident with the Government's adoption of the programme of active construction indicated by these concessions, the policy was definitely adopted of centralizing control of the various provincial railway systems and unifying their accounts and methods of management. A commission was appointed for the purpose in 1913, under the presidency of Tih Kung-Chao (Minister of Communications, 1920) with the assistance of an American adviser. On Jan. 1 1915, the unified methods came into operation, with the result that

the annual reports on Chinese Government railways, subsequently published by the Ministry of Communications, afford a comprehensive statement of the financial and general situation. The following figures are taken from the Ministry's report for the year ending Dec. 31 1919:—

The total length of railway lines in China at the beginning of 1920 was 6,819 m. (10,963 km.), consisting of Government and "Concessioned" railways, as follows:—

	Km.	Km.
<b>Government Railways.</b>		
In operation		6,027
Operation by construction forces:—		
Lung Hai	368	
Hupeh-Hunan	15	383
<b>Total Government Railways</b>		<b>6,410</b>
<b>Provincial and Private Railways.</b>		
Kwangtung	225	
Kiukiang-Nanchang	136	
Sunning	171	
Swatow-Chaochowfu	42	
Nanking City	11	
Chung Hsing Mining Co.	52	
Liu Hsiang Coal Mine	12	
Tayeh Mining Co.	30	
Ching Hsing Mining Co.	15	
Kailan Mining Administration	26	
Taikaoku Mines	19	
Tsitsihar City	29	
Ma Chiapu Narrow Gauge	5	773
<b>Total subject to control of the Ministry of Communications</b>		<b>7,183</b>
<b>Concessioned Railways.</b>		
Chinese Eastern	1,722	
South Manchurian	1,107	
Shantung	451	
Yunnan	465	
Canton Kowloon (British Section)	35	3,780
<b>Total kilometres of railway in China (Miles 6,813)</b>		<b>10,963</b>

Excluding the dependencies (Mongolia, Turkestan and Tibet) China has about 276 sq. m. of territory and 54,000 inhabitants to each mile of railway, as against 40 sq. m. and 8,600 in India.

The Ministry's report showed a surplus of \$36,449,392 on the working of the Government lines for the year 1919, an increase of \$2,944,272 as compared with 1918. The profits per kilometre earned by the principal lines varied very considerably. The profit per kilometre on the Peking-Mukden railway was \$10,234; on the Peking-Hankow \$9,678; on the Cheng-Tai, \$4,664; on the Kaileng-Honan, \$3,937; on the Shanghai-Nanking, \$3,288, and on the Tientsin-Pukou, \$2,848. On Dec. 31 1919 the accumulated surplus of the combined Government lines, as shown by the Ministry's accounts, was over \$63,000,000 of which sum \$36,000,000 consisted of additions to property, 21 millions funded debt retired, and cash on hand over 22 millions (of the last amount 2½ millions consisted of the notes of the Peking branches of the Bank of Communications and Bank of China, then circulating at about 50% of their face value). The net revenues of railways under the Ministry's control increased by 64% between 1915 and 1919; it is, however, typical of Chinese official finance that, after showing such excellent results, the Government should have been unwilling or unable to purchase the rolling stock required for a section of the Hankow-Canton line (costing \$2,000,000) without having recourse to a new foreign loan.

*Telegraphs.*—In 1912 the head office of the Chinese Telegraph Administration, until then located at Shanghai, was transferred to the Telegraphic Bureau of the Ministry of Communications at Peking and a uniform scale of charges was introduced. In 1915, the total length of lines in operation was 42,518 m., with 710 stations. The rates in force (increased in 1920 in aid of the famine relief fund) are high, and messages in foreign languages are charged 50% more than those in Chinese. At the high silver exchange prevailing in 1919-20, the rate for telegrams in English was roughly equivalent to 6d. a word for messages in the same province, and 1s. a word to other parts of China. A few foreigners (Daves) are still employed in the administration and a Danish adviser is attached to the telegraph departments of the Ministry at Peking. Wireless stations had (1921) been installed at Peking, Kalgan, Hankow, Nanking, Shanghai and Canton, but their service was restricted to Government messages. In Oct. 1918, a contract was made by the Government with the Marconi Co. for the installation of three wireless stations at Kashgar, Urumchi and Lanchowfu, to communicate with a connecting station at Sianfu.

*Posts.*—The postal service of China, originally organized as a branch of the Imperial Maritime Customs, was separated from that administration and placed under the Ministry of Communications in May 1911. Under the republic it has remained a department of that Ministry, but responsible for its own budget and organization. Since 1911 the department has been controlled by a Chinese director general and a French associate director. Its activities extend

not only over the eighteen provinces, but throughout the New Dominion and Manchuria.

The growth of its progressive development and usefulness has been remarkable, in spite of the disturbed conditions and brigandage prevalent throughout most parts of the country since the revolution. During the three years 1916-8, after the death of Yuan Shih-k'ai, postal operations and extensions in many provinces were seriously hampered by the depredations of bandits and lawless soldiery. In Shensi alone, 78 post-offices were looted in 1918. Nevertheless, in that year the number of district offices and agencies had increased to 9,367 (as compared with 5,357 in 1910) employing 27,000 Chinese, with a foreign staff of about 110. The growth of the service is shown by the following figures:—

	1908	1913	1918
Mail matter posted . . .	79,882,252	197,484,136	302,269,028
Parcels . . . . .	623,315	1,380,912	2,738,090

Money orders increased from ten million dollars in 1913 to thirty-five millions in 1918. The earnings of the department in 1918 were \$9,500,000 and showed a profit of \$1,910,000 over working expenses, as compared with a surplus of \$303,000 in 1915. China joined the Postal Union in 1914. On March 1, 1917 an agreement was concluded with Great Britain for the direct exchange of postal parcels, and later in the same year a similar arrangement was made with the Russian postal administration for parcels crossing the Russo-Chinese frontier. In 1921 the Treaty Powers still maintained their own post-offices in many places for the despatch and receipt of mails from overseas, and in certain instances the operations of these extra-territorialized establishments, especially in the matter of the parcels post, had worked to the detriment of China's postal service and inland revenues. The number of post-offices maintained by the Powers in 1921 was as follows: Great Britain, 11; France, 15; Japan, 21 in China proper and 23 in Manchuria; Germany (before the war), 17; Russia (before the war), 28; United States, 1. (J. O. P. B.)

**CHIROPRACTIC**, the name given to a method of healing employed in the United States, based on the theory that most disease is the result of displacement of the vertebrae of the spinal column, resulting in abnormal pressure upon the nerves as they emerge. It is held that the articular joints are frequently thrown out of alignment, it may be only in slight degree, and the constricted nerves are thereby prevented from transmitting to the various bodily organs the mental impulse necessary for proper functioning. The human body has been charted, and it is claimed that the nerves emanating above each vertebra regulate particular organs; hence the cause of different diseases can as a rule be readily localized. Health is possible only when all the organs function harmoniously, and disease of one organ may affect some other. The chiropractor attempts to find the subluxated joint, and with the bared hand to adjust it. He never resorts to drugs or surgery; he merely tries to relieve the impinged nerve and leaves the rest to nature.

The first reported healing by chiropractic was made in 1895, when Dr. D. D. Palmer (b. near Toronto, Canada, March 7 1845; d. at Los Angeles, Cal., Oct. 13 1913), a "magnetic healer," in Iowa treated a man who had been deaf for 17 years. He claimed to have discovered that a displaced vertebra was pinching a certain nerve and that its adjustment was quickly followed by complete restoration of hearing. Little was done to work out a theory in detail until 1909, when Dr. B. J. Palmer (b. Sept. 10 1881), a son of the discoverer, began its formulation, resulting in the development of a well-defined system of articular adjustment with the hands. He established the Palmer School of Chiropractic ("Chiropractic Fountain Head") at Davenport, Ia., which remained the best known, although later many others were founded in different parts of the United States. The course of study extends over three collegiate years of six months each, and the subjects studied correspond with those of the usual medical school, *materia medica* alone being ignored. In 1921 there were about 10,000 chiropractors to be found in some 30 of the United States. In several states they were still debarred from practice, and in others legislation was pending.

**CHISHOLM, HUGH** (1866—), editor of the *Encyclopaedia Britannica*, was born in London Feb. 22 1866, of Scottish descent. His father, HENRY WILLIAMS CHISHOLM (see 25,772), was the son of Henry Chisholm (1769-1832)—private secretary and librarian for many years to Lord Grenville (auditor of the Exchequer: Prime Minister 1806-7), by whom he was given a clerkship in the Exchequer, eventually becoming senior clerk in the Exchequer Bill Office and King's Agent for Sierra Leone and the

<sup>1</sup> A set of the 9th ed. and supplement of the *Encyclopaedia Britannica*, inherited by his son and grandson, was purchased by him out of the allowance made for "stationery" to clerks of the Exchequer in those days—a form of perquisite in addition to salary.

Gold Coast—whose paternal grandfather had left Inverness-shire and settled in London early in the 18th century. Henry Williams Chisholm (1809-1901) entered the Exchequer in 1824 with a nomination from Lord Grenville, rising to be head of its official staff in 1862 as chief clerk; and on the abolition of the Exchequer in 1866 as a Government department coordinate with the Treasury, he was appointed, under the Weights and Measures Act (1867), head of the newly created Standards Department of the Board of Trade, occupying the old Exchequer office at 7, Old Palace Yard, Westminster, with the official title of Warden of the Standards. At the Exchequer he had become a recognized authority on public finance; and his "Great Account" (see 10,58), published in 1869 as a Parliamentary Return in 3 vols., dealing in detail with the history—unrecorded till then—of the public revenue and expenditure of Great Britain and Ireland since 1688, and of the origins of the whole British fiscal system, was the outcome of 10 years' laborious research. As Warden of the Standards he was the British delegate to the International Metric Commission at Paris from 1870 to 1875, and took a leading part, as a member of its permanent scientific committee, in preparing and constructing the newly adopted international standards. At the desire of the Government, his retirement from office was postponed for this purpose till the end of 1876, when he had been 52 years in the public service. His "Recollections of an Octogenarian Civil Servant" were published in *Temple Bar* (Jan. to April 1891).

Educated at Felsted school, and at Oxford (as a scholar of Corpus, Hugh Chisholm graduated in 1888 with a first class in *Literae Humaniores*, and then read for the bar, being "called" at the Middle Temple in 1891; but he had already then drifted into London journalism. From 1892 to 1897 he was assistant-editor, and from 1897 to the end of 1899 editor, of the *St. James's Gazette* (see 19,561); and during these years he also contributed numerous articles on political, financial and literary subjects to the weekly journals and monthly reviews, becoming well known as a literary critic and Conservative publicist. On resigning the editorship of the *St. James's*, he became a leader-writer for the *Standard*, and later in 1900 was invited to join *The Times*, under whose management he acted as the responsible co-editor, with Sir Donald Mackenzie Wallace and President Hadley of Yale University, of the new volumes, constituting the 10th ed. (1902), of the *Encyclopaedia Britannica*. In 1903 he was appointed editor-in-chief of the 11th ed., which was completed under his direction in 1910, and published as a whole by the Cambridge University Press, in 29 vols., in 1911. He subsequently planned and edited the *Britannica Year-book* (1913). Rejoining *The Times* in 1913 as day-editor, and a director of *The Times* Publishing Co., he became financial editor at the end of that year, and occupied this responsible position all through the momentous period of the World War, resigning his connexion with *The Times* in March 1920 in order to reassume the editorship of the *Encyclopaedia Britannica* and to organize the publication of the New Volumes constituting the 12th edition.

**CHOATE, JOSEPH HODGES** (1832-1917), American lawyer and diplomat (see 6,258), died in New York May 14 1917. Upon the outbreak of the World War he ardently supported the cause of the Allies. He severely criticized President Wilson's hesitation to recommend America's immediate coöperation, but shortly before his death retracted his criticism. He was chairman of the mayor's committee in New York for entertaining the British and French commissions in 1917. His death was hastened by the physical strain of his constant activities in this connexion. Among his last works were *Abraham Lincoln and Other Addresses in England* (1910) and *American Addresses* (1911). See Edward Sandford Martin, *The Life of Joseph Hodges Choate* (1920).

**CHRISTIAN SCIENCE** (see 6,291).—In 1910 the total number of Christian Science churches was 1,201 (1,077 in the United States, 58 in England, 38 in Canada, 28 elsewhere); on Jan. 1 1920 the number was 1,804 (1,590 in the United States, 98 in England, 46 in Canada, 70 elsewhere). As a Christian Science church invariably has two readers, the one to read the Bible,

the other to read the text-book (Science and Health with Key to the Scriptures), the number of readers in 1910 was 1,402 and in 1920 was 3,608. Statistics of membership are never issued officially; and in 1921 there was nothing later on the subject than the *Report on Religious Bodies*, published in 1908 by the U. S. Bureau of the Census, showing in the United States in 1906 85,717 members, of whom about 72% were women.

After the death in 1910 of Mary Baker Eddy, the founder and director of the denomination, the board appointed by her became the governing body of the church. Mrs. Eddy's estate, amounting to \$2,500,000, was left for the promotion of Christian Science, and in 1914 the trustees announced that the income would be used in providing lectures, in distributing authorized literature throughout the world, in establishing libraries in connexion with churches, societies, and reading-rooms, and, so far as possible, in helping towards the erection of church buildings. Upon the outbreak of the World War in 1914 the Christian Science churches in Paris organized relief activities for war sufferers, and at the end of the year the board of directors of the Mother Church (the First Church of Christ, Scientist, in Boston, Mass.) appointed a War Relief Committee. Funds were raised from their own members and distributed through authorized representatives in the warring countries; up to May 31 1917 the total receipts for relief work were \$310,700 of which \$264,400 had been forwarded for distribution. In 1917, after the entrance of the United States into the war, a Camp Welfare Committee was appointed, over 100 welfare rooms were opened in the United States, Canada and Great Britain, and approximately \$50,000 expended on buildings and equipment. More than 2,000 persons served without compensation as camp welfare workers and in other capacities. The denomination had nine chaplains in the army and one in the navy. The total amount raised for war work approximated \$2,000,000.

The decade 1910-20 witnessed considerable dissension within the church. In 1909 the board of directors of the Mother Church in Boston expelled from the church Mrs. Augusta E. Stetson, who since 1890 had been pastor of the First Church of Christ, Scientist, of New York City. It was charged that Mrs. Stetson was using her influence to insure her succession to the headship of the denomination after Mrs. Eddy's death. This was denied by Mrs. Stetson, who in turn charged the directors with promoting a false and materialistic interpretation of Mrs. Eddy's writings. Although defended by a large number of followers, she quietly resigned her New York pastorage. In 1913 she published her side of the case in *Reminiscences, Sermons and Correspondence Proving Adherence to the Principle of Christian Science as Taught by Mary Baker Eddy*. In 1919 a serious dispute arose between the trustees of the Christian Science Publishing Society and the board of directors of the Mother Church. The trustees claimed that the board aimed to create an oligarchy, and was trying to usurp their powers. They denied that they were under the jurisdiction of the board, which, in turn, claimed supreme authority. Through counsel (among whom was Charles E. Hughes) the trustees secured in 1919 a temporary injunction, restraining the board from interfering with the trustees of the publication society. At first the courts seemed to support the contention of the trustees; the majority of the churches apparently sided with the directors. Several cases were reported in which persons associated with the trustees' publications were forbidden by churches to teach in Sunday-schools. The injunction was set aside Nov. 23 1921.

In 1921 the church was issuing the following periodicals: *The Christian Science Quarterly Bible Lessons*; *The Christian Science Journal*, a monthly; *Der Herold der Christian Science*, a monthly, with pages alternately in English and German; *Le Héraut de Christian Science*, a monthly, with pages alternately in English and French; *The Christian Science Sentinel*, a weekly; and *The Christian Science Monitor*, an excellent international daily, published in Boston.

**CHRYSTAL, GEORGE** (1851-1911), British mathematician, was born near Aberdeen March 8 1851. He was second wrangler at Cambridge in 1875, and was appointed successively professor of mathematics at St. Andrews in 1877 and at Edinburgh in

1879, holding the latter post till his death. He was the author of a standard treatise on algebra as well as of many publications on physical and mathematical subjects, and his researches into the surface oscillations of Scottish lakes won him a Royal medal from the Royal Society. He died at Edinburgh Nov. 3 1911.

**CHURCH, ALFRED JOHN** (1829-1912), English classical scholar, was born in London, Jan. 29 1829. Educated at King's College, London, and Lincoln College, Oxford, he took holy orders and was assistant-master at Merchant Taylors' school for many years. He was professor of Latin at University College, London, from 1880-8 and, in partnership with W. J. Brodribb, translated Tacitus and edited Pliny's Letters; but he is best known by his English re-telling of classical tales and legends for young people (*Stories from Virgil*, *Stories from Homer*, etc.). He wrote much Latin and English verse, and in 1908 published his *Memories of Men and Books*. He died at Richmond, Surrey, April 27 1912.

**CHURCHILL, WINSTON** (1871- ), American writer, was born in St. Louis, Nov. 10 1871. He graduated from the U. S. Naval Academy in 1894. He was conspicuous alike in scholarship and in general student activities. He became an expert fencer and he organized at Annapolis the first eight-oared crew, of which he was for two years captain. He had already decided upon a literary career, and after brief service in the navy he resigned and for a time was connected with the *Army and Navy Journal*. In 1895 he became managing editor of the *Cosmopolitan Magazine*; but in less than a year he retired that he might have more time for writing. His first novel, after being twice recast, appeared as *The Celebrity*, in 1898. His next book, *Richard Carvel*, appeared in 1899 and had a sale of almost a million copies. Its scene is Maryland during the American Revolution. His next work, *The Crisis* (1901), opens in St. Louis in the days of the Civil War. The heroine is the great-great-granddaughter of his former hero, Richard Carvel. The intervening period of western expansion, following the Louisiana Purchase, is depicted in *The Crossing* (1904). His other works are: *Coniston* (1906, the career of a post-bellum political boss); *Mr. Crewe's Career* (1908, the railroads in politics); *A Modern Chronicle* (1910); *The Inside of the Cup* (1913, the 20th-century Church); *A Far Country* (1915, methods of "big business"); and *The Dwelling Place of Light* (1917). All his novels treat of phases of American development, historical or social, and form a sort of chronological sequence. He has written a play in three acts, *Dr. Jonathan* (1919). Mr. Churchill took an active part in state politics. From 1903 to 1905 he was a member of the Legislature of New Hampshire, and in 1912 he was an unsuccessful candidate for governor on the Progressive ticket.

**CHURCHILL, WINSTON LEONARD SPENCER** (1874- ), English statesman (see 6,347). Mr. Churchill's tenure of the presidency of the Board of Trade, from April 1908, was marked by the production of a scheme in the autumn of that year for the settling up of a court of arbitration in labour disputes, consisting of three persons nominated by the Board, respectively from panels of employers, workmen and "persons of eminence and impartiality." He also welcomed on behalf of the Government an Eight Hours Miners bill. In 1910 he was promoted to the Home Office. Here he had to deal with the dangers arising from the increasing hordes of undesirable aliens who poured into the East End of London. He was present in person at an extraordinary affray in Sidney St., Mile End Road, on Jan. 3 1911, when the police, after a time reinforced by soldiers, were kept at bay for many hours by two foreign burglars who defended themselves in a house with Mauser pistols, and who ultimately perished when the building caught fire and was burnt.

In the autumn of 1911, to the surprise of the public, an exchange of offices was effected between him and Mr. McKenna, and he became First Lord of the Admiralty. Hitherto he had been wont to pose as a disbeliever in the German menace, and an advocate of reductions in British armaments. In Aug. 1908, for instance, he rebuked Lord Cromer for uttering grave words of warning, and ridiculed the bare possibility of an Anglo-German conflict in arms. Early in 1909 he had assisted Mr. Lloyd George in the Cabinet in his unsuccessful endeavour to cut down Mr.

McKenna's estimates. But the Agadir crisis of July 1911 seems to have opened his eyes as it did those of Mr. Lloyd George. At any rate, he spoke at Guildhall on Lord Mayor's Day in a worthy manner; admitting that the growth of the German navy was a main factor in British construction, and pointing out that no power was better able to bear the strain or less likely to fail than Great Britain. Similarly at Glasgow in Feb. 1912 he submitted that naval power to the Germans was a luxury; it was existence to the English, it was expansion to them. "We shall face the future as our ancestors would have faced it, without disquiet, without arrogance, but in solid and inflexible determination." He had in the previous month announced the establishment of a naval war staff, and in the autumn he reorganized the internal administration of his office. The same tone was maintained in his speech on introducing the naval estimates. If any one nation, he said, were able to back the strongest fleet with an overwhelming army, the whole world would be in jeopardy. Great Britain must never conduct her affairs so that the navy of any one power could engage her at any moment with a reasonable prospect of success. He announced a complete reorganization of the navy, which was to be grouped in four fleets, three being for home defence, based on home ports (the third being the Atlantic fleet previously based on Gibraltar), and the fourth, based on Gibraltar, to operate either in home waters or in the Mediterranean. The significance of this new orientation was at once perceived. It was hailed with satisfaction by the Unionists, but the pure economists complained that he had thrown sobriety and thrift to the winds. These changes were mainly due to the inspiration of Lord Fisher, and of Sir Arthur Wilson, Lord Fisher's successor as First Sea Lord. There was a slight decline of £300,000 in the total of these estimates; but this was merely a pause after the £12,000,000 increase of the past three years; and by the summer a new German navy law necessitated a supplementary estimate of about a million. In 1913 there was a further increase of about a million and a quarter. Once more a supplementary estimate, largely due to aircraft development, added two millions and a half; and in 1914 Mr. Churchill introduced the highest estimates hitherto on record, £51,550,000—an increase on the total of 1913 of some two millions and three-quarters. He grasped, moreover, at an early date the vital importance of oil fuel, and forwarded eagerly the arrangement by which oil was to be obtained for the navy from Persia. Meanwhile, he had thrown out, on the estimates of 1913, a hint to Germany that all naval Powers might well take a year's holiday from shipbuilding; but, though he repeated and emphasized his plea for this "naval holiday" in a speech in the autumn of 1913, it met with no response from Berlin. Large as the estimate for 1914 was, it was attacked by naval experts as inadequate.

There would perhaps have been more general satisfaction with the results of Mr. Churchill's undoubtedly energetic and patriotic administration at the Admiralty, if he had not shown himself so vehement a partisan in internal politics. But he was in the van of controversy over the Parliament bill, over Home Rule, and especially over the Ulster resistance. "Full steam ahead" was his motto for his party in the turbulent session of 1911. In Feb. 1912 he made a daring incursion into Ulster, in order to advocate Home Rule at Belfast; but he was wise enough to give up his original intention of making the Ulster Hall, with its Orange and Protestant associations, the scene of his meeting, and also to represent the Government plan as an integral part of parliamentary devolution. He developed this line of argument when moving the second reading of the Home Rule bill in April, and at Dundee in the autumn outlined a general policy under which England would be cut up into self-governing areas. But both in the House and at Dundee he emphatically declared that Ulster, though she had a claim to special treatment, must not be allowed to bar the way. Next year he declared at Dundee in Oct. that, if a single province could interpose a "bully's veto," constitutional and peaceful agitation would be discredited throughout the British Empire and the civilized world. But the speech which most exasperated his political opponents was one which he delivered at Bradford in March 1914, just after

the incident of the Curragh. Against any attempt in action to subvert parliamentary government, there was no lawful measure, he said, from which ministers would or could shrink. If British civil and parliamentary systems were to be brought to the challenge of force, he could only say "Let us go forward together and put these grave matters to the proof." His dispositions of naval forces in the Irish Channel were bitterly resented by the Unionists, who accused him of being in a "plot" to provoke Ulster to armed resistance and then coerce her. In return, he described these accusations as "a vote of censure by the criminal classes on the police," and averred that the measures taken were purely precautionary.

These controversies were stilled by the war. Here Mr. Churchill showed that he appreciated the situation better than the majority of his colleagues. On Monday, July 20, at Spithead, there was a great review by the King of the most powerful fleet ever assembled, numbering some 200 vessels in all, manned by 70,000 officers and men. While the ships were still engaged in tactical exercises, Austria's ultimatum to Serbia was issued (July 23) and the 12 anxious days which culminated in the World War began. In the ordinary course the fleet would have been demobilized at the close of the week; but with the outlook so disturbed, the First Lord and the First Sea Lord (Prince Louis of Battenberg, afterwards Lord Milford Haven) took the responsibility of keeping it on a war footing, ready for action. Hence, when the rupture occurred, the fleet was already at its stations in the North Sea, and Adml. Jellicoe was promptly appointed commander-in-chief. The Expeditionary Force was conveyed across the Channel in perfect safety, and its communications safeguarded; and the German mercantile marine was soon cleared from the seas. But there were some naval disasters for which the public were not prepared. The German battle cruiser "Goeben" eluded the British Mediterranean fleet and got safely into the Sea of Marmora; three British cruisers were sunk by submarines in the North Sea; and a British squadron under Adml. Cradock was heavily defeated by a German squadron off the coast of Chile; Prince Louis of Battenberg, a most patriotic and capable sailor, unjustly attacked because of his German origin, tendered his resignation as First Sea Lord, and Mr. Churchill put in his place the indefatigable veteran, Lord Fisher. Meanwhile Mr. Churchill heartened his countrymen by patriotic speeches at a non-party meeting in the London Opera House in Sept., and at Guildhall in November. He rushed to Antwerp when there were hopes of saving it from the Germans, but though he exerted himself indefatigably both in diplomacy and in the actual work of defence, and sent a British naval division to help, the effort was in vain. When a war council was formed on Nov. 25, he was one of the original members and, along with the Prime Minister and Lord Kitchener, bore the main responsibility. The naval situation was sensibly relieved by the destruction in Dec. by Adml. Sturdee, off the Falkland Islands, of the German squadron which had defeated Cradock, and by a successful action under Adml. Beatty in Feb. 1915 off the Dogger Bank. On the other hand, German sporadic attacks by sea and air on British watering places and the increasing activity of German submarines gave Mr. Churchill and the Admiralty much concern. He determined to treat prisoners captured from submarines, in view of their breaches of the laws of war, with more severity than ordinary prisoners; but the Germans retaliated harshly on the most noteworthy English prisoners in their hands, and Mr. Balfour, on succeeding Mr. Churchill, gave up this discrimination. But Mr. Churchill's great coup in the war was the attack on the Dardanelles, which he pressed forward in spite of the increasing reluctance of Lord Fisher. The idea was a captivating one, and an appeal from the Russians for help in that quarter was difficult to resist. It is arguable, and he was disposed to maintain, that the movement would have succeeded if resolutely pushed by those in command, both in the initial stage, when it was a purely naval attack, and in the later stage, when considerable military forces had been landed and fought many desperate fights. But, in fact, it failed; and the friction engendered between the First Lord and the First Sea Lord was one of the causes which drove

Mr. Asquith to invite the Unionists in May to join in a Coalition Government. A change at the Admiralty was imperative. Mr. Churchill had shown enormous vigour, industry, imagination and patriotism; but insufficient judgment and discretion. He was transferred to the sinecure office of the Duchy of Lancaster, but held it only till Nov., when, on the appointment of a small war committee of the Cabinet from which he was excluded, he resigned, being unwilling to accept a position of general responsibility for war policy if he had no effective control. He placed himself at the disposal of the military authorities and was sent to France as a major in the Grenadier Guards. He was accordingly little seen in Parliament for the next year or more, though he was in his place to criticize the navy estimates of his successor Mr. Balfour, to reproach him for want of energy, and to recommend the recall of Lord Fisher.

The report of the Dardanelles commission, which was published in March 1917, confirmed the view of the public that some of the blame for that mismanaged enterprise rightly attached to Mr. Churchill. It was therefore with surprise and some disapproval that people found Mr. Lloyd George, who appreciated his powers, admitting him into his Government in July 1917 as Minister of Munitions, a post in which he did good work for a year and a half, but did not come specially before the public. After the war, however, when Mr. Lloyd George reconstructed his Government, he became Secretary of State both for War and for Air, a conjunction of offices which was much criticized. As War Minister he had the gigantic task of demobilizing armies of between four and five millions who had been in the war, of providing armies of occupation and forces for immediate garrisoning of the Empire, of building up an after-war army, and of re-creating the territorial army. He made considerable progress in the following two years, but he was greatly criticized for the size of his estimates, and especially for the large forces retained in Mesopotamia and Palestine. On Lord Milner's retirement in the spring of 1921 he succeeded him as Secretary of State for the Colonies; and a new arrangement was made by which the responsibility for Mesopotamia and Palestine was taken over by the Colonial Office. Mr. Churchill went out to Egypt, and held in Cairo a conference of the British civil and military officers then administering those countries. On his return, he outlined to Parliament a scheme by which the cost might be greatly reduced, mainly through the transference of authority to Arab chiefs.

He and his wife had a son and three daughters. His mother, Lady Randolph Churchill, divorced her second husband, George Cornwallis-West, in 1913; and married in 1918, as her third husband, Mountague Phippen Porch, formerly a Government official in Nigeria. She died June 29 1921. (G. E. B.)

**CHURCH HISTORY** (see 6.330).—(1.) **CHURCH OF ENGLAND** (see 9.442). The most important event in the Anglican Communion in the decade 1910-20 was the sixth Lambeth Conference, held at Lambeth Palace under the presidency of the Archbishop of Canterbury from July 5 to Aug. 7 1920. There were present 252 bishops, as compared with 76 out of the then total of 144 at the first gathering in 1867. These Conferences claim no conciliar or legislative authority, *i.e.* it is left to the various branches of the Church throughout the world to act upon their decisions or recommendations, in whole or in part, or to ignore them altogether. Their claim is to present a consensus of Anglican opinion upon subjects vitally affecting the welfare of the Church and the world, and to set forth, so far as diverse conditions may admit, general principles of action. The subjects considered at the Conference of 1920, in the order in which they are arranged in the Encyclical Letter wherein the bishops set forth their conclusions, were: the reunion of Christendom, the ministry of women, Spiritualism, Christian Science and Theosophy, problems of marriage, the Church and industrial problems, international relations, missionary problems and the development of ecclesiastical provinces.

*Reunion of Christendom.*—By far the most momentous of these subjects is the re-establishment of the broken unity of the universal Church, and in relation thereto the Conference put out an "Appeal to all Christian people." This document rec-

ognizes that "the causes of division lie deep in the past, and not by no means simple or wholly blameworthy," but insists that the time has come for "a new outlook and new measures," and for "reaching out towards the goal of a reunited Catholic Church." The essentials of visible unity are defined as the acceptance of the Scriptures as the ultimate standard of faith and of the Nicene Creed as the sufficient statement of that faith, of the sacraments of Baptism and the Holy Communion, and of "a ministry acknowledged by every part of the Church as possessing not only the inward call of the Spirit, but also the commission of Christ and the authority of the whole body." On this last-named crucial point, upon which the real difficulty of reunion turns, the bishops say:—

"May we not reasonably claim that the Episcopate is the one means of providing such a ministry? It is not that we call in question for a moment the spiritual reality of the ministries of those Communions which do not possess the Episcopate. On the contrary we thankfully acknowledge that these ministries have been manifestly blessed and owned by the Holy Spirit as effective means of grace. But we submit that considerations alike of history and of present experience justify the claim which we make on behalf of the Episcopate. Moreover, we would urge that it is now, and will prove to be in the future, the best instrument for maintaining the unity and continuity of the Church. But we greatly desire that the office of a Bishop should be everywhere exercised in a representative and constitutional manner, and more truly express all that ought to be involved for the life of the Christian Family in the title of Father-in-God."

By way of practical suggestion the Appeal goes on to say:—

"If the authorities of other Communions should so desire, we are persuaded that, terms of union having been otherwise satisfactorily adjusted, Bishops and clergy of our Communion would willingly accept from these authorities a form of commission or recognition which would commend our ministry to their congregations, as having its place in the one family life. . . . It is our hope that the same motives would lead ministers who have not received it to accept a commission through episcopal ordination, in obtaining for them a ministry throughout the whole fellowship."

The resolutions, of which the Appeal formed part, recommended that the Churches of the Anglican Communion should invite conference with other religious bodies concerning the possibility of taking definite steps to cooperate in a common endeavour on these lines to restore unity. In the committee's report it was suggested that authority might be given to bishops to permit ministers not episcopally ordained to preach in churches within their dioceses and to their own clergy to preach in the churches of such ministers, and "in the few years between the initiation and the completion of a definite scheme of union," to admit to Communion baptized but unconfirmed communicants of the non-episcopal congregations concerned. The bishops, however, disapproved of "general schemes of inter-communication or exchange of pulpits." It was expressly stated that these decisions were "all but unanimous." In further pursuance of the desire for reunion the Conference approved of Anglican bishops taking part in the consecration of Swedish bishops, being satisfied that those bishops possess the Apostolic succession, and on Sept. 19 1920 the bishops of Durham and Peterborough joined in the consecration of the Swedish bishops of Visby and Vesterås. Both before and after the Conference rapid progress was made towards a better understanding between the Church of England and the Orthodox Eastern churches.

*Ministry of Women.*—The committee of the Conference was of opinion that there is nothing to prevent the belief that the Apostolic commission recorded in St. John xx. 19-23 was delivered to women as well as to men, and dealing with the disciplinary directions of St. Paul as to the subordination of women in the churches, declared that:—"To transfer with slavish literalness the Apostle's injunctions to our own time and to all parts of our own world, would be to renounce alike our inalienable responsibility of judgment and the liberty wherewith Christ has made us free." The bishops went on to lay down the conditions for the constitutional restoration of the ancient Order of Deaconesses. For some sixty years past there have been Anglican deaconesses, but save in the United States, where they are formally recognized, they have derived their

authority less from the several Churches of that Communion than from individual bishops. Upon her ordination a deaconess will acquire Holy Orders, conferred according to a "form and manner, such as might fitly be included in the Ordinal." The functions of deaconesses are defined as:—"(a) To prepare candidates for Baptism and Confirmation. (b) To assist at the administration of Holy Baptism, and to be the administrant of that Sacrament in cases of necessity in virtue of her office. (c) To pray with and to give counsel to such women as desire help in difficulties and perplexities. (d) With the approval of the bishops and of the parish priest, and under such conditions as shall from time to time be laid down by the bishop (i.) in church to read Morning and Evening Prayer and the Litany except such portions as are assigned to the priest only; (ii.) in church also to lead in prayer and, under licence of the bishop, to instruct and exhort the congregation." It should, however, be pointed out that Clause (d) (ii.) was passed by a majority only. Women other than deaconesses should have opportunity given them, with the bishop's permission, to speak and lead in prayer both in consecrated and unconsecrated buildings at other than the regular and appointed services of the Church, on the same conditions as men.

*Spiritualism, Christian Science, and Theosophy.*—The Conference saw "grave dangers in the tendency to make a religion of Spiritualism," the practice of which as a cult "involves the subordination of the intelligence and the will to unknown forces or personalities." The teaching of Christian Science "cannot be reconciled with the fundamental truths of the Christian faith and the teaching of Scripture," since it tends to Pantheistic doctrine, to a false antithesis between spirit and matter, and to the denial of the reality of sin, disease and suffering. The Conference declared that in the positive teaching of Theosophy there are cardinal elements irreconcilable with the faith.

*Marriage and Sexual Morality.*—"The Conference affirms as our Lord's principle and standard of marriage a life-long and indissoluble union, for better for worse, of one man with one woman, to the exclusion of all others on either side, and calls on all Christian people to maintain and bear witness to this standard. Nevertheless, the Conference admits the right of a national or regional Church within our Communion to deal with cases which fall within the exception mentioned in the record of our Lord's words in St. Matthew's Gospel, under provisions which such Church may lay down." "Grave concern" is expressed at "the spread in modern society of theories and practices hostile to the family," such as the use of unnatural means for the avoidance of conception. In regard to venereal disease, "the Conference must condemn the distribution or use, before exposure to infection, of so-called prophylactics, since these cannot but be regarded as an invitation to vice."

*The Church and Industrial Questions.*—"An outstanding and pressing duty of the Church is to convince its members of the necessity of nothing less than a fundamental change in the spirit and working of our economic life. This change can only be effected by accepting as the basis of industrial relations the principle of co-operation in service for the common good in place of unrestricted competition for private or sectional advantage."

*Christianity and International Relations.*—Stress was laid upon the importance of endeavouring to increase international comity and good-will, and of securing their expression by an increased recognition of international law and custom. Steps should immediately be taken to enable the whole Church of Christ to urge upon the peoples of the world the principles of the League of Nations. "We hold that the peace of the world, no less than Christian principle, demands the admission of Germany and other nations into the League of Nations at the earliest moment which the conditions render possible."

*Missionary Problems.*—It was urged by the Conference that missionary societies and boards should make their work centre in the Church rather than in the mission organization by the establishment of councils and diocesan boards, which should have a real share in financial control and general direction. Liturgical uniformity should not be regarded as a necessity

everywhere, *i.e.* the Prayer Book, as the one fixed liturgical model, is inapplicable in many parts of the mission field. It is sufficient that local liturgical forms should retain "those features which are essential to the safeguarding of the unity of the Anglian Communion."

*Development of Provinces.*—The gradual creation of new ecclesiastical provinces should be encouraged, and each newly-founded diocese should as soon as possible become a constituent member of a province. In the opinion of the Conference four is the minimum number of dioceses to form a province, but no number is too great so long as convenience of consultation is assured. Newly-constituted provinces should have some distinct voice in the elections of their metropolitans.

*Self-Government of the Church.*—The need of a representative body which, by including laymen, should interpret to the nation the desires of churchpeople and make clear the need for self-government with greater force than was possible to the Houses of Convocation, had been felt in the Church of England for many years. After much discussion and considerable opposition a Representative Church Council was formed in 1904 and endowed with a constitution in the following year. It consisted of the four Houses of Convocation and the two Houses of Laymen. The council, however, had no legal existence and no powers save such as were accorded to it by the good-will of churchpeople. It served a useful temporary purpose and encouraged the growing conviction that the laity were entitled to a much larger share in the councils of the Church, but its lack of authority made it an imperfect instrument, and it soon became clear that nothing short of a statutory body would satisfy the insistent claim for lessened State control. In 1913, therefore, a committee was appointed by the two archbishops "to inquire what changes are advisable in order to secure in the relations of Church and State a fuller expression of the spiritual independence of the Church as well as of the national recognition of religion." This committee unanimously reported that Parliament, owing to modern changes in its memberships, was no longer the right legislative authority for the Church, and that the time was ripe for granting to the Church wider powers of self-government, and presented a scheme for enabling statutory form to be given to four elective bodies, *i.e.* parochial church councils, diocesan conferences, diocesan conferences, and a Church council. As we have seen, the germ of the last named already existed in the Representative Church Council. The other three bodies were also in voluntary existence, although the number of parochial church councils was relatively small. In 1917 the scheme was accepted in principle by both Convocations, and in 1919 a further committee appointed by the Representative Church Council presented an amended plan which was finally adopted with one dissentient. In May of that year the Convocations addressed the Crown, asking that legislative authority should be conferred upon the proposed Assembly, and on Dec. 23 1919 the Church of England Assembly (Powers) Act according this authority received the Royal Assent. For this result the active propaganda conducted by the Life and Liberty Movement was largely responsible. The Assembly consists of the whole of the diocesan bishops of England (the House of Bishops), the whole of the members of the two Lower Houses of Convocation (the House of Clergy), and a number of laymen and laywomen proportioned to the size of each diocese, elected for five years by the diocesan conferences (the House of Laity). The three Houses may sit together or separately. Under the Church of England Assembly (Powers) Act (commonly called the Enabling Act), the first two duties of the Assembly were to draw up a constitution for the parochial councils and to take steps for the reform of Convocation.

The Assembly, which met for the first time on June 30 1920, was empowered to legislate by means of bills (technically called Measures) which, after being passed by it, are to be sent to an ecclesiastical committee consisting of 15 members of the House of Lords, appointed by the Lord Chancellor, and 25 members of the House of Commons, appointed by the Speaker. This committee is to consider each measure, and "draft a report



thereon to His Majesty, stating the nature and legal effect of the measure, and their views as to its expediency, especially with relation to the constitutional rights of all His Majesty's subjects." If the report is favourable the Measure will go before Parliament, but will not be presented for the Royal Assent until each House has asked for it.

*Parochial Church Councils.*—Under the Parochial Church Councils (Powers) Measure, which received the Royal Assent in 1921, a church council is to be formed in every parish, elected by the registered parishioners or non-resident attendants at the parish church. The electors, male or female, must be 18 years of age, and have been baptized, and must subscribe a declaration that they are not members of any religious body out of communion with the Church of England. To these councils most of the powers of the churchwardens have been transferred; they will be responsible for raising and spending money for parochial purposes, and they are charged to cooperate with the incumbent in all matters concerning the welfare of the parish.

*Ruridecanal Conferences.*—These are elected by the parochial church meetings from their own members. In most cases they elect the members of the Diocesan Conferences.

*Diocesan Conferences.*—In their turn the Diocesan Conferences elect the lay members of the Church Assembly in given proportions for each diocese. They form also the financial and business authority of the diocese, to which all the immovable Church property within their area must be legally transferred. To them are affiliated the Boards of Finance which are to act as the collecting and spending authorities of the dioceses.

*Reform of Convocation.*—In Nov. 1920, the Church Assembly performed its first legislative act by passing a Measure declaring that the Convocations have power, with the Royal Assent, to make canons for the amendment of their constitution. This assent having been given, the Convocations, in Feb. 1921, drew up new constitutions which made the following provisions: The Upper Houses will consist, as now, of all the English diocesan bishops; the Lower Houses will consist of all the deans, including those of Westminster and St. George's, Windsor, the two senior archdeacons in each diocese, one proctor for every hundred electors, with one more for every incomplete hundred not being less than fifty; the electors will be all clergymen benefited in the diocese, or possessing the bishop's licence, or holding office in a cathedral or collegiate church; all clergymen in priest's orders will be eligible for election as proctors; the voting is to be on the lines of proportional representation.

*Prayer Book Revision.*—The revision of the Prayer Book authorized by the Royal Letters of Business first issued in 1906, and since renewed, to the two Convocations enjoining them to consider "the desirability and the form and contents of a new rubric regulating the vesture of the ministers of the Church at the times of their ministrations, and also of any modification of the existing law relating to the conduct of divine service, and to the ornaments and fittings of churches," had in 1920 been completed subject to the assent of the National Assembly of the Church. The proceedings were necessarily slow and complicated, since each of the four Houses of Convocation had to debate every proposal in detail. Many of the emendations were merely verbal; others raised questions the most sharply controverted between sections of opinion in the Church.

*The Athanasian Creed.*—One of the sharpest controversies raged around the Athanasian Creed, of which a new translation, prepared at the request of the Archbishop of Canterbury, was published in 1917. After prolonged discussion it has been decided by both Convocations that the Creed shall be retained in the Prayer Book, without the existing rubric, and with a new rubric prescribing that on Trinity Sunday it may be said in place of the Apostles' Creed.

*The Holy Communion.*—The revision permits the priest to celebrate in a surplice or in "a white alb plain with a vestment or cope." He is to say the service "in a distinct and audible voice." The Commandments are shortened: thus the tenth reads simply, "Thou shalt not covet." They may be omitted altogether at a given service provided that they are said once

every Sunday. The collects for the king are omitted; the reader of the Epistle and Gospel is to turn towards the people; the sermon is permissive; ceremonial mixing of the chalice is permitted, in the Exhortation the words "eat and drink our own damnation" are corrected to "eat and drink judgment unto ourselves." An altered Proper Preface is provided for Whitsuntide and several new Proper Prefaces are inserted. In the Canterbury revision only the Canon is rearranged; the Prayer of Humble Access following immediately after the Comfortable Words, and the Lord's Prayer following the Prayer of Consecration. The latter is lengthened by the addition of thanksgiving and prayer. Of the Prayers of Oblation and Thanksgiving, one or both may be said. The words of Administration may be said once "to the whole number" of communicants, either the first or the second, half of the words being recited to the individual, or the whole words may be said once to each faithful of communicants instead of saying them to each separately. A declaration is added to the effect that the Order of Holy Communion ought not to be diminished or added to, "nor should the private devotions of the minister be such as to hinder, interrupt, or alter the course of the service." The Convocation of York concurs in these emendations, with the exception of the amended Canon.

*The Psalter and the Lectionary.*—In the main the revision of the Prayer Book Psalter has consisted of the emendation of unintelligible, misleading or obscure phrases, archaic punctuation, and the discarding of words which have changed their meaning or fallen into disuse, such, for instance, as "leasing" for which "lying" is substituted. As regards the recitation of the Psalter, Psalms are appointed for every Sunday in the year and for certain Holy Days. Otherwise the Psalms, with a few omissions, will be read through in order once a month. Psalms have also been selected for use on various occasions instead of those for the day, but others may be substituted with the approval of the bishop. Certain Psalms and portions of others are discarded altogether from public reading. Coming to the Lectionary, we find that alternative first and second Lessons have been provided for Sundays. To make it possible for congregations to hear selections from the less familiar parts of the Old Testament and from some Books of the Apocrypha, alternatives have been chosen to the Lessons taken from the Pentateuch, the Historical Books, and the Book of Proverbs. Two series of Second Lessons have been provided, one from the Gospels and the other from the Acts, the Epistles, or the Book of Revelation. The First Lessons for week-days follow a coherent plan—the principle of the arrangement of the Second week-day Lessons is that when a Lesson from the Gospels is read at Matins, one from the Acts, Epistles, or Revelation should be read at Evensong, or vice versa. Special Lessons have been provided for Holy Week, Easter Week, Rogation Days, Whitsun Week, Holy Days, and Dec. 29, 30 and 31. It is recommended that Lessons should be prefaced by a brief Introduction.

*The New Calendar.*—A new calendar has been prepared, to which have been added, among others, Saints Polycarp, John Chrysostom, Thomas Aquinas, Patrick, Cuthbert of Lindisfarne, Leo the Great, Anselm, Catherine of Siena, Athanasius, Basil, Bernard of Clairvaux, Aidan, Ninian, Francis of Assisi and Clement of Alexandria. All Souls' Day is added, and the Saints, Doctors and Martyrs of the Church on Nov. 8.

*Other Provisions.*—Alternative Epistles and Gospels are provided for Christmas Day and Easter Day, and collects for St. Mary Magdalene, the Transfiguration, the Nativity of the Blessed Virgin Mary, All Saints' Day, Harvest Thanksgiving and Saints' Days in the Calendar not otherwise provided for. In the Exhortation in the Marriage Service the second of the causes for which matrimony was ordained now reads "that the natural instincts and affections, implanted by God, should be hallowed and controlled." In the Lesson in the Burial Service (1 Cor. xv.), verses 27 to 34 inclusive are omitted and an alternative Lesson is provided from 2 Cor. iv. 16-v. 21, "Though our outward man," etc. In the Ordinal an important alteration has been made in the Questions to Deacons as to their belief in

**Holy Scripture.** It now runs: "Do you unfeignedly believe all the Canonical Scriptures of the Old and New Testaments as given of God to convey to us in many parts and in divers manners the Revelation of Himself which is fulfilled in our Lord Jesus Christ?"

**The Scottish Revision.**—The Church in Scotland has also revised its Prayer Book, and a tentative revision is now in use. In 1910 the Episcopal Synod prepared a revised Scottish Communion Office, and in the same year the Consultative Council on Church Legislation prepared a schedule of permissive additions to and deviations from the Book of Common Prayer. The new and revised forms were finally sanctioned and came into operation in a permissive form in 1912. In the Communion Office, according to both the Scottish and the English rite, either of which may be used in Scotland, the Commandments may be omitted and replaced by Our Lord's Summary of the Law. The collects for the King may also be omitted. When there are many communicants the words of administration may be said once, the first half of the words only being recited to each person. The mixed chalice and reservation for the sick are authorized by rubric. New Proper Prefaces have been provided for festivals which hitherto lacked them and new collects, Epistles and Gospels for marriages, funerals and other special occasions and for certain festivals. There is now power, with the bishop's consent, to omit the Litany altogether on the three great festivals. Certain portions may be omitted at other times; new suffrages have, however, been added for the king's forces, for missions, and for Parliament. A variety of additional prayers have been added, together with commemorations of the dead. In the Marriage Service the exhortation has been altered and abbreviated, and there are alternative Lessons in the Burial Service. In the Confirmation Service the sign of the cross may be used. Considerable difficulty was experienced in preparing a revised Psalter which should be generally acceptable, but in 1915 a committee appointed by the Scottish bishops produced a new distribution of the Psalms, which is now in permissive use. Its distinct feature is the provision of separate Sunday and week-day courses. The Sunday course allows of the recitation of the whole, with the exception of some of the minatory Psalms, once a year; the week-day cycle is completed every 28 days. A new Lectionary which prescribes Proper Lessons for the eve of festivals and other special occasions, and makes larger use of the Apocrypha, was adopted in 1918. A committee appointed in 1918 by the Consultative Council on Church Legislation to consider further revision of the Prayer Book reported in June 1921, and the Council agreed that a complete new Scottish Prayer Book should be published.

**Church Reunion.**—The movement which rendered possible the "Appeal" put forth by the Lambeth Conference began definitely in 1910 when the General Convention of the American Episcopal Church resolved unanimously to invite the Christian Communions all over the world to hold a World Conference "for the consideration of questions touching Faith and Order." The World War seriously delayed progress, though much was done to clear the ground. A committee representing the Church of England and the Free Churches produced two interim reports containing a statement of agreement on matters of faith, and a similar statement regarding order, the latter of which accepted the Sacraments of Baptism and the Lord's Supper and recognized that there had been conferred upon "the whole Church" "a ministry of manifold gifts and functions." The questions upon which differences still remained in 1921 were how far the visible society involves uniformity or allows variety in policy, creed, and worship, the conditions, objective and subjective, in the ministration of the Sacraments upon which their validity depends, and whether the ministry derives its authority through an episcopal or a presbyterial succession, or through the community of believers, or by a combination of them. The second interim report recognized that continuity with the historic episcopate should be preserved, but that the episcopate ought to resume a constitutional form. The acceptance of the fact only of episcopacy should be expected, theories as to its character

being set aside. "The acceptance of episcopacy on these terms should not involve any Christian community in the necessity of disowning its past, but should enable all to witness and influence as heirs and trustees of types of Christian thought, life, and order not only of value to themselves, but to the Church as a whole." A meeting preliminary to the Conference was held at Geneva in Aug. 1920 at which 40 countries and 70 religious communions were represented, and a Continuation Committee was appointed to make further preparations for the World Conference on Faith and Order. The date of the Conference had not been fixed in June 1921, but the Patriarch of Jerusalem had invited it to meet in the Holy City. Meanwhile there was much domestic discussion on the subject of reunion. The propriety of the exchange of pulpits between ministers of the Church of England and of the Free Churches was hotly debated, but such exchanges were frequently taking place. The most remarkable instances occurred when a Baptist minister preached in Canterbury cathedral on the occasion of a war anniversary, and Dr. Jowett (Congregationalist) preached in Durham cathedral, in each case at the invitation of the dean. In 1919 the Bishop of London formulated a scheme for reunion with the Wesleyan Methodists, the main features of which were that the Wesleyan Church should be a society within the Church; that a certain number of presidents and superintendents should be consecrated bishops, and that ordinations in each Church should be in a form which would satisfy the other. No practical result has yet followed. A conference of Churchmen and Nonconformists at Mansfield College, Oxford, resolved in favour of interchange of pulpits, mutual admission to the Holy Communion, and "acceptance by ministers, serving in any one denomination, who may desire it, of such authorization as shall enable them to minister fully and freely in the churches of other denominations." The Federal Council of the Evangelical Free Churches has expressed a desire to discuss with representatives of the Anglican Communion the proposals of the Lambeth Conference for the avoidance of misunderstandings.

**Reform of Church Finance.**—The chaotic condition of the finances of the Church of England, the overlapping and waste of effort resulting from innumerable more or less isolated endeavours to accomplish a given end, the existence of many societies with aims and policies of their own, led in 1909 to the appointment of the Archbishops' Committee on Church Finance. After more than two years' inquiry and deliberation this Committee reported in 1911, and its recommendations were subsequently carried into effect. The keynote of the report was the recommendation that the diocese and not the parish should be the unit of Church life and that responsibility for the work of the Church should be brought home to every member. There is now a Board of Finance in every diocese elected by and affiliated to the Diocesan Conference. These boards arrange a system for the assessment of every parish according to its means and population. There is a Central Incorporated Board of Finance, a Committee of Maintenance of the Clergy and a Central Advisory Council on Training for the Ministry. These general provisions include arrangements present or prospective for recruiting and training ordination candidates who are unable in whole or in part to provide the cost of their own education; for maintaining the ministry by the endowment and augmentation of benefices, etc.; for the provision of clergy pensions; for providing for the widows and children of the clergy and making grants to clergy in difficulties through misfortune; for the erection of new churches and other parochial buildings, and the repair of those already existing. The most noteworthy result is that the Church of England now possesses, for the first time in its history, a legal corporate existence. A bequest of money to "The Church of England" is now valid and effective; previous to these important rearrangements it would have been void, since under English law no one was entitled to give a receipt on behalf of the Church as a corporate body. So soon as it was in working order (in the autumn of 1918) the Central Board of Finance began an attempt to raise a central fund of £5,000,000 for the maintenance of the clergy,

the education of ordination candidates, training colleges and other Church purposes. In 1919 a sum of £120,000 was allocated to the pecuniary assistance of the clergy, but in 1920 only £30,000 was available for this purpose, the progress of the central fund having been disappointingly slow; most, if not all, of the dioceses have failed to raise their quotas. The Board has established an Ordination Test School at Knutsford, for testing the vocation of candidates for the ministry who had served in the war, and down to the end of 1920 about 700 men were sent there, while a somewhat similar number were helped to go to the universities and theological colleges. The school was in 1921 being used mainly for civilian candidates. The Central Board of Finance, whose methods have been seriously criticised, is henceforward to be responsible to the Church Assembly.

*Welsh Church Commission.*—The Royal Commission appointed in 1906 to "inquire into the origin, nature, amount and application of the temporalities, endowments and other properties of the Church of England in Wales and Monmouthshire, and into the provision made and work done by the Churches of all denominations in Wales and Monmouthshire for the spiritual welfare of the people and the extent to which the people avail themselves of such provision," did not report until Dec. 1910. The statistics presented on behalf of the Church showed that the actual number of communions made at Easter rose from 134,000 in 1905-6 to 144,000 in 1908-9, and that the total number of persons upon all the Welsh communicant rolls was, in the latter year, 193,000. These returns were based upon lists for each parish, with the name and address of each communicant. The Nonconformist lists of "full members" gave the Congregationalists 175,000, the Calvinistic Methodists 170,000, the Baptists 143,000, the Wesleyans 40,000 and the smaller Protestant denominations 19,000 among them. Other figures prepared on behalf of the Church showed that in every diocese in Wales there had for many years past been a constant and substantial increase in infant baptisms, confirmations, and Sunday-school scholars, and that in most cases the numbers had grown in a larger proportion than the population, the inference being that the Church was expanding by conversions from Nonconformity. The Commission found that the Church in Wales provided 1,546 churches and mission rooms, with seating accommodation for 458,917. The officiating clergy numbered 1,597—968 incumbents, 561 curates and 68 others. The seating accommodation provided by the Church in Wales was 22.8% of the population. The accommodation in the Nonconformists' places of worship provided for more than double the total of Nonconformist adherents; the chapel-building debt of the Calvinistic Methodists amounted in 1906 to £668,000, and of the Congregationalists to £318,000. On the other hand the Anglican Church accommodation failed to keep pace with the increase of the population. Resident clergy, however, grew by 111% and regular Sunday services by 176%. Much controversy arose as to the accuracy of the figures presented on the one side or the other, but in the end it appeared to be clear that the Church of England was numerically the largest single religious body in Wales. The Commission found the total gross endowments of benefices in Wales in 1906 to be £242,669. (A Parliamentary return issued in Nov. 1912 showed it to be then £260,937.) Of this sum £135,980 is income of endowments believed to have been in existence in 1703; £37,344 is income derived from Queen Anne's Bounty; £49,669 is income derived from the Ecclesiastical Commissioners; £19,672 comes from private gifts since 1703.

*Welsh Disestablishment.*—Before the Commission could report the Government in 1909 brought in a bill for the disestablishment and disendowment of the Church in the four Welsh dioceses and the county of Monmouth, generally similar in its provisions to the bill of 1805, but withdrew it after the first reading. The date after which private benefactions were to be exempt from the operation of the Measure was fixed at 1662, instead of 1703, as in the former bills. In April 1912 a fresh disestablishment and disendowment bill was introduced which admittedly took away 13s. 4d. in the £ of the endowments. The measure, after numerous alterations and amendments, and after being twice

rejected by the House of Lords, received the Royal Assent under the Parliament Act, in Sept. 1914. Coincidentally with it a Suspensory Act was passed, postponing its operation as regards disestablishment, but not disendowment, for 12 months, or until the conclusion of the World War, whichever should be the longer period; by a subsequent Order in Council the date of disestablishment was postponed until the end of the war. Under the Established Church (Wales) Act, the vested interests of incumbents were preserved for their lives. Welsh Church Commissioners were appointed to whom were transferred all property belonging to the Church in Wales which was vested in the Ecclesiastical Commissioners and Queen Anne's Bounty; the property left to the Church was transferred to a Representative Body, appointed by the Welsh Church. The property so allocated included the churches and parsonages, a proportion of the value of the glebes, private benefactions since 1662, and all the movables contained in the churches. The tithes, rent charges and other property of which the Church was deprived went to the Welsh County Councils and the university of Wales. The Act was modified by the Welsh Church (Temporalities) Act passed in 1919. Under this measure a sum of £1,000,000 was granted by Parliament to the Church in Wales, mainly as compensation for the increased value of tithes since the passing of the principal Act, and the date of disestablishment was finally fixed as March 31 1920. The Parliamentary history of this legislation is dealt with elsewhere.

*Constitution of the Church in Wales.*—The constitution of the disestablished Church was drafted by a Convention consisting of representatives of each of the four Welsh dioceses. The Convention decided that the Church should be called "The Church in Wales," and that the governing body shall consist of the diocesan bishops and their suffragans or assistant bishops, the dean and archdeacons, 25 elected clergy and 25 elected laity from each diocese, together with 12 co-opted women. The governing body is to maintain the Articles, doctrines, rites and formularies of the Book of Common Prayer, subject to subsequent modification. New canons may be made by a two-thirds majority of the diocesan bishops, clergy and laity. The Representative Body consists of the diocesan bishops, four clergymen and eight laymen from each diocese, 12 co-opted members and eight nominated by the bishops; subject to the assent of the governing body, 12 women may be added. The Representative Body will act as trustees of the Church's property, under the orders of the governing body. The bishops are to be elected by a board of 33 electors, consisting of the remaining bishops, six clerical and six lay representatives of the vacant diocese, and three clerical and three lay representatives of the other dioceses. The election must be by a two-thirds majority, failing which the appointment is to be made by the Archbishop of Canterbury. Presentations to livings are to be made by Diocesan Patronage Boards, but every third appointment is reserved to the bishop. Benefices are held for life, subject to the right of the governing body to divide or rearrange parishes, to the right of the bishop, with the consent of the patronage board, to remove an incumbent to another living of equal or greater value, and to the right of the Supreme Tribunal to deprive an incumbent whose conduct "grievously hinders" the welfare of the Church. In case of such removal reasonable provision is to be made for the maintenance of the priest so removed. On April 1 1920, a week after disestablishment became effective, a Province of Wales was constituted and the Bishop of St. Asaph (Dr. Edwards), was elected Archbishop of Wales; but it was anticipated that ultimately the Primacy would be attached to the See of St. David's. The new archbishop was enthroned by the Archbishop of Canterbury in St. Asaph cathedral on June 1 1920. It is intended, so soon as circumstances permit, to divide the dioceses of St. David's and Llandaff. A fund of £1,000,000 was started for reindowment; rather more than half the required amount had been obtained by June 1921.

*The Kikuyu Conference.*—In 1913 an event occurred which for a time threatened serious consequences to the unity of the Church and caused much excited and angry feeling. In June

of that year 60 missionaries, representing the different missionary societies working in British East Africa, met at the Church of Scotland station at Kikuyu, on the Uganda railway, to discuss the possibility of a federation between the Christian bodies working in that region. Among those present were the Bishop of Uganda, who presided, and the Bishop of Mombasa; representatives of the Church of Scotland; the (American) Africa Inland Mission; the Friends' Industrial Mission; the United Methodists; the Lutheran Mission, and the Seventh-Day Adventists. The Conference adopted a "constitution," the preamble of which declared that "with a view to ultimate union of the native Churches, a federation of missionary societies should be formed." The "constitution" settled the following basis of federation: "The loyal acceptance of the Holy Scriptures as our supreme rule of faith and practice; of the Apostles' and Nicene Creeds as a general expression of fundamental Christian belief, and in particular belief in the absolute authority of Holy Scripture as the Word of God, in the Deity of Jesus Christ, and in the atoning death of our Lord as the ground of our forgiveness; recognition of common membership between the Churches in the federation; regular administration of the two Sacraments, Baptism and the Lord's Supper, by outward signs; a common form of Church organization." At the end of the conference there was a corporate Communion celebrated by the Bishop of Mombasa, in which the whole of the delegates participated. The inevitable storm speedily broke. In Nov. the Bishop of Zanzibar published an open letter to the Bishop of St. Albans entitled "*Ecclesia Anglicana: what does she stand for?*" in which, declaring that "there has not been a conference of such importance to the life of the *Ecclesia Anglicana* since the Reformation," he charged the Bishops of Mombasa and Uganda with heresy, and asked for the judgment of his fellow bishops of the Province of Canterbury upon what had happened. The Bishop of Uganda immediately replied, defending his action and explaining that the corporate Communion was an exceptional incident standing apart from any general scheme of federation. After further controversy the Archbishop of Canterbury, having refused to take proceedings for heresy and schism against the incriminated bishops, referred the subject to the Central Consultative Body of the Lambeth Conference, which consisted of 14 bishops representing various parts of the Anglican Communion. The following is a summary of the decisions (April 1915) of this body, which actually consisted of the Archbishops of York, Armagh, the West Indies, Rupert's Land, and the Primus of Scotland, the Bishops of Winchester, Exeter and Gibraltar, Bishops Copleston, Wallis, and Ryle:—

"Ministers recognized in their own bodies may be welcomed as visitors to preach in Anglican churches provided they are accredited by the Diocesan Bishop. 2. Non-Anglicans may be admitted to the Holy Communion at the discretion of the Diocesan Bishops, on condition of the acceptance of the Apostles' and Nicene Creeds, the absolute authority of Scripture as the Word of God, and the Deity of our Lord. 3. Anglicans must not receive the Holy Communion from ministers not episcopally ordained or whose orders are otherwise irregular."

With reference to the corporate Communion, the Consultative Body, while recognizing that it was an abnormal and spontaneous act of devotion, added that "any attempt to treat it as a precedent, or to encourage habitual action of the kind, must be held to be inconsistent with principles accepted by the Church of England. . . . So far from promoting unity it would, in our judgment, rather imperil the measure of unity which we now possess." Meanwhile the Bishop of Zanzibar had renounced communion with the Bishop of Hereford (Dr. Percival) on the ground that he had given a Canonry in his cathedral to the Rev. B. H. Streeter, who was accused of "Modernist" teaching. Prolonged controversy followed both of these events, in the course of which in 1917 the bishops of the Province of South Africa, assembled in Synod, criticised the Kikuyu scheme on the grounds that it dealt exclusively with natives and ignored the essential difficulties between the various denominations, and that more could be done "by holding fast to Catholic

order" than "by laxity and compromise." In July 1918 another conference was held at Kikuyu at which an "alliance of missionary societies in British East Africa" was concluded, after an alternative scheme for a united Church, as distinguished from an alliance, proposed by the Bishop of Zanzibar, had been rejected. The alliance consists of the Church Missionary Society, the British and Foreign Bible Society, the Church of Scotland Mission, the United Methodists, and the Africa Inland Mission. The societies forming the alliance pledge themselves to respect one another's spheres, and the autonomy of each member of the alliance within its own sphere; to foster the desire for union; to develop local Church organizations along similar lines of councils, parochial and district; to recognize the status of each other's Church members; to discourage proselytizing; and to respect the disciplinary decisions of the allied societies regarding their own members.

*Increase of the Episcopate.*—The movement for the division of unwieldy dioceses has resulted since 1914 in the erection of five new sees. In that year there were created: Sheffield (taken from York); Chelmsford (taken from St. Albans); and St. Edmundsbury and Ipswich (taken from Norwich and Ely). In 1918 the diocese of Coventry was formed (taken from Birmingham and Worcester); and in 1920 that of Bradford (taken from Ripon and Wakefield). A committee appointed by the Archbishop of Canterbury prepared a comprehensive scheme for the division of large dioceses in the Southern Province, and several proposals to this end took more or less practical shape. A committee was considering in 1921 the best means of dividing London into two or three bishoprics, and a similar project was being prepared for Winchester, which presents peculiar difficulties owing to the complexities of a convenient division and the impossibility of a bishop with a reduced income living at Farnham Castle. In Manchester a diocese of Preston was to be carved out of the mother see. It was proposed to divide the diocese of Oxford into three portions, roughly coextensive with the three counties—Oxford, Berkshire, and Buckinghamshire—of which it mainly consists; with new see towns at Reading for Berkshire and Aylesbury for Buckinghamshire, but the scheme made only slow progress. It was hoped to form a Shropshire diocese by the division of Lichfield, to relieve Southwell by taking from it the county of Derby, and to form a diocese of Plymouth from that of Exeter. Meanwhile the necessity for increased episcopal supervision was being inadequately met by the erection of new suffragan bishoprics. There were in 1921 42 dioceses in England and Wales.

*The Supply of Clergy.*—The scarcity of clergy, which had been growing annually more acute, was accentuated by the war. But the possibilities of obtaining candidates from the services after the end of the war seemed to be so favourable that in 1917 a Service Candidates' Committee was formed for the training of ordinands who had served in the forces. By the time it got into working order the Church was short of 2,000 clergy. The disused prison at Knutsford in Cheshire was taken over as a school for the testing of vocations and intellectual fitness, and by the end of 1920 more than 1,500 men were at work and nearly 250 others had been ordained. The supply of ex-service men being exhausted, civilian candidates are now (1921) being tested there. There has been a necessary postponement of the intention of the bishops to enforce a higher standard of education by requiring candidates for Holy Orders to possess a recognized degree and to have undergone at least one year's training at a theological college. Meanwhile an agitation began in 1914 in favour of the admission of women to the priesthood, and in 1916 the Central Council of the National Mission of Repentance and Hope gave a general approval to the "women's movement." In 1917 Miss Maude Royden, one of the leaders of the movement, began a ministry of preaching, first at the City Temple and subsequently in a hall taken for the purpose; in 1921, after preaching the three Hours' addresses on Good Friday at St. Botolph's, Bishopsgate, she acquired a chapel of her own. In a large number of dioceses women messengers and pilgrims are at work under the guidance of the parochial clergy.

*The Church and the State.*—At the beginning of 1918 there was a lively controversy upon the appointment of Dr. H. Henstley Henson, Dean of Durham, to the bishopric of Hereford, and a public meeting of churchmen in London asked that the Crown should appoint "a small Commission of Churchmen to assist in the exercise of its ecclesiastical patronage." In 1920 Canterbury Convocation resolved that the two archbishops ought to be consulted by the Prime Minister before he submitted names for appointment to bishoprics. The Prime Minister replied that it had been his "invariable practice" to do so. In consequence of the rapid increase in the value of tithe rent charge by reason of the high prices of agricultural produce, an Act was passed in 1918 fixing the value at £109 3s. 11d. until 1926. The increase in local rates caused a determined agitation against the rating of tithe rent charge, on the ground that it is professional income, and that no other earned income is rated, which led in 1920 to the passing of the Ecclesiastical Tithe Rent Charge (Rates) Act. Under this measure the rates are restricted, during the

currency of the Tithe Act of 1918, to the amount payable in that year, with the proviso that where a benefice does not exceed £300 in value no rates will be payable on the tithe, and that if it exceeds £300 and does not exceed £500 one-half the rate only will be payable. Since the Act of 1918 sales of ecclesiastical tithe rent charge have greatly increased; it may be added that, in consequence of the improved value of agricultural land, there have been very extensive sales of glebes, to the substantial enhancement of the value of many benefices. A movement has been set on foot for relieving clergy of the Church of England from the statutory disability of sitting in the House of Commons and on municipal corporations. A bill with this object passed its second reading in the Lords in 1919 but in Committee the relief as regards Parliament was struck out. It was reintroduced in the Commons in 1920, but made no progress. In 1919 a Union of Benefices Act, limited in its duration to Dec. 31 1921, enabling the Ecclesiastical Commissioners, with the concurrence of the bishop of the diocese, to prepare after public enquiry schemes for the amalgamation of small contiguous parishes, was passed. These unions became effective by Order in Council.

*Doctrine, Discipline and Ritual.*—During the decade several important events affecting the doctrine and discipline of the Church of England occurred. The first turned upon the interpretation of the Deceased Wife's Sister Marriage Act of 1907, and led to the suit of *Banister v. Thompson*. The plaintiff married his sister-in-law in Canada, where he had no domicile, under the Colonial Act, before the passing of the English Act, and was refused communion by his vicar, the defendant. The Court of Arches found in 1908 that the passing of the Act of 1907 validated the marriage as a civil contract, and that therefore the parties could not be repelled as "notorious evil livers," to use the language of the rubric which the defendant held to justify his refusal. The High Court, by a majority, upheld this decision, which was endorsed by the Court of Appeal and confirmed by the House of Lords in June 1912. In 1911 the Rev. J. M. Thompson, Fellow and Tutor of Magdalen College, Oxford, published *Miracles in the New Testament*, which produced an animated controversy. In the result the Bishop of Winchester, as visitor of the college, withdrew the licence he had granted to Mr. Thompson who was, and continued to be, dean of divinity, on the ground that the book denied the articles of the Creed affirming the Incarnation and the Resurrection. There has been much discussion upon the propriety of permitting Reservation of the Eucharist, and in 1917 the Upper House of Canterbury Convocation reaffirmed the draft rubric on the subject which it is proposed to insert in the revised Prayer Book. This rubric permits Reservation for the sick, and provides that if the consecrated elements are not taken immediately to the sick person "they shall be kept in such place and after such manner as the Ordinary shall approve, so that they be not used for any other purpose whatsoever," the object being to prevent the spread of organized devotions before, or in the presence of, the Sacrament. In 1919 and 1920 an acute controversy arose upon the adoption of the service of Benediction in a few churches, and two clergymen were deprived of their livings for persistence in celebrating the rite—the Rev. L. S. Wason, perpetual curate of Cury-with-Guawalloe, in Cornwall, and the Rev. R. Wynter, vicar of St. John Taunton. Mr. Wynter, together with a number of his parishioners, was shortly afterwards received into the Church of Rome. In 1918, the Bishop of Manchester (Dr. Knox) refused to institute the Rev. C. S. Carey to the living of Sacred Trinity, Salford, on the ground that he was habitually guilty of reserving the Sacrament, wearing Eucharistic vestments, using incense ceremonially, and lighting candles when not required for giving light. The case went to the High Court, and Mr. Justice Coleridge gave judgment in favour of the bishop, on the ground that three of the four practices are illegal. An appeal was not pressed, the patron having agreed to accept another presentee.

*Care of Church Buildings.*—Doubts having been expressed as to the efficiency of the supervision by the Church of the ancient monuments under her care, a committee was appointed in 1912, under the auspices of the Dean of the Arches, which reported favourably upon the extent of the supervision exercised, but expressed the opinion that more attention might sometimes be given to aesthetic considerations. Recommendations in the direction of better supervision of works of restoration were made, and a number of diocesan advisory committees were appointed. In 1913 an Ancient Monuments Act was passed which created boards for England, Scotland, and Wales to advise the Commissioners of Works upon the repair of monuments, and in 1920 a committee was appointed to consider the advisability of strengthening the Act and including in its scope churches and other ecclesiastical buildings still in use. Shortly afterwards the House of Lords passed a motion condemning the Government for appointing the committee "without consultation with the Church authorities and without some proof that the provisions for the protection of cathedrals and churches which have prevailed for centuries have proved inadequate." Shortly before a commission appointed by the Bishop of London had recommended that 19 of the City churches should be removed, as being redundant. A great outcry followed, and in the end the Bishop of London undertook not to settle the matter finally without the concurrence of the National Assembly. The subject was kept prominently before the public by the necessity, revealed at the end of the war, for exten-

sive and costly repairs to several of the most famous ecclesiastical monuments in England, notably Westminster Abbey, which will require approximately £250,000 for its repair, and St. George's Chapel, Windsor, the choir of which was found to be dangerously unsafe. St. Paul's cathedral has also given great anxiety. The pressure of the dome upon the piers caused them to give signs of instability, and for several years the work of strengthening them has been proceeding slowly and at great cost.

*Canada.*—During 1910-21 there was great activity in the Church of Canada in consequence of the enormous influx of English settlers, especially into the N.W. provinces. The first service of the English Church in what is now the dominion was held at Annapolis Royal in 1710, and the bicentenary was marked by the opening of a new cathedral at Halifax, Nova Scotia. To meet the needs of a rapidly growing population unable to provide for its own spiritual needs the Archbishops' Western Canada Fund was established in 1910 for the provision of men and money to meet these needs, and the Rev. W. G. Boyd, one of the chaplains of the Archbishop of Canterbury, went out at once with five clergy and four laymen, who worked on the Bush Brotherhood system, and were afterwards joined by many others. By the time the fund, which was always intended to be of limited duration, came to an end in 1920, it had built 68 churches in connexion with the Edmonton, Alberta, and Railway Missions. In 1912 a mission of help was sent to the Province of Rupert's Land. In 1911 British Columbia was erected into a province and in 1912 it was decided that instead of one province for the whole of Canada E. of Manitoba, a new ecclesiastical province of Ontario should be formed to include the dioceses of Ottawa, Algoma, Huron, Niagara, Ontario and Toronto. There are consequently now four Canadian provinces. In 1913 the archdeaconry of Edmonton was constituted a diocese, and in the same year it was decided to form a diocese of Brandon out of that of Rupert's Land; this see has not yet come into actual existence. It is also proposed to create a see of Saskatoon by dividing the diocese of Saskatchewan. A new Canadian Prayer Book was adopted in 1918.

*Australia and New Zealand.*—In Australia the "Question of the Nexus" which arose in 1912 is still pending. Distinguished counsel have stated their opinion that the Church in Australia is an integral part of the Church of, and in, England, and that it is bound by the judgments of the Judicial Committee of the Privy Council. There is a movement in the direction of independence, but considerable opposition has been manifested to any disturbance of the *status quo*. A more local yet important disturbance of harmony was caused by a question of vestments at Sydney in 1910. The only churches in that city in which vestments were used were St. James's and Christ Church, and the incumbencies of both fell vacant within a few months of each other. The Archbishop of Sydney refused to institute any clergyman who declined to give an undertaking not to use, or allow to be used, "the chasuble or other vestment in any church under his charge until, in the judgment of the Archbishop of Sydney for the time being, they have become legal." In each case this requirement caused a long delay in making an appointment, and the incident produced a serious division of opinion in the diocese. The first portion of Brisbane cathedral was consecrated in 1910. In 1914 the creation of a diocese of Kalgoorlie enabled the erection of Western Australia into a province, the Bishop of Perth becoming archbishop and metropolitan. Two other new dioceses have been formed in Australia—Willochra and Grafton—both in 1914, the latter taken from the old see of Grafton and Armidale. A mission of help was sent from England to New Zealand in 1911.

*India.*—The centenary of the Indian Episcopate was celebrated in 1914. Thomas Fanshawe Middleton having been consecrated on May 14 1814 first Bishop of Calcutta, a see which originally included also Australia, New Zealand, Mauritius, and Cape Colony. In 1915 a bishopric of Assam, cut away from the Metropolitan Diocese of Calcutta, was formed, and in 1912 a native priest was, for the first time, raised to the Episcopate, the Rev. V. S. Azariah being appointed Bishop of the new see of Dornakal, in Hyderabad State. In 1913 the bishops decided that the time had come for the introduction into India of full synodical government; but legal opinion was opposed to the practicability of the change, and it was consequently decided that a provincial council, consisting of bishops, clergy, and laity should be formed on a voluntary basis, side by side with the Episcopal Synod. Diocesan councils are also to be erected, and a beginning has been made in that direction. In consequence of the intended removal of the capital to Delhi, the Provincial Synod of Calcutta has prepared a memorandum suggesting the formation of two new archbishoprics—one of Madras to include the sees of Madras, Tinnevely, Travancore, Colombo and Dornakal; and another of Delhi, to include Delhi, Lahore, Lucknow, Bombay and Nagpur. Much attention has been given to the position of the Eurasians, whose education has been greatly neglected in the past. Roman Catholic and Nonconformist schools have provided for large numbers of what is now called the domiciled English community, and special funds are being raised for improving and strengthening the Anglican schools in the great centres of population.

*Africa.*—Two new dioceses have been formed in South Africa—George, taken out of the sees of Cape Town and Grahamstown (1911), and Kimberley and Kuruman, taken out of the diocese of Bloemfontein (1912). In 1913 the diocese of Mashonaland was renamed

**Southern Rhodesia.** The missionary diocese of Western Equatorial Africa (originally the Niger) was divided in 1919, the diocese of Lagos being carved out of it. Khartum cathedral was consecrated in 1912. A missionary diocese of Egypt and the Sudan was created in 1920; the cathedral, to be erected at Cairo, is intended to be a memorial of Lord Kitchener, Lord Cromer, and the men of the Imperial forces who fell in Gallipoli and Egypt during the World War.

**China and Japan.**—In 1909 a new diocese of Kwangsi and Hunan was formed out of the diocese of Victoria; the new diocese of Honan has also been formed and allocated to the Canadian Church. Archbishop F. S. Sing, the first Chinese to be raised to the Episcopate, was in 1918 consecrated Assistant Bishop for the diocese of Chekiang. In 1909 the Missionary Church in China took the name of "The Holy Catholic Church of China," and in 1913 constitutions and canons and a general synod were formed. In 1912 a theological college for training native candidates was established. The American Church has been asked to work the new diocese of N.E. Japan, to be formed by the division of the diocese of N. Tokyo.

**Miscellaneous Events.**—In 1916 an elaborately organized National Mission of Repentance and Hope took place, the object of which was compendiously stated to be the inducement of "a serious determination on the part of the nation to seek and deserve divine help." It was otherwise described as "a mission of witness by the Church as a whole to the nation as a whole." After various stages of preparation, the "Message to the Nation" was delivered during a few days in each parish by a large body of "Bishops' messengers," consisting of clergy and laity, some of the latter being women. Subsequent stages continued in 1917, and many committees were appointed to consider outstanding subjects arising out of the mission, such as public worship, evangelistic work, problems of industrial life, the reaching office of the Church, etc. The reports of these committees, although some of them have provoked much criticism, have been generally regarded as of greater practical importance than the immediate results of the mission itself. In 1917 a similar mission was held in Scotland. These events were followed by an "Anglo-Catholic Congress" in 1920, the purpose and aim of which were officially defined as "to extend the knowledge of Catholic faith and practice at home and abroad, and by this means to bring men and women to a true realization of our Lord Jesus Christ as their personal Saviour and King." Fourteen thousand members took part, and the subjects discussed (with many sub-headings to each) were "The Message of the Church," "Our Position," "Christian Unity," "Corporate Religion," "Personal Religion," and "The Church and Social and Industrial Problems." Before the year was out £36,000 had been raised towards a thankoffering of £50,000 for foreign missions. The work of the Congress was continued by a "Conference of Catholic Priests" at Oxford in July 1921. The Church Congress kept its jubilee in 1920 at Cambridge, its birthplace; in 1914 it was for the first time intrimitted on account of the war, and not resumed until 1919, when it met at Leicester.

**BIBLIOGRAPHY.**—Many books of importance in theology and Biblical criticism, or as reflecting the development of opinion and the results of scholarship, were published between 1910 and 1921. Among them may be mentioned the following: *Foundations: A Statement of Christian Belief in Terms of Modern Thought* (1912), by Seven Oxford Men; B. H. Streeter, *Restatement and Reunion* (1914); W. Sanday, *The Primitive Church and Reunion* (1913); F. W. Puller, *The Continuity of the Church of England* (1913); A. Nairne, *The Epistle of Priesthood* (1913); S. Baring Gould, *The Church Revival* (1914) and *The Evangelical Revival* (1920); J. N. Figgis, *Churches in the Modern State* (1913); Edouard Naville, *The Archaeology of Jesus in the Testament* (1913); H. Latimer Jackson, *The Eschatology of Jesus* (1913) and *The Problem of the Fourth Gospel* (1918); James Gardiner, *Lollardy and the Reformation* (1908-13); J. R. Illingworth, *The Gospel Miracles* (1915); A. C. Headlam, *The Miracles of the New Testament* (1914); F. E. Brightman, *The English Rite* (1915); T. A. Lacey, *Unity and Schism* (1917); J. K. Mozley, *The Christian Hope in the Apocalypse* (1915); H. B. Swete, *The Holy Catholic Church* (1915); G. H. Box, *The Virgin Birth of Jesus* (1916); *Correspondence of John Henry Newman with John Keble and others 1839-1845*; William Temple, *Mens Creatrix* (1917); H. M. Gwatkin, *Church and State in England to the Death of Queen Anne* (1917); J. N. Figgis, *The Will to Freedom* (1917); J. P. Whitney, *The Episcopate and the Reformation* (1917); M. G. Glazebrook, *The Faith of a Modern Churchman* (1918); *Essays on the Early History of the Church and the Ministry* (1918), ed. H. B. Swete; Charles Gore, *Dominant Ideas and Corrective Principles* (1918); J. H. Shakespeare, *The Churches at the Cross Roads* (1918); H. Rashdall, *The Idea of Atonement in Christian Theology* (1919); W. R. Inge, *Unspoken Essays* (1920); Oscar D. Watkins, *A History of Penance* (1920); A. C. Headlam, *The Doctrine of the Church and Christian Reunion* (1920); Kirsopp Lake, *Landmarks in the History of Early Christianity* (1920); R. H. Charles, *The Apocalypse* (1921). (J. P.-B.)

## II. ROMAN CATHOLIC CHURCH

The decade 1910-20, including the last four years of the pontificate of Pius X. and the first six years of that of Benedict XV., proved an eventful period for the Catholic Church,

*The Church and the Civil Power.*—Several interesting questions in the relations of the Church to the civil power were put to the test of practical working.

In France the friction between the Vatican and the French Republic had resulted in 1905 in the separation of Church and State and the rupture of diplomatic relations. It had followed upon the refusal of Pius X. to permit the effective intervention of the French Government in the trial and removal of two French bishops in a matter of purely ecclesiastical discipline. The bill of separation enabled the State to take possession of Church property and to withdraw the subsidy for the clergy. It placed the upkeep of the Church in the hands of voluntary parochial corporations (*associations cultuelles*) which to a large extent would have been subject to the control and supervision of the civil authority. Pius X. declared the refusal of the Church to accept such conditions, and the French bishops, as a body, although menaced with the loss of their incomes, their dwellings, seminaries, and funds vested for religious and charitable purposes, supported the Pope in his refusal. A compromise, which would have turned the *associations cultuelles* into *associations canonico-légales*, was proposed and would, it is said, have found favour with a large number of the bishops, as apparently safeguarding sufficiently the liberty of the Church, but when the Holy See affirmed the safeguards to be inadequate, and declined to sanction it, the French episcopate unanimously accepted its decision, and affirmed its readiness to face any sacrifice rather than that of Church freedom and unity.

During the fifteen years before 1920 the Church in France had to maintain itself upon the voluntary offerings of the faithful, and the result of the experiment may be said to be that, despite manifold losses and difficulties, it has entered upon a new era of vigour and freedom. The State no longer presents to the bishops, and the Holy See is free to select and appoint bishops of its own choice in consultation with the bishops of the province. In fact, just as the Concordats with Francis I. in 1516 and Napoleon I. in 1801 practically superseded or abolished capitular election, and substituted nomination or presentation by the head of the State, leaving institution or effective appointment to the Pope, so now the abolition of the Concordat has led to the adoption of what may be called the List system, which promises to be the method of the future, not only in France but in all countries in which there is no longer the union of Church and State. By this arrangement, a list of priests who by their qualifications are reputed to be eligible for promotion to bishoprics is kept at Rome, and is drawn up in consultation with the local episcopate. When sees become vacant the Holy See fills them from the persons so nominated, on the advice of the Consistorial Congregation. The procedure to some extent marks a new era in the history of methods of episcopal appointment. Thus on Feb. 25 1905 Pius X. himself consecrated in St. Peter's at Rome no less than 14 bishops thus chosen for vacant French bishoprics. At the same time the abolition of the Concordat has freed the hands of the bishops from many civil formalities or restraints in the government and organization of their dioceses. A notable example of this liberty and progress has been seen in Paris, where the late Cardinal Amette, before his death in 1920, was able to found some 32 new parish churches in the environs of the city. Clerical authorities, notably the well-informed *Annuaire Pontifical Catholique* of 1915, describe the Church of France, 10 years after its separation from the State, as gaining in energy, influence and freedom. Although the State shows no disposition to depart in any respect from the policy of separation, its attitude to the Church, especially from the outset of the World War, has been in many ways more friendly, based on the higher policy of the *Union Sacree*, and in 1920 the French Government passed a bill for the renewal of diplomatic relations with the Pope and restored the French embassy at the Holy See, while a papal nuncio was once more to be sent to Paris.

A much more violent case of separation of Church and State was that which was effected by the revolution in Portugal



in 1910. The revolutionary government which had deposed Dom Manuel promptly abolished the Concordat of 1778, based on the Concordat concluded between Pope Leo X. and King Emmanuel in 1516, seized the temporalities of the Church and placed them under the control of lay corporations resembling the French *associations cultuelles*. As any word, written or spoken in public, blaming or criticising the action of the Government, was forbidden under the severest penalties, in a short time the Patriarch of Lisbon, Mgr. Mendes de Bello, and several of the bishops were exiled, and a large number of the clergy imprisoned or deported. The Holy See, in the Encyclical *Jandudum* (May 24 1911), refused to recognize the lay corporations, forbade the clergy to accept the pensions offered by the Government, and exhorted the bishops to stand firm while waiting for better times.

The ten years preceding 1921 brought into play the wisdom of milder measures. More moderate rulers succeeded the earlier extremists, and the legislation in Portugal on ecclesiastical matters was mitigated, so that the bishops and clergy were able to return to their sees and parishes, and an arrangement acceptable both to Rome and the Government was gradually worked out, so that in 1918 diplomatic relations were resumed with the Holy See. In fact, Cardinal Gasparri, the papal Secretary of State, at a dinner given in 1920 to the Portuguese envoy, publicly expressed his congratulations on the good understanding prevailing between Portugal and the Holy See.

It would be difficult to forecast with accuracy from such events how far the traditional union of Church and State based on Concordats will be, in the future, compatible with the principles and programme of liberal or revolutionary governments amongst the Latin nations. That the actual separation of Church and State demanded by such governments need not necessarily mean a rupture between the two powers, and may be carried out in a friendly spirit in which the right and liberty of both are respected, would seem to be indicated by the modifications which have followed upon the revolution in Brazil since 1890. In that country the Church, after the separation, has been left fairly free in the control of her property, with powers as a corporation to possess and receive bequests. In 1905 Pius X. had marked his satisfaction with the action of the Brazilian Republic by raising the Archbishop of Rio de Janeiro, Mgr. Arcoverde de Albuquerque, to the Sacred College and giving to Brazil the honour of having the first cardinal ever created in South America. The papal nuncio presided over the diplomatic commission which sat for some five years and succeeded in maintaining peace and arranging all the points of dispute between the three republics, Brazil, Peru and the Argentine. In 1918 the Senate of Brazil, by a unanimous vote, appointed a commission to congratulate Pope Benedict XV. on the anniversary of his coronation, and to thank him for his efforts for peace during the World War. Since then, chaplains and religious services have been restored in the Brazilian navy, and notable Church progress has been made in the vast territories of the republic by the erection of new sees and the organization of missions in the Chaco and far interior.

In Serbia the great majority of the population belongs to the Eastern Orthodox Church, and before the war the number of Catholics in the kingdom was estimated at 8,000. Over these the Emperor of Austria, by the treaty of Carlovitz, exercised a protectorate which gave him a handle for intervention in Serbian affairs, and became a factor of considerable political value. The Serbian Catholics were placed under the jurisdiction of the Albanian Archbishop of Scutari, and Austria was credited with the design of making use of this protectorate to promote her ambitions of eastward extension, which had the port of Scutari for its objective. To the great displeasure and annoyance of the Emperor of Austria and his Government, the Holy See in June 1914 practically crushed this scheme by abolishing the protectorate and by concluding a Concordat with Serbia which, by the inclusion of Uskub, had now a Catholic population of some 76,000 Catholics. By this Concordat the full and free exercise of their religion was guaranteed to the Serbian Catholics,

and an ecclesiastical province, consisting of the archbishopric of Belgrade and the bishopric of Uskub, was recognized and endowed by the Government. The Catholic Church as a legal corporation was to have complete liberty to possess and to administer her temporalities. Teachers of the Catholic catechism (who might be priests) were to have free entry into the State schools, and as long as they enjoyed the approbation of the Catholic bishops were to be paid by the Government for their services. This Concordat was ratified by Pope Benedict XV. in March 1915, and diplomatic representation has been established between Serbia and the Holy See.

A still more important step in the appreciation of the political advantages of representation at the Vatican as a centre of influence and information was taken by the British Government in 1914 by sending as its envoy to Rome the late Sir Henry Howard, who in 1916 was succeeded by the Count de Salis. In 1915 Holland followed the example of Great Britain and appointed a temporary representative, and in 1917 Luxemburg resumed the diplomatic relations which had been suspended under Leo XIII. In the same year the new Russian Government which came into power after the fall of the Tsar sent a minister plenipotentiary as its representative to the Holy See, and the Pope was able to procure the liberation of the Ruthenian Bishop of Lemberg, who had been sent into exile. On learning of the arrest of the Tsar and Tsaritsa and their family, Benedict XV. made earnest efforts with the Maximalist Russian Government, but without success, to procure their liberation. In 1919 Archbishop Sylvester of the Russian Orthodox Church wrote to the Pope describing the cruel persecution to which he and his co-religionists were subjected, and Benedict XV. wrote to Lenin begging him to act fairly to members of all religions, but received from the Foreign Minister, Tchicherin, an evasive reply. At the same time the Letts petitioned the Pope to erect Danzig into an archbishopric, and in August 1919 the Government of the Ukraine sent an envoy to represent its interests at the Holy See.

The diplomatic activity of the Vatican during this period made itself felt in various directions. In 1917 Benedict XV. addressed a strong remonstrance to the German Government against the deportation of French and Belgian workmen, and received through Count Hertling, the Foreign Minister, an assurance that deportations would cease, and that those who were deported in error would be sent back to their homes. He obtained later on from that Power that prisoners-of-war suffering from consumption or similar diseases should be allowed to go to hospitals or homes in Switzerland or neutral territory. Large numbers of the prisoners thus transferred addressed to the Holy See a letter of thanks for this intervention in their favour.

In 1918 a new treaty was concluded with Spain, which went to obviate the danger of over-multiplication of monasteries. In the same year in Canada there arose a vehement agitation amongst the French-speaking Catholics against the new bilingual school laws in Ontario. The Pope dispatched to Cardinal Bégin, Archbishop of Quebec, an apostolic brief strongly exhorting all concerned to mutual peace and good-will, and giving directions as to the steps to be taken to effect a conciliation of the various parties. In the same year the Vatican received a solemn embassy and special envoy from the Empress of Abyssinia, with every assurance of her friendship. A diplomatic mission was received at the same time from the new Chinese Republic, and a convention was concluded by the Holy See and the Emperor of Japan, in accordance with which the German missionaries in the Caroline and Marshall Is. were replaced by the Capucin friars, who are under French superiors.

It may also be of interest to those whose studies in Church history lead them to the work of research in the Vatican archives that in July 1918, through the zeal of Cardinal Gasquet, Prefect of the Vatican Library, a friendly agreement took place between the Vatican and the Italian Government by which the latter restored to the Vatican archives a large quantity of valuable documents and Church records which had fallen into its possession at the occupation in 1870, and the Vatican in return handed over to the Government a similar quantity of title-deeds of property and documents concerning the civil administration of the city and province which had been retained in its keeping. This mutual concession and the amicable way in which it was conducted showed a new spirit of conciliation between the Vatican and the Quirinal.

*The Church and the "Exclusivo."*—An event which will be noted by ecclesiastical jurists and students of the relations of Church and State, the abolition of the *Veto* or *Jus Exclusivae*, was solemnly decreed by Pius X. in 1904, and carried out in the Conclave of 1914.

For some centuries past three Catholic powers—Austria, France and Spain—had claimed each to have the right to intervene in the election of a Pope by excluding one cardinal from being elected to the papacy. Save that it barred the succession of someone regarded as personally hostile, the intervention was generally ineffective, as the veto of the civil power was restricted to one cardinal, and this exclusion usually had the result of transferring to some other cardinal of like views and temperament the votes which had been given to the person excluded. Certain writers have supposed that the veto had its origin in the action of the emperors in the Middle Ages who at times confirmed the elections made by the cardinals. Later and fuller research has shown that the practice, at least in its direct form, dates only from the middle of the 17th century. Before that time the sovereigns of the nations mentioned frequently exercised influence upon the cardinals living within their dominions and urged them to form a coalition by which a given candidate, deemed to be obnoxious, might be prevented from having the two-thirds majority required for election. In 1590 the Spanish ambassador even presented a list of candidates who alone would be acceptable to Philip II. So far, the veto was an attempt to sway the electorate, but towards the end of the 17th century it took the direct form of a communication to the Cardinal Protector of the nation concerned, or to the Dean of the Sacred College, expressly excluding a given cardinal, irrespective of the numbers who might be ready to vote for him. The conclave frequently took note of such representations and, as a matter of friendly dealing with the Catholic power from which they emanated, abstained from electing the person excluded, but it is held that the Holy See, while tolerating the practice, has never officially recognized this right of intervention, and has more than once warned the Sacred College to ignore it. In 1721 and in 1732 Cardinal Imperiali was successfully vetoed, first by Austria and then by Spain. In more recent times Austria sent its veto against Cardinal Mastai Ferretti (Pius IX.), but the envoy arrived too late, and the Pope was already elected. In the conclave which was held on the death of Leo XIII. in 1903 Cardinal Rampolla was on the verge of having the required number of votes when Cardinal Puzyna, to the great surprise and displeasure of the assembly, delivered in the name of the Emperor Francis Joseph the veto against his election. This step on the part of the aged emperor is known to have been inspired and carried out by the Foreign Minister, Count Goluchowski, who had been hostile to Cardinal Rampolla when he was nuncio at Vienna. To save the Holy See from diplomatic friction, Cardinal Rampolla, under protest, withdrew his candidature, and his supporters, at his request, transferred their votes to Cardinal Sarto, who as Pius X. succeeded to the papacy. One of the first acts of Pius X. was to issue a solemn constitution (*Commissum Nobis*) in Jan. 1904 abolishing forever the *Veto* or *Jus Exclusivae*, declaring excommunicated by the fact any cardinal who in future would act as bearer of any such communication to the Conclave, and requiring from all cardinals taking part in the election of a pope an oath that they will disregard all such acts of intervention on the part of the civil power. In 1914 Benedict XV. was elected under this constitution, and the historic *Veto* has disappeared as an influence in the elections to the papacy.

*Organic Expansion.*—Next to the regulation of her relations to the civil power, and her diplomatic activities, may be considered the organic work of the Church. Both are intended to clear the field and smooth the way to spiritual efficiency and progress in her diocesan and parochial centres. In this domain may be included the creation of new dioceses and spheres of missionary enterprise. To understand the statistics of the Church's expansion it may be noted that, while a missionary area has still to be evangelized, and is yet in the earliest stage of organization, the Holy See marks out its territory, and places its missionary forces under a prefect-apostolic, who is not a bishop, but has ample powers of jurisdiction. Later on, when it has sufficiently advanced in the number of its churches and Catholic population, it is made into a vicariate under a vicar apostolic, a bishop who has delegated authority from the Pope, and has his episcopal title from some ancient or obsolete see, and is classed as a titular bishop, or what was formerly called a bishop in *partibus infidelium*. Finally, when the work of the Church has become stable and substantial, the vicariate is erected into a diocese, and its bishop, no longer a mere delegate of the pope, becomes an ordinary, invested with full canonical rights and title, and the see takes its place amongst the residential bishoprics of the Catholic Church. With these

three stages in mind, one may fairly measure the Church's organic expansion by the fact that, during 1910–20, there were erected in various parts of the world 29 prefectures apostolic, 41 vicariates apostolic, and 71 new dioceses—altogether 141 territorial units added in the geography of the Church.

As to what are known as the foreign missions of the Church, the field is too vast for exact statistics. The following summary, taken from official sources published in 1918, and stated here in round numbers, may be taken as substantially correct for contemporary purposes.

The number of priests in the mission field is about 12,000, of whom more than 4,000 are natives. They have as helpers about 3,000 lay brothers and about 20,000 nuns. This forms a missionary army of nearly 35,000 workers. To these must be added a body of more than 34,000 catechists and native teachers. The number of the Catholics people in these missions amounts to 17,000,000. Of these, 13,000,000 are in Asia; 1,000,000 in Africa; 13,000 in Australia; 200,000 in Oceania; 230,000 in North American missions, and 1,000,000 in the missions to natives in South America. It is estimated that in the Catholic mission field there have been founded about 1,700 schools, in which are being educated more than 800,000 pupils. These figures represent broadly the missionary work of the Catholic Church.

The work of the foreign missions was seriously affected by the World War of 1914–8. The contributions to their finances from the devastated and from the blockaded countries were naturally diminished, while many of the younger missionaries were recalled to the colours to take part in the contest. No little dislocation of work was caused by the removal of German or Austrian missionaries, as the Holy See, anxious to protect the cause of the missions from being prejudiced by any suspicion of political propaganda, entered into agreements with the Allies by which, in many cases, missionaries who were subjects of the Central Powers were replaced in India and in the conquered German colonies by others who belonged to one or other of the Allied nationalities. Nevertheless, on the whole, most of the missions were numerically stronger after the war.

*Organic Reform.*—Simultaneously with this organic expansion of the Church abroad there took place a notable organic reform at her centre. In June 1908 Pius X. decreed an important reconstruction of the Roman Curia, which may be described as the ruling body of the Holy See. The Roman Curia includes about a dozen departments of Church government, called "Congregations." These are standing commissions charged to deal respectively with matters of doctrine, discipline, worship, episcopal appointments, foreign missions, relations to Oriental churches, and other spheres of ecclesiastical administration. Each is presided over by a cardinal-prefect, who is assisted by a number of other cardinals, and, under them, by a trained council of canonists, theologians and consultants of expert authority. Their decisions, which mostly take the form of answers to questions or petitions addressed to them from various parts of the Catholic world, are issued as decrees, and these, when ratified by the approval of the pope, become part of the authoritative law of the Church. The constitution of Pius X. (*Sapientii Consilio*) maintained the continuity of the congregations and tribunals, but effected changes in their structure and working greater than any which had been attempted since the days of Sixtus V. in 1587. With the constitution were issued 34 canons, which regulate more clearly the distribution of work and go to secure greater efficiency and promptitude in procedure (see 7.639).

Amongst the alterations thus introduced is notably one which deeply interests Catholics in the English-speaking world. After the Reformation, Catholics in England, Ireland, Scotland and in the United States and Canada were classed amongst those of the missionary countries, and were placed under the charge of the Great Congregation of the Propaganda, which controls the missionary work of the Church in all parts of the world, and whose cardinal-prefect is, for that reason, sometimes styled "the Red Pope." Even when the episcopal hierarchy was preserved or restored in these countries, their business at Rome was transacted by the Propaganda, their bishops were appointed by apostolic briefs which it obtained for the purpose, and it was to it that they made the reports of their dioceses when they went to Rome on their periodic visits *ad limina Apostolorum*. By the new constitution all these countries (and with them Holland and Luxemburg) were withdrawn from the care of Propaganda and were transferred to the Consistorial, the congregation which deals with the Church in non-missionary lands, and are to have the same status and ordinary government as the Church in Catholic countries. Although in several of these nations the Catholic population is still in a minority, their bishops will deal with the Holy See through the Consistorial, and be appointed and

preconized in Papal Consistory, and render to it an account of their stewardship, in the same way as the bishops of Italy, France, Austria, Spain or other parts of the world where the bulk of the population is Catholic.

This historic measure is based on the recognition of the progress of the Church in the countries mentioned. It is reckoned that there are now some 12,000,000 of Catholics in the British Empire. There are 17,000,000 in the United States and 5,000,000 in the Philippines, making 22,000,000 under the Stars and Stripes and, in round numbers, about 34,000,000 of the English-speaking world. This total forms more than a ninth part of the whole Catholic Church.

**Restoration of the Rota.**—Another important feature of the same constitution completed by the brief has been the restoration of the well-known Court of the Rota. All who have engaged in the study of mediæval history are familiar with this famous tribunal which was for centuries the supreme court of ecclesiastical appeal for the universal Church. It was this court that in final instance adjudged those cases of appeal to Rome which are found in such numbers in the records of every Catholic country, especially during the Middle and later Middle Ages. Such cases cast a vivid light on the state and working of the mediæval Church, and students of Church history of the school of Maitland, Othenthal or Dr. Sægmüller have found how necessary for a true understanding of them is the knowledge of the methods and procedure of the Rota and the Chancery.

The Rota consisted of a dean and 12 judges, or auditors (usually chosen from the various nationalities), with a large attendant body of advocates and notaries. Each case was heard by a panel or "turbo" of three judges. If a litigant was dissatisfied with the decision he could have the case tried anew, or even a third time by a fresh "turn" of three other judges, one of whom could be chosen by himself, and the other two by the judge thus selected. When two or three of the judgments thus given were concordant, the case was definitely settled. (Hence the clause: "After a third definitive sentence," so often found in the records of appeals in the pre-Reformation centuries.) In the later Middle Ages the volume of judicial business in the Rota was very considerable, but in later times it was notably reduced, as the Holy See had extended and encouraged the system of having cases tried "extra-judicially" by judges delegate, acting by papal authority, but chosen by the litigants themselves, and adjudicating in their own country, as may be seen in numberless entries in the volumes of the *Calendar of Papal Letters* relating to Great Britain.

Pius X. restored the Rota to its ancient preëminence as the chief court of the Catholic Church. It has now a dean, and 10 instead of 12 judges, but its procedure by "turns" or successive sentences on appeal remains substantially unaltered. It is in this tribunal that appeals on matrimonial cases are heard from all parts of the Catholic world, and amongst them such *causæ celebres* as that of Parkhurst and Reid, and Miss Anna Gould and the Marquis Boni de Castellane, who, after strenuous efforts, have failed to obtain a verdict of nullity upon their marriages. A further appeal from the Rota now lies to the commission of judges in the *Apostolica Segnatura*, inasmuch as the latter acts as a court of cassation, and takes cognizance of defects of procedure.

As the Catholic Church condemns the doctrine of divorce, in the sense that any marriage between Christians that has been validly contracted and consummated can be dissolved by anything but the death of one of the parties, the matrimonial cases justiciable in the Rota or the Segnatura are only those in which a plea is brought against validity of the marriage, and is put forward to prove that, for reasons good in Divine or Church law, the bond of matrimony never existed. A modern feature of the restored Rota is that condensed reports of the leading trials are published in the official *Acta Apostolicæ Sedis*, with a summary of the facts (*Compendium Facti*) and of the juridical principles involved (*Compendium Juris*).

**Reconstruction in England and Wales.**—The same policy of reconstruction was applied to the Catholic Church in England. At the restoration of the hierarchy in 1850 the whole of England was included in a single province, having its archiepiscopal see at Westminster. On Oct. 28 1911 Pius X., after consultation with the English bishops, issued a constitution (*Si qua est*), in which, after reciting the distribution of sees made by his predecessors Gregory I. and Pius IX., he divided the Catholic Church in England and Wales into three provinces, with archiepiscopal sees at Westminster, Birmingham and Liverpool. Westminster retained as suffragan sees the dioceses of Northampton, Nottingham, Portsmouth and Southwark. To Birmingham were assigned Clifton, Plymouth and Shrewsbury and the two dioceses of Menevia and Newport which included Wales. To Liverpool were given the sees of Hexham, Leeds,

Middlesborough and Salford. The Archbishop of Westminster and his successors were declared to be perpetual presidents of the episcopate, with the right to wear their pallium, and to be preceded by their cross in any part of England and Wales, to preside at all meetings of the bishops, and to represent them in any dealings with the civil Government of the country, having first consulted their suffragans and accepted the decision of the majority. A further development of this plan was effected five years later, when Benedict XV., by a Bull of Feb. 7 1916 (*Cambria*), erected Wales into a new and separate province, transferred the see of Newport to Cardiff, and raised it to an archbishopric, with Menevia as its suffragan.

The motive underlying this change is best expressed in the opening clause of the Bull:—"Wales, by the Celtic origin of its people, its language, customs and traditions, is so different from the rest of England that it needs, even in its ecclesiastical order, to be taken apart from the other dioceses and to be given its own hierarchy. It has been pointed out that these words are the recognition and fulfilment of a claim which was made by the canons of St. David's in the year 1145, when they petitioned Pope Eugenius III. to make Wales a distinct ecclesiastical province and to grant the pallium to its archbishop.

**The Church and Doctrine.**—The action of the Church in matters of doctrine included chiefly the continuance of her conflict with "modernism," which had been condemned by Pius X. in his Encyclical (*Pascendi*) of Sept. 7 1907. This was followed up and reinforced by a *Motu Proprio*, addressed to the whole Church (*Sacrorum Anistitium*) on Sept. 1 1910.

The Encyclical contained an elaborate exposition of the views put forward by the chief modernist writers, who for several years previously had carried on an active propaganda, mainly amongst the priests and seminarians in France and Italy and, to a smaller extent, in England and America. The ostensible object of the movement was to win recognition for a restatement of religion and the Catholic faith in such a form that it might be made acceptable to men holding the most advanced opinions outside the Catholic Church. The attention of the Pope was drawn to their utterances by several councils of bishops, and, after a full examination of their literature, the Holy See arrived at the conclusion that, in pursuing their end, they had essentially altered the meaning of the Catholic doctrines which they professed to explain. Such concepts as "religion," "faith," "revelation," "dogma," "sacraments," "authority," "the Person of Christ," were set forth in a sense alien and contrary to that which is taught by the Catholic Church. Pius X. vigorously condemned the whole system as "a summary of all the heresies" and ordered rigorous measures to be taken to secure its elimination from the fold.

The *Motu Proprio* of 1910 emphasized the decision of the Encyclical, and prescribed further steps for the exclusion of all modernist doctrines, requiring that holders of ecclesiastical offices or dignities should take an oath and make a specific profession of faith for this purpose.

In the course of the years that followed, the "modernist" movement, in view of this condemnation, practically ceased to trouble the peace of the Church. Of its three chief leaders, Father Tyrrell in England, the Abbé Loisy in France, and the Abbate Murri, who was the exponent of its political and social activities in Italy, the first died in 1909, and was buried outside the Church; the second, who had already abandoned his belief in the Godhead of Christ, was excommunicated; the third laid aside his priesthood and shared the same fate. Some friends of the movement had entertained the hope that, on the death of Pius X. and the accession of a new pope, the reprobation of their views might in some degree be modified and "the storm pass over," but one of the first acts of Benedict XV., in his Encyclical *ad Beatissimi*, addressed to the episcopate of the whole Catholic world, was to renew the condemnation of "modernism," denouncing its "monstrous errors" as a "collection of all the heresies," describing the movement in the words of Job (xxxi. 12) as "a fire that devoureth even to destruction and rooteth up all things that spring," and warning the faithful not only against its teaching but against its spirit. The effect has been to indicate that if modernism has a future it must be one that will be outside the Catholic Church.

**The Church and the Social Question.**—In relation to socialism and the economic questions which arise out of the contending claims of capital and labour, the main lines of direction to Catholic thought and action had been laid down in the Ency-

icals of Leo XIII. In these there were two chief points which entered into the Catholic position. The first was that man by nature has a right to possess private property, and that the right as natural and vested in the individual lies at the root of all social economy. The second is that the labourer has a right to a "living wage," and by this is distinctly meant a wage "sufficient to enable him to maintain himself, his wife, and children in reasonable comfort" and put by sufficient savings "to secure a small income." The noteworthy feature of this second point is that the living wage is taken as the fundamental postulate rooted in reason and justice, and not as something left at the mercy of the open market and the physical law of supply and demand. Sweating and abuses of child and female labour are condemned, and ownership, especially in land, by "as many as possible of the humbler classes" is commended and encouraged (*Rerum Novarum, De conditione operarii*, May 15 1891). To this was added a plea for shortening the hours of the labourer, especially in the mining industry, so that he might have sufficient leisure for his mental and religious development. These principles had been already set forth in more elaborate form by a Catholic society known as the Union of Fribourg, established for the study of social questions, and its annual reports and papers had been studied with interest and approval by Leo XIII.

In France the Encyclical exercised a notable influence on the direction of the leading Catholic organizations, the Jeunesse Catholique Française and the Society of Catholic Workmen founded by the Comte de Mun. It led to the formation of an important and popular organization known as the "Sillon," under the inspiration and leadership of M. Marc Sagnier. It had for its object the defence of the rights and the betterment of the condition of the labouring population based on the teaching of the Catholic Church. Circles for the study and diffusion of sound social principles were formed in all parts of France, and met with the encouragement of several of the leading bishops, notably Mgr. Mignon, Archbishop of Albi. As its following increased, its organization assumed a national or extra-diocesan importance, and large numbers of men who were not Catholics or merely nominal Catholics were attracted to its membership. In this way, from the original stage in which its members were frankly Catholics, it came to be in great measure composed of those who were content to pledge themselves as "not anti-Catholic." In this, the "Gros Sillon," the aim was to unite the workmen of all nations and all parties and all creeds in a movement of democratic progress. Its evolution of thought and teaching went to emphasize strongly not only the rights, but in many ways the autonomy of the individual, and, in the opinion of Cardinal Andrieu and several of the bishops, it had begun to verge into what seemed to be a species of modernism applied to social economy, thus committing the Church to what many deemed to be an ultra-democratic and, therefore, a party programme. In response to many and repeated complaints made in this sense to the Holy See, Pius X. in Aug. 1910 finally addressed a letter to the French episcopate (*Notre charge Apostolique*) pointing out the aspects of the later Sillonist movement which had departed from the lines laid down by Leo XIII., and requiring that the association should be brought back to its former Catholic basis, and placed under diocesan direction.

In Germany, some years before the issue of the papal Encyclical on labour in 1891, Herr Windthorst, the leader of the Centrum, had founded the great organization of German Catholics known as the *Volksverein*. It was followed in 1910 by the Congress of Christian Syndicates at Cologne which represented 360,000 workmen in Germany and 100,000 in Belgium and 100,000 in Italy. Associations for promoting the welfare of the labouring classes (*Arbeiterwohl*) and Catholic working-men's unions (*Arbeitervereine*) throughout Germany marked the growing interest and importance of the labour movement. At the same time societies were instituted on an international basis for the study of social problems, and circles were formed to encourage the reading and discussion of popular

Catholic social textbooks and literature. In eastern Germany, Cardinal Kopp, Prince Bishop of Breslau, on the occasion of his jubilee, was met by a vast concourse of Catholic workmen, marshalled in their unions, to thank him for the work he had achieved for their organization. In the west Cardinal Fischer, Archbishop of Cologne, had encouraged the same movement, albeit on more general lines. The unions in the east were of distinctively Catholic membership, while in the west Catholic workmen were often included in unions of a non-denominational kind. This difference of policy led to a considerable amount of discussion, and comparisons between what was known as the "Cologne influence" and the "Breslau influence" were much in circulation amongst German Catholics. On the one hand it was thought that the membership of Catholics would exercise a moderating influence on non-denominational associations. On the other it was felt that the strength and zeal of the Catholic unions would be best consulted by keeping them upon their own lines. In 1912 this matter was laid before the Holy See, and Pius X. addressed a brief (*Singulari quadam*) to Cardinal Kopp and the bishops of Germany in which he speaks in terms of the highest praise of the workmen's unions, and then, dealing with the point in dispute, lays it down that the Catholic unions are to be encouraged, as fostering the spirit and development of the members in harmony with their religious convictions (as at Breslau). At the same time the association of Catholics in non-denominational unions (as at Cologne) is not to be condemned, provided that due precautions are taken to safeguard their teaching by their enrolment as well in the Catholic societies.

*The Church and Canon Law.*—Pius X., a few months after his accession to the papacy, took in hand the codification of the Canon Law, a work of monumental importance to the Church, but one so difficult that many had deemed it to be impossible.

The ordinary sources of Canon Law are the canons of Church councils and the decrees of the popes, and during the ages these had accumulated to such an extent that their assortment became a task which would require many minds and many years to accomplish (see § 192). In 1151 Gratian, the monk of Bologna, had gathered together in his *Decretum* (which was not official) many of the ordinances of the Church, doing for her law something of the same service that Peter Lombard had done for her theology. Other collections of canons followed by Balbo, Gilbert, Allain, Bernard the Great, Innocent III. and Honorius III., and these materials served as the base of the great work of Gregory IX. in 1234, known as the five books of Decretals. To it were added the Decretals of Boniface VIII. (the *Sextus*) and of Clement V. (*Clementines*) and of John XXII. (the *Extravagantes*), and these, with later enactments, formed the *Corpus Juris*, which throughout the Middle Ages and to our own time has been the standard groundwork of the voluminous treatises and textbooks of Canon Law in the Catholic Church.

The Council of Trent in the 16th century, and the Council of the Vatican in the 19th, had urged the need of bringing codification of the Canon Law up to date, and several collections had been attempted by individual authors like Mgr. Martinucci and M. Wolf von Glanwell, but all of these had fallen short of what was required. On March 19 1904 Pius X. issued a *Motu Proprio* authorizing the inception of this difficult undertaking—"arduum sane munus"—and entrusting it to a commission of which the president was to be the Pope himself. The commission consisted of 16 cardinals, with 17 consultants.

Before the completion of the work the consultants numbered nearly 80, and were chosen as distinguished canonists or theologians from the various nations. A few days after the publication of the *Motu Proprio*, Cardinal Merry del Val, the Secretary of State, addressed a letter to the Catholic bishops in all parts of the world, explaining the nature of the enterprise, asking their coöperation by suggesting new points of reform or legislation, and requesting them to consult those in their dioceses who might have expert knowledge of the subject, or even to send them to Rome to help in the project. As a result voluminous communications were received from all parts of the Church, in the shape of suggestions or practical recommendations. These were duly sifted, arranged and discussed, and as far as possible adopted, and proofs and revises were transmitted to their proponents. In this way, at the cost of much labour and time, the whole episcopate throughout the world was consulted no less than three times over as to the matter and form of the forthcoming volume.

Its main characteristic was that, unlike the *Corpus Juris*, it would be not a series of collections of canons under various pontificates and

subdivided into titles and chapters, rendering the work of reference difficult except to the initiated, but, after the manner of modern codes, a single collection in which the canons are numbered consecutively throughout, while, by means of headings, the titles and chapters and the usual classification familiar to canonists have been maintained. It is thus not a *Corpus* but distinctly a *Codex* of the Canon Law. The gain in clearness of presentment and simplicity of reference is immense. The work has been not merely one of codification but in several ways, consistently with the immutability of faith and moral principle, and within the domain of methods, a modification and reconstruction of the laws of the Church to the new needs and conditions of the time. Thus in the rules of fasting, the reduction of holidays, the number of marriage impediments, the irremovability of parish priests, the election of bishops, the holding of conclaves, useful changes have been introduced. The treatment of the subject is a marvel of terseness and condensation, as the whole body of Canon Law, as far as the Church at large is concerned, is stated in 2,414 canons, and brought within the compass of a single volume of some 600 pages.

The *Codex* is the work of the best canonists and theologians in the Church, and occupied the Papal Commission for more than 13 years. Pius X., as he foretold, did not live to see its completion. It was promulgated by Benedict XV. in a constitution dated Pentecost 1917, to come into force on Pentecost of the following year. A permanent commission was created to deal with all questions affecting its interpretation. On June 28 1917, at a final meeting in the consistorial hall, a copy of the new *Codex* was solemnly presented to Benedict XV. who expressed the thanks of the whole Catholic Church to the commission, and especially to Cardinal Gasparri, Secretary of State, who from the outset had been the prime mover and chief agent in the work of codification. In the medal struck to commemorate the occasion, the Cardinal stands prominent in the group of assistants that surround the person of the Pontiff.

*The Church and Liturgy.*—One of the great measures which will make the pontificate of Pius X. memorable in the history of the Church is his reform of the Roman breviary. It altered and improved in many ways the Divine Office or chief prayer of the Church, the recitation of which occupies the clergy for about an hour and a half each day, and thus the change was one which affected the daily life of more than 200,000 secular priests, and of many religious, in every part of the Catholic world. While the main structure and composition of the Divine Office were preserved, the alterations were greater than had been made at any time since the pontificate of Pius V. and Clement VIII. in the 16th century. They went to secure the ancient practice of the Church, reaffirmed by the Councils of Trent and the Vatican, by which the Divine Office said by the clergy includes the recitation of the entire Psalter each week.

The new breviary was prepared by a commission of expert liturgical scholars whom some years previously the Holy See had appointed for the purpose. The papal constitution (*Divino Afflatu*) which brought it into force throughout the Church was issued on Nov. 1 1911. The wording of the constitution implied that further liturgical improvements in the breviary were likely to follow. The constitution for the improvement of Church music (*Motu Proprio*, Nov. 22 1903) had preceded the reform of the breviary.

A notable liturgical event was the solemn celebration of Mass according to the Greek rite in the papal chapel in presence of the Pope on the centenary of St. John Chrysostom on Feb. 12 1908.

*The Church and the Eucharist.*—Amongst the acts of the Holy See during 1910-20 there were innumerable decrees and briefs, issued to encourage prayer and to foster the spiritual life of both clergy and people. The great movement known as the "Eucharistic Congress" was held each year with great success in one or other of the chief capitals of the world, and in centres like Paris, London, Madrid, Montreal and Jerusalem. To these the Holy See gave the highest sanction by sending a papal legate to preside over the solemnities.

The most noteworthy development in the matter of devotional practice was the decree of Pius X., Aug. 8 1910 (*Quam singulari*), ordering that little children from their seventh year should be admitted to Holy Communion. For this permission the Pope received the thanks of the clergy and of children and parents from every country throughout Catholic Christendom.

*The Church and Scripture.*—During the same period the action of the Church in regard to Holy Scripture led to three important undertakings. In the earlier part of the pontificate

of Pius X. a standing commission had been organized at Rome, composed of leading biblical scholars, to deal with problems of biblical research. The commission has issued reports from time to time in the shape of conclusions on biblical questions of the day, and these are published by the Holy See for the information and guidance of Catholic professors of Scripture and of Catholics generally. In 1912 there was opened at Rome the Biblical Institute (founded by Pius X. in 1909). It was placed under the fathers of the Society of Jesus, and its object is to serve as a home of biblical research and as a training school for those who devote themselves to the study of the Bible. This project met with a cordial response, and one family alone contributed £200,000 (five million francs) towards its foundation. In Aug. 1916 Benedict XV. confirmed the act of foundation, and laid down rules for procedure.

In 1907 the Holy See undertook the great enterprise mooted by Sixtus V., to discover and determine the exact text of the Vulgate edition of the Bible, as it left the hands of St. Jerome. It involves the patient labour of many expert scholars, and research in many of the libraries of Europe, and the collation of their variant readings, so that long years and many lives will have to be spent before its aim can be accomplished. The work was confided to the Benedictine order, and was installed in the Palazzo di San Calisto, in Rome, being presided over by Cardinal Gasquet, Prefect of the Vatican Archives. On the centenary of St. Jerome, Benedict XV. issued a Bull of commendation, and in 1921, at the Catholic Biblical Congress held at Cambridge, in England, Cardinal Gasquet described the nature of the task, its importance to the Church and to European scholarship, and the progress made during the last 13 years. It may be added that Benedict XV. in Oct. 1914 issued a letter of approbation and encouragement in favour of the Society of St. Jerome, which has for its object the circulation of vernacular editions of the Gospels amongst the masses of the people.

*The Church and the War.*—During the World War the attitude of the Catholic Church was both national and general. In each of the belligerent nations Catholics were free to give full expression to their patriotism, and to throw themselves cordially into the cause of their country, and under their bishops and clergy prayers were continually offered and services held in their churches in supplication or thanksgiving for victory. The Holy See itself, as super-national and having its spiritual subjects in all countries, was bound by its position to observe an attitude of neutrality in the sense of impartiality, and to confine its action to the promotion of peace and the alleviation of suffering. Pius X. endeavoured up to the last moment to avert the outbreak of hostilities, and on Aug. 2 1914 caused prayers to be said in every parish throughout the whole Church for peace and good-will amongst the nations. A month after the declaration of war—Sept. 8 1914—his successor, Benedict XV., made it the first act of his pontificate to issue an exhortation to Catholics throughout the world "to leave nothing undone to put an end to the calamity." In Nov. of the same year he addressed an Encyclical to the whole Catholic episcopate, commanding them and their flocks to implore the Author of Peace to still the tempest. In Jan. 1915 the Pope composed and issued a form of prayer for peace to be translated into all languages, and ordered that on Feb. 7 all Catholics in Europe, and on March 21, all outside of Europe, should assemble in their churches in a joint act of supplication. He himself, attended by his court, recited this peace prayer in St. Peter's with a congregation of 30,000 people. In 1915 the perpetual recitation of the Rosary was enjoined and all Catholic priests throughout the world were asked to offer mass for the same purpose.

In Dec. 1914 the Pope endeavoured to induce the belligerent Powers to consent to a truce at Christmas, but failed to obtain their assent. In his allocution of Jan. 22 1915 he pleaded especially against the devastation of the occupied territories. On May 26 1915, when the submarine and aeroplane terror had already commenced, he issued a letter deploring "the use on sea and land of methods of offence which are contrary to the laws of humanity and to international right," and imploring

the rulers of nations to adjust their quarrels "by reason and by conscience and by generous goodwill." On July 28 of the same year he made a similar appeal to the statesmen of the combatant nations. This method of public exhortation was the only means left to the Holy See to advocate peace, as a secret treaty (London, April 26 1915) had been signed by Great Britain, France, Russia and Italy, by which these Powers consented to the request of Italy that no representative of the Holy See should be allowed to take diplomatic action towards the conclusion of peace, or the settlement of questions arising from the war (Art. 26).

In the consistory of Dec. 4 1915, and again on Dec. 24, Pope Benedict renewed his condemnation of the spirit of hatred engendered by the war and his protest against the cruel persecution of the Armenian people. He regretted that his appeal for peace to the belligerents, although received with all reverence, had failed to secure its object. On Feb. 9 1916 the Pope received an address representing three millions of Jews in the United States, and expressed his sincere desire that in all matters they should be treated with fairness and equity. In the consistory of Dec. 4 1916 the Pope spoke of the iniquities and cruelties of the war by sea and by land, by deportations of civilians, and air raids on open towns, and said: "We brand once more with our reprobation all the atrocities committed in this war, whosoever they have taken place, and by whomsoever they have been perpetrated." In response to a petition from the cardinals, Benedict XV. once more appealed to the rulers and peoples of the combatant countries to foster the spirit of goodwill, by which alone peace could be restored.

In Aug. 1917, at a time when the struggle appeared to many to have reached a hopeless *impasse*, he went further and addressed a diplomatic note to the belligerents, suggesting the outlines on which at least preliminary conditions of peace might be considered. These were that there should be reciprocal condonation as to the costs of war; that Germany should evacuate Belgium and guarantee its complete independence in the future, and also evacuate all French territory and possibly receive in return her lost colonies; that all disputed territory between Germany and France (Alsace and Lorraine) and between Austria and Italy (the Trentino and Trieste) should be arranged by mutual consideration and conciliation. The argument of the note was that, whatever loss either side might suffer by such an arrangement, it would be immeasurably less than that involved in the sacrifice of life and treasure by the continuance of the war. Respectful replies were made to this note by Belgium, the United States, Japan, Germany, Austria and Turkey in writing. England answered orally by her envoy at the Vatican; and France, who had no representative there, is said to have tacitly or privately adhered to the British response. All appreciated the good intentions of the Pope as a peacemaker, but the hour for overtures had not yet come. One result of the note was that the British Government desired to be informed more definitely as to the intentions of Germany in regard to Belgium. The papal nuncio at Munich thereupon asked the German Chancellor Michaelis, and obtained precise information on the point, and Cardinal Gasparri transmitted to the British authorities the replies of the German and Austrian Governments, and offered, in case that the answer given should seem to furnish to the Entente Powers a basis of mediation, to obtain any fuller information that they might desire. The Allies apparently found that no sufficient basis existed, and the matter proceeded no further, but at the end of 1917, and previous to the great offensive of the German army, the Pope once more addressed to the Central Powers a strong entreaty to desist from methods of warfare which are contrary to international law. On May 22 1918 he wrote to Cardinal Ferrari of Milan a letter explaining and justifying the attitude of the Holy See during the war, and replying to the manifold ways in which it had been misjudged or misrepresented.

The action of the Pope in regard to those who suffered by the war was first of all directed to making provision for the spiritual welfare of the armies engaged. In concert with the episcopate of

the belligerent nations and the military authorities, the Holy See caused to be organized the body of chaplains who were to accompany the troops, and invested them with the fullest powers for the discharge of their ministry. In most cases an *episcopus castrensis*, or field bishop, was appointed to preside over the chaplains of each country. Societies were formed for the equipment of the chaplains, and more than 10,000 portable altars with consecrated altar-stones for the celebration of Mass were placed at their disposal. Prayers and Masses for the fallen were offered throughout Catholic Christendom.

As early as Dec. 1914 the Pope established in the Vatican an information office with a view to enable the relatives of prisoners-of-war to ascertain their address. In Oct. of the same year the Pope wrote to Cardinal Hartmann of Cologne to urge him to use all his influence to secure better treatment for the prisoners in Germany. He wrote also to the bishops of places where prisoners were interned to see that priests speaking their language should visit them, encourage them to write to their families, and if need be defray the postage. In Sept. 1915 the Pope obtained from Germany the suppression of the camp for air-raid reprisals at Neuenkirchen. At the same time he obtained an assurance from all the Powers that prisoners-of-war should not be forced to work on Sundays. He sent in 1917 a special delegate to visit the prisoners in Germany, charged to see, if possible, the prisoners alone, and to report to the Holy See on their treatment. At Easter 1916 the Pope sent presents to be distributed to the English prisoners in Turkey. In May 1916 he obtained the transfer of a number of English prisoners from Germany to the hospitals of Switzerland, and received the cordial thanks of the British Government and a letter of thanks from the prisoners themselves. He procured in 1918 the liberation of Dr. Beland, former Canadian minister, who had been for four years a prisoner in Germany. He also charged his nuncio at Vienna to find homes in the country for the children suffering from want of food.

In 1916 a commission of Austrian priests made inquiries into the atrocities perpetrated in Belgium and drew up a report damaging to the Germans. The Archbishop of Vienna courageously read the report publicly from the pulpit, whereupon the Austrian Government, at the instigation of its ally, wrote to the Pope asking that the archbishop should be made to resign. The Pope categorically refused. He received in the following year a letter of thanks from King Albert for the help and sympathy given to Belgium throughout the war. The Holy See had sent 100,000 francs for the starving children in Vienna, and 50,000 francs for the children and prisoners in Belgium, and a larger sum to be distributed to the sufferers in the devastated regions in France. At the same time, he received the thanks of the Belgian Government for obtaining the reprieve of more than 50 persons who had been condemned to death by the Germans. He was able at the same time to procure from the German headquarters the liberation of a large number of French prisoners and the repatriation of civilians from the northern districts of France. His intervention was equally successful in obtaining from the Austrian Government the release of a considerable body of Italian prisoners-of-war.

Immediately after the conclusion of the Armistice the Holy See communicated with the several Powers and urged the speedy liberation of the prisoners that remained in their hands. In Aug. 1918 the Pope, in response to a petition from 200,000 war widows in France, celebrated Mass for their husbands, in the presence of a large pilgrimage from their number sent to Rome for the occasion. The fund which Benedict XV. organized throughout the Church in behalf of the starving children in the countries ruined by the war had early in 1921 reached the sum of more than 11,000,000 lire (then about £160,000).

Amongst the chief authorities on which the above article is based are the official reports of the Holy See, the *Acta Apostolicae Sedis*, the *Annuaire Pontifical* of Mgr. Battandier, and the volumes of the *Documentation Catholique*. (J. Mo.)

### III. THE FREE CHURCHES

*Doctrinal*.—The disquietude caused among the Free Churches in Great Britain by the "New Theology" movement (1907) had no long life or lasting effect. At the Congregational Union meeting in Nottingham in Oct. 1911, Principal Forsyth and Rev. R. J. Campbell, who had figured most prominently in the controversy, appeared on the same platform. In 1926 Mr. Campbell was ordained into the ministry of the Anglican Church, and withdrew his book from publication. The attacks on the historicity of Jesus, put forward by A. Drews in Germany and J. M. Robertson in England, were met with thoroughness and skill, especially by Dr. Estlin Carpenter, of Manchester College, Oxford. The question of miracles, brought into prominence by the Rev. J. M. Thompson, of Magdalen College, Oxford, led



to some discussions, but neither it nor Dr. Schäfer's utterances on the origin of life (British Association, Dundee 1912) stirred the waters to any extent. The general position of biblical scholarship is well illustrated by *Peake's Commentary on the Bible*, to which not only Free Churchmen but several Anglicans contributed. Dr. Buchanan Gray has (continuing the work of Dr. Driver) provided a monumental commentary on *Job*. Perhaps the outstanding work on theology is Dr. R. S. Franks' *History of the Doctrine of the Work of Christ* (1918). Popular clamour during the war against German theological works had no echo among scholars. The younger men were becoming busily concerned with the application of the Gospel to the conditions of the post-war world; their activity is illustrated in *The Christian Revolution* series and the publications of the Student Christian Movement. Two books by Dr. T. R. Glover, of Cambridge, *The Jesus of History* and *Jesus in the Experience of Men*, have had a wide circulation.

There is no disposition among those churches that dispense with formal creeds to introduce anything of the kind, and where confessions are already in existence the tendency is to modify and adjust them, or to regard them as declaratory rather than binding. Thus the English Presbyterian Church has revised the statement of Church principles made at the ordination of ministers, and the form of the questions put to the candidate, the aim being to lay more emphasis on the minister's message and less on his theory. Similar steps were being taken in 1921 by the U.F. Church in Scotland. On the other hand, proposed unions of Methodists, Presbyterians and Congregationalists in the dominions involve the last-named denomination in a confession or creed, or at least a statement of faith which in most cases would be accepted for the sake of union. The war gave rise to some discussion on prayers for the dead, and it may be said generally that the old rigidity has given way here to a more open-minded spirit. It is sufficient merely to mention other discussions raised by the war—providence, patriotism, conscience, reprisals, eschatology—which found expression in books and still more in pamphlets.

*Union and Federation.*—Looking for a moment to the overseas dominions, which in so many ways have developed their impact on the home land, far-reaching movements had come by 1921 into operation. The Baptists, indeed, stoutly maintained their distinctive witness, and were disinclined toward schemes of amalgamation. But both in Australia and Canada Presbyterians, Methodists and Congregationalists were steadily approximating. The first-named Church, not so unanimous as the others, did not give a sufficiently decisive vote in Australia in the autumn of 1920, but negotiations, accompanied by a large measure of coöperation, still continued. In Canada also the Presbyterians had been the most cautious, but in June 1921, by a majority of about 400 to 100, they agreed to union with the other two bodies. In New Zealand Congregationalists were being absorbed into the Presbyterian Church. In the mission fields, especially in South India and to some extent in China, the movement was much more successful, and included Episcopalians. In East Africa the Kikuyu controversy (in which the Bishop of Zanzibar dissociated himself from his brethren of Mombasa and Uganda for their fellowship with non-Episcopal missionaries in an attempt at union in face of Moslem aggression) created some unpleasantness, but a *modus operandi* was found. In Great Britain, apart from Scotland, it cannot be said that any new organic union was in 1921 actually in sight. For some years past the three next Methodist connexions (Wesleyan, Primitive and United) had been exploring avenues to union. Among the difficulties were the proportion of lay to clerical representation in Conference, and the relative priority of representative and pastoral sessions. Some Wesleyan leaders felt that the contemplated union might prejudice the case for the larger union. It seemed possible that Primitives and Methodists might come together apart from Wesleyans, but probable that patient continuance would secure the triple bond.

Meanwhile the overlapping of Free Churches in smaller towns and villages made for weakness, and caused concern to the

leaders of the different denominations; and it was with the design of securing closer coöperation that Rev. J. H. Shakespeare, when president of the National Free Church Council at Bradford, 1916, propounded a scheme for federating the Evangelical Free Churches of England, which was afterwards accomplished. The federation differed from the National F.C. Council in that its executive members were appointed by the conferences or assemblies of the different communions, and its aims and objects were specifically moral and spiritual. Alongside this there was increasing coöperation in the mission field, in social service and in the training of ministers, especially in the theological faculties at London and Manchester. One of the most impressive demonstrations of the Free Church unity was the thanksgiving service after the Armistice, in the Albert Hall, London, at which the King and Queen were present.

*Relations with the Anglican Church.*—In spite of some tension caused by the question of Welsh disestablishment and the commemoration in 1912 of the ejection of 1662, there was between 1910 and 1920 a decided growth of sympathetic and amicable feeling between the Anglican and the Free Churches and no small amount of coöperation. British Nonconformists still believed that they were entitled to more real recognition at State festivals, and valued the fellowship exemplified at the installation of the Prince of Wales at Carnarvon in July 1911. In the academic world, churchmen of all denominations worked together in harmony and full trust on the theological boards of the newer universities; and the removal of the restrictions on divinity degrees at Oxford, Cambridge and Durham was warmly appreciated. The placing of a Bunyan memorial window in Westminster Abbey, and its joint dedication by the Dean and representatives of the Free Churches, was a happy sign of the time. During the war, chaplains of both sides learned to appreciate each other and worked happily together, and the same stress did much to bridge the chasms at home. United services of intercession and thanksgiving were frequent, and created a new sense of fellowship. The action of the Bishop of Hereford (Percival) in inviting Nonconformists to a coronation communion service in the cathedral in 1911 was in advance of common Anglican sentiment, but the fact that Dr. Jowett preached in Durham cathedral in 1920 (at the invitation of the bishop, Dr. Moule), and Bishop Weldon, Dean of Durham, in Westminster chapel in 1921 was significant. The Lambeth proposals indeed rather depreciated any such pulpit exchanges, though it might seem, as Dr. Wallace Williamson intimated to the Archbishop of Canterbury at the Church of Scotland Assembly in May 1921, in the light of Scottish experience, that they pave the way to union more surely than theoretical discussions.

The Lambeth proposals were discussed in nearly all the "supreme courts" of the Free Churches and by the Federation of Free Churches, and received sympathetic and friendly consideration. Free Churchmen were not slow to indicate certain ambiguities of utterance in the proposals and to assert the impossibility of accepting reordination. But in 1921 they were coming to see that the Lambeth proposals were not an ultimatum so much as an appeal to "come and reason together." It was possible that along the line of this idea of "extended communion" the difficult question of reordination might be avoided. It was great gain that the proposals did not contemplate the absorption of non-Episcopal communions in the Episcopal fold, but the Anglican leaders had hardly yet made that detailed study of the history and principles and genius of nonconforming Churches that seemed essential to any realization of their suggestions. Many Nonconformists would require a readjustment of the relations of the Anglican Church to the State, and many more looked askance at any proposal involving relationship with the Roman or Greek Churches. Meanwhile there were abundant opportunities for united service which did not entail the least abandonment of conviction and principle on either side. In the mission field, in theological study and in social service, there was already manifest in 1921 a degree of coöperation and fellowship which was full of promise for the consummation of a unity that need not be confounded with uniformity.

The World Conference on Faith and Order, propounded by American Episcopalians, and temporarily frustrated by the war, was sympathetically considered by Free Churchmen. A preliminary meeting held at Geneva in Aug. 1920 attracted 120 delegates from 40 countries. A continuation committee of 35 members was appointed.

*Modifications of the Independent Position.*—In the Baptist and Congregationalist denominations the decade 1910-20 was perhaps the most important in their history. Great movements in thought and action transformed both the polity and the position of these communions. The movement in thought may be summed up by saying that they had come gradually to realize that Independency, pure and simple, as it was understood and practised in earlier days, was no longer sufficient to meet the conditions of modern religious life. And the main movement of polity was in line with that of the world as a whole in substituting the ideal of interdependence for that of independence.

This movement of thought found expression in two or three main directions. In the first place it was generally recognized by 1921 that the training, the appointment and the proper support of the minister was not the concern of the individual church only but of the whole denomination. This recognition led to the raising of sustentation funds of £250,000 in each case. The object of the funds was primarily to secure to every accredited minister a minimum stipend adequate for his support, but inevitably the scheme could not stop there. If the denomination accepted responsibility for the support of the minister, it followed logically that it must have some voice in his training and appointment. Not much had yet been done up to 1921 towards a reform of the college system, though a beginning was made by the creation of a united collegiate board in each denomination and further advance was inevitable in this direction. But in the matter of ministerial appointments the scheme introduced radical changes into the old Independency. It combined provision both for sustentation and settlement. Churches were still left free to call anyone they chose as their ministers, but grants from the sustentation fund were conditional on their choice being approved by the executive committee of the fund.

Another important provision of the Baptist scheme was that all appointments to the pastorate of aided churches should be for a definite term of five years, and then should automatically cease unless renewed by the express invitation of the church, with the consent of the executive committee.

With the introduction of these changes it speedily became clear that the responsibility of the denomination for the ministry could not end even here. If all pastorates were to end automatically after five years, there must be some central organization, like the synods of the Connexional Churches, to secure other pastorates for the ministers thus out of charge, and to maintain them during the time they were out of office. Accordingly the system of general superintendents was introduced. The country was divided into 10 areas, with a general superintendent in charge of each, whose duty it was to visit the churches, to advise them in their perplexities, and, in concert with the other superintendents and the executive committee, to arrange for the resettlement of ministers at the expiration of the term of their pastorates. This part of the scheme, which introduced the most important change into the older Independency, was an unqualified success. While still leaving the churches full liberty in the management of their own affairs, it completely solved the problem of ministerial settlements which was one of the most serious questions in earlier days.

The Congregationalists had in 1921 not yet gone so far as the Baptists, who in their general secretary, Dr. J. H. Shakespeare, had an ecclesiastical statesman of rare gifts. They did not subject the aided pastorates to a five years' term, but they divided the country into nine similar provinces with a moderator in charge of each, whose functions and duties practically coincide with those of the Baptist superintendents. This scheme was only launched in Nov. 1919, but had already justified itself by 1921.

*The World War.*—The Free Churches of Great Britain bore their full share in service during the World War. In earlier

days Presbyterians (through the Church of Scotland) and Wesleyans alone had any army chaplains or army work. But when the men of the Free Churches entered the British forces by myriads, provision had to be made to meet their spiritual needs. Under the leadership of Dr. Shakespeare a United Navy and Army Board was formed by the Baptists, Congregationalists, Primitive Methodists and United Methodists, to appoint chaplains to the members of these four denominations. No fewer than 320 chaplains served with the forces in the home camps and all theatres of war, many of whom were awarded high distinctions. After demobilization the board remained, and was in 1921 represented by five permanent chaplains.

With the great increase in the cost of living the lower stipends of ministers in all denominations became quite inadequate. Local effort was often unequal to the task of rectifying this, and denominational machinery had to come to the rescue. The fall in foreign exchanges due to the high price of silver in 1919-20 put a heavy burden on the missionary societies and led to much hardship in the foreign fields. Generally speaking the situation was met with courage and zeal. The Baptists, e.g. in six months in 1920 raised a new fund of £270,000, of which half was for the relief of the missionary society and half for increasing the minimum stipends of the home ministry. The Congregationalists were in 1921 promoting a fund of £500,000 for similar purposes, and especially for a superannuation scheme. Methodists and Presbyterians were similarly diligent. With the fall in the price of silver the foreign aspect was improved.

The war brought other difficulties. The revelations made in the survey published under the title of *The Army and Religion*, as to the relative ignorance in spiritual matters of men of all denominations, caused much heart-searching. In church circles, as in other departments of the nation's life, there were disappointment and disillusion. Neither war nor peace had brought the millennium. The churches were not filled. The theological colleges, depleted and generally closed during the years of war, were by no means filled again afterwards. For some years there had been no adequate output of ministers, and the outlook was not bright in 1921.

The Society of Friends, with its particular peace testimony, met the situation of war in its own way. While many of its young men suffered as conscientious objectors, others embraced dangerous non-combatant service such as mine-sweeping; many more were engaged in Red Cross work, and the Society as a whole did invaluable work in repairing waste places, assisting in the restoration of villages and lands, and in combating disease and famine in Allied and (since the war) in enemy countries alike.

One curious effect of the war was that Nonconformists became much more familiar with liturgical forms of service. The many united services of intercession and thanksgiving were responsible for this, and it was significant to note the number of new manuals issued, containing systems of common prayer and praise. Presbyterians, Congregationalists and Methodists alike were drawn into this movement. The elasticity of the Free Churches was well illustrated by the ministry of Dr. Orchard at the King's Weigh House chapel, London, where a full-blown liturgy was in use long before 1921 and a high sacramental practice followed. Dr. Orchard was also the leader in what is known as the Free Catholic movement.

*Other Denominational Activities.*—Two great ecumenical conferences were held in 1911, both in America. The Baptists met at Philadelphia; one of the most striking features of the gathering was the presence of a group of ministers from Russia and S.E. Europe, where the Baptist cause was making phenomenal headway. The war played havoc with this progress, but afterwards there were indications once more of reconstruction and growth. The same may be said of the Presbyterians of Hungary and Transylvania, who suffered additionally by the unsympathetic action of Rumanian officials. Methodists of all shades met at Toronto in 1911. The war prevented these international gatherings for some years, but Congregationalists held their Fourth International Council at Boston in 1920, and Presbyterians met in Pittsburg in Sept. 1921. Another noteworthy

Methodist event was the opening of the new Wesleyan Church House in Westminster (Oct. 1912), as the headquarters and focus of the multiple organization of the Connexion. It is an outcome of the million-guinea fund raised at the beginning of the century and is a monument of the unwearrying care and ability of Sir Robert Perks. The Wesleyans in 1921 also established a theological college at Cambridge.

In 1912 the Congregationalists, and to a less extent the Baptists, Presbyterians and Unitarians, celebrated the 250th anniversary of the Act of Uniformity and the consequent ejection of 2,000 ministers (1662). Here and there the occasion was used somewhat aggressively against the Anglican Church, but on the whole attention was drawn to the positive lessons of the ejection, fidelity to conscience, and the dawn of the modern idea of a free Church in a free State. In 1920 the tercentenary of the Pilgrim Fathers was widely celebrated in England, Holland and America.

In this connexion may be mentioned a notable crop of sound historical research in which most of the Free Churches have taken part, and which contrasts favourably with the comparatively uninforming productions of past generations. For Elizabethan Puritanism and Separatism we have the work of Mr. Champlin Burrage and Dr. Albert Peel, while Rev. W. Pierce has done much to clear up the Marprelate mystery. Rev. Ives Cater that attaching to Robert Browne, and Rev. W. H. Burgess has investigated anew the story of John Smith, "the Se-Baptist," and of John Robinson. As regards the 17th century, the Rev. B. Nightingale has pointed the way to a very necessary revision of Calamy's story of the ejected ministers, and brought to light many facts respecting Cumberland and Westmorland, and Prof. Lyon Turner has made a special study of the indulgences granted in 1672. Prof. Alex. Gordon is another diligent worker in this field. Mr. W. C. Braithwaite has written a standard history of early Quakerism in England, and Dr. Rufus Jones has performed a similar service for America. Rev. H. W. Clark has produced a comprehensive history of Non-conformity in two volumes. Dr. Rendel Harris has been indefatigable in his researches into the history of the "Mayflower," that carried the Pilgrims to New England, and has brought to light very interesting information. It is even suggested that part of the ship itself is preserved in the timbers of a barn at Jordans, in Buckinghamshire.

**Statistics.**—The Free Churches in the United Kingdom had to admit a falling-off in their figures during 1910-20. For several years prior to the war most of them, especially Baptists and Wesleyans, had to lament an annual decline in numerical strength. The Welsh revival of 1904-5 brought into the churches an immense number of recruits whose stability proved to be in inverse ratio to their enthusiasm, and many quickly fell away. This accounted for much of the decrease; emigration and the movement from the rural to the urban districts were other causes. People change their residence more often than of yore, and are not always careful to transfer their membership. The increase of Sunday pleasure and the general "spirit of the age" have also to be taken into account. The incidence of the war made the compilation of statistics very difficult, and even in 1921 the machinery was not in proper working order. There were indications, however, that pointed towards a cessation of the decrease and in some quarters towards an increase. The figures given in the following schedule are but an approximation. The meaning of the term "members" varies to some extent in the different denominations, and some of the returns are a year or two old.

	Ministers	Members	Sunday Scholars
Wesleyan Methodists	2,768	489,870	849,861
Congregationalists	2,883	451,229	608,796
Baptists	2,061	380,357	481,128
Primitive Methodists	1,095	206,372	224,452
United Methodists	709	138,921	264,113
Calvinistic Methodists or Welsh Presbyterians	961	187,575	191,295
Presbyterians (Eng.)	390	84,232	67,139
Society of Friends	..	18,753	17,222
Independent Methodists	387	8,468	25,192
Unitarians	338	..	28,330
Churches of Christ	..	13,310	15,702
Countess of Huntingdon's Connexion	34	1,933	2,736
Moravians	39	5,539	4,162
Wesleyan Reform Union	16	8,506	21,978

The Salvation Army returns 9,635 corps, circles and societies; 17,288 officers and cadets; but gives no returns as to adherents. In Ireland the (disestablished) Episcopal Church claims about 600,000 of the population, the Presbyterians 450,000, the Methodists 65,000. Congregationalists and Baptists are very thinly represented.

**Allied Organisations.**—The *Brotherhood* movement, in some places known as the P.S.A., was particularly hard hit by the war, and was still finding reconstruction difficult in 1921. But a great opportunity was there for these services, brief and bright, where addresses are given on Bible subjects or on themes of current interest from the Christian point of view, much stress being laid on the obligations of Christian citizenship. The movement has spread to the continent of Europe, and has much success in Canada. The *Adult Schools*, a much older institution, and one in which Friends have been particularly active, have been hampered by the lack of suitable local leaders and class teachers, but exercise a very potent influence through the men who meet usually on Sunday mornings about nine o'clock. *Sunday Schools* have suffered in the number of scholars, but the quality of the work done is rapidly improving, as better methods of grading and instruction are introduced.

The Y.M.C.A. found its great opportunity in the war. By its operations at first in the home camps and then by invitation in N. France, and subsequently in every field of war, near and far, it led the way in ameliorating the lot of the soldier. It gained the good will of men in the field and their relatives at home, of Government and of employers of labour. Its after-war programme, somewhat ambitious, like that of many another concern, was checked by trade depression and financial stringency, but its Red Triangle Clubs did good work.

The *Student Christian Movement* is one of the most vital Christian agencies in existence, and affords a happy meeting ground for the educated youth of all the churches. It has widened its earlier scope, when it was chiefly concerned with foreign missionary aims, and is now placing alongside those the claims of social service at home. It is increasingly powerful in other countries, and held an important international gathering at Glasgow in Jan. 1921.

The *British and Foreign Bible Society* and the *Religious Tract Society* are the willing handmaids of all the churches. They too did excellent work during the stress of war, and continued it afterwards, though hampered by the high cost of production. In March 1911 the 300th anniversary of the issue of the English Authorized Version was worthily commemorated. With regard to Bible revision, a number of Free Church scholars issued a manifesto in Oct. 1912 stating that, in their opinion, the time was not ripe in view of the work yet to be done in getting an approximately true text of the original Hebrew and in utilizing recent linguistic discoveries affecting New Testament Greek. A number of them also joined with representative Anglican scholars in a public protest against the issuing of the revised Bible of 1881-5 without the reviser's marginal readings. A new translation of the New Testament by Prof. J. Moffatt, of the United Free Church College, Glasgow, has gained high appreciation and wide use. (A. J. G.)

IV. THE PRESBYTERIAN CHURCHES OF SCOTLAND

In Scotland, apart from the relation of the World War to religion and the churches, the most prominent question between 1910 and 1921 was a possible union between the Church of Scotland and the United Free Church. These two communions embraced nine-tenths of the church members in the Northern kingdom, and thoughtful men on both sides had long been anxious for closer fellowship in the face of decreasing rural populations and the increasingly serious problems of the cities and large towns. Holding the same standard of faith and order these two great wings of Presbyterianism had practically everything in common except the State connexion. Patronage in connexion with ministerial appointments which led to the disruption in 1843 ceased to operate in the Established Church a generation ago and thus a great stumbling-block was removed. The Union of the Free Church and the United Presbyterian Church in 1900 was a predisposing cause to the thought of a larger union, and in 1910 the two Assemblies (Established and United Free) appointed committees to confer on the causes which keep the two Churches apart. These causes were not primarily connected with doctrine, discipline or worship, but with the spiritual independence of the Church, its freedom from parliamentary interference with doctrine, discipline and worship. The United Free Church felt that, in spite of the absence of any conflict between Church and State in Scotland for 70 years, the decisions reached by Lord Brougham's judgments in the Disruption cases held the field, and witnessed to the State's claim to be omnipotent in the spiritual as in the secular domain. In 1912, in a document known as the Memorandum, the Church of Scotland committee gave a new turn to the matter by suggesting: (1) that instead of the State

conceding spiritual liberty to the Church and prescribing its limits, it was for the Church to formulate and assert its own liberty and prescribe the limits within which it claimed freedom from external interference; (2) that instead of disputing over the terms establishment and disestablishment an attempt should be made to put the Church in a relation with the State not inconsistent with the historical ideals of either church. With the coming of the war, active negotiations were suspended, but the years of strife brought the two churches very closely together in many practical ways, e.g. in the temporary amalgamation of the divinity colleges, and in local parochial and congregational arrangements. With the advent of peace, the lines of the Memorandum having been already generally approved in both churches, a new step was taken by the formulation of a series of Draft Articles declaring the constitution and liberties of the Church. The United Free Church held that it was for the Church of Scotland alone to straighten this matter out with the State, and though it approved the Draft Articles as formulated it would not join in any approach to Parliament with a view to legislation. The Government was well disposed and in 1921 introduced and carried through a bill to give effect to the Draft Articles. The bill did not, of course, unite the two churches, but it was a step towards union. Opposition to it came from both sides. There were those in the Church of Scotland who said that it meant virtual disestablishment, and changed the whole nature of the Church's position in the State. On the other hand there was a body of opinion in the United Free Church, which saw in the bill rather the reestablishment of the Church of Scotland, the retention of all its exclusive privileges, e.g. as to royal and Indian chaplaincies and university divinity chairs. Nor did this bill touch the tithes or tithes endowments. It must be remarked here that the United Presbyterian Church had been strongly voluntary, and that the Free Church, though it had not disrupted on this point, had also by the time of the Union in 1900 come to be a staunch supporter of the cause of disestablishment and disendowment. The bill of 1921 was to be followed by legislation dealing with the tithes and until this question of the patrimony of the Church of Scotland was settled there could be no technical negotiations for union.

The question of the tithes had come up in another connexion. Stipends of parish ministers in Scotland were regulated according to "fiars," i.e. the prices of grain legally struck or fixed at an annual court in each shire. During the war these prices rose enormously. The ministers found the result as agreeable as the heritors found it irksome, and considerable discussion (culminating in a Parliamentary bill introduced—and withdrawn—in the autumn of 1920) took place on attempts at compromise.

At both the Church of Scotland and the United Free Church Assemblies in May 1921 the Lambeth proposals were submitted in person by the Archbishop of Canterbury and the Bishop of Peterborough. These prelates were very heartily received and sympathetic replies were given by representative leaders. The official response of organized Presbyterianism was given at the Pan-Presbyterian Council, meeting in Pittsburg, U.S.A., in Sept. 1921. A joint conference of Anglicans and Presbyterians, meeting in Montreal during the spring of 1921, unanimously agreed on forms of service by which "extension of communion" might be given to and by the respective parties, but this agreement was personal rather than official.

In the matter of social problems and social service both churches have been active. The Church of Scotland appointed a commission on the war, and the result of its inquiries was a valuable survey entitled *Social Evils and Problems*, prefaced by a statement on "The Ethical Mission of the Church" by the Rev. Prof. W. P. Paterson. That the same church was alive to the needs of the hour was evidenced by the appointment in 1920 of a committee to inquire into the recrudescence of spiritualism. In the temperance campaign which preceded the first series of elections on the Local Option issue, the United Free Church was, as might be expected, more unanimous and energetic than the Established, though some powerful champions were found in the ranks of the latter. One particularly interesting scheme in which

both churches were uniting in 1921 was a memorial to Scottish soldiers who fell in Palestine. This was to take the shape of an Archaeological Research school in Jerusalem with a Scots kirk attached. The two churches also cooperated in the endeavour to rebuild the broken life of their coreligionists in central and south-eastern Europe and to reestablish mission work in Palestine and Syria, where the new conditions had entirely altered and complicated the situation. The churches gave of their best during the war in combatant and non-combatant and remedial services. The noteworthy volume entitled *The Army and Religion* owed much of its value to the editorial skill of Dr. D. S. Cairns of the Aberdeen U.F. College. The Scottish churches, like others, had not up to 1921 been receiving the recruits for the ministry that were expected on the cessation of war, and the position seemed likely to become acute in a few years' time. Even if the projected Union was accomplished, the experience of the United Free Church since 1900 showed that it would be a matter of some difficulty to get local congregations to unite even in places where all could be well accommodated in one building.

Among the smaller Presbyterian churches, the Free Church remained vocal, but made little progress and found it increasingly difficult to get ministers. Its chief strength was in the Highland and Western Islands. The Free Presbyterian Church, the Reformed Presbyterian Church and the Synod of United Original Seceders remained stationary.

The following figures give some idea of relative strength in Scotland:—

	Ministers and Evangelists.	Churches and Halls.	Church Members.	Sunday Scholars.
Church of Scotland . . . . .	1809	1704	728,239	192,496
United Free Church . . . . .	1707	1534	528,084	201,014
Free Church . . . . .	88	165		
Episcopal Church . . . . .	350	410	56,000	
Congregationalists . . . . .	183	183	36,615	26,909
Baptists . . . . .	117	149	21,537	18,462

Further particulars, also those relating to the smaller Presbyterians and to the Wesleyans and Primitive Methodist Churches, will be found in the respective year books and in the *Scottish Church and University Almanac*. (A. J. G.)

V. CHURCHES IN THE UNITED STATES

The most accurate statistics for the religious bodies of the United States in 1920 were undoubtedly those published by the Federal Council of the Churches in the *Year Book of the Churches*, the figures being so far as possible those reported by the church bodies themselves. Unfortunately, the progress made during the decade 1910-20 cannot be measured precisely, for trustworthy statistics are not available for 1910; the nearest approach are those of the U.S. religious census for 1906 published in 1909. Using these two sources, the number of local Christian church organizations of all forms in the United States is seen to have grown during 1906-20 from 208,678 to 234,370; the number of ministers and priests from 164,830 to 186,018; the membership from 3,447,741 to 44,322,215; the number of Sunday schools from 189,291 to 199,274; the Sunday-school enrolment from 16,258,683 to 20,892,327.

For Roman Catholic churches the increase during the same period was as follows, the figures for 1906 being taken from the U.S. census and those for 1920 from the *Official Catholic Directory*:—

	Church Organizations	Cardinals	Priests	R. C. Pop.
1906	12,482	1	15,177	14,210,755
1920	16,580	3	21,643	17,885,646

The growth of Protestant churches, as given by the census and the *Year Book* already cited, has been as follows:—

	Church Organizations	Ministers	Members	Sunday Schools	Sunday-school Enrolment
1906	194,980	146,437	20,201,885	164,577	13,002,221
1920	215,698	163,951	26,098,513	183,991	19,004,638

In comparing these figures with those already given for the Roman Catholic Church, it should be noted that the Roman Catholic figures include as members all baptized persons, whether confirmed or not. The Protestant practice is to include in a count of members only those who were communicant members when the enumeration was made. The estimated Protestant population, counting all members of any family in which anyone is a communicant member of a Protestant church, grew from 30,000,000 in 1906 to 40,000,000 in 1920, an increase of 33.3%. The increase of Roman Catholic population during the same period, as above shown, was 26%. An exact comparison between the growth of population and the growth of church membership is impossible owing to the fact that the population census and the religious census are not taken the same year but several years apart. A comparison of figures, however, indicates that the population of the continental United States increased between 1910 and 1920 at an average annual rate of 1.5%. During the period from 1916 to 1920, on the other hand, church membership increased at an average annual rate of 2.5%.

*The World War.*—Perhaps the most striking phase of the work of the churches during the decade 1910-20 was their service in the World War. As soon as the United States entered the war almost every church or denomination organized a war commission or council to aid the Government in securing chaplains and in similar tasks. The war-work commissions of the Protestant churches cooperated in the General War-Time Commission of the Churches; while the activities of the Roman Catholic Church were carried on through the National Catholic War Council. The General War-Time Commission, besides largely developing the spirit of cooperation, was able to undertake activities which were impossible to the separate church bodies, such as surveying the needs and opportunities for religious work in the camps and war communities; coordinating the plans and efforts of the denominational commissions; representing the Protestant churches in relations with the war and navy departments; securing qualified chaplains; providing for the moral and religious welfare of negro troops; supplying religious ministrations for interned aliens; arranging for the welfare of workers in communities engaged in the manufacture of munitions and in shipbuilding; and stimulating the churches to cooperate with the Government and welfare agencies in the various campaigns for funds, food conservation, personal service, etc. Equally important work was done by the National Catholic War Council. Of the effect of the war on the American churches very little can be said. Expectations that the men would bring back from their experiences in the army or navy fresh interpretations of Christianity, and that the churches would apply in their local work many of the methods found effective among soldiers, have not been realized. Positive results, however, are: gain in practical cooperation among the churches, a larger place for the Church in the life of the community, stimulation and enlargement of missionary work and greater attention to education.

*Cooperation and Union.*—The decade 1910-20 was noteworthy among the Protestant churches for the development of cooperation and union. This appears in three fields: (1) local cooperation and federation, (2) cooperation of administrative bodies, (3) denominational federation and union. In the first of these, cooperation in local communities, there is to be noted a growing movement in the formation of federated churches, i.e. two or more churches joining their activities under the same pastor while each retains its separate organization and denominational affiliation. Several hundred of these federated churches have been organized, the Home Missions Council having (1921) a list of about 200. In many localities the growth of a community consciousness has expressed itself in one denominational church, serving the whole community, often having an associate membership for Christians of other denominational preferences, and carrying on a variety of activities for the uplift of the community. A notable development has been the exchange of territory between denominations in some

of the older states, like Vermont, and the allocation of territory to home mission agencies of different denominations in newer sections, such as Montana, Alaska and Porto Rico. In larger cities federations or councils of churches have steadily grown in number and importance. Under the leadership of the Commission on Councils of Churches of the Federal Council of the Churches of Christ in America, first organized in 1912, such federations have been formed in nearly 50 cities, having strong local financial backing and employing one or more secretaries. Among their activities are social service, evangelism, religious education, religious publicity and missions. Important conferences on interchurch work were held in Pittsburg in 1917 and in Cleveland in 1920.

In the second field of cooperation, that of denominational administrative boards, the development has been principally in missions and education, culminating in the Interchurch World Movement. The World Missionary Conference held in Edinburgh in 1910 powerfully stimulated cooperation among foreign mission boards, and the Continuation Committee has represented the American boards in organizing cooperative work in foreign mission fields. The similar Congress on Christian Work in Latin America, held at Panama in 1916, was the outcome of a conference in 1914 of missionaries and Protestant mission boards working in Mexico. Among its results is the permanent Committee on Cooperation in Latin America, which unites in many forms of service most of the boards having work there. The Foreign Missions Conference of North America, organized in 1893, which officially represents the Protestant foreign mission boards of the United States and Canada, has during the decade 1910-20 greatly enlarged its sphere of activities, particularly through its Committee of Reference and Counsel, its Board of Missionary Preparation, and its Committee on Religious Needs in Anglo-American Communities. In home missions cooperation has been greatly furthered through the Home Missions Council, organized in 1908, which aims to prevent duplication of effort and to provide for adequate occupation of fields and in general to coordinate the home mission agencies of the denominations it represents. Similar cooperation has developed among women's mission boards, through the Council of Women for Home Missions (1908) and the Federation of Women's Boards of Foreign Missions of North America (1916). The decade 1910-20 stands out beyond all previous decades in missionary cooperation, so that by 1921, with but few exceptions, the leading Protestant missionary boards were thoroughly committed to this policy. The same was true, in scarcely less measure, of the educational boards. In 1921 these united in the Council of Church Boards of Education, which collated information, studied the standardization of courses in church schools and colleges, and held conferences of university pastors and other church workers in the larger institutions. The Sunday-school agencies of the denominations formed in 1911 the Sunday School Council of Evangelical Denominations, for cooperation in educational, editorial, missionary and publishing activities.

The Interchurch World Movement of North America was organized by representatives of Protestant mission boards in 1918, primarily to meet the urgent need of expansion in missionary work as a result of the war. It rapidly extended its scope, however, to include surveys of all Christian work at home and abroad, missionary education, recruiting for the ministry and mission service, and a simultaneous appeal for funds by all cooperative church bodies. The movement failed, owing, among other things, to unbusinesslike financial operations and irresponsible activity on the part of some of its leaders; but it revealed a widespread spirit of cooperation.

In the third field of cooperation and union, that of the denominations and church bodies as ecclesiastical organizations, the development has proceeded along two lines: federation and organic union. The first is represented especially by the Federal Council of the Churches of Christ in America, organized in 1908, in which about 30 Protestant denominations are officially represented. While retaining their autonomy the

uniting church bodies have provided representative organization which operates through various commissions, including those on the Church and social service, evangelism, councils of churches, the Church and country life, temperance, Christian education, relations with the Orient, international justice and goodwill, and relations with France and Belgium. A staff of secretaries at New York and Washington care for these activities.

Side by side with federation has developed a movement in the direction of organic union. In several denominations union has taken place, as between Baptists and Free Baptists, and among various Lutheran churches. There has been approach, also, between unrelated communions, as Congregationalists and the Protestant Episcopal Church. The year 1910 was notable: on the same day there was organized, by the Protestant Episcopal General Convention, the Commission on a World Conference on Faith and Order, and, by the Disciples of Christ, the Association for the Promotion of Christian Unity, while earlier in the same year the Christian Unity Foundation had been formed. Over 70 commissions have been appointed by various church bodies to cooperate in plans for the conference on faith and order. The proposal contemplated an organic union of all the churches, Protestant, Roman Catholic and Eastern Orthodox, on the basis of an agreement concerning essential doctrines. The Roman Catholic Church, however, declined to participate. Some important Protestant churches, also, look with little interest on the conference.

The tendency in the movement towards church unity has been toward, not a complete amalgamation of denominations, but a federal union which would allow for diversity of temperament, practice and doctrine. Such was the purpose of the Council of Organic Union held in 1918, attended by representatives of 19 Protestant denominations. An *ad interim* committee was appointed which presented a plan of union at a second conference, in 1920, to become effective when adopted by six denominations.

**Social Service.**—The widening interest in social questions was a notable development of the decade 1910–20. This showed itself, first, in the recognition of social service in the programmes of the various national church bodies, and, later, in its growing recognition by local churches. During the first half of the decade most of the larger Protestant denominations adopted in their national gatherings a definite social service programme, nearly the same as the “Social Creed of the Churches” put forth by the Federal Council of the Churches. A similar statement was published by the social service commission of the American Federation of Catholic Societies. Social service commissions or departments were organized by most of the larger denominations, many having executive secretaries in charge. The commission on the church and social service of the Federal Council has been one of the most active commissions of that body since its formation, and more recently the National Catholic Welfare Council has put in operation a vigorous social programme. One result of this development of social interest is seen in the place given in the theological seminaries to social service and training for community leadership. Quite as significant is the addition of these subjects to Sunday-school study courses. So far as the official organizations of the denominations are concerned, social service has become definitely established as a vital part of their programme.

Naturally the progress in the local churches has been slower, but it may be said in general that the churches have come to recognize their social responsibility, though in their working programmes they differ widely. While the movement of churches from the business sections of large cities toward the residential sections and suburbs still persists among Protestant churches, a tendency in the opposite direction has also developed, and well-organized churches are being established in the heart of large cities. In some cases several denominations have cooperated in apportioning the field. In Cleveland, for example, 30 such churches are planned, of which 10 are already in operation, different sections being cared for by different

denominations. A similar and allied movement is the establishing of Christian centres or community houses. These are under church direction, are staffed by trained workers and undertake various activities: kindergartens, day nurseries, mothers' meetings, industrial classes, forums, boys' and girls' clubs, employment bureaus, rescue work, lectures, music classes, gymnastics, etc., besides Bible study and religious worship. In rural communities progress has been slower, but in many of the Protestant denominations larger attention has been given to the cultivation in the country churches of the ideal of thorough-going community service—religious, social, educational, economic. Both nationally and locally the churches, city and country alike, have exercised a powerful influence in favour of prohibition, and the adoption of the Eighteenth Amendment is due principally to their efforts.

In the field of industry, the social service pronouncements of the churches have been outspoken in favour of better conditions and opportunities for labour. Efforts have also been made to cultivate closer relations with the unions, as by sending fraternal delegates or appointing special representatives. The Federal Council of the Churches each year issued a Labour Sunday message for the first Sunday in Sept. and many churches observe the day.

**Missions.**—The American churches in their mission work have progressed in cooperation, organization and expansion. The decade opened with the holding of the World Missionary Conference at Edinburgh, in which American Protestant mission boards played a large part. As a result of this conference and the Congress on Christian Work in Latin America, held at Panama in 1916, and of the continuation conferences that followed in many mission fields, the boards have largely broadened their field of cooperative activities, particularly in educational and medical work. Other important factors aiding in this development have been the Foreign Missions Conference of North America, the Federation of Women's Boards of Foreign Missions, the Home Missions Council and the Council of Women for Home Missions, which represent most of the mission boards of the Protestant churches. The Edinburgh Missionary Conference resulted in increased efficiency of organization and greater interest in missions. In several church bodies missionary agencies have been combined and missionary administration centralized; steps have also been taken toward uniting the missionary agencies of different denominations. Increased attention has been given to missionary education, through study groups, women's societies, Sunday-school classes, and reading contests. Interdenominational summer conferences and schools for development of missionary leaders have grown rapidly in number and quality of work. A very important movement has taken place in the securing of new missionaries. Some denominations have appointed candidate secretaries for their mission boards, and interdenominational conferences have been held to consider the problem. The most significant development in this connexion was the organization in 1911 of the Board of Missionary Preparation, which made a thorough study of the best methods of preparing for work among peoples of different lands and different religions.

The rapid expansion of mission work by the American churches during the decade will be evident from a few figures. For home missions the Protestant churches appropriated in 1912 (the first year for which figures were compiled) \$10,653,119; in 1920, \$23,435,601. The number of home missionaries fully supported by the church boards in 1916 was 3,372; in 1920, 4,473. Foreign mission income grew even more rapidly, the figure for 1910 being \$11,946,281 (including both the United States and Canada); in 1920, \$10,292,602. The number of foreign missionaries sent out was as follows (United States and Canada):—

1910	617	1916	772
1911	818	1917	661
1912	812	1918	641
1913	620	1919	1,137
1914	531	1920	1,686
1915	609		

In 1910 the Roman Catholic Church had 20 American foreign missionaries; in 1920, 50. The first American Roman Catholic foreign mission seminary was founded during the decade, and several religious orders of this Church were engaged in preparing men and women for the foreign mission field.

While new enterprises have been undertaken the policy has been primarily to strengthen existing work. Expansion has taken place especially in union schools, colleges, hospitals and other institutions. Many denominations have frankly faced their whole task in those parts of the world which might be considered as their responsibility, and after careful survey of the needs and requirements they have undertaken financial campaigns covering home and foreign missions and education. The total number of these forward movements was



26, the total objective being nearly \$400,000,000. In most cases, for various reasons, the completion of the financial campaigns was delayed, but large sums were secured by all the denominations and the work was correspondingly strengthened.

In continuing the attention of the churches to evangelism (in the larger sense of enlisting individuals in the programme of Christianity) a variety of methods has been employed. The earlier years of the decade saw the development of spectacular mass meetings led by a professional evangelist, this method reaching its culmination just before the war. In the latter part of the decade, however, more attention has been given to the work of the pastors themselves. City-wide campaigns, in which all or most of the churches cooperate, with services conducted by them separately but accord-

ing to a uniform plan, became common. Many denominations have departments and secretaries of evangelism, who cooperate with the Commission on Evangelism of the Federal Council in developing interest and organizing the work.

**Education.**—Religious education advanced conspicuously during the decade. In 1910 the Sunday-School Council of Evangelical Denominations was formed, representing the official Sunday-school agencies of the Protestant churches; in 1912 the World's Sunday-School Association added to its executive committee the official representatives of the church boards; in 1914 the International Sunday-School Lessons-Committee took similar action; and in 1920 plans were made to amalgamate the International Sunday-School Association and the Sunday-School Council. The significance of

STATISTICS OF CHRISTIAN CHURCHES IN THE UNITED STATES—1920  
As given by Year Book of the Churches for 1920.

Name.	Church Congregations.	Ministers.	Members.	Sunday Schools	Sunday-school Members.	Total Expenditures.
Adventists	2,772	1,526	123,143	3,177	113,629	\$ 2,505,786
Apostolic Christian Church	52	73	5,000	40	3,315	29,893
Apostolic Faith Movement	24	26	2,196	26	769	38,380
Assemblies of God	1,000	537	6,793	81	4,839	61,941
Baptists	61,992	46,086	7,598,280	48,750	4,305,170	44,460,716
Brethren	1,262	3,767	122,932	1,304	119,706	917,461
Catholic Apostolic Chs.	13	13	2,768	4	192	29,740
Christadelphians	145	13	2,922	79	3,101	16,340
Christ. and Miss. Alliance	166	114	9,625	161	11,077	232,029
Chris. Ch., Amer. Chris. Con- vention	1,204	1,037	105,310	963	76,055	644,044
Chris. Congregation	15	28	3,000	15	1,650	20,000
Chris. Union	220	211	13,692	173	13,061	47,079
Ch. of Christ, Scientist	1,589	..	..	..	..	..
Church of God	429	490	12,012	232	7,796	5,931
Ch. of God and Saints of Christ	94	101	3,311	57	1,783	18,674
Ch. of Nazarene	999	844	35,041	990	50,397	239,986
Churches of Christ	5,570	2,507	317,937	3,441	183,022	679,091
Churches of God in N.A., Gen- eral Eldership	458	419	25,847	413	37,952	37,828
Church of the Living God	184	450	14,050	88	1,925	20,012
Church of the New Jerusalem	116	134	7,252	81	4,488	189,129
Congregationalists	6,019	5,722	808,122	5,804	709,859	11,608,650
Disciples of Christ	8,912	6,031	1,193,423	8,643	961,723	10,413,823
Eastern Orthodox Churches	393	368	303,844	169	10,019	886,857
Evangelical Association	1,729	1,327	159,310	1,700	222,793	7,506,769
Evang. Prot. Ch. of N.A.	37	34	17,962	38	8,792	197,194
Evang. Synod of N.A.	1,385	1,131	352,644	1,301	141,015	1,443,272
Free Chris. Zion Ch. of Christ	35	29	6,225	35	3,699	19,154
Friends	861	699	107,422	754	56,615	825,337
Internat'l Holiness Ch.	325	640	11,000	152	8,975	73,639
Lithuanian Nat. Cath. Ch.	7	3	7,343	1	142	17,374
Lutherans	15,638	9,731	2,451,997	7,429	955,336	24,587,539
Mennonites	887	1,488	82,722	706	42,236	456,193
Methodists	67,493	46,364	7,867,863	69,078	7,287,381	69,114,296
Missionary Ch. Association	25	59	1,554	29	3,343	37,939
Moravians	136	183	28,402	135	17,435	317,879
Non-Sectarian Chs. of Bible Faith	58	26	2,273	12	571	1,263
Old Catholic Churches	9	19	34,025	6	840	21,700
Pentecostal Holiness Ch.	192	282	5,353	143	8,143	50,600
Plymouth Brethren	470	..	13,717	261	12,813	185,954
Polish National Cath. Ch.	34	45	28,245	27	2,967	149,839
Presbyterians	16,666	14,623	2,243,678	14,627	1,847,945	36,536,465
Protestant Episcopal Ch.	8,103	5,677	1,065,825	5,790	435,761	22,509,942
Reformed Episcopal Ch.	65	65	11,806	60	7,750	132,079
Reformed	2,779	2,236	535,040	2,758	484,548	7,042,538
River Brethren	112	248	5,389	71	6,180	34,752
Roman Catholic Ch.	16,580 <sup>1</sup>	21,643 <sup>1</sup>	17,885,646 <sup>1</sup>	12,800	1,932,206	72,358,136
Salvation Army	957	2,918	28,586	720	46,823	1,722,120
Scandinavian Free Ch.	458	506	37,816	453	47,347	722,535
Schwenkfelders	6	6	1,190	6	1,961	7,889
Unitarians	4	808	82,515	346	2,160	1,485,550
United Brethren	3,907	2,810	367,087	3,599	478,119	4,716,157
United Evangelical Chs.	949	535	88,817	955	121,391	729,045
Universalist Chs.	650	361	58,566	467	58,442	1,060,075
Volunteers of America	97	307	10,204	26	1,611	232,010
Fourteen churches having less than 1,000 members	177	434	5,593	108	4,459	222,258
Totals for 68 denominations	234,330	186,018	44,322,215	199,274	20,892,327	\$327,615,335

<sup>1</sup> As given by *Official Catholic Directory*.

<sup>2</sup> The Roman Catholic Church includes in its membership, as already stated, all who have been baptized—that is, practically all the members of Roman Catholic families. Protestant churches, on the other hand, reckon as members communicants only, with the exception of a few denominations, e.g. Lutherans, who publish figures for both communicant members and baptized members. The statistics given for Protestants in this table, as elsewhere in this article, are for communicant members only.

these changes lies in the growing recognition of pedagogical principles in the church schools. Schools having graded departments and a graded curriculum have increased in number, and the higher standard of work has resulted in the creation and use of an increasing body of technical material for teachers and executives. The importance of a trained teaching force is gaining larger recognition; standard normal courses have been improved; summer schools of methods have grown in number and attendance; and community schools of religious education, meeting on a week-night for an extended period, with classes studying the Bible, pedagogy and departmental methods, having sprung up rapidly in many parts of the country. This new interest in religious education has led to important developments. A new religious profession is growing up, that of director of religious education in a local church. Colleges and theological seminaries have established courses in religious education, and several have organized departments or schools for the study of this and allied subjects. Especially noteworthy is the providing of rooms for school uses in Protestant churches as a result of the increased attention to the educational side of the work. This change began before the decade under review, but has now become practically universal in its influence. Finally, it is being recognized that the ordinary Sunday-school session does not give sufficient time for proper religious instructions, and various methods of week-day instructions have been adopted, by churches separately, or by groups of churches, or in cooperation with the public schools.

There is a growing feeling of responsibility for their educational work on the part of the churches. Boards of education have been organized by some denominations and these of others have been strengthened; most of the movements have included in their financial objectives large sums for education; and the relations between the churches and the schools and colleges, both denominational and undenominational, have been made correspondingly closer. This interest has grown since the war. The Knights of Columbus, for example, set aside a very large sum for educating worthy men, regardless of their church relations, and Protestant churches have correspondingly enlarged their programme. Roman Catholic institutions have also conducted financial campaigns and largely increased their funds. Most of the money has been raised for the equipment or endowment of institutions related legally or by tradition to the various churches, with a resulting increase in facilities and strengthening of teaching force. In most of the denominational schools and colleges the Bible has a prominent place in the curriculum, the number of chairs of Biblical literature or religious education having increased to about 200. An important development of the decade has been the installation of university pastors by various denominations in connexion with the larger institutions, to care for their own students, to keep them in touch with the church, to give friendly counsel in their problems, to organize Bible classes, etc. In smaller institutions several denominations combine in the support of one representative. There were 320 of these workers in 1920 giving whole or part time to the work. A student church has been organized in a few centres, and some denominations have undertaken the establishment of a school of religious education in connexion with a university. All these church representatives work in close relation with the student Christian associations. Student conferences, directed by the Y.M.C.A. and Y.W.C.A. or by the denominational education boards, have grown in importance. Co-operation with these two organizations and with one another through the Council of Church Boards of Education (organized 1911) has been a growing feature of the educational work of the churches during the decade.

In the development of thought religious experience has become increasingly the test of doctrine, and interest has shifted from dogma to life. Religion is thought of in terms of this life, not primarily with reference to the next, considered not as belonging to one part of man's life but as affecting the whole range of human experience.

There was notable growth during the decade in (1) laymen's activities, especially in the Laymen's Missionary Movement, the Men and Religion Movement and the Y.M.C.A.; (2) religious publicity, manifested in the combination and strengthening of church papers and the increasing use of secular newspapers and magazines for advertising and descriptive articles; and (3) international relations, in which there has been a widening of interest and an enlarging of activity through denominational and inter-denominational organizations. (S. R. W.)

**CILICIA** (see 6.365).—During 1909-21 the old geographical name of Cilicia came again into familiar use, chiefly in connexion with Armenian matters. The ancient district of Cilicia covered nearly the same territory as the medieval kingdom of Lesser Armenia, and the present population includes a considerable Armenian element. This portion of south-eastern Asia Minor, therefore, is regarded by Armenians as a region which should form part of an independent Armenia, or itself become an independent protected Armenian state until the greater project can be realized. Unhappy events in recent Armenian history have been enacted in Cilicia, largely owing to Armenian aspirations; thus convenient usage has linked the ancient name with the fortunes

and tragedy of the Armenian race. Cilicia of present Armenian interest includes the Turkish vilayet of Adana, the independent sanjak of Mar 'ash, and the sanjak of 'Aintab in the vilayet of Aleppo. In these areas there were, in 1914, about 175,000 Armenians, while the population included some 500,000 Moslem and other elements.

The recent history of Cilicia belongs, in the main, to the history of the Armenian people (see ARMENIA). In 1909 the Adana massacres—destructive of hopes created by the Turkish Revolution of 1908—extended over the whole of Cilicia. During 1915-6 massacres and deportations organized by the Young Turk Government destroyed or removed the greater part of the Armenian population—including the 20,000 inhabitants of Zeitun, an Armenian mountain stronghold, never hitherto entirely subdued. In 1918-9 Cilicia was occupied by British troops after their conquest of Syria, but on being evacuated by them passed under French control. Subsequently the Treaty of Sèvres assigned to France the southern portion of Cilicia, as far westward as the left bank of the river Jihan, as part of the mandated territory of Syria. The remainder of Cilicia was brought within the French sphere of influence in Asia Minor by the Tripartite Agreement, executed at the same time as the Treaty of Sèvres.

Under French occupation Cilicia received a large immigration of Armenians owing to their reliance on French protection and the hope—apparently without much foundation—that a Franco-Armenian state would be created. The province was the scene of continued warfare between French troops and Turkish Nationalists during 1920, in the course of which the Nationalists gained several successes, and were able to renew the massacre of Armenians on a large scale. In the spring of 1921 an agreement was signed on behalf of the French and Nationalist Governments whereby France was to evacuate Cilicia, and the southern frontier of Turkey, as defined in the Treaty of Sèvres, was to be removed southward about 40 miles, for the whole distance from the Gulf of Alexandretta to the frontier of Mesopotamia. These proposed territorial concessions by France the Great National Assembly at Angora considered inadequate, and in consequence it refused to ratify the agreement; and in September 1921 France, therefore, still remained in occupation of Cilicia. (W. J. C. \*)

**CINCINNATI** (see 6.370).—During the decade 1910-20 the area of Cincinnati was extended from 44 to 72 sq. miles. The pop. in 1920 was 402,247, as compared with 363,591 in 1910, an increase of 37,656, or 10.4%. In 1920 the city possessed parks covering 2,691 ac., including the Mt. Airy Forestry project which embraces 1,132 ac.; and a plan was being carried out for further extension by utilizing the boulevards and bluffs. The widely discussed statue of Lincoln, by George Grey Barnard, presented to the city by Mr. and Mrs. Charles P. Taft, was unveiled in Lytle Park in 1916. The city was building in 1921 a rapid transit loop at an initial cost of \$6,000,000, which with subway, surface and elevated railways will encircle the city, provide access to inter-urban traffic and relieve congestion. The traction roads were being operated under a service-at-cost contract.

**Manufactures.**—In 1919 there were more than 2,300 manufacturing establishments in Cincinnati proper, covering 90 industries, with capital of \$265,000,000 and products valued at \$600,000,000, employing 112,000 persons of whom one-fourth were females. The five most important industries in the Cincinnati district were soap and soap products, \$100,000,000; foundry and machine-shop products, \$50,000,000; slaughtering and meat packing, \$45,000,000; clothing (men and women), \$35,000,000; printing and publishing, \$30,000,000. In 1916 the freight movement by boat was 1,411,149 tons, of which 1,252,739 were receipts. The chief cargoes were coal, stone and sand, lumber and grain.

**Government.**—A new charter was adopted on Nov. 6 1917 providing that the city "shall have all the powers of a local self-government and all other powers possible for a city to have" under the state constitution. The mayor and council were to be elected for a term of four years, the chief executive offices to be filled by appointment of the mayor. The charter provided for a city planning commission of seven members, consisting of the mayor, the director of public service, the three park commissioners and two citizens. It was to submit recommendations for new streets, subways, bridges, playgrounds and parks. In 1919 an ordinance was enacted forbidding the erection or maintenance of billboards within any residential block without the written consent of the

owners of the majority of property on both sides of the street. In 1920 the city's aggregate receipts, including balances on hand, were \$24,346,445 and disbursements \$17,330,791 leaving a cash balance, practically covered by authorizations, of \$7,015,654. The tax valuation for that year was \$737,472,310. The rate of taxation was \$20.02 per thousand. The municipally owned waterworks and the Southern Railway, also municipally owned, were more than self-supporting. As a result the net debt not self-supporting on Dec. 31 1920 was \$37,887,582.

**Education and Charities.**—In the decade 1910-20 extensive additions were made to the Jewish, Good Samaritan, Bethesda, and Christ hospitals, and to the tuberculosis sanatorium. The General hospital with its group of 24 buildings, occupying 27 ac. and considered the best example of the pavilion type on the continent, was finished in 1915 at a cost of \$3,500,000. Its capacity in 1920 was 850 beds. It is under the administration of the university of Cincinnati, whose new medical school adjoins it. Other new buildings and departments of the university (3,565 students in 1920) included the law school, the college of engineering and commerce, the college for teachers, the training school for nurses, the school of household arts, a department of hygiene and physical education, a new gymnasium and athletic field, evening departments, and a woman's building. The cooperative system, originated in Cincinnati, of supplementing college instruction by practical training in various shops and manufacturing establishments, was greatly expanded between 1910 and 1920. Several new high-school buildings were erected, with improved class-rooms, laboratory, and gymnasium facilities which served to complete an educational system which carried the student at public expense from the kindergarten through the graduate schools of the municipal university. The public school expenditures for 1920 were \$4,749,605. The enrolment of the day schools was 51,104 and night schools, 14,864, with 1,623 teachers in 70 school buildings, including 3 high schools. The Roman Catholic university of St. Francis Xavier in 1919 removed its college department to a 26 ac. tract in the suburbs adjoining the newly developed boulevard system of the city and constructed administration, science and recitation buildings. The colleges of music increased in buildings and faculties; and in 1915 the Cincinnati Symphony Orchestra received an endowment of \$1,000,000 as a bequest from Cora M. Dow. Of special importance was the recent establishment of the American House for the training of aliens for citizenship, and for social service work.

**Building.**—Between 1900 and 1919 nearly \$100,000,000 was spent in new buildings, among which were the Union Central Life of 34 stories, 495 ft. high, the tallest building west of New York City; a court house, in modern Ionic style, completed in 1919 at a cost of \$5,000,000; and the Dixie Terminal for the Kentucky traction lines.

**World War.**—During the World War Cincinnati supplied 1,200 men to the Marine Corps; 1,400 to the navy, and 15,000 to the army. To the Liberty and Victory Loans Cincinnati subscribed \$212,946,300. (C. T. G.)

**CINEMATOGRAPH OR MOTION-PICTURES** (see 6,374).—The word "cinematograph," frequently shortened to "cinema," designates primarily the mechanism by which motion-pictures are projected on to the screen, but the term has come to be used generically to refer not only to the entertainment but to various phases of its production. In the United States, the designation "motion-picture" or "moving-picture" (colloquially, "the movies") is much more frequently used, though "photoplay," referring specifically to dramatic compositions, is commonly employed.

In 1920 the cinematograph as a means of entertainment was making its first bid for public favour; it was still a novelty, and many persons, including experienced showmen, thought its appeal would decline as soon as the novelty had been thoroughly exploited. Before 1920, however, it had become by far the most popular form of commercialized amusement throughout the world. The production of motion-pictures on a large scale was in 1920 confined to a few countries, chiefly the United States, Great Britain, Italy, Germany, and France, but their exploitation was world-wide. Their appeal was apparently limited by no ordinary conditions of age, race, or degree of civilization, and it was asserted, a little grandiloquently perhaps, that they constituted the one universal language. In 1920 it was estimated there were throughout the world at least 40,000 cinema theatres, of which perhaps 17,000 were in the United States, 5,000 in the British Isles, 3,000 in Germany, 2,700 in France, 5,000 or more in Italy, 1,200 in Spain, 800 in Australasia, 700 in Sweden, 600 in Japan, and so on. There was hardly a country too remote not to have at least a few motion-picture theatres, and occidental films had penetrated where occidental ideas were still regarded with

prejudice and disfavour. Constantinople, for example, had 11 cinema theatres, Canton 10, Bangkok 9, Rangoon 8, and Tientsin 6. Such theatres, of course, exhibit American, English or European films almost exclusively. It is perhaps interesting to note that in Constantinople only religious pictures were subject to censorship. In South America the cinema was as popular as elsewhere; Buenos Aires, for example, had 131 theatres, and nearly every Argentine town of more than 1,000 population had its moving-picture palace. In the United States the daily attendance at motion-pictures in 1920 was estimated at a little less than 10,000,000, while a British estimate in 1919-20 was that a number equal to half the population of the British Isles attended the cinematograph twice a week—which would be equivalent to a daily attendance of more than 6,000,000. If this estimate is correct it indicates that the cinema attendance in the United Kingdom practically doubled after 1916-7, when a careful estimate placed the daily attendance at 3,375,000 (see *The Cinema*, 1917). The same report gave the following analysis of seats occupied in the course of a year (week-days):—

Price of seat	No. occupied	Per cent of total
1d. . . . .	78,250,000	7.4
2d. . . . .	58,844,000	5.6
3d. . . . .	400,640,000	38.0
4d. . . . .	186,235,000	17.6
6d. . . . .	195,468,500	18.5
9d. . . . .	97,812,500	9.2
1s. . . . .	39,125,000	3.7
<b>Total</b>	<b>1,056,375,000</b>	<b>100.0</b>

(This tabulation is based on an estimate of 4,500 theatres with an average daily attendance per theatre of 750. In 1917 the price of seats had begun to go above 1s.; in 1920 in London it was frequently 2s., 3s., and higher in the best houses.)

From the business point of view remarkable progress was made during the decade 1910-20. In the United States, where the industry had reached its highest commercial development, the gross receipts of all exhibitors in 1920 were placed at \$800,000,000 (as against \$675,000,000 in 1918 and \$65,000,000 in 1907). The price of admission was usually from 25 to 50 cents; in small towns or poorer neighbourhoods it was sometimes less, while the best houses in New York frequently charged from \$1 to \$2.50.

U.S. Government statistics show that the total gross income of American motion-picture producers (manufacturers) was about \$90,000,000 annually. Capital invested in the producing business was estimated at \$100,000,000, while the amount of positive film "consumed" each week was said to be 10,000,000 ft., as compared with 3,000,000 ft. before the World War. The following table shows the operations of one of the leading American film companies (Famous Players-Lasky):—

	1919	1918
Gross income . . . . .	\$27,165,327	\$18,000,500
Cost of film production . . . . .	16,815,836	12,647,320
Cost of selling and distribution . . . . .	5,822,860	3,904,918
Other expenses . . . . .	1,393,846	257,087
Operating profit . . . . .	3,132,985	1,281,175

The outbreak of the World War favoured the growth of the industry in the United States to such an extent that it became by far the leading producing country in the world. In most European countries, as well as elsewhere, the majority of films displayed after 1915 were of American origin. About 75% of the films shown in Great Britain in 1920 were of American manufacture. The extent of American exports in that year is indicated by the following table:—

U.S. Exports of Exposed Films.

	Linear Ft.	Value
United Kingdom . . . . .	45,538,551	\$2,348,256
France . . . . .	22,250,847	943,781
Canada . . . . .	17,952,511	1,226,514
Australia . . . . .	14,238,587	653,047
Argentina . . . . .	9,900,491	330,104
Brazil . . . . .	8,416,158	363,544
Cuba . . . . .	6,761,701	248,226
Japan . . . . .	6,302,468	233,028
Spain . . . . .	6,071,560	242,569
Denmark . . . . .	5,816,537	233,646
Norway . . . . .	3,410,232	330,770
Newfoundland and Labrador . . . . .	1,950,337	79,541
Italy . . . . .	677,120	30,273
Other countries . . . . .	39,220,065	1,625,526
<b>Total</b>	<b>188,527,165</b>	<b>\$8,888,535</b>

European production, however, was beginning to regain lost ground; artistically the best European work was not infrequently superior to that produced in America. Germany's recovery seemed particularly rapid; this was due in part to legislation prohibiting the importation of foreign films until May 1920, and even after that date the introduction of foreign films was to be strictly limited. In England producers were making great efforts to meet American competition, though, without the aid of legislation. The manufacture of motion-pictures in Great Britain, however, suffered from the handicap of a climate which, being often dull and lacking in sunlight, was not well adapted to photography. This handicap was partly overcome by improved methods of artificial lighting. Gross receipts from all cinema theatres in the British Isles were estimated in 1920 to be about £35,000,000 annually. Data for other countries were lacking; in France, however, the official statistics for Paris show that in 1919 the receipts of cinema-theatres in that city were 49,664,661 francs as compared with 26,388,292 francs in 1918 and 17,377,000 francs in 1917. Admission prices ranged from 1.50 francs to 2.50 francs.

In 1919-20 some of the larger American companies sought and obtained financial assistance from leading banking houses, which had hitherto held aloof from the industry. As a condition of this assistance the banking interests indicated they would insist upon greater attention to economy and conservative business practice than had characterized the industry in the past. The sudden prosperity of the film producers had naturally led to lavish expenditures; this is well illustrated by the amount of the salaries paid to motion-picture actors and actresses. Towards the close of the period 1910-20 capable actors of the legitimate stage were able to obtain from \$100 to \$1,000, and in relatively few cases as high as \$1,000 a week; cinema salaries, however, were in most cases at least twice as large, while favourite "stars" were frequently able to command a weekly salary ranging from \$5,000 to \$10,000. Even these figures were surpassed in the case of a few of the best-known popular favourites; the combined annual income of three leading stars, for example, was said to be \$1,500,000 (1920). After 1920 the influence of conservative investors was beginning to make itself felt, and there was a tendency to reduce salaries and to introduce other economies. It was seen that this new influence would make for greater stability in the industry and probably for better pictures.

**Mechanical Progress.**—The popularity of the moving-picture led to much research to determine its inventor, and the difficulties were not altogether removed by the assertion of Thomas A. Edison (see his letter to the *New York Times*, June 9 1921) that the honour belonged to him. It is true that the modern cinematograph was evolved out of Mr. Edison's kinesiograph, or kinetograph, though these devices likewise owed a great deal to earlier experiments. But the prototypes of the modern projecting machine seem to have been produced by others—apparently by three men: Louis Lumière in Paris, R. W. Paul in London and C. F. Jenkins in Washington, D.C., each of whom was engaged virtually at the same time (1894-5) on the new invention. Their efforts all contributed to the final result, and the cinematograph of 1920 had not changed greatly from what it was 25 years before, when, relying on the well-known psychological principle of persistence of vision, it was first made a practical device for reproducing "animated pictures" on the screen. In matters of detail, however, great improvement had been made.

An important advance was the adoption of a standard film, 1½ in. in width, with 16 pictures, sometimes called "frames," each 1 by 1½ in., to every foot of film. Near the margins of the film, on either side of the pictures, are sprocket holes by means of which the strip of miniature photographs is run through the projector at the rate of approximately one ft. a second, about the lowest practicable speed to give a satisfactory illusion of motion. On the reels used in the projectors about 1,000 ft. of film could be wound; the term "reel" thus came into use as a unit of measure. The elimination of "flicker," which caused much annoyance in early cinematograph exhibitions, was brought about partly by improving the mechanism which draws each succeeding picture momentarily into place and partly by increasing the number of revolving shutter blades from one to three, of which one serves to cut off the light while the change of picture is effected and the other two merely increase the frequency of the alternations of light and darkness, thus rendering them less noticeable.

Other valuable improvements were made in the nature of the screen on which the image is thrown, in the quality of the lenses, and in the electric lamp used to illuminate the film pictures. In the early days of cinematograph projection the danger arising from the inflammable nature of the celluloid film was very great. An effort to reduce this danger was made by interposing a trough of circulating water between the electric arc and the optical condenser to absorb the greater part of the heat rays. A safety shutter was also devised to cut off the light from the film when the motion of the latter was halted for any reason. Strict enforcement of regulations

requiring that machines be enclosed in fire-proof "booths" while being operated greatly reduced the danger of serious fire losses when film did become ignited. After 1913 a non-inflammable film, made of acetate of cellulose, was put on the market; unfortunately films of this material were found to be less durable than those of celluloid, and were not widely adopted.

The cinematograph camera, being in a sense merely the reverse of the projecting mechanism, was developed along similar lines; and the best models were adapted to record almost any moving scene with great fidelity. Although somewhat cumbersome they were still easily portable, making it possible to use them in remote explorations as well as in picturing current events. In commercial practice, the films, after exposure, were mounted on frames (holding from 150 to 300 ft.), developed often by means of machines, fixed and washed in large tanks, and then wound on drums, 5-10 ft. in diameter, and dried by being rapidly revolved in warm, dry air. From the resulting negative it was possible to print as many positives as might be desired. This was ordinarily accomplished by means of a printing machine in which the strip of negative, superimposed on a strip of unexposed positive film, moved past an illuminated opening with an intermittent motion, somewhat as in a projecting machine. As long as the negative is preserved it is possible to obtain fresh reproductions of the original picture.

**Colour Pictures.**—The first colour pictures were made by colouring each small picture or frame by hand. This was laborious and expensive, therefore not well adapted for wide exploitation. The most successful of the early efforts to reproduce natural colour by mechanical means was that of Charles Urban and George A. Smith of London, whose "Kinemacolor" pictures were for a time very popular; the Kinemacolor representations of the Coronation of King George V. (1911) and the Durbar at Delhi were displayed all over the world. Although never entirely satisfactory, the essential features of Kinemacolor had an important bearing on later experiments, and for that reason may be briefly noted. The pictures in this process are taken through a revolving screen or light filter which exposes alternate spaces on the sensitized film to the green and the red rays, respectively, so that each pair of frames represents all the colour values that may be derived from these two primary colours. The resulting negative is black and white. In projection a revolving filter corresponding to that employed in the camera is used, with the result that alternating green and red pictures are displayed; but because of the rapidity with which this is done the eye fails to distinguish between the two and a colour combination is effected. The process involved additional expense for the exhibitor for the reason that special equipment designed to project the pictures at twice the normal speed was required. This objection might not have proved material if the representation were free from certain obvious faults such as false colour values, arising from the use of only two primary colours, and "fringing," due to the fact that a certain time elapses between the exposure of each negative, the result being that a moving object will often occupy a slightly different position in the "red" frame, for example, from that which it occupied in the preceding "green" frame. Thus when the two frames are combined there is an imperfect "register" of colours.

Later experimenters endeavoured to overcome these difficulties by various means; in the process exhibited by Léon Gaumont in Paris in 1912 three lenses were used to produce three-colour images simultaneously; in reproduction, of course, the process was reversed. Another device, displayed at the American Museum of Natural History (New York) in 1917, elaborated the Kinemacolor process by exposing the negative through a four-colour—red-orange, blue-green, yellow and blue-violet—revolving filter; the filter used in projection, however, contained only two-colour divisions. A promising development in 1921 was the process invented by W. H. Peck of New York. This is a two-colour method, but it differs from Kinemacolor in that each pair of negatives is obtained simultaneously by means of a prism which splits the light so that part of the rays are directed to one frame and the remainder to the other. After development the "green" negative frames are printed on one side of the positive film, and the corresponding "red" frames on the other; the positive is then developed and passes through a series of vats and tanks, coming out coloured, dried and ready for exhibition through the ordinary projection machine. The production of the positive is a complicated process, and it remained to be seen whether it could be successfully employed commercially. The result nevertheless seemed to approximate the requirements of an ideal colour film, which should consist of a series of pictures, each a complete colour-rendering of the subject in itself, so that the film could be exhibited on any machine at a normal speed. Despite the progress made in colour photography the majority of films displayed in 1920-1 were still in black and white, or in some monochrome tint which could be obtained either by dyeing the film itself or by placing a colour screen in front of the projection lens. Some colour films were made by an adaptation of the hand process in which the colouring is done with the aid of stencils.

**Vocal Pictures.**—The invention of the phonograph had preceded the moving-picture by about 18 years; it was natural, therefore, that efforts should be made to synchronize the two in order to produce talking pictures. Encouraging results were obtained by Léon Gaumont in Paris as early as 1910 and two years later by Thomas A.

Edison in America. The usual method was to make the phonographic record first, the actors merely speaking their lines into the gramophone without attempting to pose before the camera. Rehearsals were then necessary to enable the actors to fit their actions to the dialogue as repeated by the record already obtained; and the only remaining problem was to ensure a synchronization in the theatre of the phonograph and the picture. This was accomplished by means of electrical devices to control the speed of the phonograph. For various reasons, most of which will be obvious to any one familiar with the phonograph, this sort of talking picture never became popular; instead of enhancing the representation, the phonograph seemed merely to emphasize its artificiality. Later in the decade other methods, seemingly more adequate to give the necessary illusion, were devised and exhibited. The later experimenters abandoned the gramophone altogether; in the scheme elaborated by Eugene Lauste of New York the sound waves are transferred, by means of microphones, to a circuit containing a sensitive string galvanometer, and the fluctuations of the string or wire of the galvanometer are recorded photographically on the side of the film. When developed one side of the film shows a series of peaks resembling the profile map of a mountain range. Reproduction is accomplished by the use of a selenium cell placed in front of the moving film; the sound waves are then conveyed electrically to the rear of the screen and disseminated through loud-speaking telephones. The cinema industry showed comparatively little interest in vocal pictures and their future was uncertain. Another problem which engaged the attention of inventors concerned the discovery of some method of obtaining stereoscopic effects on the screen. One solution of the problem failed of success because, in order to complete the illusion, every spectator was required to wear a pair of specially devised spectacles; most audiences, it was found, were not only reluctant about putting them on but took little pleasure in the result, even though the effect was superior to that of a flat picture.

*Recreational Aspects.*—Improvements in apparatus, while important, were overshadowed during the decade 1910-20 by the truly remarkable achievements in developing the artistic, educational and recreational possibilities of the cinema. It is true that in 1910 the cinema had begun to outgrow that early period when its repertory consisted largely of express trains, automobile races, military parades and like subjects. The first step had been taken, and the pictures began to be connected by a story; the express train, for example, suggested the pictorial possibilities of a train robbery, and a story was invented to give the scenes continuity and culmination. Then the story became the chief thing. But the development in the cinema of the story-telling art was hindered by the circumstances of its early exploitation. The pictures of that period were exhibited either as part of vaudeville entertainments, where they took the place of the usual feats of legerdemain, or in cheap halls that had been converted from other purposes; the latter were usually dark, ill-ventilated and far from clean. Every circumstance of their presentation tended to discourage attendance by the better classes of the community. Yet their cheapness—the admission price was usually five cents in the United States and fourpence, or less, in England—attracted thousands of people for whom no amusement of so absorbing a character had ever been provided at so small a cost. Wherever the moving picture was introduced similar conditions prevailed; the initial appeal was almost uniformly to the illiterate, the half educated, and even, as it seemed, to the mentally incompetent. Probably no art ever developed under so great a handicap; the result, still obvious in the crudity and vulgarity of later films, was too often attributed to some inherent coarseness of the medium rather than to the unhappy conditions of its origin. But it was not only the character of those early audiences which left its impress on the cinema art; it was also the character of the men who engaged in this new industry. They were for the most part showmen of the itinerant, hand-to-mouth type, promoters and managers of the cheapest forms of vaudeville entertainment. Some of them remained exhibitors only; others began to assemble companies and produce motion-pictures. While many persons of intelligence and ability had been attracted to the industry by the end of the decade, not a few of the most influential men in the business were those who had been carried to success by the sheer momentum of the new art; they were survivals of that early group of showmen whose hope of profit lay in exploiting the crudest instincts in the most obvious fashion.

Yet in estimating the social influence of the moving-picture, even in that early period, it would be a mistake to overlook the fact that in many localities the cinema afforded the only effective competition with the allurements of the saloon and public-house. However bad the pictures were, and they were usually aesthetically rather than morally reprehensible, nevertheless they were a positive benefit in comparison with many types of amusement that were open to the poorer classes. When the workman's family began to insist that he take them to the moving-picture palace of an evening he found it more difficult to offer an excuse for going to the bar. With the advent of Prohibition in the United States the motion-picture interests profited greatly; the cinema then became one of the most effective substitutes for the liquor saloon.

It is not surprising that for an appreciable interval many actors who had achieved fame on the stage refused to act for the "movies." Cultivated opinion was inclined to scorn if not to denounce the photoplay. For a time it seemed improbable that the moving-picture could ever be lifted above the vulgarity of its origins. The cinema seemed to be held in a vicious circle; exhibitors were afraid to raise the admission price, yet the fee was too small to pay for a better theatre or to justify spending more money for better pictures. Between 1910 and 1912 attendance actually began to fall off; even the public whose attention the "nickelodeon" as it was called in the United States, sought to challenge, appeared to grow tired of what, after all, was only an attempt to compete with the old-fashioned "dime novel" and "penny dreadful." A few far-sighted producers perceived that radical measures must be taken if the commercial possibilities of the motion-picture were to be advanced beyond those of a third-rate vaudeville attraction. The first step was to break down the prejudice of recognized artists, for as long as the cinema was held to be an object of ridicule, beneath the dignity of persons of artistic or cultural pretensions, it was hopeless to try to interest the public at large in the new art. An American producer accordingly set about to persuade Mme. Sarah Bernhardt to appear in moving-pictures, his theory being that if the best-known living actress should in this way give her sanction to the cinema the rest would be easy. Mme. Bernhardt, it is said, was won over on the plea that she ought to leave future generations some permanent record of her great art. The result marked something like an epoch in the history of the motion-picture; the old-time prejudice began gradually to give way, and the cinema, now certain of its ability to pay high rewards to popular actors, was soon attracting some of the best theatrical talent. Money was lavishly spent on huge productions that required six months or a year to complete; and a finished picture was likely to cost from \$100,000 to \$200,000 instead of from \$20,000 to \$30,000 as formerly. The Bernhardt films—*Camille* and *Queen Elizabeth*—were followed by such productions as *Quo Vadis*, *Les Misérables*, *Taxi of the D'Urbervilles* (with Mrs. Fiske), the Italian film *Cabiria*, written especially for the cinema by Gabriele D'Annunzio, and *The Birth of a Nation*, produced by D. W. Griffith. *Cabiria* and *The Birth of a Nation* deserve especial notice aside from their excellence as dramatic spectacles, because it was with these films particularly that the first effort was made to compete directly with the legitimate theatre; not only were they presented with full orchestra accompaniment in theatres hitherto given over to the spoken drama, but admission prices were raised to the highest scale for Broadway or West End productions. The success of these ventures had the effect of raising the standards of the cinema theatre in every direction; better theatres adapted solely for motion-pictures were built, permanent orchestras installed, prices increased, undesirable patrons barred; and exhibitors who had formerly looked for support from the riff-raff of the town discovered it was more profitable to appeal to the less impetuous and more self-respecting classes of the community.

There followed a period of keen competition with the legitimate drama. In many communities the motion-picture entirely usurped the place once held by the older art. Many

stock companies were forced out of existence, while the prospect of making a profitable tour with a metropolitan success was rendered more and more precarious.

An American dramatic critic has cited the case of his home town, Pittsfield, Mass., a city of 40,000 pop., and the situation that developed there may be taken as typical of what was happening all over the United States and elsewhere as well. Before the advent of the motion-picture Pittsfield had one theatre devoted to the legitimate drama; here were presented at intervals many of the plays that had attained success on Broadway. But the cinema changed all that; the one legitimate theatre was transformed into a motion-picture "palace," and four new "movie" theatres were opened. Friends of the cinema urged that the casualties brought about by the onward sweep of the new art were on the whole richly merited. Certainly the grave apprehensions once entertained for the future of the dramatic art were ill-founded; it was natural that the new form of amusement should menace the existence of the cheaper and usually inferior grades of theatrical production, but it became equally evident that each form of dramatic story-telling had its place, and neither one, if properly conducted, need fear the other. It might even be urged that in some respects the competition produced a beneficial effect on the stage. The alleged menace of the cinema came into prominence in a new form in 1919 when an American film company (Famous Players-Lasky) purchased the theatrical business of Charles Frohman, Inc., which included control of the Empire theatre in New York City. It was assumed that this invasion of the legitimate stage might result in making the latter a mere appendage of the cinema theatre, but less than a year after the purchase of the Empire Jesse L. Lasky confessed that "the experiment has not been a great success; we have found that the screen can borrow very little from the stage" (*North American Review*, Aug., 1920).

*Technique of Production.*—While aesthetic theory and practice remained in a somewhat chaotic state, the technique of production had been brought to a very high degree of perfection. In 1920 at least 80% of American films were produced in or near Los Angeles, where the brilliant sunlight makes it possible to operate the cinema camera almost continuously without the aid of expensive artificial lighting. In the early days whole film companies were transported to the supposed scene of the action, even when the scene was laid in a foreign country; after the outbreak of the World War, however, this practice was abandoned, and remote scenes came to be represented as nearly as possible by the aid of the carpenter and scene-painter. A thousand workmen would sometimes be employed to construct a single sham village, while theatrical agencies were developed to supply almost every variety of foreign "type" that the imagination of the scenario writer or the exigencies of production could demand. Nothing better illustrates the illiteracy that still clung to certain phases of the business than the absurdities and anachronisms which these made-to-order settings not infrequently disclosed; as, for example, that widely exhibited picture in which the great pyramid appeared with certain improvements that Cheops had neglected to provide, notably a very convenient stairway rising to the top.

An early discovery was that the film would lend itself to a great variety of tricks. A typical example very common in "slapstick" comedy, was that in which a man, caught under the wheels of a steam roller, is merely flattened out by the experience, and by means of a seeming piece of legerdemain is restored to his normal shape. It is hardly necessary to explain that in taking such a picture the camera is stopped at the appropriate moment and a dummy substituted as the victim of the steam roller. Another artifice introduced at the proper juncture certain ghost-like figures which hover in waneany fashion about the scene, or still more uncannily, perhaps, shows us an actor apparently shaking hands with himself. In each case the effect is produced by taking two pictures on the same film (or sometimes by printing two negatives on the same positive). It is an artifice which was sometimes employed by actors to play two important rôles in the same scene; an actress, for example, would appear as both mother and daughter. The most successful of such pictures, however, scarcely ever rose above the level of an interesting *tour de force*. Other peculiar effects were produced by increasing or decreasing the speed with which the film is normally run through the camera. Increasing the speed in the camera reduces the relative rate of projection; this has the effect of separating each motion of an object into its component parts, and the result is not only interesting in itself but valuable for scientific and educational purposes. The wing movements of a bird, for instance, can be examined in a manner that would otherwise be impossible. By the reverse method, the opening of a flower can be presented continuously within a few minutes, though the separate pictures may have been

taken at the rate of one an hour over a period of days or weeks. By the use of magnifying lenses minute organisms could be photographed; and similarly, by employing telephoto lenses, motion-pictures showing various heavenly bodies could be obtained. In farcical or melodramatic films the ability to increase relative speed was employed to make various "stunts" involving horses, railway trains and automobiles seem more dangerous than they really were. Another illusion often used for the same purpose is that obtained by projecting the film backward. By this means a man is made to seem to jump to the top of a building or to defy the law of gravitation in some equally astonishing manner. It is a trick also employed in those pictures in which knives are apparently thrown with such skill that they almost, but do not quite, strike a person standing against a wall; the scene actually photographed is one in which the knives are being withdrawn from the wall by fine, black threads. For a few years these artifices were in great vogue, but they presently grew tiresome, especially after audiences learned that they were frequently victimized by elaborate pieces of deception. One result was to discount nearly every scene in which an actor performed a seemingly hazardous feat; audiences refused to be thrilled, and such "stunts," fortunately for the artistic advance of the moving-picture, fell somewhat into disrepute. Nevertheless there were film companies which continued to exploit devices of this kind, and a special class of performers, known as "hazard people," was employed.

The possibilities of the animated cartoon were first suggested by the well-known illusion in which chairs and other objects are made to seem to move of their own volition. This illusion was effected by stopping the camera while the position of the object was actually being shifted. The animated cartoon is achieved somewhat similarly by photographing a series of drawings, each showing a slight advance over the other. In the earliest examples as many as 8,000 separate drawings were made for each 500 ft. of film, and the process, as thus evolved, was extremely slow and laborious. Later methods were developed whereby only moving parts of the picture were redrawn, and in this way the number of drawings could be reduced to less than one thousand. Even with this simplification a staff of artists was required to complete an animated drawing or cartoon, and the artist to whom it was attributed rarely did more than furnish the outline of the story or a few preliminary sketches. The method employed in making animated cartoons was soon adapted to other subjects; it was found of particular value in illustrating new inventions, or in depicting the operation of certain kinds of mechanism too intricate to be easily photographed from original models.

Early pictures purporting to be taken under the sea were actually photographed through the side of a glass tank. In 1913, however, the so-called submarine tube, which had been devised to lower beneath a boat for observation purposes, was adapted for cinema photography, and the first actual submarine pictures were taken. By this means the under-sea scenes of Jules Verne's *Twenty Thousand Leagues Under the Sea* were filmed, and later some remarkable pictures were made of divers fighting with sharks. Interesting cinema views were also obtained of many varieties of ocean fish and submarine plant life.

*Educational Use.*—With the development of cinema technique it came to be seen that the moving-picture might be used as a valuable aid to education. The hopes of many people that the commercialized cinema would undertake this work on a large scale were of course not realized. Nevertheless, in most cinema theatres it became customary to exhibit excellent pictures of current events, travel, or similar subjects in addition to the regular programme; and the educational value of such pictures should not be overlooked. The British Cinema Commission of Inquiry found that, other conditions being equal, the fund of general knowledge possessed by children who frequent the pictures is far wider and far richer than that possessed by those who do not. This information covered a wide range, including facts of geography, literature, natural science, industrial processes, social life, current events, etc. Moreover, the ideas formed from a moving-picture were often demonstrably more accurate than those which the children had previously acquired from an oral or printed description.

It is obvious that, wherever the intention is to impart information which is concerned primarily with visual impressions, the motion-picture is greatly superior to any other form of instruction. Words are only an inadequate substitute for pictures in giving correct ideas of landscape, natural or mechanical processes, foreign customs and the like. For this reason, ten minutes in a motion-picture theatre will often give a better grasp of such subjects than several hours devoted to text-books. Knowledge acquired in this way has a vividness and an interest that do not attach to other forms of instruction; consequently it is acquired with less mental friction and with less



likelihood of its being forgotten. During the World War, the Governments engaged in that conflict produced thousands of war pictures to encourage enlistment and keep up morale; and the cinema proved itself to be one of the most potent methods of propaganda in reaching the mass of the people. Films taken on the battle-field, moreover, will acquire more and more historic interest as time goes on. Such pictures, displayed in connexion with the course of study at military colleges, have a value above mere entertainment. Practically all Governments, therefore, provided special archives for preserving motion-picture films, especially those dealing with military subjects. The taking of pictures of current events was developed as a special branch of the motion-picture industry. Certain companies perfected organizations with cameramen acting as their representatives all over the world, and facilities were provided for the rapid transportation and development of news films. These companies began to compete to get their pictures into the theatres at the first possible moment, and motion-pictures of important events were frequently exhibited within an hour or two after the event had taken place. Sometimes pictures showing earlier phases of a prize fight, an inaugural ceremony or occurrence of like nature were displayed even while the event itself was still in progress.

The U.S. Government was probably the first to use the cinematograph for the purpose of disseminating agricultural information among farmers. In 1920 the Department of Agriculture had in circulation approximately 100 cinema pictures showing such subjects as *How to Select a Laying Hen* and *The Story of Cotton*. The films were produced under Government supervision and developed in Government laboratories, which then had a capacity of one reel a week. Towards the close of the decade many private institutions were also undertaking the production of moving-picture films for educational purposes, and the installation of projecting machines in schools and churches was becoming rather general. In 1920 there were in the United States 1,500 schools, universities, and similar institutions so equipped, while more than 2,000 had arrangements with local theatres for the exhibition of pictures of special value in connexion with educational work. About 2,000 churches occasionally showed moving-pictures either at the church proper or at some outside place under church supervision. In order to supply schools and churches the "film library," devoted largely to educational subjects, was developed and gave promise of serving a need analogous to that supplied by the circulating library of books. These libraries were at first instituted as commercial enterprises, but in the United States in 1920 there was at least one organization which supplied films gratis to institutions that offered to exhibit them free of charge.

**Censorship and Regulation.**—A demand for the regulation, supervision and censorship of the cinema theatre arose very soon after the film began to be used for narrative and dramatic purposes. Regulation was first concerned with construction of the theatre, the elimination of the fire hazard, and the supervision of audiences; then it came to be felt that the chief danger lay in the pictures themselves. Social workers in nearly every country conducted an agitation for a censorship that would prevent the showing of objectionable pictures.

One of the first countries to establish a national censorship was Sweden (1911); other countries soon followed—Spain (1912), Italy (1913-4), France (1916). Censorship was also instituted in Russia and Japan; in the latter country the prohibitions included anything that "contradicts morality and consequently the principle that good brings its own reward and evil its own punishment."

In Great Britain the Cinematograph Act of 1909 provided for the licensing of cinema theatres but not for censorship. As a result, however, of the discussion incident to the importation, chiefly from France and America, of certain objectionable films, the Cinematograph Exhibitors' Assn., with the approval of the Home Secretary, established an independent Board of Film Censors. Exhibitors were not of course obliged to accept the decisions of this Board, yet before the close of the decade

1910-20 more than 97% of the films exhibited in the British Isles were first reviewed by the Board of Censors.

In 1920 the Cinematograph Exhibitors' Assn. adopted a resolution providing for the expulsion of any member who refused to submit to the censorship of the Board. It might have been expected that such censorship, in view of its close connexion with the trade itself, would prove careless and ineffective. It was, however, the opinion of the Cinema Commission of Inquiry, which conducted a very careful investigation of the whole subject in 1917, that the work of the Board was for the most part conscientious and commendable. This commission had been instituted by the National Council of Morals; its report, *The Cinema*, already referred to, is a valuable treatise on many aspects of the moving-picture industry. One of its conclusions was the recommendation of a State censorship, largely on the ground that the authority of the State could be exercised more effectively than that of an independent board. Testifying before the commission, T. P. O'Connor, who had been appointed president of the Board of Censors in 1916 (following the death of G. A. Redford, his predecessor), stated that films were censored with respect to a series of prohibitory regulations, 43 in number, of which the following are typical: "Indecorous, ambiguous and irreverent titles and sub-titles. Irreverent treatment of sacred subjects. The *modus operandi* of criminals. Cruelty to young infants and excessive cruelty and torture to adults, especially women. Nude figures; impropriety in dress or conduct. Grossness, murders, strangulation scenes, executions. References to controversial politics. Subjects dealing with the drug habit, white-slave traffic, race suicide, etc. Illicit sexual relationships; suggestive scenes of immorality; incidents suggestive of incestuous relations. Scenes tending to disparage public institutions or characters. Materialization of the conventional figure of Christ."

Besides showing much good sense, these prohibitions indicate to what lengths even a moderate censorship can go; if logically applied such rules would bar many of the plays of Sophocles, Shakespeare and Ibsen.

The British Board of Censors exercised no control outside of the British Isles. In Canada in 1920 each province had a board of censors appointed by the lieutenant-governor in council; in general the censorship was very rigid, but the fact that a film had been approved by the authorities of Ontario, for example, was no guarantee that it would be passed by the board in Quebec, or vice versa. Elaborate regulations for censorship were adopted by New Zealand in 1916, and in 1920 State censorship of films existed in many parts of the British Empire, including India and New South Wales.

In the United States, a non-official censorship, subsequently known as the National Board of Review, was instituted in 1909 by the People's Institute of New York. Its review committee (unpaid) was in 1920 composed of 140 representative citizens, many of whom were engaged in social welfare work. The American Board, unlike its British counterpart, had no direct connexion with the cinema industry; its revenues were derived in part from contributions and in part from a flat charge of \$6.25 (1920) per reel which was assessed against the producer for the review of his pictures. In 1920 nearly 6,000 reels were so reviewed, representing, it is said, more than 99% of the films exhibited in the United States. The censorship exercised by the American Board was on the whole noteworthy for its enlightened character, but while the Board won support in many communities, there were others which seemed to think its supervision was either too lenient or not suited to local needs. By 1921 six states—Ohio, Pennsylvania, Maryland, Kansas, New York and Massachusetts—had established official censorship boards, and agitation for similar laws was in progress in many other states. Certain groups were also advocating a national board of censors to be appointed by the president. National laws to 1921 consisted only of general prohibitions against the shipment of improper films in interstate commerce, though in 1918 the Secretary of the Treasury was empowered to censor imported films.

For the most part, the cinema industry strongly opposed the extension of laws for official censorship of motion-pictures, and the objections put forward were often well founded. For people of the Anglo-Saxon tradition it is hard to justify the establishment of a bureaucratic control over any form of artistic or intellectual expression, whether the medium be the press or the stage. It should be said, moreover, that opposition to censorship by no means involves a covert desire for licentious pictures; even without censorship the exhibitor is fully responsible for the films he shows. Legalized censorship removes the opportunity to show improper films; it is

preventive. Its great danger is that it may become rigid and arbitrary. Special reasons, however, were advanced why in the case of the moving-picture preventive action should be taken. One of these was that the cinema theatre makes an extraordinary appeal to children, who comprise a large percentage of the average neighbourhood audience. But it could be answered that if the cinema was ever to become a mature art, it could not forever be restricted by standards of what might and might not be good for children. The best solution here seemed to lie in providing special performances for children; no good reason appeared why children should be encouraged or even permitted indiscriminately to attend the cinema theatre. A better plea for censorship was that the industry, having arisen in less than a quarter of a century, was still in a formative condition, without adequate artistic and moral standards. It was urged, therefore, that censorship was necessary not only to protect the public but to protect the producer against his inability to perceive his own best interests. Such an argument clearly anticipated a period when censorship would be unnecessary; unfortunately experience points to the difficulty of abolishing any kind of bureaucratic agency when once it has become established. The continued existence of the British dramatic censorship, despite very great efforts to modify its powers, affords an excellent illustration of the tenacity of Government bureaus. It should be noted also that in the United States the censorship laws seemed to be designed partly as revenue measures, which of course still further entrenched them against attack. For these reasons the voluntary censorship undertaken by the Board of Film Censors in England and the National Board of Review in the United States would on the whole seem preferable to other methods of preventive supervision. In this connexion the following excerpt from the official statement of the American Board is significant: "The National Board's standards are, of course, progressive and will change with the lapse of time. . . becoming more ideal as the motion-picture in America emerges from its present condition as a new art. Moreover, the increased experience of the producers, the development of motion-picture artists, the classification of the theatres, the influence of more cultivated audiences, and the popular adoption of motion-pictures into education, all of which is even now in progress, will in time bring about conditions so different from the present that regulation may perhaps not be necessary."

**Artistic Value.**—The close of the decade was marked by various controversies as to whether the cinema could be classified as an art. That discussion was in itself a valuable indication of the improving status of the moving-picture; ten years earlier the cinema was either ridiculed or ignored. Later critics very naturally sought to establish their case against the cinema on the obvious fact that a majority of the films were crude and childish, mostly slapstick farce and sentimental melodrama; but an argument evolved in this fashion has little to commend it; doubtless in the England of the 15th century it seemed equally impossible that the crude mystery and morality plays of the day should ever give rise to distinguished art. Yet these crude efforts were the precursors of the drama of Marlowe, of Jonson and of Shakespeare. This is not to say that friends of the cinema are looking forward to a Shakespeare of the films; the artistic values that can be achieved in the motion-picture are not commensurable with those which pertain to the written drama. What is contended is that, considered solely as a method of telling a story, the motion-picture is capable of achieving highly artistic results. Even sentimental melodrama as produced in the cinema became a more artistic type of narrative than the old popular melodrama of the stage. But the best producers were not content to have made only this degree of progress, and their finest achievements at least foreshadowed the development of singularly beautiful and expressive art.

Action and setting constitute the chief means of this art, and in both elements it has advantages over the older forms of narrative. The cinema can present action more successfully than the novel and hardly less effectively than the drama. In the ease with which it can represent and control the element of setting it has an immense superiority over both the novel and drama, though its possibilities in this direction were only beginning to be appreciated. Some writers, notably Prof. Hugo Münsterberg in his interesting study, *The Photoplay* (1916), insist that the essence of the new art lies in its ability to triumph over the ordinary limitations of mundane existence. "The photoplay," says Münsterberg, "tells us the human story by overcoming the forms of the outer world, namely, space, time and causality, and by adjusting the events to the forms of the inner world, namely attention, memory, imagination and

emotion." The plasticity of the motion-picture medium, its freedom from merely conventional restrictions of time and space, undoubtedly give fresh scope to the imagination and the power to weave new patterns out of the materials of existence. Possessing these advantages, the cinema lacks the means to tell any appreciable part of its story in words. Failure to appreciate the artistic possibilities of the moving-picture often arose from a failure to perceive that it must be regarded as an art quite different in method, if not in purpose, from that of essentially literary forms, particularly the spoken drama. It is not a literary art. It cannot rely on literary methods. This explains the lack of success that attended the efforts of many literary men, novelists and dramatists, to use this new medium. Its central purpose, namely to arouse emotion, is identical with that of the spoken drama; it is perhaps more amenable to fundamental laws of dramatic composition than many producers and directors seemed to realize. But in most respects it differs more widely from the accepted dramatic form than Shakespeare differs from Sophocles or Ibsen from both. In virtually surrendering dialogue, the motion-picture surrenders a form of expression upon which the dramatist relies very largely for the presentation of character and the clash of character; it follows that a scene representing mental conflict, for example, must either be inadequately represented in the moving-picture or expressed in a different way.

For this reason, the production of a successful motion-picture play makes the very highest demand on the skill and imagination of the scenario writer, the director, and the actor. In the composition of the story every scene and every element of the scene must possess an expressiveness which is quite unnecessary where words can be used to cover defects of action or setting. The art of suggestion must be pushed far beyond the conventional limits of the legitimate stage; an attitude, a look, a gesture, a bit of pantomime to disparage such a method; in ordinary life we discern the nuances of character quite as much from facial expression as from what we are told by the person himself; the light in the eye often illuminates the mind better than the spoken word. Setting, also, may be made to reflect character; it may show the world as the protagonist of the drama himself sees it, sometimes twisted and distorted, sometimes fair and alluring. Here at least is an opportunity to do what the legitimate drama could never do. Setting likewise may advance the plot; as Otis Skinner points out, sometimes a glove, a pistol, an empty chair, will tell a better story than action. To a much greater extent than the drama, the successful motion-picture requires the co-ordination of the efforts of the author, the actor and the producer; a play may have an existence of its own without ever having been produced on the stage, but a moving-picture scenario is the barest of skeletons before it is acted in front of a camera. The photoplay is thus a composite art, almost equally dependent on its various elements. Some advance had been made in the decade 1910-20 in achieving a successful co-ordination of these elements, but no completely adequate method or procedure for securing this result had been evolved, so that good acting was frequently wasted on ridiculous scenarios, while good stories were made childish by incompetent direction.

**Film Actors.**—In an art so new, it is not surprising that the greatest reputations were made by actors whose appeal to the public is less a matter of circumstance than that of the scenario writer or the director. By reason of the extensive popularity of the motion-picture the names of Mary Pickford, Douglas Fairbanks, and Charles Chaplin had a renown that was no less than world-wide. Miss Pickford (family name Smith) was born in Toronto, Can., April 8 1893, the daughter of a character actress. She made her debut on the stage at the age of five, but her first marked success was in motion-pictures, and she afterwards appeared as leading woman in many highly successful photoplays, among them *Tess of the Storm Country*, *Cinderella*, *Pancho the Cricket*, *Rebecca of Sunnybrook Farm*, etc. For many she typified the charm of innocent girlhood. On March 28 1920 she married Douglas Fairbanks. She was in 1920 head of the Mary Pickford Film Company. Fairbanks, who was born May 23 1883 in Denver, Col., attended for a time the Colorado School of Mines. He appeared in a minor rôle on the New York stage in 1901; later he was "starred" in several comedies and musical pieces, after which he left the stage for motion-pictures, where his engaging smile and athletic prowess stood him in

good stead. In 1916 Fairbanks organized his own producing company. At the age of seven Charles Spencer Chaplin (born in 1888 near London) first appeared on the London vaudeville stage. A piece called *A Night in an English Music Hall* brought him to the United States, and in 1914 he became a cinema actor for the Keystone Film Co., under whose auspices he quickly showed his genius for comedy, though his early rôles were principally those of the inebriate clown, borrowed or imitated from the vaudeville stage. In succeeding years he performed in motion-pictures for the Essanay Co., the Mutual Film Corp., and the First National Exhibitors' Circuit; it is stated that in 1917 he received \$1,000,000 from the last-named organization for making eight two-reel pictures. He afterwards constructed a motion-picture plant at Los Angeles and undertook the direction of his own pictures.

Before the invention of the motion-picture the art of acting was perhaps the most ephemeral of the arts. We have been told that David Garrick, for example, was a great actor, but we have no means of judging for ourselves. The motion-picture can now give to the actor's art a permanence that is to some degree analogous to that of the printed book. Up to 1921 it was, however, a more conditional permanence, for the reason that cinema film as then manufactured had much less enduring quality than the printed page; a book can be preserved for centuries, but the commercial film of the day was not expected to remain clear for more than 15 years. Films kept longer than that showed signs of rapid disintegration. A continual renewal of old films by making new copies was therefore the price of keeping a permanent motion-picture record. Many old films were accordingly allowed to lapse, and it is obvious that accident will play a large part in determining what films shall be preserved as the years go by. But with good fortune, some motion-pictures may achieve an immortality comparable with that of the great works of arts or letters. It would be more than hazardous to say that the cinema, in the brief period of its existence, had yet produced any picture which deserved immortality. Still, every one who is interested in this new art would wish to make a few exceptions, if only for the sake of their historical importance.

(H. C. R.)

**CITY GOVERNMENT (UNITED STATES).**—Lord Bryce's *American Commonwealth* (1888) may be said to mark the turning point in the consideration of city problems in America. From the end of the Civil War in 1865 to 1888 the United States was engrossed in problems of readjustment, reconstruction, transportation and internal development. Municipal affairs, where not wholly neglected, were at low ebb and in the hands of selfish political organizations, whose interests were wholly those of personal aggrandizement and profit. Lord Bryce's criticism stung the country into consciousness of the shortcomings.

A national conference on city government was held in Philadelphia in 1894, out of which grew the National Municipal League. Its early meetings were devoted to a statement of conditions and to a discussion of the lessons they taught. Publicists and students were not in a position to agree upon a statement of belief, mainly because they had not given to general plans the necessary attention and study; their experience had been purely local. There was no regular form of American municipal government, and the greatest diversity of types, although the general tendency was toward a federal plan modelled on that of the national Government with a division of functions (legislative, administrative and judicial). Out of the League's efforts grew a "municipal programme" the fundamental features of which were that every community should have the right of self-government in local affairs without the interference of outside governmental or party machinery; that the city's public property in land, and especially its franchise rights, should be preserved unimpaired; that all barriers should be removed which prevented the popular will from expressing itself freely and effectively; that municipal administration should be conducted in the main by a class of public servants who by reason of experience and special training were particularly fitted for their official duties; that official responsibility should be so placed, through simplification of governmental machinery and full publicity of accounts, that the people could hold their public servants to the execution of the public will with the least possible delay and uncertainty.

In the year in which this programme was adopted (1900) the Galveston flood nearly destroyed that city. Among other

things swept away was the typical old-style mayor and council form of government, which was replaced by a commission of five men appointed by the governor of Texas. This commission worked so swiftly and efficiently, and with so much less annual cost, that, after the emergency passed, an attempt was made to continue it with a commission of five members, three appointed by the governor and two chosen by popular vote. A court decision declared such appointments to be unconstitutional and the entire commission forthwith became elective. To the surprise of many observers, no demoralization ensued, and through successive elections the changes in the personnel were slight.

In 1908 Des Moines adopted the Galveston plan, with the addition of the initiative, referendum, recall and non-partisan primary. This broader plan was widely copied, and 481 cities and towns of 2,000 and over by Jan. 1 1921 had adopted it.

The following cities of more than 50,000 inhabitants (census of 1920) were in 1921 operating under this form: Buffalo, N. Y.; Dallas, Tex.; Erie, Harrisburg, Wilkesbarre, York, Lancaster, McKeesport and Reading, Pa.; Jacksonville, Fla.; Kansas City, Kan.; Lawrence and Lynn, Mass.; Newark, N. J.; New Orleans, La.; Portland, Ore.; St. Joseph, Mo.; St. Paul, Minn.; Salt Lake City, Utah; Seattle, Spokane and Tacoma, Wash. There were in the same year 56 cities and towns in Illinois under commission government; Texas followed with 48; Kansas had 42; New Jersey 38; Pennsylvania 32; Oklahoma 23; California 17; Michigan 17; South Dakota 16; Alabama 13; Louisiana 13; Tennessee 13; Florida 12; Iowa, Missouri, North Dakota and Washington to each. The number per state gradually decreased until in Arizona, Connecticut, Maine, Maryland and New Mexico there was one each. There was none in New Hampshire, Vermont, Rhode Island, Delaware, Virginia, Georgia, Indiana, Arkansas, Wyoming, and Nevada.

Few changes of importance were made in the Des Moines model for several years after 1908 (except the preferential ballot first added by Grand Junction, Colo., 1909) until the appearance in 1913 of the first modification providing for a city manager. Out of this grew a city-manager form of commission government, which the National Municipal League recommended to charter-makers, then multiplying in great numbers due to the growing dissatisfaction with existing conditions. A second "municipal programme" formally adopted by the National Municipal League in 1914, definitely embodied the city-manager plan and later recommended that the council or legislative body be elected on the principle of proportional representation.

The city-manager movement is justly regarded as the best fruit of the movement for better municipal government. It embodies the short ballot, responsiveness to public opinion, concentration of executive power and responsibility, expert administration of city affairs, and elimination of legislative control over the administrative, all essential principles of sound governmental practice. The success of the plan has been abundantly proved, although here and there expectations, because unreasonable, have not been met. Like other governmental agencies it is open to change and improvement, but it stands as the big contribution to political science of the past quarter of a century. Moreover, its application to an increasing number of cities is developing municipal policies as perhaps no other single factor does. City-planning, zoning, budget-making, the preparation of adequate and carefully devised plans for transportation, intelligent housing, have all been stimulated by the introduction of experts in municipal affairs.

On Jan. 1 1920 there were 203 cities, according to the City Manager Association roll, operating in this form; Michigan leading with 27 cities; California, Texas and Virginia following with 19 each; Iowa and Ohio 12; North Carolina 9; Florida 8; New York 6; Pennsylvania and Georgia 5. There was none in New Hampshire, Rhode Island, Delaware, Indiana, Illinois, Wisconsin, North Dakota, Nebraska, Alabama, Mississippi, Montana, Wyoming, Nevada, Idaho, Washington. The following cities with a pop. of 25,000 or more (census of 1920) were in 1921 administered by city managers: Alameda, Pasadena, Sacramento, San Diego and San Jose in California; Colorado Springs, Colo.; Tampa, Fla.; Dubuque, Ia.; Waltham, Mass.; Bay City, Grand Rapids, Kalamazoo, Muskegon and Pontiac, Mich.; Niagara Falls and Watertown, N. Y.; Akron, Ashtabula, Dayton, Lima and Springfield, O.; Newkoge, Okla.; Altoona, Pa.; Beaumont, Tex.; Lynchburg, Newport News, Norfolk, Petersburg, Portsmouth, and Roanoke, Va.; and in West Virginia, Charleston and Wheeling.

Home rule for cities, a farcry when Lord Bryce's book appeared, was in 1921 the guaranteed constitutional right of the cities of one-quarter of the states in the Union and bade fair to become the policy of many more. It represented a great gain both for municipal government and for an efficient administration of state affairs. Improvements in the personnel of city officials have not kept pace with improvements in other directions, although substantial changes for the better are everywhere to be noted. There can be no lasting improvement in this connexion until the short ballot becomes an established fact. This change will come less quickly than the others because of the "vested interests" of the great political organizations, which will yield with the greatest reluctance, for the short ballot means the substitution of citizen management for party organization. Whether the latter would ever cease to be necessary was still in 1921 a question upon which there was a sharp difference of opinion. There is no doubt, however, that party ties, particularly in local contests, are far looser than they formerly were. "Municipal affairs" was in 1921 a phrase which included a multitude of things that a generation earlier were not discussed even academically. One has only to study the budget of the present-day American city to appreciate how manifold those affairs have become. Not only numerically but intrinsically they have grown in importance and this constitutes an important feature of the present public interest in them. The municipal activities of American cities are numerous and varied. Prof. Frank Parsons, in summing them up, declared that the following subjects were held to be proper public purposes and proper subjects of municipal ownership and control: "Roads, bridges, sidewalks, sewers, ferries, markets, scales, wharves, canals, parks, baths, schools, libraries, museums, hospitals, lodging houses, poor houses, police, jails, cemeteries, prevention of fire, supply of water, gas, electricity, heat, power, transportation, telegraph and telephone service, clocks, skating rinks, musical entertainments, exhibitions of fireworks, tobacco warehouses, employment offices." The three decades following 1890 witnessed a steady growth toward responsible, efficient democratic government among American cities. (C. R. W.)

**CLARETIE, JULES ARSÈNE ARNAUD** (1840-1913), French man of letters (see 6.436\*), retired from the administration of the Théâtre Français in 1913. *La Vie de Paris* was completed in 1913, and published in 21 vols. in 1914. He died in Paris Dec. 23 1913.

**CLARK, CHAMP** (1850-1921), American politician, was born in Anderson co., Ky., March 7 1850. He first entered Kentucky University but finished his course at Bethany College in 1873. The following year he was elected president of Marshall College, West Virginia, and one year later was admitted to the bar. After 1880 his law office was in Bowling Green, Missouri. He was city attorney for Louisiana (Mo.) and Bowling Green from 1878 to 1881, was prosecuting attorney for Pike co. 1885-9, and then for three years was a member of the Missouri House of Representatives. He was a member of Congress from 1893 to 1895, and from 1919 to 1921, being Speaker from 1911 to 1919 and minority leader thereafter; he was defeated in the election of 1920. At the Democratic Convention for the nomination of a presidential candidate held at Baltimore in 1912, he led on 27 ballots, and had a clear majority on eight, but he was finally defeated by Woodrow Wilson of New Jersey. He died in Washington, D.C., March 2 1921.

**CLARKE, ALEXANDER ROSS** (1828-1914), British soldier, was born Dec. 16 1828. He entered the Royal Engineers, and in 1854 was placed in charge of the trigonometrical operations of the ordnance survey. He retained this position until 1881. He was one of the British representatives at the international geodetic congress held in Rome in 1883, and in 1887 received the Royal medal of the Royal Society. Colonel Clarke was a recognized authority on geodesy, and made valuable contributions to the subject. He died at Reigate Feb. 11 1914.

**CLARKE, SIR CASPAR PURDON** (1846-1921), English art expert, was born in London Dec. 21 1846. Educated privately at Sydenham and Boulogne. In 1862 he entered the art schools

at South Kensington and was trained as an architect. In 1865 he entered the Office of Works, and in 1867 was attached to the works department of the South Kensington museum. He travelled extensively for the museum, purchasing objects of art, and at the same time carried on his profession as an architect. In 1883 he became keeper of the India museum at South Kensington, in 1892 keeper of the art collections at South Kensington, in 1893 assistant-director, and in 1896 director. This post he held until 1905, when he became director of the Metropolitan museum, New York, resigning in 1910. He was knighted in 1902. He died in London March 29 1921.

**CLARKE, SIR EDWARD GEORGE** (1841- ), English lawyer and politician (see 6.444), retired from the bar in 1914. He published in 1918 an autobiography, *The Story of my Life*.

**CLAUSEN, GEORGE** (1852- ), English painter (see 6.467). His recent work has been chiefly landscapes, such as "The Fields in June" (1914), now in the Cardiff gallery, and "Midsummer Dawn" (1921), but has also included portraits and figure work such as "The Window" (1912), now in Cape Town gallery. For the Imperial War museum he painted the large "Gun Factory at Woolwich Arsenal" (1919), broadly decorative but very refined in handling. His decorative work also includes "Renaissance" (1915) and decorations for the Hall at High Royd, Huddersfield, consisting of life-size figures in lunettes. He was elected R.A. in 1908, and is a member of the R.W.S. He is represented in the Tate gallery by "The Girl at the Gate" (1890) and "The Cleaners Returning" (1908).

**CLEMENCEAU, GEORGES EUGÈNE BENJAMIN** (1841- ), French statesman (see 6.482). When Clemenceau resigned the French premiership in July 1909, he had already played as great a part in his country's history as would have satisfied the energies and ambitions of most men. He might be driven from office; nothing could force him to give up the fearless use of his critical gifts as a speaker and as a writer. Out of office he remained a formidable figure. As a senator he did his utmost to defeat Raymond Poincaré in the presidential election of 1913, and rallied against him all the forces of French radicalism. Clemenceau's candidate, Jules Pams, was adopted by the party caucus, but, in spite of Clemenceau, Poincaré maintained his candidature at Versailles and was elected. There were many then who felt that at last "the Tiger" had been killed. On the boulevards, young students who, years afterwards, were to seek from Clemenceau all their hope and inspiration, paraded shouting "Down with Clemenceau!" The old fighter refused to accept this defeat. He founded *L'Homme Libre*, in which to carry on his warfare against Poincaré. Every morning he poured a column of acid upon the new President of the republic, but soon found himself forced by patriotic honesty to support with all his strength the chief measure introduced to Parliament during the first year of Poincaré's term of office—the Three Years' Military Service bill. He belonged to the generation of defeat, and, while in no way a *renard*, believed, in spite of his cynicism, that injustice cannot be permanent, and therefore desired to see his country strong. He, more than any other Frenchman, had studied and appreciated the meaning of German military preparations, and to him also belongs the honour of having been calmly consistent in warning France of what was to come and exhorting her to gird up her loins. He fought for the Three Years' Service bill with every weapon in his armoury, and it was he who opened the eyes of many Radical opponents of the measure to the danger of allowing considerations arising from the approaching elections to cloud their judgment on a matter of life or death to the country.

On the very eve of the World War in July 1914, speaking in the Senate, he insisted upon steps being taken to press forward at top speed the realization of the artillery programme. His war writings began long before war was declared, and there are some worthy of a place in history. Among them were the articles published by *L'Homme Libre* under the splendid titles of "Vouloir ou Mourir," "Pour Etre," "Triompher ou Perir." After the outbreak of hostilities he soon made acquaintance with the stupidity of rigorous censorship, and in Sept. 1914 his paper

\* These figures indicate the volume and page number of the previous article.

was suppressed on account of a violent attack upon the appalling inefficiency of army medical services. With characteristic irony and decision two days later he issued *L'Homme Enchaîné*, a title which was kept until he himself took office on Nov. 16 1917. Each day the censorship had to forge fresh fetters for chaining him. With all the skill of a surgeon Clemenceau laid bare the faults which too frequently characterized French war-leading. Poincaré was the butt for many of his bitterest jibes, and by the savagery of his opinion Clemenceau perhaps shut himself out of office for so long a time. He fought government after government in his paper, but there the censorship put buttons on his foils. His voice, however, could not be stilled in the private proceedings of the Senate. At the beginning of the war he was president of the foreign affairs committee, and when de Freycinet joined the Briand Ministry he also was elected president of the army committee of the Upper Chamber. These two posts gave him an observation post commanding the whole field of war affairs, and his criticisms and suggestions on these committees were invaluable. M. Caillaux, in his defence, *Mes Prisons*, states that throughout the war two policies fought in France for supremacy—his own tendency towards reconciliation with Germany, and peace without victory, to be made very largely at the expense of Great Britain; and the uncompromising faith of Clemenceau that France must fight to a finish, that it would be better for the world and for France that she should go down into dust rather than she should live in dishonourable partnership with injustice. Caillaux's analysis is right in its main perspective, and he is also correct in stating that it was in the spring of 1917 that Clemenceau won his victory. Then it was, without a doubt, that the clear revelation of the results of the doctrine of defeatism startled the people from the war-weariness into which they were slipping.

It was upon the wave of feeling then created that Clemenceau came into power. He had to fight not only Caillaux and his henchmen, who knew that with Clemenceau at the head of affairs their shrift would be short; he also had arrayed against him a legion of self-made enemies and the instinctive distrust of mediocre politicians for a man they knew to be their master. By July 1917, Clemenceau had driven Malvy from office by his charges of negligence in dealing with enemy propaganda. The position of the whole Ribot Ministry was made untenable, and the Painlevé Government was the last barrier erected against Clemenceau. On Nov. 16 1917, he formed his Victory Cabinet. Nearly all the men in it were unknown, and Clemenceau could well have said: "Le Gouvernement, c'est moi."

The story of his ministry is told under FRANCE (*History*). A few facts and dates complete the record. He presided over the Paris Peace Conference, at which he was chief French delegate. On Feb. 19 1919 he was wounded by revolver shots fired at him as he was leaving his house in the rue Franklin, by a young anarchist, Emile Cottin (sentence of death, March 14, commuted to imprisonment for life). He allowed himself to be put forward as candidate for the presidency at the preliminary party caucus meeting on Jan. 16 1920, but, in view of the support given to M. Deschanel, he did not stand for election at the National Assembly of Versailles, and then retired from all public activity. He afterwards traveled in Egypt and India. In June 1921 he was given a doctor's degree at Oxford University.

**CLERK, SIR DUGALD** (1834— ), Scottish civil engineer, was born at Glasgow March 31 1834. He was educated at the West of Scotland Technical College and the Andersonian College. He invented the Clerk cycle gas engine in 1877, improving it in 1878 (see 11.498), and became a recognized authority on internal combustion engines. He also interested himself in motor engineering, acting as judge at the automobile trials at Richmond in 1899 and 1900, and in 1908 becoming president of the Incorporated Institution of Automobile Engineers. During the World War he became director of engineering research to the Admiralty, and until 1919 was a member of the advisory committee for aeronautics to the Air Ministry, and also of the air inventions committee. In 1908 he was elected F.R.S. He was knighted in 1917 in recognition of his work.

**CLEVELAND** (see 6.503); the largest city in Ohio and the 4th in the United States, had in 1920 a pop. of 796,841, a gain of 236,178 or 42.1% for the decade. The area in 1921 was 56-655 sq.m. as against 41 sq.m. in 1910. To the two viaducts across the valley of the Cuyahoga river were added three others, of which the most noteworthy is the High Level bridge, connecting Superior avenue on the east with Detroit avenue on the west. Its central span is 591 ft. long and 96 ft. above water, permitting the tallest masts of lake shipping to pass. The total length, with approaches, is 5,630 ft. and its cost was \$5,407,000.

The centre of retail trade moved steadily eastward, crowding out the large houses with spacious grounds which had made Euclid avenue famous. New residential sections were developed, especially near Wade park and on the heights east of the city. Noteworthy additions were made to Cleveland architecture in the county court house and the city hall (of the uncompleted "Group" plan); in office buildings like the Engineers, the Illuminating, the Leader-News, and the Hanna buildings; in the "Plain Dealer" newspaper building; in the Cleveland Trust Co.'s bank building; in the Museum of Art; and in churches, the Church of the Covenant (Presbyterian), St. Agnes (Catholic), Euclid Avenue Temple (Jewish), and the Amasa Stone memorial chapel of Adelbert College.

The schools were reorganised in 1917 as a result of a "survey." Significant features were the development of junior high schools, of which there were in 1921 sixteen, and the effective establishment of departmental supervision to coordinate, standardize, and improve the work in each study. The cost of instruction in 1919 was \$4,383,924. The Normal school, now the Cleveland school of education, was affiliated with Western Reserve University. To the university were added schools of pharmacy and of applied social science, and a department of religious education. In 1920-1 the university had 243 instructors and 2,027 students. Of other institutions of higher education, Case school of applied science had 67 instructors and 690 students, St. Ignatius College 26 instructors and 560 students, the Cleveland school of art 17 instructors and 547 students. The most important addition to the educational and artistic life of the community was the Museum of Art, located in Wade park. The building, of beautiful classical design, and admirably adapted to its uses, was completed in 1916. By reason of collections already made and additional gifts, the museum at once took high rank. Its directors have sought through classes, lectures, and special exhibitions, to make it a power in popular education and to coordinate its work with that of the schools and colleges. The musical development of the city was stimulated by the creation of a symphony orchestra.

In its charities Cleveland has carried far the principle of co-operation, seeking to obviate through a welfare federation the waste in soliciting contributions. In 1919 and 1920 Community Chests were organized, and sums aggregating \$4,000,000 and \$4,500,000 were subscribed in "drives" to meet the needs of all community activities, not only charities, but also Red Cross, Y.M.C.A. and Y.W.C.A., Knights of Columbus, etc. The Cleveland Foundation was created in 1914, becoming the model for similar institutions in other cities. Its purpose was to enable a competent commission, renewable in part each year, to utilize a portion of funds entrusted to it in inquiries on the best methods of furthering the interests of the community, and, when the funds became large enough, to apply their income directly to schemes of betterment. Under its auspices were conducted in 1916 an educational survey at a cost of \$50,000, a survey for a community recreation programme in 1920, and a survey of the administration of justice in 1921.

Cleveland is the seat of a federal reserve bank. Its two largest banks were in 1921 the Union Trust Co., formed that year by the consolidation of several older banks, and the Cleveland Trust Company. In the same year the city still retained its position as the greatest ore market in the world and also led in many steel products.

The increase in automobile production in the decade closing in 1914 was 486%. The total value of all products in 1914 was \$152,531,000 compared with \$172,115,102 in 1905. Major facilities were developed by the completion of the Government breakwater, 5½ m. long. Passenger steamship service was transferred to a new 5 ac. pier on the lake front, built at a cost of \$500,000.

In accordance with authority conferred by the home-rule amendment of the state constitution, a charter, submitted by a special commission, was accepted by the citizens on July 1 1913. Under its provisions the mayor and the 26 councilmen are the only elected officials. Nominated by petition, all candidates appear on tickets without party designation. Heads of departments and divisions are appointed by the mayor; all other officials are appointed according to the merit system.

The city added to its waterworks a filtration plant, with a total capacity of 150,000 gal. a day. Water is drawn through tunnels from a submerged crib about 5 m. from shore.

The total number of men supplied by Cleveland to the U.S. armies in the World War was 55,000; the total amount subscribed in the Liberty and Victory Loans \$337,041,300. (H. E. B.)

**CLIFFORD, JOHN** (1836—), British Nonconformist divine (see 6.307), resigned his position at Westbourne Park chapel in 1915. He was president of the National Brotherhood Council from 1916 to 1919.

**CLIMATE AND CLIMATOLOGY** (see 6.300).—In climatological progress during 1910–21 certain general tendencies are observable. (1) Increasing emphasis has been laid upon applied, as distinguished from theoretical, climatology. Practical climatology is essentially human and economic. The investigation of its life-relations is the most important subject with which climatology has to deal. (2) More attention is being paid to the variability, the frequency, and the probability of occurrence of the various climatic elements, with correspondingly less limitation to simple mean or average values. Mathematical treatment of climatic data along well-established lines, such as the use of frequency curves, and of coefficients of correlation, is becoming more general with the result that the whole body of climatological knowledge is more precise and of greater practical value. (3) In most of the recent publications on climatography the fact is recognized that, climate being average weather, no vivid and accurate picture of any climate can be gained merely from a statistical tabulation of the ordinary climatic elements. It is necessary to have also clear and interesting descriptions of the various weather types. The addition of such descriptions has resulted in a distinct gain in the more thorough understanding of climates, especially in their relations to man. For years, one of the most significant sections of *British Rainfall* has been Dr. H. R. Mill's discussion of the occurrence of heavy rainfalls in relation to the actual storm conditions which brought them. Such studies have also recently been carried out in other countries.

The outstanding general text and reference book on all aspects of climatology is the 3rd edition, in three volumes, of Dr. Julius von Hann's *Handbuch der Klimatologie*.<sup>1</sup> These volumes constitute the one indispensable handbook for all who are in any way concerned with the study of climate. The first volume (1908) deals with general climatology. The second (1910) and third (1911) volumes are devoted to climatography. In them, a summary of what is known concerning the climate of every part of the world may be found. The climatic pictures are made notably complete and accurate by means of vivid descriptions of weather types; by frequent reference to the effects of climate upon vegetation, upon crops, and upon human activities, and by well-chosen quotations from the writings of residents and of travellers who are familiar with the climates concerning which they have given accounts. Temperature, rainfall and other essential data for large numbers of stations, in many cases here worked out in detail and summarized for the first time, constitute a very valuable feature of the book. All important literature up to the date of publication of the *Handbuch* is cited. References to more recent literature will be found in the regular meteorological bibliographies.

**Classification of Climates.**—In the systematic study of the world's climates, some scheme of classification must be employed. Many such classifications have been suggested, some based on a single element of climate and others on various combinations of these elements. The late Dr. A. J. Herbertson, whose "major natural regions" are well known, made a later study of "thermal regions," using certain critical actual temperatures (68°, 50°, 32° F.) and constructing maps which show the numbers of months during which these temperatures prevail.<sup>2</sup>

The duration of these critical temperatures is of importance in the distribution and growth of vegetation, and therefore also in the life of man. A more elaborate scheme of classification has been suggested by Köppen.<sup>3</sup> This is a thorough revision of the classification proposed by him in 1900.

The critical features of the controlling factors are worked out with great accuracy and detail. A brief, simple scheme of two or three reference letters and numbers (climatic formulae) is used for the characterization of each climatic subdivision. As a framework for comparative studies of climates and of climatic controls the new map is of great value.

In studies of the general controls exercised over seasonal weather conditions, and hence also over climates in all parts of the world, the publication of the *Réseau Mondial* is of great significance.<sup>4</sup> This is a compilation of world data by 10° squares of lat. and long., based on observations at land stations averaging two for each square. Monthly and annual summaries of pressure, temperature and precipitation are included, with charts for the year 1911.

Another general publication of broad climatic interest is a study of the snow-line.<sup>5</sup> The snow-line is the resultant of climatic and topographic controls. An analysis of the observations of the snow-line is therefore an important subdivision of climatology. Nearly two-thirds of this monograph is taken up with a detailed summary and a critical examination of the data from all parts of the world, with copious references to the sources of information.

**Variations of Climate.**—The whole question of climatic variations is still under active debate, both as to the occurrence, characteristics and frequency of any such "changes," and also as to their possible causes. Dr. Ellsworth Huntington has been the most prolific writer on this problem. His investigations, which began in central Asia, have been extended over parts of western Asia, Palestine, the Libyan Desert, the southwestern United States and portions of Central America.<sup>6</sup>

From an examination of a large body of evidence—archaeological, physiographic, historical—including the rings of the giant Sequoias of California, the conclusion is drawn that from the beginnings of human history a gradual change from moister to drier climates has been going on. This process has, however, not been steadily progressive, but has taken place in a more or less irregular pulsatory fashion, drier and moister epochs alternating without definite periodicity as subordinate irregularities on the general curves of desiccation. The major fluctuations are believed by Huntington to have been essentially synchronous, and of the same general character under similar geographic conditions, in central and western Asia, in the Mediterranean area, and in North America. These pulsations are further believed to have been potent factors in bringing about certain great historical migrations and events, such as, e.g., the decline of Persia, the barbaric invasions, the decay of Rome, the rise and fall of Central-American civilization, etc.

While much evidence in favour of changes of climate in historic times has been brought forward, the opinion is quite widely held that a good deal of this is not wholly trustworthy. Much of it is so distinctly contradictory that in certain cases nothing less than a complete deadlock exists. Further, it is held by a considerable number of meteorologists that much of the evidence seems to have been interpreted without due consideration of controls other than climatic fluctuations. In cases where careful examination of the evidence has been made by experts in archaeology, botany, geology and history, there has usually been hesitation in ascribing the facts solely, or often even partly, to fluctuations in climate.

There have been several critical studies of the evidence concerning fluctuations in climate within historical times, such as those by J. W. Gregory,<sup>7</sup> Hildebrandsson<sup>8</sup> and Berg.<sup>9</sup> It seems, at the present time, to be the general consensus of the most expert meteorological judgment that there is not as yet sufficient unimpeachable evidence to justify a belief in any progressive change of climate within historic times. That there are certain fluctuations in the values of the climatic elements is, however, a well-established fact. The so-called Brückner period, averaging about 35 years in length, is generally recognized. No definite or universally accepted conclusion has yet been reached regarding the existence of other longer periods. A period of about 11 years in temperature, rainfall, and certain other meteorological phenomena has been made out by several investigators. On the whole, the variations in the values of these elements have appeared to be very slight, and the results are often debatable, if not contradictory. Köppen has greatly extended his investigations of sunspot controls over temperatures, begun some

<sup>1</sup> *Réseau Mondial*, 1911, Tables and Charts; 1912, 1913, Tables without charts, Meteorological Office, London.

<sup>2</sup> Viktor Paschinger, "Die Schneegrenze in verschiedenen Klimaten," *Ergänzungsheft*, No. 173, *Pet. Mit.*, 1912.

<sup>3</sup> Ellsworth Huntington, *Palestine and its Transformation*, 1911; "The Climatic Factor as Illustrated in Arid America," with chapters by Charles Schuchert, Andrew E. Douglass and Charles J. Kullmer, *Carnegie Inst. Publ.* No. 192, Washington, D.C., 1914. (Also numerous other articles.)

<sup>4</sup> J. W. Gregory, "Is the Earth Drying Up?" *Geog. Journ.*, vol. viii, 1914, pp. 148–172; 293–318.

<sup>5</sup> H. H. Hildebrandsson, "Sur le Présumé Changement du Climat Européen et Temps Historique," *Mém. Acad. Régies. Sociétés Scientifiques*, Ser. IV, vol. IV, No. 5, Uppsala, 1915.

<sup>6</sup> L. Berg, "Das Problem der Klimavariation in geschichtlicher Zeit," *Geog. Abhandl.*, vol. x, No. 2, Leipzig, 1914.

<sup>1</sup> J. von Hann, *Handbuch der Klimatologie*, 3rd ed., Stuttgart, vol. I, 1908; vol. II, 1910; vol. III, 1911.

<sup>2</sup> A. J. Herbertson, "The Thermal Regions of the Globe," *Geog. Journ.*, vol. xi, 1912, pp. 518–532.

<sup>3</sup> W. Köppen, "Klassifikation der Klimate nach Temperatur, Niederschlag und Jahresverlauf," *Pet. Mit.*, vol. Ixv, 1918, pp. 193–203, 243–248.



30 years ago, and has found that the 11-year periodicity appears to be somewhat less marked but more regular than he at first thought it to be.<sup>1</sup> The increase of temperature within the tropics at times of sunspot minima is about 1° F. higher than in years of sunspot maxima, and becomes less and less apparent outside the tropics. The general conclusions reached by Dr. Gilbert T. Walker do not appear to indicate any marked influence of variations in sunspot activity upon atmospheric conditions.<sup>2</sup> The correlation coefficient in the case of rainfall, e.g., is not, in general, shown to be much larger than would result from chance.

A. E. Douglass has for some 20 years been studying the evidence of climatic fluctuations given by tree rings in California and elsewhere. Some of his conclusions have been used by Huntington and others in their investigation of climatic fluctuations. In a recent volume, which also summarizes his earlier work, Douglass indicates that a close relation exists between the thickness of tree-rings and climatic conditions; sees an agreement between the tree-ring records and the results of meteorological observations during recent years, and finds evidence of periodicity, over large areas, in agreement with the sunspot cycle or multiples of it.<sup>3</sup> There is not as yet any agreement as to the causes of such climatic fluctuations. Very small irregular variations in the intensity of solar radiation are known to exist. There is also the sunspot period, and longer periods may later be established. A distinct inclination at present exists among meteorologists to seek the cause of climatic variations in changes in the general atmospheric circulation resulting from fluctuations in the sun's activity. There has been much discussion, but there is no unanimity of opinion, as to just how such variations in the amount of solar radiation will affect conditions on the earth's surface. A highly complex train of effects must obviously result, in which temperature, pressure, evaporation, cloudiness, and rainfall are all concerned, and in which readjustments in the general circulation of the atmosphere play an important part. The varying strength of the atmospheric and oceanic circulations and the resulting effects upon the development and location of the great "centres of action," and of the wind and rain belts, seem to many writers competent to account for any climatic variations which may have taken place in historical times. Thus, in one of the outstanding publications of the past decade, Helland-Hansen and Nansen, in their study of North Atlantic temperatures, conclude that variations in the supply of solar energy, acting through the atmospheric circulation, are the initial cause of temperature changes on the earth's surface.<sup>4</sup>

So far as the effect of a variation of short period like that of the sunspots is concerned, it seems highly probable that the effects are so many, so complex, and so mutually interdependent, that the periodic cause undergoes its next change before its effects are everywhere fully established. This point is emphasized by C. E. P. Brooks in a significant study of the secular variations in climate.<sup>5</sup> The sunspot period being so short, the "repercussions" do not "die down sufficiently to allow a clear vision of the relation between the solar cause and the terrestrial effect." By means of a new method of analyzing meteorological data with reference to secular variation, it appears that opposite kinds of changes in temperature, pressure and rainfall are taking place in different parts of the world in relation to a long period of sunspot numbers which shows a general decline since 1870.

The effect of volcanic dust veils in diminishing atmospheric transparency and thus affecting terrestrial temperatures has been brought forward by several writers as a possible contributing cause in climatic variations, in historical and in geological time.<sup>6</sup>

So far as changes of climate during the geological past are concerned, there has been a decided tendency towards seeking an explanation in factors which are recognized as being effectively at work in determining present-day climates, and a lessened appeal to purely astronomical causes, which in the past were most widely advocated.

The time has clearly not yet come when a general agreement is to be expected on a subject as highly complex as that of climatic

fluctuations. The facts which demand explanation are not yet sufficiently well determined or correlated, and the processes which are at work are still too imperfectly understood.

**Local Climatology.**—Two countries, the United States and Australia, stand out by reason of the progress which has been made, during the past decade, in the scientific investigation of their climates. Mention is here made only of general studies dealing with these areas as a whole. In the United States, the preparation of a section on climate for a new "Atlas of American Agriculture" marks an important advance in the accurate charting and discussion of many of the essential features of the climatic conditions of this large area. This atlas will, for many years to come, be the standard authority on all the subjects with which it deals. At the beginning of 1921 only one part of the climatic section, that on frost, had been issued in its final form. Advance publication had, however, been made of the new maps of mean annual,<sup>7</sup> monthly and seasonal rainfall<sup>8</sup> and of the new maps of sunshine.<sup>9</sup>

The new rainfall maps are based on the records from about 3,600 stations, all covering or reduced to the uniform period of 20 years (1895-1914). The base maps show the main features of the topography, reasonable account of which is taken in locating the isohyets. In the new series of rainfall maps the same basic period is used. Many details of rainfall and sunshine are further set forth by means of special diagrams and graphs. The whole subject of frost has been presented with a detail not hitherto attained in any other area of equal size in the world.<sup>10</sup> The average dates of first and last killing frost are charted (20-year period, 1895-1914), as well as the variations in the dates of spring and autumn frosts; the length of the growing season, etc.

Two new maps of average annual snowfall of the United States have been prepared. The first of these is based on observations made at about 2,000 stations during the 15 winters from 1895 to 1910.<sup>11</sup> In earlier maps, the observations came mostly from near sea-level, and hence the heavy snowfalls on the mountains were not indicated. On this new map, observations made at higher altitudes were also used and topographic effects were taken account of. A later map bears the date 1919.<sup>12</sup> This was prepared from all available records in the western mountains, and from the complete records E. of the Rockies for the period 1895 to 1914, and revised somewhat in order to bring it into conformity with certain obvious topographic influences. The first-named map brings out more clearly the heavier snowfalls on the mountains; the second adheres more rigidly to the actual observations. Investigations of relative humidities and of vapour pressures, and of the wind records for the 20-year period 1891 to 1910, have added to the more accurate knowledge of United States climates.<sup>13</sup>

The United States Weather Bureau has done useful work in summarizing the essential climatological data of the country by sections.<sup>14</sup> This publication includes the information usually desired regarding the climates of different parts of the country, brought together in convenient form for ready reference.

Australia is the second large area a knowledge of whose climatology has advanced very rapidly in the past decade. The Australian Commonwealth Bureau of Meteorology has issued an unusually valuable series of reports, dealing especially with rainfall, but also presenting many other essential facts concerning the general climatic characteristics of the country. These studies are notable because of their clear and concise method of treatment, and the emphasis which is laid on the practical economic aspects of the subject. A report on the climate and weather of Australia is one of the best available discussions of the meteorological and climatic conditions of any part of the globe.<sup>15</sup> Australian weather and climate have been discussed in publications by Dr. Griffith Taylor.<sup>16</sup>

<sup>7</sup>R. de C. Ward, "Mean Annual Rainfall of the United States, with Notes on the New Chart of Average Annual Precipitation from the 'Atlas of American Agriculture,'" *Mo. Weather Rev.* (Washington, D.C.), vol. xiv, 1917, pp. 338-345.

<sup>8</sup>J. B. Kincer, "The Seasonal Distribution of Precipitation and Its Frequency in the U. S.," *ibid.*, vol. xviii, 1919, pp. 624-631.

<sup>9</sup>*Idem.*, "Sunshine in the U. S.," *ibid.*, vol. xviii, 1920, pp. 12-17.

<sup>10</sup>W. G. Reed, "Frost and the Growing Season," *Atlas of American Agriculture*, pt. ii, *Climate*, Sec. I, Washington, D.C., 1918.

<sup>11</sup>Charles E. P. Brooks, "The Snowfall of the United States," *G. J. Met. Soc.*, vol. xxxix, 1913, pp. 81-84.

<sup>12</sup>*Mo. Weather Rev.*, vol. xvi, 1919, Chart 151.

<sup>13</sup>P. C. Day, "Relative Humidities and Vapor Pressures over the United States, including a Discussion of Data from Self-Recording Hygrometers," *Mo. Weather Rev.*, *Suppl. No. 6*, Washington, D.C., 1917; "The Winds of the United States and Their Economic Uses," *Yearbook*, Dept. of Agric. for 1911, Washington, D.C., 1912, pp. 337-350.

<sup>14</sup>Summaries of Climatological Data by Sections," *Bulletin U. S. Weather Bureau*, Washington, D.C., 1912 (and later).

<sup>15</sup>H. A. Hunt, G. Taylor and E. T. Quayle, "The Climate and Weather of Australia," *Common. Bur. of Met.*, 1913.

<sup>16</sup>See, e.g., Griffith Taylor, "The Australian Environment, especially as Controlled by Rainfall," *Federal Advisory Council of Science and Industry*, Mem. No. 1, Melbourne, 1918.

<sup>1</sup>W. Köppen, "Lufttemperatur, Sonnenflecken und Vulkan- ausbrüche," *Met. Zeitschr.*, vol. xxxi, 1914, pp. 305-328.

<sup>2</sup>G. T. Walker, "Sunspots and Temperatures," *Mem. Indian Met. Dept.*, vol. xxi, Pt. II, Simla, 1915, pp. 61-90; "Sunspots and Rainfall," *ibid.*, vol. xxi, Pt. I, 1915, pp. 17-59.

<sup>3</sup>A. E. Douglass, "Climatic Cycles and Tree Growth: A Study of the Annual Rings of Trees in Relation to Climate and Solar Activity," *Carnegie Inst. Publ. No. 289*, Washington, D.C., 1919.

<sup>4</sup>B. Helland-Hansen and F. Nansen, "Temperature Variations in the North Atlantic Ocean and in the Atmosphere: Introductory Studies on the Cause of Climatological Variations," *Smithsonian Misc. Coll.*, vol. lxx, No. 4, Publ. 2537, Washington, D.C., 1920.

<sup>5</sup>C. E. P. Brooks, "The Secular Variation of Climate," *Geog. Rev.*, vol. xi, 1921, pp. 120-35.

<sup>6</sup>See, e.g., the following:—C. G. Abbot and F. E. Fowle, "Volcanoes and Climate," *Smithsonian Misc. Coll.*, vol. lxx, No. 29, 1913; Charles Schuchert, "Climates of Geologic Times," *Carnegie Inst. Publ. No. 192*, Washington, D.C., 1914; W. J. Humphreys, *Physics of the Air*, Philadelphia, 1920, pt. iv.

The main thesis of these monographs is the climatic limitation and control of agriculture and of stock-raising. The results are likely to be of practical value in the future development of Australia. The extreme importance of rainfall is emphasized, not only of the annual amounts but also of the season at which the rain falls, and of its reliability.

While the meteorology of the Arctic has made little progress during the last ten years, the Antarctic has been visited by a large number of expeditions, most of the results of whose scientific work, as well as some of the results of work done prior to 1910, have been published in the last decade. These discussions include those relating to the British expeditions of 1901-4, 1910-3 and 1914-7; the Australian expedition of 1911-4; the Norwegian of 1910-2; the German of 1911-2. Meteorological observations are now available, for complete years, made at fixed land stations; on board vessels drifting slowly in the ice on sledge journeys, and from the upper air by means of kites and balloons. The available material is, however, still too scattered and incomplete to give an accurate and satisfactory picture of Antarctic climate. Most of the discussions have concerned the physical problems of Antarctic meteorology rather than the larger facts and controls of climate. The mean temperatures of the higher southern latitudes have been determined by Meinardus as follows:—

S. Lat.	60°	70°	80°	90°
Jan. . . . .	37.0° F.	29.7° F.	24.3° F.	21.2° F.
July . . . . .	12.9°	-7.6°	-19.2°	-27.9°
Year . . . . .	25.7°	9.0°	-5.1°	-13.0°

The fact that these latitudes are colder in the Antarctic than in the Arctic is now abundantly confirmed. The Antarctic obviously has a distinctly continental climate, but with a cold summer. The lowest mean annual temperature hitherto recorded was observed at Framheim, the nearest fixed point to the South Pole at which observations have been made (-11.2° F.). Much light has been thrown on the cyclonic phenomena of the southern oceans through the inclusion, in both British and German publications, of a considerable series of daily synchronous weather maps.

**Climate and Agriculture.**—Recent studies of the larger controls of climate over crop distribution, and of weather factors which most affect the critical periods of growth and of yield of field and garden crops, have brought out much information which will prove of importance in the advance of agricultural climatology. The geographic origin of the world's food supply and of other essential agricultural products, and of the climatic and other factors which control the present distribution of the world's crops and live stock, have been discussed.

In this atlas, the essential climatic controls in the case of the important crops of the world are briefly stated. Another outstanding publication, also of wide interest, deals with cotton.<sup>1</sup> The climates of all the cotton areas are discussed, detailed consideration being given to the United States. The facts here given are of practical value in the selection of the most favourable climates for future cotton-growing. A very practical application of scientific research to agricultural practice is seen in the establishment, for the United States, of a "bioclimatic law."<sup>2</sup> According to this law, there is a country-wide average rate of variation in the time of occurrence of the regular periodic events in plants and animals, depending on altitude, latitude and longitude. The rate is four days for each 1° of long., 5° of lat. and 400 ft. of altitude.

**Forests and Climate.**—But little important work has lately been done on forest influences upon climate. So far as this goes, it points to nothing more than inconsiderable effects. For example, in India the latest indications are that while forests tend to increase rainfall, the effects are by no means marked.<sup>3</sup>

In the United States, an investigation of the forests of the S.W. shows that their influence is essentially similar to that previously indicated by European observations.<sup>4</sup> In other words, forests have a little higher mean annual temperature than the open; somewhat modify the extreme of temperature; reduce wind velocity and decrease evaporation within the forest, but have only a negligible effect upon precipitation except in connexion with the distribution and disposal of snow and rain.

<sup>1</sup> V. C. Finch and O. E. Baker, "Geography of the World's Agriculture." U.S. Dept. of Agriculture, Office of Farm Management, Washington, D.C., 1917. Atlas and text.

<sup>2</sup> O. C. Stine and O. E. Baker, "Cotton," *Atlas of American Agriculture*, pt. v., Sec. A, U.S. Dept. of Agriculture, Office of Farm Management, Washington, D.C., 1918.

<sup>3</sup> A. D. Hopkins, "Periodical Events and Natural Law as Guides to Agricultural Research," *Mo. Weather Rev., Suppl. No. 9*, Washington, D.C., 1918. See also O. E. Baker, C. F. Brooks and R. G. Hainsworth, "A Graphic Summary of Seasonal Work on Farm Crops," *Yearbook, U.S. Dept. of Agric.*, 1917, pp. 537-589.

<sup>4</sup> M. Hill, "Notes on an Enquiry by the Government of India into the Relation between Atmospheric and Soil Moisture in India," *Forest Bull. No. 33*, Calcutta, 1916.

<sup>5</sup> G. A. Pearson, "A Meteorological Study of Parks and Timbered Areas in the Western Yellow-Pine Forest of Arizona and New Mexico," *Mo. Weather Rev.*, vol. xii., 1913, pp. 1615-1629.

**Physiological Climatology.**—It has for some time been recognized that conditions which are best for human beings are moderately cool and moderately moist air, in motion, together with a reasonable variability of temperature. Numerous suggestions have been made regarding the instrumental measurement of the climatic elements most essential in this problem. In general, the tendency has been to use already available data on air temperature and relative humidity, or to employ ordinary wet and dry bulb thermometer readings. Dr. Leonard Hill has devised a so-called "Kata-thermometer" which indicates, by the rate of cooling of wet and dry bulb thermometers heated to about the surface temperature of the human body, the combined effect of temperature, humidity, wind, evaporation, etc.<sup>1</sup> Several investigators have sought to determine, in actual numerical values, the most favourable atmospheric conditions for man. Dr. Griffith Taylor, using wet bulb temperatures and relative humidities, has worked out the criteria of a suitable climate for Anglo-Saxons in the tropics.<sup>2</sup> The "type white climograph" for which this suggests as representing ideal conditions shows, for summer, a wet bulb reading of 62° F. and relative humidity of 68.5% for winter, 37° F. and 81%. Using statistics of the efficiency of factory operatives, students and others in the eastern United States, Huntington has determined what he calls the "optimum" temperatures for man's greatest efficiency.<sup>3</sup>

These are outdoor temperatures of 60°-65° F. for maximum physical efficiency and 40° F. for maximum mental efficiency. There is also found to be a beneficial stimulating effect in a certain moderate degree of temperature variability, which is associated with storm controls. The different parts of the world are graded according to their approximation to such a climate, and the civilizations of those areas are also graded. A close agreement is found between the results. The conclusion is reached that a certain special combination of climatic conditions prevails today where high civilization is found; and that past climatic fluctuations which brought a similar type of climate were associated with corresponding periods of high civilizations.

Criticism of these far-reaching conclusions has been based on the insufficiency of the data of human efficiency upon which the study rests; the somewhat arbitrary combination of the climatic factors, with disregard of the element of humidity, and a lack of any general agreement as to the facts concerning the distribution of civilization and the occurrence of special climatic types in past times.

(R. DE C. W.)

**CLODD, EDWARD** (1840— ), English anthropologist, was born at Margate July 1 1840, and educated at Aldeburgh grammar school. At the age of 15 he became a clerk and seven years later entered the London Joint Stock Bank, Ltd., where he rose by 1872 to the post of secretary. He interested himself in questions of the descent of man and the origins of religion, and early became known as a rationalist thinker.

Amongst his writings are: *The Childhood of the World* (1872); *The Childhood of Religions* (1875); *Myths and Dreams* (1885); *Story of Primitive Man* (1895); *Animism or the Seed of Religion* (1906); *Magic in Names* (1920), and biographies of Huxley and Grant Allen, as well as a volume of *Memories* (1916) and a discussion of the possibility of human survival after death, entitled *The Question* (1917).

**CLYNES, JOHN ROBERT** (1869— ), English politician, was born at Oldham March 27 1869 of working-class parents, and worked himself as an artisan for many years. He was active in the trade-union movement, and eventually became president of the National Union of General Workers, and chairman of the executive council. He came into Parliament as Labour member for N.-E. Manchester in 1906, when the Labour party were returned for the first time in numerical force—over 50 in all. It was not, however, until the World War that he attracted public attention. He protested, in Feb. 1915, on behalf of his party against the rise in prices, which he attributed mainly to contractors and dealers exploiting the needs of the people. His interest in this subject made it natural that he should be selected—as himself a working man—to be parliamentary secretary

<sup>1</sup> Leonard Hill, "Atmospheric Conditions which affect Health," *G. J. Met. Soc.*, vol. xiv., 1919, pp. 189-206; "The Science of Ventilation and Open-Air Treatment," *Medical Res. Council, Spec. Report Series*, No. 52, London, 1920, p. 295.

<sup>2</sup> Griffith Taylor, "The Control of Settlement by Humidity and Temperature (with Special Reference to Australia and the Empire): An Introduction to Comparative Climatology," *Commonwealth Bur. of Met., Bull. 14*, Melbourne, 1916.

<sup>3</sup> Ellsworth Huntington, *Civilization and Climate*, New Haven, Conn., 1915. (This vol. also summarizes much of the author's earlier work, including that on historical changes of climate.) *World Power and Evolution*, New Haven, Conn., 1919.

under Lord Rhondda soon after the latter accepted the position of controller of food. In the arduous and successful work of that office he took his full share. He became president of a consumers' food council in Dec. 1917, so that the office might keep in regular touch with the needs of the public. When Lord Rhondda died, in June 1918, he succeeded him to the general satisfaction. He gave special encouragement to the creation of national kitchens, the number of which had grown by the end of Aug. to over 600, and he set up in Sept. inside the Ministry a food council to consider questions of policy, and to cooperate with other bodies dealing with the food problems of the Allies. In consequence of the decision of the Labour party to terminate its support of the Coalition Government he resigned office in Nov. just before the general election. At the beginning of the session of 1919 he was elected vice-chairman of the party, and he took a considerable share in debate, speaking with a moderation and appreciation of the standpoint of other classes not always manifested by Labour members. At the trades union congress in Sept. he made a strong speech against the policy of "direct action," pointing out that Labour could capture the political machine if working men were sufficiently united and sufficiently active, but that threats would only throw back their cause and set all other classes against them. But a year later he acquiesced in the establishment of a Labour council of action, and in the threat of a general strike in case of any military or naval intervention against the Soviet Government of Russia. In 1921 he was chosen chairman of the parliamentary Labour party.

**COAL** (see 6.575).—In 1910 the world output of coal, including lignite and anthracite, may be estimated to have been 1,160 million metric tons, and it reached 1,342 million tons in 1913. The rapid growth in the production of coal up to 1910 is indicated by the fact that in the period 1894-8 the average quantity raised each year was only 604 million tons, or about one-half the quantity raised in the year 1910. In the five years 1874-8, 285 million tons were raised each year on the average, or about one-fourth of the quantity raised in 1910.

The output of coal in 1913 was subsequently exceeded but once up to 1921, viz. in 1917, when 1,345 million tons were raised, and the dislocation in the production of coal caused by the World War is seen from the following estimates of output during the years 1910-20, prepared by the United States Geological Survey Department:—

	Estimated Quantity of Coal Raised (Million metric tons)	Percentage of 1913		Estimated Quantity of Coal Raised (Million metric tons)	Percentage of 1913
1910	1,160	86	1916	1,296	97
1911	1,189	89	1917	1,345	100
1912	1,249	93	1918	1,331	99
1913	1,342	100	1919	1,158	86
1914	1,205	90	1920	1,300	97
1915	1,196	89			

The effect of the war, however, was chiefly felt in Europe, as the following comparison of the output of coal in the years 1913 and 1920 shows:—

Continent	Output of Coal in		Increase (+) or Decrease (-) in 1920	
	1913	1920	Quantity	Percentage
	Million metric tons			
Europe	730.0	597.5	-132.5	-18.1
America: North	531.6	601.3	+69.7	+13.1
South	1.6	1.7	+ .1	+ 6.2
Asia	55.8	75.8	+ 20.0	+ 35.8
Africa	8.3	11.8	+ 3.5	+ 42.2
Australia and Oceania	15.0	11.9	- 3.1	- 20.7
World	1,342.3	1,300.0	- 42.3	- 3.2

The aggregate loss of output in Europe during the years 1914-20 was nearly equal to the quantity raised in the year 1913, or considerably more when allowance is made for the normal rate of expansion prior to the war. From the position of a continent self-contained in regard to coal supplies and able to

furnish no inconsiderable part of the requirements of the navies and merchant fleets of the world, Europe had temporarily become dependent upon outside sources of supply. In 1920 coal was obtained chiefly from North America, but small quantities from South Africa, from China, from Australia and from Spitsbergen found their way to Europe.

While the output of coal in Europe in the year 1920 diminished by nearly one-fifth when compared with that of 1913, partly owing to reductions in the hours of labour and partly to labour disputes, the number of workpeople employed at coal-mines increased in the principal countries of Europe by about one-seventh. And after the conclusion of the war the question of the "nationalization" of the coal-mines (see NATIONALIZATION) became a subject of more or less acute controversy in the chief producing countries of the world.

The immense coal resources of the world were but imperfectly realized up to 1910, and knowledge with regard to them was greatly increased as a result of the Twelfth International Geological Congress held in 1913 at Ottawa, for which a monograph on "The Coal Resources of the World" was prepared. From this the following summary is taken:—

Continent	Lignite and sub-Bituminous Coals	Bituminous Coals	Anthracite and semi-Anthracite	Total
	Million metric tons			
Europe	36,682	693,162	54,346	784,190
America: North	2,811,902	2,239,682	21,842	5,073,426
South	8.4	31,398	700	32,102
Asia	111,851	750,098	407,637	1,279,586
Africa	1,054	45,123	11,662	57,839
Australia and Oceania	36,279	133,481	659	179,419
World	2,997,763	3,902,944	496,846	7,397,553

The coal raised during the 11 years 1910-20 amounted to 13,771 million tons, or one-fifth of 1% of the estimated reserves. It should, however, be added that no deduction has been made in framing these estimates for coal which was not mineable, nor for the loss of coal in working. A large part of the coal included will be raised with great difficulty and the loss in mining will also be great.

UNITED KINGDOM

For at least half a century prior to the outbreak of war the production of coal in Great Britain increased at a substantial, if unequal, rate annually. But after the year 1913 this movement was arrested and during the three years 1918-20 the output of coal was only equal to the quantity raised in the years 1902-4. Estimated on the experience of the period 1871-1900 the output of coal in 1918-20 should have been not less than 300,000,000 statute tons per annum.

After the conclusion of the war the number of persons employed at coal-mines was greater than at any previous date, and in 1920 was 50% greater than in the year 1903. The hours of labour of those employed below ground, it is true, had been twice reduced since that year. An 8-hour shift from bank to bank (equal to more than 8½ hours per man on the average) was introduced in 1909-10, and a further reduction to 7 hours per shift was effected in July 1910. No general change was made in the hours of labour of surface workers until Jan. 1919, when a maximum 49-hour week was established. In July of the same year this was reduced to 46½ hours per week, or a total reduction of 4½ to 11½ hours per week over the whole period.

Prior to the introduction of the 8-hour shift below ground the annual rate of output was 285 tons per person employed, and the normal rate of output subsequently appears to have been some 20 to 25 tons less. In the year 1920 the output of coal per person was 191 tons, or about 200 tons, making allowance for the effect of the national strike of coal-miners in that year.

With the shrinkage in the supply of coal there had been a serious increase in its selling price. Between the years 1910 and 1914 the average selling price at the pit rose from 8s. 2d. to 10s. per ton. During the war the selling price was gradually raised, and it stood at 20s. 11d. per ton on the average in 1918. This was due partly to the increased cost of timber and stores, but

chiefly to the general upward movement in nominal wages. The average selling price of coal during the latter half of 1920 was 39s. to 40s. per ton, the average for the year being 34s. 7d. per ton.

One bright feature alone reveals itself in this picture of increasing cost and diminishing supplies of coal, in the increasing safety of the workers employed at the mines. Though the years 1910 and 1913 were both marred by mining disasters of some magnitude—that at the Senghenydd pit in Glamorganshire in the latter year being the greatest on record—there was a noticeable diminution after 1910 in the number of persons killed and injured by accidents at coal-mines.

Particulars of the quantity and value of the coal raised, the number of persons employed at coal-mines, and the numbers killed and injured by accidents during the years 1910–20, will be seen in the statement which follows:—

Year	Output of Coal			Number of Persons Employed at Coal-mines	Number of Persons Killed or Injured by Accidents*	
	Quantity (Million statute tons)	Value at Pit (Million £)	Average Value per ton (s. d.)		Killed	Injured
1910	264.4	108.4	8 2	1,032,700	1,775	159,042
1911	271.9	110.8	8 2	1,049,900	1,265	166,616
1912	260.4†	117.9	9 1	1,072,400	1,276	150,652
1913	287.4	145.5	10 2	1,110,900	1,753	177,189
1914	265.7	132.6	10 0	1,041,200*	1,219	158,362
1915	253.2	157.8	12 6	939,600	1,297	177,429
1916	256.4	200.0	15 7	984,800	1,313	(Particulars not available)
1917	248.5	207.8	16 9	1,006,300	1,370	
1918	227.7	238.9	20 11	994,300	1,411	
1919	229.8	314.1	27 4	1,176,100	1,118	117,422
1920	229.5	396.9	34 7	1,233,200	1,103	117,302

The period covered by the statement above includes the years down to 1914 during which the development of the coal resources of the country reached its zenith under the individual ownership of the mines. Early in 1912 a national strike of miners laid the pits idle for a period of six weeks and was settled by the passage of the Coal Mines (Minimum Wage) Act, 1912.

**Effects of the War.**—In Aug. 1914 war was declared, and early in 1915 the necessity for Government supervision of the production and distribution of coal became apparent. At first this was restricted to the limitation of the selling price of coal at home and of the quantity sold abroad. By the middle of 1916 the number of miners employed had fallen by nearly 14% since July 1914, the younger, stronger and the most capable amongst whom had joined the fighting forces. The loss was much greater in reality, since 282,200 men had left the mines up to the end of March and the places of some 116,000 of these men had been taken by others. By the end of the war 400,000 coal-miners had joined H.M. forces. Increasing difficulties in the supply and distribution of coal were experienced, and in order to deal with them a committee representing various Government departments, railway companies, colliery owners and coal factors and merchants was appointed in Jan. 1916. This committee co-ordinated the action of other committees of colliery owners in each coal-field. At the end of 1916 acute labour troubles in the South Wales coal-field compelled the Government to take possession of the mines in the district, and on March 1 1917 similar action was taken with regard to all coal-mines.

**Output and Management.**—Up to 1916 the rate of output in normal years was still at or above 260 tons per person employed, the total output in 1916 being 31,000,000 tons less, and the number of persons employed 126,000 less than in 1913, the year of maximum production. The average selling price of coal in 1916, whether for consumption at home or abroad, was 15s. 7d. per ton, or 53% higher than in

1913, the highest pre-war figure since records were first established in 1882. From March 1917 to the end of March 1921 the mines were under Government control and a special Department of State was created for their administration. By powers conferred upon the Board of Trade by the Mining Industry Act, 1920, this Department has since been organized on a permanent basis with a view to the better administration of the mining industry generally, and was assisted during the period of control by the central and district organization created early in 1916. In June 1917 the price of coal sold for export and for bunkering vessels was definitely brought under control and so remained until May 1919. The control of prices at home was only relinquished on March 1 1921.

As compared with the year 1916 the output of coal had fallen in 1920 by 27,000,000 tons, while the price had risen by 19s. per ton and some 248,000 additional workers had been enrolled.

The output of coal in relation to the number of persons employed at coal-mines is a convenient measure of changes which occur in the productivity of the industry, but unless allowance is made for the amount of employment available the results are liable to be misleading. Fortunately for the comparison which follows, employment at coal-mines was exceptionally good from 1913 onwards except during the latter part of the years 1914 and 1920. In 1910 and 1911 employment was moderate, and in 1912 the pits were idle for about six weeks owing to the minimum-wage dispute.

Absenteeism from work on the part of the miner amounted during the war period to about 10% of the total number of possible shifts. Of this one-half was due to sickness, injury and other unavoidable causes. The normal working time of the miner in the several districts approximates closely to 5½ days per week, including overtime. In the case of coal-getters about 5 days per week is usual.

Year	Tonnage Raised per Person Employed	Percentage of 1913	Year	Tonnage Raised per Person Employed	Percentage of 1913
1910	260	99	1917	250	95
1911	261	99	1918	228	87
1912	245	93	1919	202	77
1913	263	100	1920	191	73
1914	252	96	Average for years 1910–20		
1915	268	101	1910–20	244	93
1916	266	101	1900–9	285	108

When compared with the output of the American miner, these figures, even in years of maximum output, appear to be small. It is necessary, however, to bear in mind the relative thickness and accessibility of the coal measures from the surface in each country, the position in which they are found, the extent to which mechanical cutting is capable of adoption and the method of haulage employed below ground. In some or all of these ways the American coal-miner enjoyed considerable advantages over the British miner.

But the output rate is affected by the extent to which development work in the pits is maintained and by the opening of new and productive pits. Since the middle of the year 1914 it is probably true to say that such work has suffered considerably, though by concentrating upon the best seems a higher rate of output was achieved during the earlier years of the war.

The progressive nature of the fall in the rate of output, synchronizing as it did with successive increments of wages, seems to indicate that other causes were partly responsible—and this responsibility the management must share with the miners.

In the year 1917 the method of percentage additions to hewers' wages with corresponding additions to the wages of time-workers was abandoned in favour of flat-rate additions to the wages of workers of all classes, and, with minor exceptions, of all ages, as in the case of the war wage and Sankey wage. These flat-rate increments favoured the lowest-paid workers at the expense of the higher-paid workers, since the relationship of the wages of each class was altered. Successive additions of uniform amount had the effect of raising the minimum rates of wages to a level at which many hewers found the inducement to rest upon it greater than they could resist. In 1920 an attempt was made to restore the percentage principle in wage adjustments and greater differentiation in respect of age, but with little success.

The output of the miner, however, is influenced by good and bad management, and it is necessary to consider how the management of the mines was affected by the arrangements made during the period of control. The position with regard to profits in the coal-mining industry in South Wales prior to Dec. 1 1916 and in all other coal-fields to March 1 1917, when the mines came under control, was the same as in all other industries. The Coal Mines Control Agreement (Confirmation) Act, 1918, provided for the retention by colliery owners of the profits earned when they did not exceed the amount of the pre-war standard fixed for excess-profits duty. Where this amount was exceeded, one-fourth was retained and the balance was collected as coal-mines excess payments. From the sums so collected the pre-war profit of the collieries earning less than the pre-war standard of profit was made good, but the full pre-war standard

\* Not including 2,268,000 tons of refuse raised with coal and similarly in subsequent years. For years previous to 1912 such refuse was included.

† The number of persons employed during Jan. to July 1914 was 1,116,600. On the last pay day in Dec. the corresponding number was 968,800, approximately, and the number taken represents the mean of these numbers.

‡ Including deaths and injuries through accidents reported at all mines of coal, stratified ironstone, shale and fireclay.

of profit was permitted only in cases where output was fully maintained and the business was efficiently conducted.

This arrangement was amended retrospectively as from April 1 1919 by the Coal Mines (Emergency) Act, 1920, by which the industry was regarded as a single concern. Where the pre-war standard of profit was exceeded, nine-tenths of the excess profit was paid over to the State, while of the remaining tenth, after the deduction of excess-profits duty, one-half was distributed on a tonnage basis to all collieries and one-half was shared by the collieries contributing the excess profits. The net amount of excess profit retained by the industry was 4% of the gross profits earned.

Owing to the serious fall in the price of coal sold abroad early in 1921 a further variation was made in the existing arrangement by which profits in excess of nine-tenths of the pre-war standard were required to be surrendered and shared as from Jan. 1 1921. On March 31 1921 the period of control was terminated.

The general effect of these intricate arrangements was to curtail the excess profits of colliery owners much more severely than in other industries, and it is difficult to resist the conclusion that the decline in the rate of output after 1916 was largely due to the stifling of incentive in both the management and the workers.

The distribution of the revenue of the industry in 1913, 1918 and 1920 is shown by the following comparisons, the amounts being calculated on the basis of the tonnage of coal disposed of:—

	1913 (Jan. 10 Dec.)	1918 (July to Sept.)	1920 (July to Sept.)
<b>Cost of Production:</b>			
Wages . . . . .	6 4	15 7½	26 3
Stores and Timber . . . . .		3 6½	5 5½
Other Costs . . . . .	1 10½	1 4½	2 6½
Royalties . . . . .	5½	7½	7½
Total Cost . . . . .	8 7½	21 1½	34 10½
Proceeds from Sales . . . . .	10 7½	24 10	39 7
Balance of Proceeds . . . . .	1 6	3 8½	4 10½*
<b>Coal Raised per Person Em- ployed per Quarter . . . . .</b>	65½ tons (average)	58½ tons	50 tons
<b>Earnings per Person Em- ployed per Quarter . . . . .</b>	£21 (average)	£42	£59

Though not strictly comparable owing to minor differences in the method of computation, these figures show the progressive increase in the cost of production and the disparity in the rates of output and earnings of the workers. In 1913 rather more than one ton of coal was raised on the average for each man shift worked, the average earnings per shift being about 6s. 6d. In the third quarter of 1920 the average earnings were nearly 17s. per shift, while not more than 16 cwt. of coal were raised.

Against the balance of proceeds has to be set the cost of depreciation, interest on loans and the profits in each year, and in 1918 and 1920 excess-profits duty and the cost of control. Various estimates have been made of the amount of capital invested in the coal-mining industry. Owing to the combination of coke, iron and steel-making with the production of coal, the results are necessarily approximate, but for the years prior to the outbreak of the war may be taken at £130,000,000, not including the capital invested in coke ovens and by-product plant. The capital of the industry in 1921 was more than £50,000,000 greater.

During the years 1909 to 1914 the average profits earned, apart from royalties, were nearly 10% per annum of the capital invested, making no deduction for profits carried to reserve and capitalized. In the three years following profits, exclusive of royalties and excess-profits duty, amounted to 17% per annum, and during the years 1917 to 1921, to 15½% per annum. Making allowance for profits reinvested in the industry during the seven years 1914-21, the amount available for dividends, partners' drawings, and income tax represented a possible yield of 11½% per annum on the capital employed in the industry.

During the quarter ended Sept. 1920 the average price of coal sold at home was just over 33s. per ton at the pit, that of coal shipped as foreign bunkers 67s. 3d. per ton and of coal exported 76s. 8d. per ton. The surplus revenue on the bunker and export coal provided the fund from which the profits of the industry were paid. During the winter of 1919-20 a special rebate of 10s. per ton was granted on coal sold for domestic use, including coal converted to gas and electricity for domestic heat and light. The average selling price at this period did not greatly exceed 19s. per ton at the pit.

The home consumer, it will be seen, enjoyed considerable advantages in regard to the price paid for coal, but the protection of the home consumer extended to the quantities supplied, which were maintained throughout the war and subsequently at the same level, approximately, as before the war.

\* Including the sum of 13d. per ton disposed of commercially, derived from the proceeds of miners' coal supplied at special prices.

The quantities of coal shipped abroad during the years 1910-2 and the quantities available in each year for consumption at home are shown below:—

	Coal Exported †	Coal Shipped as Foreign Bunkers	Coal Available for Home Consumption
	Million statute tons	statute tons	tons
1910	65.0	19.5	179.9
1911	67.8	19.3	184.8
1912	67.5	18.3	174.6
1913	77.3	21.0	189.1
1914	62.5	18.3	184.7
1915	46.3	13.6	183.3
1916	42.0	13.0	201.4
1917	38.5	10.2	199.8
1918	34.6	8.7	184.4
1919	39.3	12.0	178.5
1920	29.7	13.9	185.9

As compared with the year 1913 the reduction in output amounted in 1920 to 58 million tons which fell almost entirely on supplies for shipment abroad, the home supply suffering to the extent of little more than three million tons. The bulk of the coal shipped abroad, apart from that shipped as bunkers, was supplied to Europe and the countries lying round the Mediterranean Sea as is shown below:—

Destination	1913	1920
	tons	tons
Europe and Mediterranean Countries	63,481,000	22,791,000
Africa and Asia (exclusive of Mediterranean Countries)	2,678,000	932,000
South America	6,939,000	557,000
North and Central America	160,000	652,000
Other Destinations	142,000	
Total: (Coal Cargoes)	73,400,000	24,932,000
Quantity Shipped as Bunkers by Vessels Engaged in the Foreign Trade	21,032,000	13,923,000
Coke and Manufactured Fuel Exported in Terms of Coal	3,906,000	4,821,000
Total Shipments	98,338,000	43,676,000

The chief uses to which the home supply is put will be seen from the following comparison of the distribution of coal in 1913 and 1919:—

Use	1913	1919
	Million statute tons	tons
Domestic	35.0	36.5
Railways	13.6	13.5
Steamships (Coasting)	2.4	1.3
Gas Works	17.0	17.8
Colliery Engines and Miners' Fuel	23.0	22.5
Blast Furnaces	21.2	13.7
Other Industries and Commercial Uses	76.9	71.2
Total	189.1	178.5

The reduction of 10.6 million tons in the consumption of coal between 1913 and 1919 was almost entirely accounted for by the lessened industrial demand for coal upon the cessation of war.

**Plant and Equipment.**—While the importance of an adequate supply of coal assured a certain measure of priority during the war to the demands made for colliery plant and equipment, it was inevitable that some falling off should be observed in the provision and perfection of plant and equipment as compared with the year immediately preceding the war. The importance of this arises from the fact that the coal used at colliery engines amounts to about one-tenth of the consumption at home.

In the year 1907 the capacity of the engines in use at coal-mines (including the stratified iron-mines of the Cleveland district) was 2,293,978 H.P., of which some 7% was used for the generation of electric power and light. The capacity of the motors then installed is known, but since the year 1912 the capacity of electrical apparatus in use at coal-mines has doubled.

There were 1,959 mechanical coal-cutters installed at mines in 1910 and nearly 16 million tons of mineral were cut by these machines. In 1920 the number of machines had increased to 5,073 with an output of 30 million tons of mineral. The chain-drive machine has shown the greatest relative increase in the interval, though percussive machines show the greatest absolute increase.

The tenacity with which the industry clings to past traditions is nowhere seen more clearly perhaps than in the maintenance of horses and ponies for haulage work below ground. In 1920 there were 67,748 horses and ponies so employed at coal-mines, or only 3,778 less than in 1912. The number of mechanical conveyors employed at the coal face increased from 274 in 1910 to 823 in 1920.

† Including the coal equivalent of coke and manufactured fuel exported.

While the tallow dip used as an illuminant below ground is not yet extinct, the safety lamp is all but supreme. In 1910 there were 705,482 of these in use, including 2,055 electric portable lamps. The total number of safety lamps in use in 1919 was 833,880 and of these 197,722 were electric lamps. In 1920 the number of electric lamps in use had risen to 245,900. The caution which necessarily marks the extended use of electricity below ground for lighting and power is less observable in the increased use of portable electric lamps, but there are limits to the universal use of electric lamps in mines where the risk of finding gas is great.

**Accidents, Safety Measures and Health.**—The usefulness of governmental control of industry is exemplified in an exceptional degree by the notable reduction which has taken place in the number of fatalities and injuries to the workers at coal-mines. In the years 1851-60, the earliest for which complete information is available, the number of deaths from accidents at coal-mines was 4.07 per 1,000 persons employed per annum, while during the years 1910-20 the number reported was only 1.27 per 1,000 persons per annum. In the United States 3.40 deaths per 1,000 persons employed occurred through accidents at coal-mines during the years 1910-9, or nearly three times as many as in the United Kingdom.

The period from 1910 opened with a series of disasters, two of which were exceptionally severe. The principal disasters occurring in the years 1910-20 include the following:—

	Name and Situation of Pit	Number of Lives Lost
1910	Wellington Pit, Whitehaven Colliery, Cumberland	136
1910	No. 3 Bank Pit, Hulton Colliery, Lancashire (Pretoria Pit)	344
1912	Cadeby Main Colliery, Conisborough, Yorkshire	88
1913	Senghenydd Colliery, near Caerphilly, Glamorgan	440
1918	Minnie Pit, Podmore Hall Colliery, Newcastle, Staffs.	155

The Royal Commission on Mines, which was appointed in 1906, dealt exhaustively with the health and safety of miners and the administration of the Mines Act. The chief recommendations of the Commission related to the augmentation of the staff of mines inspectors; alteration of the system of inspection and the appointment of practical miners on the inspectorate; fixing of responsibility upon owners and their agents; qualification by examination or experience of firemen and deputies; greater regularity and frequency of inspections; a higher standard of ventilation; investigation of the methods of minimizing the quantity of coal-dust in mines; precautions to be adopted in shot-firing; rules for the proper testing and use of safety lamps; effective timbering of mines; regular medical inspection of winding engines; organization of rescue stations and the provision of rescue appliances; provision for pit-head baths and dressing-rooms; and the accurate keeping of colliery plans. Practical effect has now been given to the majority of these recommendations, which were embodied in the Coal Mines Act, 1911. This Act consolidated and codified the law in regard to safety at coal-mines and was at the time of its promulgation the most detailed of any form of Government regulation of industry.

The most notable additions made in the decade to the provisions for the safety of mine workers were the organization of measures for effecting rescues from accidents below ground due to gas, fire or explosions, which was brought into operation in 1910, and the introduction of preventive measures against explosions of coal-dust.

Fairly complete arrangements had by 1921 been made for the organization and training of rescue brigades and the provision of appliances at mines. At the end of 1919 there were 49 central rescue stations each with its trained rescue brigade, a minimum provision of breathing apparatus and other appliances, and able to supply the oxygen or liquid gas required for the use of the former. These stations provided the rescue service for 610 mines, or groups of mines, and there were in addition 553 mines or mine groups at which 1,263 rescue brigades were maintained with a suitable proportion of breathing apparatus and appliances. These brigades are recruited from the mine workers and each consists of five or six men who are required to qualify by prescribed courses of training and practice, to be familiar with mine plans, the use and construction of breathing apparatus and skilled in the detection of poisonous or inflammable gases.

Following upon the recommendation made by the Royal Commission on Mines, experimental work with regard to the origin of coal-dust explosions in mines and the measures to be taken for their prevention was carried out at Althofts in Yorkshire by the Mining Association of Great Britain, the mine-owners' organization. In 1911 the Home Secretary appointed a committee of experts to control and direct an experimental inquiry at Eskmeale, near Barrow-in-Furness, in continuation of this work.

The main conclusions arrived at as a result of these experiments were that by stow-dusting or by watering mines, or by a combination of both methods, the risk from explosions would be very greatly

minimized, if not prevented, and a preliminary communication in this sense was sent to colliery owners in 1912. Owing to the war, statutory effect was not given to the recommendations of the Home Office Committee until July 1920.

The number of deaths and injuries to persons caused by accidents at all mines of coal, stratified ironstone, shale and fireclay in the years 1910, 1913 and 1920, distinguishing the place and cause of injury or death, is shown below. Injuries involving an absence from work for less than seven days are not recorded:—

Cause of Death or Injury	1910	1913	1920
NUMBER OF PERSONS KILLED			
<i>Below ground</i>			
Explosions of firedamp . . . . .	501	462	26
Falls of ground . . . . .	636	620	544
Shaft accidents . . . . .	89	98	40
Haulage accidents . . . . .	286	251	237
Other accidents . . . . .	110	149	118
<b>Total: Below ground . . . . .</b>	<b>1,622</b>	<b>1,580</b>	<b>965</b>
<i>Surface</i>			
On railways, sidings or tramways . . . . .	71	81	54
Elsewhere on surface . . . . .	82	92	84
<b>Total: Surface . . . . .</b>	<b>153</b>	<b>173</b>	<b>138</b>
<b>Total: Below and above ground . . . . .</b>	<b>1,775</b>	<b>1,753</b>	<b>1,103</b>
Per 1,000 persons employed	1.69	1.55	0.88
Excluding deaths due to explosions of firedamp . . . . .	1.10	1.04	0.85
NUMBER OF PERSONS INJURED			
<i>Below ground</i>			
Explosions of firedamp . . . . .	167	131	105
Falls of ground . . . . .	35,967	62,094	41,358
Shaft accidents . . . . .	851	825	486
Haulage accidents . . . . .	47,083	43,993	28,937
Other accidents . . . . .	43,063	56,441	35,844
<b>Total: Below ground . . . . .</b>	<b>147,131</b>	<b>163,484</b>	<b>106,730</b>
<i>Surface</i>			
On railways, sidings or tramways . . . . .	4,315	4,102	2,946
Elsewhere on surface . . . . .	7,596	9,603	7,626
<b>Total: Surface . . . . .</b>	<b>11,911</b>	<b>13,705</b>	<b>10,572</b>
<b>Total: Below and above ground . . . . .</b>	<b>159,042</b>	<b>177,189</b>	<b>117,302</b>
Per 1,000 persons employed	152	156	94
Number of persons employed <sup>1</sup> :			
Below ground . . . . .	848,381	909,834	990,359
Above ground . . . . .	201,026	218,056	257,865
<b>Total . . . . .</b>	<b>1,049,407</b>	<b>1,127,890</b>	<b>1,248,224</b>

The accident experience at coal-mines in the years 1919 and 1920 is similar and differs widely from that of 1910 and 1913 whether the disastrous explosions of the earlier years are included or not. Having regard to the exceptional conditions of the industry in 1919 and 1920, however, it would be premature to conclude that a permanent reduction of the magnitude indicated by the figures above had taken place in the number of deaths and injuries caused by accidents.

The staff of inspectors in 1921 numbered 81, or twice as many as in 1910; but greater regularity and frequency of inspection would appear to be a less adequate explanation of the diminished number of accidents than the growing self-consciousness of the workers as a class. This growth is the outcome of the improvement in the general standard of education, and it has been stimulated by the measure of responsibility with which certain classes of workers have been invested since the year 1910. Indications of this may be seen in the partial satisfaction of the demand for the appointment of practical miners as inspectors, in the number of apprentices, workmen and colliery officials who obtain certificates of competency each year as managers and under-managers of mines, and in the provision made in the Coal Mines Act, 1911, for the certification of firemen, examiners, and deputies. Altogether 115,000 candidates had up to

<sup>1</sup> Including persons employed at stratified ironstone, shale and fireclay mines.



1919 presented themselves for examination, the majority of whom were successful. Nor should sight be lost of the training of the rescue brigades in this connexion.

While the contribution of each and all of the factors referred to above cannot be ignored, the question arises whether some more fundamental cause may not be responsible for the greatly reduced number of accidents. Reference has already been made to the effect of the Minimum Wage Act of 1912 upon the rate of production of coal, and it is not inconceivable that economy of physical effort may have diminished the accident risk of the workers.

Statistics with regard to the mortality of miners show that although they appear to suffer more than the average from diseases of the respiratory system, the mortality of miners from phthisis is little more than one-half of the average, as is also that from alcoholism and liver diseases and from suicide. The mortality of miners from influenza, cancer, diseases of the nervous and circulatory systems and Bright's disease is also below the standard.

The virility of the miner as a class is further attested by the information obtained in 1911 with regard to the fertility of marriage. The class showed a higher number of children born per family than in any other social class, but it was also shown that in no other class of the community is the rate of child mortality higher. The importance of the housing problem for miners will be obvious.

**Position in 1921.**—The year 1921 opened disastrously for the coal-mining industry owing to a wave of industrial depression as widespread as it was severe. This was followed by a dispute of unprecedented magnitude with regard to the future regulation of wages (see STRIKES). The output of coal during the first quarter of the year was at the annual rate of little more than 215,000,000 tons, while during the whole of the second quarter nearly all the pits were idle. Nor were the effects of the industrial depression confined to the home market. When early in 1921 the restrictions on the supplies of coal for bunkering vessels and for export were finally removed, British supplies abroad came sharply into competition with those from the United States and with German coal supplied to France and Belgium by way of reparation.

Yet, disastrous as were the immediate consequences to the industry, signs were not wanting that the industry might be restored in the near future to a degree of efficiency not previously surpassed. The turmoil of recent years would have been in vain if it had not settled one or two fundamental questions in no uncertain measure. It was already clear that the time had not yet arrived when the State could with advantage to the community take over the ownership of the coal-mines, notwithstanding the conclusions of the Coal Industry Commission of 1919. But it was not less clear that the principles which had hitherto governed the relations of capital and labour in the industry were wrong. The regulation of wages by reference to the selling price of coal with its evil corollary—the limitation of supply—had gone beyond recall. The proposal made by the mine-owners in 1921 to regulate wages and profits in accordance with the prosperity of the industry was based upon principles as fruitful as they were sound, and now that ways and means for the adoption of the proposal have been found, it is not too much to say that a key has been fitted to the gates of a new world.

The ability of Great Britain to maintain its position industrially is largely dependent upon the existence of a cheap and plentiful supply of coal. Under efficient management no reasonable doubt can be entertained with regard to the ability of the industry to furnish these supplies, and certain qualities of coal produced are unrivalled. Moreover, their proximity to the sea ensures advantages which few other coal-producing countries possess, and it needs but a brief examination to show what abundant reserves of coal are still available.

**Reserves.**—In 1904 the Royal Commission on coal supplies estimated the reserves of coal within 4,000 ft. of the surface at 141,636 million tons. Sir Aubrey Strahan, formerly Director of the Geological Survey of England and Wales, re-examined the evidence and he concluded that 178,727 million tons of coal remained unworked in the year 1910. The quantity available, as thus estimated, would be in close agreement with the earlier estimate when allowance is made for the coal raised during the interval and the quantities which must be left for the support of surface buildings, barriers, etc. The latest estimate was that made in the year 1915 by Prof. H. Stanley Jevons, according to which the reserves of coal were placed at 197,000 million tons within 4,000 ft. of the surface. When the necessary deductions have been made for loss in working and for the coal raised since

1910, the quantity available for use would be some 13,000 million tons greater than the previous estimate.

Having regard to the proved extensions of the concealed coal fields of Yorkshire, Nottinghamshire and Kent since the earlier estimates were framed, it may be assumed with some confidence that the reserves of coal available in 1921 amount to not less than 135,000 million tons, and might amount to 150,000 million tons in addition to further considerable quantities at depths lower than 4,000 ft. or in concealed areas.

Some idea of the magnitude of the reserves of coal thus indicated will be gained from a consideration of the output since 1855 shown below. The quantities of coal shipped abroad and available for home consumption are added for comparison:—

Period	Coal Raised	Coal <sup>1</sup> Shipped Abroad	Coal Available for Home Consumption
	Million	statute	tons
1855 to 1860	412.8	38.5	374.3
1861 " 1870	974.9	94.0	880.9
1871 " 1880	1,311.0	187.2	1,123.8
1881 " 1890	1,642.6	314.7	1,327.9
1891 " 1900	1,954.4	457.8	1,496.6
1901 " 1910	2,453.7	732.8	1,720.9
1911 " 1920	2,530.5	654.3	1,876.2
Total 1855-1920	11,279.9	2,479.3	8,800.6

(R. F. T.)

## UNITED STATES

Previous to the 10-year period ushered in with 1911, bituminous coal production in the United States was scattered, uncoordinated and wasteful. The mines had a variable but large idle capacity, and the uncertainty of operations was at once a menace to the stability of the labour supply and to the maintenance of an adequate output: the technique and practice of storing coal were imperfectly developed, as was still the case to a great measure in 1920; the seasonal fluctuations of demand were uncompensated. These conditions were essentially the product of past circumstances—excessive competition, over-development of resources, and inadequate prices at the mine mouth, which led to poor engineering and low recoveries of values. The technology of production during the World War period—1914-8—showed great improvement, and there was evidence of growing industrial efficiency in extracting coal, although this progress was accompanied by excessive prices and an approach to monopolistic conditions. Bituminous and anthracite formed over a third of all U.S. freight in 1920, but transportation was the weakest link in the supply. Continuous mining depends on an unbroken movement of coal-cars past the mine mouths; and the number of coal-cars has never been equal to the full capacity of the developed mines. Unless railroad equipment becomes more nearly adequate, every period of industrial prosperity must result in a car shortage.

The United States had in 1920 the largest coal reserve of any country—about 3,527,000 million out of a total world reserve of 7,900,000 million tons, and a good reserve of each of the several classes of coal. For many generations there will be no danger of a shortage except of anthracite, good coking coal, and the highest grades of steam coal, which in 1920 were being actively mined. Each year found anthracite more of a luxury. Three thousand million tons of hard coal had been consumed, and the thinner, deeper and poorer seams were being mined. If the rate of consumption in 1920 continued, the United States would use up more anthracite between 1920 and 1940 than it did in the preceding 100 years. It is bituminous coal, therefore, that will support the future industrial life of the United States. According to geologists, the country had in 1920 upward of 1,400,000 million tons of the various grades of true bituminous coals in addition to 49,863 million tons of semi-bituminous, 987,514 million tons of sub-bituminous and 1,003,200 million tons of lignite. Of these total deposits, however, less than 5% were high-grade coals. Almost all the production before 1920 came from this better class of

<sup>1</sup> Including the coal equivalent of coke and manufactured fuel exported and the coal shipped as bunkers by vessels engaged in the foreign trade.

fuel. The earliest depletion of steam and gas coals will come in the fields that have supplied the great manufacturing districts of the eastern states.

Throughout the greater part of the country the large operating coal companies owned both surface and mineral rights. In certain districts coal land that sold in 1910 for \$50 an ac. brought \$700 in 1920. Seams that had netted the owners royalties of 6 to 10 cents a ton were often leased on a royalty basis of 30 cents per ton. In the Rocky Mountain region the Government sold the coal rights, but the state school lands of Colorado and Wyoming were generally leased at royalties of about 10 cents a ton. In the state of Washington a considerable area of the bituminous district was owned by the Northern Pacific railway, which had opened up the territory and had secured land grants from the Government. The royalty was from 15 to 25 cents a ton. In Alaska, in the Matanuska and Bering river bituminous fields, and in the Nenana lignite field, the Government offered the coal for leasing at 2 cents a ton for the first period, under restrictions providing for conservation and reasonable prices to consumers. Some units were taken up in the Matanuska and Bering river fields, but as the measures are badly contorted and the coal-beds difficult to trace progress was slow, and in 1920 production had scarcely begun. In 1920 the Alaskan Railway Commission was working some mines temporarily at Chickaloon and Esak creek to obtain a supply of coal pending the development of other mines by leases. Congress, in opening the coal lands in Alaska for leasing, reserved tracts of not exceeding 7,680 ac. and 5,120 ac. respectively in the Matanuska and Bering river fields, for the use of the navy. In the western states the Government still owned large areas of coal and lignite lands generally remote from railways and difficult of access, but containing enormous reserves. In 1920 the Gebo mine at Gebo, Wyo., was the only one leased to an operating company by the Government, but the extension of a leasing system similar to that proposed for Alaska will ultimately be effected.

In the United States the two branches of coal-mining—anthracite and bituminous—present totally different aspects. In fact, it has become almost an axiom that what is true of the anthracite industry is untrue of the bituminous industry. The anthracite industry is well organized, and railroad connections make it notably efficient and powerful. Bituminous coal, on the other hand, is so widely distributed on both public and private lands that no organization of private companies was ever able to control the industry. All centralized control of coal production was always opposed by Congress and the general public. Only during the World War did the United States attempt to exercise authority over commercial mining and the sale of coal. A fuel administration was created, and coal was shipped under its instruction and at prices fixed by it. Government control practically disappeared with the war. There was a growing feeling, however, that production and distribution should be classed as a public utility and regulated.

In the 10 years from 1891 to 1900 the average annual working time of the mine workers in the anthracite regions ranged from 150 to 203 days, with a mean average of 176 days. During this period the entire anthracite industry was demoralized. A great strike occurred in the hard-coal region in 1902. President Roosevelt appointed a commission, and the anthracite industry emerged from the difficulties plus a Board of Conciliation, composed of representatives of the operators and the miners, which was still in power in 1920. Under this plan the annual working time in the hard-coal mines increased gradually to 229 days in 1910, about 30% over the annual average working time of the 10-year period preceding the appointment of the Board. From 1911 to 1920 the annual average never fell below 230, and the mean was 255 days. The better conditions for miners in the anthracite field after 1902 were not solely due to increased annual working time. Between 1902 and 1920 there was also an increase in wages of something like 85 per cent. In the period 1900-10, the production of anthracite per man per day increased materially, but the next decade, 1910-20, showed a drop, due to the reduction of the length of the working-day from nine to eight hours.

In 1920 it seemed practically impossible to duplicate in the bituminous fields the conditions existing in the anthracite region. The anthracite mines all lie in a small area of one state, Pennsylvania. The collieries were all owned by a few large companies, which rendered it possible to centralize the control in a few men. But bituminous coal in 1920 was mined in 27

states, various producing districts competing for the same markets. It was because of this wide distribution of soft coal that it had never been possible to bring about unified action. Yet production managed to keep pace with the country's normal industrial growth. The industry grew from an output of 111,000,000 tons in 1890, from mines whose aggregate capacity was estimated at 150,000,000 tons and which employed 102,000 men, to the record figures of 1918, when the output was 579,000,000 tons, the mine capacity approximately 715,000,000 tons, and the mine workers numbered 615,000.

Analysis of the records over the 30-year period 1890-1920 shows that coal output and labour employed during this period increased largely, and that the production of the average mine-worker was greater. Output fell off, however, in the years of general business depression—1894, 1904, 1908, 1911 and 1914. Mine capacity kept well in advance of output, largely because of ever-increasing expenditures in mine equipment, which also largely account for the increased average production per man underground from 579 tons in 1890 to 4,134 tons in 1918.

The considerable time lost in the soft-coal industry is shown by the fact that in only seven of the years during the period from 1890-1919 was lost time less than 25% of the working year. That coal-mines are idle for many days in the year is familiar to everybody acquainted with the industry; but what is not generally realized is the amount of time lost. During the 1890-1919 period, out of 308 possible working days a year, the bituminous mines were idle on the average 93 days. Ten times during that period the time lost exceeded 100 working days. The greatest loss was in 1894, when the average for all mines was 137 days, or 44% of the working year. The smallest loss occurred in 1918, the year of record production; yet even then the mines were closed down for one cause or another for the equivalent of 59 days out of 308—nearly one-fifth of the time. These figures for lost time indicate only the days that the mines were not operated. Absenteeism of a part of the force when the mines were running still further reduced the output. The greatest extremes in output occurred in 1914, when the rate of production rose in March to 123% of the monthly average for the year and fell in April to 66%. The high rate was nearly twice the low. In that year two influences were at work: the normal seasonal fluctuation was intensified and distorted by the biennial wage negotiations. The normal April slump was aggravated by strikes, in anticipation of which there had been anxious buying in March. The year 1914 may be taken as a somewhat exaggerated example of the fluctuation to be expected in an "even" year—the year of biennial wage adjustment. In one respect, however, 1914 was not typical. The autumn peak came in Sept., and was followed in the last quarter of the year by a depression which was one of the effects of the outbreak of the World War. In other years the peak was reached in November.

When monthly fluctuations represent seasonal fluctuations in demand only, uninfluenced by labour disturbances, as in 1913, such a year may be accepted as a fair type of the "odd" year in local production, when the biennial adjustment is not a factor. In such a typical year the capacity required during the month of maximum demand will be from 35 to 40% greater than in the month of minimum demand. In other words a mine capacity and a labour force sufficient for Nov., if working full time, would be employed in April only 70 to 75% of the time; and as in actual practice the mines never attain 100% or full time, even in Nov., but under the very best of conditions reach only 80% the time of employment to be expected during April is about 50%. Rate of mining in April 1919 was only 50% or 24 hours out of a 48-hour week. The highest weekly percentage of full time averaged by full-time bituminous mines was 86% during July 7-13, 1918. The average for that particular month was 84.4. In Sept. 1918 an average of 84.9% was reached. In Nov. 1917, however, when the demand was intense but the zone system and other features of wartime control of distribution were not in force, the percentage averaged was only 75.3. To put it in another way, even in years of active demand the inequalities in the summer and winter buying of coal render inevitable a long period in which the labour and capital engaged in the industry cannot work more than 27 to 30 hours out of a 48-hour week. This is not the measure of working time necessary to meet demand. The 30-hour week is almost invariable during springtime in the bituminous coal industry.

Under the conditions obtaining in 1920 there was a third set of fluctuations in addition to the annual and seasonal fluctuations in production. The railways work seven days a week; the mines only six. Over Sunday the carriers catch up in their work of placing cars, and in consequence of the better car supply the miners work longer on Monday, but later in the week their hours show a gradual decline, accentuated on Saturday by holiday absenteeism. Even if the mines should obtain full time on Monday, which in practice they never did, they could not expect to work more than 86% of the time on Friday and 79% on Saturday. But the Monday rate never in practice gets up to 100%, and the performance on the latter days of the week is correspondingly defective. A significant, if rough, relation exists between the loss of working time in the soft-coal industry and the degree of unionization. Those bituminous

regions in which interruptions were most pronounced showed a tendency to become union territory. The presence of the union is both cause and effect. Wage disputes cause lost time, but on the other hand, irregular employment is a prime incentive to unionization. Full-time operation, if it could be brought about, would reduce production costs per ton. Careful investigation of many mining operations disclosed that the cost of mining varied as much as 60 cents a ton from one month to another, depending on the number of idle hours. A coal-mine differs from a factory, which when closed needs only a watchman to guard it. In an idle mine the forces of nature are busy: there are roof and floor movements that change the haulways; there are gas exudations and inflows of water with which to contend. An idle mine cannot be left unattended, without heavy loss. In mining the costs go on even if the coal is not produced.

At the end of 1920 experts agreed that there was no prospect of a return to pre-war prices because of the larger difficulties of mining less favourable seams, more costly equipment, higher wages and increased freight rates. These changes seemed likely to cost the people of the United States upward of a thousand million dollars annually as compared with the fuel bills of 1914. During the period 1900-20, the population of the United States increased 42%, and the consumption of coal 172%. Mechanical means, more and more employed to do work formerly done by hand, consumed more power, and coal was the chief source of energy. Assuming that the population and industrial growth of the United States continue unchecked, and that the use of coal increases accordingly, by the year 1940 the United States will be consuming 1,400,000,000 tons of coal annually. It would be wholly impossible for the system of American railways as constituted in 1920 to handle any such production and at the same time carry the normal increase of other freight. It appeared essential, therefore, that immediate thought be given to the important problem of a national power supply.

There were in 1920 about 8,000 commercial or shipping mines producing bituminous or anthracite coal in the United States, and about 12,000 "wagon mines," or "country banks," supplying local trade. Kentucky, West Virginia and Ohio had the greatest number of these small openings. Though the total production of these country banks was less than 1% of the total output, the effect of dumping their unprepared and inferior product on the general market was not desirable, and as a miner can produce from two to four times as much coal in a properly developed colliery as in the average wagon mines, the effect on the labour situation was adverse.

The whole American coal industry in 1920 employed 750,000 men in and about the mines. The operations in the Appalachian fields, from the Tennessee-Kentucky line N. into Pennsylvania, furnished the bulk of the bituminous coal used in New York and

New England. The Appalachian region also provided all the bituminous coal exported to Canada. Consumers required shipments of at least 28,000,000 tons monthly from the mines. In winter all this output was consumed as fast as produced, but in summer consumption dropped to approximately 24,000,000 tons a month. The remainder, about 4,000,000 tons a month, normally served to build up winter stocks in New England, the north-western states and Canada. An analysis of coal production in the United States by periods and decades from 1807, and by years from 1908, is given in the annexed table in short tons.

The table illustrates the great increase of American industry, which absorbs nearly all of the bituminous production. Gauging the industrial development of the different nations by the per capita consumption of coal, it is interesting to note that in the United States the annual consumption per capita in 1920 was six tons; in the United Kingdom it was estimated to be 5.1 tons; in Germany 3.4; France 1.2; Italy 0.34; and Russia 0.18. Before the outbreak of the World War in 1914, Belgium was consuming about four tons of coal per capita, which indicated its intense industrial development. While the output of European nations steadily decreased in recent years, the production of the United States increased. American mines in 1918, as shown by the table below, under stress of war demands broke all records, producing nearly 600,000,000 tons of bituminous coal. The average production per man during that year was 1,134 short tons. The closest competitor was New South Wales, where each underground worker in 1918 produced 814 tons. British Columbia ranked third with 790 tons, and Nova Scotia fourth with 718.

Mining machines played an important part in the development of coal-mining in the United States in the period 1910-20. In 1918 18,463 machines were in use in the bituminous mines, an increase of 1,228 over 1917, and 2,265 over 1916. The tonnage mined by machine in 1918 was 323,931,000, an increase of 17,535,000 tons, or 5.7% as compared with 1917. No great change occurred in the proportionate machine output for 1920, because the intense demand called forth a large production by hand as well. In 1916 the proportion of the total output mined by machines was 56.5%, in 1917 it was 55.5% and in 1918 59.9%.

Of the annual bituminous production in the United States in 1920, 40% was used for steam or industrial purposes, 27% was burnt by the railways, 15% was used for household purposes and the remaining 18% consumed in coking, exports, smelting, gas-houses and bunkering. Assuming that it is possible to obtain the by-products from only 25% of the industrial coal and from 50% of the railway coal through establishing control stations and electrifying, also that the household coal can be coked first (which could be done if modified ranges and furnaces were used), it has been calculated that 105,000,000 tons of bituminous coal in 1920 was burned raw in the United States should have been coked. If but two-thirds of this tonnage could have been subjected successfully to by-product coking, the saving would have amounted to at least \$28,000,000. In other words, more than \$200,000,000 went up in smoke from American plants in a year. Production of coke in 1920 was nearly 57,000,000 tons. Of this quantity approximately 30,000,000 tons were produced in the old-fashioned beehive ovens and the re-

Years (Inclusive)	Pennsylvania Anthracite	Bituminous	Total	Period Totals
1807-20	12,000	3,000	15,000	
1820-25	71,141	256,040	327,181	
1826-35	3,007,371	1,160,778	4,168,149	End of 1865
1836-45	13,393,484	9,784,153	23,177,637	284,900,808
1846-55	31,948,337	31,469,490	63,417,827	
1856-65	98,593,540	75,201,474	173,795,014	1807-1885
1866-75	178,401,722	220,088,512	419,475,104	1,552,086,231
1876-85	309,401,722	537,768,582	847,170,319	
1886-95	386,784,754	1,999,313,887	1,582,098,641	1807-1905
1896-1905	612,395,214	2,220,007,532	2,832,402,746	5,970,587,618
1906-15	851,878,227	4,066,839,056	4,918,717,283	
Annual Production During Period 1908-20 Inclusive.				
1908	83,268,754	332,573,944	415,842,698	
1909	81,070,359	379,744,257	460,814,616	
1910	84,485,236	417,111,142	501,596,378	
1911	90,464,067	405,907,989	496,371,126	
1912	84,361,598	450,104,982	534,466,580	
1913	91,244,982	478,435,297	569,680,279	
1914	90,821,807	422,703,970	513,525,477	
1915	88,995,061	449,624,426	538,619,487	
1916	87,578,493	502,510,682	590,089,175	
1917	99,611,811	551,790,563	651,402,374	
1918	88,826,084	579,386,000	678,212,084	
1919	88,000,000*	458,063,000*	546,063,000*	
1920	89,000,000*	556,500,000*	645,500,000*	
Total 1908-1920	1,158,007,892	5,977,464,322	7,135,472,214	

\*Estimated.—Bituminous coal in the United States is mined and sold in short or "net" tons. Anthracite is mined and sold in long tons. The figures in the table for anthracite have been reduced to net tons to make them correspond to the bituminous figures.

NOTE.—Anthracite production exceeded bituminous until after the Civil War. After that time it became less proportionately, from year to year. In 1908 bituminous production had become about four times as great as anthracite, and in 1918 it had become nearly six times as great.

maintaining 27,000,000 tons came from by-product ovens. The maximum capacity of the by-product plants of the United States has been estimated at 27,000,000 net tons of coke at the beginning of 1908, 33,700,000 at the beginning of 1919, and 39,500,000 at the beginning of 1920. These estimates were based on 100% operation. In actual practice, however, an average operation above 90% cannot be assumed; and for the country as a whole 85% is a safer figure. This would show the capacity for 1920 to be 33,475,000 tons.

Estimated according to the quantity of by-product coke produced in 1919, 25,171,000 tons, by-products recovered during that year were 668,200,000 lb. of ammonium sulphate or equivalent, 251,000,000 gal. of tar, 84,800,000 gal. of crude light oil, and 367,700,000 cub. ft. of gas. The largest by-product coke plant in the world in 1920 was that of Clairton, Pa., owned by the Carnegie Steel Co. This plant carbonized 12,500 tons of high volatile coals daily, producing 8,000 tons of metallurgical coke, 150 gal. of coal tar, 75,000,000 cub. ft. of gas, 40,000 gal. of light oil and 174 tons of ammonium sulphate each 24 hours. The comparative production of these results varies in different parts of the country.

In contrast with the reserves of coal in the United States and the annual production, the exports in 1913 (a normal year) were only about 12% of the exports of coal from all other countries; and a large part of the American exports went to Canada by rail. Of sea-borne coal, the United States sent out only about 4%. This small proportion of over-seas trade is due to the distance of American coal from seaports, the lack of organization among operators and among related shipping organizations, and further, to the relative independence of the United States, which could utilize only a small amount of imports from most countries as a return cargo for coal-exporting ships. Most of the American coal was used at home, but the advantage of exporting a considerable quantity of coal, for its effect in increasing trade relationships with other countries, was becoming more manifest. During a part of the autumn of 1919 the United States exported coal at the rate of 65,000,000 tons a year. This was practically every pound of coal that could at the moment be loaded into ships at the Atlantic ports. The total coal-loading capacity of all the Atlantic coast export docks was about 31,000 tons per 10-hour day. It was this limited coal-handling facility which militated to a large extent against the United States gaining a permanent position as the world's leading coal export nation.

The war opened several foreign markets, especially in South America, to U.S. coal. The United States had coaling stations as far away as the Samoa Is. and Manila, but little coal reached them from America. American coal supplied the Government coaling stations in Alaska, Hawaii, the home ports both Atlantic and Pacific, Cuba, Porto Rico, Nicaraguan ports, Panama Canal ports, Mazatlan (Mexico) and South American ports.

**U.S. Government Control, 1917-20.**—On April 6 1917 the United States entered the World War, and centralized wartime control over the coal industry was delegated by President Wilson, in May 1917, to an officially constituted Fuel Board, with Francis S. Peabody, a practical coal operator, as chairman. Soon after the formation of the Board, plans were announced for the stabilizing of coal prices, the collecting of production statistics, and the efficient distribution of coal.

The Fuel Board acted as a kind of clearing-house, collating and digesting the vast mass of information needed. In June 1917 labour was given representation on the board, and the way thus smoothed for more efficient coöperation between the board and the mine workers. Keenly desirous of efficiently handling the coal situation, the Federal Trade Commission, through the Fuel Board, made recommendations which created surprise, as no such drastic measures had been expected. In essence, the most important of these recommendations were:—First, the institution of a pooling arrangement, to be placed in the hands of a Government agency, to control the production and distribution of coal and coke. The producers were to be paid their full cost of production plus a uniform profit per ton, with due allowance for quality of product and efficiency of service. Second, all agencies of transportation, by both rail and water, were to be similarly pooled and operated on Government account, as a unit, under direction of the President. The owning corporations were to be paid a fair compensation, which would cover normal net profit, upkeep and betterments.

In the latter part of June 1917, after conferences with the coal operators, the Fuel Board (then known as the Committee on Coal Production) made sweeping reductions in the current prices of bituminous coal, which had been showing a tendency to rise to unheard-of levels. Early in these conferences it be-

came apparent that a national organization of coal operators would be necessary to carry into effect the price-fixing and other plans of the Government. A tentative organization was formed, composed of the secretaries of the 25 coal-trade associations which were represented at the sessions. C. P. White, of Cleveland, was chairman of this new body, and C. E. Leshar, statistician of the U.S. Geological Survey, was secretary. The association was to work in conjunction with Mr. Peabody's committee, and to be supported by an assessment not to exceed one-quarter mill per ton, levied on all operating coal companies in the United States. By Aug. 1 1917 the pooling arrangement suggested by the Federal Trade Commission was in full operation. All shippers of tidewater bituminous coal had agreed to pool their output at the ports of New York, Philadelphia, Baltimore and Hampton Roads. The regulations fixing maximum prices for coal, announced by the Committee on Coal Production, were carefully observed by the coal operators, although the new figures had been characterized as "unjust" in some quarters and as "exorbitant and oppressive" by Secretary of War Baker, who wanted cheap fuel for the navy.

The prices set by the Committee on Coal Production were short-lived, for on Aug. 21 1917 President Wilson took price-fixing into his own hands and prescribed provisional prices to cover all the bituminous-coal-producing districts of the country. The new figures were one-third lower than those agreed upon voluntarily by the operators in concert with Mr. Peabody. The announcement of the new prices stated that they were based upon actual cost of production and were deemed to be, not only fair, but liberal. Provision was made, however, for a reconsideration "when the whole method of administering the fuel supplies of the country shall have been satisfactorily organized and put into operation." All the coal operators in the United States were called upon by the Board of Directors of the National Association of Coal Operators to meet Aug. 29 1917, at Pittsburgh, to discuss the latest ruling.

Soon after the President's announcement fixing the prices of soft coal, came the setting of prices of anthracite coal, the specification of the margin of profit that could be charged by a jobber and the naming of a coal controller. In a fifty-word statement, President Wilson announced that, in accordance with an Act of Congress approved Aug. 19 1917, he had appointed Harry A. Garfield, president of Williams College, as his fully empowered representative on control of fuel.

The new schedule of coal prices had no appreciable effect on anthracite, though it threw the bituminous trade into confusion. Practically all coal disappeared from the market, and delegations from all parts of the country rushed to Washington in an endeavour to have the prices on bituminous coal increased. Dealers who had purchased stocks of coal at prices considerably above the latest Government figures were in a quandary. On Sept. 8 1917 Mr. Garfield made public his plans for controlling retail prices of coal by the formation of local fuel administrators in every coal-consuming section of the country. Soon after, intimations came from Washington that the President's provisional prices for bituminous coal would be increased, as the original schedule had tended to decrease production. In the autumn of 1917 the educational department of the Fuel Administration, in the daily press and in circulars, posters and pamphlets, began to preach economy to both domestic and industrial coal consumers. Industries that were not strictly necessary to the winning of the war became apprehensive as to their future coal supplies. Through the fall of 1917 the demand for both anthracite and bituminous coal was urgent, and many sections of the country were in dire straits for want of soft coal. The price of bituminous had been increased 45 cents meantime, the advance being made to cover the increase in the miners' wage scale that had gone into effect.

By Dec. 1917 it became evident to those in the coal industry that the Fuel Administration would brook no interference with its plans. The personnel of the Administration had been growing since its inception, and there were organizations in most of the states of the Union. With the coming of the exceptionally cold

winter of 1917-8, came more urgent demands for coal from all classes of consumers. New England in particular was in distress, and large cities such as New York could get but little hard coal for heating. The great tonnage which the railways were called upon to handle congested the yards, terminals and equipment so that it became impossible to supply quickly even the most vital needs. Embargo followed embargo, and preferential shipment orders for sundry commodities further hampered transportation. Dr. Garfield stated that adequate coal supply depended in large measure upon more ample transportation. Every soft-coal operator reported a shortage of coal-carrying equipment, and although the clamour for relief was loud and long, no one seemed to know just what steps to take to ameliorate this condition.

The attempt was then made to deal with the problem by conservation. Estimates by the fuel authorities indicated a shortage of at least 50,000,000 net tons of bituminous coal. As there seemed to be little likelihood of output catching up with demand, reliance was placed on securing less waste of coal in large plants and in curtailing unnecessary uses of power. David Moffat Myers, advisory engineer of the Fuel Administration, in consultation with conservation committees and engineers, formulated a plan to reduce fuel waste in power-plant operation, not by costly installations of more efficient apparatus, but by a more intelligent and careful use of existing equipment. It was proposed to ascertain first how far each plant complied with certain well-recognized standards in its operation and maintenance, and then, by a system of rating degrees of efficiency, to force on the attention of the plant management such wasteful conditions as were disclosed. To supply a strong incentive for improvement, it was announced that the relative rating of plants would influence the Fuel Administration's allotment of coal should a shortage occur. The plan further included a programme of education through lectures, Government publications, meetings of plant owners, engineers and firemen. This campaign in each state was to be in the hands of an experienced power-plant engineer who, with his staff of workers, should be a part of the conservation division of the state Fuel Administration. Printed "Recommendations of the United States Fuel Administration" were issued establishing the standards of plant operation and maintenance as well as a questionnaire to ascertain from the power-plant owner the condition of his plant with relation to these recommendations, and to obtain the initial information for rating. It was an essential part of the plan that this information be confirmed or amended by an accredited inspector after investigation of the plant itself.

As a climax to Dr. Garfield's frequent statements, that the railways were chiefly responsible for the deplorable situation, came the proclamation by the President on the night of Dec. 26 1917, by which the Government took over the railways. At this time the efforts to relieve congestion on the railways were beginning to bear fruit in the shape of a slight improvement in the car supply at the mines. On Jan. 16 1918 came the order shutting down business for five days and closing up industries on every Monday until March 25. The storm of protest which this evoked was far louder than any that had greeted the other revolutionary edicts of the Fuel Administrator. There had been no advance notice of the order, and following its publication the U.S. Senate, with only 19 adverse votes, passed a resolution, introduced by Senator Hitchcock, requesting a five-day suspension of the order to allow those opposing it to be heard. Nevertheless, the order was obeyed with a promptness that clearly showed the resolution of the public. On Feb. 13 1918 the order providing for "heatless" and "workless" Mondays was suspended. Although it was admitted in official circles that little coal had been saved by the order, it was generally acknowledged that it had stimulated the railway managers and had relieved to some extent the freight congestion.

After months of preparatory work, the Fuel Administration on March 22 1918 announced a zoning plan for the distribution of coal, to take effect April 1 1918. Every state in the Union

was affected more or less. The aim was to confine coal produced in the eastern section of the United States to eastern markets, and make it compulsory for states in the Middle West, as well as in other sections, to use coal produced in mines near by. The announcement was received by the coal-mining industry with mixed feelings. Many operators and shippers who had spent years in building up their trade suddenly found their best customers taken from them. Consumers who had been accustomed to burning certain kinds of coal were forced to use fuels with which they were less familiar. But producers and consumers alike readjusted their methods to conform to the new order of things. The coal trade was still further convinced that the Government intended to control the entire output of fuel, from the time it left the mines until it was in the consumer's bin, and even in the furnace, when Dr. Garfield on April 1 1918 announced that coal jobbers must procure licences. Many abuses had arisen which the Government desired to eliminate, and the licensing plan was announced as fair to the operator, to the *bona-fide* jobber and to the consumer. The new system enabled the retailer to buy direct from the producer, whereas he had before been able to deal with the jobber only.

With the railways under its control, the Government had made material progress in the task of clearing the path for a quick movement of coal from mine to consumer. New prices had been announced, and the local fuel administrators had perfected their organizations to take care of distribution. In many producing districts the car supply was still below normal, however, and not sufficient motive-power was available. The railways had shown little improvement in the method of allotting empty cars to the mines. Before the Railroad Administration assumed control, it had been the practice of some railways to allot cars to those operators on their lines who favoured the carriers in respect of prices. John Skelton Williams, in charge of purchases for the Government-controlled railways, insisted that the Railroad Administration had the right to distribute cars where and how it pleased. This was a continuation of the old policy of using such control of shipping facilities as the railway possessed to force concessions in price from the coal producers, and it was in direct antagonism to the Fuel Administration's endeavour to further the production of fuel. Thus one Government body set at naught the edicts of another.

This action on the part of the Railroad Administration served as did nothing else to bring to the support of Dr. Garfield many of the coal operators who had been inimical. With the warmer weather of May 1918 came admonitions from the Fuel Administration that consumers would best serve their own interests, and those of the nation, if they laid in their winter coal supplies during the summer. The production of both anthracite and bituminous coal had been steadily increasing, though inadequate car supply still prevented a maximum output of the latter. By June 1918 it had become apparent to those interested that the coal industry was being organized as it never had been before. The Fuel Administration, under Dr. Garfield, was accomplishing the seemingly impossible. Weekly reports kept him conversant with the actual output and consumption of coal in each zone, and a watch was kept on the needs of each section. Coal was in many instances diverted in transit to provide for emergencies. Quotas had been fixed for cities that were permitted to burn anthracite, none of which was to be sent west of the Mississippi or south of the Potomac or Ohio rivers. Industries deemed unessential to the winning of the war were being denied the use of any kind of coal. By July 1918 the coal industry was hard and fast in the grip of governmental regulations and administration. Competition had ceased. The railways and the fuel authorities were working together in harmony, and the bituminous mines, under the stimulus imparted by Dr. Garfield's newly formed production bureau, were producing record tonnages. The difficult task of inciting the soft-coal miners to greater endeavours was placed in the hands of James B. Neale, who had been acting as adviser to Dr. Garfield. In Aug. the Department of Labor classified coal-mining as "war work," in order to keep the

miners from leaving their tasks for other war industries, such as munitions and shipbuilding, where higher wages prevailed.

Conditions in the latter part of Aug. 1918 were about as follows:—That part of the United States lying roughly between the Rocky and Allegheny mountains appeared to be fairly well supplied with fuel, though Michigan was complaining of a shortage of domestic coal. The scarcity of coal seemed to be worst along either coast. New England, while admitting that coal was coming forward in adequate volume for immediate needs, nevertheless was apprehensive as to the future. On the Pacific coast, industries were somewhat short of fuel; although little anxiety was felt, it was anticipated that wood and other fuels would have to be used there during the winter. By the middle of Oct. even the most carping critic was forced to admit that Federal control of the coal industry was beneficial. In charge of all production and distribution facilities, the Fuel Administration had carried out many of the plans which it had formulated early in the year. In the face of apparently insurmountable obstacles and of bitter criticism from many quarters, Dr. Garfield and his assistants had laboured steadily until disorder had given way to order. New England and a number of other important industrial centres had ample reserve stocks of fuel against the uncertainties of mining and shipping conditions in winter, a complete reversal of the conditions that obtained in the autumn of 1917, a year earlier.

The need for quantity production of soft coal being less urgent, the Fuel Administration again turned its attention to quality. During the week ended Oct. 28 1918, orders were issued to a number of bituminous coal miners prohibiting them from mining or shipping their product, as it was of an inferior quality. The Fuel Administration closed down 99 mines in its campaign for clean coal. Early in Nov. 1918 a surplus of soft coal was reported from practically every mine west of the Mississippi river, this unusual condition being attributable largely to the expectation of an early peace which led manufacturers of war goods to stop buying coal, and partly to exceptionally mild weather throughout the country. On Nov. 11 1918 the signing of the Armistice practically ended the activities of the Federal Fuel Administration. Government control of prices and other regulatory measures of the Fuel Administration were suspended Feb. 1 1919, but control of the coal industry was again established Oct. 30 1919, when all regulations were restored, in order to deal with the results of a strike in the soft-coal fields. These regulations continued in force until April 1 1920, when the coal industry was returned to its owners.

Apart from the phases of the conservation work carried on by the Fuel Administration as already described, other fuel-saving plans and recommendations were either discussed or put under way. These activities may be classified as follows:—

**Interconnection of power plant.**—This meant that municipal electric plants should connect with central stations; that isolated office-building plants, as well as industrial plants, should shut down and take power from central stations; and the interconnection of hydro-electric plants with steam electric plants.

**Skip-stop.**—Many street-railway companies of the United States adopted the "skip-stop" system for the saving of fuel by passing many streets without a stop; stops were taken to decrease coal consumption by automatic control of heat on cars and by the elimination of unnecessary street-railway service.

**Industrial gas.**—The managers of foundries and other industrial plants in sections of the country where artificial or natural gas was available, were induced to substitute this form of fuel for hard coal or coke. Many restaurant proprietors and bakers were persuaded to abandon solid fuel for gas.

**Domestic heating.**—Although domestic heating consumed only a small portion of the total coal output, methods of burning fuel in domestic heating equipments were improved, and faulty installations were corrected.

**Wood fuel.**—Various local Fuel Administrators devoted themselves to ascertaining where dead timber was obtainable and, through women's organizations, boy scouts, and other volunteers, this fuel was sawed and distributed, taking the place of coal.

**Lighting restrictions.**—The use of electric illumination for display purposes was curtailed.

Efforts in the direction of conservation ran from the smallest consumer, who carried his coal home in a pail, to the huge coal-

consuming corporations in the large industrial cities. What the Federal Fuel Administration accomplished cannot be accurately measured in terms of coal saved, though it may be stated that it amounted to many millions of tons. (F. W. P.)

**COAST DEFENCE** (see 6,599).—Broadly, the term "coast defence" might be said to include all military and naval measures taken to defend the sea-margin of a country against any attack by an enemy conveyed by vessels on or under the surface of the water. But the usual military meaning is a much narrower one, and may be taken to denote only the fixed defences of a coast and their various accessories. Even this requires qualification. Unless the sea-margin be a very short one it is not practicable to defend it efficiently by any defences tied down to the coast-line concerned. The cost in men and material would be very great, and the whole, being rendered immobile, would be incapable of use in any other part of the theatre of war. So far as these forces were concerned initiative would always rest with the enemy who could attack or not as he liked. Victory lies with the attack and not with the mere parrying of a blow. Therefore, any country desiring victory must be prepared to strike, and for this reason must limit purely passive defence to its minimum; and defences tied to a coast are purely passive.

It is true that a country with very weak naval forces often tends to increase its coast defences as compared with another power possessing a strong navy. But even here this tendency should be carefully limited. The hostile navy will hardly ever be able to compel victory by itself; land operations will be necessary, and every effort should be made to conserve energy to combat these. The real defence of a coast, in the plain English of the words, lies in beating the enemy. The numerous coast guns on the east coast of the United States of America never fired a shot in the Spanish-American War; that coast was defended at the naval battle outside Santiago de Cuba. Practically then it may be said that coast defence, in the present military acceptance of the words, refers to the fixed defences at certain limited portions of a coast which, as will be seen later, are vital to the whole general fighting scheme of the country.

This view in its entirety has not always prevailed either in England or in other countries, and it may be said that the modern British scheme of coast defence has only been accepted since about 1885. Some years earlier the so-called Palmerston Commission, which commenced its sittings in 1859, had carried out a very large scheme of coast fortification which, although it concentrated the defences at certain important harbours, still was so far imbued with the ideas of the past that it caused its works to be much too heavily gunned, and so locked up too many men and too much material.

Starting with the experience gained at the bombardment of Alexandria in 1881 the British school of thought on coast defence, as it existed before the World War, gradually took shape, and its ideas were crystallized largely owing to the influence of Sir George Clarke (Lord Sydenham).

The World War has naturally caused changes in this as in every branch of the military art. Opinions are expressed to the effect that the whole scheme of coast defence must be radically changed, owing to the theory that surface craft are practically doomed and that the weight of a future attack will come from the air or under the water. This is almost certainly to anticipate the future too rapidly. The use of aircraft and the expansion of the use of the submarine boat have undoubtedly caused great changes. But they are *changes* and not *revolutions*. History shows that no inventions in the past have ever caused sudden revolution in the art of war. It will be found that the new arm or the fresh invention take their place in the armoury of war alongside of, but at first not in place of, what has gone before. In time the old weapon may be discarded altogether, but sometimes this does not happen. In the matter under consideration surface craft must always be used for ordinary commercial purposes, as less energy is required to move a given mass floating on the water to what is necessary to move it in the air or completely submerged in the sea. These surface craft being in existence will certainly have to be used in warfare. Also, the



present stage of mechanical engineering, advanced as it may be considered to be, hardly warrants the belief that a surface war fleet, with all which that implies, can be completely replaced now by aircraft or submarines or a combination of both. The art of war is constantly changing, but by a gradual progress, and many of the old views with *modifications* will be found to be sound in the future as in the past. Amongst these it is contended that the basic principles underlying British schemes of coast defence before the war will be found to have been of this sound nature, and only require modification in detail.

In order to understand these general principles it is necessary to consider the whole question of the contest between the ship and the shore defences, the main element of which is artillery. These two contestants have never been on an equality, and that for various reasons which may be briefly recapitulated:—

(1) *Gun Platform*.—The shore gun is on an immovable platform while the naval gun is not. It may be taken that a shore gun presents a vertical target of about nine feet. This subtends an angle of slightly over 30 sec. at a range of 20,000 yards. Assuming a naval gun correctly aimed at the centre of this target a movement of the gun of 15 sec. in the vertical plane containing the trajectory of the shell at the moment of firing would be sufficient to throw the gun off the target. Such a movement is almost imperceptible on a ship.

(2) *Control of Fire*.—On a ship the means of range-finding are necessarily restricted within the dimensions of the ship and its masts, while the shore gun has the whole coast within the limits of vision to use for purposes of bases for range-finding. It is true that in these days aircraft can be used for correcting fire, but the results of this are not so accurate as those from terrestrial instruments, and in any case aircraft can be used by both sides.

(3) *Ammunition*.—The supply of ammunition of the shore gun is naturally kept up more readily than that of the gun afloat.

(4) *Visibility of Target*.—So long as a ship is within the horizon it cannot conceal itself except by means of a smoke screen. This latter has disadvantages from the point of view of offensive action from the ship. A shore gun on the contrary can be rendered very inconspicuous, and in many cases may be invisible from the sea behind a fold of the ground, using indirect fire.

(5) *Target*.—Apart from the visibility of the respective targets their vulnerability differs. It is not difficult to design a shore battery so that only a direct hit on the gun itself will put it out of action, all other parts of the battery being fully protected. At Tsingtao on Oct. 29 1914 ten large shell from H.M.S. "Triumph" were observed to burst just inside Fort Itlis, but none of the guns of the fort were damaged. With the ship, on the contrary, there are many parts, other than the guns, damage to which would materially affect its fighting efficiency. Examples of this occurred on March 18 1915 in the Dardanelles.

To a certain extent these unequal conditions have always existed, but when they are examined it will be seen that the increase of power of artillery and improved methods of range-finding tend to put the ship's guns more and more at a disadvantage. When the effective range of artillery was about 1,000 yd. it was very difficult to make anything inconspicuous on shore, and range-finding instruments did not exist at that time. In these days of ranges of 30,000 yd. and more, shore guns become practically invisible from a ship even if they are in direct view from the sea, and range-finders may be situated several miles away from the guns they serve and give no indication of their presence. It is true that with modern ranges it cannot be expected that shooting can be very constant; there are too many factors to prevent it. But this fact is at least as disadvantageous to the naval gun as to its rival on shore. Guns are not mathematical instruments. Their shooting powers are affected by very slight variations of propellant charge in quality and in quantity, of weight of projectile, of the amount by which the latter is rammed home in the bore, and by the wear of the gun itself, not to speak of change of atmospheric conditions and wind. The Battle of Jutland brought out the fact that a large number of shell are required even to hit a ship, and still more would be needed to hit such a target as a shore gun.

In one other point also modern ships are at a greater disadvantage than their predecessors in a contest against shore batteries in the fact that they possess a smaller number of guns. If it be granted that a direct hit is necessary to put a shore gun out of action then the more guns which are available to fire at it the greater the chance of hitting. During the World War a number of British monitors were built and used for bombarding

the German batteries on the Belgian coast. While they possessed many advantages in their design which tended to render them less vulnerable, they had the grave disadvantage of an armament small in number.

Except in special cases ships are built to fight other ships and not to fight coast batteries, and it would seem to be admitted now that naval fire can never be effective against such small targets, and that it is better to reserve it, in action against the shore, for firing upon areas such as docks or dockyards.

If a fleet was determined, regardless of loss, to come to really close quarters with coast defences, some of the advantages of the shore gun would undoubtedly be minimized. But the superiority of the land range-finder would render such an operation in day-time extremely hazardous to the fleet, apart from any action by submarines on the part of the defender, while at night it is difficult to see what object could be attained, apart from such a special attack as was carried out at Zeebrugge.

Very many actions have been fought between ships and batteries, and a few of the most instructive may be mentioned here.

At Eckernförde in April 1849 a Danish fleet consisting of one battleship, three lighter vessels and two steam gunboats attacked the Prussian defences, which comprised two batteries containing two 8-in. guns, two 24-prs. and six 18-prs., assisted by one field battery and three battalions of infantry. The batteries were near the water's edge on low sites. After a long action at short ranges, the battleship and one frigate surrendered and the remaining ships retired, all having suffered severely. The casualties in the batteries were one gun temporarily disabled and ten men.

One of the most instructive instances in the past was the naval attack on Sevastopol in 1854. There the British in-shore squadrons of five large ships engaged three works—Fort Constantine, a large masonry-casemated fort with barbette guns on the top, which rose from the sea at the mouth of the harbour; a small brick fort called the Wasp battery, on a cliff 110 ft. high; and the Telegraph battery, an earthen one on the same cliff, the two latter works having five guns each on the sea front.

From a range of 800 yd. 22 out of the 27 barbette guns of Fort Constantine were silenced in a very short time by the fire of three ships, the splinters from the stone walls causing a great deal of damage. But the other two batteries caused the retirement of the whole squadron with considerable loss, while they themselves suffered very little, the Wasp battery having one gun upset and 22 men wounded while the Telegraph sustained no loss at all.

In the action at Alexandria in 1882 the conditions were almost wholly in favour of the ships, namely, smooth water, works not only on very low sites close to the water but badly designed, a poor armament and inexperienced gunners; yet the shooting of the ships had little real effect, and against better troops the fleet would hardly have gained its object. This was due, no doubt, principally to the nature of the naval armament, which consisted to a very large extent of slow-shooting heavy guns, few in number, while the shore guns were well dispersed.

When the World War began it was sometimes argued, as it had been argued in past periods, that present-day naval artillery is so powerful that it would reverse the lessons of the past. But the experiences of the war have only emphasized those of its predecessors.

A long series of engagements took place between British ships and the batteries erected by the Germans on the Belgian coast. The number of these actions was at least 40, and yet no gun, mounting or magazine of these numerous batteries was ever hit.

In the naval operations in the Dardanelles, on March 18 1915, a deliberate attack was made on the main batteries of the defence near the Narrows by 16 battleships, at the comparatively short ranges of from 10,000 to 14,000 yards. The Turkish batteries and guns were old, the works were badly sited, as a rule close to the water, and their high traverses rendered them very conspicuous. At the end of the day three battleships had been sunk by mines and three others so badly damaged by shell-fire as to necessitate immediate withdrawal to a dockyard.

The damage to the batteries was very small. For instance, the old Hamid-i-I. battery near Chanak, which contained three 14-in. and six 9.2-in. guns, had one of the latter put out of action and suffered some losses in its garrison. A war-time battery of five 6-in. guns at Dardanos, near the top of a conspicuous hill some 150 ft. high, received a large amount of attention, but the only result was that three gun-shields were dented by splinters.

A general summary having been given of the conditions of the combat between ships and shore batteries in the past, the point next to be considered is what are the objects to be attained by coast defences to-day.

In order that the navy shall be free to carry out its true function of attacking the enemy's naval forces and keeping clear the ocean lines of communication of the country, it must not be

hampered by having to think of guarding its own bases against any attack likely to be made on them. If it had to do this its mobility would be lost. Naval bases, where ships can renew their fuel supplies, ammunition and stores of all sorts, and where they can repair damage, must be self-protected. Similarly, it is advantageous that certain commercial ports where a country receives large overseas traffic or where convoys are assembled for dispatch should be self-protected. Also, for strategical reasons certain harbours should be self-protected, where naval squadrons can lie at ease without jeopardizing their own safety or risk being caught like rats in a trap.

It is at parts of the above description that "coast defences" find their real use, and while, as stated above, such defences should be kept down to a minimum, they must be capable of doing their protective work effectively. The necessary scale of defence will vary with every nation; and, with the far-flung possessions of the British Empire and any country with overseas dependencies, the requirements will vary in every case. Many factors must be taken into account. The strength of the naval forces of the country in question, the strength of the naval forces of any possible enemy, the geographical position of the harbour in consideration with respect to the enemy and with respect to the main forces of the country to which it belongs—all these points must be duly weighed in deciding on the scale of defences to be adopted, as well as the particular rôle which the harbour is intended to fill in the general fighting scheme.

Fixed defences may be said then to form a part of the scheme for utilizing the naval forces of a country, and it has been argued that these defences should be manned and controlled by the navy. In a few countries this is the practice, but in the majority it is not, and it would seem that the latter are right for the following reasons: the service and control of artillery afloat differs greatly from those of artillery in coast batteries; the use of artillery in such batteries is not very different from that in heavy batteries in land warfare. Therefore it would seem advisable to have coast batteries manned by land gunners and not by naval gunners. History has shown that the defences on the land side of a coast fortress are often the door by which an enemy seeks to enter, e.g. Sevastopol, Port Arthur, Tsingtao, and the Dardanelles in the World War. These land defences are very intimately connected with the fixed coast defences and also with the field land forces, which must form a part of the army and not of the navy. It is evident then that in the general scheme of defence of a defended port there must be some line of demarcation between naval and military control, involving the closest co-operation between the two wherever that line of demarcation is drawn. For these reasons alone it is argued that the proper line of demarcation should be that provided by nature, namely, the edge of the sea.

*Adaption of Coast Defences to Local Conditions.*—While coast defences will vary according to the scale on which they are based, they will also vary according to the local conditions of the place to which they are applied. These local conditions, apart from topographical considerations, fall into three main classes: (1) Defence of a harbour; (2) Defence of a channel; (3) Defence of a landing place. The greater number of cases will come within the first class.

(1) *Defence of a Harbour.*—This may be a naval port, a commercial harbour or a strategical anchorage. The scale having been determined upon, the coast defences necessary will depend upon the different forms of attack to which the harbour may be exposed. Attack on the land side of the harbour by forces landed outside its rayon is omitted here, as it is a branch of land warfare and is dealt with elsewhere. It is sufficient to remark that in the past this has often been the most effective form of attack on a defended harbour. With this omission it may be said that the forms of attack are: (a) Bombardment; (b) Attempts to block narrow parts of the approach channel by sinking ships in the fairway and so sealing up the harbour; (c) Close attack by small torpedo craft on ships or dockages, probably at night.

(a) *Bombardment.*—This form of attack may be taken to include not only bombardment of the object for which the har-

bour exists, such as a dockyard or anchorage, but also action, analogous to counter-battery in land warfare, against the batteries protecting the harbour, as in the event of bombardment these batteries naturally come into play. The positions of these batteries will largely depend upon the topography of the environs. There are two general types of harbours, namely, one with an approach channel, which may be either long or short and broad or narrow, or one where the coast-line is to all intents a straight line, the harbour being formed by a slight indentation of the coast, or by artificial breakwaters.

Whenever possible the batteries should be pushed out as far as may be from the real object of defence. This has always been advisable, but in these days it is more than ever necessary. The fact must be faced that with the present long ranges a larger amount of ammunition will be necessary than previously to obtain hits on hostile vessels. This means expenditure of time, during which the vessels may be able to shell the area forming their point of attack and inflict damage.

It may be taken now that bombardment can take place from such distances as 50,000 or even 60,000 yd., and across intervening portions of land. If at all possible then the primary batteries should be pushed so far forward that they can keep ships beyond this distance, or be so far forward that they will bring an effective fire to bear on the ships at much less than extreme ranges, before the latter come within bombarding range.

This, however, is not always possible, and in the event of a straight coast-line the enemy will be practically equidistant from the batteries and from the object of their defence. This will undoubtedly be a great disadvantage to the batteries, and the number of guns will have to be greater than usual in order to occupy fully the attention of the hostile vessels.

In the past, when the range of artillery was shorter, it was sometimes necessary to construct forts in the sea itself in order to cover effectually the whole of a broad channel, e.g. Spithead, Kronstadt or the entrance to Tokyo Bay. Nowadays, however, this will practically never be necessary.

The experiences of the World War have shown that the number of guns required to defend a harbour is even less than it used to be. Enemy ships for one thing will be chary of approaching too close on account of mines, submarines and electrically controlled torpedo craft, and the great superiority of modern land range-finders over ship range-finders will ensure greater accuracy on the part of the shore guns. These latter should be well dispersed and should be able at the same time to concentrate their fire. Batteries with single guns would have their advantages, but there would always be the chance of a lucky hit from the sea putting the gun out of action and so silencing the fire from a portion of the defence. It is probable then that there will be always two guns in a battery, but they will be well separated by about 200 yd. or even more.

*Form of Batteries.*—The form that batteries will take will undoubtedly be influenced by the lessons of the war. Taking into consideration the long ranges in use and the dislike of ships to come close in, there are many advantages to be gained by making primary batteries into indirect-fire batteries, siting them where they will be unseen from the sea and controlling their fire at all times by some system of position-finding. The advantages so gained would be, increased protection from hostile fire, much greater latitude in the choice of sites, a great simplification in design due to the protection the battery gains from its position and probably easier communications up to the battery. The disadvantages are, loss of range, a certain area of dead water in the foreground of the battery, and the impossibility of fighting the guns in the event of the means of control of fire breaking down. The loss of range would be unavoidable but the amount would be small. The area of dead water would depend upon the topography of the coastal region (it is always assumed that the dead water is navigable). In very many cases it can be covered by the fire from another primary battery. Should this not be the case it might be necessary to install a direct-fire battery *ad hoc*, which possibly might be able also to fulfil one of the duties of secondary batteries, or to use mobile howitzers to cover the area. As regards the third disadvantage, adequate protection for the communications of the fire-control system, together possibly with its duplication, would seem to reduce the contingency of this breakdown to a negligible point.

All the primary batteries erected by the Germans on the Belgian coast were for indirect-fire. After the evacuation by the Allies of

the Gallipoli Peninsula the Germans commenced the construction of an indirect-fire battery inland from Cape Helles, which was not quite finished at the end of the war, while at the Black Sea entrance of the Bosphorus on the European side there was a battery constructed by the Germans which was sited (designedly or not) in a peculiarly clever manner. It was near Rumeli Fenner and contained three 24-cm. guns. Owing to the configuration of the ground it was an indirect-fire battery if used against ships in the Black Sea to the west of the Bosphorus, while in the event of vessels trying to force the entrance the guns could use direct fire at a comparatively short range.

**Site of Guns.**—There is a certain amount of disagreement as regards the size of guns required in coast batteries. In the case of a straight coast-line the guns must be powerful enough and possess sufficient range to engage and cause the retirement of the ships, or at all events to make them confine their efforts to replying to the batteries. This means that they must be equal in ranging power to the guns of the enemy.

When an approach channel exists, however, and the batteries can be pushed forward, it is not really necessary that the coast guns should be as long-ranging as those of the ships. They only require to have sufficient range to enable them to bring effective fire on the ships before they come within bombarding range of the object of attack. To obtain long range it is also not really essential to have guns of very large calibre, although the life of a large gun is certainly longer than that of a smaller one of equal range. Naturally, the shell fired by a coast gun must have a real effect on a ship. But at the range at which actions are now fought the angle of descent is so great that the deck is more often than not the place where a hit would take place, and the protection in this part of a ship is not very great. On the Belgian coast the Germans had five 15-in. guns (38-cm.), four 12-in., and a number of 11-in., but it seems questionable whether, provided sufficient range can be economically obtained, a gun of 11-in. or possibly 12-in. would not be quite powerful enough for a coast battery against any kind of vessel. As already stated, it is necessary to reduce to a minimum the amount of material and number of men employed in coast defences, and the smaller the gun the greater the economy in both.

It has often been advocated that guns on railway mountings should be used for coast defence, and at first sight they appear to be advantageous. They can be moved comparatively easily from place to place in accordance with strategic requirements. But the ordinary railway heavy-gun mounting is not suited for use against ships since it does not give sufficient traverse, as it can be fired only a few degrees on either side of the axis of the railway. Ships are moving targets and coast guns must have a very large arc of fire. For considerable variations in the line of fire a railway gun has to be on a curve of the line and move along the curve as required. This is too slow for use against a moving target. From the point of view of protection the faculty of being able to be moved is hardly required, especially if the gun is firing indirectly. There may be strategic advantages however in having movable coast guns, designing the mountings so that they can be moved on rails and can also be transferred in a fairly short time from their travelling wheels on to prepared pivots.

**Range-finding.**—For the modern coast-defence gun it is essential that the best possible means of range-finding be employed. Many instruments have been used for the purpose. Some are adapted to give only the range of a target from the site of the range-finder, others termed position-finders give the actual position of the target on a chart of suitable scale and therefore its relation to the gun position, which is also marked on the chart.

Both range-finders and position-finders are of different kinds. Some depend on a vertical base and so require correction for tide level. Others depend upon a horizontal base and therefore must be in pairs, one at each end of it. In this case one is known as the transmitting instrument and the other as the receiving, the latter being near the gun. In a different class again is the self-contained range-finder, in which telescopes at either end of a tube from 3 to 33 ft. long, furnished with prisms, conduct the visual rays to central object-glasses—telescopes and object-glasses being so controlled by mechanism that when the two images of the target are in a certain definite agreement the range is marked mechanically.

The long ranges now required practically put out of court all instruments except those depending on a horizontal base, which must be sufficiently long to obtain intersections at the target that are not too acute. There are two classes of this system, one in which the receiving instrument itself combines the observations of the two and the results are automatically recorded on dials at the gun, the other in which the observations of both instruments are combined graphically at a central plotting station and the range and training are telephoned to the battery. The former system has the advantage of using fewer operators than the latter, but it requires more elaborate instruments and a larger number of electric circuits. The latter system is hardly any slower than the former, and its communications consist of telephones only. It is possibly the one best suited to conditions of active service.

The chambers required for the angle-measuring instruments are quite small, and though they must be in direct view of the sea they can easily be made very inconspicuous. The receiving instrument

should be somewhere near the battery; if an indirect-fire battery it should be nearly straight in front of it. For economy, principally, it is customary for one pair of instruments to suffice for all the guns of a battery, one gun being selected as the "master," and the other guns are laid by previously worked-out corrections (known as group differences) upon the training of the master gun.

In order that the instruments can have sufficient range of vision it is necessary that they should be at a considerable height above sea-level. This is not always easy of attainment on a low-lying coast. In order to see the horizon at 50,000 yd. an observer must be a little more than 450 ft. above sea-level. But for coast-defence purposes a lesser height would serve, as the target ship will have some height above horizon. For instance, the records of a minor engagement between a German 11-in. battery near Blankenberge, Belgium, and one or two British ships, showed the greatest range used by the battery was 27,000 yards. The instrumental system was a long-base position-finding one. The base was 9,445 yd., the receiving instrument was 110 ft. above sea-level, on the top of an hotel, and the transmitter was on the top of a house on the dunes, the instrument being 90 ft. above sea-level. This latter height has a sea horizon of 22,000 yd., but the battery was 1,750 yd. back from the sea. Thus the transmitter was laid on a target more than a mile beyond its sea horizon.

The Germans made great use of the tall buildings on the Belgian coast for their observing instruments, but it may be necessary to erect towers to obtain the requisite height.

The question of visibility is a very important one in the matter of range-finding, especially in such a climate as that of Great Britain. There are many days on the British coasts when a view of anything like 50,000 yd. is impossible, owing to sea fogs. Such are often low-lying, and it might be possible to overcome them by the use of captive balloons. Another means of correcting fire is the employment of aircraft, which may be used by both sides in the contest. Here length of range is immaterial, but the accuracy of observation is naturally less than that from instruments.

Self-contained instruments (such as the Barr and Stroud and the Zeiss) have been mentioned above. These are range-finders only. They were supplied in large number to the German batteries on the Belgian coast, but the records show that they were not relied on for long ranges, but regarded as stand-bys in the event of anything happening to the long-base system.

**Design of Batteries.**—The experiences of the World War show that the battery of the future can be greatly simplified. No longer need it be regarded as a fort, and the fact can be frankly accepted that the chances of damage by hostile naval fire are extremely low; the batteries may be designed accordingly. The guns require their stable platforms of concrete, but parapets are not necessary. Ammunition can be stored in light weather-proof structures or in covered railway wagons on a feeding railway, protection being sought by dispersion rather than by thickness of covering. The supply of ammunition to the guns must naturally be made as easy as possible, and great use can be made of light railways.

This type of battery was used by the Germans in Belgium in the later stages of the war. At first these batteries were all of the type in use before the war, with heavy concrete and earth protection over the magazines. But after their experience of many bombardments they practically abandoned all material protection. Also, while the earlier range-finding stations had thick concrete protection the later structures were weather-proof only.

**Effect of Aircraft.**—The war has introduced a new arm which cannot be ignored in any branch of the military art, namely, the air service. As already mentioned, aircraft can and will be used for correcting the fire both of ships and of coast batteries. But it is also necessary to consider the offensive action of aircraft against batteries. Unless the aircraft can descend low enough to make use of machine-gun fire this action will consist of bomb-dropping. The use of bombs is very similar to the use of long-range large shell, and, at all events up to the present, it is extremely difficult with bombs to obtain any accuracy against small targets.

A coast-battery gun emplacement may be taken to be about 120 yd. in diameter. If an aeroplane were travelling at a speed of 120 m.p.h., in order to get a direct hit on such a target the bomb must be released at an exact fifth of a second, the plane must be flying exactly across the emplacement, and there must be no wind at all, or at all events no variation in the wind, during the descent of the bomb. All these conditions are very difficult to fulfil conjointly, but practically only direct hits will put the gun out of action. It would also be quite easy to erect vertical splinter-proof protection round an emplacement to guard against approximate hits, although this has the disadvantage of making it more conspicuous to the eye of an aerial observer. Efficient overhead cover for the guns is almost impossible to provide, and is not really required.

It would probably be advisable to furnish some material protection for the gun detachments when not in action, as the explosion of large bombs in close vicinity is a trying experience.

However, the main protection of batteries against aerial attack will lie in the use of counter aircraft and of anti-aircraft guns. Even with the latter only hostile craft will have to keep high up, and the accuracy of their aim will be very greatly impaired. Therefore every battery must be within the rayon of some anti-aircraft guns.

**Direct-Fire Batteries.**—Under certain circumstances it may be impossible to site a primary battery in a position concealed from the sea. It may have to be a direct-fire battery. In this case it should, if possible, be on a high site in order to facilitate fire with automatic sights at short range and also to render it less easy to hit. Since the guns will be visible from the sea, every endeavour must be made to render them as bad targets as possible, by having nothing outstanding in the outline of the battery as seen from the sea. The essential point is that they must have a background. This may exist naturally, but, if not, an artificial background must be provided with an outline in keeping with the vicinity.

As regards ammunition storage it would still seem advisable to adopt the scheme of small dispersed expense stores with tramway communications to the guns, combined with small dumps in or near the gun emplacements for immediate use.

(b) **Blockship Attack.**—Hitherto only the primary batteries have been considered for protection against bombardment, but there are the other possible forms of attack, which necessitate the use of secondary batteries of lighter guns. One of these is attack by blockships in order to seal up a harbour. This is possible only where there is a very narrow channel which is to seaward of the important part of the harbour. For instance, there are the entrances to the harbours of Santiago de Cuba and Port Arthur, and to the Bruges ship canal at Zeebrugge. These were all attacked in modern times; the attempts made by the American and Japanese navies respectively were unsuccessful, while at Zeebrugge the British attack succeeded.

Such attempts would always be made at night, and old warships would often be used for the purpose. This means that the time available for stopping the ships would be very short, and the feat is not to be accomplished easily. But they should be stopped before they reach the bottle-neck of the channel.

The defence guns must have a rapid rate of fire with good shell-power, and the means of illuminating the approaches must be the best possible. It may well be also that, in certain cases, torpedoes fired from the shore would prove effective. The guns need not be of the heaviest calibre; but nothing under a 6-in. gun will be of much use. The idea of protection for these guns requires very little consideration. In the dark there is little chance of direct hits on them, while shrapnel can be guarded against by light gun-shields. Such guns, and all secondary armament, should be direct-fire, with automatic sights.

The successful blocking of the Bruges ship canal on April 23 1918 is an excellent instance of the fact that a fleet, which is determined to come to close quarters with coast defences, will most surely find out any weak spot in the latter. There were weak spots at Zeebrugge. Most of the German guns were sited as if they were meant to defend the water outside the Mole, and none seemed to have been specifically allotted to deal with blockships, although the Germans quite realized the possibility of such a form of attack. The searchlights were sited similarly—there was no concentration of illumination at the spot where the guns could have been certain of hitting. On the other hand the flanks of the canal entrance were crowded with machine-guns, trench mortars and rifles, some machine-guns being only 50 yd. from the final positions of the blockships. These weapons were of no use in stopping the ships, but were admirably placed for killing the crews, who, in leaving the ships, were completely exposed. That the losses amongst the crews of the blockships and the motor-boats were small can only be put down to the theory that "Fortune favours the brave."

(c) **Close Torpedo Attack.**—Another form of close attack is that by small craft such as destroyers, torpedo-boats or motor craft, which would attempt to run in at night and attack ships at anchor inside a harbour, or dockgates, using the torpedo as their main weapon. Here the question of the electric lights (see 6.60z) is of primary importance. To stop such an attack secondary batteries are required. The guns of these batteries will have to possess increased shell-power compared with those previously in use, in order to keep pace with the greater protection and greater speed now given to torpedo craft. This increase of speed gives less time for the shore guns to get in their hits, and therefore it is essential that each shell should have good destructive effect. Wherever possible very low sites should not be used for secondary batteries. A certain height facilitates the use of automatic sights with the guns and favours observation of fire, and the guns are better enabled to see their target in the beams of the electric lights. However, it must be remembered that no dead water is permissible with these batteries, and

that the limit of navigable water is near the shore for light craft than for larger ships. Therefore, there are limits to the height at which secondary batteries should be placed, taking into account the angle of depression obtainable with the guns.

With an illuminated area of water it is generally not possible to bring an effective fire on torpedo craft at a greater range than 1,000 yd., at which range a height of 40 ft. is sufficient to allow automatic sights to be used effectively. While foggy weather would probably interfere with an attack of this nature some craft might try to take advantage of the obscuration of the lights and creep in. In such a case sound-ranging, especially sub-aqueous, a new method of position-finding produced by the war, could be profitably employed to ascertain the position of any such craft and allow a fairly accurate fire to be developed against it.

It seems probable, however, that modern conditions will render this form of attack less likely in the future than it was thought to be in the past. Still another form of it may have to be taken into account should the use of torpedoes from aircraft attain the success which its advocates prophesy. Here the direction of approach of the enemy is not limited to a navigable channel, as the aircraft may descend from any quarter of the heavens. The defence against this modern phase is practically the general case of defence against any aircraft, except that the planes should be attacked as soon as possible before they have a chance to release their torpedoes. Also, they will be most likely to effect this release where their torpedoes have a fair run in the water against their targets.

(2) **Defence of a Channel.**—Here the word channel is meant to imply a comparatively narrow stretch of water which has open or nearly open water at either end, the passage of which it is desired to bar to an enemy. Such channels as the Straits of Messina, the Straits of Shimonoseki, the Dardanelles and the Bosphorus would come within the meaning. Also it may be taken to include harbours having a long channel of approach and a wide stretch of water inside the channel.

A fair number of cases in which such channels have been fortified and attacked have occurred in history. Not so far back, in 1807, a British squadron under sail forced the Dardanelles in spite of the batteries. In this case and in similar cases in the past the outstanding feature has been that gun-fire alone has not been able to stop the passage of a determined fleet, where the ships have been able to pursue their course unhindered by obstacles and where they could finally gain water unswept by gun-fire. Perhaps the most striking instance of such an operation was the passage of the Federal squadron under Farragut at Vicksburg on the Mississippi in 1863. The ships were slow and the current was swift, the navigation was not easy, the range was short and the guns were well-sited. But the squadron passed the town not once but several times. The defenders relied on their batteries only, no obstacles being placed in the river.

The World War produced a notable instance of this class of operation in the attempts of the British and French fleets to force the passage of the Dardanelles. Here the current is swift but the ships had greater speed than those of 1863. The Turkish batteries were certainly numerous but the guns were not up to date, and the batteries were generally badly sited and designed. But the Turks did not depend upon their guns only; they made extensive use of obstacles in the shape of submarine mines.

A desultory bombardment took place on Nov. 3 1914, but the real attack did not begin till Feb. 19 1915. The entrance to the Straits was gained and operations continued inside, culminating in the great attack on the main batteries near the Narrows on March 18 1915. In his despatches the British admiral states that the withdrawal of the ships was due to the menace of the mines. It may be said that the backbone of the defence was the minefields. Until they were removed the ships were hampered in their movements and could not deal properly with the batteries protecting the minefields; also the ships could not remove the mines until the protecting batteries were silenced. The attack of March 18 was not repeated.

It is possible and even probable that if the Turkish batteries had been of a modern pattern and had possessed proper ranging appliances (the Germans added these afterwards), the shore guns might have played a larger part than they did, and this point should be remembered should similar operations take

place in the future. If the ships are intent on forcing a channel ranges will naturally become short and the fire of the shore guns will become very accurate. The small battery at Hartlepool which fought the German squadron on Dec. 16 1914 undoubtedly left its mark on the enemy vessels.

The outstanding lesson of the naval operations in the Dardanelles would seem to be a very old one—that men are more than material, that even moderately armed and organized defences, when manned by stout-hearted troops, as the Turks undoubtedly were, although not well trained technically, can still have in them a very great power of resistance, provided the tactical organization of the defence is not radically unsound.

It has been mentioned with reference to the Dardanelles that minefields may play an important part in the defence of a channel. Such minefields, although they may, by the active power of the mines, do great damage to a ship which strikes one, may be removed by sweeping or countermining, and really form an "obstacle" in the military sense of the word which to be effective must be protected by fire. It will therefore be necessary to arrange that minefields are under the effective fire of batteries. The guns of such batteries would probably be about the same size as those for dealing with torpedo craft, as the vessels used in attempts to remove mines will not be large. If possible minefield batteries should be so sited that they are protected from the fire of the larger hostile ships. This was done at the Dardanelles by taking advantage of the projecting points of land on both the European and Asiatic shores. As mine-sweeping would generally take place at night electric lights must be provided specially for the use of the minefield batteries.

(3) *Defence of a Landing-Place.*—In certain cases it may be necessary to prepare defences against the chance of an enemy landing on a stretch of coast. It would rarely be possible to hold such a line in any strength, nor would such a course be desirable, as it would mean locking up troops for an indefinite period, while it is hardly likely that no warning of a possible landing would be received. Suitable defences can play an important part by enabling small bodies of men to hold up an attack until reinforcements arrive, but for deliberate preparations to defend all possible landing-places the expenditure of men and materials will always be prohibitive. Such measures can be taken only in the case of very important places.

The line of coast to be dealt with may or may not lie within the rayon of a coast fortress. If it does there may be some guns of the fortress capable of bearing on the water in front of the shore to be defended, and their fire will be of the greatest value against both the covering ships and the boats containing the landing force. The scheme of defence will have to be arranged so as to take full advantage of this fire and not to mask it in any way.

The works of fortification required on the stretch of coast-line will then fall under three heads: (a) defences on the actual coast so designed as to enable the minimum number of men to hold up any probable attack; (b) ample communications of all kinds to allow reinforcements to be sent up as quickly and as safely as possible to the threatened spot; (c) measures to be taken to deal with parties of the enemy who may succeed in effecting a landing and breaking through the defences on the shore.

(a) The nature of the coast-line to be defended will naturally vary in many ways, but, as it forms an assumed landing-place there will always be a beach or strand of some sort, and in all probability the gradient of the slope into the water will not be excessively gentle. It is likely also that in most cases the landing-place will be a bay, with reasonable expectations of higher ground at the extremities of the bay. A long straight coast-line is an unusual case.

The backbone of the scheme of defence on the coast-line itself should consist of the provision of enfilading fire along the shore and the water close to it where the landing parties are expected. To economize men use should be made of all the machine-guns which can be obtained. Advantage must be taken of all promontories in siting these enfilading weapons in order to obtain cover for them from the view, and if possible from the fire, of ships covering the landing, but in any case it should be ensured that all the possible landing beaches are covered by a sufficiency of fire, and this fire should be as grazing as possible. Therefore, the enfilading posts must not be high up above the water.

Should there not be any natural protection for these posts from view from the sea they must be made as inconspicuous as may be,

their outline being blended into their background, and their color corresponding with it. As they will be very low structures this should not prove difficult of accomplishment. It would probably be advisable that the machine-guns should be given splinter-proof cover, the weapons firing through slit loopholes. For deliberate work the actual posts for the machine-guns might well be made of concrete. Their distance apart will vary according to circumstances and ground, but a fair average distance might be taken as half a mile, allowing four enfilading machine-guns to each post.

An effective obstacle along the shore is of the greatest importance. This will usually be barbed wire, and it should extend all along the line to be defended as thick as circumstances will permit. The machine-guns must be able to enfilade the obstacle. If it is possible to erect any wire actually in the water this will greatly assist in impeding a landing and in breaking up the formations of the enemy. But the wire along the shore is the more important, that in the water being considered an addition.

The machine-gun posts should be protected by and should form part of small infantry posts, say for a platoon. These are primarily intended to protect the enfilading guns, and must therefore be prepared for all-round defence. At the same time they should be able to fire over the water and along the shore between them. These works must be quite inconspicuous, but this should not prove difficult to arrange. Each post should be completely surrounded with a wire obstacle, and as they may be shelled by the covering ships it would be well if some deep dug-outs were provided for the garrison. If not, the trenches themselves will give very fair protection.

Trenches actually facing the sea, in the case of a long coast-line, require a large number of men and should be used only sparingly. But it might be well to prepare some of these for occupation by some of the reinforcing troops, although the action of the latter is more likely to take the form of counter-attacking any hostile troops that have succeeded in landing. If such trenches can be enfiladed from the infantry posts so much the better, as then they would be of less value to the enemy should the message to land and seize them before the defence reinforcements arrived.

In addition to any coast batteries that may be available field artillery and trench mortars should be ready to play their part in repelling the attack. These weapons should also, as a rule, be used for enfilading, and emplacements should be prepared for them together with shelters for their ammunition and detachments. Full advantage must be taken of any natural cover to secure protection for them from the fire of the ships.

(b) The provision of ample means of communication for reinforcements must be complete. They will depend on the local conditions, but it must be borne in mind that the covering ships will probably shell these communications and this must be prepared for. Points such as bridges on the line of route, road crossings, etc., must receive special attention in the way of providing alternative routes, and roads exposed to view from the sea should be screened, especially near the shore. Movement along such roads will always be liable to be noticed by hostile aerial observers, but these can be countered only by offensive action of the defending aircraft.

(c) Some works are also necessary to localize any successful attempts at landing. These should be the form of lines running back from the shore ("switches"), starting from one of the infantry posts on the coast. These switches would generally be inclined at an angle to the coast-line. If any coast batteries are included in the area the switches should be utilized to add to their defences, as the capture of such batteries would certainly form one of the objectives of the enemy. The actual work to be executed on these switches would consist mainly in providing a line of wire entanglements, but posts should be prepared at intervals which could cover this wire with their fire. (J. C. M.)

**COATS**, the name of a Scottish family, which established at Paisley the Ferguslie cotton-thread mills, as well as mills in the United States, Canada, Mexico, South America, Russia and other European countries (now J. & P. Coats, Ltd.) and, with the fortune thence acquired, became munificent benefactors of their town (see 20.520). **JAMES COATS** (1803-1845) and **SIR PETER COATS** (1808-1890), first and third sons of James Coats of Paisley, were the founders of the firm. The younger but eldest surviving brother was knighted in 1869, and his eldest son, **SIR JAMES COATS**, 1st bart. (1834-1913), directed the fortunes of J. & P. Coats, especially in Canada and the States, his younger brother, **ARCHIBALD COATS** (1840-1912), being chairman of the company at Paisley. **Sir James Coats** was created a baronet in 1905 and died at Ayr Jan. 20 1913. His son, **SIR STUART AUCHINCLOSS COATS**, 2nd bart. (1868- ), was for a time a member of the old firm and of the associated American and Canadian Thread companies. **PETER COATS** (1842-1913), third son of Sir Peter Coats, and brother of Sir James Coats, another director of the firm, died at Whitney Court, Hereford, Sept. 16 1913. **SIR THOMAS GLEN COATS**, 1st bart. (1846- ), second son of Thomas Coats

of Ferguslie, younger brother of the founders of the firm, assumed by royal licence the surname Glen-Coats when created a baronet in 1894. He succeeded Archibald Coats as chairman of the firm and sat in the House of Commons for W. Renfrewshire from 1906 to 1910. His elder brother, JAMES COATS (1841-1912), was the giver of the Coats libraries, 4,000 of which were sent to villages and schools in Scotland. Each consisted of a bookcase containing about 400 volumes, and the school-children were provided with satchels for carrying the books to and fro. Spectacles to the number of about 90,000 were also supplied under the direction of a qualified oculist, to readers who needed them. Similar libraries were sent to places abroad, such as Smyrna, Cairo, Jerusalem, etc. No endowment was, however, provided, and the libraries, at first much appreciated, fell into disuse. A younger brother, GEORGE COATS (1849-1918), also a director of the firm, was raised to the peerage in 1916 as Baron Glentanar. He died at Glentanar, Aboyne, Aberdeenshire, Nov. 26 1918; and was succeeded by his son, THOMAS COATS (b. 1894).

**COCHERY, GEORGES CHARLES PAUL** (1855-1914), French politician (*see* 6.619), died in Paris Aug. 8 1914.

**CODY, WILLIAM FREDERICK** (1846-1917), American scout and showman (*see* 6.637), died in Denver, Col., Jan. 10 1917. He was buried in a tomb blasted from solid rock on Lookout Mountain, 20 m. from that city.

**COHN, GUSTAV** (1840-1919), German national economist (*see* 6.652), died in Sept. 1919, at Göttingen.

**COLAJANNI, NAPOLEONE** (1847-1921), Italian author and politician, was born at Castrogiovanni (Sicily) in 1847. He followed Garibaldi in his Sicilian expedition, and later at Aspromonte, when he was taken prisoner by the Royal troops and deported to Palmaria. Again in 1866 he fought under Garibaldi in the Trentino and was decorated with a silver medal for valour. Three years later, while a medical student, he was imprisoned for taking part in republican agitation. After graduating in medicine he took up the study of social science, and in 1892 was appointed professor of statistics at the university of Palermo. He published many books and essays on social and political problems, and exposed the fallacious and unscientific theories of Lombroso and Ferri on criminology. For many years he edited the *Rivista popolare*, by means of which he strove to improve the moral and intellectual standard of the masses and combated all forms of intolerance and hypocrisy. He began his public career as a municipal councillor in his native town in 1872; in 1883 he was elected provincial councillor and in 1890 deputy for the same place. In Parliament he sat as a Republican and showed Socialist tendencies. He was active in the exposure of the Banca Romana scandal, and a strong opponent of Crispi's somewhat autocratic tendencies. While he had always opposed militarism and had also attacked the army with much animus, on the outbreak of the World War he admitted his error in that connexion and became a warm supporter of Italian intervention. After the Armistice he conducted a vigorous campaign against the Socialist organ *Avanti* and the bolshevist tendencies of the Italian Socialist party. He died at Castrogiovanni Sept. 2 1921.

**COLBY, BAINBRIDGE** (1869- ), American politician, was born at St. Louis Dec. 22 1869. After graduating from Williams College in 1890, he studied at the Columbia Law School and the New York Law School. He began to practise in 1892 in New York. He was counsel for Mark Twain in settling the affairs of the publishing house of Chas. L. Webster & Co. He was a member of the New York Assembly, 1901-2. He was an ardent supporter of the candidacy of Theodore Roosevelt for the Republican presidential nomination in 1912, and was in charge of the contests for seating the Roosevelt delegates in the national convention. Following the split in the Republican party he became one of the founders of the National Progressive party and was a delegate at its national convention in Chicago in 1912. He was an unsuccessful candidate for the U.S. Senate from New York on this party's ticket in 1914 and 1916. He was appointed a commissioner of the U.S. Shipping Board, and a member of the U.S. Shipping Board Emergency Fleet Corp. 1917-9. He was likewise a member of the American mission

to the Inter-Affied Conference at Paris in 1917. In Feb. 1920 he was appointed Secretary of State to succeed Robert L. Lansing by President Wilson, to whose administration he had given his support.

**COLERIDGE-TAYLOR, SAMUEL** (1875-1912), British musical composer, was of Anglo-African parentage, his father being a native of Sierra Leone and his mother an Englishwoman. He was educated at the Royal College of Music in London, entering as a violinist in 1891. In 1893 he won an open scholarship for composition, and studied for four years under Sir Charles Stanford. In 1898 his cantata, *Hiawatha's Wedding Feast*, was produced in London with marked success, and was followed by two other cantatas, *The Death of Minnehaha* and *The Departure of Hiawatha* (*see* 19.85). This trilogy was first given complete at the Albert Hall, London, in 1900. *The Blind Girl of Castel Cuëllid* was given at Leeds in 1901, *Mog Blane* at Sheffield in 1902, and an oratorio, *The Atoneant*, at Hereford in 1903. He also produced *Endymion's Dream* and the *Bon-Bon* suite (1908-9), and *A Tale of Old Japan* (1911). He died at Croydon Sept. 1 1912.

**COLCUTT, THOMAS EDWARD** (1840- ), English architect, was born March 16 1840. After a pupillage with R. W. Armstrong, he entered the office of G. E. Street, where he remained as chief assistant for three years. The time spent under so strong and impressing an influence had, however, little effect on his own work and design in the future, which never went along Gothic lines, but always spoke his own predilection for a free and personal treatment of Renaissance work—owing more, perhaps, to French than to Italian suggestion. To this method he was, throughout his career, strongly attached, and his designs, shaped on these lines yet speaking his own individuality, had a pronounced influence on the current work of the English architects of the last quarter of the 19th century. It was at the beginning of this period that Colcutt made himself felt in helping forward the movement to which at the same time William Morris was devoting himself—for a highly raised standard in the consideration of the interior treatment and furniture of the English house. Under, and for, the then well-known firm of Collinson & Lock he carried out the decorative work to, and furniture for, many houses in various parts of the country, a preparation of value to him at a somewhat later period when he was one of the first artists to be asked to help in a worthier treatment of the interior decoration of the ships of the large steamship companies. In this capacity he dealt with a considerable number of the P. and O. steamships. It was in 1872 that T. E. Colcutt carried out his first important building—the free library at Blackburn, the commission for which he obtained, as was the case with much of his subsequent work, by a spirited and brilliant design which was successful in a large competition. The even more important town hall in Wakefield, obtained in the same manner, followed a few years later, and is an example of Colcutt's skill in arrangement of plan. His most noteworthy building, however, is the Imperial Institute, London, founded in 1886 by King Edward VII., then Prince of Wales, as a national memorial of the jubilee of his mother's reign. The new building faces on a road formed across the site of the Horticultural Gardens, the whole of the area of which it occupies, and its free and open position, thus obtained, gives it an advantage uncommon amongst modern London buildings. Its elevational treatment speaks the grace and refinement characteristic of the architect's work, and of his usual suggestion of verticality by means of non-ordered pilasters the whole height of the building. Its style is of a free Renaissance type, with details such as cornices and strings perhaps, as some critics say, on somewhat too small and delicate a scale. It nevertheless stands out as a successful achievement in modern English architecture, and one upon which the artist's signature is clearly written. With very much the same character and feeling Colcutt designed the Royal opera house, London—later known as the Palace theatre—making much use of marble and alabaster as decorative material for the interior, and later on he carried out the Savoy hotel, another instance of his careful plan arrangement. He was elected a president of the Royal Institute of



British Architects in 1906; he received that society's gold medal in 1902, and three years earlier was awarded the Grand Prix for architecture in connexion with his artistic services at the Paris Exhibition.

**COLLIER, PRICE** (1860-1913), American writer, was born at Davenport, Iowa, May 25 1860. He lived, while a boy, in Switzerland and England. After studying at Leipzig and at the Harvard Divinity School (B.D. 1882) he became a Unitarian clergyman, but retired from the ministry in 1891. He is best known for his clever sketches of national character in *America and the Americans from the French Point of View* (1896); *England and the English from an American Point of View* (1909); *The West in the East from an American Point of View* (1911) and *Germany and the Germans from an American Point of View* (1913). He died on the island of Fünen, in the Baltic Sea, Nov. 3 1913.

**COLLINGS, JESSE** (1831-1920), British politician, was born at Littleham, Exmouth, Devon., Jan. 9 1831. He was partly educated at home, and also at Church House school, Stoke, near Plymouth. In 1866 he settled in Birmingham, where he founded the mercantile firm of Collings & Wallis, and had a highly successful business career. Entering municipal life, he was intimately associated with Joseph Chamberlain, whose devoted henchman he became. In 1878 he was elected mayor of Birmingham, and in 1879 retired from business. In 1880 he was elected as Liberal M.P. for Ipswich, and during this period became prominent as an advocate of the Radical land policy, known as "three acres and a cow." In Dec. 1885 Lord Salisbury's Government was defeated on an amendment to the Address concerning this policy, moved by Mr. Collings. In 1886 he entered the Liberal Government as parliamentary secretary to the Local Government Board, but resigned with Chamberlain over Gladstone's Home Rule policy. The same year he successfully contested the Bordesley division of Birmingham as a Liberal-Unionist. In 1895, on the appointment of Chamberlain to the position of Colonial Secretary in the Unionist Government, Collings became under-secretary to the Home Office, retaining the post until 1902. He resigned his seat in Parliament in 1918. He was always interested in agricultural affairs, and was the founder (1872) of the Rural Labourers' League and also of the Exminster industrial school. In 1906 he published *Land Reform*, in 1914 *The Colonisation of Rural Britain*, and his *Autobiography*, written in conjunction with Sir J. L. Green, appeared in 1920. He died at Edgbaston, Birmingham, Nov. 20 1920.

**COLLINS OF KENSINGTON, RICHARD HENN COLLINS, BARON** (1842-1911), English jurist and lord of appeal, was born in Dublin Jan. 1 1842, and educated at Trinity College, Dublin, and Downing College, Cambridge. He was called to the English bar in 1867 and joined the northern circuit. He edited the 7th, 8th and 9th editions of Smith's *Leading Cases*, was made a Q.C. in 1883 and a judge in 1891. In 1897 he became a judge of appeal and a privy councillor, in 1901 Master of the Rolls, and in 1907 a lord of appeal (resigning in 1910). In 1899 he represented Great Britain on the tribunal appointed to arbitrate in the boundary dispute between British Guiana and Venezuela; and in 1904 he was chairman of the commission which investigated the case of Adolf Beck (see 14,287) and resulted in his conviction being annulled. Lord Collins died at Hove Jan. 3 1911.

**COLLYER, ROBERT** (1823-1912), American divine (see 6,694), died in New York City Nov. 30 1912.

**COLOMBIA** (see 6,700).—According to the census of 1912, the South American republic of Colombia (excluding Panama) had a pop. of 5,072,604, living in 14 departments, two territories (*intendancias*) and seven special districts (*comisarias*).

Significant modifications of the constitution of 1886 were made by the Congress of Colombia in 1910. A law enacted on June 6 provided that, in case of a vacancy in the presidency, two persons selected by Congress were temporarily to exercise the powers of the president in a designated order. If Congress did not select any substitute, then the members of the president's Cabinet were to assume the powers of the president in an order to be designated by law. The presidential office was declared to be vacant in case of the president's death, the acceptance of his resignation, or

his demotion by judicial sentence. The Senate was given the right to determine when the president was permanently incapacitated to perform his duties or when he had abandoned his post. On Oct. 31 1910, another law was enacted that made important constitutional amendments, among which was a provision that only male citizens who were able to read and write, and either owned real estate, or had an income, should be allowed to vote in congressional and presidential elections. Capital punishment was prohibited. The president's term of office was limited to four years. Senators were to be chosen by assemblies in the respective departments. The Supreme Court was granted the right to determine whether or not a law should be enforced which the national Government or a citizen had denounced as unconstitutional. During the administration of President Concha (1914-8), Congress enacted a law providing for the re-establishment of the Council of State which was to be composed of eight members, namely, the first *designado* and seven members to be appointed according to law. This council was to act as an advisory body to the president.

**Communications**.—European steamship service to Caribbean ports of Colombia was much disturbed by the World War, but later was largely reestablished. Early in 1914 wireless stations were in operation at Cartagena, Santa Marta, and San Andrés. Communications with the United States were much improved by the service of the United Fruit Co. with vessels touching at Cartagena, Puerto Colombia, and Santa Marta. Measures were taken by Colombia to promote good roads. In 1920 the total railway mileage was not quite 800 miles. Various short railway lines were at the time either projected or under construction. From Puerto Wilkes a railway eastward was begun, designed ultimately to reach Bucaramanga. Plans were laid for the extension of the Pacific railway on the north to Cartago and on the south to Carchi. The Northern railway was built from Bogotá to Nemocon and plans were made to extend it to the lower Magdalena river via Chiquiquirá. Puerto Berrio and Medellín were connected by rail. An extension of the Araucaplumas and La Dorada railway to Giradot was being considered, and one through the department of Caldas toward Pereira was being built. The great artery of interior traffic remained the Magdalena river.

**Foreign Commerce**.—In 1910 the foreign commerce of Colombia totalled 35,008,191 pesos de oro (nominal value \$0.973 or approximately one-fifth part of £1 sterling); in 1913 it totalled 62,851,023 and in 1915 49,419,481. According to official statistics the total value of Colombia's imports for 1916 amounted to 29,660,206.16 pesos de oro; while her exports came to 36,006,821.16 pesos de oro. Her most important imports were roughly classified in pesos de oro as follows:—Textiles, 13,476,932.37; provisions, salt, etc., 2,436,578.78; metals, 2,240,845.86; drugs and medicines, 1,346,516.33; paper, etc., 913,502.97; agricultural and mining implements, 830,622; lighting and fuel, 681,816.98; liquors, 666,351.33; oils and greases, 242,450.

During the war there was a great increase of commerce with the United States. In 1916 more than 50% of Colombia's imports were from that country; 28% were from England; about 3% from France; and 3% from Spain. Her exports were classified as follows:—Vegetable products, 22,801,094.51; mineral products, 7,289,070.34; animal products, 4,127,179.72; manufactured articles, 1,173,158.81; live stock, 521,905.58; money, 68,443.80; miscellaneous, 25,968.40. In 1916 over 85-13% of Colombia's exports went to the United States; 7.35% to Venezuela; 1.8% to England; 1.53% to Panama; 1.03% to France and 0.90% to the Dutch Antilles.

**Army and Navy**.—A law of 1916 fixed the size of the standing army at 6,000 men, artillery, engineers and infantry. In time of war it was not in active service might be summoned to the colours. It was estimated that the army could thus be swelled to 120,000 men. In 1920 a decree was issued which fixed the period of obligatory service for infantry at 15 months; for cavalry and artillery at 18 months; and for railway engineers at 24 months. The navy in 1921 was composed of a few small cruisers, gunboats and other vessels. Steps had been taken to establish a military aviation school.

**Education**.—Primary education was free but not compulsory for children between the ages of 7 and 14. It was in charge of and supported by the departments except in Bogotá where it was maintained by the national Government. The census of 1912 indicated that some 50% of the population of the republic was illiterate. In 1916, according to figures of the Minister of Public Instruction, there were in Colombia 5,387 primary schools. The total attendance at primary schools, both public and private, was 347,985. Secondary education was in charge of the Minister of Public Instruction who was assisted by an inspector in each department. In 1916 there were in Colombia 401 institutions, public and private, where secondary and professional training was given to both sexes. The total of primary, secondary and professional educational institutions, public and clerical for both sexes in Colombia in 1916 reached 5,839, and the total attendance 344,089. The chief

institution of higher education was the National University at the capital, which in 1920 was composed of four colleges one of philosophy and letters (*Colegio del Rosario*), one of medicine and natural science, one of mathematics and civil engineering, and one of law and political science.

**Finances.**—In 1911 and 1913 Colombia contracted new foreign loans aggregating some \$1,800,000 and bearing interest at 6%. The budget for 1920 estimated the total revenue at 23,845,250 pesos de oro; and the expenditures at 27,792,581.37 pesos de oro. In his message to Congress, July 20 1920, President Fidel Suárez estimated that the revenues for the current year might reach 24,000,000 pesos de oro. At that date the external debt of Colombia amounted to 8,508,000 pesos de oro, besides a debt of 11,355,065 pesos de oro which had been incurred to promote the construction of railways. Upon these debts the Government was paying interest regularly through a London firm. The internal debt of Colombia was composed of the consolidated debt and the floating debt, amounting respectively to 2,848,260 pesos de oro and 10,840,654 pesos de oro. The total debt in July 1920 amounted to 35,040,073 pesos de oro, excluding some 4,000,000 pesos de oro of current obligations.

**Monetary System.**—By a law of 1909 the regulation of Colombia's currency was entrusted to a board which was directed to gather a gold reserve and to guarantee the redemption of the paper money and to give new bills and coins in exchange for old paper. The ratio of the gold peso to the pound sterling was fixed at 5 to 1. In 1915 an official estimate of the money in Colombia in U.S. currency was as follows:—

Paper money . . . . .	\$10,056,300
Silver coin . . . . .	4,004,700
Nickel coin . . . . .	997,700
Colombian gold coin . . . . .	85,000
English and U.S. gold coin . . . . .	6,330,300
Old silver coin, Colombian and foreign . . . . .	3,000,000
Gold coin on deposit . . . . .	2,586,400
<b>Total . . . . .</b>	<b>\$27,086,400</b>

Early in 1916 the Government issued an order that paper currency should be exchanged at the rate of 100 paper pesos (moneda papel) for one peso de oro in coin or new banknotes. The monetary unit of Colombia was in 1920 the gold peso.

**History.**—On Aug. 3 1909, Gen. Ramón González-Valencia was elected by Congress to serve as president for one year in place of Gen. Reyes, who had resigned. On July 15 1910, Carlos E. Restrepo, a journalist and publicist, was elected president. President Restrepo aimed to restore the credit of the country, to rehabilitate the finances, and to make a satisfactory adjustment of the Panama affair. At the end of his term he refused to become a candidate for reelection. In the presidential election of Feb. 1914, a Conservative, José Vicente Concha, was elected president for four years. The Liberal candidate had withdrawn from the contest before the election was held; and President Concha, who was inaugurated on Aug. 7 1914, gave the Liberals minority representation in his Cabinet. His Minister of Foreign Affairs was the *libérateur* and statesman, Marco Fidel Suárez; and his Minister of the Treasury was the liberal leader, Diego Mendoza. Before the end of Concha's administration, however, the last-named minister resigned from the Cabinet. Aside from fiscal and diplomatic problems which he inherited, President Concha had to face new problems resulting from the war. In Oct. 1917 the Minister of Foreign Relations, whom the Conservatives had nominated for the presidency, resigned from Concha's Cabinet. Marco Fidel Suárez was elected president of Colombia in Feb. 1918. He was inaugurated on Aug. 7 for the term 1918-22.

Colombia's relations with Panama and the United States had long remained delicate because of unsettled questions arising out of the setting up of Panama as a separate State in 1903. After Gen. Reyes' visit to Washington failed, an attempt was made in 1909 to adjust those questions by a treaty negotiated by Colombia's envoy, Enrique Cortés, and Secretary of State Elihu Root. In connexion with the projected treaties between Colombia and Panama and between Panama and the United States, this treaty stipulated that Colombia should acknowledge Panama's independence; that Colombia should renounce all claims and declare Panama free from all debts incurred by Colombia before Nov. 3 1903; and that Panama should pay Colombia annually \$250,000 (U.S. currency) for 10 years. As this agreement was unacceptable to Colombia, on April 6 1914 Thaddeus A. Thompson, minister of the United States in Bogotá, and José F. Urrutia, Minister of Foreign Relations for Colombia,

signed a treaty containing expressions of regret by the United States for the difference that had arisen between herself and Colombia because of Panama, granting Colombia special privileges in the use of the Panama Canal, and providing that the United States should pay Colombia \$25,000,000 to recompense her for the damages due to Panama's independence. This treaty was ratified by a law of the Colombian Congress on June 9 1914. The apologetic phrases, in particular, occasioned delay in the United States; with modifications, in April 1921 it was ratified by the U.S. Senate.

After the outbreak of the war, Minister Fidel Suárez addressed a circular to the editors of Colombia, on Nov. 27 1914, exhorting them to observe a strict neutrality. In response to a communication of Germany's minister at Bogotá, announcing the renewal of the unrestricted submarine campaign, Fidel Suárez expressed a desire for an end of the war and deplored its effects. When he mentioned the use by belligerents of measures which rendered it difficult to save neutral property and innocent lives he declared that his Government reserved the right to protest and to demand justice. On June 2 1917 he sent a circular to the governors of departments stating the intention of his Government to observe neutrality in the war between the United States and Germany. In making this announcement he took occasion to deprecate certain attempts that had been made to show that Colombia "sympathized incorrectly with one or another of the belligerents." As one of the countries invited to accede to the League of Nations, the Government, in accordance with the authorization of Congress dated Nov. 3 1919, accepted and joined the League. In filing her adhesion, however, Colombia served notice that her acceptance of Article X. of the Covenant did not imply her acknowledgment of Panama as an independent nation. Two delegates from Colombia attended the assembly of the League at Geneva which adjourned in Dec. 1920.

See *Annual Report of the Council of the Corporation of Foreign Bondholders* (London 1910—); *Censo General de la República de Colombia levantado el 5 de Marzo de 1912* (Bogotá 1912); *Diario Oficial* (Bogotá 1910—); P. J. Eder, *Colombia* (London 1913); *Dirección General de Estadística: Comercio exterior de la República de Colombia, año de 1916* (Bogotá 1919); *Informe del Ministro de Instrucción Pública al Congreso Nacional* (Bogotá 1911—); *Informe del Ministro de Hacienda al Congreso* (Bogotá 1914—); *Informe del Ministro de Guerra al Congreso* (Bogotá 1914—); *Informe del Ministro de Relaciones Exteriores al Congreso* (Bogotá 1910—); *Mensaje del Presidente de la República de Colombia al Congreso Nacional* (Bogotá 1911—); *Monthly Bulletin of the International Bureau of the American Republics* (Washington 1910—); Pan-American Union, *Colombia, General Descriptive Data* (Washington 1910—); *Proceedings of the First Pan-American Financial Conference* (Washington 1915); *República de Colombia; Leyes expedidas por el Congreso Nacional en su Legislatura* (Bogotá 1911—); A. J. Uribe, *Anales Diplomáticos y Consulares de Colombia* (5 vols., Bogotá 1900-18). (W. S. Ro.)

**COLORADO** (see 6.717).—The pop. of the state in 1920 was 930,620; in 1910, 799,024—an increase of 140,605, or 17.6% as compared with 48% in the preceding decade. Native-born were 83.8% in 1910, whites 98%, negroes and Indians numbered 12,935, and there were 3,736 Chinese and 2,300 Japanese. The density of pop. increased from 7.7 persons to the sq. m. in 1910 to 9.1 in 1920. The decay of mining towns altered the balance between urban and rural pop.; in 1920 the urban pop. was 48.2%, the rural 51.8%; in 1910 the urban 50.7% and the rural 49.3%. The pop. in 1920 of the six cities then having a pop. of over 10,000, their pop. for 1910 and the percentage of increase, were:—

	1920	1910	Increase Per cent
Denver . . . . .	256,491	213,381	20.2
Pueblo . . . . .	43,050	41,747	3.1
Colorado Springs . . . . .	30,105	29,078	3.5
Boulder . . . . .	11,006	9,539	15.4
Greeley . . . . .	10,958	8,179	34.0
Trinidad . . . . .	10,906	10,204	6.9

Leadville decreased in pop. from 12,455 in 1900 to 7,508 in 1910 and to 4,059 in 1920.

**Agriculture.**—During the decade 1910-20 agriculture displaced mining as Colorado's most important industry. The number of farms increased 29.8%; to 59,934; their area 80.8% to 24,462,014 ac.; and their average size 39.2% to 408.1 acres. The value of all farm property increased 119.1% to \$1,076,794,749. Land values

were estimated at \$763,722,716; buildings at \$102,390,944; implements and machinery at \$49,804,509; and live stock at \$160,976,580. The farm crops in 1919 were:—

Crop	Acreage	Production	Value
All crops			\$181,065,239
Cereals, total	2,640,664	38,436,550 bus.	63,380,214
Corn	752,637	10,105,627 "	14,147,875
Oats	174,189	4,535,527 "	4,308,752
Wheat	1,328,616	18,260,663 "	37,616,960
Hay and forage	2,215,730	3,580,123 tons	60,769,080
Vegetables			24,804,225
Misc. crops, total	176,494		17,673,726
Fruits and nuts			8,751,678
Orchard fruits		4,627,825 bus.	8,226,734

The irrigated area was 2,792,032 ac. in 1909, 3,348,385 ac. in 1919, while acreage under all irrigation enterprises, whether completed or not, had decreased from 5,917,457 to 5,220,588 acres. Organized drainage enterprises, most of them having been rendered necessary by faulty irrigation, had affected 171,656 ac. at a cost of \$1,081,875. In 1920 there were in the state 420,704 horses, 31,125 mules, 3,099 asses and burros, 1,434,423 beef cattle, 322,193 dairy cattle, 1,813,255 sheep, 28,688 goats, and 449,866 swine. In the same year the number of poultry was 2,994,347, and there were 63,253 hives of bees.

**Mining.**—Colorado's rank among the states in the production of the principal metals in 1918 was as follows:—Radium, first, with an output of \$7,500,000; tungsten, first, with an output of \$1,833,600; gold, second, with an output of \$12,944,600; lead, second, with an output of 61,282,841 lb.; zinc, fifth, with an output of 88,141,748 lb.; silver, fifth, with an output of 7,071,768 oz.; copper, tenth, with an output of 6,423,919 pounds. Production of coal reached a total of 12,511,481 short tons in 1917. Petroleum production in 1917 fell off to 204,000 barrels. There has been great interest in the deposits of oil shale in the Green river formation in the western parts of the state. Processes for exploitation on a commercial scale have not yet been put in operation.

**Manufactures.**—From 1900 to 1920 the number of manufacturing establishments in Colorado nearly doubled, the number of persons engaged more than doubled, and the capital invested increased 225%. In 1919 there were 2,631 manufacturing establishments, employing 44,731 persons, using capital to the amount of \$243,827,000, and the value of the products was \$275,622,000. Higher prices rather than increased production caused most of the increase. In 1914 the state ranked thirty-second in value of manufactured products, which represented only 0.6% of the value for the United States. Beet-sugar manufacture became the leading factory industry in 1914. There were 14 operating plants in 1919, which manufactured sugar valued at more than \$37,000,000. Slaughtering and meatpacking products amounted to more than \$41,000,000. Flour and gristmill products ranked third in 1914, with a value of \$7,535,633; a moderate increase in output in 1919 was accompanied by high prices, giving that year an unusual value of \$20,000,000. Butter, cheese, and condensed-milk industries became important, their products being estimated at \$12,000,000 in 1919.

**Education.**—In 1919 the illiterates, 10 years of age or over, were 3.7% of the pop. of the state, although the foreign-born whites of those ages were 11.3%. There were 1,880 school districts in the state in 1919, maintaining 3,125 schools and employing about 7,500 teachers. The school pop. for the year ending June 30 1918 was 257,884, and the enrolment in public schools 191,199. Public school expenditures for the year were \$9,892,699. The total amount invested in school property was \$15,212,000, an average of \$79.68 per pupil enrolled. The state permanent school fund, derived from Federal land grants, amounted to \$4,048,492 in 1918. The income of the permanent school fund (about \$600,000) is apportioned among the school districts, giving about \$2.35 per capita of the school population. Sales and leases of school lands, and royalties on minerals, have increased the state school funds, and the unsold lands, together with coal and other mineral reserves, are estimated at \$125,000,000. County and district tax levies, the main source of school revenues, produced \$11,572,155 in 1918. There was a pronounced movement for the consolidation of rural schools, and for joint support of centralized schools in which two or more counties are interested. The Legislature of 1921 passed a law providing a minimum salary for teachers graded for the several classes of districts. Several districts in cities (notably in Denver, Colorado Springs, and Sterling) in 1920 adopted salary schedules which fixed higher standards for teachers with advanced professional training. Public high schools and institutions of higher education developed from 1910 to 1920 even more rapidly than elementary schools. Enrolment of students taxed the capacity of secondary schools and colleges, requiring increased taxation for current expenditures and bond issues for buildings. The enrolment in the secondary schools in 1920 was 24,404; in 1910, 11,495.

**Finances.**—The total bonded indebtedness of the state Nov. 20 1920 was \$4,187,300. The general assessment valuation of taxable property in 1919 was \$1,498,661,128, in 1920 \$1,591,307,396, of which there was a state levy of 3.47 mills, producing \$5,200,355 in 1919 and \$5,521,836 in 1920.

**History.**—A special session of the Legislature in 1910 submitted to the voters a constitutional amendment adopting initiative and referendum, which was ratified in Nov. of that year. The same special session adopted a primary election law, providing for direct nominations by the people of candidates for the U.S. Senate, Representatives in Congress, and all elective state, district, county, ward and precinct officers, as well as members of the state Legislature. This Act provided for party assemblies, at which party candidates might be designated to seek nominations in the primaries, every candidate receiving 10% or more of the votes of the delegates to the assembly being certified by the assembly as a candidate to enter the primaries. It was also provided that persons not entering the assembly might become candidates for any of the offices above mentioned by petition, the number of signers required being 300 for any official who is to serve any political district in the state greater than a county and 100 for other officials. The expense of candidates in such primaries was limited by the Act and severe penalties were provided for violations. In 1911 an Act was passed providing for registration of voters for all elections to be held in the state except school elections, and providing severe penalties for false registration and other violations of the Act. In Nov. 1912 the people approved amendments to the state constitution providing for recall of elective officials, and in certain cases, for the recall of judicial decisions. An Act proposed by initiative was passed at the same time, providing for a ballot without party headings.

The voters adopted in Nov. 1914 an amendment to the state constitution prohibiting the sale and manufacture of intoxicating liquor, which became effective Jan. 1 1916. The Legislature at its regular session in 1917 petitioned Congress to adopt an amendment to the Federal Constitution to prohibit the manufacture and sale of intoxicating liquors in the United States, and the prohibition amendment to the Federal Constitution was ratified by the Colorado Legislature in regular session Jan. 15 1919.

The Legislature in 1919 passed an Act providing for a budget system in making appropriations and creating a state budget and efficiency commissioner. The first budget prepared under this Act was presented to the Legislature in 1921. The Legislature in 1921 passed amendments to the constitution, for submission to the voters, proposing the extension of the tenure of state and county officers from two to four years. A proposal was submitted to the voters for a convention to revise the state constitution, this action being simultaneous with the failure of a series of Acts urged by the governor for the reform and consolidation of executive offices and boards. Persistent advocacy by the governor secured the passage of laws for reestablishment and encouragement of a national guard, for a department of safety with a force of rangers as a state police force, and for a substantial appropriation to be available to suppress riots.

There were a number of serious labour disturbances between 1910 and 1920, some of them marked by violence and virtual insurrection which had to be put down by the military forces. A notable contribution to better relations between capital and labour was the industrial representation plan put into effect by John D. Rockefeller, Jr., in the properties of the Colorado Fuel and Iron Co. in 1916. Employees, by districts and classified groups, elect representatives who have the right to confer with executives on all questions affecting wages, conditions of employment and operation, and general welfare. The success of the system in Colorado has had marked influence on similar large industrial organizations elsewhere.

In 1910 the state administration was in the hands of the Democratic party, with Joseph H. Shafroth as governor. The Democrats again elected a governor in 1912, Elias M. Ammons, a result largely due to the split in the Republican party throughout the nation. In 1914 George A. Carlson, Republican, was chosen governor. He was succeeded by Julius C. Ganter, Democrat, elected in 1916 when the leadership of President Wilson on international issues made his party dominant in the states, largely through women's votes. A reunited Republican party, profiting by popular reaction on war issues, elected Oliver H. Shoup as

governor in 1918, and reflected him in 1920 with an increased majority and a Legislature almost completely Republican.

During the World War, approximately 45,000 men from Colorado served in the army, navy and marine corps, of whom about 22,000 had been drafted. There were in the state 698,169 subscriptions to the Liberty and Victory loans, amounting to \$144,813,550, which was 24% more than the quota.

**Bibliography.**—Wilbur Fiske Stow, *History of Colorado* (three vols., 1918); Jerome C. Smiley, *Semicentennial History of Colorado* (1913); Irving Howbert, *Indians of the Pike's Peak Region* (1914); Prof. James F. Willard, *Union Colony of Greeley* (State Univ. Hist. Collections, 1918); Enos A. Mills, *Spell of the Rockies* (1911), *Rocky Mountain Wonderland* (1915), *In Beaver World* (1913), *Your National Parks* (1917); E. Parsons, *Guide Book to Colorado* (1911); A. C. Carson, *Colorado, the Top of the World* (1912); Mae Lacy Baggs, *Colorado, the Queen Jewel of the Rockies* (1918); Alice Falk Hill, *Colorado Pioneers in Picture and Story* (1915). (C. A. D.)

**COLOURS OF ANIMALS** (see 6.731).—Since 1910 the knowledge of animal coloration has been added to in many directions. Broadly speaking, however, the new facts confirm the views previously held, which are only modified in points of detail.

**Cryptic Colouring.**—As regards cryptic coloration, A. H. Thayer and his followers have shown that many arrangements of colour and pattern which had been previously considered to be revealing, are in truth concealing. A few biologists go so far as to express the view that all coloration is concealing and explain all cases of the mimicry of one animal by another, as due to a common cryptic (syncryptic) coloration, both animals having independently developed the same concealing coloration. Apart from mimicry, there are great difficulties in maintaining this thesis. The habits of many brilliantly coloured animals clearly prove that they do not seek to hide themselves but rather to show off their bright colours.

Mention may be made of the method of concealment by disruptive coloration first described by Thayer. This is for the concealment of animals likely to be seen against two or more backgrounds. An animal, for instance, coloured green and brown in large areas, when viewed against a green background will be visible in respect of its brown areas, and as these brown areas will not have the shape of the animal but will be like one of the many oddments of nature (stones, leaves, etc.) so the animal will be mistaken for one of these. It will be similarly concealed against a brown background in this case, only the green areas will be noticed. In these cases concealment is effected by disrupting the characteristic outline of the animal. The white areas which many animals present, are considered to be for disruption against the background of the sky, as, for instance, when a partially white bird in a tree is viewed against the low horizon. Many experimental findings and field observations form the basis of these conclusions.

Another use of pattern is to give a blurred or indistinct appearance to an outline. It is common to find, along the margin of the wings of butterflies and moths, a very small black and white, or contrasted, pattern which is visible at short distance; at longer range the pattern blends and then the margin has an indistinct appearance, causing the insect to fade into its background. The finely spotted, barred and striped patterns of many mammals and birds are similarly effective in concealing the outlines at distance the spots cannot be seen.

The solidity of an animal is concealed by what is now called counter-shading, namely, by the darkening of surfaces exposed to the light, and the whitening of those in shadow. Large dark spots or broad dark stripes on the back, gradually changing to small spots and narrow stripes on the under sides, has the same concealing effect and the added advantage of a blurred outline when the animal is viewed at a distance. The very remarkable striped pattern of the zebra has been considered to be of this nature. In some animals not only is their solidity thus concealed, but a false solidity or modelling is superimposed. A flat surface is often made to appear rough or uneven this is effected by an arrangement of light or dark tones used in a manner precisely similar to that by means of which the artist produces the illusion of a solid object on a flat canvas.

The use of colour in animal coloration can at present only be very imperfectly understood because little is known of the colour vision of animals. There is some evidence that animals have a colour perception less sensitive than man; if such prove to be the case, then a ready explanation for several dimorphisms is available. For instance, among insects it is common to find that whilst some individuals of a species are green, others are brown; but towards a colour perception slightly less sensitive than man's, these colours will be indistinguishable, and thus against either green or brown backgrounds neither the brown nor green individual would have the advantage. A common defect in man's colour sense is an inability to distinguish red from green, it is possible that such a colour as the red of the robin's breast against green foliage may serve to conceal the bird from its enemies.

When bright colours are used for revelation, as shown by the animal's habits, and by the particular pattern and position which the colour occupies, then advantage appears to be taken of the fact that red is a very conspicuous colour at high illuminations and blue at low illuminations. The brilliant inhabitants of the forest present a preponderance of blue, whereas red is more often found among those living in the open. This also applies to flowers, the bluebell typifying the colour for woods and the poppy for the open.

Experiments have shown that it is possible to determine, in many cases, whether a given pattern is for concealment or revelation for instance, it has already been mentioned that concealment may be effected by a pattern which breaks out along the animal's margin and thus tends to conceal its characteristic shape. Conversely, patterns which follow an animal's margin and tend to accentuate its characteristic shape and separate it from its surroundings, make for revelation. A pattern of this kind, commonly seen in butterflies, is a broad black band following the outer margins of both wings and often enclosing a brilliant yellow or blue central area. Experimental evidence of this kind, as well as that derived from a study of an animal's habits, is strongly against the view that all coloration is for concealment.

The concealment of cast shadow is commonly brought about by the crouching or squatting of either hunted or hunter. Among butterflies Marshall has pointed out two methods of avoiding cast shadow. Certain species when resting on the ground with closed wings will tilt over the wings, generally away from, sometimes towards the sun, thus reducing and hiding the shadow cast upon the ground. Other species will settle on the ground with wings spread and orient themselves so that either their head or more often their tail is pointed at the sun. Should a bird or other enemy come near they at once close the wings over the back and then only a line shadow of the wings is cast on the ground.

**Sematic Colouring.**—Passing on to the consideration of sematic or signaling coloration, certain advances have been made. Feeding experiments have shown that the preyed-upon can be arranged in a series, for any given preyer, from the most to the least palatable. The former will be eaten when the preyer's hunger is almost satisfied; the latter, only when the preyer is starved. The colours of this series are then found to be arranged from cryptic coloration corresponding to the very palatable, to a revealing (warning) coloration for the very unpalatable. Further, it has been observed that in many cases, whilst concealment by a cryptic coloration is the usual form of protection, nevertheless, a revealing coloration is exhibited to the preyer, when concealment has failed. This revealing coloration, such as the hind wing of a moth, is as a rule hidden by a cryptically coloured fore wing, and is only revealed at the last moment to advertise a relative unpalatability. There is also evidence obtained from watching feeding birds, that revealing coloration is used for deception in the manner of a conjuring trick. Thus, the Leaf butterfly (*Kallina*) when flying appears blue and yellow, but directly it settles with closed wings it becomes like a dead leaf. The pursuing bird will continue to look for the blue and yellow insect among the dead leaves in which the insect has taken

refuge. Many grasshoppers and moths look red and blue when flying, but on settling, these bright colours are at once hidden.

Swynnerton has suggested the substitution of "distinctive coloration" for "warning coloration", the assumption is that the prey will remember the distinctive colours and patterns, and associate them with their varying palatability. In support of this there is much evidence to show that many animals have a good memory in this respect.

**Mimicry.**—In view of the fact that insects can be graded in respect of their palatability, the distinction between Mullerian and Batesian mimicry appears difficult to maintain. A set of animals presenting common warning coloration (Mullerian mimicry) are never equally unpalatable, and therefore it may be said that the relatively palatable of this set are of the nature of Batesian mimics. Although in extreme cases a distinction may be drawn, nevertheless intermediate cases occur which it is impossible to classify in this way. In the study of mimicry many notable advances have been made, chiefly among butterflies. Several insects which were thought to be different species, or varieties, have lately been shown by breeding-experiments to be polymorphic forms, the same species mimicking sometimes one species and sometimes another, both forms being bred from the same mother. Also it has been shown that, in situations where models are scarce, the mimicking species presents transitions between its various polymorphic forms, and this fact is considered to indicate that natural selection is required to maintain a mimicry. At one time it was thought that butterflies had few enemies, and that therefore their remarkable mimicry could bear no relation to natural selection, however, evidence that they are eaten by birds to a considerable extent has been brought forward by several observers.

**Sexual Coloration.**—Secondary sexual coloration still gives rise to much speculation. The Darwinian view that it represents selection by the female is still held by some observers. Others consider that it serves the purpose of stimulating the sexual instinct of the female; or that it is related to the different habits of the male and female, as, for instance, the incubation of eggs, or that it represents a difference in value to the species between male and female, making the conspicuous but less valuable male more likely to be destroyed by enemies than the inconspicuous and valuable female. These various theories are mentioned to show that no general law to explain these colorations has been accepted. Much valuable field work has been done in which many new facts as regards sexual displays have been collected.

**Chemistry of Animal Colours.**—It has been shown that, in the case of the lobster and salmon, the colours which the males assume at the breeding-season are due to the laying down of a coloured waste product in the scales and shell. This waste product is finally got rid of when the scales become worn and the shell cast. In the case of the female the waste product is discharged in quite a different manner; it is deposited in the eggs and disposed of when they are laid. In certain parts of England and Germany, chiefly in the neighbourhood of large towns, many species of moths have developed melanotic forms, or these dark forms have greatly increased in number. Much work has been done in an endeavour to discover the cause of this change, as it was at one time thought to be a case of the acquirement of a dark coloration for concealment against sooty surroundings, and thus to be an example of the rapid action of natural selection. Melanism, however, occurs in other districts, distant from large towns, more particularly near the sea. Recently evidence has been brought forward that this change is due to the particular feeding of the caterpillar; that, in fact, a deposit occurs on the leaves near large towns and near the sea, which causes this change.

**Physics of Animal Coloration.**—Several eminent physicists have taken an interest in, and attempted to explain on a physical basis, the brilliant metallic and iridescent colours of many insects and birds. Although a physical explanation of the coloration of most objects is available the brilliant colours of these animals remain a mystery. A recent summary by the late Lord Rayleigh in the *Philosophical Transactions* may be quoted:—"These colours are probably structural rather than pigment, but still

much remains to be effected towards a complete demonstration of the origin of these effects. Even if we admit an interference character questions arise as to the particular manner and there are perhaps possibilities not hitherto contemplated."

It has been suggested that fluorescence plays a part, and to test this insects have recently been examined in a beam of ultra-violet light. It was found that the brilliantly coloured species are not fluorescent. A few Lepidoptera were found to be fluorescent and this character has been found to be of some service in classification, as the property appears to be limited to closely allied species when it occurs in a group.

**AUTHORITIES.**—Carpenter, *Naturalist on L. Victoria*; Dixey, *Practical Address Ent. Soc.* (1911); Howard, *British Warblers*; Longstaff, *Butterfly Hunting in Many Lands* (1912); Marshall, *Trans. Ent. Soc.* (1909); Mottram, *Proc. Zool. Soc.* (1915, 1916, 1917) and *Controlled Natural Selection* (1914); Poulton, *Essays on Evolution* (1908); Punnett, *Mimicry of Butterflies*; Pyrcraft, *The Colouring of Animals* (1913); Swynnerton, *Journ. Linn. Soc.* (1919); Thayer, *Concealing Coloration in the Animal Kingdom* (1909). See also the article CAMOUFLAGE. (J. C. Mo.)

**COLOUR-VISION AND COLOUR-BLINDNESS** (see 28.139).—Much new work has been done in research on these questions, which have become increasingly important in practical life; and a restatement is needed (1921) of the accepted views.

**The Physical Basis of Normal Colour-Vision.**—White light can by means of a prism be split up into its constituent parts to form a spectrum which shows a number of colours. The spectrum or rainbow consists of a series of waves of light of different refrangibility extending from the red, which are the largest waves to violet, which are the smallest. These waves are similar to those of the sea, only infinitely smaller. Similar waves, differing in size and not giving rise to a sensation of light, are found above the violet and below the red. In the visible spectrum we have a physical series arranged in consecutive order, each member of the series differing in wave-length.

**Special Physiological Facts in the Appearance of the Spectrum.**—If a number of persons be asked to state how many definite colours they see in the spectrum, very different answers will be obtained. The large majority will say that they see six colours, red, orange, yellow, green, blue and violet. A few will state that there are seven colours, indigo being added as a colour, being seen in the region of blue-violet. Newton appears to have seen the spectrum in this way. The spectrum may be examined in another way, certain portions of it being isolated between two shutters. An extraordinary fact then becomes apparent, viz. that large divisions of the spectrum appear monochromatic, as if they had been painted with one brush of colour, though physically every part of the division differs. Most normal-sighted persons divide the spectrum into about 18 monochromatic divisions, those with super-normal colour-perception, into about 25, and those with diminished colour-perception a less number. For instance, those who see three colours in the spectrum generally divide it into ten monochromatic divisions. These divisions when examined by a normal-sighted person appear quite wrong and to contain several colours instead of one. It is obvious that a man who sees only ten colours instead of 18 will confuse colours which appear different to the normal-sighted.

**The Anatomical Basis of Vision and Colour-Vision.**—It is upon the outer layer of the retina, the membrane lining the back of the eye, that the images of external objects are formed. The outer layer of the retina is the layer farthest away from the front of the eye, so that light has to pass through all the other layers before it reaches the sensitive portion. This sensitive layer consists of two elements, which are called respectively, on account of their shape, the rods and cones. A little dip in the centre of the retina, the fovea, is the region of most distinct vision. In the fovea only cones are present. External to the fovea the rods are arranged in rings round the cones, and the proportion of rods to cones increases as portions of the retina farther from the fovea are taken, except at the extreme periphery, where, again, only cones are found. In the outer segment of each rod there is a rose-coloured substance, the visual purple, which is photochemically sensitive to light. This visual purple is not found in the cones, but only in the rods. It was for this reason that it was not considered to be essential to vision, because it was absent from the cones, and only cones are to be found in the fovea, the region of most distinct vision. Though the visual purple is not present in the cones of the fovea, it is found between them, four special canals aiding the flow from the periphery to the centre of the fovea. When there is no visual purple in the fovea it is blind. The rods and cones project into a thin layer of fluid, which is kept in its place by a membrane.

The visual purple is diffused into this fluid and on being decomposed by light stimulates the cones, thereby setting up a nerve

impulse, which causes the sensation of vision. The movements of after-images show that the stimulus in vision is fluid and attenuated outside the cones. The rods are not percipient elements but regulate the formation and distribution of the visual purple.

The decomposition of the visual purple by light stimulates the ends of the cones, and a visual impulse is set up which is conveyed through the optic nerve fibres to the brain. The character of the impulse differs according to the wave-length of the light causing it. Therefore in the impulse itself we have the physiological basis of the sensation of light, and in the quality of the impulse the physiological basis of the sensation of colour. The impulse being conveyed along the optic nerve to the brain stimulates the visual centre, causing a sensation of light, and then, passing on to the colour-perceiving centre, causes a sensation of colour. But though impulses vary in character according to the wave-length of the light causing them, the colour-perceiving centre is not able to discriminate between adjacent impulses, the nerve cells not being sufficiently developed.

Even with the normal-sighted there is room for much further development in the discrimination of colour, but when the development is not up to the normal standard or there is a defect in any portion of the apparatus diminishing the power of discrimination, colour-blindness is the result.

*Evolution of the Colour-Sense.*—There can be no doubt that an evolution of the colour sense has taken place. The only point is, how, and when, did this occur? It is obvious that in those low forms of animal life in which the most rudimentary sense of sight exists there can be no sense of colour. The animal which can only perceive light and shade, can only discriminate in a rough way between varying intensities of the stimulus. It is obvious, therefore, that the sense of light must have been developed first and then the sense of colour. The sense of sight must have been first developed for those waves which produced their maximum effect upon the sensitive protoplasm.

The next process of development would be for the protoplasm to become sensitive to the waves above and below those which first caused an effect. In the physical stimulus which produces the sensation of light there are two factors to be considered, the length of the wave and its amplitude; the greater the amplitude within certain limits the greater the intensity of the sensation.

The wave-length of the physical stimulus is the physical basis of the sensation of colour. How did the sensation of colour first arrive? Let us suppose that the physiological effect of the physical stimulus differed according to the wave-length of the physical stimulus. At a certain stage the eye had become sensitive to a fair range of the spectral rays, that is to say, evolution had proceeded to the extent of making the protoplasm sensitive to rays of light considerably above and below those which first caused a sensation of light. There was then an eye which was sensitive to the greater part of the rays which form the visible spectrum. It was, however, an eye which was devoid of the sense of colour, no matter from what part of the spectrum the rays were taken. The only difference appreciated was one of intensity. Let us now suppose that a fresh power of discrimination was added to the eye and that it became able to discriminate between different wave-lengths of light. What would be the most probable commencement of development of the sense of colour? Most probably the differentiation of the physical stimuli which were physically most different. That is to say, the eye would first discriminate between the rays which are physically most different in the visible spectrum, the red and the violet; that is, presuming that the eye had become sensitive to this range. We have examples of cases of defective light-perception in which there is shortening of the red or violet end of the spectrum.

Let us now work out the evolution of the colour sense on the assumption that the rays which are physically most different, namely red and violet, were those which were first differentiated. We know that the various rays differ in their effects on substances, the red rays are more powerful in their heating effects, whilst the violet are more active actinally, as is well known by the readiness with which they act upon a photographic plate.

We should now have an individual who would see the spectrum nearly all a uniform grey of different degrees of luminosity but with a tinge of red at one end and a tinge of violet at the other. There is a great deal of evidence to show that this is how the colour-sense was first developed. For instance, in the degree of colour-blindness just preceding total the spectrum is seen in this way.

It will be noticed in the first evolution of colour that the added power of discrimination is something distinct and separate from light-perception. It can be destroyed as by mixing the two colours without interfering with the perception of light. Here we have the foundation for the distinction between light and colour-perception, the proper recognition of which is so essential in physiological optics. As the colour-sense developed it was not necessary that the rays should be so far apart before a difference was seen, so the two colours red and violet gradually encroached on the grey band until they met in the centre of the spectrum.

We have now a series of cases each of which only sees two colours, red and violet, with a varying degree of grey band in the centre of the spectrum. We should expect that those who had the smallest white region left in the centre of the spectrum would have the best colour-perception, because they belong to a later stage of evolution.

Cases of colour-blindness are found corresponding to all these degrees, from almost total to those bordering on the trichromic.

In all the dichromics a mixture of the two colours which they perceive, namely red and violet, will form white, and so we have the foundation of complementary colours.

The next stage in the evolution of the colour-sense was when a third colour appeared at the third point of physiological difference, that is in the centre of the spectrum in the position of the green.

The colour-sense now assumed a trichromic form, red, green, and violet being seen in the spectrum.

As green replaced the grey which existed in the spectrum of the dichromic we should expect that green should be complementary to the other two colours combined, and this we find to be the case.

We have now reached the stage in which three distinct colours were seen in the spectrum, namely red, green, and violet, and the vision has assumed the trichromic character which must remain.

When the green was first developed it was a comparatively unimportant colour. As evolution proceeded the power of differentiation affected the regions between the red and the green, and the violet until a stage was reached in which a fourth colour, yellow, was seen at the next point of greatest physiological difference.

The next step in the process of evolution occurred when the retino-cerebral apparatus was able to differentiate a fresh colour between the green and the violet, namely blue, five definite colours being seen in the spectrum. It will be obvious that in any further evolution the intermediate portions will be still further differentiated, and so we arrive at those who can see six and seven colours in the spectrum respectively.

It is not necessary to consider the further evolution of the colour-sense because it is not known that any person can distinguish more than seven definite colours in the spectrum.

*Colour-Blindness.*—Colour-blindness is not really a good term for the defect so named. Though in certain varieties there is actual blindness to colour, in the ordinary varieties colours are clearly seen and seen as colours, but there is a lack of power to differentiate between them: for instance, reds are confused with greens and greens with reds. A colour-blind man picked up a red-hot coal, remarking as he did so, "What funny green thing is this?" The case which first drew general attention to the subject of colour-blindness was that of Dalton, the famous chemist. After Dalton had received the scarlet gown of a doctor of civil law at Oxford, he actually wore it for several days in happy unconsciousness of the effect it produced in the street. When he was asked what the bright scarlet gown which he wore resembled, he pointed to some evergreens outside the window and said the colours were exactly similar to him. The lining of the gown, which was pink, he stated appeared to him sky-blue.

A soldier in the days when they wore scarlet coats took off his coat and put it on a hedge, and was quite unable to find it when he wished to put it on again, though it was the most conspicuous object in the landscape to other people. Many colour-blind golfers find great difficulty in recognizing the red flags on the greens at a distance.

Those who are colour-blind often first discover their defect as children by finding great difficulty in picking cherries or strawberries, because of the similarity in colour to their leaves. A colour-blind man has bought a bright green tie under the impression that he was purchasing a brown one, an artist has painted the face of a portrait green and trees red. A colour-blind man has written half of a letter in black ink and half in red ink, under the impression that the whole was written in black ink.

At first sight it would seem a very easy thing to detect persons who make such errors. Though this is true in certain cases it is not so in others. In fact, cases have been submitted to experts who have failed to detect them after an hour's examination.

A musician's wife informed the writer that she had tested her husband again and again and was quite sure that he was not colour-blind, and that he was able to see colours as well as she could, she was only convinced when she found that he was quite unable to read any of the letters on the card test.

Cases of colour-blindness may be divided into three classes, which are quite separate and distinct from each other though one or more may be present in the same person. In the first class there is light as well as colour loss. In the second class the perception of light is the same as in the normal-sighted, but there is a defect in the perception of colour. In the first class certain rays are either not perceived at all or very imperfectly. Both these classes are represented by analogous conditions in the



perception of sounds. The first class of the colour-blind is represented by those who are unable to hear very high or very low notes. The second class is represented by those who possess what is commonly called a defective musical ear. Colour-blind individuals belonging to this class can be arranged in a series. At one end of this series are the normal-sighted, and at the other end the totally colour-blind. In the third class of the colour blind there is defective perception of colour through the fovea or central region of the retina not being normal.

Abnormalities and defects of light-perception may be subdivided as follows:—

1. Increase or diminution in the visible range of the spectrum.
2. Defective sensibility for certain wave-lengths.
3. Increased sensitiveness for certain wave-lengths.
4. Variations in the maximum of the luminosity curve.
5. Increase or defects in the power of dark adaptation:—(a) Very rapid or slow adaptation; (b) very complete or imperfect dark adaptation.

If a number of persons be examined with a bright spectrum as to the point when they first see light where the red commences and the point where violet terminates, it will be found that there are considerable variations in different cases.

A very common mistake due to shortening of the red end of the spectrum is the confusion of pink and blue. If a person with considerable shortening of the red end of the spectrum is shown a pink which is made up of a mixture of red and violet, the red consisting of rays occupying the missing portion of the spectrum, only the violet is visible to him, and so the pink appears a violet without a trace of red. This pink is therefore matched with a violet or blue very much darker than itself.

An examination of those belonging to the second class of the colour-blind will show that those who are only slightly defective will declare that there are only five colours in the spectrum, orange not being seen as a definite colour, but as a yellowish-red. Another set will be found who will state that there are only four definite colours, red, yellow, green, and violet. Those who are still more defective will state that there are only three colours in the spectrum, red, green, and violet. These describe the spectrum as red, red-green, green, green-violet and violet. Then there are those who state that there are only two colours in the spectrum, red and violet, with a neutral point in the green. This neutral division between the red and the violet may in extreme cases be so large that only the ends of the spectrum appear coloured with a large grey region between. Finally there are persons who see no colours in the spectrum, but see it as a colourless band varying in luminosity in its different parts. It will be seen therefore that we can classify the degrees of colour-perception according to the number of definite colours which are seen in the spectrum. Those who see seven colours may be called heptachromic, those who see six, hexachromic, those who see five, pentachromic, those who see four, tetrachromic, those who see three, trichromic, those who see two, dichromic, and finally the totally colour-blind.

It might at first be thought that this classification was artificial and that some of the classes saw exactly alike, but further examination will show that this is not the case. Those who see six colours in the spectrum know that there are several varieties of green, but all these are associated by their green character, and are plainly compound and not simple colours; for instance, in yellow-green it is quite obvious that the colour is a mixture of yellow and green, and hence the term yellow-green correctly describes it. The trichromic designate yellow as red-green and this does not correctly describe yellow for the normal-sighted.

**The Tests for Colour-Blindness**—On account of the arrangement of signals by sea and land it is necessary that persons employed in the marine and railway services should be able to recognize and distinguish between the standard red, green, and white lights, in the requisite conditions.

It is not only necessary to find out whether a man is able to distinguish between the red, green, and white lights, but to ascertain as well that he thoroughly understands what is meant by colour, and the individual character of red, green and white respectively. Too little attention has been paid to this in constructing tests for colour-blindness, and those who have had much practical experience in testing for this defect, are aware of the ignorance which exists among uneducated persons with regard to colours. Many are under the impression that every shade of a colour is a fresh colour, and others have the most novel ideas with respect to colours. It is necessary that a sailor or engine-driver should be able to recognize a red, green, or white light by its character of redness, greenness, or whiteness respectively, that he has definite ideas of colour and is able to reason with respect to them. All persons who are not able, through physical

defect, to have definite ideas of the standard colours and to be able to distinguish between them, must be excluded from the marine and railway services. An engine-driver or sailor has to name a coloured light when he sees it, not to match it. He has to say to himself, "This is red light, therefore there is danger," and this is practically the same as if he made the observation out loud. Therefore, from the very commencement we have colour-names introduced and it is impossible to exclude them. Making a person name a colour is an advantage, because the colour-name excludes the element of shade. If, as some persons have said in the past, testing by colour-names is useless, then the whole series of colour-names is useless. But if I say to a friend, "That tile is red," and he agrees with me, it is evident that one object the colour of which is by him classed as red, is also classed as red by me. The ordinary colour-names, red, blue, yellow, and green, form excellent bases for classification. The engine-driver is told that red is a "Danger" signal, green an "All Right" signal. Therefore it is necessary that he should know what is meant by these colours. It is on account of there being so many variations in hue that such great difficulty has been found in constructing an adequate test for colour-blindness, as it is the definite colour and not the variation of them of which we wish to know the number. The colour-blind see a distinct difference in hue, luminosity and saturation. The normal-sighted could divide the green of the spectrum into yellow-green, green and blue-green, and would, in the majority of cases, be able to range all greens under these three classes. The dichromic colour-blind see two colours only, and name colours as variations of these two differing in luminosity and saturation, they recognize yellow by its superior luminosity and distinguish between red and green by the latter appearing of less saturation.

The test which should be used for the marine and railway services is a lantern in which the requisite conditions are represented. A lantern of this kind is used by the Admiralty and the Board of Trade. It is obvious that a man who cannot distinguish the red, green and white lights in these lanterns will not be able to do so in actual practice, and this fact is easily proved by testing with signal lights.

Another test for colour-blindness, a card test,<sup>1</sup> is useful but it is not intended for the decisive testing of sailors or railway men, though it may be used as a supplementary test. It is for use when the lantern is not available, and is probably the simplest for demonstrating to the normal-sighted person defective colour-vision in a subject. The principle involved is the perception of difference between two colours presented in a special diagram of spots of irregular shape and various tones. On a ground of separate spots of one colour a letter is formed in spots of another colour. The test consists in discriminating between the colours, and hence recognizing the letters.

This test is useful for children as it is of importance that any one who is colour-blind should know of it at the earliest time, so that he can avoid occupations in which an accurate colour-sense is necessary.

The wool test is a failure. It is now obsolete, as it allows over 50% of dangerously colour-blind persons to pass, and it will be noticed in certain reports that of those who were rejected by the wool test and who appealed, over 50% were found to be normal-sighted and had been rejected wrongly. The colour-blind people who can pass the wool test see a slight difference between the colours, but the smallness of this is shown by the card test.

**Theories of Colour-Vision.**—The facts of colour-vision are quite inconsistent with the older theories of colour-vision, and modifications of the theories made to explain particular cases at once give rise to difficulties in the explanation of other facts. All fundamental observations should be made with pure spectral light as the use of coloured wools, coloured papers and pigments gives rise to results which are different and due to the defects of the methods employed.

The trichromatic theory, which assumes that there are three fundamental sensations the mixture of which gives rise to all other colour-sensations, was based on the facts of colour-mixing. Undoubtedly normal colour-vision is trichromatic in the sense of colour-mixing; therefore the term trichromatic theory is not a good one and has led to much confusion. The three-sensation theory would

<sup>1</sup> Published by G. Bell & Sons, London, 1930.

be a better term. The three-sensation theory is only one explanation of the fact that when spectral green and spectral red are mixed they make yellow. The explanation that when red and green are mixed the resulting impulses cannot be distinguished by the nerve cells from those caused by simple yellow is sufficient. This explanation is supported by the fact that the trichromatic see yellow as red-green. There is no evidence that the assumptions of the three-sensation theory are true. Simple yellow cannot be split up into its hypothetical red and green constituents. An hour's dark adaptation does not alter the hue of spectral yellow. As blue is supposed to be made up chiefly of the green and violet sensations, and yellow to be made up chiefly of red and green sensations, the green element should be affected after fatigue with blue, and yellow viewed subsequently should appear red. This is not the case. The eye may also be fatigued with spectral yellow, so that all yellow disappears from the spectrum without affecting the appearance of a very feeble red. It is known that if the intensity of a number of coloured lights be reduced in the same proportion all the colours do not disappear at the same moment. If, therefore, spectral yellow were a compound sensation it should change colour on being reduced in intensity. If, however, spectral yellow be isolated in the spectrometer, and the intensity be gradually reduced by moving the source of light away, the yellow becomes whiter and whiter until it becomes colourless, but does not change in hue.

In cases where a subjective red is seen with an illumination by white light, this red is seen with a compound yellow but not with a simple spectral yellow.

When the theory is applied to colour-blindness it is still more unsatisfactory and is quite unable to explain the fundamental facts, as for instance why the colour-blind should make an increased monochromatic division in the spectrum or why certain colour-blind persons should be able to pass the wool test. Again no explanation is offered of the fact that simultaneous contrast is increased in the colour-blind. One of the best-known cases of colour-blindness, a simple dichromic, was classified by one expert as a case of complete red-blindness and by another as a case of complete green-blindness!

The present writer has never examined a single case of colour-blindness which, on a detailed examination with spectral colours, could be explained on the three-sensation theory. For instance, a case of shortening of the red end of the spectrum may be taken in which the red is shortened to  $\lambda 680$ ; at  $\lambda 670$  the perception of red may be defective to about half the normal and at  $\lambda 660$  it may be quite normal. This can be proved with a colour-mixing apparatus with the equation  $\lambda 670 + 535 = \lambda 589$ . If red  $\lambda 660$  be substituted for red  $\lambda 670$  an absolutely normal match will be made; if red of  $\lambda 670$  be used, twice as much red will be put in the mixed colour as with the normal, and if red of  $\lambda 680$  be used a match is quite impossible in any circumstances. Now on the three-sensation theory a case of this kind may be classed as  $\frac{5}{5}$  red-blind, all the ordinates of his red sensation curve being supposed to be reduced to one-half of the normal, but the red in the shortened portion should according to this hypothesis be brought up to the normal by doubling the amount of red, whereas it will be found when there is complete shortening that any amount of red light from the shortened portion may be added without being perceived. In another way it can be conclusively proved that the shortening is not produced by the diminution of a hypothetical red sensation which is stimulated by rays from every part of the spectrum. A man with shortening of the red end of the spectrum will match as identical pink and blue wools, the pink wool appearing much lighter to the normal-sighted than the blue one. If these two wools be now viewed through a blue-green glass which is opaque to the rays occupying the shortened portion, they will appear identical in hue and shade. It should be noted that whilst the blue-green glass cuts off the physical red rays it transmits numerous rays supposed to stimulate the red sensation.

When three selected spectral colours, for instance red, green and violet, are mixed in suitable proportions a white is made which will exactly match the white from which the spectrum was formed. On the three-sensation theory the two are physiologically identical, that is to say, the three hypothetical sensations are stimulated in similar proportion by the mixture and by the white light, though the two are physically different. It is essential to the three-sensation theory that after fatigue (say) to red or green the match should still remain, and supporters of the theory state that no change is observed in these circumstances. This, however, is not the case, and if a number of normal-sighted persons view the white equation after fatigue with red light, which is supposed to affect only the hypothetical red sensation, the match is no longer correct, and a very remarkable fact becomes apparent, namely, that much more red will be required in the mixed white.

The mixed white appears a bright green to a person whose eyes have been fatigued for red, and in order to make a match the amount of green has to be reduced to about one-half, so that the mixture now appears bright red to a normal-sighted person with unfatigued eyes.

See F. W. Edridge-Green, *The Physiology of Vision* (G. Bell & Sons, London, 1920). (F. W. E.-G.)

**COLUMBIA UNIVERSITY** (see 6.730).—The work of Columbia University during the period 1910-20 was greatly extended. A school of journalism was founded in 1912, a school of business in 1915, and a school of dentistry in 1917. In order to render the largest possible service to the community, courses in university extension were organized for men and women who could give only a portion of their time to study, but who desired to pursue subjects included in a liberal education. These courses, as such, did not lead to degrees, but might be offered as credit toward a degree under one of the faculties. Under university extension there was organized also an institute of arts and sciences which conducted series of lectures and recitals of a popular nature, as well as a system of courses for home study for persons unable to attend classes in the university. These courses also did not lead to academic credit or degrees. In 1920 there were in Columbia University in all departments 1,150 instructors and administrative officers, and in the twelve months ending June 30 1920, 28,314 students were enrolled. Of these, roughly one-third were registered in the 1919 summer session; one-third in the degree-granting schools and faculties during the academic year 1919-20; and one-third in university extension during the academic year 1919-20.

The productive endowment of the university, including the endowments of Teachers College, Barnard College, and the College of Pharmacy, amounted in 1920 to \$47,000,000, which, added to the property occupied for educational purposes, made a total capital investment of \$72,000,000. To meet the increased costs of education, the fees in the several schools were raised so that they ranged in 1921 from \$250 to \$350. The alumni of the university were given a definite part in the government of the institution by an agreement under which six of the 24 trustees were elected on alumni nomination. In 1912 the corporate title of the university was changed from the "Trustees of Columbia College in the City of New York" to the "Trustees of Columbia University in the City of New York."

The university took an active part in the World War. Immediately upon the severance of diplomatic relations with Germany in Feb. 1917, it placed its resources, both physical and intellectual, at the service of the Government. There were established at the university schools for training men for both the army and the navy, including work in radio, photography, quartermaster routine, explosives, gas engines, submarine detection, and the Student Army training corps, which prepared men for the various officers' training camps of both armed services. Students, faculty, and alumni to the number of 4,125 were enlisted in the army and navy, and 2,175 left their previous occupations and assisted the Government in some one of the civilian branches. Two hundred Columbia men died in the war. (N. M. B.)

**COLVIN, SIR SIDNEY** (1845— ), English man of letters (see 6.748), was knighted in 1911, and retired from his position in the British Museum in 1912. In 1911 he published an edition of the *Letters of R. L. Stevenson* and in 1917 *John Keats, His Life and Poetry*. His autobiographical *Memoirs and Places* appeared in Nov. 1921.

**COMBES, [JUSTIN LOUIS] ÉMILE** (1835-1921), French statesman (see 6.751). The campaign for the separation of Church and State was the last big political action in his life. While still possessed of great influence over extreme Radicals, M. Combes took but little public part in politics after his resignation of the premiership in 1905. He joined the Briand Ministry of Oct. 1915 as one of the five Elder Statesmen, but without portfolio. He died May 26 1921.

**COMMERCE, DEPARTMENT OF**, one of the executive departments of the U. S. Government. It succeeded the earlier Department of Commerce and Labor, by an Act of Congress, approved March 4 1913, which also created a separate and independent Department of Labor (see LABOR, DEPARTMENT OF). The Secretary of Commerce is a member of the president's Cabinet but is not in line of succession to the presidency. It is his duty to promote the commerce, domestic and foreign, of the United States. There is also an assistant secretary and a solicitor, the latter acting as legal adviser to the Secretary and to the heads of the various bureaus of the department.

As originally organized there were 9 bureaus, as follows: (1) The bureau of the census, charged with the collection of data concerning population, agriculture, manufactures, mining, etc.; (2) the bureau of foreign and domestic commerce, for the collection and diffusion of information of use to the manufacturer and exporter; (3) the coast

and geodetic survey, for charting coast waters and surveying rivers to the head of tidewater or ship navigation and for making deep-sea soundings, magnetic observations, etc.; (4) the bureau of fisheries, for regulating and conserving fisheries; (5) the lighthouse service, in charge of the aids to navigation on all U.S. territory, except Panama and the Philippines; (6) the bureau of navigation, having general superintendence of the commercial marine and merchant seamen, and the enforcement of navigation laws; (7) the steamship inspection service, which inspects steam vessels for the purpose of insuring safety at sea, and issues licences to masters, mates, pilots, and engineers of the merchant marine; (8) the bureau of standards, for determining all American measurements; and (9) the bureau of corporations. The last-mentioned bureau, on March 16 1915, was transferred to, and merged with, the Federal Trade Commission (see FEDERAL TRADE COMMISSION).

Because of the importance of manufactures there had long been agitation among various commercial organizations of the United States for the creation of a governmental department for promoting commercial interests; but it was not until 1903 that a bill establishing the Department of Commerce and Labor was passed by Congress; it was approved by President Roosevelt Feb. 14. For the next ten years the joint interests of labor and capital were entrusted to this department. The arrangement proved unsatisfactory because of the frequent conflict of these interests, and in 1913 an independent Department of Labor was created, the name of the Department of Commerce and Labor being changed to Department of Commerce.

**COMMUNISM** (see 6.791).—The term "communism" is used loosely to cover all forms and theories of social ownership of wealth, but has a more specific current meaning to denote the type of revolutionary socialism first expounded in *The Communist Manifesto* of Marx and Engels (1847) and to-day held by the various communist parties that exist in most countries and are united in the Communist International. Communism is thus both an old term and an old theory; but the practice of the Bolshevik revolution in Russia (see BOLSHEVISM) and the subsequent propaganda of the Communist International have given it a significance that is in many ways new.

It is important to distinguish at the outset the various senses in which "communism" is often used, in order to avoid the confusions that beset the term. The English writer, Sidney Webb, has distinguished five senses of communism:—(1) the communism of free use, or "all things in common," as exemplified on a limited scale in public roads and bridges, and as aimed at on a general scale in religious or utopian "communities" of all ages; (2) communism by rationing, or the equal distribution of some particular thing or things among the whole population; (3) communism in treatment, or the supply of some particular service, not equally, but according to need, as in the public provision of medical care or education; (4) communism in the sense of nationalization or municipalization; (5) the communism of *The Communist Manifesto*. To these should possibly be added the anarchistic communism of Kropotkin and his school, to which the name of "anarchism" was formerly given (see 1.914).

It is only the last of the five senses given above (the communism of *The Communist Manifesto*) which will be treated here, since the other senses either do not cover a specific political theory or else are coterminous with Socialism in general. It alone has a continuous history and a present significance.

*Historical Development.*—The conditions which gave rise to communism began with the industrial revolution. The social transformation produced by that event, the emergence of a new middle class and its rise to power, and the creation of a growing town population of wage-earners in large industry, led to numerous movements of unrest in the early 19th century and to all kinds of social theories and questionings. At this time the term socialism became applied to various types of theories of a benevolent or cooperative economic order. These theories, however, formulated mainly by individual thinkers in England and France, had no direct relation to the movement of the masses. The new feature introduced by communism was its direct correlation of social theory with the struggle of the working class. The necessity for this was making itself felt in various quarters; but its first clear expression was given to the world in what is still the classic statement of communism, *The Communist Manifesto* of Marx and Engels, written in Nov. 1847. The year 1847 thus marks the starting-point of communism as a conscious force.

*The Communist Manifesto.*—*The Communist Manifesto* opens with the statement that the history of all hitherto existing human society has been the history of successive class struggles, which have on each occasion either resulted in the revolutionary transformation of society or in its collapse. From the slave systems of ancient civilization to the feudal system of mediæval society, and from that in turn to the rule of capitalism or the bourgeoisie, there has been on each occasion a new class rising to power out of the conditions of the old society after a violent and revolutionary struggle with the preceding class. The rise to power of the bourgeoisie is described in rapid outline, its origin from the bosom of feudal society, its breaking of the bonds of feudalism and monarchy, its revolutionizing of the methods of industry, agriculture and communication, its establishment of modern industry with its accelerated and concentrated production, extended franchise, the national state and the international trade, and finally its subjugation of the whole world to its mode of production. "It has achieved greater miracles than the construction of Egyptian pyramids, Roman aqueducts or Gothic cathedrals; it has carried out greater movements than the migration of peoples or the crusades. . . . Although it is scarcely a century since it became the dominating class, the bourgeoisie has created more powerful and more gigantic forces of production than all past generations put together."

Yet to-day the bourgeoisie finds itself threatened in its turn by the new class of the proletariat or wage-earners which its own method of production has created. Like the systems which preceded it, capitalism has created the forces which, in the communist view, will lead to its overthrow: the proletariat, ever growing in numbers and in the insistence of its demands, and an anarchical system of production leading to periodical crises, unemployment, gluts and overproduction in the midst of famine and misery, and (a modern communist would add) in its last phase the fierce struggles of imperialism and the havoc of world war. It is contended that these contradictions of capitalism reveal that the forces of production have outstripped the existing conditions of social organization, and are producing goods faster than society can control the use of them under the existing laws of property. Social production has been established, but individual appropriation of the results still remain. The contradiction receives expression in the class struggle of the workers against the capitalists. The proletariat, being without property and living in a régime of increasing social production, can no longer fight for individual ownership, but only for the socially conducted utilization of the means of production belonging to the community and of the goods produced: Thus capitalism has created in the

'To explain the "contradictions" of capitalism would demand an examination of Marxian economic theory for which there is here no room. It must suffice to say that Marx saw in the wage system a system by which monopoly in the means of production is used to compel those outside the monopoly (the proletariat) to sell their labour in return for subsistence and forego all rights to the actual value produced. The resulting surplus provides new capital for yet more production on the same system, but always with the need of finding new markets, since the workers themselves, only receiving in wages a portion of the value produced, can only buy back a portion of the value produced; with the result that, while the early stages of capitalism show rapid expansion and development, opening up the whole world and forcing every nation and race into the circle of its operations, the later stages show increasing crises of overproduction and rivalry in markets, tremendous concentration of financial power, and, in the last phase, the continually intensifying struggles of imperialism culminating in world war and world economic disorganization. In this progress capitalism by its own development has completely destroyed the basis of private property from which it began. Originating in private property and competition, it has eaten up the independent small proprietor and replaced him by tremendous combines, replaced competition by monopoly, reduced the masses of the population to the position of a proletariat which in a régime of private property is without private property, and finally reached a stage of production whose forces it is no longer able to control, any more than it can control the proletarian masses who now begin to rise against its domination. Thus all is ready for its dissolution and for the replacement of its worn-out basis of private property by the new basis of social ownership in accordance with the new mode of production and through the agency of the new class the proletariat, which has no knowledge of private property. (For a different view of the capitalistic system, see CAPITALISM.)

proletariat a social class which can only have as its object the abolition of the capitalist system of ownership and its replacement by the proletarian system of common ownership.

But there is this new feature in the struggle and future victory of the proletariat, that, whereas all previous class struggles have resulted simply in the rule of a new minority—the rise to power of a new separate stratum of society—the victory of the proletariat carries with it the emancipation of the whole of humanity, because there is no remaining class below them to be freed. The struggle of the working class is thus the struggle of the humanity of the future, and this is the secret of the class basis of all communist thinking.

It is with this struggle that the communists identify themselves, not as any special party, but simply as the champions of the interests of the working class. They believe that just as each succeeding class has won to power only after violent and revolutionary struggle with the preceding class, so the working class can never realize its aims save by the violent overthrow of the capitalist class and its whole system of power. "The communists disdain to reveal their aims and intentions. They declare openly that their ends can only be attained by the forcible overthrow of every obtaining order of society. Let the ruling classes tremble before a communist revolution; the workers have nothing to lose by it but their chains. They have the world to win. Workers of every land, unite!"

*The Later Period of Marxism.*—In *The Communist Manifesto* may thus be traced all the characteristic conceptions of Marx: the materialist conception of history (not to be confused with either materialism or economic determinism), the doctrine of the class struggle, and the theory of the revolutionary transference of power to the proletariat. At the same time the analysis of the rôle of capitalism, which was to be worked out later with a wealth of detail in the pages of *Capital* (1867), is already briefly indicated, and in a rapid forward glance the prospect is presented of a transition through the revolutionary rule of the proletariat to a classless society. It remained in his later work to give elaboration and precision to these original conceptions in the light of the experience of European history and the working-class struggle for the next generation. These writings have particular reference to two dominant events, the revolution of 1848 which led in Paris to the first distinct attempt of the working class to seize power in "the days of June," with the consequent coalition of all the bourgeois forces into a single "Party of Order," and the Commune of Paris in 1871 when for the first time the working class held power for six weeks. The later developments in Marx's historical and other writings are of especial interest for the new fight they throw on the practical questions of the communist attitude to the State and the conception of the dictatorship of the proletariat (a phrase which did not take shape till after the writing of *The Communist Manifesto*, its first appearance in Marx's writings coming in 1850).

The modern State has already been described in *The Communist Manifesto* as the "executive committee for administering the affairs of the capitalist class as a whole." The experience of the 19th-century revolutions appears to have convinced Marx that it was idle to expect any fundamental change so long as the apparatus of the existing State was left unaffected. Alike in writing of 1848 and of 1871 he stresses the necessity for destroying and shattering the existing machinery of the State. The one and only amendment of substance to *The Communist Manifesto* that he makes in his last preface to it before his death, written in 1872, is to declare that "One thing especially was proved by the commune, namely, that the working class cannot simply lay hold of the ready-made State machinery and wield it for its own purposes." But he demands not merely the destruction of the existing State, but its replacement by a new type of State, a Workers' State or the dictatorship of the proletariat as the transitional organ to carry through the change to communist society:—

"Between capitalist society and communist society there lies a period of revolutionary transformation from the former to the latter. A stage of political transition corresponds to this period, and

the State during this period can be no other than the revolutionary dictatorship of the proletariat." (Critique of the Gotha Programme, 1875.)

This new State will be based on the workers' organizations:—"Against this new official Government," Marx wrote, in describing the tactics for communists during a revolution in its first stages, "they must set up a revolutionary workers' government, either in the form of local committees, communal councils, or workers' clubs or committees, so that the democratic middle class government not only immediately loses its support among the working class, but from the commencement finds itself supervised and threatened by a jurisdiction behind which stands the entire mass of the working class." (Address to the League of Communists, 1850.)

On the other hand the proletarian State is in its nature temporary, because, in proportion as it carries out its task of suppressing class distinctions it destroys its own class basis, and the State as a special organ of class power and coercion gives way to the machinery of a homogeneous communist society. It is only in this second phase of communism that freedom becomes realizable.

*The First and Second Internationals.*—While the main body of communist doctrine was thus receiving its completed form, the first attempts were being made at giving expression to communism in working-class organization. The First International (1864-73) was not a Marxist body; it was a coming together of various types of working-class organization and theory; but from the first Marx played a leading part in it, he drafted its principal declarations, and his ideas became more and more dominant within its ranks, until the controversy with the anarchist Bakunin led to its break-up. The First International was the battle-ground in which Marxism established its supremacy as the social philosophy of the working class. By the time of its demise in 1873 the seed of Marxian socialism had been sown in the working-class movements of Europe.

When the movement towards international working-class organization was resumed with the formation of the Second International in 1889, Marxian socialism was now assumed as the natural basis. Henceforward the class struggle and the transference of power to the proletariat were the statutory objects of international working-class organization. But meanwhile, beneath this apparently rapid victory of Marxism, a deep change in conditions had taken place. The movements that came together in the Second International were no longer the scattered sections of a handful of pioneers in working-class organization. They were powerful national organizations of the workers, numbering their adherents in millions. Thus the second stage had been reached of winning the masses to organization; but the work of training in the principles of the revolutionary struggle still remained. This was the task begun, but never fully achieved, by the Second International, as the war revealed. The peaceful conditions of the period led to hopes of peaceful progress and a gradual transition to socialism without the disastrous necessities of catastrophic change. It was not until the World War, with the collapse that it brought to the ideals of peaceful progress, that communism appeared once more in its full force and with all the revolutionary implications with which Marx had left it.

*The War and Bolshevism.*—The World War, then, is the starting-point of modern communism. The war forced to the forefront in an acute form the issues and divisions that had been latent in the socialist movement. It was no longer possible for the great national movements to maintain their dual allegiance, at once to the existing national State which they hoped some day to control, and to the international class war which they had still continued to proclaim in their resolutions. So there came the division of forces, the division of majority and minority which manifested itself in every belligerent country. The bulk of the official parties supported the war, and in consequence found themselves involved in closer and closer alliance with the Governments. Sections in each country, and in some cases (notably Italy and Russia) the majority, were in opposition.

This division, which began as a difference over the issue of war and peace, soon developed into a deeper opposition. It was not possible for one side to support the war without entering into closer and closer relations with the whole administration of the

existing Governments; it was not possible for the other side to oppose the war without implying a denial of the whole conception of the existing national State. As the division developed, its revolutionary implication became more and more manifest; the Zimmerwaldian organization of anti-war socialists, which had been founded as a temporary substitute for the collapsed International at a conference at Zimmerwald in Switzerland in 1915, gradually evolved from an organ of international peace and working-class solidarity into an organ of international revolution and working-class struggle.

It was the Russian revolution that finally brought this new division to a head. The Russian revolution forced into the realm of actual decision the old controversies of class war or class peace, working-class government or democracy. The party which proclaimed its stand on the Marxian principles of class struggle and working-class government was the Russian Social Democratic party (Majority) or Bolsheviki. (From this title of Bolsheviki, meaning "Majority," derived from their holding the majority at the Brussels-London Conference of the Russian Social Democratic party in 1903, has been formed the word "Bolshevism" as a current popular expression for communism and a loose journalistic term for all forms of extremism and violence.) Against the other socialist sections who maintained a coalition with the bourgeoisie, the Bolsheviki carried through the second revolution of Nov. 1917, and established a new form of government based on the Soviets or workers' councils. With this government they proclaimed the inauguration of the dictatorship of the proletariat, and maintained their power against a series of attacks from without and within. From thenceforward they became the natural leaders of the revolutionary working-class movement of the world. As the revolution spread to other countries, the division in the socialist world became more and more complete, and in 1919 the Third or Communist International was founded on the basis of the revolutionary working-class struggle. The old Marxian term communism was thus revived against the social democracy which Marx and Engels had always declared an unsuitable description for a movement which stood for the suppression both of the State and of democracy, and which the communists regarded as having been a cover for the betrayal of the socialist cause. At the Second Congress in 1920 a detailed statement of communist aims, policy and tactics was drawn up; and communism finally came into existence as a fully organized world force.

*The Modern Communist Outlook.*—The First Manifesto of the new Communist International describes the modern communist outlook. It sees in the ruin of the World War and the peace that succeeded it the fulfilment of the Marxian prediction of the catastrophic destiny of capitalism. Capitalism, it declares, torn by its own contradictions, has plunged into the agony of world war; but war has brought no solution to its problems, just as peace has brought no relief. Hardly has the last war ended before the next war is being prepared; imperialist rivalry continues with more intensity than ever; economic disorganization spreads apace. There is no way out save the complete ending of the system of imperial capitalism that compels these results, and its replacement by the world organization of production on the basis of the workers. "This is the epoch of the decomposition and break-up of the world capitalist system, which will mean the break-up of European culture in general if capitalism with its irreconcilable antagonism is not destroyed." The war has brought the populations of the world face to face with the realities of capitalism: what was before the theory and speculation of a few has become the bitter experience of millions. "The contradictions of the capitalist system were converted by the war into degrading torments of hunger and cold, disease and savagery for all mankind." They have seen the vanity of the hopes of peaceful progress in face of the iron onward sweep to destruction of the existing system. "The catastrophe of imperialist war has with one swoop swept away all the gains of experts and of Parliamentary struggles." Not only the populations of Europe, but the colonial populations of Asia and Africa, have been dragged into the vortex, and are now finding their only chance of libera-

tion in the international communist revolution. In the midst of this world upheaval there is need of a strong revolutionary power that can alone form the coherent force to carry through the necessary change and establish the new system. Reaction solves nothing, and half-measures are fatal. "Only the proletarian dictatorship, which recognizes neither inherited privilege nor rights of property, can shorten the period of the present crisis, and for this purpose will mobilize all materials and forces, introduce the universal duty to labour, establish the régime of industrial discipline, and in this way heal in the course of a few years the open wounds caused by the war and raise humanity to undreamt-of heights." It is the conditions of society that are producing chaos and revolution; it is the object of the communists to end those conditions by giving conscious direction to the instinctive forces of revolt, instead of vainly seeking to stem them. No error, in fact, could be greater than to suppose that the communists are out to "make" a revolution in order to impose their system upon mankind. "The Communist parties, far from conjuring up civil war artificially, rather seek to shorten its duration." In the communist conception the alternative to proletarian dictatorship is not peace. It is war and blockade, famine and disease, blind revolts and the break-up of civilization.

*Communism and Democracy.*—It is from this point of view that the controversy of communism and democracy should be approached if the communist position is to be understood. The communists do not reject the current conceptions of democracy because they believe in the superiority of the few, but because they believe that the phrases of democracy bear no relation to present realities. The divorce between the realities of power and the theory in modern democratic states has been noted by observers of all schools; it is the special point of the communist to insist that this divorce is not due to accidental and remediable causes, but is inherent in the nature of capitalist democracy. Democracy, in fact, is held to be unrealizable in capitalist society because of the fundamental helplessness of the propertyless man; the parliamentary forms only serve to veil the reality of the "bourgeois dictatorship" by an appearance of popular consent which is rendered unreal by the capitalist control of the social structure; and even this veil is cast aside in moments of any stress by the open assumption of emergency dictatorial powers. The plea that this situation may be remedied by education and propaganda is met by the reply that all the large-scale organs of education and propaganda are under capitalist control.

On the other hand communism, while rejecting current democracy, differs from syndicalism and other revolutionary philosophies which proclaim the right of the "militant minority" to endeavour to change society. The glorification of the minority and of the *coup d'état* really belongs to the Blanquist school, which was always vigorously opposed by Marxism. Marxism taught that the liberation of the workers could only be the act of the workers themselves, and that all the communists could do was to endeavour to guide the struggle of the workers into its realization in the dictatorship of the proletariat. In this way the Bolsheviki did not carry through their revolution of Nov. 1917 until they had gained the majority in the Soviets and the trade unions. Where the communists differ from other believers in the ultimate victory of the working class is that they do not believe that victory will be achieved until after a very much more severe struggle than is ordinarily contemplated. They believe that the ruling class will use every means, political, economic and military, to defend its privileges, and that the final decision will not be reached without open civil war. In support of this they quote evidence to show the readiness of the ruling class in many countries to fling constitutional considerations to the winds when their privileges are in danger. To mistake dislike of this prospect for evidence of its improbability they regard as a fatal policy, and they believe it necessary, therefore, to make preparations for the event, considering the best guarantee against the chaos of prolonged social disorder (otherwise inevitable in the period of capitalist dissolution) to be the existence of a powerful revolutionary party. It is this aspect of communism which has led to the current distinction between communism and other forms

of socialism as a difference of method: but it will be seen that this difference of method arises from a far more fundamental divergence in outlook and philosophy. The methods of the communists are not comprehensible save in relation to the whole philosophy of *The Communist Manifesto*.

**Communist Organization.**—From the above considerations certain conclusions follow as to the rôle and character of the communist party in any country. The fully organized communist party, it is stated, is to be the "advance guard" of the working class, never regarding itself as separate from the working class, always working in and through existing working-class organizations on the plane of the struggle of the moment, but always coördinating and giving conscious direction to the different aspects of the working-class struggle with a view to the larger ultimate issue. For this purpose it must be based on the strictest internal discipline, and on severe conditions of membership; but this internal strictness of theory and discipline must be accompanied by an external policy of revolutionary opportunism which is in contrast with the usual "purism" of the revolutionary sect. This is the explanation of the alternate charges of "doctrinarism" and "opportunism" which are levelled by other socialists against the communist party. This discipline is ultimately international in character, because the struggle is regarded as international. To the communist the International is more than a coming-together of sympathetic parties in a common struggle: it is the union of different divisions in a single army, each with its own tactical problems, but all with a single ultimate directing centre. For this reason an absolute ultimate authority is vested in the International Executive, subject to the World Congress. This authority of the International is regarded as of particular importance, not only for the immediate struggle, but as the nucleus of future international authority in the World Soviet Republic.

**Bibliography.**—The classic statements of communism are contained in the writings of Marx and Engels: in particular, *The Communist Manifesto* by Marx and Engels (1848); *The 18th Brumaire* (1852); *Capital* (1867); *The Civil War in France* (1871) and *The Critique of the Gotha Programme* (1875) by Marx; and *The Origin of the Family, Private Property and the State* (1884) by Engels. *The Life and Teaching of Karl Marx* by Max Beer (1918, English translation 1921), gives a valuable short summary of his theories. The controversial literature of Marxism is very extensive, and would need a special bibliography. The most important documents of modern communism are the writings of Lenin, especially *The State and Revolution* (1917) and *Left Communism, an Infantile Disorder* (1920); the writings of Trotsky, including *The Russian Revolution to Brest Litovsk* (1918); Bukharin's *Programme of the World Revolution* (1920), and other writings of the Russian leaders; and the publications of the Communist International, including the *Congress Manifestoes* (1919 and 1920), the *Theses and Statutes of the Communist International* (1920) and the monthly organ *The Communist International*. Presentations by English workers of communist theories may be found in R. W. Postgate, *The Bolshevik Theory* (1920) and E. and C. Paul, *Creative Revolution* (1920). For criticisms of communist theories see Karl Kautsky, *The Dictatorship of the Proletariat* (1919); J. R. Macdonald, *Parliament and Revolution* (1919), and Bertrand Russell, *The Principles and Theory of Bolshevism* (1920). (R. P. D.)

**COMPASS** (see 6.804). In view of the large extension of the field covered by the term "compass" due to the introduction of the "Gyro Compass" and its adoption for navigational purposes, it is essential to define exactly what is meant by a word which is being very loosely applied to instruments of no practical navigational value.

The compass is an instrument designed to seek a certain definite direction in azimuth and to hold this direction permanently. For use in navigation, a compass must satisfy the following practical requirements:—

**Magnetic.**—When disturbed should return to within 1° of the above direction within 2 minutes of time.

**Gyroscopic.**—When disturbed or started should return to within 1° of the above direction within 3 hours.

**Magnetic Compass.**—The description given in the earlier article may be taken as generally applicable to the magnetic compass of the present day; a very great extension, however, in the use of the "liquid" type for nautical purposes has since taken place, while for aeronautical use the liquid compass is essential. The

British Admiralty compass department now occupies the "Compass Observatory" at Langley, Bucks., and deals with compasses of all types both for the Admiralty and Air Ministry. A comprehensive museum is now attached to the observatory.

**Gyro Compass.**—The gyro compass is an instrument in which use is made of the rotation of the earth and the properties of a rapidly spinning body to indicate some fixed direction relatively to the earth. Up to the present the only successful models have been definitely North-seeking, and all such compasses consist essentially of:—

1. A wheel mounted so as to be capable of spinning rapidly without vibration about its axis and also free to point that axis in any direction.

2. A gravity control of some description which restricts the tilting freedom of the axis of the wheel.

Modern gyro compasses differ somewhat in the mechanical devices by which the degrees of freedom of the axis are obtained and in the methods adopted to provide the gravity control; but they are all the practical outcome of experiments made in 1852 by Foucault to demonstrate the rotation of the earth by means of a gyroscope. Edward Sang, of Edinburgh, had described in 1836 how this could be done, but he did not actually carry out the experiment. Much later, in 1884, Lord Kelvin exhibited a model gyro compass before the British Association. Early in the present century the development of submarines called for a non-magnetic type of compass, and fortunately the advance in electrical and mechanical science made it possible for Dr. Anschütz to utilize this pioneer work and evolve the first practical gyro compass. In this instrument a single gyro was used and both the tilting and the azimuthal freedoms were obtained by attaching to the gyro case a float supported in a bath of mercury. A full account of this compass and the elementary mathematical theory of it is to be found in Crabtree's *Spinning Tops and Gyroscopic Motion*. The chief objection to this compass was its failure to function correctly if the ship was rolling, especially when on a quadrantal course. This intercardinal rolling error was, for some time, a stumbling-block to further progress, but in modern gyro compasses it is almost non-existent.

Anschütz in 1912 brought out a very different instrument which was adopted by the German navy. In this model three gyros are used in place of the single one of the earlier model, the two extra gyros having been introduced to overcome the rolling error.

About the same time, the Sperry Co. of New York put on the market their gyro compass. The first model was found, on trial, to be subject to rolling error and this necessitated an alteration in design, a small gyro-pendulum, called the *floating ballistic*, being introduced. This compass, in its modified form, was very largely used by the British and Allied navies during the war.

More recent types are the Brown, Carrie and Twin Sperry. The first is an entirely British-made compass and has many novel features; in particular, the device used to obtain the azimuthal freedom and the gravity control. It is small and light, the whole as fitted in the binnacle weighing about 15 pounds.

Certain very important modifications of the Sperry compasses were developed by the Admiralty compass department as a result of war experience, especially the mercury control attachment invented by Commander G. B. Harrison, O.B.E., and Mr. A. L. Rawlings; this simplifies the construction of the compass, reduces its cost and makes it more efficient, particularly in bad weather (fig. 4).

The most important constants of the Anschütz, Brown and Sperry wheels are as follows:—

	Mass in lb.	Radius of Gyration in inches.	Rate of Spin in r. p. m.
Anschütz . . . . .	6	1.85	20,000
Brown . . . . .	4½	1.57	15,000
Sperry . . . . .	50	4.62	8,600

**Precession.**—So far as gyro-compass work is concerned the phenomenon of precession may be described in the following manner. If a torque is applied to a free gyro in any plane passing through the gyro-axis then the axis will precess in a plane perpendicular to the plane of the torque and also to the plane of the



spin; and the sense of the precession is such that it causes the plane of the spin to move towards the plane of the torque as if to secure agreement of sense after one quarter-turn.

**The Sperry Compass.**—The Sperry type being the most universally known is used in the following discussion as a convenient example to illustrate the principles of gyro compasses. It consists essentially of a gyro mounted so as to be free to spin, free to tilt about a horizontal axis and free to turn in azimuth round a vertical axis. The tilting freedom is modified by the addition of a gravity control in the form of a *bail weight*, fastened to the case by a roller connexion at one point only.

For the present it will be assumed that this roller connexion is in the vertical plane through the gyro-axis, so that whenever the gyro-axis is tilted the gravity control only produces a torque on the gyro in the vertical plane. On account of the earth's rotation the N. end of the gyro-axis will, whenever it is  $\left\{ \begin{array}{l} \text{East} \\ \text{West} \end{array} \right.$  of the meridian be tilting  $\left\{ \begin{array}{l} \text{upwards} \\ \text{downwards} \end{array} \right.$ ; and as a result of the gravity control, whenever the N. end of the axis is tilted  $\left\{ \begin{array}{l} \text{above} \\ \text{below} \end{array} \right.$  the horizontal plane it must be precessing  $\left\{ \begin{array}{l} \text{East} \\ \text{West} \end{array} \right.$ . This precession, however, is relative to space and not relative to the earth.

It follows that such a gyro compass will have, at the equator, a resting-position in which the gyro-axis is horizontal and in the meridian. At a place in N. lat. the gyro-axis, in its resting-position, will be in the meridian with the N. end tilted up slightly, so that the gravity control may provide a torque in the vertical plane sufficient to cause the gyro-axis to precess in azimuth at a rate equal to that at which the meridian is turning round the vertical.

With the Sperry constants the tilt required is about 8' of arc in lat. 53°, for this tilt produces a torque of  $\frac{8}{60} \times \frac{\pi}{180} \times \frac{320}{2}$  ft.-pound-

als and so a rate precession equal to  $\frac{8 \times 160 \times 3600}{60 \times 7 \times 900}$  degrees per hour or about 12° per hour. (Mass of bail = 10 lb.; depth of O. G. below tilt axis = 6 in.)

Further, if the gyro-axis is disturbed from its resting-position it will oscillate about that position but will not settle again unless there is sufficient friction to damp out the oscillations. Such friction must always be reduced to a minimum as it involves a degree of uncertainty in the resting-position.

In order to damp out any oscillations of the gyro-axis the roller connexion between the bail weight and the case is placed slightly to the E. of the vertical plane through the gyro-axis. This roller connexion will, in what follows, be referred to as the "eccentric pivot" With this arrangement whenever the N. end of the gyro-axis is tilted above the horizontal plane there are two torques acting on the gyro, both proportional to the tilt:

- one in a vertical plane as before,
- the other in a horizontal plane.

The second torque is the damping torque and always acts in the sense opposing the precession in azimuth due to the first torque. Its effect on the gyro is always to reduce the tilt whether above or below the horizontal plane. By reducing the tilt it lessens the torque producing the azimuth precession and so diminishes the amplitude of the azimuth movement and consequently damps out the oscillations.

The angle between the two planes through the gyro-axis which pass through the slope diameter and the eccentric pivot respectively is called the *eccentricity of the pivot*, and is usually about 1°. By increasing this eccentricity the damping can be made heavier, the value 7° being enough to give to the Sperry compass a dead-beat movement in all latitudes.

The damping torque causes the compass to settle, in N. latitudes, with the N. end of the gyro-axis tilted up and E. of the meridian. This damping error, or latitude error as it is sometimes called, varies as the eccentricity of the pivot and the tangent of the latitude. In the resting-position the damping torque maintains the slight precession of the gyro-axis in the vertical plane necessary to keep the tilt constant although the axis is not in the meridian.

The resting-position in any latitude can be adjusted to be horizontal and in the meridian by putting out the horizontal balance of the case. Imagine a weight put on the N. side of the case sufficient to produce the torque in a vertical plane required to keep the gyro-axis precessing at the same rate as the meridian is turning round the vertical. Then in the resting-position there would be no tilt and so no pressure at the eccentric pivot, no damping torque and no damping error. That is, the gyro would settle with its axis horizontal and in the meridian. This gives a clue to the effect of a change in the horizontal balance on the resting-position—making this balance N. heavy reduces the upward tilt of the N. end and causes it to settle to the W. of its normal resting-position.

In a similar way can be seen the effect of a twist in the suspension. This merely introduces an extra torque in a horizontal plane and so either increases or decreases the damping torque and therefore the

damping error. Hence the only effect on the resting-position is to introduce a change in azimuth in the sense of the twist.

The preceding remarks refer to a compass in a binnacle fixed relative to the earth. When the binnacle is mounted in a ship further complications arise. That part of the earth's rotation which is essential to the working of a gyro compass is the tilting movement of the horizontal plane about a N.-S. line. This tilting movement in combination with the gravity control causes the gyro compass to be N.-seeking. If the ship, in which the compass is mounted, is steaming due N., the curvature of the earth's surface causes a tilting movement, sense S.-Z.-N., of the horizontal plane about an E.-W. axis; the gyro compass detects this tilting movement and on account of this alone would point its N. end west. The final result is that the gyro-axis points in the direction of the axis of the resultant angular movement. Since the angular velocity of the horizontal plane due to the ship's speed is only a small fraction of that due to the earth's rotation, this direction will be only slightly W. of N. Hence for northerly speeds the compass has a resting-position which is W. of its normal one. This error is called *speed error* and its value in radians is given approximately by the expression

$$\frac{\text{Northerly speed of ship}}{\text{Easterly speed of the latitude circle}}$$

For British latitudes it is roughly 1° per 10 knots. The error for southerly courses is E. and for east or west courses it is zero. Thus it is clear that every alteration of course will involve a change in the resting-position of the compass. Take the case of a ship which, when steaming N. at 20 knots, alters course to S. The gyro compass, supposed settled when the ship was on the northerly course, would be pointing some 2° W. of its normal resting-position; at the end of the turn the new resting-position will be 2° E. of the normal one and so 4° E. of that for the northerly course. But during the turn there has been a southerly acceleration, and consequently a tendency for the bail weight, acting as a pendulum in the N.-S. plane, to lag behind to the north. Hence it exerts a pressure (due to the acceleration) on the case at the eccentric pivot, and so produces two torques on the gyro:

- in a vertical plane sense N.-Z.-S.;
- in the horizontal plane sense W.-S.-E.

The former of these causes the N. end to precess E., that is toward the new resting-position for the southerly speed. The angular displacement of the gyro-axis thus obtained is called the *ballistic deflexion*. If the constants of the compass are so arranged that this deflexion is equal to the difference of the two speed errors, then during the turn the gyro-axis will have moved in azimuth exactly to its new resting-position. But the ballistic deflexion is independent of the latitude, whilst the change of speed error varies with the latitude. Hence this adjustment can only be made correctly in one particular latitude called the *standard latitude*. To obtain this effect the constants of the compass must be adjusted so that its undamped period is 85 minutes in the standard latitude. This is the reason why all gyro compasses of this type have periods approximating to 1½ hours.

The torque in the horizontal plane produces no such beneficial results. It causes an upward precession of the N. end during the turn and so increases the tilt. Since the resting-position for the S. speed requires the same tilt of the N. end as that for the N. speed, the gyro-axis will begin to wander, after the turn is completed towards the west. This wander, called the *ballistic tilt effect*, is always opposed in sense to the ballistic deflexion. It also occurs in the Anschütz and Brown compasses because the acceleration causes a transference of the oil in the damping mechanism. In order to reduce this ballistic tilt effect the eccentricity of the pivot is kept small in the Sperry compass.

The mercury-box attachment to the Sperry compass provides a means of making the ballistic deflexion approximately correct in all latitudes, and is noteworthy as being the only practical device which so far has overcome this difficulty. The gravity control consists of two cast-iron boxes containing mercury, and joined together by a long U tube which enters each box at the bottom. This is essentially a top-heavy form of gravity control and the magnitude of the torque exerted by it depends on the area of the free surfaces of mercury in the boxes. Each box is divided by vertical partitions into three compartments whose areas are as 1:2:3. A valve at the bottom of the box, actuated by turning a knob at one bottom corner, enables the area of the free surface—and so the magnitude of the bail weight—to be varied in the ratio 3:4:5:6. By means of this device the bail weight can be so adjusted that the ballistic deflexion is equal to the change of speed error within ½° in any navigable latitude.

Further complications arise due to the rolling and pitching of the vessel. A swinging ring oscillates stably in its own plane but unstably in a perpendicular plane. This is because the moments of inertia of the ring, about a diameter and about a line through the centre at right angles to the plane of the ring, are not equal. This inequality existed in the original Sperry compass but was removed by the attachment of the compensator weights and frame to the vertical ring. In addition, with the ship on an intercardinal course, say N.E., and rolling, the compass in the binnacle is subject to an alternating acceleration in the N.W.-S.E. vertical plane. The E.-W. component of this causes the compass as a whole to swing in the gimbal in the plane of the case, and so the eccentric pivot swings E. and W.

of its true position relative to the vertical through the gyro-axis. The N.-S. component causes the ball-weight to exert an alternating pressure on the case at the eccentric pivot, first N, then S. These two alterations, the E.-W. swing of the pivot and the N.-S. pressure at the pivot, keep step, and so a torque of invariable sign in a horizontal plane is produced. This causes the gyro-axis to tilt and wander and so introduces *rolling error*. To get rid of this error Sperry aimed at eliminating the E.-W. swing of the pivot by making use of a small gyro pendulum, called the *floating ballistic*, to form the connexion between the ball weight and the case. This fitting gave excellent results except in bad weather; a further modification, obtained by the addition of a frame, carrying a lead weight, to the stem of the pendulum, in order to raise its centre of gravity and so increase its period, produced a great improvement. Even so the compass was not quite reliable in really bad weather, and it was not until the mercury control was fitted that the intercardinal rolling error was finally overcome. In this device the period of the liquid pendulum is so arranged that the forced oscillations of the mercury due to the rolling of the ship are approximately 90° out of phase with the roll, and so complete compensation is obtained.

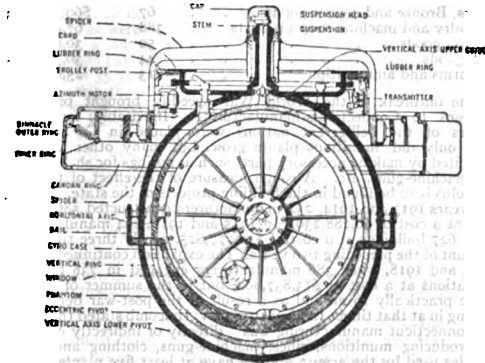

FIG. 1.—Thwartship section of frame. South view of compass.

**Mechanical Operation of the Compass.**—In the Sperry compass a follow-up system is essential to the correct functioning of the master compass; in other types, such as the Brown and Anschutz, this is not the case. The reason for this lies in the different methods of suspension, all of which must be as nearly free from friction as possible, as has been previously stated.

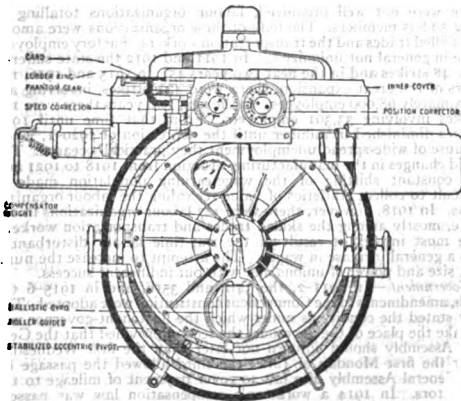

FIG. 2.—Alt view of frame. North view of compass.

The gyro and case in its vertical ring, known as the *sensitive element* (see figs. 1, 2 and 3), is supported from the top of the phantom or follower ring by a wire suspension. The vertical ring is also provided with upper and lower guide bearings in the phantom. These bearings do not support any of the weight, the whole of which is taken by the suspension. Suitable trolley contacts (not shown in

the diagram) are carried on the trolley posts and work over fixed contactors situated opposite them on the upper part of the phantom. The compass card is fixed to the top of the phantom ring and the rack just below it gears into the azimuth motor which is fixed to the frame or *spider*. The trolley and fixed contactors are suitably connected to the relay of the azimuth motor.

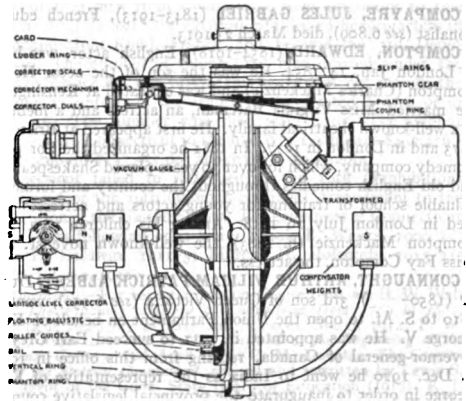

FIG. 3.—Starboard view of frame. West view of compass.

This electrical follow-up system operates so as always to keep the phantom co-planar with the vertical ring. If the gyro precesses in azimuth the trolley wheel is carried to one side or other of the fixed contactor which is insulated in the middle; this operates the azimuth motor through the relay and moves the phantom which carries the compass card, to follow the gyro. On the other hand, when an alteration of course takes place the phantom is at first carried round by the ship until the contacts cause the azimuth motor to drive it back to its normal position in relation to the vertical ring.

In addition to the master compass, which is usually placed more or less centrally in the ship and near the water line, repeater compasses form part of an equipment and may be placed in any convenient position.

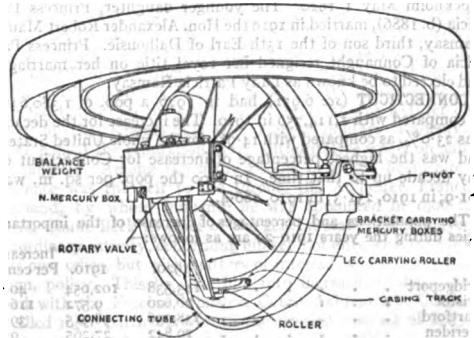

FIG. 4.—General view of mercury control.

They are worked through a transmitter which is operated by a pinion working into the phantom rack just under the compass card. This pinion forms the head of a camshaft which carries three double-faced cams set 60° apart. These cams operate contacts which, using a common return, work the repeater motor. The speed and latitude dials in conjunction with the cosine ring provide an automatic correction for both speed error and damping error, by turning round the lubber ring through an angle equal to the sum of these errors.

As seen from the S. side the direction of rotation of the wheel is clockwise, but this must be reversed when the mercury control is fitted, because this form of gravity control is top-heavy.

**References.**—For a detailed description of the whole equipment and instructions as to the care and maintenance of the Sperry compass, the *Sperry Handbook*, 2nd ed., Feb. 1919, gives full information. This, and a handbook on their Twin Compass, may be

obtained from the Sperry Gyroscope Co., Ltd., 15, Victoria Street, London, S.W. 1, 40, Flatbush Ave., Brooklyn, N.Y., by whose permission their copyright diagrams of the Sperry compass are produced in this article. Messrs. S. G. Brown, Ltd., of Victoria Road, North Acton, have also published a small pamphlet on their compass. Several types of gyro compasses can be seen in operation at the Admiralty Compass Observatory, Langley. (F.C.-O.)

**COMPAYRE, JULES GABRIEL** (1843-1913), French educationalist (see 6.809), died March 23 1913.

**COMPTON, EDWARD** (1854-1918), English actor, was born in London Jan. 14 1854. He was the son of the actor Henry Compton (Charles Mackenzie) and was educated at Kensington. He married Miss Virginia Bateman, an actress and a member of a well-known theatrical family. He first appeared at Bristol in 1873 and in London in 1877. In 1881 he organized the Compton Comedy company, which for over 30 years played Shakespearean and old English comedies throughout the country and formed a valuable school of training for young actors and actresses. He died in London July 16 1918. Among his children were Mr. Compton Mackenzie (b. 1883), the well-known novelist, and Miss Fay Compton, the actress.

**CONNAUGHT, ARTHUR WILLIAM PATRICK ALBERT, DUKE OF** (1850- ), 3rd son of Queen Victoria (see 6.950), went in 1910 to S. A. to open the Union Parliament on behalf of King George V. He was appointed in 1911 to succeed Earl Grey as governor-general of Canada, retiring from this office in 1916. In Dec. 1920 he went to India as the representative of King George in order to inaugurate the provincial legislative councils of Madras, Bengal, and Bombay, arriving at Madras Jan. 10 1921. In various speeches he sounded a note of conciliation with Indian progressive feelings, and it was agreed on his return to England that valuable help had been given by his utterances to the work of self-government in India under the new régime.

The Duchess of Connaught died in London March 14 1917. The Duke's only son, Prince Arthur of Connaught (b. 1883), married in 1913 Princess Alexandra, Duchess of Fife, daughter of the Princess Royal, who had succeeded in 1912 to her father's dukedom by special remainder. Prince Arthur was in 1920 appointed governor-general of the Union of S. Africa. The Duke of Connaught's elder daughter, Princess Margaret (1882), was married in 1905 to the Crown Prince of Sweden, and died at Stockholm May 1 1920. The younger daughter, Princess Patricia (b. 1886), married in 1919 the Hon. Alexander Robert Maule Ramsay, third son of the 13th Earl of Dalhousie. Princess Patricia of Connaught resigned her royal title on her marriage, and elected to be known as Lady Patricia Ramsay.

**CONNECTICUT** (see 6.951) had in 1920 a pop. of 1,380,631, as compared with 1,114,756 in 1910. The increase for the decade was 23.0% as compared with 14.9% for the whole United States, and was the highest percentage of increase for Connecticut of any decade up to that time. In 1900 the pop. per sq. m. was 181.9; in 1910, 231.3; in 1920, 286.4.

The populations and percentages of increase of the important cities during the years 1910-20 are as follows:—

	1920.	1910.	Increase Per cent.
Bridgeport . . . . .	143,538	102,054	40.6
Bristol . . . . .	20,620	9,572	116.4
Hartford . . . . .	138,036	98,915	39.6
Meriden . . . . .	29,842	27,205	9.5
New Britain . . . . .	39,316	43,916	35.1
New Haven . . . . .	162,519	133,605	21.6
New London . . . . .	25,688	19,693	30.7
Norwalk . . . . .	27,700	6,954	299.0
Norwich . . . . .	22,304	20,367	9.5
Stamford . . . . .	35,086	25,138	39.6
Torrington . . . . .	20,623	15,483	33.2
Waterbury . . . . .	91,410	73,141	25.0

**Agriculture.**—In 1900 40.1% of the population was classed as rural by the census; in 1910 34.4%, and 1920 32.2%. The farming population was actually somewhat smaller than even these figures would signify. In 1900 the farms of the state numbered 26,948, in 1910 26,815 and in 1920 22,655, a loss of 4,160 in the latter decade. During the decade 1900-10, the state lost 126,295 ac. held in farms, or 5.5% of the total area of the state. Moreover, 76,273 ac. of improved land, 7.2% of the total, were allowed to go back to forest.

In spite of this decline, the total value of farm property increased by 40.7% during the decade. In 1910 the average value of land per ac. was \$33.03; in 1920 it was \$53.28. The most important crops of the state are hay, corn and tobacco. The rapid growth of the cities has stimulated dairying, market gardening and egg raising. During the World War a Farm Bureau was introduced into each of the counties of Connecticut. It is one of the most important factors in the state, making for better farming and the solution of the local agricultural problems.

**Manufactures.**—Connecticut is one of the preëminent manufacturing states. From 1909 to 1914 the increase in the total of its manufactured products was 11.3%. In 1914 this value was \$545,471,517. Connecticut, although the 46th state in size, was in 1914 12th in the value of its manufactured goods. The *per capita* value was \$454 as compared with \$245 for the United States. In 1914 the state contained 4,104 manufacturing establishments employing an average number of 226,264 wage-earners, and was the 8th among the states in number of wage-earners. The five most important branches of manufacturing were the following:—

Products Manufactured.	No. Establish- ments.	Value of Products.
Brass, Bronze and copper goods . . . . .	67	\$69,353,101
Foundry and machine-shop products . . . . .	388	67,009,127
Cotton goods . . . . .	59	30,808,918
Silk goods . . . . .	4	30,591,825
Firearms and ammunition . . . . .	13	25,657,797

The outbreak of the World War speedily brought profound changes to Connecticut manufacturing. Inevitably, large war orders of the belligerent nations were placed in Connecticut. Not only did munitions plants grow, but many other factories benefited by making accessory parts such as springs for shells, bases for machine-guns, etc. A rough measure of the effect of the new stimulus is to be found in the building projects of the state. During the years 1913 and 1914, 254 manufacturers constructed 386 buildings at a cost of \$6,288,230. In 1915 and 1916, 294 manufacturers built 417 buildings at a cost of \$18,277,822, nearly three times the amount of the preceding two years. The expansion continued during 1917 and 1918, when 386 manufacturers engaged in 738 building operations at a cost of \$13,837,802, but in the summer of 1920 it came practically to an end as a result of the post-war depression setting in at that time. In May 1918 Gov. Holcomb stated that 80% of Connecticut manufacturing was "directly or indirectly engaged in producing munitions, rifles, machine-guns, clothing and other articles used by the army; and we have at least five plants within our borders where ships and power-boats are being constructed." With the signing of the Armistice and the cancelling of war orders, Connecticut factories began to reorganize. The readjustment to a peace footing was made easier by the great demand for manufactured goods that characterized the year 1919, and had been practically completed throughout the state when the depression of 1920-1 brought a considerable slowing up of productive effort. The growth of manufacturing, coupled with the increase in the cost of living that followed the outbreak of the World War, brought labour troubles to Connecticut. Before the war the wage-earners of the state were well organized, labour organizations totalling in 1912 89,895 members. The bulk of these organizations were among the skilled trades and the transportation workers. Factory employees were in general not unionized. In 1911 and 1912 the state suffered only 48 strikes and in the next two years 45. In 1915 and 1916, the years of the great expansion, there were 422 strikes, involving approximately 68,000 employees. In the next two years there were 183 strikes involving 33,391 employees. From that time until 1921 strikes diminished in number until the depression of 1920-1, when because of wide-spread unemployment they practically ceased. The rapid changes in the manufacturing situation from 1918 to 1921 and the constant shifting of the wage-earning population made it difficult to collect statistics of value regarding the labour organizations. In 1918, however, there were 327 labour organizations in the state, mostly among the skilled trades and transportation workers. The most important result of the war-time labour disturbances was a general increase in wages. The attempt to increase the number, size and power of unions met with but indifferent success.

**Government.**—In 1911-2, the 34th and 35th, and in 1915-6 the 36th, amendments to the Connecticut constitution were adopted. The first stated the conditions under which the lieutenant-governor was to take the place of the governor; the second provided that the General Assembly should adjourn not later than the first Wednesday after the first Monday of June; the third allowed the passage by the General Assembly of a law to cover payment of mileage to the legislators. In 1914 a workmen's compensation law was passed, which applies to all industries in which five or more persons are employed. Compensation for total disability is one-half the employee's weekly wages, compensation to be not less than \$5.00 nor more than \$14.00 per week, and in no case to run for more than 390 weeks; compensation for partial temporary disability not more than half the weekly wages, compensation not to run more than 112 weeks; permanent partial disability, at same rates; in case of death, graded benefits. The law is enforced by Compensation Commissioners.

appeals from whose findings may be made to the superior court of the county. In the physical examinations for the draft during the World War, 20.79% of those examined were disqualified for physical disability, Connecticut being the seventh highest state in this percentage. On investigation it was found that many of the disabling disorders were due to preventable conditions in childhood. The result was the appointment of a commission to report a programme for child welfare. The commission reported in 1921. It was found at the same time that 37.21% of all Connecticut registrants under the draft law were aliens. Only one state had a higher percentage. The result of this situation was a vigorous movement for the Americanization of aliens.

**Education.**—Beginning July 15, 1909, the organization of public education changed from the district type to that of town management. There were in 1921 less than ten townships in the state that had not availed themselves of the law. Under township management all schools of the township are under the direction of the town school committee. Appropriations for the support of the schools are made at a town meeting. The plan has resulted in better and more uniform advantages for school children. Compulsion was made more rigid by the enactment providing that after Sept. 1, 1911 no employment certificate of any description could be accepted by any employer except such as were issued by the State Board of Education. On July 1, 1917 a law went into effect providing that all new public-school teachers pay annually 5% of their salary into a pension fund. At the end of 35 years (changed to 30 in 1919), the last 15 of which must be within the state, or on reaching the age of 60, the teacher might retire and receive the annuity which his or her contributions and accrued interest would warrant. To this the state would add as a pension a sum equal to the annuity. Special provisions were made to apply to public-school teachers already in service at the time of passage. In 1911 a charter was granted for a woman's college at New London, and in 1914 it was opened as the Connecticut Woman's College, with Dr. F. H. Sykes as president.

In 1920 the corporation of Yale University announced the establishment of a Department of Education in the graduate school, designed among other things to train "superintendents, supervisors, principals, directors of special activities, research specialists, normal and college instructors in education and class-room teachings." For further information regarding YALE UNIVERSITY, see that heading.

**History.**—In 1913 it became known to the public that the financial condition of the New York, New Haven, and Hartford railway was unsound. The dependence of the people of the state on the road was made clear by a statement of the road's president, Mr. Howard Elliott, that in 1913 the road controlled 94.2 of the 1,000 m. of steam railroad in the state, and in addition was interested in separately operated trolley lines aggregating 605 m. out of a total of 911 miles. This dependence was augmented by the fact that (to quote Gov. Holcomb) "the securities of this corporation are quite largely owned and held by women and children, in trust funds, and by our insurance companies who purchased them as a safe, conservative investment." The change in the financial affairs of the railway brought its stock rapidly from far above par to much below. The suffering caused was general and very considerable. Public opinion forced a change of management.

When the United States was finally compelled to sever diplomatic relations with the Imperial German Government (Feb. 3, 1917), Gov. Holcomb requested the Legislature (Feb. 6, 1917) to provide for a census of men of military age, the object being to determine not only the number of such men but their occupations, previous military training, nationality and whether or not they were citizens. It was the pioneer military census within the United States and served as a model for those of other states. The Home Guard of Connecticut, formed March 9, 1917, rose to 10,000 men. During the summer of 1917 the 26th Division was organized from the New England National Guard. Of the units in that organization the following came from Connecticut: the 1st and 2nd Conn. Infantry became part of the 102nd Infantry; two batteries of Conn. Field Artillery became part of the 103rd Field Artillery; the Conn. Cavalry became part of the 101st Machine-Gun Battalion; and the 1st Conn. Field Hospital and 1st New Haven Field Hospital became part of the 101st Sanitary Train. The division established its headquarters in France at Neufchâteau, Oct. 31, 1917. It participated, among other actions, in the Aisne-Marne, the St. Mihiel and the Meuse-Argonne offensives. During the formation of the 26th Division, preparations were being made for the National Army. The 1st Provisional Training Regiment was organized at Plattsburg,

N. Y., May 15, 1917. To this regiment Connecticut sent her officer candidates to train for commissions. On Aug. 25, 1917 the 76th Division was organized at Camp Devens, Ayer, Mass., its officers below the rank of lieutenant-colonel being drawn almost entirely from the 1st Provisional Training Regiment. The bulk of the drafted men from Connecticut went originally to this division. In July 1918 the division established headquarters in St. Amand-Mont-Rond, France, and became the 3rd Depot Division. The number of Connecticut men drafted under the Selective Service Act was 34,574; this figure does not include the numerous volunteers in the armies of the United States or of the Allies. The number who died were 1,505. The amount subscribed by Connecticut in the five War Loans was \$437,476.103, an amount \$137,557,803 above the state's quota.

Connecticut failed to ratify either the 18th (Prohibition) Amendment or the 19th (Woman Suffrage) Amendment to the Constitution of the United States. The governors of Connecticut in the years following 1909 were: Frank B. Weeks, 1909-11; Simon E. Baldwin, 1911-15; Marcus H. Holcomb, 1915-21; Everett J. Lake, 1921-.

**Bibliography.**—For recent works on Connecticut see H. W. Waldradt, *The Financial History of Connecticut from 1789 to 1861*, Connecticut Academy of Arts and Sciences, March 1912; P. W. Bidwell, *Rural Economy in New England at the Beginning of the Nineteenth Century*, *ibid.* April 1916; C. M. Douglas, *The Government of the State of Connecticut*, revised and rewritten by Lewis S. Mills, agent of the Conn. State Board of Education (1917); R. J. Purcell, *Connecticut in Transition* (1918); C. M. Andrews, *The Fathers of New England and Colonial Pathways in The Chronicles of America* (1919); M. Newcomer, *Separation of State and Local Revenues in the United States* (a comparative study of eight states, including Connecticut) (1917); H. Elliott, *Connecticut and the New Haven Road* (1913). (R. H. G.)

**CONRAD, JOSEPH** (1856- ), English novelist (see 6.968). Later work includes a study of the revolutionary temperament, *Under Western Eyes* (1911); an autobiographical set of *Reminiscences* (1912); three volumes of short stories, *Twixt Land and Sea* (1912), *Within the Tides* (1915) and *The Shadow Lines* (1917); as well as 4 novels, *Chance* (1914); *Victory* (1915); *The Arrow of Gold* (1919) and *The Rescue* (1920). A dramatized version of *Victory* was played at the Globe theatre, London, in 1920.

**CONRAD VON HÖTZENDORF, COUNT** (1852- ), Austrian field-marshal, was born at Vienna, and after graduating at the military academy of Wiener Neustadt entered the army as lieutenant in a Jäger regiment. He was appointed to the general staff, and distinguished himself during the fighting in Bosnia and Herzegovina in 1878 and 1881. He continued to be employed mainly on the general staff, especially as lecturer on tactics in the Kriegsschule (the highest military academy), and he gained the reputation of an authoritative writer on military subjects. Among the many people in whom he inspired confidence was the heir to the throne, the Archduke Francis Ferdinand, by whose influence he was appointed in 1906 to succeed Count Beck as chief of the general staff. He displayed extraordinary activity, concerning himself not only with the work of his own office, but with matters of internal, and still more of foreign, policy. This brought him into increasingly sharp discord with the Foreign Minister, Count Aehrenthal. Conrad was filled more particularly with the deepest distrust of Italy, and, convinced as he was that it would be impossible to avoid a struggle for the very existence of the Habsburg Monarchy, he wished to precipitate this struggle while the chances were not unfavourable. The latent opposition between the two men led to Conrad's temporary retirement in 1911. At the end of 1912 he was recalled to his post and in 1914 agreed to the military measures against Serbia which led to the World War. For more than two years of the war he was the real leader of the Austro-Hungarian armies. Though he was not always successful in the unequal struggle, the essential credit of the great success at Gorlice (1915) must be ascribed to him. To him also are due a series of successful operations, although a decisive victory was denied him. In 1917 he assumed the command of the forces operating in Tirol, and took part in every engagement until the battle of the Piave in the summer of 1918. After this he retired from

active service, was raised to the rank of count, created a field-marshal, decorated with numerous orders, and appointed commander of the Imperial Guard. Conrad was one of the most predominant personalities of the fallen monarchy, whose fate he was unable to avert. In his active military operations his most distinguished colleague was Gen. Metzger (b. 1870), who, after Conrad's retirement, took over a high command, distinguishing himself on the Italian front and finally in France in coöperation with the German armies. (A.—K.)

**CONS, EMMA (1838-1912)**, English philanthropist, was born in London March 4 1838. As a young woman she studied art, but, owing to an acquaintance with Miss Octavia Hill, became interested in social work, and in particular in questions of housing. She became best known, however, for her work in connexion with Morley College and the Royal Victoria Hall, Waterloo Road, generally known as the "Old Vic." At one time a well-known theatre, it had degenerated into a disreputable haunt where nothing but the lowest melodramas were played. Miss Cons, whose social work in Lambeth had made her well acquainted with the difficulties of providing decent amusement at a cheap rate for the people of the neighbourhood, obtained an interest in the building about 1880. It was enlarged and improved, the sale of drink was forbidden, and miscellaneous programmes of music, drama, and lectures were embarked upon. In 1882 the wealthy manufacturer and philanthropist Samuel Morley began to take an interest in the affairs of the Hall, and in 1884 he joined the executive committee. He contributed a large amount of money to the scheme, and his unflinching sympathy and practical business advice were of the greatest value. His death in 1886 was a great blow to the work, but his name has been perpetuated in the foundation of the Morley College for working men and women, which developed from the lectures given at the "Old Vic." Its first vice-principal was Miss Caroline Martineau, a friend and co-worker of Miss Cons, and the institution now has over a thousand members. Miss Cons's work bore fruit after some years in the excellence of the entertainment provided and the high repute which the "Old Vic" attained. In 1889 concert performances of grand opera were started, and in 1896 a chorus was formed, thus making it possible adequately to present the operas. In 1905 symphony concerts were embarked on, and continued for several seasons. Miss Cons was elected to the first London County Council (1888), and was chosen an alderman, but retired owing to difficulties raised as to the right of women to sit. She died at Hever, Kent, July 24 1912.

Her sister, **ELLEN CONS (1840-1920)**, was also closely associated with many philanthropic schemes, and was one of the governors of the "Old Vic." She died in London June 25 1920.

**CONSERVATION POLICY.**—The name "Conservation" has been given in the United States to the movement for using and safeguarding the natural resources of the country (or indeed any country) for the greatest good of the greatest number of the inhabitants for the longest time. It is a fundamental misconception to suppose that Conservation means nothing but the husbanding of resources. The first principle of Conservation is use, but it refuses to recognize needless waste and destruction as normal processes in the proper development and enjoyment of natural wealth. This conception of Conservation as a principle to be followed by the American Government was first brought into prominence by the Chief Forester of the United States during the Roosevelt administration, and was first applied to forest protection.

As with all nations that are both rich and young, a general indifference to the protection and preservation of its natural resources had marked the history of the United States. The rapid and reckless destruction of the forests was the first cause of a change in the attitude of the American people toward natural wealth. Effective action toward the protection and preservation of natural resources was not taken until long after the early warnings, which were heard nearly a century before the Conservation movement was born. In 1819, more than three score years before forestry had secured a foothold in America, a French naturalist, André François Michaux, in his work *The*

*North America Sylva*, spoke thus of the destruction of forests in America:—

"... neither the Federal Government nor the several states have reserved forests. An alarming destruction of the trees proper for building has been the consequence—an evil which is increasing and which will continue to increase with the increase of population. The effect is already very sensibly felt in the large cities, where the complaint is every year becoming more serious, not only of excessive dearth of fuel, but of the scarcity of timber. Even now inferior wood is frequently substituted for the White Oak; and the Live Oak, so highly esteemed in ship-building, will soon become extinct upon the islands of Georgia."

Conservation, as an American problem, received its first recognition in the work of the Inland Waterways Commission. On Oct. 3 1907 this commission suggested to President Roosevelt, who had created it, the calling of a conference of governors to consider the condition of the natural resources of the United States. The conference assembled May 13 1908 in the White House at Washington. Among those in attendance were the President, the Vice-President, 7 of the 9 members of the Cabinet, the 9 justices of the Supreme Court, the governors of practically all the states and territories (including Alaska, Hawaii, and Porto Rico), numerous members of the Senate and the House of Representatives, representatives of 68 national societies, more than 50 citizens selected for their special attainments, and the members of the Inland Waterways Commission. This was the first time the governors of the states met in conference, and the gathering was unique in American history. The conference, after deliberating for some days, adopted a declaration containing the following passage:—

"We agree that further action is advisable to ascertain the present condition of our natural resources, and to promote the conservation of the same: and to that end we recommend the appointment by each State of a commission on the natural resources to co-operate with each other and with similar commissions of the Federal Government."

In accordance with this recommendation, the governors of 47 states promptly appointed state conservation commissions, and less than a month after the conference had closed President Roosevelt appointed a National Conservation Commission, divided into four sections dealing respectively with water, forests, lands and minerals. The commission was directed by the President to investigate and report to him regarding the condition of the natural resources, and to recommend to him measures for conserving them. As the commission had no funds at its disposal, the President directed the heads of departments at Washington to place their officers and facilities at the service of the commission. Thereupon the commission undertook, for the first time in the history of any nation, to prepare an inventory of the natural resources of the country.

The report of the commission was presented to the President in Jan. 1909, and was by him transmitted to Congress with a special message concurring in its statements and conclusions, and recommending it to the consideration of Congress and of the people generally. After making its report the commission continued its efforts in coöperation with governmental and extra-governmental agencies for the conservation of natural resources in order both to extend its inventory and to determine what specific laws were needed for the wise and orderly development of the country's natural wealth. Unfortunately, this constructive work was stopped by the abolition of the commission through a law enacted by Congress later in the same year. Meantime President Roosevelt had invited the governor-general of Canada, the governor of Newfoundland and the President of Mexico to appoint commissioners to discuss, with commissioners representing the United States, the principles of conservation in their application to the continent of N. America. As a result of this movement, the first N. American Conservation Congress was held in Washington in 1909. President Roosevelt in Feb. 1909, after consulting the Queen of the Netherlands, invited the powers of the world to meet at The Hague for the purpose of considering the conservation of natural resources everywhere. Although a majority of the nations accepted this invitation, the project, after President Roosevelt's retirement from the presidency,

was allowed to die. During the administration of President Taft the struggle for conservation centred in the so-called Ballinger-Pinchot controversy, the cause of which was an effort on the part of Richard Achilles Ballinger, then Secretary of the Interior, to transfer to private ownership certain valuable coal lands in Alaska, and to throw open to private acquisition highly valuable water-power sites upon the public lands which had been set aside by President Roosevelt. The controversy resulted in the resignation of Mr. Ballinger, and had much to do with the defeat of President Taft in the election of 1912. The coal lands and water-power sites which formed the subject matter of the dispute remained in the public hands.

In the effort to secure the use of the natural resources so as to promote the greatest good to the greatest number for the longest time, President Roosevelt, in support of legislation by Congress to that end, withdrew from private entry 148,000,000 ac. of forest land, 80,000,000 ac. of coal land, 4,700,000 ac. of phosphate land, and 1,500,000 ac. containing water-power sites on the public lands. Thus during the Roosevelt administration more than 234,000,000 ac. of land were preserved, most of which will probably be permanent property of the nation.

Because of the abolition of the National Conservation Commission, the movement threatened to be seriously hampered by the lack of a central body in which could be conjoined for united and effective action the many persons and agencies devoted to the movement. Accordingly, the National Conservation Association, whose purpose was to inform and give effect to public sentiment, was established in 1909. In its successful efforts to prevent the passage of bad laws and to secure the enactment of good laws, this association became an effective factor in the passage by Congress of measures that carry out the Roosevelt policies of Conservation. The more important of these measures are: the Weeks law, to purchase lands for national forests in the White Mountains and the Appalachian Mountains where there was no public land; the Coal and Oil Leasing bills (for the continental United States, including Alaska) which are securing conservation by wise use, without waste and without monopoly, of valuable resources still in the public hands; and the Federal Water-Power Act, to provide for the development by private enterprise, under Federal ownership and control, of water-power in the public domain and navigable streams. Here again public property worth thousands of millions of dollars has been saved for the benefit of all the people of the United States. The association has been especially influential in defeating legislation that sought to destroy the national forests and to permit the diversion to private ownership of natural resources.

The Conservation movement is probably, among the many constructive policies inaugurated by President Roosevelt, that which will be most influential for good, and for which he will be longest remembered. (G. P.)

**CONSTANS, JEAN ANTOINE ERNEST** (1883-1913), French statesman (see 6.986), resigned from the embassy at Constantinople in May 1909. His success as a diplomat was less marked than as a minister. Presenting himself for the Senate (for Aveyron) in 1912 he was defeated. He died April 7 1913.

**CONSTANTINE**, King of the Hellenes (1868- ), eldest son of George I. of Greece, was born Aug. 2 1868, and succeeded to the throne March 18 1913, on the assassination of his father. As the first prince of a Greek reigning dynasty born in modern times on Greek soil, and reared in the Greek Orthodox faith, he became from his birth to the Greek people the embodiment of their national aspirations, and was given the name of the last Emperor of Constantinople, in the superstitious hope that he would fulfil the old prophecy that the Empire of Byzantium would be restored to the Greek nation, when a king named Constantine and a queen named Sophia should reign on the Greek throne. This strange legend strengthened Constantine's popularity amongst the Greeks, and when in 1889 he married Sophia Dorothea of Hohenzollern, daughter of the Emperor Frederick of Germany, the coincidence of the name enhanced immensely the superstitious belief of the Greeks. He received his early education under private tutors at Athens. At the age

of 18 he was sent to Berlin for a military education, and served in one of the Imperial Guard regiments, attending also a few desultory courses at the university of Leipzig. It was during his stay in Berlin that he made the acquaintance of his future wife, and (very much against his father's wishes) formed the attachment that was destined to exert such an important influence on his career.

After returning to Greece he was given various military commands. In 1897 he was sent to Larissa to take command of the Greek army in Thessaly, just before the outbreak of the disastrous war with Turkey. At the close of the war the Crown Prince was probably the best-hated man in Greece. The popular voice attributed the disasters to him and to his father. He still retained, however, his nominal post of commander-in-chief.

It was only in Aug. 1909, when the garrison of Athens suddenly revolted and demanded sweeping reforms, including the reorganization of the army and navy and the removal of the princes from all military commands, that Constantine and his brothers, George, Nicholas and Andrew, hastened to resign their commissions and to go abroad to escape the open hostility of public opinion. From this practical exile the Crown Prince first, and his brothers Nicholas and Andrew afterwards, were recalled and reinstated in their commands by Venizelos, when the latter became the all-powerful head of the Greek Government. His bill for the reappointment of Crown Prince Constantine as commander-in-chief of the army was bitterly opposed in the Greek Chamber by Theotokis, Gounaris, Rallis and other politicians, who a few years later were to become King Constantine's chief supporters. The army officers, too, with few exceptions, were much opposed to the bill. By a curious irony, it was only Venizelos' determined attitude that saved it from rejection. The Greek successes in the Balkan wars subsequently enhanced the Crown Prince's credit, and it was in an atmosphere of renewed popularity (Venizelos himself helping to exploit it) that he succeeded unexpectedly to the throne on his father's assassination.

King Constantine at once showed his monarchical spirit. He took to copying the modes of speech and action of his brother-in-law, the German Emperor. He began to speak, in his official utterances, of "My army" and "My navy"; to attend in person the swearing-in of the annual recruits and to impress upon them the extreme sanctity of their oath of allegiance to him. Officers were made to feel that their only hope of advancement lay in their devotion to the War-lord. And when his youngest daughter was born in 1913, he proclaimed "his" army and navy godfathers to the little princess. Such incidents attracted little serious attention at the time. But the subsequent course of events showed that the King was intent on converting the democratic, ultra-constitutional monarchy, which that of Greece had been, into one of a more absolute type on the Prussian model. Constantine and his defenders have indeed vehemently denied the existence of any secret understanding between himself and the Kaiser, either before or after the outbreak of the World War. Apart, however, from the indirect evidence furnished by the private telegrams exchanged between the royal couple of Greece and the Kaiser in 1916-7, which came to light after Constantine's dethronement, the existence of a definite understanding between William II. and Constantine to secure Greek neutrality in an impending European war has been expressly attested by Gen. Ludendorff himself in his war memoirs. During the first six months of the war Constantine gave no sign, even when Venizelos, before the first battle of the Marne, offered the alliance and aid of Greece to the Entente Powers. But when in Jan. 1915 the Entente promised Greece extensive territory in Asia Minor if she would join in the Dardanelles operations, and Venizelos proposed to cooperate, Constantine refused to give his sanction. Venizelos at once resigned, and at the ensuing parliamentary election a large Venizelist majority was returned (June 1915). The King was seriously ill at the time, and the Queen and the Government flatly refused to allow the appointment of a regent. Thus it was a full three months after the election before Venizelos



returned to power; thus that interval every effort was vainly made by Court and Cabinet to seduce the Venizelist deputies into joining the "King's party," as it was now openly termed. When Venizelos finally was reinstated in office Bulgaria was preparing to fall upon Serbia in the flank, and Venizelos hastened to inform Bulgaria that any attack by her upon Serbia would cause the intervention of the Greek army. But Constantine, sending for the Bulgarian minister behind Venizelos' back, authorized him to inform his Government confidentially that Bulgaria need not fear any intervention on Greece's part. He gave the same assurance through the channel of the German Government. Thus Bulgaria proceeded unhesitatingly to order a general mobilization (Sept. 1915). To this step Venizelos at once replied by ordering a general mobilization of the Greek army. The King offered no objection to signing the decree, but when the next day Venizelos announced in the Greek Chamber that Greece would declare war against Bulgaria if she attacked Serbia, Constantine immediately sent for him and asked for his resignation, informing him that he would never consent to attack one of Germany's allies. To Venizelos' remonstrance that after the recent popular verdict the Crown was bound to follow the responsible Government's policy, Constantine replied that in questions of foreign policy he did not hold himself bound to follow the popular will, as he considered himself "personally responsible to God alone." Thus, after Venizelos' fresh resignation and the formation of a Zaimes Cabinet, the Greco-Serbian treaty was repudiated and Serbia was abandoned to her fate. As the Venizelist parliamentary majority refused to support the new Government a fresh dissolution was decreed, and in the new election (Dec. 1915), owing to the Venizelist party abstaining as a protest against the repeated unconstitutional proceedings of the Crown, a new Chamber was elected, composed entirely of Constantine's supporters. At Venizelos' invitation just before his resignation an Anglo-French force of over 100,000 men had been landed at Salonika, too late indeed to save Serbia but strong enough to entrench itself at Salonika.

Constantine and his party did not yet dare to commit themselves to a policy of open hostility to the Entente, although the Greek army, mobilized by Venizelos to defend Serbia, remained under arms in Macedonia until July 1916 to "defend Greek neutrality." But the Allied army in Macedonia was subjected to every sort of petty annoyance and even to espionage on the part of the Greek authorities; thus a Greek lieutenant, who was accused of tapping the Allied military telephone wires, was ostentatiously decorated by the King within the week. On May 26 1916, by direct order of Gen. Doumances, the King's chief-of-staff, over the head of the responsible Minister of War, Fort Rupel, which commanded the Struma Pass into east Macedonia, was surrendered to the Bulgarians by pre-arrangement between Constantine and the German general staff.

After Venizelos had seceded from Athens and established his "Provisional Government of National Defence" at Salonika, Constantine's movements became more and more openly hostile to the Entente. Regular communications with the Central Empires were kept up through north Epirus and Albania, and the German-Austrian submarines were suspected of receiving valuable assistance from royalist agents in Greece. Finally, Constantine's troops having become a standing menace to the Allied army in Macedonia, the Allies demanded the surrender of a quantity of arms and ammunition on the part of the Athens Government. The Lambros Ministry protested against this demand, but the King privately promised the French admiral, Dartige du Fournet, to surrender these arms if Athens were occupied by an Allied force to "save his face." When, however, on the following day (Dec. 1 1916) a body of 1,800 Allied blue-jackets landed at the Piræus and marched up to Athens, they were allowed to walk into positions carefully ambushed, and there were set upon by the royalist troops and thousands of reservists specially enrolled and armed for the purpose overnight. The Allied force drew off at nightfall with heavy losses. They would have been annihilated but for the presence at

Phaleron of a powerful Allied fleet, which late in the day hurried a few shells into the royal palace and caused Constantine to order a cessation of hostilities.

This act of treachery on Constantine's part was followed the next day by wild scenes of hunting down as rebels and enemies of the King the unarmed Venizelist citizens of Athens. But the Powers took no immediate steps either to protect their friends or to avenge the insult to their own flags. After a whole month of deliberation, on Dec. 31, they declared a blockade of Greece and demanded the removal of the entire Greek army to the Peloponnese. But no measures were taken against Constantine himself, since apparently there were still quarters within the Entente unwilling to believe the worst. It was only on the downfall of the Tsar (March 1917) that Great Britain and France finally arrived at a decision. On June 11 1917 a powerful Anglo-French fleet arrived at the Piræus, carrying a land force of 30,000 men; and M. Jonnart, in the name of the Allies, demanded the immediate abdication of Constantine and his eldest son and their departure from Greece. Constantine saw that resistance was hopeless and bowed to the inevitable. Constantine (or "Tino," as he was commonly called) withdrew to Switzerland; there, with the aid of the German propaganda, he organized intrigues in Greece among the disaffected. He went so far in 1918 as to send his chief aide-de-camp to Germany to select two officers of the Greek army corps of Kavalla, then interned at Görlitz, to proceed to Greece on board a German submarine, to spy upon the Allied army in Macedonia and to organize an armed uprising in their rear. And he openly proclaimed *urbis et orbis* that he had never renounced his rights to the Greek throne and was still the only legitimate sovereign, his son Alexander (who had been proclaimed the new king) being merely his temporary *locum tenens*. Thus it came about that upon Alexander's untimely death and Venizelos' defeat at the polls in Nov. 1920, Constantine returned in triumph to Athens, in defiance of the Allies' non-recognition of him. He was not recognized in 1921 by any of the Allied Powers. On June 11 1921 (still without any formal recognition from the Allies) he left for Smyrna to take command of the Greek army in Asia Minor in the renewal of war (England and France standing aloof) against Turkey.

**CONVOY** (see 767).—The system of convoy adopted by the British and American navies in 1917, by which merchant vessels sailed in organized groups under naval escort, played an important part in the World War. In the following account it should be noted that the term is used in the British Admiralty sense to signify not only the system but also the merchant ships under escort; in the U.S. navy the warships are the escort, the merchant ships the "train," and the whole is the convoy.

At the beginning of the war the British system of commerce protection was based on cruiser squadrons stationed at the focal points of trade and in important areas to deal with enemy cruisers and raiders. Though it proved sufficient to accomplish the destruction of the "Kaiser Wilhelm der Grosse" and the "Cap Trafalgar," the principal cruiser raiders escaped its clutches; for the "Emden" was sunk by the "Sydney" escorting a convoy at the time, the "Karlsruhe" was blown up by an internal explosion and the "Dresden" was sunk by a squadron detached for that purpose. From the first the system had been dislocated in every sea by demands for convoy, but by March 1915 the cruisers had been run to earth, and though raiders such as the "Moewe" and the "Wolf" reappeared, it was only occasionally and one at a time. The system of convoy was used in the case of the first large contingents of Australian and Canadian troops. The "Sydney" with the "Melbourne" and the Japanese cruiser "Ibuki," was escorting the Australian convoy across the Indian Ocean when she was detached to run the "Emden" down at Cocos I. on Nov. 9. The first Canadian contingent of 37,000 men which sailed from Quebec on Oct. 3 1914 in 32 transports was escorted by the cruisers "Charybdis," "Diana," "Eclipse" and "Talbot," reinforced, as they approached British shores, by the battle cruiser "Princess Royal" and the old battleship "Majestic." The system was

\* These figures indicate the volume and page number of the previous article.

resumed in the Atlantic in 1916 when the "Moewe" was out, and in the course of that year some 15 convoys of two to three transports each sailed from Halifax. But these were special escorts intended to protect their convoys from surface craft. The adoption of a general convoy system was still outside the pale of contemporary naval thought. A considerable proportion of the troop service across Channel was escorted; but this was a local service arranged by the admirals at Dover (for Folkestone to Boulogne) or Portsmouth (for Southampton to Havre). There was a tendency to regard the loss of merchant ships with little concern during that period, and a number of large ships were even fitted out at great expense to act as dummy battleships to be torpedoed by the enemy instead of the vessels they tried to counterfeit. The idea of using destroyers to escort the ordinary trade would have received short shrift at the Admiralty and in the Grand Fleet, nor was it necessary at the time.

In March and April 1917, when the British losses in merchant shipping assumed alarming proportions, the idea of a convoy system came again to the front. Previous ocean convoys had been directed against the surface raider; it was the submarine that now formed the principal menace. The system was in use in the case of what was called the French coal trade, a cross-Channel traffic from Portsmouth and Falmouth performed by small ships, where it had worked very successfully, and it was now suggested to extend it to the ocean routes. The system of protection in vogue at the time may be called the patrolled route system. There were three main approach routes to the British Isles, one N. of Ireland for ships making the Clyde or Liverpool by the North Channel (Route C); one S. of Ireland for ships making the Bristol Channel and Liverpool by St. George's Channel (Route B); one towards the Scillies for ships making the English Channel (Route A). These were called the Tory I., Fastnet (S.W. point of Ireland) and Scillies approaches, from the lights sighted by the ships as they made the coast. These approaches may be regarded as three great triangles gradually narrowing to three apexes at or near the points mentioned. They were patrolled with trawlers and a sprinkling of destroyers, and when any area was threatened by submarine activity the routes in it were changed.

In March 1917, the system was slightly modified. Half a dozen different routes were specified in each approach triangle, and it was proposed to switch the traffic from one route to the other every five days. As the routes in each triangle could lie some 150 m. apart in long. 15° W., there was considerable scope for dispersion, and the system was in effect a system of protection by means of dispersion and routing. The patrols were a mere pretence, for the routes were on an average some 340 m. long, and to patrol them in strength with two destroyers and 16 trawlers was impracticable. The scheme was in its essence an endeavour to circumvent the submarine by routing and it failed. Its advocates could not possibly maintain that it was as efficient as an escort system, for all important ships were actually escorted, and it must be regarded merely as an attempt to burke the significance of the fact that was beginning to assert itself, that every ship had to be escorted.

The idea of general convoy met with strong opposition from every side—at the Admiralty, in the Grand Fleet and amongst the masters and owners of ships. The Admiralty saw that it would involve the creation of a new organization; the Grand Fleet saw its destroyers being taken away; very few recognized the fact that the battleships were now becoming merely complementary factors in a *guerre de course*. The policy of the fleet being ready at any moment to rush out and join battle still held sway. It was a policy resting chiefly on the basis of intelligence supplied by wireless directionals, which made it possible to know when the German fleet was at sea. It meant that the fleet had to be ready at any moment to put to sea in battle array, and in these circumstances the commander-in-chief clung tenaciously to every one of his destroyers. These may be called the strategic objections to convoy, but other strong arguments could be urged against it. Ships would incur delay in assembling, instead of sailing direct; fast ships would incur further delay by having

to reduce their speed to that of the convoy. Convoy meant congestion of ports on departure and arrival, and congestion of labour due to the simultaneous arrival of a number of ships. These objections were as old as the days of Duguay Trouin and Jean Bart, but there were other objections of a more modern type. The masters would never be able to keep station, and were at first much in favour of independent sailings.

On the other hand strong arguments could be marshalled in favour of convoy. Why string out 15 armed trawlers 10 m. apart to supply feeble protection on a line 150 m. long, when four destroyers attached to a convoy could give it continual and efficient protection over double the distance? It might appear at first that a convoy gave the submarine a massed target, but the danger of approaching it was greater, and submarine commanders preferred to attack unescorted ships. The real obstacle in the way of a convoy system was the difficulty of finding the destroyers required for the escort. More than half the modern destroyers were absorbed by the Grand Fleet and the Harwich flotillas. In Feb. 1917 10 were detached from the Grand Fleet to Devonport to assist in escorting important ships, and the use of armed trawlers was extended, but the latter were too slow and too ill-armed to be of much value.

The weekly returns issued by the trade division at this time, conveyed a misleading idea of the situation. They gave the number of arrivals and departure of all nationalities, with the number of British ships of over 1,600 tons lost. The first set of figures had little to do with the real issue, for a small Dutch coaster making three voyages a week to France would figure six times in the arrivals and departures, which ran into several thousands, whereas the number of big ships arriving and leaving daily was very much less. The situation was much worse than it appeared, and the idea of general convoy gained ground.

In April 1917 the British had 3,534 ships over 1,600 tons, of which 1,125 were required for naval and military purposes, leaving only 2,409 available for civil purposes. There were not more than 15 patrols in each area of approach, and in March and April 1917 the number of ships passing through them was about 300, of which 24 were sunk, at which rate, giving each ship a round voyage of two months, practically one-half would have been sunk by the end of the year. Again those who argued in favour of the patrolled route system were arguing in direct opposition to their own policy, for escorts were always provided for all valuable munition ships and ships of national importance, carrying Government cargo (some three or four a day in 1917). The patrolled route system was thereby acknowledged to be an inferior sort of makeshift for ships that were not of national importance. But in April 1917 it began to be seen that every ship was of national importance, and that a loss of 373 ships a month meant that the navy would lose the war before the army could win it. The great advantage of the patrolled route system was that it gave much less trouble and required very few ships, but the same virtues were inherent in no system at all.

One other argument was marshalled against the system, namely, that it would be better to use destroyers directly against submarines. The reply was that no likelier spot could be chosen for seeking them than in the vicinity of a convoy, and from the date convoys commenced to run in May 1917 to the end of the war some 25% of submarines sunk were actually sunk in the vicinity of or when attacking convoys. The losses of April brought the question to an acute stage. The centralization of the control of shipping in the Ministry of Shipping facilitated the inauguration of a general system of convoy. On April 26 the director of the anti-submarine division urged its introduction, and on May 17, 1917 a convoy committee was appointed to arrange the details of a specific scheme. The volume of trade in the Atlantic daily at that time amounted to about 400 vessels, of which 300 were British and 87 neutral. As the area of convoy only extended to about long. 20° W., only some 30 vessels had to be convoyed daily, and it was decided to start with a convoy from the United States and Canada every three days, from Gibraltar every four and from Dakar every five days. The initiation of the system fell largely to Comm. Reginald G.

Henderson, R.N., and its organization and business management to Paymaster-Capt. H. W. Manisty. The first homeward-bound Atlantic convoy started on May 24, and by June 1917 convoys were being regularly run.

The system may be considered under two heads: (1) the organization at the ports of assembly and at the Admiralty, (2) the system of command at sea and the tactical measures of the convoy and escort. At the ports of assembly, escorts had to be provided to conduct ships from the ports of loading and to the ports of discharge. The convoy had to be assembled, the masters mustered and given their instructions, and the convoy handed over to the commodore. This work was done by port convoy officers, who were appointed at home to Lamlash, Devonport, Falmouth and Milford Haven and abroad to Sydney (N.S.), New York, Halifax, Gibraltar and Dakar. At all ports of any size, there were shipping intelligence officers who were now merged in the system and issued route instructions to the masters. At the British Admiralty the two principal tasks were assembly and routing. The general management of the system lay with the organizing manager of convoys (Paymaster-Capt. H. W. Manisty), who worked in close coordination with the shipping controller. In the task of routing he was assisted by naval officers and by a large convoy chart which showed continuously the latest movements of submarines and convoys. This chart was of the greatest value, for it made it possible to alter at once the course of a convoy if a submarine was reported in its vicinity, a system much more elastic and more exact than altering the routes blindly every five days. The three principal ports of assembly were Lamlash or Buncrana (Lough Swilly) in the N., Queenstown, Milford Haven and Falmouth in the S. Escorts were provided by the admirals commanding these areas, and orders for convoy were passed to them. An escort generally consisted of six to eight destroyers for a convoy of about 25 ships. A large portion of the work at Queenstown was gradually taken over by the U.S. navy, who worked in the closest harmony with Vice-Adml. Sir Lewis Bailey, the local commander-in-chief. The whole question hinged on the provision of destroyers. In Feb. 1917 there were only 14 destroyers at Devonport and 12 sloops at Queenstown available for convoy, and it was estimated that 81 destroyers or sloops would be required to provide escort for homeward-bound convoys, and 44 additional destroyers or sloops for outward-bound convoys. It was here that the aftermath of Jutland was severely felt. For the Grand Fleet still had to be prepared to meet the German fleet again, and insisted on a minimum margin of destroyers to enable it to do so.

The destroyer position in 1917 is shown in the table (A = modern new destroyers and flotilla leaders; B = old destroyers).

small staff of signalmen. He took general charge of the convoy until it met the escort, when the commodore then took his instructions from the senior officer of the escorts. A considerable equipment had to be provided for each convoy, including fog buoys, masthead angle tables, station-keeping instruments, and signalling lanterns. A convoy usually consisted of 25 to 32 ships. They were organized in five or six columns with ships 500 yd. and columns 800 yd. apart. The proportion at a later date was eight destroyers to a convoy of 22 ships and six to a convoy of less than 16.

The convoy came across by itself and was met by the escort on approaching the submarine zone, some 300 m. out at sea, and brought in by it. In daylight or in suspected areas or on a submarine report the whole convoy zigzagged, an operation which consisted in an alteration of one or two points (11° to 22°) on each side of the navigator's course (course of advance) for some 10 minutes. These alterations of course were intended to make it more difficult for the enemy to estimate the exact course of the ship, a necessary factor in adjusting the sights for firing a torpedo. Another protective element was the system of camouflage ships, which rendered it more difficult to distinguish the fore and aft line of a vessel, a necessary preliminary in estimating its course (see CAMOUFLAGE: Naval).

The first convoys in May 1917 were all homeward-bound to Great Britain, but by Aug. outward-bound convoys were running too. The main designation of convoys was into H. and O. (homeward and outward), with subsidiary letters indicating the port of departure and a series number for each convoy.

The principal convoys were as follows:—

Homeward (H.)		Outward (O.)	
H.H.	Hampton Roads	O.B.	Buncrana
H.N.	New York	O.M.	Milford Haven
H.B.	" to Brest	O.Q.	Queenstown
H.X.	" to Liverpool	O.F.	Falmouth
H.S.	Sydney (N.S.) and Halifax	O.D.	Devonport
H.E.	Port Said (Eastern)	O.L.	Liverpool
H.G.	Gibraltar		
H.J.D.	Rio de Janeiro, Dakar		

By the end of Oct. 1917, 99 homeward convoys had come in comprising 1,502 steamers with a loss of 10 vessels sunk in convoy and 14 after dispersion, giving a total loss of 24 or 1.57 per cent. By the end of Nov., 77 outward convoys had gone out, with a loss of 0.57 per cent.

The time lost by fast ships remained a distinct disadvantage of the convoy system. In a voyage of 3,200 m. the time lost in waiting at ports of assembly (24 hours) and through slow travelling (133 hours) amounted to 157 hours or six and a half

Destroyer State, 1917.

	Grand Fleet						Convoys				
	Grand Fleet	Scapa	Harwich	Dover	Nore	Portsmouth	Devonport	Queenstown	Buncrana	(Scandin.) Humber	Medit.
Jan. 1917											
Destroyers A	107	—	47	21	—	13	14	—	—	9	29
B	—	15	—	11	9	16	6	—	—	—	8
June 1917											
A	105	—	26	33	—	15	38	31	4	5	29
B	—	11	—	10	7	16	5	—	—	29	8
Nov. 1917											
A	112	—	28	32	—	9	37	35	29	4	32
B	—	11	—	10	12	8	4	—	—	30	8

Summary:—

Grand Fleet and Harwich	172	142	151
Dover, Nore, Portsmouth	70	81	71
Convoys	29	113	139

It was not sufficiently appreciated that the adoption by the Germans of the strategy of the *guerre de course* would mean their abandonment of fleet operations on a large scale, and that the protection of Allied merchant shipping was now just as important as the defeat of the enemy's fleet. The command of the convoy at sea was vested in a "commodore of convoys," usually a captain or commander R.N. or R.N.R., who hoisted his broad pennant in the largest ship of the convoy and was attended by a

days, for a steamer of 5,000 tons. This was eventually diminished by the institution of fast and slow convoys, but on the other hand there were certain advantages which tended to compensate for the delay. Ships did not have to call anywhere for orders, and they were not affected by suspension of traffic, which often held up independent sailings.

The introduction of the convoy system had the effect of forcing the German submarines to attack nearer the shore. It

the early months of the year the crosses indicating ships sunk had been scattered all over the seas W. and S.W. of Ireland. They were now confined to coastal areas, which greatly facilitated the work of rescue and salvage. From Sept. to Dec. 1917, only six ships were lost over 50 m. from land, which meant a great reduction in casualties, with corresponding increase of confidence in convoyed ships. The homeward-bound convoys were also given what were called ocean escorts of armoured cruisers or armed merchantmen, who accompanied them the whole way. By Sept. 1917, Atlantic convoys were in regular operation with about 150 vessels coming in and the same number going out weekly. The destroyers which took the outward-bound convoy out, met the homeward-bound convoy and brought it in, though this procedure often led to delays and difficulties in bad weather, darkness and fog. The bulk of the Atlantic work in European waters was done by British craft, Great Britain providing 70% of the destroyers for convoy and the United States 27 per cent.

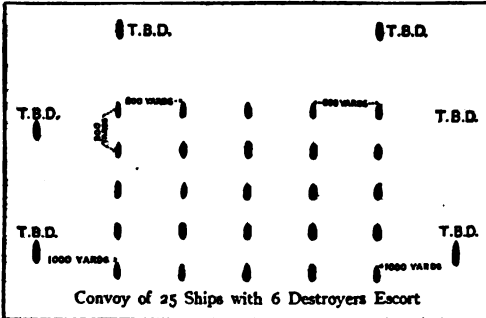

On the E. coast of Great Britain, matters followed a rather different course. A conference had been held at Longhope (Scapa Flow, Orkneys) on April 4 1917, under the vice adm. of the Orkneys and Shetland (Sir Frederick Brock), and it had been decided to convoy Scandinavian ships, on whom Great Britain was dependent for much of its imported wood pulp. They came up from Hull to Lerwick, where an escort of two destroyers and four to six trawlers took them across. This route was much more exposed to attack by surface craft than the Atlantic route, for it was only some 350 m. from Horns Reef, a distance which could easily be covered by a fast cruiser in 15 hours of darkness. Such attacks were the natural counterstroke to a convoy system, and it was one of the principal functions of the fleet to screen convoys from them. The first attack of this sort took place on Oct. 17 1917, when the "Brummer" and "Bremse," two fast German cruisers, originally designed as minelayers for the Russian navy, attacked a Scandinavian convoy of 12 ships, and sank the two destroyer escorts, the "Mary Rose" and "Strongbow," and all but three of the convoy. A considerable force of light cruisers (comprising some 16 vessels) was in the vicinity, but as it was not close to the convoy, and the wireless installation of the escorts was destroyed by the first salvo, the enemy got away.

This was a severe blow to the E. coast convoy system and as a remedy it was proposed to provide a stronger covering force from the Grand Fleet. This entailed the reduction of convoys to three a week, the use of the Tyne instead of Humber as an assembly port, and the provision of nine modern destroyers. The commander-in-chief of the Grand Fleet demurred at the provision of destroyers, and at a conference on Dec. 10 1917 it was decided to use Methil, a small port on the Fifeshire coast of the Firth of Forth, as an assembly port. The decision had hardly been reached when two days later, on Dec. 12, the convoys were again attacked. The German attack was made on this occasion by two half torpedo flotillas (five boats each). The third half flotilla went N., and meeting heavy weather made Udsire on the Norwegian coast at 7 A.M. on the 13th. Steaming

down the coast, the flotilla sighted at 12:30 P.M. a convoy of six steamers from Lerwick to Norway, escorted by the destroyers "Pellew" and "Partridge," and four armed trawlers. The "Partridge" received a shot in her main steam pipe, and after hitting a German destroyer, V100, with a torpedo which did not explode, was sunk. The "Pellew" escaped. The convoy was sunk, and the half flotilla returned home round the Skaw. Two armoured cruisers, the "Shannon" and "Minotaur," were acting as a covering force, but were again too far off, and though they hurried to the spot on receipt of a wireless message arrived too late. Here can be seen a distinct divergence of opinion and method between the conduct of the Atlantic and Scandinavian convoys. An escort against surface craft should be at least within sight of a convoy, and a covering force against an attack in force is of little use if it is not within reinforcing distance. At the root of the insufficient protection accorded to the Scandinavian convoys was the policy prevailing both at Whitehall and at sea that the Grand Fleet must be ready at any moment to sail for the Bight and bring the enemy to action. This naturally led to convoy work being regarded as an entirely subsidiary task. In April 1918, the German admiral Scheer made a bold sortie in force against the convoy. The whole fleet put to sea on April 23 for the Norwegian coast. In front was Adml. von Hipper with the battle cruisers of the first scouting division, and Scheer followed with the battlefleet. The time was ill-chosen. One convoy of 34 ships was just entering the Forth and another of 47 ships leaving it, while the British 2nd Battle Cruiser Squadron and 7th Light Cruiser Squadron were at sea covering them. This was not the only misfortune for the Germans. The "Moltke" at 8 A.M., about 40 m. S.W. of Stavanger, met with a serious accident and had to be towed home, being torpedoed by E42 on her way back. This was the last sortie of the German fleet, and it is interesting to note that it was directed against the convoy system. It led on the British side to the convoy route being shifted to the northward, so as to remove it farther from the source of attack and increase the chance of striking a counter-blow.

The possibility of an attack by surface raiders in the Atlantic had not been lost sight of. The commander-in-chief of the Grand Fleet was kept informed of the approximate position of convoys so as to be in a position to appreciate the situation at once if a raider got out. In Dec. 1917 the two armoured cruisers H.M.S. "Leviathan" and "King Alfred" were attached to convoys, and in 1918 a U.S. pre-dreadnought battleship was added. The possibility of an attack by battle cruisers was met by a U.S. dreadnought force being stationed at Bere Haven in Sept. 1918 to be available to meet convoys coming in, and in Oct. 1918 it actually put to sea for this purpose. Convoy was gradually extended to other routes, and by the end of the war the grand total of ships convoyed reached 88,000, with a loss of 436 ships or approximately 0.5 per cent.

The Mediterranean had always been a difficult area, and the institution of convoys in that sea followed a somewhat different course. Operations in that sea were greatly influenced by the fact that the Mediterranean outside the Adriatic was under French naval control, and the French commander-in-chief, Vice-Adml. Gauchet, would have assumed command in the event of the Austrian fleet breaking out. However, with the consent of the French and Italian naval authorities, a British commander-in-chief, Vice-Adml. Sir Somerset Gough-Calthorpe, was appointed in Aug. 1917 with the special charge of arrangements for the protection of trade and anti-submarine operations. The divided control, and the different patrol areas under different nationalities, did not make for efficiency, but the general arrangements were settled by a conference of Allied officers at Malta (*Commission de Malte*), with delegates from France, Italy and Japan. In the Mediterranean, as at home, the question hinged on destroyers. The Italians preferred to retain their destroyer forces in the Adriatic and on their own coastal routes, just as the British commander-in-chief wanted to retain them with the Grand Fleet. Of the British destroyers available (about 36), some eight were required to watch the Dardanelles

and the Aegean, and operations on the Syrian coast engaged the services of a few more. The Japanese co-operated heartily; their 14 destroyers did yeoman service, and during 1918 the system was entirely dependent on them for the escort of troop transports. The general allocation of British escorting craft in that area in Oct. 1917 was as follows:—

	Destroyers	Sloops	Armed Trawlers	Yachts	Gunboat
Aegean	8	6	6	—	—
Malta	6	11	35	1	1
Egypt	—	11	28	1	—
Gibraltar	2	5	—	3	—

It will be seen that sloops played an important part in the convoy system in the Mediterranean, and as they could not make the voyage from Gibraltar to Port Said without refuelling, it was necessary to provide complete reliefs for the escorts of O.E. and H.E. convoys as they passed Malta. This involved a severe strain on the convoy system, though it was eased later by the addition of some patrol gunboats.

The control of the escorts was at first under a British admiral of patrols, with patrol commanders acting for him at the various ports; who arranged for the formation of convoys and issued route instructions and sailing orders. The principal convoys were the Bizerta-Alexandria (British), Bizerta to Malta (British), Marseilles to Bizerta (French), Marseilles to Algiers (French), Milo (Aegean) to Alexandria (Br. and Fr.), with fast through convoys between the United Kingdom and Port Said under British escort. The system of patrols was retained by the French for a time on the Algerian coast, and the losses there were heavy. The defects which had existed at British home ports exhibited themselves abroad. The staff work was defective; intelligence was not freely and quickly distributed, and action was not taken on it. This led on March 20 1918 to a convoy running right into an area N. of Alexandria where warning had been given of the presence of a submarine waiting for it, with the result that four ships of the convoy were lost.

The Mediterranean remained one of the worst areas for losses. For instance, in Nov. 1917 out of 41 British ships lost, 14 had gone down in the Channel and 11 in the Mediterranean. The losses in the Channel had been stopped by the Dover barrage and Rear-Adml. Roger Keyes; and the First Lord (Sir Eric Geddes) and the Director of Naval Intelligence now proceeded in person to the Mediterranean to consult with the commander-in-chief there and make arrangements for a complete reorganization of his staff. The admiral of patrols was abolished, and a director of shipping movements instituted. Wireless directional stations were established at suitable points, and the losses were reduced to a reasonable figure. In Nov. 1917, 381 sailed in convoy in the Mediterranean, with a loss of nine or 2.35 per cent. In Sept. 1918, 979 ships sailed in convoy with a loss of eight or 0.82 per cent.

Troop movements were one of the most important branches of the convoy system, and it is interesting in this connexion to note the total numbers moved by sea during the war, which amounted to 22,114,000 from Aug. 9 1914 to Sept. 28 1918, made up as follows:—

*Troops moved by sea, Aug. 1914 to Oct. 1918.*

Cross Channel to France	15,576,107
From U.K. to Medit., India, Persian Gulf, Russia	938,562
From North America	1,334,173
From Australia	891,043
In Mediterranean, less 560,000 included above	1,363,976
Between India and Egypt	1,500,204
Various	1,010,691
	22,114,759

In the English Channel most of the work in 1917 was being done by small fast packet-boats, of which there were 16 on the Southampton-Havre route and eight on the Folkestone to Boulogne. During 1915 the average daily number of transports from Southampton was three to four, and the daily average requiring escorts was five to six in 1918. Of loaded troop and

ambulance transports only two were sunk, the "Donegal" on April 17 1917, from Southampton to Havre, with 600 troops and 38 casualties, and the ambulance transport "Wanida" on Aug. 3 1918, from Havre to Southampton, with 125 casualties. The Folkestone to Boulogne route was controlled by the vice-admiral at Dover. Here the principal danger was mines. Vessels crossed only in daylight, and from two hours after to three hours before high-water. The average daily number of transports in the latter part of 1917 and 1918 was some half-dozen in each direction. In the last five months of the war the average daily troop traffic in the Channel was 11,254, viz. 5,300 at Southampton, 3,700 at Folkestone and 2,500 at Dover. The number of troops moved by fast steam-packet vessels in the Channel was enormous, and cannot have been much less than 12 millions, with casualties of less than 1,000. At Dover in the latter part of 1917 three to four destroyers and three to four P. boats were usually employed in cross-Channel escort work.

On the Atlantic route fast troop convoys came into use in April 1918, and during 1918 (up to Nov.) 1,037,000 men came over in them. Three large transports, the "Olympic" (23 knots), "Mauretania" (25 knots), and "Aquitania" (24 knots), also worked singly and independently, with escorts of three or four destroyers to bring them in and take them out. The "Olympic" was attacked on several occasions, but never successfully, and in May 1918 it rammed and sank a submarine (U103). Only three transports were lost on the Atlantic route, the "Tuscania" with 2,400 U.S. troops, torpedoed and sunk seven m. N. of Rathlin Is. on May 2 1918 with a loss of 211 troops, the armed merchant steamer "Moldavia," escorting HCr and carrying troops, torpedoed and sunk in the English Channel on May 23 1918 with a loss of 64 troops, and the "Ottanto," escort to HX50, wrecked on the coast of Islay after collision on Oct. 6 1918, with a loss of 364 troops. The total loss of troops was 537. The losses in the Mediterranean were much heavier, and three-fourths of the troopships sunk went down there though only 20% of troop movements took place in that sea. Submarines worked there under specially favourable circumstances, while the narrow waters gave little opportunity of altering the routes to any great extent. In 1915 some 330,000 troops were conveyed in 242 transports, all of which arrived safely except three—the "Royal Edward," torpedoed and sunk on 13/8/15 in the Aegean with a loss of 865 troops, the "Ramazan" in the Aegean on 19/9/15 with a loss of 11 troops, the "Marquette" approaching Salonika on 23/10/15 with a loss of 188 troops. In 1916, 220,000 troops were conveyed in 143 transports, all of which arrived safely.

During 1917 and 1918 the troop movements were principally to Salonika, Egypt and Syria, and 14 transports were lost as follows:—

*Losses.*

1917: "Ivernia," Marseilles to Egypt, 1/1/17, off C. Matapan	120
"Georgian," Alex. to Salonika, 8/3/17, off C. Sidero	53
"Cameronian," Marseilles to Basra, 15/4/17, 150 m. E. of Malta	223
"Arcadian," Sal. to Egypt, 15/4/17, off Milo	279
"Transylvanian," Mars. to Egypt, 4/5/17, Gulf of Genoa	434
"Cameronian," (French service), 2/6/17, off Alexandria	63
"Aragon," Mars. to Egypt, 30/12/17, off Alexandria	426
"Osmanieh," Taranto to Alex., 31/12/17, off Alexandria	225
1918: "Kingstonian," Alex. to Mars., 11/4/18	9
"Omrah," 12/5/18, off C. Spartivento	1
"Leasowe Castle," 26/5/18, 104 m. from Alexandria	99
"Missic," 29/5/18, 80 m. from Alexandria	44
"Hyperia," 28/7/18, 84 m. from Port Said	52
"Anhui," 12/8/18, off Cyprus	4

There was thus a total loss in the Mediterranean of 17 transports and some 3,036 troops. It will be seen that the total loss of transports was about 20, with a loss of some 4,563 troops, of about one in 3,000, of which 60% occurred in the Mediterranean.

The number of vessels which sailed in British convoy from July 1917 to Oct. 1918 were:—

Outward		7,239
Homeward:		5,529
North Atlantic		1,705
Gibraltar		564
Dakar		495
Sierra Leone		307
Rio de Janeiro		321
Medit., through		10,464
Medit., local		50,487
Scandinavia		12,541
E. Coast		37,562
French coal trade		902
Dutch		

88,026  
(A. C. D.)

**CONWAY, SIR WILLIAM MARTIN** (1856- ), English traveller and man of letters (see 7.69), was elected Coalition Unionist M.P. for the minor (grouped) English universities in 1918. In 1917 he was made director-general of the projected Imperial War Museum, to the organization of which he devoted his energies, with the result of a large exhibition of the collections towards it being opened at the Crystal Palace in 1920. Amongst his later publications were *The Sport of Collecting* (1914), *The Crowd in Peace and War* (1915) and *Mountain Memories* (1920).

**COOK, SIR EDWARD TYAS** (1857-1919), English journalist and man of letters, was born at Brighton May 12 1857 and educated at Winchester and New College, Oxford. Whilst at Oxford he was president of the Union and of the Palmerston club and, on coming to London as secretary for the extension of university teaching, he became a contributor to the *Pall Mall Gazette*, then under the editorship of John Morley. He was later assistant editor under W. T. Stead and editor from 1890 till 1892, when the paper passed into the hands of Mr. W. W. (afterwards Lord) Astor and changed its politics. Cook then resigned, but a year later became first editor of the newly founded liberal evening paper, the *Westminster Gazette*. In 1896 he gave this up to take the editorship of the *Daily News*, which he held till 1901. During the World War, conjointly with Sir Frank Swettenham, he directed the official Press Bureau. He was knighted in 1912, and created K.B.E. in 1913 on the inauguration of the Order of the British Empire. He was a lover of art and of gardening. He published *Studies in Ruskin* (1891), edited the works of Ruskin (1903-7), and wrote the authoritative *Life of Ruskin* (1912), also producing handbooks to the National Gallery and the Tate Gallery, and to the Greek and Roman antiquities in the British Museum. His book on *The Rights and Wrongs of the Transvaal War* ran into several editions, and he wrote *Life of Florence Nightingale* (1913) and *Delano of the Times* (1915), as well as two volumes of *Literary Recollections* (1918 and 1919). He died at South Stoke, Goring, Sept. 30 1919.

**COOK, SIR JOSEPH** (1860- ), Australian politician, was born at Silverdale, Staffs., and at the age of nine started life in a coal-mine. In 1885 he went to Australia and six years later entered the N.S.W. Legislature, holding office as Postmaster-General 1894-8 and Minister of Mines and Agriculture 1898-9. He was elected to the Commonwealth Parliament for Parramatta as a Free Trader in 1901 and became Minister for Defence under Mr. Deakin 1900-10. In 1913 he formed a Liberal Cabinet after the defeat of the Labour party; but just before the outbreak of the World War, the governor-general decided to appeal to the country and as a result of the elections Mr. Fisher assumed the premiership. Cook, before vacating office, had placed the Australian fleet units at the disposal of the British Admiralty. He did not take office again until 1917 when he was Minister for the Navy in Mr. Hughes's second Ministry. The following year he was created G.C.M.G., having in 1914 been sworn of the Privy Council.

**COOLIDGE, CALVIN** (1873- ), American statesman, was born at Plymouth, Vt., July 4 1873. After graduating from Amherst in 1895 he studied law in an office at Northampton, Mass. Here he began to practise in 1897 and soon became prominent in local affairs. After serving as city clerk, city councillor, and

city solicitor successively; he was elected in 1907 a member of the General Court, or House of Representatives, of Mass. He was mayor of Northampton, 1910-11, and sat in the state Senate from 1912 to 1915, being its president during his last year. He became lieutenant-governor of Massachusetts in 1916 and was re-elected in 1917 and 1918. He was elected governor of Massachusetts in 1919 and in 1920 was re-elected under circumstances that attracted nation-wide attention. He had dealt summarily with the striking policemen in Boston Sept. 1919, refusing to re-instate them. In the following gubernatorial campaign this was made an issue by his Democratic opponent, who appealed to those in sympathy with the strikers. The results vindicated the governor's action; he obtained a majority of 114,000 votes (out of a total of 510,000). Already in April 1919, during a strike of telephone operators in Boston, he had proposed that the state take over the lines, but the trouble was soon settled. That he was not opposed to labour was shown by his earlier support of the bill limiting the scope of injunctions against striking employees. In June 1919 he vetoed the bill for increasing the pay of members of the Mass. House, arguing that their service was optional and not a means of livelihood; it was public service and should not be made a job. As governor he recommended that Massachusetts ratify the woman-suffrage amendment to the Federal Constitution. In 1920 he vetoed a bill calling for censorship of moving pictures and likewise a bill to permit the sale of "2.75 per cent" beer. The latter he declared would be "hypocritical legislation," because, with a Federal law on the statute book forbidding beer with an alcoholic content of over one-half of 1%, it would still not be possible to sell 2.75% beer in Massachusetts. At the Republican National Convention in 1920 he received a few votes on all ten ballots for president. When the voting for vice-president began his victory was at once apparent and he was nominated by acclamation. He was elected in Nov. on the ticket with Warren G. Harding by an overwhelming vote.

Some of his speeches were published under the title *Have Faith in Massachusetts* (1919).

**COOPER, SIR RICHARD POWELL, 1ST BART.** (1847-1913), English agriculturist, was born Sept. 21 1847. He became a member of the firm of Cooper & Nephews, chemical manufacturers and exporters of pedigree live stock, and achieved a great reputation as a breeder of shorthorn cattle and Shropshire sheep. He rendered great service to the Argentine Republic by supplying it with British live stock. He died at Berkhamstead July 30 1913, being succeeded as 2nd Bart. by his son Richard (b. 1874), M.P. for Walsall from 1910.

**COÖPERATION** (see 7.82).—The term "coöperation" covered in 1921 a large number of forms of economic organization which had little resemblance except that of name. In considering their development since about 1907, it is necessary to deal with each type separately. Coöperative organizations may be conveniently classified under four main heads:—consumers' coöperation, industrial producers' coöperation, coöperative credit and banking, agricultural coöperation.

*Consumers' Coöperation.*—The British coöperative movement, though it contains producers' societies, is in fact almost synonymous with consumers' coöperation. Of 1,459 societies affiliated to the Coöperative Union in 1919, 1,357 were consumers' societies and 95 producers' societies; the membership of the consumers' societies was 4,131,477 and their trade over £314,000,000, while in the producers' societies the membership was 39,331 and the trade £7,000,000.

The growth of the movement between 1906 and 1920 was very remarkable. The membership of retail societies rose from 2,250,000 to over 4,000,000, their capital from £33,000,000 to nearly £80,000,000, and their sales from £65,000,000 to £198,000,000. The significance of these figures is not merely that this vast industrial system has been built up and managed by the working classes of the United Kingdom, but also that in 1921 between one-third and one-fourth of the population of the United Kingdom consumed commodities manufactured or distributed under this coöperative industrial system, a system which eliminates profit-making and implies democratic control of industry



by the community of consumers. And it was now no longer true to say that the movement flourished mainly in the industrial districts of the North and Midlands; London, for instance, which for long had the reputation of being a "coöperative desert," had become an active centre of coöperation, and the London Coöperative Society, recently formed by an amalgamation of two important societies, was in 1921 the largest coöperative society in the kingdom and had a membership of nearly 200,000 and annual sales of nearly £3,500,000.

But if the expansion of the distributive side of the movement in the local societies had been great, the growth of production and manufacture by consumers' societies was even more remarkable. Nearly all the retail consumers' societies are federated in the English, Scottish, and Irish wholesale societies for the purposes of manufacture and wholesale supply. The value of the goods supplied by these three wholesale societies to their members amounted in 1919 to over £115,000,000. The outstanding feature in the history of 1910-20 was the way in which the wholesale societies, particularly the English C.W.S., proved that the system of consumers' coöperation can be adapted to control the various branches of industrial production. The English C.W.S. is one of the most important and varied industrial businesses in the world. Its employees number about 40,000; in 1919, apart from its activities as a wholesale supplier and distributor, it produced or manufactured for its members commodities valued at over £25,000,000. It was in 1921 the largest flour miller in the United Kingdom and probably the largest timber importer at the Manchester docks. Its factories are to be found in every large industrial centre in England. It produces boots and shoes, textiles and clothing, furniture, metals and hardware, soap and candles, tobacco and groceries.

The most significant feature in the development of the productive activities of the consumers' societies is the way in which circumstances have compelled the C.W.S. to obtain control over the raw materials necessary for the production of the commodities consumed by coöperators. The supply of a staple article like bread will afford a good example of this tendency. The baking of bread has from the earliest times been a successful coöperative industry and large numbers of societies have their own bakeries. Coöperators, however, soon found that baking was only the last link in a whole chain of industries which determined the price and quality of bread. In order that the community of consumers might really exercise control over that price and quality, the movement was driven backwards from the baking industry to enter the milling industry. Though the C.W.S. has become the biggest miller in the kingdom, and the value of the products of the corn-milling industry of the movement was nearly £13,000,000 in 1919, events at the beginning of the World War taught coöperators the weakness of their position unless they also had some control over the production and supply of grain which was ground into flour in their mills. In the early days of the World War the movement stood out against "profiteering" in bread and flour, and there were several instances of societies which succeeded in keeping down the price of bread in their areas by refusing to enter into agreements with the other bakers to raise it. But coöperators had no such power of influencing the price of wheat upon which depended the price of flour, because they depended themselves upon the private wheat-grower for their supplies. These considerations induced the C.W.S. to acquire 10,000 ac. of wheat-growing land in Canada.

There are other equally remarkable examples of the same tendencies. In 1914 the C.W.S. had hardly touched agriculture; in 1921 it owned nearly 35,000 ac. of land in the United Kingdom, and in a single quarter of 1920 it started a cattle market at Gibburn, a butter factory at Carlisle, and a fish-curing depot at Fleetwood. Again, it is only since the war that the English and Scottish wholesale societies have become really large owners of tea estates; during 1920 they purchased no less than 32,000 ac. of tea plantations in India and Ceylon. Lastly, the same process may be observed in the soap and candle industry, for in 1921 the C.W.S. at its depôts in West Africa purchased palm kernels direct from the natives, shipped them to its oil mills in Liverpool, which again supplied to its soap and candle factory at Lirham the materials of another industry.

Coöperative industry, based upon a democratic organization of consumers, spread in the decade 1910-20 from town to town and from industry to industry throughout the economic system of Great Britain, but perhaps one of its most interesting and important developments was in the sphere of international trade. In one sense the coöperative movement, as a large importer of food, raw materials, and manufactured goods, had always en-

gaged in foreign trade, but as an importer there was nothing to distinguish its activities from those of the ordinary private trader or joint-stock company. But the C.W.S. has shown since the war what great possibilities there are in the movement for conducting international exchange of goods on a non-profit-making, coöperative basis. Coöperative international trade implies, of course, that there should be a direct exchange of goods between the organized coöperative movements of the several countries and that profit-making should be eliminated by the payment of dividend upon purchase. The machinery for such trade already exists, for no fewer than 19 European countries possess coöperative wholesale societies, and these wholesale societies can organize international trade with one another on a strictly coöperative basis.

To some extent this kind of trade had existed for many years; before the war, for instance, the English C.W.S. supplied tea to the German wholesale society and imported cheese from the Swiss wholesale society, while the German wholesale, again, supplied goods to the Danish wholesale. But the economic situation at the end of the war gave a great impetus to international coöperative trade. The ordinary machinery of foreign trade had broken down as the result of war and blockade and it would not right itself, partly because of the chaos in credit and the exchanges, and partly because a great deal of the machinery was under governmental control. In such circumstances the coöperative movements of the various countries, resting on the broad basis of the organized consumers both in regard to trade and credit, and with their machinery of production and distribution intact, were not under the same disadvantages as capitalist enterprises.

The English C.W.S. took the lead in organizing international exchange, and it did so in three different ways. It supplied goods direct to the coöperative organizations of France, Holland, Switzerland, Norway, Australia, Canada, Egypt, India, South Africa, Palestine, Brazil, and China. Secondly, it gave credits amounting to nearly £1,000,000 to the Rumanian, Polish, and Belgian coöperative movements, the greater part of these credits being taken in the form of food and manufactured goods. Thirdly, it tried the experiment of direct barter with the coöperators of South Russia, sending a cargo of clothing, etc., to the Russians and receiving in exchange a cargo of raw materials. This experiment in coöperative barter was not very successful, partly owing to political difficulties, but the other enterprises led to international movement among coöperators to develop coöperative foreign trade. In 1919 and 1920 there were conferences of the wholesale societies of the various countries, and a scheme was agreed upon under which each wholesale society would organize an export department, there would be joint purchasing arrangements between the various societies, and there would be a central bureau of statistics for the collection of information regarding goods which each wholesale society either demands or can supply.

Two other developments of the coöperative movement deserve notice. The first is insurance. The Coöperative Insurance Society, which is a joint insurance department of the English and Scottish wholesale societies, now undertakes life, fire, accident, and employers' liability insurance. In all these departments there has been a rapid development in recent years. The most interesting feature is the collective life assurance business, under which a coöperative society collectively insures the lives of all its members: under this system there is a great saving in cost, for there is no collection of premiums from individuals, the premiums being paid in a lump sum by the society and recovered from the dividend payable to members. In 1919 there were 817 societies assured in this way, and the number of members led these societies was 21 millions. This insurance business is conducted on strictly coöperative principles; thus out of the profits on fire insurance, after the usual rate of 5% on capital was paid, a dividend of 2s. in the £ to members and 1s. to non-members upon their fire insurance policies was declared in 1918. The progress of coöperative insurance may be seen in the fact that the income from life, fire, and accident premiums rose from £104,615 in 1909 to £244,066 in 1919, an increase of 783 per cent. The C.W.S. banking activities have made equal progress. The C.W.S. Bank has (1921) two branches, one in London and the other in Manchester. It accepts current accounts from coöperative societies, trade unions and friendly societies, clubs and other mutual organizations. In 1920 the number of current accounts with the bank was as follows: coöperative societies 1,016, trade unions and friendly societies 3,347, clubs, etc., 1,391. The deposits and withdrawals in the half year ending June 1920, amounted to £314,000,000, showing an increase of over 26% on the corresponding period of 1919. The C.W.S. banking is, again, conducted on a strictly non-profit-making, coöperative basis, the profits being returned to customers in the form of a dividend upon their balances.

The facts and figures given above show the tremendous growth of the coöperative movement. The increase in its membership and the great extension in the area of its operations have brought new problems and created new tendencies. Up to the end of the

19th century the movement was content to proceed on its way of steady development in a certain amount of obscurity. This is no longer the case: coöperators have begun to claim the place to which their numbers and operations entitle them in the economic life of their country. These claims can be stated shortly as follows: Consumers' coöperation is a system which ensures a democratic control of industry by the community organized as consumers. Every consumer can join a society and every member has one vote and can, if he cares to do so, exercise an equal power of control over the conduct of industry. The dividend on purchase ensures that commodities are supplied to consumers at cost price and that, therefore, profit is eliminated. Under coöperation production and the various spheres of industry from banking to insurance, from the production of raw materials to the distribution of manufactured articles across the counter of the shop or store, are all carried on for use and not for profit. This system has already shown that it can adapt itself to one economic sphere after another and there is no reason to suppose that the scope and range of coöperative industry are not capable of almost indefinite extension. The movement, with its 4 million members, already represents from 12 to 15 million consumers or more than one-quarter of the population, and consumers' coöperation is now, in fact, an alternative to the ordinary capitalist system of controlling industry.

These claims and ideals are being put forward and are undoubtedly having an effect upon the development of the movement. They are not held consciously by the vast mass of the 4 million members, but they are slowly penetrating the movement, largely owing to the educational work of the societies and the Coöperative Union and also of a very active and influential coöperative organization, the Women's Coöperative Guild, which has a membership of nearly 50,000 women members of coöperative societies.

The increase in coöperative activity and in the consciousness among coöperators of the importance and capacities of their movement are partly the effects of the war. It might have been expected that the dislocation in the economic life of the country and the difficulties of food supply would have had an adverse effect upon a working-class movement like the coöperative movement. The facts show that the reverse was the case. The membership of retail societies, for instance, rose from 3,054,000 in 1914 to 4,131,000 in 1919, an increase of 35%, while the increase from 1909 to 1914 was only 24%. This increased rate of growth was partly due to the rise in prices and the popular irritation against "profiteering," for the elimination of profit-making and the dividend on purchase tend to keep prices down in the coöperative store and make "profiteering" impossible.

Reference has also been made above to the way in which circumstances connected with the war led to an extension of the productive and distributive activities of the C.W.S. But the war had another effect upon British coöperators: rightly or wrongly there grew up in the movement a widespread conviction that it was being victimized in the interests of private traders. Definite complaints were made of unfair treatment of coöperative societies and their staffs by military service tribunals and of discrimination against coöperative organizations in the allocation of Government-controlled supplies. The decision of the British Government to tax coöperative societies by means of the Corporation Profits Tax brought the dissatisfaction of coöperators to a head. The argument was freely used that the movement, in order to protect itself against political action, must "enter politics." In 1917 the whole question was discussed at the Coöperative Congress, and a resolution was passed that the movement should enter politics and nominate candidates in constituencies as an independent unit, but that it might work with other organizations having similar aims and objects. Several coöperative candidates stood in the general election of 1918 and one was elected. The Coöperative party was still in its infancy in 1921 and any estimate of its future was impossible. One feature of the tendency which it represented must, however, be noted. There was a considerable body of feeling in the movement which held that the Coöperative party should unite with

the Labour party and trades union movement to form a "Labour and Coöperative Political Alliance." On the other hand a large number of coöperators were not prepared to accept this proposal. The whole scheme for such an alliance was in 1921 still under discussion in the movement.

Another problem which has assumed great importance in recent years for coöperators is their relations to their employees. In 1919 the consumers' societies employed about 175,000 persons, of whom about four-sevenths were employed in distribution and three-sevenths in production, the wages and salaries paid to these employees amounted to about £20,000,000 a year. The relations between the movement and its employees have been complicated until recent years by a misunderstanding as to the nature of consumers' coöperation. Coöperators themselves did not distinguish clearly between the control of industry by the community organized as consumers for use and not for profit (consumers' coöperation) and the control of industry by the workers or producers in self-governing workshops or factories in which the profits were divided among the workers (producers' coöperation). Hence arose a certain school within the consumers' movement which held that the employees of consumers' societies should share in the "profits," although the dividend on purchase eliminates "profits" in the sense in which a joint stock company or a self-governing workshop makes a profit. The illogicality of this position was, however, gradually realized, and in 1921 very few societies paid the bonus on wages by which the coöperative employee was given a "share in profits."

The coöperative employee was therefore recognized to be merely a wage-earning employee of the democracy of consumers. But the movement, as a large employer of labour, was brought face to face with many new problems. As an employer it stood in a peculiar position. It was composed mainly of the manual wage-earning class, and a very large number of its members were naturally trade unionists. It always professed to pay good wages and to give the best possible conditions of employment. But it was competing with the businesses and factories of the ordinary capitalist type, and competition was so severe that coöperative trade and industry would soon be killed out if wages and conditions of employment within the movement were such as to raise the cost of production substantially above that of its rivals. Most people agree that on the whole the conditions of the coöperative employee compared very favourably with those of employees of private firms and companies, although there were still societies in which wages, etc., were bad. The movement had, however, increasing difficulties with organized labour.

Up to 1920 large numbers of coöperative employees were organized in a special trade union, the Amalgamated Union of Coöperative Employees (membership in 1920, 90,000). This union was founded in 1891, and it throws some light upon its original relations with the coöperative employer that in the original rules there was no provision for strikes. But this happy situation could not and did not continue. The presence of large numbers of trade unionists within the movement means that any demand for increased wages will probably receive some support within a society. There is no doubt that organized labour to some extent took advantage of this fact: a demand for increased wages or shorter hours was often first made upon coöperative societies, with the intention that, when the coöperators had given way, labour could then go to non-coöperative employers and demand that they should pay the same wages or give the same conditions as coöperators.

These facts and conditions gradually led to strained relations between the movement and its organized employees. As a whole the movement stood as strongly for trade union recognition and for the payment of trade union rates of wages as the trade unions themselves, indeed several societies insisted that their employees should be members of their unions. There had also been for long in existence joint machinery of the movement and the unions for settling industrial disputes by conciliation and arbitration; but for various reasons this machinery did not work satisfactorily, and in 1911 the Amalgamated Union of Coöperative Employees began a more militant policy and made provision for a strike

fund. Since that time there have been several strikes against cooperative societies. The whole question of the relation between the cooperative democracy and its employees has been raised by these events, and in 1921 it remained unsettled. It was complicated by the demand among certain sections of labour for workers' control of industry. Many cooperators believed that the workers should be given some share in control, i.e. that they should share with the consumer in the determination of rates of wages and conditions of employment. On the other hand it is obvious that the whole principle of consumers' cooperation, control of industry by the community of consumers for the use of the community, is inconsistent with the complete control either of individual factories and workshops or of whole industries by the organized workers, the principle of producers' cooperation, syndicalism, and guild socialism.

**Foreign Countries.**—The consumers' movements outside England owe their origin directly to the British movement, and all of them were many years behind it in development. But the history of their progress has been almost precisely similar to that of the British movement. In 1921 there was hardly a single European country without consumers' societies. Nearly all of these foreign movements showed a considerable increase in membership and trade during 1910-20; the war, both in belligerent and neutral countries had a marked effect in increasing the number of cooperators and in extending the development and scope of cooperative industry. The following figures show the growth of some of the Continental movements after 1914:—

Country.	Total Membership.		Total Turnover.	
	1914.	1919.	1914.	1919.
Denmark	244,000	377,000	Kr. 203,000,000	Kr. 150,000,000
France	880,000 <sup>a</sup>	1,300,000	Fr. 321,800,000	Fr. 2,000,000,000
Germany	7,214,121	8,288,409	Marks 429,280,519	Marks 1,071,431,966
Norway	31,000	50,000	Kr. 10,019,000	Kr. 71,215,200
Sweden	111,703	225,423	Kr. 30,466,473	Kr. 276,118,000
Switzerland	270,632	353,211	Fr. 141,650,971	Fr. 280,666,378

<sup>a</sup> Estimated.

Though the Continental movements were not so advanced, particularly on the productive side, as the British movement, there is evidence that most of them were firmly established in 1921 and were rapidly following the same path of successful development. The German movement, the largest and most successful on the Continent, had in fact reached the same stage as the British; its membership increased while the number of societies was stationary or decreased; it had a highly developed wholesale society, the *Gross-einkaufsgesellschaft Deutscher Konsumvereine*, whose productive activities included tobacco, soap, matches, textiles and clothing, and confectionery. The majority of the other Continental movements were still in that stage of structural consolidation which in England had been largely completed before 1900. Its most marked feature is federation or amalgamation of small, and often competing societies, so that an increase in the number of cooperators may be accompanied by a decrease in the number of societies. Examples may be found in the recent developments in Denmark and France. In Denmark, although agricultural cooperation had reached a very high state of development, consumers' cooperation in the towns only began about the beginning of this century. Its progress was slow until 1910. Then there was a rapid increase in the number of societies, members, and turnover; this was followed by a period of consolidation, in which there was extensive amalgamation among the Copenhagen societies while the membership and turnover continued to increase. This process, typical of the development of a consumers' movement, can be seen in the following statistics of Danish urban cooperative societies:—

Year.	Number of Societies.	Number of Members.	Turnover Kr.
1910	44	15,710	4,876,000
1914	92	39,698	14,378,000
1919	79	64,187	23,648,000

The same tendency is at work in France, where since 1914 has been seen the establishment of large district societies which absorbed the small local societies.

Another feature of foreign cooperation, which should be noted, is the development of wholesale societies. The development of a consumers' movement into a large industrial system depends upon the growth of a strong wholesale society which shall eventually be capable of undertaking a great variety of productive enterprises. It is significant that in 1919 no less than 19 European movements had wholesale societies. It is true that many of them were still in the stage of wholesale dealing for the supply of the local distributive societies, but the history of the British movement shows that this stage must precede any large development in manufacturing enterprise, and many foreign wholesale societies, e.g. the French, German, and Swiss, have greatly extended their productive activities.

Lastly, it should be remarked that in 1910-20 consumers' cooperation established itself in many countries outside Europe. For instance, up to very recent times consumers' cooperation could hardly be said to have existed in the United States, but latterly, partly owing to the educational work of the Cooperative League of America, a vigorous movement and some 2,000 societies had come into existence. Cooperation had also established itself and was making progress in Armenia, some of the British dominions, e.g. Canada, South Africa, and India.

**Industrial Producers' Cooperation.**—The typical example of producers' cooperation is the workers' society in which the workers own and manage the factory and divide the profits of the enterprise among themselves. But many distinct types of industrial organization are ordinarily included under the term producers' or workers' cooperation, types differing as widely from one another as the ordinary business or joint stock company which gives its employees a share in the profits, and the self-governing workshop. Here we shall deal only with producers' cooperation in the strict sense, i.e. societies or enterprises in which the instruments of production are owned and control exercised by the workers or producers.

There was little change in the position of producers' cooperation during 1910-20. There was no marked extension in the number of enterprises or in the sphere of their operations either in Great Britain or abroad. Thus the number of productive societies in the Cooperative Union actually declined from 108 in 1913 to 95 in 1919, while the number of members rose from 34,662 to 39,331. It is true that their annual sales during the period rose from £3,710,234 to £7,047,147, but the rise in prices would be more than account for this increase. The history of the workers' society from 1907 to 1921 is, in fact, a repetition of its previous history. This form of industrial organization is liable to peculiar difficulties. A small self-governing workshop is easily started and a small workers' cooperative society easily formed. But the problem of internal organization and discipline is extremely difficult, if full democratic control is exercised by the workers. Hence in Britain, France and Italy workers' societies are continually coming into existence, but, with a few exceptions, their lives are short. And, since the larger and more highly organized the enterprise the more acute become the difficulties of organization, control, and discipline, the workers' society, where successful, has practically always remained a small and simple industrial unit. These facts account for the lack of development in producers' cooperation and its failure hitherto to adapt itself to the large-scale, complex organization of modern industry.

It should be noticed, however, that both syndicalism and guild socialism advocate forms of industrial organization which would in effect be developments of producers' cooperation. The workers' society takes the workshop or the factory as the unit of industrial organization and places the control of industry in the hands of the workers organized in factory or workshop; the syndicalist or guild socialist would make each industry, e.g. mining, railway transport or building, the unit of organization and would give control to the workers organized in these larger units. But, although experiments in guild socialism have already been made in England in the building trade, and although the Works Councils Act in Germany and legislation in Italy, following the seizure of factories by the workers in 1920, made some approach to a syndicalist control by workers, both syndicalism and guild socialism still remained in 1921 in the theoretical stage. They had, however, as theories and ideals of industrial organization, taken the place which previously workers' cooperation, in the strict sense, occupied with many people.

**Cooperative Credit and Banking.**—If the consumers' cooperative movements of the world owe their origin to the British movement, Germany can claim to be the pioneer of cooperative credit and banking. Two well-known types of credit societies are distinguished in Germany, the *Schulze-Delitzsch* and the *Raiffeisen*. Apart from their differences in constitution and structure, these two types are characteristic of a difference in function which runs through the whole of cooperative credit in every country. The Schulze-Delitzsch bank supplies credit or loans to the small industrialist in towns; the Raiffeisen bank supplies credit to farmers and agriculturists. This distinction of function is fundamental, and therefore it is not surprising that the history of the spread and development of urban and rural cooperative credit has not followed the same course.

It is obvious that neither large scale capitalist industry nor consumers' cooperation is favourable for the development of urban cooperative banks. The people whom Schulze-Delitzsch desired to help were townsmen, especially the small craftsmen working on their own account, the joiners, shoemakers and so forth; and his ideal was to do this by stimulating their thrift. The idea was to gather together into a society a number of persons, each individually weak economically, but whose combined capital, savings, and deposits would be sufficient to provide the credit upon which the bank might borrow money and lend it to its members. The membership of such an urban bank is always found to consist mainly of small craftsmen, shopkeepers, and small professional men. It follows that this kind of cooperative credit will only establish itself where the small independent hand worker still exists or where the small shopkeeper has an instinct for cooperation. But these conditions are not fulfilled in many European countries. Hence the success of urban cooperative credit has not been nearly so widespread as that of some other forms of cooperation. In Germany itself the movement was a great success during the first 50 years of its existence, but during 1910-21 it had not made much progress. Thus between 1899 and 1905 the number of Schulze-Delitzsch banks rose from 80 with a membership of just under 19,000 to about 1,000 with a membership of about 590,000; in 1921 the number of Schulze-Delitzsch credit societies organized in the general union remained about 1,000 with a membership of 600,000. Outside Germany the urban bank has established itself mainly in Italy, though it also exists on a small scale in France, Belgium and Switzerland. Its greatest success has been in Italy, where Signor Luzzatti was able to adapt the Schulze-Delitzsch model to the requirements of his own countrymen. As in Germany, so in Italy, the statistics of recent years pointed in 1921 to a very considerable slowing down in the growth of the movement. It should also be remarked that there is a tendency for the urban popular banks if they are financially successful, to lose their original object and function, i.e. they tend to neglect the small man for the big man, though there is probably some truth in the contention that this often results from the fact that the bank itself has helped its members to change from small men to big men.

The movement for rural cooperative credit associations has not been subject to the same limitations as the urban movement. In many Continental countries the peasant or small farmer exists in large numbers, and more often than not they are burdened by debt contracted with money lenders on usurious terms. In all these countries the scope for cooperative associations for providing credit to the small agriculturist is very great, and there has in fact been a considerable extension and development of this kind of cooperation. It has usually accompanied a development of other forms of agricultural cooperation, but one of the most curious characteristics of rural cooperative credit is that its development has been most erratic. Thus in Germany the whole of agricultural cooperation has developed from the Raiffeisen rural banks, and the credit associations remain the pivot of the whole movement. But at the other end of the scale are Denmark and Ireland. In no country in the world has agricultural cooperation been more successful than in Denmark, yet in 1921 rural credit societies or banks scarcely existed there. The growth of the Danish agricultural movement was singularly spontaneous, while Irish agricultural cooperation has been the result of intensive and prolonged propaganda. Yet the same fact with regard to cooperative credit is observable in Ireland; in some districts the rural credit societies have performed useful functions, but, taking the country as a whole, they have declined while agricultural cooperation has made great progress; this is shown by the fact that the number of agricultural credit societies declined from 267 in 1908 to 136 in 1920, while the number of agricultural societies and creameries rose from 458 in 1908 to 705 in 1918.

Between Germany at one end of the scale and Denmark and Sweden at the other, the different countries of Europe show great differences in the degree and manner in which they have accepted the rural credit movement. In Italy, Hungary, Finland and France, for instance, rural cooperative credit societies or banks have all proved successful, but as soon as the organization of the movement is investigated in the four countries, marked differences of development become apparent. One of the most important of these differences is the degree in which the movement does or does not rely upon State aid. Thus the Finnish banks are essentially voluntary associations, which rely for their working capital mainly upon the Rural Banks' Central Credit Institute, while this central institute obtains its working capital very largely from Government loans. The Hungarian local credit societies in 1912 numbered 2,900 with a membership of between 600,000 and 700,000, and their capital voluntarily subscribed amounted to about £3,000,000, and deposits to about £8,000,000. For many years they relied in no way upon Government aid, but after the beginning of the century they received loans from a central credit organization financed almost entirely by the State. But it is in France that the reliance of agricultural credit upon the State is most marked. The French rural credit societies are grouped under a district bank to which a society wanting a loan applies; the district bank forwards the application through the Préfet to the Ministry of Agriculture, and the Ministry, if it approves, makes the loan to the district bank. The system is

therefore little more than a system of State aid to agriculture and has scarcely any of the characteristics of voluntary cooperation.

**Agricultural Cooperation.**—Voluntary association among farmers, peasants, or agriculturists can and does take place for many different objects. In addition to the rural cooperative bank or credit society, already dealt with, the chief forms of agricultural cooperative organization may be classified as follows: (1) societies or associations for cooperative supply of the instruments and means of production; (2) societies or associations for cooperative production, e.g. creameries, dairies; (3) societies or associations for cooperative marketing; (4) societies or associations having a variety of miscellaneous cooperative objects, e.g. cooperative insurance. It should be noted, however, that there is no rigid separation of function in the societies actually existing: a single society may and often does perform two distinct functions; it may for instance, as in the case of a dairy, perform both the function of production and that of marketing.

There was a great and widespread development of agricultural cooperation in Europe, and indeed throughout the world, during 1905-20. Unlike consumers' cooperation, however, there was very little uniformity in the development of agricultural cooperation in the various nations. As was pointed out above, in one country the whole of agricultural cooperation will centre in the organization of agricultural cooperative credit, while in another country, like Denmark, a no less highly developed system of agricultural cooperation will exist with little or no organization of cooperative credit. But this lack of uniformity is not confined to agricultural banking; it will be found that in one country agricultural cooperation has developed principally along the lines of cooperative supply, in another of cooperative production, and in another of cooperative marketing. It is not possible, therefore, to give a general account of the progress of agricultural cooperation which would be applicable to every country in which it has proved successful; all that is possible is to show the range of its development and to give one or two typical examples.

In 1907 a fully developed agricultural cooperative system existed already in Germany, Switzerland, Denmark, France, Italy, and Belgium, and a real beginning had been made in Ireland. Up to the outbreak of the World War the old established systems continued to maintain themselves, but such statistics as are available seem to indicate that agricultural cooperation was more adversely affected by the war than the consumers' movements. But the most notable feature of the decade 1910-20 was the spread of agricultural cooperation and its progress in countries where before it was non-existent or only feebly established. The best examples of this development are to be found in the United Kingdom, Norway, Sweden, Finland, and Siberia.

Agricultural cooperation in the United Kingdom nowhere developed spontaneously. Its greatest successes have been obtained in Ireland, where the whole movement was created by the Irish Agricultural Organization Society, founded in 1894. Thanks to the educational work of this organization a considerable number of societies for supply, production, and marketing were formed on the model of Danish societies. The most successful societies were supply societies, dairies or creameries, and egg and poultry societies. By 1908 there were 292 creameries and 166 supply societies. In the next decade there was continuous progress, and by 1920 there were 334 creameries and 371 supply societies. The membership of the creameries rose from 42,404 in 1908 to 50,032 in 1917, and the turnover from £1,700,000 in 1908 to £5,200,000 in 1917, while the membership and turnover of the supply societies rose from 12,999 and £87,000 in 1908 to 31,200 and £601,000 in 1917. These figures indicate the trend of development in Irish agricultural cooperation. It contains two main features. The creameries are productive societies mainly occupied in the cooperative manufacture of dairy products, principally butter and cheese. In the early years of the movement cooperative production was for the most part confined to butter, but the war adversely affected the butter trade, and from 1914 to 1918 there was a big fall in the quantity of butter and a big rise in the quantity of cheese manufactured. The creameries and the Irish Cooperative Agency Society, which is a federation of creameries, also perform the function of cooperative marketing for their members. In recent years the development of the productive side of the movement in the creameries has slackened, and after 1919 conditions in Ireland led to great destruction of property and heavy losses for the creameries. The second feature of Irish cooperation is the rapid development in recent years of the "Agricultural Societies," which are supply societies providing the farmer with every kind of requirement at wholesale prices. They have had

a marked effect upon Irish agriculture, for the supply of such things as fertilizers and feeding stuffs at reasonable prices has created demand for them. The supply associations also perform an important function in providing agricultural machinery which the individual farmer could not possibly afford.

The example and success of the Irish Agricultural Organization Society led to the creation of similar movements and kindred societies in England and Scotland. In 1918 there were in England 237 supply societies with a membership of nearly 40,000 and a turnover of 14,670,000, and 39 dairies with a membership of over 3,000 and a turnover of nearly 1,500,000. In 1918 the total number of all societies in Scotland was 170 and the membership over 8,000.

In Sweden, Norway, and Finland the development of agricultural coöperation has been very rapid. In Sweden organized coöperation dates from 1906 when the "National Union of Swedish Agriculturists" was formed. This union acts both as a supply and a marketing organization. By 1910 the union had 42,000 members and a turnover of over 1,000,000, while there were 19 provincial and 940 local associations for supply and marketing; there were also 477 cooperative dairies. The development in Norway has been as great and even greater, and in 1913 there were 660 cooperative dairies and 1,344 local supply societies. Norwegian agricultural coöperation is remarkable for the highly organized system of federation among both productive and supply societies. Norway and Sweden resemble Denmark in the fact that agricultural coöperation has developed and succeeded with little or no reliance upon cooperative credit. Finnish agricultural coöperation is remarkable for the way in which the various forms of coöperation, credit, supply, production, and marketing have developed. This can be seen from the increase in the turnover of the various types of societies from 1903-13:—

	1903	1913
	£.	£.
Dairies	140,000	1,480,000
Banks	8,000	356,000
Supply	80,000	480,000

The success of agricultural coöperation in Siberia has also been extraordinarily rapid. Cooperative butter-making associations were first started about 1900, and in 1908 the Union of Siberian Creamery Associations was established with 12 affiliated societies for the purpose of both marketing and supply. By 1914 the union had over 1,000 affiliated societies and a turnover of about 1,000,000.

**BIBLIOGRAPHY, GENERAL.**—C. R. Fay, *Coöperation at Home and Abroad* (1920); L. Smith-Gordon and C. O'Brien, *Coöperation in Many Lands* (1919).

**CONSUMERS' COÖPERATION.**—E. Aves, *Coöperative Industry* (1907); G. J. Holyoake, *History of Coöperation* (1875-9, new ed. 1906); *History of the Rochdale Pioneers* (1893, new ed. 1906); *Coöperative Movement of To-day* (1891, new ed. 1896); P. Redfern, *The Story of the C. W. S.* (1913); *The Consumers' Place in Industry* (1920); Catherine Webb, *Industrial Coöperation* (1904); Mrs. Sidney Webb (Beatrice Potter), *Coöperative Movement in Great Britain* (1891, 1893, 1904); Leonard Woolf, *Coöperation and the Future of Industry* (1918, 1919, 1921); *Socialism and Coöperation* (1921). See also the reports and publications of the Coöperative Union and Coöperative Wholesale Society.

**PRODUCERS' COÖPERATION.**—Benjamin Jones, *Coöperative Production* (1894); C. R. Fay, *Copartnership in Industry* (1913); Bernadot, *Le Familistère de Guise* (1892); Dallet-Fabre-Prudhommeaux, *Le Familistère illustré* (1901).

**COÖPERATIVE CREDIT.**—Morman, *The Principles of Rural Credit* (1915); H. W. Wolff, *People's Banks* (4th ed. 1919).

**AGRICULTURAL COÖPERATION.**—G. Radford, *Agricultural Coöperation and Organization* (1917); L. Smith-Gordon, *Coöperation for Farmers* (1918); H. W. Wolff, *Coöperation in Agriculture* (1912). (L. W.')

**COPPER** (see 7 102).—The industrial history of copper after 1910 was more important, both technically and economically, than for many decades previously. A very large part of the world's supply of the metal came after that date from deposits so low in grade that they could not be worked under the conditions of 1905. The major developments in this progress were the enlargement of the scale of operations in individual units of stupendous capacity, immense reductions in the cost of mining by the introduction of the caving system and steam shovelling; reduction in the cost of milling and increase in the extraction of mineral by the introduction of the flotation process; reduction in the cost of smelting by the application of coal-dust firing to reverberatory furnaces and the successful operation of basic-lined converters, and finally the development of processes for the hydrometallurgical treatment of certain ores and the direct production of refined electrolytic copper.

These developments were to a large extent both the inspiration toward the exploitation of the "porphyry" deposits, and the

consequences thereof. The porphyry deposits are more correctly described as fine disseminations of copper minerals through large masses of igneous rock. The economic characteristics of these deposits were mainly their large size and their occurrence at or near the surface in substantially horizontal positions. Fine disseminations of copper had been exploited for many years in the Lake Superior region, but there the copper occurred in its native form and the mineralization was in lodes dipping steeply. Previous to 1905 the occurrence of immense masses of rock, containing about 2% of copper in sulphide form, was known in Bingham Canyon, Utah, at Ely, Nev., and elsewhere, but it was not believed to be possible to exploit them profitably. The conception of profitable exploitation by taking advantage of improved methods in mining and the prosecution of operations on a previously unparalleled scale, was due especially to Daniel C. Jackling (b. 1866) of San Francisco. The provision of plant and equipment for carrying out that conception called for immense ventures of capital (\$10,000,000 for single enterprises), and this at a time when success was problematical. Production by this new group of mines began about 1907, but it was not until about 1910 that it assumed large proportions and the success of the new enterprises began to be clearly recognized. The idea at that time was to work sulphide ores containing about 2% of copper, but in the short space of the 10 years following it became possible to work ores containing but little more than 1% of copper. The brilliant success of the porphyry copper mines and their ability to produce the metal at a very low figure stimulated the operators of lode mines, most notably the Anaconda Copper Mining Co., at Butte, Mont., toward improvements in methods in order to permit them to meet the competition of the porphyries.

**Mining Processes.**—The following are the major advances made during 1910-20 in the arts of mining and metallurgy:

**Steam Shovelling.**—No detailed description is necessary, for the steam shovels and general methods are substantially the same as are used in any excavation work. In their application to the mining of copper-bearing ore, the latter is broken down in benches, a line of holes being churn-drilled back of the face, charged heavily with an explosive, and the ore blasted down in quantities of many thousands of tons. The steam shovel is moved along a track at the bottom of the bench and picks up the broken ore, transferring it to cars alongside. Excessively large boulders are broken up by block-bolting and blasting, but the steam shovel can pick up very large pieces, its dipper being as much as 8 cub. yd. in capacity. The largest steam shovels weigh 325 tons and dig 300 cub. yd. (place measure) per hour. This method of mining is so cheap per ton of ore that it can be applied economically even when it is necessary to shovel away 100 or 200 ft. of worthless overburden in order to uncover 100 vertical ft. of ore. The process of removing the overburden, technically known as stripping, necessarily precedes the actual mining. The laying out of plans for the working of a mine in this way and the figuring of the various factors furnish complicated engineering problems.

**Caving.**—When the overburden is too thick, or is too thick with relation to the thickness of the ore deposit, mining by the caving system is adopted. In essence this system consists in opening permanent galleries under the ore body. Raises to the ore body are then made, and sub-galleries of relatively small size are driven into it, with the purpose of so undercutting the ore body that its support by rock pillars is reduced to the minimum. Finally the pillars are blasted out, causing the superincumbent ore to settle in a great crushed mass. The crushed ore is then drawn off through chutes, previously prepared, into cars in the main galleries. This operation proceeds through the ore body section by section, the natural surface over the mines settling as the ore is drawn off. There are many modifications of this system of mining, but its application to large flat-lying ore deposits is substantially as described. Modifications of the caving system of mining are also applicable in many lode mines, when the lodes are of large size. It is a very economical system of mining owing to its reduced requirements for labour, explosives, timber, etc.

**The Flotation Process.**—Copper ore as mined at the present time contains generally only a small percentage of copper mineral, which is obtained by crushing the ore to such fineness as to liberate the mineral particles and by separating these from the worthless gangue by mechanical processes, commonly performed by washing, in which advantage is taken of the difference in specific gravities. Although there had been great improvements in the processes of ore dressing, the losses of valuable mineral continued relatively high up to 10 years ago. In the flotation process advantage was taken of the discovery that when ore suspended in water was mixed with a small

quantity of certain oils or other agents (the addition of oil being perhaps only 2 lb. per ton of ore) and was then subjected to violent agitation, the copper minerals (if sulphides) would rise to the surface in the form of a froth, while the worthless gangue would settle to the bottom. Separation in this way was possible at relatively low cost and yielded a far higher percentage of the mineral than the older processes. The improvement might be generalized by indicating an extraction of 90%, compared with 65 to 75% previously.

**Metallurgy.**—Previous to 1910 the blast furnace and the reverberatory furnace were frequently competitive choices for the smelting of copper ore. At one time one would be in the lead and then improvements would cause preference to be given to the other. With the increasing fineness of the ore to be smelted, the leaning began to be definitely in favour of the reverberatory furnace, but with the advent of the Dwight-Lloyd sinterer, which enables fine ores to be agglomerated cheaply and efficiently, the blast furnace gained a new prestige. With the successful application of coal-dust firing, however, which was due especially to the work of David H. Browne at Copper Cliff, Ont., the reverberatory furnace obtained an unquestionable predominance, which it is likely to hold. The modern copper-smelting plant designed for the treatment of fine ore comprises roasting furnaces of the MacDugall type and reverberatory smelting furnaces of very large size. Previous to the introduction of coal-dust firing, a furnace at Anaconda, Mont., 19 x 112 ft., smelted 240 tons of charge with one ton of coal per 4½ tons of charge. By the new method a furnace 25 x 144 ft. smelted 650 tons, and one ton of coal smelted seven tons of charge. For the smelting of coarse ore, and especially of heavy sulphide, the blast furnace operated on the pyritic or the semi-pyritic principle still held its place in 1920. These furnaces also were constructed of very large size. The Anaconda Co. attained dimensions of 72 x 1,044 in. at the tuyeres, but this was exceptional, the blast furnaces at most American works being something like 72 x 280 inches.

The converting of copper matte in a basic-lined vessel, which had long been a hope of copper metallurgists, was carried to success by W. H. Pierce and E. A. Cappelen-Smith at the works of the Baltimore Copper Smelting and Rolling Co., just previous to 1910, and early in 1910 the process was introduced in the works of the Garfield Smelting Co. in Utah. Subsequently it was found that the process was not limited to the Pierce-Smith horizontal converters, but could be applied to other forms of converters, both horizontal and upright. The main advantages of the basic over the acid converter are the decreased cost of lining (one basic lining for 2,500 tons of copper compared with one acid lining for 10 tons), greater air efficiency, ability to convert low-grade matte with a mixture of silicious ore, reduction of intermediate products, neatness and cleanliness of plant, and decrease in danger from accidents. The basic converters are lined with magnesite. Their use became general. The reduced cost of converting copper matte to less than 50% of what it used to be with the converters lined with acid (silicious) material.

The existence of immense ore deposits of the porphyry type, but with the copper occurring as oxide or chloride, which rendered the ore unamenable to mechanical concentration, directed renewed attention to the hydrometallurgical extraction of the copper of such ore. At Chuquibambata, Chile, lies the world's greatest known deposit of copper, its development being estimated at about 700,000,000 tons assaying about 2% copper. Exploitation of this was undertaken by the Chile Copper Co., an American corporation. The copper occurs in the ore as brochantite contaminated with chlorides. E. A. Cappelen-Smith devised a process for the leaching of this ore with sulphuric acid, purification of the solution and deposition of the copper by electrolysis, using magnetite anodes, but in practice anodes of ferro-silicon have been substituted. The copper cathodes are melted and cast into bars of grade equivalent to standard

electrolytically refined copper. Production in 1920 was at the rate of 100,000,000 lb. per annum. At Ajo, Ariz., the New Cornelia Copper Co. also produced electrolytic copper directly from ore, from which the copper was first leached by sulphuric acid. Hydrometallurgical extraction of copper was also applied on a large scale for the treatment of tailings, e.g., by the Anaconda Copper Mining Co., and by the Calumet & Hecla Mining Co., the latter extracting the native copper by means of ammonia, and precipitating the copper as oxide by distillation, with recovery of the ammonia. A similar process was employed for ore treatment at the Kennecott mine, in Alaska.

**General Economic Conditions.**—A large part of the world's copper production was in 1920 derived from immense units. Thus in 1918 Anaconda produced 273,000,000 lb. of copper. This, however, was derived from a group of mines. The Utah Copper Co. produced 12,500,000 tons of ore in 1917, yielding 196,000,000 lb. of copper from a single mine. Previous to the World War about 15 cents per lb. was regarded as a market price reasonably to be expected on the average. The cost of production to the largest producers was about 10 cents per lb. The immense demand for copper for military purposes that began in 1915 temporarily outran the ability of the producers to meet it, and the price ran up to about 32 cents per lb. at the end of 1916; but the increased production began to show its effect in 1917 and the market declined materially during that year. In the latter part of 1917 the American Government fixed the price at 23½ cents. Mining, smelting and refining capacities were rapidly increased and in 1917 American electrolytic refiners attained a capacity for the production of 2,800,000,000 lb. of copper per annum. With the termination of the war it was found that all of the Allied and Associated Powers had overbought their requirements, and producers were unable to curtail their scale of operations quickly. This led to the greatest accumulation of unsold copper in the history of the metal, and combined with the greatly increased cost of operation, a bad economic situation developed in the industry which continued into 1921. At the end of 1920 the price for copper was about 12½ cents per lb. Statistics of the world's production of copper are given in the accompanying table.

Previous to the World War the world's production of copper had risen to an annual rate of about 1,000,000 metric tons. In 1916-8 there was an annual production of about 1,400,000 tons. In 1919 it was curtailed to slightly less than the pre-war rate. In April 1921 a general closing of copper mines became necessary on account of the economic situation, and the world's production was thus curtailed to about one-third of the pre-war rate. American interests control (1921) the major part of the copper production of Chile and Peru, and in fact control upward of 80% of the world's production. Outside of this control the production of Japan, Spain, Portugal, Australia and Africa is the most important, but of those countries Japan is the only one whose output has exceeded 100,000 tons per annum.

The best record of progress in the mining and metallurgy of copper, economic conditions, etc., is to be found in the file of the *Engineering and Mining Journal*, New York. Important technical

WORLD'S PRODUCTION OF COPPER  
In metric tons

Country.	1911	1912	1913	1914	1915	1916	1917	1918	1919	1920
United States . . . . .	491,600	563,300	557,400	525,529	646,212	881,237	872,065	879,026	548,677	576,450
Mexico . . . . .	61,900	73,700	52,800	36,337	30,969	55,128	47,503	75,259	60,491	50,480
Canada . . . . .	25,300	35,300	34,900	34,027	47,202	47,985	50,626	52,693	36,106	35,500
Cuba . . . . .	3,800	4,400	3,400	6,251	8,836	7,816	10,313	12,337	9,974	6,485
Bolivia . . . . .	2,600	3,700	3,700	3,874	5,868	5,150	6,400	6,000	7,000	9,900
Chile . . . . .	36,420	41,647	42,263	44,665	52,341	71,288	102,527	96,565	63,930	94,531
Peru . . . . .	27,735	26,969	27,776	27,090	34,727	43,078	45,176	44,414	39,470	31,276
Austria-Hungary . . . . .	2,600	4,000	4,100	3,500	3,500	3,500	3,500	2,500	1,600	1,000
Germany . . . . .	22,400	25,600	25,300	25,000	25,539	24,796	28,632	15,101	15,775	17,255
Norway . . . . .	1,565	2,130	2,741	2,859	2,826	1,614	1,810	2,856	1,800	1,400
Russia . . . . .	25,700	33,500	33,900	31,938	26,881	20,887	16,000	..	..	..
Spain and Portugal . . . . .	51,800	59,900	54,700	37,099	46,200	42,000	42,000	41,000	40,000	25,000
Sweden . . . . .	3,221	3,957	4,215	4,692	4,561	3,181	4,423	2,956	3,558	3,500
Serbia . . . . .	7,000	7,400	8,400	4,443	3,200	5,000	11,200	6,000	1,200	2,436
Japan . . . . .	53,402	62,423	66,500	70,463	75,416	100,635	108,038	90,323	81,805	65,554
Australasia . . . . .	45,979	45,343	45,647	38,667	37,709	39,855	36,564	44,722	16,441	26,486
Africa . . . . .	12,300	16,600	22,900	27,033	31,300	39,815	42,656	31,664	31,500	32,230
Other countries . . . . .	6,300	5,300	3,800	5,000	5,000	5,000	5,000	5,000	5,000	5,000
<b>.. Totals</b> . . . . .	<b>886,622</b>	<b>1,016,169</b>	<b>992,442</b>	<b>928,467</b>	<b>1,087,287</b>	<b>1,397,965</b>	<b>1,434,433</b>	<b>1,408,056</b>	<b>663,646</b>	<b>984,683</b>



treatises are H. O. Hofman, *Metallurgy of Copper* (1914); J. R. Finlay, *Cost of Mining* (1920); Robert Marsh, Jr., *Steam Shovel Mining* (1920); Herbert A. McGraw, *The Flotation Process* (1918); E. D. Peters, *Practice of Copper Smelting* (1911); and D. M. Levy, *Modern Copper Smelting* (1912). (W. R. L.)

**CORDONNIER, VICTOR LOUIS ÉMILIEN** (1858— ), French general, was born at Sury (Nièvre) March 23 1858, and after passing through the military college of St. Cyr entered the infantry as sub-lieutenant in 1879. Eight years later he graduated from the École de Guerre, and thereafter staff and regimental service (including tours of duty in the Alps and in Algeria) alternated till in 1905 he was appointed an instructor at the École de Guerre. He had already served as commander of the cadet battalion and director of studies at St. Cyr, and from this time till 1910 his work was wholly instructional. In this period he wrote his work *Les Japonais en Mandchourie* (published 1911), a study which soon took rank as the most important critical work on the Russo-Japanese War and was translated into several languages (English translation, *The Japanese in Manchuria*, Part I. 1912, Part II. 1914). In 1910 on promotion to colonel he took command of an infantry regiment and in 1913 he was promoted general of brigade and appointed to command the new 87th Brigade, forming part of the reinforced *couverture* created by the Three Years' Service Act.

In command of this brigade, Cordonnier played a distinguished part in the successful action of Mangiennes on Aug. 10 1914, and in the heavy fighting of the IV. Army in the Ardennes. Before the battle of the Marne he had been advanced to the command of the 3rd Division, and he led this formation in that battle and in the advance to Ste. Menchould and the Argonne which followed. On Sept. 15 he was severely wounded, and though he resumed his command in October, he had again to be invalided. In December, having meantime become general of division and an officer of the Legion of Honour, he commanded his division in the bitter trench-warfare fighting in the Argonne, and in Jan. 1915 he was in charge of a group of divisions in Alsace. From May 1915 he commanded the VIII. Corps in the St. Mihiel sector. In July 1916, having been meantime awarded the grade of commander in the Legion of Honour, he was appointed to command the French contingent of the Salonika armies grouped under Sarrail, which became the "Armée française d'Orient."

In general charge of the Allied left wing in Sarrail's autumn offensive he fought the actions of Ostrovo, Florina, Armenohor and Kenali, but owing to acute differences with Sarrail, which are discussed elsewhere, he returned to France just before the battle at Monastir which his movements and combats had prepared. He was already gravely ill, and immediately on landing in France was sent into hospital, where he underwent an operation for cancer. A command on the French front had been promised to him but he was never fit to take it up, and soon after the end of the World War he was placed on the retired list. He then devoted himself to historical and critical work on the war. In 1921 he published an account of the operations of the 87th Brigade under the title *Une Brigade au feu; Polins de Guerre*.

**CORNELL UNIVERSITY** (see 7.166).—The total enrolment of regular students in 1920 was 5,765 (including 1,217 women), divided as follows: graduate school, 407; college of arts and sciences, 1,812; college of law, 178; medical college, 312 in New York city and 37 taking freshman work in the Ithaca division of the college; New York state veterinary college, 103; New York state college of agriculture, 1,283; college of architecture, 130; college of civil engineering, 403; Sibley College of mechanical engineering, 1,210; duplicate enrolment, 110. In addition 2,171 students were enrolled in the 1919 summer session (especially for teachers) and 306 in the short winter course in agriculture in 1920. The students came from nearly all the states, territories, and insular possessions of the United States and from 38 foreign countries—e.g. there were 50 students from China, 30 from Europe, 25 from South America, 16 from Cuba, 7 from South Africa, 6 from Japan, 3 from Australia; etc.

In 1919-20 new endowment was pledged to the amount of \$5,700,000 to increase teachers' salaries. The same year an anonymous gift was received of \$1,500,000 to build and equip a new laboratory of chemistry; \$500,000 from August Heckscher of New York for the endowment of research, and from other sources special gifts aggregating \$708,000. Under the will of Goldwin Smith, \$683,000 was received in 1911 for the promotion of liberal studies, and from Jacob H. Schiff, in 1912, \$700,000 for the promotion of studies in German culture; in 1918 at Mr. Schiff's request the purpose was changed to the promotion of studies in human civilization, and in the same year Baron Charnwood gave 15 lectures on this foundation.

During the decade 1911-20 the university's physical growth continued, the state added 10 large buildings to the equipment of the two state colleges and built a new armory for the department of military science; gifts of \$350,000 from George F. Baker, a New York banker, and \$300,000 from Mrs. Russell Sage provided four residential halls for students; Mrs. Florence Rand Lang of Montclair, New Jersey, added Rand Hall (machine-shop and electrical laboratory) to Sibley College. In 1919 the university's invested funds amounted to \$14,976,500, yielding in the fiscal year 1919-20 an income of \$738,100; the income from state and nation was \$1,397,800, and from tuition fees \$975,000. The grounds, buildings, and equipment were valued at about \$7,637,400. The area of the campus was 359 ac. and that of the experimental farms (adjoining the campus) was about 1,100 acres. The appropriation made by the state to the College of Agriculture for the fiscal year 1920 was \$1,800,588; in 1910 it was \$412,000. The regular annual tuition fee in 1917 was \$200, but in medicine it was \$300; tuition in the two state colleges was free to residents of New York state. The university library in 1920 contained about 630,000 volumes. Among the important recent accessions were the Charles W. Watson collection of works relating to China and the Chinese, 9,309 volumes, presented in 1918; the James Verner Scaife collection of books relating to the American Civil War; and the engineering library of the late Emil Kuichling, 2,003 volumes, presented by Mrs. Kuichling in 1919. The Willard Fiske bequests have been described in three important bibliographies: *Catalogue of the Icelandic Collection* (1914), *Catalogue of Runic Literature* (1918), both compiled by H. Hermannsson, and *Catalogue of the Petrarch Collection* (1916), compiled by Mary Fowler. The results of the Cornell expedition to Asia Minor and the Assyro-Babylonian Orient were published in 1911. In 1920 appeared the fifth volume of the *Cornell Studies in English*, founded in 1916. Several volumes have also been added to the *Cornell Studies in Classical Philology*, the *Cornell Studies in History and Political Science*, and the *Cornell Studies in Philosophy*. The valuable law library numbered about 53,200 volumes. The law school publishes *The Cornell Law Quarterly* (established 1915). Since 1909 the governor of New York state has appointed five members of the university's board of 40 trustees; 15 are co-opted, and the alumni elect ten; others are *ex-officio* members. Since 1916 the faculty has sent three representatives to the board who sit as trustees, but without a vote. Andrew Dickson White (*q.v.*), who, at the request of Ezra Cornell, drew up the original plans for organizing the university and served as its first president, died at Ithaca Nov. 4 1918. Pres. Jacob Gould Schurman (*q.v.*) resigned in June 1920, and Prof. A. W. Smith, dean of Sibley College, was elected acting-president. Of the 21,445 degrees granted since the founding of the university, 18,992, or more than seven-eighths, were granted during President Schurman's 28 years of service. He was appointed U.S. minister to China by President Harding in 1921. Dr. Livingston Farrand (*q.v.*) was elected president in June 1921. Dr. Farrand, formerly a professor in Columbia University, was president of the university of Colorado from 1914 to 1919, and was then appointed chairman of the Central Committee of the American Red Cross. For two years he directed the work against tuberculosis in France under the auspices of the International Health Board of the Rockefeller Foundation.

During the World War the university, in cooperation with the

War Department, conducted at Itasca a school of military aeronautics, a school of aerial photography, a school for military artisans, and a unit of the Students' Army Training Corps, and, at the medical college in New York, a school of radiology for officers of the U.S. Army Medical Corps. Many members of the faculty gave professional or technical service to the Government. About 7,000 students and former students of the university were in uniform; 1,500 of these were in officers' training organizations when hostilities ceased; of the others, 3,300, or 60%, were commissioned officers; 216 died in the service, 147 were decorated for distinguished services or gallantry in action. (W P.)

**CORONEL** (German, *Santa Maria*), the name given to the naval battle fought on Nov. 1 1914 about 40 m. to the W. of Coronel (Chile), between a British cruiser squadron under Rear-Adml. Sir Christopher Cradock and the German East Asiatic Squadron under Adml. Graf von Spee.

The British squadron consisted of the armoured cruisers "Good Hope" (flag, Capt. Philip Franklin: 1902, 14,300 tons, 2 9-2-in., 16 6-in., 21 knots) and "Monmouth" (Capt. Frank Brandt: 1903, 9,800 tons, 14 6-in., 22.3 knots), the light cruiser "Glasgow" (Capt. John Lucas: 1910, 4,800 tons, 2 6-in., 10 4-in., 25 knots), and the armed merchant cruiser "Otranto" (Capt. Herbert M. Edwards: 16 knots, 4 4-7-in.). In the case of the first three ships the full sea-going speed is given. The German squadron consisted of the armoured cruisers "Scharnhorst" (flag) and "Gneisenau" (both 1908, 11,420 tons, 8 8-in., 6 5-9-in., 20 knots) and the light cruisers "Leipzig" (1906, 3,300 tons, 10 4-1-in., 20 knots), "Nürnberg" (1908, 3,596 tons, 10 4-1-in., 22 knots) and "Dresden" (1908, 3,544 tons, 12 4-1-in., 25 knots). The figures, even as they stand, are sufficient to establish a definite German superiority, but they were accentuated by other circumstances. In the heavy weather prevailing at the time the "Good Hope" and "Monmouth" could not fight their main-deck guns, and their broadside discharge (including "Glasgow") was reduced to 2 9-2-in. and 12 6-in. with a weight of 1,060 lb. against the German 12 8-2-in. with a weight of 2,904 pounds. The Germans in addition had the inestimable advantage of having been in commission over two years and being in a state of prime gunnery efficiency, whereas the "Good Hope" and "Monmouth" were both 3rd Fleet ships, which had been lying idle in the dockyards, manned entirely with reserve men on the outbreak of war. The "Canopus" (Capt. Heathcoat Grant), another 3rd Fleet ship (with 4 12-in. and 12 6-in. guns), had been relegated by Rear-Adml. Cradock to purposes of convoy, as she could steam only 12 knots, and was 300 m. to the S. escorting two colliers when the action began. There can be little doubt that neither in guns nor in gunnery was the British squadron capable of meeting the enemy, and long before the fatal day it should have been reinforced by at least two cruisers of the 1st Cruiser Squadron, all of which were ships in long commission with good armament. ("Defence" carried 4 9-2-in., "Warrior," "Black Prince," "Duke of Edinburgh," 6 9-2-in.) This measure had been suggested, and even ordered in the case of the "Defence," but had never reached fulfilment. The "Black Prince" and "Duke of Edinburgh" were doing convoy work in the Red Sea and Indian Ocean, and the "Warrior" was at Port Said, while the "Defence" was with Rear-Adml. Stoddart on the east coast of South America.

Cradock left Valparaiso (Chonos, Chile) with the "Monmouth" on Oct. 30 and proceeded N., leaving the "Canopus" to remedy engine defects and bring on colliers. The "Glasgow" had been sent on to Coronel (Concepcion) to send and receive telegrams, and a rendezvous had been arranged with her 50 m. W. of Coronel for Nov. 1. The junction took place at 1 P.M., and as the sea was too heavy for boats, the mail was floated to the "Good Hope." It had scarcely been opened, and the rear-admiral was probably just reading his telegrams, when at 1:50 P.M. German wireless sounded loud and clear.

Von Spee had come from Mas-a-Puera, the last anchorage in his long Pacific trip. On Oct. 30 he had sighted the lofty ranges

of the Andes, and the "Prinz Eitel Friedrich," an armed merchantman, had been sent into Valparaiso to coal, while the squadron cruised at slow speed out of sight of the port. At 3 A.M. on Nov. 1 she sent news of the "Glasgow's" visit to Coronel on Oct. 31 and the German admiral steered S. to intercept her.

Cradock, when the report of German wireless came in, had made a signal to spread 15 m. on a line of bearing N.E. by E. (in the order from westward—"Good Hope," "Monmouth," "Otranto" and "Glasgow"), course N.W. by N., 10 knots, to get in touch with the enemy. At 4:20 P.M. the line was not yet completely formed when the "Glasgow," to the E., sighted smoke and altered course N. 80 E. to get in touch with it. At 4:40 P.M. she reported the "Scharnhorst" and "Gneisenau" steering between S.E. and S. She turned at once to S. 65 W., closing at full speed on the "Good Hope," and the whole line began to close rapidly on the flagship. The "Canopus" was 300 m. to the S., toiling with her colliers in a heavy sea.

Von Spee had been steering S. at 14 knots. The "Nürnberg" and "Dresden" had been detached to examine passing ships, and the former was 25 m., the latter 12 m. in rear. About

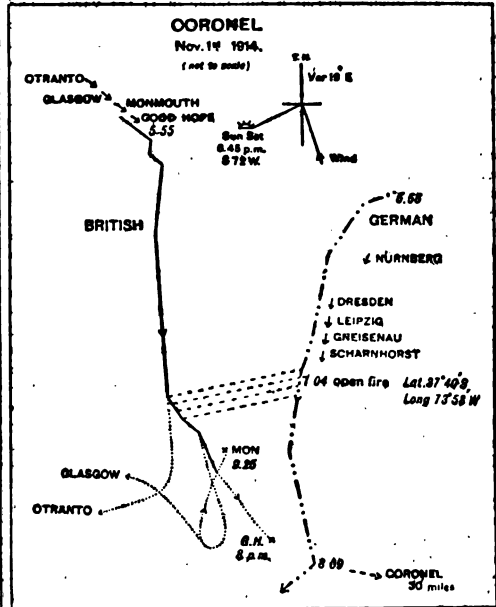

4:15 P.M. von Spee was about 40 m. N. of Arauco Bay when the "Glasgow" was sighted to the W., and he turned and followed, working up to full speed. It had been blowing hard from the S.E. (von Spee says S.), and a heavy sea was running, hurling sheets of spray right over the conning towers; the sun was setting in the south-west. When the "Glasgow" sighted the enemy the "Good Hope" was some 26 m. to W. of her, and turned to the E. to join her squadron, as they came closing in. By 5:50 P.M. the British squadron was in line, with the "Good Hope" leading and the "Monmouth," "Glasgow" and "Otranto" behind, on an easterly course. The enemy were about 11 m. away to the E., steering south-westward (see map). Both squadrons now altered course to the S., and by 6:4 P.M. were steering approximately parallel courses at a range of about 14,765 yards. Cradock then seems to have tried to close in order to force an action while the sun was still high enough to dazzle the enemy, but von Spee turned away and Cradock resumed his southerly course. Had he not been hampered by the

"Otranto," which could only go 16 knots, it is possible that he might have attempted to fall back on the "Canopus," for the rest of his squadron was faster than von Spee's and he could have slipped away to the S. during the night and picked up the "Canopus" next morning. But this would have meant forsaking one of his ships, and Cradock was not the man to take this course. He decided to fight, and sent the "Canopus" a message to this effect at 6:18 P.M. At 6:20 P.M. he turned towards the enemy, but von Spee turned away an equal amount. He was now about two points before Cradock's beam, biding his time and waiting for the sun to set.

The "Otranto" asked if she was to keep out of range, and not getting a clear reply drew out of line on the "Glasgow's" starboard quarter, a potent reminder that a ship that has no guns to fight and no speed to run away is a delusion and a snare. The sun was setting (sunset at 6:45 P.M.), and as soon as it dipped beneath the horizon (just before 7 P.M.), the English ships were silhouetted sharply against the red glow of the western sky, whilst the Germans were scarcely discernible against the gathering night clouds in the east. About 7:4 P.M. von Spee turned one point towards the enemy to clear the smoke, and opened fire at a gun range of 11,373 yards. The conditions were rendered difficult by spray; heavy sea and smoke driving down the line, but the shot fell only 500 yd. short. The third salvo hit the "Good Hope" forward at about 7:9 P.M. and sent up a burst of flame. The rest of the German squadron joined in, the "Scharnhorst" engaging the "Good Hope," the "Gneisenau" the "Monmouth," and the "Leipzig" the "Glasgow." The "Good Hope" had now opened fire, but in the falling light the splashes could not be seen and her firing was poor and ineffective. In the next quarter of an hour the German gunners found the target again and again, and by half-past seven the British cruisers were obviously in distress. The roof of the "Monmouth's" fore 6-in. turret had been blown off and the turret was blazing. She had sheered off to starboard about 7:15 P.M., and the "Glasgow," which continued to follow in the wake of the "Good Hope," had to ease down to avoid masking her fire. A fierce fire had broken out amidships in the "Good Hope" and was increasing in brilliance. It was almost dark. Though the moon had risen about 6:30 P.M. it was still low, but the glare of the fires kindled in the British cruisers offered a sufficient target. At 7:45 P.M. the "Good Hope" was losing speed; the range had closed to about 5,000 yards. About 7:51 P.M. two shells struck her between the mainmast and after funnel, and a vast column of smoke and fire rose into the air. When it subsided the ship was still afloat, but she was nothing but a gutted hull lighted by a dying glare, and she fired no more. Thirty-five hits had been counted on her by the "Scharnhorst's" gunners. By 8 P.M. the fire had died down, quenched by the sea. The "Monmouth" had ceased fire and turned away to the W., followed by the "Glasgow," who had been heavily engaged by the "Leipzig" and "Dresden" and had received five hits. The rising moon shone fitfully through the clouds, and the "Glasgow" continued to fire at any ship that showed up, but as this only betrayed her position she ceased fire at 8:5 P.M. The "Monmouth," badly down by the bows and listing to port, turned N. at 8:15 P.M. to get stern to sea. But von Spee had now launched his light cruisers to attack and they were hot upon the trail. The "Glasgow" could only leave the stricken field, and she lost sight of the enemy at 8:50 P.M.

It was the "Nürnberg," which had been making frantic efforts to overtake her squadron, that found the unfortunate "Monmouth." She missed her with a torpedo and opened fire at 800 yards. The "Monmouth" was listing so badly that she could not use her port guns. The "Nürnberg" ceased firing for several minutes to allow her to surrender, then gave her a final broadside, and she went down at half-past nine with flag flying. The "Otranto" had fallen out and was now working gradually round to the S. towards Magellan Straits.

The British shooting was poor. The "Scharnhorst" was hit twice with little injury; the "Gneisenau" received three

hits, one of which bent the flap of the after turret, an injury of little moment. This deficiency must be attributed partly to failing light and an inferior horizon but also to the fact that the ships had had scant opportunity for training and their fire-control equipment was poor. The squadron was weak in guns and gunnery. When the German squadron was sighted it would have been possible to fall back on the "Canopus," but this would have entailed the destruction of the "Otranto," which would have been overtaken by the enemy in two or three hours. Cradock preferred to fight and take the chance of inflicting injury on the German squadron, which was far from any base of retirement and repair. He fought a brave fight, checked von Spee in his onward career, and he and his men take their place in the great roll of naval heroes. His foe was a worthy antagonist. When the Germans at Valparaiso acclaimed him a naval hero, he shook his head. The wide spaces of the Pacific lay behind him, he had fought a famous battle, but the southern waters of the world lay before him, behind loomed the Atlantic, and he knew that Britain's arm stretched far. He found the sequel of his victory at the Falklands (see FALKLAND ISLANDS BATTLE). (A. C. D.)

**CORSON, MIRAM** (1828-1911), American scholar (see 7:204), died in Ithaca, N. Y., June 15 1911.

**COSTA RICA** (see 7:219).—The internal history of Costa Rica is almost continuously concerned with the transmission of the presidential office. In 1880 the first comparatively free election seated José Joaquín Rodríguez, a clerical Conservative. He ruled practically without assistance from the legislature until he made use of it to seat Rafael Yglesias as his successor. Yglesias was reelected in 1898, but gave over the power in 1901 to Anunciación Esquivel, after which time serious political revolts were infrequent. Fair liberty of the press was enjoyed, and elections were not abnormally corrupt. Cleto González Víquez was chosen president in 1906, and Ricardo Jiménez in 1910, both by popular vote. Alfredo González was named in 1914 by the legislature after the popular vote had failed to indicate a choice. The radical programme of González led to his forced removal by Federico Tinoco, who was elected to the presidency after his coup in 1917. Tinoco's power was minimized by his failure to obtain recognition from the U.S. Government. He was obliged to put down revolts in 1918; in 1919 a popular movement led by Julio Acosta drove him out of the country. Acosta, at first provisional president, was elected and inaugurated in May 1920. Costa Rica prospered under its recent rulers, who promoted public improvements, effected desirable sanitary measures, and promoted education. The landowners, professional men, and habitual politicians controlled the country, their politics being animated by clique and family considerations rather than by genuine differences in policy.

After 1913, the president, members of Congress, and the city officials were popularly elected. The president had large political patronage, dominating Congress. The judiciary was practically independent; its head was the Supreme Court, chosen by Congress. The central Government had more control over local affairs than was usual in Central America. Manhood suffrage was legalized in 1920, and the suffrage was extended to women also. During the World War Costa Rica was among the first of the Hispanic-American countries to evince sympathy with the Allied cause, although the German colony and German influence were strong. On Sept. 21 1917 the Government severed relations with Germany, and on May 23 1918 declared war on Germany. The pact for the Central American Union was signed in Jan. 1921 by Costa Rica, but was later rejected by the National Assembly. For boundary dispute, see PANAMA.

*Finance and Economics.*—During the period 1910-20 Costa Rican coffee was high-priced and a source of national prosperity. There was not, however, a large class of rich native landowners. On the plateau the small peasantry was prosperous and industrious. Foreigners controlled the mines, banks and commerce. The United Fruit Co. settled numbers of English-speaking people along the E. shore in the banana lands. From 1911 to 1918 the coffee crop ranged from 248,000 to 385,000 sacks, valued at from 8,221,000 to 14,789,000 colones (the colon equals \$0.453). In 1920 the coffee export was valued at \$4,744,000. In 1918 the banana exportation

was worth 7,129,553 colones. The exportation of the principal variety, *musa sapientium*, is about 11,000,000 bunches per annum. In 1912 the foreign trade was \$20,043,311. In 1917 the imports were \$5,595,240 and the exports \$11,382,166. In 1917 the national debt was \$20,254,000. The national budget, approved by the President Jan. 7 for the fiscal year 1920, estimated the expenditure at 12,866,553 colones and the revenues at 13,068,000 colones, leaving a probable surplus of 139,447 colones. The estimated pop. in 1919 was 454,995; the area of the republic being about 23,000 sq. miles. (H. I. P.)

**COST OF LIVING.**—Till recent years the phrase "Cost of Living" was only used loosely by economists when the balance between movements of wages and prices was in question, but from 1914 onwards during the World War the need of a measurement of the rise of prices gradually resulted in making the expression prominent in industrial and statistical discussions. In popular parlance it has since become a recognized economic problem. It has frequently been assumed that the term "Cost of Living" (or "High Cost of Living"—sometimes abbreviated to "H. C. L.") has a unique and definite meaning, and that accurate measurements can be applied to it, but in fact the meaning is vague and the statistical methods appropriate to it are complex and lead to results whose precision is not of a high order.

The phrase may be regarded as an abbreviation for "the cost in a defined region to persons typical of a defined social or industrial class of goods of a kind usually purchased at frequent intervals, by the consumption of which a certain standard of economic welfare is reached." We may usefully distinguish four cases: (a) where the standard is a physiological minimum; (b) where some conventional or average budget of expenditure is taken and the cost of the items in it is measured at different times or places; (c) where the items are varied but the whole contents of the budget result in an unchanged standard of welfare; (d) where both the contents of the budget are modified and the standard is raised or lowered. Case (b) is that which has in recent years been the subject of measurement, but case (c) is that which is in reality appropriate to the problem of measuring or adjusting real wages.

Case (a).—Prior to the World War attention was directed by Mr. Seebohm Rowntree (*Poverty, A Study of Town Life*, 2nd ed. 1902) to the cost of obtaining in York (England) and elsewhere food, clothing, heat, light and shelter sufficient for a family to maintain itself in health and efficiency for work, when all possible economy was practised, subject to the availability of commodities and the legal requirements for housing, decency, etc. The minimum of food was computed in relation to the quantity of calories, carbohydrates and protein calculated by Atwater and others as necessary for maintaining health and vigour under various conditions of life, and dietaries were drawn up which contained the necessary constituents at the minimum aggregate cost; to this cost was added the expenditure on clothing, fuel, cleansing materials, etc., and rent, which was found to be customary among persons in regular work at the lowest rates of wages of adult men. The most natural meaning of the cost of living is perhaps the cost of maintaining the minimum standard thus described. The standard is, however, not scientifically definite; apart from questions as to the validity and applicability of the measurement by calories, it is clear that there must be a great difference between the amount of food necessary for work of low and of high efficiency; the Indian, Chinese and Japanese peasants live on a sparser diet and produce a lower output than the English or Americans; definable points are where efficiency is a maximum (which needs a more liberal diet than that considered by Mr. Rowntree) and where the value or additional efficiency exactly equals the cost of the additional food, etc., necessary (for whose ascertainment there are no observations); and Atwater's standard is in fact conventional (see Bowley, *Measurement of Social Phenomena*, chap. viii., 1915). If we drop the word "minimum" and speak of Mr. Rowntree's conventional standard for demarcating poverty, we can properly measure the change in the cost of living at this standard (if the facts are ascertainable). The varying cost of

the official civilian rations, computed in Germany *circa* 1919, gave a measurement similar to that described. The cost of Mr. Rowntree's standard, and one modified in the direction of ordinary purchasers by Bowley, was worked out for certain English towns in 1913 (*Livelihood and Poverty*, 1915). A legal minimum wage could be based on a standard thus defined, but in fact it is generally related to a higher conventional standard.

Case (b).—The usual method of measuring the change of the cost of living during and since the war has been as follows. Detailed statements of expenditure having been obtained from a number of working-class households (in most countries at some date prior to 1914), an average budget is formed showing so many pounds of meat, bread, etc., with the prices and expenditure in considerable detail. The average prices of the same foods are ascertained from time to time, and the expenditure necessary to purchase the former quantities at the new prices is computed. The cost of living (so far as food is concerned) is then taken as having increased or decreased in the same ratio as this standard budget. In many countries a standard of the same kind is established for clothing, fuel, light, rent, cleansing materials and some other articles, and the cost of the aggregate, including food, is computed from time to time. The result obtained (if the process were complete) would be the relative cost of maintaining a defined standard constant in every detail. It is generally expressed as a percentage; thus if the costs were 25s. and 30s. at the two dates, the ratio is 100:120, the index number at the second date is 120 and the percentage increase 20.

This method cannot be carried out in its entirety for two reasons, namely, lack of information and change of quality of the commodities in the market. In most countries data of expenditure and prices are only obtained for principal commodities (meat, bread, etc.) and not for those on which little is spent (currants, pepper, etc.); unless owing to shortage of supplies there is a run on the articles not included, these omissions cannot affect the result significantly. In some countries expenditure is not known, but only prices, and then the resulting calculation is generally valueless; and in others currency is so variable that the computation is meaningless. In nearly all cases there is no sufficient knowledge of expenditure on clothing either in total or in detail, and it is often difficult to obtain adequate data for fuel and light or for miscellaneous items. The sums included in the calculations, in fact, account for only a part of ordinary household expenditure, but where more care has been given to the question the part is a large proportion of the whole. Classes of expenditure that are not strictly necessary, such as amusements, tobacco, alcohol, etc., are generally omitted, as are occasional expenses (doctors, purchase of furniture, etc.), but in some cases subscriptions to trade unions, etc., insurance payments and travelling to work are included. The miscellaneous expenses omitted become a large proportion of total expenditure as we go up the scale of incomes. The difficulty due to the change of quality of goods which has been so marked since 1914 is even more fundamental. Over any long period the actual constituents and quality of a pound of bread, a cut of meat, a pair of boots, change considerably, but from some points of view these gradual changes are not important. During the war, however, substitution of one commodity or ingredient for another was sudden and common, and the pre-war quality was unobtainable at any price, or if obtainable had a quite altered position in domestic economy. Consequently the prices included in the calculations were frequently not for the same things at different dates and the precision of the measurement was greatly diminished. After the Armistice there was some return to former qualities, but the change has been sufficient to undermine the foundation of the numbers, and a new basis is necessary, as discussed in the following sections.

It should be added that separate budgets ought to be formed (and in some countries have been formed) for different grades of income and for different classes of occupation, and also for single persons and for married persons with dependents.

The structure of the index numbers of the cost of living is shown most clearly by algebraic symbols. If  $Q_1, Q_2, Q_3, \dots$  are the number

of units of the commodities in the standard budget, and  $P_1, P_2, P_3, \dots$  the prices per unit at the date taken as starting point, and we write  $Q_1 \times P_1 = E_1, Q_2 \times P_2 = E_2, \dots$  where  $E_1, E_2, E_3, \dots$  are the expenditures on the commodities, then  $E = E_1 + E_2 + \dots = Q_1 P_1 + Q_2 P_2 + \dots$  is the whole expenditure at the first date on the standard budget. Let  $p_1, p_2, p_3, \dots$  be the prices per unit at a subsequent date; then  $Q_1 \times p_1 = e_1, Q_2 \times p_2 = e_2, \dots$  are the presumed expenditures, and  $e = e_1 + e_2 + \dots = Q_1 p_1 + Q_2 p_2 + \dots$  is the whole expenditure. The ratio of the cost of the standard budget at the second

date to that at the first, is  $\frac{e}{E} = \frac{Q_1 p_1 + Q_2 p_2 + \dots}{Q_1 P_1 + Q_2 P_2 + \dots} = \frac{E r_1 + E_2 r_2 + \dots}{E_1 + E_2 + \dots}$

where  $r_1 = p_1/P_1$  (the price ratio for the first-named commodity at the two dates),  $r_2 = p_2/P_2, \dots$ . The last expression shows that by this method the ratio of the costs of living is a weighted average in which the price ratios are weighted by the expenditures at the first date; hence we only need to know these expenditures and ratios, and not the actual quantities nor prices. In the official measurement in the United Kingdom only the quantities  $E$  and  $e$  are in fact used; this method is very convenient in dealing with rent (for which there is no natural unit of quantity) and with clothing (for which a general price ratio is obtained without any definition of unit). The general theory of weighted averages shows that a considerable roughness in the estimation of the smaller expenditures is smoothed out in the process of averaging, but that it is important to obtain precision in the case of large items, such as clothing, treated in a single entry, and rent. It is important, however, that the  $r$ 's should be accurately known when they differ much from one another, and the quality of the commodities that are priced should be the same at both dates.

The index number for the second date is  $\frac{e}{E} \times 100$ , and the percentage increase is  $\left(\frac{e}{E} - 1\right) \times 100$ .

**Case (c).**—It must be granted that when the cost of living is compared at two places or at two dates we ought not to assume that precisely the same quantities of the same commodities are purchasable in both cases, and in order to make a strict numerical comparison we need a test of equality of standard if not a means of comparing two standards. The problem so stated has not yet been completely solved. A measurement could be made on a strictly nutritive basis and the cost of purchasing in the most economic way the amount of calories (including the necessary protein) considered proper to health and efficiency could be ascertained in both countries or at both periods; but this would only give a theoretic solution, since it ignores the influence of custom and taste in diet, and, in fact, in developed countries relatively few people have been compelled to purchase their nutriment in the cheapest possible way. The actual practical question in England in 1921 was what was the cost of maintaining the pre-war standard of living in nutritive power and satisfaction or pleasure derived from food and clothing, allowance being made for changes in prices and available qualities. This statement introduces the vague word *satisfaction*, which it is not practicable to define exactly, though some mathematical methods based on economic principles have been suggested for ascertaining its equality in two cases.

It has been suggested (Bowley, "Measurement of Cost of Living," *Journal of the Royal Statistical Society*, May 1919, p. 354, and "Cost of Living and Wage Determination," *Economic Journal*, March 1920, p. 117) that an approximation could be reached by devising "a diet, based on available supplies, as nutritious, digestible and not less attractive than the pre-war diet, and estimate at what price it could now be obtained," or "to frame a new budget of goods obtainable, and, in fact, purchased, by housekeepers with the same skill of adjusting purchases to desires as in the case of the earlier budgets. Instead of measuring satisfaction by formula, we may recognize that it is subjective and a matter of opinion, and obtain from representative working-class women a budget which in their opinion would now give the same variety and pleasure as a selected budget of 1914, care being taken that the energy value is the same. The result would give a new conventional budget, the ratio of whose cost to (that of) the pre-war budget would give a rough measure of the change of . . . the cost of living." It should be added that this solution would only be definite if the "satisfaction" was obtained as cheaply as possible, it being assumed that before the war given sums of money were laid out to the best advantage. This method would only be satisfactory if, fairly close agreement was obtained as to the equality of the new with the old standard.

Another method has been used in the case of comparison of the cost of living in two places. In 1905 the Labour Department of the Board of Trade (United Kingdom) initiated inquiries about the cost of living in the United Kingdom, United States, France, Belgium

and Germany, and obtained budgets of expenditure in each country; the results are published in the official papers Cd.3864, Cd.5609, Cd.4512, Cd.5065 and Cd.4032. A comparison was made between the cost of living in the United Kingdom and in each other country on a double basis, as follows:—it was found that an English housewife purchasing in 1909 in the United States a week's supply of food as customary in England would have spent 38% more in the first-named country, the ratio of the costs of living being on this basis 100:138; on the other hand, an American housewife purchasing in England a week's supply of food as customary in America would have found her expenses reduced in the ratio 125:100 (Cd.5609, pp. lxxvii, lxxviii). If these ratios had been reciprocal, either would measure the difference in the cost of living (so far as food is concerned); as it is, their divergence illustrates the want of definiteness in the problem. Now it is quite possible to obtain in any country a current budget to be compared with a pre-war budget and the method just described can be applied. Thus, in the *Journal of the Royal Statistical Society*, May 1919, p. 344, details are given of the standard pre-war British budget and of the average of budgets collected by an official committee on the cost of living in the last year of the war, in which the standard of living had been modified and had fallen somewhat. A housewife purchasing in 1918 the same qualities and quantities of food as in 1914 would have increased her expenditure in the ratio 100:212, while if she had purchased in 1914 the same qualities and quantities as in 1918 the ratio of the earlier to the later expenditure would have been 100:202. Both these are possible measurements (the first being identical with case *a* above), and where the difference between them is so moderate an intermediate number, such as the arithmetic or geometric mean (which are nearly coincident), 100:207 makes a plausible measurement of the change.

Another method, allied to that just described, gives perhaps the most practical solution, though its adequacy can hardly be proved from theoretic conditions. Obtain typical budgets of expenditure at two dates; compile a new or mean standard of quantities which item by item are the averages of the entries in the budgets; thus, if in one the consumption of 33 lb. of bread is stated, in the other 35 lb., enter 34 lb. in the mean standard; now find the cost of the mean standard at each date and take the ratio of these costs as the measurement of the change in the cost of living. In the example just used this ratio was found to be 100:204. (On the methods formerly used for this problem, see Palgrave's *Dictionary of Political Economy*, vol. iii., article "Wages, Nominal and Real," p. 640.)

If all prices rose in the same ratio the methods now described would necessarily yield the same result; the need for choice arises from inequalities of increase, including the case where the goods are no longer in the market as one where the price is indefinitely great. Now if at one date purchases are made so as to maximize the satisfaction in the outlay of the week's house-keeping allowance, as we may reasonably assume, and prices rise irregularly, it is evident that somewhat less will be bought of the commodities which have risen most and more of those which have risen least if a maximum is still obtained, and that consequently the increase in the expenditure necessary to obtain the same satisfaction as before is less than the increase if exactly the same quantities had been purchased. For example, if oranges are doubled in price and bananas increased only by one-half, more bananas and fewer oranges will be purchased.

If with the notation used above we also write  $q_1, q_2, q_3, \dots$  for the quantities purchased at the second date, the measurement obtained by using these quantities is  $\frac{Q_1 p_1 + Q_2 p_2 + \dots}{Q_1 P_1 + Q_2 P_2 + \dots} = \frac{1}{100} I_1$  (say) instead of  $\frac{Q_1 p_1 + Q_2 p_2 + \dots}{Q_1 P_1 + Q_2 P_2 + \dots}$  (as above) =  $\frac{1}{100} I_1$  (say). If the

small letters refer to a second place (instead of date), then as between England and America  $I_1 = 138$  in the illustration  $I_2 = 125$ . For two dates the method illustrated from expenditure on food in England gives  $I_1 = 212$  and  $I_2 = 202$  and the suggested index number is  $I_1 = \frac{1}{2}(I_1 + I_2) = 207$ . The other method recommended is to take

$I_2 = \frac{\frac{1}{2}(Q_1 + q_1)p_1 + \frac{1}{2}(Q_2 + q_2)p_2 + \dots}{\frac{1}{2}(Q_1 + q_1)P_1 + \frac{1}{2}(Q_2 + q_2)P_2 + \dots} \times 100$ . It is easily shown

that  $I_2$  is always intermediate between  $I_1$  and  $I_3$ , and by a more troublesome analysis that  $I_2$  is less than  $I_1$  when prices in general are rising and quantities consumed of individual goods have increased or diminished according as their prices have risen more or less than the average as measured by  $I_1$ ; in fact

$$I_1 - I_2 = 100 \frac{(p_1 - rP_1)(Q_1 - q_1) + (p_2 - rP_2)(Q_2 - q_2) + \dots}{(Q_1 + q_1)P_1 + (Q_2 + q_2)P_2 + \dots}$$

where  $100r = I_1$ , and the factors in each term of the numerator are both positive or both negative under the conditions named. Hence,  $I_2$  satisfies many of the fundamental conditions of the measurement required. Bowley (*Stat. Journal*, loc. cit., p. 351) suggests





bitrary. The number of eggs consumed (about 12 per household per week) is based on summer records and is no doubt higher than the average for the year.

The resulting index numbers were as in Table II:—

TABLE II.

Index numbers of retail food prices in United Kingdom. (London only prior to 1914.) Average for year unless otherwise stated.

1903 . . . 92	1909 . . . 96	1914 (Aug. to Dec.) . . . 112
1904 . . . 92	1910 . . . 98	1915 . . . 131
1905 . . . 92	1911 . . . 98	1916 . . . 160
1906 . . . 92	1912 . . . 103	1917 . . . 198
1907 . . . 94	1913 . . . 103	1918 . . . 215
1908 . . . 96	1914	1919 . . . 219
	Jan. to	1920 . . . 296
	July 100	1921 (Jan. to April) . . . 257
		May . . . 232
		June . . . 218

For the monthly figures from Aug. 1914, see the article PRICES.

During the war the validity of these figures was much weakened by the failure of the supplies necessary for the budget to be realized. In 1918 a committee on the cost of living (Cd.6080) collected 1,400 budgets from the urban working-class of a kind comparable with the standard budget already named. Among the differences found were the following (Table III):—

TABLE III.

Weekly Consumption of a Standard Family.

	1914	1918
Bread and flour . . . . . lb.	33.5	34.5
Meat . . . . . lb.	6.8	4.4
Bacon . . . . . lb.	1.2	2.55
Eggs (number) . . . . .	13.0	9.1
Cheese . . . . . lb.	.84	.41
Butter . . . . . lb.	1.7	.79
Margarine . . . . . lb.	.42	.91
Sugar . . . . . lb.	5.9	2.83
Potatoes . . . . . lb.	15.6	20.0

The consumption in 1918 practically exhausted the supply, and the calculation of what the 1914 budget would have cost if the quantities had been available at the prices of 1918 was purely theoretical. The committee found that in fact expenditure on food was 90% higher than in 1914 at a date when the above index number showed an increase of 108%. The committee estimated that the nutritive value (measured in calories) of the 1918 budget was only 3% lower than that of 1914. Similarly a committee on the financial results of the occupation of agricultural land and the cost of living of rural workers (Cmd.76 of 1919) reported (p. 43) that the expenditure on food of agricultural labourers had increased 84% since 1914 at a date when the index numbers showed an increase of 108%, and that the nutritive value had fallen 3% as in the towns. Possible methods of measuring the change of the cost of living under such circumstances have been discussed above; here it is only necessary to say that the official index number is not valid.

After the Armistice supplies tended to return to their pre-war level except in the cases of sugar, eggs, butter and cheese; margarine of an improved quality took the place of butter to a considerable extent. The increase of prices over 1914, however, varied greatly from commodity to commodity; thus in March 1921 British beef and mutton were respectively about 161 and 176%, while imported beef and mutton were only about 109 and 100% above the level of 1914; sugar had risen 310%, butter 145%, eggs 200%, tea only 74% and margarine 67%. With this variation it is certain that an unchanged standard would not be composed of unchanged constituents and that (as argued above) the cost of living had risen less than the index numbers show, unless expensive substitutes had taken the place (e.g. of sugar. There had been no information obtained, however, as to new arrangement of consumption up to the summer of 1921.

(b) Other Commodities.—Next in importance to food comes rent. The figure included in the index number allows for such increases for rates, repairs, etc., as are legally permissible and

is accurate for persons who by remaining in the same house since 1914 have the benefit of the Rents Restriction Acts; the increase for those who have moved must have been very variable and for it no estimate is available.

The cost of clothing, which ranks next to rent in expenditure, is always very difficult to measure owing to the difficulty of defining the garments or stuffs purchased, and of assigning their relative importance in the budget, and also there was great variability in the qualities in the shops during 1914 to 1921. The difficulties can be understood by comparing the estimates and method of the Cost of Living Committee (*loc. cit.*, pp. 21-3) with those of the official index number described in the *Labour Gazette*, April 1921, pp. 178-9; the former found an increase of 96% between July 1914 and the summer of 1918, the latter reaches increases of 210% in June and 240% in Sept. 1918. The differences are partly attributable to the great variability of the increases among the articles in consequence of which the relative importance given to each has great effect, and in this respect the committee's measurement is the more systematic; and partly due to the difficulty of obtaining quotations for the same qualities of goods or in allowing for substitution. The question is too intricate to discuss here; it can only be suggested that the results have little precision, and that the process of obtaining an estimate based on a new budget in which modifications of custom are allowed for is even more necessary than in the case of food.

Fuel and Light present little difficulty when a general average for the country is in question since the retail prices of coal and of gas are ascertainable. The variation from north to south in price and consumption and that between winter and summer is not very important, since where coal is dear, gas is used for cooking, and in working-class households one fire is necessary throughout the year for cooking and this also provides heat.

The official index number allows only one-twelfth of the weekly expenditure for all items not already included, or about 15. 6d. per household in 1914. This sum is exhausted by cleaning materials with a very small margin for tobacco, newspapers, household replacements, and fares. Insurance and trade-union subscriptions are not included, nor is alcohol.

The five classes of expenditure now named are combined in the following proportions, stated for clearness on the basis of a pre-war urban weekly expenditure of 37s. 6d. Food 22s. 6d., rent (including rates) 6s., clothing 4s. 6d., fuel and light 3s., sundries 1s. 6d. Here the proportions on food, rent and light rest on good evidence; that on clothing, for which the expenditure varies greatly according to the income and personnel of the family and for which there has never been a satisfactory investigation, is little more than a guess based on vague estimates; that on sundries is the residuum when other expenses are met and is probably too low.

The results are tabulated in Table IV:—

TABLE IV.

Official Measurement of Cost of Living in the United Kingdom.

Relative importance	Food	Rent	Clothing	Fuel & Light	Sundries	All combined
	60	16	12	8	4	100
July 1914	100	100	100	100	100	100
Dec. 1914	116	•	•	•	•	110 (approx.)
June 1915	132	•	125	•	•	125
Dec. 1915	144	•	135	•	•	135
June 1916	159	•	155	•	•	145
Dec. 1916	184	•	180	•	•	165
June 1917	202	•	200	•	•	180
Dec. 1917	205	•	240	•	•	185
June 1918	208	•	310	•	•	200
Dec. 1918	229	•	350	•	•	220
June 1919	204	105	350	•	•	205
Dec. 1919	234	117	370	185	•	225
June 1920	255	117	325	230	220	250
Dec. 1920	282	142	305	240	230	269
June 1921	278	145	300	255	210	219

The statistics are for the beginning of each month.

\* Not stated separately at these dates.

The numerical importance of the criticisms indicated may be seen by computing the number for Dec. 1920 with the following alterations: suppose that the modification of diet (margarine instead of butter, decrease of sugar and eggs and increase of other foods) reduces the food index to 260, that the increase in clothing cost is half that shown (as indicated by the Cost of Living Committee for 1918) and the index is 200 instead of 305, and that rent accounts for 20% of all expenditure, food for 50% and sundries for 10%, instead of 16, 60 and 4% respectively, then the index number would be 225 instead of 260. This is, perhaps, an extreme hypothesis, but it has been suggested (Bowley, *Prices and Wages in the United Kingdom, 1914-1920*, p. 75) that a standard equivalent on the whole to, but modified in detail from, that of 1914 might have been attained throughout by an increase of expenditure equal to four-fifths of that officially stated (100+4/5 of 169 = 235 in Dec. 1920).

OTHER COUNTRIES

(a) *Cost of Food.*—The experience of other countries has been similar to that of the United Kingdom both in the dates of increase and in the difficulties of satisfactory measurement. Table V contains in summary form the index numbers showing the movement of food prices in all the countries which are known to publish official figures based on 1914 prices. Except in Belgium, where the index numbers are the simple average of prices of selected commodities, the measurement is made on the same method as in the United Kingdom and based on the expenditure found from a collection of working-class budgets, though in some countries the number of such budgets is very small. In some cases, noted in the sequel, some changes in commodities are introduced, and in others alternative measurements based on actual expenditure at different dates are given. These numbers are summarized from time to time in the *Labour Gazette* (London), the *Labour Review* (Washington), in the *International Labour Review* (Geneva), and in the *Monthly Bulletin* of the Supreme Economic Council; they are of course also to be found in the official publications of each country.

Though the movements are by no means uniform, the rise is universal, and, except for a temporary break after the Armistice, continuous in nearly all countries till at least July 1920. The break in the rise occurred at various dates after June 1920, as shown by figures in Table VI.

TABLE VI.  
Index Numbers of Retail Prices of Food.  
(The level of 1914 is taken as 100.)

1920	United States	Canada	United Kingdom	Paris	Rome	Amsterdam	Norway	Sweden	Australia	South Africa
June	215	228	258	369	228	325	204	311	294	187
July	215	227	262	373	235	318	210	319	297	194
Aug.	203	221	267	373	239	322	212	333	308	194
Sept.	199	215	270	407	238	324	217	336	307	197
Oct.	194	214	291	420	247	341	218	339	306	192
Nov.	189	206	282	426	246	361	220	342	303	186
Dec.	175	200	278	424	235	375	208	342	294	188
1921										
Jan.	169	195	263	410	—	367	199	334	283	—
Feb.	155	190	249	382	—	376	199	308	262	—
March	153	178	238	359	—	386	199	300	253	181
April	149	172	232	328	—	412	188	300	247	—
May	142	155	218	—	—	—	—	292	237	—

\*Figures for beginning of following month.

The prices are of course strongly affected by the relative value of the currency in the countries, and some indication of the effect may be seen (Table VII) by converting them to a gold basis by means of the exchange on New York. July 1920 is taken as being near the date of maximum prices. Corresponding figures are also given for Jan. 1921.

TABLE VII.

	July 1920			Jan. 1921
	Food index number	Exchange on New York as percentage of parity	Deducted index number	Deducted index number
London	258	76.6	198*	210
Paris	373	39.4	146	151
Rome	318	27.6	88	71
Amsterdam	210	85.5	180	168
Stockholm	297	79	235	230
Switzerland	335	88*	207	193
Australia	194	77 (approx.)	149	142
United States	215	100	215	169

\*Obtained by converting through London, thus: 258 X 76.6 + 100 = 198.

Thus if an American had come to London with \$198 in July 1920 he could have converted them into as many £ currency as would buy as much food as \$100 would have purchased in July 1914. In Rome he would have needed only \$88.

TABLE V.

Index Numbers of Retail Prices of Food (based on the official statistics of the various countries).  
(In every case the prices used are in the currency of the countries in question.)

	1914	1915	1916	1917	1918	1919		1920		1921
	July	July	July	July	July	Jan.	July	Jan.	July	Jan.
United Kingdom*	100	132	161	204	210	230	217	235	262	263
France (Paris)	100	122	132	183	206	—	261	290	373	410
France (other towns)	100	123	142	184	244	248	293	—	380*	429
Italy (Rome)	100	95	111	137	203	259	206	275	318	367
Italy (Milan)	100	—	—	—	325	309	310	412	445	573
Switzerland*	100	119	141	178	222	—	250	—	232	—
Belgium	100*	—	—	—	—	—	—	396	459	493
Netherlands (Amsterdam)	100*	114	117	146	176	189	204	197	210*	199
Denmark	100	128	146	166	187	186	212	251	253	276
Sweden	100	124	142	181	268	339	310	298	297	283
Norway	100	—	160	214	279	279	289	295	319	334
Spain*	100	107	114	136	162	168	180	193	—	—
United States	100	98	109	143	165	181	186	207	215	169
Canada	100	105	114	157	175	186	186	206	227	195
British India (Calcutta)	100	108	110	116	121	—	155	153	170	—
South Africa	100*	106*	114*	127*	129*	135	139	177	197	172
Australia	100	131	130	126	132	140	147	160	194	181 (March)
New Zealand	100	112	110	127	139	145	144	158	171	174 (Feb.)

\*NOTES.—*United Kingdom.*—The figures relate to the first day of the month following that named.  
*France*, other towns.—The figures include fuel and light; the number 380 relates to June not July 1920.  
*Switzerland.*—The numbers relate to June not July in each year.  
*Belgium.*—The base is April 1914.  
*Netherlands.*—In some accounts 217 is stated for July 1920 instead of 210; the basis in 1914 is the average for the year, not the month of July.  
*Spain.*—The July figures are for the average April to Sept. and the Jan. figures the average Oct. to March each year.  
*South Africa.*—The figures for 1914 to 1918 are the averages for the years, not July only.

It is evident that neither the currency reckoning nor a conversion to a gold basis show the real meaning of the increase of prices; we need also to know the change of income accruing to purchasers, on which some information is given below.

In Germany a calculation of a standard food budget based on official maximum prices in 200 localities was made monthly for the years 1914-9 (*Deutscher Reichsanzeiger*, Dec. 19 1919). Since the foods could not generally be obtained and there was much evasion of regulations the numbers have hardly even academic interest, and the more important information is that given below under cost of living. The numbers in question yield the following figures (Table VIII):—

TABLE VIII.

Index Number for Standard German Budget.

	1914	1915	1916	1917	1918	1919
Jan.	102	118	161	214	225	253
July	100	152	213	270	231	228

In Finland (*Abo Underrättelser*, Feb. 25 1920) it appears that the cost of 1 litre of milk, 5 litres of potatoes and 1 kilo. each of butter, flour, bread, meat, bacon, sugar and coffee rose from 11.68 to 106.23 Finnish marks between 1914 and the beginning of 1920, an increase in the ratio 100:909.

For Japan a correspondent of the London *Economist* (Aug. 9 1910) gave details showing that the expenditure on food of an ordinary family had doubled in Tokyo between the first quarters of 1916 and 1919.

(b) Other Commodities.—The preceding tables relate (with certain exceptions) to food only. In many countries index numbers of the cost of living including other expenditure are published with more or less regularity. The relative importance given to classes of expenditure in pre-war budgets is as shown in Table IX, each expenditure being expressed as a percentage of that allotted to food:—

TABLE IX.

	United Kingdom	United States	Norway	Sweden	Denmark	Holland	Rome	Milan	Canada	New Zealand	Hungary
Food	100	100	100	100	100	100	100	100	100	100	100
Rent	27	35	33	34	35	35	21	18	66	33	77
Fuel & Light	13	14	9	11	11	14	12	7	19	11	11
Clothing	20	43	26	25	28	28	16	19	—	26	56
Other items	7	69 <sup>a</sup>	40 <sup>b</sup>	58 <sup>c</sup>	36	43 <sup>d</sup>	11	16	—	39 <sup>e</sup>	59

a including 13 for furniture; b including 3 for taxes; c including 14 for taxes; d including 2 for taxes; e including 3 for taxes; f fuel and light included in other items.

It is clear that the methods of establishing the original budgets varied greatly from country to country. Since rent has increased little for those who have not moved and clothing has increased greatly in expense a good deal depends on the relative importance allotted to these items.

The various countries have collected information about the cost of living at different dates in rather sporadic ways. Only the United Kingdom has computed a monthly index from the beginning of the war on a uniform system. No doubt the difficulties of measurement and of obtaining data described above have been experienced in all countries and it would require very detailed criticism to ascertain whether the basis of collection was sufficiently wide and whether the prices were typical. The numbers in Table X must only be regarded as approximate both in respect of amount and of date, but they indicate the periods of increase and show in which countries it has been most rapid. In most countries there has been a shortage of houses and a legal restriction on rent; the figures are based in general on rents which have been hindered from rising. Whether the index number of food exhibited in the previous table or that of the cost of living has increased most depends mainly on a balance between rent and the cost of clothing, and the latter must have been uncertain in all countries.

In general the index numbers show a nearly regular increase from 1914 to the end of 1918, stationariness in 1919 and a rapid rise to a maximum at the end of 1920.

Many of the figures have been given from time to time in the *Labour Gazette* (London) and the *Labour Review* (Washington) and in similar publications in other countries. For Table X they have been extracted from the originals in the country to which they relate as far as possible.

TABLE X.

Index Numbers of Working-Class Cost of Living at a Fixed Standard in Various Countries (Food, Rent, Fuel, Clothing, etc.).

	United Kingdom	United States	Canada	Norway	Sweden	Amsterdam	Denmark	Rome	Milan
1914 July	100	100 <sup>a</sup>	100	100	100	100 <sup>f</sup>	100	100	100
Dec.	125	103	—	—	—	—	—	—	—
1915 July	135	104	97	—	—	—	116	—	—
Dec.	—	—	—	—	—	—	—	—	—
1916 First quarter	135	—	—	—	—	—	—	—	—
Second quarter	140	—	—	—	—	—	—	—	—
Third quarter	150	—	102	—	—	—	136	—	—
Fourth quarter	160	118	—	—	139	—	—	—	—
1917 First quarter	165	—	—	185	—	123	—	—	—
Second quarter	175	—	—	—	152	—	—	—	—
Third quarter	180	—	130	—	166	—	—	—	—
Fourth quarter	185	144	—	219	—	132	155	—	—
1918 First quarter	190	—	—	235	192	153	166	—	—
Second quarter	195	—	—	—	203	—	—	—	—
Third quarter	210	—	146	260	219	170	182	—	311
Fourth quarter	220	174	—	264	242	165	—	229	346
1919 First quarter	220	—	—	263	267	171	190	236	352
Second quarter	210	177	—	262	263	181	—	219	369
Third quarter	215	—	156	258	257	179	211	206	290
Fourth quarter	225	199	—	301	257	191	—	238	342
1920 First quarter	230	—	177	288	259	199	242	284	378
Second quarter	240	217	—	295	265	202	—	312	426
Third quarter	255	—	190	331	270	207	262	318	453
Fourth quarter	270	201	181	341	281	—	—	365	513
1921 First quarter	250	—	176	311	271	—	265	379	568
Second quarter	—	—	—	—	249	—	—	—	—

<sup>a</sup>Average for 1913. <sup>f</sup>The original figures for Amsterdam are based on a calculation for 1910-1; it is estimated from other data that prices rose 7% between 1910 and 1914 and the numbers are adjusted on this assumption, but they can only be regarded as approximate when 1914 is compared with other years; for the sequence beginning 1917 the relative numbers are correct.

In some other countries there have been occasional calculations on a similar basis. In Uruguay (*Boletín de la Oficina Nacional del Trabajo*, Montevideo, May-Aug. 1919) the increase in necessary expenditure from 1913 to 1919 is given as 44% for an unmarried and 36 or 37% for a married labourer. In Argentina (*Revista de Economía Argentina*, May 1920) the increases in food, rent and other expenses are stated as 32, 16 and 165% respectively from 1914 to 1918 and as 45, 50 and 150% from 1914 to 1919. For Hungary (*Labour Gazette*, April 1921) a statement is quoted that whole family expenditure was in Jan. 1921 47 times as great in currency as before the war; rent had only increased 67%. For Germany an estimate is given (International Financial Conference, Brussels, 1920, Paper vii, statistics of retail prices) that the index number for food, clothing, rent, fuel, etc., in 28 towns was 373 in April 1919 compared with 100 in Jan. 1914, and if 373 is taken for Frankfurt-on-Main in April 1919 subsequent numbers for that town are: Sept. 1919 432, Nov. 1919 466, Jan. 1920 630 and March 1920 740.

CHANGE OF STANDARD OF EXPENDITURE

In all the tables so far given the index numbers are intended to measure the change in cost of an unchanged and unmodified standard, except that in Denmark there has been a slight change in the relative quantities of butter and other fatty substances. In a few countries, however, the actual change in expenditure (100Zqp + ZQP in the notation described above, instead of 100ZQP + ZQP, the formula for unchanged standard), and in Amsterdam the index number, has also been calculated by using quantities currently bought instead of the original standard (100Zqp + ZQP).

For the United Kingdom the Cost of Living Committee of 1918 (Cd.8980) compared the expenditure of a standard artisan family in 1914 and the summer of 1918, and found the increase to be 74% to June 1918 and 80% to Sept. 1918, when the increase on the standard budget was 100 and 110%; the difference was partly due to the methods of treating clothing; for food alone in June 1918 the increase in expenditure was 90% and in the cost of the standard budget 108%. The Ministry of Food also made a computation of the change in the cost of the average quantities of some principal foods consumed in the United Kingdom from time to time, yielding the comparison shown in Table XI.—

TABLE XI.

	Expenditure on Principal Foods*	Index Number for Standard Budget
July 1914 . . . . .	100	100
Feb. 1918 . . . . .	144	208
June 1918 . . . . .	181†	208
Sept. 1918 . . . . .	197	216
March 1919 . . . . .	181	220
Jan. 1920 . . . . .	215	236

The figures in this column are those stated in the *Zobyr Gazette* for two months later, but it is known that the computation was in arrears of the facts, at least at the earlier dates.

†190 if all the foods of the standard budget were included.

The differences point to important modifications of diet under rationing and control of prices; the Cost of Living Committee found that the nutritive value had fallen very little.

In Switzerland an estimate was made by Dr. Jenny (*Journal de Statistique et Revue économique suisse*, 1918 fascicule 1, pp. 76 seq.) of what he calls the "nominal" and the "effective" increase of cost. The nominal increase, viz. that of an unchanged standard of food, was 92% between 1912 and March 1917; the effective increase, viz. the increase of expenditure when allowance was made for the known or estimated diminution in the consumption of bread, meat and the increase in that of potatoes, was only 36.5%.

In Milan the cost of the food actually consumed has been estimated from time to time, and added to the cost of housing, fuel, clothing, etc., these being taken as an unchanged standard after July 1918. Some of the results are shown in Table XII.

TABLE XII.

Index Numbers Based on:

	Actual Expenditure	Cost of pre-war Standard
1914 Jan. to June . . . . .	100	100
1918 Jan. . . . .	162	—
July . . . . .	205	286
Dec. . . . .	259	321
1919 July . . . . .	265	250
Dec. . . . .	287	352
1920 July . . . . .	376	441
Dec. . . . .	441	534

In Holland (Amsterdam) a more elaborate method is used, for not only has the expenditure been ascertained at frequent intervals (unfortunately of only a very small number of families) but it has been computed (see Table XIII) what the quantities actually bought would have cost at pre-war prices.

TABLE XIII.  
Index Numbers.

	Actual expenditure on food, rent, clothing, etc., at selected dates	Cost of actual quantities at pre-war prices	Cost of pre-war budget at current prices
1910-1	100	100	100
1917 Feb. March	113	128	132
Aug. . . . .	—	138	142
1918 Feb. March	120	146	165
Aug. Sept. . . . .	135	166	183
Nov. Dec. . . . .	128	161	177
1919 March . . . . .	136	166	184
June . . . . .	152	180	195
Sept. . . . .	164	183	193
Dec. . . . .	173	200	205
1920 March . . . . .	195	214	214
June . . . . .	194	215	217
Sept. . . . .	—	222	223

Table XIII may be thus explained. Expenditure in 1914 was 5.78 fl. (ZQP) weekly, in Dec. 1919 10.00 fl. (Zqp), an increase of 73% (first column). If the same quantities had been bought in 1919 as in 1914 they would have cost 11.85 fl. (ZQP), an increase of 105% (third column); but if the 1919 quantities had been bought in 1914 they would have cost 5.00 fl. (ZqP), and the ratio of the actual cost to this is 2, which multiplied by 100 gives the number in the second column. Thus the third column gives the index number 100ZQP + ZQP, the usual type, and the second gives 100Zqp + ZqP (where q is changed at each date). It is argued above that the true measure of the cost of living lies between the numbers in the second and third columns. It can be seen that considerable modifications of diet took place between 1914 and 1918-9, but that either they had been reversed or that their effect on cost was nil by 1920.<sup>1</sup>

(A similar computation of the budgets in 1914 and 1918 in the United Kingdom gives 100Zqp + ZQP = 185, 100Zqp + ZqP = 202 and 100ZQP + ZQP = 212, for food only, numbers corresponding in order to the three columns just discussed.)

In Sweden an elaborate investigation (involving about 600 household budgets each kept for three periods of four weeks) was made in 1916, 1917, 1918. Besides calculating actual expenditure (Zqp) and the cost of a standard budget (ZQP) the food value in calories is computed (see Table XIV).

TABLE XIV.  
Index Numbers.

July	Actual expenditure on food	Cost of pre-war budget at current prices	Calories in food consumed	Cost of 10,000 calories
1914	100	100	100	100
1916	124	130	102	121
1917	155	173	90	172
1918	233	267	86	271

Expenditure thus increased less than the cost of a standard budget, but whereas in 1916 the nutritive value of the diet had increased, owing to some change from meat to cereals which afford more nourishment for the same price, in 1917 and 1918 the dietary was inferior owing to actual dearth and the cost of equal nourishment rose as rapidly as the food index number on the ordinary basis.

In Egypt it was estimated by its statistical department that the cost of living measured by the standard reached in March 1920 was for clerks 138% and for artisans 140% greater than that of the same standard in 1914 (Zqp : ZQP). For food, fuel and soap only the increases for artisans and labourers on the same basis were to March, July, Aug., Sept., Oct., and Nov. 1920 respectively 180, 181, 180, 180, 185 and 193% in Cairo; in parts of Egypt there was a fall in Nov. 1920.

REACTIONS OF PRICES AND WAGES

Prior to the war there was in the United Kingdom no direct reaction of retail prices on wages, for wage rates were deter-

<sup>1</sup>The double estimate is now given up and the index number is now computed on the standard of March 1920.

mined by the relation of the demand for and supply of labour, the exact rates being settled by the bargaining strength of employers and employed; since, however, real wages (wages expressed in commodities) were believed to be falling in the period 1900 to 1914 the determination of wage-earners to obtain higher money wages was strengthened and supported by a considerable body of public opinion and this no doubt improved their position in negotiations. On the other hand, whatever were the causes that brought about the general rise in prices that began about 1895, under the ordinary play of economic forces the rise, first apparent in wholesale prices, was followed after no long interval by increases in retail prices and in wages, and in general money wages may be expected to change in fairly close accordance with a gradual change in the price level. The immediate effect of rising prices in normal times is to stimulate commercial activity, increase employment (so that earnings rise before wages), and then to increase wage rates.

During the World War a new group of causes had effect. The connexion of currency with gold was broken, new purchasing power was obtained by the sale of securities held abroad, and the British Government was able to increase the amount of currency at will, by ordering goods and issuing new notes with which to pay for them. There was, for example, nothing to prevent the Government paying every week a £1 currency note to every wage-earner who liked to apply for it, and something of this kind was in fact done in the unemployment benefit after the Armistice.

The actual sequence of events appears to have been as follows. The increased demand for labour, due to the simultaneous need for munitions and equipment and the withdrawal of men from civilian occupations, soon resulted in full employment for nearly all persons capable of work; during the first year of the war this complete employment and the patriotic desire not to hinder the successful prosecution of the war (together with the opinion that the disturbance was temporary) deterred wage-earners from pressing for increased rates of wages in spite of the acuteness of the demand for labour. During 1915 it became apparent that retail prices had definitely risen and that there was no immediate prospect of a fall, and that real rates of wages had so far fallen that persons whose hours of work had not increased had suffered a serious fall in the standard of living, and that in the case of unskilled labourers wages were insufficient to purchase necessary food. The ordinary methods of bargaining were to a great extent suspended, partly because the Government was already a very important employer of labour and was provided with a bottomless purse by the printing press.

The first stage was to give a war bonus in many industries, either at a flat rate to all operatives on the ground that all persons required the same minimum ration of food, or on a slightly greater scale to the lowest-paid men on the ground that the better-paid could make more economies. The price of all goods rose to the extent that the wages affected were an element in their cost, with some exceptions, as in the case of railway services, in which the Government bore any loss. Prices of food which depended to a great extent on the world market prices were not directly affected to any great extent, being paid for by the realization of foreign securities, by the export of gold and by loans, but they nevertheless continued to rise.

The second stage was marked by an effort of wage-earners to obtain further increases commensurate with the increased cost of living and in many cases the acuteness of the demand for labour would have resulted in a great rise in wages; but the Government, by its growing importance as a purchaser of goods and its increasing direct control of industries, was in a position to dictate terms in so wide a sphere as to dominate all wages, and it was not strictly bound by the conditions that determined wages before the war. Courts of arbitration were established and by these and other methods wage changes were officially regulated. In determining wages the dominant consideration appears to have been the change in the cost of living

(as determined by the official measurement described above), though the increases awarded were not in strict proportion,—as indeed they could not be.

The series of increases in the middle and latter period of the war had a more direct reaction on retail prices than the earlier changes, for two reasons. The cost of coal rose with miners' wages, and this, together with the increased wage cost of food manufacturing processes and of wholesale and retail distribution and the increase of the farmers' wage bill (especially dairy farmers'), raised the price of many of the commodities ordinarily purchased by the working classes. Secondly, by the end of 1917 the supply of the majority of goods was limited by dearth, control of shipping or rationing, and was no longer sensitive to price; wages tended to be so raised as to command the purchase of nearly the same quantities of goods as in 1914 at the prices of 1917, but when they came to be spent the goods were not available in these quantities and competition raised the prices; in the case of the principal foods and of coal, prices were controlled and the amount purchasable rationed (except that of bread, which was sold at a loss made good by a Government subsidy); the surplus of wages was then expended on less necessary and unrationed goods whose prices rose enormously (eggs and pianos supply instances of this). If prices had not been controlled and wages had moved with the cost-of-living index number, an endless sequence would have been established, in which each increase of wages caused a rise of prices which was followed by a further enhancement of wages, the whole being financed by the issue of paper money, while the quantity of goods purchased was limited throughout to the same total, namely the goods available in the country. Actually the process was checked by the complete control (independent of home cost of production) of many of the foods included in the budget which determined the cost-of-living index number (e.g. of bread, flour, imported meat, cheese, tea, sugar), and by the partial and less successful control of foods influenced by the cost of home labour (potatoes, home-produced meat, fish, milk, butter); of the remaining articles, the supply of bacon of inferior quality was sufficient to make effective control unnecessary, margarine was manufactured by the Government and the price successfully kept low, and eggs (though nominally controlled) rose in price in accordance with the demand for them, coal was both rationed and controlled in price, and rent was restricted. Nearly the full force of the demand accentuated by surplus wages was felt in the price of clothes, and no doubt this had its effect on the increases of the cost of living and of wages during 1917-9 (see WAGES, for the "Cost-of-Living Wage").

After the Armistice, control was progressively relaxed as free supplies became available and the Government's importance as an employer was diminished. The close connexion between wages and the index number of the cost of living was maintained and extended, but the demand of labour was for an increase of wages above the level of 1914 more than proportional to the increase of prices—in fact, for a higher standard of living, and at the same time for a reduction of the hours in a normal week's work. There was a gradual return to pre-war conditions and the freer play of economic forces; wages had to be found by employers without direct reference to the Government's printing press, supplies of most goods became again sensitive to prices, imports had to be paid for by exports and the increased cost of the latter at once reacted (as indicated by the movements of exchange) on the former; so far as cost of labour is a constituent of price, prices of all goods (whether home-produced or imported) rose with that cost. The sequence of prices following wages and wages following prices must have a limit, and this limit appeared to have been reached with the break in prices in 1920 and the unemployment of 1921, but the date and manner of the climax were determined rather by world conditions than by the British labour policy.

How far wages kept pace with prices is shown approximately from the statistics given above and in the separate articles on WAGES and ON PRICES.

Prior to the war the movements are indicated by Table XV.

TABLE XV.

	General Course of Rates of Wages	Retail Prices of Food in London.
1902	93	91
1903	92	92
1904	92	92
1905	92	92
1906	94	92
1907	97	94
1908	96	96
1909	95	96
1910	95	96
1911	95	98
1912	98	103
1913	100	100
1914 (Jan. to July)	100	100

Both sets of figures in Table XV are computed from the XVIIth Abstract of Labour Statistics, except that the level of wages in 1914 is equated to that in 1913 on the ground of other information as to the absence of any important change. The basis of the computation of wages is not sufficiently wide to ensure minute accuracy, and since it depends only on changes of rates it does not allow for the slow but progressive increase of the average earnings of all workers due to the relative increase of the numbers in the better-paid occupations. The inclusion of fuel among retail prices hardly affects the numbers. Rent, however, is known (Cd.6955, p. xxviii) to have increased on the whole less than food prices between 1905 and 1912. The conclusion is that money wages increased nearly step by step with the cost of living in the 13 years in question.

No official index number of average wages had been published up to 1921 since 1913, but there is enough information to lead to a rough estimate (see Table XVI). It should be realized that the figures have not the necessary precision to allow minute calculations to be based on them (Bowley, *Prices and Wages in the United Kingdom 1914-1920*, p. 105).

TABLE XVI.

	General Course of Rates of Wages	Official Cost-of-Living Index Number
1914 July	100	100
1915 "	105 to 110	125
1916 "	115 to 120	145
1917 "	135 to 140	180
1918 "	175 to 180	200
1919 "	210 to 215	210
1920 "	260	250

The wage figures depend throughout on wages for a normal week (reduced in 1918 and 1919) or on changes in piece rates. During the war-years earnings increased so much more rapidly than wages, owing to various facilities for making additional money, that it is probable that an index number for earnings would show as high figures as those in the second column except in 1917. If, however, we pay attention only to rates for nominally the same work, it is seen that prices rose before wages from 1914 for at least three years. If the view is accepted, as argued above, that the official index number tends to show too great a rate of increase, then by July 1918 wages had caught up with prices, and, while in 1919 and 1920 they had slightly passed the official measurement of prices, in fact real wages increased in these years. In 1921 it was too early to trace the effect on wages of the fall of prices that began in the winter of 1920-1; apart from those cases where wages were bound to the cost-of-living figures by a formula, the first influence was felt in unemployment and consequently diminished average earnings, not on rates of wages.

Some examples of the formulæ connecting wages with prices are given in the article on WAGES, and that governing civil service and salaries is stated above. The general effect was to increase or decrease weekly rates in a lower proportion than prices, but where the proportion was applied to a standard wage higher than that in 1914 the whole increase over that date was at some periods greater than that of prices. Thus the

wages arranged in Jan. 1920 for a porter on the lowest scale were as follows:—

Rate of wages	Moneywages in relation to pre-war rate	Cost-of-living number	Real wages in relation to pre-war rate
22s. pre-war rate	100	100	100
40s. new standard rate	182	175	175
46s.	209	175	119
51s.	232	200	116
56s. Sliding scale rates	255	225	113
61s.	277	250	111
121s.	550	550	100

If then the cost-of-living index really measures the value of money the porter is better off when prices fall. Where such an arrangement took effect a slight check was put on the circular influence of prices on wages and wages on prices.

So far we have considered the interaction of wages and the prices that enter into working-class expenditure. There is still the question how wages have affected the cost of the unit of output. A bricklayer and his labourer averaged about 14d. an hour between them in the summer of 1914 and 45d. in the summer of 1920, i.e. three times as much as in 1914; owing to the reduction of hours their weekly rates were only 2½ times the former rate. In industries in general the reduction of hours was rather less, probably about one-tenth on the average, and while the index number for weekly wages was 255 in July 1920 that for hourly wages would be about 285 (July 1914=100). There is no certain information by which to connect the change in the cost of an hour's labour with the cost of a unit of output. On the one side it was generally alleged that the pace of work had been more or less intentionally reduced, though this is not substantiated by such figures for piece earnings as are available; and, though in factories there is some diminution of overhead expenses and waste time when the day's work is done in two instead of in three shifts, the general expense of salaries, interest on capital, rents, rates, etc., has to be met out of the diminished hours of work. No doubt the potential energy of the workman per hour is greater in a 48-hour than a 54-hour week, but the increase appears not to have been realized in 1919-20. On the other hand the high cost of labour and of materials (especially coal) stimulates employers to economize their use. In engineering especially many improvements in machinery were made during the war, the use of oil and petrol having replaced in some cases that of coal; in agriculture labour is saved by the use of oil-driven tractors. It is not possible to estimate the net influence of these factors; nor to state numerically in general how far the increase of wages has affected the cost of the product to the purchaser. In the article on WAGES are shown the scanty data relating to the general movement of wages in other countries than the United Kingdom, and these can be brought into relation with the index numbers of food and of the cost of living given above.

In Norway wages in the summer of 1918 were about 90% and the cost of living about 160% above the levels of 1914. In April 1919 various rates of wages were from 130 to 210% and the average had probably increased to 180% above 1914, while the cost of living was the same as in the previous year. In spite of reduction of hours weekly wages appear to have gained on the cost of living during the year May 1919 to May 1920.

In Denmark a more detailed table (see Table XVII) can be given:—

TABLE XVII.

	Hourly earnings	Cost of living
1914	100	100
1918 Aug.	200	182
1919 Feb.	224	190
Aug.	338	211
1920 Feb.	358	242
Aug.	396	262

Hours were reduced in 1919 till at the end of the year an 8-hour day was usual as compared with 10 hours before the war. Real weekly earnings had evidently increased considerably be-



fore 1920, and in April of that year it was agreed that future increases should be proportioned to the cost of living.

In Germany we have the computation shown in Table XVIII. (*Labour Overseas*, Ministry of Labour, London, Oct.-Jan. 1920, p. 51).—

TABLE XVIII.

Date	Average weekly earnings of male adult	Weekly minimum cost of living (four persons)	Earnings in proportion to cost of living
	Marks	Marks	
Aug. 1913 to July 1914	35	29	1.21
Aug. 1919	100	130	.77
Feb. 1920	170	254	.67
Nov. 1920	210	316	.76

The Official Year Book of New Zealand (1919) gives figures which are shown in Table XIX.—

TABLE XIX.

Year	Average minimum hourly rates	Weekly hours	Weekly rates	Retail food prices
1911	1000	1000	1000	1000
1912	1006	1000	1006	1035
1913	1036	998	1034	1055
1914	1087	986	1072	1102
1915	1094	985	1078	1218
1916	1152	983	1132	1290
1917	1200	982	1178	1384
1918	1258	982	1135	1513
1919	1418	979	1288	1537

More than the minimum may have been paid in skilled trades and other items of expenditure may have risen less than food.

Table XX. shows how earnings (as distinguished from rates of wages) moved in New York state in relation to the cost of living:—

TABLE XX.

	Average weekly earnings in factories in New York state	Cost of living index number for the United States
1914 Dec.	100	100
1915 "	107	101
1916 "	123	115
1917 "	149	139
1918 "	185	170
1919 "	209	193
1920 May	224	June 219

(A. L. Bo.)

COTTON, SIR HENRY JOHN STEDMAN (1845-1915), Anglo-Indian administrator (see 7.254), lost his seat in Parliament in 1910. He died in London Oct. 23 1915

COTTON, JAMES SUTHERLAND (1847-1918), British man of letters (see 7.255), died at Salisbury July 16 1918. He contributed articles on Indian subjects to the *E.B.* and spent the later years of his life cataloguing European MSS. relating to India in the India Office library.

COTTON AND COTTON INDUSTRY (see 7.256, 281).—The chief problems which faced the cotton industry after the beginning of the 20th century centred in the question of the supply of the raw material. Up to the outbreak of the World War the outstanding feature was the steady increase of the demand. The industry is unique in possessing fairly reliable statistics of the consumption throughout the world, these having been compiled with increasing completeness by the International Federation of Master Cotton Spinners and Manufacturers' Associations since 1904. The last issue before the war (March 1 1914) contained actual returns from the owners of 132 million spindles out of an estimated world's total of 145 millions, or 91% of the world's total mill capacity. These figures do not, of course, include domestic spinning, which in many countries, especially India and China, accounts for a large part of the local consumption, so that they must always be incomplete; but this does not greatly affect comparative statistics from year to year.

The possession of such statistics offered an opportunity to attempt a balance sheet of the world's production and consumption such as is given in Table A. During the war it was impossible to continue the world statistics of consumption of cotton of all kinds, but other figures for the American crop alone are available to bring the table down to date as far as was possible in 1921.

The causes of the increase of consumption may be briefly tabulated as follows:—

(1) The increasing wealth of the world, especially of those tropical and subtropical countries whose products are largely raw materials such as cotton, and which for climatic reasons happen to be also the largest cotton-using countries in the world.

(2) Improved methods of manufacture, and the discovery of new processes which made it possible to produce cotton fabrics of an entirely different character, quality and finish from those previously known. The old process of "mercerising," reapplied with new success, produced cotton fabrics with a finish and appearance closely resembling silk, while the additional process known as "schreiner" produced a surfaco like satin.

(3) Similar developments enabled cotton to be used not merely as an adulterant of, but as a really satisfactory substitute for, fabrics made from other textile materials, such as wool and linen, e.g. the raising process made it possible to produce cotton goods as much superior to the early attempts at woollen imitations as these were inferior to the real article. Cotton "damask" was also taking the place of the original linen.

TABLE A.—Balance of the World's Production and Consumption, 1904-20.

World's Commercial Crops and Mill Consumption. <sup>1</sup>				American Crop and World's Consumption thereof.			
Mean Crops.	Mean Consumption.	Balance.	Average Price of American, Indian and Egyptian.	Commercial Crop. <sup>2</sup>	Consumption. <sup>2</sup>	Balance.	Average Price American Middling.
Bales (000's omitted).			Pence per lb.	Bales (000's omitted).			Pence per lb.
1904-1905	19,648	17,736	+ 1,912	13,696	12,664	+ 992	4.93
1905-1906	17,266	18,214	- 948	11,443	12,081	- 638	5.94
1906-1907	20,815	19,523	+ 1,292	13,735	13,203	+ 532	6.38
1907-1908	17,354	19,393	- 1,839	11,436	12,112	- 676	6.19
1908-1909	20,229	19,828	+ 401	13,817	13,757	+ 60	5.80
1909-1910	17,216	19,148	- 1,932	10,592	11,734	- 1,162	7.86
1910-1911	18,854	20,222	- 1,368	11,986	19,084	- 6,898	7.84
1911-1912	22,157	21,495	+ 662	16,108	14,515	+ 1,593	6.09
1912-1913	21,503	22,302	- 799	14,106	14,715	- 609	6.76
1913-1914	23,399	22,296	+ 1,013	14,882	15,541	- 311	7.26
1914-1915				15,108	13,834	+ 1,274	8.22
1915-1916				12,038	14,812	- 1,874	7.51
1916-1917				12,941	13,906	- 965	12.33
1917-1918				11,907	12,282	- 375	21.68
1918-1919				11,640	10,600	+ 1,040	19.73
1919-1920				12,443	12,715	- 292	25.31

<sup>1</sup>For details see "The World's Cotton Crops," Appendix B.<sup>2</sup>Hester's figures. (New Orleans-Cotton Exchange.)

(A) Many entirely new uses were being discovered for cotton, of which two only need be mentioned on account of the enormous importance they acquired during the war, namely aeroplane cloth and motor-car tire fabric. At the same time the possibilities of cotton in entirely new forms of fabric were being worked out, e.g. in the hosiery trade, where their first use in cheap cotton hose has led to the evolution of entirely new classes of knitted garments and now even knitted piece goods, which is perhaps the most promising future development of all.

Table B shows the three chief crops, namely American, Indian, and Egyptian:—

wages; and second, the annual loss of an increasing percentage of the crop owing to the steady progress of the boll weevil eastward and northward throughout the belt, thus reducing the average yield per acre.

The position before the World War therefore was that the cotton world was faced with a striking application of the economic law of diminishing return. The greater the quantity of raw cotton they demanded from the world's producers, the higher its cost of production was going, with the result that the price was on the whole rising steadily, and more rapidly than the general level of prices as shown by the index numbers.

TABLE B.—Area, Yield and Prices of the World's Chief Crops, 1911-21.

Season	Area	Crop	Yield per acre	Liverpool prices (pence per lb.)		
				Lowest	Highest	Average
<b>American</b>	<b>Acres</b>	<b>Bales (500 lb. approx.)</b>	<b>Balos</b>	<b>Middling</b>		
1911-12	36,045	16,043	45	4-92	7-53	6-09
1912-13	34,283	14,179	46	6-05	7-19	6-76
1913-14	37,089	14,486	39	6-20	7-06	7-27
1914-15	36,832	13,287	41	4-25	6-50	5-22
1915-16	31,412	12,083	41	5-34	8-74	7-51
1916-17	34,985	12,976	37	8-12	19-45	12-33
1917-18	33,841	11,912	35	16-90	24-97	21-68
1918-19	36,008	11,603	32	15-24	24-77	19-73
1919-20	33,566	12,218	36	17-85	30-51	25-31
1920-21	35,878	13,500	38	6-38	27-10	
1921-22	26,519					
<b>Indian</b>	<b>Acres</b>	<b>Bales (400 lb.)</b>	<b>Lb.</b>	<b>Fine M. G. Broach</b>		
1911-12	21,615	3,288	62	4-68	6-06	5-11
1912-13	22,028	4,610	84	5-44	6-12	5-81
1913-14	25,020	5,065	81	4-69	6-25	5-56
1914-15	24,595	5,209	85	4-15	5-75	4-90
1915-16	17,736	3,738	84	5-15	8-40	7-19
1916-17	21,745	4,502	83	7-95	18-80	11-83
1917-18	25,188	4,000	64	16-70	22-90	20-81
1918-19	20,497	3,671	72	14-71	25-50	19-01
1919-20	23,353	5,796	99	17-55	25-35	21-70
1920-21	21,016	3,556	68	6-90	20-60	
1921-22						
<b>Egyptian</b>	<b>Feddans*</b>	<b>Kantars*</b>	<b>Lb.</b>	<b>F. G. F. Brown</b>		
1911-12	1,711	7,424	433	8-87	10-50	9-56
1912-13	1,722	7,533	437	9-56	10-15	9-82
1913-14	1,723	7,684	444	8-15	10-45	9-44
1914-15	1,755	6,490	369	6-30	8-30	7-34
1915-16	1,186	4,806	406	7-50	11-90	10-42
1916-17	1,656	5,111	310	11-60	31-50	21-56
1917-18	1,677	6,308	375	28-56†	35-56	30-97
1918-19	1,361	4,821	354	26-59†	30-19	27-85
1919-20	1,574	5,572	354	29-50†	99-00	60-34
1920-21	1,828	6,035	330	13-00†	71-00	
1921-22	1,286					

The figures in italics are estimates. \*A feddan is practically an acre, and a kantar 100 lb. †Sakel. ‡Good Bhowaugar.

From this table it will be seen that the American crop still in 1920 dominated the world's supply, forming about 60% of the whole, so that the fluctuations in the world's total were practically the same as those of the American crop. These latter fluctuations therefore acquired special importance, and a closer study of them revealed the fact that they were not merely accidental, but seemed to follow a certain rule. They presented an almost regular see-saw movement of area, crop and prices which may be summarized as follows:—A large American crop tended to produce a lower level of prices; but owing to the rising cost of production in America, and the fact that the price was barely sufficient to remunerate many of the growers, such a fall in price meant a reduction in the acreage planted the following season. This, other things being equal, produced a smaller crop, which meant an inadequate supply and a rise of price again, followed by a return to larger acreage, and so the circle went on. Thus the price of American cotton was constantly fluctuating in a way which was injurious alike to consumers and producers.

The crucial fact of the cotton situation lay in the increasing cost of production in America, which was due to several factors—first, the increased cost of everything used by the planter, and especially the rising labour cost of the crop owing to increased

*The Effects of the War.*—The first effect of the war was a tremendous slump in the price of cotton, because the expected cessation of demand happened to coincide with the largest American crop on record. All the exchanges were closed and nominal prices fixed. Under these conditions a difficulty very quickly arose with regard to the position of cotton as contraband. In view of its use for munitions as well as for many other semi-military purposes, it should in the interests of the Allies have been placed under embargo at once; but to do so under the then existing market conditions would have produced utter demoralization, and probably a serious dispute with America. It was not for about six months that the question was finally settled by a compromise under which a modified embargo was laid upon cotton; but this was converted into a formal declaration of contraband some months later. In the meantime prices had begun to recover, but not sufficiently to prevent the expected serious reduction of acreage throughout the world for the 1915 crops, which were the smallest on record for many years. In 1916 the American and Egyptian acreages were almost back to pre-war figures; but the average yield that year was poor, with the result that the crops were again much below pre-war normal. During 1916 prices rose sharply as the industry began to realize that demand was recovering in an unexpected way, and that the

huge surplus of the 1914 crop was rapidly being exhausted. It was not till the early summer of 1917, however, that matters came to a head, when the intensive submarine campaign made it impossible to maintain adequate imports of cotton. The Cotton Control Board was set up in Liverpool to ration the limited supplies available,<sup>1</sup> and at a later stage the British and Egyptian Governments set up a control scheme in Egypt to handle the 1918 crop by purchase.

Up to the end of the war, therefore, the supplies actually available remained very limited, and it was only due to the compulsory restriction of the consumption of the Central Powers that the supply was able to meet the demand at all. Unfortunately the Armistice was followed by a temporary period of hesitation and delay in getting things going again, which resulted in a serious fall in the price of cotton. This immediately reacted in a reduction of the acreage again in 1919 in America, and as this happened to coincide with another disastrous season, the 1919 supply was again extremely short. When on the top of this came the great post-war boom of 1919-20, in which the real needs of the world were exaggerated by the speculative hopes of those who saw fortunes in the reopening of the world's markets, prices simply broke all bounds and rose to figures which have perhaps never been equalled in the history of the trade. American cotton was over 2s. 8d. a lb., while the best Egyptian was over 10s. a lb. Indeed one of the features of the period was the extraordinary premiums paid for good staple cotton. This was largely due to the sudden rise of the motor trade in America. When it came out that at the beginning of 1919 there were over six million motor-cars in the United States (since increased to ten millions), it was obvious that the demand for that class of cotton would be large, and the Egyptian varieties were the most desirable for the purpose. The result was practically a corner in Egyptian, which drove the price up to \$200 per kantar (100 lb.) in Alexandria, against an average of less than \$20 before the war.

The subsequent slump in cotton was as dramatic as had been its rise. Within almost twelve months from the very top prices in Feb. 1920, American cotton had again fallen below pre-war prices, while Egyptian, which had so much farther to fall, reached almost the same point. The inevitable effect again was a movement for the reduction of acreage, which once more brought the world's crops for 1921 far below pre-war records.

<sup>1</sup> See *History of the Cotton Control Board* by H. D. Henderson (the Secretary) 1921.

In the meantime the world's trade had been brought almost to a standstill by the slump in demand everywhere. The extent of this is shown by the Federation statistics (Table C), which were resumed on July 31 1920 (the date of the cotton "season" having been in the meantime advanced by a month).

In their figures as at Jan. 31 1921, shown in the above table, it was possible to compare the consumption during the height of the boom with that of the pre-war year, and also with that of the first six months of the slump. The fact that the consumption even during the boom was not equal to the pre-war consumption is due, first, to the destruction of textile machinery in the devastated districts of France and Belgium; and, second, to the reduction of the hours of labour throughout most parts of the cotton world, which came into vogue immediately after the war. In 1919 the makers of textile machinery were utterly unable to cope with the demand for new machinery to replace that which had been destroyed during the war, or to make up the arrears of renewals which had fallen behind during the war. New machinery outside of these privileged requirements was practically unobtainable, with the result that the trade was unable to take full advantage of the boom in the demand by increasing its output. The high prices were therefore due not merely (if at all) to the shortage of the raw material, except perhaps in the case of Egyptian and other staple cottons, but rather to a shortage of cotton goods.

*Prospects in 1921.*—It may seem paradoxical to speak of possible scarcity at a time (Aug. 1921) when the actual demand for cotton goods seemed almost at a standstill, and the world was apparently over-stocked not only with cotton goods but also with the raw material. Yet there could be no practical doubt that the world would ere long be seriously short of cotton again; because it could only be a question of time till a return to something like normal conditions of demand would again lead to a consumption of cotton substantially in excess of what the world was producing. The abnormally large carry-over which was accumulated during the slump might prevent any scarcity arising within the immediate future, but it could hardly be doubted, unless the world was to face a prolonged period of practical starvation, that the consumption of cotton, which is the cheapest textile in the world for many other purposes besides clothing, could not permanently remain at the low level of 1921. The question was whether, when the demand came again, the supply would be as quick to respond as it was to contract when prices fell. It was extremely unlikely that pre-

TABLE C.—World's Consumption of Cotton by Countries and Varieties.  
(Calculated from the statistics of the International Cotton Federation.)  
(000's omitted throughout.)

Country.	Year to Aug. 31 1913.					Year to July 31 1920.					Half-year to Jan. 31 1921.							
	Total Spindles.	Consumption.				Total.	Active Spindles.	Consumption.				Total.	Active Spindles.	Consumption.				
		Amer.	Indian.	Egypt.	Sundries.			Amer.	Indian.	Egypt.	Sundries.			Amer.	Indian.	Egypt.	Sundries.	
Great Britain	55,653	3,667	54	392	161	4,274	56,900	2,891	56,429	137	3,513	56,352	1,091	23	152	46	1,312	
Germany	11,186	1,355	188	110	47	1,700	5,620	382	79	16	44	521	6,501	272	102	9	20	403
France	7,400	806	95	80	29	1,010	7,360	671	57	76	24	822	7,000	314	34	25	22	395
Russia	9,213	487	21	87	1,913	2,508	989	61	12	—	—	750	—	—	—	1	673	674
Poland and Finland		(Included under Russia)				837		(No statistics)			73	1,418	44	6	2	—	1	44
Austria		(Included under Austria)				837		(No statistics)			—	1,140	21	21	1	—	—	110
Czechoslovakia	4,909	627	154	33	233	1,033	1,603	86	8	1	3	98	3,584	89	17	2	2	114
Italy	4,600	571	175	19	25	790	4,340	549	147	36	26	740	4,506	302	11	12	4	489
Spain	2,000	285	34	20	19	358	1,800	305	40	25	20	390	1,806	138	7	7	1	180
Belgium	1,492	171	82	1	3	257	1,467	159	73	2	1	235	1,591	70	56	1	1	128
Switzerland	1,398	65	3	29	1	98	1,460	57	6	20	1	84	1,531	29	4	9	—	42
Other European	1,658	272	17	1	24	314	1,815	272	24	—	15	311	1,844	133	15	—	33	181
Total European	99,509	8,306	823	772	2,245	12,146	83,354	5,433	502	590	253	6,787	88,083	2,503	423	221	809	3,050
U.S.A.	31,505	5,553	—	201	32	5,786	35,499	6,010	12	243	166	6,425	36,051	2,221	5	58	36	320
India	6,084	94	2,081	1	1	2,177	6,420	0-5	2,032	4	10	2,046	6,703	1	1,109	2	2	1,114
Japan	2,300	425	993	16	155	1,589	3,155	700	1,150	21	204	2,084	3,804	337	723	7	—	46,173
Canada	855	113	—	—	—	113	681	118	—	—	—	118	1,100	78	—	—	—	80
Other	13,200	16	—	14	1,091	1,121	4,170	—	—	—	—	1,480	1,480	2,470	5	2	39	350
Total Non-European	43,944	6,201	3,074	232	1,279	10,786	49,925	6,837	3,194	268	1,854	12,153	50,188	2,642	1,839	108	453	5,042
WORLD'S TOTAL	143,453	14,507	3,897	1,004	3,524	22,932	133,279	12,270	3,696	867	2,707	18,940	138,271	5,145	2,262	329	1,262	8,092

\*No statistics for China. Estimated total spindles, over 1,600,000; consumption in 1920, 690,000 bales of sundries.

war conditions would ever again be reproduced in America. Then the crop was increasing slowly, but on the whole steadily, and in 1914 the actual growth was probably not less than 17 million bales, though this record total never came "into sight" during the season. It was clear that, at anything like the 1921 level of prices, and indeed under almost any conditions which could then be visualized as possible, the world could not look to America to equal that figure again or to resume the pre-war rate of increase. The difficulties in America were the extremely variable climate, the scarcity and high cost of labour, and the reduction of the average yield owing to the spread of the boll weevil; and although the cost of production would probably be substantially reduced again, it would take a price very much higher than the 1921 level to tempt the growers back again from the policy of diversification, which they had been taught since the war, to their old policy of cotton and nothing else.

The basic fact of the situation in 1921 was that prices were substantially below the cost of production, and this was a state of affairs which could not continue. It is true that where so much of the labour—and cotton is essentially a cheap-labour crop—is supplied by the grower himself and his family, they may for a time submit to a reduction of price which will not cover an adequate wage for their labour; but even where mobility of labour is low, as it is in the American cotton belt, such a state of affairs is bound in course of time to have its effect. It did so very strongly during the war when a large quantity of labour left agriculture in the cotton belt for the more highly paid industries in the Southern towns or in the industrial North; and while the subsequent slump had, for the time being reversed this tendency, it was extremely improbable that the South would again become resigned to a permanent lowering of its standard of living, especially as the policy of diversification in itself enabled them to meet this difficulty by supplying many of their requirements from their own land, instead of putting it all under cotton. The probability was, therefore, that it would require a substantially higher price than in pre-war times to induce America to return to her pre-war acreage.

A further point of detail may be noted. Part of the American crop before the war, the Sea Island crop, grown in Florida and Georgia, and on the so-called "Islands" of the coast of South Carolina, was the best cotton in the world, because its staple was the longest and finest; but this crop had by 1920 been virtually wiped out by the advent of the boll weevil in these districts, and the gap thus created would be extremely difficult to fill. The only supply of a similar kind which America could offer was the small crop of excellent cotton of Egyptian character which had for some years been growing in Arizona and California, especially in the Salt River Valley in the former state. The crop amounted in 1920 to 92,000 bales grown upon a total area of about 256,000 acres; but that was largely due to the high prices of 1919-20 and was not likely to be repeated. For the very best cotton, therefore, the world was entirely dependent on the West Indian Sea Island crop, which, however, was only about 7,000 bales, against the pre-war figure of about 100,000 from Florida and Georgia.

The supply of fine cotton was still further diminished by the serious reduction of the Egyptian crop, due to several causes, of which the most controversial was the view that drainage had not kept pace with irrigation, leading to a rising "water table" and partial water-logging of the lower zones in the Delta. The ravages of the pink boll worm in recent years had also contributed to the reduction of the average yield, which had become serious even before the war, and still more so since 1914. To counteract this reduction would require very heavy expenditure; and the further development of the Egyptian area was apparently dependent on the execution of large irrigation works, the chief of which, the White Nile Dam, above Khartoum, had been begun, though work was suspended in the meantime through lack of funds. The most striking development in Egypt, however, had been the replacing of the original Delta type of cotton (Afifi) by the new longer-stapled variety Sakelardes, the best of which has to some extent taken the place of the lost Sea Island.

In view of the reduction of the Egyptian crop the possible development of the Sudan became of the greatest importance. The Gezira scheme, which was expected to provide the larger part of the crop, was also dependent on large irrigation works on the Blue Nile, in course of construction in 1921. Other parts of the Sudan, such as Tokar, Kassala and certain areas on the Nile north of Khartoum, were of considerable promise, but large expenditure on transport and irrigation was still required there, especially for the Tokar and Kassala districts.

Great hopes have been entertained of the development of cotton of the ordinary American inch-staple in India, where it is regarded as relatively long-stapled in comparison with the  $\frac{3}{4}$  in. to  $\frac{1}{2}$  in. staple cotton which forms the bulk of the Indian crop. This development has had the active support of the Government, who in 1917 appointed a special commission to make a survey of the whole position (see *Report of the Indian Cotton Committee, 1919*). For many years to come, however, these improved cottons could not hope to form a large part of the total Indian crop. Since the formation of the British Cotton-Growing Association in 1902 attention had therefore been directed to other parts of the Empire, and much pioneer work had been done in proving the possibilities of many districts, especially in Africa. Distinct success has been achieved in West Africa, where the best cotton is of a good American type; and in Uganda and Nyasaland, where varieties akin to the American long-stapled upland have been produced. The development of all these districts was, of course, seriously checked by the war, and subsequently by the high cost of the necessary development works, such as transport. The war also left a great gap in the supply of skilled men of all kinds, whose services were everywhere required for the development of new cotton-fields. Everything depends in the first place on the maintenance of an adequate seed supply, which involves not only the finding of a suitable variety, but also the maintenance of a pure supply. Much had also been done in promoting improved methods of agriculture, in providing the necessary facilities for the ginning, baling, and handling of the crop, and for its marketing at adequate prices, especially in the case of superior varieties. In South Africa also excellent cotton had been grown in small quantities, but the necessary organization of the trade had still to be provided before it could be a success on a large scale. Other foreign Powers with colonies in Africa had also done a great deal for the development of cotton, but up to 1920 the total quantity produced in all these new areas in Africa (outside of Egypt) was relatively small, and the time when Africa could produce a million bales of cotton was still far distant (see *Report of the Empire Cotton-Growing Committee of the Board of Trade, Cmd. 523, 1920*).

In Australia there was little doubt that cotton could be successfully grown, either by rainfall or under irrigation; but there were problems to be faced with regard to the labour supply as well as the ordinary difficulties of organization.

There are many other countries which could provide large additions to the world's cotton supply if all the necessary conditions of the successful organization of the industry could be secured. Brazil, for example, could undoubtedly yield a very much larger crop than it has ever done (500,000 bales); but political as well as labour and other economic difficulties are apparently serious. The Argentine is also a country where excellent staple cotton has been grown, but labour seems to be the chief obstacle to its development on a large scale. Many of the other Latin-American countries, especially Mexico, also have great possibilities for cotton-growing. Peru produced a small crop (about 200,000 bales) of excellent staple cotton, a little below Egyptian in value, but much of it better than the staple American upland. The supply of the latter from America itself suffered a severe loss when the boll weevil appeared in the Mississippi Valley and drove out the old  $\frac{1}{2}$  in. long-staple cotton that used to be produced there. Subsequently, however, a great development took place in the production of new staple upland varieties of about 14 in. staple in southern Carolina, the Mississippi Valley and northern Texas; but their total supply probably did not exceed 250,000 bales per annum.

In Asia the chief crops before the war, apart from India, were in China and Asiatic Russia, including Transcaucasia. Statistically, the Chinese crop has always been a mystery, and its amount can only be guessed at about two million bales. The Russian crop had before the war risen rapidly to nearly 1½ million bales, part of which was of indigenous varieties similar to the Indian, and the remainder of good American quality; but this crop had been almost wiped out by the war, and it was not likely to recover as long as Russia remained in chaos.

*The Cotton Industry.*—The growth of the cotton industry throughout the world has already been indicated by the figures of spindleage given in the appended tables. Perhaps the most interesting feature up to 1921 had been the development of the American, Japanese and Indian sections of the trade. The first was largely due to the growth of the Southern mills, which had increased from ten million spindles in 1910 to 15 millions in 1920. In Japan the percentage increase of spindles had probably been greater than in any other country, though the total in 1921 was still comparatively small. The output of the Indian mills had also advanced in recent years, both in quality and quantity; but this unfortunately raised bitter controversy with regard to the Excise duties, which were imposed on the product of Indian mills in 1896 to balance the 3½ Customs duty<sup>1</sup> imposed for Revenue purposes on cotton goods imported into India. In 1917 the import duty was raised to 7½% without a corresponding increase in the Excise duty; and in 1921 the differentiation was still further increased by an addition of 3½% to the import duty. Table D shows the growth of the Indian cotton industry since 1911.

The facts with regard to the foreign trade of Great Britain in cotton and cotton goods are shown in Table E (See p. 769).

*Number of Operatives.*—In Table F are given the latest figures obtainable in 1921 as to the number of British operatives engaged in the cotton trade since the date of the Census of Production in 1907:—

TABLE F.—Numbers employed (in thousands).

Date.	Males.	Females.	Total.
1907	218	359	577
July 1914	274	415	689
Nov. 1918	144	349	493
July 1920	218	396	614
Nov. 1920	211	376	587

The controversial question of the employment of half-timers in the trade moved a step forward in England by the Education Act of 1918, which provided for their gradual abolition.

*Wages.*—With regard to wages, the outstanding feature of the British cotton industry was for many years the excellent organization both of masters and men, as the result of which wage disputes in the trade have, ever since the famous Brooklands Agreement of 1893, been reduced to a minimum. It is

<sup>1</sup> Both duties were originally 5% in 1894.

perhaps also due to this organization that, as a class, the cotton operatives of Lancashire are the most highly skilled, and enjoy the highest standard of living, of any section of the industry throughout the world.

In the Report (1909) by the Board of Trade in England into the Earnings and Hours of Labour of workpeople in the Textile Trades in 1906 (Cd. 4543) the average wages earned in the cotton trade for a full working-week were given as follows:—

Men.	Lads and Boys.	Women.	Girls.	All Workpeople
26s 9d.	11s 6d.	18s 8d.	10s 1d.	19s 7d.

The total wages bill for a full week at that time was £512,000 and the total number of operatives employed 523,030. It was also calculated that in 1906 the average annual earnings per head in the cotton trade were about £48. The number of hours constituting a full working-week at that time was 55½. Wages in the cotton trade in the United Kingdom are calculated on the basis of certain standard lists, the chief of which are known as the Bolton List and the Oldham List for cotton-spinning, and the Uniform List for cotton-weaving. In 1906 the wages actually paid were 5% above list prices for the Bolton and Oldham Lists and list prices for the Uniform List. Table G shows the changes since that date:—

TABLE G.—Changes in Wages of Cotton Operatives, 1906-21.

Dates.	Cotton Spinning.		Cotton Weaving.
	Bolton List.	Oldham List.	Uniform List.
	List Prices.	List Prices.	List Prices.
End of 1906	+ 5	+ 5	—
1907 and 1908	+ 10	+ 10	—
1909 to 1911	+ 5	+ 5	—
1912 and 1913	+ 5	+ 5	+ 5
July 1914	+ 5	+ 5	+ 5
June 1915	+ 10	+ 10	+ 5
Jan. 1916	+ 10	+ 10	+ 10
June 1916	+ 15	+ 15	+ 10
Jan. 1917	+ 15	+ 15	+ 15
Feb. 1917	+ 25	+ 25	+ 15
July 1917	+ 25	+ 25	+ 25
Dec. 1917	+ 40	+ 40	+ 40
June 1918*	+ 65	+ 65	+ 65
Dec. 1918	+115	+115	+115
July 1919†	+145	+145	+145
May 1920	+215	+215	+215
June 1921	+155	+155	+155
Dec. 1921	+145	+145	+145

\* From June 10 to Aug. 3 1918 the bulk of the operatives were working 40 hours, and from Aug. 3 to Oct. 26 45½ hours, in place of the normal 55½ hours per week.

† In July 1919 the week was reduced from 55½ hours to 48.

The changes made in wages during the war and since are described in Henderson's *History of the Cotton Control Board* above cited, from which the figures in the above lists since July 1914 have been taken.

TABLE D.—Indian Cotton Industry, 1911-21.

	1911-2	1912-3	1913-4	1914-5	1915-6	1916-7	1917-8	1918-9	1919-20	1920-1
Number of Mills	258	266	264	255	267	267	269	264		
Number of Spindles	6,427	6,495	6,621	6,398	6,676	6,670	6,614	6,591		
Number of Looms		87.6	91.6	103.3	108.4	110.8	114.8	116.1		
Number of Employees	237	259	261	260	292	277	284	290		
Cotton consumed: bales	2,050	2,095	2,143	2,103	2,198	2,198	2,085	2,044		
Yarn produced: lb.	625	688	683	652	722	681	661	615		
Goods produced: lb.	267	285	274	277	332	378	381	350	384	367
Yarn exports: lb.	151	204	198	134	160	169	122	64	152	83
Piece goods exports: yd.	81	87	89	67	113	264	189	149	197	
Piece goods imports: yd.	2,428	2,986	3,159	2,419	2,118	1,892	1,523	1,097	1,064	1,491
Classification of Yarns spun in India.										
Nos. 1 to 25		617	591	661	608	578	538	564	599	
Nos. 26 to 40		62.7	58.4	59.2	68.5	76.3	72.0	67.9	65.4	
Nos. over 40		3.4	2.2	2.0	4.6	5.8	4.8	3.6	2.1	
Classification of Yarns imported.										
Nos. 1 to 25			2.1		1.9	0.7	8.5	0.8	8.4	
Nos. 26 to 40			27.3		17.4	10.6	18.8	7.5	26.4	
Nos. over 40			7.9		4.9	3.6	6.7	3.6	5.0	
Customs Duty	£1,041	1,282	1,420	1,024	902	1,194	2,556			
Excise Duty	325	374	363	329	328	297	508			

TABLE E.—Foreign Trade, 1912-20.

Raw Cotton—Imports. (million lb.)									
	1911	1912	1913	1914	1915	1916	1917	1918	1919
American	1,682.4	2,164.9	1,584.8	1,284.4	2,022.8	1,646.9	1,186.2	976.0	1,170.7
Egyptian	364.3	491.3	402.7	336.1	448.5	356.7	277.9	388.5	416.9
Indian	79.4	56.6	51.3	104.3	94.0	80.1	76.0	59.5	63.6
Other British	14.6	21.1	20.6	23.6	24.4	18.9	22.8	14.1	24.1
Peru	22.7	29.1	38.4	37.0	38.4	44.6	23.6	41.2	46.5
Brazil	25.6	25.8	61.8	54.7	8.7	1.3	10.3	3.2	5.1
Other foreign	18.1	17.0	14.7	24.0	11.2	22.5	26.3	66.6	31.3
<b>TOTAL</b>	<b>2,207.1</b>	<b>2,805.8</b>	<b>2,174.3</b>	<b>1,864.1</b>	<b>2,647.6</b>	<b>2,171.0</b>	<b>1,623.2</b>	<b>1,489.1</b>	<b>1,958.3</b>
Values (million £.)	71.2	80.2	70.6	55.4	64.7	84.7	110.6	150.3	190.8
Re-exports	291.3	323.8	257.6	216.3	343.6	237.5	111.4	0.4	121.1
Values (million £.)	10.7	10.6	9.1	7.4	9.6	9.8	7.7	0.02	11.4
Yarns—Exports. (million lb.)									
	1911	1912	1913	1914	1915	1916	1917	1918	1919
Germany	54.5	54.8	51.9	32.4	—	—	—	—	3.0
Holland	43.2	45.1	39.3	43.1	59.7	64.2	31.7	0.007	40.8
Switzerland	7.2	7.9	9.5	6.1	9.3	6.4	6.0	6.9	8.9
Rumania	10.3	10.1	7.1	6.5	2.2	0.06	0.3	—	4.2
Turkey	9.2	13.6	9.8	5.9	0.3	0.01	0.03	0.08	8.4
France	4.6	4.9	5.0	3.5	38.1	26.5	33.7	66.5	49.9
Others	28.1	30.4	19.1	17.2	15.6	19.7	13.6	3.3	27.4
<b>TOTAL EUROPE</b>	<b>157.1</b>	<b>166.8</b>	<b>141.7</b>	<b>114.7</b>	<b>125.2</b>	<b>116.9</b>	<b>85.3</b>	<b>76.8</b>	<b>120.6</b>
India, etc.	39.3	41.8	40.5	39.9	39.6	28.9	19.8	9.6	10.1
Other British	8.1	10.1	9.0	7.4	7.4	7.4	7.2	3.8	3.6
<b>TOTAL EMPIRE</b>	<b>47.4</b>	<b>51.9</b>	<b>49.5</b>	<b>47.3</b>	<b>47.0</b>	<b>36.3</b>	<b>27.0</b>	<b>13.4</b>	<b>13.7</b>
U.S.A.	5.8	6.0	5.4	5.8	6.1	8.7	10.3	4.0	3.9
Other foreign	13.5	16.1	13.5	10.7	9.9	10.3	10.5	7.5	5.4
<b>GRAND TOTAL</b>	<b>223.8</b>	<b>243.8</b>	<b>210.1</b>	<b>178.5</b>	<b>188.2</b>	<b>172.2</b>	<b>133.1</b>	<b>101.7</b>	<b>162.6</b>
Values (million £.)	15.7	16.2	15.0	12.0	10.3	13.4	16.7	21.4	33.9
Piece Goods—Exports. (million yards)									
	1911	1912	1913	1914	1915	1916	1917	1918	1919
Germany	92.7	88.7	76.4	42.2	—	—	—	—	52.3
Holland	58.9	70.7	84.3	59.3	48.1	69.8	26.0	1.0	58.5
Turkey (including Asiatic)	467.7	394.4	360.7	270.8	10.1	12.2	31.4	38.5	332.7
Switzerland	83.2	81.7	80.0	51.3	60.8	70.2	82.0	75.2	116.6
France	13.9	14.1	12.8	17.8	220.4	120.2	123.6	183.5	90.2
Others	229.7	237.4	188.7	208.4	170.7	169.3	143.9	78.3	558.9
<b>TOTAL EUROPE</b>	<b>946.1</b>	<b>887.0</b>	<b>802.9</b>	<b>649.8</b>	<b>510.1</b>	<b>441.7</b>	<b>406.9</b>	<b>376.5</b>	<b>1209.2</b>
Egypt	126.6	261.6	266.6	202.3	243.1	289.7	319.5	361.6	183.2
British Africa	205.5	236.1	235.6	202.5	241.5	292.5	290.3	297.3	159.6
German Africa	13.7	13.2	9.6	5.6	0.7	7.1	6.9	5.4	5.4
Belgian Africa	9.5	10.8	6.8	3.4	6.5	15.5	31.4	16.3	9.4
French Africa	67.8	65.2	75.2	53.6	68.9	126.1	119.8	149.6	63.7
Portuguese Africa	25.7	21.6	21.4	15.8	9.0	20.5	17.6	16.2	10.2
Other African	119.4	152.3	95.6	99.7	129.0	139.4	124.0	129.1	83.2
<b>TOTAL AFRICA</b>	<b>768.2</b>	<b>762.8</b>	<b>710.8</b>	<b>582.9</b>	<b>692.7</b>	<b>890.8</b>	<b>909.5</b>	<b>975.5</b>	<b>514.7</b>
<b>EAST</b>									
East Indies	410.9	452.7	497.2	406.7	355.8	448.9	425.9	329.4	202.3
China	564.9	427.8	573.5	469.9	318.8	269.9	248.3	170.9	259.7
Japan	94.9	82.5	56.7	29.2	20.1	17.5	12.7	11.0	40.7
Persia	51.3	61.0	40.6	39.8	47.2	24.9	33.2	24.5	15.9
India (British Possessions)	2,543.0	2,944.4	3,247.9	2,701.4	1,992.1	2,055.3	2,001.6	1,009.7	826.3
<b>TOTAL ASIA</b>	<b>3,665.0</b>	<b>3,668.4</b>	<b>4,415.9</b>	<b>3,707.0</b>	<b>2,734.0</b>	<b>2,836.5</b>	<b>2,721.7</b>	<b>1,544.6</b>	<b>1,314.9</b>
Australasia	223.6	224.1	212.4	219.8	247.2	295.4	191.2	208.5	97.2
Other British	13.0	13.5	12.5	22.4	20.9	17.0	14.4	12.2	7.9
Other Foreign	23.3	23.8	19.3	14.4	6.0	8.4	5.4	5.9	7.6
<b>TOTAL AUSTRALASIA, etc.</b>	<b>259.9</b>	<b>261.4</b>	<b>244.2</b>	<b>256.6</b>	<b>274.1</b>	<b>320.8</b>	<b>211.0</b>	<b>226.6</b>	<b>112.7</b>
U.S.A.	57.1	48.1	44.4	59.9	47.1	66.3	67.7	29.3	40.8
Canada	78.2	89.6	112.6	76.7	67.1	78.0	73.2	35.1	22.9
West Indies	127.0	151.9	107.0	85.3	96.4	84.5	83.2	57.3	31.7
Latin America	752.2	743.7	637.4	317.5	327.0	335.6	505.0	454.3	276.8
<b>TOTAL AMERICA</b>	<b>1,014.5</b>	<b>1,033.3</b>	<b>901.4</b>	<b>539.4</b>	<b>537.6</b>	<b>764.4</b>	<b>729.1</b>	<b>576.0</b>	<b>372.2</b>
<b>GRAND TOTAL</b>	<b>6,651.7</b>	<b>6,912.9</b>	<b>7,075.2</b>	<b>5,735.7</b>	<b>4,748.5</b>	<b>5,254.2</b>	<b>4,078.2</b>	<b>3,992.2</b>	<b>3,253.7</b>
VALUES (million £.)	90.5	91.6	97.8	79.2	61.7	88.9	112.8	138.5	179.1
Other Cotton Goods	12.4	13.0	12.8	11.1	10.1	11.8	15.7	19.5	25.1
<b>TOTAL VALUES (million £.)</b>	<b>102.9</b>	<b>104.6</b>	<b>110.6</b>	<b>90.3</b>	<b>74.8</b>	<b>103.7</b>	<b>128.5</b>	<b>158.0</b>	<b>194.2</b>

Capital.—Much attention was attracted to the great movement in 1919-20 for the recapitalization of the British industry, which was to some extent inevitable. Owing to the demand for machinery and the high cost of production during the war, the book values of the mills represented only a fraction of the actual market value to which they had risen. The process of writing up the nominal capital of the companies to something approaching the actual market value of the plant was in itself harmless; but when the inevitable reaction came, those who had invested in the industry at the top of the wave seemed likely in 1921 to find it difficult to secure a normal rate of dividend on what had come again to be regarded as inflated values. The

table on next page, founded upon Mr. F. W. Tattersall's list of 200 typical joint-stock companies in the Lancashire industry, gives an interesting indication of the earnings of the trade.

It is obvious that the later dividends, and especially in 1919-20, were extraordinarily high, even after allowing for Excess Profits Duty, but in 1921 the reaction was in full swing.

Cotton-seed.—Since 1910 a great change has come over the relative position of cotton-seed among the innumerable commodities which contribute to the supply of the vegetable and animal oils and fats. Until then oils were classified pretty rigorously, on the one hand as soft and hard, and on the other as edible and non-edible. Soft or liquid oils, such as linseed,



TABLE H.—Earnings of the Cotton Industry, 1907-20.

Year.	No. of Companies.	Capital.		Profit. £-000's	Loss £-000's	Average Dividend
		Share. £-000's	Loan.			
1907	100	3,723	2,265	1,321		15½
1908	100	3,660	2,351	587		11½
1909	100	3,427	2,010		272	7½
1910	100	3,543	2,254		368	5½
1911	100	3,728	2,442	30		4½
1912	100	3,649	2,211	568		7½
1913	100	3,692	2,225	537		7½
1914	100	3,569	2,416	53		7
1915	100	3,613	2,500	75		5
1916	100	3,503	2,570	400		6
1917	90	3,602	2,250	516		7½
1918	40	1,678	953	577		16½
1919	23	946	370	340		21½
1920	100			2,264*		29½

\*Amount paid in dividends only.

cotton-seed, rape, whale oil, etc., could not be used, e.g. for the manufacture of margarine or soap, without a certain proportion of hard fat or solid oil, such as lard, coconut or palm oil. But the discovery of a new hardening process made it possible, by the removal of certain constituents from the soft oils, to convert them into a hard stearine, more solid even than tallow, and which could therefore be used for all purposes for which hard fats only had hitherto been employed.

Again, only American cotton-seed had till then been regarded as capable of producing an edible oil. This was due not so much to anything in the seed itself, but to the processes used in manufacture. American cotton-seed, being "white" or "fuzzy," had to be decorticated before crushing, i.e. the whole of the husk or hull, with the short fuzz adhering thereto, was separated from the meat or kernel, and the latter alone was crushed. In the case of the black Egyptian seed, however, which has practically no fuzz, and to a certain extent also Bombay or Indian cotton-seed, which has only a short fuzz, the whole seed was crushed, including the black hull; but the latter gave the oil a very dark colour, and in order to remove this certain chemicals had to be employed which left a distinct flavour in the refined oil, and this was thought to debar it entirely from use for edible purposes. Many other vegetable oils for other reasons were in a similar position; but the discovery of a process of deodorizing oils by blowing superheated steam through them made it possible to remove all objectionable flavour from almost any kind of vegetable oil.

The adoption of these two processes has gone far to revolutionize the relative values of the different vegetable-oil seeds, as now practically any kind of vegetable oil can be adapted for almost any purpose, either for culinary purposes or as a hard fat. They have also made it possible to use oils which hitherto had not been usable at all for either of these purposes.

During the same period considerable further knowledge has been gained as to the use of cotton-seed meal and cake for feeding purposes. A great deal has been done, by the combined use of different cakes possessing counteracting qualities, to make it possible to use certain cakes, such as Bombay, for purposes for which it had not formerly been thought suitable, e.g. Bombay or Indian cotton-seed cake was thought to be too astringent for cattle if used alone, but if given along with linseed or turnips, which possess laxative qualities, a good result can be obtained from the combination. Again, much has been learned as to the advantages of using particular cakes for special purposes; thus linseed cake was found to be the best for feeding cattle for the butcher, while Egyptian cotton-seed cake was looked upon as better than Bombay for dairy cattle.

Further future developments are indicated by the invention of a new method of removing from white cotton-seed, such as American, after the ordinary process of delinting, an additional supply of short fuzz in such a condition that it can be advantageously used for many purposes, such as paper-making, gun-cotton, artificial silk, etc. Indeed, this process of economizing by-products has gone still further, for a plant has within recent years been erected in America which, by a similar process,

removes the final remaining short fuzz from the cracked hulls after decortication, and even these have been put to good use for similar purposes. (J. A. T.')

**COUPERUS, LOUIS** (1863- ), Dutch writer, was born at The Hague June 10 1863, a member of a family of Scottish origin, banished from Scotland for political reasons in the 16th century. His early boyhood was spent in the Dutch East Indies, where his father was a prominent Government official. His first novel *Elise Vere*, written under the influence of Tolstoy, appeared in 1889 and was followed by *Noodla* (*The Footsteps of Fate*) in 1894 and *Estase*, the first of his novels to be translated into English (1892). He next produced certain imaginative and idealistic works, such as *Majesteit* (1895) and several volumes of prose poems. But the work by which he is best known in the English-speaking world is the series of "Books of the Small Souls," four novels entitled *Die Kleine Zielen* (*The Small Souls*), *Het Late Leven* (*The Later Life*), *Zielenscherming* (*The Twilight of the Soul*), *Het Helge Welen* (Eng. version *Dr. Adriano*) which, together with *Van Oude Menschen, de dingen de voorbijgaan* (*Old People and the Things that Pass*, Eng. version 1919) raised him to the first rank of European novelists. In this record of an ancient crime, buried deep in the hearts of the aged pair of lovers who committed it, and yet poisoning the lives of their descendants to the third and fourth generation, there is the austerity and inevitability of Aeschylean tragedy. Couperus travelled much in Greece and Italy and embodied his classical researches in historical romances such as *De Berg van Licht* (*The Mountain Light*) and its successor *De Komedianten* (*The Comedians*), and mythological romances such as *Dionysos* (1905) and *Herakles* (1913), as well as volumes of essays, sketches and short stories. The greater part of his work has been rendered into English by A. Teixeira de Mattos. His historical novel *Ishander* (concerning Alexander the Great) appeared in 1920.

**COURTHOPE, WILLIAM JOHN** (1842-1917) (see 7327), died at Wadhurst, Sussex, April 10 1917. He published a selection from Martial's *Epigrams* in 1914, and a volume of verse, *The Country Town and other Poems*, with a prefatory *Memoir* of him by A. O. Prickard, appeared in 1920.

See also J. W. Mackail, *W. J. Courthope* (1919).

**COURTNEY, LEONARD HENRY COURTNEY, BARON** (1832-1918), died in London on May 11 1918. His brother, **WILLIAM FRIDBAUX COURTNEY**, died in London Nov. 14 1913.

**COURTRAI, BATTLE OF** (1918): see YPRES and YSER BATTLES.

**COVENTRY, ENGLAND** (see 7342). Pop. (1911) 106,349, showing an extremely rapid increase of 52% over that of 1901. The normal engineering industries of Coventry were almost entirely transformed during the World War to munition production, which was carried on on a vast scale, and to the construction of aeroplanes, tanks, and guns. Among special industries newly established are the making of artificial silk and of telephone and other electrical apparatus. In order to meet the needs of an unusually rapid development, parliamentary powers were obtained in 1920 for the widening of several narrow streets and for the construction of two new arterial roads in the centre of the city. A new council house costing £100,000 was completed in 1917 and officially opened in 1920, and three branch public libraries were opened in 1913. The 14th century tower of Holy Trinity church was restored at a cost of £9,000 in 1918-20, and the 14th century Guildhall was in process of restoration in 1921. Coventry was created a separate diocese in 1918, the church of St. Michael being constituted into a cathedral.

**COWDRAY, WESTMAN DICKINSON PEARSON, 1st Viscount** (1856- ), was born at Shelley Woodhouse, Yorks., July 15 1856, and educated privately at Harrogate. He entered the family firm of S. Pearson & Co., contractors, ultimately becoming its head. Under him the firm greatly extended, undertaking many important contracts and acquiring large interests in Mexico and South America. In 1893 he unsuccessfully contested Colchester in the Liberal interest, but in 1895 was elected for the same seat, which he held until

1910. In 1864 he was treated a baronet, and in 1920 was raised to the peerage. He was in 1917 made president of the Air Board, and the same year was created a viscount. He was elected Lord Rector of Aberdeen University in 1918.

**COX, JAMES MIDDLETON** (1870- ), American politician, was born near Jacksonburg, O., March 31 1870. He was educated in the common schools, worked in a newspaper office, for a short time was a country school teacher, and later became a reporter on the Cincinnati *Enquirer*. Afterwards he went to Washington as secretary to Congressman Paul Sorg, of Ohio. On the latter's retirement he decided to enter again the newspaper field. In 1898 he purchased the Dayton *News* and five years later the Springfield *Press-Republic*, subsequently named the *Daily News*, these papers being known thereafter as the Newspaper League of Ohio. From 1909 to 1913 he was a member of Congress from the Dayton district and served on the Appropriations Committee. He was an active opponent of the Payne-Aldrich tariff measure. He was elected governor of Ohio for the term 1913-15, was defeated for the following term, then was reelected twice in succession (1917-21). At the time of his third election he was the only Democrat to be returned to state office, even the lieutenant-governor being Republican, and two-thirds of the congressional districts went Republican. In 1916 he was delegate-at-large to the Democratic National Convention. His career as governor was notable. Among the many reforms introduced under his guidance were a workmen's compensation law; a survey of occupational diseases with recommendations for health insurance; the elimination of the sweatshop; the establishment of a state industrial commission for dealing with questions of labour and capital; the provision of a minimum wage and a nine-hour day for women; mothers' pensions; ratification of the proposed woman suffrage amendment; the budget system for state expenditures; pure food laws; a "blue sky" law for protecting investors from unscrupulous promoters; the initiative and referendum; a Corrupt Practices Act; the indeterminate sentence for convicts; improvement of rural schools; the establishment of a state tuberculosis hospital and the extension of safety devices on railways and in mines. Many of these reforms were followed as models by other states. He was energetic in suppressing violence in connexion with strikes, his general policy being to hold local authorities responsible without recourse to the state militia. In at least one case he removed a mayor who had called for state troops. He favoured abolishing the Federal inheritance tax, believing that the state alone should have jurisdiction over inheritances. He opposed the excess profits tax but maintained that a small tax should be laid "on the volume of business of a going concern." He was a strong supporter of President Wilson's policies and especially of the League of Nations. He was often charged with opposing prohibition but repeatedly declared that all laws must be enforced. At the Democratic National Convention in 1920 he had from the beginning strong support for the presidential nomination. On the first ballot he stood third (with 134 votes); on the seventh ballot second (with 293 votes); on the twelfth ballot first (with 404 votes); on the thirtieth ballot he dropped to second (with 404 votes), on the thirty-ninth vote he again stood first (with 468 votes), and continued to gain thereafter until he was nominated on the forty-fourth ballot. Following his nomination he "stumped" the country, making the League of Nations the prominent issue but was overwhelmingly defeated by Warren G. Harding, the Republican nominee. The electoral vote was 404 for Harding and 127 for Cox. The popular vote was 16,138,000 for Harding and 9,142,000 for Cox. The vote in Ohio, the home state of both candidates, was 1,182,000 for Harding and 780,000 for Cox. The magnitude of the defeat, unprecedented in American history, was generally considered as due in part to the unwarranted character of the charges made by Cox himself during the campaign, but chiefly to a widespread revolt against the recent course of President Wilson, whose policies Cox upheld.

**COX, KENYON** (1836-1919), American painter (see 7.353), died in New York, March 17 1919. In 1910 he was awarded the

medal of honour for mural painting by the Architectural League. In 1911 he published *The Classic Point of View*, being lectures delivered that year before the Chicago Art Institute. Other works are *Artist and Public* (1914, largely reprints from periodicals); *Winslow Homer* (1914) and *Concerning Painting* (1917).

**COZENS-HARDY, HERBERT HARDY COZENS-HARDY, 1ST BARON** (1838-1920), English lawyer and Master of the Rolls, was born at Letheringsett Hall, Dereham, Norfolk, Nov. 22 1838, the son of William Cozens-Hardy, a Nonconformist solicitor in large practice at Norwich. He was educated at Amersham school and afterwards at London University, where he took his degree in 1858. He was called to the bar in 1862, and built up a large and very successful connexion, chiefly in Nonconformist and Liberal circles. He became a Q.C. in 1882, and was raised to the bench in 1899. In 1885 he was returned as Liberal member for Norfolk, retaining the seat until 1899. In 1902 he was made a lord of appeal, and in 1907 Master of the Rolls. In August 1913 he was appointed one of the three commissioners of the great seal during the absence of Lord Chancellor Haldane in Canada. In 1914 he was raised to the peerage, and in 1918 resigned the office of Master of the Rolls, being succeeded by Lord Swinfen. He died at Letheringsett Hall June 18 1920.

**CRACKANTHORPE, MONTAGU HUGHES** (1832-1913), English lawyer, was born at Nowers, Som., Feb. 24 1832, the son of Christopher Cookson of Nowers. The name of Crackanthorpe was assumed by him in 1888 on succeeding to the estate of Newbiggin, Westmoreland. He was educated at Merchant Taylors' school and St. John's College, Oxford, when he took his degree in classics in 1854, winning the Eldon law and University mathematical scholarships. He was called to the bar in 1859, and soon became well known not only as a barrister but as a keen student of criminology. He became a Q.C. in 1875, and from 1893 to 1899 was standing counsel to Oxford University. He took much interest in eugenics, and was president of the Eugenics Education Society from 1909 to 1911. He published *Population and Progress* (1907). He died in London Nov. 26 1913.

**CRADOCK, SIR CHRISTOPHER GEORGE FRANCIS MAURICE** (1862-1914), British admiral, was born at Hartforth, Yorks., July 2 1862, the son of Christopher Cradock. He entered the navy at the age of 13 and saw service in Egypt both in 1882 and again in the Soudanese expedition of 1891. He commanded the British Naval Brigade at the capture of the Taku forts and the relief of Peking (1900). He more than once performed personal feats of gallantry in saving life at sea and showed himself a bold and fearless leader in action. He was promoted captain after Taku, and rear-admiral in 1910. In 1912 he was granted the K.C.V.O. He published *Sporting Notes in the Far East* (1889); *Wrinkles in Seamanship* (1894) and *Whispers from the Fleet* (1907). Early in the World War he was given command of a British squadron in the Pacific consisting of the cruisers "Good Hope" (flagship) and "Monmouth," the armed merchantman "Otranto" and the light cruiser "Glasgow." His squadron was attacked off the coast of Chile (Nov. 1 1914) by five German warships, the "Scharnhorst," "Gneisenau," "Leipzig," "Dresden" and "Nürnberg." Though inferior in speed and gunpower he decided to attack. The "Monmouth" was sunk and the "Good Hope" was blown up whilst making for shore, Admiral Cradock going down with the ship.

**CRAM, RALPH ADAMS** (1863- ), American architect, was born at Hampton Falls, N.H., Dec. 16 1863. He was educated at the Westford (Mass.) Academy and the Exeter (N.H.) high school. He studied architecture in a Boston office, was for a time art critic on the *Boston Transcript* and in 1889 opened an architect's office in Boston. He had a profound knowledge of mediæval architecture and was an able advocate of the Gothic style, employed by him in many church and college buildings. Examples of his successful ecclesiastical work include St. Thomas's church, New York; Calvary church, Pittsburgh; St. Paul's cathedral, Detroit; the Fourth Presbyterian church, Chicago; and St. Alban's cathedral, Toronto. He was consulting architect for the cathedral of St. John the Divine, New York. He designed buildings for the Princeton graduate school, Sweet Briar College

(Va.), the Rice Institute (Texas), Williams College, Williams-town, Mass., and Phillips Academy at Exeter, N.H. In 1903 his plans were accepted for remodelling the U.S. Military Academy. In 1914 he was appointed professor of Architecture at the Massachusetts Institute of Technology.

His numerous writings include *Church Building* (1901); *The Ruined Abbeys of Great Britain* (1905); *Impressions of Japanese Architecture and the Allied Arts* (1906); *the Gothic Quest* (1907); *The Ministry of Art* (1914); *Heart of Europe* (1915); *The Substance of Gothic* (1916, Lowell lectures); *The Nemesis of Mediocrity* (1918); *The Great Thousand Years* (1918); *The Sins of the Fathers* (1919); *Walled Towns* (1919) and *Gold, Frankincense, and Myrrh* (1919).

**CRAMP, CHARLES HENRY** (1828-1913), American ship-builder (see 7.363), died in Philadelphia June 6 1913.

**CRAMP, CONCERNOR THOMAS** (1876- ), British Labour politician, was born at Staplehurst, Kent, on March 19 1876. He left school at the age of 12, and worked as a boy gardener to the local squire. At the age of 18 he left his native village and obtained employment as a gardener outside Portsmouth. In 1896 at the age of 21 he joined the service of the Midland Railway at Shipley, near Bradford, as a porter at 16s. a week of seven days of 12 hours each. He was later transferred to Masboro', then to Sheffield, and promoted to a passenger guard. He joined the Amalgamated Society of Railway Servants and first appeared as a delegate at its Birmingham all grades conference, 1907. Later he became delegate to the annual general meeting of the A.S.R.S. and in 1911 was elected to represent his district on the executive committee. He was elected president of the National Union of Railwaymen at the 1917 annual general meeting. During the World War he became a member of several Government committees including the Port and Transit Executive Committee, Committee on Adult Education, Consumers' Council, and Railway Advisory Committee. He stood for Parliament unsuccessfully as Labour candidate for Middlesborough at the general election in 1918. He was appointed Industrial General Secretary of the National Union of Railwaymen on Jan. 1 1920 and became a member of the Executive Committee of the Labour party.

**CRANE, WALTER** (1845-1915), English artist (see 7.366), died at Horsham March 14 1915.

**CRAWFORD AND BALCARRES, 26TH EARL OF** (1847-1913), British astronomer and orientalist (see 7.385), died in London Jan. 31 1913. He was succeeded as 27th earl by his son David Alexander Edward Lindsay (b. 1871), well known under his former title of Lord Balcarras as an art critic and connoisseur. He was appointed a trustee of the National Portrait Gallery, and has published *Donatello* (1903), and *The Evolution of Italian Sculpture* (1910). In 1916 he was included in Mr. Lloyd George's Cabinet as President of the Board of Agriculture and in 1921 became Lord President of the Council.

**CREWE, ROBERT OFFLEY ASHBURTON CREWE-MILNES, 1ST MARQUESS OF**, English statesman and writer (see 7.432), remained leader of the House of Lords through Mr. Asquith's first administration, and during the Coalition Government of 1915-6. Though he was not Lord Granville's equal in the difficult and delicate task of endeavouring to win the peers' assent to a succession of unpalatable measures of Radical reform, he contrived, by his courtesy and charm, to retain their liking and respect throughout the critical period beginning with the budget of 1909. He succeeded Lord Morley at the India Office in Nov. 1910, and attended, as Secretary of State, the King and Queen on their visit to India in the winter of 1911-2. He was responsible for the high acts of policy announced at the Delhi Durbar; the removal of the capital of India from Calcutta to Delhi, and the reunion of the two Bengals under a Governor-in-Council. At the coronation of King George he was promoted to a marquessate. In the first Coalition Government he was Lord President of the Council. He followed Mr. Asquith in declining to take office under Mr. Lloyd George; and after his resignation he continued to lead the independent Liberal opposition in the Lords.

**CRICKET:** see SPORTS AND GAMES.

**CRILE, GEORGE WASHINGTON** (1864- ), American surgeon, was born at Chili, O., Nov. 11 1864. After graduating from Ohio Northern University (1884), he studied medicine at Wooster University (M.D. 1887) and later at Vienna, London and Paris. He taught at Wooster from 1889 to 1900. He was professor of Clinical Medicine at Western Reserve University from 1900 to 1911, and was then made professor of Surgery. During the Spanish-American War he was made a member of the Medical Reserve Corps and served in Porto Rico (1898). He was made an hon. F.R.C.S. (London) in 1913. After America entered the World War he became major in the medical O.T.C., and professional director (1917-8). He served with the B.E.F. in France and was senior consultant in surgical research (1918-9). He was made lieutenant-colonel in June 1918 and colonel later in the year. He made important contributions to the study of blood pressure and of shock in operations. Realizing that any strong emotion, such as fear before operation, produced shock, he attempted to allay dread by psychic suggestion, also endeavouring to prevent the subjective shock which affects the patient, even when under general anaesthesia, by first anaesthetizing the operative region with cocaine for several days, if necessary, before operating. Thus nerve communication between the affected part and the brain was already obstructed when the general anaesthetic was administered (see *Anaest. Association*, 1914, with Dr. Wm. E. Lower). For his work in shockless surgery he received a gold medal from the National Institute of Social Sciences in 1914.

Among his works are: *Surgical Shock* (1897); *On the Blood Pressure in Surgery* (1903); *Hemorrhage and Transfusion* (1909); *Surgical Anemia and Resuscitation* (1914); *The Origin and Nature of the Emotions* (1915); *Man as Adaptive Mechanism* (1916); *A Mechanistic View of War and Peace* (1916) and *The Fallacy of the German State Philosophy* (1918).

**CROCE, BENEDETTO** (1866- ), Italian philosopher and statesman, was born at Pescasseroli, in the province of Aquila, Italy, Feb. 25 1866. He came of a family that counted among its members several jurists and magistrates. Born in the part of Italy formerly known as Greater Greece, it may be said of him without paradox that the development of his mind and character represented a modern incarnation of all that was subtle and profound in the Hellenic genius, linked with the best and wisest tradition of Roman civilization and of the Christianity that came to take its place. From the remote township of his birth, however, the branch of the family to which the philosopher belonged transferred itself soon afterwards to Naples, so that, like his predecessor Vico, Benedetto Croce may be correctly described as a Neapolitan. He studied at Rome and in Naples, afterwards adopting the life of an independent student and occupying himself especially with literary and with Neapolitan history. Much of his work that bears upon that period of youth is to be found in the volumes: *La Rivoluzione Napoletana del 1799*; *Saggi sulla letteratura italiana del Seicento*; *La Spagna nella vita italiana durante la rinascenza*; *Storie e leggende napoletane*. But Croce did not altogether neglect philosophy at this period. Towards his thirtieth year the study of philosophy and of history together occupied most of his attention. His principal works are contained in four volumes comprised under the general title *Filosofia dello spirito*: (1) *Estetica come scienza dell'espressione e linguistica generale*, (2) *Logica come scienza del concetto puro*, (3) *Filosofia della pratica: economia ed etica* and (4) *Teoria e storia della storiografia*. These were published between 1902 and 1913. With these may be mentioned certain volumes of essays, among which are to be noted those upon *Historical Materialism and Marxist Economy* (1896-1900); upon *Hegel* (1905); upon *Vico* (1910); and the *New Essays upon Aesthetic* (1920), which complete and carry further the first *Aesthetic*.

Croce only took part in the administrative work of Naples upon rare occasions and in moments of crisis. During the World War he developed a polemic directed against democratic-humanitarian conceptions and particularly those of President

Wilson, whose influence on the peace settlement was regarded by him as injurious to Italy. His writings on this subject have been collected in a volume entitled *Pagine sulla guerra* (Naples, 1910). In June 1920, when the Giolitti Government was formed with the programme of a reconstitution of the Italian State and of radical reforms, Croce (who had been a senator of the Kingdom of Italy since 1920) was asked to accept the office of Minister of Public Instruction. He agreed conditionally upon his programme being carried out. This programme was based upon the idea of a liberal reconstruction: he aimed at the reduction and simplification of the State schools combined with a more rigorous method of teaching, and at affording all facilities to, and indeed inviting the competition of, private instruction, fearless of the confession school, which in his view would be compelled to modernize itself in order to maintain competition with the State school. In 1921 he retired from office on the resignation of the Giolitti Ministry.

It may be said of the philosophy of Benedetto Croce that it has formulated the truth of the unity of the spirit in the form most acceptable to the Western world. Its fundamental motive is the serious consideration, in a continuous and concrete manner, of that union of philosophy and history which had been glimpsed by earlier thinkers, but had hitherto been pursued in a manner more or less capricious. For Croce, the only knowledge is knowledge of the history, in its widest sense, both of men and of what is called nature, or the history of the spirit. This knowledge, however, is by no means positivistic or empirical, but on the contrary it is dialectical and *a priori* synthetic, brought about by the spiritual categories; and from it there constantly arise new problems, an ever new position of the fundamental categories. The treatment and solution of these problems is what is called "philosophy" in the strict sense of the word, which for that reason coincides with methodology speculatively understood. In the treatment of the spiritual categories, Croce laid special stress upon those which had been least elaborated and least studied.

A vivid new light is shed by him upon certain problems, such for instance as those of the imagination or intuition, the source of Art and the theme of the *Aesthetic*, upon pure will, the source of Economic of Rights and of Politics, treated by *Economic*. The more precise determination and configuration of the categories and their mode of acting, by means of which is negated and solved the concept of an external reality and of nature placed outside the spirit and opposed to it, led Croce to an absolute spiritualism, widely different from the pan-logicism of Hegel and his school, which only seemed to solve the dualism of spirit and nature and really opened the door to the notion of a transcendental God, as became clear in the development of Hegel's theory at the hands of the right wing of his school.

In the *Philosophy of the Practical*, but more especially in the work entitled *What is living and what is dead of the Philosophy of Hegel* Croce criticizes the concrete treatment of the opposites, and shows that on the contrary every opposition has at bottom a distinction from which it arises, and that therefore the true unity is trinity-distinction, which is development and, as such, opposition that is continuously surpassed and continually re-appearing to be again surpassed. Another important conception connected with the preceding is the infinity of philosophy, which arises out of history and is as it were a reflection from history, varying at every moment and always solving a problem by placing alongside its solution the promise of a new history and therefore of a new problem and a new philosophy. Croce's substitutes for the old formula "system" the new formula "systematization." He thus admits that to philosophize is to systematize, but holds that every systematization is narrowly circumscribed, and is therefore to be solved and completed with ever new systematization. This scepticism and relativism are superseded by a historical philosophy, and the *absoluteness* of truth is affirmed, but the notion of a definite truth is at the same time both negated and satirized.

The philosophers from whom Croce learned most are Vico, the author of the *Scienza nuova*, and Hegel, but the thought of all other thinkers flows in his writings, in conformity with its historical character, and for this reason may, for instance, be found in it traces of some of Hegel's most active opponents, such as Herbart.

But the origin of the philosophy of Croce is the need, so keenly felt in our time, of a philosophy that shall be both realistic and idealistic, in which the fact will not drive out thought and thought will not go beyond the fact; in short, of a philosophy of immanence. The religious feature of this philosophy, against which has often been brought the accusation of excluding religion, resides in the consciousness of the unity of all and of the perpetual creation of the world by the spirit, as though it were a poem that the spirit is eternally composing, to which each individual contributes his strophe, or it may be only his line or his word: this poem has its end in itself and in its rhythm has beauty and joy, as well as labour and sorrow. This conception sets us free from the antithesis of optimism and pessimism.

Croce has elaborated the various philosophic *aprioristic* sweeping of the various theories to which they give rise, and he has completed the doctrines with their history, either, as in the case of the *Aesthetic*, with a mastery historical survey of previous speculation of the subject, or in a more modest form in appendices. It is only possible to allude briefly here to the different conclusions that he has attained in treating the various problems, as for example in *Aesthetic*, the unity of art and language, of intuition and expression, the negation of particular arts, the refutation of literary and artistic classes, the criticism of rhetoric, of grammar and so forth; and in the *Philosophy of the Practical* or of Practice, the conciliation of the antitheses of utilitarianism and moralism, the critique of precepts, of laws and of casuistry, the new conception of judgments of value, the constitution of a philosophic economy side by side with the science of Economy, the resolution of the Philosophy of rights in the Philosophy of economic, and so forth. It is important to note that, in conceiving philosophic studies to be all one with historical studies and attaining to this unity in himself, he cultivated historical studies to an equal extent with purely theoretical and speculative studies, concentrating especially upon the history of thought and poetry. Among his special works may be mentioned his *History of the four volumes of Letteratura della nuova Italia* (1860-1910); his essays upon Goethe, Ariosto, Shakespeare, Corneille, and the *Poetry of Dante*; his two volumes *Storia della storiografia italiana del secolo XIX.* and the collection of essays entitled *Una famiglia di patrioti*.

Croce, occupied with such studies as those mentioned, also found time to edit numerous texts and miscellaneous collections and composed many bibliographies, in addition to editing the *Critica*, in many respects the profoundest and widest in scope of all the European literary and philosophical reviews. In the work of this review his chief collaborator was Giovanni Gentile, but Croce contributed most of the literary and much of the philosophic criticisms.

The works of Croce have been translated into many languages. Douglas Ainslie was the first in Great Britain to draw attention to his importance as one of the leaders of European thought, and made him known in many articles and lectures both in Great Britain and in America. He also translated and published the complete *Philosophy of the Spirit* in four volumes (the *Aesthetic*, the *Logic*, the *Practical*, with Macmillan; the *Theory and History of Historiography*, with Harrap). The work on Vico has been translated by R. G. Collingwood, and that on *Historical Materialism and Marxism* by C. M. Meredith, the *What is living and what is dead of the Philosophy of Hegel* (Macmillan), and the *Bronary of Aesthetic* (Rico Instituto, Texas), the volume *Shakespeare, Ariosto and Corneille* (Henry Holt & Co., New York), and the *Poetry of Dante* by Douglas Ainslie.

Among the numerous studies of Croce may be mentioned Dr. H. Wildon Carr's work *The Philosophy of Benedetto Croce* (Macmillan), and the further development of the same in his essay *Time and History*, where will be found a parallel and a distinction between Croce and Bergson (*Proceedings of the British Academy*, vol. viii.); and the very full and complete bibliography by G. Castellano, *Introduzione allo studio delle opere di B. Croce: Note bibliografiche e critiche* (Bari, Laterza, 1920).

Croce has himself composed a mental autobiography: *Contributo alla critica di me stesso* (Naples, 1918, limited to one hundred numbered copies for private circulation), and also a brief history of his native place and of his family (*Montenerodomo, storia di un comune e di due famiglie*, Bari, 1915), and another opuscle upon the house in which he lives: *Un angolo di Napoli* (Naples, 1912).

(D. A.; G. C.)

**CROCKETT, SAMUEL RUTHERFORD** (1860-1914), Scottish novelist (see 7.477), died at Avignon April 20 1914.

**CROMARTY** (see 7.483).—Before the outbreak of the World War the Cromarty Firth was surveyed as an advanced base for the main battle fleet in the event of a war with Germany, and the erection of defences at Cromarty was begun in 1912 and had made considerable progress by the outbreak of war. When the war began, Scapa Flow (see SCAPA FLOW) was adopted as the chief naval base because of the more restricted space of the Cromarty Firth and in view of the unsuitability of the narrow single entrance to the firth for sweeps into the North Sea and for the guarding of the northern exits. The existence of an anti-submarine defence made Cromarty important in the early months of the war. It was used throughout the war as a coaling station and was one of the nine "Trawler Stations" under the control of the Admiral of Patrols. Cruiser squadrons, with their destroyer flotillas, used Cromarty as their base, and it was from Cromarty that the "Invincible" and "Indefatigable" started for the battle of the Falklands. One of the most serious naval disasters of the war occurred in the harbour of Cromarty on Dec. 30 1915, when the armoured cruiser "Natal" was destroyed by an accidental explosion.

**CROMER, EVELYN BARING, 1ST EARL OF (1841-1917)**, British statesman and diplomatist (see 7.484). Lord Cromer's life was prolonged for nearly ten years after his return from Egypt; and, in spite of enfeebled health, culminating in a serious illness in 1914 from which he never completely recovered, he took an important share in political, social and literary movements at home. He was constant in his attendance in the House of Lords, and indefatigable in the work of its committees; he was a leading member of the free trade section of the Unionist party; he was active in opposition to female suffrage, and in combating anti-unionist propaganda. Besides publishing his two volumes of *Modern Egypt*, he composed several addresses and pamphlets, wrote frequently for the periodicals, and from 1912 onwards was a regular contributor of signed articles and reviews of books to the *Spectator*—his vigorous and informed writing becoming an attractive feature of the paper. When the British Protectorate of Egypt was proclaimed, he completed his history of the modern development of that country in a small volume entitled *Abbas II.*, containing matter which it would have been indiscreet to publish so long as Abbas remained Khedive. While he was forward in promoting the study of Oriental languages, his strongest affection was for the Greek and Latin classics with which he had only become acquainted in mature life; he became president of the Classical Society, and endowed a Greek prize for the British Academy. In the critical period of which the main features were the budget of 1909 and the Parliament bill of 1911, Lord Cromer played an energetic part. He failed to prevent the rejection of the budget by the House of Lords; but he was successful in his untiring efforts to persuade moderate Unionist and cross-bench peers to counter the "Die-hard" movement, and to vote for the Parliament bill rather than force the Government to swamp the House by an unlimited creation. It was in the performance of another patriotic duty, during the World War, that he met his death. In spite of age and indifferent health he accepted the laborious and invidious task of chairman of the special commission to inquire into the abortive Dardanelles operations. The sittings occupied the autumn of 1916, and while engaged on the draft report he was seized in Dec. with an attack of influenza. Before he had recovered, he resumed the work of the commission, which completely broke him down. He died a few weeks after the beginning of the new year. Seldom has there been a life more singly and successfully devoted to the good of his country.

See Lord Sanderson's *Memoir of Evelyn, Earl of Cromer (1917)*. (G. E. B.)

**CRONJE, PIET ARNOLDUS (1840-1911)**, Boer general (see 7.501), died at Klerksdorp, Transvaal, Feb. 4 1911.

**CROOKES, SIR WILLIAM (1832-1919)**, English chemist and physicist (see 7.501), died in London April 4 1919. He was given the O.M. in 1910.

**CROOKS, WILLIAM (1852-1921)**, British Labour politician, was born at Poplar April 6 1852. After spending his early years in the workhouse of which he afterwards became chairman of the Board of Guardians, he started work at the age of 14 as a cooper's apprentice, and soon became an ardent trade unionist. His long career of public work began in 1882, when he was made trustee of the parish of Poplar and Library Commissioner. In 1892 he became a member of the L.C.C., on which he worked continuously for 28 years. From 1898 to 1906 he was chairman of the Poplar Board of Guardians, and in 1901 mayor of Poplar. In 1903 he entered Parliament for Woolwich, and, except for one short interval in 1910, continued to represent that constituency until his resignation in 1921. On the outbreak of the World War he entered wholeheartedly into the work of recruiting and in 1916 he was made a Privy Councillor. Continued ill-health compelled his retirement from politics in Feb. 1921, and he died in Poplar hospital on June 5 1921.

**CROTHERS, SAMUEL MCCORD (1857- )**, American clergyman and author, was born at Oswego, Ill., June 7 1857. He was educated at Princeton (A.B. 1874), Union Theological Seminary (1874-7), and the Harvard Divinity School (1881-2).

Ordained as a Presbyterian minister in 1877 he was a pastor in Nebraska, Nevada, and California (1877-81). He became a Unitarian minister in 1882, called to Brattleboro, Vt. (1882-6), St. Paul, Minn. (1886-94), and Cambridge, Mass. (since 1894). An inspiring preacher and a very popular public speaker, he won a still wider audience by his essays, which recall the quaint humour of Charles Lamb.

Among his best known volumes are:—*The Gentle Reader* (1903); *The Understanding Heart* (1903); *The Pardoner's Wallet* (1905); *The Endless Life* (1905); *By the Christmas Fire* (1908); *Oliver Wendell Holmes and His Fellow Boarders* (1909); *Among Friends* (1910); *Humanly Speaking* (1912); *Three Lords of Destiny* (1913); *Meditations on Votes for Women* (1914) and *Pleasures of an Absent Lord* (1916).

**CROWDER, ENOCH HERBERT (1859- )**, American soldier, was born in Missouri April 11 1859. He graduated from the U.S. Military Academy in 1881 and while detailed as commandant at the university of Missouri won in 1886 the degree of LL.B. in the law school. He was appointed major judge-advocate in 1895. He served in the Philippine Islands (1897-1901), was observer with the Japanese army in Manchuria (1904-5), and was in Cuba as Secretary of State and Justice (1906-8). He was provost-marshal general from May 1917 to July 1919, and as such had full control of the U.S. machinery of conscription in the World War, which he conducted with much success. He was reappointed judge-advocate general in 1919, and the same year invited by the Government of Cuba to advise in connexion with changes in the election legislation there. General Crowder was recognized as an exceptionally authoritative legal adviser in military affairs. In his book *The Spirit of the Selective Service* (1920), he described the method whereby within 18 months after America had entered the World War 2,000,000 men were in France, almost as many more were in cantonments, and altogether no fewer than 24,000,000 had been registered and classified.

**CROZIER, JOHN BAPTIST (1853-1920)**, Protestant Archbishop of Armagh, was born at Ballyhaise, co. Cavan, Ireland, April 8 1853. After a distinguished career at Trinity College, Dublin, where he took his degree in 1872, he was ordained in 1876. From 1885 to 1897 he was vicar of Holywood, co. Down. In 1896 he became honourable secretary of the General Synod of the Church of Ireland, becoming in the same year a canon of St. Patrick's cathedral. In 1897 he was elected Bishop of Oswoy, was translated in 1907 to the see of Down, and in 1911 succeeded Dr. Alexander as Archbishop of Armagh and Primate of All Ireland. In 1912 he took a conspicuous part in the agitation against the Home Rule bill, and presided over the monster meeting of Unionists held at Balmoral, Belfast, on Easter Tuesday. In the Irish Convention of 1917-8, he and Dr. J. H. Bernard (then Archbishop of Dublin), represented the Church of Ireland. At the close of the Convention the Archbishop joined Dr. Mahaffy, the provost of Trinity, in presenting a minority report advocating a solution of the Irish question on the lines of the Swiss federalism. He died at Armagh April 1 1920.

**CROZIER, JOHN BEATTIE (1849-1921)**, British philosopher, was born at Galt, Can., of Scottish parentage April 23 1849. He was educated at the local grammar school, where he was a scholarship to Toronto University, which he was, however, obliged soon to surrender owing to ill-health. He returned to the university four years later and took a course in medicine, graduating in 1872. He then came to England, bought a practice in London, and began a systematic study of philosophy and economics. His first publication, *The Religion of the Future* (1880), attracted little attention; but *Civilization and Progress* (1885) reached a 4th edition and was translated into Japanese. His *History of Intellectual Development* (1897-1901) was followed by the grant of a Civil List pension, some compensation for failing eyesight and the loss of his medical practice. His further publications included *My Inner Life*, an autobiography (1898); *The Wheel of Wealth* (1906); *Sociology applied to Practical Politics* (1911); and *Last Words on Great Issues* (1917). He died in London Jan. 8 1921.

**CROZIER, WILLIAM** (1855- ), American soldier (see 7.590), was detailed in 1912 as president of the Army War College and the following year was reappointed chief of ordnance with the rank of brigadier-general. He was made major-general, chief of ordnance, U.S.A., in 1917, and the provision of munitions in the World War was under his charge until Dec. 1917. He was then made a member of the War Council, and in the discharge of this office was in France and Italy for the first half of 1918. For the remainder of the year he was commandant of the N.E. Department, U.S.A., retiring from active service in December.

**CRYSTALLOGRAPHY** (see 7.569).—The geometry of the external forms of crystals may be said to have been completely worked out. The 32 crystal-classes differing from one another in their type and degree of symmetry and the six crystal-systems into which these classes can be grouped are now well established. The same is also true of the geometrical conceptions of the internal structure of crystals (though a good general account is still wanting). It is known that there are 230 possible types of homogeneous point-systems and that these are referable to 14 kinds of space-lattices. Recent work has been in the direction of attempting to trace a connexion between the internal structure of crystals and their chemical constitution. Here there is ample scope for speculation; but since 1912, when X rays provided a new method of investigation, some real advance has been made. By this method it is possible not only to determine the internal structure of crystals, but also actually to measure the distance between the atoms.

Crystals consist of a homogeneous assemblage of particles, and these particles are marshalled in certain definite ways. The grouping around any one particle (except those on the boundaries of the crystal) is the same as that around every other particle of the same kind. Further, the particles are arranged at regular intervals along straight lines. Throughout the structure there are several parallel sets of such lines, and these lie in several parallel sets of planes also at regular intervals apart.

An example of such a structure is the simple cubic space-lattice represented in fig. 1. Here the particles (all of the same kind) are placed at equal distances, say  $a$ , along parallel lines in three sets at right angles; the distance between the parallel lines in each plane and between the parallel planes of lines being also  $a$ . That is, the particles are situated at the points of intersection of a system of lines that form a square network or lattice in three dimensions. Or the structure may be regarded as a stack of small cubes each with a quarter of a particle at every corner; the four adjoining cubes at each corner then providing the whole particle. In this grouping, any one particle is surrounded by a set of 6 similar particles at distance  $a$ ; further, it is surrounded by 12 particles at distance  $\sqrt{2}a$  (i.e. the diagonal of the square); and by 8 other particles at distance  $\sqrt{3}a$  (i.e. the diagonal of the cube).

It is clear from fig. 1 that the three sets of lines are parallel to the edges of the cube, and that they lie in planes parallel to the faces of the cube. But it is to be noticed that the particles also lie in other sets of parallel lines, and that these lines fall in other sets of parallel planes. Certain of these additional lines and planes of particles are represented more prominently in fig. 2, which is drawn on a smaller scale with a larger number of particles (but to avoid confusion only those on the surface of the solid are marked). In this figure the three front edges of a portion of the main cube are truncated by planes of the rhombic-dodecahedron, and one corner has been cut off symmetrically by a face of the octahedron. (Since the octahedron face intersects both the cube and the rhombic-dodecahedron faces, its outline is hexagonal.) It will be seen that the several layers of particles parallel to any one of these faces are continuous over the other faces, although the particles themselves are ranged along lines of different directions. Hundreds of different planes of particles can, in fact, be traced out in such a structure; and it is important to remember that these structure planes are parallel to possible external faces on the crystal. A close relation exists between the Millerian indices of these faces and the number of particles along certain lines in the corresponding planes. The dotted lines on the front cube face in fig. 2 represent the intersections or traces of such planes with the indices: (111), (211), (311), etc.; (221), (321), etc.; (331), (431), etc.; respectively for the lines from right to left. The seven planes of which the indices have just been given necessitate by symmetrical repetition the presence of 93 other structure planes, or, in all, 200 external crystal faces.

It will be further seen from a study of fig. 2 that the spacing between the particles is not the same on each of the faces (allowance being made for foreshortening in the drawing: only on the front

cube face are the particles represented at their true distance apart). On the cube faces the distances each way are, of course,  $a$ . On the faces of the rhombic-dodecahedron they are spaced at distance  $a$  in one direction, but along the second direction at right angles at distance  $\sqrt{2}a$ . On the octahedral face there is, instead of a rectangular grouping, a triangular and hexagonal pattern with the particles spaced at distances  $\sqrt{2}a$  in three directions. It follows therefore that the number of particles on each of the faces is not the same for equal areas. The network of particles is closer on the cube face than on the rhombic-dodecahedron, and more open on the octahedron. This "reticular density" of the different faces is a question of importance and is closely related to the cleavage of crystals. Minerals with cubic cleavage (e.g. rock-salt and galena) would be expected to be of this structure.

In addition to the spacing of the particles in the planes, there is also to be considered the distances between the planes themselves. This is represented in fig. 3 by means of vertical sections through the structure (fig. 2) perpendicular to the respective planes. In fig. 3a the spaces between the cube planes is, of course,  $a$ , and the particles are also spaced at distance  $a$ ; the pattern being, in fact, that on a cube face perpendicular to the first. In fig. 3b the distance between the rhombic-dodecahedron planes is given by half the diagonal of the cube face, namely  $a/\sqrt{2}$ ; and the particles are at distances  $a$  apart. Here, however, the section-plane intersects lines of particles only in alternate rhombic-dodecahedron planes. In fig. 3c the distance between octahedron planes is given by one-third the diagonal of the cube, namely  $a/\sqrt{3}$ ; and the particles are at distance  $\sqrt{6}a$  apart along the traces of the octahedron planes, though only at distances  $a$  or  $\sqrt{2}a$  across these planes. (In figs. 3b and 3c the section-plane is the same, since it is perpendicular to both the rhombic-dodecahedron and the octahedron, and the particles intersected are also the same; but to avoid confusion in the drawing the two sets of planes are separated in the two figures.) Other section-planes could, of course, be drawn perpendicular to the planes in question, but, whilst the distances between the planes would be the same, the spacing of the particles would be different.

In addition to the simplest type of cubic lattice discussed in some detail above, there are two other types. The three are represented together for comparison in fig. 4. In fig. 4b there is an additional point at the centre of each cube—this may be called the centred cubic lattice; and in fig. 4c there are additional points at the centre of each face, giving the face-centred cubic lattice. The different relations afforded by these types need not be discussed here. But it may be pointed out that in the centred cubic lattice the greatest reticular density is in the rhombic-dodecahedron planes, whilst in the face-centred cubic lattice the particles are most closely packed in the octahedron planes. These would be expected to correspond to cubic crystals showing rhombic-dodecahedral and octahedral cleavage (e.g. zinc-blende and fluor-spar) respectively.

Types of lattices other than the cubic are deduced by varying the distances of the particles along the different axes and by varying the angles between these axes, in a manner similar to that in which the six crystal-systems are deduced. In fact the elements of the elementary cells of the lattice, namely the lengths and inclination of their edges, are identical (except in certain cases) with the parameters  $a:b:c$  and the axial angles  $\alpha, \beta$  and  $\gamma$  deduced from the external crystal faces.

The "particles" referred to above may be crystal molecules, chemical molecules, or even atoms. They are represented in the diagrams as spots without committing ourselves as to their shape or size (in relation to their distance apart). Some authors represent them as spheres in contact with one another, regarding these as the spheres of influence of each atom. If the spheres are of equal size, the number of points of contact and the closeness of the packing will vary with the type of lattice. Or again, we may regard the particles (all of the same size) as completely filling space. In this case the particles in the simple cubic lattice will be cubes, each in contact with six other cubes; in the centred cubic lattice they are cubo-octahedra with 14 surfaces of contact; and in the face-centred cubic lattice they are rhombic-dodecahedra with 12 surfaces of contact.

The above outline of the geometrical structure of crystals has been necessary for the purpose of introducing the new X-ray methods of investigating the internal structure of crystals.

X rays, or Röntgen rays, are propagated as waves in the same manner as rays of ordinary light, but they are of much smaller wave-length. The wave-length of yellow (sodium) light is 0.000589 cm. (i.e. of the order  $10^{-5}$ ), whilst the wave-lengths of X rays are of the order  $10^{-8}$  or  $10^{-7}$  cm., or one thousand to ten thousand times smaller. The very fine rulings of parallel lines (about 7,000 to a cm.) of diffraction gratings being of a magnitude ( $10^{-4}$  cm.) comparable with the wave-lengths of light, they produce well-known diffraction effects. It would be impossible to produce mechanically a grating which would



be fine enough to diffract the much shorter X rays. But it occurred to Dr. Max Laue, of Zurich, that the reticular structure of crystals would supply the necessary grating, since the distances between the atoms in the space-lattices are of the order  $10^{-8}$  cm. When, in 1912, this idea was put to the test a very surprising result was obtained. Plates cut from crystals parallel to certain faces were placed perpendicularly in the path of a thin pencil of X rays, and beyond a photographic plate was exposed. The resulting photograph (known as a Laue photograph or radiogram, Röntgenogram or Röntgen pattern, or spot photograph) shows a larger central spot representing the direct rays, whilst surrounding it is a symmetrical pattern of smaller spots. The spots may also be shown directly by projection on a screen of fluorescent material. This pattern shows the same degree of symmetry as that on the crystal face. Thus a plate from a hexagonal crystal of beryl cut parallel to the basal plane (*i.e.* perpendicular to the principal axis) shows a six-fold arrangement of spots symmetrical about six radial lines at  $30^\circ$ ; whilst when the plate is cut parallel to a prism face of the same crystal the spots are symmetrical about two lines at right angles. Fig. 5 is a reproduction of an actual photograph obtained by passing a pencil of X rays through a basal cleavage plate, 0.81 mm. in thickness, of the pseudorhombohedral chlorite, peminite. This photograph (after H. Haga and F. M. Jaeger, 1915) is selected on account of its comparative simplicity and the obvious three-fold arrangement of the spots.

The results obtained with these Laue photographs were at first explained as due to diffraction, but the problem is much more complex than diffraction by a single system of parallel lines in one plane, since we are here dealing with a lattice in three dimensions in which there are many series of lines in many planes. As explained by Sir William Bragg and his son Prof. W. L. Bragg in their book (*X-rays and Crystal Structure*, London, 1915; 3rd ed., 1918) it is due to the amplification of waves reflected from successive layers of atoms within the crystal. In fig. 6 a beam of X rays  $AB$ ,  $A'B'$ ,  $A''B''$ , all of the same wave-length  $\lambda$ , strikes at a glancing angle  $\theta$  the planes of particles, the distances between which are  $d$  (cf. fig. 3). They are reflected by successive planes as a single ray  $BC$ . Produce  $A'B'$  to  $D$  (then  $BD$  is perpendicular to the planes) and draw  $BN$  perpendicular to  $A'D$ . Then, since  $BB' = B'D$  and  $AB = A'N$ , the length of path of the ray  $A'B'C$  is greater than that of the ray  $ABC$  by the distance  $ND = 2d \sin \theta$ . Similarly,  $A''B''C$  is longer than  $A'B'C$  by the same amount. If, now, this distance is equal to the wave-length of the rays, namely, if  $\lambda = 2d \sin \theta$ , the rays reflected by successive layers of particles will be vibrating in the same phase and their amplitudes will be added together. If the glancing angle  $\theta$  be varied but slightly the reflections from the millions of layers will vary in phase and they will mutually interfere. But at certain other glancing angles  $\theta_1, \theta_2$  when  $2\lambda = 2d \sin \theta_1$  or  $3\lambda = 2d \sin \theta_2$ , there will again be an accumulative effect, giving reflections of the second and third orders. (See fig. 6.)

In the Bragg apparatus, called an X-ray spectrometer, homogeneous ("monochromatic") rays from an X-ray tube emerge through a narrow slit in a leaden screen and strike at a glancing angle the crystal plate mounted on a goniometer. The reflected beam enters an ionization chamber containing sulphur dioxide or methyl bromide and connected with an electro-scope. The crystal is slowly turned on the goniometer until a maximum effect is noted in the electro-scope, when the angle  $\theta$  is read. Plotting the readings of the electro-scope against those of the goniometer, a curve ("X-ray spectrum") is obtained which shows a series of sharply defined maxima or peaks corresponding to reflections of the first, second, and other orders. Knowing the wave-length of the rays, the distance between the planes of particles can then be calculated from the above fundamental equation; or alternatively, knowing the spacing of the planes, the wave-length of the rays can be determined. As an example, rays from a palladium anticathode ("palladium rays") were strongly reflected from the cube face of rock-salt when the angle  $\theta$  was  $5.9^\circ$ ,  $11.85^\circ$ , and  $18.15^\circ$ . Taking the spacing  $d$  between the cube planes of rock-salt as  $2.81 \times 10^{-8}$  cm., the wave-length  $\lambda$  is found to be  $2 \times 2.81 \times 10^{-8} \sin 5.9^\circ = 0.578 \times 10^{-8}$  cm., or  $2 \times 2.81 \times 10^{-8} \sin 11.85^\circ = 1.154 \times 10^{-8}$  cm.

To return now to an explanation of the spots shown by the Laue photograph. Here, instead of homogeneous rays, the rays employed are of mixed wave-lengths (as in white light). For each a bundle of rays reflected by a certain set of parallel planes (as explained in fig. 6) there will be some wave-length that will satisfy the equation  $\lambda = 2d \sin \theta$ , or in other words  $\lambda = 2d \sin \theta_1$ . There will then be a reinforcement in the reflection of these rays from the particular set of planes. Let fig. 7 represent a plate of beryl cut perpendicular to the principal axis of the crystal; the upper and lower boundaries in the figure being then parallel to the basal plane. The rows of particles lie in the traces of two sets of planes respectively parallel to

two possible pyramidal faces of the crystal. Reflection from these will yield two spots on the photographic plate. Now, according to the hexagonal degree of symmetry possessed by beryl, there will be 6 (or 12) similar sets of planes equally inclined to the vertical axis, and corresponding to a hexagonal (or dihedral) pyramid; consequently 6 (or 12) similar spots will appear on the photograph equally distant from the centre. For other sets of 6 (or 12) planes inclined at other angles to the vertical axis of the crystal, and parallel to possible faces of hexagonal or dihedral pyramids, intensified reflections will take place for rays of other wave-lengths. The result will be a large number of spots on the photographic plate, but all of them in sets of 6 (or 12) symmetrically grouped around the centre.

Some of these Laue photographs are highly complex in appearance, but by analysis they can be reduced to simple crystallographic relations. Since each spot represents a structural plane in the crystal and also a possible external crystal-face, the series of spots lie in zones and their Millerian indices can be deduced. Further, it will be seen from fig. 7 that the distances of the spots from the centre are in direct relation to the inclinations of the various planes. Fig. 8 (after H. Haga and F. M. Jaeger, 1915) shows plotted on a stereographic projection the series of spots of a Laue photograph on the face (101) of anhydrite. The spots are in a symmetrical grid with respect to two lines at right angles, corresponding to the orthorhombic symmetry of the crystal. The zone-circles are drawn a one-half of the diagram and the indices of the planes are given a one-quarter. It is thus possible to deduce from the Laue photographs not only the zonal relations and indices of possible faces (many of which have not been observed as actual faces), but also the angles between these faces and the fundamental elements of the crystal. This information can even be obtained from an irregular fragment showing no external faces and of unknown orientation. Such a fragment is mounted on a two-circle goniometer and a series of Laue photographs taken in various positions; and a special instrument is provided for the analysis of the series of photographs.

A further point to be noticed in the Laue photographs (figs. 5 and 8) is that the spots are of different sizes and intensities (sharp spots repeated by the symmetry are, of course, identical). The stronger reflections are from planes of greater reticular density and indicate at once the important structural planes and the prominent faces of the crystal.

A third method of investigation has been devised by P. Debye and S. Scherrer in Germany in 1916, and independently by A. W. Hull in the United States in 1917. Here a beam of homogeneous ("monochromatic") X rays of known wave-length is transmitted through the finely powdered crystalline material, and the reflections received on a photographic film. The tiny crystal fragments are in all manner of orientations; and to further ensure all possible orientations in the aggregate, the tube containing the small amount of powder is rotated during the exposure. For structural planes with the spacing  $d$  there are bound to be some of the particles in the position shown in fig. 6 in which the equation  $\lambda = 2d \sin \theta$  is satisfied; but these will be lying in all azimuths, *i.e.* sloping away in all directions at the angle  $\theta$  from the axis of the rays. The reflected rays will consequently lie on the surface of a cone, the angle of which is  $2\theta$ ; and, instead of a single spot, a continuous series of spots forming a circle will appear in the photograph. Similarly, in other fragments the same set of planes with spacing  $d$  may be inclined at angle  $\theta_2$  giving a second order reflection as required by the equation  $2\lambda = 2d \sin \theta_2$ , and producing a wider-angled cone concentric with the first. Further, other structural planes with spacing  $d_1$  and inclined at other values of  $\theta$  will be provided by other fragments, giving still other circular reflections. Since, however, the experiment is performed with rays of one wave-length, it is only certain values of  $d$  that will satisfy the equation, so that the number of reflections is really limited. Even with this limited number, there would appear to be some difficulty in sorting-out the reflections of the different orders and those from different structural planes. Since it is only the angles of divergence of the concentric circular sheaths that are to be measured, all that need be photographed is a narrow strip through the centre. This strip is made semicircular, in order to embrace a wide field of reflected cones. Knowing  $\theta$  and  $\lambda$ , the equation gives, as in the Bragg method, the spacing  $d$  between the structural planes of the crystal.

Although the Debye-Scherrer method may be regarded as a modification of the Laue method, yet the results it gives are the same as those given by the Bragg method, namely the spacing between the structural planes of the crystal. The Laue method gives other supplementary information, but it is mainly on the spacing between the planes of particles that ideas of structure are built up. A large amount of experimental work on crystals of different substances has been done in this direction, and indications have been drawn as to their probable atomic arrangement. In this place only one or two examples can be briefly considered.

Rock-salt (sodium chloride) crystallizes in cubes and possesses a perfect cleavage parallel to the faces of the cube. Plates cut parallel to the faces of the cube (100), the rhombic-dodecahedron (110), and the octahedron (111) respectively give by the Bragg method values for the spacing between the planes of particles in the ratio of  $1 : 1/\sqrt{2} : 1/\sqrt{3}$ . These ratios are the same as those mentioned above for the simple cubic space-lattice (figs. 1-3), and the conclusion

# CRYSTALLOGRAPHY

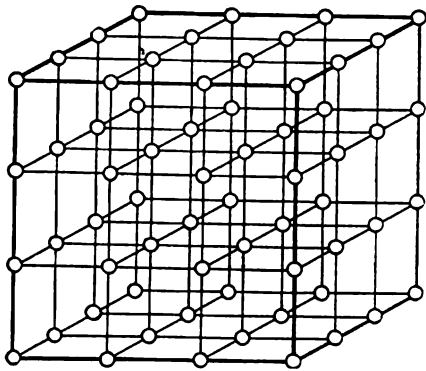

FIG. 1.—Simple Cubic Space Lattice.

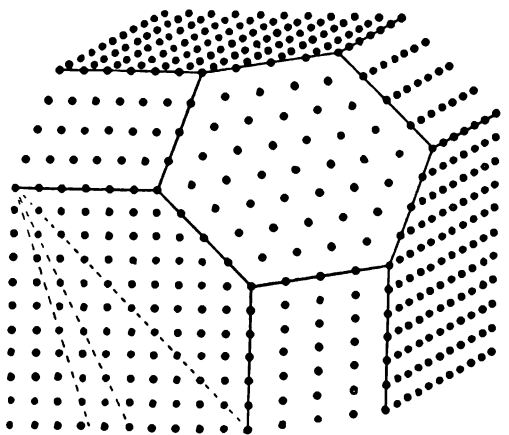

FIG. 2.—Arrangement of Points on the Surface of a Cubic Crystal. (Simple cubic lattice.)

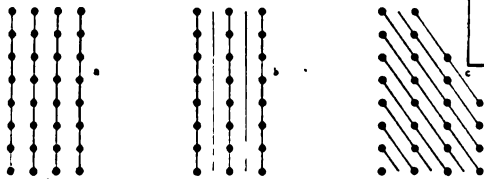

FIG. 3.—Vertical Sections Through the Structure (fig. 2), showing:—  
(a) Distance between cube planes.  
(b) Distance between rhombic dodecahedron planes.  
(c) Distance between octahedron planes.

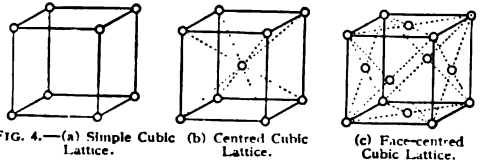

FIG. 4.—(a) Simple Cubic (b) Centred Cubic (c) Face-centred Cubic Lattice.

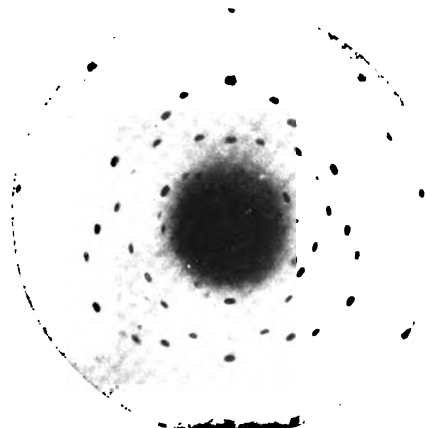

FIG. 5.—Laue X-ray Photograph Through the Basal Plane of Penninite.

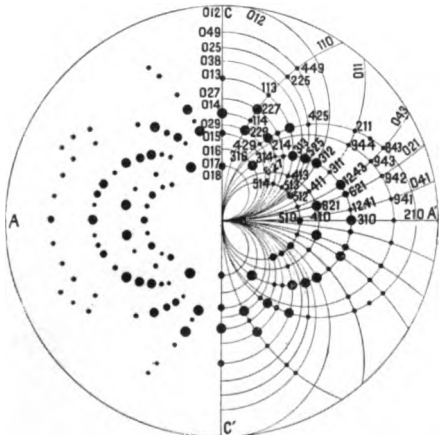

FIG. 8.—Stereogram of Laue Photograph of Anhydrite on the Face (100).

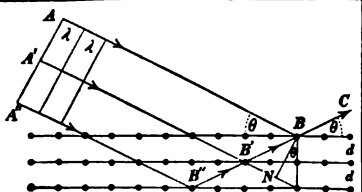

FIG. 6.—Reflection of X Rays by Planes of Particles.

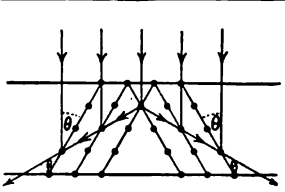

FIG. 7.—Reflection of X Rays by Planes of Particles: production of spots in the Laue photographs.

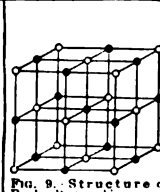

FIG. 9. Structure of Rocksalt (sodium and chlorine atoms in simple cubic space-lattice); or all of the same kind, or Zinc-blende when of two kinds.

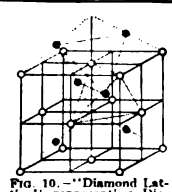

FIG. 10.—"Diamond Lattice" representing Diamond when the atoms are cubic space-lattice; or all of the same kind, or Zinc-blende when of two kinds.



may be drawn that this represents the structure of rock-salt. The two kinds of atoms, sodium and chlorine, may be placed alternately along the three directions, as shown in fig. 9. As so represented the structure may also be regarded as an interpenetration of two space-lattices of the face-centred cubic type (fig. 4c), with the sodium atoms on one lattice and the chlorine atoms on the other. One lattice can be brought into the position occupied by the other by a parallel shift along a cube edge through the distance between two consecutive planes. The actual distance between the cube planes, and consequently also between the atomic centres, has been determined to be  $2.81 \times 10^{-8}$  cm., or rather more than a hundred-millionth of an inch. In the drawings, the scale of the lattice is enormously enlarged and only an infinitesimal portion of the crystal is represented. Some idea of this may be conveyed by saying that if we took a cubic inch of rock-salt and represented the whole of the structure on the same scale as in fig. 9 the drawing would be rather more than a thousand miles across. The same structure is also shown by galena (lead sulphide, PbS), the crystals of which also possess a perfect cubic cleavage: the two kinds of atoms shown in fig. 9 here represent lead and sulphur. Other examples are potassium chloride, potassium bromide, etc.

Examples of crystals with the structure of the centred cubic lattice (fig. 4b) are those of the metals iron, sodium, tungsten, etc. The face-centred cubic lattice (fig. 4c) is represented by crystals of the metals copper, silver, gold, platinum, etc.

A special type of cubic lattice, known as the "diamond lattice," consists of another kind of interpenetration of two face-centred lattices. In fig. 10, to avoid confusion, only one such lattice is represented in detail—the white particles clearly having positions shown in fig. 4c. Four black particles belonging to the other lattice are placed each at a centre of alternate sub-cubes in the first lattice. Through the whole structure there are, of course, equal numbers of the white and black particles. The positions of two more black particles are indicated in the next storey above of the white-particle lattice. Now it will be seen that around each black particle there is a tetrahedral arrangement of four white particles, and around each white particle a tetrahedral arrangement of four black particles (but, conversely, it is only alternate tetrahedral groups of each kind that have a particle of the other kind at their centre). The front outlines of two of these tetrahedra are indicated in the figure. The upper tetrahedron of four black particles has at its centre the white particle in the centre of the top cube face; and one of these same black particles is at the centre of the tetrahedron of white particles at alternate corners of the upper, front, right-hand sub-cube. The first tetrahedron can be brought into coincident position with the second by sliding it downwards and forwards along one-quarter of the diagonal of the cube, and then rotating it through  $90^\circ$  about a cube edge. The same is also true of the whole lattice; i.e. one lattice can be brought into exactly the position of the other by these two successive operations. The symmetry of the whole model is that of the tetrahedral class of the cubic system; but, in addition, the two sets of particles are directed towards different directions. Regarding the particles as spheres of equal size and in contact with one another, then each one is touched by only four others, the latter with a tetrahedral arrangement; much of the space is thus vacant, and more space of the same size could be dropped into the large interspaces. Or again, if the particles (all of the same size) entirely fill a space, they will have the form of regular tetrahedra the four corners of which are each replaced by three faces of the rhombic-dodecahedron (much as in fig. 33, vol. 7, p. 575, but with the faces of the tetrahedron cut off to regular hexagons).

This type of structure is shown by diamond, silicon, grey tin, and zinc-blende, and also by copper-pyrites (a tetragonal mineral, but with very nearly cubic angles). In the first three, being chemical elements, the atoms on the two lattices are of the same kind. In diamond each carbon atom is surrounded tetrahedrally by four others at a distance, between the centres, of  $1.53 \times 10^{-8}$  cm. In zinc-blende (ZnS) the zinc atoms lie on one lattice, whilst the sulphur atoms lie on the other. Since the two lattices are identical and superposable, it is immaterial whether the black particles represent sulphur or zinc atoms. In copper-pyrites (CuFeS<sub>2</sub>) the sulphur atoms are said to lie on one lattice and the copper and iron on the other; the copper and iron atoms being in alternate horizontal layers perpendicular to the principal axis of the crystal. It is, however, to be remarked that these three minerals, to which the same type of structure is ascribed, exhibit marked differences in their cleavages. Diamond has a perfect octahedral cleavage, zinc-blende a perfect rhombic-dodecahedral cleavage, whilst copper-pyrites has none. Again, the high density and the extreme hardness of diamond would seem to suggest that there should be less unoccupied space in the structure.

A fuller account is given in Bragg's book quoted above. A series of excellent summaries of this and other matters relating to chemical crystallography are given by T. V. Barker in the *Annual Reports of Progress of the Chemical Society* (London, 1913 et seq.). In the latter will also be found the best available account of the extraordinary work of the Russian crystallographer, E. S. Fedorov, who perished in Petrograd in 1919.

REFERENCES.—A comprehensive and general treatise is A. E. H. Tutton's *Crystallography and Practical Crystal Measurements* (London

1911; 2nd ed. 1921). A popular work of the same author is *Crystals* (International Scientific Series, London 1911). Structure theories are discussed by P. Niggli, *Geometrische Kristallographie des Diskontinuums* (Berlin 1918); F. M. Jaeger, *Lectures on the Principles of Symmetry* (Amsterdam 1917; 2nd ed. 1920); J. Beckenkamp, *Statische und kinetische Kristalltheorien* (Berlin 1915); see also Bragg and Barker quoted above. Elementary text-books are: T. L. Walker, *Crystallography, an Outline of the Geometrical Properties of Crystals* (New York 1914) in which the subject is treated from the point of view of two-circle goniometry; Sir Wm. P. Beale, *An Amateur's Introduction to Crystallography from Morphological Observations* (London 1915); P. Groth, *Elemente der physikalischen und chemischen Kristallographie* (Munich 1921); J. Beckenkamp, *Leitfaden der Kristallographie* (Berlin 1919). A collection of thousands of drawings of crystals with critical lists of forms is given by V. Goldschmidt, *Atlas der Kristallographie* (several 4to vols., in progress, Heidelberg 1913, etc.). New crystal-forms together with other crystallographic constants are listed in the international *Tables annuelles de constantes et données numériques* (4 vols., Paris 1912, etc.). An historical sketch of the early development of crystallography is given by Hélène Metzger, *La genèse de la science des cristaux* (Paris 1918). (L. J. S.)

**CSAKY, ALBIN, COUNT** (1841–1912), Hungarian statesman, was born on April 18 1841 at Kropfisch, in the county of Szepes, and studied law at Kassa (Kaschau) and Budapest. Deputy in 1865, he was from 1868 to 1886 *Obergespan* (lord-lieutenant), in which capacity he gained the reputation of an excellent administrator. In 1884 he pleaded eloquently in the House of Magnates for the establishment of civil marriage, and in 1888 was Minister of Education in the Cabinet of Koloman Tisza. Together with Szilagyi, the Minister of Justice, Csaky was one of the most decided champions of obligatory civil marriage and of the rights of the Jews. He resigned in 1894, and in 1900 was appointed president of the House of Magnates, an office which he resigned on the fall of the Liberal party in 1906. Under the Khuen-Hedvary Government he became on June 18 1910 once more president of the House of Magnates.

**CUBA** (see 7, 594\*).—From 1909, when for the second time the management of Cuban affairs was turned over by the United States to the Cuban Government, until the end of 1920, there was a steady growth in Cuba's prosperity. This growth was greatly accelerated during the first half of the year last mentioned, but suffered a serious reverse toward the end of the year. The census of 1910 showed a pop. of 2,868,905 (1907, 2,048,980), an average of 65.56 per sq. mile. The total immigration was in 1914, 24,420; in 1918, 37,320; and in 1919, 80,485. Of immigrants in 1919, 39,573 were from Spain. The immigrants from Jamaica, who numbered only 995 in 1914 and 9,184 in 1918, increased to 24,187 in 1919. It is stated that probably 75% of the immigrants return to the country of origin within the course of a year, coming to Cuba only for the high wages paid during the cane cutting and grinding season.

*The Sugar Industry.*—Sugar is the basis of Cuba's prosperity. The climate and fertile soil are admirably adapted to the growth of sugar cane, and the island has come to be recognized as the "sugar bowl of the world." The high prices that prevailed in 1919–20 enabled the sugar industry to put more of the soil under cane than ever before and to construct many of the most modern and efficient sugar mills in the world. The sugar crop, which in 1910–1 totalled 1,379,609 long tons, steadily increased, except for a slight decline in 1914–5. In 1918–9 the production reached 3,720,000 tons or 61% of the total cane sugar produced by the western hemisphere; 34% of the world's cane sugar production, and 25% of the world's total sugar production, as against an average of 11% in the decade preceding the World War. Production increased more than 50% during the five years 1913–4 to 1918–9. During the period 1909–14, approximately 95% of Cuba's crop went to the United States (almost half of that country's supply), the remaining 5% being used for home consumption. In 1917–8 the entire crop, except that used for home consumption, was purchased by the United States and the Allies, two-thirds for the former, one-third for the latter. The 1918–9 crop was similarly contracted for, but part of the share of the United States was later diverted to other countries. The crop for 1919–20 was 3,730,077 tons. The price, which had been from two to three cents a pound before the war, advanced slowly but steadily during the war. The crop for 1917–8 was sold to the United States at 4–6 cents l. o. b. Cuban ports, and that for 1918–9 at 5½ cents. But the next year the world's shortage (nearly 2,000,000 tons compared with 1913–4), the increased consumption in the United States and the failure of the latter to purchase the 1919–20 crop, although it was offered and could probably have been obtained at about 6½ cents a pound, caused a keen competition for the Cuban supplies.

\* These figures indicate the volume and page number of the previous article.

opened the way for wild speculation and led to an unprecedented rise in price. In the early part of the year the price was about 11 cents a pound, but rose rapidly until a peak of 22½ cents was reached in May, when the market broke. Thereafter, the price declined almost as rapidly as it had risen, reaching at the end of Nov. about 3½ cents, near which it continued for several months. To prevent a further decline and, if possible, force an upward reaction, a price-fixing commission was in Feb. 1921 appointed by the president of Cuba and given power to control the sale and exportation of the entire 1920-1 crop.

**Other Industries.**—Of the island's agricultural products, tobacco ranks next to sugar in importance, the total value of the crop ranging from 40 to 50 million dollars per annum. A high import duty recently placed upon coffee had the effect of stimulating that industry, but the production in 1919 was still far below the requirements of the population. The culture of henequen or "sisal" promised to become important, as did also the production of jute. Cotton was being cultivated experimentally. The cultivation of fruit and vegetables for winter consumption in the United States was quite an extensive industry, the soil and climate lending themselves easily to the production of citrus fruits, bananas, pineapples, coconuts and various garden vegetables. Cuba produced an appreciable portion of the world's supply of sponges. (The average output of Batabanó, where 25% of the male population were engaged in this industry, is said to approximate half a million dollars a year. There was a considerable and growing interest in the cattle industry, and hides and skins were exported in increasing quantities. In 1911 a commission was sent to the United States to purchase thoroughbred stock for breeding purposes at the six Government experiment stations. There were, in 1919, about 4,000,000 head of cattle, 780,000 horses, and 64,570 mules. The manufacture of turpentine was a new industry, begun after an investigation of pine trees in the Isle of Pines. Of mineral products, iron continued to be the most important, though mines of manganese, copper and asphalt were important. The iron deposits in the province of Oriente near Santiago de Cuba, in spite of active mining since 1908, can be said to be hardly touched. The iron mines in this district employed over 4,000 workmen and supplied an average of 50,000 tons of ore per month to the United States. Exploitation for petroleum has been going on for several years, but no proof has been found of oil deposits of commercial importance.

**Commerce.**—Cuba is an intensely commercial country, exporting most of what she produces and importing nearly everything that she consumes. Metals and manufactures thereof constitute about 7% of her total imports; drugs and chemicals 7%; textiles and manufactures 13%; paper 2%; wood and manufactures 3%; animals and their products 5%; machinery and instruments 12 to 13% and foods 35 to 40%; the balance being made up of miscellaneous articles. Of exports, sugar constitutes about 85%, tobacco 8 to 10%, fruits about 2%, minerals and ores 3%. During the fiscal year 1913-14, the last normal year before the war, the total commerce of the island was valued at \$304,805,000, with imports valued at \$134,008,000 and exports \$170,797,000, imports from the United States representing 53.2% and exports to the United States 80% of the total. Sugar represented 70% and tobacco 20% of the exports, whereas from 1904-7 they had represented 60.3 and 27.3% respectively. Cuba enjoys a preferential duty of 20% on exports to the United States and grants reciprocal concessions of 20 to 40% on all merchandise imported from the United States. This accounts for the dominant position of the United States. During the fiscal years 1912-3 to 1915-6, the United States received on an average 80.6% of the total exports from Cuba. For the years 1916-7 and 1917-8 the average was 71.86%, this reduction in percentage being due to shipments of sugar to the Allies in Europe where production of beet sugar had been lowered by the war. Cuba's international trade for the fiscal year 1918-9 was \$794,000,000, exports totalling \$477,000,000 and imports \$316,000,000.

The United States supplied 74.5% of the imports and received 73.2% of the exports. The item of greatest value was foodstuffs worth \$115,000,000. Exports of sugar and its products amounted to \$409,629,000, representing 85.6% of the total, while exports of tobacco and its products amounted to \$40,837,000, or 8.1% of the total exports. Cuba's total foreign trade during the fiscal year 1919-20 amounted to \$480 per capita, about four times as much as that of the United States during 1920 and probably more than that of any other country for any year. During 1920 the trade of the United States with Cuba was greater than the combined trade with the three next most important Latin-American customers—Argentina, Brazil, and Mexico; and United States trade with Cuba for the same year was only slightly (a little under 10%) less than with all South America. The total value of imports from the United States in 1918-9 was \$235,727,000, compared with \$228,102,000 in 1917-8. Imports from Great Britain in 1918-9 amounted to \$9,349,000; from Spain \$13,332,000; from France \$8,265,000 compared with \$12,508,000, \$11,695,000 and \$6,875,000 respectively in 1917-8. Exports from Cuba to the United States in 1918-9 were \$350,316,000; to Great Britain \$96,814,000; to Spain \$6,057,000; to France \$11,324,000. Exports to these countries in 1917-8 were \$278,704,000, \$76,722,000, \$4,199,000 and \$8,965,000 respectively. During the calendar year 1919, imports from the United States amounted

to \$278,371,222, and exports to United States \$418,610,263. For the calendar year 1920, imports from the United States amounted to \$515,082,549 and exports to the United States \$721,695,905. Thus, the total trade between the United States and Cuba was almost twice as great in 1920 as for the fiscal year 1918-9.

**Port Congestion.**—When, early in 1920, fabulous prices for sugar prevailed, and all kinds of merchandise sold readily at high prices, goods were ordered abroad more rapidly than they could be cleared through the customs house. This condition grew steadily worse until near the end of the year when, after the appointment of a special supervisor charged with the duty of clearing the ports, recommendations made by a joint Cuban-American Port Congestion Commission which had sat at Havana in Aug. were put into operation. Thereafter, improvement though slow was steady. The situation was aggravated by the desire of many importers to cancel their orders for high-priced merchandise when the general decline in prices held out a prospect of obtaining cheaper goods. In the case of rice, the concerted efforts at cancellation became so general that the Government placed a temporary embargo on further importations of rice except on special licence. The port congestion and the cancellation movement were both intensified by the declaration of a moratorium in October.

**Communications.**—Cuba had in 1920 four principal railway systems which together extended their lines from one end of the island to the other, namely, the United Railways of Havana, the Cuba Railroad, the Cuban Central Railways, and the Western Railway of Havana. These systems, together with the private lines connecting the larger sugar estates with them, constituted 3,200 m. of railway in 1919 as against 2,329.8 m. in 1908. Considerable attention has been paid in recent years to the construction of good roads, and large sums of money have been voted. In 1919 there were said to be over 1,400 m. of splendid roads for automobiles. A car ferry service between Key West and Havana inaugurated in 1915 greatly facilitated the movement of freight between Cuba and the United States. Direct steamship connexion existed with many of the ports of the United States as well as with Europe and Mexico. Frequent service was maintained to New York, Boston, Philadelphia, Galveston, New Orleans, Mobile, Tampa and Key West, and in 1920 regular passenger and freight service was inaugurated by the Miami Steamship Co. between Jacksonville, Fla., and Havana, with sailings every five days. Air mail service was started late in 1920 between Key West and Havana with two seaplanes, each having a capacity of 1,000 lb. of mail, 12 passengers and 400 lb. of luggage.

**Education.**—Educational affairs were given increasing attention after 1908. Considerable sums of money were appropriated and many new schools established, among them normal schools in the several provinces, numerous day schools, several night schools, and agricultural experiment schools in Havana. A national military academy was established in 1912. A bill was passed in 1916 granting to rural public-school teachers an increase in salaries aggregating more than \$1,000,000 per year. This raised individual salaries of \$45 and \$50 per month to \$75 and \$80. On Nov. 30 1919 there were 5,877 teachers and 334,641 pupils in the elementary schools. In "Institutes of Secondary Instruction" there were 2,087 students in 1915-6. The university of Havana was said to have, in 1919, nearly 1,600 students.

**Finance.**—Until recent years Cuba had no money of its own issue, mainly Spanish gold and various other foreign coins having been the medium of exchange; but in 1915, by virtue of an Act passed during the preceding year, a new coinage was put into operation. The monetary unit is the gold peso of the same weight and fineness as the American dollar. Gold coins, of which the issue is unlimited, are 1, 2, 4, 5, 10 and 20 peso pieces, the last three of the same shape, weight and value as corresponding U.S. coins, and the other proportionate; silver coins, of which the issue is limited to 12,000,000 pesos, are 10, 20 and 40 centavo pieces and the peso; nickel coins, limited by executive discretion only, are 1, 2 and 5 centavo pieces. United States coins and paper currency are also legal tender, but not those of other foreign countries unless such payments are specifically contracted for. The revenues of the Government, which in 1912, amounted to about 37.9 million dollars, rose to 64.5 millions in 1918-9, and 79 millions in 1919-20. More than half of the revenue is derived from customs duties. Cuba had in 1920 a foreign debt of about \$51,000,000, floated through banking houses in the United States, also a domestic debt of about \$39,000,000.

**The Moratorium.**—The enormous profits derived from the sale of high-priced sugar during the first half of 1920, instead of being conserved in the form of liquid assets were invested in enlarging the facilities for producing and grinding sugar, in building fine homes and in purchasing luxuries. When, about midsummer, the price of sugar began to decline, an effort was made to check the tendency by refraining from selling the remaining portions of the preceding crop. To continue operations and prepare for harvesting the new crop, large amounts of money were borrowed from the banks, the unsold sugar being pledged as security on what was at the time regarded as a safe basis of 15 or 16 cents per pound. The experiment was unsuccessful. The rapid decline soon carried prices far below the point at which the banks had accepted the sugar as security. Thereupon, it ceased to be an asset and became a liability. Early in Oct. there occurred a run on one of the largest banking institu-

tions in Havana, which had many branches throughout the island; in order to prevent the collapse of this bank, and the extension of the panic to others, a moratorium was declared on Oct. 10 to last for 50 days. On Dec. 1 it was extended until Dec. 31, and again until the end of Jan. 1921. Just before the last date, a Congressional Act provided for the gradual lifting of the moratorium, requiring partial payments running through 105 days for ordinary commercial obligations, and 135 days for banking obligations. A law was simultaneously promulgated providing for the liquidation of insolvent banks under Government supervision; and provision was also made for a reform in banking laws with a view to preventing a recurrence of such a condition.

**Political Conditions.**—The administration of President José Miguel Gómez and Vice-President Alfredo Zayas of the Liberal party continued from Jan. 28 1909 (at which time the administration of the American Provisional Government ceased) until May 20 1913. During this period there were internal troubles which threatened to assume a revolutionary character. A serious revolt of negroes in May 1912 was followed shortly afterwards by the concentration of a U.S. fleet of battleships at Key West. President Taft assured the Cuban Government that this was not due to a purpose of intervention, but to a desire to act promptly in case it became necessary to protect American life and property. By the middle of the summer the rebellion was suppressed. On Nov. 1 1912, Gen. Mario G. Menocal and Enrique José Varona, Conservative candidates, were elected president and vice-president, respectively, and were inaugurated on May 20 1913. The administration proved to be efficient. The Government's progressive policy was evidenced by the attention given to educational affairs, by the enactment of comprehensive health laws and by large expenditures for the development of the resources of the country and for public works. During 1915 there was considerable political activity looking toward the elections of Nov. 1 1916, the Conservatives supporting Menocal for reelection while the Liberals, under the leadership of Alfredo Zayas, a former vice-president under Gómez, were trying to secure control. Menocal's reelection was declared Nov. 3, but was contested, and not until May 7 1917 was it finally proclaimed by the Cuban Congress. This contesting of the election occasioned a revolt by the Liberals under the leadership of ex-President Gómez, which assumed serious proportions; but by May 20 the revolt had subsided and Gen. Menocal took the oath of office for a second term. On April 7 1917, Cuba declared war on Germany. The president of the republic was authorized to dispose of the land and naval forces and the economic resources of the nation in whatever manner necessity required. Several revenue measures were announced, including normal and extraordinary war taxes on sugar, and taxes on net profits of mining and insurance companies. A bond issue of \$23,000,000 was authorized for a war loan beginning July 1. In 1918 an obligatory military service law was put in force and a Food Administration with extensive powers was established. Diplomatic relations with Germany were renewed on Oct. 27 1920. A new electoral law was passed in Aug. 1919. This new code was compiled with the assistance of Maj.-Gen. Enoch H. Crowder of the U.S. army. It was he who, while serving with the American army of occupation in Cuba, had formulated the existing laws and had supervised the first presidential election. The new law provided for recognition of all political parties and for public counting of ballots. This new law was put to the test on Nov. 1 1920, which marked the end of the most bitter political campaign since Cuban independence. José Miguel Gómez (1896-1921) was the Liberal candidate, and Dr. Alfredo Zayas was the candidate of the National League or Coalition party, the latter having broken away from the Liberal party and, backed by the Menocal administration, parted company with Gómez. The result of the election was doubtful. Charges of unfair practices made investigations necessary. Incorrect interpretations placed upon the new election laws brought about a complete deadlock. Early in Jan. 1921 Gen. Crowder was sent to Cuba as the personal representative of President Wilson. As a result of his interpretation, means were found for facilitating the procedure of the courts in the contested election cases, and supplementary elections were held in March.

(W. R. MA.)

**CUMMINGS, WILLIAM HAYMAN** (1831-1915), English musician, was born at Sidbury, Devon, Aug. 22 1831, the eldest son of Edward Manley Cummings. He became a chorister at St. Paul's cathedral and the Temple church, and was subsequently appointed organist of Waltham Abbey. Later he was appointed tenor at Westminster Abbey, the Temple church and the chapels royal, being well known for many years as an oratorio singer. From 1879 to 1896 he was professor of singing at the Royal Academy of Music, and from 1896 to 1920 principal of the Guildhall School of Music. In 1900 he received the degree of Mus. Doc. from Dublin University. Cummings was the author of many works on music, including *Lines of Purcell* (1881) and *Handel* (1904), and *The Origin and History of "God Save the King"* (1902). He was also an authority on ancient music, and left a fine collection of old MSS. and early editions. He died at Dulwich June 6 1915.

**CUMMINGS, ALBERT BAIRD** (1850- ), American politician, was born at Carmichaels, Pa., Feb. 15 1850. After leaving Waynesburg (Pa.) College he studied surveying and became assistant chief engineer for a railway. He next studied law, was admitted to the bar in 1875, and for three years practiced in Chicago. In 1878 he went to Des Moines and ten years later was a member of the Iowa House of Representatives. He was chairman of the Republican State Committee (1892, 1896), candidate for the U.S. Senate (1894, 1900), member of the Republican National Committee (1896, 1900), and a delegate to the Republican National Convention on four occasions. He was elected governor of Iowa in 1902 and reelected for two succeeding terms. He filled the unexpired term of Senator Allison in 1908, and was reelected to the U.S. Senate in 1909 and 1915. He opposed the nomination of Mr. Taft in 1912, but did not bolt his party. He was specially identified with measures concerning trusts and railways, and had a leading part in drafting the so-called Esch-Cummings bill under which the Government in 1920 handed back to private control the railways of the United States.

**CUNLIFFE, WALTER, 1ST BARON** (1855-1920), English banker, was born in London Dec. 4 1855, the son of Roger Cunliffe, a banker of the City of London. He was educated at Harrow and Trinity College, Cambridge, and entered upon his banking career in the City in 1880, establishing ten years later the merchant banking business of Cunliffe Bros. He became a director of the Bank of England in 1895, was elected deputy-governor in 1911 and governor in 1913. He was, therefore, in office as governor when the World War broke out, and, after being raised to the peerage with the title of Baron Cunliffe of Headley in Dec. 1914, he was continued as such by successive re-elections until 1918, a longer period than had ever been served before. During the whole of this period the deputy-governor was Mr. Brien Cokayne, who was knighted in 1917, and who, after succeeding Lord Cunliffe as governor, was created Lord Cullen of Aeshbourne on his retirement in 1920. Lord Cunliffe was associated with the working out of all the chief financial problems during the war, and in 1917 accompanied Mr. Balfour on his financial mission to the United States. He died suddenly at Epsom Jan. 6 1920.

**CUNNINGHAM, WILLIAM** (1849-1919), English economist (see 7.633), died at Cambridge June 10 1919.

**CUNNINGHAME-GRAHAM, ROBERT BONTINE** (1852- ), British author and traveller, was born in 1852, the son of William Cunninghame-Graham Bontine of Ardoch and Gartmore, and was educated at Harrow. He sat in the House of Commons for North Lanarkshire from 1886 to 1892, and during this period became known as an extreme Socialist, taking part with H. M. Hyndman and others in Socialist meetings and processions in London to demand work for the unemployed. He travelled much in North Africa, Mexico and South America, and wrote a number of short stories and vivid studies of life in those regions. Among his books may be mentioned *Mogreb-el-Akhsar: a Journey in Morocco* (1898); *The Ipana* (1899); *A Vanished Arcadia* (1901); *Faith* (1909); *Hope* (1910); *Charity* (1912); *A Life of Bernal Diaz del Castillo* (1915); *A Brazilian*



*Mystic* (1920); *Carliaga and the Book of the Firm* (1920). Early in the World War he went to South America to buy horses for the British army, and carried out his mission with success.

**CURRIE, SIR ARTHUR** (1875- ), Canadian general and administrator, was born at Napperton, Ont., Dec. 5 1875. On the outbreak of the World War his natural bent for military affairs quickly brought him to the front. He commanded the 1st Canadian Div. 1914-7, and the Canadian Corps in France 1917-9. He gained the confidence of the English military authorities in the field, and when Lord Byng resigned his command of the Canadian troops Sir Arthur Currie was the one Canadian to whom it was felt by the British Headquarters that the command could be entrusted. The manner in which he carried out his command marked him by common consent a military leader of unusual distinction. In the concluding phases of the war the Canadian forces under his command played a notable part. Currie was given the C.B. in 1915, K.C.M.G. 1917, K.C.B. 1918 and G.C.M.G. 1919; he was awarded the French Legion of Honour and the Croix de Guerre both of France and of Belgium, and was created Grand Officer of the Belgian Ordre de la Couronne. In 1920, after Sir Auckland Geddes had finally declined the nomination to the principality of McGill University, Montreal, on his appointment as British ambassador to Washington, Sir Arthur Currie was elected to the post.

**CURTIS, CYRUS HERMANN KOTZSCHMAR** (1850- ), American publisher, was born at Portland, Me., June 18 1850. He was educated in the public schools of Portland, sold newspapers when a boy, and in 1870 joined a Boston paper as advertising solicitor. In 1876 he went to Philadelphia and became a publisher of the *Tribune and Farmer*, a weekly paper. In 1883 he established the *Ladies' Home Journal*, and in 1891 organized the Curtis Publishing Company. In 1897 he purchased the *Saturday Evening Post*, which was a direct continuation of the *Pennsylvania Gazette*, founded in 1728 by Benjamin Franklin, and in 1911 he bought the *Country Gentleman*. The *Ladies' Home Journal* and the *Saturday Evening Post* attained a circulation of 2,000,000 each, and probably carried more paid advertising than any other publications in the world. For this reason, although the cost of producing a copy of the *Saturday Evening Post* was many times its selling price to the public (5 cents), this magazine was highly profitable to the publisher. In 1913 he purchased the *Philadelphia Public Ledger*.

**GURZON OF KEDLESTON, GEORGE NATHANIEL CURZON, 1ST MARQUESS** (1859- ), English statesman (see 7.663), received an earldom (along with the viscountcy of Scarsdale and the barony of Ravensdale) as one of the coronation honours in 1911. He was conspicuous in that year first by his strong denunciation of the Parliament bill and the whole Liberal attack on the Lords, and then by the leading share which he took, in the final stage, in persuading the bulk of the Unionist peers to abstain from voting in the crucial division and so to permit the bill to pass rather than have their House swamped by hundreds of creations *ad hoc*. During the vehement party conflicts of the next two or three years before the World War he established his position as the chief lieutenant of Lord Lansdowne in the Lords. But much of his time and attention during the period of opposition were given to the affairs of Oxford University, of which he had become chancellor; and he promoted the cause of reform there by personal effort and by publishing a detailed memorandum on the subject. With other Unionist leaders he joined Mr. Asquith's Coalition Cabinet in the summer of 1915, as Lord Privy Seal; and in that capacity he introduced the bill constituting the new Ministry of Munitions under Mr. Lloyd George, and took charge in the Lords of the Munitions of War bill which was to furnish that Ministry with its weapons. In these and other ways he gave proof of a determination to prosecute the war with zeal and energy. He accepted the presidency of the Air Board in May 1916, and in July became a permanent member of the War Committee of the Cabinet. When Mr. Lloyd George formed his Ministry in Dec., he was accorded a still more prominent position. Lord Lansdowne and Lord Crewe—the two leaders of parties in the Lords—both retired, and Lord Curzon

became the leader of the House with the office of President of the Council. He was chosen also to be one of the four ministers (the others being the Prime Minister, Lord Milner, and Mr. Henderson) who constituted the War Cabinet, and were charged with the permanent daily conduct of the war. After the Paris Conference he took over the Foreign Office from Mr. Balfour, retaining his leadership in the Lords. As leader, though not able to claim the sympathetic touch and close familiarity with their lordships' idiosyncrasies possessed by some of his predecessors, he exhibited remarkable intellectual powers and oratorical capacity, and gradually established his ascendancy in the House. In the Foreign Office he found a specially congenial sphere, as he had throughout his life made a study of the external relations of the country, and had travelled extensively. But foreign affairs in the years immediately following the war were still dominated by the Prime Minister, and by the Supreme Council.

Lord Curzon's first wife, by whom he had three daughters, died in 1906, and in 1917 he married, as his second wife, Grace Elvina, widow of Alfred Duggan, of Buenos Aires, and daughter of J. Munroe Hinds, U.S. minister in Brazil. He succeeded to the barony of Scarsdale on his father's death in 1916, and became a K.G. in the same year. He was created a marquess on the King's birthday in 1921.

**CUSHING, HARVEY** (1869- ), American surgeon, was born at Cleveland, O., April 8 1869. He graduated from Yale in 1891 and from the Harvard Medical School in 1895. After doing exceptional cerebral surgery abroad under Kocher at Berne and Sherrington at Liverpool he began private practice in Baltimore. Here at the age of 32 he was made associate professor of surgery at Johns Hopkins University, and at the hospital was placed in full charge of cases of surgery of the central nervous system. Yet he found time to write numerous monographs on surgery of the brain and spinal column and to make important contributions to bacteriology. He made (with Kocher) a study of intracerebral pressure and (with Sherrington) contributed much to the localization of the cerebral centres. In Baltimore he developed the method of operating with local anaesthesia, and his paper on its use in hernia gave him a European reputation. He has also made important contributions to the study of blood pressure in surgery. In 1911 he was appointed professor of surgery in the Harvard Medical School and surgeon-in-chief at the Peter Bent Brigham hospital in Boston. In 1913 he was made an hon. F.R.C.S. (London). In 1915, before the Clinical Congress of Surgeons in Boston, he showed the possibility of influencing stature by operating on the pituitary gland. During 1917-9 he was director of a U.S. base hospital attached to the B.E.F. in France. In 1918 he was made senior consultant in neurological surgery for the A.E.F. He held the rank of colonel in the Medical Corps of the U.S. army.

**CUST, HENRY JOHN COCKAYNE** (1861-1917), English journalist, was born in London: Oct. 10 1861. Educated at Eton and Trinity College, Cambridge, he entered the House of Commons as Unionist member for Stamford in 1890, but lost the seat in 1895. He was returned for Bermondsey in 1900 and sat till 1906. In 1892 Mr. (afterwards Lord) Astor made him editor of the *Pall Mall Gazette*, and for four years he held that post with distinction, gathering round him a brilliant staff (see 19.561). In politics and society his personal charm and *esprit* always gave promise of more than he ever achieved in the way of public life. But in Aug. 1914, at the outbreak of the World War, he founded the Central Committee for National Patriotic Organizations, and a Cust annual lecture "an some important current topic relating to the British Empire" was endowed in Nottingham University to commemorate his work. His *Occasional Poems* appeared in 1918, printed in Jerusalem. He was heir to the barony of Brownlow, a position which at his death fell to his brother, Adelbert Salisbury Cust (b. 1867). He died in London March 2 1917.

**CYTOLOGY** (see 7.710).—The effect of the work done in cytology up to 1910 may be summarized as follows.

The bodies of animals and plants are made up of units termed cells, which may be compared to the bricks in a brick wall. Each cell

is composed of a viscid semi-fluid material termed protoplasm, surrounded by an elastic membrane termed a cell wall. This wall is composed of cellulose in the case of the vegetable cell and may require considerable thickness and firmness. In the animal cell it is almost always very thin, and never consists of cellulose; but appears to agree in composition with the protoplasm, of which it may be considered a condensation. There is reason to believe that in most if not all cases the cell wall is porous, and that adjacent cells are connected with one another by bridges of protoplasm.

The activities of living cells are manifested in four ways, viz.:-

- (1) By movement, which takes the form of alternate contraction and expansion.
- (2) By secretion, i.e. by the production of definite substances which accumulate in the protoplasm, but which are finally extruded from the cell.
- (3) By the transmission of stimuli, so that shocks or stimuli of various kinds applied to one cell result in movement or secretion in a different cell.
- (4) By reproduction, which takes the form of the division of the cell into two daughter cells.

All these activities are dependent for their continuance on the consumption of a certain portion of the protoplasm; and if life is to persist and if the cells are to increase in number the waste must be repaired. This is effected by the taking in and assimilation of food; and this assimilation can only be carried out if there exists in the protoplasm a specially differentiated portion termed the "nucleus," which appears to be of rather different composition from the rest. For this reason it is customary to use the term "cytoplasm" for the extra-nuclear protoplasm.

Cells may be specialized for rapid movement or for the reception and transmission of stimuli or for secretion. Locomotor cells may be provided with freely projecting filaments, termed "cilia" or "flagella," which are capable of rapid vibration, and act the part of oars in propelling the animal, or their cytoplasm may contain threads termed "myonemes" or "muscular fibrils," which are capable of thickening and contracting; and these threads may be simple or cross-striated—i.e. composed of alternate discs of singly and doubly refracting material; cells provided with these threads are termed "muscle cells."

Cells devoted to the reception and transmission of stimuli are known as "nerve cells" or "neurons." Those which are situated at the free surface of the animal and which are provided with stiff processes of various kinds which are easily affected by stimuli, are known as "sense cells." Those which are more deeply situated have, in place of the stiff processes, one or more root-like branching processes known as "receptive dendrites." Stimuli when received are transmitted by outgrowths of the neurone known as "axons," and these axons, after preservation by fixing fluids, are seen to consist of a series of delicate fibres, the "neuro fibrillae." The axon ends in a brush of root-like processes called "terminal dendrites"; these dendrites are in contact either with the receptive dendrites of another neurone to which they hand on the stimulus, or with a muscle cell in which they cause contraction, or with a secretory cell in which they initiate secretion.

In the case of secretory cells the secretion may be fluid and poured forth at a free surface only, from which it is washed away by the currents of the circumbient medium. Of this type are the mucous cells which give rise to the slime which lubricates the skin of the humans, mouth cavity. On the other hand the secretion may take the form of fibres or another form of solid material and may be extruded from the entire surface of each cell so that the cell becomes in this way separated from its neighbours by masses of the secretion or, as it is now termed, the "intercellular substance." Cells of this kind are known as "connective tissue cells" and give rise to the various supporting tissues such as fibrous tissue, cartilage and bone.

The reproductive cells or "germ cells" are, as their name implies, cells which have the capacity of giving rise to a mass of cells out of which the body of a new individual is built up. They occur in many forms amongst the lowest grades of animals, i.e. the Protozoa, but amongst the higher animals, or Metazoa, they are remarkably constant in general characters, exhibiting practically the same forms throughout the whole range of animals from the sponges to the human race. They appear under two types, viz.—(1) a small motile male cell, which consists mainly of a head, which is a condensed nucleus, to which is added a vibratile flagellum termed the "tail," and (2) a much larger motionless female cell or egg in the cytoplasm of which there are deposits of food material known as yolk. Normally a male cell must unite with a female cell before development can be initiated, but the eggs of many animals can develop without this union and are then termed "parthenogenetic." In other cases where union with a male cell normally takes place eggs can be stimulated to develop without previous union with a male cell, and these cases are termed "artificial parthenogenesis."

Turning now to the consideration of the nucleus, we find that this is frequently invisible in the living cell, but when it can be made out it appears either as a clear vesicle (as in many eggs) or as a slightly more granular portion of the protoplasm (as in Amoeba). When, however, it is fixed and stained it exhibits a characteristic structure. It then appears as a vesicle containing a fluid termed the "nuclear

sap," and bounded by a membrane termed the "nuclear wall." The sap is traversed by a network of threads known as "linin fibres," and adhering to these fibres—suggesting the arrangement of beads on a necklace—are a number of granules termed "chromatin," because they attract and retain the colouring matter of the staining fluid so strongly. In addition there are usually one or two rounded bodies termed "nucleoli," which also attract stain strongly, but these are apparently not composed of exactly the same chemical substances as the chromatin granules—and it is possible by the use of certain stains to colour them differently from the tint assumed by the chromatin.

We have already seen that assimilation or the building-up of fresh protoplasm is impossible in the absence of a nucleus. This is proved by dividing a uninucleate amoeba into two, when it is seen that the non-nucleate piece, though capable of movement, cannot digest or assimilate food and, after a short period of activity, dies.

The division of the nucleus always precedes the division of the cell and this division is occasionally direct, i.e. by the process of simple constriction into two, or much more frequently indirect by the process termed "karyokinesis" or "mitosis." In this method the chromatin grains were believed to become aggregated into a continuous spirally coiled thread termed the "spireme," which then became segmented into a definite number of segments called "chromosomes." The chromosomes always appear in the same number in the same species at every division of the nucleus. Meanwhile the nucleolus or nucleoli disappear, apparently dissolved in the cell-sap; and the nuclear membrane becomes dissolved so that the cell sap is mingled with the cytoplasm; and then a small body termed the "centrosome," lying at the side of the nucleus in the cytoplasm, becomes discernible. The centrosome can occasionally be demonstrated lying at the side of the resting nucleus, but when it becomes visible in the process of mitosis it is seen to be in process of division into two. The chromosomes at the same time appear to be split longitudinally, whilst from the daughter centrosomes as they move apart a series of filamentous rays are developed, some of which ("astral fibres") extend out to the periphery of the cell, whilst others ("mantle fibres") become attached to the halves of the split chromosomes, one fibre from each centrosome going to a corresponding half of the chromosome. When the centrosomes have reached positions at opposite ends of the nucleus the mantle fibres proceeding from them have constituted the mitotic spindle; certain other fibres appear running directly from one centrosome to another in the axis of the spindle, which are termed "spindle fibres," whilst the split chromosomes, under apparent tension of the mantle fibres, have assumed positions lying at right angles to the axis of the spindle, and constituted what is called the "equatorial plate."

By a continuance of the apparent tension of the mantle fibres the two halves of each chromosome are dragged apart from one another, and eventually one set of half-chromosomes becomes massed together in the vicinity of each pole of the spindle, that is, close to each daughter centrosome. Each of such sets of chromosomes constitutes a daughter nucleus. The chromosomes become longer and thinner and more entangled with one another until the initial stage of a linin network with adhering chromatin granules is re-established, and round this a new nuclear wall is formed. The stages leading to the segmentation of the spireme thread and the solution of the nuclear membranes are termed the "prophases of mitosis"; those leading to the establishment of the equatorial plate are termed the "metaphase." The stage involving the separation of the halves of the chromosomes is termed the "anaphase" whilst the steps leading to the reconstitution of the daughter nuclei are termed the "telophase" of mitosis.

In the fertilization of the egg it is penetrated by the head of the spermatozoon which carries with it a segment of the tail termed the "middle-piece." The middle-piece is distinguished by its diameter from the thinner more distal part of the tail and it includes a centrosome which has been derived from the centrosome active at the last division of the sperm mother cell. Sometimes the distal part of the tail is left behind at the surface of the egg—sometimes it penetrates with the rest of the spermatozoon. In the latter case it remains passive in one cell of the embryo and is absorbed and is without influence on the hereditary potencies of the embryo, since it is never distributed to any but the one cell. All the paternal influence must be carried by the head, which is a condensed mass of chromatin; hence is derived the strong belief that not only is the nucleus the bearer of hereditary powers, but that the chromatin is the element of the nucleus in which they are concentrated.

The spermatozoon head, once immersed in the egg, swells up and assumes the characteristic structure of a nucleus: it acquires nuclear sap and a nuclear wall and its chromatin becomes resolved into the same number of chromosomes as are present in the egg nucleus. It is then known as the "male pro-nucleus," whilst the egg nucleus is termed the "female pro-nucleus." The centrosome derived from the middle piece gives rise to an enormous aster with radiating rays which is termed the "sperm-aster"; the two nuclei approach each other, and the sperm-aster then becomes changed into a spindle, and the chromosomes of both nuclei are arranged side by side on the equatorial plate of this spindle: so that when the compound or "zygote" nucleus divides equal portions of maternal and paternal chromatin are distributed to the first two cells of the embryo—and

the same thing follows at every subsequent division of the growing embryo, so that paternal and maternal chromatin is distributed in equal amounts to every cell of the body.

The ripe germ cell consequently possesses only one-half the number of chromosomes which the ordinary body cell possesses, and therefore at some time in its history a reduction of chromosomes must take place. The older view was that this occurred at one of the ripening divisions in consequence of the spireme becoming segmented into half the usual number of pieces: each of these pieces then exhibited a transverse split which was regarded as an indication of the belated appearance of the full number: at the first maturation division these halves were, however, supposed to be distributed to different cells, so that each daughter cell received only half the original number of chromosomes—this division was known as the "reduction division," or "meiotic division."

Since the chromosomes are usually invisible during the resting stage of the nucleus the question has been raised whether they retained their individuality throughout the whole growth cycle. Various considerations lead to the conclusion that their individuality is retained. In some cases where the number is very small, as in the cells of the nematode worm *Ascaris*, the chromosomes or at least their ends can be detected in the resting nucleus: moreover the chromosomes are not all alike, but differ in size and shape from one another, and to each paternal one there is a corresponding maternal one of similar size and shape, and it seems unlikely that, if they vanished in the resting stage, they should reappear in exactly the same form at the subsequent mitosis. It has been surmised that this individuality in form and size was an indication of a difference in function in distributing the hereditary qualities—and Boveri's<sup>1</sup> discovery that, when an echinoderm egg was entered by two spermatozoa, one alone fused with the female pro-nucleus whilst the other acted as an independent nucleus, so that at the first division the egg was divided into four cells—led to the same conclusion. For Boveri showed that under these circumstances an abnormal spindle was formed connecting all four daughter nuclei, and on this spindle the chromosomes were irregularly distributed: and that if the four resulting cells were separated and allowed to develop separately they developed abnormally; whereas Driesch<sup>2</sup> had proved that it was possible to rear any of the first four cells into which a normally fertilized egg divides into a perfect larva of diminished size. Since an unfertilized egg has also been induced by appropriate stimuli (see EMBRYOLOGY) to develop into a perfect larva, the conclusion is inevitable that one complete set of chromosomes (maternal or paternal) is essential to the normal development, and that cells receiving fewer chromosomes than these cannot grow into normal embryos; hence every kind of chromosome has its appropriate function to play in growth.

**Progress since 1910: the Cytoplasm.**—If we now turn to the great advances in our knowledge of the cell which were made in the 15 or 20 years ending in 1921, we may direct our attention first of all to the cytoplasm.

About 1899 Hardy published his first paper<sup>3</sup> in which he showed that the effect of the usual preservatives used in killing cells was to produce fibrous networks which had no counterpart in the living protoplasm, for exactly the same effect could be produced by the use of those same fluids on dead protoid: that in fact all colloid solutions, which he termed "sols," could be easily induced to pass into a semi-solid or "gel" phase in which the molecules were arranged in strings. From such networks the intervening fluid could be easily forced out, but by gently heating colloid solutions a different form of "gel" was produced, from which a pressure of several atmospheres failed to force the fluid out. In the first case the fluid contents were called the continuous phase and the fibres the disperse phase—but in the second case the fluid is locked up in tiny droplets inside the semi-solid gelatine and then the fluid was the disperse phase and the gelatine the continuous phase.

This discovery led to great scepticism as to the existence in life of the various structures seen in stained protoplasm. Fresh attention was given to the study of protoplasm in the living state and a most ingenious instrument designed by Kite<sup>4</sup> was used with effect by Chambers<sup>5</sup> for this purpose. This was an

<sup>1</sup> Th. Boveri, "Die Entwicklung dispermer Seekeleier," *Zellstudien*, No. 6 (Jena 1907).

<sup>2</sup> H. Driesch, "Die isolierten Blastomeren des Echiniderkeimes," *Archiv f. Entwicklungsmechanik*, vol. x. (1900).

<sup>3</sup> W. A. Hardy, "Structure of Cell Protoplasm," *Journal of Physiology*, vol. xxiv. (1899).

<sup>4</sup> G. L. Kite and R. Chambers, "Vital Staining of the Chromosomes and the Function and Structure of the Nucleus," *Science*, vol. xxvi. (1912).

<sup>5</sup> R. Chambers, "Microdissection Studies: II. The Cell Aster," *Jour. Exp. Zool.*, vol. xxiii. (1917).

excessively fine needle point of hard glass, bent at right angle to the glass tube from which it was drawn, fixed so that the point projected into a glass cell from the roof of which in a hanging drop was suspended the living cell or cells it was desired to explore. The needle could be manipulated by screws and the glass cell was mounted on the stage of a microscope. It was discovered that, generally speaking, the cytoplasm of a cell was a sol which was sometimes very thick and viscid and sometimes more fluid, but that the outer layer next the cell wall was a gel, of which indeed the cell wall might be regarded as an intensification. The various inclusions contained in the central cytoplasm, such as coloured granules, oil drops, etc.—could be freely pushed about by the needle. When, however, the nucleus of the cell approached mitosis, a change took place, and the astral rays were found to be strings of semi-solid material, as were also the mantle fibres of the mitotic spindle: the astral rays became connected with the peripheral gel surrounding the cell. On the other hand no centrosome could be detected in the living cytoplasm, but the sphere surrounding the centrosome was found to consist of fluid material which Chambers supposed to be squeezed out from the cytoplasm during the process of gelatinization of the astral rays, and from it proceeded fluid rays visible as clear streaks in the living cell which alternated with the astral rays. When the spindle divided, the mantle fibres passed again in the centre into the sol state, and this change propagated itself towards the poles as the two daughter cells separated from one another.

Examined in the same way, the cross-striated myonemes characteristic of the muscle cells of arthropods and vertebrates turned out to be composed of alternate discs of gels of different consistencies<sup>6</sup>; but no trace could be made out of neuro fibrillae in the living nerve fibre and the nerve cell, i.e. the body of the neuron containing the nucleus when examined in the living condition exhibited Brownian movement—i.e. the granules pulsed under the impact of freely rolling molecules—a circumstance which proves it to be in the sol condition.<sup>7</sup> On the other hand it should be recorded that Chambers<sup>8</sup> found that the cytoplasm of the ganglion cells from the central nervous cord of the lobster was a very viscid substance which could be pulled out into long threads without undergoing essential change. When pulled away from the nucleus a clear empty space appeared on the side of the nucleus in the direction of the pull, which was only slowly filled by inflow of the plasma from the two sides.

It will be observed that in living protoplasm the change from the sol to the gel condition is reversible and very frequently takes place, and many of the phenomena exhibited by living cells will find their explanation in this circumstance. Dr. Gates, professor of botany in King's College, London, has described to the present writer a beautiful demonstration once shown him by Chambers. It consisted of living spermatogonia (immature male germ cells) from the testis of an insect; these when stimulated by the needle could be induced to undergo mitotic division; the chromosomes could be seen like bunches of grapes of a slightly more granular consistency than the rest of the cytoplasm moving along the mantle fibres.

The Brownian movement affords a criterion of whether protoplasm is in the condition of a sol or a gel, although not an absolute one, for Chambers has shown that a sol may be so thick as to prevent this movement and yet it may be possible to move particles in it freely by means of the glass needle. Bayliss<sup>9</sup> has shown that the actively moving pseudopodia of amoeba show a vigorous Brownian movement, but that when

<sup>6</sup> G. L. Kite, "Studies on the Physical Properties of Protoplasm," *American Jour. Physiology*, vol. xxiii. No. 2 (1913).

<sup>7</sup> F. W. Mott, "The Bio-physical and Bio-chemistry of the Neuron," *Brit. Med. Jour.*, Sept. 1912.

<sup>8</sup> R. Chambers, "Report on Results obtained from the Microdissection of Certain Cells," *Trans. Roy. Soc. (Canada)*, vol. xii. Series 3, 1918.

<sup>9</sup> W. Bayliss, "The Properties of Colloidal Systems: IV. Reversible Gelation in Living Protoplasm," *Proc. Roy. Soc. (London)*, Series B, vol. xci. (1920).

they are caused to retract by electric shocks the movement ends, showing the conversion of the material into a gel.

Side by side with these observations on living protoplasm have gone renewed observations on its structure by means of more refined fixatives and stains. It has been shown that many of the older preserving fluids which were used to differentiate the nucleus and especially the chromatin of the nucleus from the cytoplasm, had a destructive effect in dissolving out many of the constituents of the cytoplasm.

A more refined technique has demonstrated the existence of bodies in the cytoplasm termed "mitochondria," which take the form of fibres or, less frequently, of small oval granules. What their function in the life of the cell is has not been determined. Meves<sup>1</sup> supposed them to be bearers of heredity like the chromosomes and described them as dividing into two at the division of the cell, the halves being distributed to the two daughter cells. Later researches by Gatenby<sup>2</sup> have failed to confirm this. He finds that the mitochondria are irregularly distributed at all divisions. Besides the mitochondria another element of the cytoplasm known as the "Golgi apparatus" has come to light. It is so called because it can be demonstrated only by the Golgi method of preservation and a staining, a method which involves the use of preserving fluids which contain osmic acid, followed by treatment with salts of silver. In young cells this apparatus takes the form of a wreath surrounding the centrosphere or area of clear cytoplasm which envelops the centrosome in the young cell—i.e. in the cell just after it has originated by division of the mother cell. During the growth of the cell this wreath dissolves into smaller elements which become scattered throughout the cytoplasm interspersed amongst the mitochondria. These elements in their typical form consist of disc-like bodies made up of a substance which stains faintly, edged for half their circumference by a rim of stains intensely black with the reagents which are used to differentiate the Golgi apparatus. The earlier observers failed to note the disc-like form of these elements and fixed their attention solely on the deeply staining rim, which they regarded as a rod and to which they gave the name "dirty-some," but Bowen<sup>3</sup> has brought out clearly the real structure of these bodies. The fact that the Golgi apparatus reacts strongly with osmic acid has been held to prove that it must be partially made up of a substance allied to lecithin, which contains a fat group in the molecule.

The most interesting fact about both mitochondria and the Golgi apparatus is that the elements of both increase in number by transverse division, and hence they cannot be regarded as food reserves, or temporary deposits of excreta, but are in some sense elements of the living cytoplasm. What relation they have to the general metabolism of the cell is not yet clear. Efforts have been made to show that in certain cells they are the centres of fat formation, and in pancreatic cells of the characteristic pancreatic secretion—but these endeavours have not yet carried conviction to the minds of cytologists. Much further work on these lines is needed before certainty can be obtained. In the formation of the spermatozoa of insects and mollusca the mitochondria and the Golgi apparatus play a very definite part which has been elucidated by Gatenby.<sup>4</sup> The former give rise to a sheath surrounding the base of the tail which forms the middle-piece of the spermatozoon; the latter becomes largely metamorphosed into the "acrosome" or pointed structure which is attached to the front of the head of the spermatozoon, and plays the part of a spear-head when the spermatozoon reaches and penetrates an egg. The remnant of the Golgi apparatus migrates round the head and eventually forms a bead projecting from the tail which is eventually rubbed off. The middle-piece penetrates the egg, but undergoes no growth there; it remains embedded in one cell of the embryo and is eventually absorbed so that the mitochondria can have no function as bearers of heredity. In living cells particles resembling mitochondria and Golgi discs<sup>5</sup> in their shape have been observed, oscillating in the typical Brownian manner, whence it is inferred that these bodies really exist as

such in living protoplasm and are not merely artefacts produced by preserving reagents.

**Nuclear Structure.**—As regards advances in our knowledge of nuclear structure, we may note especially the demonstration of the presence of sex chromosomes in many animals. Already before 1915 the fact was known that in certain cases an odd chromosome was present in the ripening germ cells, that is, a chromosome which in one of the ripening divisions of the germ cells passed without dividing to one pole of the mitotic spindle. But Wilson<sup>6</sup> showed that not only are such odd chromosomes found in the developing sperm cells of many insects but that their presence is related to the determination of sex. The odd chromosome sometimes divides like the rest at the first maturation division, but at the second passes undivided to one pole of the spindle. Sometimes it migrates to one pole in the first division and divides like the other chromosomes at the second; in either case its presence causes the formation of two types of germ cell, one possessing one more chromosome than the other. In the case of these insects the ripening eggs are all found to possess the same number of chromosomes; and this number is equal to that found in the sperm cells which have the larger number. It is clear, therefore, that when the eggs are fertilized with the sperm, two types of fertilized egg should be found; one characterized by having one more chromosome than the other, and these eggs should give rise to animals all of whose cells should have nuclei with a number of chromosomes equal to those found in the fertilized egg from which each one arose. If we now examine the cells of the testes, it is discovered that they have nuclei with the smaller number of chromosomes, whereas the cells of the female gonads nuclei with the larger number of chromosomes. Therefore it is clear that the male has been produced by the fertilization of an egg by a spermatozoon devoid of the odd chromosome; whereas a female arises when an egg is fertilized by a spermatozoon containing this chromosome.

Wilson showed further that sometimes the odd chromosome has a mate with which it pairs but which is much smaller than itself. This mate is denominated by Wilson the Y chromosome, whereas the large one which alone is present in the case of many insects is termed the X chromosome. The male germ cell which receives the Y chromosome gives rise to a male when it fertilizes an egg. Still other modifications, which lack of space prevent us entering into, are recorded by Wilson. There has been a diligent search for these six chromosomes in the germ cells of other animals, and enthusiastic investigators have announced their discovery in the spermatids of echinoderms, vertebrates and even of man himself. These cases cannot yet be taken as fully proved, mainly owing to the fact that the number of chromosomes in the nuclei of these spermatids is large, and accuracy of count is difficult.

The earlier conception of the preparation for the meiotic division of the nucleus has been that the chromosomes became arranged in a continuous thread termed the spireme, which then became transversely segmented into the characteristic number of chromosomes. This conception has gradually been superseded by a much simpler one, viz. that the chromosomes persist as long leaped threads during the resting stage of the nucleus and that these long U-shaped filaments become shorter and thicker as mitosis approaches. To this change of view many workers have contributed, amongst whom we may specially mention Agar<sup>7</sup> and Hogben.<sup>8</sup> The free ends of these U's are attached to a spot on the nuclear wall immediately outside which lies the centrosome. In the preparation for the reducing division of the germ cells, when the chromosomes first become distinguishable they are said to be in the "leptotene" stage. These leptotene threads then approach one another in pairs, and these pairs are termed "zygotene" threads. Each pair fuses to form a single thicker thread known as "pachytene," and in this way the number of chromosomes becomes reduced to one half. Though formerly an end-to-end fusion of corresponding chromosomes was strongly believed in, there is to-day no unequivocal evidence that such an end-to-end union (known as "metasyndesis") ever takes place. On the contrary, in a continually increasing number of cases a side-by-side union ("parasyndesis") has been demonstrated.<sup>9</sup> Lately Hogben has shown that parasyndesis takes place in the cockroach, an insect which has formerly been regarded as presenting the typical case of end-to-end union.

<sup>1</sup> F. Meves and J. Duesberg, "Die Spermatozytenteilungen bei der Hornisse," *Archiv f. Mikroskopische Anatomie*, vol. lxxi. (1908); F. Meves, "Die Chondriosomen als Träger erblicher Anlagen," *ibid.*, vol. lxxii. (1908).

<sup>2</sup> J. Bronte Gatenby, "The Cytoplasmic Inclusions of the Germ Cells," *Quart. Journ. Micr. Sc.*, vol. lxi. (1917).

<sup>3</sup> R. H. Bowen, "Studies on Insect Spermato-genesis: I. The History of the Cytoplasmic Contents of the Sperm in Hemiptera," *Biol. Bulletin*, vol. xxxix. (1920).

<sup>4</sup> J. B. Gatenby, *loc. cit.*; "On the Origin of the Golgi Apparatus of the Middle-piece of the Ripe Sperm of Cavia, etc.," *Quart. Journ. Micr. Sc.*, vol. lxxv. (1921).

<sup>5</sup> M. R. Lewis and W. H. Lewis, "Mitochondria in Tissue Culture," *American Jour. Anat.*, vol. xvii. (1915).

<sup>6</sup> J. B. Gatenby, "The Cytoplasmic Inclusions of Germ Cells: VII. Modern Technique of Cytology," *Quart. Journ. Micr. Sc.*, vol. lxxv. (1920).

<sup>7</sup> E. B. Wilson, "Studies of Chromosomes: I. The Behaviour of the Idiochromosomes in Hemiptera," *Jour. Exp. Zool.*, vol. ii. (1905); "Studies of Chromosomes: II. The Paired Microchromosomes, Idiochromosomes, etc., in Hemiptera," *ibid.*, vol. ii. (1905); "Studies of Chromosomes: III. The Sexual Differences of the Chromosome Groups in Hemiptera," *ibid.*, vol. iii. (1906).

<sup>8</sup> W. Agar, "The Spermatogenesis of Lepidopteran Paradora," *Quart. Journ. Micr. Sc.*, vol. lvi. (1911).

<sup>9</sup> L. T. Hogben, "Studies on Synapsis: II. Parallel Conjugation and the Prophase Complex in Periplaneta," *Proc. Roy. Soc.*, Series B, vol. xci. (1920).

<sup>10</sup> The union of two sister chromosomes in the prophases of the reducing division is frequently termed "synapsis." We have avoided this term because it has also been used to denote the bouquet contraction of the chromosomes (see below).

The pachytene stage is characterized by a great contraction of the chromosomes, which leads to their being gathered up in a characteristic "bouquet" at one side of the nucleus—of course that side adjacent to the centrosome. Then the nuclear wall is dissolved and the chromosomes separate as if repelled from one another: this process is known as "diakinesis." During this process the line dividing the sister chromosomes which paired may reappear, and according to Agar in *Lepidosiren* these chromosomes may entirely separate from one another, only to pair again at a slightly later stage in mitosis. In most cases, however, this complete separation does not take place, but only a partial separation, which leads to the compound chromosome assuming the form of a ring or loop. Each half of the ring corresponds to one of the two original chromosomes, and these halves are dragged apart in the ensuing mitotic division. Most frequently each half shows a constriction in the middle of its length, which was formerly interpreted as a precocious appearance of the longitudinal division of the chromosome which is consummated in the second maturation division. For this reason the name "tetrad" has been bestowed on the shortened, thickened and partially split chromosome. Agar<sup>1</sup> has shown, however, that in the vast majority of cases this constriction has no relation whatever to the splitting of the chromosome in the second maturation division.

Modern theories of heredity assume that a chromosome consists of a linear series of rudiments, each of which has its particular part to play in the up-building of the embryo. A side-by-side pairing enables us to see how corresponding rudiments belonging to maternal and paternal chromosomes are brought together: an end-to-end pairing would of course render such a process impossible.

But the side-by-side union of homologous chromosomes does not always take place in a straight line. In the germ cells of the newt *Bolitroschelus* Janssens<sup>2</sup> has shown that one filament becomes spirally wrapped round the other. He believes that he has demonstrated that each filament likewise becomes split longitudinally, and that when the two chromosomes separate the now separated chromosomes are no longer the same as those which became united with one another but each has appropriated one strand of the other. Janssens' theory in its extreme form is not accepted by other cytologists; but he certainly has demonstrated cross connexions between the pairing chromosomes, and if the chromosomes are the actual bearers of the hereditary qualities, as seems to be proved from the fact that they alone constitute the head of the spermatozoon, then there are a good many facts (see GENETICS) which seem to require for their explanation an interchange of substance between the two paired chromosomes. This is termed by Morgan the "cross-over."

In the ripening of the egg very peculiar phenomena occur which have only recently received an explanation. The unripe female germ cells or oögonia show nothing peculiar in their mitosis, but during the prophase of the first ripening division an enormous increase in size of the egg cell takes place. The leptotene threads are at first clearly visible and can be seen to pass into the pachytene stage, but then they fade from view. The nucleus becomes very large and gorged with nuclear sap, from which circumstance is derived the name, "germinal vesicle," which the older authors bestowed upon it. The nucleolus becomes large and conspicuous. At the close of the growth period the nucleolus has been completely dissolved; the nuclear wall disappears and the nuclear sap mingles with the cytoplasm: then the chromosomes can again be detected as minute tetrads which begin to arrange themselves on the mitotic spindle of the first ripening division. Now by the examination of specially favourable cases it has been shown that what happens during this episode of growth is that the chromosomes swell up, become pressed against the nuclear wall and almost lose their capacity for absorbing stain. It seems to be clear that a chromosome consists of at least two substances—a framework which does not stain and an embedded material which stains intensely, and to which alone the name chromatin is, properly speaking, applicable, and that during the growth of the egg cell the framework swells up enormously. De Baehr<sup>3</sup> has shown that in the male germ cells of the annelid *Succinarius*, a similar growth period exists, though it is of very much shorter duration than the corresponding period in the life of the female germ cell, but, short though it is, it is long enough to cause the chromosomes to swell up and temporarily fade from view.

The nucleolus or "germinal spot" of the older authors, which is so conspicuous a feature in the unripe egg, has formed the subject of some most interesting researches. Hogben has shown that in the cockroach, *Periplaneta*, the nucleolus becomes vacuolated and that portions of it are extruded and that these can be recognized by their peculiar staining properties, scattered in the nuclear sap and even in the act of passing through the nuclear membrane. They can also be detected in the cytoplasm outside the nucleus. There seems to be no reasonable doubt that it is by this process of vacuolation and emission of pieces of itself that the nucleolus ultimately disappears.

<sup>1</sup> W. Agar, "Transverse Segmentation and Internal Differentiation of Chromosomes," *Quart. Jour. Micr. Sc.*, vol. lxxxviii. (1912).

<sup>2</sup> F. A. Janssens, "La Théorie de la Chiasmotomie," *La Cellule*, vol. xxv. (1909).

<sup>3</sup> V. B. de Baehr, "La Spermatogenèse et l'Oögenèse chez le Succinarius Major," *La Cellule*, vol. xxx. (1906).

Gatenby<sup>4</sup> and Hogben<sup>5</sup> have shown that in certain cases these emitted fragments may assume the appearance of nuclei, since they seem to secrete round themselves both nuclear sap and a nuclear wall. Ultimately they all disappear. Though it has not been possible to connect them directly with the formation of yolk spheres, yet it is an interesting fact that the beginning of this emission from the nucleolus coincides with the first appearance of yolk spheres, and as we know by experimental evidence that the nucleus presides over assimilation, it is a reasonable hypothesis that the absorption of these pieces of nucleolus in the cytoplasm leads directly to the synthesis of yolk. It has recently been asserted by Carleton<sup>6</sup> that in ordinary tissue cells where the same disappearance of the nucleolus occurs as in the small growths, this is not complete—that a small kernel remains which can be stained in certain silver salts—and that the kernel takes its place on the mitotic spindle at the next division of the cell. This "nucleolus," as Carleton terms it, becomes equally divided into two and the halves pass into the two daughter cells. If these observations should be confirmed we should have in the nucleolus a part of the nucleus as permanent as are any of the chromosomes, the function of which was to form a centre for the synthesis of a mass of chromatin which constitutes the nucleolus and is destined to be emitted into the cytoplasm, where it no doubt profoundly affects the metabolism and determines the formation of cytoplasmic structures.

**Parthenogenesis.**—We have seen that the normal history of the egg cell is to undergo two ripening divisions, at the first of which the chromosomes are reduced in number by one half. When the egg is fertilized by the spermatozoon not only is the full number of chromosomes restored by the addition of those brought in by the spermatozoon but the division of the egg is initiated by the centrosome which is carried into the cytoplasm of the egg along with the head of the spermatozoon. An interesting question now comes as to what happens in the case of those eggs which develop without fertilization—or, as it is termed, "parthenogenetically."

Now parthenogenesis may be either artificially induced or it may be a natural event in the history of the species. If we take the case of "naturally" parthenogenetic eggs first, we find that a great deal of light has been thrown on the subject by the investigations of de Baehr.<sup>7</sup> He took for his subject the plant-louse *Aphis palmarum*, the eggs of which develop without the aid of the male throughout the summer. He shows that in these eggs the preparations for the reducing division occur. Out of the apparently irregular chromatin network leptotene threads differentiate themselves. These pair so as to form thick pachytene threads—but then at diakinesis these pairs become completely dissociated from one another, and the full number of chromosomes is thus established. Then the period of growth supervenes and the chromosomes become indistinct, but when they reappear in the metaphase they are in the full number and only one maturation division takes place at which all the chromosomes are longitudinally cleft. From these facts de Baehr draws the conclusion that the reducing division is suppressed and only the second maturation division takes place.

A somewhat different case is presented by the egg of the bee. The egg if fertilized gives rise to a female but if unfertilized grows into a male. In the latter case of course the resulting animal has in all its nuclei only the reduced number of chromosomes. When the male produces germ cells, the reducing division is suppressed. The nucleus of the spermatozoon enters on the prophase of mitosis and the cell divides, but one of the daughter cells is devoid of a nucleus and dies. The nucleus in the other cell goes back into the resting stage; and then like the egg in *Aphis*, it enters on a single maturation division in which the chromosomes are divided longitudinally, and the spermatozoon has therefore the same number of chromosomes as that possessed by the nuclei of the tissue cells of the male, which is the reduced number as compared to the number in the nuclei of the cells of the fertilized female.

In still other cases, as in the eggs of the small crustacean *Artemia*, the two ripening divisions may occur, but the first one can give rise to a nucleus which is not extruded as a polar body but remains in the egg and, reuniting with its sister nucleus, restores the full number of chromosomes.

Parthenogenesis can, however, be brought about in eggs which normally require fertilization by the application of external stimuli.<sup>8</sup> This stimulus in the case of the frog's egg may take the form of a prick with a needle. Under these circumstances an immense development of astral fibres takes place, centring on a particle lying

<sup>4</sup> J. B. Gatenby, "The Cytoplasmic Inclusion of Germ Cells: VI. On the Origin and Probable Constitution of the Germ Cell Determinant, etc.," *Quart. Jour. Micr. Sc.*, vol. lxxv. (1920).

<sup>5</sup> L. T. Hogben, "Studies on Synapsis: III. The Nuclear Organization of the Germ Cells in *Libellula Depressa*," *Proc. Roy. Soc., Series B*, vol. xcii. (1921).

<sup>6</sup> H. M. Carleton, "Observations on an Intracellular Body in Columnar (Male) Epithelial Cells of the Intestine," *Quart. Jour. Micr. Sc.*, vol. lxxv. (1920).

<sup>7</sup> V. B. de Baehr, "Recherches sur la Maturation des Oötes parthenogenétiques dans l'*Aphis*," *La Cellule*, vol. lxxx. (1920).

<sup>8</sup> For a full account of recent work see A. Brachet, "L'Évolution des Facteurs de l'Oögenèse," *Encyclopédie Scientifique* (Paris 1916).

adjacent to the egg nucleus, apparently a centrosome formed from this nucleus. This aster is speedily transformed by division into a short spindle with a radiating aster at each end of it. If this spindle lies near enough to the surface of the egg to initiate a division furrow, parthenogenetic development may begin. It is interesting to observe, however, that the mitotic spindle formed by the nucleus of the unfertilized egg is only  $\frac{1}{2}$  of the length of the spindle formed by the fertilized egg, so that the size of the spindle is directly related to the number of chromosomes.

In the sea-urchin's egg the primary stimulus, which is usually momentary immersion in a fatty acid (such as butyric), only produces an aster on which the chromosomes are distributed but which is unable to metamorphose itself into a spindle. If, however, the eggs are subsequently immersed in "hypertonic" sea water—that is, sea water in which the percentage of salt is raised above the normal amount, then one or more accessory asters are formed in the cytoplasm. Whence the particles arise which act as centrosomes for these asters has never been ascertained; that they have previously been emitted from the nucleus is a pure assumption. If only one accessory aster has been formed a mitotic spindle is formed between it and the aster which arises round the egg nucleus. On to this spindle migrate the chromosomes. A regular equatorial plate is formed, and division of the nucleus and of the whole egg ensues and development is initiated. As the accessory aster is usually smaller than the primary egg aster, the two blastomeres into which the egg divides are of unequal size, and we thus learn that the size of the daughter cells into which a given cell divides is related to the relative sizes of the asters at the two poles of the spindle.

**Conclusion.**—From the foregoing sketch the reader will gather that the science of cytology had attained in 1921 an extremely interesting stage of development. New discoveries had poured in, the exact significance of which was not yet fully understood, and although we had glimmerings of light they serve rather to pose than to answer questions. What, for instance, is the significance of the mitochondria and the Golgi apparatus? They surely must have some very important function in cell life, for the more research is pushed the wider seems to be their distribution. They have been recorded from Protozoa and from tissue cells of both animals and plants, as well as from eggs and spermatozoa, yet the only function which so far can definitely be assigned to them is the production of transient structures in the ripe spermatozoon. What is the meaning of the centrosome, and how is it related to the formation of astral rays? It cannot be detected in the living cell and yet the study of stained cells would lead us to regard it as a permanent cell organ—typically outside and independent of the nucleus and, like the nucleus, handed on by division from a cell to the daughter into which it divided. Yet, as we have seen, it can be formed *de novo* in the cytoplasm by the action of hypertonic sea water—and Lillie<sup>1</sup> has shown that it can be formed *de novo* from the nucleus. In the fertilization of the eggs of the annelid *Nereis* the spermatozoon penetrates the egg membrane but slowly. Lillie centrifuged eggs in which the head had penetrated but in which the middle-piece with the centrosome were still left outside and he succeeded in tearing away the middle-piece altogether. After the cessation of the centrifugal force the mutilated head completed the penetration of the egg and developed a new centrosome by the emission of a particle from itself which was just as effective in forming the first spindle as the original centrosome.

The astral rays and the mitotic spindle are formed by the gelation of the cytoplasm; yet their formation is dependent on the activities of the chromosomes; for an unfertilized egg responds to stimulation not only by the production of an aster but by the resolution of its chromatin into chromosomes; and the length of the spindle which is formed is dependent on the number of chromosomes.

The nucleus must in some way control the growth of the cytoplasm, and genetic experiments indicate (*see GENETICS*) that each type of chromosome has a particular function to play in the building-up of the embryo, yet the only emission from the nucleus which has so far been detected has been that of nucleolar material.

Finally, the constitution of living cytoplasm seems to be normally that of a thick colloid solution, which at times changes

<sup>1</sup> F. B. Lillie, "Studies on Fertilization in *Nereis*," III. and IV., *Jour. Exp. Zool.*, vol. xii. (1912).

to that of the gel condition. It baffles our imagination, however, to conceive how a solution can be the seat of internal structure and how in particular a nerve cell, with all its inherited and acquired aptitudes or "engrams," can be in life nothing more than a thick syrup.

**REFERENCES.**—W. E. Agar, *Cytology, with special reference to the Metazoan Nucleus*; A. Brachet, "L'Œuf et les Facteurs de l'Ontogenèse," *Encyclopédie Scientifique* (1916); L. Doncaster, *Textbook of Cytology* (1908); E. B. Wilson, *The Cell in Development and Inheritance* (1906). (E. W. MACG.)

**CZECHOSLOVAKIA** (*Čiškoslavenko, Čiškoslavenšká Republika*)—The republic of Czechoslovakia is a new creation in respect of its name and state-form only. Its modern history as an independent entity begins with the dramatic collapse of the Austro-Hungarian Monarchy at the close of the World War, and the definitive proclamation of Czechoslovak independence on Oct. 28 1918. Some of its constituent territories, however, notably Bohemia and the lands of the Bohemian crown (Moravia, Silesia, Lusatia) enjoyed, up to the year 1620, many centuries of independent existence and played an important, sometimes a dominating, part in the political and religious history of central Europe.

The republic has a pop., according to the census of 1921, of 13,595,818, and an area of about 55,000 sq. m. (approximately the size of England and Wales). It comprises three great natural regions: (1) Bohemia (2) Moravia and Silesia, (3) Slovakia and Russia (Sub-Carpathian Russia = *Podkarpatská Rus*). Bohemia, with an area of some 20,400 sq. m., has a pop. of 6,664,932; Moravia, with 8,600 sq. m., 2,660,737 inhabitants; Silesia, 1,800 sq. m., and 670,937 inhabitants; Slovakia, 20,000 sq. m., and 2,993,479 inhabitants; Russia, 5,000 sq. m., and 605,731 inhabitants. The whole is about 600 m. long and has a maximum breadth of 185 miles. In respect of population it occupies the tenth place among European countries; in respect of size the fourteenth place; in density of population the seventh.

The frontiers were fixed by the Peace Treaties of St. Germain, Versailles and Trianon, while a portion of the ancient principality of Těšin (Teschen) was adjudicated to it by the Paris Conference (July 1920). On the W. and N., where it borders upon Bavaria, Saxony, Prussia and Poland, it is enclosed by mountains, some of them of very considerable height, which form on those sides a natural and strategic frontier. In Bohemia the highest peak Sněžka (Schneekoppe) has an altitude of 5,216 ft., in Slovakia the summits of the Carpathians and of the High Tatras rise to a height of between 7,000 and 8,000 ft. South of these ranges lie fertile and well-watered plains and lowlands extending to the borders of Austria, Hungary and Rumania. Some 60% of the entire area of the republic is included in the basin of the Danube, the rest being traversed by the Labe (Elbe) and the Vltava (Moldau), the former passing in particular through regions remarkable for their rich fertility. Some one-third of the entire surface of the country is covered by forests. The climate of the republic is a medium between a maritime and continental one.

Prague, the capital (677,000 inhabitants), is picturesquely situated on the Vltava and justly famous for its architectural beauty. Bratislava (Pressburg), the capital of Slovakia, with its great Danubian harbour, is the gateway of central European trade to the East and the Balkans. Other towns of importance in the republic are Brno (Brünn), with 200,000 inhabitants, the capital of Moravia, and the centre of an old established and flourishing textile industry; Pilsen (Pilsen) with 100,000 inhabitants, famous for its beer and as the seat of the Škoda iron works; Košice (Kaschau), the commercial centre of eastern Slovakia; and Užhorod (Ungvár), the capital of Russia. Of German towns in Czechoslovakia (most of them with a considerable Czechoslovak minority), Liberec (Reichenberg), and Jablonec (Gablonz), are important industrial centres. Carlsbad (Karlovy Vary), and Marienbad (Mariánské Lázně), are famous spas. Czechoslovakia indeed is one of the richest states of Europe in mineral and health-giving waters, and possesses more than 200 watering places and health resorts. Besides Carlsbad and



Marienberg, Franzensbad, Teplice (Teplitz), Poděbrady (in Bohemia), Luhačovice in Moravia, Píšťany, Trenčianske Teplice, Sliach and Štrbské Pleso (4,100 ft. above sea-level) in Slovakia, are noted. At Jáchymov (Joachimsthal), in North Bohemia, radium is produced.

**Ethnology.**—The population of Czechoslovakia is ethnologically of a mixed character. The prevailing element is that of the Czechs (7 millions), with whom the Slovaks (2½ millions) form one people; indeed as long ago as the 9th century the kingdom of Great Moravia, with frontiers roughly identical with the present boundaries of the Czechoslovak Republic, was the creation of the Slav people, who occupied in common a territory stretching from W. Bohemia to the Carpathians.

The Czechs and the Slovaks, or, to give them their united name, the Czechoslovaks, are a branch of the great Slav family of which the Russians are the most numerous and the most important member and to which the Serbo-Croats with the Slovenes, the Poles, the Bulgarians and the Wends of Germany also belong. Even after the conquest of Slovakia by the Hungarians, which resulted in Slovak territory being separated from Czech territory till they were reunited in 1918, an intellectual connexion between the two branches of the one family was always maintained, and some of the foremost names in Czech literature are those of writers who were Slovaks by birth. The difference between the Czech language and the language spoken in Slovakia is merely dialectical and the struggle for independence, culminating in the declaration of the Czechoslovak State, has emphasized and developed the sentiment of Czechoslovak unity. It is not without interest to note that the three principal leaders of the movement for independence were a Moravian or Slovak descent (Masaryk), a Slovak (Gen. Stéfánik), and a Czech (Dr. Beneš).

Of the non-Czechoslovak races in the republic the Germans are the most numerous, numbering some 3½ millions, chiefly dispersed along the W and N frontiers of Bohemia and in Moravia and Silesia. Their presence is largely the result, firstly of a colonization which was favoured by the Bohemian kings and princes of the 12th and 13th centuries, and secondly of a policy of Germanization pursued by the Habsburg rulers from the date of the battle of the White Mountain in 1620 (when the Czechs lost their independence) up till the very close of the World War.

On the day following the attainment of Czechoslovak independence, Oct. 29 1918, the Germans of Bohemia and Moravia—the so-called Sudetean Germans—declared the districts where they predominated a province of the new Austrian State, which had been constituted some eight days previously. It was not until the Treaty of St. Germain was concluded on Sept. 10 1919 and the Austrian Government released the Germans from the oath of allegiance they had taken to the new Austrian Republic, that the Germans desisted from openly fighting against incorporation in the Czechoslovak Republic. Their claim to self-determination was rejected by the Peace Conference. From the mere presence of the Germans within

the historic frontiers of the Czechoslovak State it would indeed have been difficult, with justice, to deduce a right of self-determination, that is to say, the right, in this case, of retaining all the fruits of misused power. In Slovakia the Slovaks were subjected to a similar system of Magyarization. The Hungarian census of 1910 purported to show that in Slovakia there were 1,697,532 Slovaks and 901,793 Hungarians. The correct figures, however, were shown by the census of 1919 to be Slovaks 2,141,000, Hungarians 665,000.

Other nationalities occupying portions of the Czechoslovak Republic are Ruthenians 600,000 and Poles 250,000. On the other hand there are some 500,000 Czechoslovaks in Austria, 450,000 in Hungary, more than 200,000 in Yugoslavia and Rumania, and over 800,000 in America.

Special provision is made in the Constitutional Charter of the republic (in accordance with the terms of the Treaty of St. Germain) for the protection of national, religious and racial minorities. Difference in religious belief, confession or language, constitute no obstacle to any citizen in regard to entry into the public services or offices, to the attainment to any promotion or dignity, or to the exercise of any trade or calling. In towns and districts in which there lives a considerable section (20% or more) of citizens speaking a language other than Czechoslovak, schools are to be provided, the instruction to be imparted in the language of that minority. Such a minority has also a right to a proportionate amount of the funds set aside by the State or by the local authorities for purposes of education, religion or philanthropy. The courts of justice and the public offices are also required to pay due regard in respect of language to the desires of a minority which numbers at least 20% of the inhabitants of the locality. Every act tending to force a citizen to abandon his nationality—in other words oppression of a citizen on account of his race—is expressly prohibited.

**Creation of the Republic.**—When in July 1914 Austria commenced hostilities against Serbia, thus bringing about the World War, this act of aggression took place against the will of the Czechs and Slovaks, at that time subject to Austrian and Hungarian rule respectively. Open protest or organized revolt, however, was impossible owing to the proximity and indeed the presence in overwhelming numbers of German and Hungarian troops, who were expressly garrisoned among the Czech population in order to stifle any possible outburst of national and pro-Ally sentiment. Direct political action was equally impossible, as the Austrian Parliament was suspended. Whenever opinions did happen to be expressed which could be construed as criticism of Austria or Germany the offenders were speedily punished, and it was not long before the political leaders of the Czechs and Slovaks found themselves in confinement, some of them under sentence of death, while the Czech and Slovak press was subjected to a rigorous censorship and many of its organs prohibited from appearing. Some of the political leaders escaped over the frontier—among them Prof. Thomas Garrigue Masaryk and Dr. Eduard Beneš, who were subsequently to lead a success-

<sup>1</sup> For an Austrian view of the nationality question, see the article AUSTRIAN EMPIRE (Ed. E. B.).

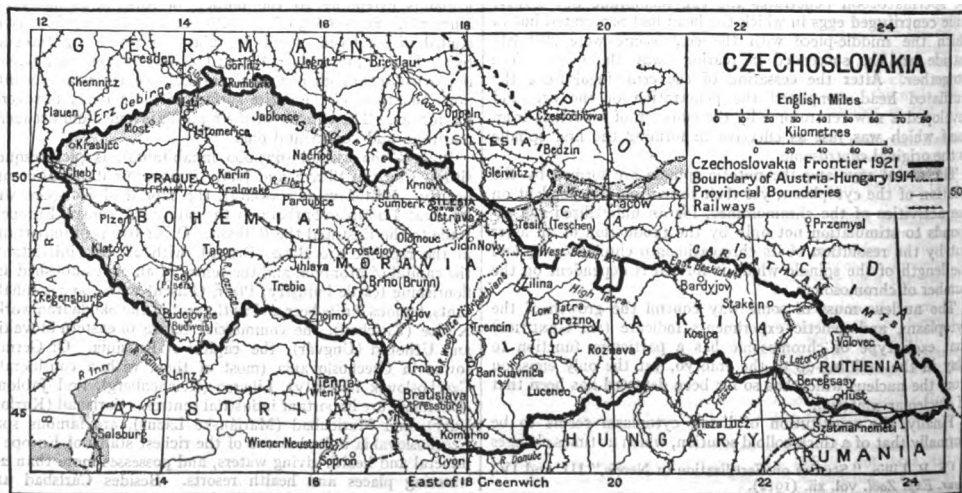

ful campaign abroad for the destruction of the Austrian Monarchy and the attainment of Czechoslovak independence.

The persecutions, sometimes revolting in their cruelty, to which (on account of their pro-Ally sympathies) the Czechs were subjected during the first two years of the war, had the effect of uniting all the different political parties into one single national block; and when the Austrian Parliament was at length convoked in May 1917 the Czech parties made a unanimous declaration that it was their aim to work for the union of Czechs and Slovaks as one people in an independent state.

As the war proceeded, further declarations of national and anti-Austrian sentiment were made, the most notable being the "Twelfth Night Manifesto," issued at Prague on Jan. 6 1918, in which all the Czech deputies of the Austrian Reichsrat and of the Diets of Bohemia, Moravia and Silesia unanimously demanded full independence and representation at the future conference which should conclude peace in Europe.

Meanwhile the Czechs, who were as Austrian subjects obliged to serve in the Austrian army, lost no opportunity of passing over to the Allies. Of 70,000 prisoners taken by Serbia early in the war 35,000 were Czechs. Of these 32,000 perished during the Serbian retreat or died of fever or cholera. The remnant, 3,000 in number, proceeded to France and there joined the Czechoslovak legions already fighting on the French front. Of a total of 600,000 Czech troops in the Austrian army over one-half surrendered to the Allies. In Russia a Czechoslovak legion was formed at the outset of the war, and later this grew into a regular army which by 1918 numbered 200,000 men.

The activities of Prof. Masaryk in Russia, England and America, enthusiastically supported by his compatriots living abroad, and especially by the Czechs and Slovaks who had emigrated to the United States, the self-sacrificing valour of the Czechoslovak legions on the French, Italian and Russian fronts, and the work of the Czechoslovak Council with its headquarters at Paris, moved the Allies to acknowledge the last-named body as the *de facto* Provisional Government of the Czechoslovak State. On July 13 1918 a Czechoslovak National Council, representing all parties, was formed at Prague as a complement to the National Council already existing at Paris. This was the first direct step taken at home towards the establishment of the new State.

On Aug. 9 1918 the British Government issued the following declaration:—

"Since the beginning of the war the Czechoslovak nation has resisted the common enemy by every means in its power. The Czechoslovaks have constituted a considerable army, fighting on three different battle-fields and attempting, in Russia and Siberia, to arrest the Germanic invasion. In consideration of their efforts to achieve independence, Great Britain regards the Czechoslovaks as an Allied nation and recognizes the unity of the three Czechoslovak armies as an Allied and belligerent army waging a regular warfare against Austria-Hungary and Germany. . . ."

This declaration materially helped to seal the fate of Austria, and implicitly recognized Czechoslovak independence as an accomplished fact. France and Italy, by accepting the assistance of Czechoslovak legions on the French and Italian fronts, had already practically acknowledged Czechoslovakia's claims (Briand, 1916). In the first week of Sept. 1918 the United States of America and Japan issued declarations practically endorsing the British declaration. On Oct. 14 1918 the Czechoslovak National Council was constituted as a Provisional Government with all the attributes of sovereign and independent power. On Oct. 17 the Austrian Emperor Charles issued a manifesto offering the various nationalities of his empire a measure of autonomy on the basis of an Austrian federation. The offer was too partial and came too late. Austria's hour had struck. The Czechs at home declined even discussion with the Vienna Government, and declared that the question of Czechoslovakia must be left to the Peace Conference. On the 18th the Provisional Government at Paris issued a declaration of independence, signed by Prof. Masaryk, Dr. Beneš and Gen. Štefánik. On Oct. 27 the Austro-Hungarian Government recognized the rights of the Czechoslovaks, and cabled to President Wilson at Washington a request for an armistice and peace negotiations.

Thus, on Oct. 28 1918 the Czechs regained the independence which they had lost almost 300 years before, at the ill-fated battle of the White Mountain on Nov. 8 1620. The National Council at Prague issued a proclamation of independence and took over the reins of government. In spite of the presence of Austrian and Hungarian garrisons in Prague and other towns, there was no bloodshed. Every consideration was shown to the Imperial troops and the Imperial civil authorities, who were allowed to vacate their posts without being subjected to force, and the universal rejoicings of a liberated people were happily marred by no scenes of violence.

On Nov. 16 the first representative body of the Czechoslovak people—the National Assembly as it was called—met at Prague. Its members, 236 in number, were selected from all the different political parties in proportion to their strength as shown by the last parliamentary election previous to the war. The Assembly proceeded to decide upon the form of government to be adopted. The unanimous decision of the Assembly was in favour of a republic, and Prof. Masaryk, at that time still absent abroad, was unanimously chosen as first president. A Cabinet was formed, with Dr. Kramář, who during the war had been sentenced to death for treason and afterwards relieved, as premier, and Dr. Beneš as foreign minister.

Two days after the declaration of the independence of the Czechoslovak State, which had been signed also by the representatives of Slovakia, the Slovak National Council issued a "Declaration of the Slovak nation," wherein it was solemnly set forth that the Slovaks in blood, in language and civilization form part of the Czechoslovak nation. A considerable time, however, elapsed before the Slovaks were allowed without hindrance to unite fully with the Czechs. The Hungarians (Magyars) declined to surrender the territories inhabited by Slovaks, and it was necessary to call in the military help of the Czechs before the last Hungarian troops, who had initiated a reign of terror in Slovakia, could be driven out of the land.

In the extreme eastern corner of the Czechoslovak Republic, there is situated a little autonomous region of Russia (or Sub-Carpathian Russia), which, together with Slovakia, was part and parcel of the Hungarian Kingdom till the Treaty of St. Germain permitted its incorporation with Czechoslovakia. The National Central Council of the Ruthenians, which met on May 8 1919 at Užhorod, their capital, unanimously adopted a resolution approving of incorporation with Czechoslovakia, on special terms of autonomy. Thus by the express will of their people, the various lands represented in the Czechoslovak Republic, viz. Bohemia, Moravia, Silesia, Slovakia and Russia, united to form one State with a single central Government having its seat at Prague. The tasks, almost infinite in number, confronting the new State were of great gravity. The country had been brought by the Austro-Hungarian war policy to the very brink of economic and financial ruin. A starved and decimated population stood face to face with difficulties, not only on every frontier but indeed to some extent within the borders of the State itself. The spirit of courage and endurance which had enabled the Czechoslovaks to achieve their independence was now to inspire a further work of no mean significance—the consolidation of a free, democratic and enlightened republic in the heart of Europe, the most westerly outpost of the great Slavonic world stretching from the banks of the Elbe and the Danube to the Pacific Ocean, and at the same time a nation bound by ties of gratitude and common interest to the Anglo-Saxon and Latin races. "At home we feel sufficiently confident," said Dr. Kramář, the premier, at the first session of the National Assembly, "of being able to rely upon our own powers alone, and that without injustice to others. We shall count upon the devotion of all towards the State and we shall show that not only have we been able to achieve our liberty but that we know how to preserve it and to be really free—worthy of our great past, of our traditions and of our sufferings."

The National Assembly confirmed all the emergency measures which had been passed by the National Council between Oct. 28 and the date of the first session of the Assembly, such as

instance, as enactments declaring the Austro-Hungarian code of laws (with some few express exceptions) as still in force and measures securing continuity in the executive and administrative offices of State. There was thus no appreciable break in political, legal or local administration. The framing of a constitution for the new State was early proceeded with. On Feb. 29 1920, after a parliamentary committee had been at work on its provisions for almost a year, a constitution of the republic was adopted by the National Assembly.

**Constitution.**—The framers of the constitution were largely influenced by the American and French constitutions, and the American principle of the division and balance of the legislative, executive and judicial powers was followed.

The actual terms of the constitution are introduced by a preamble, which runs:—

"We, the Czechoslovak nation, desiring to consolidate the perfect unity of our people, to establish the reign of justice in the Republic, to assure the peaceful development of our native Czechoslovak land, to contribute to the common welfare of all citizens of this State and to secure the blessings of freedom to coming generations, have in our National Assembly this 29th day of February 1920 adopted the following Constitution for the Czechoslovak Republic: and in so doing we declare that it will be our endeavour to see that this Constitution together with all the laws of our land be carried out in the spirit of our history as well as in the spirit of those modern principles embodied in the idea of Self-determination, for we desire to take our place in the Family of Nations as a member at once cultured, peace-loving, democratic and progressive."

Legislative authority is exercised by two popularly elected bodies, a Chamber of Deputies of 300 and a Senate of 150 members. Of these, the Chamber of Deputies, as the more fully representative of the popular will, possesses greater powers, being enabled in certain cases to carry through its legislation in face of the opposition of the Senate. The Senate was intended to play the part of an organ of supervision, so as to act as a preventive of too hasty or too loosely drawn-up legislation. It has in more than one instance already exercised its power as a checking and restraining authority with good effects—its amendments even on substantial points having been several times accepted by the Lower Chamber.

Suffrage is universal, both men and women who have attained the age of 21 years being able to vote in elections to the House of Deputies. To vote in elections to the Senate the voter must have reached the age of twenty-six.

The president of the republic is elected in a joint session of the two Chambers. His period of office is fixed at seven years, and he may be re-elected at the end of his first term for a second period of seven years. For a third term, however, he cannot be elected until after the expiration of seven years from the conclusion of his second term of office. This restriction does not apply to the first president—President Masaryk.

The president of the republic is not answerable at law for his official acts. He may be impeached in one case only—namely, for high treason, on the motion of the Chamber of Deputies; and his only punishment, if found guilty, is the loss of his office and disability ever to hold it again. For each and all of his State acts one minister at least is responsible.

Among other outstanding terms of the constitution are the following:—The Czechoslovak State is declared to be a democratic republic with an elected president at its head. To make any alteration in its frontiers a constitutional law is required—a law which, as opposed to an ordinary law, has to be passed by a three-fifths majority of Parliament. Russia (Sub-Carpathian Russia) is granted the widest possible autonomy compatible with the integrity of the Czechoslovak Republic. The Chamber of Deputies is elected for six years, the Senate for eight. Deputies must be at least 26, senators 45 years of age. They possess immunity, but may be handed over to the ordinary courts by resolution of the House to which they belong. Parliament must sit twice a year. Declarations of war and amendments to the constitution require a vote in their favour of three-fifths of all members of both Houses. Cabinet ministers may participate in the meetings of either House and on the request of either House must attend its session.

Finance and army bills must be introduced first in the Lower House, the Chamber of Deputies. A measure passed by the Chamber of Deputies becomes law, in spite of its rejection by the Senate, if the Chamber of Deputies by a vote of the majority of its entire membership repasses the measure.

During the period when Parliament is not sitting, a permanent commission of 24 members (16 from the deputies and 8 from the senators) sits to enact urgent measures which have temporarily the force of law. They lose their validity unless confirmed within two months by the Parliament which subsequently meets.

Cabinet ministers are appointed by the president; they need not be members of either House.

In respect of civic rights no privileges of sex, birth or vocation are recognized. Titles may be conferred only when they refer to office or occupation. The liberty of the press, the right of free expression of opinion by word, writing, printed matter, etc., liberty of conscience and religious profession are guaranteed. All religious confessions are equal before the law.

All citizens of the republic are fully equal before the law and enjoy equal civil and political rights whatever be their race, language or religion; the special provisions for the protection of national and other minorities have already been referred to. The constitutional charter thus represents an honest effort to set up a truly democratic republic which shall fairly meet the demands of the varied races and religions within its borders.

**Administration and Justice.**—The executive Government is placed in charge of 15 ministries concerned with the following matters:—foreign affairs, interior, finance, commerce, labour, food supplies, railways, health, social welfare, justice, agriculture, public instruction, national defence, posts and telegraphs, and the unification of laws. The collective responsibility of this Cabinet of ministers is expressly laid down in the charter of the constitution. The president of the republic enjoys such executive power as is expressly assigned to him by the constitution, and he has his own office—the president's bureau—presided over by a permanent official, to conduct such matters as fall within his competence and to facilitate communication with the rest of the executive.

For purposes of political administration the republic has been divided into administrative subdistricts, the heads of which are appointed by and directly responsible to the central Government. Local civil government is carried on by popularly elected parish, district, urban and municipal councils.

The tribunals of the republic are the Supreme Court of Justice, which sits at Brno and is the court of final appeal both in civil and criminal causes, two high courts sitting at Prague and Brno respectively, 33 provincial courts and 410 district courts, all of which possess jurisdiction in both civil and criminal causes. Commercial cases are dealt with by the ordinary courts, except at Prague where a special commercial court sits. Litigation in mining matters is conducted before special benches attached to the district courts in mining districts. In large industrial centres there are also industrial courts to deal with disputes between employers and workpeople. At Prague there sits also an electoral court which decides upon the validity of disputed elections or forfeiture of seats and other questions relating to parliamentary or elected bodies. A constitutional court decides whether laws promulgated by Parliament are in harmony with the charter of the constitution.

Previous to 1918 the territories now composing the Czechoslovak Republic were of course subject to the Austrian or Hungarian code of laws respectively. On the collapse of the Austro-Hungarian Monarchy the Austrian code was adopted for the lands of the Bohemian crown and the Hungarian code for Slovakia. A special Ministry—that for "the unification of legislation and administrative organization"—has been entrusted with the unification of the laws for the whole republic; and two commissions of legal experts under the control of the Ministry of Justice were in 1921 at work on a careful revision of the old codes, which when completed would be issued as a uniform code for the entire republic.

**Foreign Policy.**—"Our policy," said Dr. Beneš in 1921, "is a policy of peace: in domestic affairs our programme is the logical sequel to our foreign policy, namely, social and racial order and justice, and unremitting effort on behalf of social and political democracy. The Great War must have taught us all that a calm and sensible discussion of all our differences is possible." The Czechoslovak Republic was first and foremost concerned, while avoiding all that may smack of chauvinism or imperialism, to maintain its integrity within the frontiers assigned to it by the Peace Conference. To that end it insisted upon the strict observance of the Treaties of Versailles, of St. Germain and of Trianon. It favoured an Anglo-French entente or alliance, seeing therein a substantial guarantee for the due carrying-out of those pacts. An intimate collaboration with England and France was a *conditio sine qua non* for Czechoslovakia. The creation of the so-called "Little Entente," aiming at the preser-

vation of the *status quo* in central Europe, was the primary outcome of Czechoslovak foreign policy. Czechoslovakia, Yugoslavia and Rumania became bound together in the Little Entente by a treaty of alliance (Convention with Yugoslavia dated Aug. 13 1920, with Rumania April 23 1921), positive in so far as it aimed at the establishment and maintenance of peace, security and normal economic conditions in central Europe, and defensive in so far as it was directed against all attempts at reaction menacing the existence of the new states. The efficacy of the Little Entente as a counter-reactionary alliance was manifested in April 1921, and again in October 1921, when its concerted action helped to frustrate the two attempts of Charles of Habsburg-Lorraine to recapture the throne of Hungary.

In respect of Austria Czechoslovakia was animated by the desire to assist in relieving the economic situation of the country, while opposed both to the incorporation of Austria with Germany and to the foundation of a Danubian confederation. It was in favour of aiding Austria on a broad basis of financial and economic help, to be rendered generally to the states of central Europe by international agreement. It was in favour of creating in central Europe a new political and economic system by which permanent peace would be secured—a definite understanding between all the "Succession States" of the former Austro-Hungarian monarchy in the matter of communications, post, telegraphs, navigation, finance and banking, exchange of goods and commercial treaties generally, opening up the way to a system of unfettered economics and freer trade,—but at the same time jealously guarding the economic and political sovereignty of the Czechoslovak Republic.

In respect of Hungary Czechoslovakia was at one with Yugoslavia and Rumania in holding that a Habsburg restoration would be a *casus belli*. These countries adopted the view laid down by the Paris Conference on Feb. 2 1920, which declared that "it is not within the intention nor can it be regarded as the duty of the principal Allied Powers to intervene in the internal affairs of Hungary or to dictate to the Hungarian people what form of Government or of Constitution they shall adopt: nevertheless the Powers cannot allow the restoration of the Habsburg dynasty to be regarded as a question concerning the Hungarian nation alone. They declare therefore that a restoration of this nature would be in conflict with the very basis of the peace settlement and would be neither recognized nor tolerated."

On the other hand Czechoslovakia was desirous of renewing economic and political relations with Hungary, the more so as agricultural Hungary might be regarded as the complement of industrial Czechoslovakia, supplying her with natural products and providing a market for Czechoslovak manufactures.

With Poland the relations of the Czechoslovak Republic were for a considerable time seriously troubled by the question of Teschen, both countries laying claim to that territory. The Paris Conference in July 1920 decided for the partition of the disputed area; and the decision, though it signified no small sacrifice for the Czechoslovaks and caused deep disappointment throughout the country, was accepted loyally in the hope that by this sacrifice the friendship of the Poles would be secured. In the words of Dr. Benes, "the Czechoslovak Government regards the conflict with the Poles as definitively ended and is desirous of systematically pursuing a policy of *rapprochement*." It was in this sense that the whole policy of Czechoslovakia towards Poland was directed, and the Czechoslovaks were hopeful that Poland would ultimately join with the Little Entente.

Towards Russia the policy of Czechoslovakia was logically consistent. It had always been opposed to intervention in Russia, and insisted upon Russia desisting from any act that might be construed as intermeddling in the affairs of Czechoslovakia, in particular the pursuit of Bolshevik propaganda on Czechoslovak territory. The Czechs were animated with intense sympathy for the real Russian people, and looked forward to the day when they will be able to cooperate as kinsmen in the reconstruction of a peaceful and well-ordered Russia.

In pursuance of its practical policy of *rapprochement* and economic cooperation in the reconstruction of central Europe

in particular and of Europe in general, Czechoslovakia concluded a series of commercial treaties with her various neighbours and with the Allied Powers.

**Political Parties.**—Not only was there in 1918-21 a sharp contrast in policy between the Czechoslovaks and the minority races living within the republic—the Germans and the Magyars—but each nationality was split up into a multiplicity of factions. The Czechoslovaks had 199 representatives in the House of Deputies and 103 in the Senate, and this total of 302 members was divided among no less than nine parties. The Germans and the Magyars were also proportionately split up. The strongest party in the republic was that of the Czechoslovak Social Democrats, which up to Sept. 1920 was represented by 74 deputies and 41 senators. The left wing of the party,—22 deputies and 5 senators—after a somewhat violent quarrel, then broke away and formed an independent organization owing allegiance to the Third (Moscow) International. This Communist party established its own organ, the "*Rude Právo*" (The Red Rights), in opposition to the "*Právo Lidu*" (The Rights of the People), the organ of the Social Democratic party. The Social Democrats were well organized among the industrial workers and agricultural labourers. They pursued a Marxist programme aiming at the socialization of the State, the means of production and consumption: they were opposed to a dictatorship of the proletariat, and were for evolutionary as opposed to revolutionary methods. They supported the peace policy of the Czechoslovak Government in foreign affairs, and were strongly opposed to intervention in Russia. They were also in favour of a closer cooperation with the German democratic element in the State.

The Communists aimed at a dictatorship of the proletariat, the creation of workmen's and military councils and a close hand-in-hand cooperation with Soviet Russia.

The Popular party, composed of Catholics and recruited largely from Slovakia and the country districts of Moravia, was represented by 33 deputies and 18 senators. Its organization was chiefly in the hands of the priests. It championed the rights of private ownership against Socialism, and combated the anti-Rome movement which was taking place throughout the republic. In foreign affairs it supported the Government.

The Agrarian party numbered 42 members, and published an important daily, the "*Venkov*" (Country). It was drawn from the peasant and small-farmer class, was in favour of land reform, private property rights and increased production all round. It was opposed to Socialism.

The National Socialists numbered thirty-four. They pursued a national as opposed to an international social policy, being thus opponents of the Social Democrats and in particular antagonistic to Communism. They were opposed to the Soviets, but while favouring a constitutional Russia were against any intervention in that country.

The National Democrats (Liberals), whose organ was the "*Národní Listy*," numbered twenty-nine. They were led by Dr. Kramář, and, being mostly recruited from the educated, professional and official classes, were more influential than the numbers suggest. They were strongly represented in Prague and other cities. They were, of course, opposed to Marxism and Communism. In domestic politics they were strongly Nationalist and suspicious of the Germans. They were the champions of State authority, order and public morals.

Of the German parties the strongest was again the Social Democratic party, originally numbering 31 deputies and 16 senators, but having subsequently lost three deputies who formed a German Communist party acting more or less in concert with the Czechoslovak Communists.

In 1921 the total number of Socialists of every complexion in the House of Deputies was 141, as opposed to 137 Bourgeois members (Czechoslovaks 109, Germans 72, Magyars 7). In the Senate the Socialists numbered 68, as against 75 Bourgeois members (Czechoslovaks 103, Germans 37, Magyars 3).

The composition of the Chambers sufficiently explained the fact that up to Sept. 1921 the Government of the republic had

remained in the hands of a Coalition Cabinet, or (as at the latter date) of a Cabinet composed of permanent officials supported by a coalition of parties.

**Social Legislation.**—The democratic sentiment of the Czechoslovak nation, and its maturity in social matters, resulted in the adoption of a social policy which, while proceeding without undue haste, was characterized by a comparatively rapid course of reform. Social legislation first took the form of accident and sickness insurance. In respect of the former an increase of 30% in the payments to the insured as compared with July 1 1917 was made, while at the same time better terms were given in the insurance of miners and of railwaymen; insurance against sickness was completed by extending it to agricultural and domestic workers as well as to the families of the insured. In addition to this, in the course of fixing the premiums to be paid, the amount of State support was several times increased. Sickness insurance was made to include maternity insurance. Old-age and invalidity pensions were not universal; they were made to apply, outside civil servants, to clerks and private officials only.

Pensions were also secured to the widows and orphans of the assured. A universal scheme of old-age and invalidity insurance was before Parliament in 1921. Pensions for war invalids had been granted by special enactments. Insurance against unemployment was originally introduced as an emergency measure, but the economic conditions following the war necessitated the maintenance and extension of this form of insurance, which for normal times has been given legal sanction according to the Ghent system, by State contributions to the payments made by the trade unions.

The most notable accomplishment of the young republic in the field of social-political reform has been the enactment of Dec. 19 1918 establishing an 8-hour day for industrial and agricultural workers (with some specific exceptions). Prohibitions in respect of night work, the work of women (especially mothers) and young persons have been dealt with in the sense of the resolutions adopted at international conferences.

Wages have also been the subject of legislation; special commissions have been empowered to regulate the wages in the so-called "home" industries (sweating), and an arbitration board has been appointed to fix the salaries of clerks in the metal industry, thus minimizing the danger of conflicts in respect of wages having to be settled by means of strikes.

By a far-reaching policy an attempt has been made towards solving the housing problem. A special enactment protects tenants against arbitrary treatment at the hands of landlords in respect of notice to quit and raising of rents. Numerous enactments have also been passed for the encouragement of building operations. The State grants encouragement to local authorities and to co-operative societies. These grants amounted in 1919 and 1920 to more than 62,000,000 crowns.

A vast measure of freedom, compared with their position under the Austrian régime, has been granted to women both politically and socially. Politically women are now the equals of men, and there is nothing legally to prevent a woman occupying any position in the various professions or in the administration of the State. In the two Houses of Parliament they were represented in 1921 by 16 members.

Nationalization of the coal-mines and the great industrial concerns was one of the main items on the programme of the Socialist parties. In practice moderate discussion was still proceeding in 1921 with the view of giving a more democratic character to factories and other undertakings and assuring a closer co-operation of the workers in the management. In regard to the mines specialists were in conference as to the part to be taken by the State and by public bodies in ownership and management. A first step towards demergering industrial undertakings was taken by an enactment touching mining councils. By this enactment it is made possible, where more than 20 workers are employed, for an elected council to co-operate in securing the welfare of the workers, to see to the due execution of contracts and agreements, to settle disputes, and to take part in the management of philanthropic institutions.

Another enactment assures to miners a 10% share of the net profits, this sum to be employed for educative, philanthropic, or other purposes of utility for the benefit of the miners.

On the principle of the mining councils, factory or industrial councils were projected for all industrial undertakings.

The idea underlying these councils was to create, as it were, a certain constitution for factories by which the workman who had hitherto been a mere machine should become a creative factor, closely identified with the organization of the undertaking, conscious of responsibility, and thus making of democracy the same reality in economic life as it had already become in political life.

**Land Reform.**—Long before the political revolution of 1918 the Czechoslovaks had been convinced of the necessity for a far-reaching measure of land reform, both from a social and economic point of view as well as from national considerations. Vast entailed estates were the property of a small group of landlords (in Bohemia 37.7%, in Moravia 34.4%, in Silesia 30.9% of all land belonged to owners representing 0.1% of the population), while great masses of the people did not own a single acre of their native land. The great majority of the landlords were nobles of foreign origin who acquired

their estates at the hands of the Habsburg conqueror from 1600 onwards, when, after the battle of the White Mountain, the lands of the Czech nobles and yeomen were confiscated, the owners being executed or, as adherents of the Moravian Brotherhood and other Protestant churches, preferring to pass into exile rather than surrender their faith. The demand for the nationalization of the great landed estates was thus not only supported as a social and economic necessity in order to provide the landless population, notably the legionaries, with land, but was, deep in the minds of the people, regarded as a legal rectification of the wrongs suffered through the confiscations which followed the defeat of the White Mountain.

The Act by which the great estates were sequestered was unanimously passed by the National Assembly on April 16 1919. It gives the State the right to "take" (seize) and distribute estates in so far as they exceed 150 hectares (370 ac.) of arable land or 250 hectares (617 ac.) of land of any kind. Estates belonging to the house of Habsburg-Lorraine, property illegally acquired, as well as the property of persons who during the war were guilty of gross offences against the Czechoslovak nation are taken for a compensation paid to the Reparation Commission at Vienna. In all other cases the State gives to the owner a proportionate compensation based on the average prices in the years 1913-7. For the purchase and distribution of the land a "State Land Office" has been set up. A share in the distribution may be claimed on the one hand by private persons to the amount of 15 hectares (37 ac.)—the amount suitable for cultivation by one family; on the other hand by agricultural, housing and co-operative societies. The lands taken over by the State may, of course, be used for other purposes of public utility and remain the property of the State. Even persons without means may obtain land, an enactment enabling them to purchase on credit to the extent of nine-tenths of the value of the land acquired. Special protection is given to small holders. This Land Act was to be carried out in a series of successive periods, during the first of which only estates over 5,000 hectares (12,350 ac.) would be affected.

**The Army.**—The military forces of the republic were organized immediately on the attainment of independence, on a democratic basis. The army was formed of the legionaries who had fought in Russia, France and Italy on the side of the Allies, and of those Czechoslovak troops who, on the collapse of Austria-Hungary, streamed back from the various fronts. Recruits now serve for two years, and the strength of the army is fixed at 150,000. This force, which is in essence a militia, is designed to be something different from a mere fighting machine. During their term of service the men are given not only military training but also educational advantages, as well as the opportunity of learning some handicraft. Well-organized continuation schools and systematic courses of lectures aim at providing the young soldier with a complete adult education. The Sokol societies, in collaboration with the army gymnastic clubs and with the Y.M.C.A., devote themselves systematically to the physical and moral welfare of the troops.

**Education.**—In Bohemia, Moravia and Silesia the standard of education—elementary, higher and technical—is excellent, and there are practically no illiterates—a state of affairs attributable to the interest which the Czech nation (imbued with the traditions of Comenius) had ever taken in education. In Slovakia the situation is different. The Slovaks under the Hungarian régime were kept in a backward state—they did not possess a single Slovak school—while still worse conditions prevailed in Rumania, some 75% of the population being unable to read or write. The Czechoslovak Government, between 1918 and 1921, set up some 2,000 additional elementary and some 400 higher schools in Slovakia and Rumania (including 80 new German schools), so that a vast improvement in the educational status of those countries is only a matter of time.

In the entire republic there are four universities, three Czech and Slovak—the Charles University of Prague, the Masaryk University of Brno, and the Comenius University of Bratislava—and one German (at Prague). The Masaryk and Comenius Universities are new foundations since 1918. There are four polytechnics enjoying university rank at Prague and Brno, two of them being Czech and two German. At Pflbram in Bohemia there is a high school of mines, while two other high schools have been founded at Brno, one for veterinary science and the other for agriculture.

A high standard of physical training is set by the popular gymnastic organizations, known as "Sokols." In addition to the original Sokol Society (founded in 1862) there are the special organizations of the Labour (Socialist) and the Catholic Gymnastic Unions (under Sokol influence). The great Sokol union has a membership of over 300,000 in all, and the programme includes not only physical but also moral and disciplinary training, aiming at the production of citizens of character and patriotism. The Sokol organization and the Sokol spirit were one of the mainsprings of the movement resulting, in the years 1914 to 1918, in the formation of the Czechoslovak legions on the various European battle-fronts. The "Sokol" movement, too, both for boys and girls, has since 1918 developed with much success, especially in collaboration with the other original Czech gymnastic and sport corporations.

**Religion.**—The religious history of the lands which now compose the Czechoslovak Republic has a special interest for the English-speaking world owing to the fact that the work of John Hus, the



great Czech reformer (1869-1919) was largely a result of the influence of Wyclif. At the beginning of the 17th century some 90% of the Bohemians were Protestant, but the loss of independence and the effects of religious persecution (the Counter-Reformation) under the aegis of the Habsburg dynasty, caused the position to be reversed, and up to 1918 almost 90% of the Czechoslovak population was entered in the official statistics as belonging to the Roman Catholic Church. This adherence was, and still is, often only nominal, for the statistics take no note of the great mass of indifference and liberalism which prevails in the ranks of the Church. Two other tendencies were also manifest during the last few decades before the war: a movement among the intellectual classes, and to some extent among workers also, towards a non-ecclesiastical religious life; and an "Away from Rome" movement which in one aspect helped to recruit the ranks of Free Thought and on the other hand resulted in a growth of the Protestant churches. Between 1918 and 1921 about 1,000,000 persons left the Roman Church, the most conspicuous secession being that which resulted in the formation of a national "Czechoslovak Church." A considerable section of the priesthood demanded some dogmatical reforms, including the abolition of celibacy, the introduction of the vernacular into the Church services, and a more democratic administration of Church affairs. On the Holy See declining to meet these demands the "Czechoslovak Church" was founded in Jan. 1920. It has a membership of some 500,000, and possesses 120 churches. Further large secessions took place in favour of the Free Thought movement. The Protestants number about one million, the largest body being the Evangelical Church in Slovakia with a membership of over 400,000. In Bohemia the Evangelical Church of Czech Brethren represents a spiritual and historical continuity with the old Hussites. It was constituted in 1918 by the fusion of two existing Protestant bodies, the Reformed (Calvinist) Church and the Evangelical (Lutheran) Church. Other Protestant denominations (Presbyterian, Congregational, Baptist) are in smaller numbers. The Greek Church in Slovakia and Sub-Carpathian Russia has a membership of over 500,000, while the Jews number about 350,000.

**Economics and Finance.**—The economic and financial position of Czechoslovakia showed signs in 1922 of steady recovery from the chaos which succeeded the close of the war. Rich in natural resources and peopled by an intelligent, experienced and frugal population, the country had every reason to look forward to a prosperous industrial development in the future. Without Slovakia the republic would be mainly an industrial State: with it there is a slight preponderance in favour of agriculture, 41.5% of the entire population being occupied on or in connexion with the land and 38% in industry and commerce.

In special branches of industry Czechoslovakia is pre-eminent among European countries, as for instance in the production of sugar and glass. In the manufacture of alcoholic liquors it occupies third place among European countries. It is less favourably placed in respect of the iron and textile industries, having to rely to a large extent upon the import of raw materials from abroad. The coal-mines of the country are capable of producing some 15 million tons of black coal and 24 millions of brown coal (lignite). The yield of iron ore is almost one million tons annually, while gold, silver, tin, graphite and salt are also mined. Iron and steel foundries exist at Kladno near Prague, as well as in Moravia and in Slovakia. Their blast furnaces produce 1,700,000 tons of pig-iron annually. The output of steel amounts to 298,000 tons, iron in bars 400,000 tons, iron girders 130,000 tons and sheet-iron 34,000 tons. Czechoslovakia manufactures and exports agricultural machinery, plant for sugar refineries and distilleries, locomotives, railway carriages and trucks and other rolling-stock, motor-cars, tractors. Aeroplanes are made at Prague and Pilsen (Plzeň). In its output of graphite Czechoslovakia takes second place among European countries. Great Britain being the first. Naphtha wells are working with favourable results at Gbely in Slovakia, and researches in progress at other points (Russia) promise results that would make Czechoslovakia independent of foreign sources in respect of petroleum, even if no surplus were produced for export. Potters' clay, kaolin and felspar, which have largely facilitated the development of the flourishing porcelain industry, are found in various parts of the country, which is also fortunate in possessing sand suitable for use in the manufacture of the glass for which Bohemia has long been famous.

The economic importance of Czechoslovakia is strikingly shown by a comparison with the rest of the former Austro-Hungarian Monarchy. Previous to the war the present Czechoslovak territories were responsible for 92% of the sugar produced by Austria-Hungary, for 46% of the spirits, beer 57%, malt 87%, foodstuffs 50%, chemicals 75%, metals 60%, porcelain 100%, glass 90%, cotton goods 75%, woollen goods 80%, jute 90%, leather 70%, gloves 90%, boots 75%, paper 60%. The war, of course, cut off the supply of raw materials for the textile trade, which in 1921 was still suffering from shortage, particularly of raw cotton. Czechoslovakia is the only European State which can export sugar: it is the second largest beet-sugar producer in the world, having

some 500,000 ac. of beet under cultivation. In 1920-1 some 715,000 tons of sugar were produced, 189 factories and refineries being engaged in the industry, and 300,000 tons were available for export.

Of beer 13 million hectolitres are brewed annually, of which one million are exported. Exceptionally fine hops are grown in the Zatec (Saaz) district of Bohemia, and of these no less than 40% are exported. The republic has 676 breweries and 140 malt-houses.

With an area of over 10 million ac. of forest it is only natural that Czechoslovakia exports not merely large quantities of timber but also furniture, bent-wood furniture, toys, musical instruments, etc. Of the bent-wood furniture 90% is exported and finds a ready market in England and America. Paper is also produced to the extent of some 250,000 tons annually. Of porcelain 30,000 tons is produced annually in 68 factories, Karlovy Vary (Carlsbad) being the chief centre of the pottery industry.

Glass manufacture in Bohemia dates from the 15th century. Bohemian glass enjoys a world-wide reputation, which is well deserved: the crystal ware of Bor (Haida), the imitation jewelry and stones of Jablonec (Gablonz), the paste and semi-precious stones of Turnov, are exported to every part of the globe. Over 60,000 work-people are employed in the glass industry.

Leather is among the more important manufactures of Czechoslovakia. Boot factories employ 40,000 workmen, glove manufacturers the same number. Some three-fourths of the entire output in both these wares are exported, largely to England and to Germany.

Czechoslovakia, as already indicated, is not only an industrial State: it possesses at the same time a highly developed agriculture in which over 40% of the entire population is engaged, that is to say, some 5,700,000 persons are workers in some way or other connected with the land. Climate and soil are favourable: beet-root is grown up to an altitude of 1,100 ft. and corn to 1,300 ft. above sea-level. Only 4% of all arable land in the country is unproductive (in Great Britain 15%). The chief agricultural products are potatoes and vegetables, beet-root and hops, wheat, rye, barley and oats. The agriculture of the republic supplies the material for several important industries, including the production of sugar, beer and spirits, starch (120 factories), syrup, glucose, chicory, coffee substitutes from rye and barley, jams. Alcohol and spirits are distilled in 1,100 distilleries employing 18,000 workmen and producing annually some 380,000 hectolitres (1919-20; 1,151,000 hectolitres before the war). Excellent wines are also made, those of Melnik in Bohemia and the Slovakian wines being the best known.

Agriculture is encouraged by a suitable system of education. Since it came into being the republic had by 1921 founded 13 new agricultural schools, and in all there were 186 agricultural and forestry schools (higher and elementary), including the so-called "winter schools," while more than 50 periodicals appeared regularly for the technical instruction of those engaged in agriculture. The agricultural interests were also represented directly in the Parliament by a strong Agrarian party.

The foreign trade of Czechoslovakia was in 1921 growing steadily in volume. Previous to the war the country's products were, of course, classed as Austrian goods: now the description of "Made in Czechoslovakia" was beginning to make its way in the markets of the world. In 1919 the republic exported merchandise to the extent of 566 million tons and imported 183 millions. In 1920 these figures rose to 690 and 200 million tons respectively. In 1919 Czechoslovak exports to Great Britain (exclusive of colonies) amounted to a value of 238 million crowns, imports to 328 millions. Sugar, malt, hops, beer, mineral waters, glass, porcelain, leather, gloves, furniture and toys are the principal articles of export to Great Britain.

While suffering from the symptoms affecting central Europe generally, the republic was distinctly better off as regards its financial situation than any of its neighbours. The budgets of 1919 and 1920 disclosed deficits of 5 billion and 3 billion kronen respectively, but in that for 1921 the revenue slightly exceeded the expenditure. Czechoslovakia was thus the only country in central Europe with a well-balanced budget. The national debt amounted to some 90 billion crowns, against which the State itself possessed assets in the shape of forests, coal mines, the former domains of the Habsburgs, mineral, naphtha, radium and other sources of natural wealth, besides the State-owned railways.

**Communications.**—As a wholly inland nation, Czechoslovakia has to rely in the matter of transport upon its railways and its waterways, notably the Elbe, which connects the republic with Hamburg and the North Sea, and the Danube, which unites it with the east of Europe and the Balkans. Under the peace treaties Czechoslovakia acquired her own docks and warehouses in the harbour of Hamburg. Before the war the Czechoslovak traffic on the Elbe totalled some 4 million tons annually. On the Danube the amount was 2 millions, but this total bids fair, under normal conditions, to be easily passed, inasmuch as the work of developing the port of Bratislava, the construction of docks, warehouses and shipbuilding yards, was already proceeding energetically. It was also proposed to link up the Elbe and the Danube by a canal which would enable direct transport to be effected from North and Baltic Seas to the Black Sea. A further scheme in contemplation was that of a Danube-Oder canal.

The total length of railway track in Czechoslovakia was in 1921 a little over 8,000 mi., which represents 1 mi. of railway for every 83 sq. mi. of area. In the course of a few years the mileage was to be



largely increased, Parliament having voted some 6,500 million crowns for further construction and improvements. Some 4,700 m. of track are State-owned; the rest are in the hands of private companies, but were gradually to be taken over by the State.

Czechoslovakia has 5,000 post-offices, some 10,000 m. of telegraphs, and close upon 8,000 m. of telephone communication. Aerial posts are established with Paris, Warsaw, Berlin, Vienna and Budapest, in addition to which there exist also cross-country services. The republic possesses seven radio-telegraph stations.

**Literature, Art and Music.**—The Czechs have possessed a notable literature from the 13th century onwards. It has shared the vicissitudes of the nation itself and like it been in danger of extermination at the hands of fanatic foes. The names of Hus, Chelický and Comenius (Komenský) are connected with the pre-Renaissance religious periods. The revival of the Czechs after a hundred years of torpor, due to the loss of their independence in 1620 and subsequent oppression at the hands of the Habsburgs and the dominant Germans, gave birth, from 1780 onwards, to a literary activity which still continues to yield rich fruit. From the modest and simple art of the patriotic poets and novelists of the first half of the 19th century, whose work nevertheless was an influential factor in the awakening of a national sentiment among the common people, Czech literature, after a period characterized by the romanticism of Mácha and the critical realism of Havlíček, arrived at a school which, while it took its inspiration from the sources of the national spirit, did not shut itself out from foreign influences. Vrchlický, a master of verse and a perfect cosmopolitan, and Čech, who took the material for his epics from Czech history, are the outstanding names of this epoch. Among their contemporaries were Heyduk and Sládek, two poets both belonging in form and in matter to the national school. Sládek was, with his excellent translations, one of the first to make Czech readers acquainted with the riches of English literature (especially Shakespeare). Eminent among the novelists of this generation were Němcová, a good observer of social conditions who reproduced in her works the charm of Bohemian peasant life; her kinswoman Světlá, Arbes and Zeyer. Neruda, a poet of bitter irony but of profound faith in and affection towards his nation, was also the author of novels, notable for their original realism, and numerous belletristic works of a high order. He marks the period of transition to the younger generation of writers, in the forefront of whom stands the poet and novelist Hachar, who revolutionized the conception of Czech patriotism and is famous for his historical glosses. Jirásek, the author of a vast series of novels and short stories, drawing their material from Bohemian history, unites the past with the present generation. By the healthy spirit of patriotism breathed in all his works Jirásek contributed not a little to maintaining among the masses of the people a national consciousness and faith in a better national future. The youngest literary generation in Czechoslovakia was represented in 1921 in particular by three leading poets: Sova, a writer of delicate lyrics; Bezruč, who sings of social and national oppression, and Březina, a profound visionary and pantheistic mystic. Among prose writers the leading contemporary names are Svobodová, Capek, a robust realist, and Srámek, who has also met with success as a dramatist. In Slovakia the foremost name is that of the poet Hviezdoslav.

The Czechs were famous as musicians as far back as the 15th century. The history of modern Czech music commences with the creator of Czech opera, Frederik Smetana. The compositions of Dvořák have become classics. Among contemporary composers in 1921 the foremost were Foerster, Novák, Ostrčil, and Suk; and as executants Ševčík, Kubelík and Ondříček.

Eloquent testimony is given by the beautiful churches and palaces of Prague—largely Gothic and baroque in style—to the architectural genius of the nation. The graceful cathedral of St. Vitus, rising above the castle (*Hrad*) on the heights of the Hradčany (Prague), is a magnificent specimen of Gothic. The beautiful church of St. Barbara at Kutná Hora, the royal castle of Karlův Týn, the Powder Tower, the church of St. Nicholas, the King Charles bridge at Prague, are among the many objects of universal admiration which are to be found in Bohemia.

Of modern sculptors the works of Myslbek and Sucharda are prominent in the public monuments at Prague. The latter, as well as others of the younger school of Czech sculptors, such as Bílek, Kafka and Mařátka, studied under Rodin at Paris.

Modern painting among the Czechs begins with Josef Mánes (1826-71) and Czermak (1831-78), and Alcs. Brožík is known for his historical canvases, among them "John Hus before the Council of Constance," while others worth mention are the marine painter Knopfer, the landscape painters Slavíček and Hudeček, and Preisler and Svabinský as painters of portraits and allegorical subjects. Mucha has won a name abroad for decorative work and historical canvases. In Slovakia, Joža Uprka and his school have devoted themselves to interpreting peasant life.

**Science and Philosophy.**—In the course of the new intellectual life, by which after three hundred years of subjection the Czech nation again entered the ranks of the living peoples of Europe, scientific effort early resumed its due place.

At the very threshold of the Czech renaissance men of science were among the first pioneers of national thought, as for example Dobrovský the philologist, and in the ensuing generation Purkyně

(Purkinje) the physiologist, and Palacký the greatest of Czech historians. Scientific effort received an impetus from the establishment of an independent Czech university at Prague in 1881, and from that time there is hardly a branch of science in which workers of profound and creative talent did not arise (in physics Zenger, in biology Vejvodský), while a whole series of eminent names as well in the technical and mathematical as in the historical and philological (e.g. Zbátary) sciences might be mentioned.

Philosophy was early cultivated in Bohemia. At first the influence of German thought, German enlightenment and idealism was apparent, particularly in Kollár (a Slovak); the influence of Kant was seen in Palacký, that of Hegel and post-Kantian speculation in Aug. Smetana, while the philosophy of Herbart had a deep influence on educationists like Lindner, Durdík and Hostinsky. To the more recent tendencies of contemporary philosophical thought the way was opened up by Thomas G. Masaryk, who, as a counterpoise to German speculation and the intellectualism of Herbart, emphasized the critical study of English philosophy, notably Hume, Spencer and Mill, and the French Comte; at the same time he fully appreciated the value of Kant in epistemology. Masaryk's work, *Spirit of Russia*, is a close analysis of the Russian philosophy of history, and of the Russian religious, moral and political thought. Enriched by new ethical and religious elements, Czech philosophy manifests itself in Masaryk's works as a new realism or humanism. A whole series of philosophic thinkers—Drtina, Foustka, Rádl and Benes—followed in Masaryk's footsteps.

**BIBLIOGRAPHY.**—W. F. Bailey, *The Slavs of the War Zone* (1916); E. Benes, *Bohemia's Case for Independence* (1916, with an introduction by H. Wickham-Steed); *Détruisez l'Autriche-Hongrie* (1916); Besteaus, *Bibliographie Tchèque* (1920); Alex. Brož, *The First Year of the Czechoslovak Republic* (1920); *The Rise of the Czechoslovak Republic* (1919); Cisar, Pokorný, Selver, *The Czechoslovak Republic* (1921); T. Capek, *Bohemia under Habsburg Misrule* (1915); *The Bohemian Biography* (1918); Dědeček, *La Tchecoslovaquie et la Tchecoslovaquie* (1919); Louis Eisenmann, *La Tchecoslovaquie, sa carte hors texte* (1921); Etienne Fournel, *De la Succession d'Autriche* (1918); Hoetzl and Joachim, *The Constitution of the Czechoslovak Republic* (1920); D. Jurkovič, *Slovakische Volksarbeiten* (1919); T. G. Masaryk, *The New Europe* (1918); *The Problem of Small Nations in the European Crisis* (Council for the Study of International Relations 1916); B. Matejka and Z. Wirth, *L'Art littéraire contemporain* (1920); W. S. Monroe, *Bohemia and the Czechs* (1910); Vl. Nosek, *Independent Bohemia* (1918); C. Pergler, *The Czechoslovak State* (1919); C. Rivet, *Les Tchecoslovaques* (4th ed., 1921); P. Selver, *Anthology of Modern Bohemian Poetry* (1912); R. W. Seton-Watson, *German Slav and Magyar* (1916); *The Czechoslovak Republic* (1921); E. Stern, *La Législation ouvrière tchecoslovaque* (1921); J. E. S. Vojan, *Modern Musical History of Bohemia* (1917); Weiss, *La République Tchecoslovaque* (1919). (T. G. M.)

**CZERNIN, OTTOKAR, COUNT (1872- )**, Austro-Hungarian statesman, a scion of an old Bohemian noble family, was born on Sept. 27 1872. He adopted a diplomatic career, was attached in 1891 to the Paris embassy, promoted to the rank of unpaid attaché of embassy, and then, after a lengthy period of leave, sent to The Hague in 1902. In that year, however, he retired and devoted himself to the management of his estates. In 1903 he was elected to the Bohemian Diet as a representative of the landed aristocracy. Here he attached himself to the German party, but demanded that every inhabitant of Bohemia should regard himself as an Austrian first, and only second as a German or a Czech. Connected by his wife, née Kinsky, with the Czech nobility, he tried to pave the way for a working alliance of the great landowners supporting the existing Constitution with the Conservative group in the Bohemian Diet, and in 1905 published a brochure with this object. In 1911 he published a signed essay on the measures to be taken to preserve the union of the empire (*Zur Erhaltung der Reichseinheit*), which represented the views of the heir to the throne, the Archduke Francis Ferdinand, with whom he had become intimate. In Feb. 1912 he became a member of the Austrian Upper House, attaching himself to the Constitutional party. His speeches, in which he advocated a vigorous internal and external policy, made a great sensation. Czernin at that time was regarded as Francis Ferdinand's candidate for the office of Foreign Minister. In Oct. he went as Austro-Hungarian minister to Bucharest. His dispatches published in the "Red Book" show that even at that time he was of opinion that the secret treaty signed by King Charles with the Triple Alliance was nothing but a "scrap of paper," and that in an international war Rumania would only be induced to take part on the side of the Central Powers by far-reaching concessions at the expense of the Habsburg Monarchy. He watched with regret the growth

of anti-Austrian sentiment in Rumania, whose attitude after the outbreak of the World War proved the correctness of his judgment. He now sought even at a cost to win over Rumania to fight on the side of the Central Powers. But his efforts proved fruitless, because the leading Hungarian statesmen would not agree to Rumanian demands involving the cession of Hungarian territory. For a long time Czernin succeeded in persuading Rumania to remain neutral. When, at the end of 1916, she finally passed over into the Entente camp Czernin returned to Vienna. The foresight which he had shown as minister at Bucharest, the skill and zeal displayed in his intercourse with the Rumanian court and Government, and his good personal relations with influential circles at Bucharest, decided the Emperor Charles to entrust him with the direction of Austro-Hungarian foreign policy in succession to Count Burian.

Czernin was, and remained, a decided advocate of the view that the Central Powers could not obtain so crushing a victory over the enemy in the field as to be able to dictate the conditions of peace. Therefore, from the day of his taking office down to his resignation he consistently maintained that, even at some sacrifice, they ought to seek the conclusion of a peace which should preserve to them their position as great Powers. Czernin did not indeed contemplate the conclusion of a separate peace with the enemy, but as against German statesmen he insisted that Germany also, especially in the questions of Belgium and Alsace-Lorraine, would have to reconcile herself to concessions. By gloomily painted pictures of the military, political and economic situation of Austria-Hungary he sought to influence the German Emperor and the German higher command, and succeeded in awakening sympathy with his peace ideas among the members of the German Reichstag. Czernin was not only cognizant of the peace negotiations which the Emperor Charles opened with England and France through his brother-in-law, Prince Sixtus of Parma, but he approved of them. He knew nothing, however, of the contents of the letter of March 24, 1917, in which the Emperor Charles spoke of his willingness to support the "just demand" of France for the return of Alsace-Lorraine by

any means and by the use of his whole personal influence with his ally. But he himself was simultaneously engaged in trying to influence German statesmen in the same sense, promising in the event of their making sacrifices in the west to compensate them in the east, chiefly by the acquisition of Polish territory. But his efforts, then and later, broke down on the determination of the German army leaders to obtain a military decision. These men saw in Czernin a danger to the political and military interests of the Alliance, and attacked him violently. During the negotiations at Brest-Litovsk from Dec. 1917 to March 1918, the opposition between the views of the Austro-Hungarian delegation led by Czernin and the German delegation became strikingly manifest. In the negotiations leading up to the convention between Russia and the Quadruple Alliance, signed on March 4, 1918, Czernin took a conspicuous part. A few weeks earlier peace had been concluded at Brest-Litovsk with the newly founded republic of the Ukraine. The fact that Czernin, in order to secure this "bread peace," had ceded to Ukraine the district of Chelm, to which the Poles laid claim; aroused the most violent resentment among the Poles, and led to unsparing attacks upon him by the Austrian Poles. In the beginning of April 1918 his position was no longer tenable. The immediate cause of his resignation on April 14, 1918, was the conflict between him and the Emperor Charles over the "Sixtus letter." Czernin was one of the few active statesmen among the Austrian nobility who sought to continue their political activity under the Austrian Republic. At the end of 1920 he became the representative of the Liberal bourgeois party of central Vienna in the National Parliament.

For Czernin's activity in Bucharest and in the World War see his *Im Weltkrieg* (1919). His despatches from Bucharest are printed in the Austro-Hungarian Red Book, *Diplomatische Aktenstücke betreffend die Beziehungen Oesterreich-Ungarns zu Rumänien, 22 Juli 1914 bis 27 August 1916*. A favourable view of Czernin's attitude in the "Sixtus Affair" is taken by Count August Demblin in *Czernin und die Sixtusaffäre* (1920); the standpoint of Prince Sixtus is represented in *Prince Sixt de Bourbon. L'offre de la paix séparée de l'Autriche* (1921). (A. F. PR.)

**D'ABERNON, EDGAR VINCENT, 1ST BARON** (1857— ), English politician, was born at Slinfold, Sussex, Aug. 19 1857, the youngest son of Sir Frederick Vincent, 11th Bart., of Stoke d'Abernon, Surrey. He was educated at Eton, and was intended for the diplomatic service, being in 1877 head of the examination list for the appointment of student dragoman at Constantinople. The same year, however, he entered the army, but in 1880 was appointed private secretary to Lord Edmond Fitzmaurice, at that time commissioner for Eastern Rumelia. The following year he became a member of the commission for the evacuation of territory ceded to Greece by Turkey, and in 1882 was sent to Constantinople as the representative of Great Britain, Holland and Belgium on the council of the Ottoman public debt, of which in 1883 he became president. In 1883 he was sent to Cairo as financial adviser to the Egyptian Government, remaining there until 1889, when he returned to Constantinople as governor of the Imperial Ottoman Bank, a post which he resigned in 1897. In 1887 he received the K.C.M.G. Sir Edgar Vincent entered Parliament in 1899 as Conservative member for Exeter, but lost this seat in 1906. He unsuccessfully contested Colchester in 1910. In 1914 he was raised to the peerage as Baron D'Abernon, and became very prominent during the World War as chairman of the Central Liquor Control Board. In 1920 he was appointed ambassador to Germany. Lord D'Abernon published in 1881 a *Grammar of Modern Greek*, which was adopted for use by the University of Athens. He married in 1890 Lady Helen Venetia Duncombe, daughter of the 1st Earl of Feversham.

**DAH, JULIUS SOPHUS FELIX** (1834—1912), German historian, jurist and poet (see 7.734), published his complete works of fiction, both in prose and verse, in 1903. The final volume of *Die Könige der Germanen* appeared in 1911. He died at Breslau Jan. 3 1912.

**DAHOMÉY** (see 7.734).—An estimate made in 1918 put the population at slightly over 900,000, of whom 65% lived in the coast and adjacent regions. Upper Dahomey, two-thirds in area of the whole colony, has no more than 12 inhabitants per sq. m., compared with 50 per sq. m. in Lower Dahomey. Porto Novo (seat of Government and chief business centre) had about 25,000 inhabitants, including some 400 Europeans. Whydah and Abomey each had a population of 12,000 odd. In all there were over 700 Europeans in Dahomey. There are large numbers of mulattoes in the coast towns, chiefly employed as clerks.

*Trade and Communications.*—The French devoted much attention to the development of the natural resources of the country and in opening communications. The metre gauge railway from Kotonou (the ocean port of Porto Novo) which runs parallel to the Nigerian frontier reached Savé, 162 m. inland, in 1912. Thence a metalled road (nearly 300 m. long), with substantial bridges was built to the Niger at Madekaki, just W. of the British (Nigerian) frontier. Along this *Route de l'Est* a motor wagon service for passengers, mails and goods was opened in 1912. From Pahu, 16 m. from Kotonou, a branch line (20 m. long) runs W. to Whydah and Segboroué. The line from Porto Novo to Saketa, near the Nigerian border, was in 1914 extended to Pobé (total length 47 m.). On the Togoland side there is a good metalled road connecting with the middle Niger regions. In the coast region a mail steamer service was opened in 1912 along the lagoons between Porto Novo and Lagos.

Cocoa plantations were largely developed from 1912, and the coconut palm—for the copra trade—introduced in the lagoon districts, while in central Dahomey cotton plantations met with success. Maize is largely grown for export, and there are considerable herds of cattle in the north. But palm oil remains the chief source of wealth of the country; oil palms cover about 600,000 ac. The volume of trade increased during 1905—12 from £1,075,000 to £2,530,000. The trade for 1916 was valued at £1,446,000; in 1918 at £2,332,000 (evenly distributed between imports and exports). The increase in 1918 was largely due to higher prices. Palm kernels and palm oil are the chief exports; maize, cotton, dried fish, copra, shea nuts and shea butter rank next in value. Cotton goods, gin and trade spirits are the chief imports.

Before the war Hamburg took nearly all the palm kernels; during and since the war the kernels have gone mainly to Liverpool. In 1913 Germany had 49.28% of the total trade, France 26.47; the

United Kingdom 23.74; the elimination of Germany told mostly in favour of the United Kingdom. The colony is self-supporting; in 1919 the budget balanced at £237,000. Nearly half the revenue is derived from a poll tax on the natives.

*History.*—In 1911 the French deposed the chief, a member of the old royal family, whom they had installed at Abomey. He had been intriguing against French rule. His territory was divided among a number of petty chiefs placed under the direct control of the resident at Abomey, and the whole country became the colony of Dahomey and its dependencies. From that time little trouble was experienced in the native administration. In Sept. 1912 a Franco-German convention approved the delimitation of the Dahomey-Togoland frontier which had been made by boundary commissions. Less than two years later, on the outbreak of the World War (Aug. 1914), small columns of French troops entered Togoland and cooperated with the British in its conquest. The energetic action of M. C. Noufflard (the Lt.-Gov.) and of Commandant Marioux (senior military officer) and Capt. Coستاing helped to bring the conflict to a speedy close and to keep Dahomey itself peaceful. The natives of Dahomey furnished contingents for the Cameroon campaign and for Europe.

See *Dahomey* (1920), a useful handbook issued by the British Foreign Office; A. Le Hérisse, *L'Ancien royaume du Dahomey* (1911); P. Sprigade, "Die französische Kolonie Dahomey" in *Die deutschen Schutzgebiete* (1918); *L'Afrique Française* (Paris, monthly). (F. R. C.)

**DAIL EIREANN:** see IRELAND, section *Political History*.

**DAMOSCH, WALTER JOHANNES** (1862— ), American musician and conductor, was born at Breslau, Germany, Jan. 30 1862. He came to America in 1871 and ten years later began his career as conductor in Newark, N.J. In 1894 he founded the Damosch Opera Co. for producing Wagner. In 1896 he produced, as director of the Oratorio Symphony Societies, Wagner's *Parsifal* in concert form for the first time in the United States. Since 1903 he has been director of the New York Symphony Orchestra. He is the composer of *The Scarlet Letter* (1894); *Cyran* (1913); and music for Euripides's *Medea*, *Iphigenia in Tauris* (Berkeley, 1915) and Sophocles's *Electra* (New York, 1917). At the request of Gen. Pershing he reorganized the bands of the A.E.F. in 1918.

His brother, FRANK HEINO DAMOSCH, was born at Breslau June 22 1859. He was conductor in Denver, Newark, Bridgeport, and New York (the Oratorio Society 1898—1912). From 1905 he was director of the Institute of Musical Art.

**DANCING** (see 7.794).—The years 1910—20 saw a remarkable revival of the love of all kinds of dancing in England and America. On the one hand the organization popularly known as the Russian Ballet has put new life into stage dancing, while on the other the Americans are responsible for a reawakening of the love of dancing in the ballroom. At the end of the 19th century the ballet in England had become a spectacular show of very little artistic significance; the standard of dancing technique was of the lowest and, except in the case of one or two dancers such as Adeline Geneé, it is doubtful whether stage dancing could be called an art at all. In the ballroom, dancing had become a rather perfunctory social function, practised without any particular skill or regard for steps.

*Classical Dancing.*—The revolution in stage dancing was started in England by Serge Diaghileff's company of Russian dancers, but no account of modern stage dancing would be complete without some reference to the so-called "Classical Dancing" which came into vogue at the beginning of the 20th century and had such an influence on all the stage dancing of a later date. Classical dancing was a revolt against the form and style of the stage ballet as it then existed. It was an attempt to rescue the art from the artificiality of the older ballet, and bring beauty of line and movement into prominence, instead of the technical skill of the steps alone. In addition to this, classical

dancers laid stress upon the musical side; they sought to interpret the great composers in dancing; values of Chopin, Mendelssohn's "Spring Song," some of the smaller works of Schubert—all these were "interpreted" in different ways. The dancers sought to catch the mood of each piece of music by an appropriate series of poses and movements, which were intended to be not only expressive of the music but beautiful in themselves. The costume worn was a simple dress in the Greek style, with the feet bare; the strangeness of this costume at the time and the similarity of many of the poses to Greek paintings and friezes led to the use of the word "classical" for this dancing.

The first and greatest exponent of this particular school was Isadora Duncan. Her own point of view with regard to stage dancing is worthy of mention:—

"In my art I have by no means copied, as has been supposed, the figures of Greek vases, friezes, and paintings. From them I have learned to regard nature, and when certain of my movements recall gestures that are seen in works of art it is only because, like them, they are drawn from the grand natural source."

This description epitomizes the whole of the theory of classical dancing, and Isadora Duncan's numerous successors improved very little either on her own theory or practice. Her technique was of her own invention and, although the result looked simple and easy enough, the training to which she subjected herself was severe. Perfect balance, perfect transition from one pose to another however slowly, perfect control of breathing and movement, all these, she found, required as much practice and study as the older style of ballet dancing. There was nothing impromptu, nothing amateurish in her work. The result was entirely novel and at first was received with ridicule both in Europe and America; it was only much later that she achieved the success and received the praise which were her due. She danced on the stage by herself without scenery and with only a simple background of curtains which showed off the movements to their best advantage and kept the concentration of the audience on the dancer only.

It was left to one of Isadora Duncan's successors, Maud Allan (b. 1879), to popularize classical dancing in England. Her strongest quality was the very interesting way in which she interpreted musical phrases and moods. The early musical training she had in Berlin accounted no doubt for this fascinating quality.

The influence of classical dancing on the stage dancing of a later date is very considerable. The ballet which was designed by Nijinsky to the music of "L'Après-midi d'un Faune" of Debussy, and which was danced by him with picked members of Diaghileff's *corps de ballet*, would never have been possible without Isadora Duncan, and her dancing undoubtedly had a great influence in bringing stage dancing back into relation with real life and away from the absurd artificiality of the 19th century stage ballet.

The "Russian Ballets."—England hardly had time to recover from the revolutionary methods of Isadora Duncan and Maud Allan when there appeared a new organization which was acclaimed with rapturous applause and enthusiasm, first of all by the artistic world of London and very shortly afterwards, at their bidding, by the general public. Serge Diaghileff was responsible for the introduction of this company and was the moving spirit in collecting together the various people who contributed to this highly artistic and successful enterprise. He it was who enlisted the services of Léon Bakst and Alexandre Benois, the designers of the scenery and costumes; Michel Fokine, the producer and arranger of the dances; Nicholas Tcherepnin, the musical director; and the leading dancers, Karsavina, Anna Pavlova, Lydia Lopokova, Vaslav Nijinsky, Adolph Bolm, Léon Massine and Enrico Cecchetti.

The success of this company not only in London but all over the world—they visited all the principal towns of Europe and America—was all the more unexpected because very few people in England were aware that anything so perfect could come out of Russia. The existence of the Imperial Court ballet at St. Petersburg was dimly known, and it was thought, at first, quite

wrongly, that Diaghileff's company had some connexion with it. So far from this being the case it can truthfully be said that the connoisseurs of dancing in St. Petersburg had no great opinion of Diaghileff's productions and achievements. The Imperial Russian Ballet was instituted in 1735 and continued up to the revolution and the Tsar's deposition in 1917. The high standard of technique of the Imperial Ballet was very largely due to Didelot, a ballet master of the early 19th century at St. Petersburg, but Diaghileff's troupe was a very revolutionary body, and had very little in common in idea with the Imperial Ballet. True, the *corps de ballet* and dancers of the "Russian Ballet" were trained in the Imperial schools, and Fokine was the assistant ballet master at the St. Petersburg opera, but Bakst and Tcherepnin had no connexion whatever with the Imperial Ballet. The classical ballets performed by the Imperial Ballet at St. Petersburg year after year did not as a rule form part of Diaghileff's repertoire. His outlook on stage dancing differed as much from the official ideas in Russia as those of Isadora Duncan from John Tiller. His aim, like Miss Duncan's, was to bring the ballet into relation with real life and the contemporary arts which go to make up the "production."

The ballets themselves can be divided broadly into two classes; those which are the lineal descendants of earlier ballets, and those which are essentially experiments in new directions. Into the first category fall such ballets as "Lac des Cygnes," "Pavillon d'Armide," "Cléopâtre," "Thamar," "Oiseau de Feu," "Petrouchka," the dances from "Prince Igor," and "Sylphides." With regard to the last-named an interesting point was the use of Chopin's music, orchestrated by well-known Russian composers. This orchestration of what was hitherto considered as essentially piano-music created quite a sensation, and was one of the most successful efforts of the Diaghileff company. The vivid colour schemes of the scenery and dresses, and the modernity of some of the music (as in "Petrouchka"), were as much responsible for the effect of vitality and realness as the standard of the choreography and dancing, which were in themselves higher than any hitherto seen in England. Apart from the setting however, the characterization of the various personages in these ballets was presented in such a way as to make the stage people seem alive and convincing to the audience, every device of stage-craft and orchestration being used to this end.

With regard to the second category of ballets, "L'Après-midi d'un Faune" was an attempt that was only partially successful to bring the plastic arts of Greece on to the stage. "Le Sacre du Printemps" was a return to the "primitive," in the artistic sense. For both these, Nijinsky was mainly responsible as producer, and Stravinsky's music to the latter ballet was furiously "modern" into the bargain. It is doubtful whether these last-mentioned productions or any of the still later ballets, however interesting as experiments, were as satisfying artistically or theatrically perfect as the early ones of Fokine and Bakst. "The Good-Humoured Ladies" and other clever little scenes, charming in themselves, have not gone much further aesthetically, and in 1920 the standard of the dancing and the performance of the music were not on quite so high a level as in the first years of production.

Ballroom Dancing.—In the ballroom a different kind of revolution has been effected by the introduction of new dances and music from America. The only dance that has survived this invasion is the valse, but even this dance has altered so much in style that it now bears very little resemblance to the dance immortalized by Edward and Johann Strauss. The dances in common use (1921) are the fox-trot, one-step and the valse; the one-step is the most energetic of all the modern dances, owing to the clearly defined beats of the music, which is in quick march-time; the fox-trot is the lineal descendant of the polka, although the steps are not the same, and it is danced more smoothly, without the jerkiness of its ancestor. The steps are legion and ever changing with the style of the dancers. There are only three or four steps which are used by all couples and consequently make it possible for a man to dance with a new partner

for the first time. The woman's part in these dances is absolute passivity; she has to follow the man's lead and be responsive to his lightest touch. Every good dancer is now an adept at this, and the variety of steps in common use is surprising.

The evolution of the valse from mid-Victorian days is worthy of note. At the beginning of the 20th century, for some reason which is quite obscure, the tendency of dance bands was to play the valse faster every year than the last. The result of this was that the valse, which was then by far the most popular dance, instead of being slow in time, became a series of fast revolutions. Dancers refused, in consequence, to continue to perform what one may call the one-two-three circular rhythm of the valse at the accelerated pace; they found the solution of the problem was to dance the same steps at a slower rate in cross rhythm against the music. Various other steps were added to enable these couples to manoeuvre successfully among the old-fashioned dancers. These new steps became crystallized, others were added, and the result was finally taught as the "Boston."

The popularity of the "Boston" was short-lived owing to the difficulty of the performance in cross rhythm, and the congestion of traffic in the ballroom on account of the different speeds of the revolving couples. As soon as the new American dances obtained a hold in England the latitude in steps so essential to the new dances was extended to the old valse. The tempo of the music slowed down to its original speed and the "Boston" disappeared. Valses were played more slowly and the latitude of steps was the same as in the other dances. The old one-two-three step has very largely gone, and the difference between a valse and a fox-trot is mostly one of rhythm. The modern valse was called the "Hesitation" as opposed to the earlier "Boston."

The "Tango" was the result of an attempt on the part of dancing teachers to introduce a new dance into the ballroom about the year 1913. It came originally from America and is said to be founded on a dance used in the cafés of South America, which would account for its somewhat "Spanish" style; the rhythm of the music is akin to that of the "Habaneña." The most remarkable feature of all the dances described above as opposed to the dances of earlier generations is that the personality of the dancers is clearly reflected by the steps they use.

The music of the modern ballroom is almost entirely supplied by the United States. The music used in the American dances is no longer a string band and piano, but consists of various combinations, the most common of which perhaps is—piano, violin, alto or tenor saxophone, banjo and jazz-drum. This last-named needs some explanation. The word "jazz" signifies noise in America and is in no way a dance. The drummer uses a side drum, a big drum and cymbals played with the feet, and various other instruments on which he beats a tattoo with his drum-sticks in alternation with the side drum. He is in fact a sort of one-man band in himself and adds considerably to the rhythm of the ensemble. There is as much variety in the method of playing dance music to-day as in the dances themselves. Dance bands therefore vary considerably in skill, as might be expected, and the best known command very high salaries. The skill of a modern dance band lies in two essentials: first, good rhythm; and secondly, cleverness in extemporising variations on the tune by the different executors.

The effect of the American dances has not yet permeated the social scale, and the masses among whom dancing has always been a popular pastime, and they continue to prefer the dances of the 19th century.

(G. T. \*)

**DANIELS, JOSEPHUS** (1862— ), U.S. politician, was born at Washington, N.C., May 18 1862. He studied at the Wilson (N.C.) Institute and at the age of 18 became editor of the *Wilson Advance*. He was admitted to the bar in 1885, but preferred newspaper work, becoming editor of the *Raleigh State Chronicle*. He was printer for the state of North Carolina from 1887 to 1893, and then for two years, under President Cleveland's administration, was chief clerk of the Department of the Interior. From 1904 he was editor of the *Raleigh News and Observer*, with which his former paper was consolidated. He was twice a delegate to the National Democratic Convention, and from 1896 to

1916 was a member of the Democratic National Executive Committee. He early became a supporter of Woodrow Wilson for the presidency and was publicity manager for his campaign in 1912. In 1913 he was appointed Secretary of the Navy by President Wilson. In 1914 he issued an order prohibiting the use of intoxicants on ship-board and within the limits of navy yards and stations. His personal interest in the enlisted men was shown by his provision of opportunities for training in various trades. From the first he advocated increase of the navy. During his first years as Secretary of the Navy he was much criticized, but after America's entrance into the World War the criticism died down. He favoured Government ownership of armour plate plants as well as of telephones and telegraphs. On retiring from the secretaryship of the Navy in 1921 he resumed his duties as editor of his newspaper. He was the author of *The Navy and the Nation* (1919).

**DANKL, VIKTOR, FREIHERR VON** (1854— ), Austro-Hungarian general, was born in Udine. After service in the cavalry he was employed in important staff positions. In the World War he commanded at the outset the I. Army and defeated the Russians in the battle of Krasnik (Aug. 23-5 1914). After the Italian declaration of war he became in May 1915 commander of the defence forces in Tirol. As an army commander in the following years he took a successful part in the offensive against Asiago-Asiero, but shortly afterwards retired from his post on account of ill-health.

**D'ANNUNZIO, GABRIELE** (1863— ), Italian poet, man of letters and soldier (see 2.78). Later years, from 1908 to 1921, were the most active in D'Annunzio's career, not only in the literary field but also in those of war and politics. In 1908 he produced *La nave*, a vivid presentation of the early history of Venice, in which he sets forth his aspirations for Italy's mission as a great sea power, mistress of the Adriatic—a curious forecast of his future political action. The following year *Fedra* appeared, a classical drama, and in 1911 *La martyre de St. Sébastien*, a dramatic mystery play written by D'Annunzio in French verse and first performed in Paris, with musical interludes by Debussy; it was a remarkable tour de force and appreciated as such by French critics, but is hardly one of his greatest achievements. *La Pisanella, ou la mort parfumée* (1913), also written in French and first produced in Paris, is a picturesque reconstruction of the mediæval Levant set forth in the author's gorgeous colouring. The same year he brought out in Paris *Chère-fouille*, a drama of modern life, with a plot adapted from Hamlet and containing some powerful scenes, and in 1914 he produced a slightly different Italian version of it entitled *Il ferro*. *Parisina*, a lyric tragedy in a Renaissance setting with music by Mascagni, was first performed at Milan, also in 1914. His attraction towards the stage did not wholly suspend his output in the field of fiction, and in 1911 he published *Forse che sì, forse che no*, a powerful but somewhat long-winded novel in which aviation plays a considerable part, and in 1913 *La Leda senza cigno*, a collection of pieces, half essays and half fiction, which originally appeared in the *Corriere della Sera* and were afterwards issued in three volumes with a license in 1917. His purely poetic output was limited to the *Canzoni della gesta d'Ortamaro* (1911), dealing with the Libyan war and containing some admirable verse, and also some violent invectives against the Powers which were hampering Italy in her Mediterranean policy.

The outbreak of the World War did not put an end to D'Annunzio's literary activity. For some years he had been living in France, having had to leave Italy on account of financial difficulties, but the moment the conflict began he became deeply impressed with the vital necessity for Italy to participate in it so as to realize her aspirations towards complete unity and affirm her sovereignty in the Adriatic. His addresses to the Italian people, full of eloquent and inspiring patriotism, were afterwards published in a volume *Per la più grande Italia*. In the spring of 1915 he returned to Italy; his speeches at Quarto for the celebration of Garibaldi's Sicilian expedition and in Rome aroused wide-spread enthusiasm, and undoubtedly contributed very largely to Italy's intervention. From the moment Italy declared

was D'Annunzio's career became one of the extraordinary romances of modern times—the man, hitherto regarded as a sensuous aesthete and a decadent, whose only claim to distinction was his exquisite sense of beauty and his mastery of the language, was now to prove a man of action, a soldier of almost incredible bravery, and a politician who, however his conduct may be regarded, for many months monopolized the attention of the world, and defied powerful Governments.

Although 35 years old, he at once volunteered for active service. Having been a reserve cavalry officer in the Novara Lancers he first joined the cavalry; but as that arm seemed at the time to have little chance of fighting, he got himself attached to the 77th Infantry and spent many months in the Carso trenches, always in the most exposed positions. But even that was not enough for his exuberant spirit, and he soon joined the navy headquarters in Venice, whence he took part in many torpedo and submarine raids. Finally he took to flying, in the hope of achieving immortality even at the cost of his life. His exploits in the air were of the most fantastic nature, and he became an airman of the very first rank. In one of his flights he lost an eye, in another was wounded in the wrist, and many times his airplane was riddled with bullets. In Aug. 1918 he led a flight over Vienna, where no bombs were dropped, but only propaganda pamphlets as it was an unfortified city; the exploit was particularly audacious owing to the great distance over enemy country which had to be covered. He obtained three special promotions for gallantry, attaining the rank of lieutenant-colonel, was decorated with one gold medal for valour (a distinction corresponding to the V.C.), four silver and two bronze medals, and was created officer of the Military Order of Savoy. On being demobilized in June 1919 he received an exceptionally flattering letter from the Chief of the General Staff, regretting that the mobilized army should lose his valuable assistance, adding that he would still remain "spiritually among us," as a brilliant example "for the whole army of faith, heroism and self sacrifice." During the first period of the war he published 10 war poems, some of them of great beauty, and after Caporetto he delivered several eloquent addresses collected in *La Riscossa*; on the Buccari enterprise he wrote *La beffa di Buicari*.

After the conclusion of the Armistice the cold attitude of the Allied Powers, and especially of President Wilson, towards Italy, aroused D'Annunzio's bitter indignation, and his letters and articles in this connexion, collected in the volume *Contro uno e contro tutti*, will occupy a prominent place in the literature of invective. The extreme violence of his language contributed not a little to embitter the relations between Italy and President Wilson. During the Nitti régime D'Annunzio came to personify the patriotic reaction against the Government's policy; while he became the idol of a small body of enthusiasts, he attracted the sympathies of an ever-increasing portion of all the best elements in the country. The Fiume dispute symbolized in his mind the whole conflict between Italy's aspirations and the selfish greed and ingratitude of her Allies. When, in consequence of the decision of the commission of inquiry into the anti-French riots at Fiume, the Italian garrison was to be greatly reduced and the town policed by Maltese gendarmes, a movement was planned by Major Reina of the Granatieri brigade to reoccupy the town in the name of Italy with regular troops and volunteers. D'Annunzio accepted the leadership of the expedition and on the night of Sept. 11-2 he marched from Ronchi at the head of detachments of grenadiers and other troops and reentered Fiume. The movement was vehemently disapproved by the Italian Government, and D'Annunzio was severely criticized even by many of his admirers for having tampered with the discipline of the army and navy at such a critical moment, even for a patriotic purpose. On the other hand the policy of Signor Nitti and the open hostility of the Allies justified in the eyes of a large part of Italian opinion even so desperate an action. For 15 months D'Annunzio defied the Italian Government and indeed the whole of Europe with success. He assumed the style of ruler or "Commandant" of Fiume and created a new State. His "reign" was character-

ized by a picturesque mysticism, with Italian patriotism as the first article of his creed, and numbers of enthusiastic young, and indeed middle aged, men flocked to his standard from all parts of Italy. Men like Gen. Ceccherini, one of the bravest soldiers in the Italian army, Maffeo Pantaleoni, the eminent economist, and the syndicalist leader De Ambris came to Fiume and loyally served under the "Commandant," and many officers of the army and navy also joined him; the archaeologist Giacomo Boni, the poets Siciliani, Fucini and Orvieto, the aged Risorgimento patriot Senator Di Prampero, the scientist Prof. Cian, Senator Del Lungo the distinguished man of letters, to mention only a few, openly expressed their approval of his action. His position at Fiume ended by going to his head, and his language and actions came to be ever fuller of rhodomontade, verging at times on the ridiculous, while the adventurous nature of his undertaking also attracted many undesirable characters, not all of them Italians, who gradually acquired influence over him and egged him on to blameworthy actions. In his opposition to the official attitude of Italy he came to regard its Government, even after Nitti had fallen, the army itself, except the small part of it which had followed him, and indeed the whole Italian people outside Fiume, as enemies, and on them he poured the vials of his wrath and eloquence, hitherto reserved for foreign Powers. When the Rapallo treaty was concluded he refused to recognize it, as he disapproved of its provisions regarding Fiume and Dalmatia, and his refusal to submit, while causing serious difficulties to the Government, alienated from him the sympathies of many who had approved his action at first and who strongly criticized the treaty. The Government was finally obliged to resort to force in order to carry out the Rapallo treaty, and D'Annunzio after vowing to hold Fiume to the bitter end, submitted in Jan. 1921, and left the city. He then went to live at Gardone on the lake of Garda. During his stay at Fiume he delivered innumerable speeches, addresses and messages, all of a high-flown and exaggerated style, but full of his usual passionate eloquence. Most of these were printed on fly-leaves and in newspapers; a small part of them were collected in two pamphlets *Italia o morte* (1919) and *Italia e vita* (1920). His constitution of the *Reggenza del Carnaro* is a strange mixture of poetic concepts and mediæval law. His diplomatic correspondence with the Italian Government, published by him in a "Green Book," also belongs to the domain of literature.

DANZIG (Polish Gdansk) (see 7.824), a free city constituted in accordance with the provisions of the Treaty of Versailles on Nov. 15 1920. The confines of the territory, extending over some 1,800 sq. km., were laid down by Article 100, the delimitation of the frontier being entrusted to a commission composed of three members appointed by the principal Allied and Associated Powers, one appointed by Germany and one by Poland. The area of the free city, as well as the adjoining Polish territory—formerly part of West Prussia—now divides East Prussia from the rest of Germany.

The pop. of the city in 1910 was 182,468, that of the entire free city territory being some 300,000. The river is navigable from the sea entrance at Neufahrwasser to a distance of 4 m. for ships drawing 27 ft. and for a further 2 m. up the river Mottlau for vessels of about 15 ft. draught. Facilities are available for the repair and maintenance of ships. Up to 5,800 tons these can be accommodated in floating docks of which there are several. There are four dockyards, viz. Schichau, Danziger Werft (formerly Imperial dockyard), Klawitter and Wogan. Schichau yard has built vessels of 35,000 tons. The Imperial dockyard was largely used during the World War for submarine construction, besides being a repair centre for torpedo craft and a constructional centre for aircraft. The present annual building output of 20,000 tons could be largely increased. The free basin has a wharfrage of about 3,600 ft., and vessels drawing from 18 to 24 ft. can lie alongside. Electric cranes and warehouse accommodation are provided and railway connexion exists with the main system. The island of Holm (an important adjunct to the port) has a partially completed basin of great potential value as a commercial harbour. The rifle factory furnished some 1,600 rifles a day during the war, employing 10,000 men and being supplied with the most modern machinery. After the Treaty of Versailles came into force it devoted itself chiefly to the manufacture of domestic articles, the personnel being greatly reduced.

The chief imports are raw materials for manufacture, clothing



and foodstuffs. The principal exports are timber and sugar. Large granaries and warehouses for sugar stand near the wharves of the port, which also affords storage capacity for over 20,000 tons of oil. Timber pens are at Holm I. and extend for several miles along the bank of the Dead Vistula between Danzig and Pishendorf.

The port has great commercial possibilities, the natural features of the waterways and surrounding country rendering expansion easy. The port is practically ice-free and is the only gateway to Poland. Thanks largely to the protection afforded by the peninsula of Hela, it has special advantages of security and development. The river Vistula from its source in the Carpathian mountains to its mouth at Schiewenhorst in the gulf of Danzig is 660 m. in length. Harmonious coöperation between the free city and Poland, resulting in security and the capital required for the expansion and development of the port, is essential to assure a prosperous future for the city and a corresponding benefit to Poland.

A constitution was drawn up in 1920 by duly elected representatives of the free city in agreement with the High Commissioner appointed by the League of Nations. This constitution was placed under the guarantee of the League of Nations and the free city was proclaimed on Nov. 15 1920. A treaty between the free city of Danzig and the Polish republic, negotiated by the principal Allied and Associated Powers (Article 104 of the Treaty of Versailles), came into force at the same time. By the Danzig constitution the Legislature is composed of a senate and a popular assembly. The senate consists of a president (who is the chief officer of the state), a vice-president, and 20 senators. The popular assembly consists of 120 deputies, elected by the universal, equal, direct and secret vote of all citizens, both men and women, who have attained the age of 20 years, in accordance with the principles of proportional representation. The League of Nations reserves the right of inviting the free city to introduce amendments to the constitution.

By the Treaty of Versailles Poland received the unrestricted use of the port, Polish imports and exports passing freely. The free city and Poland now form one customs area under the Polish customs tariff and legislation. The control and administration of the railway system within the free city (except that specially serving the port) and of direct communication between Danzig and Poland, as well as postal, telegraphic and telephonic communication via the port of Danzig between Poland and foreign countries, is given to Poland. German nationals ordinarily resident in the territory of the free city lost their German nationality on the coming into force of the Treaty and became nationals of the free city of Danzig. A diplomatic representative of the Polish Government stationed at Danzig acts as intermediary between the Polish Government and that of the free city. Poland undertakes the conduct of the foreign relations of the free city as well as the protection of its citizens abroad. Passports issued to nationals of Danzig require the visa of the representative of Poland in Danzig. The right to fly the Danzig merchant flag is restricted to ships owned exclusively by nationals of the free city. The Danzig port and waterways are under a board composed of an equal number (not exceeding five) of Danzig and Polish commissioners. Its president is of Swiss nationality, failing previous agreement between the Danzig and Polish Governments.

<sup>1</sup> Of special interest to the British visitor may be mentioned the so-called "Englisches Haus," rebuilt in 1569 as a home for the London cloth merchants on the site of their former house; evidences of early communication between Great Britain and Danzig may be found in the "Englischer Damm" and in the quarters of the town still known as "Old Scotland" and "New Scotland." The High Commissioner appointed by the League of Nations occupies the residence of the former commander of the German troops.

<sup>2</sup> See P. Simson, *Geschichte der Stadt Danzig*, vols. 1, 2 and 4, 1913; W. Lutostawski, *Gdańsk and East Prussia* (1919); A. Choloniewski, *Danzig, ville polonaise* (1919); *Les sièges de Danzig et l'occupation française 1807-1813 par le Général Brouelley*, (1904); Erwin Stein, *Monographien deutscher Städte, Danzig*, Band VI. (1914); Simon Askenazy, *Danzig and Poland* (1919); Treaty of Peace signed at Versailles on June 28 1919, Documents published by the League of Nations.

**DARDANELLES CAMPAIGN, 1915.**—The Dardanelles campaign of 1915 was brought about by a desire entertained during the early stages of the World War by the Allied Governments, and especially by the British Government, that communications

should be opened up from the Mediterranean into the Black Sea. These communications had been severed on the Ottoman Empire throwing its lot in with the Central Powers three months after the commencement of the struggle. Russia had in consequence been virtually cut off from intercourse by water with the outer world, seeing that the Baltic likewise was closed owing to action of the German navy; no adequate outlet for the Russian Empire's produce remained available; the most promising avenue for the introduction of warlike stores into the Tsar's dominions from without had been effectually barred. The very fact of reestablishing this vital strategical and economic artery of the Near East by force of arms would, moreover, of necessity carry with it the occupation of Constantinople by Entente forces and would deal a resounding blow at the very heart of the Sultan's realms. There was furthermore, at the juncture when the project of attack upon the Dardanelles was first seriously mooted at the beginning of Jan. 1915, a special inducement offered to the Allies for acting in this quarter—any threat to Stambul and the Golden Horn must tend to take pressure off the Russian army in Armenia which was at the moment believed to be in some peril.

War between Turkey and the Allies broke out at the end of Oct. 1914, following on several weeks of strained relations due to the reception of the German warships "Goeben" and "Breslau" within the Straits. Some British vessels carried out a brief bombardment of the Ottoman batteries at the mouth of the Dardanelles on Nov. 3, but the operation partook merely of the nature of a reconnaissance, and for some time hostilities were confined to a blockade of the Ottoman coasts,<sup>1</sup> defensive steps in Egypt, and the seizure of the Shat el Arab and Basrah.



To secure command of the maritime defile that links the Aegean with the Sea of Marmora was, in the opinion of most

<sup>1</sup> On Dec. 13 1914 the British submarine B11, Lt. Norman Holbrook, successfully passed the mine-fields of the Straits and torpedoed the old Turkish battleship "Messudieh" at anchor. Less fortunate, the French submarine "Saphir" was sunk in a similar attempt to penetrate the inner waters on Jan. 15 1915.

authorities, an almost indispensable preliminary to the undertaking of warlike operations against Constantinople and the Bosphorus by fighting forces coming from the west. The question of the mastering of this all-important lower waterway in the event of a contest with the Turks had indeed engaged the close attention of British naval and military experts some years earlier. The conclusion arrived at on that occasion had, however, been that, whether the campaign were to take the form of a purely naval operation or whether the task were to be performed by an amphibious expeditionary force, the enterprise was bound to prove most difficult. In 1914 the channel was known to be defended by a number of batteries, some of them armed with very heavy guns. Most of these works were planted about the slender reach situated about 10 m. above the outlet into the Aegean, and known as the "Narrows." If the batteries and their artillery were somewhat out of date, the fact remained that warships steaming up the defile would be compelled to pass these fortifications at very close quarters, when the lack of range of their guns would cease to tell. The Ottoman authorities were moreover known to have given much attention to the problem of mine-fields especially adapted to the peculiar conditions existing within the Dardanelles; and the development which had taken place in this particular form of defence was such as to render the task of a fleet which should try to force the passage a more difficult one than it would have been a few years earlier. The fact that along the whole of its course this remarkable waterway is only separated from the Aegean by the attenuated Gallipoli Peninsula, did, on the other hand, suggest that the most promising method of attack upon the maritime defile from without would be to occupy that significant tongue of land.

An appeal reached the British Government from Russia on Jan. 2 1915 for help to relieve the existing situation in Armenia, and an operation directed against the Dardanelles was judged to be the best means of complying with the request; but there were no large bodies of troops available that could be used for such a purpose. The consequence was that the feasibility of forcing a way from the Mediterranean up into the Sea of Marmora as a purely naval undertaking came to be examined afresh in London. When asked for his views, Vice-Adm. Sir Sackville Carden, the British commander-in-chief in those waters, proposed that a fleet should try to destroy the Ottoman forts in the Straits and to clear away the mine-fields sown in the channel, by adopting a process of methodical advance. This plan possessed the merit of novelty. It had always been assumed during previous discussions on the question that warships adventuring the passage would try a rush, that they would endeavour to steam by the batteries and drive the defending gunners from their guns by concentrated fire. Although the professional chiefs at the Admiralty were not enthusiastic supporters of Adm. Carden's project, the Government decided to adopt it.<sup>1</sup> French concurrence was obtained, French support was promised, and measures were at once set on foot to concentrate such naval forces in the Aegean as appeared to be required for the execution of the plan.

A considerable armada was got together, although its assembling took several weeks and although the Russians had as a matter of fact heavily defeated the Turks in Armenia (battle of Sarikamish) even before orders for the assembling were issued. As regards large craft, the fleet consisted in the main of semi-obsolete battleships looked upon as unfit to take part in a fleet action. Of such ships the British contributed fourteen<sup>2</sup> and the French four.<sup>3</sup> But the fleet also included two semi-dreadnoughts ("Lord Nelson," "Agamemnon"), the battleship "Inflexible" and the newly completed "Queen Elizabeth,"

<sup>1</sup> On the naval operations, see also the article NAVAL HISTORY OF THE WAR.

<sup>2</sup> "Queen," "London," "Prince of Wales," "Implacable" and "Irresistible"; "Majestic" and "Prince George"; "Cornwallis" (Duncan class); "Swiftsure" and "Triumph"; "Vengeance," "Abdon," "Goliath" and "Ocean" (Canopus class); For the characteristics of these ships and of the "Lord Nelson" and "Inflexible" see 24-89.

<sup>3</sup> "Bouvet," "Suffren," "Charlemagne," "Gaulois."

armed with 15-in. guns. The battleships were to be aided by several cruisers and destroyers and a flotilla of mine-sweepers was also organized. The conveniently situated islands of Tenedos and Lemnos<sup>4</sup> (the latter offering the immense land-locked haven of Mudros as an anchorage) were occupied to serve as naval bases, and on Feb. 19 the venture opened with an attack upon the weakly Ottoman batteries that guarded the outlet of the channel. The batteries were silenced for the time being; but bad weather interrupted the proceedings, and the batteries had to be silenced afresh a week later (Feb. 25)—effectually on this occasion. That night the mine-fields at the mouth of the Dardanelles were cleared away, and battleships were in consequence enabled to penetrate into the lowest reaches of the defile on the morrow.

Stormy weather caused some delays in continuing the programme, but heavily armed vessels made their way a short distance up channel on several days early in March and engaged some of the enemy works that were sited about the Narrows.<sup>5</sup> The sweepers continued their labours night after night, gradually extending the fairway up which heavy craft could safely venture. Long-range fire on the forts directed from outside the Straits over the Gallipoli Peninsula was also tried, but the results proved disappointing. In reality, a very liberal expenditure of artillery ammunition on the part of the fleet was doing considerably less damage to the Ottoman defences than the Allied sailors imagined to be the case. Any Turkish battery that was chosen for target generally ceased firing before long; and the assailants were disposed to assume that the work was definitely put out of action, whereas all that had happened in reality was that the hostile gunners had been driven from their guns. Moreover, promising as the situation may have appeared to be from the attacking side in so far as neutralization of the Ottoman batteries was concerned, it was plain that the mine-sweepers were making disappointing progress. The enemy's light guns, aided by effective searchlights, were offering a strenuous opposition to the small craft engaged on the all-important duty of clearing the channel of submerged defences. At last Vice-Adm. Sir John Michael De Robeck, who had succeeded Adm. Carden, decided, under some pressure from home, to undertake an onset in full force upon the defences of the Narrows by day, although mine-fields still forbade a close attack on the forts on the part of battleships.

This operation took place on March 18, and it proved unsuccessful. Sixteen battleships entered the Straits to participate in the encounter, the manoeuvring of so large a number of great vessels in this narrow space was a matter of some difficulty and also gave excellent targets for the Turkish artillery, which replied to their fire with unexpected spirit. The contest lasted for several hours, but towards evening the fleet was obliged to retire, three of the battleships having been sunk and four others having been put out of action. The three vessels lost, the "Irresistible," "Ocean" and "Bouvet," were out of date; but of those put out of action the "Inflexible" was a modern ship, and she and another very nearly foundered before they could be got to a place of safety. The defenders employed mines drifting down with the current with striking success on this occasion, and the damage caused by them contributed largely to bring about the defeat of the naval force. The events of the day indeed clearly indicated that the enemy's underwater devices were an even more serious obstacle to the forcing of the Dardanelles than were the Ottoman batteries. Nor had the Allies grounds for supposing that drift-mines would not be met with, were the attack renewed.

After this experience Vice-Adm. De Robeck felt himself obliged to inform the Admiralty that the offensive against the Straits ought not to be continued as a purely naval operation of war. This necessitated a complete recasting of the Entente plans. The Turkish authorities, it may be mentioned,

<sup>4</sup> Lemnos was a Greek possession having been ceded to Greece as the result of the Balkan War of 1912-3. Imbros, Samothrace and Tenedos had remained Turkish.

<sup>5</sup> On March 10 Bulair was also bombarded from the Gulf of Saros.

on finding nearly all the ammunition for their heaviest ordnance in the Narrows to be used up, viewed the prospect of a possible fresh fleet attack with some apprehension, as they were under the impression that the assailants had been beaten off on the 18th by the guns and not by the mines. This led to a mistaken idea that De Robeck's ships might have succeeded had they renewed their attack at once in spite of losses; the damage which they had done to the batteries had been almost insignificant, and they had not got within 5 m. of their objective.

The Allies had foreseen from the outset that land forces would have to be brought into play sooner or later in their campaign in this region. Even assuming that the fleet forced the Dardanelles, its communications would have to be safeguarded, and there would still be Constantinople and the Bosphorus to be dealt with. Entente troops had already before March 18 been set in motion for the Aegean, and some were in Lemnos. A heterogeneous army, drawn largely from India and Australasia, had also been gathering in Egypt for several weeks past, of which portions could be made available for work elsewhere in the Near East. Gen. Sir Ian Hamilton, who had been chosen as commander-in-chief of the military contingents that were to co-operate in due course with the naval forces in this theatre of war, had moreover actually arrived on the day before the abortive fleet attack upon the Narrows and had witnessed the fight. In view of what had occurred the Allied Governments decided that in further operations full use must be made of the gathering army, and from this time onwards the military began to assume the principal rôle in the effort of the Entente to secure command of the Dardanelles.

But Sir Ian Hamilton judged it to be inexpedient to initiate land operations at once. Reconnaissance had brought to light the extent to which the Turks were making preparations to repel attempted landings, both on the Gallipoli Peninsula, and on the Asiatic coast adjacent to the mouth of the Straits; and everything pointed to the expeditionary force having to start work by fighting its way ashore. A tactical operation of that character demanded most careful prior organization, and it called for a distribution of the attacking force amongst the available shipping based on purely tactical considerations. As a preliminary to his undertaking a serious land campaign on the shores of the Aegean, the general felt himself obliged to concentrate his forces in Egypt, and to prepare them there for the hazardous undertaking to which they were to be committed. A month was lost in consequence.<sup>1</sup> During that month the Turkish V. Army was formed (March 24) to guard the Straits, and Marshal Liman von Sanders, head of the German military mission in Turkey, was appointed its commander-in-chief. Between the last days of March and the day of the landing the defence system was overhauled and greatly developed.<sup>2</sup>

The Franco-British expeditionary force was to be composed of seven divisions—three, the 20th, the 42nd and the Royal Naval, furnished by the United Kingdom, two formed of Australian and New Zealand troops, and two composed of French colonial troops. At the time however when active operations began the 42nd Division and one of the French divisions could

<sup>1</sup> The chief naval incidents of this month were:—a raid by the Turkish destroyer "Demir Hissar" which sank the British transport "Manitou" on March 16, but had to be blown up next day off Chios to avoid capture; an attempt of the British submarine E15 to enter the Straits, which led to her being forced ashore (April 16) and in the sequel to her destruction by a daring boat's crew from the "Majestic" (April 18); bombardments of the defences of Smyrna on March 28, April 6 and April 22; and operations at Gaza and El Arish on the Syrian coast by the French battleship "St. Louis" and other vessels (April 12-17).

<sup>2</sup> From the Black Sea the Russian naval forces bombarded the Bosphorus defences on March 28; some fruitless operations were then carried out against the "Goeben" and "Breslau" (in the course of which the Turkish cruiser "Medjidieh" was sunk off Odessa (April 3), and on April 25, the day of the landing in the Peninsula, and on May 2, the Bosphorus defences were again shelled.

<sup>3</sup> The coast defences themselves remained under the command of the German Adml. v. Uedom, who was also responsible for those of the Bosphorus. The German naval forces were commanded by Adml. Souchon, who had brought the "Goeben" and "Breslau."

not be counted on owing to shipping for them not being available. Against this force Liman von Sanders could bring the outset six divisions. Hamilton had resolved on making the Gallipoli Peninsula his objective, intending to secure high ground which dominated the Narrows from that side. He could conceal his design up to the very last. His adversary had perforce to disperse the defending troops, so that on the morning when the land campaign started two of the Turkish divisions (3rd and 11th) were watching the outer coast on the Asiatic side, two (5th and 7th) were near Bulair to provide against a landing at the neck of the Peninsula, while the remaining two (9th and 10th) under Essad Pasha guarded the places where, in the event, the Allied army made its appearance. Still, if the attacking side enjoyed an advantage in this respect, the possible landing-places were few in number and were therefore well indicated, there had been ample time to protect them with earthworks and barbed wire, and in any disembarkation in face of resistance the tactical conditions favour the defence.

Hamilton contemplated two distinct major operations. One force was to be put ashore about the extremity of the peninsula—an area which it is convenient to designate as "Helles." The other force was to land N. of Gaba Tepe, where there are extensive beaches. Part of the one available French division was, furthermore, to effect a descent at Kam Kale opposite Helles as a subsidiary operation, partly to deceive the enemy and partly to neutralize Turkish guns, which otherwise might intervene in the Helles fighting. Feints were also to be carried out at other localities so as to bewilder the defenders. The effort at Helles was to be entrusted to the 29th Division, supported by the Royal Naval Division, and ultimately to be reinforced by the French division. That at Gaba Tepe was to be carried out by the two Australasian divisions under Gen. Sir William Birdwood. The Anglo-French army concentrated in Mudros Bay, the great natural harbour of Lemnos, in the third week of April and, after a short delay enforced by bad weather, the armada put to sea during the nights of the 23rd-24th and the 24th-25th, so that the transports and the covering warships should arrive at the various rendezvous at or before dawn on the 25th. The day broke calm and still, after a placid night.

A firm footing was gained on shore by the assailants at three out of the five points where disembarkation was attempted, while the effort was also, within restricted limits, successful at the two remaining points. The beaches which had been selected were, enumerating from right to left, "S" in Morto Bay, "V" and "W" on either side of Cape Helles at the south-western end, and "X" and "Y" on the outer shore; "V" and "W" were regarded as of primary importance, as those two beaches offered suitable landing places from the point of view of subsequent operations. The attacks at "S" and "Y" were intended to be subsidiary; but great importance was attached to that at "X" owing to the vicinity of this point to "W." The troops started for the shore in flotillas of boats soon after dawn at all points, their approach covered by the fire of battleships and cruisers, and in all cases the boats were not fired upon until almost the last moment.

As it turned out, the actual disembarkations at "S," "X" and "Y" were carried out without any very great difficulty; but the troops detailed for "W" beach only gained a footing after incurring very heavy losses and by a display of indomitable resolution, while at "V" the operation went very near to failing altogether. In the general scheme of attack the landing at this last point was of primary importance; the largest force had been detailed for it, and the troops were for the most part conveyed to the beach in a steamer (the "River Clyde") which was run ashore, but only some scattered detachments covering close to the water's edge had established themselves on land by nightfall, and the Allies' position here seemed to be highly critical. The troops detailed for "Y" beach had also got into serious difficulties, and as it turned out they had to be withdrawn next morning. But the forces which had landed at "W" and "X" beaches had joined hands, the one battalion detailed for "S" beach had secured a good position, and during the night the troops still

left aboard the "River Clyde" contrived to disembark. The resistance offered by the Turks had been most determined, and these could reckon upon receiving welcome reinforcements within a few hours; for as soon as the situation declared itself Liman von Sanders had hurried off one of the two divisions (the 7th) at Bulair by water with orders to repair to Helles.

In the meantime a French brigade had, after a tough struggle, effected a lodgment at Kum Kale. The Turks were in strong force in that quarter, and, as the hours passed and the defenders (3rd and 11th Divs.) massed, the situation became such as to render any French advance out of the question; indeed, but for the fire of the warships the troops who had landed could barely have maintained themselves. Still, their presence on the Asiatic side of the Straits was for the time being indirectly helpful to their British comrades who were struggling for a grip on the extremity of the Gallipoli Peninsula.

The invaders of Helles had secured but a precarious foothold on Ottoman soil by the morning of the 26th, twenty-four hours after starting operations; but fair progress was made by them during the course of this second day. What was left of the force originally detailed for the landing at "V" beach contrived during the early hours by stern fighting to occupy some high ground hard by, and also to join hands with the troops landed at "W" beach. Additional infantry was got ashore at "W" and "X" beaches, the first elements of the French division began disembarking at "V" beach in the afternoon, and before evening touch had been gained with the battalion that had made good at "S" beach. That night the French evacuated Kum Kale by arrangement. On the 27th a general move forward took place, the Turks (9th Div.) offering little opposition, and by nightfall the Allies held a line stretching approximately from the north end of Morto Bay to "Gully" beach. But very heavy losses had been sustained by the 29th Division, large bodies of Turkish troops had arrived from Bulair and were being brought round from the Asiatic side of the Straits,<sup>1</sup> and after three days of strenuous combat the British and French had barely secured a depth of 2 m. of country, while their opponents had had time to concentrate their scattered forces. Realizing the urgent need of gaining ground before the enemy was gathered in full strength, and hoping to win the heights beyond Krithia and Achi Baba, Sir I. Hamilton ordered a further attack for the 28th. On this occasion the Turks made a determined resistance; but the Allies' line was advanced by a few hundred yards at most points, and a three days' lull then ensued in the Helles area.

While this embittered struggle had been in progress at the extremity of the peninsula, stirring events had been in progress on its outer coast-line. The arrangements for disembarking Birdwood's Australasians differed from those made at Helles, in that here the whole force was to land at one point, and that an attempt was to be made to effect a surprise just before dawn (April 25). The surprise was effected, but in the darkness the force arrived at a locality about a mile N. of the beach immediately N. of Gaba Tepe which had been the selected goal. The beach on which the landing took place proved to be satisfactory, but it lay at the foot of a steep and rugged declivity, which was therefore a most unsuitable place for putting ashore the stores and impeding an army. At the moment of approach of the first boats the defenders actually on the spot were few, so that the high ground overhanging the landing place (which came to be known as Anzac Cove) was secured by the assailants at the first rush. But the enemy speedily brought effective flanking artillery fire to bear on the beach and on the boats; the troops, both officers and men, were inexperienced, the ground to be advanced over was hilly, scrub-clad and extremely broken, and considerable confusion arose. The advantage gained in the first instance by the surprise was lost, and the Turkish 19th Div. was able to gather in force during the critical hours of

the morning when the Australasians might, in virtue of their superior numbers, have secured a satisfactory sector of ground. At the end of the day, although the whole of Birdwood's infantry had been ashore for several hours, the position which these troops had taken up remained a haphazard one, no depth had been secured, losses had been heavy, and the situation seemed so threatening that the question of a withdrawal was even considered at one time.

Reinforced by parts of the two Bulair divisions the Turks delivered vigorous counter-attacks on the 26th; but these were beaten off, and on that day and on the morrow the Australasian troops dug themselves in so thoroughly that by the night of the 27th-28th the position which they had taken up, such as it was, was reasonably secure. On the other hand, the Turks, who were commanded by Essad, had likewise dug themselves in, and they could bring an effective artillery fire to bear on the Anzac trenches from three sides, the prospect of the landing force making any effective progress under the awkward conditions of ground in which it found itself was remote, and Birdwood's contingents had in reality been even less successful than had those detailed for Helles as regards securing an adequate area on the enemy's shores before the defence gathered strength. Their situation was unsatisfactory not only in the tactical sense, but also from the point of view of keeping the troops supplied, owing to their being perched on ridges with steep gradients behind them. Water also was found to be scarce, and was sure to become scarce during the summer months. Lastly, the landing place was much exposed in the event of bad weather.

Although his adversaries had fought their way ashore in two sections of the Gallipoli Peninsula—and he had had to give up his first idea of driving them back to their ships—Liman von Sanders had no grounds for despondency when May opened. The Allies' plan was now unmistakably indicated, and concentration of the defending forces had become possible in consequence. The marshal's Turks had fought gallantly in the strenuous encounters which had taken place, and large reinforcements (2nd, 4th, 13th, 15th, 16th Divisions) were on the move or preparing to move to his aid. His troops were entrenching themselves solidly in face of the invaders both at Helles and at Anzac, so that his antagonists would be obliged to storm lines of earthworks whenever they should attempt to make further progress. It is true that Hamilton was expecting the arrival of the 42nd Division and of the 2nd French Division within a few days; but his losses had been extremely heavy, there were no depôts at hand from which these losses could promptly be made good, and he was inferior to the Turks in artillery both as regards calibre of guns and as regards ammunition. On three successive nights from the 1st to the 3rd the Turks delivered resolute assaults upon the Allies' position at Helles, but they were repulsed on each occasion; they also on the night of the 2nd-3rd launched attacks upon the Australasians, the combat lasting into the next day, but here also they were beaten off.

Two brigades of Birdwood's force were thereupon temporarily transferred to Helles by night, and on the 6th and following two days a mighty effort was made by the invaders to push forward in this southern area and to win the high ground that stretches across the peninsula about 5 m. from its extremity; their front was, however, only advanced by a few hundred yards and a much more pronounced success was called for to render the Allies' position in this area at all a promising one. Much work was done in organizing the area and its communications and landing places, but the tactical situation at Helles remained stationary for the rest of the month. At Anzac similar work was done; but the only tactical incident of much importance in that quarter was that Liman von Sanders personally directed a formidable attack upon Birdwood on the night of the 18th-19th, the assailants being defeated with severe loss.

The arrival of German submarines<sup>2</sup> during this month proved

<sup>1</sup> The German commander of the 3th Div. (Lt.-Col. v. Sodenstern) was put in charge of the Helles front, Essad taking command on the Ari Burnei front.

<sup>2</sup> The abbreviated designation of the "Austrian and New Zealand Army Corps."

<sup>2</sup> Already a special German submarine command had been established in the Adriatic, with bases at Pola and Cattaro, and some small boats were sent thither by rail. Two of these (UB1, UB15) were attached to the Austrian submarine force. Three

to be an event of lasting importance. Two British battleships were sunk off the peninsula ("Triumph" May 25, "Majestic" May 27), and owing to the risks run by warships and transports while in the open the Allied troops on shore were thenceforward almost deprived of support from naval gunfire, while reinforcements and stores were mostly brought from Mudros to the various landing places in small craft. Hamilton made Imbros his headquarters, and troops also were sometimes collected there owing to its vicinity both to Helles and to Anzac. Within the Dardanelles the battleship "Goliath" had been torpedoed by the Turkish destroyer "Muavenet-i-Milliyé" on May 13; on the other hand British submarines were performing invaluable service, diving under the mine-fields, causing havoc amongst enemy craft in the channel itself and higher up, and threatening Ottoman communications with the peninsula.

That the position of affairs had become one virtually of stalemate was fairly evident to all authorities on the side of the Entente before the end of May. A Russian army destined for the Bosphorus, which had been gathered near Odessa, obliging the Porte to keep strong bodies of troops about Constantinople, had been called to Galicia, thus liberating several Turkish divisions for service at the Dardanelles. Only by dispatching very substantial reinforcements in men, munitions and war material to the scene could the Entente achieve its object. But the military situation elsewhere forbade the allocation of strong British or French contingents to this secondary theatre of war, and there was much delay in London in forming a decision. The 52nd Division was, however, under orders to proceed from England to the Aegean; it arrived at Helles early in June, where there was some severe fighting during that month by which the Allies somewhat improved their position.

But trench warfare was the order of the day, and the British and French were trying to carry this on without that ample artillery support which is almost indispensable when earth-works have to be stormed under modern tactical conditions.

others (UB<sub>3</sub>, UB<sub>7</sub>, UB<sub>8</sub>) sailed for the Straits in the latter part of April. UB<sub>3</sub> was lost *en route* but nos. 7 and 8 reached the Straits about the middle of May. They proceeded to Constantinople, and were chiefly employed against the Russian Black Sea fleet. Four small boats of the mine-laying class were also dispatched, of which three (UC<sub>14</sub>, UC<sub>13</sub>, UC<sub>15</sub>) made their way to Constantinople, carrying important technical stores, in the summer months after an intermediate base had been established at Orak near Budrun. Another small boat (UB<sub>14</sub>) on its way from Orak to the Straits, torpedoed the British transports "Royal Edward" off Cos (Aug. 14), and "Southland" in the Aegean (Sept. 2). Other British transports sunk in the Aegean were the "Ramazan" (Sept. 19) and the "Marquette" (Oct. 26). Of the ships named only the "Southland" was brought into harbour.

More important work was done by the seagoing boat U<sub>21</sub>, Lt.-Com. Otto Hersing. This left the Ems after special preparation for the long voyage, on April 25, and reached Cattaro with only half a ton of fuel left on May 13. After replenishing at that base, Hersing sailed on the 20th for the Dardanelles, where, on the 25th and 27th he sank the battleships "Triumph" and "Majestic." U<sub>21</sub> then proceeded to Constantinople. On July 4 he came out and sank the French transport "Carthage" off Helles; later after a cruise in the Aegean he tried to reënter the Straits, but finding the British mine defences too formidable, he sailed to Cattaro to take part in the general commerce-destroying warfare in the Mediterranean. This was by now active, four other seagoing boats having followed U<sub>21</sub> from the North Sea, and it is claimed that 50,000 tons of shipping were sunk in the Mediterranean and Aegean during Sept. 1915. At the end of that month the Germans had nearly one-third of their total available submarine force in this theatre—14 boats out of 44—of which 5 seagoing, 2 small and 1 mine-laying boats, were working in the open, and 3 small (UB<sub>7</sub>, 8, 14) and 2 mine-laying (UC<sub>13</sub>, 15) at Constantinople. In addition, the Austrian boats numbered about 11, large and small, and one of these torpedoed the French cruiser "Leon Gambetta" in Ionian waters on April 27.

Submarine activity in the open Mediterranean and Aegean had no small influence in determining the final abandonment of the Gallipoli enterprise and in preventing its resumption in the later stages of the war. But locally and tactically, no real success was obtained by the new arm after the German submarines on the spot were of no assistance to him, and that the British boats, in spite of their frequent raiding of the Sea of Marmora, did not seriously interfere with his water movements.

A general attack was delivered on the Ottoman positions on the 5th, by which some little ground was gained along most of the front. Then on the 21st the French, who were on the right next to the Straits, pushed their line forward as the result of a well-planned local offensive, and this achievement was followed up on the 28th by a successful operation on the part of the British on the extreme left, by which the line at that end was advanced to nearly abreast of Krithia. Satisfactory as were the results of these two affairs at the end of the month from the point of view of the Allies, they did not render their situation at the extremity of the peninsula much less discouraging than it had been before. The front occupied by the invaders at the end of June was indeed for all practical purposes to represent the line that was to be held up to the night of Jan. 8 in the following year. The Turks still occupied all the high ground. They continued to enjoy all the topographical advantage in respect to position. Ottoman guns dominated the entire territory which the invaders had succeeded in the course of two months in conquering, as well as "V" and "W" beaches which were the landing-places chiefly used by them. This Turkish artillery was bearing up Helles not merely from the uplands facing the Allies' front line, but also from the Asiatic side of the Dardanelles on the Allies' flank. At Anzac the situation remained stationary during June, although there was some sharp fighting at the end of the month.

Both sides, it should be mentioned, were suffering much from sickness, and continued to suffer all through the summer. The heat was great. Flies swarmed. The dust caused much annoyance whenever there was any wind. The British hospital arrangements were not beyond criticism. The water question caused no great difficulty at Helles, but the very limited local supply found within the contracted area occupied by Birdwood's force gave out almost entirely when the dry season set definitely in, and much of that which was brought by sea or condensed had to be conveyed up steep inclines to the trenches. As a result of disease, and of casualties in action and from bombardment, the British divisions recruited in the United Kingdom were constantly far short of establishment, no proper provision having been made for keeping them up to strength. The two Australasian and the two French divisions were better off in this respect; but the number of divisions under Sir I. Hamilton's orders—eight now that the 52nd had arrived—in reality gave a very misleading impression of the strength of the force; his Majesty's Government had, however, during the course of the month decided to dispatch large reinforcements to this theatre of war, and the Allied commander-in-chief had been cheered by the tidings that five further divisions, the 10th, 11th, 13th, 53rd and 54th, had been placed under orders for the Aegean, and would join him between July 10 and Aug. 10. The number of Turkish divisions within the peninsula and in reserve on the Asiatic side of the Straits had, however, grown, and by the end of June Liman von Sanders appears to have had nine under his orders.

July, in so far as the Allies were concerned, was in the main a month of preparation. In view of the anticipated arrival of substantial reinforcements from England there was no great temptation to embark on offensives; and owing to the shortage of artillery ammunition, what there was of it had to be jealously husbanded, although the French divisions were not suffering from this disability so much as the British. A general attack was, however, delivered by the Helles force on the 12th and 13th along the right half of its front, and some little ground was conquered; but the situation was not appreciably modified. Towards the end of the month the 13th Division, the first of the new divisions to arrive, disembarked in this southern area as a temporary measure, bringing welcome relief for the troops in the trenches. At Anzac July passed off quietly. There the rival forces were in close contact, the Turks everywhere enjoying the advantage of command; some sections of the Australasian line were, indeed, completely overlooked by ground in Ottoman occupation. Liman von Sanders was joined by reinforcements from other parts of the Empire early in the month, and the number of Turkish divisions in the peninsula swelled; but, aware that additional British troops were arriving, he felt obliged to



leave forces on the Asiatic side of the Dardanelles in case of a hostile landing on the coast to the S., and of the divisions on the peninsula he kept two about Gallipoli and Bulair.

How best to utilize the fresh troops joining him from England was anxiously considered by Sir I. Hamilton, and he framed his plans well in advance. The French had from the outset favoured operations on the further side of the Straits, and the expediency suggested itself of either throwing the whole Allied army in that direction, or else of diverting the reinforcements thither as a detached contingent. But there were valid objections to either course. A descent S. of the Straits connoted disembarkation in face of opposition, and, even supposing the landing to be successful, the force would start work much further from the Narrows than were either Helles or Anzac. Then again, to plant down a portion of the Allied troops on one side of the Straits, while continuing operations on the other side, would mean voluntary dispersion of resources in place of concentration. The commander-in-chief weighed the pros and cons and he decided against a combination of war on such lines. There were also not wanting inducements for the Allies to attempt a landing near Bulair, seeing that a victory at that point would carry with it the severance of the Turkish land communications with the peninsula. But, here again a disembarkation in face of opposition would have to be risked and a dispersion of resources would arise, while there were strong objections from the point of view of ship transport to conveying troops to a point so distant from the island of Imbros as Bulair; for Imbros was to be utilized as the principal concentration point for the reinforcements from England. That the Ottoman commander-in-chief had to be prepared for his opponent adopting one of these two plans offered a strong argument against adopting either of them.

Hamilton decided that his great effort should be made at, and immediately to the N. of, Anzac. The rugged bluffs on which Gen. Birdwood's force had taken root since April were spurs of a tangled mountain mass known as Sari Bair, from the topmost ridges of which the Straits about the Narrows were partially visible at a distance of 4 or 5 miles. The occupation of these topmost ridges must greatly assist in a further advance across the peninsula here at its narrowest point. The plan decided upon was secretly to augment the force already at Anzac by about a division and a half, and, with the force thus augmented, to secure possession of Sari Bair by a night-attack. But this was only part of the plan. It was also decided that a force of nearly two divisions should, on the same night as the attack on Sari Bair was launched, effect a landing at an entirely new point—Suvla Bay, a few miles N. of Anzac, where the Turkish troops were known to be few. The object of this second operation was twofold—it would indirectly assist the offensive against Sari Bair, it would also furnish the Allies who were planted down on the outer coast of the peninsula with a much more sheltered landing place and base than Anzac Cove. The 13th Division, with some other detachments from Helles and with one brigade of the 10th Division, were the troops chosen to augment Birdwood's force already at Anzac. The new venture further north was entrusted to the 11th Division, which was to assemble in the island of Imbros supported by the rest of the 10th Division; the portions of this latter division not detailed for Anzac were to concentrate partly at Mudros, and partly in a port of Mytilene more than 100 m. from Suvla. The last divisions to arrive, the 53rd and 54th, were to be employed wherever should seem best after the offensive had begun. To land the whole of the reinforcements simultaneously would not have been practicable with the amount of water transport available.

The utmost secrecy was observed by the Allied staff. Appropriate steps were taken to mislead the Ottoman authorities by means of feints and of reconnaissances executed at localities other than those selected for operations. False reports were assiduously circulated by the intelligence department. This part of Hamilton's programme was, indeed, carried out most successfully, for, although Liman von Sanders was aware of the arrival of large bodies of British troops in the islands, he remained entirely ignorant of his rival's real design until this was actu-

ally in execution. The Ottoman commander had organized his forces as a southern group watching Helles and a northern group watching Anzac, with the already mentioned two divisions at the Bulair end of the peninsula. There were large Turkish forces in reserve about Chanak, in addition to substantial contingents disposed to the S. of the outlet of the Straits ready for any move of the Allies in that quarter; but, thanks to a system of jetties erected on either shore at the upper end of the Narrows, and to improved communications, troops could be shifted from side to side of the waterway very rapidly. Numerically, the contending armies would at this very critical juncture of the campaign be almost equal, the invaders rather the stronger; but the Turks were much dispersed, so that the result almost hinged upon the speed with which the attacking side should gain ground before the defenders had time to concentrate.

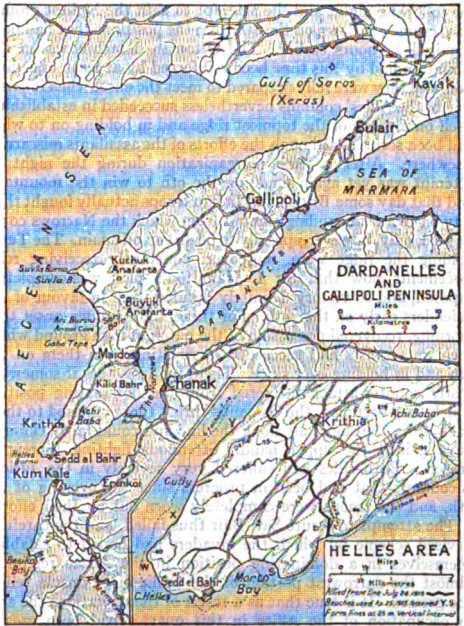

The offensive started on Aug. 6 with two preliminary enterprises. An onset was made upon some of the Turkish trenches in the Helles area, which led to sharp fighting; the object was to prevent the Turks transferring troops northwards, and it probably served its purpose; apart from that, little was accomplished although the affray went on intermittently for a week. Portions of the Australasian force also broke out of the southern sections of the Anzac position, and were rewarded by the acquisition of some very valuable ground after a violent contest; the real purpose, however, was to occupy the attention of the enemy and to conceal a design of much greater moment.

So dexterously had the assembling of the reinforcements within Birdwood's position been effected, that the Turks had entirely failed to detect how the numbers of their opponents in this area had during the last few nights been nearly doubled. The scheme of operations for the capture of the Sari Bair mountain mass was that the force detailed for this enterprise should move out in several columns from the northern end of the Anzac position along the low ground near the shore, after dark on the evening of the 6th. On reaching their appointed stations the columns were to wheel to the right and were to work their way up certain steep but well-defined gullies that led towards the



topmost ridges, which, it was hoped, would be reached by daylight—a somewhat sanguine anticipation, as it turned out. All went well at the outset. The Turkish posts about the lower spurs were in some cases surprised. The outlets of the gullies were in the assailants' hands soon after midnight. The hostile detachments on guard gave way at all points. But the routes to be followed were difficult to find in the dark, the ascent was rapid, the ground was much broken, and the enemy opposed a stubborn resistance to the advance, with the result that this was greatly retarded, and that at daybreak the most forward of the columns was not much more than halfway up. The Ottoman staff had, moreover, on the first alarm begun to hurry reinforcements on the Sari Bair from the rear, while the Allied troops were so much exhausted by their nocturnal experiences that all attempts to win the upper ridge failed on the 7th.

A rearrangement of the attacking forces was carried out during the following night, and the attempt to gain the highest ground was resumed at dawn on the 8th from the positions that had been acquired 24 hours earlier. The Ottoman detachments on the mountain had by this time been reinforced by at least one division, and they were fully prepared to meet the onset when it came. One of the Allies' columns nevertheless succeeded in establishing itself on a patch of the topmost ridge and in holding on to what had been secured, although the efforts of the assailants miscarried elsewhere. After a fresh reorganization during the night an attempt was yet again made on the 9th to win the mountain, and that day some British and Indian troops actually fought their way on to a commanding summit from which the Narrows could be seen, only, however, speedily to be driven off again. The Turks holding the ridge were, moreover, constantly receiving reinforcements now that Sir I. Hamilton's plan was completely exposed, and so victory definitely decided itself in favour of the defenders early on the 10th. For these, by a sudden onset that morning, recovered possession of the patch of high ground which their antagonists had succeeded in wresting from them on the 8th and in holding ever since. Then, by a resolute if somewhat costly counter-attack delivered from the dominating position which they occupied, the Osmanlis thrust those opposed to them back down the slopes all along the line and could fairly claim to have gained the upper hand. Struonous fighting thereupon ceased. Both sides had suffered very severely in the furious encounters that had been in progress since the evening of the 6th, and the troops were completely worn out by their efforts.

The attempt to secure Sari Bair thus failed, and the carefully devised scheme by which the invaders had hoped to establish themselves in a dominating position in the Anzac region at almost the narrowest portion of the Gallipoli Peninsula fell to the ground. It is true that as a result of the operations the area in occupation of the Allies in this quarter had been greatly extended in a northerly direction, so much so indeed that little difficulty was experienced by Gen. Birdwood in securing close contact with the contingents that had landed at Suvla on the night of the 6th-7th, and from which substantial support had been expected. As a matter of fact, the Suvla troops had afforded the Anzac columns no assistance at all beyond occupying the attention of one of the two Turkish divisions which Liman von Sanders set in motion south-westwards from about Gallipoli as soon as he had satisfied himself as to where danger lay, and the doings of this newly landed force had now to be recorded.

The plans for bringing the 11th Division and bulk of the 10th Division from the islands to Suvla and disembarking them had been elaborated with meticulous care by the naval and military staffs. As Turkish detachments watching this strip of coastline were known to number only about 2,000 men—the Ottoman authorities never contemplating a hostile landing in force in the locality—the design was to put most of the attacking troops ashore during the night of the 6th-7th as a surprise, and that they should then push on at once and master a range of hills 4 or 5 m. to the east. At Suvla Point the coast (which from there down to about Holles runs roughly N. and S.) turns abruptly to the N.E. to form one side of the Gulf of Saros; along this stretch of the shore a well-defined ridge, starting close to the headland, rises

almost like a wall from the sea and overlooks what may be called the Suvla area from the N., just as the above-mentioned range of hills overlook the area from the east. The area is mostly flat up to the foothills. Close to the bay there is a lake—a marsh in dry weather—which necessarily cramped the movements of troops landed at or near the bay. Army headquarters assumed that the plain, with the high ground to the E. and N., would be in British hands early on the 7th.

The 11th Division from Imbros was to disembark first, and was to be on the right in the subsequent advance. The 10th Division from Mudros and Mitylene was to follow it ashore, and moving forward on the left, would secure the northerly ridge. Most of the 11th Division was to land just S. of the bay, but one brigade was to gain its footing inside the bay. The work was to begin as early as possible, allowing for the flotilla only quitting Imbros after dark. Especially constructed lighters, with ~~more~~ power, were to play an important part in the disembarkation, a number of them having recently arrived from England. Elaborate arrangements had been made for water supply to the troops ashore, as the whereabouts and the capacity of wells were doubtful. The secret had been well kept, and a difficult operation of war was in its opening stages most successfully carried out.

The two divisions detailed for this Suvla enterprise both belonged to the British "New Army"; they were unconcerned with active service conditions, having come straight out from England, and they were being highly tried in being called upon to execute a landing in force at night in face of opposition. There was, indeed, no precedent for an undertaking of this kind under modern tactical conditions. Nevertheless the whole of the infantry of the 11th Division was on shore before dawn, and its leading battalions had driven off the Turkish detachments met with in the immediate vicinity of the points of disembarkation. The only hitch that had occurred during the night-time had been at the landing-place within the bay, where the water had proved to be inconveniently shallow for the lighters; this had caused some confusion and delay. But the urgent need of pressing forward at once was not realized by the attacking side, and its opposition offered by the parties of Osmanlis close to the bay was taken too seriously after daylight. Moreover, when the first portion of the 10th Division arrived from Mitylene soon after dawn, it was decided to put these troops ashore to the S. of the bay, instead of inside the bay as had been intended; so that they found themselves, to start with, on the right of the 11th Division and not on its left, the general line of contemplated advance being to the N. of the lake. They were unfortunately moved from right to left, and this took many hours.

During the forenoon a good landing-place was found inside the bay on its northern side, and the contingent of the 10th Division from Mudros disembarked at this point. But no veritable advance in force took place until comparatively late in the afternoon, and by evening the attacking side, although enjoying a great numerical superiority, had only reached the foot of the hills that lay to the E. of the landing-places and captured one advanced spur. The troops had during the latter part of the day suffered greatly from thirst, the arrangements with regard to water having practically broken down mainly owing to the inexperience of the troops themselves.

When Liman von Sanders (who had fixed his headquarters near Gallipoli) learned during the night of the 6th-7th that the Allies were landing in strong force about Suvla, and were also attacking Sari Bair from Anzac, and after he had satisfied himself that certain threats on the part of his opponents at other points might be regarded as mere feints, he ordered the two Turkish divisions under his immediate orders to proceed towards Suvla with all speed. This, however, meant a two days' march along indifferent roads. The only Ottoman detachments which during the 7th and 8th confronted the two British divisions that had made a descent on this locality were those which had been on guard on the spot when the landing was taking place. Consequently there was still on the 8th a great opening left for the attacking side to complete the first part of its programme, i.e. to

gain possession of the heights to the E. of Suvla; which dominated the landing-places and the whole of the area in their immediate vicinity that had been occupied on the 7th. The very few Ottoman guns which had been causing the freshly disembarked troops a good deal of annoyance during the 7th had been withdrawn for fear of capture, the defenders fully expecting a forward move by the Allies. But no move forward took place. The opportunity was allowed to slip by. The Turks remained in possession of the high ground, and that night reinforcements began to join them from the N.E., the troops as they came up being rushed into position in view of impending attack.

That attack was at last delivered early next morning. It failed completely. Enjoying the benefits of occupying a commanding line, the defenders were also being reinforced during the progress of the combat. Although sustained by a fair number of guns and with the moral support of the 53rd Division, which had disembarked during the night, the 10th and 11th Divisions could make no headway. The deliberation of the Allies on the 7th and 8th, when the forces opposed to them were insignificant, had been fatal. The great numerical superiority which they had at first possessed was gone by the 9th, and their task had come to be the ejection of an almost equal enemy from a naturally formidable position. That day was also the last on which any hope remained of the Sari Bair offensive accomplishing its purpose, and on which help from Suvla might conceivably even at the eleventh hour have turned the scale. The defeat suffered by the Suvla troops on the 9th was in reality decisive in so far as the new area was concerned; but, even so, the invaders who had set foot there tried yet again on the 10th to wrest the heights in front of them out of Osmanli keeping. The effort, however, failed, and further offensives in this quarter were abandoned for the moment.

The situation on the 11th offered little encouragement to the invaders. The carefully devised scheme of operations from which they had expected so much had come to naught in its most important features. A footing had no doubt been gained at Suvla, giving the Allies control of a fairly well-sheltered inlet on the outer coast of the peninsula, but as the high ground within easy artillery range of the landing-places, and which overlooked the whole occupied area, remained in the hands of the Turks, much of the benefit hoped for from the acquisition was in reality neutralized. As had been the case at Helles and at Anzac ever since the first opening of land operations in April, only a restricted patch of Ottoman territory had been obtained by the new undertaking, and although the position at Anzac had been extended and improved it remained an extremely bad one. The Allies now occupied many miles of front in the peninsula, but there was hardly a spot where the enemy had not the upper hand in respect to ground—what they required was not breadth but depth, and depth they had failed to secure. They had moreover incurred very heavy losses in the combats of, and since, Aug. 6. There were yawning gaps in their ranks. Except a division from Egypt; coming to fight on foot, no reinforcements were on the way, and the last of the five divisions from England, the 54th, had been swallowed up at Suvla. The defending side had also, no doubt, suffered heavily in casualties, especially on Sari Bair; but the Turkish commander-in-chief could fairly claim that, if some ground had been lost, he had held his own in a contest in which his adversary had enjoyed some notable advantages at the start.

An effort was made on the 12th by the troops on the extreme left of the Allies' position at Suvla to gain ground along the ridge N. of the plain; but nothing came of it. Sir I. Hamilton, however, still entertained hopes of effecting some improvement in his position in this area. The mounted division, and also a division from Helles, were quietly concentrated there, and on the 21st a determined attempt was made to capture some of the high ground which had baffled the essays of the invaders on the 9th and 10th. Large forces were engaged on either side in this battle, and the attack was prepared for by a comparatively speaking heavy bombardment of the Ottoman trenches; in this battleship and cruisers moored in Suvla Bay, in security from submarines, participated. But after a sanguinary contest the assailants met with repulse, and from that date onwards no serious offensive

operation was attempted by the Allies in the Dardanelles campaign. Those conditions of virtual stalemate which had prevailed before the arrival of the five new divisions from England set in afresh, and they continued to the end.

Even before this final reverse, Sir I. Hamilton had cabled home asking for reinforcements and for very large drafts that were needed to bring the depleted units under his command up to their war establishment. The total figure he asked for amounted to 95,000 men, his calculation being based upon the strength of the opposing army, as this was fairly accurately known. He had, however, been informed that no large bodies of fresh troops could be spared for the Dardanelles theatre of war. A temporary change of plan did occur a few days later, owing to the French Government proposing to despatch four divisions to the Aegean with the idea of their operating on the Asiatic side of the Straits; under the circumstances the British Government was also prepared to send fresh divisions to Sir I. Hamilton. But early in Sept. these projects were finally dropped both in Paris and in London, owing very largely to the threatening aspect of affairs that was arising in the Balkans.

The campaign by which the Central Powers and Bulgaria crushed Serbia for the time being, and by their triumph opened communications through Bulgaria with the Ottoman Empire, profoundly influenced the situation in the Gallipoli Peninsula. Not only was all idea of reinforcing the Allied army that was planted down in this region abandoned by the western Governments; but even some of the troops under Sir I. Hamilton's orders were transferred to Salonika. Moreover, the linking up of Turkey with the Central Powers by railway ensured that Limas von Sanders would in due course be furnished with ample munitions of all kinds, and this must make the prospect of Entente forces gaining possession of the Straits rather than even.

As early as the middle of Sept. the French Government had come to the conclusion that there was now no hope of victory in the Dardanelles theatre of war. The British Government, on the other hand, influenced to a great extent by anxiety as regards prestige in the East, could not arrive at a decision as to giving up the project. After two or three weeks Sir I. Hamilton was, however, invited to give his views concerning the question of evacuating the peninsula and abandoning the enterprise against the Straits. On the commander-in-chief pronouncing himself as emphatically opposed to such a step, Sir C. Monro was sent out from England to take his place. Impressed by the unsatisfactory positions in which the Allied troops found themselves on the peninsula, by the impossibility of their making any progress at their existing strength, and by the risks that the army ran in remaining on such shores without any safe harbour to depend upon for base in stormy weather, Monro, after examining the situation on the spot in the closing days of Oct., declared unhesitatingly for a complete withdrawal. The British Cabinet thereupon despatched Lord Kitchener to the Aegean to investigate and to report. He had viewed proposals to abandon the campaign with alarm; but after visiting the peninsula he realized that evacuation was the only justifiable course, and he reported to that effect. All this time winter was drawing nearer and nearer and the need for a prompt decision was becoming more urgent, but the authorities in London lost another fortnight before, on Dec. 8, they at last sent instructions to Monro to evacuate Suvla and Anzac while retaining a grip on Helles.

Sept., Oct. and Nov. had been months of stagnation for the armies that confronted each other on the peninsula, as was, indeed, almost inevitable under the strategical conditions which had come about. The Ottoman higher command was well content that the troops under its charge should maintain an attitude of passive defence; they were keeping Allied divisions in idleness which, were they to be transferred to some other one of the theatres of war, might prove invaluable assets to the cause of the Entente. Well concealed in skillfully constructed entrenchments that were excavated on terrain overlooking the invader's lines, the Turkish contingents holding the different fronts could fairly calculate upon beating off any hostile attack unless their adversaries should be heavily reinforced. The defenders could in

fact afford to remain quiescent. The Allies, on the other hand, were practically compelled to remain quiescent. The general situation offered them no inducements to embark on fresh offensives. The great Aug. effort, which had been made when they were enjoying the advantages derived from concentration as opposed to dispersion, and when they were in the position to take the Turks unawares, had miscarried. It would have been folly after that experience to risk defeat and perhaps disaster in assailing formidable positions, effectively held and assiduously fortified. The Allies had in Aug. been rather superior in numbers to their opponents. But during the autumn Liman von Sanders was reinforced by several divisions, and at the juncture when Gen. Monro arrived and recommended evacuation of the peninsula, the Ottoman host gathered about the Dardanelles was already decidedly stronger in point of numbers than was the army which was clinging to patches of littoral without a sheltered base.

If there had been no fighting during these autumn months worthy of mention, much creditable work had been carried out by the invaders in respect to developing communications and to improving jetties and landing-places, especially at Suvla. One British and one French division were moved from the peninsula to Salonika early in Oct., but an additional Australian division had arrived a few weeks earlier. In spite of the discouraging conditions in which they found themselves, and of the constant annoyance suffered from hostile artillery fire, the troops were in fair heart, while the tactical efficiency of the recently created divisions, which had not been of a high standard when they arrived in the theatre of war, had appreciably progressed. The proportion of sick had been high during the summer-time, but it decreased somewhat after Sept. On the other hand a very severe blizzard, lasting two days, swept the whole region towards the end of Nov. and caused havoc amongst the divisions in the Suvla area, which was particularly exposed to the elements, this visitation augmented the numbers in hospital by several thousands. The tempestuous weather, moreover, created serious damage at most of the landing-places, where solidly constructed jetties were in some instances completely demolished by the seas. The Allied forces had been organized as three distinct groups. That at Helles (which included the French contingent, still as at the outset on the right) was under the charge of Gen. Davies. That at Anzac, composed mainly of troops from the Antipodes, remained under Gen. Birdwood. That at Suvla was commanded by Gen. Byng. But as Gen. Monro found himself responsible for the British troops at Salonika as well as for the Allied army of the Dardanelles, he placed the latter under charge of Gen. Birdwood, while Gen. Godley relieved Birdwood at Anzac.

Like their adversaries, the Turks had suffered much from disease during the summer. But as their numbers grew in the autumn, and as their headquarters staff noted how the invaders were dwindling away owing to transfers to Salonika and to no drafts arriving to replenish wastage, it became possible to keep a number of the Ottoman divisions in reserve, well in rear of the fighting fronts or else on the Asiatic side of the Dardanelles. This also permitted of the troops in the trenches being relieved and rested at frequent intervals. The defending side, in fact, came to be in a much more favourable position than was the attacking side in respect to diminishing the strain that is always experienced by fighting personnel when in close contact with an enemy even during periods of virtual inactivity. The Sultan's forces guarding the Straits were not yet at the end of Nov. deriving much benefit from the strategical transformation which had taken place in the Balkans consequent upon communications being opened between Thrace and the Central Powers; but there was every prospect of heavy artillery and munitions shortly beginning to find their way through from Germany and Austria-Hungary to the Dardanelles.

Foreseeing that the British Government must ultimately resign itself to a withdrawal of the Dardanelles army from its dangerous situation on the Gallipoli Peninsula, Monro had already, some days before the permission to evacuate reached him from home, given instructions that certain preparations were to be made towards facilitating that operation. That a retirement

of this kind was a hazardous undertaking was realized from the outset. There was no precedent for large military forces, in close contact with a formidable enemy, embarking within easy artillery range of positions in the hands of the opposing side, and the most sanguine amongst high military authorities in the councils of the Entente feared that a withdrawal could not be carried out without incurring heavy losses. The responsible authorities on the spot perceived that the process of gradually removing the huge accumulations of impedimenta that were massed about the landing-places and of reëmbarking the troops must take place during the dark hours and step by step, every effort being made to keep the Turks unaware of what was in progress. Sickly men and some stores and animals had been got away before Dec. 8, which lightened the task in prospect. The tactical principle on which withdrawal would be carried out when the time came had been fully considered. The naval authorities had been busy assembling and organizing the available small craft in anticipation of the operation that appeared to be imminent, and jetties damaged in the Nov. gales were being repaired. It should be noted that the matter in hand was, from the point of view of water transport, somewhat facilitated by the British Government's determination to hold on to Helles for the present, as nearly all the lighters, boats, etc., in naval charge could consequently be gathered at Anzac and Suvla.

Birdwood decided, in consultation with Godley and Byng, that the front trenches should be held up to the very last moment at the night of final evacuation, the troops manning them then hastening to the beaches, everything removable, whether animate or inanimate, having already left. There was to be no taking up of successive positions in accordance with the normal practice of rearguard actions. At a given moment the trenches, which at many points were but a few yards from those occupied by the Turks, would be vacated by detachments, which by that hour would have shrunk to mere handfuls of men. Scarcely a shot had since the beginning of Dec. been fired after dark by the British, Australasian and Indian troops, who were holding the long line stretching from the Gulf of Saros to near Gaba Tepe, so as to accustom the foe to quietude during the night watches. The last parties of the Anzac force were to ship at Anzac Cove but for a detachment on the extreme left, which would embark with the Suvla troops. The Suvla area was divided into two sections, the troops in the right (or southern) section retiring S. of the lake and taking to the boats on the southern side of the bay, the other section retiring N. of the lake and embarking on its northern side. The final night was provisionally fixed as that of the 18th-19th, and thanks to favourable weather and to the efficiency of the arrangements, the very critical operation was carried out with triumphant success, just as had been laid down by programme ten days before.

Night after night during the intervening ten days the landing places at Anzac and Suvla were scenes of unceasing activity. Masses of war material and food supplies were in the first instance removed; then most of the animals were got away, lastly portions of the troops began to embark and to proceed to Imbros or Mudros. During the daytime reliefs took place as usual, preferences were made of disembarking animals and stores at the jetties, and the result was that the Turks remained in complete ignorance as to what was going on close to their lines. Large bodies of infantry with a fair proportion of guns still remained on shore on the 17th, but of these roughly half—about 10,000 men and a number of guns in each area—were removed that night, so that on the 18th only a meagre force, composed almost wholly of infantry and disposed almost entirely in the trenches, was holding a long front face to face with a numerically far stronger enemy. But, fortunately for the Allies, their dispositions had been so skilful that the Ottoman staff had not ascertained that the Anzac and Suvla areas had been almost vacated. The critical day passed without incident.

The hour fixed for finally quitting the front trenches in the Suvla area, and the adjacent northern portions of the Anzac area, was 1:15 A.M. on the 19th. Owing to their vicinity to the cove the east of the Anzac trenches were, however, to be held till 1

later hour. At nightfall the very few guns still to go were hurried off to the jetties. Then the troops along the front were quietly withdrawn in successive groups, the fine weather continuing to the end and work at the beaches proceeding without a hitch. Finally the parties still in the trenches slipped away, and when dawn broke the Turks, who had first ascertained that something unusual was afoot from the explosion of a vast mine in the Anzac area, and from conflagrations on the beaches where the few stores to be abandoned were being destroyed, discovered that the invaders were gone. Twenty-four hours later the long spell of calm, a godsend to Godley and Byng, came to an end.

Practically nothing worth mentioning had been left behind at Suvla. At Anzac, where conditions favoured the retreating troops less, it had been necessary to destroy some valuable war material at the last moment, and a few worn-out guns had purposely been abandoned. The casualties in the two areas on the final night had amounted to two. The relaxing by the Allies of their frail hold upon the outer coastline of the Gallipoli Peninsula had been effected more successfully than the most sanguine amongst them had permitted themselves to hope for. Yet, for a week subsequent to their receiving the glad tidings from the Aegean, the British Government remained irresolute with regard to the policy to be pursued at Helles. Then, on Dec. 28, Monro received the expected sanction for evacuating that area also, and Birdwood promptly grappled with this fresh problem.

Taken unawares and signally out-manœuvred at Anzac and Suvla, Liman von Sanders perceived that his antagonists would probably retire from Helles also, and he took measures accordingly. He had at this time 21 divisions at his disposal, while there were only four British divisions to oppose them at Helles (the last French division left for Salonika during Dec.). The Turks, therefore, now possessed a huge numerical preponderance in the theatre of war. They moreover enjoyed an even more marked superiority in respect to artillery, and this the Ottoman commander-in-chief hastened to turn to account; the heavier guns which had been sweeping the Anzac and Suvla areas for months past were promptly transferred to the high ground overlooking the extremity of the peninsula or to positions on the Asiatic side of the Straits from which the extremity of the peninsula could be effectively taken in flank.

The same principles as those which had been so successfully applied during the evacuation of the northern areas, were put in force at Helles. The work of removing stores, war material, animals and personnel was to be carried out on successive nights, the fighting force ashore was to be gradually reduced, the front line of trenches was to be held up till the very last—the final night being fixed provisionally for the 8th–9th—and the detachments vacating it were to hurry straight off to the beaches. So as to deceive the enemy, bombing and rifle fire were to be practised nightly up till 11:30 P.M., after which all activity was to cease. Two possible eventualities had especially to be feared—the sea might get up, or a heavy bombardment of the beaches might be instituted by the Turks while the final evacuation was in progress. As the staff fully foresaw, the enemy would exert greater vigilance than had been the case while the withdrawals had been in progress from the northern areas, these having given the Ottoman authorities warning of what was likely to happen. It ought also to be mentioned that there was a greater accumulation of impediments at Helles than there had been at either Anzac or Suvla, so that even if the weather were to remain favourable, it was certain that material of great value would have to be destroyed to prevent its falling into the enemy's hands.

Embarkation operations were carried on almost entirely at "V" and "W" beaches, at both of which there were provisional breakwaters in existence furnishing some shelter when there was an onshore breeze. The weather, as it turned out, was none too favourable on several of the preliminary nights, but, owing to its direction, the wind did not greatly retard the work of removal. The enemy's guns gave a good deal of trouble at the beaches, and caused many casualties. Although steps were taken to conceal what was in progress, the Turkish staff were aware that preparations for evacuation were in full vigour; but they could

not foresee the date on which the final fitting would take place, nor could they make sure how far the number of combatants within the British lines had been reduced. With the object apparently of ascertaining the strength of their opponents, the Ottoman forces on the afternoon of Jan. 7 delivered a half-hearted attack upon the left of the British position, following on a violent bombardment; but the assailants were driven off with little difficulty. Nor would they seem to have discovered how weakly held the trenches were; for a considerable proportion of both infantry and artillery had been withdrawn by that date, as only two more nights remained according to the programme. That night the troops still left at Helles were reduced by one-third, and, on the next day breaking fine, it was decided to complete the operation on the following night as intended at the start.

The right half of the British were to withdraw by "V" beach and the left half by "W" beach, except that the final detachments on the extreme left, representing the 13th Division, were to be got off at Gully beach. A large number of guns had been retained ashore in view of the danger of a determined attack by the Turks on the 8th, when the lines were thinly held; it had been decided to abandon several of these, worn-out ordnance being earmarked for the purpose. The artillery still remaining to be embarked was for the most part got aboard during the early hours of darkness, and the infantry followed; but the wind soon began to rise ominously, blowing home from W and S.W., and as the hours passed the situation at the beaches became disquieting. The last detachments to quit the trenches moved off simultaneously all along the front at 11:45 P.M., without the enemy noticing their departure, and they were embarked successfully at "V" and "W" beaches according to schedule in spite of the heavy seas. But the detachments designated for Gully beach could not all be got off at the exposed point, and those left over had to march on to "W" beach at the last moment and were not afloat till nearly 4 A.M., their embarkation being effected with great difficulty owing to the surf. Just before the last boats sheered off the masses of stores which it had been necessary to abandon were set on fire, and only from the glare set up by this conflagration were the Turks made aware that their opponents had evaded them yet again.

Although the evacuation of Helles without appreciable loss in personnel reflected great credit on the British staff and the troops concerned in it, as also on the Royal Navy, whose work at the beaches was carried out under great difficulties, the escape of the final remnants of the Dardanelles army from the Gallipoli Peninsula was facilitated by the negligence of the troops opposed to them. Had the Turks kept befitting guard on the night of the 8th–9th, aware as they were that their antagonists contemplated departure, they must have detected that the British trenches had been vacated. Effectual pursuit might not have been practicable; but the guns could have been turned on to the beaches, of which the range was exactly known, and embarkation, impeded as it was by the rough water, could hardly have been carried out without many casualties.

After a few days taken up in collecting the troops from Helles in their different divisions at Lemnos, what was left of the Dardanelles army was shipped to Egypt, whither most of the forces from Anzac and Suvla had already proceeded. The total loss of the Allies' military forces in the eight months' contest mounted up to 130,000 killed, wounded and missing.

Most authorities on the art of war agree that the collapse of the Entente in this memorable campaign was primarily due to the abortive naval effort to force the Dardanelles. By embarking on that venture the fleet gave the Turks sufficient warning of what was in store to ensure that, on the date on which Sir I. Hamilton's army was ready to land, the defenders should be in a position to bring it to a standstill. The only chance of the invaders achieving their object after the first week of land fighting depended on their being joined by very substantial additional forces in a region where a belligerent fighting on the defensive in home territory, as the Osmanlis were, enjoyed marked strategic and tactical advantages. But neither the British nor the French could afford to divert great military resources from the main theatre

of war in western Europe to the Aegean, and so the struggle for the Straits ended in mortifying discomfiture for the Allies.

(C. E. C.)

**DARLING, SIR CHARLES JOHN** (1849— ), English judge, was born at Colchester Dec. 6 1849. He was educated privately, and in 1874 was called to the bar. He became a Q.C. in 1885, in 1888 successfully contested Deptford in the Conservative interest, and in 1892 became a bencher of the Inner Temple. He was raised to the bench and knighted in 1897. He has published some volumes of light verse, including *Scintillae Juris* (1877). In 1917 he was made a Privy Councillor.

**DARTMOUTH COLLEGE**, Hanover, N.H., U.S.A. (see 7.838), in the period between 1908 and 1921 experienced a great expansion in its plant, endowment and enrolment. Its educational plant in the latter year included 21 buildings devoted to lecture and recitation rooms, laboratories, and administration and similar purposes.

Of these, the extensive alumni gymnasium was erected in 1910, to which was added the Spaulding swimming pool in 1920; the Parkhurst administration building was erected in 1910; Robinson Hall, the home of all undergraduate organizations except athletic, in 1914; and a large chemical laboratory in 1920-1. The plant also included 18 dormitories, of which five were added after 1908, the latest in 1920, capable in all of housing 1,100 students. The value of the plant was over \$2,000,000.

In addition to the educational plant the college had 20 single or apartment houses for the use of its faculty. Its productive investment assets nearly doubled in the 12-year period, approximating \$5,500,000. In 1920-1 it had 150 officers of administration and instruction, and there were 1,875 enrolled students, of whom 54 were in post-graduate courses. The tuition fee was \$250 a year. The constituency of the college, formerly mainly in New England, extended to the whole country. In 1910 62% of the freshmen came from New England. One of the chief influences leading to expansion was the Outing Club, the first college club of its kind, which was open to both faculty and students and had as its object the stimulation of healthful outdoor activities. It owned a chain of seven cabins, extending over 75 m. from Hanover to the White mountains and equipped for the accommodation of its members on their excursions into the country and among the mountains. Its winter activities culminated in a carnival of sports.

Like other American colleges, Dartmouth was greatly affected by the World War. Even before the Alliance of the United States, many of its students had joined the Allied armies or served in the ambulance corps in France, and in Feb. 1916 a battalion of 218 men in two companies was formed for military drill. In March 1917, the great majority of the students was enrolled for military training, and in the following fall military training was required of the freshmen. After the United States entered the war, the college became practically a camp, for all able-bodied students between 18 and 21 years of age were inducted into the Students' Army Training Corps and trained under military regulations, and those under 18 were enrolled in the corps, although remaining under college authority. There were also vocational sections of about 550 men who came to the college from outside for instruction in carpentry, cement work, truck driving and repairing, and radio work. All military training came to an end in Dec. following the Armistice, and the college reverted to its former status. In consequence of the war the enrolment fell from more than 1,500 to 761, of whom only 110 were not under military training. Many members of the faculty engaged in war service in the United States or in France, either under the Government or in the organizations supplementary to the military. The total number of undergraduates (from the six classes 1917 to 1922) who entered the war or served in the S.A.T.C. was 1,817 and of the faculty 73. The total number of Dartmouth men, graduates, undergraduates, and faculty, who served in the army, navy or marine corps was 2,603, in the auxiliary service 752.

(E. M. Ho.)

**DARWIN, SIR GEORGE HOWARD** (1845-1912), English astronomer, was born at Down, Kent, July 9 1845. The second son of Charles Darwin (see 7.840), he was second wrangler and Smith's prizeman at Cambridge, and was elected to the professorship of astronomy and experimental philosophy at his university in 1883. His principal work was on the subject of tides, on which he became the leading authority, and on other physical questions connected with the relation of the earth and moon; the article *Tide* in the *E.B.* (see 26.938 et seq.) represented his matured researches on his special subject. He was made K.C.B. in 1905 and died at Cambridge Dec. 7 1912.

**DATO, EDUARDO** (1856-1921), Spanish politician, was born at Corunna Aug. 12 1856. He graduated in law at the univer-

sity of Madrid and was elected a deputy in 1884. An under-secretary for the Home Department in 1892, he became minister for the department in 1899, and distinguished himself in the study of social legislation, the fruits of which were special bills regarding accidents, insurance, and women's labour. In Dec. 1902 he became Minister of Justice, in 1907 mayor of Madrid, then president of the Chamber. He was elected a member of the Royal Academy of Social and Moral Sciences, June 20 1905. When in 1913 Señor Maura refused to take power except on conditions unacceptable to the King, Señor Dato, thinking that the Conservative party could not refuse to serve the Crown at a difficult moment, dissented from his chief, carrying with him the majority of his party, which elected him as its leader. He was still in office (1913-5) when the World War broke out, and was responsible for Spain's declaration of neutrality. He adhered firmly to that policy. Becoming prime minister again in 1917, he faced the great crisis of that summer. In 1920 he resumed office, and it was while prime minister that he was murdered in Madrid March 8 1921. Señor Dato had great social charm, persuasive talent and an unswerving will under flexible appearances.

**DAUDET, LÉON** (1867— ), French writer, son of Alphonse Daudet (see 7.848), was born in Paris Nov. 16 1867. He was educated at the lycée Louis le Grand, and afterwards studied medicine, a profession which he abandoned in 1894 for that of literature. He wrote many short stories and novels, and has also contributed to the *Figaro*, *Gaulois* and *Libre Parle*. He is an ardent royalist in politics, and was one of the group which in 1908 founded the royalist organ *L'Action Française*. He published in 1898 a Life of his father, and among his other works may be mentioned *Les Morticoles* (1894); *Les Deux Bécasses* (1901); *La Déchéance* (1904); *Les Primaires* (1906); *La Lutte* (1907) and *L'Avant-Guerre* (1913). He produced various essays on the World War, and his latest novels include *Le Vermis du Monde* (1916); *Le Bonheur d'être Riche* (1917); *Le Cœur et l'Absence* (1917) and *Dans la Lumière* (1919).

See R. Guillon, *Léon Daudet* (1918).

**DAUMET, PIERRE JEROME HONORÉ** (1826-1911), French architect, was born in Paris Oct. 23 1826. He entered the École des Beaux-Arts in 1845, and was awarded the Grand Prix de Rome in 1855. In 1861 he was attached to the important exploratory expedition and mission in Macedonia, and was commissioned to draw up the report. In the following year he was appointed inspector of works for the then recently created Prefecture of Police, and was later acting architect to the Palais de Justice, succeeding in 1876 Viollet-le-Duc as architect-in-chief. This fine building may be regarded as one of the great and lasting monuments of his career. During the next few years Daumet's talents and artistic equipment, especially in matters of archaeological interest and research, received recognition from the French Government in his appointment to many official positions, culminating in his vice-presidency of the Commission des Monuments Historiques. His brother-artist distinguished him by electing him vice-president of the Société des Artistes Français, and president of the Société des Architectes Français. In 1885 he was elected a member of the Académie des Beaux-Arts, and in the following year an hon. corresponding member of the Royal Institute of British Architects, who further awarded him their gold medal in 1908. One of the highest expressions of his genius was his restoration of Chantilly in close collaboration with the Duc d'Aumale, who later (in 1897) bequeathed it to the French nation, as represented by the Institut de France. Among Daumet's many architectural works may be noted the following:— The Palais des Facultés and the Palais de Justice at Grenoble, the Ecce Homo chapel at Jerusalem, the pension and chapel of the Dames de Sion in Paris and Tunis, his early work at the Asile des Aliénés of Ste. Anne, and the Palais de Justice, Paris, already mentioned. His literary work, besides his important account of the archaeological mission to Macedonia, includes a book on the Château de St. Germain and its restoration for which he was responsible. His

services to the educational side of his art were considerable. His *atelier* produced no less than nine holders of the Grand Prix de Rome—a notable record. He died Dec. 13 1911.

**DAVIDS, THOMAS WILLIAM REYS** (1843— ), British orientalist, was born at Colchester May 12 1843. Educated at a school in Brighton and at Breslau University he entered the Ceylon civil service in 1866 and also read for the bar, becoming a barrister of the Middle Temple in 1877. He became a close student of Buddhism and of the literatures of India, and in 1882 was appointed professor of Pali and Buddhist literature at University College, London. In 1904 he became professor of comparative religion at the university of Manchester. Amongst his numerous publications are *Buddhism* (1878, 18th ed. 1899); *Ancient Coins and Measures of Ceylon* (1877); *Buddhist India* (1902); *Early Buddhism* (1908); and the articles on *Buddha*, *Buddhism*, *Pali*, *Lamaism*, etc. in the *E. B.* He became president of the Pali Text Society, which he founded in 1882, and a fellow of the British Academy. He married in 1864 Caroline Augusta Foley, herself the author of *Buddhist Psychology* (1900), *Psalms of the First Buddhist* (1910) and other works.

**DAVIDSON, RANDALL THOMAS** (1848— ), Archbishop of Canterbury (see 7.863), in 1920 brought forward in the House of Lords a motion opposing Lord Birkenhead's Divorce bill, which was lost by one vote. The same year he presided over the sixth Lambeth conference.

**DAVIES, HENRY WALFORD** (1869— ), English organist and composer, was born at Oswestry, Salop, Sept. 6 1869. After a preliminary private education he became a chorister at St. George's chapel, Windsor, in 1882, and three years later assistant organist to Sir Walter Parratt there. From 1890 to 1894 he was a pupil and scholar at the Royal College of Music, where in 1895 he became a teacher of counterpoint. There he came first into some prominence as composer with his cantata *Herod Riel* (1894), but meanwhile he was making his way as organist. After filling several posts he was in 1898 appointed organist to the Temple church, a post he still holds (1921). During the years 1903 to 1907 he was conductor to the London Bach Choir in succession to Stanford, and in 1919 he was appointed professor of music in the University College of Wales, at Aberystwith. For a great part of the World War, with the rank of major, he worked with great success for the right organization of music among the troops both abroad and at home, and in 1918 he was made director of music to the R.A.F.

Walford Davies has written much music in many forms. In his list are two symphonies: *A Solemn Melody*, which attained to a wide popularity, and, for chorus and orchestra, *Everyman* (1904); *Ode on Time* (1908); *The Sayings of Jesus* (1911); *Dante Fantasy* (1914), these having been produced chiefly at provincial festivals; *Heaven's Gate* (People's Palace, 1917). A new choral work was in the programme of the Hereford festival for Sept. 1921. In addition there are seven quartets for various combinations of piano and strings, or strings alone; six violin sonatas and several works for voices and strings, part-songs, choruses, and hymn tunes.

**DAVIES, HUBERT HENRY** (1876-1917), English playwright, was born in Cheshire March 17 1876. After some years of journalism in San Francisco, where he also produced a few vaudeville, he returned to England and made a success at the Haymarket theatre in 1903 with *Consin Kate* and a greater success at Wyndham's theatre with *Mrs. Goring's Necklace*. Among his other comedies were *The Mollusc* (1907), and *Doormats* (1912). He produced *The Outcast* (1914). After overworking himself in France as a hospital orderly during the earlier portion of the World War, he had a break-down in health, and he was found dead at Robin Hood's Bay, Yorks., Aug. 17 1917.

**DAVIES, JOHN LLEWELYN** (1826-1916), English divine and educationalist, was born at Chichester Feb. 26 1826. He was educated at Repton and Trinity College, Cambridge, where he was bracketed as fifth classic in 1848, and was elected to a fellowship at Trinity in 1851. He was ordained in 1850 and held successively several London livings. He was made chaplain to the Queen in 1876, and in 1889 became vicar of Kirkby Lonsdale, Westmoreland, where he remained till 1908. Davies was

an intimate friend of John Frederick Denison Maurice (see 17.010), and was associated with him in the foundation of the Working Men's College (1854), where he taught for many years. He was elected to the first London school board in succession to Huxley, and in 1873 became principal of Queen's College, Harley St., which had been founded by Maurice in 1848 for the advancement of women's education. He held this post until 1874, and was again principal from 1878 to 1886. Davies died at Hampstead May 17 1916. He was part author of Davies and Vaughan's well-known translation of Plato's *Republic*.

**DAVIES, SARAH EMILY** (1830-1921), British educationalist, was born at Southampton April 22 1830. She was educated at home, and later identified herself with the movement for the higher education of women, being also one of a group of women who about 1858 were discussing the question of women's suffrage at the Kensington Society. In 1862 she became secretary to the committee which was formed for the purpose of procuring the admission of women to university examinations, and from 1870 to 1873 was a member of the London school board. In 1873 she was elected a life governor of University College, London, and in 1882 became secretary of Girton College, Cambridge, retiring in 1904. She published *The Higher Education of Women* (1866) and *Thoughts on some Questions relating to Women* (1860-1908, 1910). She died in London July 13 1921.

**DAVIES, WILLIAM HENRY** (1870— ), British poet, was born at Newport, Monm., April 20 1870. He was apprenticed to a picture-frame maker, but when his apprentice days were over he tramped through America, crossed the Atlantic many times on cattle boats, became a pedlar and street singer in England, and after eight years of this life published his first volume of poems, *The Soul's Destroyer*, from the Marshalsea prison. Next year appeared in prose *The Autobiography of a Super-Tramp* (1908) with a preface by G. Bernard Shaw, as well as *Nature Poems and Others*. A collected edition of his poems appeared in 1916, and *Forty New Poems* in 1918. He also published a novel, *A Weak Woman* (1911), and volumes of nature studies and essays, including *A Poet's Pilgrimage* (1918).

**DAVIS, HENRY WILLIAM BANKS** (1833-1914), English painter (see 7.866), died at Glaslyn, Radnorshire, Dec. 1 1914.

**DAVIS, RICHARD HARDING** (1864-1916), American writer, was born in Philadelphia April 18 1864. He studied at Lehigh University and Johns Hopkins, and in 1886 became a reporter on the *Philadelphia Record*. After working on several papers he served as managing editor of *Harper's Weekly*. He became widely known as a war correspondent, reporting every war from the Greco-Turkish War (1897) to the World War. Of his numerous works of fiction, the earliest are his best, especially *Gallegher and Others* (1891); *Van Bibber and Other Stories* (1892) and *Episodes from Van Bibber's Life* (1899). His other books include: *Soldiers of Fortune* (1897); *Captain Macclin* (1902); *Vera the Medium* (1908); *The Bar Sinister* (1904) and *With the French in France and at Salonika* (1916). His plays include *Miss Civilization*; *The Dictator*; *The Galloper*; *The Orator of Zapala City* and *The Zons Police*. He died near Mt. Kisco, N.Y., April 11 1916.

**DAVISON, HENRY POMEROY** (1867— ), American banker, was born at Troy, Pa., June 13 1867. He was educated at Greylock Institute, South Williamstown, Mass. He was successively errand-boy in the bank conducted by his uncle in Troy, Pa., runner for a Bridgeport (Conn.) bank and paying-teller in the newly opened Astor Place Bank in New York City, remaining there from 1891 to 1894. From 1894 to 1902 he was connected with the Liberty National Bank, New York, successively as assistant-cashier, vice-president and president. In 1902 he became vice-president of the First National Bank, and in 1907, following his activities during the panic of that year, he entered the firm of J. P. Morgan & Co., of which he was in 1911 still a member. In 1908 he was appointed adviser to the National Monetary Commission to investigate the financial systems of Europe. Later he served at the head of a group of American bankers interested in the Six Power Chinese Loan. From 1917



to 1919 he was chairman of the American Red Cross War Council. During his incumbency, \$300,000,000 was raised through popular subscriptions in aid of war sufferers. In 1919 he became first president of the newly formed international organization of all Red Cross bodies, the League of Red Cross Societies.

**DAWKINS, SIR WILLIAM BOYD** (1838— ), English geologist and archaeologist (see 7.873), was knighted in 1910.

**DAWSON OF PENN, BERTRAND EDWARD DAWSON**, 1ST BARON, English physician. He studied medicine at University College and the London hospital, where in 1896 he became an assistant-physician. He carried out extensive researches on gastric affections, and became one of the leading authorities on this subject. He was appointed physician extraordinary to King Edward VII., and later physician in ordinary to King George V. During the World War he did very valuable work on war diseases, publishing various papers on paratyphoid and infective jaundice. He was made G.C.V.O. in 1918, K.C.M.G. in 1919, and in 1920 was raised to the peerage. He has published *The Diagnosis and Operative Treatment of Diseases of the Stomach* (1908), besides contributions to Allchin's *Manual of Medicine*, and many papers in medical journals on gastric disorders.

**DAYLIGHT SAVING AND SUMMER TIME.**—The possibility of saving daylight in summer had been pointed out as early as 1784 by Benjamin Franklin in a paper, "Economic Project for Diminishing the Cost of Light," contributed to the *Journal de Paris*. The suggestion that the number of hours during which the use of artificial light is necessary should be reduced by advancing clocks during the summer months was made in Great Britain by the late Mr. William Willett. The first country in Europe to put the proposal into actual operation, primarily as a war measure, was Germany, and the example was followed by Great Britain and most European states; after its wide adoption in Europe, general attention to daylight saving was roused in America in 1916.

<sup>1</sup> In Great Britain, the question had been twice examined by a Select Committee of the House of Commons: in 1908, this Committee reported that "the object was desirable if it could be attained"; but, in 1909, "having regard to the great diversity of opinion as to whether the measure can be attained by legislation without giving rise, in cases involving important interests, to serious inconvenience," the Committee recommended that it should be dropped. In 1916, the need for economy especially in fuel and transport becoming urgent, the "Summer Time Act" was passed, prescribing that, during a period in each year, legal time in Great Britain should be 1 hr. in advance of Greenwich Mean Time, the precise incidence to be determined annually by Order in Council. The period in 1916 extended from 2 A.M. (Greenwich Time) on May 21 to 2 A.M. (G.T.) on Oct. 1 and, with the substitution of "Dublin" for "Greenwich" Mean Time, the bill also applied to Ireland. (Later, on Oct. 1 1916 Ireland adopted the same Standard Time as Great Britain.)

<sup>2</sup> In September 1916, in view of expressions of disapproval of certain sections of the community—agriculturists, munition and other factory workers, miners and others—the Home Secretary appointed a committee to inquire into the social and economic results of the Act. It reported to the effect that the small temporary inconvenience of the transition from normal to Standard Time and back were altogether outweighed by the saving in artificial light and by the general gain in health from the addition of an hour of daylight to the time for exercise and recreation. It therefore recommended the continuance of the Act in 1917 and subsequent years, the period for 1917 to be from the second Sunday in April to the third Sunday in September.

<sup>3</sup> In the United States, after several abortive attempts at legislation to apply to the country generally, a bill was introduced in Congress in 1918, passed both houses, and was signed by the President March 19. It provided that time throughout the United States should be advanced 1 hr. at 2 A.M. on the last Sunday in March and so continue until 2 A.M. on the last Sunday in October. This law was repealed in Aug. 1919 after two years' trial, but though the country as a whole repudiated daylight saving, certain eastern states still continued it.

<sup>4</sup> A new law in New York, passed in 1921, provided for local option, so that daylight saving could continue in New York City and several other cities. In Canada (though there was a strong rural feeling against it) Summer Time continued to be adopted in 1921, the U.S. and Canadian railways running to Standard Time. The Australian Senate repealed the Daylight Saving Act in 1917, and Spain ceased to adopt Summer Time in 1920. In 1918, the Egyptian Government reported against the scheme, which has, in fact, met with little support outside Europe and N. America.

Considerable opposition to the Act was manifested in Great Britain and still stronger in the United States. Among other things, it was alleged that children's sleeping hours would be curtailed; that vitality of body was reduced in the early hours. But reports of police authorities showed that the tendency throughout the country to spend the extra hour out of doors made for improvement in the moral tone, a marked decrease in juvenile offences was noted, and health committees saw no reason to suppose that workers were adversely affected. Many farmers believed erroneously that their former noon hour was the hottest part of the day, although the greatest heat is, in fact, from 2 to 3 hours later; more sound was the objection that the early morning hour was not favourable to farm (especially harvest) work because of the heavy dew, and had to be made good at the cost of overtime. Some complained that milking time was forced ahead abnormally. Confusion arose at first in the record of astronomical and meteorological observation and some series of observations were interrupted. City people as a whole were, however, strongly in favour of the measure, though some pointed out that many were forced to exchange a cooler morning sleeping hour for a warm early night hour. When Summer Time ceased to operate in the United States, some inconvenience was experienced by the reduction of the number of business hours common to the London and New York Exchanges. But saving of coal was probably in excess of the estimate of 2½ million tons in Great Britain, and in the United States the saving amounted to 1½ million tons during the 7 months' period in 1918.

**DEAF AND DUMB** (see 7.880).—In the census returns for England and Wales for 1911 the figures relating to the deaf and dumb were:—

	Total	Male	Female
Deaf . . . . .	26,649	10,640	16,009
Deaf and dumb . . . . .	13,427	7,192	6,235
Dumb . . . . .	1,695	975	720

432 persons were returned in the tables as blind and deaf, 64 as blind and deaf and dumb, and 55 others in various combinations of deafness, blindness, dumbness and feeble-mindedness. The questions asked in the schedule for the census for 1911 were as follows:—

"If any person included in this schedule is:—

- (1) Totally deaf or deaf and dumb,
- (2) Totally blind,
- (3) Lunatic,
- (4) Imbecile or Feeble-minded

state the infirmity opposite that person's name and the age at which he or she became afflicted."

The report stated that this was the first occasion on which an attempt had been made to obtain information regarding the deaf other than deaf-mutes. This was felt to be desirable both because at previous censuses many persons were returned as deaf who were not stated to be dumb, though the information was not sought for; and because of the progress made in the phonetic training of deaf-mutes, it was felt that reasonable exception might be taken as to the description as deaf-mutes of persons who, while remaining deaf, had the art of intelligible speech.

The variation in the terms of the census questions from those asked on previous occasions renders the task of comparison practically impossible, as the tabulated figures relating to deafness alone in previous censuses were those stated voluntarily and not in response to a direct question, and therefore obviously incomplete—

England and Wales	1881	1891	1901	1911
Deaf and dumb . . . . .	13,295	14,192	15,216	13,427
Deaf . . . . .	—	15,088	18,507	26,649

Referring to these figures the report states:—"It will be seen that in 1911 the proportion of deaf and dumb is lower than at any previous census shown in the table, the improvement being shown at nearly all the age-groups. Whether the last ten years only or the whole forty years are considered, the improvement is, as might be expected from the success of modern educative methods, much more marked in early than in later life." From 1881 onwards the census commissioners had stated that the returns are unreliable and in-

complete. In 1881—"We feel bound to point out how very incomplete are the returns which relate to these afflictions. We have done our best with these unsatisfactory data," etc. In 1891 the report characterized the statistics as "in all probability excessively inaccurate." In 1901 it was pointed out that the machinery of an ordinary census was but imperfectly adapted to furnish the required particulars with the degree of accuracy which is essential for statistical purposes; and in 1911 the report stated:—"We must submit that statistics of this nature obtained through a general population census are most unsatisfactory, firstly on account of the difficulty of framing a suitable form of inquiry defining the degree of disability, and secondly because the definition has to be applied by householders with no technical knowledge, who will interpret it in different ways, and many of whom have a natural reluctance to admit that they or their relatives suffer from any defect." But the choice of wording in the 1911 census schedule was particularly unfortunate and confusing, and might have been avoided if the department had been willing to ask or accept the advice of those bodies, such as the National College of Teachers of the Deaf, and the National Bureau for Promoting the General Welfare of the Deaf, which, for educational and social reasons, were anxious to secure reliable statistics relating to deafness and deaf-mutism in the United Kingdom. "Total deafness is comparatively rare, whether it is congenital or acquired, and even among the so-called 'deaf and dumb' it is generally recognized that there are from 15 to 25% with a useful amount of hearing. This fact and the unwillingness mentioned by the commissioners to the return of children who have fairly successfully been taught speech as 'dumb' presented difficulties which even experts, such as the responsible heads of institutions for the deaf, found it hard to overcome in any attempt to give accurate returns. For instance, if the 100 children in a school for the deaf were in the majority of cases neither 'totally deaf' nor 'deaf and dumb' (i.e. orally taught), what was the headmaster to do? Leave them out?—or insert them?—and, if the latter, where? Mr. B. St. Johns Ackers, the chairman of the statistics committee of the National College of Teachers of the Deaf, in his address before the Manchester Conference in 1911, laid down a broad principle—"statistics, to have their full value, should not only be accurate, full and reliable, but should be on the same plan in all countries. This should apply to census and school statistics," and as the fuller consideration of all forms of defect, not only as to treatment but also as to preventive measures, is now occupying the attention of the newly formed Ministry of Health, it is essential, if State funds are to be spent in collecting information, that such information should be of real value when obtained.

The difficulty of framing a suitable question or questions relating to so wide a subject as deafness and deaf-mutism, in a short and simple form, in the small space available on a census schedule, caused the department to omit any attempt to secure information of this kind from the 1921 census, and further statistics of this kind will not in future be available until some new machinery has been provided. This may be undertaken through the Ministry of Health, or, if undertaken with the assistance of the various educational and social organizations connected with the deaf and dumb, might secure figures not only relative to the actual existence, but also as to the causes of deafness, which might later prove of inestimable value in preventive measures, and so greatly reduce the number of this afflicted class in the community.

Indeed the medical inspection of school children has already begun to operate in this direction and the discovery of children suffering from causes which may lead to partial or total deafness is part of the ordinary routine of the school medical officers in the counties and county boroughs of the United Kingdom. In 1919 Dr. Hamar, chief medical officer to the London County Council, reported that at the school medical inspections 4,211 children (2.2%) were found to have ear disease, of whom 2,823 (1.4%) were referred for treatment, and the London County Council has now established six centres for the educating of children suffering from impairment of hearing short of "deafness" within the meaning of the 1893 Act. About 25% of the children attending these centres suffer from discharging ears and receive nursing attention under medical supervision.

In this connexion it is interesting to note that in a comparison of the conditions in 1915 and 1919 it was found that in the former year 2.1% of the children examined in London were found to be suffering from ear disease, whilst in the latter year there were only 1.85%. At Glasgow it was found that out of 500 cases of deafness and middle-ear disease, 26% originated in measles, 12% in scarlet fever, 29% in simple catarrh and 20% during dentition. Mr. Yearsley, the aurist of the London County Council, found

that of 177 cases certified by him to be deaf or hard-of-hearing, 37 were congenital, in 119 cases it was acquired, and in 21 doubtful. Of the cases of acquired deafness, 64 resulted from suppurative and middle-ear disease, 18 followed infectious fevers, 11 resulted from congenital syphilis and 20 followed meningitis. In the report of Dr. Butterworth (Lancs.) the general conclusions arrived at were that "deafness in school children is largely due to causes which can be removed by simple treatment, but this treatment can only be satisfactorily carried out in a clinic, where the child can attend regularly till it is cured"; and a further suggestion was made that "the ear, like the eye, must be brought under systematic supervision from infancy upwards."

In the report of the chief medical officer of the Board of Education for 1919 the position with regard to the schools was given as follows:—

	No. of schools		Provided	Voluntary	Accommodation	No. on registers
	England	Wales				
Deaf	49	2	37	14	4,622	3,493

In Scotland the latest figures available give 12 schools with accommodation for 1,014 children and 714 pupils in attendance; in Ireland 4 schools with accommodation for 580 children and 525 pupils. There was still no law for the compulsory education of the deaf of Ireland.

In the same report for 1919 the chief medical officer of the Board of Education made the following statement:—"The regulations of the board cover the educational needs of the child from the age of two years upwards, extending to the age of sixteen. From the age of two to the age of seven attendance is optional and only becomes compulsory at seven. The disadvantages of this statutory provision are considerable, and authorities are not as a rule willing to incur the heavy expense of special education so long as the law does not compel them to do so, and the deaf child is involved in a serious educational loss in consequence. The early beginnings of speech which come more easily to the deaf child are withheld from him to a later age and it may safely be said that the majority of the deaf children never make up for the loss sustained by postponing the beginning of education until seven, or, as often happens, till later."

This illiberal policy of depriving the deaf of the early years of instruction occasionally takes a more aggravated form when parents or local authorities, from reasons of economy, allow the children to remain away from school even after the statutory age of seven. In a return in 1920 it was found that among the children admitted to schools for the deaf 109 were eight years of age or older, 47 over 8; over 9, 28, over 10, 13; over 11, 10; over 12, 7; over 13, 3; over 14, 1. To remedy this evasion of the law a resolution was adopted at the conference of Teachers of the Deaf at Birmingham in 1920 asking that in cases in which the pupil was admitted later than the legal age the school period should be extended to secure to the child the full period of instruction. This would be in conformity with the practice in America, where many states provide a school period of from 10 to 12 years for their deaf pupils, irrespective of the age of entry.

The average attendance in England and Wales in the last school year (according to the report for 1919) was 3,325-2,355 in institutions and 970 in day schools. In 1920 Mr. Steary, chairman of the National College of Teachers for the Deaf, stated that of 2,600 children attending 32 of the schools, 170 were semi-mute (i.e. had become deaf after having acquired normal speech), 390 were partial hearing cases, 80 were mentally defective as well as deaf, 7 were blind and deaf, whilst 2,114 were ordinary cases of deaf-mutism. Referring to the methods of instruction, he gave the following statement relating to the year ended March 31 1920:—"The oral method largely predominates in our schools. The day schools are practically entirely oral, as are also several of the residential schools. In the cases of 2,816 children attending 34 schools, 2,494 are orally taught, 289 by finger spelling and 33 by finger and speech combined."

For the same period the returns of American schools, as published by the American Annals, showed that in 169 schools in the United States there were 13,779 pupils, of whom 10,376 were taught wholly or chiefly by the oral method, and a further 862 taught speech in combination with some other method—finger-spelling, or "signing." These figures prove the great advance which has been made in the attempt to remove the abnormality of the deaf. The deaf child of tender years is just like his brother or sister, except for his deafness, but as years pass with no auditory impressions and no development of speech, and the only means of communication open to him that of gesture, his intercourse is narrowed down to those immediately around him, and the divergence from the normal becomes

more and more marked unless special means are used to combat it. The possession of a verbal language in place of a language of gesture, particularly if that language is used in the form of articulate speech, even though artificially taught, and the ability to lip-read and the habit of looking to the face of the speaker for what is being said—all tend to lessen the abnormality induced by their affliction and to render the deaf more capable of taking their part in the workshop and the environment of their home in later life, than a specialized form of instruction such as finger-spelling or signing, known only to those expert in that means of communication.

The general recognition of this fact has led during the past half-century to an almost complete change from silent to oral methods in the majority of schools, both in Europe and America; though there were still in 1921 a few schools on both sides of the water where silent methods were adhered to, or where they formed the basis of ordinary means of intercourse, so that the oral work of the teachers was considerably nullified by the daily usage. A proportion, too, of deaf children in the schools is incapable of acquiring speech and a verbal language of sufficient range to be of practical use, either on account of poor intelligence, poor sight, lack of interest or general incapacity, whilst in some cases this incapacity is induced by the lateness above mentioned at which the children begin their education, so that it is impossible to overcome the "signing" habit and to substitute for it an intricate verbal language. This has led to a demand for a classification of the pupils of the schools for the deaf in order to secure for them that form of the education for which they are mentally and physically best fitted.

The discussion of the Danish system of classification of schools for the deaf at the international conference in Edinburgh in 1907 gave an impetus to this question in England, and after careful consideration of the question by teachers in London, and at the general conferences, it has now become an accepted principle that, in order to secure an advance in the success of the oral methods, and to give each child the best educational opportunity of which it is capable, the varying types of deaf children should be segregated into separate schools and institutions and only one method employed in any one school. A similar conclusion has been reached in American schools. At the meeting in 1920 of superintendents and principals of American schools for the deaf, Principal Jones, the head of one of the largest "combined" schools in the States, made the following statement:

"If I interpret the sentiment of the profession, and those interested in the deaf, correctly, it is that speech and speech-reading cannot be developed to the fullest extent of which they are capable in a congregated combined school. In a combined school there is always that lack of practice which makes it usable and effective. This, therefore, reduces to the lowest value all the efforts of the school and its hardworking teachers. The only remedy that I can see, after many years of laborious struggle to overcome it, is to separate the orally and manually taught children for as many years of their school life as is necessary to fix the speech habit."

Steps in this direction have been taken by the segregation of all backward and mentally and physically defective deaf children from the L.C.C. schools for the deaf to the residential school at Homerton (London), which in 1921 was about to be removed to new premises at Penn, Bucks., and by the establishment of Clyné House for the backward deaf at Manchester. At Homerton the combination of other defects, such as total or partial blindness, with deafness presents unique conditions for the study of psychological problems in conjunction with physiological abnormalities. The gradual removal of all younger pupils from the big institutions for the deaf has also been in operation, and the extension of the British Government regulations allowing children to be received from the age of "two" upwards will no doubt give an impetus to the establishment of infant and nursery schools for the deaf, where those "early beginnings of speech which come more easily to the young child" may have full play.

Provision of this kind had already, by 1921, been made at the Manchester, Doncaster and Margate institutions, at the Fitzroy Square (London), Moseley Road, Birmingham, and several L.C.C. day schools, to receive these younger children. The removal of partial-hearing and hard-of-hearing cases from the schools was also extended, and increased accommodation was being made for their special treatment, usually in connexion with one of the ordinary elementary schools. Classes have been established in Glasgow, Bristol, London and elsewhere, so that these children might not need to be brought into contact with the ordinary deaf-mute child. In these schools some amount of acoustic training is given, either by means of appliances or by the human voice alone, and the child is taught to supplement his partial hearing by "speech-reading," so that any hiatus caused by his lack of hearing may be overcome by his recognition of the spoken word on the lips. The children attend the ordinary school classes for such subjects as drawing, singing, etc., in which their partial deafness does not prevent their receiving the benefit of the instruction, whilst their association with the normal type of child prevents the growth of idiosyncrasies which might tend to increase their abnormality.

By a modification of the terms of Government regulations the State has now become responsible for 50% of the cost of the education of deaf children incurred by local authorities, and the remainder usually falls on the local rates, parents contributing towards the

cost of "maintenance" of the children far apart from education. Such sums as may be assessed by the local authorities, or, in the case of dispute, as may be fixed by magistrate's order. Thus the last vestige of the need of charity for the education of the deaf has been removed.

The Board of Education in England extended its regulations in 1920 to allow for the payment of grants for the training of young persons beyond the age of 16 in preparation for a trade who had previously been taught in a special school for the blind or deaf. This would enable certain advanced courses of instruction in technical knowledge to receive grants, which had hitherto been entirely supported by private means—such as the J. E. Jones Trade School for the Deaf at Manchester. No attempt had yet been made to establish a school for the higher education of the deaf, though the matter had been repeatedly endorsed as a desirable end to the educational effort for this class in Great Britain.

The organization of a course of training at the university of Manchester for teachers of the deaf was rendered possible by the generous benevolence of Sir James E. Jones, who endowed the Ellis Lloyd Jones lectureship in the teaching of the deaf and founded the Ellis Lloyd Jones Hostel as a hall of residence for women students. This for the first time in the history of the education of the deaf was become part of the work of an ordinary university. Bursarships have been established by various schools for the deaf and educational authorities, to enable students to take advantage of the training thus provided.

A liberal grant has been made by the Carnegie trustees to the university to establish a library of deaf education, and this is housed in a room in the Christie Library at the university, where the book can be consulted by students and others interested in the question on application to the library authorities.

The establishment in London in 1911 of the National Bureau Promoting the General Welfare of the Deaf was a step of the great importance. The famous "Volta Bureau," established in Washington, D.C., by Dr. Graham Bell, with the money he received for the "Volta" prize for the invention of the telephone, is well known and it is confidently expected that this National Bureau, founded through the generosity of Mr. Leo Bonn, will do for Great Britain even more than its American predecessor. Full particulars of the 60 schools and institutions for the deaf, the 60 or 70 missions to the adult deaf, and the 15 or 16 large organizations, all interested in the advancement of the deaf in various ways, have been filed at the bureau, and the council consists of representatives of every organization working on behalf of this afflicted class, both in child and adult life. The main objects of the bureau are: 1 (centralization), to get into touch with and promote cooperation between all existing agencies; 2 (information), to collect, classify, and disseminate information; 3 (investigation), to promote investigation. Statistics and particulars relating to every existing agency and institution working for the deaf in the United Kingdom have been collected and published by the bureau in a useful form, and these will be kept up to date as changes occur. When public bodies and private individuals realize that complete and accurate information on all matters connected with the deaf may be obtained through the bureau, it will become a "clearing-house" for this branch of effort.

Unfortunately, the outbreak of the World War occurred just as this bureau was becoming recognized as a valuable asset, and owing to the depreciation of its resources it had not been able by 1921 to resume the activities it was so ably carrying on in its early years. Under the auspices of the bureau, Dr. J. Kerr Love gave a series of lectures in London on "The Causes and Prevention of Deafness." These lectures have been published, and contain some valuable suggestions for the prevention of deafness both congenital and acquired by the notification and treatment of certain diseases as well as a full inquiry into the causes of hereditary deafness in Britain and America.

During the war special work for the deaf met with the same difficulties in Great Britain as beset every other branch of social effort. As a class the deaf were unable to take active part in military service, though here and there a few individuals managed to pass the medical tests and joined the Forces. Several attempts were made by bodies of deaf men in London, Liverpool and elsewhere to form volunteer units for service in some non-combatant capacity, but it was found impossible to secure recognition, probably owing to the great pressure with which the organizing officers of the army were working, and the matter languished for want of support. The fact that a number of deaf men went out with private firms and did useful work with hut building, etc., showed that there might have been useful units organized for this type of service if there had been time and inclination on the part of the officers to get them established. The great demand for labour of all kinds during the war brought about an unprecedented demand for the labour of the deaf members of the community in civil life, and for several years there was a greater appreciation of their economic value than had ever been accorded before. Unfortunately, with the general trade depression following the war there ensued a corresponding amount of unemployment, in which the deaf suffered in the same way as the hearing. The religious and social organizations working in behalf of the deaf also felt the lack of support which was being experienced by all charitable organizations up to 1921. With the exception of

one official in the capacity of work-seeker appointed by the Board of Trade, no State aid had been given to the deaf, but it was intended to apply for the inclusion of the deaf in the State provision which was set up for the training and employment of the blind.

As a result of the war a large number of wounded and disabled British soldiers and sailors were found to be suffering from deafness and from shell-shock, frequently accompanied by dumbness. In dealing with these men the experience of the schools for the deaf proved most valuable, and their organization and the services of their staffs were drawn on to teach lip-reading to the deafened men and to aid in the recovery of speech among those suffering from dumbness. The ordinary training in the methods of teaching articulation and speech-reading to deaf children was an excellent foundation on to which could be moulded the special requirements of the disabled men. Sir James Dundas Grant, at the head of a special aural board, was in charge of this department of the Ministry of Pensions, and had local expert and medical representatives in all parts of the country. Sir Frederick Milner and Mrs. A. J. Wilson were instrumental in establishing hostels for deafened soldiers to provide social clubs for the men whilst undergoing special treatment and training in speech and lip-reading. The necessity for such of this special organization had largely ceased by 1921, but the lip-reading classes were still being carried on in various parts of the country under the direction of the ministry.

The convocations of Canterbury and York in 1918 adopted resolutions recommending that the spiritual welfare of the deaf and dumb should become a definite part of the work of each diocese and should be supported from diocesan funds, but up to 1921 this had not taken general effect. Five ordained clergymen were in 1921 at work among the deaf of London and district and three in other parts of Great Britain, whilst in the various populous centres of the British Isles "missions" to the deaf and dumb are carried on by lay-readers and other workers. (F. G. B.)

**DEAKIN, ALFRED** (1856-1919), Australian statesman, was born at Melbourne Aug. 3 1856, the son of a coach proprietor. He was educated at the university of Melbourne and was called to the Victorian bar in 1877; but before that date he had already worked as a journalist, and he continued to contribute frequently to the press, especially to the *Melbourne Age*. He entered the Victorian Legislature in 1878 and first took office as Minister of Public Works and Water Supply (1883-6). In 1885 he became Solicitor-General and in 1887 he was senior representative for his Colony at the first Imperial Conference held in London on the occasion of Queen Victoria's Jubilee. He was a member of all the bodies formed to promote the Federation of Australia as well as of the delegation which proceeded to London with the Australian Commonwealth bill in 1900 and, as Attorney-General, he was included in Sir Edmund Barton's first Federal "Cabinet of the Captains" (1901-3), succeeding him as Premier of Australia. During his legislative career in Victoria he was active in promoting social legislation and an ardent advocate of preference in favour of Great Britain. This fiscal policy he pursued during his three Federal premierships (1903-4, 1905-8, 1909-10) and he was also a strong supporter of Australia's cooperation in Imperial defence, being responsible for the acceptance of the measure authorizing Australian naval construction in 1909 and for the invitation to Lord Kitchener to come to Australia to report on the question of defence. He also passed that year an Act enforcing military training upon all able-bodied citizens. He was the leading figure at the Imperial Conference in London of 1907. After 1910 he led the Opposition in the Australian Parliament until ill-health compelled his retirement in 1912. He always refused any titular distinction; but he was credited by many with being the most brilliant orator of the British Empire, and the enthusiasm which he evoked in London was great. He represented "Centre" thought in Australian politics and for a long time was a reconciling influence between the Conservatives and the Labour party. He died Oct. 7 1919.

**DEANE, SIR HENRY BARGRAVE FINNELLEY** (1846-1919), English judge, was born April 28 1846, the only son of the Rt. Hon. Sir James Parker Deane, K.C. He was educated at Winchester and Balliol College, Oxford, where in 1870 he won the international law essay prize. He was called to the bar in 1870, and was made a Q.C. in 1896. From 1885 to 1905 he was recorder of Margate, and in 1905 was raised to the bench and knighted. From 1892 onwards his work lay mainly in the Probate, Divorce and Admiralty division. In 1917 he retired from the bench, and he died in London April 21 1919.

**DE BROQUEVILLE, CHARLES, COMTE** (1860- ), Belgian statesman, was born at Tostel, Belgium, Dec. 4 1860 of a family which was French in origin. He was privately educated and passed much time at his father's estate. It was his marriage to Mlle. d'Huart, granddaughter of Jules Malou (see 17496) the Conservative leader, that paved the way for his entrance into public life. At the age of 25 he became a member of the provincial council of Antwerp, subsequently being elected deputy for Tournhout, and in Aug. 1910 was appointed Minister of Railways, Posts and Telegraphs in the Schollaert Cabinet. On the fall of this Ministry (July 1912) Baron de Broqueville undertook the formation of a new Cabinet, and in Nov. 1912 also became Minister of War, in this position successfully pressing through the bill for strengthening the Belgian army. When in Aug. 1914 the Belgians determined to resist the passage of the Germans through their country, the Belgian premier well expressed the feelings of the nation in his declaration "Nous serons peut-être vaincus, mais soumis, jamais!" On the retreat of the Belgian army towards the Yser, De Broqueville established himself at Dunkirk and there assisted the military authorities to re-create the units of the Belgian army which had been broken in the retreat. He established the Belgian base at Calais, and after the battle of the Yser worked indefatigably for the re-constitution of the army. In Aug. 1917 Gen. de Ceuninck became Minister of War and De Broqueville succeeded Baron Beyens as Foreign Minister. One of his more important actions was to establish a war Cabinet of six members on the model of those in France and England. In Jan. 1918, however, he was succeeded as Foreign Minister by M. Paul Hymans, already a member of the war Cabinet. It was found that in Sept. 1917 De Broqueville had transmitted to M. Briand peace proposals secretly made by the Germans through Voer der Lancken, head of the political department in Brussels, without informing his colleagues in the Cabinet, and this incident seriously diminished his power. In Jan. 1918 he took over the charge of the new department of national reconstruction, but in June of the same year his resignation of the premiership was accepted by the King. At the end of the war he became Minister of the Interior in the Delacroix Cabinet, and retained this office until Nov. 1919, when he retired, having the same year been created a count.

**DEBS, EUGENE VICTOR** (1855- ), American labour leader and socialist, was born at Terre Haute, Ind., Nov. 5 1855, of Alsatian parents. On leaving the public schools he became in 1871 a locomotive fireman, and four years later took a position in a wholesale grocery. In 1879 he was elected city clerk of Terre Haute on the Democratic ticket, and in 1881 was re-elected. During 1885 he was a member of the Indiana Legislature. Meanwhile, in 1880 he was elected secretary and treasurer of the Brotherhood of Locomotive Firemen and was chosen editor of the *Locomotive Firemen's Magazine*. When the American Railway Union was organized in 1893 he was elected president, serving four years. Under his leadership a strike on the Great Northern railway was won in 1894. The same year he led the strike which, beginning in the Pullman car plants, soon involved the railways leading into Chicago (see 6.124). Debs was arrested on the charge of conspiracy to kill, was acquitted, was later convicted of contempt of court for violating an injunction, and was sent to gaol for six months (May-Nov. 1895). At this time his study of socialism began, and in 1897 he allied himself with the movement, for a year acting as chairman of the National Council of the Social Democracy of America. After this was reorganized into the Social Democrat party in 1898 he was an influential member. In 1900 he was Socialist candidate for president of the United States, receiving 96,116 votes; was again candidate in 1904, 1908 and 1912, but declined the nomination in 1916. In 1907 he was appointed on the editorial staff of the *Appeal to Reason*, and his contributions attracted wide attention. In 1914 he became editor-in-chief of the *National Rip-Saw*, a socialistic paper published at St. Louis. After America's entrance into the World War he upheld pacifism, and in Sept. 1918, after a speech at Canton, O., he was charged with violation of the Espionage Act, was convicted, and sentenced to serve 10

years in the penitentiary. The sentence was upheld by the U.S. Supreme Court March 10 1919, and he entered prison April 13. In 1920, although still imprisoned, he was again nominated presidential candidate by the Socialists and received 915,302 votes, ranging from 25 in Vermont to 203,400 in New York. He was released on Christmas Day 1921, his sentence having been commuted by President Harding, but his forfeiture of rights of citizenship was not affected. He is the author of *Unionism and Socialism: a Plea for Both* (1904); *Liberty*; and *Industrial Unionism* (1911).

**DEBUSSY, CLAUDE ACHILLE** (1862-1918), French composer (see 7.906), died in Paris March 26 1918.

**DE FILIPPI, FILIPPO** (1869- ), Italian scientist and explorer, was born at Turin April 6 1869. He studied medicine at the university of Turin, and became an assistant in the surgical clinic of the university of Bologna, occupying later the same position at Genoa. He subsequently became reader in operative surgery at Bologna, and pursued researches of great value in physiological and biological chemistry. In 1897 he joined the expedition of the Duke of the Abruzzi to Alaska as scientific observer, and took part in the ascent of Mount St. Elias. In 1906 Signor de Filippi again accompanied the Duke of the Abruzzi on an expedition to the Ruwenzori range of central Africa. The first detailed map of the higher part of this mountain region was a result of this journey, together with many valuable geological and other observations. In 1909 de Filippi went with the Duke's expedition to the western Himalaya and Karakoram mountains, when a peak 24,600 ft. in height, close to Mount Godwin-Austen, or K2, was ascended. He later (1913-4) organized and led an important scientific expedition to the Karakoram mountains and central Asia, under the auspices of the Indian and Italian Governments, and for his valuable investigations received in 1916 an hon. K.C.I.E. from the Indian Government. He has also received many honours from British and foreign scientific societies, and is a gold medallist of the English and Italian Royal Geographical Societies. During the World War he served in the Italian army medical service, and also lectured in England on subjects connected with the war.

He has published *The Ascent of Mount St. Elias* (1900); *Ruwenzori* (1909) and *Karakoram and Western Himalaya* (2 vols. 1912), besides many papers in scientific journals.

**DEGAS, HILAIRE GERMAIN EDGARD** (1834-1917), French painter (see 7.931). The Impressionist years, in which such typical canvases as "Women in a Café" and "Danseuses à la Barre" (sold in 1912 for 119,100 francs) showed Degas's complete break with the academic painters, his realistic outlook, and his mastery of *maîtrise*, notably pastel, ended with the eighth Impressionist Exhibition 1886, where he continued his realistic studies of modern life, showing drawings of the nude, of work-women, and of jockeys. This marked his withdrawal from all public exhibitions. In the following years, until his death in 1917, Degas mainly concentrated on drawings and pastels of the nude, chiefly women at their toilets or in the bath, interspersed with returns to his favourite ballet subjects. At one time he almost abandoned the use of colour but returned thereto later. In his last years, ill-health and a forced removal from his studio prevented his working. Besides pastel and oil colour Degas also handled his favourite subjects in etching, aquatint and lithography. His work is to be seen in the Luxembourg (Caillebotte collection), the Louvre (Camondo collection), the Victoria and Albert Museum, the Tate Gallery, the British Museum, Boston (U.S.A.) Museum, the National Gallery, Berlin, and many private collections. Though closely associated with the impressionists and showing their sensitiveness to atmospheric colour, Degas was never one of them. An admirer of Ingres, and the great classical draughtsmen, he was himself a classic in his impersonal outlook. The increasing preoccupation of his art was the expression of form, chiefly by line, and to this must be ascribed his later concentration on the nude and temporary abandonment of colour. His figures are never impressions, but an elaborate synthesis of many sketches and much observation. An uncompromising realist in his subjects, Degas found in the art of

the Far East a starting-point for combining the most ordinary and ungraceful attitudes of everyday life into an original, intricate and harmonious design.

See also P. Lafond, *Degas* (1928); A. J. Meier-Graefe, *Degas* (1920).

**DELAGE, MARIE YVES** (1854-1920), French zoologist, was born at Avignon May 13 1854. He became a member of the French Academies of Science and Medicine, professor of zoology at the Sorbonne, Paris, and a Chevalier of the Legion of Honour. He was one of the first authorities on animal reproduction and questions of hybridism and heredity (see 23.116, 14.27, 22.478). For his exploit in keeping alive in 1886, in a tank at Roscoff, a specimen of *Leptocephali* until it developed into a conger, see 9.9. He died in Paris Oct. 8 1920.

**DELAGO A BAY**, Portuguese East Africa (see 7.942).—Improvements in port accommodation during 1910-21 were mainly in connexion with the transit trade with the Transvaal and the development of the coal trade. Coaling plant was erected in 1914-5 and other plant added in 1921, so that altogether 1,400 tons per hour could be loaded direct into ships' holds. A new ferro-concrete wharf, 1,614 yd. long, was completed in 1916. The wharf was amply provided with electric and steam cranes. In 1920 the building of a dry-dock was begun. Dredging vessels maintain a minimum depth of 2½ ft. over the bar. Lourenço Marques drained, given a good water supply, and largely rebuilt, had become by 1920 one of the finest cities in South Africa. Considerable sums had been spent in making marine drives and golf links, in erecting hotels and in other measures to convert the suburbs, notably Polana, into health and holiday resorts in the winter months (May-Sept., average temp. 64° F.). Pop. of Lourenço Marques (1912 census) 13,353—of whom 5,324 were whites, including 668 British. Pop., city and suburbs (1920 estimate) 20,000.

The convention of April 2 1909 between the Transvaal and Mozambique provided (for a period of 20 years) for free trade in the products of the two provinces and for facilities for the recruitment of natives of Mozambique for labour in the Rand mines (from 80,000 to 100,000 Portuguese natives are normally employed in the mines). In return Delagoa Bay was to be given 50 to 55% of the railway traffic in the areas of the Transvaal in which it competed with Union ports, *i.e.* Durban. This was an effort to adjust conflicting political and economic factors. Had Delagoa Bay been a British port it would have had nearly all the trade of the so-called competitive area, the route from it to Johannesburg being not only some 100 m. shorter than the route to the Rand, but having easier gradients. During 1910-12 the division of traffic favoured Delagoa Bay. Rate adjustments followed and the share of Delagoa Bay in 1916 fell to 31% and thereafter showed no marked recovery. A proposal made by Senhor Freire d'Andrade (sometime governor of Mozambique) that the part of the province S. of the Sabi river—including Delagoa Bay—should join the South African Customs Union found supporters but was not adopted, and pending a new settlement the Mozambique Convention continued in force.

The following table shows the value of imports into and exports from the Union of South Africa via Delagoa Bay in the years named:—

	Imports.	Exports.
1909	£4,826,000	£ 253,000
1913	4,551,000	740,000
1918	2,308,000	1,100,000

Coal bunkered at Delagoa Bay was 136,000 tons in 1912; rose to 426,000 tons in 1917-8 and fell to 251,000 tons the succeeding year. In the same period (1912-9) the coal exported rose steadily from 179,000 to 589,000 tons. Most of the coal exported goes to Indian ports. The coal comes almost entirely from the Witbank mines, Transvaal. Besides coal Delagoa Bay receives from the Transvaal for export copper, tin, asbestos and maize. The export of copper on a considerable scale dates from 1913. It quickly attained the first place in regard to value (£573,000 in 1916 compared with £199,000, the value of the coal exports the same year). Exports of commodities produced in the province developed slowly. In 1913 they were worth £162,000, the chief item being sugar (£62,000); they fell during the period of the World War. Imports for consumption in the province reached the value of £1,083,000 in 1912.



Shipping remained mainly in British hands, though between 1905 and 1913 German shipping increased by 60%. In that year British shipping was 66 and German 18% of the total. After 1914 the shipping was almost wholly British and Portuguese. In 1917 the vessels cleared numbered 736. The Union of South Africa maintains an agency at Lourenço Marques.

The *Manual of Portuguese East Africa* (1920), a British Admiralty publication, gives useful information in respect to the relations of Delagoa Bay to the Transvaal. (F. R. C.)

**DE LA GORCE, PIERRE** (1846- ), French historian, was born at Vannes June 29 1846. He devoted himself to the study in particular of the history of the 19th century, and produced various works of much learning, the chief being *Histoire de la Seconde République Française* (1887), *Histoire du Second Empire* (1896-1905) and *Histoire religieuse de la Révolution* (1909). He was in 1914 elected a member of the French Academy, and in 1918 published a monograph, *Deux Frères: André et Pierre de Gaillard-Bancaz*.

**DELAND, MARGARET WADE** (1857- ), American writer, was born at Allegheny, Pa., Feb. 23 1857. She studied in private schools and at Cooper Union in New York, and for a time was a teacher of drawing. She lived in Boston after her marriage in 1880. She appeared as a writer of graceful verse in *The Old Garden* (1887), and in 1888 attracted wide attention with her first novel, *John Ward—Preacher*. This story resembles in theme Mrs. Humphry Ward's *Robert Elsmere*, at that time a centre of discussion. In all her works she deals with religious and social questions, and at first evoked protest in some quarters. Her method is perhaps best seen in *Sidney* (1891); *Philip and His Wife* (1894); *The Awakening of Helena Richie* (1906) and *The Iron Woman* (1912). Her numerous works include *The Story of a Child* (1892); *Old Chester Tales* (1899); *Dr. Lavendar's People* (1903)—in Dr. Lavendar some have seen a character comparable with Goldsmith's Dr. Primrose; *Partners* (1913); *The Rising Tide* (1916); and *The Promises of Alice* (1919), the romance of a New England parsonage.

**DE LA REY, JACOBUS HERCULES** (1847-1914), Boersoldier (see 7.944), who was concerned in the rebellion headed by Col. Maritz (see SOUTH AFRICA), was shot dead by a police patrol at Johannesburg, Sept. 15 1914.

**DELAUNAY-BELLEVILLE, LOUIS** (1843-1912), French engineer, was born at Corbeil Nov. 20 1843. Educated at St. Barbe and the Ecole Polytechnique, he entered the Naval Engineering school in 1864 and in 1867 left to join the Belleville works at St. Denis, near Paris. He became a partner and finally head of the firm which produced the well-known Belleville boilers (see 4.145), and also the automobile called by his name. From 1890 he was president of the Paris Chamber of Commerce. He died at Cannes Feb. 10 1912.

**DELAWARE** (see 7.947).—In 1920 the pop. was 223,003, as compared with 202,322 in 1910, an increase of 20,681, or 10.2%. The number per sq. m. in 1920 was 113.5; in 1910, 103. In 1920 the native whites constituted 77.5% of the total, foreign-born whites 8.9%, and negroes 13.6%. Of 10,508 illiterates in 1920, 4,700 were negroes, 3,373 foreign-born whites, and 2,427 native whites. In 1920 for the first time the urban pop. exceeded the rural; urban 120,817, or 54.2%; rural 102,186, as compared with 97,085 or 45.8%, and 105,237 respectively in 1910. The change was due chiefly to the growth of Wilmington, as Kent and Sussex counties remained strongly agricultural. One county, Newcastle, showed an increase, the other two decreases. Wilmington, a centre of war-time manufactures, had in 1920 a pop. of 110,168, as compared with 87,411 in 1910, an increase of 22,757, or 26%. The pop. of the other chief towns in 1920 was as follows: Dover, the state capital, 4,042; Newcastle, 3,554; and Milford, 2,753.

**Manufactures.**—Delaware, especially Wilmington and the upper end of the state, was influenced by the great industrial activity of the World War period. Most noteworthy was the part taken by the duPont powder interests in supplying the needs of the Allies. The following table gives interesting comparisons between the pre-war period and the year following the Armistice.

	1919	1914	1909
Number of establishments	668	808	726
Proprietors and firm members . . . . .	593	735	722
Salaried employees . . . . .	3,344	2,643	2,024
Wage earners (average number) . . . . .	29,035	22,155	21,238
Capital . . . . .	\$148,207,598	\$69,323,927	\$60,905,671
Salaries . . . . .	7,709,068	3,399,568	2,322,329
Wages . . . . .	37,265,319	11,382,160	10,295,396
Cost of materials . . . . .	85,432,938	31,649,263	30,937,801
Value of products . . . . .	165,073,009	56,034,966	52,839,619
Value added by manufacture . . . . .	79,640,076	24,385,701	21,901,818

In 1919 the principal industries were leather, pulp goods, cars and general shop construction and repairs by steam railway companies, iron and steel, canning and preserving of fruits and vegetables, and foundry and machine-shop products.

**Agriculture.**—After the passage of the Agricultural Extension Act (1911) the most significant movement was the development of cooperative associations, and especially (1918-21) the rapid growth of the Farm Bureau movement. In 1920 the number of farms was 10,140, as compared with 10,836 in 1910, a decrease of 696, or 6.4%. The preceding decade had shown an increase of 1,149, or 11.9%. The value of all crops for Delaware, in 1919, was \$23,058,906. The total value of cereals was \$9,638,010; of hay and forage crops \$4,366,174; of vegetables, including potatoes, \$6,271,714; and of fruits and nuts \$2,566,807. As compared with 1910, the total value of all crops showed an increase of 166.6%; cereals 105.4%; vegetables 242.2%; and fruits and nuts 188.3%. These figures, of course, reflect the changed price level. The production of strawberries for 1919 was 4,362,473 qt., of apples 600,286 bus., of peaches 227,375 bus., and of grapes 1,445,121 pounds. The total value of live stock, horses, mules, cattle, swine, in 1919 was \$7,373,260; of dairy products, excluding "cheese sold" (not reported), \$2,442,253.

**Education.**—The most distinctive development in the decade beginning in 1910 was in the field of education. There was much discussion of educational matters, and an aroused public interest led to various measures for the strengthening of the public-school system. In 1913, a summer school was established for the training of teachers, and four years later the state agreed to pay the expenses of teachers in attendance. In 1913, also, the Women's College of Delaware was founded, affiliated with Delaware College, with the same president and board of trustees and in part the same faculty, but entirely separate in buildings, classes, and student organization. Delaware College showed rapid expansion. It had property worth \$1,800,000 (1921), and an income of \$382,000 (1920). The enrolment (1921) was 478,178 women and 300 men, not counting 80 ex-service men in vocational agricultural work. After 1913, following reorganization and reincorporation, the college was solely a state institution. In 1917 a commission was appointed to investigate educational conditions, and to recommend plans for unifying, revising and developing the public-school system of the state. The commission employed the General Education Board of New York to make this survey, and the results, when presented to the Legislature in 1919, were crystallized in the "New School Code." The advantages claimed were: (1) the codification of the whole body of school law; (2) definite and fixed responsibility of school officials; (3) a modern and fairer system of taxation; (4) a carefully graded system of schools; and (5) a normal school year of 180 days (or pupils from 7 to 14 years of age). The whole plan centred in a state Board of Education, composed of five members, with a state commissioner subordinate to them. Also, there were county boards and county superintendents in each of the three counties. In 1920, however, this system was considerably modified in the direction of lower taxation and greater local control, and in 1921, because of these influences, the ultimate fate of the Code seemed very uncertain. Wilmington grew so rapidly that its government, utilities, educational institutions, etc., were no longer adequate to its needs. In 1921 the city schools were surveyed under the direction of the national Bureau of Education and many needed reforms pointed out. At the same time proposals were being made for a new charter, providing for a commission form of government and a city manager.

**Finances and Taxation.**—The state system of finances and taxation underwent considerable modification and extension. After 1917, Delaware raised and spent about \$1,500,000 annually. For a number of years previously the state's expenditures exceeded the revenues, but at the close of 1918 the balance in the general fund was \$33,692.89, and on Jan. 1 1920 the balance was \$1,367,733.57. This swift change was due both to the creation of new sources of revenue and to the increased returns from old sources, especially the latter. The railway tax was established in 1897, the



corporation tax in 1899, the automobile tax in 1907. One new source of revenue was the state income tax of 1917, the first \$250,000 of this going to the school fund, the surplus, if any, to the highway department. In 1917, also, the collateral inheritance tax was changed to a direct graduated inheritance tax, with a consequent revenue for 1919 of \$199,033. Apart from these sources increased sums came from fees and from the corporation, automobile and franchise taxes. The much-discussed corporation tax became the state's main reliance as a revenue producer. A state banking department was created (1919), with a banking commissioner and a deputy, whose duty it was to examine every bank at least once a year. In 1917 the budget plan was adopted for a two years' trial, but in 1919 it was not continued. In 1921 the plan was again under discussion with a reasonable chance of adoption. State finances were reinforced by the "Federal Aid" revenue. In 1919 the receipts from the Federal Government were \$135,294.52, distributed as follows: (1) \$50,000 to Delaware College under Federal grants; (2) \$9,472.69 for vocational education; (3) \$75,821.83 for road construction.

*History.*—The two dominant facts in the history of the state in the period 1910–20 are: (1) the passage of a considerable number of modern and progressive laws, and (2) the reaction of the state to the strenuous demands and activities of the World War. In the latter respect, Delaware met the situation squarely and was well organized, with the various war-time activities centred in the state Council of Defense, of which Secretary of State E. C. Johnson was the directing spirit. The number of troops furnished by the state in the World War was 7,484, and the amount raised in Liberty and Victory loans \$103,898,350. In this period two progressive governors, Charles R. Miller and John G. Townsend, by their qualities of leadership, accomplished much for the state. During the administration of the latter, for example, a number of important statutes were enacted, including a Child Labor law (1917), a Workmen's Compensation Act (1917), laws for the regulation of hours of labour for women, an Income Tax law (1917), a Direct Inheritance Tax law (1917), an Act creating a state banking department (1919), and a thorough revision of the school laws, known as the New School Code (1919). These Acts, together with the Agricultural Extension Act (1911), mark a new era in the development of the state. After 1910 the Republicans maintained their control of state affairs, electing the following governors: Simeon S. Pennewill (1909–13); Charles R. Miller (1913–17); John G. Townsend (1917–21); and William D. Denny (1921–). Much of the time, however, the Democrats controlled the House of Representatives, and in 1916 they elected part of their state ticket. In 1921 the senior U.S. senator, Josiah O. Wolcott, was a Democrat, the junior senator, L. Heisler Ball, a Republican. In the presidential election of 1921 the Democrats carried the state, in 1916 and 1920 the Republicans won by a considerable margin. A third characteristic of the period should be mentioned. Public-spirited citizens of the state contributed large sums for education, for public highways, for child welfare, for charitable purposes, and for other worthy causes. It has been estimated that the gifts of Mr. Pierre S. duPont to public education total \$3,653,540.35. Gen. Coleman T. duPont completed and presented to the state a modern highway 20 m. in length, extending from Shelbyville to Georgetown. Under a state highway commission this work was extended by a magnificent system of highways, either under construction (1921) or projected.

See Henry C. Conrad, *History of Delaware*, 3 vols. (1908); Edgar Dawson, "Public Archives of Delaware," in *The Annual Report of the American Historical Association* for 1906, II, pp. 129–148; Adelaide R. Hasse, *Index of Economic Material in Documents of the States of the United States, Delaware, 1789–1904* (1910); Amandus Johnson, *The Swedish Settlements on the Delaware*, 2 vols. (1912); *Delaware School Code* (1920).

**DELBRÜCK, HANS (1848–)**, German historian (*see* 7,952).—Under the old regime Prof. Delbrück vigorously opposed the policy of the Prussian Government in dealing with the Danes and the Poles, with the result that he was twice subjected to disciplinary penalties as a professor and therefore, in Prussia, a civil servant. From 1889 to 1920 he edited the *Preussische Jahrbücher*, the most important political magazine in Germany. He was the author of a great number of articles and works, of which the following were published after 1910:—*Numbers in History* (1913); *Regierung und Volksville* (1914); *Bismarcks Erbe* (1915); *Krieg und Politik* (1918); *Kautsky und Harden* (1920) and *Ludendorff, Tirpitz, Falkenhayn* (1920). Special attention may be called to the book *Regierung und Volksville*, in which Prof. Delbrück attempted a defence of the old system of government in Germany and Prussia with particular reference to its "dualism," i.e. parliamentary representation and simultaneously a certain degree of autocracy on the part of the sovereign in Prussia and of the federated Government in the empire. At an early stage of the World War he became pessimistic regarding the possibility of any real success for

Germany except by military and political strategy and tactics of a purely defensive character. He was, on tactical rather than on moral grounds, a strenuous opponent of intensified submarine warfare, and did not conceal his conviction that the result of this method of warfare would ultimately be the intervention of America. After the Armistice of Nov. 1918 he devoted himself mainly to endeavours to prove that Germany could not be made solely responsible for the outbreak of war, although she had formally declared war upon Russia and France. He was one of those who were sent to Versailles during the Peace Conference in order to draw up a statement of the German case with regard to the responsibility for the outbreak of war.

For a succinct statement of Prof. Delbrück's views on this subject and an English reply see articles by Delbrück and J. W. Headlam-Morley in the *Contemporary Review* (March 1921).

**DELCASSÉ, THÉOPHILE (1852–)**, French statesman (*see* 7,953), returned to office in the Monis Ministry of Feb. 1911, as Minister for the Navy, a post which he retained when Caillaux succeeded Monis, and in the Poincaré Cabinet which was formed on Jan. 9 1912 after the fall of Caillaux over the Moroccan negotiations. He was appointed ambassador in St. Petersburg on Feb. 20 1913, and became once more Minister for Foreign Affairs in the reconstructed Viviani Cabinet on Aug. 26 1914. In this post he was actively concerned in counteracting the efforts of German diplomacy throughout the world, and particularly in England. He resigned from the Cabinet on Oct. 4 1915, partly on account of differences of opinion as to the advisability of proceeding with the dispatch of the expedition in Salonika in the changed conditions created by the resignation of M. Venizelos, and partly on the grounds of ill health.

**DELHI, India (see 7,954).**—The planning and laying-out of a New Delhi has been in progress since 1912, as the outcome of the official transfer of the capital of British India to Delhi from Calcutta, announced by the King-Emperor George V. at the Coronation Durbar on Dec. 12 1911. Two inauguration stones were laid by the King-Emperor himself on Dec. 15 1911, when he said: "It is my desire that the planning and designing of the public buildings to be erected will be considered with the greatest deliberation and care so that the new creation may be in every way worthy of this ancient and beautiful city." The first step taken was the appointment of a town-planning committee to advise on the choice of a site for, and a layout of, the new capital. This committee consisted of Capt. G. S. C. Swinton (chairman), Mr. J. A. Brodie and Sir Edwin Lutyens. Mr. V. Lanchester was subsequently consulted by the Government on certain aspects of the question. After a full consideration of all possible sites near the existing city of Delhi on which a new capital could be built, they found two alternative sites, known respectively as the Northern and Southern Sites—the former to the N. of Delhi and to the W. of the range of rocky hills which run S.W. from near the village of Wazirabad (3½ m. N. of the Kashmir Gate), giving a belt of land gradually increasing in width from W. to E. between the hills and the river Jumna; and the latter to the S. of Delhi and to the E. of this range.

The committee's first report was issued on June 13 1912, and with regard to the Northern Site, on which the Durbar camps of 1911 had been pitched and where the inauguration stones were laid, they found it had some general advantages.—This area is upwind and upstream of the existing city of Delhi; the ruins of the Delhi of the past do not cumber the ground; whilst external communications might need improvement, the area is fairly well served by existing railways; roads, canals and internal communications could be made convenient without excessive expenditure, and a good deal of money had already been spent on the area in connexion with the Durbar. But its disadvantages were found to be overwhelming.—the site was too small for the proposed new city, and part of the area was liable to flooding.

The committee therefore recommended the site on the eastern slopes of the hills to the S. of Delhi, on the margin of the area occupied by the Delhi of the past. They found this site free from liability to flooding, with a natural drainage. It was

# DELHI

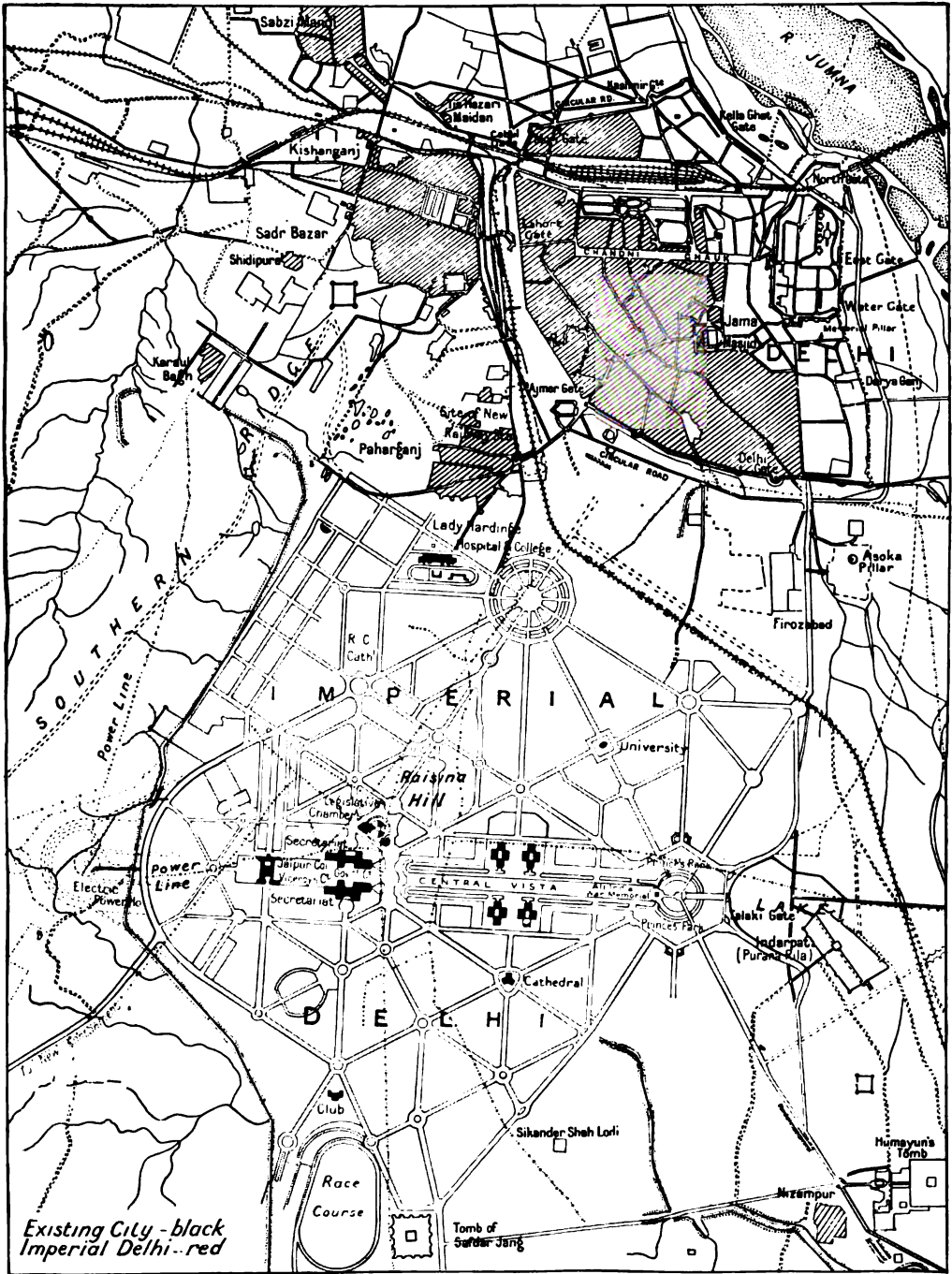

Existing City - black  
Imperial Delhi - red

0 1/4 1/2 3/4 1 2 3 MILES



not too much cumbered with monuments and tombs needing reverent treatment and, whilst it was reasonably near the centre of the existing city, it was capable of almost indefinite expansion southward. The committee had also examined other areas in the neighbourhood but found none suitable for the purpose. No good site existed E. of the Jumna. Similarly the Naraina Plain, on the western slopes of the hills to the S. of Delhi, was not recommended mainly because a new city built there could hardly be considered to be Delhi at all, and the area was destitute of historical associations and shut out by the hills from all view of the existing city. This area was, however, found suitable as a site for the new cantonment.

The publication of this first report aroused considerable interest both in India and in England. Articles in the Indian press expressed a preference for the Northern Site, a predilection which had also been felt by the town-planning committee when they commenced their labours. In Dec. 1912 Sir Bradford Leslie read a paper before the Indian section of the Royal Society of Arts in London, in which he set forth plans for building the new capital on the Northern Site and producing a fine water effect by a treatment of the river Jumna. The town-planning committee therefore, in Feb. 1913, issued their second report, in which they restated the arguments for and against the Northern Site.

"The soil is poor on the Northern Site as compared with the Southern. The Southern Site is already healthy and has healthy surroundings. The Northern Site, even after expenditure on sanitary requirements, will never be satisfactory. If the Northern Site is to be made healthy, this involves going outside the site itself and making the neighbourhood healthy also. The building land to the S. is generally good. On the N., to be used at all, it has in places to be raised at considerable cost. There is no really suitable healthy site for a cantonment in proximity to a city on the Northern Site. The exigencies of fitting in the requirements to the limited area of the Northern Site endanger the success of a layout as a whole and tend to make for cramping and bad arrangement. The result of placing a city on the Northern Site appears to the committee to be the creation of a bad example in place of a good one."

In Feb. 1913 a committee was appointed to consider the comparative healthiness of the Northern and Southern Sites. The committee reported on March 4 1913 "that no doubt can exist as to the superior healthiness of the Southern Site, the medical and sanitary advantages of which are overwhelming when compared with those of the Northern Site." The committee therefore, on March 20 1913, issued their final report with a layout for the proposed new city on the Southern Site.

The focal point of the new city (see map) is located on Raisina Hill, and the buildings of the Government Centre are arranged symmetrically about what is practically an E. and W. axis connecting the focal point with the northwestern or Talaki Gate of the old fort of Indrapat or Purana Kila. The two great blocks of secretariats are situated to the N. and S. of this focal point, with Government Court between them. Westward from Government Court, a raised platform or forum connects Raisina Hill with the high ground of the southern ridge, so that the whole Government Centre appears to be built on a spur of the ridge itself. This raised forum is known as the Viceroy's Court and at the western end of this court is situated Government House. The Viceroy's Court is also reached both from the N. and S. by roadways with easy gradients and, at the intersection of these roadways with the E. and W. axis of the court is placed the Jaipur Column surmounted by the Star of India.

Government House itself is also approached both from the N. and S. along fine avenues and to the westward of these avenues lies the viceregal estate, with its gardens and parks, wherein are located the bungalows of the viceroy's private and military secretaries, and the surgeon and comptroller, the quarters for the viceroy's troops and bodyguard and for other staffs connected with the viceregal estate. The southern of these two avenues leads from Government House to the residence of the commander-in-chief in India.

Below the eastern façade of the secretariats a forecourt, known as the Great Place, is laid out. This is partially enclosed by a beautiful Sanchi railing in red sandstone and is adorned with six water basins and fountains. In two chambers, one in each basement of the two secretariats, the chambers being entered from the Great Place, are now installed the inaugural stones laid by the King-Emporer, surmounted by the royal insignia cast in bronze.

Eastward again, below the Great Place, is a park known as the Central Vista, planted with lines of jaman-trees and having two water basins, one on either side of the central roadway, for the whole of its length. On either side of this Central Vista are arranged the houses of the members of Council. The Central Vista at its eastern end opens out into a park, hexagonal in shape, in which is to be

built the All-India War Memorial Arch. This central parkway was intended ultimately to terminate at a small lake, the waters of which would wash the base of the northern end of Indrapat.

A second principal avenue of the city intersects at right angles the Central Vista about midway in its length. In the four angles formed by this intersection were planned four large buildings, to accommodate, amongst other institutions, the Imperial Record Office, the Ethnological Museum, the Medical Research Institute, a Library and War Museum. At the northern end of this avenue is situated the business and commercial centre of the city. This consists of a circus, 1,600 ft. in diameter, around which are arranged 12 blocks of buildings, each three storeys high. At this circus the new post and telegraph office is to be located. Of the 12 roads which radiate from this centre, that due N. will give a state entrance to the new joint railway station. This same avenue, southward of the Central Vista, will sight on to the Anglican cathedral, around which are built the residences of the principal officers of Government.

The avenue radiating due N. from the focal point of the city on Raisina Hill sights on to the Roman Catholic cathedral, all around which are situated the houses of the Indian and European superintendents and clerks of the secretariats, the Lady Hardinge Medical College and Hospital for Women being slightly to the north-east.

A little towards the E., the next main avenue passes through the business centre already referred to, and sights in the distance on to the dome of the Jama Masjid in the old city. Immediately below the northern block of the secretariats is placed the building designed to accommodate the Council of State, the Legislative Assembly and the Chamber of Princes. A little farther eastward, the next avenue sights on to the proposed Delhi University.

Facing now due S., an important avenue leads to the club, with the racecourse beyond, a large recreation park being slightly to the W. and Saldar Jang's mausoleum slightly to the east. Turning again a little farther to the E., we overlook the Lodi Park, in which are situated the tombs of the Lodi dynasty.

The eastern side of the city will be largely occupied by the residences of ruling princes and chiefs and prominent Indian gentlemen.

At the Royal Academy in 1914 there were exhibited drawings by Sir Edwin Lutyens and Mr. Herbert Baker (the architects jointly responsible), which showed how it was proposed to treat the main architectural problems of the new capital. Government House and the two blocks of secretariats were planned as one group or capitol facing eastward, with the afforested southern ridge behind it to the west. A prolonged "battle of the styles" has been waged over the New Delhi, and if these designs give satisfaction to neither of the extreme and opposed schools, they clearly showed an endeavour to apply, with due regard for Indian sentiment, the spirit of the great traditions of architecture to the solution of structural problems conditioned upon Indian climate and requirements. The inspiration of these designs is manifestly Western, but they combine with it distinctive Indian features without doing violence to the principles of structural fitness and artistic unity.

Government Court has a length from W. to E. of about 1,100 ft. and a width between the two blocks of secretariats of about 400 feet. These buildings have been designed by Mr. Baker. The eastern end of each block is marked by deep loggias looking out over the Central Vista. In the centre of each block is a dome. In the case of the N. block this marks an entrance hall; in the S. block it surmounts a conference hall with a suite of reception-rooms. Each block contains four floors: on the main ground floor are the general offices of the departments; on the first floor are the offices of members of Council, secretaries and other officers; whilst the remaining floors are occupied by clerks' rooms and records. An essential feature of the design, and one which sets the character of the whole building, is the provision of loggias and recessed gateways or exedrae giving views through to the fountain courts situate in the interior of the blocks, and these take the place of the continuous verandahs that are so familiar a feature of Indian buildings. The architect relies for control of Indian climate and requirements on the use of thick external walls, together with window shutters as adopted so widely in southern Europe, and on the wide chajja characteristic of Oriental buildings. The Viceroy's Court is about 600 ft. in width and 1,300 ft. in length and it will be treated with grass, waterways and fountains and shady trees, and will form a dignified approach to Government House. Here will be erected the column, funds for which were provided by the Maharaja of Jaipur.

The great portico of Government House is raised some 20 ft. above the level of the Viceroy's Court and 35 ft. above the surrounding country. The house itself centres round the great Durbar Hall, a domed structure which dominates the scheme of the buildings surrounding it. Grouped round the Durbar Hall are the state rooms and the great stairways from the entrance courts on the N. and S. sides. Projecting from this central block are four wings: that on the S.W. contains the viceroy's private apartments; in the S.E. wing accommodation is provided for the A.D.C.'s; to the viceroy; guests are accommodated in the N.W. wing; whilst the N.E. wing contains the offices of the Viceroy's private and military secretaries. On the W. side of the house will be a raised garden, walled and terraced after the manner of the Moghals. This building, with the subsidiary buildings of the viceregal estate, has been designed by Sir Edwin Lutyens.

The building which will accommodate the Legislative Chambers is circular in plan and surrounded by a colonnade. The plan is divided into six sectors, utilized respectively by the Council Chambers and subsidiary accommodation for the Council of State, the Legislative Assembly and the Chamber of Princes, with three open courts separating these three chambers. A common library is situated in the centre of the building. The foundation stone for this building was laid on Feb. 12 1921 by the Duke of Connaught, and the building has been designed by Mr. Baker.

The All-India War Memorial is to be a monument in the form of a triumphal arch. It will be built in white stone upon a red sandstone base and will rise to a height of 162 feet. It will be surmounted by a flame, so that on occasions of commemoration a column of smoke by day and of flame by night will rise. The structure consists of a mass pierced through from E. to W. by the great arch, 37½ ft. high and 35 ft. wide, which spans the Processional Avenue. The piers thus formed are pierced by smaller arches which run through at right angles to the main arch. The freedom from intricate ornament and the simplicity of the design give the monument an appearance of dignity. Above the great cornice is inscribed the one word "INDIA," flanked by the dates "1914" and "1919." This monument was designed by Sir Edwin Lutyens, and the foundation stone was laid by the Duke of Connaught on Feb. 10 1921.

The estimate of cost for those works in the new capital which were being carried out by Government, according to the revised figures available in March 1921, was Rs. 12,91,80,000 (or at Rs. 15 to the ft. £8,612,000).

On Oct. 1 1912, by proclamation, there was constituted the Administrative Province of Delhi under a chief commissioner. This area was taken entirely from the old Delhi district of the Punjab. Delhi province had originally an area of 528 sq. m., to which was added later an area of 45 sq. m., to the E. of the Jumna river and taken from the United Provinces, to serve as a grazing ground for the cattle of the city. The total area of the province is now therefore 573 sq. m., comprising, on the basis of the census of 1911, a pop. of 412,821. (H. W. M.)

**DELISLE, LÉOPOLD VICTOR** (1826-1910), French bibliophile and historian (see 7.964), published in 1909 his edition of the *Rouveau Mortuaire du B. Vital, Abbé de Saizigni*, and also *Les Actes de Henri II.* (vol. ii appeared in 1916). He died at Chantilly July 22 1910.

See R. L. Poole, *Léopold Delisle* (1911); X. Delisle, *Lettres de Léopold Delisle* (1911-4).

**DELIUS, FREDERICK** (1863- ), English musical composer, born at Bradford, Yorks., Jan. 20 1863, was educated primarily at the International College, Isleworth, and was destined by his parents for a mercantile career. To Delius the prospect thus held out was unendurable, though, rather paradoxically, when he declined the business career proffered to him in Bradford, he set out for Florida, where he established himself as an orange planter. His spare time, however, was devoted to such musical study as he could obtain from such books as were in his diminutive library. In this sense he, like Elgar, was self-taught. But he quickly broke away from orange-groves and betook himself to Leipzig, where he underwent a more or less regular course of training at the hands of Jadassohn, though probably he learnt more of practical use from Grieg who at that time was resident in Leipzig studying the art of scoring for a modern orchestra. In or about 1900 Delius took up his abode at Grez-sur-Loing (S. et L.), near Fontainebleau, which subsequently was his principal domicile, though he travelled in many lands. He was in Norway in 1897 when his incidental music was produced to Gunnar Heiberg's *Folkeraadet*, and, by its satirical use of the National Anthem, set the town by the ears. Meanwhile compositions flowed from his ready brain. He gave a concert of some of them in London in 1899 when his *Légende for violin* (composed in 1892) was produced. In 1893 his fantasia-overture *Over the Hills and Far Away* was done by Dr. Haym at Elberfeld, and followed in 1897 by his pianoforte concerto in C minor. This fine work, however, was ultimately recast and produced in London at a promenade concert in 1907 by Theo. Szanto, a Hungarian pianist. But before then, in 1896, Delius's first opera, *Koanga*, was in the making. It was produced at Elberfeld in 1904. His second opera, *Romeo and Juliet in the Village*, was first performed at the Komische Oper in Berlin in 1907, and subsequently was given by Sir Thomas Beecham at Covent Garden in Feb. 1910 and, in a revised version, in 1919. A third opera, *Fennimore and Gerdo*, was staged at Frankfurt a/M soon after the Armistice.

In between the intervals of opera-composing, Delius was very busy producing purely orchestral works, or works for chorus and orchestra for the concert room. Thus *Life's Dance* dates from 1898; *Paris: the Song of a Great City from 1900; Appalachia* (1903); *Sea Drift* (1904); *A Mass of Life* (after Nietzsche, 1905); *Brigg Fair* (1908); *In a Summer Garden* (1908); *Requiem* (1909); *a Poem of Life and Love and Eventyr* (1910). Besides all this Delius composed a violin concerto and a double concerto for violin and violoncello, a violin and a 'cello sonata, and a string quartet, many songs and several a capella choruses.

**DEMOBILIZATION AND RESETTLEMENT.**—No labour problem of greater difficulty has ever had to be faced than that of national demobilization, whether military or civilian, after the World War, because of the dimensions to which the calling-up of national man-power had attained. An account of post-war demobilization and resettlement in industry, in the United Kingdom, from the civilian point of view, divides itself into three clearly marked periods: (A.), the preparations during the pre-Armistice period; (B.), the action taken immediately after the Armistice; and (C.), during the first two years of resettlement. (For the Army demobilization, see ARMY.)

#### (A.) PRE-ARMISTICE PERIOD

There were two lines upon which British Government preparations proceeded during the pre-Armistice period in respect of civilian workers.—

(a) The bringing of workers demobilized from munitions work and war work as quickly and as conveniently as possible to peacetime work.

(b) The rapid turnover from war to peace so that employment might be available for the largest number at the earliest moment. For the provision for unemployment, see the article UNEMPLOYMENT.

(a) *The Bringing of Workers Demobilised from Munitions Work and War Work.*—In making plans for the demobilization of civilians account had to be taken of the possibly simultaneous demobilization of the armed forces. The ideal would have been to have fitted civilian workers into their places before the forces had been demobilized so that there should be no confusion as between the two masses of demobilized persons. In point of fact it was recognized from the outset that it would be impossible to complete one process before the other began, first because industry could not in many places be started up again without the return of numbers of pivotal men with the forces, and secondly because large numbers of men with the forces had either a statutory right or a promise to return to a particular employment. It was accordingly necessary to frame a scheme for civilian workers which could work conveniently side by side with the scheme devised for the demobilization of the forces. The demobilization of the forces took into account throughout the necessity of approaching the matter, subject to paramount strategic considerations, upon an industrial basis. From the first report on military demobilization, signed in Dec. 1914 by Sir H. Llewellyn Smith and Sir R. H. Brade (as secretaries of the Board of Trade and War Office respectively), right through to the second interim report of the Ministry of Reconstruction Committee on the demobilization of the army, in Oct. 1917, this aspect of the question was steadily faced. It was recognized that demobilization must be so arranged as to render the transition from war to peace as easy as possible, which meant arranging it so far as possible to fall in with the immediate needs of the post-war industrial situation.

The principles upon which the recommendations as to military demobilization proceeded must be briefly explained, in order that the way in which these were related to those laid down for civilian workers may be appreciated.

The objects aimed at were to reduce unemployment to the lowest possible point, but at the same time to make adequate provision for such unemployment as was inevitable. In order to meet the first point it was recommended that demobilization should, subject to military exigencies, be carried out according to the requirements of trade and industry, which meant disbanding first men for whom employment was ascertained to be available or men in relative specified in a priority list drawn up with reference to the trade urgency of the industrial requirements of the country. To meet the second object the committee recommended the provision of a free unemployment insurance policy to be given on demobilization.

The object of the army scheme, which was to get men to the place where they could be employed as rapidly as possible, formed also the first part of the civilian demobilization scheme. The questions of civilian demobilization were considered from this point of view partly by the Civil War Workers' Committee appointed by the Ministry of Reconstruction, which issued five reports during 1918, partly by the Ministry of Labour, and partly by the Labour Resettlement Committee set up by the Ministry of Labour. The recommendations of these various bodies are arranged not in the order in which they were actually made, but in relation to the order of the events with which they deal.

The first point to be considered was the order of discharge from munitions works, just as the first point to be considered in army demobilization was the order in which men should be released from the colours. On this it was recommended by the Ministry of Labour—and the recommendation was accepted by the Cabinet—that the order of discharge should be as follows:—

(a) That adequate notice of discharge should be given to each individual worker.

(b) That adequate notice of the discharge ought to be given to the local employment exchange so that the exchange might be able to find employment for the worker.

(c) That the order of discharge should be: first, workers not dependent on industrial employment for a livelihood; second, workers brought from a distance; third, workers who could be readily absorbed in their previous occupation or in one of the staple industries of the district.

It was regarded as of paramount importance that the previous industrial experience of the workpeople who were to be dismissed, and the demand for workpeople of their experience elsewhere, should be adequately considered by factory managements in consultation with the officials of the Ministry of Labour before the selection of the individuals to be discharged was made.

In order that persons discharged should be able to travel to their homes at the earliest possible moment, or to their new places of employment, it was recommended in the fifth report of the Civil War Workers' Committee that free railway passes should be issued to those persons who had changed their place of residence for the purpose of taking up work on munitions or on naval or army contracts, and who might be displaced from such employment owing to the cessation of hostilities. In such cases the worker should have the option of having his or her fare paid either to the usual place of residence, or to some other place at which work is available.

After the cessation of the order of discharge there was the question to be considered of the actual machinery for bringing workers into touch with possible employers. On this the following recommendations were made by a committee of the Civil War Workers' Committee: (a) Steps should be taken by the Government, through the machinery of the employment exchanges, to assist war workers to return to their former employment. In addition, joint industrial councils and similar joint bodies for individual industries should be taken into consultation. (b) Steps should be taken as soon as there was a reasonable prospect of peace to ascertain where war workers would be required. (c) Workers should be encouraged to register their requirements. Proposals were also made as to limiting the flow of juvenile entrants into the rank of wage earners by means of prolonging the school age, and further schemes were proposed for watching the placing of young persons in industry.

Action on these recommendations was possible during the pre-Armistice period only in so far as it would not disturb the munitions output by giving workers the impression that peace was in sight before the facts justified this belief. It was therefore not possible until immediately before the Armistice to take full advantage of the proposals for bringing employers and workpeople into touch.

It was universally felt that the machinery for demobilization must be found in the employment exchange system. It was, however, suggested that the employment exchange machine might break down under the heavy strain imposed upon it unless it were supplemented. The Minister of Labour had appreciated this aspect of the problem and in 1917 had appointed a series of local employment committees to advise and assist exchanges. These committees (see UNEMPLOYMENT) consisted of equal numbers of employers and employed presided over by a chairman nominated by the Minister of Labour. A committee was attached to each principal exchange area and its duties were generally to advise upon the work of the exchange and particularly to help in the task of the demobilization of civilian workers. The various schemes prepared by the Ministry of Labour were circulated to these committees, so that when the period of actual demobilization came they were fully prepared to handle them. In addition a central committee known as the Labour Resettlement Committee was set up by the Minister of Labour to advise the Ministry nationally, just as the exchanges were advised locally.

In the next place the actual machinery necessary to effect the rapid demobilization and transfer of workers was elaborated in detail by a Departmental Committee set up by the Minister of Labour. This committee divided its report into four parts:— (i) registration of workpeople under notice of discharge; (ii) distribution of completed forms of registration to exchanges or other local offices; (iii) negotiations with the previous or other employers of the workpeople in order that there may be no avoidable interval of unemployment

after discharge from war employment; (iv) placing of workpeople in employment after their discharge.

Under these four heads the committee worked out in detail the registration forms and cards which would be necessary for an effective indexing of the workers. They worked out the system of interchange between the exchange at which a worker was discharged and the exchange at which he was to be re-employed. They suggested a method by which, upon interchange of the forms, the exchange in the neighbourhood where the man sought employment put itself into touch with the employer, and notified the result of this communication to the exchange of discharge. Finally, they made proposals by which a worker previously engaged upon war work, seeking employment, could be traced so that he could be fitted into the general scheme.

Apart from these preparations for action to be taken upon the cessation of hostilities, certain action was being taken in respect of men returning, disabled or unfit, from the colours. This work was undertaken as a result of the recommendation of the Resettlement of Officers Committee under the chairmanship of Sir Reginald Brade, which recommended that "an Appointments Board for officers and men of like standing should be established under the control of the Ministry of Labour to operate with the existing University Appointments Boards or other approved bodies." There had been two departments dealing from different points of view with this problem. In 1915 a special department of the Ministry of Labour had been set up, known as the Professional and Business Register, whose work consisted in finding appointments for persons of the classes covered by its title. During the earlier years of the war its duties principally consisted in finding war employment for persons of the professional classes who were either unable to pursue their pre-war occupation owing to war conditions or who wished to be used upon national service. In addition there was established early in July at the Ministry of Munitions an organization known as the Officers' University and Technical Training Classes. These provided the means by which unfit officers and professional and business men in the ranks could attend universities, technical institutions and other centres of instruction during their period of convalescence. Candidates so trained, if still unfit for active service, were utilized to meet the immediate demands of Government departments.

Following upon the report of the Brade Committee it was considered convenient to combine these two departments under one control, and the Appointments Department of the Ministry of Labour was established in April 1918. Previous to the cessation of hostilities the department performed two functions: (i) the training of the convalescent serving officer, and (ii) the placing in employment of officers, whether trained or untrained, as well as of professional men. The training of the convalescent serving officer was in operation for more than 12 months previous to the Armistice. Some 4,000 cases passed through the training scheme. The officers received training for practically every professional and higher commercial appointment. At this stage, while demands still far outran supply, no considerable difficulties in placing the trained men arose.

These proposals affected officers. The placing of workpeople remained with the exchanges, but the question of the training of disabled members of the forces was also receiving attention. Joint committees were formed by the Ministry of Labour for dealing with this problem for a number of trades. These committees were generally on a national basis and devoted themselves to laying down conditions upon which trainees could be admitted into industry. Both as regards officers and men these two schemes, which formed the foundation of the large schemes, were operated after the Armistice by the Appointments and Training Departments respectively.

(b) *The Rapid Turnover from War to Peace.*—The proposals on this head may be considered under two aspects:—

(a) Proposals as to the way in which the Government should treat its contracts with a view to reducing the dislocation consequent on the change from war to peace to the lowest possible point.

(b) Proposals for development of industries in peace with special reference to the lessons learned during the war.

So far as munitions contracts were concerned there had to be considered (i) termination of contracts for the supply of munitions, (ii) disposal of stores, stock and material, machinery, etc., in the possession of the Government, and (iii) the arrangements for the disposal or post-war use of national factories with their plant and equipment.

With regard to contracts it was plain that to continue manufacture of munitions for a moment longer than the military situation required was in the highest degree uneconomic. At the same time regard had to be had to the fact that a sudden cessation of all contracts would lead to unemployment on a hitherto unexampled scale, and would, moreover, with regard to such munitions as guns and tanks, lead to the abandonment of manufacture at an advanced stage in the process. It was recommended by the Ministry of Munitions, and accepted by the Cabinet, that the manufacture of munitions should be terminated at the earliest possible moment, subject to discretion both as regards creating excessive unemployment and with regard to



the waste that would be engendered by the sudden cessation of the manufacture of expensive articles nearly completed.

With regard to the disposal of stores, the Surplus Stores Department of the Ministry of Munitions had been proceeding for some time with the day-to-day disposal of obsolete munitions, scrap, surplus machinery and other movable property no longer required by the Ministry. Owing to the enormous field covered by the Ministry this was a considerable operation, but one almost negligible as compared with the gigantic business which would have to be undertaken in respect of the accumulation of war stores on the cessation of hostilities. It was pointed out that large quantities of materials had been delivered to contractors to enable them to carry out their contracts, and plant and machinery had in many cases been installed in the works of manufacturers on terms which formed part of the contracts themselves. The Ministry of Munitions were made responsible for the disposal of these stores, and it was at that time considered not improbable that on the completion of this work the Ministry of Munitions would be converted into a permanent Ministry of Supply combining in itself the supply departments of the Admiralty, War Office, Air Force and even of the Stationery Office, and Office of Works.

The question of the post-war use of national factories was discussed as one of general policy. In labour quarters the view was strongly held that these factories should be put into commission immediately upon the cessation of hostilities to provide employment during the transition period, and thereafter should be operated by the Government in competition with private enterprise. These proposals were rejected. In the first place it was pointed out that for the immediate period of transition the factories would be useless. To convert a shell-producing factory into a factory for commercial purposes would take anywhere from six months to a year, and at the end of the year it was hoped that the worst period of dislocation would be over. Apart from this, on general grounds, it was felt that the Government by entering into competition with the private trader would to a great extent decrease rather than increase employment. The Minister of Munitions was therefore authorized to make arrangements for the disposal of national factories.

In fact, all the national factories, with the exception of a small number retained in connexion with the work of the Training Department to the Ministry of Labour, were disposed of. In addition to the cessation of contracts the Government's obligation in respect of placing further contracts in regard to peace requirements was also considered. It had long been maintained by labour opinion that the placing of Government contracts with special regard to possible unemployment would to a certain extent help to reduce unemployment. When, however, the volume of peace-time contracts is compared with the general volume of trade, it becomes apparent that the more careful placing of such contracts can do little to mitigate a situation in which unemployment is really serious. While this is so, in so far as Government contracts and contracts placed by public bodies can alleviate the situation, it was recommended that Government departments and public or semi-public bodies should be urged to place contracts for their peace requirements at the earliest possible moment. In point of fact this recommendation failed of its effect because public bodies (like private employers), being utterly unable to foresee the course of prices during the transition period, were not disposed to run the grave financial risks involved.

Proposals were further made with a view to the development of industry immediately upon the cessation of hostilities. These proposals took two forms. (a) proposals for obtaining new markets and the materials necessary for post-war manufacture, and (b) the actual development of the various industries.

Under the first head it was contemplated that the reconstruction of the devastated areas of Belgium and France would necessarily bring large orders to the British manufacturers. It was accordingly proposed that an International Commission should be appointed to investigate the question of reconstruction work in the devastated areas of Belgium and northern France and to prepare schedules of contracts. Proposals were further made with a view to stimulating those industries, such as dyes and glass, which had during the war taken over processes previously carried on by the Germans.

With regard to materials, the early history of munitions supply had indicated that in the handling of raw materials lay the key to the control of industry. Metal and ore during the war had been controlled by the Priority Department of the Ministry of Munitions, wool and textiles (except cotton) by the War Office, and cotton by the Board of Trade. Two steps were taken to apply similar principles to the period of reconstruction. In the first place a Priorities Committee of Cabinet Ministers was set up as the ultimate authority for the allocation of raw materials. In the second a standing council was established consisting of leading representatives of commerce, industry, labour and the departments concerned to advise the Cabinet Committee. Ancillary to these bodies control departments for building were established under the general direction of the Ministry of Reconstruction. Under these general authorities special committees were set up for various trades, and under the nature and amount of supplies of materials and foodstuffs, which, in their opinion, would be required by the United Kingdom during the period which might elapse between the termination of the World War and the restoration of a normal condition of trade.

With regard to the development of industry, the future of engineering, agriculture and electric power were held to be the burning problems of the moment. So far as the employment of women was concerned attention was directed to their rights as competitors with men and the means by which they could be encouraged to revert to domestic service.

**Engineering.**—The first engineering committee was appointed by the Board of Trade under the chairmanship of Sir Clarendon Hyde and made certain recommendations dealing with essential industries, the amalgamation and joint working of existing firms, apprentices, technical education, trade combination, trade marks and patents. In particular it recommended that "every effort should be made to develop and encourage the medium and light engineering trades, whether already existing in this country or not, thereby making use of the workshop motive power and equipment installed for war purposes, and finding suitable employment for the large body of semi-skilled and female labour recently created."

This last recommendation was accepted by the Government, and the Minister of Reconstruction appointed a further committee, known as the Engineering Trades (New Industries) Committee, under the chairmanship of the Hon. H. D. McLaren—

To compile a list of the articles suitable for manufacture by those with engineering trade experience or plant, which were either not made in the United Kingdom before the war, but were imported, or were made in the United Kingdom in small or insufficient quantities and for which there is likely to be a considerable demand after the war, classified as to whether they are capable of being made by (1) women, (2) men and women, (3) skilled men, and setting out the industries to which such new manufactures would most suitably be attached; and to make recommendations—

"(a) On the establishment and development of such industries by the transfer of labour, machines and otherwise;

"(b) As to how such a transfer could be made, and what organization would be requisite for the purpose, with due regard to securing the co-operation of labour."

This committee appointed sub-committees to deal with the various branches of engineering.

**Agriculture.**—So far as agriculture was concerned, in 1915 the Prime Minister appointed a committee under the chairmanship of Lord Selborne. Their first report resulted in the setting up of the Agricultural Wages Boards which have regulated the wages of agricultural workers. The final report, presented in Jan. 1918, dealt with the problems of small holdings, land reclamation and drainage, credit facilities for land settlers, village reconstruction, and rural transport.

**Electric Power.** Two committees were set up to deal with electric power in 1917. The first, appointed by the Board of Trade, under the chairmanship of Sir Archibald Williamson reported: (a) that a highly important element in reducing manufacturing costs will be the general extension of the use of electric power supplied at the lowest possible price; (b) that the present system under which a supply of electricity is provided in a large number of small areas by separate authorities is incompatible with anything that can now be accepted as a technically sound system; (c) that a comprehensive system for the generation of electricity, and, where necessary, reorganizing its supply, should be established as soon as possible.

The problem was further considered by the committee of chairmen on electric power supply.<sup>1</sup> They reported (a) that the development of electricity should take place on a national scale and under the control of the State; (b) that an Electricity Board should be set up to advise upon and control the carrying out of the national scheme, assisted by an operating executive; and (c) that the first duty of the Board would be to plan out a comprehensive scheme for the whole country, and then by degrees to secure the development of electrical power over the whole of the United Kingdom by such methods as they might find suitable to the requirements of different areas.

In this way the committee of chairmen reduced the general principles enunciated by Sir Archibald Williamson's committee to practical proposals, though proposals still on a universal scale. The electricity commissioners under the Ministry of Transport were the tangible result of these recommendations.

#### (B.) IMMEDIATE POST-ARMISTICE PERIOD

On Nov. 11 1918 the Ministry of Munitions issued to contractors, sub-contractors and workpeople engaged on work for the Department, a notice indicating the line of action to be followed. The instruction proceeded on the following lines:—

1. There should, as far as possible, be no immediate general discharge of munition workers.

2. All workers, however, who desire to withdraw from industry or to leave for any reason, and all workers who can be absorbed elsewhere, should at once be released. Production on contracts for guns

<sup>1</sup> Engineering Trades (New Industries) Committee Report (Cd. 9,226).

<sup>2</sup> Agricultural Policy Sub-Committee Report (Cd. 9,079).

<sup>3</sup> Cd. 9,062.

<sup>4</sup> Cd. 93.

and gun munition, machine-guns, small arms and small-arms munition, trench mortars, bombs and stores, pyrotechnic stores, aerial bombs, or accessories of the above stores, aircraft and air engines, and the manufacture of explosives, should be reduced in the following ways: (a) all overtime should be immediately abolished; (b) systems of payment by results may be temporarily suspended; (c) where reduced hours are worked upon a time-work basis, the number of hours worked must not be less than one-half of the hours in the present normal working week. If the earnings of workpeople fall below certain figures they will be made up to them by the State.

3. The adoption of half-time may cause discharges, but these should be spread out for as long a period as possible.

4. Free railway facilities will be provided for workpeople from the place of employment to their homes or to places where they have new employment.

At the same time, the first announcement was made of the institution of a temporary non-contributory scheme for unemployment which would remain in force pending the introduction of a general contributory scheme, the main provisions of which were that unemployed men were to receive 24s. per week and women 20s. (later increased to 30s. and 25s.), with additional allowances for dependants. Almost immediately afterwards instructions were issued in respect of war munition volunteers, war work volunteers, national service and war agriculture volunteers indicating that the schemes would be terminated at Dec. 14 1918. A notice was issued at the end of Nov. dealing with soldiers released from the colours, and army reserve munition workers.

These instructions indicated the methods by which the employment of these men under war conditions would be terminated. They followed to a large extent the lines of the recommendations prepared by the committees mentioned above; but it was felt by the Government that it was necessary to constitute a special department for dealing with problems of civil demobilization. Accordingly, at the end of Nov. a Controller-General of Civil Demobilization and Resettlement was appointed and his department was attached to the Ministry of Labour. This department was made responsible for:—

(a) the actual machinery of the return both of the men from the forces and civilian workers to their previous occupations through the employment exchanges;

(b) attempting to remove from the labour point of view obstacles to the restarting of industry; and

(c) the administration of the Appointments Department which dealt, on a rapidly increasing scale as demobilization proceeded, with the training and placing of ex-officers and men of similar educational qualifications. To these functions were added later the responsibility for the Civil Liabilities Resettlement Scheme.

The first few months were a time of great difficulty and strain. On the one hand the machinery devised for demobilization of the forces was found to be too slow to meet the situation and a new scheme was introduced which enormously expedited the procedure. This led to a position when very large numbers of both ex-civilian workers and ex-service men were out of work at the same time. Immediately, therefore, protests were made against the rapid closing down of factories engaged upon war work. Deputations were constantly received both by the Minister of Labour and the Minister of Munitions protesting against the closing of factories engaged upon war work, and during the end of 1918 and the early months of 1919 it was found necessary to keep certain factories engaged on munitions at work even though their products were not likely to be required. Every effort was made by the newly created Civil Demobilization and Resettlement Department to make the transition from war to peace work as easy and as rapid as possible. For this purpose at the end of 1918 it was decided to set up for each of the areas covered by the Ministry of Labour Employment Exchanges a divisional council, elected from members of the local employment committees to which reference has already been made. The business of these councils, which operated till the later months of 1919, was to co-ordinate the work of the local employment committee and particularly to help in the transition from war to peace. In order to assist the councils in their work a number of officers known as Resettlement Officers were appointed by the Minister, whose business was to travel round the country and investigate the causes which impeded the

turnover from war to peace. Such conditions as a temporary shortage of materials, shortage of rolling stock, inability to recover premises required for business purposes commandeered by the Government, housing difficulties, and many other matters of this type were investigated and dealt with by these officers under the directions of the Minister and of the divisional councils. At the end of the year, the Government set up a minister in general charge of reconstruction problems, with a council designed to review the position generally and give instructions to the various departments concerned in the work. This council terminated its functions upon the formation of the Lloyd George Government at the beginning of 1919.

(C.) THE FIRST TWO YEARS OF RESETTLEMENT

The success of the preparations which had been made, and of the method in which the machinery was worked, is indicated by the figures of re-absorption of men demobilized. For six months after the Armistice there was a steady increase in the number of ex-service men unemployed, and at the beginning of May 1919, when about 3,300,000 men had been discharged, over 400,000 were recorded as drawing out-of-work donation. From that date, although the numbers discharged continued to rise, there was an almost uninterrupted fall in the number unemployed, until, at the end of July 1920, when demobilization was practically complete and over 5,000,000 men had been discharged, less than 150,000, or only 3% were registered as unemployed.

These figures relate only to ex-service men, and in order to discover how far the ex-civilian workers had been reabsorbed, it is necessary to look at the unemployment figures for the same period. After the Armistice the number of civilian workpeople unemployed rose continuously until the beginning of March 1919, when nearly 800,000 were recorded as receiving out-of-work donation. After that date, however, there was a rapid improvement, and by the end of Sept. the number had fallen to about 100,000. Owing to changes in administration and in some cases to the exhaustion of benefit, the figures, no doubt, overstate the extent of the improvement, but, even when due allowance is made for these factors, it is clear that there was a remarkable recovery after March 1919. The evidence so furnished is confirmed by the statistics of unemployment among the members of certain trade unions which make regular returns to the Ministry of Labour. In these unions (mainly composed of skilled workmen) the proportion unemployed, which was 0.4% at the end of Oct. 1918, rose month by month after the Armistice until it reached 2.0% at the end of March 1919. From that date, however, it fell, and at the end of Sept. 1919 it was only 1.6%. There was a further rise in the winter of 1919-20, due to the strikes in the railway service and in the iron foundries; but the percentage fell again in the spring of 1920, and from March to June of that year, when demobilization was almost completed, it varied between 0.9 and 1.2%, much below the figure for any month in 1913, which was itself a year of good employment.

The consideration of these figures indicates that the turnover from war to peace had been effected with surprising speed and with remarkable lack of trouble. But while in the first 18 months after the Armistice trade would have rapidly recovered, provision was urgently required for certain large classes of ex-service men which may be grouped as follows:—

(a) the disabled who, although in receipt of pensions, required training to enable them to enter upon some occupation;

(b) youths whose apprenticeships had been interrupted;

(c) women thrown out of work by the turnover from war to peace;

(d) the ex-officer who, as a result of the war, was either unable or, for adequate causes, unwilling to resume his old occupation; and

(e) the large number of men who had had some small business or undertaking which had been seriously affected by the war.

So far as the first class was concerned two steps were taken—the first to place men in immediate employment, the second to train them for employment later.

Placing of Disabled Men.—During 1917 a scheme had been proposed by Mr. Rothbard, of Manchester, for absorbing a proportion of disabled men in each industry. This scheme was fully canvassed during the later years of the World War, and finally, in Aug. 1919, was adopted by the Government. In that month the King's National

Roll for disabled men was inaugurated by Royal Proclamation, and the scheme itself was actually launched on Sept. 15. The basis of the scheme was to ask each industry to take disabled men into its ranks to a proportion of 5% of the total employees. Individual employers who agreed to come into the scheme were given a certificate to that effect, and were entitled to use a special seal saying that they were inscribed upon the National Roll. Industries, of course, vary considerably in their power to absorb disabled men, and the 5% was not rigidly enforced, but they were invited to take as large a percentage as the nature of the work permitted. The scheme worked with considerable success. At Feb. 19, 1921 the number of employers on the roll was 24,278. The total staffs covered by them was 4,167,173; the number of disabled ex-service men employed was 270,552.

The Roll was headed by the King and Queen Alexandra. H. M. Treasury were entered upon the Roll in respect of Government departments and Government industrial establishments, and the Roll included the staff of the Houses of Lords and Commons and of the Law Courts. Special efforts were made to include local authorities upon the Roll, and at the date mentioned above there were 751 upon the Roll in England and Wales, and 68 upon the Roll in Scotland. In addition arrangements were made by which preference was given in allocating Government contracts to employers whose names were upon the Roll. It may be noted in this connexion that when the scheme was launched in Sept. 1919 the number of disabled ex-service men who had registered themselves as unemployed was 41,616. There is no doubt that in addition to the men registered there was a considerable number, perhaps as many as 20,000, who had not reported themselves—a fact which is proved by additional registrations which followed upon the inauguration of the scheme. As a result of the scheme the figure fell to 14,849 in Sept. 1920. Of these a considerable number were in Ireland, where the National Roll, for various reasons, could not operate.

Training dealt with three main classes: The disabled ex-service man who could not, owing to his disability, return to his pre-war occupation; the man whose apprenticeship had been interrupted by war service and could not be renewed without assistance from the State; and the woman who, by entering munitions work at an early age, had failed to acquire the woman's trade. In addition to these classes there was the fit ex-service man whose call to the army or navy at an early age had prevented him from acquiring a skilled trade. For industrial reasons it was soon found that little could be done unless he had commenced an apprenticeship before the war.

On Aug. 1 1919, when the industrial training of disabled ex-service men was taken over by the Ministry of Labour from the Ministry of Pensions, about 10,000 men had already been trained, about 12,000 were under training, and some 75,000 more were estimated to be awaiting training. In dealing with this problem the policy of the Training Department was to associate the administration of industrial training with local education authorities, to retain and increase the co-operation already established in training matters with the trades and industries concerned, and to repair the shortage of training facilities by the establishment of Government instructional factories. The organization set up was based on the division of the country into 17 administrative areas, each under a divisional director.

The co-operation of the employers and workpeople of the industries and trades in which men were being trained had already been secured after protracted negotiations with the leading British industries, which were conducted in 1916 and 1917 by the late Mr. St. George Heath of the Ministry of Labour. These negotiations resulted in a series of agreements to which representatives of employers' organizations, trade unions and the State were contracting parties, providing for the precise length of the training courses, the regulation by each trade of the number of men admitted to training in it, and the proportion of the men's pay respectively contributable by the employer and the State. The training schemes were drawn up by the National Trade Advisory Committees, composed of equal numbers of representatives of employers and workpeople, and their supervision was carried out by Local Technical Advisory Committees, similarly constituted, without whose consent no man was to be placed into training.

The policy of concentrating training in the Government instructional factory, based on the closest possible imitation of the management, discipline, machinery and productive work of the ordinary factory, but differing from the latter in that its primary function is the output of trained men instead of finished goods, was the outcome of the great and growing demand during the war for semi-skilled workers, capable of setting free the skilled man for more complicated operations. The impossibility of obtaining a rapid supply of such workers through the ordinary workshop with its too intent upon production to occupy itself with the scientific upgrading of unskilled labour, or through the existing machinery of the technical schools, which were out of touch with the requirements of modern large-scale manufacture, compelled the Government to set up institutions of its own. In these was evolved a system of intensive training capable of teaching in two or three months, to a woman hitherto accustomed only to house work, one or two of the simple operations involved in specialized repetition work and of turning her, for example, into a competent capstan hand. The considerations which led to the adoption of this system for the purpose of dilution applied even more strongly to the case of the disabled man.

Up to Jan. 1921 some 50,000 men had been trained or were in training under the Ministry of Labour in addition to the 10,000 already trained when they took over from the Ministry of Pensions. Fifty Government instructional factories had been set up with accommodation for 20,000 men, providing training in most skilled trades in the country and engaged on productive work ranging from the building of houses to the repairing of watches and clocks.

The chief trades in which training was given were mechanical and electrical engineering, building in all its branches, furniture-making and wood-working, boot- and shoe-making and repairing (hand and machine), tailoring (wholesale and retail), watch- and clock-making and repairing, brush-making, basket-making, motor mechanics and commercial work, besides a great number of smaller trades, or trades, such as textiles and pottery, in which the amount of training given has been more limited. A considerable number of men were trained entirely in employers' workshops, but in the majority of cases a preliminary period in an institution, either a technical school or preferably an instructional factory, was given before placing a man for the completion of his training with an employer. The experience acquired during the war, in connexion with semi-skilled workers, that instruction controlled and directed on scientific principles results in a surprisingly high rate of progress on the part of the learner, was amply confirmed when applied to training for skilled occupations.

*Interrupted Apprenticeships.*—Prior to the Armistice a special committee, appointed by the Ministry of Reconstruction, considered this problem, and, in consultation with the Labour and Resettlement Committee, prepared a scheme to enable those involved to complete their apprenticeship. It was recognized that each industry had its own problems and that no uniform scheme could be adopted. The Committee, therefore, contented themselves with laying down certain general principles which should be observed if State assistance was to be obtained. It was left to each industry, through a organization representative of employers and operatives, to prepare a detailed scheme adapted to the needs of the industry concerned and embodying these general principles, which may be summarized as follows:—

(i) Men in the last year of their apprenticeship on enlistment should be regarded as journeymen.

(ii) The unexpired period of apprenticeship should be reduced by not less than one-third of the time lost by service in H. M. forces.

(iii) The time, if any, during which a man worked at his trade while in H. M. forces should be counted as part of the original apprenticeship.

(iv) After reaching the age when his original apprenticeship would have terminated, or the age of 21, whichever was the earlier, the man should be paid not less than three-quarters of the journeyman's rate for the first half of the resumed apprenticeship and not less than five-sixths for the remainder. Towards such wages the State would pay a grant equal to one-third of the journeyman's rate.

(v) Provision should be made in the scheme for allowing the training in the employer's establishment to be supplemented by training in a technical institute, the State agreeing to pay fees and a maintenance allowance.

(vi) An agreement should be entered into by employer and apprentice under which the employer undertook to train the apprentice as a skilled workman, and the apprentice to complete his training with the employer.

Forty distinct industries, covering about 800 different trades, prepared schemes in accordance with the principles laid down above. These schemes varied in many details, especially as regards the wages payable and the rate of deduction to be made from the unexpired period of apprenticeship in respect of the time served in H. M. forces.

An additional scheme was prepared by the Ministry of Labour to cover unorganized trades and trades where the small number of apprentices did not justify a special scheme.

The number of apprentices brought under the scheme was, at the end of Jan. 1921, 43,500. These figures do not indicate the total number of persons who, whether directly or indirectly, had benefited as a result of the scheme. A large number of important firms, including the majority of the railway companies, took back their ex-service apprentices under conditions as good as, or better than, those laid down in the scheme, but preferred not to ask for State assistance. Government departments, such as the Admiralty, the Ministry of Munitions and the Post Office, adopted a similar course. Persons in their last year of apprenticeship on enlistment were treated as journeymen but did not receive State assistance.

It has been estimated that the number of persons who in this way indirectly benefited under the scheme was at least as large as the number of those who were formally brought within its provisions.

On Jan. 1 1921 the number of apprentices who had applied and were eligible, but for whom employers had not been found willing to enable them to complete their apprenticeship, was 300. It will be seen, therefore, that practically the whole of those desiring to complete their apprenticeship were enabled to do so.

One of the conditions attached to payment of State assistance was an undertaking on the part of the employer that he would give to the apprentice the training necessary to make of him a skilled workman. It became, therefore, the duty of the Ministry of Labour to take steps to insure that this undertaking was carried out. Employers

might otherwise draw State assistance and exploit the labour of the apprentices by keeping them on "repetition" work. A small staff of specially qualified officers was accordingly appointed to visit the firms having apprentices under the scheme, and satisfy themselves that the training given was satisfactory.

The training given to these apprentices was modelled on the training given to boys. Where such was the case it was not possible to make exception to what was in fact the methods customary to industry. But in investigating the training of the ex-service men, the officers were, in effect, making a survey of the methods of training customary in the skilled trades in the case of boy apprentices. No such survey had ever been attempted before.

As stated earlier, each scheme for an industry was prepared by some organization representative of employers and operatives in that industry. Much thought was given by the industry to the preparation of these schemes, and the methods and facilities for training, whether in the workshop or technical institute, were fully discussed. A scheme when finally adopted represented, therefore, a considered agreement within the industry. In connexion with the administration of the various schemes, many difficult questions of interpretation arose. The Ministry of Labour made no attempt to give an interpretation, but referred the question to the trade organization who had prepared the scheme, and accepted their interpretation; acting on the assumption that the only body fitted to give a decision was the organization responsible for the scheme. Where disputes arose between an individual employer and apprentice, it was provided in the agreement between the two that such dispute should be referred to the Trade Panel of the Local Employment Committee and that the decision of the panel should be final.

It will be seen, therefore, that the policy underlying the scheme was one of administration under the advice and direction of the various industries. This policy was adopted after careful consideration. It was felt that, in view of the widespread dislike of Government interference, any attempt to impose a scheme on industry was bound to fail, and that success could be looked for only if the cooperation of industry was sought and secured. This policy has been justified by its results. The Ministry of Labour, throughout, was able to count on receiving the fullest assistance, both from employers' associations and trade unions.

**Women's Training.**—The first women's training course was opened at the end of May 1919. This was a course of training for domestic service, and 16 young women passed through the 13 weeks' course and obtained good situations at its close. Altogether 84 centres for training in domestic service were established, and just over 2,000 women trained. The experiment proved successful and encouraging. The courses were held in widely differing conditions and localities; but under the guidance of the teachers the interest of the women was aroused and the majority went straight into service from the schools. These classes were held in various parts of London and the suburbs and in 48 towns throughout Great Britain.

Apart from domestic service, some 7,000 women were trained for industry. The department's training was from the first restricted by the terms of the Treasury grant "to normal women's industries which were women's trades or processes before the war," and to these, notwithstanding much pressure from women's organizations, the women's training branch rigorously confined its activities. Three other conditions limited the sphere of its industrial training, viz. a reasonable prospect of absorption in the industry after training, good working conditions, coupled with fair wages, in the trade, and the consent of the trade unions and the employers concerned to training being given. Exhaustive enquiry and constant watchfulness were necessary in these connexions.

The greatest demand for training, combined with the best prospect of absorption and most favourable conditions, was found in the two chief women's trades—dressmaking and tailoring; and 77 courses were provided, affording accommodation for 3,362 women.

The majority of these training courses came to an end on June 30 1920, though a limited number were continued for varying periods in order that the standard course might in each case be completed, viz. six months for an industrial and three months for a domestic course. From July onwards but few new schemes (and those solely of a domestic type) were started, but by this time the trade slump had begun, and it was useless to train women for industries in which the chance of employment was of the slenderest.

The training referred to above is that of women who were thrown out of employment by the termination of the war. The Women's Training Branch, however, was entrusted with the training of two other classes of women directly affected by the war, viz. soldiers' widows and disabled nurses. The powers of the State to give such training to these women as would enable them to supplement their pensions by employment were first vested in the Ministry of Pensions by Royal Warrant, but were transferred to the Ministry of Labour by Order in Council in the autumn of 1919.

Over 4,000 applications from widows were dealt with, and training found for over 1,200 of those who applied. During the training, which was in all cases free, an allowance was made to the widow in addition to her pension to enable her to meet any extra expense to which she might be put. A large number of widows were trained as practising midwives. Having a home and a pension they were able, as few women were, to accept the precarious livelihood which

this calling offers in a rural district. As all had to pass the examination of the Central Midwives' Board, women of good general education only were selected for this particular branch. Another large group of the widows in training were those learning tailoring and dressmaking, home dressmaking being especially popular, possibly because the department was empowered to make a grant of a sewing machine on the completion of the course. It was also because the work could be carried out without interference with normal domestic ties and duties. Training in cookery, ladies' hair-dressing, confectionery, photographic studio work, and secretarial work was also given.

Applications received from disabled nurses were relatively few in number, as was to be expected, because those only were eligible who were in receipt of a disability pension under the Royal Warrant, and were not entirely disabled but physically unfit to practise as nurses. After the powers of the Ministry of Pensions were transferred to the Ministry of Labour in the autumn of 1919, 140 disabled nurses had by March 1921 been placed in training, out of 394 applicants. Some very sad cases were brought to light, many of the women proving physically unfit for the training desired, and for such application for assistance was made to the "Officers' Friend." Those remaining under training in March 1921 represented a great variety of occupations, including dispensing, massage and electrical treatment, public health appointments, secretaries and chauffeurs to doctors, poultry farming, etc.

**Training and Placing of Ex-Officers.**—The Appointments Department came into being during the war. Upon the Armistice its work developed very considerably both as regards training and placing in employment. In the first place, so far as training was concerned, under the decision of the War Cabinet given in Dec. 1918, funds were made available for higher educational training in universities, technical colleges, agricultural colleges, farms, professional firms, business houses, etc. The Board of Education, the Board of Agriculture and the Ministry of Pensions with the Ministry of Labour were made responsible for the administration of the scheme. The Appointments Department, by reason of its experience and provincial organization, operated as the machinery by which all the departments obtained information as to applicants, while the training for agriculture and higher educational training remained respectively with the Ministry of Agriculture and the Board of Education. The professional business and workshop training was transferred from the Ministry of Pensions to the Appointments Department. Under this scheme 17,311 ex-officers and men of similar educational qualifications had been placed by the Appointments Department in training at the end of Jan. 1921, while there were 1,864 waiting.

In connexion with the scheme selection committees were set up throughout the country, composed of prominent professional and business men in each district. The functions of these committees were to interview candidates who applied for grants and to make recommendations to a body known as the Grants Committee at headquarters. The final decision in such recommendations rested with the London Grants Committee.

These committees worked in turn in conjunction with what were known as Interviewing Boards, whose functions were (a) to decide what applicants properly came within the purview of the Appointments Department; (b) to advise applicants as to their prospects of obtaining employment, and (c) to select applicants as candidates for the vacancies on the books.

So far as placing was concerned, upon demobilization the department undertook the work of acting as official agent between employers and their former employees, who were either officers or men of other ranks of similar educational qualifications. In this capacity the department facilitated the return to their pre-war employment of 169,321 men up to March 26 1919. In addition to this the department undertook special activities with a view to finding new appointments for ex-officers, and up to the end of Jan. 1921 it found employment for 48,860 men, with 10,720 men remaining unemployed.

**Resettlement of One-Man Businesses.**—In May 1916 the Military Service (Civil Liabilities) Department came into being to help the wives of serving soldiers where military service imposed serious hardship. The scheme was limited to men who had joined the forces since Aug. 4 1914. The general items in respect of which assistance was granted included rent, mortgage interest, payment in instalments of contracts such as the purchase of premises, business or furniture, rates and taxes, insurance premiums and school fees. The maximum amount granted was not to exceed £104 per annum. Up to the conclusion of this scheme on July 31 1920, 475,271 applications had been received and 312,810 grants had been made to a total value of £6,239,670. In Feb. 1919 the Government decided to extend the principle of this scheme with a view to resettling men in their previous businesses when they were, as a result of military service, suffering serious financial hardship. The scheme as amended took two forms: current assistance could still be given in respect of liabilities such as those mentioned above, or alternatively, a lump sum grant towards the restarting of a business might be given.

So far as the second class of case was concerned, the Civil Liabilities Department was not empowered to pay resettlement grants for new businesses except in the case of disabled men. In that case alone the disability was in itself treated as serious financial hardship, and powers were given to make grants for those men in respect of new businesses. Under this scheme up to the end of Jan. 1921, 251,259



applications were received; 95,651 grants were made at a total expenditure of \$2,675,665. In addition there was a special scheme for providing tools for workmen who had to return to their pre-war occupations. Under this scheme \$21,562 was paid out.

(H. W.F.)

UNITED STATES.—United States troops continued to embark for Europe until the signing of the Armistice Nov. 11 1918. At that time, according to the final report of Gen. Pershing, 2,071,463 officers and men had sailed to serve with the A.E.F. and only some 15,000 had returned to the United States. According to figures compiled by the War Department, the total number of officers and men encamped in the United States on that date was 1,634,499 and more than 300,000 additional men had been ordered to be in camp before Nov. 30 1918. All draft calls were at once cancelled. On Nov. 26 orders were issued for immediate demobilization of the Students' Army Training Corps, which had been introduced Oct. 1 in about 500 colleges and universities throughout the country. This led to the discharge of some 150,000 students during December.

The question of general demobilization presented serious difficulties, and precedent offered slight help toward their solution. It was recognized that with peace would come a drastic curtailment of production in many industries, and it was feared that this curtailment and the sudden release of large numbers of soldiers would result in wide-spread unemployment and suffering. On the other hand the retention of a large army no longer needed would impose an unjustifiable financial burden upon the country. It was decided to discharge all emergency troops as rapidly as they could be dispensed with; but at the same time the Department of Labor was requested to watch carefully the labour situation, so that if desirable the rate of discharge might be reduced locally or as a whole.

The method of demobilization finally adopted differed from that employed by the European Allies. The plan of release by military "classes" based on age and length of service, natural in France and Italy, could not be applied in a country where the system of universal military service was unknown. It would have caused needless delay to attempt demobilization of the A.E.F. before beginning the release of men encamped in the United States. Neither was it feasible to follow England's system of "industrial demobilization." Profiting by the early mistakes of her Allies, America had not drafted indiscriminately into immediate service "key or pivotal men" from essential industries, but had placed them under deferred classification. Any attempt to demobilize by different occupations would have caused useless delay and might have impaired seriously military units overseas. It was therefore decided to demobilize by complete military units. In this way men returned to America under their own officers in orderly fashion. From the beginning, however, attention was given to individual requests for discharge, especially from American camps, if it appeared that men were needed by their families or their service required for industries. Speed of return from overseas was governed solely by transport facilities. About one-half of the American troops had been carried across in British vessels, which now were needed for home and colonial service. At the time of the Armistice transports belonging to the U.S. Government had a capacity of only about 110,000 a month. This was now rapidly increased by the release of battleships and cruisers. Use was made also of German passenger ships, and arrangements were made for the use of Italian, French, Dutch, and Spanish vessels. On June 30 1919, 173 vessels were in use as transports. After the Armistice embarkation camps were organized at Bordeaux, Brest, and St. Nazaire, and later at Havre and Marseilles. Le Mans was selected as a centre of distribution for the ports, and accommodations were ordered there for 230,000 men. There was considerable complaint of congestion and inadequate care of troops, especially at Brest, where there were normal accommodations for only 55,000 men, although that port alone was available for the largest transports. In America, Boston, Charleston, Newport News, and New York City were chosen as ports of debarkation.

Troops began to land in America in large numbers Dec. 2 1918, when the "Mauretania" reached New York with 4,000.

By June 3 1919 there remained in France only 694,745 officers and men. The A.E.F. headquarters were closed in Europe in Sept. on the departure of Gen. Pershing. Practically the last remnant of the A.E.F. in France embarked with Brig-Gen. Connor in Jan. 1920. There remained in Europe, besides the Graves Registration Service and special commissions, only the Army of Occupation in Germany. By June 30 1920 troops in Europe had been reduced to below 17,000.

Camps and cantonments in the United States formerly used for mobilization were converted into centres of demobilization, and to these were sent troops from overseas as well as those at home. Efforts were made to send each man to the demobilization centre nearest to his home or place of enlistment. Each man was given a rigid physical examination and those suffering from contagious disease were detained until there was no longer danger of infection. Discharge papers were prepared, accounts carefully settled, and an allowance of five cents a mile made each man from camp to his home. To encourage immediate return a reduced railway fare of two cents a mile was conceded those who departed within 24 hours after discharge. During the first three months of demobilization discharge required from four to seven days, but this was soon reduced to an average of two days. Gradually it was possible to reduce the number of centres, and beginning Nov. 25 1919 troops in America were discharged where stationed. Only two large centres were retained, Camp Dix, N.J., and the Presidio in San Francisco, for the use of troops returning from overseas, and even these were dispensed with after March 15 1920.

The following table prepared by the War Department shows the rapidity of general demobilization, month by month and cumulatively during the first year.

1918.	Officers.	Cumulative.	Enlisted Men.	Cumulative.
Nov. 11-30. . . .	593	593	43,000	43,000
Dec. . . . .	37,043	37,636	609,000	646,636
Jan. . . . . 1919.	23,563	61,199	358,000	1,010,000
Feb. . . . .	14,913	76,112	263,000	1,273,000
March . . . . .	11,479	87,591	203,000	1,476,000
April . . . . .	12,185	99,776	203,000	1,679,000
May . . . . .	14,622	114,398	383,000	2,217,000
June . . . . .	13,588	127,986	391,000	2,608,000
July . . . . .	16,404	144,390	361,000	2,969,000
Aug. . . . .	15,986	160,376	151,000	3,120,000
Sept. . . . .	8,716	169,092	73,000	3,193,000
Oct. . . . .	8,690	177,782	33,000	3,226,000

The cost per man of demobilization varied from month to month because the uncertainty of the number of men to be handled required the keeping up of all the demobilization machinery; for March 1919 it was \$60.95 but for June only \$20.27.

At each demobilization centre were stationed representatives of the U.S. Employment Service, and if the discharged man had no prospective job he was registered and a card given him for the local service representative nearest his own home. The Employment Service attempted to coordinate and cooperate with various local organizations, such as chambers of commerce, boards of trade, and patriotic and welfare societies. In Baltimore, Boston, Chicago, New York, and some other large cities, large bureaus were created for securing work for returned soldiers, sailors and marines. It is impossible to estimate the number of places secured through these agencies, as few kept accurate records. But the Employment Service alone, during the 10 months from Dec. 1 1918 to Sept. 27 1919, registered 758,474 men and secured employment for 474,085. It was seriously handicapped, however, by lack of adequate appropriations in 1919 and its operations were practically suspended after October. Although there were some industrial centres which, immediately after the Armistice, experienced a degree of depression, business as a whole was prosperous with the result that the great mass of the returning soldiers, many of whom returned to their old jobs, had little difficulty in finding employment. There was, of course, a certain percentage of discharged men who found it difficult or irksome to adjust themselves again to the conditions of civilian life; these were inclined to drift to the large cities, even though the opportunity for getting employment there was often less favourable than elsewhere. The surprising thing was not that a comparatively small number was unable to get work, but that so large a number could be absorbed without at any time causing an acute unemployment problem. One method early proposed for helping discharged men was that of awarding a soldiers' bonus. The Federal House of Representatives passed a Bonus Bill May 29 1921 by a vote of 289 to 92. The bill carried an appropriation of \$1,600,000,000. Protest, however, arose throughout the country, largely due to the prospect of a great increase in taxation; and the Senate took no action. At its national conventions held in 1920 and 1921 the American Legion was almost unanimous for a bonus for all who had served. Several states have acted on their own initiative and voted on the question of granting a bonus to their citizens who served. According to statistics gathered

for *The American Legion Weekly*, up to the middle of May 1921 some form of bonus had been granted in 13 states, namely, Maine, Massachusetts, Michigan, Minnesota, New Hampshire, New Jersey, New York (later declared unconstitutional), North Dakota, Rhode Island, South Dakota, Vermont, Washington, and Wisconsin. The payment provided varied. In several states a lump sum of \$100 was awarded. In most cases the veteran received a fixed amount for each month of service (usually \$10 or \$15) up to a maximum (varying from \$120 to \$600). Bonus bills had been defeated in 11 states, namely, California, Colorado, Connecticut (relief fund provided, the interest of which is to be used for needy men), Delaware, Indiana, Maryland, Oklahoma, Tennessee, Texas, West Virginia, and Nebraska (relief fund provided, interest to be used for relief). No legislation was contemplated in 14 states, namely, Alabama, Arkansas, Georgia, Idaho, Kentucky, Louisiana, Mississippi, Nevada, New Mexico, North Carolina, South Carolina, Utah, Virginia, and Wyoming. In the other states preparations were being made to act upon the question.

*The American Legion.*—While the World War was still in progress there arose spontaneously among the American soldiers a wide-spread desire that with the coming of peace there should be created a permanent organization for perpetuating their feeling of comradeship and its ideals. Active steps toward this end were first taken at a caucus held by a number of service men in Paris March 15-17 1919. This was followed by another caucus held in St. Louis May 8-20 1919, when preliminary organization was effected and the name "The American Legion" adopted. Incorporation was secured by an Act of Congress Sept. 16 1919. The first annual convention was held at Minneapolis Nov. 1919. The purpose of the Legion, according to its constitution, is: "To uphold and defend the Constitution of the United States of America; to maintain law and order; to foster and perpetuate a one hundred per cent Americanism; to preserve the memories and incidents of our association in the Great War; to inculcate a sense of individual obligation to the community, state, and nation; to combat autocracy of both the classes and the masses; to make right the master of might; to promote peace and good will on earth; to safeguard and transmit to posterity the principles of justice, freedom, and democracy; to consecrate and sanctify our comradeship by our devotion to mutual helpfulness." The organization is non-sectarian and non-partisan. Any man or woman is eligible to membership who was in the military or naval service of the United States between the dates April 6 1917 and Nov. 11 1918 inclusive; also "all persons who served in the military or naval services of any of the Governments associated with the United States during the World War, provided they were citizens at the time of their enlistment and are again citizens at the time of their application." Exception is made of persons dishonourably discharged from service, as well as persons who refused to perform military duty "on the ground of conscientious or political obligation."

At the head of the Legion are a national commander and five national vice-commanders, elected by the national convention. The active director at headquarters is the national adjutant-general. Each state also is organized under a state commander and other officers. The local unit is called a post. On Sept. 30 1921 the number of posts was 10,795, located in every state of the Union and in the District of Columbia, the Philippines, Panama, Cuba and many other countries, including Canada, Mexico, Argentina, and France. The total membership at the same date was about 785,000.

The Legion strongly endorsed the proposed Federal bonus for all ex-service men; and, especially through its National Legislative Committee, was influential in giving publicity to the needs of disabled soldiers and in securing legislation in their behalf. To its efforts, in part at least, were due the enactment of the Sweet bill, providing for the Veterans' Bureau; the Veterans' Hospital bill, appropriating \$18,600,000 for building or improving hospitals for ex-service men; the publication of lists of draft evaders in the *Congressional Record*; the bringing to the United States of the body of an "Unknown Soldier" for burial in Arlington National Cemetery; the bestowal of the Congressional Medal of Honor upon the British "Unknown Soldier" buried in Westminster Abbey, and upon the French "Unknown Soldier" buried under the Arc de Triomphe. The official publication is *The American Legion Weekly*. The Women's Auxiliary had a

paid-up membership of 107,345 on Sept. 1 1921. At the national convention of the Legion in 1921 distinct organization was effected, and separate officers and headquarters were chosen.

DE MORGAN, WILLIAM FRIEND (1839-1917), English novelist (see 8.10), was born in London Nov. 16 1839 and educated at University College school and later at the college itself. He became a student at the Royal Academy in 1859 and in 1864 began the study of stained glass. Six years later he turned to ceramic work and soon became known in artistic circles as a potter, the "De Morgan" tiles being made remarkable by his rediscovery of the secret of some beautiful colours and glazes. But later in life he became even better known to the literary world through his novels, *Joseph Vance* (1906); *Alice for Short* (1907); *Somehow Good* (1908); *It Never Can Happen Again* (1909); *An Affair of Dishonour* (1910); *A Likely Story* (1912); *When Ghost meets Ghost* (1914), in which the influence of Dickens and of his own earlier family life were conspicuous. He died in London Jan. 15 1917. In 1919 *The Old Madhouse* was published posthumously. His last but unfinished novel, *The Old Man's Youth*, was published, with additions by his widow (1921).

DENBY, EDWIN (1870- ), American public official, was born at Evansville, Ind., Feb. 18 1870. His father, Charles Denby (d. 1904), was minister to China 1885-98. He was educated in the Evansville schools, went to China with his father in 1885, and two years later entered the Chinese imperial maritime customs service. He returned to America in 1894, graduated from the Law school of the university of Michigan in 1896, was admitted to the bar and thereafter practised in Detroit. On the outbreak of the Spanish-American War in 1898 he entered the navy, and as gunner's mate saw action at Santiago. Later he was a member of the Michigan House of Representatives. From 1905 to 1911 he was a member of the National House of Representatives and was allied with the conservative Republicans. He served as chairman of the House Committee on Naval Affairs. When America entered the World War in 1917 he enlisted at the age of 47 as a private in the Marine Corps and was sent to the training station on Paris L. S. C. He was advanced to corporal and sergeant and was highly successful in training recruits. In Jan. 1918 he was commissioned second-lieutenant and passing through the various stages, before the end of the year had been promoted major. After the close of the war he was appointed probation officer of the Detroit Municipal Courts. In 1921 he was appointed Secretary of the Navy.

DENIKIN, ANTON (1872- ), Russian general, was of humble descent and held democratic views. After going through the usual military training and service he joined the Russian general staff, and in the earlier period of the World War he rose to the rank of lieutenant-general and to the command of a division on the Danube front. During the Russian revolution he followed Kornilov, and was for some time chief of his staff. He was arrested with Kornilov and imprisoned in Bykova. They escaped together and fled to the Caucasian shore of the Black Sea. There he joined Alexeyev, who was forming a small army of volunteers, chiefly composed of officers. On Kornilov's death (March 31 1918) he became the military commander of the army, while Gen. Alexeyev held power as "Supreme Leader" of the Government and organized recruiting and supplies. They collected the army on the southern border of the Don region, at Metchetinskaya, and established coöperation with a Caucasian detachment, led by Erdeli, with the Don Cossacks under Krasnov, and some 2,000 men who had marched right through the southern steppes under Drozdovsky. By June the army counted some 12,000 men and was able to attempt the reconquest of the Kuban territory. Things had changed considerably since March, when Kornilov's invasion came to a standstill in front of Ekaterinodar. The Kuban Cossacks had had time to ascertain the true character of Bolshevik occupation, and the volunteers moved down the Rostov-Vladikavkaz line and the Black Sea line from Tikhoryetzkaya to Novorossisk. The Reds, in spite of their numerical superiority, melted before this advance and one *stamisa* (camp settlement) after the other joined the invaders. On Aug. 5 Gen. Alexeyev entered Ekaterinodar, the capital of the Kuban



and practically all the resources of the prosperous country were henceforward at the service of the volunteers. By the middle of Sept. the army had increased to 60,000 men. The Germans, whose garrisons had advanced to Rostov at the mouth of the Don, did not look on that extension with friendly eyes; they did their best to disintegrate the volunteer fighting forces, and at the same time tried to induce Alexeyev and Denikin to accept a condition of vassalage, similar to that which had been submitted to them by the Don Ataman, Krasnov. But nothing of the kind was possible in the case of Alexeyev and Denikin: their whole energy was directed towards a patriotic reconstruction of Russia, and they declined all overtures from the crafty foe. On Sept. 25 Alexeyev died after an illness which he had contracted during the World War, but against which he had struggled by sheer devotion to his task, never sparing himself, never relaxing his efforts. It was impossible to replace fully this man, who resembled one of the heroes of antique virtue. Denikin, who had to step into the breach, was not Alexeyev's equal in military genius or in statesmanship, but he was worthy of his predecessor in purity of character and in his sense of duty.

The revolt of Siberia and eastern Russia against the Bolsheviks prevented the latter from concentrating their forces against the dangerous volunteers, and the Germans were at the end of their tether in the struggle with the western Allies, and unable to use their position in Russia to any useful purpose. These favourable circumstances made it possible for Denikin to spread his wings wide. The Don Cossacks joined him, he established communications with Astrakhan and Ural Cossacks and the Orenburg province on the right, while on the left, his lieutenant Schilling moved towards Kiev and Odessa. There was some very heavy fighting in the centre, where Stavropol was taken after a struggle of several days, and 35,000 Reds surrendered or were exterminated. Towards the beginning of 1919 Denikin was master in the S. of Russia, and could begin to organize a base for an attack on the main block of the Soviet Republic. The principal Cossack armies had congregated round the nucleus of the Volunteer army. The latter had unfortunately suffered grievous losses in the ceaseless fights of the Civil War, which it had to conduct in miserable equipment, with hardly any ammunition except that which was taken from the enemy, in hunger and cold; some 30,000 of its best men had fallen, and these could not be replaced either by conscripts, driven in by command, or by the Cossacks, who could fight well when they chose, but who did not always want to do so. The difficulty of the political situation became apparent when the question of an arrangement between the various forces under Denikin was seriously raised. On Nov. 1 Gen. Denikin met the Regional Assembly (*Krayevaya Rada*) of the Kubañ territory. He made a powerful speech in which he said, among other things:

"Can there be any peace politics on the Kubañ? Will your long-suffering settlement be safe from a new and more cruel invasion of the Bolsheviks when the Red power establishes itself firmly in Moscow, when it throws back by weight of numbers the Volga front, when it presses on the Don from north and east and when it moves towards you?—No! It is time that people should cease to wrangle, to intrigue, to seek precedence. Everything should be sacrificed for the sake of the struggle. Bolshevism must be crushed, Russia must be liberated. Otherwise your well-being will not prosper, you will become the plaything of the enemies of Russia and of the Russian people. . . . There can be no talk of separate armies—the Volunteer army, the Don army, the Kubañ army, the Siberian army. These should be one army—the Russian one, and also one front, one Chief Command, endowed with full power, responsible only to the Russian people, as represented by its future supreme authority."

The speech did not produce the desired effect. It was criticized in the lobbies by separatists and by Socialists, but it was at least conceded to the Commander-in-Chief that a Government should be formed in which ordinary provinces, like Stavropol or the Black Sea district, should be subjected to an emergency military régime, while the Kubañ and to some extent the Don should be governed by independent institutions, though maintaining a kind of federal allegiance to the High Command. The Kubañ obtained, in fact, political autonomy, but agreed to place its forces under the command of Gen. Denikin. Yet the Ukrainian

elements of the Rada contrived to send a special mission to Paris, and negotiated there with representatives of the Allies independently of the Russian "Political Council" and of S. D. Sazonov, the Foreign Minister of the South Russian Government.

For the conduct of the Government Gen. Denikin formed a "Special Council," which combined legislative and executive functions. It consisted of generals of the headquarters staff and the heads of departments, some 18 or 20 in number (Gen. Dragomirov, Lukomsky, Romanovsky, etc.); the civil members—Neratov, J. P. Shipov, N. Astrov, Stepanov, K. Sokolov, M. M. Fedorov, etc.). Most of the members belonged to the so-called National Centre and to the moderate Right. The Left was represented by four Cadets, of whom, however, two had drifted a good deal to the Right. The weight of authority rested with the generals, but there were long discussions and many compromises. It was attempted to steer a strictly "business course," politically colourless, but the Government did not succeed in achieving popularity. Gen. Denikin regarded this Assembly as a consultative organization, and gave his decision after listening to proposals and discussions. He insisted on keeping military restoration to the fore until the Bolsheviks had been laid low or at least until Moscow had been liberated. No pronouncement was allowed as to the form of Government, but the authority of the old Constituent Assembly, which was attempting to gather power in Ufa and Omsk, was rejected as the product of popular insanity. On the whole the Government was clearly leaning towards the Right, but Denikin was averse to any kind of acts of violence and oppression; his rule was, however, not free from contradictions and lacked political initiative. He followed the current more than he directed it.

His military plans were based on the idea that if he succeeded in driving the Bolsheviks out of the Russian provinces the population would reform behind his lines and set up compact patriotic levies against the hateful usurpers. With this purpose in view he pushed forward rapidly in all directions, and it seemed at first as if events justified his previsions. The Bolsheviks were driven back everywhere by the Volunteers and the Cossacks. When they rallied in the East and made a determined attempt to retake Tsaritsyn and turn the line of the Don they were repulsed and finally routed by Gen. Wrangel's Caucasian army. The Cossacks of Mamontov and Shkuro made raids deep into the lines of the enemy; officers and soldiers of the Red army deserted in thousands to the Whites; the population met Denikin's hosts as liberators with processions and the ringing of bells. Kursk, Kharkov, Voronezh, were occupied, and in July the advance guard reached Orel, some 300 m. from Moscow.

This rapid progress proved deceptive. The armies of liberation did not bring law and order with them. Not only were Commissars and prominent Bolsheviks given short shrift, but officers who had served in the ranks of the Reds and gone over to the Whites were subjected to irksome investigations and delays before obtaining "rehabilitation." The badly equipped and badly supplied troops laid hands on all sorts of goods and stores; it was hard to distinguish between requisition and looting. Such administrators as were introduced by the advancing army were more intent on bettering themselves than on looking after the population; the peasants felt themselves menaced by the revenge of the squires.

The people, driven to despair, took to flight, and the more adventurous among them formed "green" bands, which roamed about the country, seized stations, stopped trains, cut off provision columns. The most daring of these brigands, Makhno, made Ekaterinoslav his capital, and nearly overran Rostov in the summer of 1919. The most threatening symptom of all was the lack of union between the various sections of the Whites. The Kubañ was preparing for complete independence and negotiating with the Mahomedan mountaineers for a league. Denikin found it necessary to strike hard against the Separatists; the Rada was dissolved; one of the leaders, Kalabukhov, was shot as a traitor, and a new Government was formed from among the supporters of a closer union with the Russian army (Nov. 1919). The "line" Cossacks were favourably disposed, but the *comp d'état* did not succeed in uprooting the movement for an in-

dependent Kuban republic in the south-west. On the contrary, the Separatists, though forced for a time to conceal their aspirations, were embittered, and resolved to wreck the combination with the Volunteers.

In the meantime the resistance of the Reds stiffened in proportion as the Whites lost the sympathy of the people. Soviet propagandists had no difficulty in rousing the apprehension of the Great Russian peasants against the advance of the "squires"; officers of the Red army became less keen to desert when they ascertained that they would be treated as suspects by Denikin's lieutenants. The relentless discipline re-introduced by Trotsky in the Red army was backed by the action of select bodies of privileged troops—international contingents of Letts, Chinese, Magyars, etc., picked Communist battalions, large bodies of cavalry trained for rapid marches and sudden concentrations against weak points of the line. In the beginning of Nov. Budenny's cavalry corps broke through the White lines at Kopyansk and threatened to cut off the Volunteer army from its base on the Don. The line rolled back and a general retreat set in. Denikin tried to stem the back flow by appointing Wrangel to command the Volunteer army in the place of Mayevsky, who had been indulging in reckless debauchery in Kharkov. But Wrangel was not a magician who could mend the consequences of errors which he had detected and criticized from the beginning. Town after town fell, and there was no hope of support from the Poles, who were by no means inclined to fight for the restoration of Russia. A British political mission headed by Sir Halford Mackinder, M.P., was more concerned with promoting the interests of Georgia, Armenia and Azerbaijan than in taking up the cause of Russian centralization. In these dire straits Denikin resolved to abandon his former policy in regard to the Cossacks, and summoned a central "Krug" (circle) of the Cossack armies—Don, Kuban, Terek, Astrakhan—with the object of starting a new Government on federal lines. It was agreed that there should be a Legislative Assembly of the Federation, and that Denikin should act only as Chief of the Executive and Commander-in-Chief. Even this surrender did not help. After a last success of the Volunteer army, which retook Rostov (Feb. 8), the final catastrophe came through a defection of Kuban Cossacks on the right flank, of which Budenny's cavalry took full advantage. Rostov and Ekaterinodsk had to be abandoned. Crowds of refugees gathered in Novorossisk in the first months of 1920; spotted typhus raged among them. The remnants of the Black Sea fleet and foreign ships carried loads of these wretched people to the Prinkipo Is. and to Lemnos, and Denikin himself left for Constantinople.

By way of an epilogue to the drama of discord which had embittered the minds and paralyzed the efforts of the Whites, Denikin's Chief of the Staff, Gen. Romanovsky, was murdered by two officers of the Volunteer army on the steps of the Russian embassy in Constantinople. He was a quiet, industrious man, who had come to recognize that there was no Conservative class in Russia capable of serving as a basis for government. He was therefore in favour of a closer alliance with the Moderate Socialists. This was an unpardonable heresy from the point of view of the Rights, and it was from this side that the shot came which put an end to the life of Denikin's trusty assistant. (P. VI.)

**DENIS, MAURICE** (1870- ), French painter, was born at Granville, Manche, in 1870. He studied at Julian's Academy and at the Ecole des Beaux-Arts. As a student he came under the influence of Paul Sérusier, one of Gauguin's associates at Pont Aven, and became a prominent member of the *symboliste* group which included also P. Bonnard, K. X. Roussel and E. Vuillard. Inspired mainly by Cézanne and Gauguin, the *symbolistes* represented a reaction against impressionism, in favour of synthesis and the use of form and colour to express subjective states of mind. Denis was also associated with the *Rose Croix* group which aimed at substituting an idealist decorative art for the realism of the day. To these influences was added that of Italian quattrocento art, as the result of a visit to Italy in 1894. Denis early turned his art to religious purposes, but classical mythology has also frequently provided him with subjects. His most important work is his mural decorations, which include decorations for the chapels of the church of Vésinet (1899-1903); "L'His-

toire de Psyche," five panels for M. Morosoff, Moscow (1908); "L'âge d'or," five panels for a staircase of the Prince de Wagram (1912); a frieze for the cupola of the Théâtre des Champs Elysées illustrating in four panels the history of music (1912); decorations and stained glass for the church of St. Paul, Geneva (1917-8); and a decoration for La Chapelle du Souvenir in the church of Gagny (1920). All these works show the influence of quattrocento Italy in the linear character of the design, and the preference for spare, stiff, angular forms, which connect Denis with Puvis de Chavannes. His colour, however, is much more vivid than that painter's, and shows an impressionist palette and method of handling. An artist of great fecundity, Denis has also produced many easel pictures including a "Homage à Cézanne" (1901), somewhat in the manner of that painter; a portrait of Degas; and a long series of religious subjects typified by "La Meilleure Part" (1920). He has also illustrated among other books, Paul Verlaine's *Sagesse* (1891-1910), *The Imitation of Christ* (1903), and *La Vita Nuova* (1908). His frequent contributions on art to the reviews were republished in 1912 in *Théorie 1890-1910*, which contains much interesting comment on modern art. Denis has chiefly exhibited at the Société Nationale, of which he became full member in 1902, at the Salon des Indépendants, and at the Salon d'Automne. He is represented in the Luxembourg, Paris. In 1910 he was made Chevalier of the Legion of Honour.

**DENMARK** (see 8.23).—Since the incorporation of North Slesvig (1,496 sq. m.), returned to Denmark in 1920 according to the Treaty of Versailles, the area of Denmark proper is 16,958 sq. miles. About 75% of the area is occupied by cultivated land, about 10% by woods and plantations, while the rest, 15%, is either uncultivated or is used as gardens, building lots, roads, etc. Besides, the Faeroes (540 sq. m.) and Greenland (a little more than 770,000 sq. m.) belong to Denmark.

**Population.**—Since the incorporation of North Slesvig Denmark proper has something over 3,200,000 inhabitants, of whom about 150,000 live in North Slesvig. The Faeroes have 20,000 and Greenland about 13,000 inhabitants. In Denmark proper, apart from Slesvig, the density of pop. is 195 per sq. m. (325 per sq. m. on the islands, 127 in Jutland). One-fifth of the pop. lives in the capital, about another fifth in the provincial towns and about three-fifths in the country. The average death-rate in the years 1910-9 was about 13 per thousand, the average birth-rate 25 per thousand. Before the World War the overseas emigration was some 7,000 persons a year. In war-time it fell off, in 1918 to 800, rising again to 3,300 in 1919. The yearly increase of pop. is a little more than 1%, the average percentage of the years 1910-9 being 1.11. On the basis of the statistics of the years 1911-5, the average duration of life has been calculated at 56.2 years for men and 59.3 years for women, while 75 years earlier the figures were 40.9 and 43.9.

**Communications.**—The total length of roads in 1919 was about 28,000 m., some 4,300 m. being main roads. There were in 1921 about 2,700 m. of railways (Slesvig excepted), of which one-half was under State administration. Motor-cars numbered about 18,000, including about 2,300 taxis and omnibuses, 3,800 commercial vehicles and 12,000 motor-cycles.

**Occupations.**—In 1911 36% of the population were engaged in agriculture (horticulture, forestry and fishing included), about 27% in industry and manufactures and about 17% in commerce and transport. The remaining 20% included those occupied in different trades or in non-productive work, domestic servants, independent persons and those supported by the State. In 1901 some 40% of the population lived by agriculture and 14% by trade, transport, etc. Since 1911 this movement from agriculture towards other occupations has been on the increase.

**Legislation.**—In Sept. 1917 a joint-stock companies Act at last was passed, introducing directors' liability, public registration, protection of the rights of the minority, and public accounts.

**Agriculture.**—By a law of 1919 land held as fief or by entail, large estates formerly undivided in succession (*Lehn*), was made freehold property. Owners must deliver to the Treasury part of the capital value of the estate and—on compensation—hand over to the State one-third of the fields for small holdings. In the same year it was decreed that property still held on lease should become freehold. This legislation, especially the Acts of 1919, concerning the parceling-out of lands previously in the possession of the State and of entailed property passing into free possession, was a continuation of the movement, begun by the Cottars' Allotment Act of 1899, towards establishing a number of independent small holdings; in 1899 the idea was two acres and a cow; now legislation aims at 20 ac.; from 1899-1919 some 10,000 new small holdings had been established, the State holding the secondary mortgages.

In the middle of the 19th century the market price per *Tønde Hartkorn* (Danish unit of land valuation, equal to 18 ac. good soil) was about 2,000 Danish kroner; in the first half of the 'eighties 6,500 kr.; prices declined till towards the close of the century, the price then being 5,200 kr., rising later to about 8,500 kr. in 1913. A constant rise took place during the war, prices in 1918 reaching 12,800 kr. per *Tønde Hartkorn*. This decline of prices from the middle of the 'eighties to the close of the century, due to the general fall in corn prices, was met by a change of the whole system of agriculture in consequence of which milk, butter, bacon and seed took the place of corn and live stock as chief product. This development continued until the outbreak of the World War. The new industries were based on the use of home supplies together with imported grain and artificial manure, the result being a very considerable output, especially of dairy produce, pork, eggs, cattle and horses. Only a part was marketable in Denmark itself, and a considerable export trade was developed, dairy products, pork and eggs mostly going to England.

During the war, and after the beginning of the ruthless submarine campaign, conditions were altered, the importation of raw materials being very much impeded. The import of corn and forage, including oilcake, amounted before the war to 1,700,000 tons annually, while Denmark's home production was 2,400,000 tons of grain: allowing 500,000 tons for food supplies and for industrial purposes, about 3,300,000 tons remained for forage. During the war the import of rye, maize, and oilcake partly, and in 1918 almost totally, failed; moreover, the harvest in the country was reduced by one-sixth owing to the want of artificial manure. Denmark was compelled to reduce its live stock. The number of cattle was in 1914 2,500,000 and after 1917 two million. Notwithstanding that the best milk cows were least affected by this reduction of stock, the output of milk and subsequently of butter was reduced by about 50%. Butter from 117,000,000 kgm. in 1914 to 67,000,000 kgm. in 1918. But while in 1914 about 95,000,000 kgm. were exported, in 1918 only 15,000,000 kgm. were sent out of the country. Home consumption of butter was much more than doubled—due to the stoppage of the import of copra, the raw material for margarine. The number of swine, in 1914 about 23 million, almost equalling the number of the population, was in 1917 reduced to 13 million and in 1918 to half a million. This reduction manifested itself in the rapidly decreasing export of pork, from 150,000,000 to 3,000,000 kilograms. The number of hens fell between 1914 and 1918 from 15 million to 9 million, export of eggs being in the same years 450 million and 320 million respectively. The number of horses and sheep was almost undiminished, about 500,000 of each.

After 1918, with the coming of peace, Danish agriculture recovered rapidly, but the production, especially of pork, was still in 1921 less than before the war. The butter and pork production is mainly in the hands of the farmers' own cooperative factories; thus, of the 1,380 Danish butter factories 1,168 are on a cooperative basis and about 90% of the swine killed in Denmark are taken to the cooperative slaughter-houses.

Two important laws relating to agricultural exports were that of May 27 1908, dealing with the control of meat exported from Denmark, and a similar law of April 13 1911, dealing with the control of butter. They were based on section 62 of the British Trade-Marks Act 1905, which enabled Danish farmers to register a common trade-mark as against all other trade-marks in these articles. Thus all exported meat or bacon receives a public trade-mark and a Government stamp showing it to have been passed for export at the control station either as first- or second-class produce. Agricultural goods for export can therefore receive an official trade-mark certifying the quality of the articles. No butter is allowed to be exported that contains over 16% of water, or other preservatives than salt.

**Industry.**—Manufactures dependent on the import of coal and raw materials did not develop in Denmark until about the last decade of the 19th century, as the country produces no coal and very little raw material apart from farm products and material for brick- and cement-making. It thus happens that Denmark as a whole is the loser in the years of high prices and so-called prosperity when the raw materials having to be bought abroad at the highest price level—and repairs the losses in the years of depression. The rather small-sized factory is typical, but some big factories have been established in connexion with the manufacturing of leather and footwear, cement, margarine, textiles, tobacco, spirits, sugar, beer, oil, matches, paper, agricultural machines and iron ships. Of the 140,000 persons engaged in factories employing more than 20 working-hands in 1914 more than half belonged to Copenhagen. Most of the larger establishments belong to joint-stock companies. In 1919 there were 994 industrial joint-stock companies with a total capital of 621,000,000 kr., of which three-fourths belonged to companies with a capital exceeding 100,000 kr. each. During the last decades Danish industry has shown an increasing tendency towards centralization. Customs duties were considerably reduced in 1908, but as they are almost always calculated upon weight, the general advance in prices made the protection left to industry completely ineffective. During the blockade industry had to face difficulties regarding the importation of raw material and coal; but the blockade mainly affected industries producing oils and margarine, which were practically at a standstill in 1918. The

failure of the coal supplies was met with the strictest economy in consumption and partially made up for by an energetic utilization of the native fuels—woods, peat and brown coal. In spite of heavy difficulties, Danish industry was to a large extent able to supply the demands of the home market.

On the whole the war period must be said to have been economically favourable to the neutrals, as appears from the formation of a number of new industrial concerns and the extension of many of those already in existence, and the fact that between 1914 and 1920 the number of companies increased by 50% and their capital by 150%. Industrial profits were largely invested in extensions and improvements which could not be turned to full account during the post-war depression. The following table shows the total number of persons, the number of skilled workers, and the horse-power of prime movers concerned in the principal industries in the year 1914:

	Total Number employed.	Skilled Workers.	Power. H.P.
Food . . . . .	63,000	38,000	81,000
Textiles . . . . .	17,000	14,400	16,300
Clothing . . . . .	65,000	35,000	3,500
Building and Furniture . . . . .	79,000	53,000	21,000
Woodwork . . . . .	13,300	6,000	18,000
Tanneries . . . . .	1,200	900	11,400
Earthenware and Glass . . . . .	20,000	16,000	28,000
Metals . . . . .	63,000	46,000	34,000
Chemical and Technical . . . . .	13,000	9,000	15,000
Paper . . . . .	3,500	3,000	7,600
Printing . . . . .	12,000	9,700	4,200
<b>Totals . . . . .</b>	<b>350,000</b>	<b>230,000</b>	<b>230,000</b>

**Shipping.**—At the close of 1913 Denmark's mercantile marine counted—apart from vessels of four-ton register or less—169 sailing vessels with a joint tonnage of about 90,000 tons register, 941 motor vessels of 30,000 tons register and 642 steamers of 430,000 tons register. At the close of 1919 the respective figures were 1,581 sailing vessels of 103,000 tons register, 1,465 motor vessels of 8,000 tons register, 514 steamers of 332,000 tons register. The number of Danish steamers sunk by submarines, torpedoes and mines was 147, representing a tonnage of 229,000 tons register in gross. The gross freight carried in Danish ships—excluding home coast traffic—amounted in 1913 to 110 million kr. and in 1919 to 445 million kroner. The average dividend on steamship shares was in 1919 70%. From 1916–20 foreign-going shipping of the country was controlled by a Freight Board, elected by the shipowners themselves. Rather generous maximum rates were fixed for the supplies of the country. Owners were bound to employ their ships according to the instructions of the board. In July 1917 an arrangement was made according to which all Danish owners put tonnage at the disposal of the Freight Board for the coal supply from the United Kingdom at a fixed rate and quantity.

**Commerce.**—The total imports and exports from 1912–20 were as follows:—

Year	Imports: Mill. kr.	Exports: Mill. kr.	Excess of Imports: Mill. kr.
1912	818	682	136
1913	855	721	134
1914	795	867	72
1915	1,157	1,120	28
1916	1,357	1,309	48
1917	1,082	1,065	17
1918	945	743	202
1919	2,519	909	1,610
1920	3,142	1,814	1,328

Thus it appears that the excess of imports over exports was in the years preceding the war about 130,000,000 kr., while in the first four war-years export and import were almost equal. Yet in 1914 on account of "hidden exports," the trade balance was actually favourable. In 1918 the balance was 200,000,000 kr., and in 1919 and 1920 it averaged 1,500 million kr. against Denmark. In the years 1914–8 the position was favourable, partly owing to the consumption of stocks and the selling-out of assets, such as the stock of domestic animals, and partly owing to the profits of shipping. It is only natural that the commercial and therefore the financial balance after the war should present a somewhat different aspect. Also it must be borne in mind that some of the war-time profits were invested in extensive purchases in order to replenish the empty warehouses; also considerable contracts were made with a view to subsequent exportation to the Baltic states, a possibility which, however, had not been realized in 1921, and involved many individual concerns in heavy losses. A comparison of the value of Danish imports for home consumption in 1913 and 1918, the last of the war-years, is as follows:—

Imports.

	1913		1918	
	Mill. kr.	Per cent.	Mill. kr.	Per cent.
Raw material for agriculture . . . . .	170	23	33	4
Raw material, etc., for industry . . . . .	130	16	183	20
Partly manufactured articles . . . . .	48	6	180	14
Articles of food or luxury . . . . .	148	19	56	6
Fuel and illuminants . . . . .	81	10	299	33
Articles of industry . . . . .	200	26	209	23
Entire import for home consumption . . . . .	777	100	910	100

The figures show the remarkable changes in the relative values of different imports arising in consequence of the war, but the varying advance in prices must also be taken into account, and the corresponding changes in quantities imported are not indicated. As for fuel, the yearly import before the war was about 3,000,000 tons, while during the war it fell below 2½ million.

A comparison of the exports during the normal year 1913 with the war-year 1918 gives the following:—

Exports.

	1913		1918	
	Quantity: Mill. kgs.	Value: Mill. kr.	Quantity: Mill. kgs.	Value: Mill. kr.
Butter . . . . .	91	200	15	113
Pork . . . . .	135	164	3	8
Eggs . . . . .	454	33	328	68
Horses (number) . . . . .	28,000	21	29,000	75
Cattle (number) . . . . .	152,000	48	114,000	70
Meat . . . . .	15	14	14	39
Other agricultural products . . . . .	—	71	—	150
Total . . . . .	—	357	—	523
Fish . . . . .	—	12	—	17
Articles manufactured . . . . .	—	74	—	170
Total . . . . .	—	637	—	710

The chief articles of export were the more or less manufactured agricultural products. But between 1913 and 1918 this export was so much reduced that, notwithstanding the great advance in prices, the total value declined. After the Armistice the export of farm products increased. The value of manufactured products and eggs exported was in 1920 about 900 million kr. and of live animals about 110 million kr. The butter export rose in 1920 to 75,000,000 kgs. and the pork export to 45,000,000 kilogrammes. The trade with foreign countries in 1913, 1917 and 1918 was as follows:—

Country.	Imports.			Exports.		
	1913 per cent.	1917 per cent.	1918 per cent.	1913 Home manuf. articles: per cent.	1917 Home manuf. articles: per cent.	1918 Home manuf. articles: per cent.
United Kingdom . . . . .	16	26	21	63	27	7
Germany . . . . .	38	22	33	25	50	43
Sweden . . . . .	8	13	25	2	9	23
Russia . . . . .	9	1	—	2	1	1
United States . . . . .	10	20	4	1	—	—
Norway . . . . .	1	3	5	2	6	16
Other Countries . . . . .	18	15	12	5	7	10

The export of home-made articles to the United Kingdom in 1913 was 398 million kr. of which butter (180 million kr.), pork (160 million kr.) and eggs (31 million kr.) made up 371 million kr., or more than 90% of the total. Exports to Germany were in 1913 valued at 150,000,000 kr., cattle and meat 65,000,000 kr., and hides 10,000,000 kroner. Before the war Denmark did most of its business with England and Germany, but during the war much business was done with the Scandinavian countries, especially with Sweden. A considerable part of the foreign trade in war-time was conducted by agreements between the countries concerned as to desirable interchanges of supplies. After the war foreign trade partly returned to pre-war lines. The import and export of raw materials and agricultural produce is largely conducted through the farmers' own cooperative organizations. During the war only a limited quantity of goods was admitted from England and America. Agreements to that effect were made with the United Kingdom in Nov. 1915 and with the United States in Sept. 1918, negotiations being conducted between the respective Governments and the Danish commercial and industrial organizations, "Grossersocietets Komité" and "Industriraadet." These organizations also distributed the imported quantities among such Danish firms as had hitherto been importing or using the articles in question. The export of agricultural produce is mainly conducted through Esbjerg or Copenhagen. Copenhagen is by far the most important com-  
mercial city. A part of the retail trade is in the hands of the peasants' own cooperative societies.

cial city. A part of the retail trade is in the hands of the peasants' own cooperative societies. Economic Legislation During the War.—Immediately upon the outbreak of the war, on Aug. 7 1914, the Government was authorized to take measures to ensure supplies and to prevent an unfair rise in prices. A special committee, was appointed for the regulation of prices and supply of necessities of life and of other articles, and export was either prohibited or required a licence. For such articles as butter, etc., the object of control was not merely to ensure the supply of the home market but quite as much the control and regulation of the export trade.

The special committee commenced immediately to forbid the use of rye and wheat for forage. Till that time home-grown grain had been largely used for feeding swine, horses, etc., bread being baked from imported corn, the supply of which completely ceased. In the winter of 1916 the use of sugar and in 1917 of potatoes for forage was prohibited. Licences for potatoes were, however, always granted when supplies for human requirements were sufficient. Maximum prices for home-grown rye and wheat were fixed about Christmas 1914. In May 1915 maximum prices followed for swine and pork. By order in council of Nov. 27 1916 it was notified that any advance in the prices of food decided on by mercantile unions or firms holding monopolies must be notified to and sanctioned by the special committee. On Jan. 31 1917 maximum prices were fixed for potatoes. Sugar production and prices were also placed under observation and control.

Thus Denmark had the distribution of commodities and maximum prices, especially of farm produce of importance to the home market, well under control before the blockade in its severest form took effect. Immediately upon the beginning of the blockade a general decree made it punishable for commerce to raise the percentage of profits above the level of 1914. On May 19 1917 orders were issued to prevent the enhancement of prices of commodities as a result of their having passed through more hands than necessary and customary (the so-called "chain-commerce"). The existing maximum prices were retained and new ones were fixed for a constantly increasing number of commodities. In the spring of 1916 the State had already taken possession of the corn harvest, but at the beginning of the blockade it took the sole control of the trade through the Board of Food Control, established in 1917. Before Feb. 1 1917 only sugar had been rationed but had not been materially reduced, home production almost equalling consumption. Grain was rationed in the spring of 1917 and pork in the autumn of 1917. Owing to the increasing scarcity similar measures were taken later with regard to butter, margarine, fuels, illuminants, benzine, coffee, tea, rice and other articles. The scarcity of fats made it necessary to introduce special regulations for the soap industry. At the same time maximum prices were fixed for the articles in question. Several other branches of industry were also put under control. After the war imports having gradually reached their former level, these rules and regulations were discarded. In the spring of 1921 only a very few were left, such as regulations and maximum prices for bread and sugar and certain regulations of the beer and spirit industries. To ensure thorough economy in the production of spirits the respective concerns formed a combine. These measures for controlling prices were taken after consultation with the different trades.

Taxation and Public Finance.—The former basis of taxation of landed property in Denmark was the assessment of *Harkhorn* which was based on the quality of the land and had remained unaltered since 1844. For other property there was a variety of taxes of old standing. A law of 1903 introduced a new general assessment of all estates and property. Land rent was based on periodical valuations ("selling value"). A general income and property tax of a progressive per-cent. rate increasing in amount almost every year, and at the same time made more progressive, was introduced in the same year. The indirect taxes are the customs duties and the inland taxation of industry and trade. The tariff of 1863 was moderate but became heavier than was intended because of falling prices; and in 1908 it was revised, all necessities of life, raw materials and agricultural produce being relieved of duty; protective duties were made small and duties on tobacco and spirits relatively high. Objects of taxation giving the best return are beer, spirits, tobacco and sugar. In the financial year 1913-4 the revenues of the Danish State amounted to 124 million kroner. Of these 101 million kr. were raised by taxation, 28 million kr. by direct and 73 million kr. by indirect taxes. The war occasioned an increase of taxation, and at the same time a change from indirect to direct taxation was effected. The State revenues of the financial year 1919-20 were 601 million kr., of which 575 million were from taxes, 347 million kr. direct, 248 million kr. indirect. Yet the main part, 235 million kr., of the direct taxes were extraordinary taxes. The national debt was in 1914 361 million kr. and in 1920 925 million kroner. The debt of all the municipalities was in 1914 375 million kr. and in 1920 750 million kroner. It must, however, be borne in mind that the value of State and municipal assets had proportionately increased.

Money and Banking.—Before 1908 the right of the National Bank to issue bank-notes was based on the same system as the Bank of England, but in that year the quota system was adopted. By legislation of 1915 the bank is required to be in possession of gold to the amount of one-third of the notes in circulation, and for the

remaining part there must be security in assets easily cashed according to special rules. The amount circulating in notes in 1900 was about 100, and just before the war about 150 million kroner. In the middle of 1917 it was 365 million kr., in 1919 511 million kroner. In 1914 the duty of the National Bank to redeem its notes with gold was temporarily suspended and it had not been reimposed in 1921. The other big banks of Denmark are the Danske Landmandsbank, with a stock capital of 100 million kr. and a balance at the end of 1919 of 1,421 million kr. (of which more than one-quarter is put under the ample heading: "Sundry Debtors"); Privatbanken, stock capital 60 million, balance 504 million; Københavns Handelsbank, 50 million, balance 672 million; Københavns Diskonto og Revisionsbank, 48 million, balance 452 million kroner. In connexion with the farming import and export organizations a cooperative banking institute, the Danske Andelsbank, was established in 1914 with a guarantee fund of 11 million kr. paid in. There are also several smaller banks, but in recent years many provincial banks have been absorbed by the big banks.

**Prices.**—According to an average calculation wholesale prices— if the immediately pre-war index figure is put at 100—rose to 249 by July 1917. The upward tendency continued until the maximum was reached in Nov. 1920 with the figure 430. The general tendency afterwards was downwards, the figure for April 1920 being 270. The advance in the retail prices of necessities of life is illustrated by figures calculated on the basis of household budgets for families belonging to the working classes. The expenses of such a family just before the war being put at 100, the index figure rose constantly till it reached 265 at the close of 1920. The value of the Danish krone was very unsteady during the war compared to other values. In the post-war years the £ and \$ rates declined—the minimum was reached in Nov. 1918, £ equalling 13 kr. and \$1, 2.80 kroner. The exchanges were afterwards reversed, the maximum being reached in Sept. 1920, when £ equaled 25.68 kr. and \$1, 7.40 kroner. In April 1921 £ equaled about 21.50 kr. and \$1 about 5.50 kroner.

**Finance.**—About 1910 the yearly revenue of the Danish State was estimated on the basis of the assessment for income tax, at about 1,200,000,000 kroner. In the war period this showed a constant increase, 1917-8 disclosing a yearly revenue of 2,600 million kr. and 1918-20 of over 3,300 million kroner. Thus since the war the yearly revenue has been multiplied by 2½, i.e. in almost the same ratio as the retail price index. The incidence of incomes is more equal in Denmark than in many other states, though here as elsewhere the contrast between rich and poor was to some degree sharpened during the war. In 1915 about 70% of the adult population (married women excepted) had incomes of less than 1,000 kr., making together some 30% of the total income; about 29% had incomes between 1,000 and 10,000 kr., 48% of the total incomes; and nearly 1% had incomes of more than 10,000 kr., about 22% of the total incomes. While in 1908 three-quarters of the adult population (again with the exception of married women) had incomes of less than 1,000 kr., in 1918 only half the population were below that amount. The national wealth before the war was estimated at 10 milliards, and in 1921 had probably doubled (the assessed property had risen from 5,000 to 10,000 million kroner). While in 1908 about 92% of the adults possessed property of less than 10,000 kr., the corresponding figure for 1918 was only 87%.

The value of the shares represented on the stock exchange was in 1912 about 800 million kr., the quotation of the same shares was in 1918 about 3,000 million, in 1919 2,000 million and in 1921 probably 2,000 million. The difference of 2,000 million kr., forwards and again backwards, may represent individual gains and losses, to some extent made and suffered by the same persons. (F. G.-T.)

**Labour.**—In the seventies and 'eighties of the 19th century, the era of moderate industrial development, an impetus was given to the trade-union movement closely connected with the Social Democratic party. Both employers and employed are very strongly organized, chiefly under the two main organizations, the Combined Trade Unions and Danish Employers' Organization. The trade unions included in 1919 nearly 350,000 members, 277,000 belonging to the Combined Trade Unions. In 1910 Denmark was foremost in the movement, 51% of the workmen employed in industry, commerce and communications being organized. Since then the movement has made rapid progress. In most industries nearly all the workmen were in 1921 members of the organizations. There has also been a considerable inflow of agricultural labourers. The usual basis of classification of the unions is trades, not industries.

Besides the divisions for the different towns there are factory clubs and shop stewards; in some places a system by which chosen representatives exercise an influence over the general conditions of work has grown up in connexion with these clubs. In the summer of 1920 syndicalistic tendencies manifested themselves rather strongly, but in 1921 the movement largely died away.

The Employers' Organization, dating in its present centralized shape from 1898, exercises considerable authority over its members, by whom about 200,000 workmen are employed. After an extensive lockout in 1890 the two main organizations made the so-called "September agreement," deciding, for instance, that a positive majority is required for the declaration of strikes and lockouts, which must, moreover, be notified according to certain rules, and that all differences on the question of the interpretation of existing

contracts and agreements must be referred to arbitration. After a conflict in 1910, on the proposition of the parties concerned, a law was passed adopting the system of conciliation in disputes and the establishment of a special court to decide questions of law. The average number of days lost in labour conflicts over a series of years was only one day a year for each workman, but in the unsettled state of the labour market in 1919-21 much higher figures were reached, chiefly owing to strikes in the Copenhagen building trades and among sailors and navvies. During the transport strikes of 1920 the activities of "Samfundshjælpen," a voluntary civic organization for carrying out indispensable work left undone by the strikes, were of considerable importance.

The Employers' Organization attached great importance to the simultaneous expiration of the labour agreements of the different trades. This often resulted in joint negotiations for the renewal of agreements, in most cases accompanied by threats of extensive stoppages of work, which had, however, until 1921 always been averted at the last moment. In later years yearly agreements were made, adopting an automatic regulation of wages according to the price index of the Statistical Department from the middle of the period. A smaller part of the wages of State employees was also calculated according to this price index. Even before the war Danish industry suffered considerably from unemployment, which amounted to 10% in the period 1909-13. After the close of the war, conditions became still more complicated owing to the after-effects of the blockade and the critical state of affairs generally.

Wages in Denmark were somewhat high compared with other European countries. The average weekly wages for skilled labourers were: in 1897 20 kr.; 1905 25 kr.; and 1920 120 kr.; for unskilled labourers 16, 20 and 100 kroner. During the war wages rose continually, at first slower than prices, later somewhat faster, but in the spring of 1921 a general though not very important reduction of wages took place. Before the war about 20% or 25% of the workmen in industry were paid by the job. The wages of agricultural labourers were: in 1910 700 kr.; 1915 800 kr.; 1918 1,400 kr.; and in 1920—partly owing to the increasing organization—1,800 kroner. The position of Denmark in the matter of working hours has, as was the case in the matter of wages, been something between that of England and the rest of Europe. The average working hour of industry were in 1872 11¼; since then they have gradually decreased. Accordingly, when the eight-hour day was adopted on Jan. 1 1909 by voluntary agreement between the chief organizations, this was a step of comparatively small importance. Denmark joined the international agreement about the eight-hour day, but in May 1921 no law concerning this question has been passed.

At the close of the 19th century a general interest in social questions was greatly awakened. The year 1873 brought the first factory legislation, and in the beginning of the 'nineties came the general decisive acceptance of insurance relief legislation. The leading principle is voluntary State-aided insurance against illness and unemployment, and for the rest public relief, apart from accident insurance, which, as elsewhere, is paid by the employers. The poor law of 1891 not only regulates pauper administration proper but also lays down certain rules, which have been repeatedly extended, for State or parochial relief, directed through the ordinary pauper administration but without the usual unpleasant consequences to the recipients. Such aid is given in cases of a number of chronic diseases, insanity, epilepsy, tuberculosis, blindness and to deaf-and-dumb persons. Medical and obstetric aid is also given and extended aid to members of benefit clubs. Since 1907 every parish has had besides the poor-rates, a relief fund—*Uthjælpekasse*, with a board of its own, intended to administer relief in cases of urgent need. This fund has, however, in many cases become merely a more respectable form of pauper administration. By the Old-Age Pensions Act passed in 1891, Denmark took the lead in the question of providing for the aged. Certain conditions are laid down as to the need and worthiness of the recipients, and it is especially stipulated that persons who have for five years previously received parish relief are excluded. The age limit is 60 years. The amount of the pension, which is decided upon the merits of each separate case, should suffice for sustenance of life, and medical aid in case of illness is included. In 1919 the number of recipients was 74,000 and the expenditure amounted to 34 million kr., State and parishes contributing each one-half. Denmark has several voluntary benefit clubs, mostly locally organized, but State-aided and under State control, in accordance with the Benefit Club Act of 1892, amended in 1921. Notwithstanding the voluntary system 70% of the working classes and a large number of others of similar standing are members, the total number amounting to two hundred thousand. As children of the members below the age of 15 years are also entitled to the benefits, the full number makes about three-fifths of the population. The chief benefits are hospital treatment, medical aid and subsistence money not exceeding 6 kr. a day. The State aid is 3 kr. per member and one-quarter of the chief expenditure. A considerable economic advantage to the benefit clubs is the very low charges made by the public hospitals for treatment of the members. The clubs recognized by the State have limited self-government under control of the State inspector of benefit clubs.

By three decrees of 1921 persons suffering from chronic diseases were admitted to the sickness insurances without any extra charges;

an insurance against disablement, forming an obligatory supplement to the voluntary sickness insurance, was established; and special rules were laid down concerning "poor-relief without the effects of poor-relief," to be paid to a considerable part of the uninsured disabled. The first Accident Insurance Act relating to a number of dangerous industries and based on the principle of employers' liability was passed in 1898, and after some gradual improvements a general comprehensive Act was passed in 1916. It is the duty of the employer to have all persons employed insured in the private accident companies. For compensation a sum of money not exceeding 24,000 kr. is given. Special rates are paid to the sons of widows. As early as 1907 an Unemployment Insurance Act was passed. The unemployment funds are voluntary and are practically identified with the trade unions. During the critical years 1917-9 the ordinary State aid was very considerably raised; and large sums were distributed according to rules which were less strict than usual.

In 1918 the entire contribution of the State to social insurances and the various forms of relief was, apart from sums arising out of special war-time legislation, 17 million kroner. The municipalities contributed 39 million kr., while the contribution of the members of sickness and unemployment insurance societies was 12 million kr., and the employers paid for the accident insurance 6 million kr., altogether about 74 million kroner. While the social insurance system proper is generally considered satisfactory—though in the recent difficult years the administration of the unemployment funds has been the object of criticism—strong claims were advanced for a modification of the old-age pensions system, which should establish a right to fixed rates, and also for a thorough reorganization of the lower branches of social relief (the pauper administration and relief funds), the administration of which had become complicated and unpractical owing to their gradual development. Danish factory legislation is, notwithstanding its inauguration by the conservative but very far-seeing Ludvig Bramsen (in the 'nineties)—father of the Danish Employers' Liability Act—rather radical and thoroughgoing, and very ably and effectively administered. On the other hand, Denmark has no Wages Board or Minimum Wage system.

(F. Z.)

**Political History.**—After the Cabinet of J. C. Christensen—the formation of which in 1905 had led to a split in the ranks of its supporters, the Left Reform party separating from the Radical Left party—had been forced by the Alberti catastrophe to retire, a new Cabinet was formed by Niels Neergaard, a distinguished historian, as leader of the Moderate Left, with the support of the Moderate and Left Reform party (Oct. 12 1908). The problem of defence became the most prominent under this Cabinet, as the defence commission, which had been working since 1902, now reported. The members of the commission had not reached unanimity. The Socialists proposed disarmament; the Radicals wished the military to be replaced by a naval and police guard; while the Right proposed a material increase of military forces. The Government and its supporters in the *Rigsdag* were divided on the question of Copenhagen's land defences, and only after great confusion—new elections had not brought clearness—did the old leader of the Left, Count Holstein-Ledreborg, who had been away from active politics for years, succeed, as premier of a new Cabinet, in carrying through a new arrangement. The army and navy were enlarged; Copenhagen's naval defences were strengthened; and the land defences were to be dismantled not later than March 31 1922.

No party had a majority in the *Folkething*, and the Holstein Ministry was forced to retire in favour of a new Cabinet, formed by the Radicals with C. Th. Zahle, a barrister, as premier. This Cabinet could depend on support from the Socialists in the *Rigsdag*, though without thus acquiring a majority in either of the Houses. Under these conditions the Government announced its intention of postponing the introduction of the Radical programme. With the support of the Right it was able to secure a majority in favour of a proposal to prosecute the two ex-ministers, J. C. Christensen and Sigurd Berg, before the State Parliamentary Court, the *Rigsret*, for neglect of their ministerial duties in regard to Alberti (Mr. Christensen was acquitted and Mr. Berg sentenced to a fine). As the Government proposed a democratic amendment of the constitution and met with opposition, the *Folkething* was dissolved, and at the elections of May 20 1910 the Left, which was still divided on the defence problem, won half the seats. The two moderate Left groups now united into one party, the Left, and one of the old Moderate leaders, Klaus Bernsen, a former teacher in the peasant high schools, formed the new Cabinet on July 5 1910.

King Frederick VIII. died on May 14 1912 and was succeeded on the throne by his son, Christian X.

With the support of the Radicals and the Socialists the Government again raised the constitution problem in 1912, but because of opposition in the Upper House (*Landsting*), where the Right controlled about one-half of the seats, no solution had been reached when the ordinary elections were held in May 1913. At these the Radical and Socialist parties gained control of 63 out of the 114 seats in the *Folkething*; Zahle formed the new Radical Cabinet. The constitution problem immediately became prominent, and the constitutional parties decided to let nothing divide them because of the importance of the issue; under these conditions the Socialists voted for the budget for the first time. The Right raised the most decided opposition against this united democracy; powerless in the *Folkething*, they undertook, by a policy of obstruction in the *Landsting*, to check the further development of the case. As an answer to this the Government dissolved the *Landsting*. The election results were: 29 supporters and 25 opponents of the constitutional amendment. Of the 12 members nominated by the Crown 9 were on the side of democracy, hence the Government was certain of a solid majority.

The outbreak of the war temporarily hindered the final solution of the constitution problem. It was with great anxiety for the future of their country that the Danish people experienced the fateful days of Aug. 1914. On Aug. 1 the *Rigsdag* passed a number of laws which the extraordinary conditions made necessary. The mobilization of the emergency army, numbering in all about 70,000 men, began on the same day. All political parties agreed in maintaining the neutrality of Denmark. An attack by Germany was especially feared. A difficult situation arose on Aug. 5 in consequence of an inquiry from Germany as to whether the Danish Government intended to block Danish waters with mines, an inquiry which could only mean that if Denmark refused Germany would lay the mines. The Government was uncertain as to Denmark's responsibility as a neutral Power, and only after great hesitation was it decided to lay the mines. With this Germany was satisfied, and England sanctioned the action in view of Denmark's precarious position.

It became apparent that the war situation might have serious effects upon Denmark's economic life. Accordingly the *Rigsdag* on Aug. 7 authorized the Home Secretary to regulate prices and to confiscate all goods on giving full compensation. A Price-Regulating Committee was established to advise the minister. Further the Secretary of Justice was given power to prohibit exports. The Government exercised these powers several times during the following months to secure the supply of food grains and for other purposes. As in military affairs, the Government adhered to the policy of keeping the warring nations always-informed of the measures adopted, and in this way succeeded in establishing, with both sides, confidence in Denmark's desire for real neutrality, and an understanding of the importance of maintaining effective industries. This in time resulted in fixed agreements with Germany and England as to exports.

When the first anxiety was allayed the constitution problem was again taken up. As the opposition of the Right was declining, a result was reached without great difficulty and June 5 1915 the King signed the new constitution. This introduced equal suffrage in the elections for both Houses, men and women being entitled to vote under identical conditions; the voting age was fixed at 35 years for the *Landsting* and was lowered successively from 30 to 25 years for the *Folkething*. Of the 140 members of the *Folkething*, 95 are elected in individual districts, 27 in greater Copenhagen according to proportional representation, and 23 supplementary seats are divided among the parties that have received too few representatives at the other polls in proportion to their number of votes. The *Landsting* has 72 members, of which 54 are indirectly and proportionally elected in the larger districts, while 18 are elected by the retiring *Landsting* according to the same principles. In the case of a constitutional amendment a referendum must take place, and 45% of the eligible voters must vote for it to give it validity. The constitution came into force on April 21 1918.



! Other important legislative Acts of the first years of the war, which were passed unanimously, were the Reform of the Administration of Justice (April 11 1916), which separated the administrative and judicial systems, and introduced oral proceedings and publicity—with trial by jury in criminal and political cases—and the Accident Insurance law (July 6 1916), which made it the duty of all employers to insure their employees. The privileged suffrage in elections to the *Amtsråd* (county councils) was abolished with the consent of all parties.

In the late summer of 1916 the comparative quiet which had marked political life since 1914 was succeeded by a bitter struggle. The cause was the announcement by the Government that it had concluded a treaty with the United States ceding the Danish West Indies to that country for \$25,000,000. Both in the *Rigsdag*, whose ratification was essential, and outside strong feeling was aroused against the sale. The Left proposed a postponement till after the war or, if an immediate decision was necessary, the holding of fresh elections under the new constitution. The only solution of the crisis seemed to be new elections, but the King implored the party leaders to avoid such a situation, which would be a danger to the country. The result was a compromise: the Cabinet was supplemented by representatives of each of the political parties (Th. Stanning, the Socialist member, being the first member of the working classes to become a minister), and the sale of the islands was to be decided by the *Rigsdag* after a plebiscite of the people. At the polls (Dec. 14 1916) 283,670 votes were cast in favour and 158,157 against, and shortly afterwards the *Rigsdag* ratified the cession.

A contest of like character, but not nearly so far-reaching or bitter, arose in connexion with the rearrangement of the relation of Iceland to Denmark. With increasing force, Iceland demanded political independence and integrity. Despite the opposition of the Conservatives, the support of the other three parties sufficed to pass an Act of Union (Nov. 1918), in which Denmark acknowledged the independence of Iceland. The King is joint ruler of both countries and Denmark directs Iceland's foreign policy. The Act of Union is valid till 1940.

From 1917 onwards the unrestricted submarine warfare, combined with the stricter measures of the Entente, caused increasing difficulties in the economic life of Denmark. The Government, for whose economic policy the Home Secretary, Ove Rode, was primarily responsible, made further efforts, by means of maximum prices, export prohibition, and also by the rationing of certain articles, to create tolerable conditions for the people. It sought to mitigate the effects of the increase in prices by an extensive policy of relief; both the State and the communes rendered direct aid to those without means; public officials received increased pay until their salaries had undergone a thorough revision; and the unemployed, whose number rose to 70,000 in the winter of 1918-9, were given extra support. Through an increase of the succession, income and personal property taxes, and the introduction among others of a tax on exchange business, the Government tried to cover these and the greatly increased military expenses. In the five years of the war 1914-9, the expenditures of the Government were 156, 185, 251, 369, 616 million kr. respectively (in all 1,577 million kr.), and the total revenue for all five years 1,343 million kroner. The deficit was covered by loans. While the indirect taxes 1913-4 amounted to 55% and the direct to 28% of the total revenue, the figures of 1918-9 were 21% and 62% respectively. A radical anti-militaristic Government had from 1914-9 spent more than 500 million kr. on defence—more than all the Conservative war ministers together from 1865-1901.

After the spring of 1918 the elections could no longer be postponed. At the elections for the *Folkething*, when women voted for the first time (68% voted to the men's 84%), 72 supporters of the Government were elected, 39 Socialists and 33 Radicals, receiving 203,000 and 196,000 votes respectively; and 68 opponents, 45 Left and 23 Conservatives, receiving 273,000 and 168,000 votes respectively. The *Landsting* was constituted as follows: 17 Conservatives, 26 Left, 13 Radicals and 15 Socialists.

At the time of the Armistice the old problems were viewed differently and new questions arose. The troops were quickly demobilized, the special defence works were razed, and on March 17 1920 a law was passed abolishing the land defence and artillery of Copenhagen. In 1919 the special military administration of justice had ceased. The Government's economic policy, which had caused some dissatisfaction, but as a whole had been supported by all parties, became the object of very strong criticism, as the Opposition thought it time to abrogate the war-time legislation in this respect. Instead of improving, the economic conditions became worse: small exports, the falling value of the Danish krone both at home and abroad, and numerous strikes, partly caused by the syndicalistic agitation, characterized the industrial and economic situation until near the close of 1920.

The Allied victory affected Denmark chiefly through the prospects of a reunion with the Danish part of Slesvig. On the same day—Oct. 23 1918—as the deputy of North Slesvig, H. P. Hansen-Nørremølle, raised the demand of a reunion with the mother country in the German *Reichstag*, the Danish *Rigsdag* unanimously passed a resolution "that no other change in Slesvig's present position than an adjustment according to the principles of nationality would harmonize with the wishes, feelings and interests of the Danish people." With reference to this and statements made by the leaders of the Danish population in North Slesvig, the Danish Government communicated its wishes to the Allies (Nov. 28 1918), so that, when the Peace Conference in Feb. 1919 reached the discussion of the Slesvig problem, a united Danish North Slesvig delegation was sent to Paris to present the Danish point of view: a plebiscite *en bloc* in North Slesvig (Zone 1), a community ballot in Central Slesvig and Flensburg (Zone 2), and voting rights to all those who were born in the voting districts. The Peace Treaty was presented to Germany on May 7. The fact that it contained a provision for a plebiscite in South Slesvig (Zone 3), and gave voting rights to natives of the districts without consideration of their present place of residence, caused considerable excitement in Denmark. This departure from the wishes of the Government and the *Rigsdag* was due to the influence of a small group of the Danish people who wished the Slesvig question to be solved from a legal and historic point of view. Representations to the Peace Conference by the Danish Government were successful in getting the article providing for a plebiscite in Zone 3 omitted from the Treaty.

On the coming into force of the Peace Treaty on Jan. 10 1920, an international commission, containing among others the ambassadors of England and France, Sir Charles Marling and M. Paul Claudel, took charge of the plebiscite district. The plebiscite in Zone 1 on Feb. 20 gave 75,431 (75%) votes for Denmark and 25,329 (25%) for Germany; even the doubtful Tønder Amt had a majority for Denmark of 59%. On March 14 Zone 2 gave 48,148 (79%) German and 13,029 (21%) Danish votes.

While the plebiscite results in Zone 1 satisfied Danish expectations, this was not the case with the results in Zone 2. In the last years before the war the Danish element had here been yielding in the national struggle, but there seemed to be plain evidence of a change of feeling, especially in Flensburg, during the agitation before the plebiscite. The disappointment over the result was great. The *Zahle* Ministry had for months been the object of the most vehement attacks, because of its cool attitude towards the national propaganda in Central Slesvig, and the assailants made it responsible for the poor result of the plebiscite. In certain circles it was still hoped to prevent the final union of Central Slesvig with Germany by the so-called "Internationalization" of Zone 2. A storm of indignation at the national attitude of the Government in connexion with its economic policy began in the weeks after the plebiscite. When the Government refused to order new elections, with reference to the necessity for a new electoral law, the King dismissed it. A Cabinet of non-politicians, formed by Liebe March 30 1920, took the responsibility for the King's action, which was regarded by the supporters of the dismissed Cabinet as unconstitutional, and had caused the threat of a general strike from the Socialists. During this "Easter crisis" Denmark was not, but may have looked as if it were, on

the verge of a revolution. The mediation of the city council of Copenhagen and others conciliated the Crown and the Socialists, and on April 5 a new Ministry, consisting chiefly of State officials, was appointed to formulate an electoral law and to order new elections. The new law was based on proportional representation in the county districts (*Amtskredse*), and the supplementary seats system was retained in a slightly altered form. At the *Folkething* elections (April 25 1920) the Left received 351,000 votes (49 seats), the Conservatives 201,000 (28), "Erhvervsparti" (trades party) 29,000 (4), against the Socialists' 300,000 (42), and the Radicals' 122,000 (17). Niels Neergaard formed the new Left Cabinet on May 5.

On July 7 1920 the international commission handed over the executive power in Zone I, awarded to Denmark by the Allies, to the Danish Government. After the constitutional amendments necessitated by this expansion had been adopted, the *Folkething* elections were held on Sept. 21 1920. In these the people of North Slesvig took part, and the voting age was 25 years for the first time. The results were 417,000 votes cast for the Left (52 seats), 390,000 Socialists (48), 212,000 Conservatives (27), 147,000 Radicals (18), 27,000 "Erhvervsparti" (3), and 7,000 for the German candidates (1). The Left maintained the leadership, and the Neergaard Ministry continued.

The problems relating to the constitution and to defence, which formerly were of the greatest consequence, had during later years been thrown into the shade by social problems, and the political parties were in 1920-1 developing in an increasing degree as representing economical interests, and as attached to certain classes: thus the Left was supported by the farmers, the Radicals essentially by the small holders, the Socialists by the industrial labourers, and the Conservatives by the capitalists and the middle classes in the cities.

See also: Erik Arup, *Rids af Danmarks Historie* (1921); Fr. Nørgaard, *Danmark fra 1864 til Genforeningen med Sønderjylland* (1920); Alex. Thorsø, *Grundrids af den danske Rigsdags Historie 1866-1925* (1920).

**Literature.**—Between 1910 and 1921 Danish literature lost by death several of its representatives already famous—Karl Gjellerup (1857-1919), Herman Bang (1857-1912), Peter Nansen (1861-1918), Vilhelm Bergsøe (1835-1911), Sophus Bauditz (1850-1915), Troels Frederik Lund (1840-1921), Edvard Holm (1833-1915) and A. Fredericia (1849-1912). In 1917 Henrik Pontoppidan (b. 1857), the novelist, was awarded the Nobel prize.

While the older generation was still productive, either on the old lines or, as in the case of Karl Gjellerup, taking up new themes (classical, ancient Gothic, Indian), a good many young authors came to the front. Niels Møller (b. 1859) and Ludvig Holstein (b. 1864), in their few but elaborate poems, represented the scepticism and dark views of the 'eighties; Vigo Stuckenberg (1863-1905) and his friend Sophus Clausen belong essentially to the aesthetic renaissance; and partially this may also be said of Sophus Michaelis (b. 1863) and Edvard Blaumüller (1851-1911), although they have some features in common with the younger generation. All these were mostly lyric poets, but Stuckenberg and Michaelis had also written powerful novels.

The foremost younger lyrical poets were Valdemar Rørdam (b. 1872; *Selected Poems*, 1918) and Helge Rode (b. 1870). Thor Lange (1851-1915), as well as Rørdam and Møller, made many excellent translations of English and foreign poems. To the same school belong L. C. Nielsen (b. 1871; *Cantatas, Children's Songs*); Kai Hoffmann (b. 1874; *The Town and the Sea*, 1902; *Selected Poems*, 1916); Olaf Hansen (b. 1870; *Selected Poems*, 1918; *Translations from Icelandic*); Thøger Larsen (b. 1875; *Selected Poems*, 1917); Axel Juel (b. 1833). Of a more pessimistic and satirical type is Harald Bergstedt (b. 1877; *Jack and Elsie*, 1916—"a modern Adam Homo").

Powerful novels were produced by Harald Kilde (1878-1918) and Johannes Buchholtz (b. 1882). Ever since the latter half of the 'nineties the provincial note had been strong in Danish literature, as represented by writers emanating from the farm-houses and workshops. Foremost stands Jakob Knudsen (1858-1917), son of a parson, and for a time himself a clergyman but

descending from and in the closest contact with Jutland peasants, a novelist of extraordinary power, but without artistic refinement. From Jutland also came Jeppe Aakjaer (b. 1866), a peasant's son and a peasant himself; his masterpieces are short stories and lyrical poems, but he has also written novels and historical essays. Johannes V. Jensen (b. 1873, son of a Jutland veterinary surgeon) has shown himself a master in his treatment of the Danish language (*Prehistoric Novels*, 1909-19, translations from Frank Norris and Whitman). From Fünen there is the novelist Morten Korch; from Zealand, Thorkild Gravlund (b. 1879), partly novelist, partly folklorist; Knud Hjortø (b. 1869), a prolific novelist; and from Bornholm, Martin Andersen Nexo (b. 1869), who had, given pathetic pictures of the proletarians' lives. H. Bergstedt has manifested a satirical vein of some consideration.

The outstanding name in archaeology has been Sophus Müller (b. 1846, director of the National Museum till 1921). Ludvig Wimmer (1839-1920) was supreme as a runologist (*Danish Runic Monuments*, 1895-1908). Folklore has had eminent representatives in H. F. Feilberg (b. 1831; *Jutlandic Dictionary, Danish Peasant Life*), in Evald Fang Kristensen (b. 1843) and in Axel Olrik (1864-1917; *Heroic Legends of Denmark*; in English 1919). Celebrated linguists are Kristoffer Nyrop (b. 1858; *Grammaire historique de la langue française i-iv.*), and Otto Jespersen (b. 1860; *Progress in Language*, 1894; *Growth and Structure of the English Language*, 1905; *Modern English Grammar*, 1909-14). The domestic culture of Scandinavia about 1600 was depicted by Troels Frederik Lund (*Daily Life in Scandinavia*, i-xiv.), while Danish and foreign literatures were treated by Vilhelm Andersen (b. 1864) and Valdemar Vedel (b. 1865).

See Vilh. Andersen and Carl S. Petersen, *Illustreret dansk Literaturhistorie* (1916 seq.); Dahl and Engelstoft, *Dansk biografisk Haandlexikon* (1918 seq.). (M. K.)

**DENTISTRY** (see 8.50\*).—The progress of dentistry in the decade 1910-20 was more rapid and more radical than in any previous period. The cause of this progress was the general advancement in knowledge due to the accumulation of data arising from scientific investigation and the application of the knowledge thus acquired to the prevention and treatment of disease. Until comparatively recent times the extent to which abnormal mouth and teeth conditions are responsible for derangements of health was imperfectly understood. The pioneer studies of W. D. Miller, of Berlin, especially as reported (1891) in a series of communications entitled *The Human Mouth as a Focus of Infection*, first called attention to the fact that the oral cavity is the habitat and breeding ground for a large group of micro-organisms, many of them possessing pathogenic character which under conditions of lowered resistance invade other parts of the organism and become the direct exciters of bodily disease. Miller also showed that the mouth is the common portal of entry for most of the disease-producing organisms that infect the human body, and further demonstrated that certain mouth bacteria, when injected into the circulation of a test animal, could pass through the blood stream or lymphatic system and establish metastatic foci of inflammatory action at points and in organs remote from the seat of inoculation. These early findings were afterwards confirmed by other investigators, more particularly by Sir Kenneth Goadby, of London. Recognition of the significance and far-reaching importance of the principles underlying these results of scientific research was only gradually accorded by the general body of the dental profession, and then merely as interesting facts without direct utility in dental practice.

In several communications on septic dentistry, notably in an address delivered in 1910 at the opening exercises of the annual session of the Medical school of McGill University, Montreal, Sir William Hunter, physician and lecturer to the Charing Cross hospital, London, criticised badly conceived and unskillfully executed dental restorative operations, especially in crown and bridge work and the treatment of pulpless teeth, which were performed without regard to surgical asepsis. In this connexion Hunter brought to bear clinical evidence to prove the soundness of his contention that operations so performed leave septic foci

\* These figures indicate the volume and page number of the previous article

that cause septicaemic conditions, as well as infections in remote parts of the body. Hunter's revelation impressed at once the dental and medical professions and his criticisms immediately bore fruit. The general use of the X-ray as a means for study of the apical region of tooth roots, the development and application of specialized bacteriological technique for determining in pulpless teeth the identity and character of the exciters of disease action and similarly those responsible for inflammatory lesions of the retentive structures of the teeth (commonly designated as *pyorrhea alveolaris*), all stimulated by the realization of the profound clinical importance of mouth infections as related to bodily health, quickly followed the communications of Hunter.

The total effect of this evidence, both clinical and scientific, upon the development of dentistry has been little short of revolutionary. From time immemorial it has been believed from empirical observation that an unclean and infected mouth cavity is a source of bodily ill health, and much direct evidence of a clinical character had accumulated to strengthen that belief, but the evidence now at hand has affirmatively established the facts by scientific demonstration. Until this development of knowledge concerning the systemic relationships of disorders of the teeth and their related structures and their bearing upon the bodily health, the major feature of dental interest, and that upon which the attention of the profession was concentrated, had been the development and perfection of manipulative procedure in restorative operations. The ingenuity expended and the excellence of the results attained had become the outstanding characteristics of dental practice; and the restoration by prosthetic or operative means of the masticatory mechanism damaged by partial or total loss of teeth had been its dominating ideal. There is now an enforced recognition in the professional as well as in the lay mind of the importance of the welfare of the tissues and organs of the mouth. In the dental profession the consequent changes of technical procedure and objectives have been fundamental. The ideal of mechanical perfection in the methods and appliances by which the dental surgeon restores the patient's power to masticate has come to be regarded as a remedial measure subservient to the larger ideal of normal mouth health.

**Oral Hygiene in Schools.**—One of the principal factors which extended and popularized this knowledge is the oral hygiene movement, an effort to demonstrate practically the fact that school children, relieved of the disabilities arising from infected mouths and diseased teeth which handicap normal development, will show improved physical and mental efficiency. What is known as the Cambridge experiment, inaugurated in 1907 by the late George Cunningham, of Cambridge, England, was perhaps the earliest practical test. The analogous work of Dr. Ernst Jessen, of Strassburg, resulted in the introduction of oral hygiene into the public schools of a number of towns in Germany. In the United States the oral hygiene movement took practical form in the test of its utility in the Marion school of Cleveland, O., in 1910, and in 1919 there was completed under conditions yielding accurate figures, a five years' test of applied mouth hygiene in the public schools of Bridgeport, under the direction of Dr. A. C. Fones. In this test 20,000 children of the first five school grades were under observation and treatment. The average number of carious cavities was found to be over 7% per child; 30% claimed that they brushed their teeth occasionally; 60% frankly stated that they did not use a tooth brush and 10% were found to have fistulas on the gums, showing outlets from abscesses from the roots of decayed teeth. Systematic application of oral hygiene, the intelligent and systematic use of the tooth brush, and the elimination of accretions, dental decay and suppurative conditions achieved striking improvement in general health and mental efficiency. With respect to general health the statistics of the Bridgeport board of health show that the most common fatal diseases among children in that locality were diphtheria, measles, and scarlet fever. The decrease in deaths from these sources after the introduction of oral hygiene in the public schools is shown by the following table, the figures for 1914 showing conditions before the test:—

	1914.	1918.
Diphtheria . . . . .	36.6%	18.7%
Measles . . . . .	20.0	4.1
Scarlet Fever . . . . .	14.1	0.5

The improvement in mental efficiency is shown by the reduction in the percentage of retarded children. A retarded child as defined by the Bridgeport school board is one who is not less than two years older than the normal age for the school grade to which it should belong. The percentage of retarded children before and after the

introduction of mouth hygiene in the Bridgeport schools is shown in the following table:—

Grade.	Percentage of Retarded Children.		
	Sept. 1912.	Nov. 1918.	Drop in retardation.
I.	16.5%	8.1%	51.0%
II.	37.0	15.3	58.0
III.	53.0	24.7	53.0
IV.	59.5	31.7	47.0
V.	61.0	33.1	45.0
VI.	54.0	30.4	44.0
VII.	39.0	19.3	50.0
VIII.	27.0	12.5	54.0
Average.	40.0	20.1	50.0

Since retardation represents inability of the child to continue to advance with his class, it necessitates repetition of his grade work, and therefore becomes an economic question of serious importance to the ratepayer. The cost of reeducation in Bridgeport in 1912 was 42% of the entire budget, and for 1918 only 17%. Among the 20,000 children under observation in the schools of Bridgeport, it was found that 98% had various forms and degrees of malocclusion of the dentures, a condition now generally recognized as being associated with a symmetrical development of the bones of the face and the brain case. Many children with malocclusion owing to the arrested development of the facial and cranial bones suffer from impeded nasal respiration, and moreover develop adenoids and tonsillar hypertrophy, leading to infection with its systemic sequelae and the interferences with bodily nutrition incident to insufficient oxidation of the blood. Orthodontic treatment for the correction of malocclusion in children has come to be regarded as a therapeutic and prophylactic measure having an important health relation rather than as a mere cosmetic procedure for the relief of deformity. The foregoing facts furnish convincing evidence of the desirability of making oral hygiene available to children of school age as a feature of dental public health service on economic as well as humanitarian grounds and on the broader ground of national efficiency.

**Work in Armies and Navies.**—Analogous considerations resulted in the organization in various countries of army and navy dental service of the nation. From small beginnings upon a contract basis the U.S. army and navy Dental Corps rose to an allotment by law of one dental surgeon for each 1,000 of the army personnel, and before the close of the World War provision had been made to double that allotment and to supply adequate equipment for field and hospital service. Instead of contract service the corps was placed upon a commissioned basis with pay and allowances identical with those of the Medical Corps and rank within the corps through all grades up to and inclusive of colonel. After 1918 full provision was made by the U.S. Government for the dental care of its enlisted men and of those demobilized from service suffering from dental defects or disabilities since demobilization. This latter activity is assigned to the dental division of the public health service. Accurate statistics as to the development of army and navy dental service in forces of other nations are not yet available, but the proportion of dental surgeons to army personnel in 1917, as given by officials of the British Dental Association (see "Man Power and the Army Dental Service," *British Dental Journal*, Feb. 15 1918), for some forces was:—Canadian Expeditionary Force, one per 1,000 men; New Zealand Expeditionary Force, one per 2,500 men; Australian Expeditionary Force, one per 2,600 men. Satisfactory figures for the German army dental service are not obtainable, but according to Dr. Ernst Jessen, head of the dental work in Strassburg, quoted in the *German Dental Review*, there were 810 dental surgeons active in the field in 1915. France, during the World War, had at least 1,500 army dentists working in various parts of the lines as fixed units, in addition to the dental ambulances. The French army dental service furnished a striking example of the practical importance of army dental service in that during the latter part of the war, when the man power of France was seriously depleted, over 250,000 effectives were mustered into the French service as the result of efforts instituted by Dr. Georges Villain, of Paris, by which that number of men who had been previously rejected because of loss of teeth, but were otherwise physically sound, were subsequently fitted with artificial dentures and sent to the fighting line.

The British dental service in the World War was inadequate, owing to the limited number of qualified dental surgeons available and the unfortunate fact that of the 1,050 to 1,100 serving in the army and navy in various capacities about 300 were enlisted as combatants, and of those latter 50 were killed. (See *Report of Parliamentary Committee on the Relation of Military Service to Man Power*, D. F. Pennefather, Chairman.) Great Britain created by Royal Warrant, issued Jan. 4 1921, a military dental service, the Army Dental Corps, which is administered by the Director General, Army Medical Service. The Army Dental Corps is a joint service for the army and R.A.F., and is on a commission basis with rank through the grades inclusive of lieutenant and lieutenant-colonel. Experience during the war clearly demonstrated to all the belligerent nations the importance of dental service as a

status of mouth sanitation and the practical utility of the latter in maintaining the physical efficiency of the fighting personnel, with the result that definite and active work has been undertaken to extend these health benefits to civilian populations.

Undoubtedly the most notable example of comprehensive planning for the national extension of dentistry and oral hygiene as a factor of the public health service is that proposed in the *Interim Report on the Future Provision of Medical and Allied Services*, made to the British Ministry of Health by the Consultative Council on Medical and Allied Services, May 1920. This report recognizes oral hygiene and dental services as factors of the health and as proper subjects for control and development by the State. Oral hygiene campaigns made much more than the correction of dental defects and oral infection due to neglect of the tooth brush; its aim is prophylactic as well as corrective. Corrective procedures such as the filling of cavities of decay, treatment of diseased roots, extraction of useless teeth, correction of irregularities in their position and prosthetic restoration of lost teeth or parts of teeth, merely arrest the progress of disease and mechanically restore damage already done. The entire energies and skill of the whole dental profession are totally inadequate to cope with more than a small fraction of the corrective work needed. To establish the habit of personal care of the mouth in school children is a field of activity that has developed the specially trained dental nurse or hygienist as an adjunct to dental service, whose calling is now legalized in the principal states of the United States. The work of the dental nurse is limited to the surface treatment of teeth, in the removal of deposits and accretions thereon, the training of school children in the systematic use of the tooth brush and their education in the importance of mouth cleanliness. In addition to the physical benefits resulting from oral hygiene among school children, the mental and social improvement in general is also a factor. A child who has learned to use the tooth brush exhibits increased self-respect, greater attention to bodily and mental cleanliness, closer compliance with school regulations and an awakened interest in attendance and studies. The close connection between oral hygiene and better citizenship is no longer debatable, and the present trend is toward making dental and oral hygiene service in all civilized countries a public health measure.

The many head, face and jaw wounds during the World War created a new field for oral surgery and surgical prosthesis. For the successful treatment of these cases it became evident that surgical measures alone were insufficient, as the loss of tissue from gunshot wounds of the head and face, as well as the unsightly scars resulting from extensive lesions when surgically treated, left the patient in many instances with repulsive deformities. The resources of surgery and dentistry were called into cooperation. Plastic surgery, involving the transplantation of the soft tissues and of bone to supply missing parts, was developed to a degree previously unknown. The rebuilding of the face, including reconstruction of the nose, lips, cheeks, the orbicular region, etc., was accomplished with a perfection in many cases almost miraculous. In the work the aid of dental prosthetic technique was often necessary. The large and increasing number of casualties of the head, face and jaws resulting from trench warfare quickly developed the need for hospitals and specialized equipment devoted entirely to the treatment of this class of wounds. Of these centres of specialized surgical activity the foremost in importance and extent was Queen's hospital, Sidcup, Kent, England, a unit under British administration with sections for British, Canadian, New Zealand and Australian forces manned by personnel from the respective forces. Cooperation between the medical and dental staffs of the sections was organized with most satisfactory results. The American Ambulance hospital of Paris at Neuilly-sur-Seine, subsequently taken over as American Red Cross hospital No. 1, was an analogous centre of specialized head, face and jaw surgery in which similar cooperation was again successful. These experiences furnished convincing evidence of the need by each profession of a more intimate acquaintance with the work of the other. This need is recognized in the practice of adding a professional dental service to hospital staffs.

A general quickening of scientific research has followed. Bacteriological and histological investigation of dental and oral pathology by numerous investigators has not only added greatly to knowledge in this field, but brought about great improvement in dental and oral surgical technique. Notable progress has been made in the study of dental and oral infections and of physical irritations of nerve terminals in and about the teeth, in their relation to mental disorders and reflex neuroses, that cause disturbances of the special sense organs as well as spastic disorders of a local or general character. Attention has been directed to the endocrine relationships of the teeth and oral tissues, especially as to the probable connexion between the activities of the ductless gland system and the reactions of the salivary secretion, as well as to variations in the calcified structures of the teeth and their susceptibility or immunity to caries. Corresponding changes in the objectives as well as in the character, the content and extent of dental education have taken place in harmony with these developments. Practical teaching has tended toward a closer approximation to the fundamental ideals and methods of general medicine in so far as they represent the principles common to the whole science and art of healing. While the most conspicuous progress in dentistry during the decade 1910-20 has

been in the direction of its vital and hygienic relations, its technical and engineering features have shown a similar development. Until this period the construction of artificial dentures for the prosthetic restoration of lost teeth was almost wholly an empirical procedure depending on the judgment, manual skill and good taste of the operator. Scientific studies of the engineering principles underlying the mechanism of the human masticatory function, initiated about 1800 by W. G. A. Bonwill, of Philadelphia, and since prosecuted by his numerous followers, have brought the knowledge of masticatory movements and of the relations of the teeth and their moral surfaces thereto to a state of completeness that enables the prosthetist by the aid of mechanical articulating devices to reproduce in the artificial denture a mechanism with possibilities approximating, both functionally and artistically, those of natural dentures.

The work of Alfred Gysi, of Zurich, constitutes the most advanced achievement in this field. In close relation to the progress is the coordinate progress made in the artistic reproduction in porcelain of nature's forms and colouring, brought about mainly by the studies of J. L. Williams, of New York, and N. S. Essig, of Philadelphia.

In 1913 Charles H. Mayo, the distinguished surgeon of Rochester, Minn., expressed the opinion that the next great step in medical progress in the line of preventive medicine should come from the dental profession. A review of the progress since made would seem to indicate a reasonable prospect of the fulfilment of that prophecy. (E. C. K.)

**DEPEW, OMAUNCEY MITCHELL** (1834- ), American lawyer and politician (see 8.56), failed of reelection as U.S. senator on the expiration of his term in 1911. In 1914 he favoured the repeal of the Panama Canal Tolls bill. He assailed pacifism and after the sinking of the "Lusitania" (1915) urged a strong stand against Germany. In 1928 he presented to Peekskill, N.Y., a bronze statue of himself, which was erected in Depew Park, a plot of land purchased from the Indians in the 17th century by an ancestor, François du Puy. In 1919 he added much adjoining land to this park.

He is the author of *Some Views on the Threshold of Fourscore* (1914), including speeches delivered 1912-14, and *Speeches and Literary Contributions at Fourscore and Four* (1918), articles and speeches composed 1916-18).

**DERBY, EDWARD GEORGE VILLIERS STANLEY, 17TH EARL OF** (1865- ), English statesman (see 8.59), was in Jan. 1915 created a Knight of the Garter. In Oct. 1915 he became director of recruiting for the army, and as such was responsible for a new scheme for a final effort on behalf of voluntary service. A large number of recruits were obtained by Lord Derby's scheme, but as the numbers did not equal expectations the Military Service bill was introduced and carried in Jan. 1916. In Feb. 1916 Lord Derby became chairman of the naval and military air service joint committee, but resigned in April, becoming Under-Secretary of War in July. On the formation of Mr. Lloyd George's Government in Dec. 1916, he became Secretary of War, and in April 1918 was appointed British ambassador to France. He retired from the latter office in Nov. 1920.

**DEROULEDE, PAUL** (1846-1924), French author and politician (see 8.74), died at Mont-Boron, near Nice, Jan. 30 1924. In 1910 he had published a collection of his patriotic speeches, and a volume *La Ligue des Patriotes* containing further extracts from them appeared two years after his death.

**DESCHANEL, PAUL EUGÈNE LOUIS** (1856- ), French statesman (see 8.91). During his absence from the presidential chair in the Chamber of Deputies after 1902, Deschanel carved out for himself a position of some political importance on the Committee of Foreign Affairs. He was president of this important committee when the Franco-German treaty of 1911, confirming the settlement of the Agadir incident, came before Parliament. He was reelected deputy in 1910, and on May 23 1912 he was chosen to succeed M. Brisson in the presidency of the Chamber of Deputies. He was maintained in this office by subsequent ballots in 1913 and 1914. His presidency of the Chamber was marked by much oratory of a literary nature, and by considerable dexterity in the treatment of the rowdy elements of the extreme Right and the extreme Left. He aimed at being the impartial Liberal Republican. During the World War he played a great part as the national orator. There were, indeed, few occasions of sorrow or of thanksgiving which his eloquence did not either lighten or intensify. He delivered orations more frequently than he made speeches. Whether it was to hold Gen-

man infamy up to universal execration, to sing the splendours of the dead of France, to pay a glowing tribute to an ally's achievements, or to console the widow and the orphan and spur on the living fighter, he always had at his command the delicate, if somewhat artificial, style of speech of the great Latins, which combined both the structure of the artist and the feeling of a man. Speech did not give to him a sufficient outlet for his literary gifts. He was prolific as a writer in reviews such as the *Revue de Paris*, the *Revue Bleue*, *Revue Hebdomadaire* and the *Nouvelle Revue*. His books number *Figures de Femmes*, *Figures littéraires* (both 1889), and a tribute to his political godfather Gambetta. His talents as a litterateur were recognized by his election to the French Academy on May 18 1899. He married on Feb. 13 1901 Mlle. Germaine Brice, and had three children.

It was a secret to none that M. Deschanel, throughout his long political life, nurtured one great ambition—the desire to become President of the republic. When in Jan. 1920 M. Poincaré's term of office came to an end, it was with some genuine reluctance that Clemenceau allowed himself to be put forward as a candidate in opposition to Deschanel. That reluctance was justified by results. In the preliminary party ballot Clemenceau was beaten, and withdrew his candidature. Deschanel was elected President of the republic by the National Assembly on Jan. 17 1920 by an overwhelming majority. His term of office opened brilliantly, but his health was unable to stand the strain of office. In May 1920, while on an official journey to Montargis, he fell unobserved from the presidential train, and though he found his way to a signalman's box, and suffered no worse consequences than a nervous breakdown, he was temporarily incapacitated. His condition subsequently became such that on Sept. 20 1920 he was obliged to resign his office, and to leave Rambouillet, where he had sought the quiet necessary for the restoration of his health. He then went into a private nursing home at Reuil where he sufficiently recovered to be able to stand successfully for the Senate in the elections at the beginning of 1921; though he no longer took an active part in public affairs. (G. A.)

**D'ESPÉREY, LOUIS FRANCHET** (1856— ), French marshal, was born at Mostaganem, in Algeria, on May 25 1856, and was commissioned from St. Cyr to the infantry in 1876. As a junior officer he saw much service in N. Africa and Tongking. For a time he was aide-de-camp to Freycinet, then Minister of War and premier. He served also in the expedition to N. China in 1900, after which he commanded an infantry regiment at home. He became general of brigade in 1908 and general of division in 1912. For a time he commanded the troops in Morocco, but in 1913 he was appointed to the I Corps at Lille. He commanded this corps in the V. Army during the battle of the Frontiers, and at Charlevoi had the ungrateful task of protecting the right of Laurzeac's army during its deployment on the Sambre; brought up at last on to the battlefield to deliver a decisive counter-stroke, he was at the moment of attack withdrawn again to protect the right rear of the army, the force which had released him having failed to keep the line of the Meuse. In the difficulties of the retreat which followed it was the I Corps and its commander which formed, according to Laurzeac's own testimony, the soundest element of the V. Army, and when that general was relieved of his command on the eve of the battle of the Marne, Franchet d'Espérey was his obvious successor.

Gen. Franchet d'Espérey commanded the V. Army during the battle of the Marne and the advance to the Aisne, and continued in command till the end of March 1916, when he was appointed to the eastern group of armies, in succession to Gen. Dubail. After holding this office for some eight months, he passed to the more active command of the northern group of armies, of which he was in charge throughout the campaign of 1917. In May 1918 he went to Salonika as commander-in-chief of the Allied armies in that theatre. His predecessor, Gen. Guillaumat, had worked out the main features of a general offensive on the Salonika front, and continued, in close cooperation with him, to support the claims and needs of such an offensive in the councils of the Allied High Command at Paris. Men and material were sent out in adequate numbers, and

though Franchet d'Espérey, even with Guillaumat's assistance, was only able to obtain the decisive authorization to attack a few days before the scheduled date, his energy was equal to the task of hastening on the last stages of preparation and on Sept. 13 an offensive was launched that carried all before it. Bulgaria surrendered, and the pursuit was pushed with hardly a check into and through Old Serbia. After the final victory he remained in charge of the Allied forces in European Turkey and Balkan occupied territory, with headquarters in Constantinople. He was created a marshal of France early in 1921.

**DETAILLE, JEAN BAPTISTE EDOUARD** (1848-1912), French painter (see 8.110), died in Paris Dec. 24 1912.

**DETROIT** (see 8.113).—Commencing with the recovery from the industrial depression of 1907-8, the city of Detroit entered upon a period of growth almost without precedent among large cities. The area of the city in 1907 was 35.65 sq. m., but by the end of 1918 had increased to 83.58 sq. m. With reference to a portion of this area a peculiar condition existed. The villages of Hamtramck and Highland Park were originally outside territory into which the population and business of Detroit overflowed. By annexations in 1916 and 1917 their outer boundaries were brought two miles within the city limits, but they still retained their separate municipal administrations. Together they covered 4.83 square miles. The pop. of the city as estimated from the Water Board enumeration of families was in 1907 about 300,000. In 1910 the U.S. census record was 465,766. The census of 1920 gave a total of 1,088,853 within the city limits, distributed as follows: under Detroit municipal administration 993,739; village of Hamtramck 48,615; City of Highland Park 46,499. A canvass made late in 1920 by the various city agencies for Americanization indicated that about 70% of the population was either of foreign birth or foreign parentage. Poles, Germans and Russians represented the largest numbers, though there were large accessions from south-eastern Europe. In a single automobile plant there were 34 nationalities represented. A canvass of the public schools taken in Dec. 1920 showed 35% of the pupils of American-born parentage, 30.5% being *whites* and 4.5% coloured. In 45% of children of foreign-born parents Polish ranked first and Russian next. In the three years ending with 1920 a large amount of work was done by the Board of Commerce, the Board of Education, and leading manufacturers in teaching the English language and the elements of citizenship through public night schools and factory schools.

**Manufacturing**.—The extraordinary growth of the city was mainly a consequence of the expansion of its manufacturing industries. In 1904 the city was 12th in rank among the industrial centres of the country, with \$91,038,000 in manufacturing capital, 60,150 industrial employees, and a product valued at \$128,247,000. Five years later it was 6th in place, with a capital of \$210,000,000, 103,287 employees and product of \$252,092,000. In 1914 it was 4th, with a capital of \$405,000,000, 147,188 employees and product valued at \$569,000,000. In 1918 the number of employees had increased to 319,000 and the value of the product was estimated at \$1,450,000,000. In the first half of 1920 industrial activity was at its height, and although there was a decline in the latter part of the year, the total value was estimated at a slight increase over the previous year. By far the most important of the manufacturing industries was the making of automobile parts and accessories and assembling of motor cars. The business began in Detroit in 1899, but was not classed by the Census Bureau as a separate industry till 1904, when it had \$3,447,000 capital, employed 2,191 workers and had a product valued at \$6,240,000. In 1909 the capital employed in the industry had increased to \$28,928,000, the number of persons employed in office and factory 17,437, the number of cars produced 45,560 and the value of the product \$59,536,000. The next year there was a great expansion of the industry, both through the organization of new companies and additions to old plants. With the exception of a slight set-back in 1914, the growth was continuous till the latter part of 1920. At its peak of production in that year there were 25 companies assembling motor cars and 140 whose sole or principal business was the making of automobile parts and accessories. Together they employed about 155,000 persons and put out 1,250,000 cars valued at over \$1,000,000,000. The Ford Motor Co. alone had a maximum of 55,000 men on its pay rolls; Dodge Bros. 23,000; and the Packard Co. 17,000. The distribution of these products was world-wide, the portion set apart for export in 1920 amounting to \$152,000,000. During the decade ending in 1920 there were numer-

ous other changes in Detroit's manufacturing industries. Freight-car building, which was the largest of all up to 1908, has been almost entirely discontinued. The carriage and furniture factories were for the most part changed to the making of automobile accessories, and clothing manufacture diminished. Meantime some of the metal industries increased enormously. The city in 1920 was either first or near the front in the following lines: aluminium castings, brass products, computing machines, druggists' preparations, soda ash and kindred alkalis, stoves and varnishes.

**Transportation.**—For the accommodation of the increasing traffic caused by this industrial expansion there were great enlargements by the transportation lines. The Michigan Central tunnelled Detroit river and built an immense new passenger station and office building. That road and the Grand Trunk and the Pere Marquette made great additions to their freight yards, stations and sidings, and the outer belt line was extended. The Pennsylvania lines were extended from Toledo to Detroit, with a belt line of their own round a portion of the city, and ample freight and passenger facilities. The Detroit, Toledo and Ironton, which was suffering for lack of funds and equipment, was purchased by the Henry Ford interests, with great improvement in its facilities for service on a coal road. In lake freight transportation 1916 was the maximum year. The number of passages by vessels through the Detroit river that year was 37,852, net registered tonnage 76,677,264, actual freight tonnage 100,607,279, estimated value of freight \$1,069,617,157. There was also in 1919 and 1920 an astonishing development in motor-truck service. There were in 1920 about 20 established lines reaching out from the city in all directions, and covering distances as great as 50 m. or more. At the April election in 1920 by a vote of 89,285 to 51,093 the people approved of a plan for municipal construction and operation of street railways. It was intended for the present to supplement, but ultimately to absorb, the privately owned system. A short section was opened Feb. 1, 1921.

**Miscellaneous.**—The manufacturing and population growth was accompanied by similar expansion in other lines. For example: assessed valuation, 1910, \$377,335,980; 1920, \$1,699,749,580; city tax levy, 1910, \$6,837,686; 1920, \$25,085,359; bank capital and surplus, 1910, \$19,130,000; 1920, \$28,313,500; bank deposits, 1910, \$10,183,995; 1920, \$59,944,735; bank clearings, 1910, \$910,835,005; 1920, \$6,109,313,803; building permits, 1910, 5,498, to cost \$17,225,945; 1920, 19,412, to cost \$77,373,365; post-office receipts, 1910, \$2,133,647; 1920, \$6,031,442; internal revenue receipts, 1910, \$6,725,941; 1920, \$30,184,392; imports, 1910, fiscal year, \$13,763,200; 1920, \$91,160,552; exports, 1910, \$82,143,633; 1920, \$39,844,490. Detroit's allotment of the four Liberty loans and the Victory loan was \$233,977,172. The subscriptions actually made amounted to \$299,794,150, from 785,176 subscribers. During 1917 and 1918 contracts for munitions and army supplies to the amount of about \$900,000,000 were taken in Detroit. Of these nearly \$300,000,000 worth were cancelled after the Armistice.

**Administration.**—Under a charter adopted by popular vote June 25, 1918, the methods of municipal government were materially changed. In place of a Board of Education of one member from each ward, there was a Board of seven members, elected two or three at a time on a general ticket and holding office for six years. The old Board of Estimates, consisting of two members from each ward and five at large, was abolished, leaving appropriations and bond issues to be determined by the mayor and common council. The mayor's final judgment was conclusive upon all appropriation items, unless reversed by a vote of seven out of the nine aldermen. The old common council of two aldermen from each ward was displaced by a council of nine members all elected at one time on a general ticket. The mayor, city clerk and city treasurer were elected, but all other administrative officers and commissions were appointed by the mayor, without reference to the council, and were subject to dismissal by him without trial. Nominations, two for each office to be filled, were made at non-partisan primaries. Blanks for voting were also non-partisan, and the time of election was separated from that of the state and national contests. By special legislative enactment the police and recorders' courts were combined in one with seven judges, holding office for four years and having jurisdiction of all criminal and ordinance cases. The judges were all chosen at one time on a non-partisan ticket. (W. Sr.)

**DE VALERA, EDWARD (EAMONN)** (1882— ), Irish republican leader, was born October 24, 1882, in New York City, N. Y. His father, Vivian de Valera, was a Spaniard; his mother, whose maiden name was Kate Coll, came from near Bruce, Co. Limerick. He spent his childhood and boyhood among his mother's people, and was educated first at the national school and later at the Christian Brothers' school, Charleville. He then went to Blackrock College, Co. Dublin, where he gained a reputation both as a student and an athlete. Here he worked at Latin, Greek, French and English literature, and at his favourite subject, mathematics. He won a middle grade exhibition in 1899, and in 1900 one in the senior grade. Entering the Royal University in 1901, he won the next year a second class mathematical

scholarship. He went as teacher to Rockwell College, and while there graduated with a pass B.A. degree in mathematical science, in 1904, and proceeded to the B.Sc. degree in 1914. In 1909 he passed the examination for the diploma in education (teaching). For a time he worked at a thesis on questions for his M.A. degree, but he never presented it. He also attended lectures in mathematics at Trinity College, Dublin, where he unsuccessfully competed for a scholarship. Returning to Dublin, he taught mathematics, Latin, and French in the principal Roman Catholic colleges, including the old University College, St. Stephen's Green; Belvedere; Clonliffe; Dominican College; Eccles Street; Loreto College, St. Stephen's Green; and Caryfort Training College for teachers. He examined in mathematics for the Irish Intermediate Board of Education in 1912 and following years. He unsuccessfully attempted to become an inspector of national schools. He was very popular with his pupils. He also rapidly acquired a knowledge of Irish (Gaelic), and in 1914 he was able to read difficult bardic Irish poetry. He took charge of the Irish Summer College at Tawin founded by Casement.

On the foundation of the Irish Volunteers in 1913, he threw himself heart and soul into the new organization. Sinn Fein had turned to the use of violence in 1909, and to this organization De Valera belonged, though he assumed no leading share in it till the Easter rebellion of 1916. When Casement was captured he countersigned the order of Thomas MacDonagh on April 23, cancelling the inspection and manoeuvres ordered for that day. When, nevertheless, the rebellion broke out De Valera was in the outer circle of Dublin held by the rebels, which ranged from Ringsend to Ballsbridge. He commanded the insurgents holding Boland's bakery, which was valuable in two ways: it assured the rebels a supply of foodstuffs, and it offered a commanding position for rifle fire. Though there was heavy firing day and night in this district, there were not many casualties, as there was much cover for both sides. The real leaders of the rebellion were P. H. Pearse and J. Connolly. When an order from the former reached De Valera commanding him to surrender, he at first refused to believe that it was genuine. When he satisfied himself on Sunday, April 30, he submitted and surrendered with the hundred men of his garrison. He was sentenced to death, but the sentence was commuted to penal servitude for life, and he was committed to Lewes prison, but was released in the general amnesty of June 15, 1917. No conditions had been attached to the release of the prisoners, and De Valera himself openly ascribed this action of the Government not to generosity, but to fear. As the only surviving leader of the rebellion, he found at once that he had achieved importance in the eyes of the majority of the Roman Catholic Irish, who had meanwhile swung round violently in the direction of Sinn Fein. When the ex-prisoners left the boat at Kingstown De Valera marched at their head, and his entry into Dublin was a triumphal progress. His triumph was increased in the same month by his election for East Clare by a large majority, his opponent being P. Lynch, who had been the crown prosecutor and now stood as a Nationalist. The importance of this election rivalled that of the famous Clare election of 1828, when O'Connell stood. De Valera's sweeping victory gave an immense impetus to the Sinn Fein cause.

From this time until his re-arrest in the spring of the following year De Valera was the heart and soul of the Sinn Fein movement. A facile writer and speaker, both in English and Gaelic, he was a master of the type of unmeasured eloquence that appeals to the Irish temper, which is impatient of compromise. In Dublin, on the day after his election for Clare, while in the hall of the convention the representatives of the N. and S. were engaged in seeking a formula of union, in the street outside De Valera was telling a cheering crowd that "if Ulster barred the way, Ulster must be coerced." A similar violence characterized all his speeches. The Sinn Fein convention of Oct. 26-27, 1917 elected him "President of the Irish Republic."

In the agitation, in the early part of 1918, against "conscription" De Valera took a leading part. But in May the discovery by the Government of another plot for a rising, to be combined with a German invasion, led to his re-arrest together



with some 150 other prominent Sinn Feiners. He was imprisoned at Lincoln, in England, but on Feb. 3 1919 he, with two other Irish prisoners, escaped and, ultimately, made his way to the United States. Here, working with the same restless energy as in Ireland, he was successful for a time in enlisting a large amount of public sympathy for the Sinn Fein cause, especially in Irish and German-American circles. He was received as "President" by the civic authorities of New York (under Mayor Hylan's Tammany administration) and in other cities where the Irish vote predominated, presented with their "freedom," and otherwise honoured. His attempt, however, to persuade the party conventions, assembled to nominate candidates for the presidency, into making the independence of Ireland a plank in their programmes, completely failed, and the Irish question was not mentioned in the programme of either party. With the election of Mr. Harding to the presidency, it became clear that De Valera's efforts to involve the United States in a quarrel with Great Britain about Ireland had broken down, and in the spring of 1921 he returned to Ireland, where in June and July negotiations were opened with him by the Government with a view to an Irish settlement (*see IRELAND: History*).

In 1910 De Valera was married to Miss Sinead Ni Fhlannagain, one of the most popular teachers and earnest workers of the Ard Craobh and Colimille branches and of the Leinster College.

**DEVENTER, SIR JACOB LOUIS VAN** (1874- ), S. African general, was born in the Orange Free State in 1874. A colonel on the permanent staff of the S. African Defence Force, Van Deventer served in the German S.-W. Africa campaign, 1914-5, where he had a distinguished record in active service. His real gifts as a general, however, were not fully appreciated till he went to German E. Africa, to fight in Gen. Smuts's campaign against the Germans there. So well did he acquit himself in that field that when Gen. Hoskins, who had succeeded Gen. Smuts in the chief command, ceased to hold that post in 1917, Van Deventer was appointed commander-in-chief of the Empire Military Forces in E. Africa. He was then a major-general, and was given the temporary rank of lieutenant-general on becoming commander-in-chief. Shortly afterwards he was created K.C.B., in recognition of distinguished services in the field. As commander-in-chief he showed the same qualities which had secured for him this high promotion and it was under his auspices that the campaign was brought to a successful end. Van Deventer left E. Africa at the end of 1918, sending a message of thanks to the administrator of Southern Rhodesia, in which he expressed his sincere thanks for the "unfailing co-operation of the Rhodesian troops, British and African, in the campaign."

**DE VILLIERS, JOHN HENRY DE VILLIERS, BARON** (1842-1914), first Chief Justice of the Union of South Africa, was born at Paarl, Cape Colony, in June 1842. Descended from the Huguenots who settled in that part of the Cape, he was educated at the South African College, Cape Town, and went to Utrecht and Berlin universities. In 1865 he was called to the bar by the Inner Temple, and in the same year returned to South Africa and began practice as an advocate of the Supreme Court of Cape Colony. His success was immediate. Entering Cape politics in 1866, he was elected a member of the House of Assembly, became attorney-general of the Colony in 1872, and two years later was appointed Chief Justice of the Cape. In that high office he speedily confounded critics of his appointment. The Roman-Dutch law of the Colony, admirable in its logic and symmetry, was ill-fitted to the complications of modern conditions, and it was the life-work of de Villiers to adapt it to these needs. This he did with a conspicuous success which has secured for his name a place high on the roll of those great judges who have done the work of British civilization in many parts of the world. De Villiers was knighted in 1880, was created a K.C.M.G. a year later, and in 1910 was raised to the peerage on his assumption of the post of Chief Justice of the newly formed Union of South Africa. He died Sept. 2 1914.

In the work of moulding the instrument of union he had borne a great if not a decisive part. Throughout his career he had taken a constant interest in the politics of Cape Colony and of

South Africa—an interest which had never degenerated into partisanship, which had throughout been inspired by a true and enlightened patriotism, which had never lacked the touch of courageous plain speech at the many moments of crisis through which his country had passed. Universal recognition of these outstanding qualities made the appointment of de Villiers as president of the National Convention inevitable, though it must be said that, as the work of the Convention drew towards completion, there were murmurs—and not without justification—that long years on the bench had done something to affect his natural aptitude for presiding over the deliberations of such a body. These criticisms, however well justified, should not detract from the greatness of his achievement, both as a judge and as a figure in the tortured public life of South Africa during the hazardous years of his career. As a judge he touched genius. Acute, unbiased, learned in the crabbled texts of Roman-Dutch law, he added to these gifts the art of keeping steadily in mind the practical needs of the life of his country as affected by his judgments. Equity rather than precedent was his mentor. With the bar his relations were those of a wise and revered adviser. During repeated visits to Great Britain he shared with known distinction in the work of the Judicial Committee of the Privy Council, and the value of his assistance to that body was recognized more than once in public by his colleagues.

**DEVONPORT, HUDSON EWBANKE KEARLEY, 1ST VISC** (1856- ), English politician and man of business, was born at Uxbridge Sept. 1 1856, and educated at Cranleigh school. He entered the firm of Kearnley & Tonge, tea merchants and shippers, of London and Calcutta, subsequently becoming senior partner. In 1892 he entered Parliament as Liberal member for Devonport, and from 1905 to 1909 was parliamentary secretary to the Board of Trade. In 1908 he was created a baronet, and in 1909 was elected chairman of the Port of London Authority, being prominent in this capacity during the strike of transport workers and lightermen at the London docks in 1912. In 1910 he was raised to the peerage. He was appointed first Food Controller in 1916, and in 1917 became secretary to the Sugar Commission, but had to retire owing to ill-health. The same year he was created a viscount.

**DEWAR, SIR JAMES** (1842- ), British chemist and physicist (*see 8.137*), published (with G. D. Liveing) *Collected Papers on Spectroscopy* (1915). In 1916 he received the Copley medal of the Royal Society, and the Franklin medal of the Franklin Institute of Philadelphia in 1919.

**DEWEY, GEORGE** (1837-1917), American naval officer (*see 8.139*), died in Washington Jan. 16 1917, and three days later was buried in the Arlington National Cemetery. By special provision Admiral Dewey was never retired but continued in active service up to his death, for the last seven years being president of the General Board of the navy. To the last he continued to urge the building of large battleships, citing their superiority in the battle of Jutland in the World War. He published his *Autobiography* in 1913.

**DIAZ, ARMANDO** (1861- ), Italian general, was born in Naples Dec. 6 1861. He entered the artillery and served in that branch and in various staff appointments, until his promotion to major, when he transferred to the infantry. He served in the Italo-Turkish War in command of a regiment and was wounded at Zanzur in Sept. 1912. In 1914 he was promoted to major-general, and, after commanding the Slesha Brigade for a short time, was transferred to the general staff. On Italy's entry into the World War he was attached to the supreme command as chief of the operations department. He held this post till June 1916, when he was promoted lieutenant-general and took command of the 49th Division, which in Nov. of that year distinguished itself by the capture of Volkovnjak, an important position on the northern rim of the Carso. He visited the French front in Jan. and Feb. 1917, and in June he was given special promotion and confirmed in command of the XXIII. Corps, which he had held temporarily from its formation two months previously. Under his direction in the following Aug. this corps won a considerable success between Korite and Selo, on the Carso.

In Nov. 1917, after the Caporetto disaster, Diaz succeeded Cadorna as chief of the general staff. He was confronted with a very serious situation, but he brought to bear upon it all the useful understanding and resolution. Under his direction the battle front was successfully reconstituted, and the work of reorganizing the Italian army was carried out. At the instigation, and under the close personal supervision, of Diaz much was done to improve conditions for the soldiers at the front and for their families at home. Under his command the double attack of Borevich and Conrad was broken up at the battle of the Piave (June 1918) and the armies of the Dual Monarchy were destroyed by the battle of Vittorio Veneto (Oct.—Nov. 1918). For his services Diaz received the collar of the *Annunziata*, the highest Italian order. In Nov. 1919 he was nominated army general and retired from his position as chief of staff, and later, upon the reorganization of the army and Ministry of War, he was appointed vice-president of the Army Council. He also became a Senator and in 1919 he received the freedom of the City of London.

As a division and corps commander Diaz displayed high military qualities. His position as chief of the general staff was rendered delicate by the fact that the British and French divisions which were sent to Italy after Caporetto were not at first placed directly under his command, and his personal qualities were specially adapted to render collaboration easy. Diaz has been criticized for excess of caution in delaying his final attack upon the Austro-Hungarian armies. It is possible, though by no means certain, that he might have attacked with success sooner. But an earlier victory might very well have been less complete, and anything less than complete victory would not have served the cause of Italy or of the Allies.

**DIAZ, PORFIRIO** (1830—1915), president of the republic of Mexico (see 8.172), died in Paris July 2 1915. In April 1910 he was elected president for the eighth time, but as the result of widespread opposition to what was regarded as a prolonged dictatorship, a revolution broke out the following Nov., headed by Francisco I. Madero. Because of his age the President could not head his army personally, and in May 1911 was forced to resign. With his family he went to Spain, and thereafter until his death lived in various European capitals.

**DICEY, EDWARD** (1832—1912), English writer (see 8.178), died in London July 7 1912.

**DIERX, LÉON** (1838—1912), French poet (see 8.210), died in Paris June 11 1912. His *Poésies Posthumes* appeared in 1913.

**DIESEL, RUDOLF** (1857—1913), German engineer, was the inventor of the Diesel oil-engine (see INTERNAL COMBUSTION ENGINES), the possibilities of which, however, had hardly been realized till after his untimely death. He fell overboard the Antwerp-Harwich mail steamer on Sept. 30 1913, and was drowned.

**DIGGLE, JOHN WILLIAM** (1847—1920), English divine, was born at Strawberry Hill, Pendleton, March 2 1847. He was educated at Manchester grammar school and Merton College, Oxford, where he graduated in 1870, being ordained in 1871. After many years of energetic work in various parishes he was in 1892 made examining-chaplain to the Bishop of Carlisle, Dr. Bardsley. Four years later he became archdeacon of Westmorland and canon residentiary of Carlisle. In 1902 he became rector of St. Martin's, Birmingham, in 1903 was made archdeacon of Birmingham, and in 1905 became Bishop of Carlisle, where his energy and industry brought him a great reputation. He died at Rose Castle, Carlisle, March 24 1920.

**DIGGLE, JOSEPH ROBERT** (1849—1917), English educationist, was born in Lancs. May 12 1849. He was educated at Manchester grammar school and Wadham College, Oxford. He took orders, but resolved later to devote himself to public work. In 1879 he was elected for the Marylebone division to the London school board, on which he remained until 1897, being chairman from 1885 till 1894. Diggle was an active member of many committees for the betterment of the conditions of the working classes, and published *Pleas for Better Administration upon the London School Board* (1881 and 1885). He died at Oxford Jan. 16 1917.

**DILKE, SIR CHARLES WENTWORTH, 2ND BART.** (1843—1911), English statesman (see 8.271), died in London Jan. 26 1911, and was succeeded by his son, **CHARLES WENTWORTH DILKE** (1874—1918), who died in London Dec. 7 1918. The baronetcy went to Sir Fisher Wentworth Dilke (b. 1877), a cousin of the 3rd Bart.

**DILLON, JOHN** (1851— ). Irish Nationalist politician (see 8.273). The Irish members endeavoured unsuccessfully to censure the conduct of the Speaker in regard to the suspension of Mr. Dillon on March 20 1902. He was prominent that year in Parliament in his attacks on the Government for the revival of the Crimes Act, and in the following year he helped forward Mr. Wyndham's Land Purchase Act. For several subsequent years he played a comparatively subordinate part both in Ireland and in Parliament; but in 1909 he appeared as a leading apologist of cattle-driving, telling the House of Commons that the grazing system in Ireland had become an abomination. He aided the parliamentary progress of the Home Rule bill mainly by a judicious silence. In the years before the World War he had been very critical both of the increased naval preparations, which he said were the result of a bogus naval scare, and of Sir Edward Grey's policy in Egypt and Morocco. But he followed his leader, Mr. Redmond, in urging Ireland to take her share in the war against Germany, and spoke at the meeting in the Dublin Mansion House on Sept. 25 1914, when the platform was occupied by the Lord Mayor, the Lord Lieutenant, Mr. Asquith (Prime Minister), the Chief Secretary, and Mr. Redmond. In Parliament, however, he showed himself opposed to compulsory service and the setting up of a Munitions department; and after the Dublin rebellion he said he was proud of the rebels, accused the Government of washing out the word Nationalist in a sea of blood, and declared that Sir John Maxwell's system of military rule had done more to spread disaffection in Ireland than all the organizers of Sinn Féin. He did not show himself very sympathetic or hopeful in regard to the various suggestions of Mr. Lloyd George for settling the Irish question. In July 1918, as Mr. Redmond's successor in the leadership of his party, he brought forward a motion that the Irish policy of the Government was inconsistent with the principles for which the Allies were carrying on the war, advised calling in President Wilson to settle the question, and bitterly denounced what he called the outrageous coercive system in force in Ireland. But the violence of his language did not save him from the vengeance of Sinn Féin who now dominated that country; he, along with almost the whole of the Constitutional Nationalist party, lost his seat at the general election of Dec. 1918.

**DINANT, Belgium** (see 8.274).—The town was almost completely destroyed at the beginning of the World War by German forces invading Belgium, who here endeavoured to force the passage of the Meuse, the left bank of which was held by the French. On Aug. 23 1914, the Germans rushed the town, and, on the pretext that the civil population had fired on them, they set fire to the town and shot numbers of the inhabitants *en masse*. In all 665 persons, or about one-tenth of the total pop., were massacred, among them being 71 women and 30 infants, many of the latter only a few weeks old. Of 1,653 houses only about 600 remained. A minute inquiry into the charge, held subsequently, completely established the innocence of the inhabitants. The rebuilding of the town was being actively pursued in 1921.

**DINES, WILLIAM HENRY** (1855— ), English meteorologist, was born in 1855, the son of G. Dines, also a meteorologist. He was educated at Woodcote House school, Windlesham, and afterwards entered Corpus Christi College, Cambridge, where he obtained a first-class in the mathematical tripos in 1881. He afterwards carried out some investigations for the Royal Meteorological Society on the subject of wind forces, and in connexion with this work designed the Dines pressure-tube anemometer. In 1901 he commenced researches into the problems of the upper air, and designed or perfected several instruments for use with kites, as well as a form of the Hargreaves box-kite, which proved of great value. In 1905 he was appointed by the Meteorological Office director of experiments in connexion with the investigation

of the upper air, and in 1907 designed a meteorograph for use with balloons. He also produced, in conjunction with Dr. Napier Shaw, the microbarograph and a recording mercury barometer, as well as various other instruments. From 1901 to 1902 he was president of the Royal Meteorological Society and in 1905 was elected a fellow of the Royal Society. He was a member of the International Commission for Scientific Aeronautics, and became an hon. or corresponding member of various foreign scientific societies. He is the author of many important papers on the meteorology of the upper atmosphere which appeared in the *Transactions of the Royal Society*, the *Geophysical Memoirs of the Meteorological Office* and elsewhere.

**DIPLOMACY** (see 8.294).—The general effect of the World War on the principles and practice of diplomacy, defined as the science and art of conducting negotiations between sovereign states, has been very great, for better or for worse; but in general it may be said that the war did not give the initial impulse to, but merely greatly strengthened, forces which had been long at work modifying the traditions of diplomacy and adapting it to new social and political conditions.

Long before the war the gradual development of a sense of the community of interests among civilized nations, and of the public law which was the outcome of this sense, had raised diplomacy to a far higher plane than that which it had occupied in the 18th century. Before the war, too, the progress of democracy had produced great changes in diplomatic practice. Delicate negotiations were, indeed, still conducted in secret, as they always must be; but publicity had already become a recognized diplomatic weapon to be used on occasion, and ambassadors, though still accredited to courts and governments, were sometimes—notably in the case of the United States and Great Britain—selected for qualities likely to appeal to peoples. Already, too, democratic sentiment was demanding open diplomacy, with popular control, while a host of publicists had long been busy devising schemes for an international order which, were it possible to realize it, would revolutionize diplomacy by establishing among the nations—to use President Wilson's language—"not a balance of power, but a community of power; not organized rivalries, but an organized common peace."

*General Effects of the War on Diplomatic Practice.*—These tendencies received a fresh impetus from the outbreak of the war. This disaster was widely ascribed to the machinations of diplomatists, who were denounced as representing not peoples but a class, as in league with capitalists and munition manufacturers to stir up war, as fraudulent trustees of the nations' welfare, who in their pitiful game of international chicanery habitually used language "false-friendly, circumlocutory, and non-committal, full of duplicity and secret reserves" (e.g. J. A. Hobson, *Towards International Government*, pp. 67, 69). The cure for this was to be to sweep away the diplomatic tradition altogether; to replace the trained diplomatic service by men directly representing popular opinion; and to secure effective "democratic control" by giving the deciding voice in all international questions to legislative bodies. These remedies for an assumed evil had the support of many sociologists and of many democratic politicians, especially in countries where parliamentary action on treaties was already required. Extend the system of democratic control, they argued, and crown the international edifice with a legislative assembly representing collective humanity, and peace will be forever assured, since the "peoples" never want war. This solution of the international problem, which ignored the fundamental difficulties, seemed to receive support in the highest quarters when President Wilson put forward his "programme of the world's peace." The very first of the Fourteen Points condemned "secret diplomacy." In future there were to be "open covenants openly arrived at, after which there shall be no private international understandings of any kind, but diplomacy shall proceed always frankly and in the public view." A "general association of the nations" was to be formed, in place of the partial alliances of former times (Point XIV.), and peace was to be made secure "by the organized major force of mankind."

The incorporation of the Covenant of the League of Nations in the Peace Treaty was an effort to realize the President's ideal.<sup>1</sup> From the point of view of the present article its main interest lies in the fact that it set up permanent machinery for that "diplomacy by conference" to which the work of settlement after the war gave a powerful development. For the rest, it cannot be said that the history of diplomacy from the time of the Armistice onward revealed any striking change in the old methods. Indeed, in so far as the traditional methods were departed from, the change was sometimes for the worse. The sounding phrases which had heralded the Peace Conference had only—as President Wilson himself confessed—raised in the hearts of millions of people hopes which could not be realized; and the enforced departure of the victorious powers from the promises and professions which they had made in their time of trouble did not inspire admiration for the new diplomatic morality. Nor was the assertion of this morality in the great Treaty a happy one. The preambles of treaties of peace in earlier times had perhaps been tinged with hypocrisy, since it was customary to describe the peace to be concluded as "Christian, universal and perpetual"—which nobody believed to be the truth. But even this pretence had its use, since it at least placed on record an ideal. In addition to this, however, it was usual to state that there was to be "complete oblivion of the past," a treaty of peace being conceived as a settlement of all outstanding differences and as clearing the ground for an entirely fresh start in the relations of the contracting parties (Satow, ii., p. 180). Whatever may be said of the guilt of the German nation in respect of the origin and conduct of the war, as justifying a departure from this tradition, the fact that in the Treaty of Versailles it was departed from is momentous. For the first time a treaty of peace was made to contain a confession of guilt on the part of the vanquished party, a confession permanently humiliating to a whole people. The old diplomacy, which was wholly practical, would not have made the mistake of introducing into what was intended as the foundation of the permanent order of the world a full charge of political dynamite of this description. The Allied statesmen of a hundred years ago did not thus humiliate France, even after the fresh outburst of the Hundred Days, though they were equally persuaded of her guilt and public opinion clamoured for her humiliation and dismemberment. But they were trained diplomatists, able to look into a future in which France, regenerated if not repentant, would again become a useful member of the European body politic. They cared not a rap for public opinion.

In general it may be said that the Peace Treaty of 1919 was the work of politicians, not of diplomatists; and this fact marks a significant change in the practice of diplomacy. Before the war the conduct of international affairs was, in Europe at least, in the hands of the trained diplomatic body working in connexion with the various Foreign Offices; and this international business was conducted according to an elaborate code of rules, established by custom or by convention, which had been devised as the result of long experience, to ensure its smooth working. At the Conference of Paris diplomatists were present, but they played but a secondary part. This was perhaps inevitable in view of the passionate interest of the peoples in certain aspects of the settlement, which forced those responsible for it to combine the functions of diplomatist and demagogue. But it had an unfortunate repercussion on the professional diplomatic service, of which it lowered the prestige.

This was especially the case, perhaps, in Great Britain. Even before the war there had been a tendency to pass over the professional diplomatists in making appointments to important embassies, which were occasionally, though as yet exceptionally, given to eminent party politicians. It is the system which has always prevailed in the United States, sometimes with excellent results—as in the notable succession of ambassadors to the Court

<sup>1</sup> For Mr. Wilson's conception, see his address to the Senate, Jan. 22 1917. Compare Mr. Asquith at Ladybank, Feb. 1 1917:—"A real European partnership, based on the recognition of equal rights and established and enforced by a common will."

of St. James's—but more often perhaps with results less satisfactory. Whatever may be said for this system, however, there can be no doubt that its considerable extension by the British Government since the war has dealt a severe blow at the diplomatic service; for how can men be expected to serve a long and arduous apprenticeship to a profession when they realize that its great prizes are given to outsiders who have served no apprenticeship at all?

Less obviously harmful was the outcome of the attacks from democratic quarters on the system of recruiting the diplomatic service in England. The object of this system, which demanded of candidates for examination nomination by the Foreign Secretary on the recommendation of persons of position and proof of the possession of an income of £400 a year, was to ensure the manning of the service by gentlemen, that is to say by those who had "at least had the opportunity of mixing in society where good manners are to be expected." In this system certain modifications were made as the result of a report issued in 1914 by the Royal Commission on the Civil Service. One of its recommendations was that the diplomatic establishment of the Foreign Office and the diplomatic corps abroad should be amalgamated, up to and including the grades of assistant under-secretary of state and minister of the lowest grade. This involved the abolition of the property qualification, which did not apply to the Foreign Office; and it was recommended that, in place of this, members of the service employed abroad should receive a suitable foreign allowance. After the publication of the findings of the Commission the recommendation of the Foreign Secretary was made dependent on the report of a board of selection composed of members of the Foreign Office and of the diplomatic service. In this there was nothing revolutionary; and the effect of the putting in force of these recommendations has been to widen the area of selection for the service. The danger lies in the denunciation as undemocratic of any principle of selection other than by the strict result of written examination. But the qualities required for a diplomatist, as Sir Ernest Satow rightly points out, cannot be ascertained by means of a written examination, which only affords evidence of knowledge already acquired, but does not reveal the essential ingredients of character (ii., p. 183). The character required for an efficient diplomatist will always be that implied in the best sense of the word "gentleman," meaning a man honourable, well educated, of good address and manners, and able to hold his own without self-consciousness in any company.

The whole body of rules and conventions for the regularizing of international intercourse, which is known as International Law, is the work of diplomacy, and it is the work of diplomatists to apply them. It follows that to be efficient they must be trained, and it is folly to suggest that the place of the trained diplomatist can be taken by a popular representative without experience or technical equipment. As Mr. Denys P. Myers has pointed out, by far the greater mass of diplomatic work consists in giving particular application to rules already universally admitted, a matter straightforward enough, but demanding technical knowledge. The remaining portion of the work is disproportionately difficult, since it consists in adjusting disputes about matters to which the application of existing rules is doubtful, or to which they admittedly do not apply, or which stand beyond all rules as questions of high policy. In such debates the diplomatist is necessarily an advocate; his object is not justice, but the advantage of the country he represents; and therefore "the art of which Socrates spoke, of making the worse cause appear the better, is inherent in every negotiation" (Myers, p. 208). Certainly the attempt of President Wilson to set up a standard of Right as the "acid test" of all claims between nations has altered nothing in this, and can alter nothing so long as nations differ in their conceptions of what Right is. Diplomacy must continue to be, in this aspect of its activities, frank advocacy of particular interests, even though the dispute be heard before the high court of the League of Nations. But this advocacy has been subject to certain rules, and in the interests of peace—which it has been the main purpose of diplomacy to preserve—it

has in course of time elaborated a highly technical phraseology of which the object has been to convey a plain meaning without being unpardonably offensive. This method may be "circumlocutory," but it is more calculated to keep the peace than democratic "plain-speaking." A peccant Government informed that such and such an act will be considered "unfriendly" will perfectly understand the threat conveyed, and it will be easier for it to yield than if the threat had been uttered in more unequivocal fashion. In short, the conventional forms used in diplomatic intercourse have a very practical use. In the words of the late Mr. E. C. Grenville-Murray, "they regulate the precise words of respect and courtesy necessary to be used on every occasion; they deprive argument of its heat and expostulation of its acrimony."<sup>1</sup>

*Secret Diplomacy and Democratic Control.*—In spite of President Wilson's denunciation of secret diplomacy, the negotiations before and after the Conference of Paris followed almost exactly the old practice. The organization of the conference itself was modelled closely on that of the Congress of Vienna in 1814. As at Vienna, all business of first-class importance was settled by the representatives of the Great Powers in secret conference, and the plenary sessions, to which alone the Press was admitted, were almost admittedly mere full-dress parades intended to produce an illusion of publicity. By a curious irony it was indeed President Wilson himself who was most violently attacked for neglecting the principle that diplomacy must always proceed in the public view. In the course of the long controversy between the President and the Foreign Relations Committee of the United States Senate about the Covenant of the League of Nations, which ended in the refusal to ratify the Treaty of Versailles, complaints were loud and reiterated that the Committee were kept completely in the dark as to the progress of the negotiations in Paris, although under the Constitution their treaty-making power was coordinate with that of the President. It was also urged against President Wilson that, in order to secure his sole control of foreign affairs, he had largely extended the custom of superseding, for the purpose of particular negotiations, the accredited agents of the United States—whose appointment was also subject to the advice and consent of the Senate—by personal agents of his own (Corwin, p. 64). The victory of the Senate over the President in the matter of the Treaty of Versailles was widely assumed to have settled in favour of the Senate's view the long controversy—it had raged intermittently since the days of Washington—about the powers of the President and the Senate respectively over the conduct of foreign affairs. President Harding, however, was hardly in office before he asserted as vigorously as any of his predecessors the sole right of the President to conduct negotiations. The right of the Senate to ask for papers has long been admitted, but the right of the President to refuse, in the public interest, to submit them seems equally clear (Corwin, p. 84 *seq.*).

The outcome of this controversy illustrates the fact that the war and the negotiations which followed have left the questions of secret diplomacy and of democratic control very much as they were before. So far as democratic control is concerned, wherever parliaments exist foreign relations come under their review, and can be controlled by their power of the purse; and it is their own fault if this control is not effective. "The ultimate misfortune of war," says Mr. Myers, "depends everywhere upon legislative financial support." But while control of broad policies is thus assured, there is no control of the processes of negotiation. It is, indeed, hard to see how such control could be attempted without creating a hundred difficulties and dangers for one which it would obviate. The point was admirably stated by Mr. Arthur Balfour in the House of Commons on March 19 1918, on a motion for a Standing Committee of Foreign Affairs:—

"I think the British world perfectly understands the broad ends for which British diplomacy works. . . . What is not simple, what is not plain, what is not easy, is the actual day-to-day carrying out of the negotiations by which these ends are to be attained. A Foreign Office and a diplomatic service are great instruments for preventing,

<sup>1</sup> *Embassies and Foreign Courts* (2nd ed., 1856).

as far as can be prevented, friction between states which are, or which ought to be, friendly. How is the task of peace-maker—because that is largely the task which falls to diplomatists and the Foreign Office which controls diplomatists—to be pursued if you are to about your grievances from the house-top whenever they occur? The only result is that you embitter public feeling, that the differences between the two states suddenly attain a magnitude they ought never to be allowed to approach, that the newspapers of the two countries agitate themselves, that the parliaments of the two countries have their passions set on fire, and great crises arise, which may end, *have ended* sometimes, in international catastrophes."

Mirabeau had said much the same thing in the French National Assembly in 1790, and subsequent history bore out its wisdom. It was not the diplomatists but the oratorical heat of the Legislative Assembly that plunged Europe into the wars of the Revolution. It was not public opinion, but the wisdom of the diplomatists on either side, which saved Great Britain and the United States from a renewal of war during the critical years that succeeded the Peace of Ghent in 1814. Had Castlereagh listened to the outcry of the British press and Parliament, had James Monroe and John Quincy Adams listened to the outcry of the American press and Congress, there would have been no hundred years of peace between the two countries. Instances might be multiplied. The world remembers the wars which diplomacy has failed to avert; it has forgotten, or has never known of those—and they are many more—which diplomacy has averted by a conspiracy of silence.

*Diplomacy by Conference.*—The most striking development of diplomatic practice since the beginning of the World War has been the increasing practice of direct negotiations in conference between the heads of governments, or between the principal ministers of departments concerned in the subjects under discussion. The practice is, of course, not new. The similar circumstances of the great war against Napoleon had produced similar results in the long series of conferences from that of Châtillon early in 1814 to the Congress of Verona in 1822; and Castlereagh had at the outset commended the convenience of the system, which promised to endow the councils of the Powers "with the efficiency and almost the simplicity of a single State." The practice arose in both cases from the necessity of reaching swift decisions. It is clear, indeed, that the problems to be solved by the Allies during the war were too varied, too technical, and generally too urgent to be dealt with solely through the ordinary diplomatic channels. The practice of direct negotiation between the heads of governments was an obvious counsel of expediency, and began early in 1915 with the visit of M. Millerand to London. In Feb. of the same year there was a meeting of Finance Ministers in London; but the first meeting of the heads of the Allied Governments was that at Calais on July 6. On Nov. 17, at a conference in Paris, it was decided in principle to establish a permanent machinery for coordinating the efforts of the Allies, and on Jan. 19 1916, at a meeting of Mr. Asquith and M. Briand in London, rules for the establishment of an Allied Committee were approved by them. This plan was first applied at the great conference opened at Paris on March 26, at which the prime ministers of France, Italy, Belgium and Serbia were present, together with representatives of Japan, Russia and Portugal. It is unnecessary to give here a list of the further conferences that followed. The significant thing is—to quote Sir Maurice Hankey—that "in the forcing-house of war the governmental machinery of a veritable League of Nations had grown up, whereby the will of the Allied peoples to win could be put into effect" (p. 15). The system of diplomacy by conference thus revived reached its fullest development, of course, in the great Peace Conference at Paris, and in the League of Nations an attempt was made to give it a permanent organization.

In addition to the advantage of rapidity of decision arising from this system, the claim has been made for it that the statesmen ultimately responsible for the policy of their respective countries become personally well acquainted, and that the intimacy and even friendship which tend to develop out of these meetings make possible an interchange of confidences which would otherwise be impossible. This is, of course, perfectly true. It is also true that, in view of the closer interdependence of the

nations and the vast complexity of their economic relations alone, the old system of diplomacy is no longer sufficient and that "diplomacy by conference has come to stay" (*id.*, p. 25). If this means that the conferences of experts on this or that matter of international interest are to continue, there is nothing to be said against it. If it means that periodical meetings of heads of governments are to be erected into a permanent system, the case is far more doubtful. It may be doubted whether the cause of peace will permanently gain by taking the conduct of all serious international negotiations out of the hands of trained diplomatists and putting them into those of politicians unversed in diplomatic technique and sensitive to every shifting current of public opinion. Certainly the unrestful world left by the Peace Conference gives evidence enough of the disastrous results of the sounding phrases which heads of governments had used with so much effect on public platforms. Nor is a rapid decision on matters of controversy by any means always a good thing. The world has often been saved from war by the diplomatic dragging out of negotiations until public excitement on either side has subsided. Finally, there is the objection to too frequent conferences urged by the British Government at the time of the Congress of Aix-la-Chapelle in 1818, which has not lost its validity. They tend, as Lord Bathurst put it, to "keep the mind of Europe afloat," by suggesting to discontented peoples that no settlement is final and that, the machinery for change being permanent in the conferences of the powers, a long and loud agitation will suffice to set it in motion. It may be that the conference system will—as the creators of the League of Nations maintain—provide a safety-valve for the expansive forces of nationalism; but there is a danger that it may operate in another way, by not allowing these forces to cool. The introduction of an organized legislative element into international relations is thus somewhat of an experiment, and no one can say confidently how it will work out. In any case, however, there will still be room for the old diplomacy in its quasi-legal function of applying the acknowledged public law, and in its trained ability to adjust differences lying beyond it.

*Functions and Rights of Diplomatic Agents.*—The new and more complicated conditions under which the World War was fought naturally added fresh problems to those which the old writers on diplomacy had discussed, as to the activities proper to those representing the interests of their Prince at a foreign court. Such questions were raised during the war more especially by the activities of the diplomatic agents of the belligerent states accredited to neutral governments. The duty of these agents being to forward the interests of their own states, what limitations was it proper and necessary to observe in carrying out this object? In effect, the answer to this question was found, not in establishing new principles, but in applying old principles to new conditions. The old definition of the ambassador as "an honourable spy" certainly applied during the war. In all neutral countries it was the duty of diplomatic agents to collect information useful to their governments, and to act as centres for an active propaganda of their views and aims. In certain cases, as Switzerland and Holland, neutral countries were made the bases of propaganda and espionage in enemy countries, and these activities were carried on more or less under the supervision of the ministers accredited to the neutral countries. So long as this propaganda did not pass certain bounds there was nothing in this that did violence to the traditional principles of diplomacy, though propaganda had never before been organized on so vast a scale. Nor was the organization of a spy system, centred in neutral countries, a violation of diplomatic propriety, since in this respect all the belligerent nations exercised equal rights.

It was otherwise when, diplomatic privileges and immunities were used to cover indirect attacks on the enemy through neutral interests. The most outstanding instances of this arose from the efforts of the Central Powers to interrupt the supply of arms and ammunition to the Allies from the United States. In Sept. 1915 the interception of a letter from Dr. Dumba, Austro-Hungarian ambassador in Washington, to Count Burian proved that the Austrian embassy, with the approval of the German, was con-

contingent financing, strike movements on a large scale in the United States in order to hamper the manufacture of munitions. At the instance of the United States Government Dr. Dumba was recalled. Count Bernstorff had previously been forced to apologise for his want of diplomatic courtesy in publishing, without first submitting it to the American Government, a denunciation of the un-neutral conduct of that Government in permitting the export of munitions of war to the Allies. Even more serious, however, was the subsequent discovery (Oct.) that Captain Boy-Ed and Captain von Papen, the naval and military attachés to the German embassy, had been active in a plot to destroy American munition factories and American ships carrying munitions. Their subordinates, who were not covered by diplomatic immunity, were imprisoned; the two attachés were recalled at the instance of the United States Government. The same fate befell Count Luxburg, German minister in Buenos Aires, the author of the famous advice that ships carrying food from the Argentine to the Allies should be "spurious versenkt" (sunk without leaving a trace). These notorious cases, characteristic of many others, involved no new statement of principle, for they were clearly condemned by the traditional standards of diplomacy. "The ambassador," Callières had written in the 18th century, "may suborn the Prince's subjects for the purpose of obtaining information, but not for the purpose of plotting against their master." Equally clear was the principle condemning the practice of the German diplomatists, especially in the United States, of plotting attacks on enemy states (e.g. Canada, Ireland) under cover of their immunities. This was an abuse of diplomatic privilege, since it injured the state in which the plots were hatched by imperilling its neutrality.

See Sir Ernest Satow, *A Guide to Diplomatic Practice* (2 vols., 1917); Denys P. Myers, "Notes on the Control of Foreign Relations," in part iii. of the *Recueil de Rapports de l'Organisation Centrale pour une Paix durable* (The Hague, 1917), pp. 285-382, an invaluable study of the essential conditions under which diplomacy works; Edward S. Corwin, *The President's Control of Foreign Relations* (1917); Sir Maurice Hankey, *Diplomacy by Conference* (1921). In *Democracy and Diplomacy* (1915) Mr. Arthur Ponsonby, who was in the diplomatic service from 1894 to 1903, puts the case for "democratic control"; an appendix contains the findings of the Royal Commission.

(W. A. P.)

**DISEMBARKMENT CONFERENCE:** see WASHINGTON CONFERENCE.

**DIVORCE** (see 8,334).—(I) UNITED KINGDOM.—In the law of divorce administered in England and Wales there was no change between 1910 and 1921 except as to procedure by poor persons, and in Scotland and Ireland there was no change at all. But in England since 1910 the subject has become one of acute controversy, and there has also been a remarkable increase in the number of divorces granted. The report of the Royal Commission appointed in 1909 was not published till 1912. The appointment of the Commission, and the Majority Report advocating increased facilities for divorce, were both backed by an influential body of prominent persons outside the Commission itself. The inquiry was dominated throughout by the late Lord Gorell (formerly Sir Gorell Barnes) who had previously practised in and presided over the Divorce Court, and who held very strong views in favour of the extension both of the reasons and facilities for divorce in all classes of society. But the recommendations of the Majority Report have been strenuously opposed, especially in the Church of England, which has been practically unanimous in condemning the present system of divorce and opposing its extension.

Most of the recommendations of the Commission were, however, embodied in a bill which passed the House of Lords in 1920, but was abandoned in the House of Commons. A new bill was introduced in the House of Lords in 1921 by Lord Gorell, the son of the chairman of the Commission mentioned above. The bill is based on the recommendations in which all the members of the Commission were in accord. The Lord Chancellor has also presented a report embodying the reform of procedure so as to give easier divorce to the poorer classes.

The Commission took evidence from lawyers and officials to a much greater extent than from any other class, and much of the Majority Report was highly technical and official. The point of

view of the ordinary man and woman is better represented by the Minority Report, published in 1912 in the same Blue Book (Cd. 6478). Women were represented on the Commission by Lady Frances Balfour and Mrs. H. J. Tennant—the latter of whom added a valuable separate memorandum to the Majority Report. The Minority Report agrees to certain changes in procedure intended to bring divorce within the means of labour and the poor middle-class, but strongly warns the public on the experience of France and America not to extend the reasons for divorce.

The recommendations of the Commission are given below, those embodied in the two bills presented being distinguished from those rejected or ignored. Following the report of the Commission, the scheme of bill No. 1 was to save expense by bringing the court locally to the home of the applicant. This was to be effected by rules giving power to certain selected county court judges to act as judges in divorce and other matrimonial causes. Each cause for divorce or nullity or judicial separation was available by this bill to either husband or wife so that it was intended that, e.g. adultery or desertion alone should in future enable a wife to obtain a divorce and vice versa, the sexes being treated on an absolute equality.

The causes for divorce included in No. 1 bill (1920) are (a) adultery, (b) desertion, (c) cruelty, (d) insanity continuous for five years and certified as incurable, (e) "incurable habitual drunkenness." Any one of these causes was to be sufficient. A cause rejected by the bill was imprisonment in lieu of commuted sentence of death. Causes rejected by the Commission were disease (except as below), unconquerable aversion, and mutual consent. In addition to the above the causes in the bill for which nullity of a marriage can be obtained are (a) physical incapacity, (b) unsound mind or epilepsy at the time of marriage or within six months after; (c) venereal disease communicable at the time of marriage, (d) pregnancy at the time of marriage caused by some person other than the husband. Permanent judicial separation is allowed in the (1920) bill on any ground available for divorce, and the court may in its discretion convert the decree for judicial separation into a decree nisi for divorce, unless the applicant prefers to have the application dismissed. These last provisions are as recommended by the Commission to meet the conscientious scruples of the vast majority of the Church of England as well as of Roman Catholics and others who object to any divorce which enables either party to remarry.

Besides the consideration of what should be the grounds for divorce in future, the commissioners were most anxious to bring "the benefits of the law" to the poor and to remove the complaint that divorce is still the privilege of the comparatively rich. This the majority recommended should be done by selecting some of the county court judges to go round and hold divorce courts locally. A step in this direction was taken in the Administration of Justice Act (Dec. 23) 1920, which provided for divorce cases being heard at Assizes. The right to a jury was retained.

The bill presented by Lord Gorell in 1921 makes adultery by either husband or wife sole cause for divorce, but a marriage can be made null and void for (a) incapacity or wilful refusal to consummate, (b) unsound mind or epilepsy under certain conditions, (c) venereal disease at the time of marriage or (d) pregnancy by some person other than the husband existing at the time of marriage. With regard to (b), (c), and (d) the applicant must prove that at the time of marriage he or she was ignorant of the fact alleged; proceedings must be taken within a year from marriage and marital intercourse must not have taken place after discovery of the fact alleged by the applicant. Connivance, condonation and collusion by the applicant bar his application and remain absolute defences as before. The Court is to have a discretion to override the following *defences*: adultery, cruelty, desertion, unreasonable delay, neglect or misconduct by the applicant. Judicial separation can be obtained for habitual drunkenness if the applicant has used all reasonable means to reform the defendant and has not caused or conducted to it by his own conduct. Presumption of death can be decreed by the Court in proper cases and in particular where defendant has not been known by the applicant to be living for seven years. Juries in matrimonial cases are abolished by the bill, as are damages against the co-respondent beyond the actual pecuniary loss sustained by the applicant, but the co-respondent may be ordered to pay the whole of the costs and to settle property or make payments to "the parties to the marriage or either of them or the children of the marriage" according to his or her ability. It is clearly intended to make women



liable as co-respondents. There are improved provisions as to the custody and maintenance of the children and for preventing the parties from getting rid of their property during the proceedings. A British subject domiciled in England or Wales but resident in any other British possession who has obtained a divorce there may apply to the High Court in England to register the decree as a decree nisi. The wife whose husband has deserted her or been deported and whose domicile was at the time of desertion or deportation in England or Wales shall be considered so domiciled for the purposes of matrimonial causes. In cases where the wife so domiciled has married a foreigner and the marriage has been declared null and void by the Court of the husband's domicile, the High Court may pronounce the marriage null notwithstanding that the marriage was valid according to the law of the place where it was celebrated. This is to meet the very hard cases of French and other laws. In France the want of the parents' consent makes an otherwise valid marriage which has taken place in England void, so that the English subject so married remained tied in England though unmarried in France. The rule that refusal to comply with a decree for restitution of conjugal rights is "desertion" it is proposed to abolish, but on the other hand refusal of marital intercourse without reasonable cause is to be deemed desertion, and if one party has in good faith requested the other to return to cohabitation the refusal so to do within "a reasonable time" is to be deemed desertion. Neither desertion nor cruelty without adultery was to be a good ground for divorce (see below). The bill further proposes to regulate separation and maintenance orders by Courts of Summary Jurisdiction to be granted for cruelty, habitual drunkenness, or venereal disease. The bill provides for the orders to last two years only unless converted into decrees for judicial separation in the High Court. The applicant who obtains one of these summary orders is to have police protection against the defendant, and maintenance is to be collected by a court official. An important proposal of the bill is to make it contempt of court to publish any report or pictorial representation of the matrimonial proceedings until the conclusion of the case, and to exclude the public but not the reporters in the discretion of the judge.

This bill was almost uncontroversial as originally introduced but the advocates of divorce insisted on desertion being made a sole ground, and the bill (May 1921) was so printed in the House of Commons. This produced a reaction and the increase of divorce cases in 1920-1 accentuated the differences of opinion.

The reasons for the recommendations of the Commission on other points also demand more notice. The most serious problem raised is the question of allowing adultery by the husband to be the sole ground for divorce. This was treated by the majority very superficially as a question of the equality of the two sexes before the law; but in reality it is a much more serious problem. The idea of divorce by mutual consent is rejected by the majority, not so much on principle as on the ground that there is no demand for it. But divorce by mutual consent is already *de facto* in existence, and if the husband's adultery is made a sole cause it will be greatly extended. This is a point on which, among those well acquainted with the facts, there is no great difference of opinion (see Minority Report p. 180: evidence Mr. Justice Bargaive Deane, p. 848). It has been recognized law in England for a generation past that refusal by the husband to obey a decree to return to his wife, coupled with proof of adultery, entitles the wife to an immediate divorce. It has therefore become the common practice, where both parties desire a divorce, for the husband to leave the wife, who writes him a letter asking him to return. He refuses. She brings her suit. An order is made on the husband to return in 14 days, which he disobeys. He lets the wife know where proof of adultery can be found and a divorce is the result. This is not "collusion" in law, but it is what the public mean by collusion, and the number of these cases was even in 1918 nearly as great as the whole number of divorces in 1857 and has been greater since. If there were any desire to decrease the number of divorces this should be stopped. But the 1921 bill on the contrary proposes following the Majority Report that the husband's adultery alone should be a sufficient ground for divorce. No wife will ever commit adultery in order to get a divorce; because her adultery, if acknowledged, makes her a social outcast; but there is no such ostracism of the husband. At present the husband is deterred from seeking a divorce if he is obliged to admit cruelty. Desertion for three years, as proposed in both the bills, is not quick enough to be any temptation to collusion. But there could be no doubt that if the husband's adultery alone is made a sufficient ground it would greatly increase the number of divorces.

The increase in number was already enormous; as will be seen by the figures given below, taken from the official "Civil Judicial Statistics" (Part II, up to 1919).

The average number of petitions of divorce (apart altogether from suits for nullity and judicial separations, as to which there was no increase) for the years 1885 to 1900 was:—

	1885-90	1891-5	1896-1900
Petitions . . . . .	511	543	650
Decrees Nisi . . . . .	378	391	501
Restitution Orders . . . . .	21	18	21

The number of petitions seems as important in considering the disturbance in married life as the number of divorces. The annual number of cases between 1900 and 1919 was:—

	Petitions (Divorce)	Decrees Nisi	Decrees Absolute	Restitution Ordered
1901	750	601	477	30
1902	889	608	601	33
1903	825	614	606	31
1904	720	634	528	35
1905	752	623	604	45
1906	767	650	546	84
1907	734	598	644	49
1908	846	672	638	65
1909	787	685	694	72
1910	755	658	590	59
1911	859	655	530	50
1912	920	690	587	123
1913	998	870	577	158
1914	1,075	658	373	136
1915	1,143	1,050	668	136
1916	1,163	1,086	972	159
1917	1,423	946	683	159
1918	2,323	1,407	1,082	236
1919	5,085	2,610	1,629	210

It will be seen from the table that the number of petitions for divorce (apart from those for judicial separation) increased from 750 in 1901 to 2,323 in 1918, that is at a rate of over 224% in 18 years. As even larger number was shown in 1919-21. The population of England and Wales in the same years increased by regular increments from 32,612,022 in 1901 to 36,800,000 in 1919. The latter year is taken to avoid complication as to demobilization. The increase is a little over 12%, so that if the increase of population were the only cause the number of petitions would in 1918 have been about 849 instead of 2,323.

The rate of marriage is rather more variable. The number of marriages in England and Wales was:—

1901	1902	1903	1904	1905
259,400	261,750	261,108	257,856	266,748
1906	1907	1908	1909	1910
270,038	276,421	264,940	260,544	267,221
1911	1912	1913	1914	1915
274,943	283,834	286,583	294,401	360,885
1916	1917	1918	1919	
279,846	258,853	287,163	369,411	

The years 1915 and 1919 were abnormal years, and in both the number of marriages was much higher than in any previous year. This is accounted for by mobilization in 1914-5 and demobilization in 1919. If the rate be taken on the figures 1901-19 the increase was only a little over 18%. The increase of petitions in 1913 is almost exactly at the same rate as the increase in marriages. But the rate of increase in petitions in 1919 was more than double the increase in the marriage rate. If the petitions continue to increase at the same rate for another 18 years there will be 5,152 of them in 1936. The proportion of petitions to marriages in 1901 was less than one-third of 1%. It was nearly two-thirds of 1% in 1919. The registrar-general of births, deaths and marriages in his Report for 1919 (Cmd. 1017) says "the number of divorces obtained in 1919 was about 50% greater than in 1918, which was itself the highest up to that date, and with the increase in divorces there has been a corresponding increase in the number of persons who on remarriage described themselves as divorced." He adds that the war is "largely responsible for the sudden increase of the last two years, but as the frequency of divorce as recorded in the table has been increasing for many years it can hardly be expected that the pre-war level will be restored." The warning of the Minority Report is illustrated by these figures. In 1918 the number of divorce petitions exceeded the number in 1917 by 900, and in 1919 rose to a total of 4,317, or an increase of 1,994. Petitions by husbands have largely increased since 1910. Petitions by wives have fallen off since 1914. The figures as to "poor persons' suits under the system initiated in 1914 show that nearly five-sixths of these cases were for divorce. There were no fewer than 10,108 applications in the five

years, of which, however, nearly half were refused. The total number of husbands' petitions in 1917 were 1,067 against 638 by wives. There were no children in 660 of these 1,705 cases. In 1918 the husbands' petitions rose to 1,837 and the wives' to 837 for all classes of cases. There were no children in 1,043 of these cases. The duration of these marriages is another interesting point. The marriages which had lasted over five years and less than twenty were 1,149 out of 1,705 in 1917 and 1,788 out of 2,688 in 1918.

**Scotland.**—In Scotland, after the Reformation, adultery was introduced as a cause for divorce without statute, apparently upon scriptural grounds, and as a consequence of the abolition of the pope's jurisdiction in Scotland. Prior to the Reformation, marriage had been looked upon in Scotland, as in other Roman Catholic countries, as a sacrament; after the Reformation it came to be regarded from the point of view of a contract, of a peculiarly solemn and far-reaching nature, but which might be dissolved consistently with public morality, and divorce for adultery was at once introduced. Wilful desertion was confirmed by statute in the year 1773 as a ground for divorce, four years being then fixed as the period for which the desertion must subsist, and that period has since been maintained until the present day. From the evidence of Lord Salvesen (vol. 1, p. 254) it appears that in 1908 110 decrees for divorce were granted for adultery, of which 59 were at the instance of the husband and 51 at the instance of the wife; and that, in the same year, 81 decrees for divorce were granted for desertion, of which 20 were at the instance of the husband and 61 at the instance of the wife; and the statistics show that the number of divorce cases has, relatively to the population, continued about the same.

It has been the statute law in Scotland since 1600 that the guilty spouse cannot marry the paramour during the lifetime of the other spouse, but in practice this has been generally evaded by not putting the name of the paramour into the decree of divorce. The large proportion of the divorced husband's property allowed to the wife and children by the law of Scotland is believed to have a considerable effect in reducing the number of divorces.

**Ireland.**—In Ireland, where the majority of the population are Roman Catholics, and where, apparently, conditions of life differ materially from those in England, divorce *a vinculo* of parties there domiciled is only obtainable (as in England before 1857) by private Acts of Parliament, after a divorce *a mensa et thero* has been granted by the King's Bench Division of the Irish High Court (which now exercises the powers of the old Ecclesiastical Courts), and (if the suit be by the husband) after judgment has been obtained in an action in the Irish courts for crim. con., the minimum evidence for such proceedings being two witnesses. (See evidence of Mr. Roberts, 42,663; 42,627.) Since the passing of the Divorce and Matrimonial Causes Act, 1857, there have been 39 Private Divorce Acts (Mr. Roberts, 42,624).

**Isle of Man.**—Divorce *a vinculo* can only be granted by Act of Tynwald, founded on a decree of judicial separation granted by the Chancery Division of the High Court of Justice in the Isle of Man, which, by the Ecclesiastical Civil Jurisdiction Transfer Act, 1884, has jurisdiction in matrimonial matters, and follows the principles upon which the Ecclesiastical Courts acted.

**Channel Islands.**—There appears to be no right to proceed to obtain judicially a divorce *a vinculo*, and there have been no legislative proposals with that object.

(II.) BRITISH DOMINIONS

**India.**—The dissolution of marriage among the Christian communities in India, whether European, domiciled or country-born (save that in the native states the Act applies to British subjects only), is regulated by the provisions of Act IV. of 1869, usually called the Indian Divorce Act, under which decrees of divorce may be granted on grounds similar to those which exist at the present time in England, and where, since the marriage, a Christian husband has abandoned Christianity. Jurisdiction to grant any relief under the Act is confined to cases where (a) the petitioner professes the Christian religion, (b) resides and is domiciled in India at the time of presenting the petition, and (c) the marriage was solemnized in India. The two latter restrictions have inflicted in numerous cases great hardship, and the Commission made some suggestions thereon, which it is now proposed to incorporate in a special Act. The decision of Sir H. Duke in *Keyes v. Keyes* (1921) only emphasized the above which was good law before. It may be noted in passing that, by section 495 of the Indian Penal Code, adultery is made a criminal offence in the case of a man who, without the consent or connivance of the husband, has illicit intercourse with a woman who is known to be the wife of another man.

**Canada.**—The British North America Act, 1867, by section 91, conferred upon the Parliament of Canada exclusive legislative authority in relation to marriage and divorce, but by section 129 all laws in force in the provinces of Canada, Nova Scotia and New Brunswick were continued in such provinces respectively, and, by section 146, the provisions of the Act were extended to other provinces admitted to the Union. In the provinces of Nova Scotia, New Brunswick, Prince Edward I. and British Columbia, there existed at the time of the Union courts of divorce, and they still continue to exercise their functions. The grounds in those provinces are as

follows: in Prince Edward I. and New Brunswick, adultery; impotence, or consanguinity, and, in Nova Scotia, cruelty as well.

The Privy Council, the highest court of appeal, decided in 1919 (*Walker v. Walker*) that the English Act of 1857 applies to and is part of the substantive law in all the provinces of Canada except Ontario and Quebec. There being no divorce courts in Ontario and Quebec, recourse for relief must be had to the Parliament of Canada by private Act.

**Union of South Africa.**—(a) Cape Province.—According to Roman-Dutch law, which is in force in that province, the grounds upon which divorce may be granted are adultery, malicious desertion, unnatural crime, perpetual imprisonment, long absence, and refusal of marital privileges, though it would appear that recourse is seldom, if ever had to the latter four grounds. (b) Province of Natal.—Divorce is granted on the ground of adultery or malicious desertion for not less than 18 months before the suit. These provisions, however, do not apply to the native tribes, which are governed under their own system of laws.

**New South Wales.**—By the Matrimonial Causes Act, 1899 (Act No. 14, 1899), Part IV., ss. 12-66, divorce is granted, on the petition of a husband, for the adultery of the wife, and, on the petition of a wife, for the adultery of the husband, if the husband is domiciled in New South Wales when the suit is instituted, or such adultery is incestuous, or coupled with (a) bigamy, or (2) cruelty, or (3) desertion, without reasonable cause or excuse, for three years or upwards. In addition to the above, on the petition of either party, it is granted for malicious desertion during three years or upwards on the ground that the husband has, during those years, been a habitual drunkard, and has left his wife without means of support, or has been guilty of cruelty; on the ground that the wife has, during three years, been a habitual drunkard, and has neglected her domestic duties, or been unfit to discharge them; on the ground of imprisonment for three years under commuted sentence for a capital crime, or under sentence of seven years or upwards, on the ground of conviction for attempt to murder or inflicting grievous bodily harm; on the ground of the respondent repeatedly assaulting and cruelly beating the petitioner; on the ground that the husband has been in the last five years frequently convicted, and has had sentences of three years in the aggregate, and has habitually left his wife without support.

**New Zealand.**—By the Divorce and Matrimonial Act 1908, No. 50, as amended by the Acts 1912, No. 22, 1913, No. 69, 1919, No. 53; and 1920, No. 90, either husband or wife can obtain a divorce for adultery or wilful desertion for three years. If the wife is living separated and the husband leaves her without reasonable maintenance for three years he is deemed to have wilfully deserted her (Act of 1913). If either husband or wife fails to comply with a decree for restitution of conjugal rights the other can obtain a divorce forthwith, and the Court may in its discretion dissolve any marriage on the petition of husband or wife where the parties have been living separate for three years under decree of judicial separation or magistrates' order or deed or merely by mutual consent (Act of 1920). Where the husband has been an alien enemy the wife, if a natural-born British subject, can divorce him if he has left New Zealand for more than 12 months (Act of 1919). Habitual drunkenness for four years coupled with cruelty or with leaving the wife without means of support, or, in the case of the wife, coupled with neglect of domestic duties, is also a ground for divorce. Other grounds are conviction and sentence of seven years or upwards for attempting to take the life of the petitioner or any child of the petitioner or respondent or the conviction of the murder of such a child or the fact of being a lunatic confined in New Zealand for an aggregate period of seven years within 10 years of the filing of the petition.

**Queensland.**—By the statutes of Queensland, Matrimonial Causes Jurisdiction Act of 1864 (28 Vict. c. 29) and Matrimonial Causes Act of 1877 (39 Vict. c. 13), the provisions of the imperial statutes (20 and 21 Vict. c. 85, 21 and 22 Vict. c. 93, 21 and 22 Vict. c. 108, and 22 and 23 Vict. c. 61) are re-enacted, so that the law is substantially the same as in England.

**South Australia.**—In South Australia divorce is granted on the same grounds as in England, except that in the case of adultery coupled with desertion in a wife's suit one year's desertion is substituted for two years.

**Tasmania.**—The provisions of the imperial statutes (20 and 21 Vict. c. 85, 21 and 22 Vict. c. 108, 22 and 23 Vict. c. 61) have been made applicable by statute in Tasmania, so that the law is substantially the same as in England.

**Victoria.**—In Victoria the petition may be presented and decree granted on the same grounds as those at present existing in England. In addition to the above, on the petition of a petitioner domiciled for two years in Victoria, a decree may be granted on the ground of desertion for three years, on the ground that the respondent husband has been a habitual drunkard for three years, and has left his wife without means of support, or has been guilty of cruelty; on the ground that the respondent wife has been a habitual drunkard for three years, and has neglected her domestic duties, or rendered herself unfit to discharge them; on the ground of imprisonment for three years, under commuted sentence for a capital crime, or under sentence of penal servitude for seven years or upwards; on the ground

of a conviction within one year previously for attempt to murder the petitioner, or of having assaulted him or her with intent to inflict grievous bodily harm, or on the ground that the respondent has repeatedly during that period assaulted and cruelly beaten the petitioner; on the ground that the respondent husband has been, in the preceding five years, frequently convicted of crimes, and has been sentenced in the aggregate to imprisonment for three years, and has habitually left his wife without means of support; on the ground that the respondent husband has been guilty of adultery in the conjugal residence, or coupled with circumstances or conduct of aggravation or of repeated acts of adultery.

*Western Australia.*—Until 1912 the divorce laws of this state, which were regulated by an ordinance (27 Vict. No. 19), were similar in all respects to the laws of England, but Act No. 7 of 1912 contains material alterations in the law.

The causes upon which the divorce may be granted, as enumerated in that Act, are adultery; malicious desertion for five years; on the ground that the respondent (husband) has been a habitual drunkard for four years, and has either habitually left his wife without means of support or has been guilty of cruelty towards her; or, the husband being the petitioner, that his wife for a like period has been a habitual drunkard, and has habitually neglected her domestic duties or rendered herself unfit to discharge them; on the ground of imprisonment for three years under commuted sentence for a capital crime or under sentence for seven years or upwards, or, the wife being the petitioner, that the husband has been in the last five years frequently convicted, has had sentences of three years in the aggregate, and has habitually left his wife without means of support; on the ground of conviction for attempt to murder the petitioner or inflicting grievous bodily harm on him or her; further, on the ground that the respondent is a lunatic or a person of unsound mind, has been confined in an asylum or other institution in accordance with the provisions of the Lunacy Act of 1903 for a period or periods not less in the aggregate than five years within six years immediately preceding the suit and is unlikely to recover.

### (III.) EUROPEAN COUNTRIES

It should be kept in mind that in all countries the Roman Catholic Church absolutely forbids its adherents to apply to the civil courts for a divorce *a vinculo*, and in modern European states there is frequently a conflict between the law of the State and the law of the Church on this subject. In certain cases the Church permits the spouses to separate and will sometimes annul a marriage if properly approached.

*Austria.*—In Austria, among Protestants, divorce may be granted on the ground of adultery, namely, the adultery of the wife, condemnation for crime, immoral habits, infectious diseases, ill-treatment, threats or serious vexations, unconquerable aversion; and among the Jews by mutual consent, or on the adultery of the wife.

*Belgium.*—In Belgium, divorce is granted on the following grounds, namely, the adultery of the wife, the adultery of the husband if he shall have kept his mistress in the common residence, violence endangering life (*exces*); cruelty (*stices*); grave indignities (*injures graves*); sentence of one of the parties to an infamous punishment involving loss of civil rights, mutual and unwavering consent of the parties expressed in manner prescribed by law.

*Bulgaria.*—By the law of the orthodox Greek Church, and therefore of Bulgaria, divorce *a vinculo* only is recognized. It may be granted on the grounds of adultery, cruelty, threat or designs against the life of the other party to the marriage, absence of the husband for four years if his whereabouts are unknown, or, if his whereabouts are known, without sending his wife means of support; impotence; insanity; epilepsy; idiocy, or syphilis supervening after marriage and incurable; sentence to severe or degrading punishment for theft, fraud, embezzlement or homicide; unsubstantiated charge of adultery made by one party to the marriage against the other; unnatural crime of the husband upon his wife; restraint on religious liberty; drunkenness, when accompanied by squandering property or destroying the home, or an otherwise disorderly or dissolute manner of life; abandonment of the husband by the wife, driving him from his home without sufficient grounds followed by refusal for three years to live with him again.

*Denmark.*—In Denmark judicial divorces are obtainable on the grounds of adultery, bigamy, desertion (if malicious, after three years, if simple, and absence without known or apparent cause, after seven years), absence for five years where the presumption is that the absentee is dead, imprisonment for life. Administrative divorces may also be obtained on the grounds of insanity, separation for three years, sentence of three years' penal servitude.

*France.*—In France, divorce, which had been introduced for the first time in 1792, but had been abolished at the Restoration in 1816, resumed its place in the Civil Code in 1884. The grounds upon which it is now permitted are adultery, violence endangering life (*exces*), cruelty (*stices*), grave indignities (*injures graves*), condemnation of either spouse to an afflictive punishment.

*Germany.*—By the German Civil Code of 1900 all the previous laws of the federal states have been abolished, and the absolute

grounds upon which decrees for divorce are now granted throughout the German Reich are adultery, bigamy, crime against nature, attempt on the life of the other party to the marriage, malicious desertion for one year, insanity of three years' duration after the marriage, destroying intellectual communion between parties, and holding out no hope of recovery. The Court has a discretion to grant divorce on the ground of serious breach of conjugal duties, and dishonourable or immoral conduct, under which all vices and bad habits may furnish a sufficient ground.

*Greece.*—Divorce in Greece is regulated by the Roman and Byzantine laws, in accordance with the provisions contained in the collection of Harmeropoulos. The grounds for divorce are established in No. 117 of the *Novellæ Constitutiones* of Justinian (and some important amendments) and are, on the petition of the husband, adultery; that the wife attempted the life of her husband, or, being aware of plots against it, has not disclosed them to him; non-disclosure to her husband of knowledge of a conspiracy against the sovereign; without her husband's consent staying the night at another house, except the house of her parents; without her husband's consent attending races, theatres or sports; against her husband's wish attending dinners or bathing in the company of men; procuring abortion. On a wife's petition, the grounds are, that the husband entertained schemes against the sovereign, or, being aware of such, has not denounced them to the authorities; that the husband has attempted the life of his wife, or, being aware of plots against it, has not disclosed them to her, or undertaken to prosecute the authors of them; that he has endeavoured to procure her to commit adultery; that he has brought a false accusation of adultery against her; adultery in the conjugal home; adultery in the town, if persisted in; impotence of husband, existing before marriage and continuing at least three years after it.

*Hungary.*—Prior to 1894, each religious denomination was governed by separate regulations, but in that year marriage and divorce in Hungary and Transylvania were regulated by the 68 Marriage bill of that year which came into force in 1895; and absolute grounds upon which divorce is permitted by the State (as note above), without distinction of creeds, are adultery; unnatural crimes; bigamy; desertion; attempt upon life or serious maltreatment endangering safety or health; sentence of death or penal servitude or imprisonment for five years. The discretionary grounds are violation of marital obligations, other than above; inducing or attempting to induce a child of the family to a criminal act or immoral life; the respondent persisting in leading an immoral life.

*Italy.*—No divorce is permitted.

*The Netherlands.*—Adultery and malicious desertion under Roman Dutch law; and, by more recent addition, imprisonment for five years; grave injuries or ill-treatment endangering life; a lapse of five years after a judicial separation (by consent or otherwise) without reconciliation, are now grounds for divorce.

*Norway.*—The Norwegian Act of Aug. 20 1909 has effected radical changes in the law. Either party to the marriage is now entitled to divorce, where, at the time of marriage, the other spouse, without the knowledge of the former, has suffered from a physical defect making him or her unsuited for marriage, or from epilepsy, or from or from venereal disease in an infectious form, or from insanity; or (the husband being the petitioner) where the wife has been maltreated by someone other than the husband; where either party has been guilty of certain crimes dealt with in the General Criminal Code, such as the contracting and transmitting, or exposing any others to, an infectious sexual disease, which has been contracted in consequence of immoral conduct, a serious offence against decency, or against a child under 16 or anyone being a ward of the party, incest, unnatural offences, etc.; adultery, bigamy, or such crimes as are dealt with in the Criminal Code, e.g. abduction of children and minors from the care of their parents and guardians, or a crime involving bodily injury of the other spouse, or of an deliberate crime by which the other spouse suffers injury in body or in health; or cruelty to children; or exposing them to conditions which are clearly dangerous to their morals; sentence of loss of liberty for three years or upwards; sentence to hard labour or confinement in an inebriate home for repeated acts of vagrancy or drunkenness; refusal of conjugal rights for two years; insanity for three years with no reasonable prospect of recovery; where a separation has been in existence for two years after formal decree, or for one year after such decree, if both parties assent to its becoming a decree of divorce; where there has been a separation for three years without decree, and no conjugal relations during that time (as also Report of Divorce Commission, Appendix V, pp. 43-5).

*Portugal.*—Prior to 1910, there was no law of divorce in Portugal. By Article 4 of a law passed on Nov. 4 of that year (copy set out in Appendix XXII., Report of Divorce Commission, pp. 152-3), the causes for divorce are:—(1) adultery; (2) conviction of one of the major crimes specified in Articles 55 and 57 of the Penal Code; (3) ill-treatment; (4) abandonment of home for not less than three years; (5) absence for not less than four years, during which the absentee gives no tidings of himself or herself; (6) incurable lunacy, three years after the date on which insanity has been declared by the competent authorities; (7) separation *de facto* by mutual consent for 10 years; (8) inveterate gambling habits; (9) incurable contagious disease or any disease which induces sexual aberration.

Further, by Article 34, the non-success of a suit for divorce instituted for causes 1, 2, 3, 4, 8, 9 aforesaid affords sufficient cause for the respondent in such previous actions petitioning for a divorce.

Sections 35-40 permit divorce by mutual consent, subject to the provisions laid down in those sections.

**Rumania.**—In accordance with the laws of the orthodox Greek Church, only divorce *a vinculo* is recognized, the grounds for which it may be granted being adultery; injuries or ill-treatment; sentence to imprisonment; attempt on the life of the other party to the marriage, or failure to warn such party of such attempt when made by a third party. Divorce may also be obtained by mutual consent, subject to various formalities.

**Russia.**—In Russia, before the revolution, the ordinances of each church embodied in the General Code of Laws laid down the grounds upon which divorce was to be granted.

For the members of the Russian Church, and for "the Old Believers," the grounds upon which decrees of divorce could be made were adultery; bigamy; impotence existing at marriage; the absence of the respondent for five years without news; sentence of a court of law, under which one of the parties to a marriage was condemned to loss of civil rights involving deportation; the entrance of both parties into a religious order, in cases where there are no children needing parental care; the conversion of a non-Christian spouse to the Russian Church, provided such a party or the other party to the marriage desires the dissolution. Members of the Lutheran Church (other than those resident in Finland for whom the grounds of divorce appear to be adultery, illicit intercourse with a third party after betrothal, and malicious desertion for at least one year) may seek divorce in their consistorial courts on the grounds of adultery; concealed loss of virginity of the wife before marriage; attempt to poison; five years' desertion; impotence and repugnance to marital intercourse; refusal to fulfil conjugal duties; incurable infectious disease; madness; depravity of life; cruelty and offensive treatment; attempts by one party to bring dishonour on the other or deprive him (or her) of his (or her) freedom, office, or occupation; unnatural propensities; grave crimes involving sentence of death or a punishment in substitution; penal exile. Among the Jews, divorces were granted by the rabbi. The marriage might be dissolved by mutual consent, or on grounds based on Mosaic law.

The law of Poland was, before the war, regulated by a decree of the Russian emperor of 1836, under which there were separate regulations for the members of the Roman Catholic, the Greek Orthodox, the Greek Unified and Protestant Churches, for members of denominations other than the above, and for cases where the religions of the parties to the marriage are different.

**Spain.**—No divorce is permitted.

**Sweden.**—The grounds for judicial divorces are adultery; illicit intercourse of either party with a third party after betrothal, or the intercourse of the wife with a third party before betrothal; malicious desertion for one year, provided the absentee has left the kingdom; absence without news for six years; or attempt by one party to the marriage on the life of the other; on the grounds that either party is suffering from bodily incapacity; or has concealed the fact of being affected with an incurable contagious disease; sentence of life imprisonment; insanity of three years' duration which is pronounced incurable. Divorce may also be obtained by direct appeal to the king's royal prerogative, where one party has been condemned to death or civil death; or condemned for a gross offence, or one involving temporary loss of civil rights; where one party has been imprisoned for at least two years; on the ground of prodigality, drunkenness, or violent disposition, or incurable aversion and hate, which has lasted after one year's separation *a mensa et thoro*.

**Switzerland.**—Prior to Jan. 1 1876, the different cantons of Switzerland had individual laws regulating divorce, but after that date the matter was regulated by a federal law throughout the country, and is now regulated by the Code Civil of Dec. 10 1907 which made but little change in the law then existing. The grounds laid down by that code are adultery; attempt by one party on the life of the other; cruelty (*sevices*); grave indignities (*injures graves*); the commission of an infamous crime by one party, or base conduct by one party rendering married life intolerable; malicious desertion for two years; insanity rendering married life unbearable, and which after three years' duration is pronounced incurable; conduct rendering married life unbearable. (R. Th.)

(IV.) UNITED STATES

Statistics concerning marriage and divorce are not compiled annually in the United States. The period 1867-1906 was thoroughly covered by two Federal reports, and in 1917 a government appropriation became available for continuing the investigation to the end of 1916. Because of the World War, however, it was decided to postpone the gathering of statistics for the whole decade and to make a special report for the year 1916 alone. This report was issued in 1919 by the Census Bureau. Figures for a single year may register abnormal fluctuations,

but it is apparent that divorce was rapidly increasing from the following figures for the years 1896, 1906 and 1916:—

	1916	1906	1896
Marriages . . . . .	1,040,778	853,290	613,875
Divorces . . . . .	112,036	72,062	42,937

From 1867 to 1906 the number of divorces granted totalled 1,274,341, each period of five years showing a constant increase averaging about 30%, while population was increasing at the rate of about 10%. The number of divorces per 100,000 pop. in 1916 was 112 as compared with 84 in 1906. It is noteworthy, however, that four states—Colorado, Maine, South Dakota, West Virginia—and the District of Columbia reported fewer divorces in 1916 than in 1906. The following table indicates causes of divorces in 1916, excluding 3,334 cases for which statistics were not given:—

All causes 108,702			Granted to	Granted to
			Husband 33,809	Wife 74,893
Adultery . . . . .	12,486	11.5 %	6,850	5,636
Cruelty . . . . .	30,752	28.3	5,895	24,857
Desertion . . . . .	39,990	36.8	16,908	23,082
Drunkenness . . . . .	3,652	3.4	271	3,381
Neglect to provide . . . . .	5,146	4.7	—	5,146
Combination of preceding . . . . .	9,332	8.6	1,440	7,892
Other causes . . . . .	7,344	6.8	2,445	4,899

It appears that 31.1 % of the divorces were awarded in 1916 to the husband and 68.9 % to the wife; for 1906 the percentages were 32.5 and 67.5 respectively. It is probable that the wife more frequently has legal ground for divorce. Of the total number in 1916 desertion was the most frequent ground, and cruelty next, these two causes accounting for 65.1 % of all. Of the 108,702 divorces noted in the table above, 60,036, or 63.5 %, were granted in the state where the marriage had taken place, as compared with 76.3 % for the period 1887-1906. It is not possible to determine the extent to which persons migrate to another state for the purpose of obtaining a divorce, as population is constantly shifting, but many changes of residence are made for this purpose and the tendency appears to be growing. The question of uniform state divorce laws was discussed in 1913 at the conference of governors, but the conflicting views held in different sections of the country do not point to early action. There is a growing demand, especially on the part of church authorities, for an amendment to the Federal Constitution to empower Congress through legislation to regulate marriage and divorce.

**DIXMUDE**, or in Flemish **DIXMUDE**, a town in the province of West Flanders, Belgium, on the right bank of the Yser, with a pop. which had risen from 3,278 in 1909 to 3,460 in 1914. It is the centre of an agricultural district noted for cattle-rearing and for its dairy produce. The 15th-century church of St. Nicolas had a remarkably fine wood-loft erected in the 16th century by Jean Bertet and an Adoration of the Magi by Jordaens (1644).

As a result of the World War the town was almost totally destroyed. Dixmude constituted in effect one of the principal points of passage of the Yser and, at the end of Oct. 1914, a force of 5,000 Belgians and a brigade of French marines under Admiral Ronnach successfully resisted the desperate efforts of the Germans to seize the town. The town held out until Nov. 10, by which date, by damming the lower reaches of the Yser and opening the sluices between Dixmude and Nieupoort, a large flooded area was placed between the two armies. The town was retaken by the Belgians on Sept. 29 1918. The pop., which after the Armistice had been slowly returning, numbered in 1921 about 1,000 persons, housed for the most part in temporary huts, and the rebuilding of the town had begun.

**DJEMAL PASHA** (AHMAD DJEMAL) (1875- ), Turkish politician and soldier, was born at Bagdad about 1875. His father, a person of some distinction, gave him a careful French education, and placed him in the army, where his energy and activity speedily brought him to the rank of lieutenant-colonel. As such he went to Salonika, where he spent five years, and not only gained an intimate understanding of the Young Turk ideas, but became their most able supporter. In 1900, when Djemal went as governor to Adana in Cilicia, he was charged with the task of strengthening the Young Turk ideas and the elimination of contrary currents. It was in administrative matters that Djemal's talents were most conspicuous. In 1911

he was made governor of his native town, Bagdad, but a year later he was sent to the Balkan War in command of a division, and subsequently contrived to become Vali of Constantinople.

After once more filling a military rôle for a short time as commander of the I. Corps at Constantinople, he handed over the command to the German general, Liman von Sanders, and devoted himself to politics. At that time Djemal, Talaat and Enver constituted a triumvirate which was the only effective Turkish Government, and already a certain antagonism, which had its roots in personal ambition, had sprung up between Djemal and Enver. Djemal obtained the Ministry of Public Works and immediately afterwards the Ministry of Marine. Djemal gave Adml. Limpus and the English naval mission a free hand, as Enver did the German military mission. In the spring of 1914 Djemal attended the French fleet manoeuvres, and on Aug. 9 1914, after the outbreak of the World War, he wished the home-going Frenchmen glory and victory. He was unwilling that Turkey should attach herself to Germany at once, even though the victory of the Central Powers might be certain. Enver, fearing Djemal's influence in Constantinople, banished the Minister of Marine, at the end of 1914, to Syria, as commander-in-chief of the IV. Army. There his military achievements were insignificant, but he fought the plagues of locusts and the epidemics, exerted himself over the cultivation of the land, the draining of the marshes, the building of new and the improvement of old streets, even began the work of afforestation, and made efforts to raise the level of public education. In Oct. 1917 he was removed by order of Enver from the command of the IV. Army and made commander-in-chief of all the troops in Syria, Palestine and the Hejaz, with the exception of the army operating on the Sinai front. This edict led to disorder and friction. Djemal's power was not lessened south of the Taurus, but he took no more interest in the conduct of the military operations. In Dec. 1917 he betook himself to Constantinople, and, greatly to the wrath of Enver, resumed his activities as Minister of Marine. However, he was given no more opportunities, either political or military. When, in the autumn of 1918, Turkey, and with her the Young Turk Government, was broken in pieces, Djemal Pasha was forced to flee, and he repaired to Germany where he wandered about under an assumed name. Later he obtained refuge in Switzerland, and subsequently he made his way to the East. In 1921 he was reported to have found employment as military adviser to the Amir of Afghanistan.

**DOBSON, HENRY AUSTIN** (1840-1922), English poet and man of letters (see 8.352), died at Ealing Sept. 2 1921. His later work consisted of prose essays, notably *At Prior Park* (1912), *Rosalba's Journal* (1915) and *Later Essays* (1921), all studies of the 18th century, and *A Bookman's Budget* (1917).

**DOGGER BANK, BATTLE OF.**—One of the most important naval engagements in the World War was fought near the Dogger Bank on Jan. 24 1915 between the British and German battle cruiser squadrons.

Movements of the British fleet had led the Germans to suspect some scheme for blocking their harbours was afoot, and Rear-Adml. Hipper was despatched at nightfall on Jan. 23 to reconnoitre off the Dogger Bank. His force consisted of the four battle cruisers of the First Scouting Group, the "Seydlitz" (flag), "Derfflinger," "Moltke" and "Blücher," four light cruisers of the Second Scouting Group, and 22 destroyers of the 5th Flotilla and the 15th and 13th Half Flotillas. Intelligence of the departure of the German force had been intercepted at the British Admiralty, and Vice-Adml. Sir David Beatty (later Earl) put to sea from the Fifth at 6 P.M. on the evening of the 23rd. With him were the four battle cruisers of the 1st and 2nd Battle Cruiser Squadrons, the "Lion" (flag), "Tiger," "Princess Royal," "New Zealand" and "Indomitable," and the four light cruisers of the 1st L.C.S. under Commodore W. E. Goodenough in the "Southampton." His orders were to proceed to a rendezvous in 55° 15' N 3° 12' E, 180 m. from Heligoland, where he was to meet Commodore Tyrwhitt in the "Arethusa" (flag) with the 1st, 3rd and 10th Flotillas, mustering three light cruisers and 30 destroyers. Behind him to the northward was the Grand

Fleet. The 3rd Battle Squadron (seven King Edward VII. class) had left Rosyth two and a half hours after him and the commander-in-chief had put to sea from Scapa with the battle-fleet. In the hope of intercepting the enemy on his way back Commodore (S)<sup>1</sup> had been ordered to proceed towards Borkum with the "Lurcher," "Firedrake" and four submarines. In heavy gulls the British force was decidedly superior. The British battle cruisers mounted 24 13.5-in. and 16 12-in. against the German 8 12-in., 20 11-in. and 16 8.2-in.

Beatty reached the rendezvous at 7 A.M. It was a winter morning with a calm sea and good visibility. His battle cruisers were in a single line ahead with Goodenough's light cruisers a couple of miles on the port bow. Course was altered to S. by W. at 18 knots. Ten minutes later the "Arethusa" was sighted to the south-eastward about 7 m. on the port bow. The "Aurora" and "Undaunted," the two other Harwich light cruisers, were still some 15 m. to southward of her out of sight. Hardly had the "Arethusa" been identified by the "Lion" when flashes of gunfire were seen to the S.E. This was the "Aurora" engaging the "Kolberg" coming up from the S.E. on the port bow of Hipper's squadron. The "Kolberg" was hit twice and withdrew at 7:25 A.M.

At the sound of the guns Admiral Beatty ordered his light cruisers to chase to the southward. The "Southampton" had hardly gone a couple of miles when the "Aurora" was seen on the starboard bow, and soon afterwards enemy battle cruisers were sighted on the port bow to the south-east. Dense clouds of smoke were pouring from their funnels and they were evidently going up steam for full speed. It was now ten minutes to eight. Beatty's unexpected appearance had come on Hipper as an unpleasant surprise, and he turned to the S.E. and made off at full speed with Beatty some 13 to 14 m. behind. Beatty's position at 8:30 A.M. was about Lat. 54° 30' N. Long. 3° 40' E., and the two forces had settled down to the long rush to Heligoland 140 m. away (see fig. 1). When the chase commenced the British

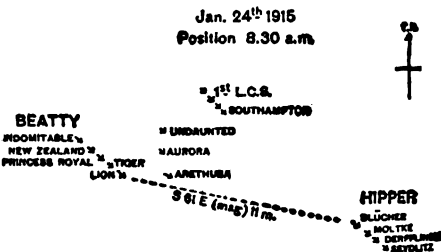

FIG. 1.

battle cruisers were in single line ahead on a S.E. by S. course working up to full speed. The "Arethusa," "Undaunted" and "Aurora" now took station about 5 m. on the "Lion's" port bow in a ragged line abreast some 2 m. apart. Goodenough with his squadron was further off on the port bow steaming hard after the enemy. Hipper was 11 m. sharp on the "Lion's" port bow on a S.S.E. course in full flight for Heligoland with his light cruisers and destroyers ahead of him sharp on his starboard bow. The action about to commence took the form of a long chase in which speed was the principal consideration. Here Beatty's squadron had a considerable margin of superiority. It maintained an average speed of probably 26 knots; while Hipper's may have done just over 23 till the "Blücher" fell out, and something over 24 afterwards. By 8:42 A.M. the range of the "Blücher" had come down to 22,000 yd., and at five minutes past nine the Vice-Admiral hoisted the signal to engage. At 9:30, some 17 minutes after the first shot, the "Lion" obtained her first hit on the "Blücher." About ten minutes later, at 9:20 A.M., a movement of some sort was observed among the enemy destroyers, and in

<sup>1</sup> Commodore (S) = Commodore (Submarines), Commodore Roger Keyes.

expectation of an attack British destroyers were ordered to take station ahead, but none of them except the "M" class had the speed to do so and the remainder accordingly dropped back to clear the range. At 9:35 the "Lion" made the signal to engage corresponding ships in the enemy's line, not intending it to refer to the "Indomitable," which had dropped some way astern, but the "Tiger" took it to include the "Indomitable," and instead of firing at the "Derfflinger," the second ship, concentrated on the "Seydlitz," leaving the "Derfflinger" unfired at. It was not till 9:45 that the Germans scored their first hit on the "Lion," sending an 11-in. through her armour aft. Five minutes later a 13.5-in. crashed into the after turret of the "Seydlitz," wrecking a portion of the stern and igniting a charge in the working chamber under the turret. The flames roared up through the turret and passed through a connecting door into the adjoining one, setting the charges alight there and turning both turrets into furnaces where all the guns' crews perished. The "Blücher" was now having trouble with her engines, and at ten o'clock drew out of the line going heavily. The range increased for a time partly due to the "Lion" slowing down to 24 knots at 9:53 to allow the line to close up, partly to the enemy turning away for a time. The "Blücher" was on fire by this time and had dropped behind to a position 3 or 4 m. on the "Seydlitz's" port quarter. At 10:22 Adml. Beatty, to bring the rear of his line into action, ordered his battle cruisers to form on a line of bearing N.N.W. and to proceed at utmost speed. But repeated hits were telling on the "Lion," and at 10:45 she was dropping back. As it was clear that she could no longer maintain her place at the head of the line, Beatty at 10:47 made a signal "to close the enemy as rapidly as possible consistent with keeping all guns bearing," but the "Tiger" was the only one to receive it and then only the words "close the enemy." About 10:50 A.M. the "Lion" received a bad hit on the port side aft, which holed the feed tank and did serious damage in the engine room. This was the crisis of the action; at this moment the wash of a periscope was seen on the starboard bow (in a position Lat. 54° 9' N. 5° 15' E.), and Beatty immediately made a signal to alter course eight points to port. This was hauled down at 11:02 A.M. and the squadron turned to N.N.E. (see fig. 2).

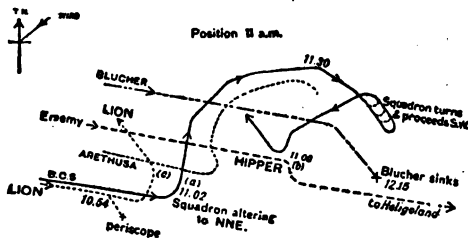

FIG. 2.

But the "Lion" was no longer able to perform the duties of a flagship. Her wireless and her searchlights were out of action, she had fallen out of line and the rest of the squadron was drawing every moment farther and farther away to the northward. The "New Zealand" was some way behind, and Rear-Adml. Sir Archibald Moore, the second in command, whose flag was flying in her, had not grasped the intention or nature of the turn.

It was urgently necessary to resume the chase. Beatty therefore ordered two signals to be made—compass B (course N.E.) and A.F. (attack the rear of the enemy), and then a third: "Keep nearer to the enemy. Repeat the signal the Admiral is now making." These all went up practically at the same time, and had they been understood in the sense in which they were made would have redeemed the situation. Unfortunately Rear-Adml. Moore only received the first two at 11:21 A.M. and then read them as meaning "attack the rear of the enemy bearing N.E." The "Blücher" was then bearing roughly N.E., and taking them as an order to attack the "Blücher" he steered

towards her. Hipper altered for a few minutes to the S., bringing a heavy fire to bear on the "Tiger," which received seven hits at this time, then resumed his course E.S.E. and drew rapidly out of range. The "Lion" in a crippled state steamed slowly to the north-westward, while the remainder of the squadron some 6 or 7 m. off began to circle round the "Blücher," whose fate was now sealed. The destroyers "Meteor" and "Miranda" attacked her, but she was still in action and sent four shots into the "Meteor," wrecking her boiler room. At 11:38 A.M. the "Arethusa" came up and fired two torpedoes into her. She ceased firing, listing heavily with fires raging fore and aft. Hipper was now some 15 m. off, only 70 m. from Heligoland, and Rear-Adml. Moore apparently did not think it worth while to continue the chase. It was not till 11:52 A.M. that he assumed active command and made his first signal to form single line ahead and steer west. Beatty meanwhile had transferred his flag to the destroyer "Attack" and was racing after his squadron. About half-past twelve he reached the "Princess Royal," hoisted his flag in her and was about to resume the chase. But pursuit was now hopeless, and the situation not too favourable. The "Lion" could only go 10 knots and the High Sea Fleet was supposed to be coming up. Accordingly at 12:45 P.M. the squadron turned back. Hipper meanwhile made for home and got in touch with the German battle-fleet about 2:30 P.M. The "Blücher" had been lost, the "Seydlitz" seriously damaged and the "Derfflinger" hit three or four times. When Beatty turned home Jellicoe was hastening down to him with the battle-fleet. They met at 4:30 P.M. and it remained only to get the "Lion" home. In tow of the "Indomitable" and screened by the 1st and 2nd Light Cruiser Squadrons and two flotillas she reached Rosyth safely the next morning.

The loss of the "Blücher" was quickly reflected in German naval policy. Adml. von Pohl took Adml. von Ingenohl's place as commander-in-chief of the High Seas Fleet with definite instructions to revert to a more cautious policy.

On the British side the results were generally regarded as disappointing. It was believed that, had the pursuit been pressed, the "Seydlitz" and "Derfflinger" might have shared the "Blücher's" fate, but it must not be forgotten that the range was still over 18,000 yd. and the enemy's speed not seriously diminished. The battle, however, had a very real result. It fettered the initiative of the German commander-in-chief, and put an end to raids on the English coast for over a year.

See also Filson Young, *With the Battle Cruisers* (1921).  
The following is a list of the forces engaged:—

BRITISH

- 1st Battle Cruiser Squadron.
  - "Lion" (flag), Vice-Adml. Sir David Beatty, Capt. Alfred Chatfield, 28 knots (designed).
  - "Princess Royal," Capt. Osmond de B. Brock, 28 knots.
  - "Tiger," Capt. Henry B. Pelly, 30 knots.
- Armament 8 13.5-in., 16 4-in. ("Tiger" 16 6-in.).
- 2nd Battle Cruiser Squadron.
  - "New Zealand" (flag), Rear-Adml. Sir Archibald Moore, Capt. Lionel Halsey, 26 knots.
  - "Indomitable," Capt. Francis W. Kennedy, 25 knots.
- Armament 8 12-in., 16 4-in.
- 1st Light Cruiser Squadron.
  - "Southampton," Commodore W. E. Goodenough, Comm. E. A. Rushton.
  - "Birmingham," Capt. Arthur A. Duff.
  - "Nottingham," Capt. Charles B. Miller.
  - "Lowestoft," Capt. Theobald W. Kennedy.
- Armament 9 6-in., "Southampton" 8 6-in., 25 knots.
- Harwich Flotillas.
  - "Arethusa," Commodore Reginald Tyrwhitt, Comm. E. K. Arbuthnot.
  - 10th Flotilla: "Meteor" (Comm. Hon. Herbert Mead), "Miranda," "Milne Mentor," "Mastiff," "Minos," "Morris," speed 34 knots.
- 3rd Flotilla: "Undaunted," Capt. Francis St. John, "Lookout," "Eysander," "Landrall," "Laurel," "Liberty," "Laertes," "Lucifer," "Lawford," "Lydia," "Louis," "Legion," "Lark," speed 29 knots.
- 1st Flotilla: "Aurora," Capt. Wilmot S. Nicholson, "Acheron," "Attack," "Hydra," "Ariad," "Forester," "Defender," "Druid," "Hornet," "Tiger," "Sandfly," "Jackal," "Goshawk," "Phoenix," "Lapwing," speed 27 knots.



## GERMAN

## 1st Scouting Group.

- "Seydlitz," Rear-Adml. Hipper, 10 11-in., 12 5-9-in., 26 knots.  
 "Derfflinger," 18 12-in., 12 5-9-in., 27 knots.  
 "Moltke," 10 11-in., 12 5-9-in., 25 knots.  
 "Blücher," 12 8-2-in., 8 5-9-in., 24 knots.

## 2nd Scouting Group.

- "Graudenz," "Stralsund," "Kolberg," "Rostock."

(A. C. D.)

**DOGS (WAR).—**That dogs could be usefully employed as auxiliaries in the prosecution of war, as was the case in the World War of 1914-8, is not a modern discovery. Both Greeks and Romans used them for offensive and defensive purposes and for maintaining communication on the field of battle. War-dogs are mentioned by Plutarch and Pliny, and Strabo describes how, in Gaul, dogs were armed with coats of mail. In the Middle Ages and in early modern history there are many stories, some of them no doubt legendary, of the participation of dogs in war. In the Crimean War, dogs were employed on sentry duty; in the American Civil War they were used both as sentries and guards.

An ancient writer, Camerarius, noted that guard-dogs could discriminate Christians from Turks; and a modern authority has stated that dogs employed during the war of 1914-8 could even detect men of unfamiliar regiments. Instinctive fidelity and keen scent power make the proper sort of dog peculiarly suitable for training as an auxiliary in war. Further, a dog very readily acquires a sense of danger, and it was noted, during the World War, that dogs, if unable to reach or uncertain of a particular destination, would make their way back to their kennels. They would never cross the zone to the enemy. The same instinct for hurrying to the rear was, it may be added, observed in stray horses and mules.

Despite his acknowledged suitability, however, no modern systematic training of the dog for use in war began until the latter part of the last century. About that time the movement made considerable headway in Germany, mainly because of the energetic championship of the animal-painter, Jean Bungartz. In France, too, some progress was made and some official encouragement extended; but in England, apart from the private efforts of Lt.-Col. E. H. Richardson, no action was taken, and it was not until 1917 that a British war-dog training school was established at Shoeburyness.

In Germany there was, at first, a great difference of opinion on the question of the most suitable breed for training. Poodles were originally decided upon, because of their high degree of intelligence, but poodles suffer considerably when exposed to the heat of the sun and, though they have sharp scent, they are extremely short-sighted. The St. Bernard was then experimented with. The record of its ancestors at the Hospice was distinguished enough; but it seemed to have been forgotten that the Hospice dog, besides being short-haired, was also of lighter build than the modern St. Bernard. The pointer was next tried; but though it has unquestionably the necessary intelligence and physical strength, the hunting instinct is so deep-rooted in this breed as to be ineradicable except after years of labour. One principle the German authorities had insisted upon from the outset—that "a military dog cannot be produced from cross-breeds." The Scotch collie, pure-bred for centuries, was, therefore, some 20 or 30 years ago regarded with great favour in Germany as a potential war-dog. J. Bungartz, indeed, in his book on the subject of the war-dog, dated 1892, pays eloquent tribute to the collie's qualities. Later, however, the collies fell into disrepute; and during the World War the great bulk of the dogs employed with the German army (it has been stated that, almost immediately after the outbreak of war, the Germans placed some 6,000 war-dogs in the field) were German shepherd-dogs. Indeed, according to the returns of the German Society for Ambulance Dogs (Oldenburg) of 1,678 dogs sent to the front up to the end of May 1915, 1,274 were German shepherd-dogs, 142 Airedale terriers, 239 Dobermanns and 13 Rottweilers. The figures remained in a like proportion throughout the war. The ambulance dogs were able to distinguish between the dead and the apparently dead; the former they left untouched, even passed

with signs of disgust, the latter they succoured. The English and French armies found it impossible to employ ambulance dogs on the western front during the late war; but the German army seems to have employed them, especially during the Russian retreat on the eastern front, with conspicuous success. It is indeed officially recorded that thousands of German soldiers owed their lives to ambulance dogs. Messenger-dogs also constituted an acknowledged part of the organization of the German army. An infantry regiment was allotted a maximum of 12 dogs, while a battalion might have six, the allotments being made by the Messenger Dog Section (*Meldhundstaffel*) at the Army Headquarters. The breeds chiefly employed for message-carrying work were German sheep-dogs, Dobermanns, Airedale terriers, and Rottweilers. The Germans, unlike the British, employed the dogs on the double-journey—"liaison" principle—that is, with two keepers, and the dog travelling backwards and forwards between both. In the British army the messenger-dog was trained to make the return journey only to the one keeper.

British war-dogs, which were placed under the signal section of the Royal Engineers, were employed principally in maintaining communication, though sentry-dogs did valuable work, especially in Salonika; but a British war-dog school was not established until 1917. Many types of dogs were used. Thus, of a total of 340 dogs sent to France from the school within a certain period, 74 were collies, 70 lurchers, 66 Airedales, 36 sheep-dogs, and 33 retrievers, the remainder being made up of 13 different breeds. A central kennel was established in France at Etaples. The training course at the school lasted about five or six weeks and the dogs and their keepers were then sent overseas. From Etaples the dogs were posted to sectional kennels behind the front line, each sectional kennel consisting of about 48 dogs and 16 men. From these kennels the dogs and their keepers in the proportion of one man to three dogs were sent up for duty in the trenches.

The war-dog training school of the French army was established at Satory about the same time as the English school was set up at Shoeburyness. Shepherd-dogs of various kinds, Airedale terriers and Scotch collies were mainly employed. Each French infantry battalion was allotted six dogs, the allotments being made from the Army Headquarters kennels. The U.S. army did not use dogs.

In determining a particular dog's suitability for war training, his physical condition should first be considered. Strength and agility combined, of course, with intelligence are in fact indispensable qualities. The chest should be broad, the legs sinewy and the parts of firm construction. Colour must also be taken into account. White dogs and those of "check" colouring are obviously unsuitable for war purposes. They would constitute too conspicuous a target. Sex, again, plays a part. A bitch in heat will, at any time, throw a pack into excited confusion and therefore, though trials have proved that bitches are apter at learning and are more trustworthy, they are not suitable for use in war. Castrated dogs, on the other hand, lack courage and temperament and are useless for work in the field. With regard to age it has been said that the dogs chosen for war training should not be less than one year and not more than four years old. (C. B. W. B.; E. S. H.)

**DOHERTY, CHARLES JOSEPH** (1855— ), Canadian statesman, was born at Montreal, Quebec, May 11 1855. He was called to the Quebec bar in 1877, and became a Q.C. in 1887. He was elected to the House of Commons for the St. Ann's Division of Montreal 1908, being re-elected Sept. 1911 and in the by-election consequent upon his taking office as Minister of Justice in Nov. 1911. He was professor of civil and international law in McGill University for several years before entering the Government. He became a member of the Unionist Government in Dec. 1917. In 1920 he was made an Imperial Privy Councillor and the same year was a member of the Canadian delegation to the first assembly of the League of Nations at Geneva.

**DOLLAR SECURITIES MOBILIZATION.**—In the British system of war finance, 1915-7, an important part was played by the mobilization of securities. During the World War enormous supplies of war materials of all descriptions had to be purchased by England from abroad, and in addition, owing to the withdrawal of labour from production in the Allied countries, abnormal quantities of goods had to be obtained from the same sources.

The exchange facilities available were entirely inadequate for the purpose of making the payments necessitated by these purchases, and artificial methods had to be adopted to provide in suitable foreign currencies the funds required. The natural procedure was by borrowing, and by the realization of such assets as were marketable in the creditor countries.

Though in some instances, and more particularly in the early days of the war, it was possible to effect loans abroad on the credit of the borrowing countries, it was found necessary to a large extent to provide collateral security in addition. The various securities quoted on the Stock Exchange and others of similar nature held in the Allied countries formed the natural and most fruitful field for obtaining suitable collateral and for providing the assets most readily marketable abroad.

Before the introduction of any official control a considerable amount of securities of the United States of America and other foreign countries was sold abroad, on account of the relatively high prices obtaining and the favourable terms on which the proceeds could be remitted home, owing to the fall in exchange rates which had already taken place. Even after the introduction of official action these natural sales continued, though necessarily in decreased volume. The funds provided by means of these sales and from loans effected abroad without collateral security supplied in the main the necessary sums to pay for the purchases made, but as the demand for goods and raw material became more insistent the British Treasury found it necessary to take official action. In July 1915 instructions were given to the Bank of England to purchase American dollar securities by private treaty or through the London Stock Exchange and forward them to New York for sale. By this means securities of the nominal value of \$233,000,000 were obtained before the end of the year and the pressing requirements of the Treasury were satisfied.

By Dec. 1915, however, it had become apparent that this somewhat haphazard method of purchasing available securities was not altogether satisfactory nor likely to achieve the desired results, and it was therefore decided to adopt a more comprehensive scheme. Accordingly, the Treasury appointed a committee, known as the American Dollar Securities Committee, with a permanent secretary of the Treasury as chairman, the deputy governor of the Bank of England as deputy chairman, and four members, two of whom were nominated by the Bankers' Clearing House and two by the Committee of the London Stock Exchange. The management was placed in the hands of Mr. (afterwards Sir) George May, the secretary of the Prudential Assurance Company.

In order to obtain some idea as to the volume and class of securities available a circular letter was sent to all the larger investors, such as insurance companies, banks and trust companies, asking them to submit lists of American dollar securities held by them, with a view to a possible sale or loan to the Treasury. Active operations were begun in Jan. 1916, at the National Debt Office in Old Jewry, by the issue of a list of 54 selected American dollar bonds which the Treasury was prepared to purchase. The prices offered were based on the current New York closing quotations of the previous evening, the New York percentage price being converted into the London sterling price at the existing rate of exchange with accrued interest.

In illustration of the procedure adopted it may be mentioned that the official prices were not only posted up at the London Stock Exchange but by a special arrangement were telephoned by the General Post-Office to all the provincial stock exchanges at about 10 A.M. This enabled the country stockbrokers to deal promptly with the committee by means of a short telegram stating the amount they wished to sell and quoting the official number assigned to the particular security. Such bargains held good provided that the telegram was handed in at the provincial post-office not later than 2 o'clock (later extended to 4 o'clock) on the day of the quotation. As regards London dealings, the bargains were booked over the counter at the National Debt Office. To facilitate delivery of securities a branch of the Bank of England was installed in Old Jewry and on the Bank's officers devolved the duty of accepting the securities in good order and paying the purchase money. It is interesting to note that brokerage was paid by the Treasury and not by the seller, while unstamped bonds were accepted on the same terms as those bearing the English stamp. In the early

days of the scheme payment was made at the seller's option in British Government Exchequer bonds then being issued. In this way the double purpose was served of obtaining the means of securing a credit in New York and increasing subscriptions for British Government securities. Additional lists of bonds and shares for which daily prices were quoted were published from time to time, while special prices were made for suitable securities not appearing in a published list. Since it was essential for the Treasury to obtain the largest possible credits in New York at the earliest possible date negotiations were entered into with large holders of securities, and bulk prices were quoted for large and comprehensive blocks.

The scheme was successful from the outset, as will be seen from the fact that securities to the value of over £40,000,000 sterling were obtained in the first ten weeks of its operation.

During the first months of the Committee's existence no securities had been taken on loan, but towards the end of March 1916 a deposit scheme, subsequently known as scheme A, was introduced. Briefly the scheme was as follows:—

Securities were to be deposited for a period of two years from the date of deposit, the lender to receive all interest and dividends on the securities deposited by him, plus an additional  $\frac{1}{4}$  of 1% per annum on the nominal amount. During the currency of the loan the lender was entitled (1) to have his securities sold in New York free of expense, the proceeds being paid to him in London at the current sterling rate of exchange, or (2) to obtain the release of his securities in New York against payment to the Treasury agent there of a sum in dollars equivalent to their American value, a similar sum in sterling being paid to the depositor in London.

The Treasury was also prepared in most instances to purchase for sterling the deposit certificates in London at the current American prices of the securities deposited. Though there was no intention to realize the deposited securities except in an emergency, the right to do so was reserved to the Treasury as otherwise the securities would have been useless as collateral for loans in New York.

In Aug. 1916 a further loan scheme, B, was brought into force. It differed from the previous scheme in that (1) deposit was for a period of five years from a fixed date, instead of two years from the date of deposit; (2) under it were included many colonial and foreign stocks and bonds in addition to the purely American securities; and (3) the right to realize securities as given under scheme A was limited to American securities having a market value in New York. Power was given to depositors under scheme A to transfer to scheme B, and this option was in most cases exercised.

The securities purchased were sold immediately a suitable opportunity offered, and those remaining unsold, together with deposited American dollar securities, were used for short borrowing as required. The main use, however, to which the deposited securities were put is illustrated by the particulars of a typical loan floated in the United States of America prior to the entry of that country into the war:—

UNITED KINGDOM 3-5 year  $\frac{1}{2}$ % Notes Dated Nov. 1 1916.

Amount of loan	\$300,000,000
Collateral	\$60,000,000
Composed of	
\$ 59,500,000	Australasian
25,000,000	South African
20,000,000	Argentine and Chilean
30,000,000	Japanese
15,000,000	Egyptian
5,000,000	Cuban
25,000,000	British Railway Debentures
180,000,000	U.S.A. dollar securities and other
	Canadian

Up to May 27 1916, rather less than five months after the formation of the Committee, the amount paid for securities purchased exceeded £51,000,000 sterling, while the nominal amount of securities deposited on loan was about £8,000,000. Since these figures, however, were not sufficient to provide the funds required, the Chancellor of the Exchequer stated in Parliament that powers would be taken to impose a special tax of 2s. in the £1 on the income of all securities that the Treasury, by means of special lists, declared its willingness to purchase. The necessary authority of Parliament was granted. Relief from the additional tax was only obtainable by selling or loaning the specified securities to the Treasury. The effect was immediate. In the first two weeks following the announcement the purchases exceeded £23,000,000 sterling and the deposits £15,000,000 sterling. In course of time the purchases greatly decreased but the deposits, mainly owing to the introduction of scheme B, assumed very large proportions. For example, during the month of Sept. 1916, the securities taken in on loan amounted to about £100,000,000. The enormous requirements of the Treasury are

emphasized by the fact that in spite of the large amounts of securities purchased and deposited a still more drastic step had to be taken.

On Jan. 24 1917, a regulation issued under the Defence of the Realm Act came into force, by which the Treasury was given power to requisition securities. The first order under this regulation was issued on Feb. 17 1917, and required owners or custodians of specified securities to deliver them up in return for an amount of compensation based on the current market values. Holders of securities not ordinarily resident in the United Kingdom and certain other holders were exempted from the terms of the order. The compensation was payable within seven days of the transfer, and power was given to reduce its amount in case of late delivery. Altogether four such orders were issued, the number of securities included being 1,076. On March 1 1918 deposit scheme B was closed to new deposits, except in regard to securities subject to the extra 2s. tax and which had not previously been included in the list of requisitioned securities. A little later, when the securities under scheme A began to fall due for return, depositors were given the option to extend the term to five years. Nearly all such depositors availed themselves of this offer.

In addition to the purchase and loan schemes which have been described above, the American Dollar Securities Committee undertook various operations for the purpose of placing dollars at the disposal of the Treasury in America. In this connexion may be instanced arrangements with various Canadian provincial and municipal authorities for the purchase of their sterling securities in London for cancellation and the issue, in place thereof, of Canadian dollar securities for sale in America. Similar plans were adopted in the case of certain American industrial companies. Further, arrangements were made with certain British corporations to issue their own loans in America and place the dollars obtained at the disposal of the Treasury, the latter looking after the American loan and providing the English company with sterling in London. As an instance, reference may be made to the issue by the Central Argentine railway of a \$15,000,000 loan in America.

The labour involved in connexion with the operations and more particularly with the loan scheme, was of considerable magnitude, and it was necessary to adopt every device in order to lessen the work, which in the main had to be carried out by a staff collected in a time of emergency. In the early days an agreement was entered into with the agents of over £100,000,000 bearer securities, the coupons of which had to be encashed in London, to pay the coupons on deposited securities, plus the additional  $\frac{1}{2}$ % per annum, and for this purpose they were supplied with schedules giving such information as would permit of the calculations and payments being made. In Sept. 1917 this procedure was discontinued, and thereafter the work was taken over by the National Debt Office.

With regard to the registered stocks on deposit, much duplication of work was avoided by the railway companies and other paying agents undertaking to keep the Treasury register and pay the increased interest as it fell due. By this means it is estimated that the authorities were relieved from the preparation, etc., of about 350,000 dividend warrants each year. Further, certain approved agents were appointed to accept deposits of amounts of less than \$5,000 each, the securities being handed over in bulk to the Committee; payment of interest on the aggregate amounts was made to such agents, who in turn distributed the sums received amongst the individual depositors.

The United States of America was naturally the chief source of supply, both for munitions of war and for goods, and therefore the financial arrangements already referred to were mainly directed to the provision of dollars in order to effect the necessary payments. In a smaller degree, however, payments had to be made to other countries, and certain of the securities obtained by the Committee were used to meet these obligations.

The United Kingdom was, of course, preminent as the holder of foreign securities, and she therefore played by far the greater part in the efforts made towards mobilization in the Allied interests. But France also held a considerable amount and had a deposit scheme of her own, though on nothing like the same scale as that of the United Kingdom. In her scheme no purchases of securities were made, but a considerable volume of private sales to the United

States of America was effected, both direct and through London, and to a certain extent purchases of French holdings were made by the American Dollar Securities Committee through the medium of the banks of France and England.

The total amount of securities dealt with under the British mobilization scheme, including those bought by the Bank of England prior to the appointment of the American Dollar Securities Committee, was as follows:—

Purchases . . . . .	£216,000,000
Deposits . . . . .	£406,000,000
Total . . . . .	£622,000,000

These particulars may be to some extent amplified. Thus the purchases consisted of:—

\$680,000,000 . . . . .	Dollar bonds
\$241,300,000 . . . . .	Dollar shares
£ 27,800,000 . . . . .	Sterling bonds and shares
£ 4,100,000 . . . . .	Registered stocks
Fl. 5,400,000 . . . . .	Florin bonds and shares

Similarly the deposited securities were made up of:—

\$197,800,000 . . . . .	Dollar bonds
\$303,600,000 . . . . .	Dollar shares
£115,100,000 . . . . .	Sterling bonds
£172,000,000 . . . . .	Registered stocks
£ 17,500,000 . . . . .	Home Railway debentures
Fr. 5,500,000 . . . . .	Franc bonds
Kr. 8,100,000 . . . . .	Kroner bonds
Fl. 4,400,000 . . . . .	Florin bonds

The total number of different securities dealt with was 2,027.

The total amount of American dollar securities which passed through the hands of the Committee was thus approximately £285,000,000. In addition securities to the value of probably £1,000,000 were sold direct to America through the ordinary channels making in all, say, about £400,000,000. Various estimates have been made from time to time of the amount of American securities held in Great Britain before the war. The data available on which to base any such estimate are very vague and uncertain in their nature, and the present writer is inclined to believe that any such estimate can only be regarded as more or less intelligent guessing. In his opinion the total amount of American securities held in Great Britain before the commencement of hostilities was certainly greater than £600,000,000 and probably nearer £500,000,000.

The operations of the Committee undoubtedly achieved the purpose for which it was formed, as during its existence the rate of exchange practically remained constant at about 4.76½ dollars to the £1. Although securities were purchased and taken on loan after the Americans came into the war the amounts obtained were not great, and it is believed that practically all available American securities suitable for sale or collateral for loans had been dealt with.

It is difficult to see what course could have been taken in order to obtain the necessary credits abroad in sufficient amount when these securities had been exhausted, but speculation on this point would be idle since the necessary credits became available after and on account of the entry of the Americans into the war. (G. E. M.)

**DOLLAR STABILIZATION.**—Under the existing currency system, the so-called "level of prices" is largely at the mercy of monetary and credit conditions. The tide of prices will rise or fall with the flood or ebb of gold or of paper money or of bank credit. Evidently a rise in the level of prices is a fall in the purchasing power of the dollar or other monetary unit, and *vice versa*. The purchasing power of money has always been unstable because a unit of money, as at present determined, is not a unit of purchasing power, but only a unit of weight. It is the one inconstant unit of measurement left in civilization. Other units—the yard, pound, bushel, etc.—were once as unstable and crude as the dollar, sovereign or franc still are; but, one after another, the other units have all been stabilized or standardized. Short weights and measures cheat the buyer; long weights, the seller. So a unit of money which changes in value or purchasing power is always playing havoc between contracting parties. When prices are rising—in other words, when the purchasing power of the dollar is falling—the creditor and the creditor-like classes suffer injustice. The sufferers include savings-bank depositors, bondholders, salaried classes and wage-earners. In the great upheaval of prices—i.e. in the United States, depreciation of the dollar—which took place between 1896 and 1922 such injustice amounted to over a hundred billion dollars. On the other hand, when prices fall, as they did between 1873 and 1896, it is other classes—debtors, stockholders, farmers and independent business men generally—which suffer the injustice. The indirect effects of falling or rising prices—i.e. of a rising or falling dollar—are equally bad. These indirect effects include industrial discontent

(either over the "high cost of living" or unemployment) and economic crises and depressions.

Hitherto there was ample excuse for the unstable monetary units of various countries. No instrument for measuring their aberrations had been devised. Likewise, until weighing scales were devised, weights could not be standardized, and until instruments for measuring electrical magnitudes were invented, electrical units could not be standardized. But for many years the "index number" of prices has provided an accurate instrument for measuring the value of the dollar in terms of its power to purchase goods. An "index number" of prices is a figure which shows for a specific period of time the average percentage increase or decrease of prices. One of the most suggestive signs of the times is that this instrument for measuring changes in the purchasing power of money has recently been utilized in adjusting wages and salaries to the high cost of living, *viz.* to the depreciated dollar. A number of industrial concerns and banks, and some official agencies, have amended wages by the use of an index number of the prices of commodities.

It has been contended by some economists that this principle may be utilized in the future more generally to safeguard agreements made at one date to pay money at another date. Such corrections of the dollar would gradually break down the popular superstition that "a dollar is a dollar"; for every time we correct the dollar, we convict it of *needing* corrections; and ultimately the correction might be applied, not, as at present, as a patch on the dollar from the outside, but by incorporating it in the dollar itself. Various methods for accomplishing this have been proposed. The one perhaps best known is Prof. Irving Fisher's proposal to vary the weight of the gold dollar so as to keep its purchasing power invariable. Instead of a gold dollar of constant weight and varying purchasing power, what is needed, he contends, is a dollar of constant purchasing power, and, therefore, of varying weight. It is not proposed, of course, to re-mint gold coins, but simply to count an ounce of gold bullion as being the equivalent not always of \$20.67 (as at present) but of as much more or less than that sum as is required from time to time in order to keep the purchasing power of the dollar constant. In other words, the proposal is to vary the price of gold according to its worth relative to other commodities, instead of, as at present, keeping it artificially constant at \$20.67 an oz. pure or £3 17s. 10½d. an oz. 11/12 fine. In this way, Professor Fisher contends, we can control the price level, lowering it, raising it, or keeping it from fluctuating much, if at all. Thus, if Mexico should adopt the dollar of the U.S. (instead of its present dollar of half the weight of gold), the price level in Mexico would be disastrously cut in two. Again, if the U.S. should adopt the Mexican dollar, the price level in the U.S. would be disastrously doubled. That is, the more gold in the dollar, the greater its buying-power; and the less, the less. If, Professor Fisher contends, this principle be admitted, it follows that we hold, in the hollow of our hand, what the dollar's buying-power shall be—that is, what the level of prices shall be. It can be kept from changing greatly just as easily as it could be made to change, simply by periodical adjustments of the price of gold, each adjustment being made in accordance with the index number of prices. By this method, in conjunction with any of the sound systems of banking, Professor Fisher contends, variations of more than one or two per cent could easily be prevented except under the most extraordinary conditions. (I. F.)

**DONALDSON, SIR JAMES** (1831-1915), British scholar (see 8.406), died at St. Andrews, March 9 1915.

**DONNAY, CHARLES MAURICE** (1859- ), French dramatist (see 8.417), wrote several fresh plays after 1910: *Le Ménage de Molière* (1912); *Les Éclaircuses* (1913); *L'Impromptu de Paquetage* (1916); *Le Théâtre aux armées* (1916). He also published some war-time essays and addresses: *La Parisienne et la Guerre* (1916); *Premières Impressions après* (1917); *Lettres à la Dame Blanche* (1917); *Pendant qu'ils sont à Noyon* (1917); *La Chasse à l'Homme* (1919).

**DOUGHTY, CHARLES MONTAGU** (1843- ), British explorer and writer, was born in 1843, the youngest son of the

Rev. C. M. Doughty of Theberton Hall, Suffolk. In 1875 he made an adventurous journey through northern Arabia, remaining nearly two years in the country, and, after many hazards and hardships, finally emerging at Jidda (see 2.257). He published the results of his observations in a work since recognized as a classic worthy to rank with the records of the Elizabethan voyagers, *Travels in Arabia Deserta*, issued by the Cambridge University Press in 1888, received at first little recognition, and brought its author no material reward. But gradually its fame spread amongst travellers and lovers of literature until the rare copies of the first edition were scarcely procurable at any price, and in 1922 a facsimile reprint of the two volumes was issued at £9 9s. The value of Doughty's work as a traveller had by that time secured universal recognition; nothing was left for any future explorer to study between Damascus and Mecca which Doughty had not already closely studied, and in 1912 the Royal Geographical Society bestowed on him its Founder's gold medal. He had done other work previously, and he published several volumes; but he remains, in the estimation of the literary world, the author of one book. It should, however, be noted that in 1866 he brought out *On the Jostedal-Brae Glaciers in Norway*, and a collection of inscriptions copied by him in Arabia was published by the Académie des Inscriptions et Belles-Lettres in 1884. His later years were devoted to poetry and poetic drama. In 1906 he published an epic in six volumes *The Dawn in Britain*, followed by *Adam Casti Forth* (1908), *The Cliffs* (1909), *The Clouds* (1912), *The Titans* (1916) and *Mansoni, or the Riddle of the World* (1920).

**DOVER**, England (see 8.453).—Pop. (1911), inclusive of the garrison, 43,645; estimated civil pop. (1920) 41,408. The municipal boundaries were extended in Nov. 1921 so as to include an area of about 70 ac. in the River Ward destined for housing purposes; at the same date the various piers and jetties of the harbour were brought within the municipal area. A new general post-office was completed in Biggin St. in 1914. Two new churches have been erected—Charlton church, a large building in the early English style which takes the place of a small church dating back to the Middle Ages since demolished, and St. Barnabas church, built between 1890 and 1912. The Duke of York's Royal Military School was transferred from London to Dover in 1907, an extensive series of buildings of the bungalow type having been erected on the Eastern Heights near Fort Burgoyne. The Connaught barracks near the castle with accommodation for an infantry battalion were completed in 1915. The Dover Patrol memorial obelisk on the cliffs E. of the town was unveiled by H.R.H. the Prince of Wales on July 27 1921.

The Dover harbour scheme—in addition to the construction of piers and a breakwater to enclose the Admiralty harbour with a perimeter of about 4½ m., completed in 1906—included the reclamation of about 11½ ac. upon the harbour (eastern) side of the Admiralty pier, to provide for a new marine station and berths for the continental mail packet steamers and other vessels. Both these projects were sufficiently completed in time to be of service during the World War.

The reclamation wall is 2,260 ft. long, and the landing-stage upon the Admiralty pier extension, 792 ft. long and 20 ft. wide. Altogether six berths are provided. The stage is built on open pile work and double decks to suit levels for the passenger steamers—spring tides rise 18 ft. 9 in., neap tides 15 ft., and range 11 feet. Reinforced concrete piles support the foundations of the passage to an inset landing-stage, and also the foundations of the marine station. At the outer end is a lighthouse 85 ft. above high-water level, the light visible for 14 miles. As at Chatham, large cranes drawing four fathoms can berth alongside the pier to unload into railway trucks.

To provide railway communication to the Prince of Wales' pier, and to the harbour quays, the Harbour Board, in 1904, constructed a new swing bridge to carry passenger trains as well as ordinary vehicular traffic; during the war this bridge proved indispensable in the transport of material.

The Harbour Board acquired parliamentary powers, in 1920, to construct, by arrangement with the Government, an enclosed wet-dock upon the Admiralty harbour side of the Prince of Wales' pier, having an area of 21 ac. and depth of 34 ft. at high-water of spring tides. The entrance lock is to be 100 ft. wide, and additional quays, transit sheds, coal-tips, and connexions to the inner dock basins will be provided.

On its completion, the Admiralty harbour became the base of the battleships and armoured cruisers of the Atlantic Fleet. In 1911 the defence of the Straits was handed over to the destroyers and submarines and a camber in the northern corner of the harbour was completed for them just before war broke out. In Aug. 1914 the Sixth Flotilla of destroyers and submarines formed the naval force guarding the Straits, with their base at Dover.

During the war Dover was entrenched, the perimeter being nearly 6 m., and a division of troops manned the defences. The Swingate aerodrome was an instructional school for the final training of officers before leaving for France, and the Guston aerodrome the H.Q. of the R.N.A.S., afterwards the R.A.F. Dover was subjected to repeated air raids, the first raid on England taking place at Dover on Dec. 24 1914. There were several Zeppelin raids in 1915-7, but the defence prevented any serious damage. In all, 184 bombs were dropped on the borough and 370 in the immediate vicinity, and the total death toll was 25. The castle was hit several times by bombs but beyond a few chips in the walls of the keep no trace of damage remains. Over 100 men lost their lives in the blowing up of the monitor "Glatton" in Dover harbour on Sept. 16 1918, and 155 were drowned in the mining of the "Maloja" off Dover on Feb. 24 1916.

At the close of the war Dover harbour was abandoned as a naval base, the camber was leased to a private company for the breaking up of old battleships, and the Admiralty in 1921 were offering to lease the naval harbour for commercial purposes.

Dover castle has been placed in the care of the Office of Works as an ancient historical building and a considerable amount of restoration and preservative work has been carried out on the Roman pharos and the late Norman towers and walls. In recent years many tiles bearing the letters CI Br have been found in the area between the Western Heights and the Dour, indicating that Roman Dover occupied this site. The tiles show from their stamp that they were made by artisans belonging to the Roman British fleet. As they have not been found elsewhere except at Boulogne, they appear to indicate that Dover was the chief Roman port to the continent.

The chief feature of the industrial development in the district was the opening up and working of the Kent coal-field. The H.Q. of the chief colliery company is at Dover.

AUTHORITIES.—"The Port of Dover," *Jour. of the Royal Society of Arts* (April 15 1910); *Engineering Supplement of the Times* (April 24 1914); J. Bavington Jones, *The Annals of Dover* (1916).

DOWDEN, EDWARD (1843-1913), English writer (see 8.456), died at Dublin April 4 1913.

See his *Letters*, edited by E. D. and H. M. Dowden (1914).

BOYLE, SIR ARTHUR CONAN (1859- ), English novelist (see 8.461), was one of the originators of the Volunteer Corps during the World War, the first corps being formed by him at Crowborough, Sus., in Aug. 1914. In this, the 6th Sussex Batt., he served for four years as a private. He also did much propaganda work, and issued various pamphlets on war subjects, also a six-volume history of the war which was extensively read in America. He visited the war zones twice, and published *The British Campaign in France and Flanders, 1914* (1916) and *A Visit to Three Fronts* (1916), as well as a volume of verse, *The Guards Came Through, and other Poems* (1919). His other writings since 1920 include *The Case of Oscar Slater* (1912); *The Poison Belt* (1913); *Danger* (1918) and *His Last Bow* (1918). He became an ardent spiritualist and published *A New Revelation* (1918) and *The Vital Message* (1919), following these up by an active campaign of lecturing and controversy on the possibility of proving by spiritualism the continued existence and conditions of human life after death. A public debate between him and Joseph McCabe on the subject took place in 1920.

DRAMA (see 8.502).—The decade 1910-20 was one of paramount importance in the history of English drama and the English theatre. Apart from the temporary, but substantial, effect of the World War, which lasted for nearly half of the decade, other causes of wide influence profoundly affected both

the drama as a part of literature and the theatre as a commercial organization during that period. In the United Kingdom great changes in the constitution of theatrical enterprises were brought about abruptly and almost catastrophically. The government of the theatre by actor-managers ceased with dramatic suddenness and was replaced by the government of syndicates composed, for the most part, of persons innocent of all knowledge of acting or drama and concerned primarily, if not exclusively, with the production of large profits quickly returned. In those theatres where the actor-manager was not replaced by a commercially minded syndicate, his place was taken by what may be called the producer-manager.

The three great actor-managers of the English theatre, Sir Herbert Beerbohm Tree, Sir George Alexander and Sir Charles Wyndham, did not outlive their reign; the era of the actor-manager ended simultaneously with their decease. Tree died July 2 1917; Alexander March 16 1918; and Wyndham Jan. 11 1919. The normal process of nature, whereby one generation or tradition is slowly merged in another, was in their case mercifully suspended. In 18 months the actor-managerial system, which had been immensely powerful, was in ruins, and its chief protagonists, men of ability and taste, were dead, spared from the humiliation of neglect and supersession. It was a system undeniably disadvantageous to the drama as an art, since it tended to make the play subordinate to the player and restricted many dramatists to the production of plays with good parts for particular persons, but there is no doubt that the actor-manager, especially the three named, were possessed of ambition and good taste and that they worked successfully to restore dignity to the theatre. They were directly associated with many of the most interesting plays that were written during their reign, and Tree, Alexander and Wyndham could claim exemption from the charge so frequently and justly brought against Sir Henry Irving, of doing nothing whatever to encourage the work of meritable modern English dramatists. Sir Herbert Tree's annual Shakespearian festival, held often at grave financial disadvantage to himself, was a real tribute to taste and culture, despite the serious complaints fairly made about his methods of production. Sir George Alexander, more than anyone else, made the way to the stage easy for the writer of distinguished comedy and was chiefly responsible for the career as a dramatist of Oscar Wilde. Sir Charles Wyndham, less consistently ambitious than his colleagues, followed an honourable tradition and was responsible for the redemption of farce from buffoonery.

The decline and fall of the actor-managerial system coincided with the disappearance from the centre of London of the music-hall in which a succession of "turns," sparsely produced but highly individualized and having no relationship with each other, formed the programme. Three well-known music-halls ceased between 1910 and 1920 to be music-halls. These three, the Oxford, the Tivoli and the London Pavilion, were the centre from which radiated an elaborate ganglion of music-halls throughout Great Britain and Ireland. The Tivoli was demolished and its site remains, in 1921, unoccupied. The Oxford became, during the war, a theatre and in 1920, under the management of C. B. Cochran, was re-named the New Oxford, where an elaborately produced but less highly individualized form of music-hall entertainment, roughly connected in shape, was provided. At the London Pavilion, also controlled by Mr. Cochran, a skillfully contrived form of what is called "revue" became the standing entertainment. Specific reference to "revues" will be made later, but here it may be said that they are not "revues" in the French sense, a commentary on contemporary affairs, but a mingling of musical comedy and music-hall entertainment in which individual ability is made subordinate to general impression. The chief characteristics of this new entertainment, seen perhaps at its best in the roof-garden productions in New York, are expensive dresses, handsome scenery, fine and even beautiful effects both in grouping and lighting, and a particular insistence on feminine beauty.

This change in the character of the London West End music-hall coincided with the great growth in popularity of the cinema,

or picture-palace, or "movies." During the decade, almost all of the London suburban theatres became picture-palaces. Many of the provincial theatres, especially in small towns, also became picture-palaces. A variety of reasons caused this change to take place, some of which were financial and others connected with altered taste. The kinemas were at once cheaper and more comfortable than the theatres and they offered a more consistently attractive programme. The inhabitants of a London suburb or a small provincial town were able to see as good a film at the local kinema as could be seen in a kinema in the centre of London, but they could not hope to see a play performed at the local theatre by a company as capable as that acting in the same play in the West End. On the contrary, they might expect with certainty to witness a very inferior exhibition of acting. Precisely the same process was observable in America, where, owing to the competition of the "movies" and the inferior quality of travelling companies, what were known as "one-night stands" ceased to be profitable enterprises and were almost entirely abandoned.

Those were the three main changes in the nature of theatrical entertainment during the decade 1910-20; the disappearance of the actor-manager and the substitution for him of the commercial syndicate; the disappearance from the centre of London of the music-hall of marked personality and the substitution for it of the music-hall with elaborate effects and mechanical skill; and the collapse of the suburban and provincial theatre before the advancing kinema. These changes, although they hardly cause satisfaction, are of the nature of constructive changes, and they probably possess permanent characteristics. The commercial syndicate may result in more efficient administration in the theatre and a greater likelihood of continuous employment for the actor. It has not yet shown a desire to produce drama equal in merit to that produced by the actor-manager, but the system is still young and it was considerably handicapped by its inauguration during the war and remains handicapped by the high cost of production. The great virtue of these syndicates is likely to be of an administrative character. Many theatres, in London and the provinces, are coming under the control of a single syndicate, and this trusteeship of theatres will enable a particular firm to arrange its tours on a more economical and comfortable system than has hitherto been the case. The old individual system unavoidably resulted in touring companies sometimes spending a week in Edinburgh, the next week in Bristol and the third week in Newcastle-upon-Tyne. In a properly organized theatrical system, such tours will no longer take place, but will be arranged so that the journey from town to town will be short and easily accomplished by motor-car or lorry.

The change in the music-hall has brought about a great development of the mechanical and pictorial side of that entertainment, and if some of the spirited personality of the superseded form can be captured for the new form, the change will be of considerable value. The danger of it is that human qualities are subordinated to machinery and spectacular effects. In the case of the kinema development has been progressive and is likely to continue so. Film-manufacturers are constantly engaged in experiment, and they will in time invent a machine which will enable them to exhibit pictures in three dimensions, in natural colours and with some effect of the human voice. This will be done by means of an instrument which is a combination of gramophone and stereoscope, aided by some process of colour-photography. The film-firms, particularly in America, are endeavouring to improve the quality of the film-play and, since they offer very handsome monetary rewards to authors, are likely to succeed in their attempt. Many of the most distinguished dramatists of the world are engaged in writing scenarios for the "movies," and several of them have announced that they will in future write only for them.

*Repertory Theatres.*—The survey in the earlier article (see 8.475) ended at a period when, in spite of many undesirable things, the drama was in a healthy condition. Plays of merit were being written and produced, not only in London, but also in the provinces where the activities of the repertory theatres were stimulating the imagination of young authors. Conservative managers were receiving original work with less hesitation or hostility than had been accorded

to it for several generations. The long and, in many respects, valuable domination of the theatre by dramatists such as Sir Arthur Pinero and Henry Arthur Jones, was declining before the rising authority of such dramatists as Bernard Shaw and John Galsworthy. The repertory theatres were increasing in number. In 1910, there were three repertory theatres in the British Isles, one in England (the Gaiety theatre, Manchester, owned by Miss A. E. F. Horniman), one in Scotland (the Abbey, directed by Lady Gregory and W. B. Yeats). The last was the oldest as it has proved to be the most durable of the three. In addition to these three repertory theatres, there was a most ambitious attempt to establish one in London, at the Duke of York's theatre, where the late Charles Frohman (who was drowned in the "Lusitania" when it was torpedoed by the Germans May 7 1915) enlisted the services of Harley Granville-Barker and Dion Boucicault. The scheme was to establish a repertory theatre more nearly corresponding to the strict definition of one than any of those operating in the provinces, which were identical with what used to be called "stock" companies. Mr. Frohman's gallant enterprise failed. It lasted for 17 weeks, from Feb. 21 to June 17 1910, and during that period eight new plays and two old ones were produced. The names of the plays and their authors are as follows:—*Justice* by John Galsworthy; *Misalliance* by Bernard Shaw; *Old Friends* by J. M. Barrie; *The Sentimentalists* by George Meredith; *The Twelve-Pound Look* by J. M. Barrie; *The Madras House* by H. Granville-Barker; *Helena's Path* by Anthony Hope and Cosmo Gordon-Lennox; *Chains* by Elizabeth Baker; *Trevelyan of the Wells* by A. W. Pinero and *Praxelles* by H. Granville-Barker and Lausman. Three of these plays were in one act (the third, fourth and fifth in the list).

The original scheme, of a strictly repertory theatre similar to the Comédie Française, was not maintained, nor does the history of the repertory theatres in Great Britain and Ireland indicate that such a scheme is ever likely to succeed in a country where the people are disinclined to make the research through newspaper advertisements which a programme of irregular performances involves. For good or ill, the system of continuous performances has obtained a hold on the British theatre which will not easily be shaken off and may never be shaken off. *Trevelyan of the Wells*, the most popular of the plays produced during the season, was performed 42 times in a season of 17 weeks, which clearly signifies that the promoters of the scheme had to revise their plan, partly to satisfy the public demand and partly to recoup themselves for the losses sustained on the unpopular pieces. A similar history has attended the establishment of other repertory theatres on Comédie Française lines in England, for example the Everyman theatre at Hampstead, established in 1920 by Norman MacDermott. The repertory theatres steadily increased in number until, at the outbreak of the World War, there were seven of them operating regularly and a number of others operating for short periods during each year. None of these theatres earned large sums of money. Some of them, indeed, were constantly embarrassed by insufficient funds. But they performed a most valuable service to young actors and young dramatists: to the first, by giving them continuous and varied employment which, although not highly remunerated, enabled them to become accomplished in their craft; to the second, by giving them the greatest of all instruction to a dramatist, the public performance of his work, and by bringing before them the work of established dramatists, British and foreign, which otherwise they would not have known except in book form. Ibsen, Strindberg, Hauptmann, Schnitzler, Maeterlinck, Rostand, Verhaeren, Sudermann, Tolstoy, Chekhov, Shaw, Galsworthy, St. John Hankin, Granville-Barker, Arnold Bennett and John Masefield among the moderns; and Euripides, Shakespeare, Ben Jonson, Congreve, Beaumont and Fletcher, Goldsmith and Sheridan among the classics—the work, in quantity, of all these writers was brought to the knowledge and even to the intimacy of provincial playgoers who, but for the repertory theatres, would have had no subsist in their lives save the more popular of the pieces produced in London and sent on tour. A similar service is performed in America by what are called "little" or "community" theatres. Out of these repertory theatres came a number of young dramatists, many of them resident in the city in which their plays were first performed, of whom at least one man was a genius, John Millington Synge (d. 1909) and three men of distinction, Stanley Houghton (d. 1913), John Drinkwater (b. 1882) and Lennox Robinson (b. Oct. 4 1886). Synge has been the subject of several biographies of which the principal and most authoritative one is *John Millington Synge and the Irish Theatre* by Maurice Bourgeois. He wrote six plays, a book of poems and translations and some impressionist articles of a newspaper character. Two of the plays are in one act, *In the Shadow of the Glen* and *Riders to the Sea*. The latter is commonly regarded as the best of his work. One of the plays, *Deirdre of the Sorrows*, is unfinished. Of the remaining three, *The Tinker's Wedding* (in 2 acts), *The Well of the Saints* (in 3 acts) and *The Playboy of the Western World* (in 3 acts), the last-named is the most widely known, partly because of its merits, but chiefly because of the anger which it aroused among the more sentimental of the Irish people who, accustomed to the romantic delusions in which subject or oppressed peoples live, could not endure the romantic realism of this play. A long succession of poets had insisted on one aspect of the Celtic



character, its idealism and generosity and romance, with the result that people disbelieved in the other aspect of it, the cruelty and greed and treacherous materialism. Sygne, a man without possessions or creed, set down what he saw in words of acrid beauty, and the Irish people, horribly shocked, pronounced him to be a liar, a degenerate and even a traitor. The violence of their anger against *The Playboy of the Western World* died down in time, but Sygne remains a man of genius of whom his countrymen, when they take pride in him at all, remain reluctantly proud. He and Lennox Robinson are the principal products of the Abbey theatre, Dublin, which includes among its minor dramatists Lady Gregory, William Boyle, T. C. Murray, Padraic Colum, the late Seumas O'Kelly and St. John Ervine. W. B. Yeats has written plays for the Abbey theatre, but the dramatic form is intractable in his hands.

Lennox Robinson, who was appointed manager of the Apley theatre in 1910, at the age of 23 and, except for a break of two or three years, has managed it ever since, has written nine plays, of which two, *The Lost Leader* and *The White-headed Boy*, have been successfully performed in London. The first was produced at the Court theatre June 10 1919, where it was acted 68 times. The second was produced at the Ambassadors' theatre Sept. 27 1920, and was acted for more than 300 times. His plays conform more closely to the conventional shape than do those of John Drinkwater, and they are more skilfully contrived than those of Stanley Houghton. He puts realistic, rather than romantic, speech into the mouths of his people, thus separating himself very distinctly from the Sygne drama. His principal merits are great technical skill, veracity of character and speech, and natural exploitation of natural emotions. His defects are a lack of staying power and vagueness of thought, which causes his last act to drop considerably below the level of his first. But of all the Irish dramatists, he has the greatest comprehension of the theatre.

Stanley Houghton, after writing a number of meritable pieces of uninspired realism, presented the Gaiety theatre, Manchester, with a comedy in three acts, entitled *Hindle Wakes*, which, to fill an emergency, was first performed before the Stage Society June 16 1912. It made an immediate impression and was put into the evening bill at the Playhouse and afterwards at the Court, receiving in all more than 100 performances in London. It had greater success in the provinces, where at least one company has performed it ever since, but it failed to be popular in America. *Hindle Wakes* is not a profound play, nor has it conspicuous literary qualities; but it is fresh and forcible and it deals with a question of sex in a direct, natural and sincere, but unusual, manner. Whether or not Houghton would have grown into a dramatist of distinction (he was 32 when he died) is not a matter which can profitably be discussed. The plays which came after *Hindle Wakes*—*The Perfect Cure* and *Trust the People*—did not sustain the reputation it had made for him, but as they seemed to be written deliberately for commercial purposes and failed to realize them—*The Perfect Cure* was performed for four nights only—it is probable that Houghton would have returned to the milieu in which he was happiest and that, although he was unlikely ever to become a first-rate dramatist, he would have become a very competent and meritable one. The Gaiety theatre, Manchester, gave opportunity to a number of other dramatists, of whom the principal are Harold Brighouse and Allan N. Monkhouse, the first-named being the author of *Hobson's Choice*, which had great popularity in America and London, and the second-named the author of *Mary Broome* and *The Education of Mr. Surragé*.

John Drinkwater is the product of the Birmingham Repertory theatre (founded in 1913 by Barry V. Jackson) of which for several years he was both manager and play-producer. He had already earned reputation as a poet, critic and dramatist when his historical play in five scenes, *Abraham Lincoln*, was first produced. This play, influenced by the form of Thomas Hardy's *The Dynasts*, is written in prose, but the scenes are separated by a Chorus who speaks in verse. It was produced for the first time at Birmingham Oct. 12 1918, and afterwards at the Lyric, opera house, Hammer Smith, Feb. 19 1919, where it was performed for exactly one year. Much doubt was felt about the reception the play was likely to receive in America, but this doubt was dispelled when, Dec. 15 1919, it was produced at the Cort theatre, New York, where it was continuously performed for nine months. *Abraham Lincoln* will probably be performed throughout the United States for many years and has given a great impetus to the production of serious historical plays in America. Percy Mackaye, an American poet, wrote a pageant play on George Washington, at the request of President Wilson, but this piece was not a success when produced in New York. Other plays on Lincoln have been written since the production of Drinkwater's play, but the latter, which was derived, so far as its main facts are concerned, from Lord Charnewood's biography of the great President, is indisputably the best of them. The play is simply and directly written, in spite of its remarkably long cast, and its emotional quality is very high. Part of its appeal to the British people is probably due to the fact that Drinkwater with extraordinary skill has unobtrusively drawn a parallel between the circumstances of the Civil War and the World War, and many of the great crowds who saw it performed in London must have been more conscious of the war from which the world had just emerged than they were of

the war which had been so fiercely fought in America 60 years earlier. This was the first of a series of historical plays planned by Drinkwater, of which two others, *Oliner Cromwell* and *Mary Queen of Scots*, have already been written. The latter was produced for the first time at the New Ritz theatre in New York March 21 1921, with Clara Eames in the title part. It is interesting to observe that Lennox Robinson and John Drinkwater have followed faithfully in the footsteps of such dramatists as Shakespeare, Molière and Ibsen by being practical theatre managers and producers and even, as in Drinkwater's case, an actor.

*The "Intellectual" Drama.*—The record of the English repertory theatres up to the time the World War began was honourable and promising. We have now to consider the record of the ordinary commercial theatre, and here we discover that the standard of plays produced had been greatly raised. The authority of Sir Arthur Pinero and Henry Arthur Jones, already diminished by the work of Oscar Wilde, was now yielding to that of Shaw and Sir James Matthew Barrie and John Galsworthy. A number of young dramatists of varying quality were appearing, whose allegiance was more definitely given to the school led by Shaw than to the school led by Sir Arthur Pinero, and these included Granville Barker, the late St. John Hankin (d. 1906), Charles McEroy, Arnold Bennett, John Massfield, Cicely Hamilton, Githa Sowerby and Elizabeth Baker. What was called the "intellectual" drama seemed to be established not on a broad basis, but on a basis sufficiently wide to make it steady. Shaw and Bennett were even able to obtain long "runs" for their plays, and Cicely Hamilton made a popular success with *Diana of Dobson's*. It is true that the "intellectual" drama did not make fortunes for its producers, but it is true also that it did not cause any bankruptcies, and probably, if an accurate statement of accounts could be prepared, the "intellectual" drama would be found to have caused less loss of money, relatively and absolutely, than the commercial drama. It might even be found to have paid its way. Following on the heels of the "intellectual" dramatists cited above came still younger dramatists, also of the school led by Shaw, whose intellectuality was perhaps less arid or severe, and these young dramatists contrived to write plays definitely of the "intellectual" school which made much profit for those who produced them. They have already been named in connexion with the repertory theatres. Their lack of aridity is due, possibly, to the fact that the stage is their first concern, whereas most of the generation between them and Shaw came to the theatre from the novel and the sociological survey.

Outside the "intellectual" or "highbrow" school, in what is called the commercial theatre, there was observable a great increase in the quality of the plays produced. The younger dramatists who were without any intellectual pretensions were indirectly affected by the work of Shaw, even when it was repudiated by them. Plays by Hubert Henry Davies, Rudolf Besier, Alfred Sutro, Bernard Fagan, Somerset Maugham and J. E. Harold Terry were notably better in quality than plays written by their predecessors at any time during the century immediately preceding their appearance in the theatre. The work of Besier in *Don* and *Lady Patricia* had a flavour of letters and a technical excellence which made it appear almost equal to the best work of Sir Arthur Pinero and Henry Arthur Jones and superior to the best work of Sydney Grundy. Somerset Maugham, who began his career with a sombre play, *The Man of Honour*, changed his *métier* completely and very soon reached a high and profitable position as a writer of light comedy. He is the most skilful writer of the comedy of manners now working for the English theatre and his plays, *Home and Beauty* (re-named *The Many Husbands in America*) and *The Circle*, put him in direct line of succession to Congreve. J. E. Harold Terry may be said to have been produced by the war. His plays are notable chiefly for their topical quality, but they are well-done and are not without universal appeal. His first play, written in collaboration with Lechmere Worrall, was entitled *The Man Who Stayed At Home*. It was produced at the Royalty theatre Dec. 10 1914, when the condition of theatrical enterprise was still sore from the effects of the war's beginning, and it was an immediate success. Terry wrote a second play with a war motive, entitled *General Post*, produced at the Haymarket theatre March 14 1917. This play, slightly similar in theme to Meredith's *Evan Harrington*, was also a great popular success. In 1921 he produced a play entitled *The Fulfilling of the Law*, in which special appeal was less direct.

The situation at the outbreak of the war, therefore, was one of great hope and of considerable achievement. A finer type of play was being written in every department of the theatre. The influence of Shaw, strong among the intellectuals and distinctly felt among the commercial dramatists, was even discoverable in the work of the melodramatists, whose plays began to show signs of sociological interest. A more enterprising form of management was obtaining a hold on some theatres, and even in minor matters, such as stage décor, a newer and better spirit was informing productions. The vicious principle of subordinating the play to the actor-manager was fading away. Demand was made for a high level of acting throughout the cast, for better team-work, and actors were busy forcing the Actors' Association into a trade union for the purpose of improving their conditions of employment.

**Stage Production.**—Simultaneously with this improvement in the kind of play and of the quality of the acting there was also an improvement in the mechanics of the theatre. The whole business of stage decoration, both from the point of view of scenery and of lighting, was undergoing a profound change, due chiefly to the work of E. Gordon Craig, the son of Ellen Terry. The elaborate "sets" used by Sir Henry Irving and, later, by Sir Herbert Tree involved a serious waste of time in changing scenes, to such an extent that Shakespeare's plays were mercilessly "cut" and even re-shaped to make them fit the requirements of the stage carpenter. The reaction from this sort of thing brought a demand for more manageable scenery. Craig had been experimenting with stage settings for many years and had produced "sets," particularly suited to poetical plays, which were undeniably beautiful. They had the supreme merit of enabling a manager to perform a Shakespearean play as it was written by its author and with no other "cuts" than were made necessary by a different code of manners or by the obscurity caused through the lapse of time. Craig founded a school of decorative artists in Florence and printed his theories in various books of which the principal one is *The Art of the Theatre*. His influence on stage décor has been immense. The famous Moscow Art theatre admittedly derives from him, and it is indisputable that Herr Reinhardt, the great German producer, owes much to him (see *Reinhardt und seine Bühne*, by Ernst Stern and Heinz Herald, Berlin, Eysler & Co.). In England Craig's influence is wide and admitted. Decorative artists, such as Norman Wilkinson, Claude Lovat Fraser, (d. June 18 1921), Hugo Rumbold, Charles Ricketts and Albert Rutherford, derive from him, as do producers such as Granville-Barker, Nigel Playfair, Bernard Fagan and Basil Dean. In America Lee Simonson, Robert Edmond Jones and Rollo Peters acknowledge Craig's authority.

Simplicity was the key-note of Craig's demand. He achieved impressions of height and depth by the use of long curtains and the manipulation of light, and it became plain that in future production would be less a matter of complex machinery and more a matter of manipulated light. Drury Lane, the theatre on the mechanical side, has the appearance of a large engineering works, and its very complicated machinery requires the attention of a large staff of skilled mechanics. There is not likely to be any growth in the extent of engineering-production; although engineering will not entirely disappear from the theatre. We are likely to achieve a revolving stage in every theatre, with deep cellars into which whole "sets" can, if necessary, be dropped. Scenes will often be a matter, not of substantial things, but of actual light. It will then be possible to produce a Shakespeare play in a great variety of scenes, without elaborate "cuts," in a very short time. In America, where electricity is much cheaper than it is in England, experiments with light have been made for many years, with the result that production is in a more advanced state than it is in England. Some of the more modern English producers, such as Basil Dean, had to import electrical apparatus from America.

The movement for greater simplicity in stage décor received some impetus in England from the employment of Craig by Sir Herbert Tree to make the scenery for *Macbeth*. A quarrel, followed by litigation, prevented the experiment from being completely made, but Tree used enough of Craig's designs to show their austere beauty and value. It was not, however, until Granville-Barker began his remarkable season at the Savoy theatre with the production of *The Winter's Tale* in Sept. 1912, followed by *Twelfth Night* in Nov. of that year and *A Midsummer Night's Dream* in 1914, that the new methods of production received extensive consideration. Barker, who had been associated with J. E. Vedrenne at the Court theatre where Shaw's plays first received popular support and Galsworthy became known to the public as a dramatist, and was later associated with Frohman and Dion Boucicault in the Duke of York's season already described, entered into management with Lillah McCarthy, both at the Savoy and at the Kingsway, where he conducted seasons of remarkable value and courage, dramatically and decoratively. A number of plays, old and modern, English and foreign, were produced by him in a highly brilliant and, in several instances, exceedingly beautiful manner. Some of his innovations were not successful in obtaining the degree of beauty at which he aimed—the use of golden-faced fairies in *A Midsummer Night's Dream*, for example, introduced a metallic and heavy element, unattractive in itself, into a world where insubstantiality was the primary requirement, and took, moreover, the English quality out of the play—but it is impossible to deny high tribute to him for the quality of his work and the great distinction he achieved for the theatre. The plays produced at the Savoy, in addition to the three Shakespearean plays already named, were *The Tragedy of* by John Masefield; *The Witch*, translated from the Norwegian of H. Wiers-Jenssen by Masefield; *The Silver Birch* by Galsworthy; *The Wild Duck* by Ibsen; *The Doctor's Dilemma* by Bernard Shaw; a translation of Molière's *Le Mariage Forcé* and Alfred Sutrö's translation of Maeterlinck's *The Death of Tintagiles*. Prior to the season at the Savoy, Barker had conducted a short season at the St. James's where he produced *Androcles and the Lion* by Shaw, followed by a *Harlequinade* composed by Dion Clayton Calthrop and himself. Simultaneously with his season at the Savoy he conducted a season of modern English plays at the Kingsway, producing *The Eldest Son* by Gals-

worthy, followed by revivals of his own play, *The Voyage Inland*, Shaw's very popular piece, *Fanny's First Play*, and Arnold Bennett's *The Great Adventure* in which Henry Ainley and Wish Wynne especially distinguished themselves. Bennett's play was a great popular success, almost as popular as *Milesions* which he wrote in collaboration with Edward Knoblock. Mr. Shaw seemed to be on the crest of a high wave of popularity, for not only had *Fanny's First Play* been performed for more than 600 times, but his five-act comedy *Pygmalion*, with Sir Herbert Tree and Mrs. Patrick Campbell in the principal parts, which was produced at His Majesty's April 11 1914, ran for 118 nights, a long run for any play in so large a theatre. Two plays by Galsworthy, *The Mob* and *The Fugitive*, were not popular successes and went hardly on the general high level of his work. Sir James Barrie's activities during the five years preceding the war, apart from the production of *The Adored One*, were confined to one-act plays, of which *The Twelve-Pound Look* is likely to be a classic example of the short play at its best. Others of these plays, notably *The Will* and *Rosalind* were very near the level of *The Twelve-Pound Look*.

**Effects of the World War.**—The situation, then, at the outbreak of the World War was one of extraordinary interest in the English theatre. The theatrical season 1913-4 had closed with considerable brilliance. Plays of merit had been extensively performed in London and in the provinces, and the repertory theatres were in a fairly healthy condition. A rich level of acting had been discovered. Production was on a genuinely artistic scale. The season of 1914-5 seemed likely to open still more brilliantly than the season just concluded. There was even talk of a national theatre at which the plays of Shakespeare would be permanently performed. On Aug. 4 1914 Great Britain declared war against Germany and immediately the great revival of the English theatre languished and seemed at first in danger of total collapse. Many of the repertory theatres soon ceased to exist. In 1921 the Gaiety theatre, Manchester, passed from the hands of Miss Horniman to a cinema syndicate. A gallant effort to maintain a decent standard of plays was made by some managers: Sir Herbert Tree revived L. N. Parker's poignant piece, *Drake*, and Mr. (now Sir) Frank R. Benson revived *Henry the Fifth* in the laudable desire to satisfy patriotic cravings with something of value. Granville-Barker produced a number of scenes from Thomas Hardy's *The Dynasts* at the Kingsway. But these attempts to keep the theatre on a high level were not successful, and very soon began the process of degeneration which was maintained for the whole period of the war. Some of the managers gave up their efforts to save the tradition they had established: Sir Herbert Tree and Cyril Maude went to America. Others such as Gerald du Maurier remained in London and, with great courage, made a fight for decent drama. Among the plays produced by Gerald du Maurier during the war was a strange piece, very popular, entitled *Dear Brutus* by Sir James Barrie, and a revival of the same author's *A Kiss for Cinderella*. Du Maurier, more than anyone else during the war, kept faith with fine things finely done.

For the first two years of the war, a form of entertainment inaptly described as "revue" was very popular. The chief features of these entertainments were light and colour and jingling music and pretty girls and broadly comic effects. They were a medley of merry-hall and musical comedy and pantomime performances, reduced to a low level. Some of the individual performers in these entertainments, notably Ethel Levey and Violet Loraine, Harry Tate and George Robey, were of indisputable talent, but generally speaking, personalities were submerged in spectacles. Mr. C. B. Cochran, more wise than some of his competitors, exploited personalities in his "revues," which were handsomely and even wittily done, and in Mlle. Delysia and Nelson Keys he discovered two artists of very great merit. Farces of a bold and even indecent character were next to the revues in popular esteem. Oddly enough, certain plays commonly called "highbrow" became popular during the war for reasons which were not concerned with literature. Brieux' banned play, *Les Avariés*, known in England as *Damaged Goods*, was licensed by the censor for public performance on the representations mainly of medical men and sociologists, and it was widely patronized in London and the provinces. The artistic value of *Damaged Goods* is slight, but its sociological value is indisputably great, and it brought a degree of publicity to the discussion of evils which would have been impossible in England prior to 1914. The success of this play led to the public performance of Brieux' play, *The Three Daughters of M. Dupont*, and of Ibsen's  *Ghosts*, from which also the ban was removed by the censor. The latter play, however, is not, like *Damaged Goods*, a propaganda play and it received little support in spite of its being labelled "A Play for Adults only." The rule of the censor was considerably relaxed during the war and his ban was removed from Shaw's one-act play, *The Shewing-up of Blanco Posnet*, but attempts to obtain a licence for *Mrs. Warren's Profession* were unsuccessful. Since the conclusion of the war the censor's rule has been tightened again, but, as a result of the changes made on the recommendations of the Joint Select Committee on Staged Plays (censorship) 1909, the rule bears rather less arbitrarily on meritable work than it formerly did.

The end of the war found the stage in a chaotic condition. The demand for entertainment during the hostilities had been so great

that theatre rents rose rapidly to absurd figures: a common rent at any time between 1915 and 1921 for a theatre in the centre of London was £400 to £500 per week. All other expenses, owing to the high cost of living, increased proportionately, but the price of admission, apart from the entertainment tax imposed during the war (which did not benefit, but rather harmed, the theatre manager) remained at the pre-war figure. Slight increases, after the Armistice, were made in one or two cases, but in 1921 the economic situation in the theatre was that the revenue remained at the pre-war figure while the expenditure was on the post-war scale. Such a situation as that is only endurable when the theatre is filled with an audience, each member of which has paid for his seat. In pre-war times a play could be profitably performed before an audience occupying three-fourths of the seats. A manager could even make ends meet although half his seats were unsold. He could afford to lose money on a production for four or five weeks if he had a reasonable hope that thereafter profitable audiences would assemble for the performances. In 1921 a manager could not hope to make money out of a production unless his theatre was fully occupied at each performance. If a play failed to draw enough people to fill all or nearly all his seats, that play could not be continued in his programme. The financial burden was too heavy to be borne; and for this reason many meritable pieces which might have been "nursed" into popularity were withdrawn almost immediately after production because they had not at once taken hold of popular fancy. The plays which suffer from this economic situation are undoubtedly the better kind of plays. Those which profit from it are the plays without merit other than that of a spectacular character. The best illustration of the effect of this situation on the drama is to be found in the remarkable popularity of *Chu Chin Chow*, an eastern spectacle written by Oscar Asche. This banal piece, a variant of the theme of *Ali Baba and the Forty Thieves*, was produced at His Majesty's theatre—a theatre with an honourable tradition—on Aug. 31 1916. It ran for nearly five years, creating a record of over 2,200 consecutive representations. Every device of colour and light and costume was used in this production. The appeal made was almost exclusively to the eye, very little to the ear and not at all to the mind. *Chu Chin Chow* broke all records for consecutive performances at one theatre and earned large fortunes for those who were concerned in its production.

In spite, however, of the difficult economic situation, of the change in tradition and government of the theatre, there was a remarkable recovery of quality on the English stage after the signing of the Armistice, and plays of quality began to appear, not timidly, but almost arrogantly. A play by Galsworthy, *The Skin Game*, dealing with the conflict between aristocracy and plutocracy (in which both sides are badly besmirched) and susceptible of allegorical application to the war and the treaty of peace, was performed with great success at the St. Martin's and a political comedy, entitled *The Grain of Mustard Seed*, by H. M. Harwood, produced at the Ambassadors' had a singularly successful "run," singular because of the fact that political plays are rarely acceptable to English audiences. Sir James Barrie's *Mary Rose* was performed at the Haymarket with enormous success. In this play he treated the problem of life after death in a fashion which divided playgoers sharply into complete devotees or complete sceptics. *The Skin Game* was successfully produced in America, but *Mary Rose* hardly won the favour in New York that it had won in London. The most interesting post-war success was the popularity with which Gay's *The Beggar's Opera* was revived at the Lyric opera house, Hammer-smith. It was not, however, a success in America. Rostand's *Cyano de Bergerac* was revived with notable success by Robert Loraine, and Bernard Shaw's *Arms and the Man*, also revived by Loraine, had astonishing success with ex-soldiers on account of its anti-romantic treatment of war. Shakespeare's plays are extensively produced. A working-class theatre in the Waterloo Road, London (popularly known as "the Old Vic."), had maintained the standard of good drama throughout the war, and this theatre, handicapped by lack of funds and rather amateurish acting, steadily built up an audience for good plays. After the Armistice its work was amply rewarded. The "Old Vic." became the one theatre in London where playgoers could depend on seeing great drama, and as the quality of the acting was much improved, they could also depend on seeing competent performances. Bernard Fagan in 1920 reconstructed the Court theatre and announced that it would henceforth be a Shakespearean theatre, where four of Shakespeare's plays would be produced annually. But the economic situation made gallant enterprises difficult, and it remains to be seen how far good intentions will survive high prices. The era is one of transition, and the period of transition nearly always causes more pessimism than good hope.

#### UNITED STATES

In America, the theatre, after the end of the war, was in a healthier state than in England. This is more true of New York perhaps, than of the rest of the country. Playgoers in that city seem more willing to patronize good things and to support new enterprises than playgoers anywhere else. A remarkable organization entitled The Theatre Guild of New York has, in three

years, raised itself from an obscure, impoverished and unknown position into that of the only first-class theatrical enterprise in the world which is a great financial success. The Theatre Guild grew out of the activities of a small group of enthusiasts who were known as the Provincetown Players and the Washington Square Players. These players gave performances, usually of one-act plays, in small theatres near Washington Square. They were akin to the movement, very widespread in America, known as the Little Theatre or Community Theatre movement—societies of amateurs producing plays primarily for their own entertainment rather than for profit. The Theatre Guild, when established, secured a long lease on an old theatre, the Garrick, in West 35th St., and began operations with the production of *Bonds of Interest*, translated from the Spanish of Jacinto Benavente. This play (*Los Intereses Creados*) has been done in England both under the American title and under that of *The Bias of the World*. It was not a financial success, and the capital of the Guild, about \$500, was almost exhausted when the directors decided to produce *John Ferguson*, a four-act tragic Irish play by St. John Ervine. This play was not expected to be financially successful, but it falsified anticipation. It was performed in New York for nine months, and enabled the Guild to establish itself more securely. Subsequent productions, including Maselfield's *The Faithful*, were not quite so profitable, but the season ended with greater hope than it had begun. In the following season Tolstoy's *The Power of Darkness*, St. John Ervine's *Jane Clegg*, Strindberg's *The Dance of Death*, and other plays were performed, of which *Jane Clegg*, which ran for six months, was the most financially successful. The third season included the first production in English of Bernard Shaw's *Heartbreak House*, as well as of A. A. Milne's *Mr. Pim Passes By*. Both these plays made much profit for the Guild, the first named running for 150 performances. The success of the Theatre Guild and of *John Ferguson* caused an immediate effect on theatrical entertainments in New York, and one interesting result of it was that a young American dramatist of Irish descent, Eugene O'Neill, was given an opportunity of producing his plays at a first-class theatre. He had already become known as the author of one-act plays when his six-act tragedy, *Beyond the Horizon*, was produced at the Morosco theatre in New York. This play, most skillfully acted, had a great success, and those who are desirous of seeing a fine native drama grow up in America felt encouraged to maintain their hope when they contemplated O'Neill's work. In 1920 he produced a strange play in eight scenes, entitled *The Emperor Jones*, which is what may be called a one-part play, dealing with the journey of a negro into a West Indian forest where he lapses into primal terror. This play was produced by the Provincetown Players and the principal part was acted by a remarkable negro actor, Charles Gilpin. O'Neill is perhaps the most significant figure that the American theatre has produced since the death of William Vaughn Moody, and the quality of his work justifies hopes of raising the standard of American drama to a considerable height.

American dramatists display great technical excellence in their work, together with a tendency towards sentimentalism of a curiously crude character. There is probably more mechanical ability among American dramatists to-day than among any other dramatists in the world, but this ability is seldom related to artistic power and it is frequently used to falsify life. There are signs, however, of discontent with slick sentimentality, and young writers throughout the country are endeavouring to relate technical excellence to plays in which life is truly treated. Dramatic craftsmanship is more closely studied in America than in England, and in many of the colleges and universities students take a course in dramaturgy. The most interesting experiment of this kind is that conducted by Prof. George P. Baker, professor of dramatic literature at Harvard University, who, in what is popularly known as "the 47 workshop," instructs his pupils in the writing and production of plays from the point of view of author, producer, actor and critic. Many of his pupils have written competent one-act plays and several of them have successfully produced more ambitious pieces. One of the ablest of American dramatists and, at the same time, the least prolific, is James Forbes, the author, among other plays, of *The Chorus Lady*, *The Show Shop* and *The Famous Mrs. Fair*. Forbes produces mainly satirical comedies of stage-life, but the last-named piece deals with ordinary life and is a very able bit of work. Other

notable dramatists are Edward Sheldon whose *Romance*, with Doris Keane in the principal part, was extraordinarily successful in England; George Broadhurst—his *Bought and Paid For* was described by Arnold Bennett as one of the best commercial plays he had ever seen; David Belasco; the late Clyde Fitch; Langton Mitchell, the author of a brilliant comedy, *The New York Idea*; Augustus Thomas, whose *The Witching Hour*, *The Harvest Moon*, *As a Man Thinks* and *The Other Girl* are plays of uncommon quality; the late Charles Klein; Eugene Walter, author of two particularly able realistic plays, *Paid in Full* and *The Easiest Way*; Channing Pollock; A. E. Thomas; Booth Tarkington who, more popularly known as a novelist, achieved remarkable success in 1920 with a light comedy called *Clarence*; Zoë Akins; and Susan Glaspell. The condition of the theatre in America at the end of the decade 1910-20 was more hopeful than that in England because of the greater general interest in meritable plays and of the noticeable desire, especially in New York, to support original enterprises.

The standard of acting in America so far as actresses are concerned, is higher than in England, but there is more all-round efficiency among English actors than there is among American actors. The latter excel in character parts, a very admirable instance of this is the case of Frank Bacon in his own play *Lightnin'*—but are less capable in what are known as "straight" parts. With the exception of John Drew there are few American actors who can interpret characters such as were acted by Sir George Alexander. It is very difficult to discover either actors or actresses in America who can speak verse. These flaws in technique are remediable, however, and are slowly being rectified. One result of the war was to cause a distinct decline in the quality of acting among young players in England, and it is probably true to say that there was less acting ability among the younger members of the English theatrical profession at the end of 1920 than at any other period in the history of the English theatre. In America, on the contrary, there was a marked growth in technical skill among young actors and actresses.

GERMANY

In 1910, the condition of the drama in Germany was very curious—declining in Berlin, but flourishing in the provinces. Metropolitan taste was fickle and vulgar; provincial taste was steadfast and of high quality. The result of this odd reversal of customary positions was that the German provinces absorbed almost the whole of the interest of dramatic students. More experiments were made outside Berlin than were made inside it, not only in the quality of the plays performed, but also in the methods of production and in the interior economy of the theatre. Volkstheater (people's theatres) were organized in many places, at which performances of classical and modern pieces were given moderate prices. The two Freien Volkstheatern of Berlin, which were typical in most respects of all the other people's theatres, had between them a membership of 60,000 persons, of whom a considerable number were workmen. These Freien Volkstheatern contracted with various theatre-managers for the performance of specified plays for their members, and the larger of the two, Die Neue Freie Volkstheater, was spending £25,000 per annum in 1910 on plays produced at 11 different theatres. This society even started a building fund, which in that year had reached £5,000, for the purpose of establishing a theatre of its own, to hold 2,000 persons. The members of this society paid one shilling for each performance witnessed, and seats were allotted by ballot. A similar society, with a membership of 9,000 persons, existed in Vienna, under the direction of Stefan Grossmann, a dramatist. The Cologne Stadt-theater organized performances on lines similar to those of the Volkstheatern, on Sunday afternoons before audiences drawn from workmen's societies which were allowed to nominate the play to be produced. In 1909, the trade unions of Cologne chose Galsworthy's *Sirife* for performance, and this play was received with enormous enthusiasm. The same was the case with the provincial section in 1909. Each subscriber to this society was to be admitted to one performance per week in a season of 40 weeks and to receive a theatrical paper, delivered free of charge, together with free admission to a number of lectures, for an annual subscription of 20 shillings! The number of Stadtbund theatres was increasing remarkably, and certain towns either subsidized or completely owned the local theatre. The following is a record of sums paid by German cities and towns for their own theatres:—Cologne, £25,000; Frankfurt, £13,000; Barmen, £6,000; Dortmund, £6,000; Essen, £4,000; Elberfeld, £4,000; Aachen, £3,500; Breslau, £3,000; Düsseldorf, £2,500; Magdeburg, £2,500; Kattowitz, £1,000; Thorn, £1,000.

The two great German dramatists, Gerhart Hauptmann and Hermann Sudermann, had reached the apex of their powers in 1910 and were beginning to yield place to new men, of whom the chief were Frank Wedekind, Arthur Schnitzler (an Austrian and, like Somerset Maugham and H. M. Harwood in England, a doctor of medicine) and Hermann Bahr. Problem and "tendency" plays were prolifically produced, and the drama of intellectual concepts rather than the drama of human emotions seemed to predominate. Just before the outbreak of the war a number of excellent general plays were being performed, such as *Haus am Meer* by Stefan Zweig and *Mutter und Geliebter* by W. von Molo. But, apart from the extraordinarily experimental character of much of German drama

and stage production during this time, the general range of theatrical entertainments was very catholic, extending from harshly realistic plays of the soil, such as Sudermann's *Strandkinder*, to purely poetic plays, such as *Medusa*, by a young dramatist of promise, Hans Kyser. In addition to the very diverse quality of native drama, the German theatre produced many foreign plays, equally diverse in character, ranging from Shaw's plays to plays by Jerome K. Jerome, Ibsen, Björnson and Strindberg (who died in 1912) had much popularity in Germany, and so had many French dramatists, but none of them had greater popularity than Shaw, Oscar Wilde and Galsworthy. Other English writers, Maugham, Sir James Barrie, Sutro, Arnold Bennett and Edward Knoblock, Monckton Hoffe, H. H. Davies, Sir Arthur Pinero, W. J. Locke and L. N. Parker, were freely and extensively admitted to the German theatre. Shakespeare, of course, had long been a popular author in Germany and this popularity did not decline during the war.

Hauptmann, who received the Nobel prize on his fiftieth birthday in 1912, was fairly prolific during the five years preceding the war. *Giselda*, founded on Boccaccio's legend, was produced in 1909, and was followed in 1911 by *Die Ratten* (*The Rats*). *Gabriel Schilling's Flucht* (*The Escape of Gabriel Schilling*) was produced in 1912, and in 1913 came the famous Festival Play commissioned by the city of Breslau to celebrate the war against Napoleon for freedom. This play was produced by Reinholdt in the new rotunda of the Breslau Exhibition, and its democratic sentiments were so displeasing to the Junkers that it provoked a great uproar. The then Crown Prince threatened to cancel his patronage of the exhibition unless the play were withdrawn—which was done. Another play, entitled *Der Bogenspanner Odysseus* (*Odysseus the Archer*), was written in 1913. Hermann Sudermann was less prolific than Hauptmann. His *Strandkinder*, a play about people living on the shores of the Baltic Sea, was produced in 1909. This play had considerable affinity with the work of a dramatist who died in 1909, Ernst von Wildenbruch, two of whose plays, *Lieder des Euripides* and *Der Deutsche König*, were performed, after his death, in that year. *Strandkinder* was followed by an historical piece, entitled *Der Blinde von Syracus* in 1911 and *Der Gute Ruf* in 1913.

The ascending dramatists, Bahr, Wedekind and Schnitzler, produced many plays in the first half of the decade, as did another well-known, but peculiar and unsuccessful dramatist, Herbert Eulenberg. Bahr, whose gift is for human comedy, is known abroad by *Das Konzert* (*The Concert*) which was not notably successful in London, but was very popular in America as well as in Germany. Another play, *Kinder*, was produced simultaneously in 20 different German theatres in 1910. This was followed by *Das Dreifuss* and *Das Tauschen* in 1912 and by *Phantom* in 1913. Frank Wedekind, a dramatist of queer, undisciplined genius, was by far the most prolific of all the dramatists in Germany during the period under review and probably of all the dramatists in Europe. He produced nine plays in five years, four of which, indeed, were in one act. The plays were *Die Junghe Wahn*, *Die Zensur* (one act), *Der Liebeswahn*, *Die Büchse der Pandora*, and three one-act plays, *In Allen Saiten Gereicht*, *Mit Allen Hundem Gehetzt* and *In Allen Wassern Gewaschen*, which were combined in 1911 under the general title of *Schlöss Wetterstein* and issued with the statement that they contained his views "on the inner necessity on which Marriage and the Family rest." These plays were followed by *Der Stein der Weisen* and *Fransiska*, the latter, prohibited by the censor in Vienna, being produced in Munich. Arthur Schnitzler, a Viennese, known in England through the *Anatol* plays, translated by Granville Barker, and *Der grüne Kakadu* (*The Green Cockatoo*); had four plays performed in the first five years of the decade, *Komische Misset*, *Der junge Medardus* (which took five hours to perform), *Das Weisse Land* and *Professor Bernhardt*, the latter of which was forbidden in Vienna. Herbert Eulenberg was responsible for two plays, *Die wärrliche Vater*, *Anna Wolenski*, *Samsen* (his most popular piece); *Alles um Geld*, *Alles um Liebe*, *Belinda* (which won the Volkskammer prize), *Zeichnung* and a one-act play, *Paul und Paula*. Hans Kyser, in addition to the play already named, produced *Titus und die Jüdin* and *Ersiehung zur Liebe*.

The list of meritable German dramatists is a very long one. It includes men such as Paul Ernst, Hans Franck, Otto Harnack, Carl Schönherr, whose Volkstück ("people's play") *Glaube und Heimath* was performed in more than a thousand theatres in six months; Edward Stucken, Max Halbe, Ludwig Fulda, Ludwig Thoma, Franz Dulberg, Leo Birinski, Reinhard Sorge and Arno Holz. The records of the German theatre during the war indicate that a better standard of play was maintained there than elsewhere. Since the signing of the Armistice a new group of dramatists has arisen, of whom Georg Kaiser is known in England, because of the performance of his play *Von Morgens bis Mitternacht* (*From Morn to Midnight*) before the Stage Society in 1919. He experiments with new dramatic forms, but his work hardly merits the extravagant claims made for it. In addition to the play named, he has written others, of which the most meritable are *Die Bürger von Calais* (*Burgers of Calais*) and *Die Koralle* (*The Coral*). A violence of sentiment has been manifested in much of the post-war German drama, and this was most plainly to be detected in Schnitzler's *Reigen* (*The Chain*).

Perhaps the most interesting figure in the German theatre since the signing of the Armistice has been Max Reinhardt, who derived

with more practicability; from Gordon Craig. Prior to the war he was known in England as the producer of *The Miracle*, *Oedipus Rex* (with Sir John Martin Harvey and Lillah McCarthy in the principal parts) and *Susanna*. His taste is for spectacular pieces of an ambitious nature. He was in 1901 in charge of Das Grosse Schauspielhaus (the Great Arena theatre), which was opened in 1899 and has seating capacity for 3,000 persons.

## FRANCE

In 1910, the theatre in France gave less occasion for satisfaction than the theatre either in England or in Germany. The traditions of decent drama were, of course, maintained at the Comédie Française, the Antoine and the Odéon, but, broadly speaking, plays of quality were few in number and "revues" of a very vulgar character were growing in popularity. That bad state of affairs could not last, and after 1910 until the outbreak of the World War, when the French theatre for obvious reasons completely collapsed, there was a revival of quality in French drama. The French theatre, too, which had not previously offered much hospitality to foreign plays, began to open its doors, not widely, indeed, but slightly to plays written by foreigners. Shakespeare suddenly came into fashion. *Hamlet* was produced at the Comédie Française, *King Lear* at the Antoine, *Julius Caesar* at the Orange Fêtes, and *Romeo and Juliet* at the Odéon. Camille de Saint-Croix organized single performances of many Shakespearean plays which were highly praised. One of Shaw's plays was performed in Paris, but without much favour. English musical comedy, produced on a more extravagant scale than is customary in France, became popular, and George Grossmith set the Parisians to singing "I-pi-addy-ay-y-ay."

The most interesting play produced in Paris during the first five years of the decade was undoubtedly Edmond Rostand's *Chanteclair*, which had been anticipated for seven years before it was performed for the first time at the Porte-Saint-Martin in 1910. It had not the great success of *Cyrano de Bergerac*, but it caused much discussion. Lucien Guitry played the part originally intended for the late Constant Coquelin, which part was played in New York by Maude Adams. Rostand, who was born in 1868, died in 1918. Another death of great importance to the French theatre was that of Jules Claretie, who, after controlling the Comédie Française for 28 years, died in 1913. Claretie conducted the difficult affairs of the national theatre with very great skill and diplomacy, and showed clearly that while a national theatre is not a forcing-house for genius, it is certainly a place in which the level of honourable drama is highly maintained. He was succeeded by Albert Carré, who remained in charge of the theatre until he was called up for military service during the war, when he was succeeded by Emile Fabre, a dramatist. Paul Hervieu, the dramatist, died Oct. 25 1915, and Mme. Réjane, the famous actress, June 14 1920.

Much useful, if not particularly significant, work was done by French dramatists from 1910 to 1915, but none of the disintegrating and insurgent influences detectable both in the English and the German theatres appeared to affect the French theatre. Stage décor, for example, is singularly poor in France, where, on the other hand, the standard of acting is very high. In addition to Rostand's plays, notable pieces were produced by Henry Bataille (*Le Songe d'un Soir d'Amour* and *La Vierge Folle*—the first of which, done at the Comédie Française, was hardly so successful as the second, done at the Gymnase), by Pierre Wolff (*Ruisseau* and *Marionettes*), Henri Bernstein (*L'Assaut* and *Le Secret*), George Duhamel (*Les Lumères*), Brieux (*La Femme Seule*, done in England under the title of *Women on Her Own*), Maurice Donnay (*Les Ecoleuses*), Sacha Guitry (*Le Beau Mariage* and *La Prise de Berg-op-Zoom*), De Flers and de Caillavet (*Habit Vert*) and Tristan Bernard (*Jeanne Dore*—with Sarah Bernhard in the cast).

After the outbreak of war, the French theatre for a considerable period practically ceased to exist. Conscription and war regulations, together with enemy air-raids and proximity to the front, made theatrical enterprise in Paris either impossible or exceedingly difficult. Some companies of French players came to London. There were only two new plays produced in Paris in 1915—*Les Deux Vestales*, a farce of an old-fashioned broad character, done at the Gymnase, and a translation, made by W. B. Perier, of the English play, *The Man Who Stayed at Home* by J. E. Harold Terry and Lechmere Worrall, which was done at the Théâtre des Bouffes Parisiens under the title of *Kit*, with Max Dearly in the cast. Several war plays, not particularly meritable, were done in Paris towards the end of the war or immediately after the signing of the Armistice, and Sacha Guitry's play *Deburau* was also produced. A translation of this play, done into rhymed couplets, has been made by H. Granville-Barker and was produced in New York in 1921 with great success. Edmond See's *Saison d'Amour* was produced in 1919, and Sacha Guitry, rapidly acquiring a high place in France as a dramatist and an actor, was responsible for *Pasteur*, a farce entitled *La Mari, La Femme et L'Amant* (a title which sufficiently indicates the character of the piece), and a comedy called *Mon Père avait Raison*. The Guitrys, father, son and daughter-in-law, gave a season of their plays in London in 1920 which was exceedingly successful. (St. J. E.)

**DRESDEN, Saxony** (see 8.574).—The pop. of Dresden, according to the census of 1910, was 529,326; in 1910, without some suburbs

since incorporated, it was 548,308. Dresden was perhaps harder hit by the World War than most other towns in Germany. The whole structure of its economic life had been dependent upon visitors, especially foreigners, and the outbreak of the war brought this to a sudden stop. In addition, the shortage of food, serious everywhere, was more especially felt in Saxony and her capital, which were dependent mainly upon industry. Lastly, the revolution swept away the life of the Court, which meant a great deal for Dresden. With the revolution came the development of extreme political tendencies among the working classes of Dresden, which led to constant disturbances, strikes, etc., although the violent and sanguinary encounters associated with the insurrectionary movement in western Saxony, were less widespread in Dresden. But the assassination of Neuzing, the majority Socialist Minister of War, on April 12 1919, and the sanguinary street fighting of Jan. 9 and 10 of the same year, are sufficient proof that the capital of Saxony was not immune from scenes of violence. After 1914 the expansion of the city came to a complete standstill, and in 1921 Dresden, like other towns, was suffering severely from lack of housing accommodation. After the revolution there was a majority of extremists in the Municipal Council, and the financial position of the city had become very precarious.

The collections and museums will doubtless maintain the reputation of Dresden as a centre of art. The Royal Opera, which enjoyed a world-wide reputation before the World War, has not been able as a State Opera to maintain its high artistic level. Industry came to a complete standstill during the war—the manufacture of cigarettes, for instance, which was very flourishing, had to be cut down owing to lack of raw material—but by 1921, some recovery had taken place and Dresden showed signs of returning prosperity as a resort for visitors. (C. K.)

**DRINKWATER, JOHN** (1852— ), English poet, playwright and critic, was born at Leytonstone, Essex, June 1 1852 and educated at the Oxford high school. After twelve years' work as an insurance clerk he began to devote himself to theatrical enterprise, and became manager and producer to the Pilgrim Players, who developed into the Birmingham Repertory Theatre Company. His first volume of poems appeared in 1908 and his first play *Cophetua* (in verse) in 1911. He subsequently published several volumes of verse, critical studies on *William Morris* (1912), *Swinburne* (1913) and others, and several plays, of which *Abraham Lincoln* (1918) was produced with great success both in London and in America.

**DRIVER, SAMUEL ROLLES** (1846–1914), English divine and Hebrew scholar (see 8.585), died at Oxford Feb. 26 1914. His later works include *Four Papers on the Higher Criticism* (with F. Kirkpatrick, 1912).

**DROYSSEN, GUSTAV** (1838–1908), German historian (see 8.596), died at Halle in 1908.

**DUBAIL, AUGUSTIN YVON EDMOND** (1851— ), French general, was born at Belfort April 1851. At the age of 17 he entered the military academy at St. Cyr, and on July 15 1870 was appointed a sub-lieutenant of infantry, having passed seventh out of 310 candidates. He took part in the Franco-German War and was captured at Metz in Oct. 1870. Released in April 1871 he rejoined his regiment, and served with the army of Versailles in the operations against the Commune. He was appointed captain and transferred to the 81st Inf. Regt. in Nov. 1878. From Oct. 1880 to Feb. 1883, and again from Nov. 1883 to Jan. 1886, he had an appointment as professor at the École Spéciale Militaire St. Cyr. In June 1886 he was made a chevalier of the Legion of Honour. In Nov., while serving in Algeria, he was promoted lieutenant-colonel; and in Oct. 1901, while still in Algeria, was made a colonel and given command of the 1st Regt. of Zouaves. On returning to France he took over the Alpine Brigade at Grenoble. In 1906 he became commandant of St. Cyr—an appointment which he held for three years. He was made a divisional commander on Dec. 25 1908, being appointed to the 14th Div. at Belfort. He later commanded the IX. Army Corps. In 1911 he was made chief of the general staff and a member of the Superior War Council. On the



outbreak of the World War Gen. Dubail took over the I. Army, which (with the II. Army under Gen. de Castelnau on the left) was responsible for the offensive into Lorraine, and later for the defence of the eastern fortress line against the armies of Prince Rupprecht of Bavaria. The stubborn resistance of Dubail and Castelnau not only nullified the threat of invasion but insured a pivot for future French manoeuvres; it prepared the way indeed for the Marne victory. Gen. Dubail was given the Grand Cross of the Legion of Honour (Sept. 18 1914). On the withdrawal of the II. Army to the Somme, Dubail took charge of the whole line between Verdun and the Vosges, and when in Jan. 1915 the armies along the front were grouped under three headquarters of groups of armies, Dubail was placed in charge of that of the east, comprising the III. of Verdun, his old I., and the Vosges force. In Oct. of the same year he was awarded the médaille militaire. On April 6 1916 he was made military governor of Paris. He was placed in the "Second Section"—on reaching the age limit—in April 1916, but retained his appointment as military governor of Paris. After his final retirement he was appointed Grand Chancellor of the Legion of Honour.

**DUCLAUX, AGNES MARY F.** (1856—), Anglo-French poet and critic (see 8.632), published after 1910 a volume of essays, *The French Ideal* (1911); a study of *Madame de Sévigné* (1914); *A Short History of France* (1918); *Twentieth Century French Writers* (1920) and a life of *Victor Hugo* (1921).

**DU CROS, WILLIAM HARVEY** (1846—1918), British manufacturer, of Huguenot descent, was born in co. Kildare, Ireland, June 19 1846. He was educated at the King's hospital, Dublin, and became founder of the pneumatic tire industry and a pioneer in automobile construction. From 1906-8 he represented Hastings in the House of Commons. He died at Dalkey, co. Dublin, Dec. 21 1918.

**DUCTLESS GLANDS** (see 8.633).—Much new work on the physiology, pathology and medicine of the ductless glands has been done since 1914.

There are two ways in which the *consensus partium* in the animal economy is brought about. The best known of these is that which occurs through the nervous system. But it has been recognized during recent years that other agents take part in this process of coordination. These are called the *ductless glands* through their products the *internal secretions*, which have also been called *hormones*. The latter have, however, been renamed *autocoid* substances by Schäfer, and these again divided into two groups: those which excite metabolic processes and those which depress them. The former autocoids are called by him *hormones*; the latter *chalones*.

In the glands of internal secretion, or as they are sometimes called the *endocrine* organs, the material secreted is passed away not through a duct but by means of the veins leaving the organ. This material when it reaches the general blood stream acts in the manner of a chemical messenger, or of a drug, producing effects upon various organs and tissues of the body. The ductless glands which we shall have to consider are (1) the *adrenal gland*; (2) the *thyroid gland*; (3) the *parathyroid glandules*; (4) the *pituitary body*; (5) the *pineal gland*. It is probable that the thymus is not an organ of internal secretion. In addition to these certain other glands furnished with a duct and providing an ordinary or external secretion are supposed to supply the body with internal secretions also. This applies to the pancreas. Further, the *gonads* (reproductive organs) have an endocrine function.

**The Adrenal Gland.**—For many years it has been customary to refer to the *cortex* and the *medulla* of the adrenal body as the suprarenal capsule. But comparative anatomical studies have shown us that this is an inaccurate view of the problem. It is only in mammals that the terms *cortex* and *medulla* as applied to the two parts of the organ are strictly appropriate. In elasmobranch fishes we have to deal with a series of paired *chromaffin* bodies in connexion with the sympathetic ganglia, and with an interrenal body placed in the middle line between the two halves of the kidney. The first of these is the *homologous* of the mammalian medulla while the interrenal body corresponds to the

mammalian cortex. Even in mammals a trace of the original arrangement still persists, e.g. the sympathetic ganglia contain groups of chromaffin cells and there are other outlying masses of chromaffin tissue. The cortex also is not the sole representative in mammals of the original interrenal body. So that the problem before us is by no means to discover the function of a single organ but to ascertain the significance of the chromaffin tissues (of which the adrenal medulla is only a part) and of the cortical tissues (of which the adrenal cortex is only a part, albeit the principal one).

The chromaffin tissues everywhere contain adrenin, the formula for which is:

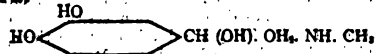

This substance is generally supposed to constitute the internal secretion of these tissues. When injected into the circulation of a living animal it produces effects similar to those brought about by stimulation of the sympathetic nervous system. That is to say, its action is sympathomimetic. Other substances having a similar chemical constitution will produce similar physiological effects. The most striking of such effects are constriction of arterioles and an enormous rise of blood pressure, dilatation of the pupils and inhibition of the muscular coats of the alimentary canal. Small doses often produce results qualitatively different from medium or large doses.

The secretion of the chromaffin tissues does not appear to be essential to life. It is tolerably certain that it does not help to maintain the normal blood pressure. It is possible that it is important for the activity of muscular structures under circumstances of physiological and especially of emotional emergency.

Of the functions of the cortex we know practically nothing, and yet we are justified in regarding this portion as the adrenal body in the true sense of the word. Experimental and clinical evidence has taught us that it is the part which is essential to life. It seems probable that it has to do with the development of the organs of reproduction. Tumors of the adrenal cortex are frequently associated with sexual precocity in young children.

The only disease definitely traceable to a lesion of the adrenal body is that known since 1855 as Addison's disease. The most striking symptoms are a peculiar bronzing of the skin, extreme muscular weakness, low blood pressure, vomiting and other symptoms probably referable to the sympathetic nervous system. The pathogenesis of the skin pigmentation cannot be correlated with anything we know of the physiology of the gland. The muscular weakness is supposed to be pathognomic and attributable to the absence of circulating adrenin. The cases are always fatal, and treatment with adrenal substance seems to be of no use.

**The Thyroid Gland.**—The thyroid is developed as an outgrowth of the embryonic pharynx between the first and second branchial clefts. It is at first single and solid, but later becomes bilateral and divided up into closed vesicles. It is doubtful how far the lateral rudiments or post-branchial bodies take part in the formation of the mature thyroid in mammals. The vesicles hold a peculiar "colloid" material which contains iodine. The blood supply is very rich and nerves are provided from both vagus and the sympathetic.

Extirpation of the thyroid produces varying results according to the kind of animal employed and according to its age. The symptoms are not always very clearly defined, but they consist in general terms of the manifestations of sluggish metabolism. In young animals there may be almost complete cessation of growth though there is a tendency to adiposity. The symptoms differ from those of myxoedema in the human subject.

**DISEASES OF THE THYROID.**—**Myxoedema.**—This condition is found in middle-aged or elderly subjects, usually women. The skin becomes altered, hands and feet swollen, lips and tongue enlarged. The oedema does not put on pressure, and there is mental dullness. The symptoms are in fact those of pronouncedly slowed metabolism. The disease is clearly due to deficient thyroid secretion, and may be kept in abeyance or permanently cured by treatment with thyroid substance.

**Cretinism.**—This is usually due to atrophy of the gland at the time of birth. The growth of the skeleton is arrested and the nutrition of the muscles and skin is seriously affected, so that the children are deformed, and, as a result of lack of mental development, idiotic. Treatment with thyroid substance is often beneficial.

**Simple Goitre.**—The precise pathological condition varies in different cases. The commonest form is now very generally considered to be due to an infection from drinking-water. Many cases can be cured by treatment with intestinal antiseptics and sterilization of the water. Small doses of iodides have been found useful as a prophylactic when administered to children in goitrous districts.



**Exophthalmic Goitre.**—This disease is characterized by the three cardinal symptoms, enlargement of the thyroid, protrusion of the eye-balls and a rapid heart beat. It is usually ascribed to an over-secretion of the thyroid gland, though many authors prefer to attribute it to a disturbed function of the organ. Complete rest often suffices to cure the condition, though many surgeons recommend removal of a large part of the gland.

Kendall believes that he has isolated the active principle of the thyroid gland, and to this he gives the name of *thyroxin*. It is alleged that this substance may be used instead of thyroid substance in cases of thyroid insufficiency and that the results are as satisfactory as when the gland substance is employed.

**The Parathyroids.**—In the great majority of mammals there are four parathyroids, two in relation with each lobe of the thyroid. The glands do not contain vesicles but consist of solid masses of cells. They are developed from the epithelium of the third and fourth branchial clefts. Most observers do not believe that they are functionally related to the thyroid.

Extirpation of all four parathyroids is rapidly fatal in the case of many animals. Where death does not occur it is usually assumed that accessory parathyroids are present. It is certainly true that in many of the herbivora such accessory glands are frequently present. The symptoms which occur after extirpation are those of *tetany*—muscular spasms, rapid respiration, salivation, etc. The condition is now usually called *tetania parathyreopriva*, and Koch and Noël Paton ascribe it to intoxication by guanidin. They believe that the parathyroids control the metabolism of guanidin and in this way exercise a regulative action upon the tone of the skeletal muscles.

**Idiopathic Tetany.**—Since the symptoms of this disease strikingly resemble those of tetania parathyreopriva, it is now very generally believed that they are due to disease of the parathyroid. It is sometimes alleged also that paralysis agitans, chorea, epilepsy, and eclampsia are due to disturbance of the functions of these bodies.

**The Pituitary Body.**—The pituitary body consists of two principal portions, the *anterior or glandular*, and the *posterior or nervous*. The former is developed as an evagination from the ectoderm in the buccal region. The posterior portion is an outgrowth from the base of the brain. Covering the latter is a second glandular portion called the *pars intermedia*.

The glandular portion seems to give rise to substances which are essential for the proper development of the skeleton and other tissues of the growing animal, and Robertson states that he has succeeded in isolating from this lobe a substance called *sethin*, which hastens growth in young animals. Pituitary feeding is stated to increase the output of eggs in laying hens.

Extirpation experiments seem to point to the anterior lobe as the part which is essential to life. But from the posterior lobe certain active extracts can be obtained. These extracts when injected into the circulation of a living animal produce a rise of blood pressure which is more prolonged than that produced by adrenin, but a second injection may produce a fall. The extract produces a sphenic effect upon uterine contractions and upon those of the intestine and bladder. It also causes dilatation of the pupil and constriction of the bronchioles. Pituitrin also causes a marked increase in the flow from the kidney and the mammary gland. A striking effect on metabolism produced by the administration of pituitary substance is a lowering in the tolerance for sugar.

**DISEASES OF THE PITUITARY.**—**Hyperpituitarism.**—Overgrowth of the anterior lobe usually of an adenomatous nature gives rise to increased growth of the bones of the extremities and of the face, and, if it occurs in young subjects, to gigantism, when, as in older subjects, it chiefly affects the face and the ends of the long bones, the condition is called *acromegaly*. Diminished sugar tolerance usually supervenes as the other parts of the organ become affected. There may be actual glycosuria and frequently polyuria.

**Hypopituitarism.**—In this condition the body does not grow, although there may be an extensive deposition of fat. There is marked failure in sexual development. Sugar tolerance is very pronounced and there is arrested mental development. In cases which do not arise until adult age has been reached obesity and increased sugar tolerance are the most striking symptoms.

A functional relationship between the pituitary and the other ductless glands (especially the thyroid) is more than probable.

**The Pineal Gland.**—This tiny structure has usually been considered as belonging to the group of "vestigial remains,"

and its chief interest to morphologists centres round its homology with the median eye of reptiles. It is developed as an outgrowth from the third ventricle of the brain. But even in lower vertebrates there is some evidence that a glandular constituent has to be reckoned with. Within the last few years numerous writers have urged that in mammals, including man, the organ is of considerable importance, and that it belongs to the group of glands furnishing an internal secretion.

Extirpation experiments have been carried out in some animals, and it is stated that removal of the organ accelerates growth of the body and especially of the reproductive apparatus, or at any rate a hastening of the development of the reproductive functions.

Tumors of the pineal gland are associated with abnormal growth of the skeleton in children, and with early and precocious development of the secondary sexual characters. In order to correlate these findings with the results of extirpation experiments it is assumed that the tumour gives rise to a condition of hypopituitarism. It will be remembered that the common tumours of the pituitary body are considered to be adenomata and to give rise to a hypersecretion.

Injection of extracts made from the pineal gland give rise to special effects upon the blood pressure, respiration, secretion of glands, or other functions which can be investigated by ordinary kymographic methods. But it is alleged that administration of extracts over a long period to growing animals hastens the growth and development of the reproductive organs. If these statements are correct they only tend in the present stage to complicate the problem, for it is certainly contrary to expectation to learn that removal of an organ from an animal and its administration to the animal as food or drug will produce similar results. The whole subject is obscure, and here, as in the case of some other of the ductless glands, it is probable that our experimental technique is too faulty or too limited to enable us yet to draw any just conclusions.

**The Testes.**—The effects of castration in man have been known for a very long time. The absence of hair from the face, the undeveloped larynx and the persistent soprano voice resulting, and the tendency to gigantism and obesity are among the more striking of the characters of an eunuch. In male stags the antlers do not grow, and in the cock the comb fails to develop. These results do not occur when the vas is tied. In some animals and under favourable conditions these secondary sexual characters may be induced if a testis is transplanted from another animal. So that they must be attributed to an absence of a specific internal secretion.

The elements of the testis which are usually supposed to furnish the internal secretion are the *interstitial cells* of Leydig. These are of an epithelioid character and contain lipid granules. These structures are not always very striking in sections through the testis, but they are more marked in some animals than in others.

Injection of extracts of the testis was observed many years ago by Brown-Séquard to have a rejuvenating or stimulating effect upon the subject so treated, but it is doubtful whether the effect is specific or more marked than with other extracts.

**The Ovaries.**—It is well known that if both ovaries are removed from a young animal the uterus does not develop, menstruation does not occur, and the mammary glands fail to grow.

Extracts made from the ovary produce certain effects upon smooth muscle, but it is not certain that these effects are specific.

The *corpus luteum* appears to be concerned with the fixation of the embryo in utero and also with the growth of the mammary gland and the secretion of milk. As in the case of the testis there is a tendency to attribute the internal secretions of the ovary to certain *interstitial cells*. These, however, are not present in all animals or at any rate are not present during all periods of the sexual cycle. Extracts of ovary have been employed in the same manner as those of testis, and the same criticism applies.

**The Carotid Body.**—Situated at the bifurcation of the carotid artery and consisting, in many animals, of only a few cells, it is not known that the carotid body, or carotid gland, carries out any important functions. Among the constituent cells are a few of the chromophil variety, and these are capable, presumably, of furnishing a small amount of adrenin to the general circulation.

**The Cerebral Body.**—This structure is included in our list because it has been alleged that it contains chromophil cells. This, however, does not appear to be the case. The body is apparently an arterio-venous anastomosis. (S. V.)

DU MAURIER, GERALD (1873— ), English actor, was born at Hampstead March 26 1873, the son of George Du Mau-

rier (see 8.658). He was educated at Harrow and first appeared on the stage at the age of twenty at the Garrick theatre, London, then under the management of John Hare. Two years later he joined Herbert Tree at the Haymarket and played with him in Shakespearean plays and his father's play of *Trippy*, as well as in various melodramas. Amongst many later successes may be mentioned his acting in Barrie's *Peter Pan*, *The Admirable Crichton*, *Little Mary*, *What Every Woman Knows* and *Dear Brutus*, and his performances as the hero of Conan Doyle's *Raffles* and McCutcheon's *Brewster's Millions*. He wrote the play *A Royal Rival*, produced by Lewis Waller, and with his brother, Guy Louis Busson Du Maurier (1863-1915), author of *An Englishman's Home* (1909), wrote *Charles I. and II.*

**DUNAJEC-SAN, BATTLES OF THE.**—The line of the river Dunajec and that of the San, both in West Galicia, marked the two successive stages in the break-through battle which initiated the Austro-German offensive of 1915 on the eastern front.

After the severe fighting on the Carpathian front (see CARPATHIANS, BATTLES OF THE) there ensued a pause in the second half of April 1915, both on the side of the Central Powers and on that of the Russians, whose attempts at a break-through had failed. Fighting continued only in the sector of the German Southern Army up to the end of the month, the crowning day being April 24, when Hofmann's Austro-Hungarian corps stormed the Ostry heights.

The general situation on the eastern front was at this time somewhat unsatisfactory. The Austro-Hungarian armies in the Carpathians were exhausted; the IV. and I. Armies, Weyrsch's Army, and the German forces on the eastern front were certainly holding their ground, but were continually being weakened by having to detach troops to the Carpathian front. The Russians were in similar case; the combats in the mountains had absorbed not only great masses of men but also quantities of material, which could not so readily be replaced. Thus, although the danger in the Carpathians was not yet over, Russian offensive movements on a large scale were hardly to be expected.

The position was far more favourable on the German western front, where the Germans awaited the French attacks with calm confidence, while behind the lines the organization of 14 new divisions was nearing completion. The opportunity for improving the situation in the E. appeared, therefore, to have arrived. The desirability of relieving the pressure on the Carpathian front seemed self-evident, and the only question was as to the direction and method of execution of the offensive. The choice appeared to lie between an offensive on a large scale against the whole Russian front, combined with enveloping movements against its northern and southern flanks, and a direct break-through at some part of the line. For the latter operation the area Gorlice-Tarnów appeared to offer advantages; it had been largely denuded of troops by the Russians during the course of their Carpathian offensive, and a drive on Sanok, via the Jaszlo and Krosno basins, would get into the rear of the Russian forces in the Carpathians and roll them up. The length of time that would be necessary for the preparation of an attacking group in the Carpathians, where the railway communications were very bad, would be bound to militate against the success of the first plan, while an enveloping movement in the N. would be too far distant to have any lasting influence in improving the situation in the Carpathians. West Galicia, on the other hand, was well suited as an area of assembly for an offensive group, and the possibilities of success were highly promising.

The High Commands of both the Central Powers had early in April decided, independently of each other, for the second solution of the problem; indeed, the Austrians had, in the middle of March, undertaken an offensive towards Gorlice with weak forces, which resulted only in a tactical success. When the Austrians early in April renewed their request for German divisions to be dispatched to the Carpathians the whole matter came up for discussion; the preliminary conditions for the offensive were arranged by telegraph, and the final decision was arrived at on April 14, at a conference between the two chiefs of the general staffs in Berlin.

The XI. Army, under Gen. von Mackensen, was organized as a shock group, consisting of eight German divisions from the western front, the two divisions of the Austrian VI. Corps, and the 11th Honved Cav. Div.; and it assembled behind the right wing of the Austrian IV. Army. This latter was also placed under Mackensen, who was himself subordinated to the Austrian High Command. These two armies were to carry out the main attack in West Galicia, while the armies of Dankl N. of the Vistula and those of Boroewicz, Böhm, Linsingen and Pflanzer were to display all possible activity and engage the enemy in their front so as to prevent him from detaching troops to the main attack. Simultaneously two demonstrations in the Praszysz and Novgorod areas, and a raid on Memel, were planned.

After the completion of the assembly of the XI. Army, the distribution of the Austro-German forces in West Galicia and the Carpathians was as follows: In West Galicia, on the Lower Dunajec, the heights of Wal, and the Biala as far as Cieżkowo, was the Austrian IV. Army under Archduke Joseph Ferdinand (7 inf. divs.). To the right of this, the XI. German Army, under Gen. von Mackensen (10 inf. and 1 cav. divs.), lay by Luzna and Gorlice as far as Malastów. The Austrian III. Army, under Gen. von Boroewicz (24 inf. and a cav. divs.), stretched from Malastów in a salient curve S. of the Carpathian crest by Zboro to Wirwa. Thence the Austrian II. Army, under Gen. von Böhm-Ermolli (14 inf. divs.), held its position as far as the heights W. of the Uzsok pass. From here by Zawadka, on both sides of the Orawa and the Oportales, by the Wyszokow saddle to the sources of the Moloda, lay the Southern German Army, under Gen. von Linsingen (9 inf. divs.). Next came the Austrian VII. Army, under Gen. Baron von Pflanzer-Baltin (8 inf. and 5 cav. divs.), curving on the line Solotwina, Otynnia, Horedenka Zaleszczyki, and along the Dniester and the frontier.

On the Russian side there stood in the area S. of the Vistula, and on the Carpathian front, the III. Army (Gen. Radko Dimitriew), the VIII. Army (Gen. Brussilov), the Stry detachment and the IX. Army (Gen. Lechitski)—in all some 40 inf. and 16 cav. divs. with at least 10 Militia Opolchewie brigades.

*The Break-through of Gorlice-Tarnów (May 2-3).*—By the end of April all the preparatory measures for the offensive were complete, and on May 1 the preliminary bombardment on the front of Mackensen's Army Group began; this was followed at 6 A.M. on the 2nd by four hours' intensive fire by some 1,500 guns of all calibres on a scale far surpassing anything yet known. The Russian trenches, on which many months' labour had been expended, and which were sited with great skill, were soon so shattered that the infantry, who had advanced to assaulting distance, were able to storm them.

During the night of the 2nd the left-wing group of the IV. Army, the combined division under Field-Marshal-Lt. Stöger-Steiner, forced the line of the Lower Dunajec by a surprise attack, and during the day established itself at Otfinów on the eastern bank.

The vigorous offensive of the XI. Army, in which the Austrian VI. Corps specially distinguished itself, met with little resistance from the Russians, who had been completely overwhelmed by the bombardment. Between Cieżkowo and the heights S. of Gorlice their lines were completely broken through. The Austrian X. Corps, fighting on the left wing of the III. Army, had a large share in this success. By 7 P.M. it had stormed the Russian positions on the heights S. E. of Rada, Ruska, and E. of Malastów, and continued its advance until a late hour of the night.

The Austro-Hungarian IV. Army, which had to carry the very strong and defensible ridges of Dobrotyn and hills 419 and 402, was also in the end successful, after severe fighting, assisted in some measure by the effect of the XI. Army's break-through. Meanwhile the remaining Austro-German armies kept the Russians on their respective fronts constantly on the alert, and thus prevented any transference of troops; the Russian III. Army alone succeeded in concentrating strong reserves (III. Caucasian Corps and 63rd Res. Div.) in the vicinity of Jaszlo.

The offensive was continued on the 3rd with the utmost energy; the XIV. Corps stormed hills 419 and 402, while the IX. Corps on the right wing of the army captured the heights E. of Gromnik. Up to mid-day the XI. Army met with little resistance; in the afternoon, however, it came up against a series of strong positions, which were not captured till the evening, and its right wing reached Wapienne, the centre Biecz, while the left wing occupied the Lipie heights and the ridge N.E. of Opatyn. The left corps of the III. Army stormed Ostra Gora, the Russians in front of it establishing themselves on the E. edge of Magur.

By the 4th such rapid progress had been made that it was possible to extend the attack on the whole front of the III. Army;

The Army High Command ordered the XI. Army to continue its advance, with its reinforced southern wing moving in the direction of Dukla—Kracon—Strzyżów, the III. Army's left moving on Tylawa, its centre and right continuing to hoke the enemy in their front. The time for the assumption of the offensive was to be at the discretion of the army commander himself. The neighbouring army under Böhm was already assigned as a reinforcement of the left wing, to operate in harmony with Boroewić's right wing.

The left wing of the IV. Army was heavily attacked on the night of the 4th–5th, and little progress was made by it or by the German 47th Res. Div. in the course of the following day. On the other hand, the Russians opposed to the XIV. Corps, in the centre of the IV. Army, fell back before dawn; both divisions of the corps followed them up closely, and by nightfall had reached the line of the Biala. The right corps captured the heights N.E. of Tuchów and Dobrotyna hill. The XI. Army made very rapid progress on this day, driving the enemy back step by step as far as the Wisłoka, and establishing itself at Pilgrzymka Osobnica and Olpiny in close touch with the IV. Army.

On the left wing of the III. Army the 21st Landwehr Inf. Div. occupied the heights of Watkowa after heavy fighting.

On the 5th, however, the resistance of the Russian III. Army was still unbroken. The IX. Corps, indeed, captured the heights of Obarz and Wiszowa, thus securing possession of the whole of the Dobrotyna ridge, while Szende's brigade and the 106th Inf. Div., in the face of stubborn resistance, cleared all the area E. of Tuchów as far as Zalasowa and the heights of Trzemesna W. of it, while the 3rd Div. succeeded in crossing the Biala; but the 8th Div., which finally followed the 3rd over the river, and the whole of the northern wing of the IV. Army, were unable to gain any success.

On the right wing of the XI. Army, however, Gen. von Emmich's corps, which had pressed far forward, again met with great success, throwing the Russians back behind the Jasiołka in the direction of Dukla, while the left wing of the army advanced to Jodłowa.

This rapid advance naturally facilitated the task of Boroewić's army. As early as the morning of the 5th the front of the XXIV. and XII. Russian Corps, before the centre and left of that army, began to yield. Pursued by the Austro-Hungarian X., XVII. and VII. Corps in the direction of Jaslika and the upper valley of the Laborca, they were driven into the area W. of Tylawa behind the valley of the Ondawa and onto the heights N.E. of Nagybakoczy. Only the XXI. Russian Corps held its ground at great cost against the German Beskidén Corps, fighting on Boroewić's right wing.

On the N. wing of the IV. Army the enemy's resistance was at length broken on the night of the 6th by the repeated assaults of Stöger-Steiner's Div. and the German 47th Res. Div. While the Russians evacuated their positions below Tarnów as far as the Vistula, the Austro-German troops occupied Tarnów and initiated a pursuit in the area W. of Pilzno.

The right wing of the IV. and the left and centre of the XI. Army had meanwhile reached the Wisłoka. Emmich penetrated as far as Wietrzno with his corps, and in the Dukla area blocked all the lines of retreat leading N. and N.E., along which Radko Dimitriew's defeated columns were now retiring in wild disorder. At Tylawa the Austro-Hungarian X. Corps, advancing from the W., encountered the 48th Inf. Div. of the Russian XXIV. Corps under Gen. Koronilov, and in conjunction with Field-Marshal-Lt. Berndt's Cavalry Div., forced the greater part of it to surrender and scattered the rest, who were captured some days later by Emmich's troops.

By the evening the Austrian XVII. and VII. Corps had reached the Dukla pass and the Laborca valley, driving before them Radko Dimitriew's broken right wing, which took refuge behind the Jasiołka and the Carpathian ridge, leaving behind many prisoners and vast quantities of war material.

In view of these successes, it was to be expected that the Russian XXI. Corps would shortly be compelled to evacuate the Lupków pass which would shake the whole Russian front along the Carpathians to the E. of it. The rolling-up of this line seemed to ensure the complete strategic success of the five days' "break-through" battle of Gorlice-Tarnów in which Radko Dimitriew's army had been driven back more than 20 m. on a front of 100 m., with a loss of 50,000 prisoners, 50 guns and much other material.

**The Pursuit and Battles at Sanok and Reszów (May 6–11).**—After his severe defeat, Radko Dimitriew's plan was to hold the Lupków pass with his left wing, and, supported upon this, to bring the pursuit to a stand on the line Nowotaniec-Besko-right bank of the Wisłok, where there were positions favoured by the lay of the ground, and then, between the Vistula and the Wisłok, on the line Wielopole-Zassow-Malec. Here he proposed to reconstitute his units, which had fallen into great disorder, and to strengthen them by bringing up reserves. Troops were sent to him from other fronts, and by the 8th he could again dispose of 18 inf. divs., 5 cav. divs. and 5 Reichswehr bodies. The orders were that the offensive was to be continued with all possible vigour; Mackensen's army was to push forward over the stretch of the Wisłok between Besko and Fryszak on Mrzyglód and Tyczin, and the Archduke Joseph Ferdinand on Reszów, while Boroewić was to roll up Brusilov's VIII. Russian Army in the direction of Sanok. Böhm's II. Austrian Army was to join up corps by corps from the left wing in proportion to the progress of the attack.

In the course of the 8th the Russian positions were once more attacked along the whole front, and in the sector of Mackensen's army were stormed along the whole E. bank of the Wisłok. Both here and in the front of the centre and right of the IV. Army the fighting was heavy; the Russians were driven by the latter from Pilano and Brozatek, and pursued beyond Debica and the hill of Chelm. In front of the newly formed group under Gen. von Kirchbach, composed of Stöger-Steiner's Div., the German 47th Res. Div. and certain Landsturm formations, on the left wing of the IV. Army, the Russian IX. Corps fell back in the afternoon to the new line prescribed.

Meanwhile, Boroewić had also pressed the Russians hard and by 3 A.M. forced them to abandon the Lupków pass as well as the strong Bokuwka ridge, and to retire to the line Zarzyn-Bukowko-Saczawa, where they once more took up strong positions. As a natural result of the retreat of the III. Russian Army, the whole of Brusilov's VIII. Army began to give ground, and Böhm's army with the W. wing of Linsingen's, at once took up the pursuit.

On the 9th, however, violent resistance was once more encountered, particularly on the fronts of the German Southern Army and the Austro-Hungarian II. and III. Armies, from the Ostry hill to Besko. The Russian point *d'appui* at the latter place was much endangered by the withdrawal of the Russian front fighting against Mackensen's left flank of the Stobnica, but it was urgently necessary to hold it, as also the strong front Bukowko-Saczawa, in order to secure Brusilov's undisturbed retreat. Despite a violent counter-attack delivered by three newly arrived divisions astride the Sanok road between Besko and the left flank of the Russian line on the Stobnica, the Russians were forced to abandon Besko on the evening of the 9th.

When on the 10th Böhm's left wing, pressing forward by Bałgrad and the San, captured Szczawa, and the gallant X. Corps Boroewić's left took Zarzyn, the strong position of Bukowko became untenable; and by the evening of the 11th the Russian flank fallen back behind the San. The III. Army followed them up to the area Sanok-Zagorzec. Meanwhile the XI. Army had stormed the Stobnica position and advanced its front. Of the Archduke Joseph Ferdinand's army Kirchbach's corps on the evening of the 11th reached the Lower Wisłok while the centre took Sedziszow. During the night of the 12th the IX. Corps secured Reszów.

The Russians, after some minor rear-guard actions, had also fallen back along the whole front before the II. Army, so that at the 11th the Austrian left wing had reached the whole area, while the right had pushed the Upper San, where the Southern Army was.

At this point may be said to have ended the battle of Reszów-Sanok, the effects of which were quickly seen in the retirement of the enemy line N. of the Vistula. The Russians now prepared to make a fresh stand on the strong defensive line of the San below Przemysl, where they had constructed strong lines of defence, with their flanks resting on the Dniester marshes at Wielki Błot, and the angle made by the Vistula and the San. Up to this point they had lost 130,000 prisoners, 100 guns and 300 machine-guns.

**Events up to the Battle of Przemysl (May 12–31).**—The Russians, foreseeing the possibility of a further retreat, had chosen as their next position the line of the San below the fortress of Przemysl, which had again been placed in a state of defence, as far as Nisko, and they had strengthened this line by the construction of bridge-heads at Radymano and Jaroslaw. Below Nisko the line enclosed the angle formed by the Vistula and the San, whence a particularly strong line of defence led to Tarnobrzeg and was continued on the far side of the Vistula to Kłomocin and Opatów. The southern front was connected by an equally strong fortified line through Husaków and Krukienice with the Dniester, which served as the next natural line of defence for the Russians. At first, however, they did not make full use of this river as an obstacle, since they advanced their IX. Army against Pfanzer-Baltin to the Pruth.

The immediate object of the Austrian and German High Commands was to force the San below Przemysl, and to attack that fortress. The following objectives were assigned to the armies. The IV. Army was to force the Lower San, and the XI. to pass that river on either side of Jaroslaw. The N. wing of the III. Army was to push forward S. of the San against the W. and S. fronts of Przemysl, and secure that place by a *coup de main*, while its S. wing advanced by Dobromil on Moszczka. To the II. Army was assigned the direction Chyrów-Sambor, while the Southern Army's objectives were Drohobycz and Stryj. The VII. Army was to maintain its positions, while on the N. of the Vistula the armies of Daak and Woyrach were to follow up the enemy, with their inner flanks moving by Dalezycze on Supia.

After breaking off the battle the Russians had rapidly fallen back to the San, and were as rapidly pursued. The pursuers encountered in the main only a few small rear-guards during the next few days; the II. Army, however, had violent fighting at the San crossings, and on the III. Army from the 27th Div. in conjunction with the German Beskidén Corps, dispersed a hostile rear-guard on the heights of Magiera, S. of Przemysl.

On the 14th the German Guard Corps found itself face to face with the strong fortifications of the bridge-head at Jaroslaw. After a short but intense preliminary bombardment the Guard infantry, assisted by those of Field-Marshal Arz's Corps advancing from the

S.W. stopped the works on the 15th, and on the 16th entered Jurdów and crossed to the E. bank of the San.

The IV. Army reached the Russian lines on the Vistula-San angle on the same date, and took up a position on the W. bank of the San as far as the Wisłok. S. of the Wisłok the XI. Army had established itself on the left bank of the San, in face of the fortress girdle of Przemysł and extending to the San S. of Mackowice; the III. Army aligned itself as far as Husaków before the S.W. and S. fronts of Przemysł, while the II. Army had worked its way forward to the entrenched line extending over Krulicnice to the Wiedki Błoto. S. of this marshy area the Southern Army had driven Cherbabchew's XI. Russian Army back on Stryj and Dolina, which had been formed out of the Stryj detachment early in May. Pfanzar's Army was compelled to withdraw before the Russian IX. Army (Lochitki) to the Pruth between Czerwonits and Kolomca, and there made preparations to hold this line, while cooperating with its reinforced left wing in the offensive of the Southern Army.

N. of the Vistula the Russian IV. Army was forced back by the armies of Dankl and Woyrsch to the line Nowe Miasto-Mniszek-Łlza-Opatów-Klimontów, after heavy fighting in the Czarna and Łysa Góra areas, and small rear-guard actions elsewhere. Before the IX. German Army, the Russians held their ground.

In 14 days of fierce battle the Central Powers had gained a great victory, and had pushed back the Russian "steam-roller" some 120 mi. eastwards, besides securing 170,000 prisoners, 128 guns, 368 machine-guns and immense quantities of war material.

A pause in the operations now ensued, which was devoted to the preparations for a further offensive, to compromise the forcing of the San line, the capture of the fortress of Przemysł, and the storming of the heights S.E. of the fortress.

The San itself at this season was not a serious obstacle, and its passage presented no difficulties in itself; but on the far bank there existed strong and well-prepared positions, while the Russians had received considerable reinforcements; their front E. of the Vistula having been strengthened by some 9 divs. at the beginning of May. The fortress of Przemysł had been reconstructed by the Russians and was now too strong to capture by a *coup de main*. The bringing-up of heavy artillery would therefore be necessary, and the strong positions S.E. of the Vistula also demanded a carefully planned attack. It appeared, moreover, that the Russians had recovered their breath in this new position, and that they intended to oppose an energetic resistance to the pursuit. Fresh and thorough preparations had, therefore, to be made for the continuance of the attack. The transport of supplies could not keep pace with the troops during their rapid advance, for the Russians in their retreat had carried out a thorough work of destruction. The roads and railways could not be used, and the bridges had been blown up. Only after hasty restoration had been carried out could the necessary heavy artillery and ammunition be sent forward.

As the front became shortened during the advance, the Austrian VIII. Corps was on May 10 taken out of the line on the III. Army front, transferred by rail to the IV. Army, and attached to Kirchbach's group where it was to be assigned the part of storming Sandomierz. The 41st Honved Inf. Div. was also transferred from the III. to the I. Army, coming into line on the 19th at Staszów.

The imminent entry of Itagy into the war had no influence on the continuance of the offensive, apart from the fact that the VII. Corps (17th Inf. Div. and 20th Honved Inf. Div.) were entrained on the 21st at Mezi Laborca for the S.W. front. There was, however, a spontaneous pause during which both sides made their preparations for the forthcoming great battle. The Austro-German troops were engaged on their front in securing favourable conditions for their impending attack, while the Russians endeavoured, in a series of powerful counter-blows, to check the progress of their pursuers and even to prepare the ground for a possible offensive.

The occupation of Jarosław early on the 16th, and the construction within the next few days of a regularly fortified bridge-head, in which was included the village of Seniawa, captured on the 18th by the Austro-Hungarian 10th Inf. Div., afforded a favourable saltpoint for the next advance. Despite the gallant counter-attacks of the III. Cavalian and XXIV. Corps, the German X. and Guard Corps and Austria's Austrian Corps were able to consolidate their positions in this sector. The 12th Div. of the last-named corps on the 20th carried out a successful advance towards Radymno. The XI. Army Command, in order to assist the II. and III. Armies, which were making little headway, projected an attack on the 24th with the left flank along the Skoko on the E. bank of the San. If the part played by the Russians opposed to the XI. Army was mainly passive, they showed a more aggressive spirit opposite the IV. Army on the Lower San. Units of their IX. Corps near Miśko, and of their X. Corps near Stare Miasto, delivered violent attacks on the 28th, which were defeated. On the 19th, after being reinforced they again crossed the San between Rudnik and Stare Miasto but had to return hurriedly to the E. bank as the result of a counter-attack by the 3rd Inf. Div. Heavy fighting also occurred near Rudnik, where the 8th Inf. Div. defeated with the utmost gallantry the repeated Russian efforts to effect a break-through.

During the pause in the fighting here, violent fighting took place in the bend of the Vistula on the front of Dankl's and Woyrsch's

armies. The pause, which had been begun on the 12th by the former army, had been successively taken up by Woyrsch's armies and by Kövess's army group. The right wing of Dankl's army encountered strong resistance on the 16th on the line Koprzywnyca-Klimontów, advanced to the attack but failed to break through; the same fate befell the II. Corps on his left wing, which had to relinquish its initial gains in face of a violent Russian counter-attack. Woyrsch's right wing, which was in touch, was also held up; on his left wing, however, the 16th Inf. Div. took Ruski Brod near the source of the Radomka and drove the enemy back in flight.

During the 17th indications of a Russian counter-offensive between the inner wings of Dankl's and Woyrsch's armies increased in number, and Bredow's div. (Woyrsch's right wing) and the II. Corps actually had to resist a series of violent assaults which, in the case of Dankl's army, even suggested the necessity of a retreat behind the Czarna. On the 18th, however, the expected counter-offensive failed to materialize against Dankl's left wing; the Russians devoted all their efforts on this and the following day to the capture of Bredow's positions, and they also exercised considerable pressure against Dankl's southern wing; all their attacks, however, were beaten off.

On the 20th the main body of the Austro-Hungarian 7th Cav. Div. came into action on Bredow's right, and the 41st Honved Inf. Div. from the III. Army, on the II. Corps' left; and the Russians in this part of the front thereupon fell back before this corps and Bredow's div. to an entrenched position on the line Brody (on the Kamienna)-Wasniów-Kobylany. The pursuers worked forward to this on the 24th. Nothing of moment occurred in the centre and on the northern wing of Woyrsch's army, or on the fronts of Kövess's army group and the German IX. Army.

The Russian attempt to break through in the mountain area N. of Kielce, to relieve the pressure on their retiring troops N. of the Vistula, had thus failed; 6,300 prisoners had been lost.

S. of the Vistula there now began the violent struggle prepared for since the 12th, which in the battle of Przemysł, was to introduce the second phase of the great spring campaign in Galicia.

*The Battle of Przemysł (May 24-June 6).*—On May 24 the attack by Mackensen's army, which had been planned four days earlier, began along the Skoko in an E. and S.E. direction. At the same time the II. and III. Armies were to advance in a N.E. direction along the Mosćka-Przemysł road, with the object of driving the Russian field army away from the fortress from the S. The IV. Army, securing the San crossing at Seniawa, was to direct its main effort against the strong Russian positions in the angle between the San and the Vistula about Rudnik and Machów, while the Southern Army was to continue its attacks in the Droboczek-Stryj area. As early as the 24th the XI. Army forced back the enemy along all the front of attack. The German XLI. and Austro-Hungarian Corps on this and the following days, accomplished the brilliant feat of storming Radymno, which the Russians had erected into a powerful bridge-head by means of three exceptionally strong lines connected with the northern defences of Przemysł.

A violent and extremely effective artillery preparation begun early in the morning made it possible to take Ostrów and Radymno on the 25th, and finally for the VI. Corps to capture the bridge-head of Zagrody. The Russians fled over the San in complete disorder. By the premature destruction of the bridge over the river, 21,000 of them were cut off, and fell into the hands of the victors, who also captured 39 guns and 40 machine-guns.

By the evening of the 25th Mackensen's attacking wedge had been driven forward on the E. bank of the San to the line Radwa-Zapalów (on the Lubaczowka)-Laski-Lazy. On the W. bank the Bavarian 11th and German 119th Divs. had already on the 24th reached the heights S.W. of Zablotce. On the 26th the XLI. Corps succeeded in gaining possession of the S. end of Swiete on the W. bank of the San, while the VI. Corps took the villages of Nienowice and Chotyńiec. The Guard established itself on the line Zaleska Wola-Zapalów.

The Russians had made every effort to check Mackensen's advance, particularly by means of violent counter-attacks at night, but in vain. Mackensen's advance had progressed so far to the E. that Przemysł was now encircled from the north. He proceeded to consolidate his positions in this area, partly in order to counter a Russian offensive which was just beginning, partly in order to await the moment when the II. and III. Armies should be able to deliver a direct assault on Przemysł from the south.

The right wing of the II. Army and the whole of the III. continued their attacks on the 24th with the utmost energy. On the previous night a Russian counter-attack had pressed the XVIII. Corps back a little, but on the morning of the 25th the position was restored, largely owing to the arrival of the 13th Landwehr Inf. Div.

Field-Marshal-Lt. Schmidt's group (7th Inf. Div. of the IV. Corps and the XVIII. Corps), attacking on the left wing against Mosćka, gained some small successes, but the German Beskiden Corps farther to the left made no advance on this day. On the 26th it was able to storm two hills near Husaków, but as against this all the efforts of Schmidt's group broke down before the strong Russian positions, which were in part concreted and consisted in places of seven successive lines of trenches. Owing to the lack of heavy artillery the attack here could progress only by systematic

sapping, and in this manner it had, by the 28th, worked its way up to the Russian wire entanglements.

Meanwhile the Russians had resolved on a counter-offensive with superior forces against the S. wing of the IV. Army. Their plan was to advance from the N. and N.E. over the San at Sieniawa and to the N.W. of it, and thus to put a term to Mackensen's progress.

On the 27th the strongly reinforced III. Caucasian Corps (Gen. Irmanov) delivered a surprise attack upon the Sieniawa bridge-head. The Austro-Hungarian 10th Div., consisting in part of untrustworthy Czech troops, gave way, and was thrown back to the W. bank of the San and the Lower Lubaczówka, losing 9,000 prisoners, 9 guns and 4 machine-guns. Strong reinforcements hurried forward from other divisions succeeded in stiffening the badly weakened right wing of the army on the W. bank of the San, and in averting the menace to Mackensen's left flank. On his front also the Russians on the 27th delivered unexpected, but unsuccessful attacks against the Lubaczówka and the positions of the VI. and XLI. Corps at Chotyniec and Starzawa.

On the 28th the Russians renewed their attacks in this area and on the San. On the Lubaczówka they succeeded in penetrating the lines held by the German X. Corps, but were driven out by a flanking movement. On the next day they again delivered strong assaults in the Sieniawa area and made vain attempts to pass the San.

The N. wing of the IV. Army, in conjunction with the I. Army on its left (now under Kirchbach, in place of Dankl, who had been appointed to the command in Tirol), moved forward on the 24th to attack the fortified line Machów-Rudnik, and by the 26th had forced the Russians back to the S. of Grębów. The Russian attack at Sieniawa, however, necessitated the immediate withdrawal of forces to strengthen the right wing of the IV. Army and the cessation of the N. wing's offensive. On the 30th, therefore, there was a temporary cessation of activity; at the same time indications were observed of a renewed Russian blow against the inner flanks of the IV. and XI. Armies. The Supreme Army Command gave expression to this fear in instructions to these armies to devote special care to the strengthening of their positions and to hold reserves in readiness on their threatened wings. The III. and II. Armies were meantime to pursue their attacks.

During the following days, from May 30 to June 3, Przemysl was stormed (see PRZEMYSL). Throughout this period hard fighting was also taking place immediately S.E. of the fortress and on the San between Przemysl and Rudnik. In the latter area it was the Russians who took the initiative. Since the capture of the Sieniawa bridge-head by the III. Caucasian Corps, it became clear that strong forces were being concentrated against the XI. Army, and that the Russian IX. Corps in the Ulanów-Rudnik area was being reinforced. The XIV. and XV. Corps of the Russian IV. Army had been brought over the Vistula to the area Sandomierz-Nisko.

In front of the Austro-Hungarian IV. Army and the northern wing of the German XI. Army (in all, 114 inf. and 2 cav. divs.) stood the whole of the Russian III. Army (some 20 inf. and 4 cav. divs., with 6 militia brigades). The Russians appeared to be planning an energetic counter-attack; on June 2 the Austro-Hungarian IX. and XIV. Corps had to repulse heavy attacks and to prevent attempts to cross the San.

On the evening of June 1 the 8th Inf. Div. on the left wing of the XIV. Corps W. of Rudnik had been hard pressed and forced to fall back to its next line of defence; all attacks on the 2nd were beaten off, but there was danger of a Russian break-through just W. of Rudnik, as the whole XIV. Corps in conjunction with the IX. Corps had been pressed back to the line running from the heights W. of Tarnogóra, by Jezowa to Jata, where it came into touch with the right wing of the VIII. Corps which was bent back on the line Sianý-Przysów. In the case of this latter corps nothing worth mentioning occurred. All attacks on the Lubaczówka were repulsed by the German X. and Guard Corps, on the northern wing of Mackensen's army.

On the following day the IV. Army front continued quiet, the troops fortifying their new defensive line, which was not attacked. The fall of Przemysl having freed troops of the III. Army for use elsewhere, the Austrian X. Corps (24th and 25th Divs.) was hastily dispatched to Lancut and Rzeszów, to reinforce the IV. Army. Troops were also dispatched to the XI. Army, the German 22nd Div. to Lancut, the 8th Bavarian Div. to Radymno, the German XXVI. Corps to Jaroslaw, and the 107th Div. to Przeworsk.

On the 4th the Russians renewed their massed attacks against the IV. Army, but these were all repelled with heavy loss. The 59th Regt. near Tarnogóra repulsed an attack by the four regiments of the Russian 61st Inf. Div. The northern wing of the XI. Army also dealt successfully with a series of Russian attacks delivered as late as the night of the 4th. On this day the Russians' power of attack seemed to have exhausted itself. They had suffered enormous losses and the driving-back of the Austro-Hungarian XIV. Corps was the only success they had to show. Only on the 6th did strong forces from the Russian VIII. Army once more attempt a counter-attack on Mackensen's eastern front, but this did not succeed in preventing the establishment of the XLI. Corps on the line Starzawa-Czerniawa. On the front of the IV. Army all was quiet on June 4. The Russian plan of holding the San line, and relieving

their hard-pressed VIII. Army by a powerful counter-offensive in the Rudnik area, had thus failed.

While Przemysl was being invested and captured Puhalló's and Böhm's armies were engaged with Brusilov's left wing S.E. of the fortress. The former had taken over the III. Army from Borovik, who on May 24 was put in command of the V. Army against Italy. Early on June 2 Böhm made an energetic attack in conjunction with the German Beskiden Corps on the right wing of the III. Army, but on this day met with no success. Only by slow degrees and step by step could the divisions of the II. Army work their way forward up to the strong hostile positions. On the 3rd the Beskiden Corps succeeded in breaking through the Russian lines at Husaków and in establishing itself on the heights W. of Mysiatyce, while the divisions of the XVII. Corps in touch with it to the N. gained a firm footing on the crest N.W. of Husaków. The success of the attack was greater on the 4th. In conjunction with the XI. Army the XVII. Corps pushed forward to the heights E. of Wola Łocka, and there met with strong resistance. The Beskiden Corps was engaged by the evening against the hostile positions W. of Czyski and N. of Rakocz (S.W. of Mościska), where it connected with the left-wing corps of the II. Army, which had itself done excellent work in the area to the S. of the Beskiden Corps and in conjunction with it.

*Battle of Stryj, and Fighting on the Pruth and Dniester (May 24-June 15).*—Simultaneously with the attacks of the IV., XI., III and II. Armies, there began on May 24 on the German Southern Army front a 48 hours' intense artillery preparation, which was followed by the actual attack on the morning of the 26th. The line of Linzinger's army extended from Hruszów on the Bystrzyca E. of Drohobycz, S.W. of Stryj, and E. of Rolebów to the Dolina etc. The 5 inf. divs. of Stöcherbacher's XI. Russian Army were opposed by 8 inf. divs. and 3 independent brigades.

The results of the first day's operations were brilliant. Field-Marshal Saurmay's corps on the left stormed the hostile position at Gaje, while the 38th Hooved Inf. Div. and the left wing of Count Bothmer's German Corps in touch with it, pressed forward successfully before Stryj. Hofmann's Austro-Hungarian corps also made progress N. of Dolina. Gen. Geroch's XXIV. German Reserve Corps fighting on the right wing to the S.W. of Dolina, on the other hand, beat off all attacks. As on the second day, however, the Russians everywhere maintained their strong positions with the utmost stubbornness, the attack was brought to a standstill, and recourse had to be made to sapping, as on the II. Army front.

During the next few days the Russians endeavoured to clear their front by a series of strong counter-attacks mostly delivered by night against Hofmann's Austro-Hungarian corps; and they succeeded by the morning of the 30th in forcing it back behind the Smica to the line Lisowice-Hosów. Here, however, their progress was checked by Hofmann and the 24th Reserve Corps.

On the 31st Bothmer's energetic attack on Stryj turned the scale of victory in favour of the Southern Army. Advancing in conjunction with Saurmay's S. wing from the Holobutów area, he defeated the enemy, taking 9,050 prisoners, 8 guns and 15 machine-guns; and, pushing on through Stryj, established himself on the line Lisowice-E. of Stryj-S. of Brigidau.

The effect of this was immediately felt on the Southern Army front. Saurmay's left wing, on June 1, stormed the Russian line N.E. of Drohobycz, and pursuing by Kolodrubny and Mikolajew, drove the enemy back on Medenice. The 1st Cav. Div. and 2 battalions of the II. Army, which had joined in the attack, were placed under the Southern Army. On June 2 Bothmer's corps took Lisiatyce, but its 1st Div., fighting E. of Stryj, made no progress. The 38th Hooved Inf. Div. and Saurmay's right wing during the night drove the Russians back to the Dniester.

The Supreme Army Command now proposed, while securing its flank on the Dniester, to push Bothmer's corps and the main body of Saurmay's corps eastwards towards Zurawno against the flank of the Russian IX. Army, thus relieving the pressure on Płanzer Baltin. The execution of this scheme produced excellent results. Yielding to Bothmer's pressure, the whole Russian line was in retreat early on the 4th. While Saurmay on the line of the bridge-heads of Mikolajew and Kolodrubny undertook to guard the flank facing the Dniester, Bothmer advanced on Zurawno with the 38th Hooved and German 1st and Guard Divs. By the evening Hofmann and Gerok, taking up the pursuit towards Kalisz, had reached the line Zawadka-Holyn. Here on the 5th the right-wing corps of the Russian IX. Army stood stubbornly at bay, while Bothmer was already preparing to force the Dniester at Zurawno, which he had taken by a coup de main. Meanwhile the 1st Cav. Div. had advanced by Tejszarow on Zydzaków, and on the W. flank Saurmay repulsed powerful counter-attacks by the Russian XXII. Corps.

On the 6th Gerok and Hofmann broke the resistance of Lechtala's right wing at Holyn and Zawadka, and pursued the XI. Corps, which had been in action there, by Kalisz on towards Worniszów. Bothmer, with the 38th Hooved Inf. Div. and the Guard Div., stormed the heights N. of the Dniester, and on the 7th, after violent fighting with parts of the Russian XVIII. Corps, forced the Russians to retire from Nowoszyn. The 38th Hooved Div. reached Bukaczowce that evening. On the 8th Hofmann's troops forced



the change of the Lomica, and pressed on towards Halicz and Jezupol, while Gerok entered Stanislaw.

The task of the Southern Army, to roll up the hostile line in front of Pfanzler's army by an attack eastwards, was more than fulfilled when it had reached the line Halicz-Stanislaw. The right wing of the Russian IX. Army had indeed been in retreat since June 9.

Pfanzler-Baltin's army had been forced back behind the Pruth by the Russian counter-offensive in the middle of May, and only at Kolomea did it continue to hold a position somewhat in the nature of a bridge-head on the N. bank. Its line ran from Delatyn, which it enclosed N.E. of Peczyn to the Perehinsko area, where it touched Linsingen's right. On May 21 the Russians had stopped their advance and entrenched themselves along their whole front: they had some 11 inf. and 8 cav. divs. as against 8 Austro-Hungarian inf. and 5 cav. divs., with 5 independent brigades. On June 1 they delivered an unsuccessful attack against Pfanzler's left-wing corps under Field-Marshal-Lt. Count Schönburg; and next day they turned against the neighbouring corps, the XIII., S. of Nadworna, which also held its ground. On the 3rd, however, the Russian and Rifle Div. managed to force a passage to the S. bank of the Pruth at Sadzawka, but was thrown back to the Pruth next day, after heavy fighting, by the hastily reinforced Eastern Group under Field-Marshal-Lt. von Czibulka.

In view of the change which had meantime taken place in the situation on the German Southern Army front, the Russians seemed determined to press forward in the direction of Delatyn, in order to secure a fresh success against the VII. Army and to put a stop to the Southern Army's progress. During the whole of the 5th they assailed the 5th Inf. Div. and Czibulka's group with the utmost violence, and forced the latter back to the line Mliodiatyn-Peczyn. By the evening, however, the Austro-Hungarian troops, reinforced by some battalions from the neighbouring groups and by the 8th and 10th Cav. Divs., succeeded in driving them back to the line Kiszawo-Mliodiatyn, and in holding this line until the 6th.

At noon on the 4th Pfanzler-Baltin, hearing that the Russian XI. Army was withdrawing on its whole front, issued orders to Count Schönburg, in command of his left-wing group, and to Gen. Baron von Rhenen, commanding the XIII. Corps, to assume the offensive, which would also relieve Czibulka's hard-pressed troops. Schönburg was to advance eastwards with his main body on Bohorodzany, and with his right wing on Solotwina, while Rhenen was directed on Nadworna and Krasna. By the evening Schönburg had succeeded in getting forward to the heights S.E. of Maniawa, and to the line Kryczka-Jablunka-Majdan-Krasna. His advance came to a standstill on the 5th, but by then the flank attack of the Southern Army had begun to make itself felt. During the 6th the Russian attacks on Rhenen's and Czibulka's front entirely ceased, and in front of Schönburg's group rearward movements suggested that the Russian front was about to be withdrawn.

On the 7th Pfanzler-Baltin assumed the offensive all along the line. The Russians were thrown back again over the Pruth at Sadzawka, and the 36th Div. pursued them on to the far bank. The XIII. Corps got well beyond Nadworna, while Schönburg continued his attack in an easterly direction, and by nightfall stood on the Bystrzyca Nadwornianska at Grabowice. Marschall's corps took Zablotow, and Korda's XI. Corps and the 5th and 6th Cav. Divs. crossed the Pruth below the confluence of the Czeremow. On the 8th Schönburg reached the Otynnia area, while Rhenen, Czibulka and Krautwald (III. Corps) reached the line Chlebiczysz-Korszow-Kamionka Wk-Gwozdziec and the area E. of Wolcokowce. The right wing was advancing victoriously beyond the Pruth between Czernowitz and Sniatyn.

The 9th saw further successes; the centre and left wing forced the Russians back from the line of heights N.E. of Otynnia and Obertyn and S.W. of Horodenka. At this date Field-Marshal Lt. von Kaiser assumed command in place of Gen. von Marschall, who had been appointed to a command in the Southern Army.

Meantime, however, events on the Southern Army's front had taken an unfavourable turn, which had its repercussion on the operations of the VII. Army. Gerok's corps and the German 5th Cav. Div. had to be detached from the right of the Southern Army to its left, which was in a perilous position. This transfer, together with the fact that Schönburg and Rhenen were pushing eastwards, could not fail to create a gap in the area of Stanislaw which would involve considerable danger to the inner wings of the Southern and VII. Armies if the Russians became aware of it in time. The direction of the VII. Army's advance, therefore, had to be changed from E. to N. Schönburg and Rhenen were to move to the Mariampol-Nisniow area, Czibulka to Potok Zloty, Krautwald to Czernelica, Kaiser to the adjoining Zaleszczycki area, while Korda was to attack in the direction of Toporow.

The Russians had meantime resolved on a counter-offensive against the Southern Army. Bothmer's advance in the Zurawno area, the possible loss of the Mikolajow bridge-head, and an advance by the Southern Army in the direction of Lemberg, would have a serious influence on the Russian situation, both in the battle of Przemysl and on the Lower Dniester.

On the 7th the right of the XI. Russian Army reinforced by 2 divisions delivered a series of fierce attacks against Saurmay's group, which were driven back by the 8th to the line Derow-

Bilze-Medenice. At the same time a similar counter-blow was delivered against Bothmer in the Zurawno area; he held his ground successfully on the 8th, but on the morrow the superiority of the enemy on his front was so overwhelming that he withdrew to his old positions behind the Dniester. Saurmay's group also, attacked on both wings, had again to retire, and was withdrawn to the line Ruda-Tejszarow-Wolica-Letnia-Dobrowlany-Hrusow.

Faced with the urgent necessity of assisting his hard-pressed left wing, Gen. Linsingen left on his right wing before Stanislaw and Halicz only Marschall's group and Hofmann's Corps. Gerok's corps (10th Inf. Div. and 38th Honved Inf. Div.) was entrusted with the defence of the Dniester between Ostrow and Zurawno, while Bothmer, with 1st Inf. Div., the 3rd Guards Div., the 48th Reserve Div., and the 40th Honved Inf. Div., counter-attacked from the Salatyce-Zurawno area in the direction of Ruda and Zydaczow. Meanwhile Saurmay's group, covered on its left by the 4th Cav. Div., had, without any assistance from other troops, forced back the enemy to Litynia, and assumed the offensive all along its front.

On the 11th the 1st Inf. Div. stormed Zurawno, and the 3rd Guard and 40th Honved Inf. Div. approached Zydaczow, while Marschall's group repulsed all attacks on Stanislaw, and Hofmann's Corps prepared to carry Halicz.

The Russians, however, who had observed all their preparations, were ready with the necessary counter-measures. Reinforced by contingents from the VI. Corps, they made an attempt to break through Saurmay's front along the road to Stryl, but all their attacks failed. On the 4th, reinforced by two new divisions (33rd and 44th) of the XXI. Corps, they again attacked all along the front, and Saurmay's troops had once more to be withdrawn.

Meanwhile, the VII. Army's offensive operations had met with great success. On the right wing Korda's corps threw the Russians back over the heights of Brdo Horodyszczca on to the Besarabiah frontier, while Kaiser's group, despite fierce resistance, took the village of Zaleszczycki and reached the N. bank of the Dniester at Zrazawa; the centre stormed the heights S. of Czernelica, while Rhenen and Schönburg on the left wing occupied Jezlerzany and the area S. of Tysmienica.

On the 12th these two corps crossed the line Tysmienica-Tumacz, and then moved against the fortifications of Nisziow, which were stormed after a short artillery preparation on the 15th. On this date the S. bank of the Dniester was in German-Austrian possession from Mariampol to Kosmierzyn, where units of the 15th Inf. Div. (XIII. Corps) crossed to the N. bank. After a short but violent resistance the Russians were driven back, and the advance was resumed on Potok Zloty.

Korda's corps on the 12th drove the Russians over the frontier, and pursued them by way of Chotin and Wladczina to beyond Nowosielica. During the pursuit the 6th Cav. Div. encountered hostile resistance at Raszkow, which was quickly overcome. As any further penetration over the frontier, however, involved the danger, not only of being repulsed, but also of being repulsed, and of opening wide a gap in the line near Zaleszczycki, the Austro-German front was withdrawn over the frontier on the 15th.

A favourable influence on the situation on the right wing had been exercised by the break-through achieved by Mackensen's Army Group, after the battle of Przemysl, at Mocsiska and Lubaczow.

The Break-through at Mocsiska and Lubaczow (June 15-15). After the fall of Przemysl, the armies of Mackensen, Puhall and Bohn pursued Brusilov's army with rapidly succeeding attacks until June 5. On the heights W. and S.W. of Mocsiska, as far as Wielki Bloto on the one hand and on the Middle and Lower Lubaczowka on the other, Brusilov hoped again to hold up the Austro-German advance. After Mackensen's capture of Starzawa on the 5th the attack came to a standstill before the strong Russian positions. Here, as before Przemysl, the II. Army had recourse to sapping, which by the 12th brought it sufficiently far forward for the assault of the enemy lines.

Mackensen had now assumed command of the IV., XI, and II. Armies; the III. Army had been broken up, its X. and XVI. Corps going to the II. Army after the fall of Przemysl, and the Bezkow Corps to the II. Army. He determined to make use of the breathing-space for a thorough preparation of the attack. Reserves had to be brought up to strengthen the armies, which in the matter of material also had to be made again fit to take the field by bringing up a sufficient store of munitions and by establishing a new base of supplies. Mackensen's Army Group was organized on June 10 as follows: The IV. Army (Archduke Joseph Ferdinand) stood on the front field by it during the Russian counter-offensive; the VIII. and XIV. Corps on the left wing to S. of Tarnogora; the XI. Corps, brought up from the III. Army, extended thence to Stare Miasto, and the IX. Corps from Stare Miasto to the Wislok. S. of that river as far as the heights at the confluence of the Lubaczowka, stood the XVII. Corps, also from the III. Army. The total strength of the Army amounted to 14 inf. and 13 cav. divs. From the Lower Lubaczowka to S. of Czerniawa by way of Zapalow, E. of Chotytno and Starzawa, the XI. Army held the line. It was composed from N.W. to S.E. of the combined corps, the German X., XXII, and Guard Corps, the Austro-Hungarian VI. and the German XII. Corps. In all 14 inf. divs. The positions of Bohn's II. Army, which adjoined it, extended from S. of Czerniawa in a circle W. of and S.W.



of Mosiska to the S. edge of the Wielki Błoto. This Army comprised the Beskidn Corps, the Austro-Hungarian IV., XIX., XVIII. and V. Corps—14 divs. and 1 Landsturm Hussar brigade.

The Russian front was held by the III. Army from the Vistula to the upper Lubaczówka S. of Zapałów, and by the VII. Army thence to the Wielki Błoto. In all there were 41 inf. and 6 cav. divs. and 9 Reichwehr brigades of which, however, on June 14 two divisions of the XXI. Corps had been transferred to the E. bank of their XI. Army for the counter-offensive against Sarmay.

The general attack by all three armies began on the 13th. That of the IV. Army opened at 5:40 A.M. on the 12th with a powerful artillery preparation against the Russian positions at Sieniawa. In the course of the day Lt.-Gen. Behr's combined corps on the N. wing of the XI. Army succeeded in passing the Lubaczówka, and the Austrian 26th Landwehr Inf. Div. crossed the San at Ubiczyna and Lezachów, S. of Sieniawa, and finally got possession of the last-named place, which was held despite Russian counter-attacks.

At dawn on the 13th the XVII. Corps stormed the strong points of the hostile line at Sieniawa and Jukowa Gora, E. of it. These strong points were technically strengthened. Units of the IX. Corps had meanwhile passed to the E. bank of the San, including the whole of the 10th Div., which came into action in support of the XVII. Corps. On the same day Mackensen and Böhm opened the main attack. The Austro-Hungarian VI. Corps succeeded in pressing forward to Malastów, and to the N. of this the Guard advanced victoriously on Krakowice. On the other hand, the II. Army at first made little headway until in the night of the 14th the successes of the XI. Army on the previous day began to have an effect. As early as the evening of the 13th the Russians began their retreat, which on the morning of the 14th became general. On this day the XVII. Corps of the IV. Army pushed forward on Cerków and the IX. on Tarnograd, the northerly advance of the latter being intended to facilitate the advance of the adjoining X. Corps over the San. The objectives of the XI. Army were, to the E., the line Sakny-Krakowice, and to the N., in conjunction with the IV. Army, the area S. of Lubaczów. The II. Army was to advance beyond Mosiska. By the evening of the 14th the Russians had fallen back behind that town to a new defensive line which they had prepared on the heights W. of Sadowa Wisznia, at Krakowice and Oleszyce. This line, however, also fell on the 15th. On the previous day the VI. Corps had for the second time succeeded in breaking through the Russian front at Krakowice, and on the following day the German XXII. Corps did the same in the Niemirów direction, and the German X. Corps in that of Oleszyce and Lubaczów. On the IV. Army front the IX. Corps captured the *point d'appui* of Pioskorowice, while the XVII. Corps exploited its success at Sieniawa. The Russian resistance after a Ruma way in front of Böhm's Army, which on the 15th had stormed the Russian stronghold W. of Sadowa Wisznia. On the evening of the 15th and on the 16th, the Russians were in retreat along the whole front. They had once more been beaten decisively in the battles of Przemyl, Mosiska, and the Lubaczówka, and were now in full flight towards Lemberg. There existed now between the victorious Austro-Germans and the capital of Galicia only a single line of defence on the Grodek and Janów marshes of the Werezyna, on which the 1914 battles of Lemberg and Rawa Ruska had been fought, and on this line the Russians once more attempted to make a stand.

Their losses since the commencement of the spring campaign in Galicia had already amounted to no less than 971 officers and 391,000 men captured, with 304 guns, 763 machine-guns, and vast quantities of other material. (E. J.)

**DUNCAN, SARA JEANNETTE, MRS. EVERARD COTES** (1861—), British-Canadian author, was born at Brantford, Can., in 1861, the daughter of Charles Duncan, merchant, and married Everard Cotes, Anglo-Indian journalist, late managing-director of the Eastern News Agency, in 1890. She began her literary work as a journalist in connexion with the *Washington Post* and afterwards the *Toronto Globe* and *Montreal Star*, contributing to the latter letters from Japan and the East, afterwards republished as *A Social Departure* (1890). During her long residence with her husband in India she made a considerable reputation as a novelist of Anglo-Indian life, notably in *His Honour and a Lady* (1896); *Set in Authority* (1906); *The Burnt Offering* (1909) and *The Pool in the Desert*, a volume of short stories (1903). Her lighter work includes *A Voyage of Consolation* (1898); *Three Delightful Americans* (1902) and *His Royal Happiness* (1915), dramatized and produced in London March 1919. She also wrote *The Imperialist* (1904), a Canadian novel.

**DUNSANY, EDWARD JOHN MORSTON DRAX PLUNKETT, 18TH BARON** (1878—), Irish author, was born in London July 24 1878 and educated at Eton and Sandhurst. He entered the army, holding a commission in the 1st batt. Coldstream Guards, and served in the South African War. He was transferred

to the Reserve Royal Household Fusiliers and was wounded in the World War, April 25 1916. He unsuccessfully contested W. Wilts. in the Conservative interest in 1906.

Amongst his prose works may be mentioned *The Gods of Pagan* (1905); *Time and the Gods* (1906); *The Sword of Wellerman* (1906); *A Dream of Tule* (1910); *Tales of Woe* (1918); *Unhappy Few of Things* (1919); *Tales of Three Hemispheres* (1920). His plays include *The Glistening Gale* (1909); *King Argimenes* (1911); *The Gods of the Mountain* (1911); *The Golden Doom* (1912); *A Night at an Inn* (1916) and *If* (1921).

**DUPUIS, JEAN** (1828-1912), French traveller, was born at Saint-Just-la-Pendue, near Raonne, France, Dec. 7 1828, and was educated at Tarare (dept. Rhone). In 1858 he went to Egypt as a trader, and from thence to China. His trading journeys took him into many previously unexplored parts of southern China, and in 1871-2 his efforts opened up the Song-koi or Red river to commerce. The foundations of the French possessions in Tongking were thereby laid and Dupuis did much to assist in the conquest of the country (see 27.6 sec.). His explorations are described in the following works: *L'ouverture du fleuve Rouge au commerce* (1879); *Les origines de la question du Tonkin* (1896); *Le Ton-kin et l'intervention française* (1898) and *Le Ton-kin de 1872 à 1880* (1910). Dupuis was in 1881 awarded the Delalande Guérineau prize by the Academy of Sciences in Paris. He died at Monaco Nov. 28 1912.

**DURBAN, Natal, S. Africa** (see 8.696).—Pop. (1911) 34,830 whites and 53,118 natives, Asiatic and coloured. In 1911 the whites numbered 41,865 (with suburbs 48,413), natives (estimated) 26,000 Asiatics; and other coloured persons, 23,750; total 91,615. Durban's importance and prosperity depends upon its port (Port Natal), but since 1910 it has become a manufacturing place of some note. It is the most compact of the large S. African towns, the borough covering only 12 square miles.

Chief among modern buildings are the new Town Hall (opened 1910) and the Law Courts. The latter face the Victoria Embankment, a fine thoroughfare along Bay Beach, i.e. the Bay of Natal. At the Point, overlooking the eastern entrance to the harbour, an equestrian statue of Dick King, commemorative of his great ride to seek help for the infant settlement, was erected in 1915. From Ocean Beach a semi-circular pier, over 900 ft. long, encloses a bathing place free from sharks. Ocean Beach, with its esplanade and park and fine hotels, forms the chief attraction during the Durban winter season (May to Sept.) when the mean maximum temperature is 76° F. For horse-racing fixtures Durban ranks only second to Johannesburg among the cities of South Africa.

Vessels are constantly engaged in dredging the bar at the entrance to the harbour; the lowest depth of water at the entrance is 36 ft., the minimum depth at the quayside varies from 22 to 30 ft. The harbour is equipped with every facility for the rapid loading and unloading of ships. At Congella, at the N.E. end of the harbour, some 220 ac. of land had been reclaimed and 3,460 ft. of wharfage provided by 1920. Here timber and bulky goods are handled. Congella is also the centre for manufactures; it has cold-storage accommodation and does a large export trade. It was, however, the development of coaling facilities, made practicable by the nearness of the Natal coalfields, that placed Durban in 1913-4 above Cape Town as premier port of the Union. The coal bunkered at Durban, 1,196,000 tons in 1913, rose greatly during the war, but fell to 608,000 tons in 1918-9. In the same year, however, the export of coal rose to 704,000 tons compared with 261,000 in 1917-8. The rival to Durban for coal exports in South Africa is not Cape Town but Delagoa Bay, which exports the coal from the Transvaal mines. In 1918, in which year there was a great falling off in the number of ships visiting the port, the total tonnage of cargo landed, shipped and transhipped at Durban was 2,373,000—it had been 2,801,000 in 1916. In 1919 shipping increased, the total net tonnage entering the port being 2,999,000, of which 1,564,000 tons were British.

In 1910 a wireless station was opened at Durban; the first in South Africa. It has a normal range of 300 m. by day and 1,000 m. by night. In 1918—year ending July 31—the rateable valuation of Durban was £12,378,000, the revenue £1,095,000 and indebtedness £3,135,000. In that year the net profit on municipal trading was £110,000; in 1920 the municipal valuation was £13,546,000.

**DUVENECK, FRANK** (1848-1919), American painter (see 8.737), died in Cincinnati Jan. 3 1919. He was awarded a special gold medal at the San Francisco Exposition in 1915, and the same year he presented to the Cincinnati museum a large collection of his own works.

**DYING** (see 8.744).—The changes which occurred in the practice of dyeing during the years 1909-21 were not numerous

or important, any real progress having been checked by the World War, while in the rush to make up for loss of time post-war developments have also been few and far between.

As far as cotton-dyeing is concerned the most striking feature was the continued demand for the fast colours produced by means of vat dyes (indanthrene dyes, thioindigo red, etc.) which were introduced prior to 1914. These colouring matters, of which a wide range is now available, are being extensively used, in spite of their high price, for dyeing casement cloths, warp or weft threads to form the pattern in "grey" or unbleached piece goods which are subsequently bleached in the piece, and for the production of the fastest class of work in calico printing. Effects are thus obtained, even in bright colours and tints, in a degree of fastness formerly unknown, and this circumstance should go far to strengthen public confidence in the permanence of high-class coloured cotton goods.

Of colouring matters produced on the fibre, aniline black<sup>1</sup> is by far the most important, and is used in increasing quantity. This black may be produced on the fibre by different methods, but the one almost universally employed to-day is a modification of Lightfoot's original process patented as long ago as 1861. Commercially known as a "copper black," it is obtained by impregnating the material with a liquor containing aniline salt, copper sulphate and chlorate of soda, and, after ageing at a moderate temperature, running the goods through a hot dilute solution of bichromate of soda. This latter treatment constitutes the improvement on Lightfoot's process.

The production of insoluble azo dyes on the fibre, which was originated by Holliday in 1880 and has since been improved upon, is largely employed especially for the brilliant para-nitraniline red, a colour which also lends itself to the production of cheap but very striking resist effects in calico printing. The substitution of the amide of beta-naphthoic acid (naphthal A.S.) for beta-naphthol in the "prepare" may be regarded as a distinct recent advance in this class of dyeing, for the resulting colours are not only fuller and more level but the new colouring matters are theoretically about twice as strong as those obtained with beta-naphthol. A still further improvement has recently come about by which the number of operations required to produce the colour is reduced to padding and steaming. To this end the fabric is padded with a mixture of naphthal A.S. and a nitrosamine (the nitrosamine obtained from diazotized ortho nitro para-toluidine) and the colour developed by steaming in a rapid aera. It appears likely that this class of colour will have considerable application in the future.

Among the direct cotton colours a complete range is now available (of the benzo fast red and other types) which yield shades of remarkable fastness to light, a property which was rarely shown by earlier representatives of this class of dye. For goods such as casement cloths this property is naturally an advantage, for the colours are not only easier to apply than the vat colours but are considerably cheaper. It should, however, be borne in mind that although they possess fastness to light they are liable to bleed in washing as badly as their predecessors.

Other improvements in cotton-dyeing relate mainly to labour-saving devices in the dyeing of yarn. Dyeing in the cop, "cheese" or on the beam (for warps) is more largely practised than formerly and various appliances are employed for the purpose. The principle in all of these is, however, the same, i.e. instead of the yarn being moved about in or passed through the dye liquor, the material to be dyed is held *in situ* and the dye liquor is caused to percolate evenly by pumping or other suitable contrivance. It is easy to understand that only such colouring matters as can be obtained in perfect solution can be employed for this kind of dyeing. The process requires skillful management to get good results, but if such can be achieved with certainty it not only saves much labour but the yarn remains in a better condition. In hank dyeing and washing the turning of the hanks to ensure uniformity of treatment requires much hand labour. This is now largely dispensed with by the use of suitable machinery for the purpose.

As regards wool-dyeing no great changes have taken place in the ordinary run of bright and most fancy colours, which are mainly got with acid dyes. For blacks and browns and other sombre colours which were formerly dyed almost exclusively with mordant colours (and are still so dyed for the best class of work), two classes of azo dyes have come into prominence which are rendered faster by means of chromate or bichromate of soda.

Diamond black may be taken as a type of the first class. The wool is dyed with this colour in the ordinary way in an acid (acetic) bath, and at the end of the operation bichromate of soda is added to the

<sup>1</sup> Through an oversight the copper sulphate (10 parts) was omitted in the recipe given in 8,751. The total volume of the liquor (200 parts) should also have been stated.

bath and the boiling continued for some time, this additional treatment resulting in a considerable improvement in fastness and at the same time darkening the shade. Colouring matters of this type are known in the trade as "after-chromed" colours. The other class comprises the "meta-chrome" colours, and of these meta-chrome browns may be taken as typical. The dye-bath is made up with colouring matter, chromate of soda and ammonium sulphate. When the temperature of the bath approaches the boil ammonia is given off and the bath gradually becomes acid, causing both colouring matter and some of the chromium to be taken up by the fibre.

As in the case of cotton, machine-dyeing is now largely practised in dealing with wool in the loose state, in slubbing and in yarn. Here also a considerable saving in labour is effected and the valuable qualities of the fibre are much better preserved.

As far as silk-dyeing is concerned what changes have occurred are not of sufficient importance to merit special mention here. Artificial silk, especially that obtained from viscose which comes into the market in ever-increasing quantity, is dyed like cotton, but requires more care in manipulation since in the wet condition its tensile strength is considerably diminished.

*Effects of the War.*—During the years preceding 1914 Great Britain had been drawing roughly nine-tenths of its requirements in coal-tar dyestuffs (about 15,000 tons valued at £2,000,000 annually) from abroad—mainly from Germany. It was therefore clear that the outbreak of war had, unless the deficiency could be made up the British trade in coloured textiles would be severely handicapped as soon as the stocks in hand were exhausted. As early as Sept. 1914 a strong committee of British chemical manufacturers, colour manufacturers and colour users, styled "The Dyewares Supply Enquiry Committee," was inaugurated in Manchester under the auspices of the Society of Dyers and Colourists to discuss ways and means to meet the situation. This committee held numerous meetings at which various recommendations were made, some of which were ultimately taken up by the Board of Trade. The cardinal point which it was sought to elucidate from the start was the wants of the colour users, and to this end it was sought to make a classification of the imports before suggesting any definite course of action. The users were therefore appealed to, but although the majority readily responded several large users, including two of the large combines, refused to cooperate and the whole scheme fell through. The list, which would have been of great use and would not have taken long to compile, was completed and published at the instance of the Board of Trade five years later. In the meantime, stocks had long since become exhausted, and in spite of the enormous increased activity of the English colour makers and of the timely assistance of the Swiss colour works,<sup>2</sup> the supply was nothing like equal to the demand. The enormous profits realized by makers were largely devoted to extending and improving their works, but the prices of dyestuffs—both artificial and natural—nevertheless soared to unheard-of figures. The shortage of dyestuffs was brought home to the public by the miserable quality of the colours in wearing apparel offered for sale. Khaki for the army was dyed on wool mainly with a colouring matter of the meta-chrome series, whereas for cotton the old method (in which chromium and iron salts supply the colour without the use of any dyestuff) was available, but khaki shades were also dyed largely with sulphidic colours. Indigo for heavy clothing was not available in sufficient amount to go round, and its place was taken on wool by an azo dye known as codman's blue. For indigo-blue shades on cotton sulphidic blues were mainly employed.

The principal makers of coal-tar colours in England in 1914 included the following firms: Ivan Lestinnin & Co., Blackley; Manchester Road, Huddersfield; Claus & Co., Broyden; The Clayton Aniline Co., Manchester (owned by a Swiss firm and mainly concerned with intermediates); The British Alizarine Co. of Silvertown; a works at Bromborough owned by a combine of Swiss-German colour works, and a works at Ellesmere Port owned by another German combine. The two latter were sequestered by the Board of Trade and subsequently disposed of

<sup>2</sup> Seeing that the Swiss colour makers were likely to help the British textile industry out of their dilemma, the German Government stopped supplies of raw materials to Switzerland, and these were sent from England on the understanding that an equivalent supply of dyestuffs should be delivered.

to British manufacturers. In 1915 a company was formed with Government assistance to take over and extend the works of Read Holiday & Co. of Huddersfield under the style of British Dyes, Ltd. The amount of capital was £3,000,000, half of which was taken up by the Government and the other half largely by dye users, and it was decided at the time that the principal new works of the company should be established at Huddersfield, where a large tract of land for the buildings and yards had been purchased. Although at the time no efforts were spared to accelerate building and equipment the demand for colours still largely exceeded supply. Encouraged by the huge profits which were being made other works soon came into existence in various parts of the country, and each of these supplied its quota for users and for export. It may be said that in 1921 the development of the industry in England had proceeded so far that makers were in a position to supply a fair proportion of the colouring matters which were formerly imported—at a price. Considering the difficulties with which the makers had to contend in the way of having first of all to put up plant for the manufacture of the necessary intermediate products and then for the colouring matters themselves, in face of all the engineering and building restrictions which were accentuated by war conditions, great credit is due to the organizers and workers alike for this great achievement. Many processes were of course known to the chemists in pre-war works, and these offered little difficulty in the larger output. The intermediate products required for the manufacture of the azo dyes alone (the largest and most important class of the coal-tar colours) had to be first worked out in the laboratory before being put into operation on the large scale, for they had previously all (with the exception of aniline and toluidine) been obtained from Germany. In 1897 a plant was working in Manchester for the manufacture of two of the most important of these intermediates—beta-naphthol and alpha-naphthylamine, and German colour makers at that time actually drew their supplies of the latter product from England. But it was not many years before they were offering their own products for sale in England at prices lower than they could be produced at, with the result that the British manufacture was given up and imports were made from abroad. What was necessary in the way of preliminary work in the case of intermediates was naturally also required for the new colouring matters introduced, and this of course also required not only time but the undivided attention of a large number of skilled chemists. Another difficulty which the British colour makers were up against was the shortage of acids, especially oil of vitriol and fuming sulphuric acid or "oleum." This meant the huge additional burden of having to erect new chambers and contact plant without which progress would have ceased.

After 1918, the British Government, recognising the importance of dye manufacture as a "key" industry to the most important of the manufacturing industries—the textile industry, and in view of the fact that the colour industry and the manufacture of high explosives had something in common, decided to extend their support of dye-making as a national industry, and a new concern was launched under the style of "The British Dyestuffs Corporation, Ltd." The new firm included British Dyes and Levinstein, Ltd. (which had previously bought up Claus & Co.), and started off with a capital of £1,000,000. Lord Meston, who during the whole period of the war had undertaken the arduous and difficult duty of supervising the explosives branch of the Ministry of Munitions, was selected the first chairman of the new company. He possessed an intimate knowledge of some branches of the colour industry, and had from the outset taken a keen interest in their war-time development. The vast new works which have been erected by the company at Huddersfield are well planned and substantially built. Once in proper working order they should go far towards meeting the whole of the requirements of the British textile industries.

After the signing of peace at Versailles it was not unusual that the German colour makers should have desired to re-open their trade in coal-tar colours with England, and as the British

consumers had been so long accustomed to the excellent products which they had supplied, German colours again began to be imported. The legality of this procedure was challenged by the British Government, who caused a consignment of pyrogallol acid to be impounded under a Proclamation dated June 25 1919. But in the test case against Mr. John Brown, trading as Brown & Fourth, Mr. Justice Sankey held that the Proclamation was illegal and invalid. Subsequently some thousands of tons of German-made dyestuffs were imported, and it soon became clear that the regenerated British industry would receive a severe check through foreign competition. To obviate this the Dyestuffs bill, which it had been intended to bring in immediately following the Sankey judgment, was prepared and passed somewhat hurriedly (but not without opposition) through both Houses of Parliament and came into force on Jan. 15 1921. The Act offers protection to the colour-manufacturing industry for a period of ten years, and is worked out on the basis that no dyestuff may be imported which can be satisfactorily made in Great Britain. All imports in dyestuffs must pass through the hands of a licensing committee appointed by the Board of Trade. It was difficult to conjecture how this arrangement would work in the long run, but unless the prices of the British-made products were to be very materially reduced from their existing standard they were likely to constitute a drain on the textile industries which would not be justified. As long as the Act remains in force internal competition could operate as the only check. The colour users in England were quite prepared to pay a reasonable price for the possession of a colour industry of their own, and are large shareholders in the Dyestuffs Corporation. In this respect there is a precedent which, though well known in some circles, is not very common knowledge. About the year 1879 the manufacture of alizarine was almost entirely in the hands of the German works. They formed a combine and demanded an extortionate price for their products, whereupon the United Turkey-red Co. and other large British users of alizarine founded in 1882 the British Alizarine Co., which in spite of all foreign competition was a flourishing concern from its inception and has remained so ever since. Had it not been for the existence of these works (the only alizarine works in the world outside Germany) the English calico-printing trade would have almost gone out of existence during the war.

The difficulties which the British textile industry had to face owing to the shortage of dyestuffs was the lot of all other countries with a textile industry which were at war with Germany. In Belgium and France the industry was located almost entirely in the war zone. Nevertheless the French were not slow to rehabilitate their old-established colour-making industry. Italy never had one and was supplied for war purposes either with dyed material or with dyestuffs largely from England. In Russia a works was started previous to the revolution under the management of Swiss technical chemists with a capital of £1,000,000. Japan appears to have had a fairly large stock of German dyes, but before these gave out colour works were started in that country which are reported to have been worked successfully. In India the position was very bad, and recourse was had largely to the indigenous natural dyestuffs, which were, after all, not very long since, the only dyes used there. The position in the United States and in Canada was very much the same as in England. The United States had, however, the advantage of having come into the war much later, although in 1917 their stocks of foreign-made dyes must have been at a very low ebb. Several American colour works of considerable capacity had existed prior to 1914 and had been protected by a 30% ad valorem import duty, plus a fixed duty of 7 cents per pound on foreign dyestuffs. Without having to appeal to the State for further assistance, new and important works were started under the supervision of Swiss or German scientifically and technically trained chemists, private capital being abundantly supplied for the purpose.

It has been computed that, taking the world's production of artificial dyestuffs as 100, the distribution in 1923 was as follows: Germany 74.1, Switzerland 7, Great Britain 6.5, France 5.6

United States of America, 1913, Report 22: In view of the great changes which have taken place these figures are now of course no longer valid. What the figures were in 1921 was not even approximately known, but it is certain that the world's producing capacity, as distinct from actual production, was far in excess of any likely demand.

A good deal has been said and written about the correlation of dyestuff manufacture and the manufacture of high explosives, poison gases and other products required for chemical warfare. As far as the manufacture of high explosives is concerned, two main products, namely picric acid and trinitro toluole (T.N.T.), come into consideration. It is not very generally known that the former was made in England in large quantities as a dyestuff long before the French introduced it as an explosive. As a dyestuff it has long since been discarded, having been replaced by other coal-tar yellows of greater fastness which are not subject to any official restrictions. Both of these substances are nitro compounds of the aromatic series, and, like those manufactured as intermediates for dye-making, require, besides the coal tar common to both, large quantities of sulphuric acid, oleum and nitric acid (all products of the so-called "heavy chemical" industry) as raw materials. The nitrating operations are similar in both cases and similar plant is used, but there is always a limit to the size of the nitrating vessels which it is neither safe nor economical to exceed. Once the process is standardized on a unit of plant any increased production is obtained by increasing the number of units. Naturally any plant producing such nitro compounds in a colour works could in an emergency be turned to account to produce such a substance as T.N.T., but the amounts required for any serious military or naval operations would be vastly in excess of what could be turned out with the nitrating plants of even large colour works. Nitrating is only one of a large number of important operations required in colour manufacture, and some dyestuffs are manufactured entirely without the help of this operation. The idea which seems to have become prevalent that the plant in a colour works is capable of turning out anything from a finished dyestuff to mustard gas or any new product that may come along is untenable. What is really wanted in this respect is a body of alert, scientifically and technically trained chemists. The best guarantee for the requirements of "chemical warfare" in the future is the possession of a successful colour industry, for the chemist best suited by training and habit of mind to cope with an emergency problem is the colour chemist.

REFERENCES.—J. K. Wood, *The Chemistry of Dyeing* (1913); I. Merritt Matthews, *Application of Dyestuffs*; C. M. Whittaker, *The Application of the Coal-Tar Dyestuffs* (1919); A. C. Green, *Analysis of Dyes and Dyed Materials* (1911); for qualitative and for quantitative work, *New Reduction Methods in Volumetric Analysis*, Knoch and Hibbert. (E. K.)

United States.—The dyeing industry of the United States during 1910-21 grew commensurately with the textile industries. An important advance was made in the production of fast colours on cotton goods. This was in keeping with the rapidly extended use of cotton in high-grade wearing apparel and the increase of steam laundries, displacing household washing. Modern laundry methods of rapidly cleansing and whitening fabrics necessitated the use of strong chemicals, destructive of the colours formerly employed in dyeing cotton. The demand for laundry-fast colours was met by the introduction of the so-called "vat" dyes of which indigo was long the only representative. The extended use of the dye known as sulphur black to take the place of aniline black for cotton hosiery and piece-goods was also worthy of note. The silk industry in America also grew largely, consuming more raw silk in manufactures than any other country. This led to the great extension of silk-dyeing, chiefly in the industrial centres of South Manchester, Conn.; Paterson, N. J., and Lancaster, Pa.

The World War at first threw the dyeing industry in the United States into confusion, owing to the uncertainty of trade relations with Germany, the more so when the Allied blockade put a complete embargo on Germany's exports. It was then seen how dependent America had been on Germany for dye-

stuffs, and it was estimated that manufacturing industries with products valued at about \$5,000,000,000 might soon be thrown completely out of gear by a lack of dyestuffs. In the confusion which resulted all manner of expedients were adopted in the production of colours with a consequent reduction in the fastness and quality of dyeing. Dyestuffs became so scarce that exorbitant prices stimulated the erection of many dyestuff factories in various parts of the United States. Large amounts of capital were freely invested in the new industry, and many chemists became engaged in dyestuff research and manufacturing.

Previous to the war the United States had a small dyestuff industry distributed among about five plants. The manufacturing operations, however, were limited chiefly to the assembling of the coal-tar intermediates imported from Germany for the production of the finished dyes, so that the new industry had to be built from the ground up. To the great credit of the American chemist and chemical manufacturer it may be said that in a very short time the more important dyes were successfully made in the United States in such quantity that practically no dye-consuming industry was forced to shut down by reason of a lack of dyes. Indigo and sulphur black were soon produced on a large scale, as well as the required acid dyes for wool and silk, most of the basic dyes, and a complete line of the direct cotton dyes. In 1920 there were 213 firms manufacturing dyestuffs and related coal-tar chemicals. These employed about 2,600 chemists and nearly 20,000 workmen and the total value of the finished products amounted to over \$112,000,000. There were 236 different intermediates manufactured and 360 different dyes. The total production of dyes amounted to over 88,000,000 lb. as against a pre-war importation of about 70,000,000 pounds. The total value of the finished dyes was given as \$95,600,000, so that the average price per pound was about \$1.07. Over 18,000,000 lb. of synthetic indigo was made, about twice the pre-war importation, indicating great extension in the use of indigo. Associated with the making of dyestuffs there also grew up the many related branches of the coal-tar chemical industry, such as colour lakes for paints, lithographic and printing inks; coal-tar pharmaceuticals; flavouring and perfume materials; photographic chemicals and synthetic tanning and resins. The great growth of the industry created a constant demand for increasing quantities of coal-tar distillates, which form the raw materials of the dyestuff industry, and this led to a rapid increase in the number of by-products coke ovens. In 1920 the production of coke in by-product ovens amounted to about 60% of the total.

The great production of dyes in the United States during the period 1927-21 led to the building up of a considerable export trade, particularly to South America and the Orient. The total dyestuffs exported from the United States in 1920 amounted in value to nearly \$30,000,000, of which \$22,500,000 was for coal-tar dyes. This export trade, however, showed a rapid falling off from the beginning of 1921; due both to the general business depression throughout the world and to the fact that the German dyestuff manufacturers were again active in foreign trade.

At the close of the war the American dyestuff manufacturers quickly realized that unless they had suitable Government protection they could not meet aggressive competition from European dyestuff factories. In 1916 they petitioned for, and obtained the passage of, a bill placing a tariff of 30% ad valorem and a specific duty of 5 cents per pound on most dyes. When hostilities ended certain Government regulations were also applied to the importation of dyestuffs and related products from Germany so that such importations were licensed to bona fide consumers and were limited to dyes that could not be satisfactorily obtained from the American manufacturers. In the meantime Congress was petitioned for an embargo on importation of dyes from foreign sources except under adequate licence regulations which would restrict the imports to dyes not manufactured in the United States. This was in line with similar action by Great Britain, France, Italy and Japan, all these countries deeming it highly expedient to foster and build up a self-contained dyestuff and coal-tar chemical industry as a measure of national defence.

In the matter of natural dyestuffs America has always occupied a leading position. Many of the principal natural dyes are of American origin. Logwood, fustic, cochineal and the red-woods are all American products, discovered in, and still obtained from, Mexico, Central America and South America, as well as the West Indies. During the war a product very closely resembling fustic and known as osage orange was also developed in the United States and in 1921 was being produced in considerable quantities. As the dyer usually employs the colouring matters of the dyewoods in the form of suitable extracts, there has long been developed in the United States a considerable industry in the manufacture of these extracts, generally produced in connexion with the manufacture of tannin extracts. This industry is in no way associated with the coal-tar dyestuff business. The great scarcity of dyes during the early part of the war resulted in an abnormal expansion of the dyewood extract industry, which rapidly declined as the manufacture of synthetic or coal-tar dyes increased. In former years natural indigo was extensively used in dyeing, and in early colonial days large quantities of this dye were cultivated in the south. As the growing of cotton increased, that of indigo was neglected, so that most of the indigo used in the United States was imported, chiefly from the Far East. A certain amount, however, had long been obtained from Central American provinces and the West Indies. The advent of synthetic indigo soon displaced the natural product, so that little of this vegetable dye was used in America, although the United States in 1921 manufactured all it needed of this most important dye. After the war, owing to the shifting of the centres of trade, the United States became an important market for the sale and manufacture of furs. This resulted in the building up of an extensive industry in the dyeing and finishing of furs which will without doubt become firmly established as an important adjunct to the general dyeing industry of America.

(J. M. M.)

**DYSENTERY** (see 8.785\*)—This term is now employed to designate a clinical syndrome characterized by the passage of blood and mucus consequent upon the pathogenic activities—primarily upon the large bowel, leading to ulceration—of certain animal or vegetable forms of life. The advances in our knowledge of dysentery made during 1918-20 were considerable, and were in great measure due to the combined interdependent efforts of protozoologists, bacteriologists and entomologists in their unremitting investigations and laboratory researches, to their fruitful collaboration with the physician, also to the extensive experience gleaned through the World War. Dysentery as a disease is widespread throughout the world and workers in all continents and many countries have shared in the progress of knowledge of it. This was, moreover, essential as certain causal organisms amongst the helminths can only complete their life-cycle in the particular regions where their primary host, a lower animal, exists in nature.

Again, climatic factors play a rôle in the incidence of certain types of dysentery; and the organisms, their rôle and specific lines of treatment and prevention, can be best studied where the disease prevails. Thus American workers in Manila firmly established by experiments on condemned prisoners that there is but one, *Entamoeba histolytica*, of the five amoebae found in man which is pathogenic to him, and finally cleared up the confusion by determining its life-cycle and differentiating it from the *E. coli*, an amoeba living also in the large bowel of man.

From Hong-Kong we learned the specific action of emetine, an alkaloid extracted from *Ipheocyantha*, on amoebae; and its application with such beneficial results to man was first made in India. Though amoebic dysentery was until recently considered a disease of the tropics, and rare in temperate countries, relative researches on inhabitants of several temperate countries show a small percentage to harbour the *E. histolytica*; some without complaint of dysenteric symptoms. The conditions of climate, sanitation, food and living may favour individual resistance as well as susceptibility to acute symptoms. Recently a few workers in England have concluded that there are two or more strains of the *E. histolytica*, distinguishable by the size of the cyst each

forma. French physicians in Indo-China have observed that in one region the *E. histolytica* gives rise to more severe dysentery and is less amenable to treatment than in another, thus raising the question of a difference in virulence amongst strains.

In Rumania in 1906 a new and distinct species of *Bacillus dysenteriae*—*Bacillus dys. Schmitz*—was first found.

In England and France the presence of bacteriophage has been determined. If a few drops of the filtrate from a culture of the dysenteric bacillus Shiga be placed in a new growth of the bacillus; the micro-organisms are dissolved. The action is considered due to the development of an ultra-microscopic micro-organism which destroys the bacillus and appears to be specific.

As dysentery may be due to diverse organisms, the causal one or its family or generic name is employed to specify the origin, thus—amoebic, bacillary, spirochaetic, ciliar and helminthic dysentery. When there are evacuations of blood and mucus associated with inflammation and ulceration, not due to an organism which acts primarily and specifically on the lower bowel, but which may primarily attack another part of the body (i. tubercle, syphilis), or to carcinoma, or due to an impacted foreign body or mechanical irritation, the condition is termed, to distinguish it, pseudo-dysentery. When an ulcer is low down it can be seen and its character determined by the sigmoidoscope.

It is important to determine the causal organism in a sporadic dysentery case or in an epidemic; not only because of the specific treatment necessary but to assure adequate prevention of its extension; and laboratory collaboration for this is essential.

It has been amply exemplified that dysentery cannot be imposed on the presence of blood and mucus in the stools with accompanying abdominal pain and tenesmus. One or more of these symptoms may be absent, for they depend on the extent of the ulceration. In the contact or healthy carrier of the *E. histolytica* there may be no signs past or present, the *E. histolytica* to all appearances living as a harmless commensural within a human host, and the first sign of the presence of the disease may be a liver abscess, a very rare condition outside tropical regions. It is only by investigating these contact carriers in the laboratory that the disease can be detected from cysts in the faeces.

Dysentery has always been the most dire disease accompanying war. During the World War, despite our greater knowledge of its causes and of prophylactic measures to counteract it, its invaliding rôle was considerable in all armies, especially those fighting in tropical countries where the conditions favour it, and in parts of eastern Europe where sanitary control was not scrupulously exercised. The number of admissions to military hospitals which follow testify to its ravages amongst British troops, and many others there were who did not seek hospital treatment. The comparatively small death-roll was no doubt due to the application of the advances in our knowledge that dysentery may be due to diverse organisms, each having a specific line of treatment to be directed against it. Most deaths were due to *Bacillus dys. Shiga*.

In France there were 11 cases in 1914; 1915, 26 cases; 1916, 5754; 1917, 6931; 1918, 12,211 cases—figures which are relatively small considering the number of troops there. In East Africa 1917, 9,369 cases, 317 deaths; 1918, 1,636 with 38 deaths. In Mesopotamia 1916 (6 months), 1,935 cases with 126 deaths; 1917, 4,860 with 153 deaths; 1918, 8,450 with 102 deaths. In Egypt 1906, 5,577 cases with 81 deaths. In Italy 1918, Forward Area, 897 cases with 17 deaths; Lines of Communication (Toronto), 146 cases. In Salonika 1916, 5,987 cases with 132 deaths; 1917, 5,842 with 124 deaths; 1918, 9,398 with 158 deaths. On the Gallipoli Peninsula figures were not obtainable, but it is estimated that nearly every soldier who landed on the peninsula suffered from dysentery or diarrhoea and few escaped the former disease. Severe climate, difficulties of obtaining adequate food and sterilized water, fly pests, fatigue, hastily improvised resting places and sanitary arrangements, prolonged periods in trenches—all were important factors conducive to susceptibility in man and to the spread of infection.

Bacillary and amoebic dysenteries greatly predominated. There were exceptional and sporadic cases of spirochaetic and, amongst coloured troops especially, of ciliar and helminthic dysentery. In all countries bacillary greatly predominated. In France other than bacillary infections were rare and the amoebic type was found more frequently amongst those associated with troops from tropical countries or who took over camps or trenches used by them. In tropical and sub-tropical regions the percentage of amoebic is

\* These figures indicate the volume and page number of the previous article.

other dysentery cases was approximately 20. More particularly in California combined infections were not uncommon and there were cases suffering from dysentery and enterica at the same time.

During 1920, of 1,6193 returned troops claiming State aid for disability from war dysentery, 446 were still harbouring the *E. histolytica* and over 80% of these were intermittently or constantly passing blood or mucus; two acquired a liver abscess when in England as a complication; eight were still infected with the *B. dys. Shiga* and four with *B. dys. Flexner-Hiss*; one case had mixed amoebic and bacillary (Shiga) infection, and three mixed amoebic and spirchoetic, and six spirchoetic dysentery.

By reason of the variety of the causal organisms, the clinical symptoms and pathological characters to which each gives rise and the specific treatment directed against it, each type of dysentery had best be considered separately, and the commoner types, amoebic and bacillary, discussed in greater detail.

**Amoebic Dysentery** (also called Amoebiasis, Loeschiasis or Tropical Dysentery, after the cause of its early endemicity and greater incidence there).—The causal organism, *E. histolytica* (Loesch 1871), a species of the genus *Entamoeba*, affects man alone in nature, though the dog and cat and recently the guinea-pig have been infected experimentally. The *E. histolytica* in its life-cycle in man passes through three stages—a large vegetative stage when living within the tissues, giving rise to ulceration and passage of blood and mucus; a pre-cystic or *minuta* stage found in convalescents and in carriers when the amoebae are much smaller, live on the mucous membrane within the bowel, but which may pass through the membrane and assume the larger vegetative form, with ulceration and its symptoms following; and a cystic stage. The amoebae increase in numbers by division of the parent into two, but it is only the pre-cystic or *minuta* stage in which many of the amoebae contract into a smaller rounded or ovoid form, develop a firm outer wall and are transformed into cysts with the characteristic one to four nuclei and containing chromatoid rods which possibly act as food stores. Since it is only by swallowing these cysts that man is infected, the continuance of the entamoebiasis in nature is thus provided for. These cysts do not resist drying, but retain their vitality for two weeks if kept moist in the faeces or in water. They can therefore be transmitted by direct contamination with faeces through handling soiled linen, by flies carrying them on to food, by soil or by drinking contaminated water; and prophylaxis must be directed accordingly.

Clinically the disease is characterized, as are all protozoal infections, by its chronicity with tendency to recrudescence of symptoms. The onset is insidious, the sufferer first noticing a feeling of debility and lassitude with an increase of stools, soft in character, for several days. These may clear up and be the only signs noticed or may light up again and assume true dysenteric characters months later. Most often the initial stage is followed on by an acute exacerbation of symptoms, dependent in their degree upon the extent of the ulceration in the large bowel, the most markedly affected sites being the caecum and sigmoid. Stools become still more frequent, up to 40 or 50 in 24 hours, and the ulceration gives rise to abdominal pain and, if at the rectum, to severe tenesmus. The patient takes to his bed exhausted. In uncomplicated cases there is but slight rise of temperature or other symptoms of toxæmia as the entamoeba produces no toxin. The entamoeba gains entrance to the body by the swallowing of its cysts, which pass through the stomach unchanged. In the small intestines they germinate and young amoebulae are set free in the lumen of the intestine. They increase in size, multiply by a process of division, and by means of their lytic or dissolving power penetrate through the mucous membrane lining the large bowel, rarely the appendix save at its base, into the sub-mucous layer, where they continue to proliferate, destroy the tissue, including the blood-vessels, thus leading to the hæmorrhage that accompanies the mucus produced by the irritation of the membrane, and impede the circulation of blood and lymph at the site. A typical flask-shaped ulcer is formed, with roughened undermined edges at the orifice. When ulcers are situated approximately they are frequently joined by submucous tunnels, and the ulcers being mechanically produced, there is little accompanying inflammatory reaction. Occasionally super-added infection with other bowel organisms supervenes and gangrene may follow, or the amoebae may penetrate through the outer muscular walls of the large bowel, giving rise to perforation and accompanying peritonitis, or, by penetrating a blood-vessel, they may be carried off in the blood stream and give rise to an abscess in the liver, to which the blood first takes them, or, as most exceptionally happens, an abscess in the brain or elsewhere. Healing is brought about by the development of fibrous tissue at the sites of the ulcers, and this contracts and leads to a thickening of the walls and constriction of the lumen which, if extensive, produces subsequent chronic constipation; or, what is rare, to stenosis and blockage. Diagnosis is quickly made by examination of the stools. In the acute condition they may consist entirely of blood and mucus or contain also a little faecal matter. The mucus is stained a brownish colour by degenerated blood cells and the blood is usually in the form of clots, not evenly mixed through it. Microscopically the *E. histolytica* is readily found and is distinguished by its rapid movement, ill-defined nucleus and greenish-

tinged ectoplasm, and ingested red cells. White blood cells apart from a relative increase of eosinophils are not seen in great numbers. Charcot-leyden crystals, as yet only seen in dysentery of the amoebic type, may be found.

The acute symptoms readily subside under appropriate treatment. The patient should be put to bed. The specific treatment is ipecacuanha or an alkaloid extracted from it, emetine. Combined hypodermic injections of emetine hydrochloride with oral administration of ipecacuanha (Brazilian), to attack the amoebae from within and without, have given striking results in allaying symptoms. More recently emetine alone or in combination as bismut-emetine-iodine in a salol capsuled pill has been widely employed and good results are claimed, especially in the treatment of chronic cases. The toxic action of emetine on the heart must be watched. Added to the specific treatment in acute cases there is the general and symptomatic, which should include a free flushing of the bowel by a dose of castor oil with tinct. opii. added; later followed by magnesium (or sodium) sulphate in hourly or two-hourly half or drachm doses for 12 or 24 hours. Morphia may be necessary to relieve the abdominal pain and straining. The diet must be light and easily assimilated. Milk and raw foods should be withheld.

The symptoms subside in one to three weeks and no further trouble may supervene. However, the patient not infrequently is left with symptoms, generally slight, from cicatrization of the bowel, or, from persistence of the entamoeba, becomes a convalescent carrier as distinguished from a contact carrier, one who has never developed acute symptoms. The treatment of these carriers is one of considerable importance not only for the individual, who may redevelop acute symptoms or a liver abscess, but for the community, since these carriers pass in their stools the cysts of the entamoeba which can infect others. Treatment apart from symptomatic is directed to eliminate the amoeba in chronic cases and consists in giving orally ipecacuanha or emetine alone or combined with other drugs as a pill, capsule or paste in courses over a number of days. Emetine hydrochloride subcutaneously, or neosalvarsan intravenously, have been employed to supplement oral treatment. At the same time the large bowel is washed out by enemata per rectum, the use of an antioestomy wounds not having given sufficiently encouraging results, with solutions of quinine, tannin or, as recommended by the French, of neosalvarsan. Indiscrctions in diet should at all times be avoided and it appears advisable for the carrier to reside in a temperate region. Amoebic hepatitis and a small abscess of the liver are cured by injections of emetine hydrochloride or neosalvarsan, but a large abscess needs surgical intervention.

**Bacillary Dysentery.**—While sharing with the amoebic the clinical dysenteric syndrome above described, it differs therefrom in the shortness of the inoculation period, generally 24 to 72 hours; in its sudden acute onset with elevation of temperature, which may persist several days or more; and other symptoms of toxæmia; extreme contagiousness; seasonal incidence (midsummer and autumn); epidemic character and predilection for temperate regions; higher death-rate and in the complications that may follow infection with *Bacillus dys. Shiga*, namely—arthritis, conjunctivitis, muscular paralysis and myocarditis. Clinically it may assume forms varying in symptomatology from mild to severe, and occasionally is hypertoxic, typhical or micro-gangrenous in character. Outbreaks of dysentery in asylums, prisons, concentration camps and ships are generally bacillary in type. In tropical regions the amoebic type also occurs, but in temperate regions this latter form is practically limited to sporadic cases.

The bacillary dysentery group comprises species of bacilli generally related. 1. *B. dys. Shiga* (Chantness and Widal 1888, Shiga 1898, Kruse 1900), a well-defined homogeneous species, known as the true dysentery bacillus since it alone contains endotoxins which are pathogenic to man and experimental animals. 2. *B. dys. Schmitz* (Schmitz 1916, Andrewes 1918, Broughton-Alcock 1918), another homologous species and one which contains endotoxins acting severely on rabbits but less pathogenic to man. 3. *B. dys. Flexner-Hiss*, a very mildly toxic group of bacilli characterized by their power to ferment mannite, produce indol from peptone and containing many species as recently distinguished by the agglutination and absorption reactions. 4. A further group which embraces bacilli characterized by specific agglutination and absorption properties and power to ferment certain sugars, e.g. *Bacillus of Strong, Castellani, Gay, d'Herville* and others, each capable of producing a mild clinically dysenteric syndrome in man.

Clinical symptoms vary, as does the degree of the intestinal lesions and the toxicity of the causal bacillus. Infections with *B. dys. Shiga* are characteristically the most severe. The ulcerative lesions are not confined to the large bowel but extend one to two feet into the small intestine. Recent researches have proved that the bacilli pass through the stomach, multiply in the small intestine and produce at least two toxins which are absorbed into the blood, one acting on the nervous system and the other excreted into the large bowel, causing inflammation with coagulation of lymph, thrombosis of vessels and necrosis of the submucous layer and superimposed mucous membrane. An exudative fibrinous diphtheritic-like membrane forms on the bowel wall and separates off, leaving superficial ulcers with raised red oedematous edges. These may



deepen by continued microbe action and even penetrate through into the peritoneum; leading to peritonitis, or gangrene may set in in the damaged necrosed tissue, and in either case death follows unless surgical intervention is early. Repair proceeds along the same lines as in amoebic cases, but, the ulcers being generally more superficial, the permanent damage is not so great.

The stools have a characteristic microscopic appearance, as numerous pus epithelial cells and large macrophage cells are present in the mucus. Macroscopically the stool most often consists of mucus, like cloudy-grey streaked or stained by bright red blood, or the mucus may be bile-stained in a diarrhoea-like stool or, in very severe cases, there are shreds of necrosed mucosa.

The causal bacillus is readily isolated by culture within the first days, but afterwards it becomes difficult as the microbe life in the necrotic tissue becomes a flora of proliferating organisms. The bacillus of Shiga, which has been the only species isolated from the blood stream, has been found therein in only four or five cases. The bacilli dysenteriae, as judged by post-mortem findings, pass to the mesenteric glands along the lymphatics, but are arrested there. After the cessation of the symptoms the percentage of cases retaining the causal organism in the bowel is very small, as testified in the figures given above. If the patient becomes a carrier of *B. dys. Shiga* the stools will continue to be in part mucus-purulent, even up to three or more years. The property of agglutinating the causal organism and other strains of the same race is present in the blood after the first week and may last for only eight or ten days in mild cases, but when the infection is prolonged this property of agglutination persists for a longer period. *B. dys. Shiga* infected cases generally agglutinate also the *B. dys. Flexner-Hiss* in a lesser degree, but the converse does not hold. *B. dys. Flexner-Hiss* cases agglutinate several species of the group, rarely only the strain isolated from them. *B. dys. Schmitz* cases do not appear to develop agglutinins even for their own organism.

The general and symptomatic treatment given above for amoebic dysentery is similar, but the specific treatment widely variant, and is directed towards neutralizing the toxins which further the clinical symptoms. It is the anti-Shiga serum, prepared by inoculating the bacilli with their contained endotoxins into the horse, which is the most efficacious; and as it is the infection with *B. dys. Shiga* which is most severe, its utility is considerable. It has been employed also in cases due to *B. dys. Flexner-Hiss* with apparently satisfactory results. A polyvalent horse anti-serum made by inoculating strains of both these groups has also been extensively given in cases of either infection, and, with this, amelioration of symptoms has followed. The injection of anti-serum should be as early in the illness as possible, and in large doses dependent upon the severity of the cases, e.g. 60 c.c., 40 c.c., 20 c.c., on successive days in a severe case; and with this treatment free saline purgation is combined until the stools become faecal. Thereby rapid amelioration follows, complications are rare, and the bacillus quickly eliminated from the body. In the early complications of bacillary dysentery anti-serum therapy again gives good results.

The general prophylactic measures to be taken are comparable to those against infections with *E. histolytica*, but it should be remembered that bacilli are lower vegetable organisms and can

proliferate in suitable environments outside the body. Dependent on several factors, bacillary is more contagious than amoebic dysentery. Encouraged by successful results following inoculations of typhoid and paratyphoid vaccines, some series of inoculations with a vaccine of *B. dys. Shiga* were made in epidemic areas during the war, as this was the bacillary organism so prevalent and so toxic in epidemics during war conditions. Its contained toxins give rise to acute local reactions unless modified prior to inoculation by special methods, as by leaving the heat-killed bacilli with normal serum (serum-treated) or with specific horse anti-serum (sensitized), or by inoculating both specific anti-serum and bacillary emulsions on approximating days, or by giving an absorbed specific anti-serum and bacillary emulsion simultaneously, or by emulsifying the bacilli in oil. The series of inoculations made by various workers gave encouraging results. Vaccine therapy employed to rid the convalescent carrier of *B. dys. Shiga* has not been successful. In striking contrast with *B. dys. Shiga* the killed and untreated emulsions of the *B. dys. Flexner-Hiss* group give rise to no reaction, even in high doses.

**Spirochaetic Dysentery.**—due to *Spirochaeta eurypyle* (Le Dancé 1900, Werner 1910, Fanham 1916).—Investigation of this type of dysentery is in continued progress, and evidence is increasing that this spirochaeta is capable of living upon the mucous membrane of the large bowel and maintaining a chronic form of dysentery. It is seen in considerable numbers in the mucus and occasionally also within the lining cells of the glands. Occasionally there is also blood present with the mucus which is being continually passed with faeces. An acute condition with passage of blood and mucus only has been observed. This spirochaeta is resistant to intravenous injections of neosalvarsan or tartar emetic alone; and treatment by an arsenic-containing compound at the same time as a local washing of the bowel with irrigations containing eucalyptus has given the most encouraging results.

**Helminthic Dysentery.**—The chief helminths which give rise to dysentery are the bilharzia worms, *Schistosoma mansoni*, in Africa, South America, West Indies, and *Schistosoma japonicum* in the Far East. Bilharzia dysentery is characterized by the passage of mucus and clots of blood due to the presence of the ova which the adult female worm lays in the capillaries of the wall of the rectum. This form of dysentery is extremely common in Egypt. The discovery of the intermediate snail host and the specific action of sodium or potassium tartrate in killing these worms in man is an advance of considerable value.

Other trematodes which may cause dysenteric symptoms are *Fasciolopsis buski*, *Heterophyes heterophyes* and *Paragonimus westmanni*. Normally the last is a lung fluke, but it occasionally occurs in cysts of the intestinal wall, when it gives rise to the passage of blood and mucus in the stools.

In heavy infections with hook-worm (*Ancylostoma duodenale*) present in England in the mines of Cornwall, and *Necator americanus* blood and mucus are sometimes passed in large quantities, and the cases may be mistaken for true dysentery. Thymol given orally rapidly kills off these worms.

**Ciliar Dysentery.** due to *Balanitidium coli* and known to occur in Japan and the Philippine Is. is rare elsewhere and needs but mention. A specific remedy has not yet been found. (W. B. A.)

**EAKINS, THOMAS** (1844-1916), American painter (see 8.791), died at Philadelphia June 25 1916.  
**EAST, SIR ALFRED** (1849-1913), English painter (see 8.847), was knighted in 1910, and died in London Sept. 28 1913.

**EAST AFRICA: MILITARY OPERATIONS, 1914-8.**—The outbreak of war found all the combatants in East Africa unprepared for offensive operations. But the advantage inclined to the Germans, for they had forces on the spot sufficient for defence, which was not the case in respect to the British protectorates bordering German East Africa. The Belgian Congo was also without adequate means of defence.

Hostilities were entirely unexpected. So little was the Government of British East Africa anticipating war with its German neighbours that the bulk of the Protectorate Force, a battalion and a-half of the King's African Rifles—negro troops officered by Europeans, together with the Uganda battalion of the same force, was, in Aug. 1914, engaged against recalcitrant tribesmen in Jubaland, on the borders of Italian Somaliland, 500 m. away. In short, all the British protectorate lay open to invasion. But Lt.-Col. von Lettow-Vorbeck, commander of the forces in German East Africa—the one German soldier who earned a high reputation in the colonial campaign—knew that his opponents would be reinforced from overseas, and contemplated nothing more than an offensive-defensive. His total force, when the war began, was just under 5,000, including 260 Europeans.

The British had the advantage of the command of the sea, and the ports of German East Africa lay open to attack. So keenly did the governor of the protectorate, Dr. Heinrich Schnee, realize their helplessness that one of his first orders was to forbid any action to be taken which would lay the ports open to bombardment. As in the case of the governors of British Dominions and Colonies the governor of German East Africa was also commander-in-chief of the forces, and Dr. Schnee asserted his authority in that respect despite the protests by von Lettow. Indeed, Dr. Schnee and many of the Government officials at Dar-es-Salaam, the capital and chief port, had "little stomach for a fight," and when on Aug. 8 two old British cruisers, the "Astræa" and "Pegasus," steamed across from Zanzibar to Dar-es-Salaam, by the governor's orders and without the knowledge of von Lettow, negotiations for surrender of the port took place. The ships had no force to garrison the town, but the Germans signed an agreement "which forbade us to undertake any hostile act in Dar-es-Salaam, while the enemy was not so bound" (von Lettow). The same day Dr. Schnee left Dar-es-Salaam for Morogoro, a pleasant hill station with European amenities, 140 m. inland by train. The high-power wireless station at Dar-es-Salaam which communicated with Berlin was destroyed.

Despite the attitude of the governor, von Lettow determined to carry on the fight to the utmost possible limit. He had taken up his command in East Africa in Jan. 1914 convinced that "the universal war," as he calls it, might be imminent, and that if it broke out it was his duty to combat as many of the enemy as he could and for as long as he could.

The country was highly favourable to protracted defence by a resolute and ruthless commander, such as von Lettow proved.

A very large proportion of the country is covered by "bush," that is an undergrowth sometimes more or less open, but usually dense, from which rise trees to a height of some 30 feet. This bush covers hills and valleys and even dry desert, and in the coast region develops into luxuriant jungle. Much of it is infested by the tsetse fly. Some areas are covered with dense forests, others with elephant grass growing 6 to 10 or more feet high. The valleys of almost all the rivers are swampy and fever stricken; during the rains vast areas become inundated; in the dry season, away from the rivers, water is often lacking; wild animals constitute a real danger, especially to the wounded. The climate is tropical and very unhealthy save

on a few high plateaus, and in certain hill districts malaria is endemic. These conditions existed throughout German East Africa, a country nearly double the size of Germany. The "bush" was the greatest asset of the defence. As Gen. Smuts wrote (in 1918), "in the African bush, with its limited visibility, it is practically impossible to enclose an enemy determined to escape." The method is simple—when a force is so hard pushed that destruction is inevitable if resistance continues the order is given to "line for bush," whereupon the force splits up into parties of threes and fours and vanishes into the bush. Pursuit is hopeless, and the scattered enemy, if well trained, reassembles at an appointed rendezvous. Moreover, so dense is the bush over many thousands of square miles that considerable forces may be on the march within a mile of one another, without being aware of each other's existence. These factors explain why, given sufficient armament and food, von Lettow was still in the field when the Armistice was signed in Europe, in spite of his isolation and the superior forces that after 1916 were brought against him.

Von Lettow had drawn up his plan of campaign before hostilities began, and as the best means of defence had determined to take the offensive against the enemy's most sensitive spot. This he rightly conceived to be the line of the Uganda railway (which runs from Mombasa to Victoria Nyanza). The line is parallel to and about 50 m. distant from the (then) Anglo-German frontier. It passes through the Highlands, where the British European population is concentrated with Nairobi as chief town. On the "German" side of the frontier are the Usambara hills and the Pare mountains, presenting a wall-like face to British East Africa, with few passes. But between the northern end of the Pare mountains and the towering slopes by Kilimanjaro, which rise farther north, was a distinct "gap" forming the usual passage-way between the German and British protectorates. A railway from Tanga, the port of Usambara, ran to Moshi, on the slopes of Kilimanjaro, and at the western end of the "gap." At its eastern end, in British East Africa, is Taveta. This place was seized by the Germans on Aug. 15 and was used by them as a jumping-off ground for raids on the Uganda railway, raids which included the design of occupying Nairobi.

At the outset, or shortly afterwards, a design was also entertained by the Germans of capturing Mombasa and holding it long enough to wreck the harbours and destroy the great railway bridge from the island to the mainland. This was rendered possible by the return to Dar-es-Salaam in Sept. of the cruiser "Königsberg" (it had sailed from that port shortly before the declaration of war). It was then arranged that a force should march along the coast from Tanga on Mombasa, while the "Königsberg" attacked it from the sea. On Sept. 20 the "Königsberg" appeared off Zanzibar and destroyed the "Pegasus," which was in the roadstead undergoing repairs. Mombasa was to be attacked on Sept. 29. But the "Königsberg" did not keep its engagement, ships of the Cape Squadron under Vice-Adm. King Hall intervening. Harried by the British, but not overtaken, the commander of the "Königsberg," Capt. Looff, in Oct. ran his ship aground in the shallow waters of the Rufiji river, south of Dar-es-Salaam. The land force which was to cooperate with the "Königsberg" was already at Vanga, just within the British border, and it began its march of 50 m. along the coast on Sept. 20. It attacked Gazi, 25 m. from Mombasa, on Sept. 23, was repulsed and forced to retire to the frontier on Oct. 8.

Apart from raids along the coast and on the Uganda railway the Germans made a series of incursions into the frontier districts of Uganda, the Belgian Congo, Rhodesia and Nyasaland. For

Von Lettow records that at first many officers were loth to obey his orders, because, apart from the governor's attitude, they believed that "under the Congo Act" they were obliged to be neutral. In fact the German Government made neutrality proposals on Aug. 25 1914. These were rejected by the Allies (see *AFRICA: History*).

these minor operations the Germans had the advantage of a central position, interior lines and better means of communication. The railway from Dar-es-Salaam to Kigoma on Lake Tanganyika had been completed about six months before the war began, and during Aug. the small steamer "Hedwig von Wissmann," manned and armed by German sailors from Dar-es-Salaam, sank the only hostile boat on the lake, a small Belgian vessel. Thus the Germans had command of the 400 m. of waterway on Tanganyika. On the two other lakes, Nyasa and Victoria, the British, however, early obtained command.

The operations in all theatres other than on the British East Africa frontier were regarded by both sides as subsidiary. At first the British had to consider purely defensive measures. At the outset the East Africa Protectorate Force was under the command of Lt.-Col. L. E. S. Ward. Volunteers were called for, and two regiments, one mounted, were at once formed by the white settlers in British East Africa. The King's African Rifles were recalled from Jubaland and were in action by September. An Arab detachment was raised on the coast by Lt. (subsequently Maj.) A. J. B. Wavell (an adventurous soldier who had made the pilgrimage to Mecca), and it rendered good service until its gallant commander was killed in action Jan. 6 1916. But outside help was needed, and the Government of India consented to send a force, officially known as "Indian Expeditionary Force B." The first regiment, the 20th Punjabis, arrived at Mombasa at the end of Aug., and with them Brig.-Gen. J. M. Stewart, who took over the command.

Plans for an offensive were now formed. It was decided that the bulk of the force from India should land at Tanga and occupy the Usambara Highlands, the most healthy and most developed region of German East Africa, and in which lived the majority of the German settlers. The landing finished, it was intended to advance along the railway from Tanga to Moshi. At the time Tanga was attacked Gen. Stewart was to demonstrate against Taveta, and to sweep round by Longido (N. of Kilimanjaro) to Moshi. Brig.-Gen. A. E. Aitken was selected to command the Tanga expedition. India was then being heavily drained of troops for service in France, and for East Africa troops that were not all of first-class quality had to be employed. The strength of the force was about 7,000, including one British unit, the 2nd Batt. Loyal North Lancashire Regiment. The force sailed from Bombay towards the end of Oct. and the transports arrived off Tanga harbour early on Nov. 2. The attack had been expected, news of the expedition having reached the Germans through captured Indian mails, and at the end of Oct. von Lettow had arranged with the district commissioner, Auracher, that Tanga should be defended, whatever were the instructions of Dr. Schnee. On receiving a summons from the commander of H.M.S. "Fox" for unconditional surrender Herr Auracher went on board, stated that Tanga was an open and undefended place and said that he must obtain special instructions. The British, therefore, refrained from bombarding the town, and meanwhile von Lettow was hurrying down reinforcements by rail. On the evening of Nov. 2 Gen. Aitken landed one and a-half battalions at Ras Kasone, two m. east of the port. It advanced through dense jungle to the outskirts of the town, became heavily engaged and had to fall back. The British were reinforced and the fight was renewed on Nov. 3. It was intensive, but in the evening the officer in command, Capt. Baumgart, believing that Tanga could not be held against another attack, had collected his force four m. W. of Tanga, leaving parrots only in the town. That evening von Lettow arrived, passed through deserted Tanga, and reconstituted the British camp at Ras Kasone. Von Lettow's plans for the morrow were, while defending Tanga itself, which he reoccupied with two companies of Europeans, to place most of his troops in the bush along the Ras Kasone-Tanga road and attack the enemy in flank. The fight was renewed on the fourth. The British and Indian troops advanced through coconut and rubber plantations and entered Tanga town. By this time fighting was severe and general, and soon after 3 P.M. von Lettow delivered his counter-attack on the British left, which, he states, he was able

to outflank by means of his two reserve companies. Supported by machine-gun fire, this outflanking force was able to push its attack home, and soon the British were in full retreat to Ras Kasone. The fight continued in the dense bush till after night-fall, the Indian and British troops eventually getting back to their camp. The next day, Nov. 5, they were re-embarked, and taken to Mombasa. The attack on Tanga had been a complete failure: The casualties in Aitken's force were, according to an India Office statement, 795, including 142 British officers and men. Sixteen machine-guns were lost. Von Lettow gives the German force engaged as "little more than 1,000." Fifteen Germans and 54 askaris were killed. The number of wounded was not stated. After this action Aitken was removed from his command, but in Dec. 1920, after a fresh investigation by the War Office, he was declared "not guilty of culpable negligence . . . and should not be held responsible for the failure."

The simultaneous attack on Longido, N. of Kilimanjaro, also failed. The Germans—about 800 strong—were strongly posted, and covered the only permanent water supply available. Stewart's attacking force numbered about 1,500. After a night march of 15 m. across a waterless region, the action began on the morning of Nov. 4 and continued till 7:30 P.M. The whole movement—typical of many operations in this theatre of war—was tersely summed up by an officer who wrote, "We marched all night, attacked at dawn, fought all day, and then having failed to see the Germans out, came back here as we had no water."

Following the failure at Tanga no new general offensive was undertaken by the British until the early months of 1916. The intervening period was one of preparation on both sides, with, on the part of the Germans, frequent and sometimes successful attempts to raid the Uganda railway, and on that of the British, defensive and retaliating raids of the same kind. Of the engagements of this period that at Jassin was the most notable. Following the failure of the German march on Mombasa, the British force on the coast advanced S., crossed the German frontier and occupied (Jan. 2 1915) the buildings of Jassin plantation, which was garrisoned by some 300 Indian troops. Von Lettow thinking that a land attack on Tanga was intended got together a force of 1,500-1,600 men, and attacked Jassin on Jan. 17. After 4 hours' fighting, the Indian troops, having expended all their ammunition and being without water, surrendered. Attempts by the King's African Rifles (in camp 10 m. distant) to relieve them failed. But the German losses, especially in European officers, were serious, and the expenditure of ammunition made a heavy inroad on von Lettow's small stock.

The period of preparation was spent on the British side largely in raising new troops and in the organization of transport. In April 1915 Col. M. I. Tighe, Indian army, with the local rank of Major-General, was appointed to command the troops in East Africa and to prepare for the new offensive. His force was increased by two newly raised white regiments, the 2nd Rhodesian and "Dracott's Scouts" (15th Batt. R. Fusiliers). While parrying the raids on the Uganda railway—which were numerous and daring, but taken as a whole, ineffective—Gen. Tighe organized occasional offensives, such as the successful attack (June 1915) on Bukoba, the German base on Victoria Nyanza for operations against western Uganda. This raid was made by Gen. J. M. Stewart, and it affords an illustration of the great distances to be covered in the East African operations. Nairobi, headquarters, was 327 m. by rail from Mombasa, the base, and 237 m. from Kisumu, railhead on Victoria Nyanza. Hence Stewart's force had to go by steamer 200 m. before reaching Bukoba. To aid his operations Gen. Tighe began the building of a railway and pipe line across the 70 m. of desert between Voi, on the Uganda railway, and his advanced posts near Taveta.

The other theatres of operation in East Africa were much worse off for means of communication. To reach the German frontier bordering Nyasaland, Rhodesia and the Belgian Congo was a journey of from 2,000 to 3,000 m., including hundreds of miles to be covered on foot or by animal and mechanical transport. This involved the employment of vast numbers of camels

#### The Tanga Expedition.

Part of Progress.

in regions where local supplies of food were often non-existent. Thus in northern Rhodesia a road 400 m. long had to be cut through trackless bush, in which the areas of cultivation were infinitesimal. The Germans were better off in that, besides their two railways,<sup>1</sup> they had constructed several main roads before the war, and during the war other roads and some light railways were laid down. And the German troops had not such long distances as had their opponents to cover on foot. Nor were they troubled by lack of food (at least not before 1917). The natives had been compelled to establish large food depôts at all military stations, while Usambara, in or near which the bulk of von Lettow's force was quartered for 22 months, was a land of plenty. But the necessity that they were under of guarding the coast and to a lesser extent the N.W. and S.W. frontiers, while keeping their main forces in the principal theatres about Moshi, imposed upon them a great deal of movement in a more or less N. and S. direction for which—apart from the command of Lake Tanganyika—few facilities existed. For instance, movement of supplies or stores by carrier from the Central railway to the Usambara railway took 12 days, and from the Central railway to Lindi in the S. not less than three weeks.

Throughout 1915 von Lettow's chief concern was the increase and training of his forces. At the outbreak of war he had, as has been stated, just under 5,000 men (a figure which included the police as well as the troops proper). This number had been increased by Feb. 1916, when the German force was at its maximum strength, probably over 20,000. Exact figures cannot be given as the number of carriers and batmen who acted as combatants is unknown, but the rule was to arm 15% of them. Von Lettow himself says that the total numbers enrolled during the war were "about" 2,000 Europeans and 11,000 askaris (natives); the figures of casualties and captives show that the number of whites on the German side was nearer 4,000, and an official German return gave 2,217 Europeans as under arms in Aug. 1915.<sup>2</sup> The Europeans included most of the German settlers in Usambara and other districts, almost all of whom were ex-soldiers and many ex-officers; a few Boer settlers; German residents at Zanzibar who had been allowed by the British to cross to the mainland; some 500 sailors from ships in harbour, including over 400 men of the Imperial navy, and a few visitors to Dar-es-Salaam. These last had come to attend fêtes to mark the formal opening of the Dar-es-Salaam-Tanganyika railway, and among them was a retired Prussian officer, Maj.-Gen. Wahle, who rendered von Lettow good service. The German forces were organized in companies normally consisting of 200 askaris and 16 Europeans; a few of the companies were composed almost entirely of whites, two companies were mounted. The askaris were drawn from the most warlike tribes of the country, and were very well treated. Von Lettow himself was ever careful of their needs and shared their hardships on campaign. He won and retained throughout their respect and devotion. Besides his regular force von Lettow had in the earlier stages the help of various levies; and the anti-Moslem policy of Dr. Schnee having been reversed he also obtained the support of a number of Arabs (support which proved of little value). His movements were not, for a considerable time, hampered by disaffection among the natives; some tribes near the border of British East Africa were deported because of doubt as to their sympathies, and the converts of the British missionary societies were in general regarded as enemies and were very badly treated, many being executed. Fear of a native rising was felt among the Germans when the war broke out, but the fear proved groundless. "It was not" (writes von Lettow) "till the enemy had

penetrated the country that the natives became a real danger to us; and then it was indeed very great. The native has a fine sense of the transfer of real power from one hand to the other." Even then, with the natives hostile, the askaris (who had with them their women and children and carriers) were faithful to their leader, and more resolute than many of the Germans.

That they obviously had the advantage inspired the German native troops with confidence, and the hard training they had between Nov. 1914 and March 1916 made them, as the event proved, very formidable opponents in their own country of white and Indian troops. And months before the onslaught of Gen. Smuts they had also been rearmed with modern weapons.

On Feb. 28 1915 a blockade of the whole coast of German East Africa was proclaimed, and the British Government stated that "ample steps had been taken to make the blockade thoroughly effective." The task of the reinforced <sup>Blockade Runners.</sup> Cape squadron under Vice-Adm. King Hall in watching 600 m. of coast line provided with many excellent natural harbours was difficult, and in fact several vessels got through. In Dec. 1914, before the blockade was proclaimed, Dar-es-Salaam was visited and the German ships which had taken refuge there sunk. In April 1915, when the Germans were in greatest need of more ammunition, the blockade was broken in a remarkable manner. The "Rubens," an English ship of 3,000 tons seized at Hamburg, had been loaded with arms and ammunition, had eluded the blockade of the North Sea, and on April 4 (its arrival was expected) was sighted by H.M.S. "Hyacinth" four m. off Mansa Bay, N. of Tanga. The "Rubens" got into the bay, severely damaged and on fire. The crew fled ashore; the ship was boarded by bluejackets, who found her timbered up and battered down; the party was recalled and more rounds having been fired into the vessel "the admiral . . . steamed away under the impression that she would burn herself out" (Brig.-Gen. J. H. V. Crowe). Subsequently the Germans salvaged at leisure nearly the whole of her cargo, though a great part of the cartridges had been damaged by sea water. But there were enough Mauser '98 rifles to rearm the force, which previously, for the most part, used the M 71 rifle. (A year later, at another critical period of the war, the Germans were again rearmed, by another blockade runner.)

The operations against the "Königsberg" also resulted in a valuable addition to von Lettow's armament. The cruiser had remained shut up in the shallow waters of the Rufiji, but in July 1915 the light-draught monitors "Severn" and "Mersey," sent specially from England, succeeded in setting it on fire. The cruiser was then blown up by Capt. Looff, who with his officers and crew joined von Lettow. The "Königsberg's" armament, which included 10 4.1-in. guns, was all salvaged, and these 4.1-in. guns formed von Lettow's heaviest ordnance.<sup>3</sup> The Germans also recaptured with its guns the 300-ton steamer "Adjutant" (originally taken by the British at Dar-es-Salaam), which had run aground off the Rufiji in Feb. 1915. The "Adjutant" was transferred by rail to Lake Tanganyika.

Plans for the conquest of German East Africa took shape in the summer of 1915, but their execution had to be delayed until Britain could put a sufficient force in the field. This force was not forthcoming until the close of 1915, when Gen. Botha, Prime Minister of South Africa, having conquered German South-West Africa, agreed to provide a force for service in East Africa. At the time Gen. Tighe had under him 10 regular infantry regiments supplied by India, including the 40th Pathans and the 29th Baluchis brought from France, a squadron of the 17th Lancers (Indians), Imperial Service troops, the 27th and 28th (Indian) Mountain Batteries, and the Calcutta Volunteer battery. Of white troops there were, besides the two regiments

<sup>1</sup> The Usambara line (Tanga-Moshi) and the Central railway (Dar-es-Salaam-Tabora-Tanganyika).

<sup>2</sup> Dr. Ludwig Deppé, a surgeon with von Lettow's force, who appears to have kept careful records, states that there were 3,629 casualties among the whites up to the end of Nov. 1917. He puts the highest total of the German force in the field at any one time at 23,000 whites and 15,000 askaris. These included the non-combatant services.

<sup>3</sup> In like manner the 4-in. guns of the disabled "Pegasus" were restored and added to Gen. Tighe's artillery. It is noteworthy that the captain of the "Königsberg" had the breech-blocks of his guns thrown overboard, but they were salvaged by the officer commanding the land detachment at the Rufiji delta.

raised by the settlers in East Africa, the 2nd Rhodesian Regiment, the 25th Batt. Royal Fusiliers and the 2nd North Lancashire (the only regular British infantry unit in East Africa). There were also the battalions of the King's African Rifles, but at that time the value of negro troops was not sufficiently appreciated. Though they were best adapted for warfare in equatorial Africa—and ultimately bore the brunt of the fighting—and though von Lettow had shown the way, the raising of new native regiments was neglected at first by the British.

The plan adopted by the British in conjunction with the Belgians was for a concerted attack on three sides. The object was not only to defeat the enemy, but effectively to occupy the country, so as to render impossible the splitting up of the German forces "into guerrilla bands doubling back in all directions" (Gen. Smuts). This aim was achieved with one remarkable exception, the Wintgens-Naumann raid (see p. 883, note). But when von Lettow was driven eventually into Portuguese territory the whole remaining German force became a guerrilla band, with an unlimited field for doubling and redoubling. The scheme evolved in 1915 was to strike the main blow with the force in British East Africa, whilst the Belgians were to operate in the north-west and a second British force in the south-west of the German protectorate. This second force was gathered on the Nyasa-Rhodesia borders, and Brig.-Gen. Edward Northey assumed command of it in Jan. 1916. When, in March 1916, the Portuguese entered the war, they undertook to guard the southern frontier of German East Africa. Thus the Germans had enemies on every side, and had no opportunity (which the Germans in Cameroon took) of escaping capture by retirement into neutral territory.

When Gen. Botha's Government undertook to send forces to East Africa it had to rely upon volunteers to redeem its promise.

But a force already organized and originally destined for service in Europe—the 2nd South African Infantry Brigade (under Brig.-Gen. P. S. Beves) was diverted to East Africa. A mounted brigade under Brig.-Gen.

J. L. Van Deventer, and a brigade consisting of five batteries of S.A. Field Artillery, with all necessary administrative and other units, were also formed so that the South African contingent was complete and self contained. Later this contingent was increased by another infantry brigade, a second mounted brigade and the Cape Boys Battalion<sup>1</sup> (under Col. Morris). All these troops except the 2nd mounted brigade had reached East Africa by Feb. 1916, before the offensive began.

When South Africa furnished this contingent—the largest body of white troops which had taken the field in tropical Africa—the Home Government offered the command to a South African, Gen. Smuts. Smuts was Minister of Defence in the Union Cabinet; the political situation in South Africa was uncertain and he declined the offer. Gen. Sir Horace Smith-Dorrien was then selected for the post, but while at the Cape on his way out, in consequence of ill health, he resigned his appointment. Again appealed to, Gen. Smuts accepted the command and reached Mombasa on Feb. 19. He adopted, with some modifications, the plan of campaign which Gen. Tighe had originated.

Gen. Tighe had had a very difficult task, and the *moral* of his force, predominantly Indian, had suffered through being so long on the defensive. It altered completely with the opening of the offensive. Before the arrival of Gen. Smuts the railway across the waterless waste between Voi and Taveta had been taken to Serengati, within five m. of the German post on El Olorobo (otherwise Salaita hill), which blocked the main approach to the Taveta gap. Skirmishing had been going on around Salaita since March 1915. The hill was without water, which was taken to the garrison from Taveta in donkey carts. "Strangely enough," wrote von Lettow, "it did not occur to the enemy to interfere with it [the transport] and thus render the mountain untenable." The first action in which the South Africans took part was an attack on Feb. 12 1916, on Salaita. Brig.-Gen. Malleston with the 1st East African and 2nd South African In-

fantry Brigades, supported by artillery, assaulted the strongly entrenched German positions, approached through them back. Little progress was made and the Germans, reinforced from Taveta, counter-attacked and compelled Gen. Malleston to retreat. The British casualties were 172, of which number 139 were among the South Africans. They suffered through ignorance of the new conditions. "The South African Infantry," wrote Gen. Smuts, "had learned some invaluable lessons in bush warfare, and also had opportunity to estimate the fighting quality of the enemy."

Gen. Tighe intended to force the enemy from the Taveta gap by a double movement. One force, under Gen. J. M. Stewart, was to sweep round Killimanjaro from the north; another, under Gen. Malleston was to attack Taveta. The forces were to join hands at Kahe, a place on the Tanga railway S. of Moshi. Gen. Stewart, who had the 1st East African Division (infantry) and Van Deventer's mounted brigade, was at Longido, some 50 m. from Kiljajo, the terminus of the Magadi branch of the Uganda railway and Stewart's base for supplies. The chief alteration in Gen. Tighe's plans made by Gen. Smuts was to bring back Van Deventer's mounted brigade to the Taveta side and to use it for a turning movement which would render a frontal attack on Salaita hill unnecessary. The infantry which were to follow up Van Deventer's movement consisted of the 2nd East African Division, of which Gen. Tighe was placed in command.

Four days after reaching Mombasa Gen. Smuts telegraphed to Lord Kitchener that he was prepared to carry out the occupation of the Killimanjaro area at once; two days later (Feb. 25) Kitchener's sanction for the operation was received. There was good reason for haste as the rainy season was approaching, and during the rains operations might be (and in fact proved to be) impossible. Von Lettow was well aware of the enemy's movements, and as early as Aug. 1915 had made preparations in view of having to abandon the Killimanjaro and Usambara regions. These preparations included the removal of all military stores. For this purpose a light railway was built south from Mombo station on the Tanga railway to Handeni (40 m.), whence a wagon road went to Kiamba on the Central (or Tanganyika) railway. Up to nearly the end of 1915 von Lettow had thought that the new British offensive might be a landing at Dar-es-Salaam or Bagamoyo; afterwards there was no doubt that it would be in the Killimanjaro region. To meet the attack he had, he states, a force of "about 4,000 rifles" under Maj. Kraut (the British estimated that Kraut had 6,000 rifles, 16 naval and field guns and 37 machine-guns). About 1,000 rifles were concentrated to dispute any advance from Longido.

The Germans were apparently unprepared for the turning movement executed by Van Deventer's mounted men, who got behind Taveta, and forced the enemy to evacuate Salaita hill, though on this point von Lettow asserts "our want of artillery obliged us to look on quietly while the enemy executed unskillful movements at no great distance from our front."<sup>2</sup> Van Deventer's movement began on March 8, and on the next day his men were astride the Moshi road behind Taveta. Salaita hill was evacuated by the Germans on that day and new positions were taken up by them covering the gap between the North Pare mountains and Killimanjaro. Von Lettow himself, with the bulk of his force, was at Himo, five m. from his front, and he was aware that behind him Gen. Stewart's column was advancing. That column, in Gen. Smuts's plan, was to cut off von Lettow's retreat, and in view of the greater distance it had to cover had started from Longido on March 5. Stewart's column met with many difficulties, and though it had no serious encounter with the Germans its progress was much slower than had been anticipated. Meanwhile the attack on the position west of Taveta was delivered on March 11. The road to Himo and Kahe passed between two hills, Baeta and Latema. Maj. Kraut held both

<sup>2</sup> It is to be observed that von Lettow's record of the campaign appears not to have been written till after the close of the war, and there are indications that knowledge subsequently gained colour his record of events.

<sup>1</sup> The "Cape Boys" are coloured men, all with a strain of white blood, from the Cape Province.

hills and the pass or nek between them; no turning movement was possible and the order was given to Gen. Malleon, commanding the 1st Brigade of the 2nd East African Division, "to clear up the position and, if possible, make good the nek." The whole region was densely bushed. The advance began at 11:45, and the 130th Baluchis and the 3rd King's African Rifles were sent forward to seize a spur of Latema. The defence was very strong and by 4 P.M. little progress had been made. At this hour, writes Gen. Smuts, "Gen. Malleon, who was seriously indisposed, asked to be relieved of his command." Gen. Tighe then assumed personal direction of the operations. The 2nd Rhodesians, the 3rd King's African Rifles, and the 130th Baluchis now attempted to gain the Latema ridge. The enemy, well hidden in the bush, and supported by accurate machine-gun fire, kept, however, possession of the ridge. Finally, the 5th and 7th South African Infantry Battalions, brought up as reinforcements and led by Lt.-Col. Byron, were sent in to make a night charge with the bayonet. Here and there small parties, which became isolated, gained the crest. Col. Byron got within 30 yds. of the main enemy position, but with 20 men only, and was forced to retire. Tighe thereupon dug in astride the road to await daylight. At 4:30 A.M. March 12 Smuts ordered Tighe to draw back his force. This operation was in progress when news came that the enemy was in full retreat. Von Lettow states that about 7 P.M. on the 11th a telephonic message from the Raeta position informed him that the enemy had penetrated into the position in great force and that to avoid the risk of having his communications cut he ordered the troops with him, forming his left wing, to fall back towards Kahe. When he discovered the mistake made it was too late to alter his dispositions. Maj. Kraut then evacuated the Latema-Raeta position, and the whole force retired to the Kahe position, abandoning Moshi and Kilimanjaro. Gen. Stewart's division had not played the part expected; it was not until March 13 that it reached Bomba Jangombe, 25 m. N.W. of Kahe. Here Gen. Stewart was informed by telegram that the enemy had already avoided encirclement, and his force was brought into New Moshi on the 14th. On the 19th Gen. Stewart left for India. Later experience showed that the difficulties of encirclement were greater than then supposed.

Von Lettow's new position—known as the Kahe-Ruwa—stretched, S. of the Moshi-Taveta road, from Kahe railway station, near which the Ruwa (Pangani) crossed the railway, eastward along the northern end of the Pare mountains, through a region of forest, bush, swamps and rivers. On March 18 he was attacked from the Latema Nek direction by a force under Brig.-Gen. S. H. Sheppard (who had commanded the 2nd East African Brigade under Gen. Stewart) and on March 20 Gen. Van Deventer was sent westward from Moshi to turn the enemy's rear at Kahe. He reached and—after some sharp fighting—seized Kahe station on the 21st, but owing to the difficulty in getting his force across the Pangani could not cut off the enemy. On the same day Sheppard fought a very determined and apparently indecisive action on the northern front—a South African Brigade which was to have aided him "was so impeded in the dense bush that it was unable to exercise any influence on the fight" (Gen. Smuts). But under cover of night the German force was withdrawn to Lembeni station, 20 m. S. of Kahe. Von Lettow retired in perfect order with practically all his stores and guns, except one of the "Königsberg's" 4.1-in. guns, which was blown up.

The fight of March 21 marked the conclusion of the Kilimanjaro operations. They had opened the door into German East Africa and had greatly inspired the British. They had done more, for though Von Lettow's force was intact and its *moral* still high, its supply of ammunition had been greatly depleted. But at this critical moment another ship ran the blockade and brought the Germans most welcome supplies, including four 4.1-in. field howitzers, ammunition for the "Königsberg's" big guns, 5,000,000 rounds of .98 small-arms ammunition, 12 machine-guns, medical stores, provisions and clothing (for women as well as men). The ship, the "Maria," which had come 'twa South America, the East Indies and Madagascar, entered Sudi Bay, near Lindi, in the far south of German East Africa, in the middle

of March unobserved by the British patrolling vessels. She was discovered early in April, fired into and damaged. But she completed the discharge of her cargo, and got clear away. The value of this reinforcement to von Lettow is difficult to over-estimate.<sup>1</sup>

The military problem as it presented itself to Gen. Smuts and to Col. von Lettow respectively was very different. Smuts knew that the Belgians were ready to strike from the N.W. and the Nyasa-Rhodesia force from the S.W. and von Lettow was also aware of the fact. But in so large a country as German East Africa those operations were not likely for some time to affect the main forces. Von Lettow's position was comparatively simple; he could not prevent the enemy from developing his offensive in the manner he chose, but with his superior mobility he could adapt his movements to meet his foe's tactics.

Gen. Smuts had four possible alternatives: (1) to advance from Victoria Nyanza on Tabora, the chief town in the interior (this was ruled out as it was thought, and proved to be the case, that the Belgians could deal with Tabora); (2) follow the enemy down the Tanga railway through Pare and Usambara (this was rejected as it was the enemy's chosen ground, and where he was strongest); (3) advance direct inland from Kilimanjaro; (4) land a force at Dar-es-Salaam and advance along the Central railway. Gen. Smuts chose the third alternative; whether it was better than the fourth is questionable. An advance along the line of the Central railway had obvious advantages. The railway traversed the protectorate in an east-west direction from end to end; its occupation would have cut the German forces in two and materially helped the operations of the Belgians and Gen. Northey. Dar-es-Salaam, the ocean terminus of the railway, lay at the mercy of the British navy; it was the capital of the protectorate; its occupation would have much political as well as military importance, and would have given the British a sea base 200 m. nearer South Africa than Mombasa and reduced land communications to a much greater extent. And the shortening of the lines of communication was a vital matter. Smuts, however, decided against Dar-es-Salaam "partly because the prevalence of the S.E. monsoon at that period (April) made a landing of a large force on that coast an operation of great difficulty, and even danger, partly because a prolonged campaign on the coast immediately after the rainy season would mean the disappearance of a very large percentage of my army from malaria and other tropical ailments."

Moreover, von Lettow by retiring along the Tanga railway had left the road into the interior "wide open and unguarded." At that time, April 1916, it was not realized that the climate of the interior was little less deadly than that of the coast, and that whatever course was adopted a large proportion of the army—especially among the white troops—would be affected by malaria and other tropical ailments. Also Gen. Smuts was misinformed as to the extent and severity of the forthcoming rainy season. Of the difficulties of communication he was well aware, and slightly to lessen them the railway from Voi to Taveta was carried through the Latema gap and joined to the Tanga railway at Kahe. This railway was completed on April 25 1916. It was cut through swamps and virgin forest and thousands of men had to be employed to keep the rails from sinking in the mud. Kahe, by rail, was 210 m. from Mombasa; from Kahe the advance into the interior had to be made by other means of transport. Smuts made large use of motor lorries.

Smuts's plan for his new campaign was, briefly, as follows: A mounted force under Van Deventer was to make a rapid advance

<sup>1</sup> A remarkable attempt to carry medical and other comforts to von Lettow in 1917 by air failed. Zeppelin L59 (known as "The Balkan Terror") under von Butlar, carrying supplies, left Yambol, Bulgaria, on Nov. 21 1917, crossed the Mediterranean, and keeping along the edge of the Libyan Desert, reached the latitude of Khartoum on Nov. 23. Then von Butlar received a wireless message "Return East Africa occupied." He got back to Yambol on Nov. 25, after a non-stop flight of 4,500 m. By the Egyptian authorities it was thought that the L59, which was observed passing over the oases in the Libyan Desert, intended to bomb the Assuan Dam.

*Alternative Plans of Campaign: Smuts's Choice.*



S. from Arusha (a place 40 m. W. by S. of Moshi) to Kondoa Iringa—the chief strategic point in the interior of the northern part of the country—thence advance to the Tanganyika railway and turn E. along that line to Morogoro. Smuts himself, with the rest of his force, after clearing as much of the Pare and Usambara regions as was necessary for his purpose, was to turn S., parallel to the coast and E. of Van Deventer's line of advance, also converging on Morogoro. It was hoped thus to corral von Lettow and bring him to a decisive engagement. Smuts had reorganized his forces since the March operations, and no longer had the aid of Gen. Tighe, who was given a command elsewhere and created a K.C.M.G. Smuts formed his army into three divisions, the first under Maj.-Gen. A. R. Hoskins (Inspector-General King's African Rifles), the second under Van Deventer, the third under Maj.-Gen. Coen Brits. The first division was made up of the two East African Brigades; the two other divisions were composed of South African troops, supplemented by batteries of Indian and other artillery. On April 5 Van Deventer

**Van Deventer's March to Kondoa.**

took the road across the Masai Steppe to Kondoa, which place he occupied after a smart engagement on April 19. En route the garrison of Lol Kissaie, 17 Germans and 404 askaris with two machine-guns, had been surrounded and forced to surrender. It had been a brilliant march of some 200 m., but Van Deventer had lost hundreds of animals through horse-sickness, and though only some 80 m. from the Central railway he could advance no further. Then the rainy season set in and cut off Van Deventer for several weeks. Meanwhile von Lettow made rapid preparations to meet Van Deventer's thrust. Three companies were brought from near Lake Kivu in the N.W. and by steamer on Lake Tanganyika to Kigoma, whence they took train to Saranda (the nearest point on the railway to Kondoa), while von Lettow himself with 15 field and two mounted companies marched from Korogwe on the Tanga railway to Kimamba on the Central railway—a distance of 125 miles. Maj. Kraut remained in charge of the force left in Usambara. The rains began while the troops were on the march, but by the beginning of May von Lettow and his force had occupied a strong position a little S. of Kondoa. A good deal of minor fighting followed but neither side made a general attack. (In May, owing chiefly to the privations caused by the rains, Van Deventer could barely muster 3,000 rifles—a number inferior to that of von Lettow.) And in June, during the period of waiting, the Belgian advance towards Tabora began to have effect on von Lettow's own position. Gen. Smuts was also moving. His advance could not begin until May 18, the rains having turned much of the country into a lake. It took an armoured-car detachment under Lt.-Comm. Whittall, R.N., sent to reinforce Van Deventer, 35 days to cover 75 m. (in the dry season the journey took three days).

When Smuts advanced Maj. Kraut retired, skilfully, by the railway to Handeni. Equally skilful was Smuts's advance. The main column under Gens. Sheppard and Beves marched, through the densest bush, down the left bank of the Pangani, W. of the Tanga railway; a smaller force under Gen. Hannington followed the railway; a third column under Lt.-Col. T. O. Fitzgerald entered the Pare mountains through a gap (the Ngulu gap) on the east. Outflanked, Kraut had no option but to retire; he had strongly fortified the railway line, but had, apparently, not believed that an advance along the fever-haunted valley of the Pangani was possible. By June 15 the conquest of Usambara was completed by the occupation of Korogwe, whence the Tanga railway descends to the coast plain. Smuts put off the occupation

**Gen. Smuts's Main Operations.**

of the coast region, and had already with his main force turned S., and on June 10 Handeni was occupied. On June 24 a determined effort was made to round up Kraut's force, the Germans being attacked simultaneously on three sides. In this action the Kashmiris and the 25th Fusiliers (familarly known as "the Old and Bold") earned special distinction. The Germans fought with great determination, and when the day was lost scattered in the bush and thus escaped. They reformed in strong positions in the Nguru hills.

After this fight Gen. Smuts was compelled to halt, forming a large standing camp on the Msiha river. The force had covered about 250 m. since May 22; water was short and the transport had reached the limit of its capacity. Malaria had greatly reduced the force—several units had no more than 30% of their original effectives—and the troops were on half rations. The interval of enforced idleness at Msiha camp was utilized in clearing Smuts's left flank; that is, the northern coast region. This was done by Indian and African troops under Brig.-Gen. W. F. S. Edwards (Inspector-General of Communications), with the help of the Cape squadron, now under Rear-Adml. E. F. Charlton. At this time Gen. Smuts had already reached the conclusion that white troops were not best suited for campaigning in tropical Africa (nor were the Indian troops particularly suited for the work), and that a much larger negro element was needed. By his direction the raising of new battalions of the King's African Rifles was undertaken, but the need was urgent for immediate reinforcements by trained black soldiers. These were found in West Africa. The Gold Coast Regiment had volunteered for service soon after its return from the Cameroon campaign; its offer was accepted and it sailed in June for East Africa and was in action in July. At the end of Aug. volunteers were called for a Nigerian overseas contingent and there was a ready response, but the Nigerian Brigade could not reach East Africa till Dec.-Jan. 1916-7. Meantime a battalion of the West India Regiment and the Gambia Company had joined Smuts. The coast operations, in which the navy played a great part, were successful; Tanga was occupied on July 7, Pangani on July 23, Sadani on Aug. 1 and Bagamoyo—the terminus of the old slave road from the great lakes—on Aug. 15. The British base was removed to Tanga, a saving of 75 m. sea voyage and over 200 m. rail transport. Dar-es-Salaam was occupied on Sept. 4, but it took three months before the port could be used as the new base.

While Smuts was still at the Msiha river von Lettow had brought most of his force from Kondoa to the Nguru hills. As attempt to surprise the British camp was unsuccessful owing to "the remarkably dense bush." When on June 24 Van Deventer reinforced, resumed his offensive the German detachments on his front gave way, nor was their retreat marked by the skill usually displayed by the Germans in their retirements. Van Deventer was delayed by the difficulties of transport, but by the end of July he was in possession of some 100 m. of the Central railway—from Kilimantinde to Kikombo,—and on Aug. 9 had concentrated his division for an advance E. on Morogoro. Farther W. the Belgians were beginning to close in on Tabora. Van Lettow was obliged to leave his forces in that region to their fate, but (at the end of June) he had sent reinforcements to the detachments opposing Gen. Northey's advance from the south. His own position now appeared critical. He withdrew Maj. Kraut and most of his force S. to Kilosa, on the railway, W. of Morogoro, leaving Capt. Schulz, with a few companies, to oppose Gen. Smuts, who resumed his advance on Aug. 5. Von Lettow's plan was to get away with as much of his stores as he could. Kraut's force did not remain at Kilosa, but crossing the railway struck S. in the direction of Mahenge, a military station in the middle of a healthy plateau, to which plateau the detachments which were opposing Northey were falling back.

Gen. Smuts's effort, to use his own words, "to bottle the enemy up in Morogoro" failed. Schulz, after fighting an action at Dakawa on the Wami river on Aug. 16, retired on Morogoro, leaving a broken bridge across the Wami. Smuts sent forces to outflank von Lettow, but in vain. When on Aug. 26 the British occupied Morogoro it was to find it abandoned, and partly destroyed, by the enemy. Von Lettow had gone with his force into the Uluguru mountains, which lie immediately S. of Morogoro, by a track the existence of which was unknown to the British. With von Lettow was Dr. Schnece, the governor.

Gen. Smuts had taken measures intended to prevent von Lettow getting away from Morogoro by roads leading E. and W. of the Uluguru hills; he had not anticipated a retreat into the hills themselves. Brig.-Gen. Enslin was sent with the 2nd Mounted

Van Lettow's Retreat.

Brigade to guard the western exit from the hills. This movement van Lettow had foreseen and had posted troops to meet an advance in this direction. Meanwhile the rest of his men, with as much of the stores as could be collected, were being moved through the mountains to Kissaki. To prevent van Lettow's escape E. of Morogoro Smuts's main force had crossed a waterless desert 25 m. long, a move which the enemy had not expected, and it was this march which caused the hurried evacuation of Morogoro. Exhausted as were his men Smuts determined to make another effort to corner van Lettow. For some three weeks very bitter fighting continued in the Uluguru hills, in which the Germans gained several successes, but on Sept. 15 Kissaki, with considerable stores, was captured by the British. Van Lettow could neither remain in the fertile and healthy hill region nor escape W., but he was able to retreat S.E. towards the Rufiji, where he formed an extensive camp on the further side of the Mgeta river, which he continued to occupy for months. In short, the limit of endurance had been reached by Gen. Smuts's troops, further pursuit was impossible and the second rainy season was approaching. "Gen. Smuts," writes van Lettow, "realised that his blow had failed. He sent me a letter calling upon me to surrender, by which he showed that as far as force was concerned he had reached the end of his resources."

Van Lettow is entitled to his deduction, but by his energy and driving force Gen. Smuts had surmounted obstacles which appeared insuperable, and in conjunction with the Belgians and Northey had conquered fully two-thirds of the German protectorate, including the chief areas of European colonization and both the railway lines. This had been done in a period of seven months, and was a very considerable achievement. Civil administrations were set up in the conquered regions.

The operations of the Belgians had been carefully planned and were thoroughly successful. While such troops as were available were engaged in defending, as best they could, the Congo frontiers, a special force of a little over 10,000 men—all natives of the Congo—was raised and officered by Europeans. All supplies for this force, except food, had to be imported, a long and tedious process. A railway completed in Sept. 1915 from the upper Congo to Lake Tanganyika gave some help as, for example, when two small, fast and comparatively heavily armed British motor boats were taken from Cape Town to Tanganyika in sections. These boats took nearly six months to complete the journey of some 3,000 m. from the Cape to Tanganyika. Launched on the lake in Dec. 1915 they soon obtained mastery of its waters by capturing, sinking or bottling up the enemy steamers. This achievement was of much assistance to the Belgian operations.

The organization of the new Belgian force was confided to M. Tombour, acting Vice-Governor-General of Katanga, and an ex-officer, who in Feb. 1915 was made commander-in-chief of the Belgian Congo troops with the rank of Colonel (subsequently Major-General). All the fighting men were infantry and gunners—there were, all told, 60 machine-guns and 72 field pieces. The force was divided into a Southern Brigade (under Lt.-Col. Olsen) and a Northern Brigade (under Col. Molitor). Olsen's brigade was stationed along the Rufiji river, between lakes Kivu and Tanganyika; Molitor's N. of Kivu along the Congo-Uganda border. Tombour's headquarters were established at Kibetsi, just N. of Lake Kivu. Molitor's brigade was partly stationed in British (Uganda) territory. It had the help of the Congo Carrier Corps, consisting of natives of Buganda (of whom 8,429 served in the corps), while Gen. Smuts made himself responsible for supply arrangements to Molitor's headquarters, which were at Lutobo, 150 m. W. of Victoria Nyansa. This was a great advantage as from Mombasa to Lutobo is barely 1,000 miles.

The defence of the region had been entrusted to Maj.-Gen. Wähle, whose "western command" extended from Lake Nyansa to the Uganda frontier. Von Lettow had withdrawn part of the troops to strengthen his main force. Wähle, whose headquarters were at Tabora, was instructed not to risk a decisive action, but,

when compelled, to fall back on Malindi. From about mid-July to the end of Oct. Wähle was cut off from his chief.

The terrain for the first part of the Belgian operations was extraordinary. North of Kivu rise the Mzimba mountains, a range of lofty, active volcanoes; farther N.E. extends a tangled mass of hills, for the most part heavily wooded, and numerous small lakes and rivers. On the German side was the mountainous, fertile, and thickly populated region of Ruanda—but newly conquered and still preserving its native governments. A narrow passage between Lake Kivu and the Mzimba mountains afforded the only practicable route for the invasion of Ruanda from the N. side of the lake; from the S. side there was an easier approach. Col. Molitor's plan was to attack from both sides of Kivu and to make a third advance from Lutobo. The campaign began on April 4 with holding attacks by Maj. Rouling at the N. end of Kivu, where the Germans, under Capt. Wintgens, held very strong positions at Kisenji along the little river Sebwa. Then the two other columns were set in motion, and to avoid being trapped Wintgens had to evacuate the Sebwa lines. By the middle of May the Belgians by their converging movements had "nipped off" Ruanda. They next repeated the manoeuvre on a larger scale. Olsen crossed the Rufiji at the N. end of Tanganyika and pressed E.; Molitor sent columns S.W. to join up with him and at the same time sent other columns S.E. to Victoria Nyansa, which was reached on June 27. Capt. Godovius, the German commander in Kasagwe, who for nearly two years had conducted guerrilla warfare with the British Lake Detachment near the western Uganda frontier, falling back, tried to pierce the Belgian lines. His detachment sustained very heavy losses, and Godovius, severely wounded, was taken prisoner. The detachments under Wintgens, though badly mauled, escaped the Belgian cordon. By the middle of July the Belgian columns had secured the Tanganyika-Victoria Nyansa line and were ready for a further advance. Olsen's brigade marched S. parallel to Lake Tanganyika on Kigoma—the lake terminus of the railway from Dar-es-Salaam and the port of Ujiji.

In its harbour was the "Graf von Götzen"—launched in 1914 and the biggest boat ever seen on Tanganyika, the "Adjutant" (the vessel brought in sections from Dar-es-Salaam), and the tug "Wami." From June onwards they had been bombed by British seaplanes manned by Belgians. Olsen's brigade occupied Kigoma on July 20 and Ujiji on Aug. 2, the German garrison retiring by the railway to Tabora, 200 m. east. Other Belgian detachments now crossed Tanganyika S. of Ujiji, and these and Olsen's brigade advanced of Tabora.

Molitor's brigade, whose objective was also Tabora, had the cooperation of a British column under Brig.-Gen. Sir Charles Crewe, a South African soldier, who was on Gen. Smuts's staff. With a force of about 1,800 men Crewe captured Mwanza, the German port on the southern shores of Victoria Nyansa, on July 14. Thereafter the Molitor brigade marched W. and Crewe's column E. of the road leading from Mwanza to Tabora. Both forces suffered from transport difficulties, excessive heat and lack of water, and both had to fight several stiff actions. Tabora was the most important and the largest place in the interior of German East Africa. The Arabs had a large colony; there were Greek, Genoese and Indian traders and representatives of many African tribes. To lose the place would be a severe blow to the

The Germans had sent the enemy civilians they interned and also many of their soldier captives to Tabora. The British Europeans interned numbered over 200, a large proportion being missionaries, women as well as men. All the Europeans—there were Belgians, Italians, French and Russians as well as British—were harshly treated, but the British were subjected to calculated indignities, with the object of lowering British prestige in the eyes of the natives. The Indian and African prisoners of war were treated with open brutality. One Brandt, commandant of Tabora, was directly responsible, but his action appears to have been approved by Dr. Schnee, and it was not till the Belgians were approaching Tabora that Schnee ordered better treatment of the prisoners. Von Lettow seems to have had no responsibility for the ill-usage of the prisoners. There was, however, first-hand evidence that at the prisoners' camp at Chiwata he took no steps to put an end to the inhumanity with which the Indian prisoners were treated.

<sup>1</sup> The Belgians also launched a small vessel on Tanganyika.

German in Arab and African eyes, but though they fought strong delaying actions with Olsen's brigade W. and Molitor's brigade N. of Tabora they had no intention of holding out to the last, and in preparation for departure Gen. Wabbe employed British, Indian and African prisoners in building a road towards Mahenge and established food depôts along it. On Sept. 18 Wabbe evacuated Tabora, leaving behind about 150 white (German) soldiers, some sick, some simply war-weary, a number of civilians (among them Frau Schmeel), many prisoners of war and considerable military stores. The Belgians occupied the town the next day. Sir Charles Crewe's column, which, it was hoped, would have reached the railway line E. of Tabora before the Germans had time to get away, only struck the line a week later. Shortly afterwards the column was broken up and Sir Charles Crewe returned to South Africa. He had, said Gen. Smuts, "rendered very useful service." The Wintgens column in its retreat was engaged by a Belgian detachment at Sikonge, 40 m. S. of Tabora. Though Wintgens suffered serious loss he made good his escape. With this action the Belgian campaign of 1916 ended, just at the close of the dry season and at the same time that Smuts suspended his operations against von Lettow. Gen. Tombeur's organization had been thorough and methodical, and Cola Olsen and Molitor had proved capable commanders. The Congo Carrier Corps was disbanded and returned to Uganda.

When the Germans evacuated Tabora the operations conducted by Gen. Northey from the Nyassaland-Rhodesian border had so far developed that some of Northey's columns were

#### Northey's Campaign.

interposed between Tabora and Mahenge. Northey had taken the offensive on May 25 (1916). His fighting force was about 5,000 strong; it was made up of King's African Rifles (1st battalion), South African troops (infantry), Nyasa and Rhodesian volunteers, the Northern Rhodesian Police (natives under European officers), the British South African Police (Europeans), and, later, a battalion raised from the natives of northern Rhodesia. For the supplies of this small fighting force the administrations of northern Rhodesia and Nyassaland were responsible. Some idea of the effort required is seen from the fact that up to July 1917, out of a total native population of scarcely 2,000,000 in the two districts named, 395,000 were employed as carriers. Much of the supplies had to be carried, in canoe or on foot, fully 600 miles.

Northey's forces were in two main columns: a Nyassaland column under Maj. (temporary Lt.-Col.) G. M. P. Hawthorn, and a Rhodesian column under Lt.-Col. R. E. Murray. A third column under Lt.-Col. T. A. Rodgers cooperated with Col. Murray. The advance was along the 200 m. front between lakes Nyasa and Tanganyika; there was a great deal of detached fighting, some German commanders, in von Lettow's opinion, too easily surrendering. Bismarckburg, the German port at the S. end of Tanganyika, was occupied by Col. Murray on June 8. Northey's main thrust was along the highroad which led from the Nyasa frontier by Nen Langenburg and Iringa to Kilosa on the Central (Tanganyika) railway—the road crossing the Tabora-Mahenge route. In an action on July 24 at Malangali Northey defeated the German force which sought to bar his progress, and on Aug. 10 the British seized Lupembe, a place 100 m. W.S.W. of Mahenge. On Aug. 29 Iringa was occupied. Exactly a week earlier Van Deventer had taken Kilosa, 120 m. N.E. of Iringa. Northey could have reached Iringa much earlier, but on Gen. Smuts's advice he "slowed down."

When von Lettow had been forced to take to the lower Rufiji district, it was decided that a joint effort should be made by Van Deventer and Northey to deal with the enemy in the Mahenge district. But before that operation could be undertaken—Van Deventer's men were nearly spent after over six months' fighting, marching, privations and illness—Northey had to meet the troops of Gen. Wabbe coming from Tabora. The Germans were in three columns, an eastern under Maj. von Langern, a centre column under Wintgens, and a western under Lt. Huebener. Wabbe was with the centre column. The western column lost touch with the others, which acted in close cooperation. Northey's columns near Iringa were much outnumbered. Al-

though Col. Rodgers with a small body of South Africans made an effort to hold up the enemy on the night of Oct. 21 1916 the larger portion of Gen. Wabbe's troops broke through the British lines. An attack made by Maj. Kraut the same day on Mkipira, in the Lupembe region, was regarded by the British as evidence of his knowledge of Wabbe's movements; von Lettow states that this was not the case. The attack on Mkipira ended in a severe reverse to the Germans, but sharp fighting with Wintgens' column continued in the Lupembe area till the middle of Nov., by which time the Germans had occupied a chain of posts covering Mahenge, extending over 200 m., and facing Van Deventer's and Northey's troops. Huebener's column was still W. of Northey's lines, in the neighbourhood of Lake Rukwa. This was a region where there were neither British nor Belgian troops, and for weeks the British had been doubtful even of the existence of this column. It was eventually tracked down at Ilende by Col. Hawthorn and bluffed into surrendering. It numbered 54 Europeans and 249 askaris, and the booty included a 4-in. howitzer (one of the guns from the "Mafia").

The combined attack by Van Deventer and Northey against the Mahenge force was at length begun, on Dec. 24. The operation failed, though one of Northey's columns compelled the surrender of Maj. von Grawert and his detachment of 286 fighting men, including 39 Europeans. The main engagement was fought by Van Deventer's force—South African infantry and mounted men. The fight was at Muhanga, 70 m. N.W. of Mahenge, it began on Christmas Day and continued till Dec. 28. The Germans were attacked front and rear, but, as Gen. Smuts was "eventually escaped through the dense brush and forest into cover of darkness and eluded pursuit." The rains had begun early in Jan. (1917) the operations had to be abandoned. Gen. Wabbe had now under him in the Mahenge area 6,000 or more soldiers, of whom at least 2,000 were Europeans, with a large following of carriers, and he found some difficulty in feeding them all. To relieve the pressure he directed Kraut and Wintgens to take detachments S. towards the Portuguese frontier, and Kraut, crossing Northey's lines, reached the Rovuma, where supplies were found. Wintgens had separated from him and turned N.W. (see below). All this time communications between Wabbe and von Lettow were slow and irregular.

Since the abandonment of the pursuit of von Lettow at the end of Sept. (1916) Gen. Smuts had been engaged in reorganizing his army and in shortening lines of communication by making Dar-es-Salaam his base. He evacuated 22,000 to 25,000 white troops (South Africans), their place being taken by the Nigerian Brigade (under Maj.-Gen. F. H. Cunliffe) and new battalions of the King's African Rifles. The German ports S. of Dar-es-Salaam had been occupied by the navy in preparation for a new offensive. Of these ports the chief were Kilwa and Lindi, Kilwa being the nearest to Dar-es-Salaam. A considerable force had been concentrated at Kilwa by mid-Nov., when Gen. Hopkins took over command in that area. On Jan. 1 1917, in conjunction with Van Deventer's and Northey's operations in the Mahenge region, Gen. Smuts opened a new offensive against von Lettow, Hopkins cooperating from Kilwa in the rear of the Germans. Smuts tried an enveloping movement on the Mgeta river, but again, after very stout fighting, the enemy got away; they were followed up towards the Rufiji and engaged on Jan. 4 at Beho-Beho, in which fight F. C. Selous was killed at the head of his company of 25th Fusiliers. Though severely handled the Germans "again slipped past" and crossed the Rufiji at Kibambwe. The operations continued and were proceeding favourably to the British until the rains turned much of the valley of the Rufiji into a vast lake; and in that region, uncomfortably enough, von Lettow was able to maintain himself.

In the middle of these Jan. operations Gen. Smuts gave up the command. At the request of Gen. Botha he went to England to become a member of the Imperial War Cabinet. Having handed over the command in East Africa to Gen. Hopkins Smuts sailed from Dar-es-Salaam on Jan. 20 for London. Gen. Van Deventer left East Africa at the same time, returning to South Africa.

British Forces re-organized Chapter in the Campaign.

In consequence of the heavy rains Gen. Hoskins had to suspend operations on a large scale, though by the end of Feb. the N. bank of the Rufiji was cleared of the Germans. Some idea of the difficulties caused by the rains may be gathered from the fact that in this area "patrol work had to be carried out for some time in canoes, and the men found themselves making fast to the roofs of houses which had lately formed their quarters" (Gen. Hoskins's despatch). Sickness among the European and South African units was so great as to necessitate their withdrawal. As many as possible were sent to South Africa to recuperate, being recalled in May, when the dry weather permitted the offensive to be resumed. Meantime Gen. Hoskins utilized the period of the rains to undertake a thorough reorganization of his forces. The training of new battalions of the King's African Rifles was pushed on rapidly, and special attention was devoted to the improvement of communications. The difficulties of transport were very great; owing to the tsetse fly animal transport was no longer possible; both carriers and light mechanical transport, essential for a forward movement, were deficient. Gen. Hoskins by energetic measures largely overcame these difficulties.

To an extent hard to realize, the operations—of the Germans equally with the British and Belgians—depended on the number, organization and distribution of native carriers. Complete statistics are lacking, but on the British side alone, first to last, well over 500,000 carriers were employed. Those with the main forces were recruited from British East Africa (Kenya Colony) and Uganda; in both of which countries a Compulsory Service Act was put in force in March 1917. Uganda, which also found a large number of carriers for the Belgian troops, up to the end of 1917 had furnished a total of 178,000 porters (besides 10,000 men for the King's African Rifles). A still larger number was recruited in British East Africa; a fair number of carriers were also recruited in German East Africa itself. Gen. Northey, as already stated, obtained his carriers from Northern Rhodesia and Nyasaland. Many carriers were used in the first line, that is they took ammunition, water, etc., right up to the fighting men, and casualties in action amongst these carriers were numerous.

There was also serious wastage among the carriers from sickness and privations, especially among the men obtained from Uganda and British East Africa. This arose mainly from the difficulty in supplying them with their accustomed food. Tribes, like the majority of those in the Uganda Protectorate, whose staple food consists of bananas, sweet potatoes and beans, suffered from intestinal disease when placed on a grain diet. For example out of 3,576 carriers from Uganda employed in the coast region of British East Africa between Aug. 1914 and March 1915 only 2,050 returned. Sufficient care was not always taken by officers in charge to procure suitable rations. But these cases were exceptional, and the African Native Medical Corps, 1,000 strong, raised in 1917 (recruited mainly from the senior high-school boys in Buganda), did much to improve the health of the carriers. In 1918 the carriers in hospital numbered 7%. The West African troops had their own Carrier Corps, raised voluntarily in Nigeria, the Gold Coast and Sierra Leone. The South African troops also brought their own carriers and labour contingents, a total of 60,300 men being sent from the Cape.

Before the weather had improved sufficiently to permit the offensive to be renewed Gen. Hoskins was appointed to command a division in Palestine. Gen. Van Deventer returned from South Africa and took over the command on May 29 1917. The position of the Germans at this time was briefly this: von Lettow with his main force was at the Matunda river, with patrols and detachments pushed close to S. of Kilwa. Maj. Gen. Wahle had recently been transferred from Mahenge to command in the Lindi area, succeeding Capt. Looff. At Mahenge Capt. Tafel had taken over control. There were smaller German detachments between Kilwa and Lindi and near the Rovuma. There was indirect if not direct communication between all the German forces. Nowhere, as throughout the campaign, was there any continuous front. The columns under Northey contained the Mahenge force on the

Si and W., and Van Deventer had at first another column watching Tafel from the N.W. The rest of Van Deventer's force was to be engaged against von Lettow. That von Lettow might in the last resort retire into Portuguese territory had been foreseen; he had in fact contemplated that course ever since in Sept. 1916 he had been forced out of the Uluguru mountains. And German columns had already raided deep into Portuguese East Africa, bringing back much loot and reports of a land flowing with milk and honey.<sup>1</sup>

For his main operations Van Deventer had the choice of an advance either from Kilwa or Lindi. An advance from Lindi (which is situated on the estuary of the Lukuledi) appears to have had the prospect of the best results, as by pushing forces up the valley of the Lukuledi and joining hands with Northey's column E. of Nyasa (the escape of von Lettow into Portuguese territory might have been prevented. But Lindi harbour was poor, that at Kilwa was good, and the main body of the Germans was concentrated near it. Van Deventer's formula was to "find the enemy and hit him hard," and he decided to attack on the Kilwa side. The Kilwa force had been under Gen. Hannington, but Hannington was then seriously ill and Gen. Beves was in temporary command. The advance began on July 5, in the direction of Liwale, it being hoped to force von Lettow to disclose his intended line of retreat. Three columns were formed, the forces engaged including South African infantry, King's African Rifles, the 23rd Punjab and two mountain batteries. After some sharp fighting the Germans fell back to Naruhombe, where an engagement was fought on July 19. The fighting was very severe; the Germans delivered several well-sustained counter-attacks and the issue appeared doubtful. The fight showed that "the enemy's capacity for resistance had not in any way been weakened by the rainy season; and that the moral and training of his troops remained high" (Van Deventer).

After the fight at Naruhombe the Germans, who were under Capt. von Liebermann, retreated south. Von Lettow regarded the action as an opportunity missed by von Liebermann and as further proof of the immense difficulty of carrying out successfully in the bush operations in which several columns are engaged. But Beves's offensive was spent, and his troops suffered heavily from sickness. It was not until mid-Sept. that a new Kilwa force was ready to take the field. In the meantime preparations had been made for the advance from Lindi. In Aug. Brig.-Gen. E. de C. O'Grady, a great fighting soldier, had driven the Germans from the estuary of the Lukuledi, and provided elbow room for a further advance. He also foiled an attempt made by von Lettow in person to surprise his force.

When in Sept. Van Deventer was at length in a position to begin the main advance Gen. Beves had been transferred to the Lindi command and Gen. Hannington had resumed command at Kilwa. The Nigerian Brigade had been at Kilwa since Aug., and Hannington had also three new battalions from India, including the 25th cavalry. It was planned that the Kilwa force should sweep S. and the Lindi force W. so as to enclose von Lettow and prevent his breaking W. and consolidating with the Mahenge force. This period of the main advance, up to the end of

Van Deventer's Campaign in the South-East.

<sup>1</sup> Here may be mentioned the most remarkable raid of the whole campaign. When early in March 1917 Wintgens parted from Maj. Kraut he took his detachment N.W. to Lake Rukwa, where he was engaged by, but escaped from, one of Northey's columns. He then continued N. towards Tabora, but falling ill with typhus surrendered to the Belgians (May 23). A Lt. Naumann then took command of Wintgens' men. Constantly pursued, he reached almost to the borders of British East Africa, then doubled back, losing men in several encounters, redoubled N. and finally was compelled to surrender with the remnant of his command—146 soldiers out of 600—at the beginning of Oct. (1917). A regiment, the 10th South African Horse, had been specially raised to help in tracking him down. "Such a raid," wrote Van Deventer, "could perhaps only have been carried out in a country like German East Africa, where the bush is often so thick that two considerable forces may pass within a mile, unaware of each other's presence; and where a ruthless leader of a small force can nearly always live on the country; and avoid pursuit."

Nov.); witnessed the hardest fighting of the whole campaign in East Africa. Notwithstanding by Hannington's columns von Lettow was compelled to fall back to the Lukuledi valley, the chief line of retreat being towards Nyango, a place 40 m. S.W. of Lindi, towards which Beves was pressing back Wahle's detachments. Early in Oct. Hannington detached the Nigerian Brigade (with which was the Gambia Company) to march to Nyango and join the Lindi force. Meanwhile other columns of the Kiwa force, including cavalry, were marching S., but further W. towards the mission stations of Lukuledi and Massisi. At those places, and at Chitwa, S. of the Lukuledi river, were most of the German supplies.

The Nigerian Brigade, after a fine march of 80 m., reached its destination on Oct. 15. On that day two columns of Beves's

#### The Fight at Mahiwa.

force under Gen. O'Grady and Col. Tyler respectively had driven back Wahle's main body to Nyango and Mahiwa (the latter about two m. from Nyango).

The Nigerians were to cooperate in cutting off Wahle's retreat (preparatory to the pursuit of von Lettow), and were in action early on the 15th. This was the beginning of a four days' battle, the most stubborn and most costly of the whole campaign. Von Lettow with four companies had gone to the help of Wahle, and attacks were met by counter-attacks; the Nigerians at Mahiwa being driven back and very hard pressed. Nyango the Germans abandoned on the 16th, only to take up stronger positions on a ridge two m. S. on the farther side of a river bed. These positions the British in vain assailed; they were in turn counter-attacked on the 17th and again on the 18th and compelled to fall back to the river bed, the enemy pressure continuing until after dark. Gen. Beves gave orders that the attack was to be resumed on the 19th. This order was cancelled by Gen. Van Deventer, and on the same day the command of the Lindi force was transferred to Gen. Cunliffe. On that day the Germans retired to the positions they had taken up on the 16th. The battle was over. Out of a total strength of 4,000 infantry engaged the British had 2,700 casualties, of which 528 were in the Nigerian Brigade. The 25th <sup>of</sup> <sup>the</sup> <sup>British</sup> <sup>Infantry</sup>, reduced to a remnant in previous fighting, had 70 casualties out of 120 men who went into action. Von Lettow says that the German force was "some 1,500 men" and their casualties 500. This did not include all Wahle's casualties in the retreat to Mahiwa, for on Oct. 15-8 the British captured in all 100 Europeans and 677 askaris. The total German force engaged was not fewer than 2,800. Von Lettow describes this fight as, next to Tanga, the most serious defeat suffered by the British, and says he adapted his tactics to those of Gen. Beves, who "threw his men into action regardless of loss of life and did not hesitate to try for a success . . . by repeated frontal attacks." He (von Lettow) abandoned the idea of "an annihilating pursuit" as he learned that the enemy columns in his rear were threatening the Lukuledi mission station. He hastened to its relief and began the process of concentrating his forces to the Chiwata region: The Mahiwa-Nyango battle gave him this advantage—it was 10 days before Gen. Cunliffe was able to resume the offensive. On Oct. 24 von Lettow had a conference with Dr. Schnee, who appears to have urged that the end had come, but, writes von Lettow, "I firmly stated my opinion that . . . the war could and must be carried on."

Meanwhile Tafel's force had been driven from the Mahenge plateau with the help of troops furnished by the Belgians, whose cooperation had been sought. While columns of Northey's force, under Cols. Hawthorn and Fair, pressed the enemy hard from the S. and S.W., the Belgians struck at Mahenge from the north. The main Belgian column, under Maj. Battile, left the Central railway on Aug. 15, and made good progress through very difficult country. The Germans put up the usual strong rear-guard delaying actions, but when the Belgians attacked (Oct. 8) the last defence of Mahenge, Tafel ordered a general retreat. His losses had been heavy and many of his askaris deserted. Both Hawthorn and Fair were drawing near, but Tafel succeeded in outdistancing his pursuers, whose long lines of transport had reached breaking point. Tafel chose the only route open to him—

that leading S.E. in the direction of von Lettow. On Nov. 16 he broke through two weak detachments of Northey's force which gallantly endeavoured to bar his progress. A Belgian column, which had been sent round via Kiwa to Liwale, arrived only in time to engage Tafel's rear-guard. This was the end of the Belgian effort, and their troops shortly afterwards returned to the Congo. The pursuit of Tafel was taken over by the Kiwa force and his attempt to join von Lettow was frustrated.

At this time, mid-Nov., von Lettow's position was critical. The Lindi force had resumed its offensive on Nov. 6 and had joined hands with the Kiwa force on Nov. 12. Von Lettow had concentrated all his men near Chiwata, but to remain there meant certain disaster. So leaving only a small body at Chiwata to put up a delaying action—the place was taken by Gen. O'Grady on Nov. 14—he retreated eastward, i.e. towards the coast, along the broken edge of the Mkwandi Plateau. He was pursued without pause and constantly engaged, suffering losses every day, was in a foodless region and had lost nearly all his stores. On Nov. 17 von Lettow took what he calls a fateful decision. It was to abandon all idea of fixed bases; reduce his force—half-starved and very short of ammunition, break off fighting and get away to some district where food was to be found. At a place called Nambindinga he lost some hundreds of Europeans (many of whom, he states, were not unwilling to lay down their arms) and 600 askaris, and with the rest again eluded his pursuers by taking S.E. "by an unsuspected path." While the British columns were re-forming to pick up his trail he marched rapidly S.W., having determined to cross the Rovuma near its confluence with the Lujeza, where was the Portuguese fort of Ngomano. At Nwali he shed more of his troops, and his force was now reduced to approximately 300 Europeans, 1,800 askaris and 3,000 bechen and other natives, including women and children. He marched along the Rovuma to the selected crossing place, and on the night of Nov. 25-6 he crossed the river into Portuguese territory. Gen. Wahle, Maj. Kraut and other tried leaders were with him and also Dr. Schnee. Two attempts to overtake him "failed by a few hours at both places, in spite of hard marching." So wrote Col. G. M. Orr, commander of one of the pursuing columns.

For a day or two Tafel and von Lettow had been near one another; Tafel had reached the Rovuma, but not finding von Lettow turned back. Running into an Indian patrol Tafel again tried to turn south. But his force was foodless and hopeless. On Nov. 27 a party of 37 Germans, 178 askaris and 1,100 followers gave themselves up to the British, and the next day, Nov. 28 1917, Tafel himself surrendered unconditionally with 29 officers, 94 other Europeans, over 1,200 askaris and some 2,700 other natives.<sup>1</sup>

Not a single German combatant was left in German East Africa, and the conquest of the Protectorate was complete. At the time of his flight into Portuguese territory von Lettow states that he received a second summons to surrender. But he was no more ready to surrender to Van Deventer than he had been to Smuts; moreover, he considered his position satisfactory inasmuch as he could still contain a large enemy force.

The failure of the Portuguese to prevent von Lettow from crossing the Rovuma, or in accounting for him when he had crossed that river, was not due to lack of effort on the part of the Lisbon Government. During 1916-7 they had sent over 2,000 white troops to Mozambique, and between May and July 1916 another force of 4,600 strong was sent from Lisbon. Part of this force had occupied Nwali (Oct. 1916), but had been forced to evacuate it a month later.<sup>2</sup> In 1917 Portugal sent 2,776 more men from Lisbon, and had strengthened the posts along the Rovuma, including that at Ngomano. But the Portuguese white troops

<sup>1</sup> A party of six Europeans and 20 askaris under Capt. Otto broke away from Tafel the night before his surrender and eventually joined von Lettow.

<sup>2</sup> Urgent instructions were sent by the Lisbon Cabinet to the Portuguese commander, Gen. Gil, to cooperate with Gen. Smuts. The original idea was that Gen. Gil should march on Lindi.

lacked experience; there were not sufficient trained native soldiers and the military posts were widely scattered. Nor was any one post equal to a successful defence against the 2,000 and more veterans von Lettow had with him. Ngomano was attacked, and it surrendered after a gallant resistance in which some 200 casualties were suffered, including the commanding officer, Maj. Pinto. Its loot gave the Germans just what they lacked—food, ammunition, rifles, machine-guns and clothing. The Nigerians and the 25th Cavalry being in pursuit von Lettow then marched up the Lujenda valley. He had no difficulty in keeping ahead of the enemy, and the rainy season having set in the Nigerians and 25th Cavalry were recalled in the third week in Jan. (1918) and the Germans had a short breathing space.

Gen. Van Deventer now sent home all his white and Indian troops, and the Nigerian Brigade also. Except for the Gold Coast Regiment (which was not sent back till Aug.) the 1918 operations were carried out almost entirely by natives—the King's African Rifles. There were, however, a considerable number of Europeans among the Portuguese forces, which were put under the supreme command of Van Deventer.

Given the character and extent of the country into which the Germans had entered, the known determination of von Lettow to continue the struggle and the proven difficulty of bringing him to a decisive action, "the 1918 campaign," said Van Deventer, "had perforce to be one of virtual extermination." Wide covering movements were undertaken. Gen. Northey sent columns from the E. and S. shores of Lake Nyasa, while the Gold Coast Regiment advanced W from Port Amelia (a harbour midway between the Rovuma and Mozambique). This Port Amelia column was later strengthened and came under command of Brig.-Gen. Edwards. Between Feb. and the middle of May the Germans were engaged at several points from both sides, mainly in the central region between the Lujenda and Msalu rivers. Von Lettow then marched S. to the Lurio river, 200 m. from the point where he had left German territory, with no enemy in front of him except isolated Portuguese posts, from which he obtained more valuable supplies. He was pursued from the N., and an Anglo-Portuguese column started N.W. from Mozambique (to which port Gen. Edwards removed his base) to overtake him. But von Lettow, marching very quickly S., captured Ilie, and in June reached the coastal region near Quilimane (Kilimane), where he ravaged many rich *prazas*. In this month Gen. Northey left, having been appointed governor of British East Africa and Col. (Brig.-Gen.) Hawthorn took his place. On July 1 von Lettow attacked a mixed Portuguese and British force at Nhamacurra, 25 m. from Quilimane, and after three days' fighting captured the place and inflicted very severe loss on the defenders. The approach of strong British columns then compelled von Lettow to retire. He marched parallel to the coast, in the Mozambique direction. He established himself at a place called Chalaus, but when in mid-Aug. British columns closed in upon it, it was to find the camp evacuated. Von Lettow had turned N.W. again, one of his ideas at this time being to raid the Blantyre district of Nyasaland. On Aug. 30 and 31 he was engaged by part of Hawthorn's force at Lioma, E. of Lake Shirwa, and suffered severely. "It was hoped that the enemy might have been captured, but the rugged country and the thick bush made operations very difficult, and he finally broke away to the northward."

Save that he could not replace his casualties (except to some extent by turning bearers into askaris) von Lettow held the advantage in this campaign in northern Portuguese East Africa. It was nearly as large as France, most of it was fertile, and the natives, richly rewarded with booty from captured posts, were friendly and useful. If hustled from one area there were others to which he could move. He was tied to no base and was an ideal guerilla leader. He had now, end of Aug., to decide his future course; he came to the conclusion that an attempt to invade British Nyasaland was too risky, as there the British communications were good. It was easier to go north. To re-enter German East Africa would be a complete surprise to the enemy, who would imagine he was making for the Tabora region (where

most of his askaris came from) and take precautions accordingly. This would give him an opportunity of turning in another direction, and keep his force in being. His casualties at Lioma had numbered 95, and he had lost stores, baggage and ammunition. By Sept. 1 his total strength had been reduced to 176 Europeans and 1,487 askaris. He suffered further loss in another encounter on Sept. 6, after which date he got clear of his pursuers. Gen. Hawthorn had sent troops by steamer up Lake Nyasa, which should have reached the N. end of the lake before von Lettow could get there; the steamers broke down, and when on Sept. 28 the Germans again reached the Rovuma they were able to overcome the weak posts stationed there. Avoiding places held in strength by the British, and keeping ahead of the columns now in hot pursuit, von Lettow passed round the N. corner of Lake Nyasa, losing many carriers by desertion but recruiting a few askaris. He stayed at Ubena some days and then (Oct. 17) set out for Rhodesia. (At Ubena Gen. Wahle and two other Europeans, sick or wounded, were left behind.) On Nov. 1 von Lettow attacked Fife; just within the Northern Rhodesian border, hoping to capture its stores, but it was too strongly held, so the Germans turned S.W., making for Kasama, von Lettow now having some idea of penetrating into Belgian Congo. Kasama was taken on Nov. 9, but British columns were in its immediate neighbourhood and there were several patrol encounters. Necessity urged von Lettow onward. On Nov. 13 he was reconnoitring a crossing of the Chambesi (the eastern head stream of the Congo) when an English motor-cyclist arrived with a message from Gen. Van Deventer announcing the conclusion of the Armistice. Von Lettow notified his acceptance of the Armistice on Nov. 14; the formal surrender was made to Gen. Edwards at Abercorn on Nov. 23. The force which surrendered numbered 30 officers and 125 other Europeans, 1,165 askaris, and 2,891 other natives, among them 819 women, with one small field gun, 24 machine-guns and 14 Lewis guns. Those who surrendered included Dr. Schnee and Maj. Kraut.

The troops employed by the Allies in East Africa included 52,339 sent from India (among them 5,403 British) and 43,477 South African whites. Other white troops employed (East African and Nyasaland settlers, Rhodesian volunteers and the 25th Fusiliers) numbered about 3,000, the African troops (King's African Rifles, Nigerians, Gold Coast Regiment, Gambia Company, Cape Corps—1,600 strong—and West Indians) about 15,000; an approximate total of 114,000, not reckoning Belgian native troops—about 12,000 in all—the Portuguese and the naval force engaged. The greatest number in the field at any one time, May to Sept. 1916, was about 55,000; the lowest number, in 1918, was some 10,000, all African, save the administrative services. The total British and Indian casualties was officially returned at 17,823; of these 2,762 were among the South African Forces. These figures are exclusive of casualties among carriers and of deaths and invaliding through sickness which among the South Africans alone exceeded 12,000.

The cost of the campaign to Great Britain, inclusive of Indian and South African expenditure and that of the local protectorates to March 1919, was officially estimated at £72,000,000.

**AUTHORITIES.**—British.—The despatches of Generals Smuts, Hoskins, Van Deventer, Northey, of the High Commissioner for South Africa (Lord Buxton), the Governor of Nyasaland (Sir George Smith) and of Adml. Charlton, published in the *London Gazette*, cover the operations, except the period up to March 1916, on the British East Africa frontier and the early naval operations, concerning which no despatches were issued. *The Times' History of the War*, chaps. 155, 183, 206 and 276, covers the whole campaign. Brig.-Gen. J. H. V. Crowe, *Gen. Smuts' Campaign in East Africa* (1918), has an introduction by Gen. Smuts and an account of the blockade runners. For the German treatment of prisoners, etc., see the White Paper, Cd. 8689 (1917); E. F. Spanton, *In German Goals* (1917), and J. H. Briggs, *In the East Africa War Zone* (1918). For particular units see A. Buchanan, *Three Years of War in East Africa* (1919), chiefly about the 25th Fusiliers; Sir Hugh Clifford, *The Gold Coast Regt. in the East African Campaign* (1920); W. D. Downes, *With the Nigerians in East Africa* (1919); G. M. Orr, *The Indian Army in East Africa*; *Jnl. U.S. Inst. India* (1919).

von  
Lettow's  
Surrender.

Troops  
Employed  
by the  
Allies.



German.—Gen. von Lettow-Vorbeck, *Reminiscences of East Africa* (English trans. 1920); Dr. Ludwig Deppe, *Mit Lettow-Vorbeck durch Afrika* (1919); Dr. H. Schnee, *Deutsch Ost-Afrika im Weltkrieg* (1919).

Belgian.—P. Daye, *Les Conquêtes africaines des Belges* (1918). (F. R. C.)

**EASTERN EUROPEAN FRONT CAMPAIGNS.**—Under this heading comes the general story of the campaigns of the World War which were fought between 1914 and 1917 on the front between the Baltic and the Black Sea. Till the summer of 1916, Rumania was neutral, and the theatre of war was limited on the S. by the northern extremity of that country. Thereafter, till the conclusion of the peace of Brest, the Russian and Rumanian fronts became one.

The story falls into three main parts, of which the first is considerably the most important. These are—the open-warfare, free-manceuvre campaigns from the outbreak of war till the establishment of a continuous trench line and the setting-in of trench-warfare conditions, along the whole front in Oct. 1915; the trench-warfare operations on the Russian front from that date to the peace of Brest; and the Rumanian campaigns of 1916 and 1917. The events of 1918 belong rather to the story of the Russian civil wars than to that of the World War, and may be summarized for the present purpose in two clauses—the occupation of the Ukraine, for its economic exploitation, by German and Austrian forces, and the maintenance of a cordon, requiring large numbers of troops, along the frontier of Bolshevik Russia to provide against the contingency of a new eastern front being built up by the Entente and the Soviet Government, or by either singly. As an active element in the operations of the World War, the eastern front closes its history with the battle of Riga in the autumn of 1917, and this event, therefore, is taken as the limit of the present article.

#### I. THE THEATRE OF WAR

The operative contrast between the eastern and the western theatres of war lies less in the greater distances and areas of the former than in the fact that there Nature's handiwork has not been greatly modified by man's, whereas in France and Belgium there is an intense network of main roads and railways, and in many parts a great industrial development that has covered the country with factories, mines, tramways and workmen's suburbs. Hence arises a peculiar distinction. Strategically, the western theatre is penetrable everywhere; tactically, it is in many parts so tangled that coherent operations are nearly impossible. In the east, on the contrary, it is strategy that is difficult and tactics that are simple.

The importance of area and distance must not of course be ignored. Without counting Rumanian territory the theatre measures 650 m. x 320 m.—a six weeks' march under peace conditions from flank to flank, and a three weeks' march from front to rear. This and the unfamiliar sound of the place and river names to western ears have tended to make the operations of the eastern front seem more difficult to understand than they really are. In fact, the course of operations was largely dictated by geography, and the map, rightly read, shows the lines of geography to be drawn in bold, strong strokes. And even in point of distance, the E.-W. depth of the theatre is not more than 1½ times the distance covered by the Germans in their 1914 sweep through Belgium and France, and only half that covered by the *Grande Armée* in its march from the Rhine to Austerlitz in 1805. The picture of the operations of 1914-17, therefore, is not too large for comprehension, and the meanings of its parts are usually clear.

The broadest characteristic of the eastern theatre is its division into four well-defined regions. (a) The great central salient of Poland on and W of the middle Vistula. (b) The Pripyat or Rokitno marshes, an area of 240 x 160 m. which, though largely reclaimed in modern times and therefore penetrable to a certain extent for tactical purposes, constitutes an almost insurmountable barrier to strategic movements on a large scale. Lying behind the Polish salient, these marshes, as it were, hollow out its base, leaving on either hand two avenues or corridors:—

(c) the northern, connecting Petrograd and Moscow with both western Poland, and (d) the southern, connecting Kiev and S. Russia with Galicia and S.W. Poland. To the right and left rear of the salient (a) the two corridors (c) and (d) lie exposed on their outer flanks to hostile attack from E. Prussia and Galicia respectively, except in the portions nearer to their eastern entrances where the hostile frontiers curve away to the sea and to Bessarabia. Across the base of both corridors and in rear of the central marshes runs a water barrier consisting of the western Dvina and the Dniester lines, unbroken save for the narrow gap at the watershed traversed by Napoleon in 1812. This waterline marks the eastern limit of the theatre. Its western limits, which espouse the shape of the salient, lie inside the frontiers of Germany and Austria-Hungary and may be taken as the lake region of W. Prussia, the Oder and the Silesian and Carpathian mountains. This limiting line, in contrast to the eastern, has several gaps, of which the most important is that lying between the Silesian and the Carpathian mountains— which is the gate to Vienna, and, owing to the higher cultural development of Germany and Austria, is strategically more penetrable even where geographical obstacles exist.

Across the whole width of the theatre, cutting off the salient from the corridors and the marshes, runs an almost straight barrier of water, constituted by the Vistula and its tributary the San; from the Baltic to beyond Yaroslav, and by the Dniester from the lakes S.W. of Lemberg to the Black Sea. The only gap is between Yaroslav and the lakes of Grodek.

All railways connecting the salient with the interior of Russia, whether they approach by the northern corridor, the marsh or the southern corridor, converge on the Warsaw-Ivangorod portion of this waterline and thence make south-westward for Upper Silesia. Practically all railways from S. Russia to Austria-Hungary, on the contrary, traverse the gap of Grodek-Yaroslav. The only line from Russia to the German Baltic lands enters E. Prussia at Wirballen at the broad entrance of the northern corridor; and similarly, at the other end of the theatre, a line from Bessarabia comes into the Bukovina system at Czernowitz. Apart from these two, the whole length of the northern corridor is traversed by three lines from Dvinsk, Polotsk and Orsha respectively ending at Warsaw and Ivangorod; the central marshes by one from Gomel which at Brest-Litovsk merges with the third of the northern lines; and the southern corridor by two from Kiev and Berdichev respectively which at Kovel become one, ending at Ivangorod. The significance of the various lateral lines connecting these approach lines is best judged by studying the map, and here it is enough to draw attention to (1) the line along the eastern base itself; (2) the line Baltic-Shavlī-Vilna-Minsk with its accessory Vilna-Baranovich-Rovno; (3) the line Kovel-Brest-Litovsk-Oswiec-Lyck-Memel (4) the line Ivangorod-Warsaw-Mlava-Danzig; (5) the line Skiermiewice-Lowic-Wloclawek-Danzig. It should also be noted that, in the salient, no lines exist W. of Lodz and N. of Czenstochowa, and that in the northern corridor about Godno and Augustowo the Prussian and Russian railways carefully avoid contact. Of the road system, it may be said, broadly, that first-class roads are not numerous, and that they group themselves, in the main, on the same axes as the railways. In the area N.W. of Lodz-Czenstochowa, however, roads to some extent mitigate the absence of railways, and about Augustowo the connexion with E. Prussia, which the railways avoid, is, as regards roads, intimate.

Within each of these broad divisions—the salient and the two corridors—other natural features exercised a considerable influence. The chief characteristic of the northern corridor is the practically continuous waterline which defends its flank from attack from E. Prussia. Leaving the Vistula at Novogeorgievsk below Warsaw, this line is formed by the lower Bug, the lower Narew, the Bobr, the lakes of Augustowo and Suwalki, the middle Niemen to Sredniki, the Dubissa, the Vindavski canal which crosses the low Shavlī watershed, and the Venta prolonged by the Vindava to the Baltic. From the Niemen section to Novogeorgievsk almost every important crossing—there are

not many—is protected by permanent fortification of some sort. Its most vulnerable section is that at which the E. Prussian frontier makes contact with Augustowo—Suwalki—Kovno—Grodno. South of this region, on the stretch Rozan—Lomsha, owing to the absence of railways and first-class roads, military operations were never principal, but always dependent upon either those of Suwalki and Augustowo or those astride the Warsaw—Mława—Danzig line. North of Kovno, at the broad entrance to the corridor, it was safe against all but secondary attacks, so long as Kovno held out and kept the attack toward Shavl.

Frontally, of course, the corridor was protected by the Vistula and its fortresses Ivangorod, Warsaw and Modlin or Novo-georgievsk (this last at the origin of the flank barrier just described), and behind this frontal defence were other successive lines—the middle Bug, the middle and upper Narew, the upper Niemen and its feeders, the Villa system—not to mention partial barriers such as the Wicprz. But most of those rear barriers, in particular the Bug, tend in their upper course to turn southward, thus opening to an invader who stands N. of the San a series of successive gates along the inner edge of the corridor, by which penetration is possible to Białystok or even to Baranovichi. Hence the special importance attaching, in the operations of 1914-5, to the lower San sector and the fortress of Brest-Litovsk. The southern corridor, unlike the northern, lies partly on one side of the political frontier and partly on the other. No important natural barrier prevents either an Austrian irruption from the S. as far (roughly) as the line Lublin—Kovel—Sarni, or a Russian irruption through and past Lemberg (Lvov) to the Dniester. As has just been mentioned, the left wing of such an Austrian irruption has the opportunity of seizing the gates of the northern corridor; no reciprocal advantage offers itself to the Russians since the Dniester line is doubled by that of the Carpathians. But, in particular, the fact that the whole Lemberg region is within the Austrian frontier narrowed the corridor normally open to the Russians to a mere strip of country. To protect this from being cut off from behind, the Russians had constructed a triangle of fortresses Rovno—Dubno—Lutsk. At its front end, where it joins the northern corridor and the salient, Ivangorod, Brest-Litovsk, and minor river courses and marshes were relied upon to seal the region of Chelm and Vladimir Volynsk; in effect, a drive by the Austrians into that region if pressed too deep laid open its flanks to counter-attack both from Ivangorod and from Lutsk (Luck).

The geography of the interior of the marsh area needs little description. As above mentioned, much of it is tactically penetrable, but owing to the extreme paucity of communications, as well as to its physical difficulties, it is on the strategic plane essentially an obstacle and not a field of manoeuvre. Its outstanding geographical feature is its river system; the Pripyat itself runs W.—E., but it has numerous N.—S. tributaries notably on the S. side, and these tributaries sometimes form, with tributaries of the Dniester (flowing in the opposite direction), N.—S. waterlines of defence only broken at the watershed (Brody, for example) along which run the communications between Rovno and Lemberg.

In the forefront of the central salient, too, it is the waterlines that are the most important features. The course of the upper Warta; that of the Pillica; the position of Lodz (or rather Lenczyńska) at the divide of the Warta and Bzura systems; the course of the Nida meeting at its mouth the mouth of the Dunajec, one of the several Galician rivers which double the San obstacle; lastly, the upper Vistula itself which forms the southern boundary of the salient—all these were important.

Practically the whole of this region belongs to the W. Russian plain, and has marshy valleys, feeble undulations, and great forests, some of these last still existing in primeval density, others already broken up by man's clearings and settlements. The only hilly mass is the Lysa Góra in the Kielce region of the salient. On the contrary, the Lemberg—Brody—Buczacz portion of the southern corridor, and all country between the San and Dniester and the Carpathians, is almost wholly a country of deep-cut valleys and high plateaux.

The German reëntrant opposed to the Polish salient is geographically similar to, but in point of human development very different from, that region. In Silesia, owing to its industrial character, the network of roads and railways is as dense as in western Europe. Without going west of Posen, no less than three complete lateral or circumferential railways join Upper Silesia to the trans-Vistula railways of E. Prussia. As, in face of these, no Russian lateral exists W. of Lodz it is easy to see how this region, in spite of its want of natural defences, was able to act as a curtain between the two bastions of E. Prussia and Galicia, facilitating quick transfers of the centre of gravity from flank to flank and itself (save at one critical moment) immune from attack because of the difficulty of approach.

Of these two "bastions," E. Prussia is the more important as menacing the whole length of the northern corridor, from front to rear. Whereas the Lemberg region only projects from the San—Dniester barrier, E. Prussia has its whole length at right angles to the Vistula. It is served by so many railways that either end of this length is utilizable for the offensive.

The principal directions which this offensive may take are— from the eastern end of the province towards Shavl, from the same towards Kovno and Grodno, and from Mława towards the Narew and, if and when that obstacle is overcome, on Siedlec or Białystok. We have seen that the first of these is inevitably a secondary or dependent operation. Between the other two the choice was always, for the German Command, difficult. Presuming the Narew forced, or Kovno taken, as the preliminary in either case, the one offensive leads close into the rear of the Warsaw—Ivangorod stronghold, while in the other the corridor is seized far back near its entrance; the choice therefore depended on how deeply the enemy was advanced in the Polish salient or how long the passive front of the "curtain" could be held, or what chance there was of coöperation from the lower San through the Bug "gate," and on other factors which had to be reckoned together on every occasion that an offensive was planned. But these two avenues (Kielce of Warsaw—Mława, and Vilna—Kovno for Grodno—Insterburg) equally serve for Russian offensives, and the defensive characteristics of E. Prussia were nearly if not quite as important as its qualities as an offensive base.

The main feature of military geography in E. Prussia is the chain of the Masurian lakes which, in a sickle from N. to S. and then westward, protects the interior against attack from the E. or the S.E. The tongues of land which separate the lakes represent only a narrow frontage which has actually to be defended, and have the effect also of gathering communications, plentiful in the interior, at a few points of exit. To the S. of the lakes a number of tributaries of the Bobr—Narew system continue the water barrier, as against eastern attack, to the Narew; to the N. of them the river Angrapp presents a similar barrier as far as the Pregel, beyond which river smaller streams continue the line of defence with some gaps to the Niemen. Behind the lakes, the next important N.—S. barrier is the line of the Alle which, rising in the central Masurian lakes, runs to the Pregel at Wehlau, whence from Tapiaw to the Kurische Haff runs the Deime. Other partial barriers to an invader's westward progress exist but are of less importance. Finally there is the German section of the lower Vistula which, intricate at Danzig and fortified at Thorn and Graudenz, still bars access to Germany proper when E. Prussia has been conquered or evacuated.

Thus on the E. this province is singularly well protected. But it is to be noted (1) that the frontier, especially in the northern part, lies well in advance of the barrier, and that a policy of passive defence on the lake line forfeits a not inconsiderable region at the outset; and (2) that both the Insterburg—Johannisburg line and the Alle are turned by attack from the S., by Mława and Soldau, where the westernmost part of the lake system dies away. At the centre of the "sickle," on the other hand, the density of the lakes is highest and they not only afford local protection to this part of the region, but also enable the defending army to shift its weight from E. to S.W. and vice

versa without much fear of flank attack in doing so; while, on the Russian side, the paucity of communications in the foreground of these central lakes seriously impedes liaison between the northern or Gumbinnen and the south-western or Soldau groups of the invaders. Such shifts of the centre of gravity are, moreover, facilitated by the dense railway system lying behind the lakes. The frontier railway, which runs from Thorn, by Soldau, Johannisburg and Lyck (junction of the Russian Białystok-Brest-Litovsk transversal), to Tilsit and Memel, lies outside all defensive barriers. But inside the barriers are some three other transversals, one being the Thorn-Insterburg-Wirballen section of the Benlin-Petrograd main line, and the others parts of a well-developed provincial system.

The military-geographical characteristics of the Lemberg region, the other potentially offensive base lying outside the Vistula-San-Dniester barrier, are less sharply marked and their influence is not so definite. Offensive possibilities lie in the direction of (a) Bessarabia, (b) Kiev, (c) Kovel, (d) the inner edge of the northern corridor, towards Brest-Litovsk. Of these, as in the case of E. Prussia, (a) is eccentric, except as a secondary element of (b); and (c) centres on a region which is ill-developed in communications, and therefore operations there are subsidiary to those on either flank. The important alternatives are therefore, speaking broadly, (b) and (d). In (b) Dubno and Rovno play the same rôle as Kovno in the N., and the results to be expected from a successful operation of this character are similar to, but smaller in scale than, the corresponding enterprise on the Niemen. (d) The operation, twice carried out and several times contemplated, offered many results and many risks, and its usefulness varied according to a number of factors like that of the corresponding operation from the N., with which, in fact, it was logically combined.

Defensively, the conditions of the Lemberg region were similar in some respects to those of E. Prussia. Waterlines opposed invasion from the E., while from the N. Lemberg was open. But the real obstacle value of the E. Galician watercourses,—Gnila Lipa, Złota Lipa, Strypa, etc.,—whose names were to become historic, is small, and, though N. of the Styry system and the uppermost streams of the Bug (Styr) have wide marshy valleys and are serious barriers, the watershed itself (Dubno-Brodz-Lemberg) is an open gate both for road and rail approach to the Galician capital.

The railway system of the Galicia theatre, though far inferior to that of Silesia and Prussia, included two complete laterals N. of the Carpathians, and at least one S. of them. From the interior of Hungary and Moravia, over the Carpathians, to the San-Dniester barrier there were eight approach railways between Teschen in the W. and Czernowitz in the E., and four of these pass the barrier at or near the Grodek gap, converging on Lemberg and Rava Ruska. In the latter region itself the railways lie chiefly radially from Lemberg. It is to be noted that on the whole front N. of Lemberg the Russian frontier region is destitute of approach railways.

Finally, the Carpathians (of which Galicia to the Saa, to Lemberg and to the Dniester, is simply a glacis) are not as the sea is to E. Prussia, a definitive barrier, but rather a wall with many gates for the passage of an invader into Hungary and Austria. The mountains themselves are rather Vosgian than Alpine, and their main passes are low enough to be practicable for railways. At the W. and E. ends, the mountains broaden out into the Tatra and massifs, but in the centre the mountain zone is at its narrowest, and it is exactly in front of this that the Grodek gap breaks the forward barrier and allows these railway approach lines to make for the Hungarian plain. West of the Tatra massif, the Troppau gap opens Moravia to an invader who has mastered Upper Silesia. (C. F. A.)

## II. THE CAMPAIGNS OF 1914

*The Russian Plan of Campaign.*—Two characteristics of the Russian Army were admitted on both sides as axiomatic, the relative slowness with which its total forces could be brought to bear and the numerically overpowering superiority of those

forces when assembled and ready. Both these were summed up in the popular phrase of 1914, which likened the Russian Army to a steam roller. The axioms were not, however, independent. Only by waiting could the overpowering strength be realized, and by temporarily forgoing this numerical advantage, it was possible for the Russians to act with partial forces and provisional objectives, almost if not quite as promptly as the armies of the Central Powers. Instead, therefore, of the usual stages of *couverture* and full-power action there would be, or might be, three—*couverture*, rapid partial action, and delayed full-power action—and the application of the geographical factors to strategy varied accordingly.

In all alternatives, the inclusion of the central salient, either in the *couverture* system or in the deployment for the main action, was impossible. In other words, it was militarily evacuated from the outset. In the alternative of delayed full-power action, the *couverture* would guard the outer flanks of the two corridors and the Warsaw-Ivangorod-Lutsk front, while the main masses assembled further back. Flank-guard groups would prolong the defence of the corridors respectively in the Szavli region and to the S.E. of Dubno and Rovno. The line of detachment for the main bodies would be, substantially, Kovno-Grodno-Białystok-Brest, and (for the Southern armies) points behind Rovno. But the abandonment of so large a portion of Poland would only be necessary in the case of Germany's employing the major portion of her forces in the east. In that case, especially if it arose in winter, it was calculated that the Russian forces on the *couverture* line would have to retire fighting, giving up Warsaw and possibly Ivangorod, but holding firmly at all costs on the middle Niemen front and at Brest. If that case did not arise, then the *couverture* was strong enough to enable the main masses using the northern corridor to detain further forward. In proportion as the arrangements for mobilization and concentration were improved in the years 1910-4, and in proportion also as it became more probable that Germany would elect to employ the bulk of her forces on her French front, not only this forward concentration but also preparatory offensives delivered from the *couverture* line came to be considered.

In all cases the main object which was to be sought when the forces were fully assembled was practically the same. It was the destruction of the Austrian armies in Galicia, the occupation of the Carpathian line, and eventually an advance into Moravia and Silesia by Troppau and the Oder head, turning Breslau. The exact form in which this ultimate offensive would be realized could not be foreseen until the Germans and Austrians had shown their hand; meantime, the problem before the Russian general staff was so to plan their *couverture* arrangements, their detachments, and their now feasible preparatory offensives as to subserve this purpose.

Generally speaking, the *couverture* on the Narew-Bober, that on the middle Niemen, and that in the Szavli region were disposed and directed to checking as long as possible any German attack on the flank of the northern corridor. It would be reinforced *in situ* to the strength of two armies and an independent group. If powerful German attacks developed it would offer an elastic defence, on one line after another, to protect at all costs the region of Białystok-Grodno-Vilna during the troop movements in that area. If not, it was to take the offensive and, by conquering E. Prussia to the Vistula, definitely to secure the right rear of the future main effort. This conquest was to be carried out from the S. by Mława, turning the lake barrier, by one army while the other pressed up against the front of the lakes and the Angorapp, so as to occupy the Germans and at any rate to prevent a rush upon Kovno and Grodno. The independent group about Szavli was to deal with minor enterprises of the enemy in its own area, and especially with landing threats on the Baltic coast as far as Riga. From that point inclusive, coast defence was entrusted to another army, with headquarters at Petrograd.

In the centre two armies, coming from the interior by the central and eastern railways of the corridor, were, if possible, to





concentrate about Lublin and Chelm respectively; otherwise they were to divide, one going to the right of the defensive wing about Shavli, the other continuing S. to Brest and Kobrya. Supposing that this proved unnecessary, the two armies, from Lublin and Chelm respectively, were to take the offensive against the left of the Austrian armies in Galicia. The right of these meantime would be attacked by two other armies, advancing from Dubno and from Proskurov. These armies were given special precedence in their equipment, so as to be ready to act early. At Odessa, a minor army of reserve divisions was to be assembled to watch Rumania.

Defensive or offensive as the case might be, these preparatory engagements were all assumed to be in progress before the full concentration had been effected. Including the Petrograd army, only 28 out of a total of 37 active corps were comprised in the dispositions, and the reserve divisions formed on mobilization were not counted upon for immediate service. The remainder, in so far as no new complications occurred to tie them to their peace regions (e.g. Caucasus), would become successively available and constitute a mass of manoeuvre or a pool of reinforcements, according to the course of events.

On mobilization, accordingly, the allocation of troops was as follows:—

I. Army (*Rennkampf*). Niemen, including Shavli. II., III., IV., XX. Gd., I. Corps. (As soon as relieved by reserve divisions [XXVI. Corps] at Shavli, XX. Gd. was to proceed to IV. Army.)

First task: protection in front of Niemen line, on that line, or if necessary further back towards Vlna. Second task: advance to bind the German forces on the lakes and Angerapp.

II. Army (*Sansonn*). Narew. VI., XV., XXIII., XIII. Corps. First task: protection of Bobr-Narew-Bug line and reconnaissance into Mlava-Neidenburg region. In case of heavy German offensive, the region of Bialystok to be protected at all costs. Second task: invasion and conquest of E. Prussia via Mlava, turning the lakes. (These two armies had each several reserve divisions allotted.)

IV. Army (*Ebert*). Concentration area Lublin. Grenadier, XIV., XVI., XVIII. Corps.

V. Army (*Plathe*). Concentration area Chelm. V., XVII., XIX., and XXV. Corps.

Both for attack of N. front of Austrian armies in Galicia.

III. Army (*Ruzsky*). Concentration Rovno-Dubno. IX., X., XI., XXI. Corps.

VIII. Army (*Brussilo*). Concentration S. and W. of Proskurov. VII., VIII., XII., XXIV., III. Caucasian Corps.

Both for attack of N.E. and E. front of Austrians in Galicia.

The I. and II. Armies formed the north-western front under Gen. Zhilinsky (succeeded after the first operations by Ruzsky), the IV., V., III., VIII. the south-western front under Gen. Ivanov whose Chief of Staff was Alexeyev.

The VI. Army (*Grand Duke Nicholas*) was the title of the Petrograd force, the VII. (Nikitin) that of the Odessa troops.

(In the event of German offensives developing on a large scale, requiring the adoption of the rear line of rail-heads, the IV. Army was to be switched *en route* to the right of the I., and to it instead of to the VIII., the XXIV. Corps was to go. It would also become part of the north-western front.)

The peace-time scheme, as thus outlined, was at once modified in the early days of mobilization, not so much in intentions as in allocations of force. No commander-in-chief of the whole was appointed before the war, as the Tsar was undecided as to whether to take command himself. At the outbreak of war the Grand Duke Nicholas, Commander of the VI. Army, was appointed. He had taken no part in drawing up the scheme, and his own ideas differed somewhat from it. He therefore formed a new scheme, or rather a modification of the basic scheme, whereby the Guard and I. Corps were dispatched to Warsaw (instead of to the I. Army) to form the nucleus of a IX. Army, and the VI. or Petrograd Army was reduced first to one corps, and then to reserve divisions only. The first corps to leave was the XVIII., originally intended for the IV. Army but now assigned to the IX. (replaced in the IV. by the III. Caucasian Corps taken from the VIII. Army). The XXII. followed towards the end of August, joining the I. Army in lieu of the Guard and I. Corps. Further, a number of the reserve divisions accumulating behind the I. and II. Armies were constituted a little later as a X. Army with the mission of connecting the I. and II. Armies—but too late to avoid the catastrophe of Tannenberg.

Mobilization and concentration proceeded rapidly. The cavalry divisions allotted to the Prussian front were detrained completely by the 7th day of mobilization, the infantry corps by the 13th day. On Aug. 14 the Grand Duke informed the French ambassador that the I. and II. Armies would open their offensive on the morrow, considerably sooner than was expected by the French, who only began their advance on that day.

The "preventive" offensive that was to lead to Tannenberg was thus launched on Aug. 14. Its objects were, partly, the accelerated fulfilment of the original plan of campaign (at the lowest, the active flank defence of the northern corridor, now being traversed by a IX. Army as well as the IV.); and partly, the desire to aid France by startling the German command into making detachments to the E.

*Plans of Campaign—Central Powers.*—The problem of war on two fronts had for many years been anxiously studied in Germany and it had been generally accepted in principle that a simultaneous offensive E. and W. was impossible. In the time of the elder Moltke, the difficulty of defending the long, open eastern frontier, as compared with the relative ease with which the short, strong line Thionville-Strassburg could be held, had decided the great general staff in favour of choosing the east as the offensive theatre; and this plan held the field, with few modifications, until Schlieffen came into office as Chief of the General Staff and reconsidered the military position. He decided that the first offensive must be directed against France, but in such a way as to insure the quick and complete destruction of the French army, i.e. by using Belgian avenues for the envelopment of its left. His solution of the two-front war problem, therefore, was to prevent its happening: neither he nor his successor, the younger Moltke, seems to have dealt exhaustively with the case that actually arose, i.e. that of a prolonged contest in which the centre of gravity constantly required to be shifted from E. to W. and vice versa. An important factor, perhaps the ruling factor, in the decision was the assumption that it would be impossible to bring the Russian army to decisive battle; owing to its slow assembly, the distances to be traversed in order to reach it required a time allowance which the western defensive, at grips with the highly trained and efficient French army, could not insure for it. Moreover, with unlimited space behind them the Russians were regarded as having every chance of avoiding a decision for as long as they wished to do so, and the re-distribution of the Russian peace garrisons after 1910 (which pointed to the choice of the rear line Kovno-Bialystok-Brest as the probable line of entrainment) confirmed the conclusion. Two possible offensive directions were considered, that from the Mlava region against the Narew line, and that from the lake front by Wirballen and by Augustowo and Suwalki against Kovno and Vlna. These alternatives and their meaning have been alluded to already. The choice was a difficult one, hardly to be settled except *ad hoc*; it was to be the chief bone of contention between Falkenhayn and Hindenburg in the 1915 campaign. But even the second, and more promising, line of operations would not lead to the enemy's rear if he abandoned all Poland at the outset, and concentrated between Kovno and Brest.

In fact such a course of action was provided for in the Russian concentration scheme. But the alternative preferred by the Russians was an offensive, or two offensives, carried out by the readiest portion of their forces, and their alternative naturally engaged the attention of the Central Powers in the years after 1910, when the war-readiness of the Russian army was evidently being improved with menacing rapidity. The defence against such an attack could not readily be combined by the two Central Powers because of the salient W. of the Vistula; on the defensive, therefore, Germany and Austria-Hungary formed two theatres, either or both of which might be the target of enemy offensives of uncertain power. Further, the entire peace forces of the Central Powers, taken together, were not equal numerically to the peace forces of Russia, and the adhesion of Turkey, and still more that of Rumania, to their side was problematical. If the bulk of the Russian forces concentrated on the forward line, then there were only two practical alternatives for the Central



Powers: either (a) to concentrate as much as possible of the German army in the E. (relying upon the short and well-fortified defensive line of Lorraine and Alsace, doubled by the Saar and the Rhine, to hold up the French), and to take the offensive with 90 or 95 divisions, German and Austro-Hungarian, as soon as possible so as to catch the enemy in the act of detrainment; or else (b) to stand on the defensive, each in his own theatre of war, resigned to give up territory in order to gain time for the annihilation of the French.

But that annihilation effort would require at least four-fifths of the German mobilizable forces, if it were to be carried out in the short time that the conditions of the E. allowed, and in the case of Germany the territory that would have to be resigned was E. Prussia, bound indissolubly to the Hohenzollerns and to the Prussian army by ties of sentiment and tradition. Its abandonment was "unthinkable." Yet the force that could be spared to defend it was small indeed. The Reichstag had declined to sanction the creation of the three new army corps which would have eased the problem; and, in the event, one to two corps allotted in principle to the E. were taken at the last moment for the W. In short, the German army allotted to the E. was a minimum force. But it was not on that account authorized to give up any German ground.

The case of Austria-Hungary was more favourable to this extent, that nearly the whole force of the Dual Monarchy could be employed in the defence of Galicia, unless (as actually happened) offensive action was simultaneously undertaken in the Serbian theatre. On the other hand, Galicia would clearly be the enemy's principal target, and were he to leave mere flank guards against E. Prussia, there was little doubt that even in an accelerated offensive he could employ superior forces. Many Austrian authorities therefore favoured a withdrawal of the line of defence to the Carpathians, and probably the majority considered that nothing could be held in advance of the San-Dniester barrier. The problem then was difficult and obscure, and differences of opinion both within each country and between the two countries themselves were certain. Austria's strategy even in respect of her local problems depended largely upon Germany's, and no definite, binding convention appears to have been negotiated, either for the case of the offensive or for that of the defence. More, the interchange of views which did take place led to completely disjointed action. When the inner wing of the Austro-Hungarians was driving forward the offensive on Lublin and Chelm, the Germans in E. Prussia were under orders to retreat to the Vistula.

Conrad von Hötendorf, the head of the Austrian general staff, was essentially active in temperament, and the wave of sentiment in favour of the undiluted offensive which swept through all European armies about 1912 strongly influenced him and his entourage. A scheme was prepared under which the left portion of the Austro-Hungarian army was to take the offensive from the lower San, northward on Lublin and Chelm, flank-guarded by an échelon directed on Vladimir Volynsk, while the right portion defended Lemberg against attack from the E. In co-operation with this left wing, a German army was to advance by Mlava on the Narew line, force this, and effect a junction with the Austrian advance about Siedlce. By this scheme it was hoped either to cut off a part of the Russian army and beat other parts in detail as they detraind—if the Russians were attempting to forward concentration—or to make good military occupation of almost the whole of Poland in the shortest time—if they were concentrating on the rear line Kovno-Brest. At the lowest, Conrad held, the protection of Galicia and of E. Prussia would be best assured by the offensive.

In how far Moltke agreed to this plan is doubtful. He had definitely committed himself to the Schlieffen scheme of putting France out of action before an eastern front came into existence, and though he had considerably altered its details, he had provided even less force for E. Prussia than Schlieffen had proposed. Such evidence as is available tends to show that Moltke agreed with the scheme, as the operative idea of the eastern offensive that was to follow the decisive defeat of France (expected to

have been sufficiently achieved by about the 30th day of mobilization), but not as a preventive offensive to be launched while the issue in France was still undecided. Conrad, on the other hand, was determined to carry it out the moment he was ready, hoping, as he said, that Moltke would not "leave him sitting in the ink too long." The scale of the operation for him was only that of a preventive offensive, carried out substantially by about 27 Austro-Hungarian and 20 German divisions from the San and from the Mlava region respectively. This force, if it caught the Russians in the act of concentration, would create "favourable conditions for later operations" on a large scale.

Moltke, on the contrary, gave the E. Prussian Army (VIII., Gen.-Oberst von Prittwitz und Gaffron) nine active and reserve divisions (I., XVII., XX. Active Corps, I. Res. Corps, 3rd Res. Div.), for both the lake and the Mlava fronts. Apart from a number of Ersatz and Landwehr formations, most of which were intended for the defence of Thorn, Graudenz and Königsberg, this was all. In Posen province and in Silesia, there were only frontier guards of Landsturm, and the Landwehr and Ersatz garrisons of Breslau and Posen; as the salient facing these provinces was practically evacuated, no more was necessary, and indeed eight Landwehr regiments were grouped in Upper Silesia as a field force (the "Landwehr Corps," von Woytsch) to accompany and guard the left of the Austrian offensive.

Thus, the first campaigns in the E. were distinct and without connexion of idea or of date. The battles of both being described elsewhere, it is sufficient here to outline the campaigns of Lemberg and Tannenberg in succession.

*The Campaign in East Prussia; August-Sept. 1914.*—The first requirement of the Russian scheme of operations being the use of the northern corridor for the assembly of forces against the Austrian left, the troops disposed on the dangerous flank of the corridor were ready for action about ten days before the date set for the completion of the Lublin-Chelm concentration. In the original scheme, their mission was primarily defensive and in the second place offensive, but as early as Aug. 9 the Grand Duke determined to push forward both the I. and II. Armies on their offensive missions, in the hope of at once compelling the Germans to hold back forces destined for the W. On the 14th, their concentration completed, these armies moved out of the detrainment areas, the I. (II., III., IV. and XX. Corps) under Rennenkampf on the axis Kovno-Gumbinnen and Suwalki-Masgrubova, the II. (VI., XV., XXIII., XIII. and later I. Corps) under Samsonov on the axis Pruzhany-Soldau. Seven to eight cavalry divisions, accompanied and preceded them. At many points on the frontier from Memeł to Biella and round to Mlava there had already been local engagements, especially on the axis Kovno-Gumbinnen, where Rennenkampf on the one side and von François (commander of the German I. Corps) on the other had both strong motives for activity, the Russians to thrust back the enemy's forces as far from the "corridor" as possible, the Germans to preserve the region before the frontier and the lakes as long as possible from occupation or pillaging. On the Mlava axis these episodes were fewer, for the Russian main bodies were more distant. The Germans were unable to prevent the enemy's mounted troops from ranging up to Soldau, but their Zeppelins reconnoitred the line of advance of Samsonov's main bodies.

Gen. von Prittwitz, in spite of his small forces, was confident. He placed the I. Corps (François) facing E. on and in front of the Angerapp, the XX. Corps facing S. between Allenstein and Soldau, the XVII. and I. Res. Corps and the 3rd Res. Div. in the interior, waiting on events. To the left rear of the I. Corps, the Königsberg main reserve—an Ersatz and Landwehr force numerically, but only numerically, equivalent to a corps—moved out N. of the Pregel to Insterburg. To the right of the XX. Corps was a frontier guard, also composed of Ersatz and Landwehr belonging to the fortresses of Thorn and Graudenz. On Aug. 14 v. Prittwitz, satisfied that no important threat was impending on his S. front, turned over the defence of that front to the Landwehr and Ersatz formations of Gen. von Unger, drew the XX. Corps to Ortelsburg, in readiness for an offensive to

wards Johannisburg, and brought the remainder of his forces to the E. front behind and on the flanks of the I. Corps, the 3rd Res. Div. (reinforced by one brigade and a screen of Landsturm posts) holding the lake barrier.

On the 17th took place the first serious encounter of large forces. Von François still maintained a forward position on the Kovno railway at Stallupönen, barely five miles inside the frontier; he was determined to defend offensively; and he inflicted a sharp blow on the central columns of the enemy before the others became effective. But his left was driven in, and Prittwitz, whose intention was by no means to fight so far forward, ordered the combat to be broken off and the troops to retire to the Gumbinnen position. There, on the 19th and 20th, the battle of Gumbinnen was fought. Claimed by both sides as a victory but in fact indecisive, since parts of each line gained successes or suffered failure, it ended in Prittwitz's ordering the battle to be broken off. To the astonishment of his corps commanders, he announced that he proposed to retreat over the Vistula. A grave crisis had arisen. The Russian II. Army, seemingly quiescent on the Narwé, had in fact been cautiously advancing on the Mlava axis, which was now defended only by second-line troops and, partially, by the XX. Corps—everything else, even mobile Landwehr brigades, having been brought over to the E. front by the order of the 14th. Such was the situation of the defences when, some time after noon on the 20th, reports reached Prittwitz to the effect that four or more Russian corps were approaching Mlava and Ortelburg. He had three alternatives—to disregard the threat, win an effective victory at Gumbinnen, and pursue the enemy in such a way as to impose caution on all Russian forces in advance of the sensitive point of the "corridor"; to leave a containing force about Gumbinnen, trust to the lake barrier, and bring back the bulk of the forces so as to strike the flank of the oncoming II. Army; or to fall back beyond the sweep of that army's manoeuvre. The first alternative was eagerly advocated by von François, but the other corps had met with little success in the battle. It is probable that no reasonable hope remained of winning a thorough victory on the 21st, and nothing less would serve. The second alternative was not, at that moment, considered and the third was adopted in its most extreme form, retreat beyond the Vistula. The I. Corps was to move by train to Bischofswerder and Gosslerhausen, in order to bar the road to the Vistula, the XX. to fight for time, and the remainder to withdraw south-westward under cover of these corps. A factor in the decision was the activity of Russian cavalry which, in large and small bodies, was appearing in the interior of the province.

In the *Kriegsspiel* exercises of peace-time, this problem had often been fought out, and the idea of sacrificing E. Prussia—in paper—was familiar. But, as the elder Moltke observed in 1866, "in practice one does not abandon provinces." On the 20th, apparently on the initiative of Lieut.-Col. Hoffmann of the staff of the VIII. Army, who sent a protest direct to supreme headquarters at Coblenz, Moltke communicated with Prittwitz by telephone, and urged him to try the alternative of a manoeuvre on interior lines. The army commander replied that this was impossible and that he might need reinforcements even to secure an escape to the Vistula. Thereupon Moltke relieved him of his command, opened direct telephone communication with von François and von Scholtz (XX. Corps), telegraphed to General-Oberst von Hindenburg, in retirement, to offer him the command, and summoned Ludendorff (deputy chief of staff II. Army) to act as chief of staff.

This situation, in fact, was less alarming than it had been on the 21st. Neither Rennenkampf nor Samsonov displayed any important activity; and Prittwitz recovered confidence, decided to hold the line of the Passarge against Rennenkampf, and began to work out a scheme of attack against the Russian III. Army. But the order of dismissal reached him that evening. On the 23rd Hindenburg and Ludendorff arrived at Marienburg (H.Q. VIII. Army). Already, after a conversation with Moltke, Ludendorff had (apparently on a suggestion from François) fixed Deutsch-Eylau and eastward, instead of Goss-

lerhausen, as the rendezvous of the I. Corps and ordered all available Ersatz and Landwehr units from Thorn and Graudenz to strengthen von Unger, this beginning to prepare a group of two active corps and other troops to check Samsonov. The other forces lately engaged at Gumbinnen were to remain, temporarily, opposing Rennenkampf—all measures designed, evidently, to arrest the sense of retreat and panic. Not until the staff of the VIII. Army had reported the situation in detail was a clear idea of possibilities formed by the new leaders. In principle the plan was adopted of holding up Rennenkampf, maintaining the lake region against any break-in from Lomaha, and concentrating offensive effort on Samsonov. Both the newcomers and the staff already on the spot were in agreement as to this. But it remained to be seen whether, and even how, it was to be accomplished. On the evening of arrival, Hindenburg reported to Coblenz "assembly of army at XX. Corps and enveloping attack planned for Aug. 26," but next evening developing the idea in some details, he added: "moral determined but no impossible things turn out badly."

The intention was to disengage some, or even all, of the troops opposing Rennenkampf, and with them by a flank march close behind the lakes, to envelop Samsonov's right; to bring in the I. Corps and the nearest portions of von Unger's force against his left, and to hold him frontally with the XX. Corps. It was on this last that everything hinged. Short of a simultaneous effort by both Rennenkampf and Samsonov—the case feared by the Germans—pressure by the II. Army alone was of greater significance than that of the I. Army alone would be. Rennenkampf, however active, could only drive the I. Res. and XVII. Corps south-westward towards the Passarge (and the Königsberg troops into their fortress) and work a passage down the rear side of the lakes to join hands with Samsonov, whose VI. Corps was made to diverge towards Ortelburg for that purpose. Samsonov, on the contrary, could by an energetic advance bring three corps (XIII., XV., XXIII.) against Scholtz, and in case of success break into the midst of the new dispositions of his opponent. On the 23rd-24th this seemed probable, for on those days he attacked the XX. Corps and forced it to swing back from the line Gilgenburg-Orlau to the line Gilgenburg-Hohenstein. At that moment the 3rd Res. Div. at Hohenstein and even the first arrivals of the I. Corps at D. Eylau were being drawn into the fight to assist von Scholtz. The arrival of the rest of the I. Corps, destined for the flank attack on the W., was delayed by misadventures; and this western attack (I. and Unger) was itself becoming imperilled by the advance of yet another Russian corps, the I., from the IX. Army forming at Warsaw. Of the other German corps not one was disengaged for its southward march before the 24th.

On the 24th, however, the withdrawal from Rennenkampf's front began. It was carried out in the midst of an emigration *en masse*, main roads being so crowded with refugees that troops were marched in some cases entirely by tracks and by-roads. Russian cavalry parties were by now riding about the country as far as the Passarge.

The Angerapp line having been given up on the 22nd, the front of contact opposite the Russian I. Army now (24th) ran along the Deime and the lower Alle, astride the Pregel, to Allenburg, thence by Gerdaun to Angerburg at the N. end of the lakes. North of the Pregel, the Königsberg force was slowly retiring on its fortress and had left Wehlau. South of it there were withdrawn, each in succession and covered by the rest, the XVII. Corps, which was directed on Bischofsweg-Ortelburg; the I. Res. Corps, directed upon Seeburg; and finally the 6th Landwehr brigade from Lötzen, the key of the lakes, to the same region. Only the Königsberg force, one cavalry brigade and some Landsturm, remained in front of the Russian I. Army.

Meantime, Samsonov continued his methodical advance, but very slowly—the VI. Corps on Bischofsweg via Ortelburg; the XIII. on Allenstein; while the other two, followed in echelon to the left rear by the I. Corps, were sent against Scholtz (20th and 3rd Res. Div.), whose left was driven from Hohenstein. But already the two wings of the envelopment were being pre-

pared and directed according to the indications of Russian wireless messages sent in clear. On the W., the German I. Corps, with additional troops under Müllmann coming up on its right, attacked towards Usdau on the 26th. On the same day the Russian VI. Corps was met and defeated at Gross-Bössau by the oncoming eastern enveloping wing. Von der Goltz's Landwehr division, arriving opportunely from Schleswig-Holstein, was added to Scholtz's threatened flank. From the 26th the battle was general. Strategy had done its part. By the 31st the destruction of Samsonov's army by double envelopment was complete, only the attached I. Corps écheloned back on the left being outside the ring and able to escape as a formed body. Samsonov himself fell, and 92,000 prisoners and 300 guns remained in the hands of the victors.

Meantime the German supreme command at Coblenz had taken a step which is generally regarded as having been fatal to Germany's success in the war. Moltke had recognized from the first that the strength of the VIII. Army was little above, if not below, the safety limit, and in the background there was Conrad's repeated demand for effective cooperation in the Siedlce scheme. Only after much hesitation was the IX. Res. Corps in Schleswig-Holstein taken to reinforce the W. on the strength of Pritwitz's optimistic reports on the eve of the battle of Gumbinnen. Two days later came the crisis which led to Hindenburg's appointment, but at that moment the battle of the Frontiers was developing all along the line in the W. and Moltke did not suggest (nor did Ludendorff ask for) a reinforcement of the E. On Aug. 25, however, caught apparently in a wave of optimism which pervaded the armies of the W. after five simultaneous victories, Moltke decided to send no less than six army corps to the VIII. Army, not so much in order to re-establish a compromised situation there as to deal the offensive blow in the E. that was only waiting upon a decision in France. Two corps were to go from each portion of the western front, and the Guard Reserve and XI. Corps, being reported by their army commanders, after the fall of Namur, as free, were sent first, along with the 8th Cav. Div. In the event, the other four were never sent, as the results of Tannenberg altered the balance of forces in the E. at the same time as a new crisis was arising in the French theatre.

These reinforcements arrived too late for the battle of Tannenberg, but began to be available in the first week of September. Meantime the VIII. Army Command had to decide whether to pursue immediately to the southward, forcing the Narwé line and making rendezvous with Conrad about Siedlce, or to deal with Rennenkampf's army which still stood, inactive but threatening, on the Deime-Wehlau-Allenburg-Angerburg-Bialla line. The latter course was preferred, as was practically inevitable. The progress of the Austrian I. Army and Woynsch (see below) in the Lublin region was evidently being neutralized by the advance of Ruzsky and Brussilov in E. Galicia, and Rennenkampf's inactivity could hardly continue. Moreover, he occupied a great part of E. Prussia and the call of the civil population for rescue from the Cossacks could not be ignored. Rennenkampf's halt on the Deime-Angerburg line, when enemy forces were daily slipping away from him to take part in the destruction of Samsonov's army, was and is severely criticized, and exposed him to the reproach even of treason. Part at least of the causes of this passivity lay in the inherent slowness of Russian military practice—a slowness which equally characterized the unfortunate army of Samsonov, as we have seen. For the rest, it is to be noted that the Grand Duke was himself at Insterburg during the critical days. Such evidence as is available suggests that the intention of the Russian supreme command was not to press even Samsonov's offensive, still less the frontal advance, farther than it would go, but to give the whole campaign a wider sweep by means of the new IX. Army assembling at Warsaw and intended to move on Thorn and Posen,<sup>1</sup> turning the Vistula barrier from the south.

<sup>1</sup> The I. Corps of this army was not placed at Samsonov's disposal till Aug. 26, the Guard not at all. One cavalry division was actually taken from Samsonov.

From the German point of view, although information was no doubt lacking as to the large undisclosed reserves moving in the "corridor," it must have been clear that the defeat of Rennenkampf would effectively answer any renewed threat from the S. by endangering the Grodno-Kovno artery. In the conditions of the moment this defeat could best be ensured by attacking his left wing, and in the first days of Sept. the VIII. Army with the corps from the W. were disposed accordingly on a long line from Preussisch-Eylau to E. of Willenberg: in order from left to right Guard Res., I. Res.; XI., XK., XVII., I. Corps and 3rd Res. Div. Von der Goltz with his own division and another made up from Unger's and Müllmann's forces (called 35th Res. Div.) watched the southern front on both sides of Mlava. The Königsberg force still held the Deime line. On his side Rennenkampf had already brought up two of his reserve divisions from the Niemen for the siege of Königsberg, and he now strengthened his left from both active and reserve formations assembled about Grodno. As had been the case at Tannenberg, the forces were numerically almost even. On neither side was any important concentration of force at particular points effected and the resultant battle, known as the battle of the Masurian lakes, or of Angerburg, was practically "linear."

The idea pursued by Hindenburg was to press the Russian right, as far S. as Angerburg, with four corps, to break out of Lötsen (the key of the lakes, which had been kept throughout) with the XVII. Corps while the I. Corps and 3rd Res. Div. advanced from their Tannenberg positions eastward along the frontier railway. These 3½ corps were intended to roll up the left of Rennenkampf and press northward, with an échelon to the right against the fresh enemy forces reported detaining about Grayevo. The battle began on Sept. 7 and on the 8th was general. But the lake barrier this time favoured the Russian. The German XVII. Corps made only slow progress in advancing from the pass of Lötsen, and most of the I. Corps was soon drawn north-eastward. The balance, however, passing S. of the lakes along the axis Johannisburg-Bialla, made marked progress, and on the night of the 9th-10th Rennenkampf decided to take down his front by successive fractions from right to left, and retire into the Mariampol region whence he had come. The battle then became one of tactical incidents, with all the local vicissitudes of a general chase. At the end, thanks to the traditional rearward aptitudes of the Russian soldier, Rennenkampf's army had flowed away to safety, leaving the bulk of the VIII. Army congested round Vladislavov and Eydtshines with the I. Corps E. of Vilkoviashki and the 3rd Res. Div. at Suwalki. Goltz's southern column had meantime extended eastward as far as Marggrabowa.

The battle of the Masurian lakes freed E. Prussia, and the victors gleaned a harvest of some 30,000 prisoners in manifold combats amidst woods and lakes. But it was not a Tannenberg, and already events elsewhere were in progress which involved the VIII. Army in a general eastern front campaign.

*The Galician Campaign of August-September 1914.*—As has been said above, Conrad had determined to carry out the offensive in the region Lublin-Chełm, where the Russians were concentrated, though without definite assurances of cooperation from E. Prussia. In the offensive, the forces to be employed formed two armies—the IV. Army (Auffenberg), consisting initially of the II., VI., IX. and newly formed XVII. Corps, and four cavalry divisions; and (detachment area Yaroslav-Przemysl) the I. Army (Danzi), I., V., X. Corps and two cavalry divisions (detachment area middle and lower San).

East of Lemberg it was intended to place two armies, the II. and III. But owing to the belief that the war crisis would be limited and localized as a campaign against Serbia, the II. Army was assembled initially on the Danube, and could only be brought N. by degrees. At the outset it was represented in Galicia only by the Army-group Kövcs (XII. Corps and some extra divisions S.E. of Lemberg and on the Dniester), but the IV. and VII. Corps were being disengaged from the Serbian front and sent up gradually. The III. Army (Bruderman) E. and N.E. of Lemberg consisted of the XI., XII. and XIV. Corps

said some other divisions, of which the XIV. Corps was presently taken to form the Army-group of Archduke Josef Ferdinand and placed N. of Lemberg to maintain liaison between the IV. and III. Armies, intervening as required by either.

On the left of the I. Army, along the N. side of the upper Vistula (i.e. in the Polish salient) an Army-group under von Kummer, formed of Landsturm troops, and to the left of Kummer, the German Landwehr Corps of Woyrsch, were to advance in the direction of Sandomir and Ivangorod respectively, driving back such Russian mounted forces as remained in this region. These formed an echelon protecting the left rear of the I. Army, but were primarily intended to form a rallying-point for an insurrection in Poland. This hope was not realized, or realized only to a small extent, and the "Polish Legion" that was formed in fact consisted largely of Galician Poles.

The Archduke Friedrich was commander-in-chief, with Conrad as chief of staff and effective director of operations. The campaign which ensued constituted in reality a chain of battles and as such is described elsewhere. Here it need only be summarized very broadly. Apart from the movement of Kummer and Woyrsch, who started early, in order to be in position at the date of the general advance, the campaign opened on Aug. 20. Prior to that date, the Austrian cavalry divisions had made many attempts to ascertain the Russian movements in the "southern corridor" and the adjacent parts of Beszabia, but without obtaining much information. The Russian masses were in fact still in the stage of rail transport, and their mounted troops, trained to fire action and favoured by the country, easily kept the screen intact. The Austro-Hungarian offensive was therefore in its first stages carried out according to the *a priori* scheme.

The objective of the I. Army was Lublin, that of the IV. Chelm; they therefore aimed at the concentration centres of the IV and V. Russian Armies respectively, and the conditions of this concentration led to a series of encounter battles in which the Austrian left was constantly echeloned forward, with the result on the other side that the Russian V. Army's tended to strike south-westward rather than southward, and so in turn exposed a flank to the Austro-Hungarian IV. Army. This army, again, depended for security on its right upon the Army-group (Josef Ferdinand), which was itself attracted now to the N. for intervention in Auffenberg's battle, now to the E. to protect Brudermann's exposed left. On the one side, therefore, an advance in echelon, on the other successive detrainments, produced a battle of marked day-to-day fluctuations. The I. Army in a series of combats collectively called the battle of Krasnik reached the line S. of Chodel-Borzechow-Turobin by Aug. 26, against increasing Russian resistance especially on the left nearest Lublin, where it was found necessary to bring Kummer and Woyrsch E. of the Vistula in order to strengthen the forces aiming at that place, while the right advanced to Krusnostov. On Dank's left, meanwhile, Auffenberg was advancing into the area between the Wieprz and the Huczwa, and on Aug. 26 the battle of Komarów began. In this, between Aug. 26 and Sept. 1 the Austrian IV. Army broke the Russian V. Army into two fractions, the more important of which, half-encircled, only escaped through a maladroit withdrawal of that part of the Austrian army which had seized its line of retreat. The withdrawal of the one Russian fraction to Chelm and the other to Hrubieszow on the Bug, with heavy losses, constituted a signal victory, and would have had great results but for events in E. Galicia.

There, in accordance with the prevailing doctrines and also in order to keep Russian influences as far as possible from the Ruthenian capital, Brudermann III. Army, and Böhm-Ermoldi II. Army (the really Army-group Kövess) had been sent forward to carry out an offensive defence, although in the one army Josef Ferdinand's group was limited in its range by its liaison task, and in the other the IV and VII. Corps were still on their way to the theatre of war. This numerically weak offen-

sive encountered the Russian III. and VIII. Armies as full force—as has been mentioned above, these armies had been given priority in equipment and otherwise—and was brought to a standstill in the battle of Zloczów (Aug. 26-27) fought on the line upper Bug-Zlota-Lipa. On Aug. 29-30 a new battle, defensive this time, was accepted and lost on the Gnila Lipa (battle of Przemyslan) and the III. Army fell back on Lemberg itself, which the supreme command thereupon decided to give up. It was evacuated on Sept. 5.

Thus Conrad was confronted with new problems. His left, army (I., Kummer, Woyrsch) was already close upon Lublin, the victorious IV. Army pushing towards Chelm with its main body and Hrubieszow with its lesser half. In the region of Sokal and Rawa Ruska only cavalry activity had occurred, and Rusky's right wing was treading to the S.W. in the Lemberg direction. The beaten III. and II. Armies were assembled in good order on the strong line of the Grodek lakes (near Wesserskyj), while no important attack had developed on the Dniester. There were, substantially, three courses open—to pursue the northern offensive, trusting to distance and water to make interference with the right flank impossible during the necessary time, to take down the whole northern front, and come back to the Vistula-San-Dniester position; and to use the advantageous position of the IV. Army for a manoeuvre on interior lines against Rusky's right flank. In principle, he preferred the first course, and as we have seen, he invited Hindenburg's cooperation in the still valid Siedlce scheme. But Hindenburg declined, as *Reinnekampf* had not yet been dealt with, and opposition in front of the I. Army had visibly stiffened. The second alternative had obvious advantages and disadvantages; in the existing conditions, the disadvantages which had weighed heavily in peace-time—that E. Galicia was thereby abandoned—no longer applied since that region was now lost, and the preservation of the only available armies of the Dual Monarchy was of the highest importance. Nevertheless, Conrad chose the manoeuvre on interior lines, as the VIII. German army had done. It may be that Tannenberg contributed to the decision.

The germ of this idea appeared in the orders for Sept. 2, in which the IV. Army was ordered to suspend its offensive and change its front from N. to S. in readiness for a south-westward attack towards Lemberg, or for a south-eastward retreat towards the San. At the same time the lines of communication of each army were shifted westward, so that the base of the system became the region between Cracow and the Carpathians. The effort of the I. Army to gain ground northward was not given up, so that in effect, at this date, the supreme command had not made up its mind. In the orders for Sept. 4, on the other hand, the choice was definitely made in favour of a IV. Army offensive in the Lemberg direction, though the I. Army, Kummer, and Woyrsch, were still left with their mission unchanged.

On the 6th, the complicated manoeuvre of the IV. Army was completed, but in its southward progress it had developed considerable opposition on the E. flank, while the W. and centre passing by Rawa Ruska and Niemirów met little or none. The result was that the army practically swung into line with the III. instead of striking from N. to S. against the assault of that army. On the 7th, therefore, Conrad changed his plan again. The Austrian leader now proposed to take down the northern front by degrees, to use the IV. Army as a fixed pivot between Rawa Ruska and Magierów and to swing up the II. and III. Armies against Brusilov. This plan came to nothing, Russian pressure increased on the front of Woyrsch, Kummer, Dank, and the Russian V. Army, beaten at Komarów, resumed the offensive against the group of divisions under Josef Ferdinand which had been left by the IV. Army to protect its rear. Finally, Rusky's right, augmented by a process of regrouping which had been going on at the same time as that of the Austro-Hungarians, emerged in great strength on and beyond Auffenberg's left, N. of Rawa Ruska. There was no surprise, as marked indications of such a move had been discovered in the southward advance of the northern army. But when the Russian X. Army, joining the general offensive, began to drive

<sup>1</sup> In fact, it was wholly absorbed in the battle of Komarów.

into the weakly held gap between Dankl's right (Krasnostav) and Aussenberg's left rear (group Josef Ferdinand about Laszczów), Conrad gave up the battle altogether and ordered a retreat to the line of the San and the Carpathians. The various forces along the Dniester retreated to the Carpathians, the II. Army to the region of Sambow, the III. to that of Przemysl, the IV. to Yaroslav, and the I. with Kummer and Woyrsch to the lower San (Sept. 11-15).

On this line, however, no stand could be made. Already on the 14th the Russian IV. Army, strengthened from the assembling IX., had been able to force a passage of the San near its mouth. The Austrians thereupon resumed their retreat southward (followed up in the later stages very cautiously by the Russians) and stood on Sept. 22 on the line of the Wisloka, the Wislok and the Carpathians. Przemysl was left to be defended by its garrison. On the 26th the retreat came to an end on the line of the Dunajec-Tarnow-Gorlice-Usciaie-Ruskie-Carpathians. But at that date, the German IX. Army was beginning to assemble in Upper Silesia. The eastern front had come into being:

*The Vistula-San Campaign (October 1914).*—In the last stages of the Marne battle Moltke had been succeeded, in effective direction of the German operations, by von Falkenhayn. Possibly because he had held, and for a time continued to hold, the office of war minister, certainly from judgment and temperament, Falkenhayn took a broad view of the eastern front problem from the first. The war, after all, had become a war on two fronts instead of two successive single-front campaigns, as had been hoped, and it would have to be conducted accordingly. This involved, first, a more intimate coöperation between the German and the Austro-Hungarian forces than had existed hitherto; secondly, the necessity of keeping the Austro-Hungarian army, in spite of its heterogeneous composition and known deficiencies, in a fighting condition similar to that of the German forces working with it; and thirdly, constant reconsideration of eastern plans, whether German or Austrian or joint, in the light of the situation on the western front; that these three were interdependent the first united operations clearly showed.

The immediate problem was to fulfil the second requirement without neglecting the third. This meant, in concrete form, the reestablishment of the Austro-Hungarian army without bringing over forces from the west. At that moment—mid-Sept.—the battles of the Aisne were developing northward into Picardy and Artois. The "race to the sea" was in progress and the chance of decisive victory in the W. had not been lost on the Marne. On the other hand, it was clear that the Austro-Hungarian army had not only lost Galicia but had suffered very heavily in casualties and material, and was shaken by its experiences. The retreat to the Dunajec had on two occasions come near to disaster—in the early stages when the IV. Army's left flank was exposed and out of touch with the I. Army, and in the later stages when strong Russian efforts were made to drive the armies off their S.W. direction by enveloping the left flank of Woyrsch and Kummer. After reviewing various alternatives offered by geography and the railways, he came to the conclusion that to press the advance of the VIII. Army on Kovno-Grodno, i. e. to pursue the victory of the Masurian lakes, would not serve, and decided to form a "South Army" in Upper Silesia as a direct support to the Austrian left. At first it was intended that this should be a small army, practically no more than a reinforcement of Woyrsch, but within a few days Ludendorff's proposal to transfer the bulk of the VIII. Army to South Poland, with its implication of a serious counter-offensive campaign, was accepted. The object of Falkenhayn in agreeing to this was, by enabling the Austro-Hungarian army to reassert itself in the offensive, to gain time for achieving a decisive result in the west. The theatre in which risks were taken was, as before, E. Prussia. Hindenburg's victories had altered the situation there, and a sort of pursuit could still be maintained by a small force for some time, before the inevitable reaction set in and Rennenkampf came on again. Moreover, the barrier of the lakes and the Angerapp was now being seriously fortified, and it was to be expected that Rennenkampf could be brought

to a halt on that line or not in front of it. On the *Mlava* line, no repetition of Samsouov's offensive seems to have been feared. But as a precaution one of the 64 newly raised reserve corps was sent to E. Prussia, and two more cavalry divisions were extracted from the west. The forces of E. Prussia under von Schubert retained the title VIII. Army. Those in South Poland were designated the IX., under Hindenburg.

The Grand Duke Nicholas, meantime, was pursuing more and more vigorously the idea which was first evidenced in the creation of the IX. Army behind Warsaw. This army had been absorbed in the fighting against Dankl, but by now the more distant active corps as well as numerous reserve divisions were detoured and ready. Reinforcements had to be provided to enable Rennenkampf's I. and X. Armies to check and drive back the probable pursuit on the middle Niemen, and to reconstitute the shattered II. Army on the Narew. But even with these demands to be satisfied, enough remained for the constitution of an offensive group between Warsaw and Ivangorod. With this group he meant to transfer the centre of gravity to S.W. Poland, making Warsaw-Crasnostochowa and Ivangorod-Beuthen the principal axes of his advance. Accordingly, in the last days of Sept. and Oct. 3, the Russian army in front of the Austrians began to be reduced. And a formidable mass—the "steam-roller" for which the world waited—gathered behind the middle Vistula. Meanwhile, lighter forces, keeping level with the advance S. of the upper Vistula, had advanced beyond Kielce, Petzkov and Lods.

The Austro-German offensive thus struck the Russians in the act of regrouping. Its plan was—The German IX. Army and part of the Austro-Hungarian I. Army, N. of the upper Vistula, to advance, driving back all forces met with, to the line of the Vistula above and below Ivangorod, and there to form the pivot of a sweep of the Austro-Hungarian IV. (Josef Ferdinand) and III. (Boroevic) Armies which should advance to the San, relieve Przemysl, and then strike northward and north-eastward. The II. Army (Bohm Ermolli) in the Carpathians and the left of the I. Army (Dankl) on the Vistula about Zawichost were to conform to the movement as it developed. Danger of counter-attack upon the extreme left of the IX. Army from the Warsaw bridgehead was provided against partly by causing the various frontier guards of Posen, Hohensalza and Thorn to advance into Poland, partly by echeloning out a mixed force called Frommel's corps—chiefly cavalry—on the middle Pilica.

Moving out from the concentration area in Upper Silesia on Sept. 26, and joined on its right by the left of the Austrian I. Army from Sept. 30, the German IX. Army reached the line Klimontow (Austrian I. Army), Opatow (Woyrsch and XI), Ostrowiec (Guard Res.), Szydlowice and Ilea (XVII.), W. of Opoczno and S. of Rawa (Frommel). At that date the Austro-Hungarian I, IV, and III. Armies had also begun their advance, and reached the Wisloka, while in the Carpathians the II. Army and Hoffmann's Corps to the E. of it began to dislodge the various bodies of the Russian VII. Army that had established themselves in and beyond the passes. Along the whole front only light troops of the enemy were met, and the advance continued during the following days: But, almost simultaneously, the Austrian IV. and III. Armies were brought to a standstill on the San below and at the gap of Chyrtow which gave access to the Dniester, and both Macklenck's XVII. Corps and Frommel's mixed force advancing north-westward, came into contact with the heavy Russian forces now debouching from Warsaw.

This growing intensity of the fighting S. and S.W. of Warsaw deflected the advance of the German IX. Army northward, causing a corresponding extension of front of the Austrian I. Army, which now passed wholly to the N. of the Vistula, its left centre facing Ivangorod. On Oct. 20, the battle was yet

<sup>1</sup> The III. Army (now commanded by the Bulgarian Radko Demitriev), minus several of its units, was employed in besieging Przemysl; the VII. had come up from Besarabia and taken over the Dniester front from about Strzy eastward. Its designation was shortly afterwards altered to that of "Dniester Group," but in 1915 a new VII. Army was formed in the same region.

and along the whole front from Blonie IV. of Warsaw, by Kalyaria S. of that city, along the Vistula and the San to Przemysl (followed on the 9th), and thence across the Chyrow gap to the Carpathians. Here and there both sides sought to force the water barrier. In most cases no foothold was obtained, but where a bridge-head could be established, or where it existed as at Warsaw and Ivangorod, effort was concentrated.

By the 14th the assembly of Russian forces about Warsaw and Ivangorod was so great that no less than three army staffs were required to direct operations—in order from right to left the I. (brought down from Kovno region), the reconstituted II. and the IV. (from the San); on the left of the IV. was the IX., on the left of this the V., while the III., VIII. and VII. (Dniester Group) held the front of the San, Chyrow and the Dniester foreland. The process continued on the following days; the V. Army, taken out of the line S. of the Vistula, was put in between the II. and IV., the IX. was brought up to Ivangorod, and more and more Russian troops passed the bridge-heads; while the thinned lines of both sides contended on the San-Chyrow-Turka front without material changes, and the opposed detachments of the Russian Dniester Group and Hoffmann and Pfänzer-Baltin fought local battles on the various routes between the mountains and the Dniester.

On Oct. 17, Ludendorff, already worried of the strength of the enemy's Warsaw armies by orders and by a captured order, advised Hindenburg to retreat. The want of success on the Chyrow front indicated that the scheme for which the German IX. Army had been brought to the Vistula had failed, and the IX. Army and Dank's I. Army were now exposed to the convergent attack, from Warsaw, from Ivangorod, and from Zawichost, of five hostile armies, while Josef Ferdinand, Bórošváč, Böhm Ernólli, and the forces eastward were pinned.

The retreat after a last attempt to gather a striking force on the Pilica for a blow against the Russian II. and V. Armies made at the expense of thinning the front of the Austrians before Ivangorod—set in on the 27th, and spread from left to right as far as the Vistula above Zawichost. The San-Turka line, on the other hand, continued to be held by the Austrians, fighting being concentrated principally upon the right of the II. Army, where a break-through was narrowly averted on the 27th. During the next days, the lost ground was regained; and progress was made between the Carpathians and the Dniester by the smaller forces operating there. But on Nov. 2, operations were suspended on the whole front S. of the upper Vistula.

During this period; the E. front of E. Prussia had been subjected to attack, as had been expected. Rennenkampf, advancing from Kovno and from Osseviez as well as frontally, had pressed back the VIII. Army (von Schubert; later von François) to Kibarty and to the W. of Lyck. François, outguino in temperament, defending his own corps district, inspired by a personal order from the Kaiser to protect E. Prussian territory, and conscious that the work in the last defence was incomplete, was determined to hold his forward position to the last possible moment. Falkenhayn, objective in mind, and uneasy in spirit, reinforced him with the new XXV. Res. Corps, which retok Lyck and Grayvo, threatening Szawki from the south. The front then became quiet, for the Russians had no serious offensive intention. Their I. Army was already on its way to Warsaw when the German counter-advance took place, and the X. Army left to flank-guard the northern corridor was reduced in strength to 13 divisions, as compared with some 47 in Poland, and 30 from Zawichost to Turka. On the Mlawa front, held by von Zastrow with a Landwehr Corps called the XVII. Res., all was quiet in the period of the Vistula-San operations.

The Campaign of Lodz-Cracow-Lincoln.—The retreat had been foreseen in time for the German IX. Army to make elaborate preparations for delaying the enemy's advance along the south-westerly railway lines by which, evidently, his intention was to reach Upper Silesia and the Moravian gap. In the course of the retreat the demolitions planned as well as the evacuation of stores and supplies, were carried out, if not completely, at any rate sufficiently for their purpose. But both Hindenburg's

and Conrad's headquarters realized that they had now to deal with the full effort of the enemy. The "steam roller," after breakages and delays, had started. By Oct. 31 the German IX. Army had gone back to the line Syeradz-Saczerów, Nowe Radomsk, Wlozczowca, Checiny, the Austro-Hungarian I. Army to Kielce, Opatow, R. Opatowka. On Nov. 1-2 the latter was driven back from the Opatowka line, necessitating the withdrawal of the IV. and III. Armies from the San and the abandonment of the offensives in progress on the E. of the Szary Samber region. A few days later the Russians had again invested Przemysl and were advancing to the Dunajec. The centre of gravity, however, was no longer S. of the Vistula.

The crisis brought out, in the three men who had to deal with it, Conrad, Falkenhayn and Ludendorff, the characteristic quality of each.

Conrad proposed to Falkenhayn that no less than 30 German divisions should be brought over from the W. at once, bringing Hindenburg's strength up to about 53 divisions. Forces in the Carpathians and in E. Prussia were to be economized, and the bulk of the Austro-Hungarian and German Armies were to seek decisive victory in battle in Poland. Now that the Russians had gathered, and gathered so far W., it would be possible to bring this about without fear of their retreating into the limitless interior of their own country. In short, the war could now be won in the E. It could also be lost, but unless some such decision were attempted, Conrad held that it would be necessary to retreat to the Danube. Falkenhayn, on the other hand, was becoming convinced—especially by the experience of Ypres, that the war would be a protracted trial of endurance, and must be handled on the principles adopted by Frederick the Great in the latter part of the Seven Years' War, viz. a wary, economical defensive, with offensive sorties on every favourable opportunity of necessary action, but no striking of all upon a throw.

If Conrad was the foe of the Central Powers, Falkenhayn was their Johnson. Had the Southern Confederacy possessed a Grant, the parallel would be complete, for Ludendorff met the problem as Grant would have met it, by a strategy that was at once objective and grandiose. Hindenburg was now commander-in-chief of the German eastern front, and his headquarters could deal with the situation as a whole. Ludendorff's plan was to transfer the bulk of the IX. Army by the Silesian railways to W. Prussia (Thome-Hohenstaern region), whence by a sudden advance through the north-western part of Poland, he could strike upon the right or right-rear of the enemy's system. To strengthen the offensive mass, the E. front of E. Prussia was to be stripped almost bare of troops; and the country in front of the lakes and the Angerapp deliberately evacuated and broken up. The E. front of E. Prussia (Zastrow's and other formations) was to participate in the offensive by advancing on Plock, Ciechanow and Biazysta, with the mission of flank-guarding the main attack on the E. side of the Vistula, and of keeping the Russian I. Army busy on the axis Mlawa-Ciechanow; and to ensure that these forces should not be drawn away to the E., they were placed directly under General Headquarters. To fill the place of the IX. Army in S. Poland, Woytech's Landwehr Corps was reinforced, and by agreement with Conrad, Böhm Ernólli with the bulk of the Austro-Hungarian II. Army, was brought on rail from the Carpathians to the upper Warta, while to the left of Böhm the 9. Posen, 11. and "Breslau" corps of Ersatz and Landwehr were brought forward on the Kalisz-Sieradz line. To prepare for the worst, arrangements were made for destroying the mines of Upper Silesia. By all these drastic measures, Ludendorff expected to obtain a partial success that would suffice, without at present calling upon Falkenhayn to provide the mass of divisions asked for by Conrad. At the moment at which the plan was put into effect, more was actually possible. The continuance of the retreat, especially on the front of the Austro-Hungarian I. Army which was taking

<sup>1</sup> Von François resigned his command in indignation and was replaced by von Below.

<sup>2</sup> This was the second reserve of Posen. The first, as Bredow's division, was already on the field.



the weight of the Grand Duke's attack on the line Kielce-R. Opátowka, brought the enemy ever nearer to Cracow and Upper Silesia, and the destruction of bridges and railways on the IX. Army front could only have a temporary effect. Moreover, new dangers threatened both the eastern and the southern fronts of E. Prussia.

On Nov. 5, the Austrian I. Army had retired behind the Nida, Zastrow's advanced forces were retiring on Mlawa, Below was preparing to meet a new thrust of the Russian X. Army (Sievers). On the 8th Ludendorff asked Falkenhayn for 6 to 8 more divisions as soon as possible, and for more later. The crisis, and with it the hope of decisive victory, was becoming more acute. On the 10th the regrouping was complete, except in the centre, where Böhm-Ermolli was not yet on the scene. Here, cavalry alone held the country to the N. and N.E. of Kalisch. The Posen and Breslau Corps were beginning their advance from Kalisch and Kempen respectively. Weyrsch (Ldw. Corps, 1st Gd. Res. Div., 35 Res. Div.) was in front of Czesochowa; from Zarki to Wiehna the Austro-Hungarian I. and IV. Armies had fallen back concentrically on Cracow, in front of which they now stood; the XI. Corps covered W. Galicia; the III. Army had taken over the front of Böhm as well as its own and stood on the line Vitepska-Dukla Pass-Ussok Pass, and Pfanzer-Baltin, his offensive suspended, was at Verecz, Okormezzo, S. of Delatyn. R. Pruth. But the offensive group (IX. Army under Gen. Oberst von Mackensen) was ready—the XI. and XVII. Corps outside the Warta where it enters Germany, the XX. at Hohenalza, the I. Res., XXV. Res. and 3rd Gd. Div. between Mohanzala and Thorn.

At that date the Grand Duke's Armies were thus disposed—X. on E. Prussian eastern front, I. (8 divisions) on E. Prussian S. front (Plock to Mlawa), with advanced troops approaching Sedzin, Ryppin and Lipno and one corps S. of the Vistula about Wladawek; II. (6 divisions and a cavalry mass), W. of Lodz, advancing on Kalisch, with the II. Corps between Kutno and Lenczyca as a protective echelon; V. (8 divisions) nearing the Widawka river, cavalry approaching the Upper Warta; IV. (6 divisions) between the Pilica and Jendziszew, pointing towards Beutken; IX. (8 divisions) in the angle of the Nida and the Vistula; XII. following up the Austro-Hungarian retreat towards and beyond the Dumajec, VIII. and Dalester Group on the Carpathian front; XI. (newly formed) besieging Przemysl.

On Nov. 12 the advance of the German IX. Army began. On the 14th at Wladawek, parts of three corps quickly overwhelmed the corps of the Russian I. Army there, and drove it over the Vistula. The next phase was a concentric advance on the Russian II. Corps, right echelon of the II. Army, which held a position from Kutno to Lenczyca; out of this position it was driven with heavy losses on the 15th, losing at Lenczyca the gate between the Bzura and the Ner (Warta) waterlines. Then, while part of the German army pushed forward down the Vistula to intercept any assistance that might come from the I. Army; the XXV. Res. and XX. Corps from Kutno and Lenczyca, with the XVII. and XI. Corps from the Warta valley, advanced on Lodz, the manufacturing centre of Poland.

The battle of Lodz, which began on Nov. 17, is described elsewhere. In its intensity, its vicissitudes and its significance, it was the Ypres of the eastern front. In it took place the epic incident of the break-through, envelopment and final successes of the XXV. Res. Corps and 3rd Guard Division. No battle of the World War shows such varied, involved and difficult tactical situations. Here we are concerned with the results only. From the 19th the Posen Corps and Frommel's cavalry were actively engaged on the left of the XI. Corps, thus connecting the battle of Lodz with the fighting which went on all along the line to Cracow, where the Austro-Hungarian I. and IV. Armies contended without defeat or victory against the thrust of the Russian IV. and IX. Armies. Further E., the Austro-Hungarian XI, Corps and III. Army engaged, equally without decisive results, the Russian III. and VIII. Armies. But Ludendorff had admirably won his "Tellerfolg," for the Russian onset on all parts of the line S. of the Lodz area was partly or wholly

suspended in order to assemble all possible forces for the prevention of disaster on the right wing. Pressure was relaxed also on the two fronts of E. Prussia as the uncommitted reserves of the attack were taken away. In his regrouping the Grand Duke was successful; a continuous line of battle was formed by Dec. 6 from Ilow on the Vistula, W. of Lowicz, E. of Lodz, W. of Petrikow, W. of Nowe Radomsk, and so to the Cracow battle-field. But the cost had been heavy, and the Russians were unable, then or thereafter, to resume the tidal advance on Silesia and Moravia. With the formation of this long continuous line from N.W. of Warsaw to S. of Cracow began a new phase of the struggle, in which the battle of Lodz merges into the battle of Lowicz, and that of Cracow develops, on its southern side, into the battle of Limanova-Lapanow.

It has already been mentioned that Ludendorff had on Nov. 8 asked Falkenhayn for 6 to 8 divisions to be sent at once from the W. and more later. At that date Falkenhayn was still contemplating an attempt to revive the battle of Ypres, and had not reconciled himself to position warfare. On the 16th, before the decision had fallen at Lodz, Falkenhayn in agreeing to send 6 divisions had at the same time expressed his belief that it would even so be impossible to bring Russia to admit defeat, and that the outcome—certainly desirable in itself—would only be to relieve Austria-Hungary by the reconquest of the Vistula-San-Dniester line, and perhaps of Lemberg also. But a wet later, under the influence of Mackensen's victory, he said that success in N. Poland might decide not only the Galician question but the whole war. He thought this might be achieved by building up yet another striking force E. of the Vistula, where the Russian I. Army was continually giving up divisions in the battle of Lodz. Ludendorff, on the contrary, saw no prospects in such a piecemeal building up of strength which the Russians could answer *pari passu*. Power and surprise combined, he held, were essential. At this moment, there were in Germany 9 new divisions under training, but the awful waste of the lives and energy of their predecessors at Ypres had convinced Falkenhayn that it was necessary to avoid cutting short their training and to give them more experienced leaders before committing them to battle. Ludendorff, in spite of the achievement of the XXV. Res. Corps at Lodz, seems to have occurred in this view. Thus the reinforcement reduced itself to a gradual incoming of 8 divisions from the W. (II., III. Res., XIII. and XXIV. Res. Corps) which, with the I. from the now relieved E. Prussian front were all absorbed in the frontal battle about Lodz and Lowicz, save one which was sent to assist the Austrian IV. Army S. of Cracow. The battle of Lowicz began and continued as a front-to-front battle in which each side sought to condense enough force for a blow, now here and now there. It ended, in mid-December, with a general withdrawal of the Russian line to a winter-position, which ran along the Bzura and Rawka to Rawa, and thence southward, crossing the Pilica E. of Tomaszew and following the upper course of that river, 5-15 km. E. of it, till near Jendziszew it reached the Nida, to follow it to the upper Vistula.

South of Cracow, in a country of hills where manoeuvre was possible and open flanks frequent, advance and counter-advance alternated during the month of December. In conforming to the general retirement of the Allied forces in October, the Austrian I. and IV. Armies had gathered about Cracow, and during November they had maintained their front against the Russian IX. Army (battle of Cracow). At the end of the month, however, the enemy had developed a strong attack S. of the Vistula, which reached the line Wyllcza-Sieprent-Drogisia, and threatened by turning the fortress from the S. to make the desired breach for passage into Moravia. This danger was averted by a regrouping of the Austrian IV. Army, which enabled an attack-force to be assembled on the right wing about Mezna Dolina and Dobra, almost in the mountains. On the 3rd this force attacked northward, bringing the Russians' advance at once to a standstill, and forcing them to make new dispositions. The fighting was prolonged and heavy. On Dec. 8, forces of the Russian VIII. Army, condensed on the western flank of that army, be-

gan in turn to attack the flank of the Austrian attack group, which had gained ground northward as far as Lapanow and Rajbrod. At Limanowa, the scene of this flank attack, three dismounted Austrian cavalry divisions had to meet the onslaught of more than an army corps. At the same time, the centre of the Russian III. Army farther N. assumed the offensive again, and threatened at Lapanow, to break the Austrian main body in two. But resistance at Limanowa continued till the Austro-Hungarian III. Army, defending the Carpathians with varying fortune, had managed to assemble a group on its left which struck in on the flank of the Russian forces about Limanowa (Dec. 11). Thereby the battle of Limanowa-Lapanow was decided. A last Russian force which was seeking to reach the flank of this Austrian counter-offensive was itself engaged in flank by other forces of the Austrian III. Army, and the Russians withdrew along the whole W. Galician front to R. Dunajec-Krzostek-Krosno-Lisko (Dec. 14-16). A few days later the Russians launched a fresh offensive which in the battle of Jaslo (Dec. 21-23) drove back the inner flanks of the Austrian III. and IV. Armies to the line Zakliczy on Dunajec-Gorlice-Uscie-Ruske-Konicza, and pressed the front of the former back to some places behind the Carpathian line. Here, and farther E., the operations were entering on the phase known as the Battle of the Carpathians, which will be dealt with later. But from Tilsit to Gorlice, the campaign of 1914 closed in "stabilization."

At this period, according to Falkenhayn, the combatant strengths on both sides were: 105,000 Germans and 320,000 Russians E. of the lower Vistula (E. Prussian fronts); 525,000 Germans and Austrians and 847,000 Russians between the lower and the Upper Vistula; 525,000 Austrians (including 1 German division), and 521,000 Russians between the Upper Vistula and the Rumanian frontier. In sum, 1,155,000 Germans and 1,688,000 Austrians (of whom 502,000 were German-Austrian).

Acknowledgments are due to General Y. Danilov for certain information as to the Russian plan of campaign and strategic deployment.

(C. F. A.)

### III. CAMPAIGN OF JANUARY-SEPTEMBER, 1915

By the third week of December, 1914, the struggle in the central salient had died down to a trench-warfare contest, in which the remaining energy of the troops was devoted to consolidating gains or to preventing the opponent from doing so. The situation of Ypres was reproduced in that of the eastern front at the end of the battle of Lovicz. But there was the important difference that on both flanks there was still room to manoeuvre. On the N. flank, the region of Plock, Allava and Myszyńc was open, and the Russian army's position, in front of the Angerapp and the lakes, reached for the third time as the result of the battle of Rominten Heath (Nov. 13-16), rested its flanks on no very secure obstacles. On the S. flank, the line was continuous from Craçew to the Carpathians, but thence eastward the position was fluid. The Grand Duke, therefore, determined to assert his offensive will and power, and confiding in the hardiness of his men, for whom winter was less terrible than for the enemy, began to group his forces with greater density on the flanks. The first signs of this tendency appeared in the counter-stroke of Jaslo, which nullified the reverse of Limanowa-Lapanow and initiated the battles of the Carpathians. The second consequence was the reinforcement of the X. Army, and the re-formation, under a new army staff (XII.), of an offensive mass on the Narew.

At the outset, in the latter part of Dec. 1914, this new policy seems to have aimed at tactical results only, but in Jan. the offensives maturing on the outer flanks became evidently strategic. Interpreting the experience of the previous campaigns, the Russian headquarters could see not only the insecurity of their northern corridor, which must continue until E. Prussia had been cleared to the Vistula, and the similar but lesser risk to their left flank, but could also judge that the conquest of E. Prussia and the invasion of Hungary would be very heavy blows to the heart of the war-sentiment in Germany and Aus-

tria-Hungary. Reinforcements were constantly coming in, and it seemed that what the Russian headquarters chose to adopt as their plan they could impose upon the enemy. One factor, however, was already causing anxiety, that of munitions. Although the ammunition expenditure on the eastern front was on a much lower scale, both then and thereafter, than that in the W., yet even so it was far greater than had been foreseen; and Russia, with her low industrial development and her difficulties in communication with the outer world, was less well equipped than either her allies or her two opponents to meet the strain. Later, the shortage was to become disastrous and tragic; at present it was an additional argument for transferring operations to those parts of the line where trench warfare had not set in. It was not regarded as a reason for suspending the offensive, but rather for choosing for it those areas where conditions favoured human manoeuvring power.

On the other side, the problem of 1915 was, like those of 1914, viewed differently by the three men concerned, Falkenhayn, Conrad and Ludendorff. The first named, after a moment of enthusiasm in the Lodz period, had returned to his normal method of conducting the war as a war of endurance, with limitations on particular acts of it. One of those limitations in the present instance was the necessity sooner or later of opening a way to Turkey by seizing at least part of Serbia. Another, and the principal, was the necessity of holding firm on the western front. German strategy was now paying the penalty for having doubled its fighting front there by bringing in Belgian territory. Throughout 1915, the year in which Russia was the principal theatre, just as in 1914 when it was only secondary, we find Falkenhayn working with extremely narrow margins of free strength. At a time when Germany alone possessed some 160 to 170 divisions, the adoption or rejection of operative schemes of the highest importance was made to depend on availability, or otherwise, of four, six or ten of them. Yet there was no remedy for this, short of a considerable surrender of occupied territory in the W.; and in the war of endurance, as conceived by the Falkenhayn school, occupied territory is an asset not to be sacrificed for the sake of a showy, but indecisive, tactical victory. The principle of working from situation to situation was, with Falkenhayn, fundamental, and in the winter of 1914-5 his projects in the east did not go beyond the formation of a German "South Army" under General von Linsingen to aid the Austrians in the Carpathian struggle. In this the motive was direct stiffening and not manoeuvre—in fact, only half of this army (4 divisions) was German. To find these divisions, the German chief had to postpone *sine die* his Serbian project, to which he attached very great importance; but the condition of the Austro-Hungarian army in the bitter winter fighting of the Carpathians left him no alternative, especially as the prevention of a Russian break-through into Hungary was a condition precedent of any Danube operation.

Conrad von Hötendorf, for his part, was sanguine as ever, and the plight of Przemysl—undergoing its second and more terrible siege—continually spurred him to activity. While meeting, with local counter-offensives, the growing Russian pressure on the Carpathian front, he proposed, first an offensive in the centre of the Polish salient on Radom (scarcely a promising direction), and then a resumption of the old scheme of an Austrian and Prussian rendezvous near Siedlce. Neither was accepted by Falkenhayn, and Conrad then proposed the direct relief of Przemysl by means of a great offensive from the Carpathian line. It was for this offensive and this purpose that the German South Army was formed and, later, Böhm Ermollo's II. Army brought back from Poland. Substantially, then, Conrad, unlike Falkenhayn, was eager for battle as such. But, like Falkenhayn, he had no manoeuvre—in the true sense of the word—to propose, that was in the given conditions practicable and worth the supreme effort.

At Field-Marshal von Hindenburg's headquarters, on the other hand, the idea of manoeuvre was always uppermost. Its basis was the fixed conviction that it was possible not merely to tame but to destroy Russia's fighting power on the field of battle.

To achieve this result against superior numbers, manoeuvre was the only way, and by the term "manoeuvre" Ludendorff understood the preparation and sudden delivery of a destructive blow by locally superior force upon that part of the enemy's system which was the key of the whole. In the present case, this key position, Ludendorff held, was the Russian X. Army in the foreground of the Masurian lakes. In this quarter, and also between Malva and Myszyńiec, Russian offensives were maturing as early as mid-Jan., and in any case Hindenburg's headquarters had to consider the question of a preventive offensive in E. or W. Prussia or both. But the operative aim became higher as soon as it was known that Conrad meant to attempt the relief of Przemyśl by winning through to the San and the Dniester. The four new army corps completing their training in Germany were asked for, for the purpose of a winter offensive which should not only anticipate that of the enemy, but also, in conjunction with Conrad's effort, "decide the whole war." These four corps (XXXVIII.-XLI. Res.) were Falkenhayn's cherished reserve, with which he meant to parry any great crisis that might arise out of the "Winter Battle of Champagne" then in progress, and himself to attempt a decisive offensive in France.<sup>1</sup> From the contemplated blow in Prussia he expected no more than the temporary and local disablement of the enemy, so that he did not think it necessary to coördinate the effort closely in date or direction with Conrad's advance. Nevertheless, "with a heavy heart," as he says, he surrendered the four corps to the east, though at first—till the Champagne crisis cleared in March—he reserved the right to withdraw them again. Actually, the XXI. Active Corps of Alsace-Lorrainers was sent from the French front, the XLI. Res. Corps taking its place there; the other three, with the XXI., went to E. Prussia at the end of Jan. and constituted the new X. Army (General-Oberst von Eichhorn).

The two operations with which the campaign of 1915 began in the W. were not, in the strict sense, coördinated, though their combined effect, owing to geographical conditions, was expected to be the destruction, according to Ludendorff, or the prolonged paralysis according to Falkenhayn, of Russia's offensive power.

*The Carpathian Winter Battles.*—Owing to the relatively low development of Hungarian lateral railways—the Galician laterals were in the hands of the Russians—it was not feasible for Conrad to form a really important offensive mass in the eastern Carpathians and the Bukovina, as Hindenburg did in the region of the Masurian lakes, without great loss of time. The struggle therefore resolved itself into surgings of frontally-opposed tides, the one seeking to break into the Hungarian plain, the other to rescue Przemyśl. Although, the lines being for the most part discontinuous, tactical and local outflanking efforts, for the time and place decisive, were constantly made by both sides, there was no systematic attempt at strategic envelopment on either. At one moment indeed (Feb. 20), Pflanzer-Baltin's army group, victorious in Bukovina, sought to wheel in on the rear of the battle-field of the German South Army; and at a later stage the Russian Dniester forces were heavily reinforced for the purpose of driving Pflanzer-Baltin away and so gaining the flank of Linsingen. But in the main the opposed tides affronted each other and were broken, each in turn. In W. Galicia, the Russian offensive of Jasło came to a standstill in the first days of January, and for the next three months nothing of importance took place W. of Gorlice. Here the Russian III. Army (Radko Dimitriev) and the Austro-Hungarian IV. Army (Archduke Josef Ferdinand) were opposed. In the middle Carpathians, where Brusilov's VIII. Army was opposed by Borojević's III. Army and by the left wing of the widespread Pflanzer-Baltin group, the year opened with the evacuation by the defenders of the important Uszok Pass, under a local threat of envelopment. The Dukla Pass and the adjacent mountain region had already been lost, and from the Uszok the withdrawal spread east to the

Volocz and Wyszok Passes. In the eastern Carpathians and Bukovina the Russian Dniester group (Webel) pushed back the light forces which Pflanzer-Baltin had in the foreground of the mountains, but in the last week of Jan. the arrival of the Austrian XIII. Corps from Serbia gave Pflanzer-Baltin enough forces to enable him on the 31st to begin the reconquest of the lost ground. Meanwhile, the right of Borojević's III. Army had held on, in spite of the loss of the Uszok and the Dukla Passes, and it was now reinforced. After covering the assembly of the German South Army about Munkacs, this wing was to constitute the striking force of Conrad's offensive for the relief of Przemyśl, the South Army (including Hofmann's Austrian Corps facing the Volocz Pass) following it in echelon on the right.

The offensive began on Jan. 23, and as usual in this part of the eastern theatre, met at first only light forces of the Russians. The whole Austrian line, from E. of the Dukla to the Wyszok Pass, moved forward, the left wing of Pflanzer-Baltin conforming. The Uszok, Volocz and Wyszok passes were retaken by the South Army, and Borojević's striking force reached and passed the upper San (line Czeremcha-Baligród-Lutowiska-Borynia-Smorze) by Jan. 31. But the Russians had already answered by accelerating their projected offensive against the centre and left of Borojević (front Mezłaborcz-Koniczna) and especially southward and south-westward from the Dukla. From this point the battle was a contest of will-power and manpower. The inactive fronts were stripped of more and more divisions. Early in Feb. Böhm-Ermolli's headquarters returned from Poland to their old place on the right of the III. Army (front Lupkow Pass-Uszok Pass), and on the other side Letchitsky's IX. Army headquarters were withdrawn from the Niśa for the Dniester theatre. Between the end of January and the end of April the strength of the opposed forces in Poland west of the Vistula were approximately halved. In the event the Grand Duke Nicholas not only succeeded, during the first three weeks of Feb., in checking (and in forcing back somewhat) the Austrians on the Upper San; but considerably enlarged his gains S. and S.W. of the Dukla Pass, taking Mezłaborcz and the Lupkow Pass, and penetrating the Laborcz and Ondava valleys. On the other hand the German South Army made its way forward, very slowly, astride the Munkacs-Stryi railway.

Further E., the counter-offensive campaign of Pflanzer-Baltin, begun on Jan. 31, was successful in clearing all Bukovina and the Carpathian foreground as far as the Pruth on the right and the Dniester in the centre, but its left, attempting to intervene in the rear of Linsingen's opponents, was involved in heavy fighting about Krasna on the Lomnica, and in the last week of Feb. the heavy counter-attacks of the assembling Russian IX. Army drove the centre from its forward position on the Dniester. By mid-March, Pflanzer-Baltin had been forced back still farther to a line marked by the upper Lomnica-Solotvina (on the Bistrica)-Czermelica-Horodenska-Snyatin-Czernowitz, on which operations came to a standstill. These operations were however of secondary importance in which only some 10% of the whole forces of each side were concerned.

The real crisis, which culminated in March, was on the front between the upper San and the head of the Ondava valley, N.E. of Bartfeld (Bartfa). As in Feb., the right of the Austrians sought to force a way to Przemyśl—now in extremity—and the right of the Russians to enlarge the bridge-head in front of the Dukla and Lupkow Passes. The fighting was again intense, for the Austro-Hungarian II. Army had been reinforced for a last effort; but in the maid its advance on Przemyśl was definitely stayed by the middle of the month, while the Russians in the Dukla region made continuous, if slow, progress. The German South Army progressed along the railway to Tuchla, but at this stage of the battle its advance had not and could not have any great result, and its left was held up for weeks before the strong positions known as Zwinin and Ostry, covering Koziova. Finally, on March 20, sure of the imminent surrender of Przemyśl (which in fact fell on the 23rd) the Russians launched all along the front of the Austrian III. Army new attacks which, fed by troops released from the blockade of Przemyśl, drove that

<sup>1</sup> The German contingent of the South Army had been formed from local reserves already in the east. Its staff was formed from that of the II. Corps.

army back to the line S. of Zboró-Kurlima-Szizopko-S. of Virava-Wola Michowa. At the same time Böhm's forces on the upper San front were compelled to fall back to the starting line of Jan. 23, whence they were withdrawn, in a state of exhaustion, to a line generally behind the mountain crest. The right, still in front of the recaptured Uszok Pass, was transferred to the control of the South Army.

Three weeks longer the battle lasted, but without material change, though both sides were 110,000 to 120,000 stronger in combatants than they had been in January. In the area of the Austrian III. Army two fresh German divisions, grouped as the "Beskiden Corps," arrived to stiffen the defence. In its new positions the Austrian II. Army held its own. The South Army maintained its ground also from N. of the Uszok Pass to Tuchla, and stormed at last the positions of the *Zwiazia* (April 9) and *Ostry* (April 25) and *Koziowa*. To the E., *Pilanzcr-Baltin's* fighting wing and centre, reinforced by German mounted troops, regained its positions on the *Dniester* and held off a new attack which *Lechitzky* mounted against its outer flank between *Czernowitz* and *Usclebskapece* on the *Dniester*. By April 20, however, the Battle of the Carpathians was at an end, after three months of continuous mountain fighting, in temperatures sometimes as low as -22 deg. F.

The apparent effect of these battles was to give the Russians more secure possession of a bridge-head S. and S.W. of the *Dukia Pass* which they could not use, and to waste the remaining war-energy of the Austro-Hungarian army in attempting to relieve a fortress which certainly contained fewer men than the number sacrificed in the attempt. But in reality the indirect consequences of the battle were of much greater importance than the direct. In the Carpathians, no less than in the *Masurian winter battle* presently to be described, the Central Powers had managed to snatch the initiative before the Russian offensives had got under way, and thus put back the date and place of those offensives so far that the break-through into Hungary proved impossible. For the third time the "steam roller" had been brought to a standstill. Moreover it was showing signs of wear. Manpower had been unsparingly expended by the Russian command in its determination to break through; the trained officers and under-officers of peace-time were reduced to a skeleton, and the supply of munitions and even arms was becoming a very grave problem. In the majority of cases, it had been the Russians who attacked and the Austrians who defended the strong mountain and hill positions, and, though specific figures are not known, all the evidence available points to the Russian losses having been far greater than those of the Austrians and Germans. In sum, the Russians needed a pause even more than their opponents.

*The Masurian Winter Battle and the First Battle of Przemysl.*—The plan of campaign formed by Ludendorff for E. Prussia, as already mentioned, seemed higher than the simple preventive-offensive for which Falkenhayn had lent "the four new army corps. His line of standing, differing from Falkenhayn's, was, and remained; this:—the war will be decided by military victory in the W.; but this victory will not be possible till after the definitive defeat of Russia, because the degree of numerical and material superiority required for the double task of breaking through the strong trench-system of the W. and exploiting the break-through in an open-field campaign was not attainable till Germany could devote practically every battle-worthy man and gun she possessed to the western theatre. Meantime, nothing was gained and much lost by using up reserves in repetitions of the battle of Ypres. Whether, in Feb. 1915, the time was ripe for such a blow as Ludendorff contemplated is however more doubtful. Both on the *Mlava-Myseyniac* front and on the E. front of E. Prussia the Russians were well in advance of the natural barriers protecting the southern corridor. Victory W. and N. of those barriers could only lead to a limited exploitation unless the barriers could themselves be carried in the tactical pursuit. Victory on the barriers themselves, on the contrary, would give an unlimited field for strategic exploitation inside them. In the situation of Feb. 1915, then, an effort to inflict a completely disastrous defeat on the Russians required two successive efforts,

or successive maxima in a continued effort; hence a double allotment of force would have to be made. A large part of the required divisions could have been found from the army reserves of the central salient, or by thinning the line itself there, had it not been for the formation of the German "South Army," which, raising the number of divisions absorbed in the Austro-Hungarian front from 1 to 5, left only limited possibilities of drawing on the IX. Army and *Weyrsch*, for the benefit of the E. Prussian Army, which ever since Nov. had been on a very low footing. *Weyrsch* and *Mackensen* were in fact able to provide six free divisions. For the rest, if nothing could be spared from France, the eight new divisions were the only available reinforcement. Hence Falkenhayn's well-founded scepticism as to the scope of the E. Prussian offensive, and hence also Ludendorff's regret, after the event, at having parted with so much of his local reserves for the bolstering-up of a Carpathian attack.

The secret augmentation of the E. Prussian forces from the figure of 10 divisions (8 of which were *Landwehr* and *Ersatz*) in mid-Jan. to that of 24 in the first week of Feb. was itself no small task, and had it not been for a very fierce diversionary attack by the IX. Army at *Bolimow*, in the angle of *Baura* and *Rawka*, on Jan. 31-Feb. 2—memorable as the first occasion on which gas-shell were employed on a large scale—it is doubtful whether it would have been accomplished, for the assembly had to be made under cover of a thin screen of mounted troops, and by hypothesis the opponent himself was preparing to attack. The plan itself was comprehensive, and suggests that Ludendorff had not given up hope of being able to extract more divisions from Falkenhayn. It consisted in three main elements:—(1) the destruction, by means of breaking through and envelopment combined, of all enemy forces lying between *Lyck* and *Tilsit*, (2) the attempt to carry the *Bobr* line with a rush so as to break into the "corridor" south of *Grodno*, and (3) an advance on the *Mlava-Wilkenberg* front, in conjunction with (2), so as to bind the Russian I. Army while the X. was being destroyed and the *Bobr* forced.

The German forces were divided into three armies:—the VIII. (Otto v. Below) of 7 divisions (including one of the new corps), which, after covering the whole eastern front during the assembly was to form an attack front on its right wing (*Johannisburg*); the X. (v. *Eichhorn*) of 7½ divisions, including the XXI. active and the other two new Reserve Corps assembled between the *Niemen* and the *Lakes*; and the Army Group *Gallwitz*, ten divisions, of which six came from central Poland, holding the southern front from the *Ozryc* to the lower *Vistula*. The scheme of the German offensive, though it was to be carried out over much the same ground as the September battle, differed considerably from the plan of that battle. The winter trench-line represented the halt of the Russians after the *Rominen Heath* battle, in front of the *Lakes-Angerapp* barrier. It ran N. to S. from the *Schordellen* Forest by *Darkehna*, B. of *Litzten* to W. of *Johannisburg*, where it began to curve away to join the southern front. The right wing therefore presented to the Germans better chances of envelopment than *Rennau-kampf's* right had shown in Sept., and it was on this flank that Ludendorff meant to make the chief effort. But the most significant difference was that it was now intended to treat the attack on the Russian S. flank as a break-through and not an envelopment problem. For this reason, not only was an attack group formed behind *Lake Spirding* but von *Gallwitz*, guarding the S. front, was to occupy the Russians on the *Narew* and prevent them from assembling large forces against the S. side of the VIII. Army attack. Moreover the attack was to aim at seizing crossings of the *Bobr* at and near *Osowiec*. Tactical cooperation in the enticement of the Russian forces north of *Lyck* was the primary but by no means the principal task of the VIII. Army's attack group. If the power and speed of the X. Army's blow from the N. proved as great as was hoped, the exact position of the anvil on which it crushed the Russians was of secondary importance compared with the seizure of *Osowiec* and the *Bobr* by brusque attack in the *Liège* manner. On this, and on the progress made by the XXX. Corps (*Gallwitz's* left) by *Myszyniec*, on

Lomża, would depend the strategic, as against the tactical results of the whole enterprise.

The "Winter Battle of Masuria" therefore may be regarded, if not as the first great battle of the latter-day type, at any rate as in a transitional style. Although an open flank existed and was utilized to produce the tactical envelopment or "Cannae" of pre-war theory, yet the effective victory was intended to be gained from a break-through, tactically difficult, but aimed in a strategically favourable direction.

The attack of the VIII. Army began on Feb. 7, that of the X. Army on Feb. 8, in the midst of snowstorms which, during the battle, changed to rain—the worst conditions for the carrying out of the scheme and notably its strategic part, which depended on the marshes of the Bobr being frozen hard. In sum; the X. Army drove the Russians southward without intermission from the first day. By the 10th the northern portion of the Russian line was being taken down with all speed, and by the 12th the German X. Army stood on a line from Ludwinow to Reininten Heath at right angles to the VIII. Flank guards were put out toward Pilwiszki and Mariampol against intervention from Kovno, but neither then nor later did anything more serious than threats by light forces develop on that side. Meantime, however, the VIII. Army's attack (XL Res. Corps and parts of the I. Corps) from Johannsburg Heath and Lötzen on Lyck was brought to a standstill in front of Lyck by the fierce resistance of the III. Siberian Corps, which not only suspended the advance eastward, but led the German forces that were to the S. of it to swing north-eastward on Rajgrad so as to envelop the Lyck position. The expected Russian counter-attacks from Lomża and Osowiec proved too feeble—being absorbed chiefly by the advance of a division of the XX. Corps farther W.—to interfere seriously with this tactical manoeuvre. But thenceforward the Osowiec portion of Ludendorff's scheme was doomed. The battle became the purely tactical "Cannae." As such, it was brilliantly successful. By Feb. 14 Lyck had fallen and the VIII. and X. Armies had made good a semicircular position from Rajgrad, by Racaki and Seyny to the N.E. corner of Augustow forest. In the forest the Russians (no longer able, for want of routes, to withdraw with speed) fought with desperation to gain time for orderly withdrawal to Grodno, the one remaining avenue of escape. But by the 18th, forces of the XL Res. Corps from Rajgrad reached the Bobr about Krasnybor, and, on the other wing, part of the XXI. Corps from E. of Seyny drove down at all risks, parallel with the Niemen and within range of the guns of Grodno, to Lipsk, thus closing the ring round four Russian divisions left in the forest. In this extraordinary situation, the German X. Army slowly completed the destruction of the encircled Russians, who resisted for several days and made fierce efforts to break the ring, while small German forces, fighting back to back with the encircling troops, held off relief attacks from Grodno and the Bobr. Finally—but some days too late for the realization of Ludendorff's plan—the remnant of the four divisions in the forest surrendered. In all, this astonishing victory gave the Germans 20,000 prisoners, over 300 guns, and a vast quantity of stores which the Russians could ill spare.

Even before the end, Ludendorff had attempted to extricate enough forces from the W. and N.W. portions of the ring to form the attack on Osowiec and the Bobr. He reconstituted the management of the mixed-up armies as best he could by putting all forces W. of Augustowo under Below (including the XX. Corps) and all engaged in and N. of the forest of Augustowo under Eichhorn. But most of the troops destined for this were involved in the forest battle, and the Osowiec groups had to be made up chiefly out of the troops that had been crowded out of the line as the wings converged. Of the XX. Corps only one division was available, and this had advanced no farther S.E. than Stawiski and Lipniki since it moved from its concentration area three weeks before. The other division was engaged on the Omulew river, and was connected to Lipniki by a thin screen of Landsturm. In sum, it was impossible with exhausted and scattered troops to force the now sodden marsh-valley of the

Bobr or to reduce Osowiec. Hindenburg therefore ordered the attacks to be discontinued.

Moreover, the position of the X. Army, far ahead of regular supplies, had become untenable, and as soon as the battlefield had been cleared it began to withdraw, just in time to secure good conditions for meeting a Russian counter-offensive from Grodno and Olita. There the Grand Duke, "by stamping his foot on the ground"—as it seemed to his opponents—had called into being a new X. Army.

This counter-offensive penetrated through the Augustow forest, almost to Augustowo, and, to the N. of the forest zone, it reached and passed Seyny and Simno (March 5-7). But, thinking that at Simno it had found the flank of the German defence—i.e. miscalculating the promptness of the German decision to regroup on a rear line—the Simno force swung in to the S.E. toward Łozdzieje (March 8), exposed its own open flank to counter-attack from Eichhorn's left, which stood between Simno and Kalwarja, and on March 9 fell upon the flank and rear of the Russians, at the same time as the frontal defence and north of the forest turned to counter-attack. The Russian thereupon withdrew behind the Niemen again. The German X. Army now returned to its prepared line Augustowo-Krasnybor-Kalwarja-Mariampol-Pilwiszki-Szaki.

But the real crisis of the second half of Feb., which lasted till mid-March, lay not on the Niemen, but on the front of the new German VIII. Army and more particularly on that of Galiw. Here with his XII. Army (Plehwé) the Grand Duke had at long intended to make the main effort of his Russian offensive, as geographically dictated; and the advances of Galiw and of the German XX. Corps, as diversions and flankings for the Masurian battle, had merely put back the Russian preparations in time and place. Anger at the disaster to the X. Army, and fears for the safety of the "corridor" at its sensitive point N.E. of Osowiec, caused the Grand Duke to divert forces from the XII. Army to form the new X., but without affecting the mission of that army, which accordingly took the offensive against Galiwitz about the same time as the struggle in Augustowo forest came to an end. At the same date the attempts of the German VIII. Army against Osowiec and the Bobr line were dying out, and the division of the XX. Corp north of Lomża was pinned by heavy counter-attacks from that place, while the other division of that corps was making head on the Omulew against similar efforts from Ostrolenka, and the Landsturm screen between them was holding its ground with difficulty against other attacks from Novogrod. The crisis, from the German point of view, was so grave that even in Ludendorff's memoirs, written four years after the event, satisfaction in the "Cannae" of Augustowo is almost completely smothered in the remembrance of anxieties, makeshift reinforcements, and critical decisions concerning the S. front. All energy on both sides was now focussed on this front.

In the winter of 1914-5, light forces of the Germans had been advanced, originally as an element of the battle of Lodz, a considerable distance S. of Strassburg and Mława, and the reinforcement of these troops to the strength of an army group had taken place on this forward line. Galiwitz had then advanced, in conjunction with the Masurian offensive, deep into the concentration zone of the Russian XII. Army (Feb. 13). In a few days he had reached the line Plock-Racina-Prasnyss. But by about the 24th, Plehwé's interrupted concentration was sufficiently near completion for him to advance. Pressing the front of Galiwitz on each main route, he developed his greatest strength in the Orzye and Omulew valleys. In the latter, the division of the German XX. Corps above mentioned engaged the Russian advance in a series of combats which in the event were undecided; but in the Orzye region the Russian blow upon Prasnyss succeeded in driving back three divisions under v. Morgen (I. Res. Corps) with very heavy losses (Feb. 25-27). The whole centre and left of the German line then fell back, pursued by the Russians, to the line Radzonow-Mława-Choszcz. On and about this line fighting remained severe till about March 19, kept alive on the German side by successive advances

ments from the X. Army, and by assumption of responsibility for the Omskew front by the VIII. Army, which enabled Gallwitz to group his forces more closely on the Chorzele and Miawa fronts.

The crisis died away in local attacks in the latter half of March. The Russians were becoming weak in munitions; the Germans continued weak in men. The last fluctuations of the battle brought the Germans from Chorzele close up to Przasaysa.

Thus the E. Russian offensive of the Russians closed, in the same way as the Carpathian offensive was soon to close, with little gain and great loss of leaders and of irreplaceable ammunition. The Germans, on the other hand, like the Austrians, had failed to achieve their strategic purpose. The general results were thus, for both sides, negative, in spite of the accomplished "Cannae" in Masuria—itsself an exhausting effort.

*Intentions and Plans for the Summer Campaign.*—On both Prussian and Galician fronts a pause of some weeks was imposed by the weariness of both sides. The latter part of March and early April in the N., and the last half of April in the S. were devoted to discussion and formation of plans. At this stage the distribution of force was, according to an Austrian headquarters *East of April 20*, as follows, in rifles and carbines:—

*East Prussian fronts:* 263,000 Germans of X., VIII., and Gallwitz Armies, and 508,000 Russians of the X. and XII. Armies. Frontage 380 km.

*Central salient:* 245,000 Germans and Austrians of IX., Woyrsch, and Austro-Hungarian I. Armies, and 436,000 Russians of the II., I, V., and IV. Armies. Frontage 275 km.

*Upper Vistula to Beskidengebirge:* 108,000 Austrians (IV. Army) and 100,000 Russians (III. Army). Frontage 110 km.

*Carpathians and Bukovina:* 385,000 Austrians and Germans (III., II., S. Army, Pfanzner-Baltin) and 496,000 Russians (VIII., XI., and IX. Armies). Frontage 387 km.

In sum, there were 1,002,000 Germans and Austrians to 1,540,000 Russians.

According to the distribution table given by Falkenhayn for the end of that month, 366,000 German combatants faced 640,000 Russians between the Baltic and the Vistula; 184,000 Germans and 54,000 Austrians, in all 238,000, were opposed to 407,000 Russians in the Polish salient; and 89,000 Germans and 610,000 Austrians, total 699,000, stood on the W. Galicia, Carpathian and Bukovina fronts against 720,000 Russians. In sum, 1,302,000 soldiers of the Central Powers to 1,767,000 Russians. The difference between the two sets of figures is partly accounted for by the fact that artillery personnel is included in the second and not in the first set; but whether taken separately or together, the figures throw a strong light on the state of the Russian army on the verge of the tremendous campaign of summer, 1915. It will be noticed that the total of 1,767,000 combatants is approximately the same as the mean monthly strength with the colours in peace (1,700,000). At this period, no considerable forces were maintained in any but the eastern European theatre, so that, in effect, practically the whole of Russia's resources in men had been absorbed in maintaining the formations existing in peace and some 35 reserve divisions created on mobilization.

It will be noticed also that under the imperative needs created by the two-front war the German forces in the East had trebled, as compared with the strength at the time of the Masurian lakes battle in Sept., but that the Austro-Hungarian forces, though far above the nominal figure of Sept. 1914, were well below their mobilization figure. Hitherto, it must be remembered, the policy of "winning the war in the East" had not been accepted by Falkenhayn; and the German increases represented simply defensive and counter-attack requirements, and in particular the relief of pressure on the Austro-Hungarian armies. Correspondingly, German ideas and execution began from this date to predominate over Austrian. But no effective united command was ever created. German interferences in Austrian operations and operative methods, imperatively necessary to the common cause, but very often tactless, were constantly resented by Conrad and by most Austrian leaders; and moreover great divergencies of policy developed between the two imperial Governments in respect of Poland, Italy, and the Balkans.

Falkenhayn neither then nor thereafter accepted the principle that a decision could be obtained in the East. But his ideas had undergone a change since he conceded the eight new divisions to the eastern theatre "on loan." The French attempt to break through the Champagne lines had failed. A large number of German divisions were being reorganized on the basis of three infantry regiments instead of four, and the forces thus obtained were grouped in new handy divisions of veteran troops, which gave greater freedom in the play of reserves. He had abandoned, after detailed study, his Jan. prospect of a break-through on the Albert-Arras front, and therewith all offensive plans in the western theatre, while Conrad had refused to agree to his renewed proposal to force a way through Serbia for munitions for Turkey, though the peril of a Dardanelles break-through was becoming more and more evident. On the other hand, indices collected both on the Carpathian and Prussian fronts pointed to a growing shortage of material on the Russian side, as well as to a decrease of efficiency owing to losses in leaders and pre-war soldiers. Falkenhayn further thought it possible to keep both Italy and Rumania neutral, at least for a long time. All things considered, he came to regard a very heavy blow on the Russian front as necessary, possible, and desirable; and on Conrad's reviving, on April 7, the old scheme of combining blows from the lower Saa, and from the S. front of E. Prussia, with a rendezvous near Siedle, he agreed, not indeed as to the plan, but as to the principle. It was still only a "sufficiently" heavy blow that he intended to deliver, but the limitation implied in the adverb was considerably relaxed. Eight divisions (Guard and X. Corps, XLI. Res. Corps, and two of the new divisions) were to be brought over from the western front, this time simultaneously, and for use as an army. Of this army (XI.) Mackensen was appointed chief, with Colonel v. Secklt as his chief of staff, Prince Leopold of Bavaria succeeding Mackensen at the head of the IX. Army. To cover the withdrawal from the W., sharp local actions were initiated at different points on the trench-line. One of these, involving ten or more divisions, is known to history as the Second Battle or "gas attack" of Ypres.

The theatre of Mackensen's operations was to be the country between the upper Vistula and the mountains (Dunajec-Gorlice-Tarnow), where the front of contact was in much the same position as it had been at the end of the battle of Jaslo. It was held by the Russian III. Army (Radko Dimitriev) on the one side and by the Austro-Hungarian IV. Army (Joseph Ferdinand) on the other, both being relatively weak. Supposing surprise to be effected, a mass of eight first-class divisions, supported by the troops already on the front and by artillery on a scale never before seen in the East, had every prospect of breaking through. Falkenhayn took many precautions to secure his surprise, and in the main with success, although the Russians and their Allies were well aware that a blow was impending at some point of the eastern front. The troop trains were sent by roundabout routes, false rumours were circulated, and Conrad himself was not informed of Falkenhayn's decision till the movements of concentration had begun. Hindenburg, whose jurisdiction only extended to the left of Woyrsch's line, was instructed to make demonstrative attacks at different points. One of these, the raid of v. Lauenstein's group into Courland, had an important sequel, and will be discussed later. The significance of the other two, an attack at Suwalki by the X. Army and a gas attack near Skiermiewice by the IX. Army, was only momentary. In direction the attack was partly frontal, and it has been criticized for that reason. But a prime factor was the necessity of relieving the situation for the Austrians on the Carpathian front as soon as possible; and, besides in all probability compelling the Russians to retire in the southern part of the central salient, a drive N.E. and E. from the front Gorlice-Tarnow would make the Russian positions in the Carpathians untenable at least as far as the Lupkow pass inclusive. Falkenhayn went further, and proposed to involve the Russians even more thoroughly in mountain difficulties by retiring the right of the III., and the II. and South Armies. To this, however, Conrad would not agree; and Mackensen's blow, lost part of its effect through this refusal.



*The Dunajec-San Operation.*—Reinforced by the Austrian VI. Corps already on the front, and placed in general charge of the Austrian IV. Army as well as of his own, Mackensen was himself subordinated to Conrad's headquarters, though in fact no major decision could be taken without Falkenhayn's agreement. On the Nida front the Austrian I. Army, and in the Beskidensbirge the Austrian III. Army, stood on the flanks of the two attack armies, and in case of success would be carried along as supports. On May 1 (see DUNAJEC-SAN, BATTLES OF) Mackensen's artillery preparation began. The scale of artillery and trench-mortar strength—hardly higher than that of a quiet sector in France in 1918—was, for the East and for 1915, overwhelming. At night, as a final diversion, an Austrian division crossed the Dunajec a little above its mouth and established two bridge-heads. On May 2 Mackensen's attack was launched between Woynick on the Dunajec and Malastov (S.-S.E. of Gorlice). The troops of Radko Dimitriev gave ground, fighting stubbornly. By the 6th they had retired with heavy losses beyond the Wisloka; and the Austrian III. Army, taking up the attack in échelon rightward, had regained the Dukla Pass. By the 9th Mackensen had forced the Wisloka, Borowic was at the evacuated Lupkow Pass, and even Linsingen's left was advancing. On the 11th, on the other flank, the Russian IV. Army evacuated the Nida position, pivoting on Kielce. Operations were fluid, and it was Falkenhayn's and Conrad's problem to maintain them so.

Falkenhayn's intention was to ensure this by making the operation continue as a tactical one, with as little regrouping as possible outside the limits of the battle that was in being. For this reason he rejected a proposal of Conrad to reinforce, at Mackensen's expense, the Pflanzler-Baltin group (now called VII. Army), which by reason of its position might be enabled thereby to reach the rear of the Russian southern wing. He ignored the relief offensives started by his opponent against the front of Pflanzler-Baltin and elsewhere, and he even sought to utilize the attack upon Pflanzler-Baltin as a means of setting in motion the German South Army and the still stable portion of the Carpathian front, E. of the Lupkow Pass. But at first he had no intention that the effort should go in the slightest beyond its tactical limit, which he fixed as the San-Dniester barrier. Conrad agreed. Both leaders were anxious to disengage large forces for use against Serbia or Italy or both.

As foreseen, the rush of the Gorlice offensive came to a stand on the San-Wissnia line. The Grand Duke had, under cover of his relief offensives, collected adequate forces on the III. Army front and was prepared to hold it firmly. By the 14th Mackensen had taken a total of 140,000 prisoners and more than 100 guns, and had reached the line Tarnobrzeg on Wisluta (link with Opatowka line)—Nisko on San-Sieniawa (Austrian IV. Army); Sieniawa-Jaroslaw-Radymno (XI. Army); Magiera and Chyrow region (III. Army); Stry-Sambor (II. Army). But along the lower San, in the bridge-heads of Jaroslaw and Radymno and the fortress of Przemysl, the Russians were ready to fight again, on the alert, in prepared positions, and had by demolitions of all sorts made the supply problem difficult for the Germans and Austrians. At that date Brusilov's VIII. Army and Shtcherbachev's XI. on its left were intact; Saurmay's and the left of Linsingen's were only beginning to advance; while Pflanzler-Baltin was on the defensive along the Pruth except at Kolomea where he still held a bridge-head. Moreover, Italy was on the point of declaring war (as she did on the 24th) and Rumania's intentions were impenetrable. On the western front, the French and British had opened their relief offensives of May 9 (battles of Carency and Festubert). The Dardanelles was under military as well as naval attack, and the Turkish and Balkan problems, always obscure, had thereby become acute as well.

Nevertheless, during the fourth week of May, Falkenhayn finally determined to carry on the Galléian offensive and even to extend it. It appeared, from Mackensen's reports, that the shortage of munitions on the Russian side, already observed here and there, was general, and that it was possible in consequence to keep the offensive alive till it had secured a decision "sufficient for our purposes," in Falkenhayn's own words. Fresh

troops were drawn from the West—in spite of the extraordinary Arras. Hindenburg was invited to press the advance of Woytsch's army group—which had already begun on the 22th to move forward on the left of the Austrian I. Army and was in front of Radom by the 17th—up to the Wisluta below the San confluence. As in the Wisluta-San operation of October 1914, the threat of turning the San line by Josefow was thought to be an effective means of weakening it against frontal attack. Ludendorff, however, declared this operation to be impossible, in spite of the offer of fresh divisions—his mind was already set upon a more grandiose scheme. Falkenhayn thereupon gave the incoming divisions (2½ from France and 2 from Poland) to Mackensen, and on June 3 that general received instructions to push the XI. and IV. Armies over the San barrier, south of the Tanczy, in cooperation with an eastern advance of the Austrian II. Army (now comprising what was left of the III. after Borowic's departure for Italy), which should "finally" beat the enemy still remaining south of the Dniester in front of the South and VII. Armies. Hindenburg was merely "to take any chance that offered him anywhere of profiting by the enemy's shortage of munitions." In sum, then, the scheme was simply a prolongation of the Gorlice-Tarnow effort by means of a fresh engagement of reserves. No new operative idea was involved. But the decision to continue the battle was in itself an operative decision of the first importance, and, in view of the general war situation, a very bold one.

Mackensen meanwhile, partly urged by his own fighting spirit, partly compelled by Russian counter-attacks, had been involved in constant fighting on and for the San line. The Austrian IV. Army was strained to the utmost in holding onto the positions it had gained on the middle San (below Skibawa) and in front of the link Nisko-Tarnobrzeg (or "San angle position") which joined Radko Dimitriev's front to that of Evert on the Opatowka. The right of the XI. Army was mainly held up by the Russian positions about the Radymno bridge-head, and Przemysl interposed a formidable obstacle between that army and the advancing Puhalla group (the left of the Austrian III. Army, which included also the German Beskidenkörps). But the left of the XI. Army stormed the Jaroslaw bridge-head and, crossing into the Lubaczowka valley, pressed the right rear at the Radymno bridge-head farther up the San. On May 24 a general assault carried this line, and the Russian centre, its right still holding the "San angle" position and the San below Sieniawa, fell back to the line of the Wisluta, the Grodeck lakes, and the Wereszyca. Practically at the same time, the right of the XI. Army, Puhalla, and the left of the II. Army closed upon Przemysl from the N., W., and S.; after severe fighting the fortress fell on June 3, as described under Pazzarski. Farther E., the right of Böhm-Ermolli's and the South Army, advancing in the last ten days of May, reached the line Weliko Bloto ("great marsh") on the Dniester-E. of Drohobycz-S. of Stryj-Dolina, making contact at Jasen with the left of the VII. Army, which was holding, still with success, the Pruth line.

The Russians, however, failing as were their resources, reacted powerfully. The Grand Duke's instructions were that "for political reasons, it is imperative to hold" the Opatowka-San-Grodek line "at all costs," and he carried them out by a series of heavy counter-strokes. First on the lower San against the Austrian IV. Army, then on the Pruth against Pflanzler-Baltin; and lastly against Linsingen on the Stryj front; offensives on a large scale were delivered in the latter half of May and the first week of June. New masses were drawn from an army at Odessa which was to have cooperated in the attack on Constantinople. Even Woytsch's advance, far away on the Kielce-Radom railway, was opposed by stubborn defence and sharp local counter-attacks. But in the last resort the Grand Duke's forces were inadequate for prolonged defence. The long exposed flank of the northern corridor compelled him to keep fairly large forces inactive on the Narew, the Bohn, and the Memel; and the Lauenstein operation in Courland (described below) made a continual drain on his northern resources. But above

all, the failure of munitions led to enormous losses, both in counter-attacks and in rearguard operations. By June 16 the Russians had lost, in the battles of Gorlice-Tarnow, the San, Stryj and the Pruth, no less than 392,000 in prisoners alone, besides 304 guns. The last acts of this phase were the forcing of the Grodek lines by Mackensen's two armies on June 16-19 (see LEMBERG, BATTLES ROUND, Section II.) and the successful two-fronted battles of Linsingen's South Army about Stryj and Drohobycz, in which his left, facing north, held off the counter-attacks of the Russian XI. Army, while his right, by intervening in the flank of Pflanzer-Baltin's opponents (IX. Army, Letchitsky), made them retreat to the Dniester (May 31-June 15).

*The Bug and the Narew Campaigns.*—Although the Russian retirement in E. Galicia was not, as Conrad imagined for a moment after the fall of Lemberg on June 22, a retreat in dissolution, it was definitely a retreat on the largest scale. Once the gap between the San and Dniester had been forced, neither was tenable by the defence. Very soon, therefore, the Russians on the Dniester were taking down their line from right to left, to re-form on the positions offered by one or another of the N.-S. tributaries of that river. From the San, the Tanev and the region of Rawa Ruska, the retreat took a northerly direction and thus there came up again the same possibilities, risks and alternatives for the Austrian offensive as those of Aug. and early Sept. 1914. The conditions were, however, partly changed. The Russians and Austrians alike had lost most of their peace-trained leaders and their offensive energy. Instead of the general clash of an encounter battle, it was now a case of retreat and of a follow-up, upon which delay was imposed by the necessity of restoring demolished communications, and caution by the risk of counter-attack striking the pursuit at a weak spot as it opened out fan-wise towards Lublin-Chełm and towards Sokal. Such a counter-attack did in fact bring the German XI. Army into momentary peril between July 7 and July 12.

The prospect of a slow advance of indefinite depth made it imperative for Falkenhayn and Conrad, and especially for the former, to reconsider the position. Hitherto the German leader had proceeded from one limited objective to another, all along the same general direction. Now—at the beginning of July—the choice had to be made between initiating a far larger operation and calling a halt to consolidate gains.

There were in reality two decisions to be made, one of principle and one of method. On the principle of continuing the offensive against Russia, Falkenhayn's opinion was, fundamentally, unchanged, and he foresaw new dangers in France owing to the impending appearance there of 12 British new army divisions, considered as heralding an attack. But deciding, on the evidence, that the great French offensive would not take place till Sept., and relieved of fears for the Italian front—impressed also, without doubt, by the repeated counter-strokes of the Russians—he decided on June 28 to initiate a new eastern offensive effort.

The second decision, as to the form and direction of this effort, was more difficult and controversial. Apart from Conrad's proposal, made once again, to strike from two directions against Siedlce, there were two schemes under consideration. One was from Ludendorff on behalf of Hindenburg; the other from von Seeckt, representing Mackensen. In the sequel, Falkenhayn accepted the latter, with additions of his own.

In Section I. of this article, mention was made of the geographical barriers, both flank and transverse, of the "northern corridor," and it was noted that the tendency of the latter was to turn southward in their upper courses, so that a series of gateways existed along the inner flank of the corridor. Seeckt's proposal, first made as early as June 15, was to wheel the two Mackensen armies sharply northward, pivoting at about the mouth of the San, to the line Ivangorod-Włodawa, with, as flank-guard against dangers from the Luck direction, the Austrian II. Army, which should advance, in échelon from the left, toward Vladimir Volhynskiy, E. of the Bug. Only the South Army and the VII. Army would remain to drive the Russians remaining S of Brody out of E. Galicia. The Austrian I. Army on the other side of the Vistula was to conform by pushing the enemy back

to about Josefow, and, itself crossing there, to come into line to the S.E. of Ivangorod, thereby allowing Mackensen (I., IV., and XI. Armies and Beskidenkopis) to condense on his right wing and drive forward on the Bug, with on his right, beyond the river, a deep échelon which could pull out and outflank the enemy's left wherever it was found. To this scheme it was open to Falkenhayn to add a similar enveloping element on the northern flank.

But, in accepting the plan, Falkenhayn and Conrad modified it considerably. The situation in E. Galicia did not seem to them to justify the plunge of the II. Army northward on Vladimir Volhynskiy. They therefore reserved this army, as heretofore, for operations in the Brody direction, and instead withdrew the I. Army from the central salient—Woysch extending, in place of it, to the Vistula—and reconstituted it about Rawa Ruska with orders to line the Bug as a flank guard in proportion as Mackensen progressed. It was during this regrouping that the Russian counter-attack of July 7, above mentioned, was delivered. A serious objection to Seeckt's scheme was, in Falkenhayn's eyes and probably in Conrad's also, the fact that the II. Army would have become involved in the marshes of the Pripet region N. of Vladimir Volhynskiy. Both Seeckt and, incidentally, Ludendorff considered the difficulty of this country to be exaggerated, and Falkenhayn admitted after the event that this was so. In any case much would have depended upon the scale of the operations E. of the Bug, and this was just the unknown factor in the problem.

Falkenhayn therefore limited the Mackensen operation to the area between the Vistula and the Bug, thus turning some, but not all, of the transverse barriers by their inner gates. Reckoning upon obstinacy in the command and slowness of the machinery of his opponent, he considered that it would suffice to come in upon the rear of the Russian centre during its presumed evacuation of the central salient, at some point between Siedlce and Brest-Litovsk. But he was aware that the centre of gravity of the whole Russian line now lay opposite Mackensen, who would be called upon to make a purely frontal advance through country that was destitute of railways and would certainly be devastated. He therefore intended to deliver an additional blow from the other wing generally in the same direction; that is, to reinforce Gallwitz to such strength as would enable him to force, in succession, the Russian XII. Army's Przasnysz lines and the Narew barrier, and so to descend upon the same region from the other side, N. of the middle Bug. Thus he expected to obtain the maximum result that was possible, and within a time-limit set by the forthcoming French offensive in Champagne and by the Bulgarian peasants' harvest.

Ludendorff, on the other hand, aimed at the "annihilation" of the Russian armies and thereby the certainty of winning the war. He argued that Mackensen's movement on the left of the Bug would be a slow frontal drive; that a Gallwitz offensive toward the Narew would be brought to a standstill, or at the least reduced to the condition of Mackensen's, very little beyond the Narew; that Byelostok could not be reached with certainty by an offensive from the VIII. Army front (Osowiec), such as had been projected in the Masurian campaign, though he and Falkenhayn were agreed as to this being, ideally, the decisive point; that Kovno and Grodno effectively held the middle Niemen line; and that, in effect, the only practicable envelopment was one which, starting from the N. of Kovno, swept round and invested that fortress and swung in by Vilna toward Molodechno and Minsk. The cross-barrier of the Vilya, and that alone, was sufficiently far back from the present Russian front to ensure the cutting-off of the entire Russian army in Poland, Polesie, and southern Lithuania. To complete the "Cannae," he proposed that the Mackensen group of armies should place its centre of gravity on, and even E. of, the Bug, as laid down in Seeckt's original plan.

To understand the significance of this proposal and the arguments for and against it, it is necessary to realize the new position of affairs on the extreme left of Hindenburg's front. At the close of the Masurian winter operations the K. Army

leaned to the left on the lower Niemen, rather east of Tilsit. In March there had been some advances and retreats on both sides but no substantial change in the situation. A raid on Memel, beyond the left flank of Eichhorn's Army, by a small body of Russian militia from Libau (who were expelled after doing some damage) was the only incident of importance. N. of the Niemen till, in mid-April, Hindenburg received orders to deliver feint attacks in order to divert attention from the forthcoming Gorlice offensive. He chose, for this purpose, the region N.E. of Tilsit, and formed a mobile army group of infantry and cavalry divisions under General von Lauenstein. In this quarter the Russians had only small forces, and the advance could be carried out in three separate columns, thus covering an enormous front. In all, 3 infantry and 3 cavalry divisions were sent out on April 27, by Memel toward the Vindava, by Tauroggen on Shavli (Schaulen, Szawle), and by Yurborg on Sredniki and the Dubissa line. A small raiding body, in conjunction with light naval forces, took possession of Libau early in May.

Lauenstein's movement was unexpected, and his left column penetrated to Mitau before the reaction set in. The others made good Shavli and the line of the Dubissa, and during May and June a series of fierce battles on a small scale took place all along this line. The Russians brought up considerable reinforcements under the V. Army staff, and the first object of Lauenstein's enterprise thus attained marked success. But, like other wide extensions of front in the war, as soon as serious infantry fighting opened, manoeuvre began to call upon reserve resources for its maintenance. Two infantry and 2 cavalry divisions were added to the German force, which became the "Army of the Niemen" under Otto von Below, Scholtz succeeding this officer as the head of the VIII. Army. Thus, at the end of June, when the plan of future operations was being settled, the ground was prepared for the manoeuvre advocated by Ludendorff. From Shavli, with flank guards set out successively towards Riga and Dvinsk, the Niemen army could, after being made sufficiently strong to defeat the Russian V. Army assembled in front of it, turn Kovno and reach the Vilya line long before the Russians in retreat from western Poland could do so. On the other hand, so grave a peril would clearly bring into existence a new Russian army of relief in the Riga-Dvinsk-Petrograd region, and this army would make short work of a few flank-guard divisions facing Riga, Jakobstad and Dvinsk. One necessary condition of Ludendorff's plan, therefore, was heavy reinforcement of the Niemen army; another the reduction of Kovno, so as to clear a direct and safe line of communications Insterburg-Vilna and to bring the X. Army into action E. of the Niemen. From Falkenhayn's point of view, however, the eccentricity of the whole manoeuvre was its gravest drawback. He doubted whether so distant an operation would affect the situation of Mackensen, but especially whether it would not become just that plunge into the unlimited interior of Russia which, with his time-limit fixed, he dreaded above all. Operations N. and E. of Kovno were permissible, in his opinion, only for hunting down an army already in dissolution, not as a preliminary to the battle that was to bring about that dissolution.

Such, in sum, were the elements of a controversy between Falkenhayn and Ludendorff, which in the course of the summer created a serious breach between the Supreme Command and the commander-in-chief East, and undoubtedly handicapped the operations, for Falkenhayn never swerved from his intention to close down the campaign as soon as an "adequate" result had been achieved, and Ludendorff on his side returned to the charge at every opportunity, with the result that the few available reserves were handled without singleness of purpose.

The Ludendorff plan, first proposed as early as June 7, was discussed fully at a conference on July 2, in the presence of the Emperor William, who, bound by the practice of the German army either to follow the counsels of his sole and responsible adviser or to dismiss him, chose the former course.

It was decided therefore that Mackensen, after completing his wheel-up, should advance with all possible energy against his immediate opponents between the Vistula and the Bug,

with the reconstituted Austrian I. Army protecting his right flank by making good the line of the upper Bug as he advanced; and that Gallwitz's army group, reinforced, should break through at Przasnysz and on the Narew. When Gallwitz's operation, with its immediate relief to Mackensen, should have been completed, then Falkenhayn was prepared to allow an extension of the offensive to the middle Niemen region.

On Mackensen's front the wheel-up was completed in the midst of a heavy Russian counter-attack, and the advance that was to follow was involved in great difficulties from the outset. His three armies—from left to right, the Austrian IV. and the German XI. and Bug Armies (the last newly formed under Linsingen)—had not moved appreciably when Gallwitz's attack was delivered. The Russians had massed considerable forces to deny access to the inner gates of the corridor, and under cover of their activity had already begun the evacuation of the central salient. There all the old line had been already given up. S. of Inowlozd on the Pilica, and, on Mackensen's intention becoming evident, the retreat was continued to the line of the Vistula itself, where, however, the foreground of Ivangorod and, especially, the great entrenched positions west of Warsaw continued to be held in force. The German IX. and Woysrch Armies in front of this line, now constituted as a group of armies under Prince Leopold (probably in order to give Falkenhayn a force independent of both Hindenburg and Conrad), had been weakened and could do little more than follow up, boldly on the right but very cautiously on the left where the Warsaw positions and Novogeorgievsk imposed respect.

When Woysrch reached the region of Ivangorod (July 11) a little progress had been made on the Mackensen front but Conrad proposed that Woysrch should cross the Vistula above that fortress, so as to intervene in rear of Joseph Ferdinand's opponents. This movement, which would have thrown the axis of Woysrch, and eventually that of the IX. Army also, away from the region of the middle Bug and put an end to all hopes of cutting off the Warsaw group of the enemy, was opposed by Falkenhayn and also by Mackensen, and Woysrch received orders to cross the Vistula below Ivangorod, as he did on the night of July 28-29 near Muciejowice. The IX. Army meanwhile felt its way forward to the Warsaw lines and the S. front of Novogeorgievsk.

Before any of these movements were under way—largely indeed with the intention of helping them to get under way—the Gallwitz group, reinforced from the central salient by 4 divisions to a strength of about 15, had opened its offensive on July 13-16, by breaking through the Russian XII. Army's trench-lines at and west of Przasnysz (see NAREW, BATTLES OF TWE). On the night of the 17th Gallwitz stood within range of Ostrolenka on the left and the N. defences of Novogeorgievsk on the right. But a new and more severe effort was needed for the forcing of the Narew line itself. Russian counter-attack forces arrived in time, and it was only on Aug. 8—more than 3 weeks after the offensive began—that the Gallwitz group, now styled XII. Army, had made good a line E. of the river defined by Serock-Wyszkow (on the Bug)-E. of Ostrow-R. Ruz, the last named being occupied by the right of Scholtz's VIII. Army which had advanced in sympathy. The right of the German XII. Army meantime, W. of the Narew and facing S., was holding its own, not without considerable difficulty, against repeated counter-attacks issuing from the Novogeorgievsk defences, where the Grand Duke maintained large mobile forces up to the eleventh hour—and indeed beyond it.

In these 3 weeks Mackensen's right, the Bug Army, had been engaged (see BREST-LITOVSK, BATTLES OF) by the Russian XIII. Army, at the halt on almost every line of E.-W. streams available. It had fought on the line Grabowiec-Grubieszow from July 10-21, on that of Chelm-Annapol from the 21st to the 31st, and along the Ucherka river and at Sawin in the first days of August. The XI. Army, with better conditions, had advanced first astride and then east of the Huczwa, and by Aug. 6 had reached Lubartow-Sawin; while Joseph Ferdinand had—without the suggested flanking assistance from Woysrch—reached the

H

I

J

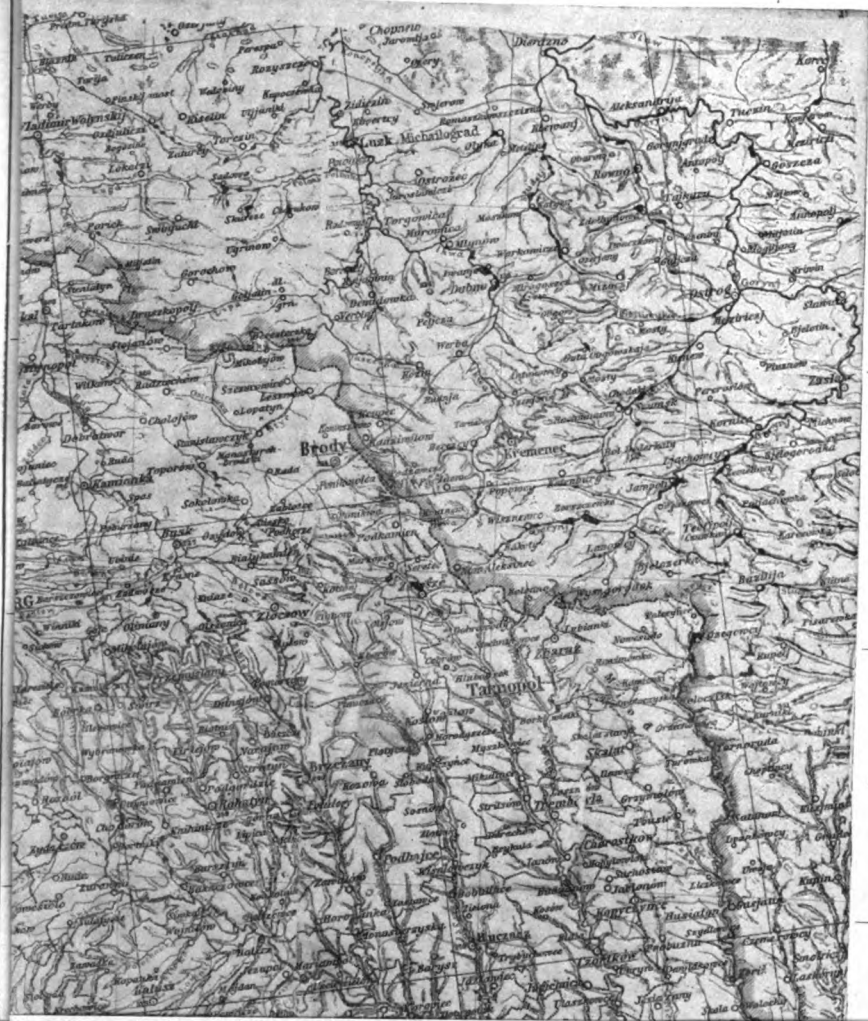



the Novo Alexandryn-Lubartow. In the centre Wayrach had extended his Muciejowice bridgehead and was passing all his forces over the Vistula for the advance on Siedlce-Lankow, and under this threat the Russians had entirely evacuated the left of the Vistula. Warsaw city fell on the 5th, though the German IX. Army was unable to force the river—there a kilometre broad—till the 8th. Ivangorod was evacuated on the 5th. Thus the German front had assumed a still more pronounced N.E. direction than at the beginning of the Mackensen manoeuvre; owing to its battle and route conditions, Linsingen's Army was back instead of forward of the alignment, and the Russians had retreated clear of the dangerous central salient to a line marked by the Liwiec, the Bystnica and, facing Mackensen, the middle Wieprz, the Swiaka and the Ucherka. The Austrian I. Army, occupied principally with flank-guarding Linsingen along the Bug, had advanced its right to Vladimir Volhynskiy but no farther. On the other flank of the Russian retreat Gallwitz was firmly held for the time being. In other words the Russians—handled with great skill by General Alexeiev, commander-in-chief of the N.W. front, were successfully effecting their retreat to that line (Kovno-Grodno-Brest-Litovsk-W. of Kovel-Luck-Dubne) which had been already in peace-time regarded as the line of safety for deployment. In territory, they had abandoned no more than they would have been prepared to give up gratuitously in their pre-war concentration scheme.

But this in itself was, after a year of warfare, a confession of defeat. The enormous losses of that year in men and material—losses such that the great army of peace-time with all its resources had practically ceased to exist and the stocks of arms no longer sufficed to equip even the men in action, led alone new formations, with rifles—left no doubt that as a dominant factor in the war Russia was out of the reckoning. In the light of after events, the decision to continue the struggle after the loss of the San line in June is seen to be the first step to the Russian Revolution. Yet, on purely military grounds, it was justifiable on the assumption that the French effort to break through the Champagne front would succeed. Only this confidence in victory in September, indeed, can explain the stagnation on the Western front from April to August (broken only by the May battle in Artois), enabling Falkenhayn to withdraw some 5 divisions for the Eastern operations.

By August it was evident that the chances of cutting off any considerable formed army of the Russians in the Kielce region was at an end, and again there came up on the German side the controversy between Falkenhayn and Ludendorff as to what the operations were intended to achieve; Falkenhayn held firmly to the view that the Russian army must be beaten before any wide enveloping movement was undertaken to surround its debris. Writing after the war, he maintained the same opinion, only reproaching himself with not having compelled G.H.Q. East to give Gallwitz 20 divisions instead of 12. And certainly, if prisoners and booty were considered, he had in fact inflicted what by all military standards was a "sufficient" or "decisive" blow—for by the middle of Aug. the Russian losses in prisoners alone had reached the figure of 750,000 since May 1, nearly 50% of their combatant strength as it had been at the end of April. But the time-limit was close at hand, and the withdrawal of forces to France and Serbia, delayed as long as possible, had now to be begun. The weeks remaining must, according to Falkenhayn, be devoted to inflicting as much additional loss on the Russians as was possible by frontal pressure coupled with flank attacks on the middle Niemen and east of the Bug, i.e. in the immediate vicinity of the frontal fighting, and possibly raids by light forces on the communications behind Kovno and Brest-Litovsk. At a suitable date the operation would be closed down, and the best line of defence taken up as a winter front.

Ludendorff, on the contrary, considered that the actual annihilation of the Russian armies was the only "sufficiently decisive result" that would give freedom of action in the West, and with renewed insistence—which went as far as a personal appeal by the Field-Marshal to the Kaiser—demanded the

reinforcement of his left (Niemen army) with a view to quick swooping down on Vilna and Molodechno and the closing of the "corridor." The axis Orany-Lida, originally suggested, was now too near for the required effect, but the principle was the same, and the movement would originate from a more favourable situation of the Niemen army than that existing in June. Preparations for the attack on Kovno by the X. Army were already well advanced, and Ludendorff considered that even at this stage complete success would be possible.

At this period the fighting on the Vindava-Schavil-Dubissa line had definitely turned in favour of the German Niemen army, the Russian V. Army receiving little or no further reinforcements when Mackensen's and Gallwitz's attacks developed. Below was progressing beyond the line named in each of the three directions Mitau-Riga, Poneviesh-Dvinsk, Keidamy-Wilkomir, and about Aug. 1 his various columns, totalling about 7½ inf. and 5½ cavalry divisions, were approximately on the line River Aa-R. Musba-E. of Poneviesh-Keidamy. To the southwest, the German X. and Russian X. Armies were still making war in the same fashion as in March, the Germans based on the Suwalki-Schali lines, and the Russians on their Kovno-Niemen-Grodno fortifications, making periodical thrusts in the region between. But the last important Russian thrust was delivered early in May, as a "relief offensive" toward Schali; and the German reaction became a methodical advance toward Kovno and Olita, which at the time here considered brought their left almost up to their opponent's stronghold. Behind the German advanced line preparations had been made for the siege of Kovno, an essential part of the scheme which Ludendorff still advocated.

*The Final Phase.*—It was evident that the scheme of bringing Below and Eichhorn down upon Vilna and Molodechno, and capturing Kovno in time, would call for the reinforcement of either or both, and, on this ground principally, Falkenhayn preferred to continue the campaign on the same lines as before, though a little later he conceded to Hindenburg freedom to dispose as he chose of the forces in his own area and to Mackensen freedom to pass to the E. of the Bug. Conrad, meantime, was planning an operation in East Galicia with the II., South and VII. Armies.

Thus the last phase of the tremendous campaign consists of 4 parts: (a) the frontal drive of (right to left) the Bug Army, the XI., Woysch, IX., XII. and VIII., (b) the attack on the north flank and the rear of the "Corridor" by the German X. and Niemen Armies, (c) the N.E. swerve of the Bug Army and the A.-H. I. Army, and (d) the autumn campaign in E. Galicia. All these were carried out without any great regrouping or reinforcement, and indeed, as regards (a) the forces concerned, were gradually reduced in order to form the army for the Serbian front and to increase the reserve in France. In the case of the operations in E. Galicia, the Russians followed a clear purpose and the parts of their efforts were coordinated. But elsewhere, under the tremendous pressure of the row of hostile armies stretching from Lomza to Wlodawa and Vladimir Volhynskiy, the only general policy was that of gaining time at the expense of ground and of avoiding envelopment at all costs, and the day-to-day situations were met as best they could be. On the German and Austrian side the offensive energy of the troops was beginning to approach its limit, except as regards troops N. of Grodno, so that it may be said that the allied left and the Russian left alone retained the capacity for fresh achievement, while the rest were wearing each other out at an increasing rate.

The central campaign, between the Bobr and the Bug, may best be summarized by recording the battlefields of each of the German armies in succession.

Protected on its right by the Austrian I. Army, the Bug Army fought and won the battles of the Ucherka (Aug. 7-12) and of Wlodawa (Aug. 13-17), and in concert with the XI. Army continued its advance northward along the Bug against Brest-Litovsk. Meantime, the crossing of the Bug was authorized in so far as concerned the establishment of bridgeheads; and in carrying out orders with this object the German subordinate



leaders became involved in fighting E. of Wlodawa, which inevitably formed the starting-point of an offensive against the eastern communications of Brest-Litovsk. By Aug. 21, then, the greater part of the Bug Army was engaged on the line of the Kapajowska from its mouth to Switiaz lake inclusive, well inside the region of the great marshes; the remainder (Beskidenkorps only), still west of the Bug, was nearing the outworks of Brest.

To the left of the Bug Army, the XI., already being reduced for the forthcoming Serbian campaign (for the conduct of which its staff was presently withdrawn), moved forward correspondingly against the W. of Brest. On Aug. 19 its left had reached Janow on the Bug below the fortress, while the Beskidenkorps stood at Koden on the same river above it. To the left of the XI. Army, again, the Austrian IV. Army at that date lined the Bug between Janow and Niemirow; and beyond Joseph Ferdinand, already N. of the river, was Prince Leopold with Woysrsch's and his own armies, which, as soon as they had debouched from Ivangorod and Warsaw, had made rapid progress, as the Russian centre retreated at the fastest possible pace to escape while Gallwitz and Mackensen were still being held off. The German IX. and Woysrsch Armies stood, on Aug. 19, N. of Niemirow, facing the line of the Pulwa and the Nurzec on which the Russians were preparing to make a stand.

Meantime Gallwitz, in his bridgehead position in the angle of the Bug and Narew, had overcome the Russian counter-attacks, but not before their purpose of keeping open the railways and roads for the retreat of the Warsaw and Ivangorod forces had been achieved. The battles of Ostrow (Aug. 8-10) and Tschishev-Sambrow (Aug. 11-12) and the advance in the direction of Bielsk which ensued were thus similar in character to the operations of the IX. and Woysrsch's Armies, viz.: a direct pursuit where an envelopment had been hoped for. At the date of Aug. 18-19, Gallwitz stood between the Nurzec and the upper Narew, facing Biala, where the Russians were prepared.

The rightmost troops of the XII. Army, viz. those which in the battle of the Narew were facing south against counter-attacks from Novogeorgievsk and the strong points of the lower Bug, had now been combined with the leftmost troops of the IX. Army for the siege of Novogeorgievsk, in an army group under von Beseler, the captor of Antwerp; and this siege, pressed with energy, was nearing its close. On the 20th the place, with a large garrison, surrendered. On Gallwitz's other flank, the right of the VIII. Army had conformed to his advance and was taking the direction of Byelostok; its centre had mastered Lomza and Wiszna on Aug. 10; and its left was again, as in Feb., battering Oswiec, which fell to the superheavy artillery on the 22nd. Kovno, as will be seen, had already fallen on the 18th, to the attack of the German X. Army.

Throughout these pursuit operations large numbers of prisoners continued to be taken by the Germans, and the Russian fortress artillery swelled enormously the total of captured guns. At Novogeorgievsk some 85,000 men and 700 guns were taken. Shortly it was to be the turn of Brest-Litovsk and Grodno, though these places were not defended after the withdrawal of the battle-lines outside them.

The later stages of the frontal pursuit may be very briefly dealt with. The general direction of the Woysrsch, IX. and XII. Armies was eastward. From Aug. 19-24 Woysrsch and the IX. Army were engaged in mastering the Pulwa-Nurzec line, on which the Russians delayed their opponents long enough to cover the evacuation of Brest-Litovsk against interference from the N.W. or N. From the 25th to the 31st these two armies were involved in a fresh series of combats in and about the "primeval forest" of Byelewitsa. Meantime the XI. and (till its withdrawal) the Austrian IV. Armies, with the Beskidenkorps of the Bug Army, had attacked Brest-Litovsk concentrically from the W. and S., and the last Russian rearguards had been driven out of the evacuated stronghold on the 26th. The Germans and Austrians then continued the pursuit eastward, where the operations of the Bug Army and the Austrian I. Army (presently to be described) came into line with theirs in the early part of Sept. The XII. Army drove the Russians from the Bielsk pos-

tions on the 26th, from the Swielocz river a few days later, and from the Naumka-Wereczya line on Sept. 4, at which date the IX. Army and Woysrsch had at last debouched from the Byelewitsa forest towards the Jasiolda river.

In general, the effort of the Bug, XI., IV., Woysrsch and IX. Armies in the earlier stages of pursuit had tended to crowd the Russians into the area round Brest-Litovsk, and at a certain stage in this process the Bug Army had been authorized to push through the marshes E. of the river so as to reach the line of communications Brest-Litovsk-Kobrin-Pinsk. At the same time the Austrian I. Army about Vladimir Volhynskiy advanced to Kovel, and thence eastward (see *Austrian Campaigns in East Galicia* p. 907) while from Kovel its cavalry worked up through the marshes northward to join the swinging right wing of the Bug Army. But that army, although it drove the retiring and diminishing forces of its opponent N.E. from the Kapajowska to Kobrin, was unable to reach that point before the Russians evacuating Brest-Litovsk had flowed past it. The Russian rearguard stood to fight on a line N.W.-S.E. through Kobrin, but the Austro-German Cavalry Corps of General von Heydebreck from Kovel arriving on their flank, they soon fell back to the oblique line of the Dnieper-Bug canal, where they were temporarily secure against all but frontal pressure. Thus in this quarter too the pursuit became a direct one. The Russians were driven by the Bug Army and by what remained of the Austrian XI. and Austro-Hungarian IV. Armies—the whole now commanded by Linsingen—out of the canal lines in the battle of Horodec (Aug. 31-Sept. 1) and out of the defences of Dwohiczyn-Chomsk (Sept. 4-6). But Linsingen's offensive, more and more hampered by poor communications, came to an end with the occupation of Pinsk on Sept. 16, and positions were taken up here which remained unchanged till the end of the war.

With the almost simultaneous capture of Brest-Litovsk, Bielsk, and Grodno (the last named fell to the German VIII. Army on Sept. 2-3), the Germans obtained possession of that line across the northern corridor which had usually been regarded as the Russian stabilization line. Falkenhayn, however, took full advantage of the shortening of front which resulted from the directions taken by his armies, and then at last Ludendorff's scheme came into play.

Such an operation as Ludendorff contemplated, or at least one from the middle Niemen, Falkenhayn had been willing to agree to from the first; and as the occasion approached he relaxed his hold on Hindenberg's dispositions, stipulating only for the observance of his general directions and for the select of certain divisions for the West. In practice he approved the attack on Kovno. Ludendorff promptly took advantage of this, and the intended wheel-in upon the rear of the "corridor" was already in progress before the fall of Grodno and Brest-Litovsk. On Aug. 8 the X. Army was able to begin the siege of Kovno. Ten days later the fortress was in its hands—even earlier than at Novogeorgievsk, Oswiec, and Brest-Litovsk. On condition of strengthening either the Niemen army or the left of the X., therefore, Ludendorff's plan had become feasible, if feasible at all, while masses of the enemy were still south of Brest-Litovsk, on the Pulwa and the Nurzec, about Bielsk and Byelostok and Grodno. At that date, Aug. 18, the Niemen army had pushed its left columns close up to the Riga-Uzhiti bridgehead on the Dvina, and to Friedrichestadt on that river, whence its centre and right ran southward along the Jara and Sventa to the north side of Kovno. It was still very strong in cavalry, but some of its transport had been taken for the armies pushing through the devastated areas to the South.

Nevertheless, no serious advance was made to the westward from Kovno for more than a week, and even then part of the X. Army swerved full to the south against Olita to open an advance in the direction of Orany, and also to help the VIII. Army in cutting off Góbdno, now a pronounced salient. At this late stage Ludendorff himself had doubts of the efficacy of the westward movement, and for a moment contemplated taking the direction favoured by Falkenhayn, viz.: Orany, Izhin, Baranovich. Not only was this the shortest route to the enemy's

heart—the shortest, that is, as measured by the time necessary for concentrations and for rebuilding routes—but it offered hopes of driving a large mass of the enemy into the marsh region round Slonim, where the avenue of escape was narrowest (whereas at the latitude of Vilna-Molodechno the corridor broadens out considerably). However, he chose, in the end, to follow the current scheme of operations, as offering "annihilation" of the enemy as a prize, though admittedly that prize might escape him. On the 28th, therefore, with the expressed or implied consent of Falkenhayn, the X. Army was ordered forward on Vilna, with centre of gravity on the north wing, north of the Vilya. Reinforcements were collected from the troops lately besieging Novogeorgievsk and from the VIII. Army, which, after the fall of Grodno, would evidently be grounded out of the line. The Niemen army was directed to press up to the Dvina bridgeheads and, especially, up to Dvinsk, to cooperate with its left wing in the operations of the X. Army north of the Vilya, and to prepare a mass of cavalry to break through the thin line of the Russians near Swentsiany and seize or destroy the railways at Molodechno and Minsk.

The last great battle of the campaign, known as that of Vilna-Molodechno, began after the Grodno episode had been closed on Sept. 9. At that date Linsingen was advancing on Pinsk, Woyrsch and Prince Leopold driving the enemy slowly from one river-line to the next, over the Jasiolda, in the direction of Slonim; and Gallwitz and the remnant of the VIII. Army were pressing slowly forward up the Niemen in the same direction. The Niemen army was, by its activity between Riga and Dvinsk, forestalling and perhaps diverting the attack of new Russian forces which were coming up from the Baltic provinces. From Wilkomir, north of the Vilya, to Orany, the X. Army engaged the very heavy forces that the Russians had collected for the last effort to hold the flank of their corridor—the flank act of command of the Grand Duke Nicholas before the Tsar took over the control from his able hands. The German offensive progressed slowly, like all offensives against the Russian flanks in this campaign, but after some days it was judged that the forces on the Dvina and amongst the Dyvnek lakes had obtained sufficient security for the left flank, and on Sept. 11 the German cavalry divisions broke through the cordon west of Novo Swentsiany and made for Swentsiany and Molodechno. On Sept. 14 the horsemen reached and broke the Vilna-Molodechno line at Smorgon. At Wilejka and farther north at Glubokoye they cut the vital Lida-Plotk line. A party even reached the Minsk-Orsha line at Smolewice.

This last crisis was also the most dramatic. The first wave of cavalry was followed by others till about seven divisions were collected about Wilejka, Smorgon and Molodechno. But, recovering from their first surprise, the Russians quickly sent troops from Vilna and from Minsk, as well as from the south-east of Dvinsk, to clear their intercepted lines of retreat. These had to be recovered at all costs, for, while the forces retiring before Gallwitz, Leopold and Woyrsch still had the lines focussed on Baranowichi at their disposal, these could not help the northern masses, and it was in the north, towards Vilna, that the centre of gravity lay.

Thus a race to build up forces about Smorgon, Molodechno and Wilejka set in. The Russians, having the better communications and consequently the larger forces, won it. They drove back the German cavalry, after a continuous skirmish of five days, to the west of Smorgon and the north-west of Wilejka. Two days later the first infantry divisions arrived on the German side from the left of the X. Army. The détour of these troops along the north bank of the bending Vilya had enabled the Russians, moving on the shorter line, to reopen their line of communications; and, with this, the battle of Vilna became, as the battles farther south, a slow frontal drive. Thereupon Falkenhayn ordered operations to be broken off and movements to be withdrawn on other theatres, and fixed in general the line to be taken up as a winter line. The concluding operations of the campaign, mostly completed in early October, consisted in the methodical advance of all armies to this line,

which, so far as the Hindenburg, Leopold, and Linsingen groups were concerned, ran from Tuckum, on the gulf of Riga, past the south side of Riga and parallel to the Dvina to Novo Alexandrovsk, and thence southward by Lake Drisvyzty and Lake Naroch, Smorgon, Krewo and Baranowichi to Pinsk, south of which point Linsingen's right came into touch with the left of the Austrian operations in East Galicia.

*Autumn Campaign in East Galicia.*—In East Galicia the pursuit of the Russian VIII. and IX. Armies, after the Grodek-Lemberg break-through in June, had been left by Conrad and Falkenhayn to the Austrian II. Army, the German-Austrian South Army, and to Pflanzer-Baltin. Although the first impressions of the victors in that battle had been that the Russian armies remaining in East Galicia were incapable of more than retreat and rearguard fighting for a long time to come, in fact it cost the Austrians and Germans much fighting and manoeuvring to establish themselves on the line of the upper Bug and the Zlota Lipa; and Pflanzer-Baltin was at one time subjected to a heavy counter-attack by General Lechiteky's Army, for in this quarter the Russians had an ample supply of reinforcements in their Odessa Army. Towards the end of July, however, the fighting in Galicia died down.

Towards the end of August, as a part of the same final offensive act which produced the battle of Vilna-Molodechno in the other flank, Conrad initiated a campaign which was intended to confirm the separation of the northern and southern groups of the enemy and to clear the latter out of Austro-Rumanian territory definitively. The thinness of the defensive cordon in the Pripet marshes, revealed by the lack of serious opposition to the movements of Puhalo's I. Army and beyond Vladimir Volhynskiy, and the advance of Heydebrek's Cavalry Corps across the swamps and forests to Linsingen's Drohiczyn battlefield, led the Austrian command to make its effort on the north side of the Lemberg-Brody watershed. Profiting by the general shortness of the line between the Bug and Vistula, Conrad withdrew the Archduke Joseph Ferdinand and the IV. Army from the Brest-Litovsk field of operations in the last few days of August, concurrently with the withdrawal, mentioned p. 906, of the German XI. Army for Serbia. During the gradual withdrawal of the IV. Army, Puhalo began his offensive from the line Vladimir-Volhynskiy-Kovel in a south-easterly direction.

The fighting which followed is described in the article ROVNO, BATTLE OF. The incoming of the Austrian IV. Army on Puhalo's left, on the one side, and the arrival of reinforcements for Ivanov's VIII., XI. and IX. Armies, on the other, led to the battle, spreading along the whole front from the Pripet to the Pruth. In sum, the Austrians, after advancing from Kovel to the rivers Goryn and Putilowka N.W. of Rovno, and from the Zlota Lipa to the Galician Sereth, were checked and driven back by a counter-attack group formed by Brusilov's VIII. Army in the region of Rajalowka. The rest of the Russian front taking up the movement, the Austrians were driven back from the Sereth to the Strypa; and from the Horyn-Stubiel line to the upper Strypa and Stokhod, while the centre held practically all its gains: From the fourth week of September the battle, after some further fluctuations on the left, became a stabilized trench-warfare conflict which dragged on till mid-November, when both sides settled down in their winter lines. These ran from the Pripet along the Strypa and the Korwin and thence past Dubno to Zborow and so along the Strypa. From the Strypa mouth to the Sereth mouth, the Austrians retained positions north of the Dniester, and from that point Pflanzer-Baltin's front substantially followed the frontier to Rumanian territory E. of Czernowitz. Thenceforward up to the opening of the great Russian offensive in 1916 the only important operations which took place in East Galicia were the relief offensive known as the "New Year battle" (see STRYPA-CZERNOWITZ) initiated by the Russians in the hope, which was not realized, of calling off Austrian troops from Montenegro, and the Russian capture of the Dniester bridgehead of Uzciesko on March 19—a diverting attack in aid of the spring offensive of the north of the

(C. F. A.)

## IV. RUSSIAN FRONT, 1916-17

*Operations in Russia and East Galicia, 1916 and 1917.*—About the end of 1915 and the beginning of 1916 the rival belligerents in the World War were confronted with the necessity of making vital decisions. For the Central Powers and their allies the past months had been rich in results. In the Balkan Peninsula Bulgaria's entry into the alliance, and the conquest of Serbia and Macedonia, had opened the way to Constantinople and Asia Minor. The Allied army in the East had tried in vain at Salonika to bring about a change in the state of affairs. The Entente troops had been withdrawn from Gallipoli. Even the bloody battle in East Galicia and on the Bessarabian frontier at the New Year had had no effect upon the general situation. Against Italy, and in the French theatre of war, the armies of the Central Powers had successfully maintained their position.

The chief of the Austro-Hungarian General Staff, Gen. Conrad von Hötzendorf, proposed to clear up the situation in the Balkans as far as possible. Rumania must be forced to give up her ambiguous attitude by an ultimatum, supported by the presence in South Hungary of a powerful force of troops. Montenegro and at least the north and centre of Albania must be occupied by the Central Powers. These measures having been taken, an offensive, prepared in the meantime, on Salonika would end the campaign in the Balkans. But the chief of the German General Staff, Gen. von Falkenhayn, had since late autumn, 1915, remained with his plans in the West in the French theatre of war. He pronounced against an offensive at Salonika on several grounds, and his view of the political, military and technical difficulties of such an undertaking could not be waived aside. The German Gen. von Seeckt also upheld Falkenhayn in this, on the strength of a conference with the Bulgarian Army Command. While the plan of an attack on Salonika was rejected in this manner, pressure on Rumania was now likewise deemed unnecessary, since the military successes of the Central Powers had meanwhile caused a more conciliatory attitude at Bucharest.

As regards the Austro-Hungarian Army Command's plans for dealing with Montenegro and Albania, Falkenhayn tried to postpone these indefinitely. But Conrad clung to his point and carried out his intentions, more or less against the will of his German colleagues, whereupon a most acute personal quarrel broke out between the two generals, lasting nearly a month.

This quarrel, in the course of which Gen. Conrad had the satisfaction of seeing his troops take the Lovchen (Lovćen) and subdue Montenegro, obviously laid no promising foundation for their common decisions in the future.

The idea of bringing about a decision in the war by a campaign against Kiev or Odessa in the spring of 1916 seems to have engaged political rather than military circles in Vienna and Berlin. In the latter the Russian operations in 1915 only strengthened the old conviction that the Russian armies—thanks to the illimitable area of operations and the skill of the Russian leaders in retreat—would always slip their heads out of the noose again, and that any further advance of the Central Powers towards the east could only result in an inconvenient extension of the front. The war, according to the view of both the General Staffs, could only be won against the western opponents. Conrad proposed a combined offensive against Italy. An annihilating blow delivered against this enemy would have been not only in accord with his personal feelings and those of his armies, but was worthy of consideration on many other important grounds. The tension on the Italian front was increased for the Austro-Hungarians by every new defensive battle; the Italian menace to Trieste became more intolerable week by week. On the other hand, Italy was easier to overthrow than France—or England, for that matter; and, as often before in history, the fate of the Rhine might be decided in the plain of the Po. Falkenhayn did not refute these arguments, but he was doubtful whether, in the first place, it would be possible to force Italy to break with the Entente, in view of her dependence on England, and, in the second, whether even if, contrary to expectations, Italy's overthrow should be brought about, the Western Powers would take the loss of this Ally so

very much to heart. Falkenhayn was convinced that the decisive campaign could be fought only in the French theatre of war. Conrad held to the other solution, but declared himself willing to place a few particularly good fighting corps at the disposal of the German Higher Command for use in France. This offer was declined by Falkenhayn both on military grounds and as a matter of prestige. He proposed as an alternative that his allies should take over, in addition to the 400 km. of front which they were defending between the Bessarabian Pruth and the Pripet (Prypeč) against the Russians, a further portion of the Lithuanian front stretching towards the north. In this way it would become possible to set free more German troops for the attack on Verdun. But Gen. Conrad could not bring himself to accept this purely passive rôle, and the result of the difference of opinion was that the two empires of central Europe divided their forces, the one proceeding to the attack in France, the other to the Venetian mountains.

*The Eastern Front in March 1916.*—For the execution of these attacks, forces that had been set free in the Balkans were brought up and others from the Russian theatre. The German eastern troops were, between Oct. 1915 and Feb. 1916, reduced from 56 to 45 or 47 inf. divs., not to mention the exchange of other fighting troops for less serviceable units. Heavy artillery and technical supplies were also withdrawn and sent to France, but these could be adequately replaced, thanks to the mechanical power of German industry.

The Austro-Hungarian eastern front in March 1916 was organized as to have 6 divs. less than at the close of the fruitless October campaign in 1915. To balance this, however, a series of regts. and batts. were brought up from other divs., so that the Austro-Hungarian eastern armies gave up, in all, 120 batts. for the attack on Italy. The drafts for the infantry in this fighting force were supplied mostly from home at regular intervals, the drafting reserve being overfilled owing to the slight loss entailed by the war of positions. Out of this superfluity of men the regts. formed 5th and 6th Batts. Thus there could be no question of numerical weakening on the Austro-Hungarian eastern front. Far more heavily weighed the fact that the best and most reliable troops had been picked for the Italian attack including nearly all the German-Austrians and a great proportion of the Magyars. The eastern armies were seriously weakened thereby on the moral side; and the militia-like character which the Austro-Hungarian army had begun to take on in the Carpathian battles in the spring of 1915, now became particularly apparent in the east. Still more severely felt was the withdrawal of the whole of the heaviest artillery, and a considerable portion of the medium-heavy, to the Italian theatre, and the considerably smaller share of technical supplies which had been assigned to the eastern front when these were divided.

In the beginning of March there were about 40 Austro-Hungarian and 46 German divs. on the Russian front. Of these, 47 German and 2 Austro-Hungarian held the front (Pinsk) between Riga and the Pripet and were under the German Higher Command, the other half of the fighting forces, in the south portion of the front, was under the orders of the Austro-Hungarian Army Higher Command (Teschen). Each section had a breadth of 400 km. The Austro-Hungarian divs. were on an average 4 batts. strong, the Germans only nine. The inferior rifle-shooting of the Germans was abundantly compensated by their superior equipment in artillery and fighting material of all sorts. The entire rifle-strength of the forces of the Central Powers on this front amounted at this time to rather more than a million. It would be safe to estimate the Russian front at double that strength. The Russian Higher Command, controlled since autumn 1915 nominally by the Tsar but actually by his chief-of-staff, Gen. Alexiev, could draw on its drafting reserve to the fullest extent. In the spring of 1916 the regiments, in spite of the gigantic losses suffered in the last campaign, had been replenished for some time. Immediately behind the army front were enormous masses of reserves, and all the recruiting depots were full: Half of the world's munition factories were straining to supply equipment for the Tsar's armies. A number of En-

tants officers were instructing Russians in the western methods of attack. Along with all this the greatest efforts were made to raise the soldiers' moral.

By March 1916 about 130 inf. divs. and 40 cav. divs. stood on the Russian front, the inf. divs. consisting of 16 batts.—almost double the number of the German. This did not include the draft formations standing in readiness immediately behind the fighting reserve. The rifle strength of the front might safely be estimated at 2½ millions. Her allies might well hope that Russia, in spite of her defeat in 1915, would come up to expectations in the general offensive planned for the summer.

*Battle of Lake Narocz (Naroch), March 18-29 1916.*—The German attack on Verdun in Feb. 1916 brought the Russians into action earlier than was expected. Like Italy, who was now making her fifth attack on the Isonzo, the empire of the Tsar was expected to lose no time in doing its utmost for the relief of France. Russia had already transferred her centre of gravity to the area N. of the Pripet before this demand reached the Higher Command. On this section, that is, opposite the German front, were 80 out of 130 Russian divisions. Since the beginning of March Hindenburg's general staff (Kovno) had located a concentration of Russian troops at Smorgon; Dvinsk (Dina-burg) and Jakobstadt. On the other hand, the attack of the II. Russian Army under Gen. Smirnov on both sides of the Narocz lake on March 18 took the Germans somewhat by surprise. After a preliminary bombardment, such as had not yet been seen on the eastern front, this army flung itself upon the German XXI. Army Corps commanded by Gen. von Hutler. It was assumed from orders of the supreme commander of the Russian west front (Gen. Ewerth), which were captured by the Germans, that the Russians meant more by this attack than a mere relief offensive. While Gen. Litvinov's I. and Gen. Plehve's V. Armies were holding the weak German forces occupying the trenches at Widsay, Dvinsk, and Jakobstadt, Smirnov was to force a way through in the direction of Vilna-Kovno and then to wheel northwards and so drive the German wing to the sea.

The "Narocz Offensive" led at first to considerable successes for the Russians. The attack delivered between the Narocz and Wiszenew lakes by Gen. Balujew with 4 army corps pressed the weak German forces backwards some miles between March 18 and 21. Though the groups attacking farther to the N. were not so fortunate, the Russians might yet hope for success. Then, to the rescue of the Germans, came a sudden thaw. This, indeed, increased the difficulty of bringing up the reserves which they had scraped together so painfully, but incomparably worse was the plight of the attackers in this melting of snow and ice. Their second and culminating attack on March 26, according to the German reports, was choked literally "in mud and blood." Towards the end of March the Russian spring offensive of 1916 died away, without ever getting beyond the local success on Lake Narocz. Their losses were estimated by the Germans at 150,000 men, while the Germans sacrificed not more than 15,000.

On April 28 1916 the troops of the German X. Army under Gen. von Eichhorn snatched from the Russians the greater part of that tract of country which they had captured during the March battles in the confined area of Lake Narocz.

*The Luck (Luis) Campaign, Summer of 1916.*—At the conference held on March 18 1916 the Allies had fixed July 1 for the opening of the great general offensive on all fronts. For this the Russian Supreme Command was now making ready. By the end of May all their preparations pointed to the probability of their decisive attack again being made N. of the Pripet marshes, and again on the German front. Of the 130 Russian divs., comprising over 2½ million rifles, as to which the Austro-Hungarian and the German intelligence service had accurate reports, 74 to 77—or less than two-thirds—were in the northern section. On the side of the Central Powers there were at the same time on the eastern front 83½ inf. divs. and about 20 cav. divs., each cav. div. counting almost as many rifles as one regt. of inf., and often fewer. Altogether these amounted to 600,000 fighting men for the Germans and the same number for the

Austro-Hungarians. The distribution of forces was the same as in the beginning of March.

In the middle of May the Austro-Hungarian offensive against Italy had started, meeting at the beginning with great success. Once more the Russians were faced with the necessity of relieving their hard-pressed allies, and at least preventing any further transference of Austro-Hungarian fighting forces to the Italian front. Now the preparations for the Russian attack were not yet complete. Also it was evident that active relief to the Italians could only ensue from an attack, not on the German, but on the Austro-Hungarian eastern front—that is, between Pinsk and the Bessarabian Pruth. The Russian Supreme Command were not easily induced to depart from their original plans of to attack prematurely before July 1. In the end, however, they had to yield to the pressure of the Allies. Gen. Brusilov, supreme commander of the Russian "south-west front," with the Quartermaster-General, Gen. Dietrich, as the real source of energy at his side, received the order to advance to the attack from Rovno down to Bessarabia. The very first assault, made with attack groups that had been got together at haphazard, brought Brusilov great and unexpected success on both wings in the battles of Luck and Oena, although the defenders were not unfavourably situated as regards numbers. Thereupon the Russian Supreme Command decided to refrain from the great attack on the German front altogether and transfer the centre of gravity of their operations to the southern section. The advances on the Russian side during the next three months, at Riga, Jakobstadt, Dvinsk, Smorgon and Lake Narocz, were therefore undertaken only at odd moments, without any successes worth mentioning, and must be treated simply as demonstrations. But meanwhile Brusilov had snatched from the Central Powers large portions of Volhynia and East Galicia and the Bukovina.

*Battle of Baranovichi (Baranovische).*—On the other hand, the objective of the Russian Supreme Command in the three battles at Baranovichi had a close connection with the operations at Luck. In the first battle, on June 13 and 14 1916, the attacks led by Gen. Ragosa and Lesch failed completely. Gen. Woyrsch maintained the upper hand over the Russian grenadiers with his Silesian Landwehr. The Germans lost 150 men, the Russians 7,000. In the second battle, on July 2-7, the Russians put in 16 of their divs. against the 2½ German and 4 Austro-Hungarian divs. holding the section Gorodishche (Horodyszczce)—Baranovichi. The Russian main blow fell on the Austro-Hungarian XII. Corps under Gen. von Henricquez, and forced it back to the second position. German Battalions were hastily scraped together to reinforce their hard-pressed allies. There were critical hours and critical days. But on the last two days of the battle the greater part of the ground captured by the Russians was torn from them again. East of Baranovichi Gen. Ragosa's troops were fated to achieve only unimportant local successes. The defenders lost—in dead, wounded and missing—180 officers and 8,000 men; the attacking Russians many times this number.

For the third time the battle of Baranovichi blazed forth on July 25 1916, this time as an introduction to the great Russian general attack N.W. of Luck. Once more the Russians flung themselves against the Gorodishche section, but were driven back by the Germans after a fierce three days' fight.

*Operations in the Summer of 1916.*—The Russian offensive in the beginning of June 1916 brought the attention of the Central Powers with a jerk to the eastern front, where all at once the situation had become extraordinarily tense, and the anxiety became all the greater with the reflection that the results in the other theatres of war had not come up to their expectations. The Verdun undertaking had cost the Germans heavy sacrifices without making them masters of the fortress, and it was but a small consolation to know that the French had bled even more than they. On the Somme an English-French attacking force of prodigious size and fighting strength was massing itself. In the Venetian mountains at Asiago, the Austro-Hungarian corps, though it was still attacking, had lost much of its momentum since May 25. A pause in the fighting at the end of that month

had given the Italians an opportunity of flinging powerful masses of troops on to the hard-pressed mountain front, thus averting catastrophes for the time being.

The turn of events in the east called for new decisions, and a few days after Luck the two chiefs of the General Staffs of the Central Powers met in Berlin to form these decisions. The idea of leaving the eastern front—in Falkenhayn's words—"to look after itself" was, it may be assumed, only theoretically discussed. Neither did such resolutions come under consideration, either then or later, as those executed in 1914 by the Central Powers when they shook off the enemy by one mighty move backwards and thus again deprived him of the initiative. The scarcity of food alone, under which the peoples of the Central Powers were already beginning to suffer heavily, made it imperative to cling to every foot of fruitful soil in Volhynia or East Galicia at all costs. On the other hand, the situation was so grave on all other fronts that for the moment any assistance proposed for the eastern front must be of a modest order. The commanders of the armies fighting against Russia indeed attempted, even within their own areas, to keep their forces together for use as units rather than to use them to fill up gaps. Gen. von Linsingen, for example, made frequent efforts in the area of his own group of armies at Luck to concentrate strong forces for counter-attack. But the strength of these attack-groups, in most cases, very soon exhausted itself against the numerical superiority of the enemy. Similar attempts were made several times in East Galicia and also in the Carpathians. Mention should be made in this connexion of a plan formed in the beginning of July 1916 to form a XII. Army out of the German and Austro-Hungarian troops in East Galicia and to attack with it on both sides of the Dniester. This idea certainly promised success; but the divs. selected for the purpose were, in view of the new increase of the Russian attacks, in most cases diverted to some particular danger-spot on the wide-spreading defence front; and the construction of the XII. Army, together with the task to be entrusted to it, had to be given up. There was nothing for it but to persist in the method practised since the middle of June, and contest every inch of ground in dogged local defence-battles. And even this mode of warfare was conditional on a considerable expenditure of force. Between the beginning of June and the end of Aug. about 17 German divs. had to be brought over from France and 8 to 10 Austro-Hungarian divs. from Italy. In addition, the front to the N. of the Pripet transferred a large portion of its regts. and divs. to the southern section, receiving in exchange only worn-out troops.

Since the beginning of July 1916 the Russians had also withdrawn strong forces from Kuropatkin's and Ewerth's fronts to add them to Brussilov's. Finally, at the beginning of Sept. the area S. of the Pripet, with 71 divs., had 20 divs. more than the northern section. The attacks during the summer offensive of 1916 cost the Russians enormous bloodshed. Great as were the results, the sacrifices far outweighed them. The Russian Supreme Command remained true to the methods practised in the Carpathians. It is quite impossible to point to any great conception underlying the operations of the Russian Command in these battles. They worked on purely local considerations and prospects, and often did not even make use of these, as for instance immediately after the first great blows delivered at Luck, when they gave their opponents time to close a gap of 50 km. which had been made. More than once did the Russian Supreme Command let slip an opportunity of a mortal blow.

*Creation of the "Hindenburg Front."*—The great crisis on the eastern front, lasting several months, reacted strongly on the relations between the armies of the Central Powers. The Austro-Hungarian troops had, from the very first Russian attacks, shown considerably less power of resistance than the German. The Austro-Hungarian armies fighting at Luck and Ocna had, within a few days, left a quarter of a million prisoners in the enemy's hands. Even in peace-time the conditions in the polyglot Dual Monarchy were less favourable by far than those in the German Empire for a display of military power, and the unexpectedly long duration of the war increased the

difficulties enormously. It should also be remembered that in the first year of the war the Austro-Hungarian military forces had had a considerably larger drain on their men than the German. At the end of 1915 only a small remnant of the forces deployed at the beginning of the war was left at the front. The rest was dead, wounded or prisoners. In the quiet period before the Russian summer offensive of 1916 the training of the drafting reserve was certainly better organized than in the first year, when recruits had on occasion to be sent to the front after a month's training. But between the young, systematically trained peace-time forces, full of heroic self-sacrifice, with which the war started, and the Landsturm troops of the later campaigning years, some of them physically and morally unsound to begin with and many of them far too old, there could be no comparison. This was particularly the case with a considerable proportion of the Slav and Rumanian forces, on whom the great national crisis could not act as a spur but rather as the reverse, as was not infrequently proved. Under these difficult conditions the lack of good regular officers was most keenly felt. The flower of these had been left on the battle-fields of 1914.

In consequence of the internal weakening of the Austro-Hungarian army in the east—which was not noticeable in anything approaching the same degree where the army was opposed to its "hereditary enemy," Italy—a rule was made that on every point of the battle-front where the Russians were using great pressure German units should be flung in. In this way, from the beginning of July, the whole Austro-Hungarian section was interspersed with German troops. This system of "stay-boning," as it was sarcastically called, naturally brought with it a powerful increase of German influence in the combined army. It also happened that the Austrian leading provoked frequent criticism on the part of the German command. Immediately after the first Russian assault at Luck, for instance, the commander of the IV. Army, Archduke Joseph Ferdinand, was relieved of his command on the explicit demand of the German General Staff. Added to this, between the new commander and his Austrian subordinate commanders intermediate posts were interposed and filled by German generals, who also exercised direct power of command over the troops. As the number of German forces on the Austro-Hungarian front increased, the ambition of the Germans to get the principal commands into their own hands became more and more evident. Immediately after the beginning of the Russian offensive, the area commanded by the German Gen. Linsingen, which began on the Pripet, was extended to the boundary of Galicia. At the same time Falkenhayn proposed to entrust Field-Marshal Mackensen, who was in Bulgaria, with the supreme command of all the allied troops fighting S. of the Pripet. Conrad von Hötendorf was opposed to this arrangement, but offered to confer on Mackensen the command of a group of armies in East Galicia. This Falkenhayn declined.

In July Falkenhayn made the proposal to recall Field-Marshal von Hindenburg from Kovno and appoint him supreme commander between the Pripet and the Dniester. To this plan Conrad agreed, though without seeing any particular meaning in it. As a matter of fact Falkenhayn's proposal was made more on personal than on practical grounds. The chief of the German General Staff had from the start few friends but many enemies. Since the failure of the attack on Verdun, Emperor William had begun to be besieged with complaints against the man who had his particular confidence. The Imperial Chancellor also urged that Falkenhayn should be replaced by Hindenburg, with a vigour quite unusual with him. The summer battle made the situation more acute. A depression fell over Germany, the army lost faith in the Supreme Command, and louder and louder became the clamour for Hindenburg.

Falkenhayn, though realizing that his relations with Hindenburg and Ludendorff had been somewhat strained for more than a year past, felt obliged to fall in with the general opinion. He therefore proposed—assuredly more or less against his inward conviction—that Hindenburg should receive the appointment alluded to, that of supreme commander from the Pripet to the

Dniester. This he followed up a few days later, under pressure from all sides, by offering to place the Field-Marshal in command of the whole eastern front from the Baltic Sea to the Carpathians. For some such unity of command there was urgent need on military grounds. Indeed the proposal had received a passing consideration in Nov. 1914, when the Archduke Frederick was to have held the command with Ludendorff as his chief-of-staff. But Conrad was opposed to this solution, arguing that the Russian assaults were not to be stopped by new commanders but by strong battalions, that the non-German peoples and troops of the Austro-Hungarian Monarchy would regard any too conspicuous manifestation of German influence as a burdensome tutelage, and finally that in the southern section of the eastern front so many specifically Austrian interests were at stake—in particular with respect to the danger from Rumania—that this section ought not to be withdrawn from the immediate influence of the Austro-Hungarian Higher Command. But, however worthy of consideration Conrad's objections may have been, it is only human to suppose that personal grievances also played their part. The solution proposed by Falkenhayn was tantamount to making a clean sweep of the Austrian General Staff from the command of the war in the east. Yet, the leader of the Austro-Hungarian army was practically alone in his opinion. Even in those Viennese circles most jealously concerned to uphold Austrian prestige there was a pressing demand to have the question of the command straightened out on German lines, since Conrad's leadership no longer inspired full confidence. In principle the old Emperor, Francis Joseph, agreed also. Emperor William, for his part, proposed a compromise to his allies. Hindenburg was certainly to have supreme command from the Baltic Sea to Lemberg, by far the greater portion of the eastern front, but the southern portion on both sides of the Dniester and in the Carpathians was to be placed under the command of the Austrian heir-apparent, Archduke Charles Francis Joseph, who later became emperor. The Archduke had been fetched from the Italian front to take over the command of the XII. Army, and now, since this army had not come into being, was temporarily commanding a group of armies on both sides of the Dniester. To protect German interests the German Gen. von Seeckt, formerly Mackensen's chief-of-staff, would be attached to the Archduke. This solution was accepted by the Austrians and acted upon in the beginning of Aug. 1916. It was the prélude to the establishment of a Supreme War Command (*Oberste Kriegseleitung*) over all fronts.

The impulse to create a general supreme command of this nature, to apply to all fronts, emanated from Sofia and Constantinople. Germany was agreeable to the proposal, which also gained ground rapidly in Vienna's political circles, but here again it was Conrad who, in defiance of his superior commander, Archduke Frederick, sharply opposed the idea, even threatening to resign. Emperor Francis Joseph's personal intervention alone was able to overcome this opposition. On Sept. 16, 1916 the agreement on the *Oberste Kriegseleitung* was signed in the German headquarters at Pless in Prussian Silesia. According to these arrangements, shortly after acknowledged as binding by the Bulgarian and the Imperial Ottoman Army Commands, the German Kaiser became responsible for the higher leading of operations in general without disturbing the relations between the allied sovereigns and their fighting forces. The Kaiser was assisted by the chief of the General Staff of the German armies in the field, who before every important decision was to consult the chiefs of the allied General Staffs and, as far as possible, bring them to an agreement. This done, the German chief of the General Staff would issue orders, binding on all, in the name of the *Oberste Kriegseleitung*. In order to meet Conrad's particular misgiving the German Kaiser bound himself, in a special supplementary note which was kept secret from Sofia and Constantinople, that the integrity of Austria-Hungary should be as carefully protected as that of Germany.

The institution of the *Oberste Kriegseleitung* was undoubtedly an advance on the method of dealing with each case as it arose, which had been practised since the beginning of the war. But

the undertaking, set on foot with such difficulty, still lacked one thing to complete it—the creation of a common political and domestic policy. This was never achieved. On the contrary, the forces involved in these matters fell farther and farther apart the longer the war lasted, particularly after the change of Government in Austria-Hungary. To make matters worse; when the young Emperor Charles took over the Austro-Hungarian command, alterations were made in the most important parts of the agreement in consideration of his position as sovereign, so that in the end the old methods employed in the first two years of the war came back into use.

*The New German Supreme War Command (Oberste Kriegseleitung).*—The agreement on the Supreme War Command had been signed on the part of the Germans by Field-Marshal von Hindenburg as new chief of the General Staff. On Aug. 29, 1916 Falkenhayn had left the Supreme Command. It had long been only a question of when the Kaiser would be forced to yield to the storm raised by Falkenhayn's critics; the immediate cause of his dismissal was Rumania's declaration of war on Austria-Hungary on Aug. 27, 1916. Up to the last hour, in spite of the well-founded warnings of Austria-Hungary, Falkenhayn had been unable to believe that Rumania was on the point of coming in, and had perpetually reassured the Kaiser to that effect. When the event happened the Kaiser was thunder-struck, and Falkenhayn's fall followed. The German nation and its allies greeted the new men, Hindenburg and Ludendorff, with the utmost confidence.

The first task to fall upon the new command was the organization of the Rumanian campaign (see next section). Meanwhile the defensive battle against Russia had to be carried on. This constantly flamed up again along the whole front from Luck to the Carpathians till the end of Oct., although the Russian attacks had fallen off in strength and determination, and no more successes worth mentioning were gained by them. The relief offensive, too, which the Russians undertook between Nov. 28 and Dec. 13, 1916 in the Wooded Carpathians against Kowetz and Arz's armies, to relieve Rumania, hard pressed in Wallachia, was without results and could save neither Bucharest nor Focshani. Neither did success attend the Russian surprise attack on Jan. 23, 1917 on the Aa at Riga, great as were the prospects of success on the first day. The German position was indeed rushed, but the defenders' reserves, brought up in haste, restored the situation.

The enormous drain on Russia's forces in the summer, and the difficulties of her interior political situation, had sapped the marrow of her army. The armies of the Central Powers and their allies had come through their difficult crisis. As in the end of 1915 and the beginning of 1916, so now they experienced a great relief in the east.

*The Russian Revolution.*—The Austro-Hungarian chief of the General Staff, Conrad, who since Nov. 11, 1916 had been a field-marshal, was once more proposing to take the opportunity of attacking Italy. The attack was to begin in the spring of 1917 and was to be carried out by an equal division of Austro-Hungarian and German forces. But the new German *Oberste Kriegseleitung* in the middle of Jan. rejected the plan for the time being. They relied on the ruthless submarine war, begun in Feb. 1917 to bring their enemy to his knees. Gen. von Arz, who had succeeded Conrad as chief of the Austro-Hungarian General Staff in March 1917, received the decision of German Headquarters with unqualified approval. The Russian Revolution, which broke out in the middle of March, was extraordinarily favourable to the military situation of the Central Powers. It could not, of course, be seen as yet whether Russia's armies would permanently withdraw from the list of enemies, which now included America. But for the moment the crash was so enormous that it must be months before the Russian High Command could consider offensive operations. The Central Powers now left nothing untried that could hasten the process of disorganization among their enemies. This purpose was above all to be served by an extensive peace propaganda, which was to be carried to the Russian trenches—though Ludendorff's consent



to this step had not been easy to obtain. Meanwhile the war fell practically fast asleep, as was natural. On April 4 1917 the troops under Prince Leopold of Bavaria, who had taken over the eastern front between Riga and the Carpathians from Hindenburg in the autumn of the previous year, captured the small Russian bridgehead, Stochod, at Tobol in Polyesie, by a *coup de main*, on which occasion the Russians gave themselves up as prisoners in swarms. On the political circles of the Imperial Powers this action produced a most disturbing impression, and the troops were now ordered to suspend all hostilities against the Russians unless they should provoke them.

In preparing the line to be taken with regard to propaganda in the trenches, the Austro-Hungarian Government would have liked to make use of the Petrograd catch-words, "Peace without annexation or indemnity" and "the right of nations to self-determination." But the dominating influence of the German Supreme War Command, which was not prepared to give up its Balkan aspirations in a hurry, prevented this. Nevertheless it was hoped, especially when the Workmen's and Soldiers' Councils became a stronger political factor in Petrograd in the beginning of May, that a way might be found to force Kerensky's Government to agree to an armistice and consent to open peace negotiations. This hope was to prove deceptive. When at last an envoy from Prince Leopold of Bavaria succeeded in penetrating beyond the Russian trenches to Gen. Dragomirov, commander of one of the armies on the north front, he was met with an absolutely unequivocal refusal. Meanwhile, at numerous points of the front, a local truce had been declared. But in June a remarkable change was noticeable on the Russian side. Kerensky, relying on Gen. Brusilov and numerous Entente military missions, succeeded gradually in converting a considerable portion of the army to the idea of carrying on with the war to make the world "safe for democracy," and in restoring their fighting spirit.

*Battles in Galicia and the Bukovina, Summer of 1917.*—By the end of July the Army Commands of the Central Empires had reason enough to count upon a revival of the war in the east. Indeed, the Russian Supreme Command, apart from the concentration of troops at Riga, Dvinsk and Kriewo<sup>1</sup> in the Courland-Lithuania section, had assembled two powerful attack groups in East Galicia. The one, a division strong, stood N.E. of Brzezany opposite the Austro-Hungarian II. Army (Böhm-Ermolli); the other, 15 inf. and 2 cav. divs. strong, was piling itself up adjacent to the first and opposite the German Southern Army under Gen. von Bothmer.<sup>2</sup> These powerful attack-masses were charged to overthrow the enemy and to take Lemberg.

The Army Higher Commands of the Central Powers did not look on idly at the Russian preparations for attack. By June 27 the German Emperor, in concert with the Austro-Hungarian General Staff and Prince Leopold of Bavaria, was ready with the order to counter-attack in case of a Russian attack in East Galicia, and to throw back the enemy beyond the frontier of the Austrian Empire. Besides the allied troops already on the spot, 5 divs. could be brought up from the west and 3 to 4 divs. from that section of the eastern front which was not threatened.

*Battle of Brzezany, July 1-6.*—The anticipated Russian attack was launched on July 1 1917 on both sides of Brzezany. The Western Powers had supplied their Russian allies with artillery, munitions and war supplies of all sorts in abundance. The battle of Brzezany lasted six days with only slight interruption. The Russians made only slight gains in fighting the German Southern Army E. and S. of Brzezany, and these were for the most part wrested from them again. N.E. of Brzezany, in the village of Koniuchy, they were more successful. Here they had brought into the fight a Czechoslovak brigade against Austrian battalions of Slavonic speech, large sections of which surrendered, with the result that the Austro-Hungarian line was driven back

<sup>1</sup> At Kriewo the Russians actually attacked with 20 inf. divs. on July 23 and 24; forcing back the German front a few deep along 4 km. of front.

<sup>2</sup> The designations "Austro-Hungarian II. Army," "German Southern Army," etc., refer only to command and staff. The troops were thoroughly mixed on the whole of the eastern front.

some 4 or 5 km. on a front of 10 km. On the evening of the second day of the battle, however, the Russian blow was countered by the German troops. Since, to the immediate N. of the battle-field and N.W. of Zborów, the first echelons of the German army, rolling up for the counter-attack had arrived, and the Russian attack had so lost its force, Prince Leopold of Bavaria now supposed the danger to be averted.

Far more unpleasant was the effect upon the command of the heavy set-back to the Austro-Hungarian III. Army under Gen. von Terstzyansky at Stanislaw only a few days later. Here Gen. Kornilov, the ambitious commander of the Russian VIII. Army, had advanced to the attack at 7 A.M. with an attack-group thrown together anyhow. On the following day he already held in his hand the key to the enemy's position—the Jutrena Gora height dominating Stanislaw. Terstzyansky hoped at first to have to withdraw the north wing only, but the Russians pushed the Austro-Hungarian regiments back so vigorously that by July 11 the whole of the III. Army had to be withdrawn behind the Lomnica. The town of Stryj, and the East Galician petroleum district, Drohobycz-Boryslaw, on the possession of which the continuance of the submarine war very largely depended, were in the utmost danger, and Prince Leopold of Bavaria was forced to let 3 inf. and 1 cav. divs. of the units rolling up for the counter-blow be diverted to the III. Army.

When the Russians again attacked at Kalisz and made progress there, Prince Leopold and his chief of the General Staff Col. Hoffmann, were confronted with the difficulty of deciding whether in the given case the counter-blow at Zborów, already being prepared, should be given up, and help sent in haste to the sore-pressed Gen. von Terstzyansky. The Prince resolved to adhere to the original plan. He proved to be right. The attack of Kornilov's troops lost their sting as rapidly as those delivered at Brzezany by the Russian VII. Army. Aided by German reinforcements, Gen. Kriek, who relieved Terstzyansky in the command of the III. Army, was able by the 16th to prove his troops' newly established powers of resistance in counter-attacks at Kalisz.

Meanwhile, between the upper Sereth and the railway line between Lemberg and Tarnopol, immediately W. of Zborów, 8 inf. divs. (including the I. and II. Guard Divs.) and a combined cavalry div. were deployed for the counter-blow along 25 km. of front behind the divisions of position. The German Gen. von Eben was in command on the battle-field. The intention was on the first day to make a hole in an easterly direction, in the south wing of the Russian VIII. Army which stood opposite, and then to wheel to the S.E. and grip the massed Russians of the VII. Army standing on either side of Brzezany, in the N. flank and in rear.

*The Battle of Zborów.*—This idea, underlying the battle of Zborów (July 19-26 1917) was carried out according to plan. Early on the 19th the German and Austro-Hungarian forces drove the Russians from the Zlota Gora height, N. of Zborów, under the eyes of Prince Leopold of Bavaria. Simultaneously the German Guard, reinforced by a line division, broke through the Russian front immediately S. of the Sereth. Only in places did the Russians offer resistance. Their retreat frequently degenerated into precipitate flight. While the Guard Div. in the following days drove down on Tarnopol, the divs. brought forward from the 2nd line pressed after in a S.E. direction. The Russian masses at Brzezany were soon swept into the general retreat. By the 22nd the German Southern Army was able to take up the pursuit; also from the N. wing. On the 23rd the III. Army followed (S. of the Dniester, and was able on the next day, after several fights, to push out to beyond its old position at Stanislaw. On the 25th the German Guard took Tarnopol in presence of the German Emperor, and on the 26th the heights to the E. of it; thus assuring an adequate protection to the S.E. blow by the other allied forces. The S. wing of the II. Army was already beyond Tarnobrzeg, and the Southern Army beyond Brzezany. They had rapidly broken the Russian resistance.

A few days after the defeat of Zborów the Russian command passed out of Brusilov's hands into those of Kornilov. The

EASTERN EUROPEAN FRONT

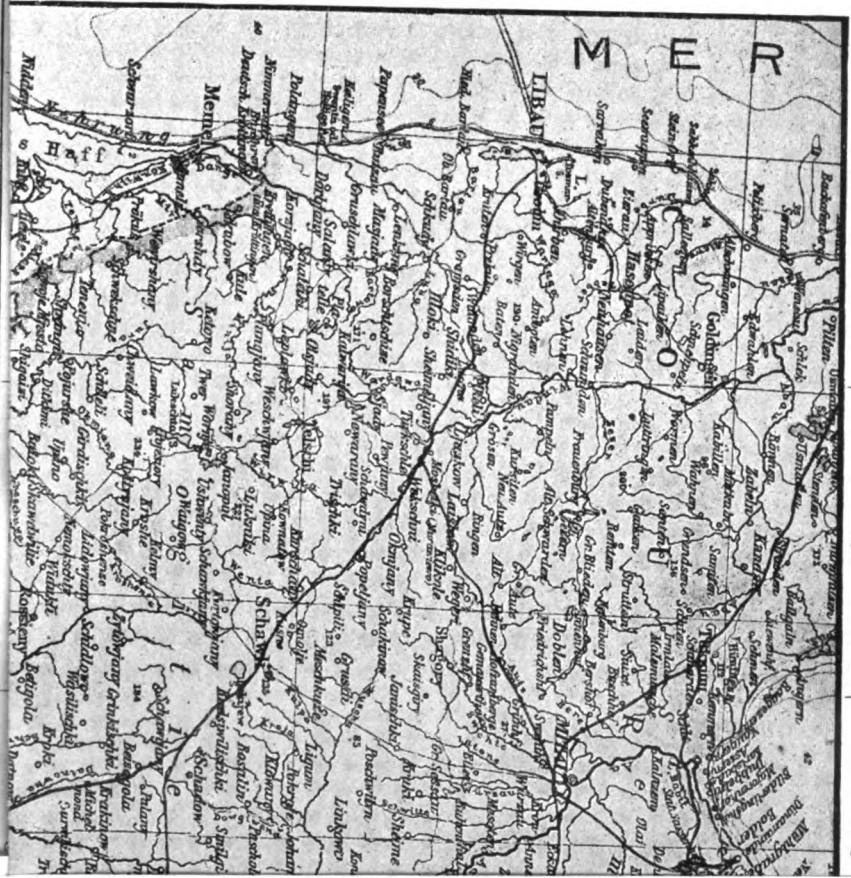



Russian General-Staff reports of those days give a tragic picture of the condition of the VII. Army and the S. wing of the VIII. Army at that time. It was clearly out of the question to maintain a hold on East Galician soil in this area. The decision was therefore made at Mohilev to withdraw the VII. Army and those parts of the VIII. Army pursued by the enemy behind the river Zbrucz on the frontier.

**Capture of Czernowitz by the Austrians.**—More cheering were the reports received by the Russian Supreme Command from the VIII. Army now commanded by Cheremissov, which was retiring S. of the Dniester. This army could, with some hope of success, be charged to hold Czernowitz and as much as possible of the Bukovina. Further relief was expected from the results of the Russian-Rumanian attack in the valley of the upper Susita in Rumania, which had commenced on July 23 and was accompanied by demonstrations along the whole Transylvanian east front. This attack had really succeeded by July 27 in forcing back the numerically very weak defenders to a not inconsiderable distance. But the fate of the Bukovina was nevertheless sealed. Between the Dniester and the Carpathians Cheremissov's troops several times put up a good resistance; in fact, the Austro-Hungarian III. and VII. Armies (the latter under Gen. von Kávess) had even to deliver counter-blows. But on the morning of Aug. 3 1917 the Russians, threatened on the N. and the S., had to surrender Czernowitz, and soon to retire from the Bukovina into the frontier area. The Austro-Hungarian III. Army pursued between the Pruth and the Dniester and the VII. S. of the Bukovina.

East Galicia had also been swept clean of the Russians, apart from the area N.E. of Tarnopol which had remained untouched by the offensive. Advanced detachments of the German Southern Army had set foot on Russian soil on the middle and lower Zbrucz. But here the soldierly characteristics of the Russian people, which had survived even the unerring influence of the revolution, came to the fore again. The Russians not only cleaned the E. bank of the Zbrucz, but roused themselves in an amazing manner to renewed resistance E. of Czernowitz and in the southern part of the Bukovina. It was undoubtedly to their advantage that the enemy in his rapid advance had come dangerously far away from his railways. The Austro-Hungarian III. Army at Czernowitz for instance was 120 km. removed from its main detrainment station lying W. of Stanislaw. This was particularly serious in view of the meagre means of transport supplied to the Austro-Hungarian troops. Had the armies been crossing a less fertile area the pace of the offensive must soon have slowed down very considerably. As it was the troops could subsist largely on the resources of the country and the rich booty left behind by the Russians. But now, on the frontiers of East Galicia and the Bukovina, the advance of the Imperial forces was arrested.

**The Battle of Marasesti (Marashkethi).**—For some weeks past the Allied Higher Commands had been considering the idea of combining with the East Galicia offensive an attack on the Rumanians in Moldavia, which should drive them behind the Pruth, thus gaining a particularly useful defence section in which troops could be economized. Accordingly, on Aug. 6 1917 Mackensen advanced to the offensive against the Rumanians N. of Focshani. The battle of Marasesti ended unfortunately for the forces of the Central Powers. In view of this, and of the difficulty of obtaining fresh drafts in the Bukovina, the Central Powers abandoned the idea of occupying Moldavia for the present, and dropped it completely when, at the end of Aug. and the beginning of Sept., the Isonzo battle led to the combined Oct. offensive against Italy. Ludendorff lays stress, in his memoirs, on his own reluctance to give up the Rumanian campaign.

In the Bukovina and on the Transylvanian-Rumanian front minor operations lasted until the middle of September. Local attacks and counter-assaults were distributed on both sides. Then gradually the fighting died down.

**German Capture of Riga.**—Meanwhile, in the extreme N., the Germans had won a fresh victory over the Russians. During the second half of Aug. they had been quietly preparing to cap-

ture Riga. By order of Gen. von Hutier, supreme commander of the German VIII. Army, 6 divs. were placed in readiness for crossing the Dvina opposite Ūrküll, to the S.E. of Riga. Other forces were to follow. Altogether there were 14 divs. available for the undertaking, including the Guard and other units brought from East Galicia.

The crossing at Ūrküll was carried out most punctually on Sept. 1 1917. By now 3 bridges had been built. The Russian XII. Army (Paraki), 20 inf. divs. strong, made only a slight resistance, and by the 2nd had evacuated all the positions S. of Riga. On the following day the 2nd Guard Div. and the 1st Res. Div. were able to enter the ancient Baltic trading-centre, the one from the east, the other from the west. The Russians now evacuated the whole N. bank of the Dvina up to beyond Friedrichstadt. On the 4th the German infantry reached Hinzenberg railway station, 40 km. N.E. of Riga. The permanent position was now formed along a line drawn from Ūrküll to Hinzenberg and thence westwards to the sea. Only the German cavalry now pursued the enemy, who first came to stand 20 to 40 km. E. and N. of the German line.

The occupation of Riga needed to be supplemented for the Germans by the capture of the Baltic islands, Ōsel, Moon and Dagö, and this was duly achieved in the middle of October. For the first time in the war, on the side of the Central Powers, the navy was present in some strength to assist in the operations of the land army. The landing corps consisted of the German 42d Inf. Div. and the Cycle Bde., and was commanded by Gen. von Kathan. The spot selected for the landing was Tagga Bay on the N.W. corner of Ōsel Island. While Adml. Erhard Schmid's German squadron penetrated through the Domesnis straits, after silencing the coast batteries, the torpedo boats went round Ōsel in a northerly direction, in order to bring their guns to bear on the mole connecting Ōsel with Moon and to cut off the retreat of the Russian troops on Ōsel. From the N. they were to press on into the Moonsund. On Oct. 15 the German troops landed in Tagga Bay. The enemy, about one div. strong, tried to effect their escape, some southwards to the Sworbe Peninsula, others over the mole to the island of Moon. By evening on Oct. 16 the whole of Ōsel was in possession of Gen. Kathan. Ten thousand Russians were taken prisoners, among them one divisional and three brigade staffs. On the 18th Lt.-Gen. von Estorff, advancing over the mole, occupied the island of Moon, and on the 1st Dagö had also been taken by the Germans. In the waters of Moon it came to fighting engagements between German and Russian ships, in the course of which the Russian battleship "Slava" was set on fire.

**The Armistice.**—On Nov. 7 the Bolshevik Revolution broke out in Russia. On Nov. 9 the congress of the "Workmen and Soldiers' Council," meeting at Petrograd, issued its proclamation of peace "to all." In vain did Kerensky and Kornilov attempt to give matters a different turn. An army corps sent by them against Petrograd on Nov. 12 was defeated at Tsarkoye Selo. On the 20th the Council of People's Commissaries gave instructions to the new Russian Supreme Commander, Dukhonin, to offer an armistice to all the belligerents. As Dukhonin hesitated to carry out the order he was replaced by Ensign Krylenko. On Nov. 28 the troops of the Imperial forces on the eastern front intercepted a wireless message in which Lenin and Trotsky invited the earliest possible preliminary arrangements for the armistice and peace negotiations. On Dec. 2 the armistice negotiations between the Imperial forces and Russia were begun at Brest-Litovsk, at Prince Leopold of Bavaria's headquarters. The only questions which caused serious difficulty were that of the Baltic islands, which the Russians wished the Germans to evacuate at least in part, and that of the transference of German troops to the west. On the first point the Germans refused to give way; on the second they compromised. After a formal 10 days' truce had been agreed to on Dec. 5 and the armistice had set in on the Rumanian front on the 10th, the cessation of hostilities for one month on all the Russian fronts against the Central Powers was declared on Dec. 15. On Dec. 25 the peace negotiations at Brest-Litovsk began. (P. 12-13)

## V. RUMANIAN CAMPAIGN, 1916-7

*Operations in Transylvania and Rumania, 1916-7.*—After the unexpectedly great results of the Russian summer offensive under Brusilov in 1916 the conviction gained ground in Rumania that the moment had now come for her intervention on the side of the Entente Powers. In accordance with the policy pursued since the Balkan Wars of 1912-3 of harvesting from international quarrels the greatest practicable advantage with the least possible sacrifice, Rumania now hoped to be able to realize the desire, cherished by the entire nation, for the enlargement of the kingdom by the incorporation of the districts of Austria-Hungary inhabited by her nationals.

The Austro-Hungarian Supreme Command had foreseen most clearly the intervention of Rumania, while at German Headquarters the danger did not appear so imminent; and the Hungarian Government—fearing unrest among their own population and in the hope of not destroying the last chances of maintaining peace with Rumania—avoided taking in the threatened frontier districts the measures necessary in the event of war breaking out. Thus it happened that Transylvania was quite inadequately defended from the military point of view against the Rumanian attack, and the country was hardly prepared at all as a theatre of war. On account of the pressing need for all effective units on the Russian and Italian fronts, the Austro-Hungarian Supreme Command could transfer to Transylvania in the beginning of Aug. only the seriously reduced 61st Div., the 51st Honved Div., and the 82nd Inf. Regt., troops for which an urgently needed rest had been intended. The 11th Honved Cav. Div., disentrained in Transylvania, was at once constituted the southern wing of the VII. Army. The removal of the war-worn 30th Honved Div. began in the last days of Aug. 1916. In addition there were in Transylvania, at the end of Aug., 8 newly formed inf. batts., 2 Landsturm batts., 10 communication batts., 3 mining batts. (armed coal-miners from Petrozsény), 9 "alarm" batts. (march batts. not yet fully trained), about 5,000 frontier police, 3 Landsturm squadrons and 9 field batteries, which were formed into newly created larger units whose formation was, with many changes, only completed in Oct. 1916. All the troops above mentioned, in the areas between the Hungarian frontier of the Bukovina and the Danube at Orsova, were from Aug. 13 onwards under the newly created Austro-Hungarian I. Army headquarters, under Gen. Arz von Straussenburg, at Klausenburg (Kolozsvár). Preparations were also made for the thorough destruction in the passes, of the roads and railways leading to Rumania.

At the end of July a convention was concluded at Pless between the German, Austro-Hungarian and Bulgarian Army Commands for common action in case of hostile Rumanian intervention, and to this Turkey shortly afterwards became a party. The plan of campaign was laid down in its main outlines and the contingents to be provided by the separate States agreed upon. The Germans allotted 5 to 6 inf. and 1 to 2 cav. divs., which, however, the German Supreme Command in expectation of coming events did not yet wish to place in reserve in Transylvania, as they would certainly be missed at critical points on the other battle-fronts. They therefore confined themselves for the time being to sending German construction troops to strengthen the existing railway lines in Transylvania, S.E. Hungary and northern Bulgaria for the advance of larger bodies of troops. The German detachment under Kauffmann, already placed in northern Bulgaria with a view to the creation of a German-Bulgar-Turkish army on the Dobruja frontier, was reinforced, and had heavy artillery, mine-throwers and flying formations.

Bulgaria placed on the Dobruja frontier the III. Army, commanded by Gen. Toshev, consisting of the 1st, 4th and one-third of the 6th Inf. Divs., one cav. div., the garrison of Varna, and a part of the Kauffmann detachment, while the Danube was guarded from Tekija (opposite Orsova) to the mouth of the Vid by the Bulgarian 12th Inf. Div., and from there eastwards as far as Ruscuk by the German Kauffmann detachment. At

<sup>1</sup>A Bulgarian inf. div. had 3 bdes. of 8 batts., i.e. 24 batts. in all.

Sistova there was a heavy Austro-Hungarian bridging train with its complement of men, some heavy batteries, and the Austro-Hungarian Danube flotilla. The supreme command over all the troops in Bulgaria for operations against Rumania was exercised by Mackensen, with headquarters at Tirnovo.

It was considered most probable that Rumania, when she struck, would begin by invading Transylvania, in order to gain possession of the country and to use it as a base from which completely to shatter the Carpathian front, which the Austro-Hungarians, as it was, were only maintaining with difficulty, while comparatively weak forces only would be employed against Bulgaria. On this assumption it was proposed to surprise an overrun the Rumanian positions in the Dobruja with the German-Bulgar-Turkish forces, in order to penetrate to the narrow part of the district between the Danube and the Black Sea. The strongest possible forces would then be collected, and be ready at Sistova, where the heavy Danube bridging train was already placed, for a forward push in the direction of Buchares. In Transylvania the Austro-Hungarian forces were to hold up the Rumanians in the mountains on the frontier if possible, but at latest on the position prepared on the upper Maros and the Little Küküllö (Kleine Kököl), until the attacking troops being concentrated meanwhile could be marched up. These, and Mackensen's troops to be held ready at Sistova, would then proceed to the reconquest of Transylvania and the overthrow of Rumania. In this case the unusual happened, and the actual operations in their main lines were successfully co-ordinated as had been proposed in the discussion of war plans at Pless.

Rumania had pushed forward her mobilization, and by continuously reinforcing the troops on the Transylvanian border had so nearly completed their concentration that operations could begin immediately on the declaration of war, which was handed in at 9 P.M. on Aug. 27. It was intended first to conquer Transylvania. For this purpose strong forces were to push forward from the E. over the mountains on the frontier, and advance westwards through the valleys of the Küküllö, the K. Küküllö and the Maros. The calculations included a simultaneous push forward of the Russian front adjoining on the N. whose advance would be greatly facilitated by the offensive of the Rumanian army S. of the chain of the Carpathians stretching from Hungary into the Bukovina. The forces which penetrated the passes on the Transylvanian southern front were then to hold these by means of positions in the nature of bridgeheads and to join the forces of the main offensive from the E. as they advanced.

On the Rumanian side expectation of an easy victory prevailed. In conformity with the plan of operations there was a concentric advance. The I. Army (Gen. Culea), with about 4½ inf. divs. and 3 cav. bdes., and a stronger group on the E., advanced through the Roter Turm pass on Hermannstädt (Nagy Szekes) and with a weak group on the W. over the Vulkan and Szurdok passes in the line Petrozsény-Fátseg (Fátég). The Orsova group (about one-reinforced div.) on the Danube defended the left flank and the rear communications of the portions of the I. Army fighting in Transylvania against any advance from the Banat. The II. Army (Gen. Grainiceanu), with about 4 divs. and 4 cav. bdes., operated from the Torzburg to the Ojtoz pass through all the defiles leading into the Kronstadt (Brassó) basin and the Háromszék. The IV., or Northern Army (Gen. Prossin), with about 4 divs. and 1 cav. bde., operated N. of the II. Army and in connexion with the Russian Carpathian front through the Uz. Gyimach, Bekás and Tölgyes passes into the basins of the Csik and the Gyergyó. The III. Army (Gen. Averescu), with about 4 inf. divs. and 4 cav. bdes., faced Bulgaria on the Dobruja frontier in strong, well-fortified positions, and was to maintain the defensive. On the stretch of the Danube from Turnu Severin to the mouth of the Alt stood protecting troops, one div. strong. In the district S. of Bucharest the Rumanians assembled a group of several res. divs. and other new formations for disposition as reserves.

The Rumanian Invasion.—The Rumanians crossed the frontier on the night of Aug. 27-28 over all the passes into

Transylvania, driving back the weak Austro-Hungarian defence troops in numerous small engagements, not without suffering appreciable losses at many points. The Rumanian advance was substantially delayed by the destruction of roads and bridges effected by the Austro-Hungarian frontier troops, and especially by the bad roads of the mountain country.

By Sept. 3 the Rumanian Onsova group reached the lower course of the Cerna, and the western group of the I. Army occupied the important coal area between Utkikány and Pétroseny and had driven back the ineffective Landsturm and mineur battalions of the 144th Inf. Bde. over the saddle of Medsók. The eastern section of the I. Army, which had penetrated by the Roter Tarn Pass, occupied positions S. of Hermannstadt, without attempting to take the town though it was garrisoned only by a weak Landsturm detachment. They were plainly apprehensive that by occupying Hermannstadt they would have to extend their bridgehead-like formation beyond capacity.

The II. Rumanian Army deployed cautiously in Borsenland and to the Harbasmák, allowing their columns to close up, and receiving fresh reinforcements. The IV. Army forced their way, in continuous fighting touch with the 61st Inf. Div. through the narrow mountain valleys, and on Sept. 3 their advanced troops reached the eastern edges of the basins of the Gyergyó and the Csík. Meanwhile the first troops sent by the Central Powers were rolling up towards Transylvania. Gen. von Arz was instructed not to use the forces assembling on both army wings to strengthen the covering troops with them as they arrived, but first to concentrate them and hold them ready for wider action. In view of the expected continuation of the Rumanian advance he directed the 39th Honved Inf. Div. and what eventually, after many changes, became the 86th Inf. Div., to the district half-way between Szász Régen (Reghine-Sas) and Klausenbürg (Kolozevár); the 187th Inf. Div. and 3 German cav. regts. of the 3rd Cav. Div. were to be disentrained at Maris Illye; the 1st Austro-Hungarian Cav. Div. S. of this place between Hätzeg (Hateg) and Karansebes; the 1st Royal Hungarian Landsturm Hussar Bde. at Tóvis. The first of the two German General Commands to arrive, Lt.-Gen. von Morgen, took over the command of the 61st and 71st Inf. Divs., the 1st Landsturm Hussar Bde., the newly arrived 39th Honved Inf. Div. and the 86th German Inf. Div., while under Lt.-Gen. von Staabs were placed the 51st Honved Inf. Div., the 187th Inf. Div., the 1st Cav. Div. and the 3rd Cav. Div., together with the covering troops at Hermannstadt, Hätzeg and Mehadia. The very slow progress of the Rumanians made it possible for the incoming divs. of the Austro-Hungarian army to move forward their disentrainment stations. Accordingly the following disentrainment arrangements were made: the 39th Honved Inf. Div. at Szász Régen, the 86th Inf. Div. at Matosjvár, the 1st Cav. Troops Div. and the 3rd Cav. Div. (which had been united in the Schmettow Cav. Corps) at Mediasch and Elisabethstadt, the 187th Inf. Div. at Piski with a regt. intended for Hermannstadt at Alvincs.

Since the Rumanian group pushing northwards over Pétroseny might endanger the transport of further reinforcements on the Maros Valley railway, the bulk of the 187th Inf. Div. was directed against Merisor, in order, in conjunction with the Austro-Hungarian 144th Inf. Bde., and strengthened by the 3 first arriving German Jäger batts. of the Alpine Corps, to throw back the Rumanian Mountain Corps over the frontier; and this task was accomplished between Sept. 14 and 22.

The Schmettow Cav. Corps, linking up on the E. with the 51st Honved Inf. Div. standing directly N. of Hermannstadt, was posted on the heights N. of the Alt as far as Fogaras (Făgăraş). The Alpine Corps, which was only one div. strong but consisted of excellent troops, equipped for mountain warfare, was disentrained with the main body at Mühlbach. The German 76th Res. Div., which was on its way, was to be assembled at Karlsburg (Gyula Fehérvár). The Austro-Hungarian 143rd Inf. Bde., which had been stationed at Hermannstadt, was moved behind the N. wing of the I. Army, and there formed into the 72nd Inf. Div. These measures, taken by the II. Army Command, on the

one hand averted the menace to the Maros Valley railway at Piski; and on the other established the operative basis on which the battle of Hermannstadt was afterwards fought.

*Bulgarian Offensive in the Dobruja.*—Meanwhile events of far-reaching importance had taken place in the Dobruja. On Sept. 1 the III. Bulgarian Army crossed the Rumanian-Bulgarian frontier. The aim of the operation was the conquest of the Dobruja. After the capture of the bridge-heads of Turtucaia and Silistra the advance was to be made by the Cernavoda-Constanza railway to the narrowest part of the territory lying between the Danube and the Black Sea. The fortress of Turtucaia consisted of a girdle of 15 forts on the S. bank of the Danube; which were connected by strongly built field positions. While very great care had been bestowed on the technical development of the place during the 3 years of preparation, the armament, consisting of only about 100 guns, including the field artillery, was inadequate. Artillery fire against Turtucaia began on Sept. 31 in the comprehensive attacks following on Sept. 4 and carried out by the 4th and sections of the 1st Bulgarian Inf. Divs. and the German detachment under Hammerstein, the bridge-head was stormed. The capture of this place by a *coup de main* was an admirable feat of arms. Only a very small portion of the garrison of the place, the 15th and 17th Rumanian Inf. Divs., which suffered heavy and bloody losses, escaped. Many soldiers were drowned in trying to swim the Danube, across which there remained no bridge. Twenty-one thousand men and 400 officers, including 3 brigade commanders, together with the whole armament, were captured.

While the remainder of the Bulgarian 1st Inf. Div. pushed forward by Akkairtynar and the 1st Cav. Div. by Kurtunar, the 2nd Bde. of the 6th Inf. Div. and the garrison of Varna attacked the Rumanian 19th Div. on the plateau N. of Dobric (Hagi-Oglu) on Sept. 4 and threw them back northwards.

In contrast to Turtucaia the bridge-head of Silistra was in a state of unpreparedness. It fell on Sept. 9 into the hands of the cavalry of the 1st Div. after a short bombardment directed against the Rumanian cavalry.

While the Bulgarian III. Army was pressing forward successfully on the whole front, the retreating Rumanians were reinforced by the Russian Expeditionary Corps under Lt.-Gen. Zajaczkowski, which consisted of the XLVII. Corps with 3 and later 4 inf. divs., among them the 1st Serbian Div. (formed from Austro-Hungarian deserters) and the VI. Cav. Corps. The Bulgarian III. Army put their main weight in the advance in the space between the Danube and the Dobric-Medzidie (Hagi-Oglu-Megidia) line, while E. of the railway on the right wing only sections of the 1st Cav. Div. drawn from the centre of the army front operated.

On Sept. 15 the Rumanian-Russian fighting forces, which attempted to offer resistance on the line Lake Markeanu-Tekk Deresi-Karakli-Kara Omer-Mangalia, were attacked by the Bulgars and compelled to retreat along the whole line. The III. Rumanian Army, reinforced by hurriedly-brought-up Russian and Rumanian units, prepared to fight again on the position Rasova-Copadin-Toprui Sarl-Utkikij, which immediately protected the Cernavoda-Constanza railway and had been partially prepared in time of peace. The attacks executed by the Bulgarians on Sept. 10-20 did not penetrate the line this time. Instead, the III. Bulgarian Army Command were compelled to withdraw their troops some kilometres, to wait for the bringing up of munitions and the arrival of sections of the Bulgarian 12th Div., and the VI. Turkish Corps (25th and 15th Divs.). But the counter-attacks undertaken by the Rumanian eastern wing on Sept. 22 were repulsed by the recently arrived 25th Turkish Div., and the Bulgarian-Turkish front was again established on the line N. of Amuzia.

In the Dobruja generally operations for the time being came to a standstill.

*The Liberation of Transylvania.*—In Transylvania the IV. Rumanian Army advanced from the basins of the Gyergyó and the Csík through the Maros valley, then over the Górgény and Harghita mountains, and continuously pressed back the 61st



Inf. Div., subsequently reinforced by the 1st Landsturm Cav. Bde. It was feared that it would all too quickly reach the inner region of Transylvania, with its excellent communications. In that case it would threaten the rear of the 71st Inf. Div. which occupied positions on the W. bank of the Alt (Oltu) between Fogaras and Reps, and farther N.E. to Homorod and Okland, at the weak angle where the front of the I. Army from a direction W. to E. bent sharply from S. to N. Generally, too, it would deprive the covering troops of the possibility of protecting according to plan the picked attacking troops coming up to the front. The commander of the east front, Lt.-Gen. von Morgen, therefore, planned to make a surprise attack on the Rumanian IV. Army on its emergence from the G6rgény and Hargitta mountains, using for the purpose the concentrated strength of newly arrived units. He proposed to attack either from the area N. of Szász Régen (Reghina-Sas) southwards or from the upper course of the Great and Little Kukullo valley in a N. E. direction, and by pressing on the Rumanian communications to prepare an annihilating defeat for them. This plan, however, was not approved in higher quarters; it was determined merely to strengthen the E. front by hurrying up the Austro-Hungarian 72nd Inf. Div., and a more active conduct of the defence was recommended. Both Supreme Army Commands adhered to the original plan of concentration and to the idea of striking first at the inactive enemy S. of Hermannstadt.

Before daybreak on Sept. 15 the Rumanian II. Army crossed the Alt between Fogaras and Reps in several columns, for the most part without bridges or river transport, and advanced farther N.: from Bar6t, through Homorod-Okland-Draas towards Katzendorf. In order to make a mobile defence possible the 71st Inf. Div. had left only weak covering troops (about 3,000 rifles) on the 60-km. front, placing the main force in readiness in the district Petek-Mehburg. The weak defence naturally had to give ground before the far superior weight of the Rumanian attacking columns. But in the afternoon the main force of the div. made a surprise attack, advancing southwards through Pálos and struck the 6th Inf. Div., marching as the most northerly column of the II. Army, in flank and rear. The surprise and confusion of the Rumanians were so great that the II. Army, which had only just crossed the Alt, ceased to advance, and remained inactive for a week.

The Rumanian IV. Army, on the other hand, continued to advance steadily, thereby compelling the command of the I. Army to support the Landsturm Cav. Bde. by 4 newly formed Bosno-Herzegovinian inf. batts., which really belonged to the unit of the 71st Inf. Div. In addition the 39th Honved Inf. Div., N.E. of Maros Vásárhely, was pushed up to the front; the 89th Inf. Div. was advanced to Maros Vásárhely, and an inf. bde. of the 37th Honved Inf. Div., coming up without artillery, was placed in readiness at Teke, N.W. of Szász Régen. The newly arrived Austro-Hungarian VI. Corps Command took over the command of the N. wing (72nd Inf. Div., half the 61st Inf. Div. and half the 37th Honved Inf. Div.), while the I. Res. Corps Command retained command of the Landsturm Hussar Bde., the 39th Honved Inf. Div., the 71st Inf. Div., supported by the 19th Mountain Bde. of the 61st Inf. Div., and the 89th Inf. Division.

At the end of Sept. the IV. Rumanian Army in the N., with the reinforced 14th Div., had reached Déva in the Maros valley and Kásva in the G6rgény valley, and with sections of the 8th Div., was already pressing at Kibed on the Kukullo position. With the reinforced 7th Div. the west of Székely-Keresztur was reached, where the 19th Mountain Bde., already much weakened, could only defend itself with difficulty against the overwhelming pressure, while the 71st Inf. Div. on their left wing had definitely to give way.

On the evening of Sept. 17 Gen. Erich von Falkenhayn, with the staff of the newly formed German IX. Army, arrived at Déva, and took over the command of Gen. von Staabs' troops, and of all the reinforcements coming into this district. His commission was, in conjunction with the I. Army, to throw the enemy out of Transylvania, and for this purpose, while masking

the Vulkan and Szurdak passes, to surround the enemy posted at Hermannstadt, with a double ring, and beat him. Gen. von Falkenhayn first ordered Lt.-Gen. Sunkel, commanding the 187th Inf. Div. in the neighbourhood of Petroseny, who was about to push the Rumanians back to the frontier passes, after reaching this line to send all the troops he could spare from his div. and the Alpine Corps towards Hermannstadt; he ordered the assembly of the 187th Inf. Div. at Boussumarkt, of the Alpine Corps at Sinna, and the disentanglement of the 76th Res. Div. at Markt-Schelken. Finding by a reconnaissance in the direction of the Roter Turm Pass that the road was practicable for mountain troops without wheeled transport, he decided to direct the Alpine Corps by way of Cindroly and Preabe towards the Roter Turm, in order to hinder the retreat of the Rumanians by this route, while the 187th Inf. Div., the 51st Honved Inf. Div., the 76th Res. Inf. Div., and sections of the Schmettow Cav. Corps were to attack W. and E. of Hermannstadt in the direction of the northern outlet of the pass. This was not indeed a doubt encirclement of the enemy, as had been ordered by the Supreme Command, for which the forces of the eastern wing, when only a few squadrons could be made available, were insufficient. It was, however, a far-reaching enveloping movement against the one passable rearward communication of the enemy, in conjunction with an energetic attack on the front, of which the object was to destroy the group composed of the 2nd and 13th Rumanian Inf. Divs., under Gen. Popovici commanding the I. Corps.

On Sept. 25 Gen. Popovici attacked, but only attained success southward of Cornaticlu against the extremely thinly held positions of the 7th Cav. Bde. of the 1st Div., being everywhere else completely repulsed. The expected continuation of the Rumanian attack on Sept. 23 did not take place, and it was possible to issue orders for the projected battle. By Sept. 25 the XXXIX. Res. Corps with the 187th Inf. Div. were able to be assembled at the foot of the mountains S.W. of Hermannstadt, the 51st Honved Inf. Div. to the N.W., and the 76th Res. Inf. Div. to the N.E. of the town, while the Alpine Corps was to be within a day's march of the Roter Turm Pass. The general attack in the direction of the pass was to begin on Sept. 26; the Alpine Corps was to endeavour to reach the E. side of the pass in order there also to block the bridge-tracks leading over the mountains. The Schmettow Cav. Corps might, in the event of further pressure by the enemy, give way with its right wing, but with its centre on the Alt and its left wing towards Fogaras it was to hold its ground obstinately, and, in addition, if the operations proceeded according to plan, to arrange to push forward from the N.E. over the river towards the entrance of the pass. The I. Army Command was asked, as soon as possible, to place the 89th Inf. Div. in readiness at Schéssburg (Segesvár).

The Rumanians standing at Hermannstadt did not interfere further with the preparations for the attack; on the other hand the 11th Rumanian Div. stationed at the Szurdak Pass attacked again on Sept. 25, and regained possession of Petroseny. The 144th Inf. Bde., reinforced by two German battalions and two batteries, held the heights N. of the place. The IX. Army Command did not contemplate further reinforcement, but the unattached staff (i.e. without troops) of the German 301st Infantry Div. was sent there, under the direction of which were placed the 144th Inf. Bde. and the Austro-Hungarian and Mountain Bde., which had arrived on the 28th; and with these forces the Rumanians were again compelled to give up the extremely valuable coal basin.

*The Battle of Hermannstadt (Nagy-Sabben).*—On Sept. 26, favoured by beautiful autumn weather, the attack began, and it continued with undiminished violence against the obstinate defence of the Rumanians until the evening of Sept. 28. It ran on the whole, the course intended by Gen. Falkenhayn.

The Alpine Corps had already reached Roter Turm, Ra Vadulin and Căneni with their advanced troops on the road to the pass, early in the forenoon of Sept. 26. The Rumanians indeed now thoroughly realized the magnitude of the danger which threatened them, and delivered the most violent counter-attacks from N. and S. against the detachments of the Alpine

Corps. These troops might be temporarily pushed back at one point or another, but the road over the pass now lay continuously under German fire, which inflicted heavy losses on the Rumanian columns still attempting to break through. The Alpine Corps, however, did not succeed in reaching the E. bank of the Alt, and sections of the Rumanians were thus able to escape the threatened encirclement, and to cross the western spurs of the Fogaras Mountains.

The three divs. of the XXXIX. Res. Corps made a concentric attack between Orlat-Hermannstadt and the heights to the E. of it. It was only with difficulty that they at first gained ground, and not till Sept. 28 did they succeed in breaking the Rumanian resistance; but then, in consequence of the heroic endurance of the Alpine Corps, which made both escape and the bringing up of reinforcements from the S. impossible, the Rumanian defeat became a complete collapse. This collapse was precipitated when on Sept. 27 the 3rd Cav. Div. had succeeded, with two regts. of light horse, in crossing the Alt and narrowing S.W. of Porumbacu the circle of fire round the Rumanians, while the 18th Hussar Regt. of the 3rd Cav. Div. at Chertisiora secured the front towards the E., whence there had been since Sept. 27 decreasing indications of an advance by the Rumanian II. Army.

As the bringing up of reinforcements through the Roter Turm Pass from the S. failed, the Rumanian Command were compelled to set the II. Army on the march towards Hermannstadt to relieve the seriously threatened group under Gen. Popovici. The II. Rumanian Army executed their movements slowly and with difficulty, and since an advance on the shortest line in the Alt valley from the N. over Fogaras from the Agnetshelm-Henddorf district might easily have been threatened on the flank, the Rumanian Army Command thought themselves first compelled to secure freedom of movement N. of the Alt river. The sections of the 71st Inf. Div. in the forward positions were therefore first pressed back, and then the 6th Cav. Bde. of the 1st Cav. Div. standing N. of Klein Schenk were thrown back westwards. Meanwhile, the Austro-Hungarian I. Army Command had sent from Schässburg to Heandorf the greater part of the 89th Inf. Div., one infantry regt. and one light field-howitz detachment going off by rail as army reserve to Salzburg (N. of Hermannstadt). Pushing between the 71st Inf. Div. and the Cav. Corps, they made on Sept. 28 a successful attack in a southerly direction, and so put the brake on the advance of the Rumanian troops N. of the Alt. The I. Army of Gen. Arz had to withdraw steadily westwards under the superior weight of the IV. Rumanian Army, and as the seriously weakened 19th Landsturm Mountain Bde. especially had great difficulty in withstanding the continued Rumanian attacks in the direction of Schässburg, the I. Army Command considered it necessary to withdraw the 71st Inf. Div. to the Little Kukillo (Kokel). Gen. Falkenhayn urgently dissuaded them from this move, as it would expose his eastern flank to an unbearable threat. He also expressed his doubt as to the ability of the I. Army, when once it had been pressed back behind the line of the Makos and the Little Kukillo, to maintain that position permanently with its present forces. Thereupon the withdrawal of the southern wing of the I. Army was delayed.

On the afternoon of Sept. 28 the Rumanians again attacked the 1st Cav. Div. N. of the Alt, and pressed them back to the heights E. of the Haarbach; the reserve, not required at Hermannstadt, was hastily sent with heavy motor wagons through the Haarbach valley to the aid of the heavily engaged Schmettow Cavalry Corps. Meanwhile, however, the fate of the Rumanians in the Roter Turm Pass was sealed, the attacking troops of the XXXIX. Res. Corps ceasing to meet with serious resistance in the early morning of Sept. 29. Those who were not able to escape through the forests over the mountains fell a sacrifice to the inexorable onslaught. The bulk of the Rumanian I. Army was destroyed. Three thousand prisoners—a relatively small number—were taken, but the whole of the artillery and the whole train fell into the hands of the victors.

It was now necessary rapidly to take new decisions for fighting the II. Rumanian Army, the threat of whose approach was im-

minent. In accordance with the instructions received, the IX. Army was to gather all its strength, and to deliver an enveloping attack from the S. against the southern wing of Rumanian main forces pushed forward W. of Fogaras. Falkenhayn intended to relieve the Alpine Corps for this purpose by the 51st Honved Inf. Div., to assemble the 76th and 187th Inf. Divs. on the heights of Scorei on both sides of the Alt, and then to push forward in an easterly direction, an enveloping attacking movement in the Fogaras mountains being assigned to the Alpine Corps. But the rapid and violent push of the Rumanians in the space between the Haarbach and the Alt on Sept. 29 entailed changes in the plan of operations. The relief of the Alpine Corps had to be given up, as involving too much time; instead, the 51st Honved Inf. Div. and the 76th Res. Div. were to reach as rapidly as possible the Alt valley S. and N. of Avrig and the 187th Inf. Div. Cornatiulu in the Haarbach valley. The seriously weakened Cavalry Corps was to attach itself for the forward movement to the N. wing of the 187th Inf. Div. Of the I. Army, the 89th Inf. Div. and the strongest possible sections of the 71st Inf. Div., under the command of Lt.-Gen. von Morgen, were asked to attack in the direction of Bekokten. The beginning of the attack was proposed for Oct. 1.

To the surprise of their enemy the Rumanians did not continue the attack N. of the Alt on Sept. 30, but withdrew a little from the Cavalry Corps. With this object they attacked S. of the Alt and drove back the 18th Hussar Regt. westwards of Chertisiora. The weariness of the troops and their almost impassable state of the roads, owing to the rain which had set in, delayed the forward movements, and it was agreed to begin the attack on Oct. 2. The Rumanians did not take advantage of the loss of time this entailed on the German-Austrian side, but entrenched themselves in the positions they had reached.

The unification of the command in Transylvania was established by placing the Austro-Hungarian I. Army from Oct. 2 under the operative control of Falkenhayn.

On Oct. 2 began the advance of the XXXIX. Res. Corps, the Schmettow Cav. Corps and the I. Res. Corps. South of the Alt the Rumanians offered no resistance, but retreated according to plan before the German advanced troops. North of the Alt, after strong forces had been brought up by way of Gross Schenk in a westerly direction, the advance also began. The 89th Inf. Div. attacked in the direction of Bekokten, and at first obtained a great success, but was thrown back to its point of departure by a Rumanian counter-attack. The 71st Inf. Div. had not been able to join in this attack because its artillery was not yet in position on account of the softness of the chalky roads after rain. Lt.-Gen. von Morgen thought the situation of these two divs. so endangered that he intended to withdraw them as far as the sector Heandorf-Jakobsdorf. On Oct. 3, however, this idea was abandoned, as the enemy themselves had withdrawn eastwards. Owing to this movement touch with the Rumanians became extremely loose, which made it exceedingly difficult for the Austro-German Command to discover betimes the measures taken by them.

On their side the Rumanians had obviously abandoned as early as Oct. 2 the idea of continuing the offensive. Impressed by the annihilating defeat at Hermannstadt and recognizing the impossibility of attacking in a tactically unfavourable situation the IX. Army, rapidly advanced eastwards, they had decided to withdraw betimes in order to defend the frontier passes. In order to secure the time necessary for the threading of the marching columns into the passes of the Geisterwald, the Harigita and the Gungyay mountains, the Rumanians undertook a series of forward pushes: on Oct. 1 S. of the Alt, and on Oct. 2 against the 89th Inf. Div. Against the I. Army these attacks continued until Oct. 5, and during them the Rumanians, especially on Oct. 3, obtained a fresh success against the 19th Landsturm Mountain Bde. and the Landsturm Hussars.

Though the IX. Army Command could not yet fully discern the intentions of the enemy, the puzzling behaviour of their opponents seemed no reason for delay, and the advance was therefore pushed forward with the utmost speed. The 3 divs. of

Lt.-Gen. Staabs were taken into the space S. of the Alt, the I. Res. Corps was to reach the passages over the Alt at Comana and Hëviz, while the Cav. Corps was to reach the N. wing of the IX. Army.

*The Battle in the Geisterwald.*—The Rumanians retired on the whole E. front, without being brought into action by the pursuing troops of the Austro-Hungarian I. Army and the German IX. Army. It was only after dusk on Oct. 4 that the XXXIX. Res. Corps was able to bring the Rumanians to a stand on the western slope of the Geisterwald in a prepared position behind the Sinca brook. The corps were ordered to attack early on Oct. 5, while the 76th Res. Div. was to advance along the high road to Volkány, the 51st Honved Inf. Div. to Vledény, and the 187th Inf. Div. over the mountains, enveloping the enemy on the N., in the direction of Krizba. The 8th Mountain Bde., just arrived at Hermannstadt, was ordered to follow the XXXIX. Res. Corps forthwith in the Alt valley. It was intended to allow them to advance W. of the Königstein towards the road Kronstadt—Câmpolung.

Morning mists and the time taken by the enveloping movement of the 187th Inf. Div. in reddish mountain country delayed the beginning of the attack on Oct. 5. In order to lose no time Lt.-Gen. von Staabs ordered the 76th Res. Div. and the 51st Honved Inf. Div. to attack alone in the forenoon; they soon captured the Rumanian positions, the Rumanian 4th and 3rd Inf. Divs. suffering heavy and bloody losses in their violent counter-attacks. But when the enveloping movement of the 187th Inf. Div. became effective the Rumanians began their retreat into the Kronstadt basin with the utmost haste, at the cost of a great part of their artillery. Close upon them followed the victorious divs. of Gen. von Staabs. Meanwhile the advance guard of the 89th Inf. Div. had reached Comana on Oct. 5, after, by quick action, succeeding in putting out the fire which the Rumanians had set to the bridge. After a stiff pursuing action the 71st Inf. Div. took Reps, but, N. of Hëviz, met with strong resistance from the enemy which was only broken down on the morning of the 6th. The 89th Inf. Div. which had been brought up here, was marched through Hëviz in front of the 71st and directed over the Bogat saddle towards Földvár. The Schmettow Cav. Corps had assigned to it the task of throwing back the 2nd Rumanian Cav. Div. over the line Mehburg—Pálos. But the Rumanian Horse escaped attack by a hasty retreat towards the N.E., and established temporarily contact in the Upper Alt valley between the two Rumanian armies, which were diverging more and more.

*The Battle of Kronstadt (Deaseu).*—On Oct. 6 the divs. of the XXXIX. and I. Res. Corps in their marching lines sought to reach the western outlets of the defiles of the Burgenland. The attack on the 3rd, 4th and 6th Divs. of the Rumanian II. Army, crowded together around Kronstadt and entangled with one another during the retreat, was fixed for Oct. 7. The 76th Res. Div. was to reach the Törzburg Pass by way of Tohanul-Törzburg. Kronstadt was the goal fixed for the 51st Honved Inf. Div., advancing by Feketchalom, while the 187th Inf. Div., attacking to the N. of it, was to wheel inwards, its flank protected from the N.E. in order to envelop Kronstadt and the entrance to the pass S.E. of it. On Oct. 7 the 89th Inf. Div. was to reach Földvár and the 71st Inf. Div. Miklovár. Of the Cavalry Corps the 3rd German Cav. Div. was to push forward through Barót towards Mikoujafu, to hinder Rumanian movements of troops in the Alt valley; the 1st Cav. Div., pressing forward towards Szt. Egyházas-Olahalu, was to bar the retreat of the rear sections of the Rumanian troops still on the Székely-Üvöshely—Csikaredra road.

On the early morning of Oct. 7 the vanguard of the 76th Res. Div. emerging from the mountains at Tohanula was caught by the Rumanian artillery fire, and could penetrate no farther. The main body had therefore to make a wide détour by Zernesti against the Rumanian left flank, and a pause was made for the arrival of the heavy artillery. Thus this div. could make no further progress on the 7th. But the 51st Honved Inf. Div. and the 187th Inf. Div. rapidly approached Kronstadt, meeting,

however, with violent resistance from the Rumanians on the N. and W. sides of the town, so that it was not until evening that the vanguard of the 187th succeeded in penetrating into the northern part of the town, where an obstinate street fight raged all night. Next morning the 51st Honved Inf. Div. also went their way in and stormed the heights S. of the town.

In consequence of the enveloping movement through Zernesti and the threat exercised by the 8th Mountain Bde. approaching W. of the Königstein it became possible for the 76th Res. Div. on Oct. 8 to seize Törzburg and the heights on either side of it together with the entrance to the Törzburg Pass. The advance against the pass was continued, and, in addition, a detachment was pushed forward through the Klein Weidenbach valley toward the Tömös Pass in order to bar the Rumanian retreat here. Although this div. failed to reach the road, its appearance threatening proximity caused a panic-like flight of the troops and transport hastening southwards.

Meanwhile the Rumanians tried to hold up the German advance N. of Kronstadt, and, with reinforcements hurried up partly by rail from Sepsis-Bzt. György, delivered violent counter-attacks against the E. wing of the 187th Inf. Div., standing at Szentpéter, which was hard pressed, till the attack of the 89th Inf. Div. from the N. struck the Rumanians unawares.

Early on Oct. 9 the victory of the IX. Army was complete. The beaten troops of the 3rd, 4th and 6th Rumanian Div. retreated hurriedly through the passes, so that, supported by the 10th, 21st and 22nd Inf. Divs. brought up for the purpose they might undertake the defence of their country against the pursuing German and Austro-Hungarian divs. in fortified positions on the frontier prepared during peace.

Gen. von Falkenhayn in his pursuit tried to cross the mountains simultaneously with the Rumanians, and by a free distribution of his army, the I. Res. Corps with the 76th Res. Div. and the 8th Mountain Bde. attacked over the Tárab Pass in the direction of Câmpolung. Through the encircling movement of the 8th Mountain Bde. the pass was soon successfully opened, and the 22nd Inf. Div. which had arrived to support the seriously exhausted Rumanian 4th Inf. Div. was repulsed. But the attack of the I. Res. Corps was held up by the strongly fortified positions N. of Câmpolung.

The XXXIX. Res. Corps had orders to push forward through the Tömös Pass with the 51st Honved Inf. Div., and through the Altschanz Pass with the 187th Inf. Div. towards the In-Sinai-Isorle. The 51st Div. did indeed succeed in storming the summit of the pass, but could not penetrate the 21st and 22nd Rumanian Inf. Divs. in their strongly constructed positions. The 187th Div. had a similar experience against the Rumanian 3rd Inf. Division.

The 89th Inf. Div. had to attack through the Tatarhavas and Bodza passes. After reaching the basin lying S. of the frontier, it was held up by the main body of the Rumanian 6th Inf. Div. and by separate regts. of the 3rd, 15th and 22nd Inf. Divisions.

As the German Supreme Command urgently demanded that the strongest possible infantry and cavalry forces should be directed towards Ocna, to control the communications from there northwards by rail, road and telegraph, the 71st Inf. Div. was put under the command of Gen. Count Schmettow, commanding the Cav. Corps, who led the div. in forced marches to the Oltos Pass. On the summit of the pass the div. overran a position held by the Rumanian 2nd Cav. Div. and forced their way over the frontier. Recognizing their peril the Rumanians rapidly pushed up the 38th Inf. Bde. and sections of the 7th, 8th and the newly formed 15th Inf. Divs., and after long engagements with many vicissitudes prevented the 71st Inf. Div. from reaching its goal.

The 3rd Cav. Div. assembled first in the basin of Kécsivárbely, where the 1st Cav. Div., which had pursued the Rumanian 7th Inf. Div. up to the Uz Pass, had also been brought up. As the employment of cavalry on the route by way of Ocna into Moldavia had become impossible, the 1st Cav. Div. established communication in the forest-clad mountains, with their last of roads, between the 89th and the 71st Inf. Divs. The three regts.

of the 3rd Cav. Div. were later on stationed between the Törzburg and the Tömös passes as the Transylvania Cavalry Brigade.

At the Roter Turm Pass the Rumanians—the remainder of the 12th and 23rd Inf. Divs. and the 2nd mixed Brigade of the 18th Div.—had discontinued their attacks against the Alpine Corps, reinforced by the 10th Mountain Bde. At Petrosény the 11th Rumanian Inf. Div. had again been pressed back to the frontier, whereupon the 2nd Mountain Bde. was shifted to the Roter Turm Pass. This was subsequently merged with the 10th Mountain Bde. in the 73rd Inf. Division.

In the Austro-Hungarian army the VI. Corps, with the 30th Honved Inf. Div., reached the frontier in the Uz valley and with the 61st Inf. Div. and the 1st Landsturm Hussar Bde., in the Trotus valley advanced far over the frontier and, after fighting with varying success against the Rumanian 7th Inf. Div., occupied positions on the height of Sulta. On the N. wing the XXI. Corps with the 72nd Inf. Div. reached the Békás Pass, and with the 37th Honved Inf. Div. the Tölgyes Pass. Thus Transylvania, six weeks after the invasion of the Rumanians, was again freed from the invader.

*Plans for the Continuation of Operations.*—New plans had now to be agreed upon, in order to beat the Rumanians in their own country. Naturally the centre of gravity of the operations against Rumania lay in the first instance in Falkenhayn's IX. Army. His attempt to push forward on the shortest line to Bucharest with the troops he had in hand in the pursuit over the passes S. of Kronstadt had not succeeded. The Rumanians now defended themselves much more obstinately, and the German and Austro-Hungarian troops, wearied with their rapid operations, and with their war establishments weakened, had suffered temporarily in buoyancy from this victorious career. Events moved slowly also on the Roter Turm Pass, from which, after crossing the mountains, the main push directed towards Bucharest ought to have been supported by an advance of the reinforced Alpine Corps through Pitești. The pursuit on all the many passes radiating from the Kronstadt basin had dissipated strength, and made the assembly of a strong main force impossible. New forces had to be brought up. These rolled up in Transylvania in the middle of Oct.—the 8th Bavarian Res. Div., the 11th and 12th Bavarian Inf. Divs. and the 6th German Cav. Div.; towards the end of Oct. two further German inf. divs. (the 41st and 109th) and the 7th Cav. Div. were to follow. Moreover, the Austro-Hungarian Higher Command intended to transfer the Austro-Hungarian 3rd and 10th Cav. Divs. to Transylvania, but these would first have to be equipped and organized for employment in the intended offensive.

The 8th Bavarian Res. Div. was sent to the Transylvanian E. front to reinforce the I. Army. The 12th Bavarian Inf. Div. was placed by Falkenhayn under the I. Res. Corps on the Törzburg Pass, the 11th Bavarian Inf. Div. was to attack over the Szurduk Pass with the 144th Inf. Bde., and the group of Lt.-Gen. von Krafft at the Roter Turm Pass was strengthened by 2 Bavarian inf. regts. and 2 German Landsturm regts. At the Tömös, Törzburg, Roter Turm and Szurduk passes the attacks were to be continued, and wherever a gap was first effected Falkenhayn intended to bring up the mass of cav. and the two later arriving inf. divs. to open up the remaining passes southward and in conjunction with Field-Marshal Mackensen's troops, to push forward towards Bucharest.

Both the Supreme Army Commands agreed to this plan. But the Higher Command at Teschen maintained in this connexion that it was desirable for the main pressure to be directed on the line Kronstadt-Bucharest. There the strongest opposing Rumanian and Russian opposing forces were to be expected; moreover, here they had to reckon with a threat of a Russian relieving offensive, urgently asked for by the Rumanians, coming from Moldavia in the general direction of Căk-Szereda. Falkenhayn therefore rather favoured a push through the Szurduk Pass, where, owing to the smaller width of the mountain chain, the Wallachian Plain would be most quickly reached.

On the E. front, meanwhile, the headquarters of the Army Front-Commander, Archduke Charles Francis Joseph, in the

arrangement of the commands, was moved from East Galatz to Grosswardein, as from Oct. 13, and the German IX. and Austro-Hungarian I., VII. and III. Armies were placed under him.

*The Conquest of the Dobruja and of Wallachia.*—After the battle of Kronstadt the Rumanians were entirely reduced to the defensive. On the Transylvanian front they limited their activities to attempts to win back the lost frontier heights commanding important roads of invasion. The Rumanian Army Command also tried to induce the Russians to relieve the Rumanian troops in the Dobruja and on the Transylvanian E. front in order thus to set free forces for the defence of Wallachia.

On the Danube front the Rumanians on Oct. 1 had crossed the river at Rahova (S. of Bucharest) with a div., and had temporarily gained a firm footing. German and Bulgarian troops, rapidly assembled, compelled the Rumanians to return to the N. bank, the latter suffering severe losses, as the Austro-Hungarian Danube monitors had shot to pieces the Rumanian pontoon bridge. Rumanian forward pushes against the Bulgarian III. Army brought no success. On Oct. 19 an attack by Gen. Toshev's Army (Bulgarian 1st, 4th, 6th Divs., and sections of the 12th Inf. Div., 1st Cav. Div., Turkish VI. Corps, with the 15th and 25th Inf. Divs., German 27th Inf. Div.), broke through the Russo-Rumanian front on their E. wing, and drove the opposing army far over the Cernavoda-Constantia railway, Rumania thereby losing her only rail connexion with the sea.

While the bulk of the Bulgarian III. Army followed only as far as the line Lake Taszul-Bazantia—heights of Kvačnik-Danube S. of Topal, and settled themselves for the defence on this shortest line between the Danube and the sea, the reinforced cav. div. pursued the retreating Rumanians and Russians as far as the line Sarıur-Sarıghol-Dövizaci. Gradually the Russians again slowly pushed forward southward against the new position of the Bulgarian III. Army. The Rumanian troops were withdrawn in Nov. from the Dobruja into Wallachia. Of the Russians there were in the Dobruja the VI. Cav. Corps, the XLVII. and IV. Siberian Corps, with 6 inf. divs. and 1 cav. div. in all, which were placed under the command of the newly-formed Russian Danube Army (Gen. Sakharov).

In the new defensive position of the Bulgarian III. Army, which was by this time under the command of Gen. Neresova, there remained the 2d and the combined 6th Inf. Divs., then the 1st Cav. Div. The Turkish VI. Corps stood for the time being at Medzidie in reserve. The other troops in the Dobruja and northern Bulgaria, together with the expected Turkish 16th Div., were collected in the district around Sistova, and were placed in readiness for crossing the Danube as the new Danube Army under the command of Gen. Kosch.

On the Transylvanian S. front the obstinate struggle for the passes was continued. The I. Res. Corps succeeded in reaching a point just N. of Câmpolung after the arrival of the 12th Bavarian Inf. Div. and with the assistance of the enveloping movement in the mountains of the 8th Mountain Bde. on the W. wing. At that point irruption into the basin of Câmpolung was barred by a new strongly constructed position in which the newly brought-up Rumanian 12th Inf. Div., in addition to the 22nd Inf. Div., offered the most obstinate resistance.

At the Roter Turm Pass Lt.-Gen. von Krafft intended to force an exit from the mountains by enveloping on two sides, with the 2nd Mountain Bde. eastwards with the 10th Mountain Bde. westwards, and the Alpine Corps in the centre. The attack began on Oct. 16. After easy initial successes the weather broke on Oct. 18, and this circumstance, together with hastily executed Rumanian counter-attacks, prevented complete success.

South of Petrosény the group of Lt.-Gen. Kneisel, with the 11th Bavarian Inf. Div., the 144th Inf. Bde., and the 6th Cav. Div., began the attack in numerous columns through the Szurduk and Vulkan passes and over the heights to the west. In spite of the fall of snow the advance began on Oct. 23.

News had been received that, under pressure of the preceding attack by Krafft's group and the I. Res. Corps, the Rumanians had deflected against these reinforcements which had been sent up, and that it would therefore be easier to break through. At first,

Indeed, complete success attended the attacks of the Kneusel group. The troops, forcing back the Rumanian 11th Inf. Div., had worked their way to the foot of the mountains N. of Târgu Jiu, and were to fight their way out to the plain on Oct. 27. At this point, however, a counter-attack by the hurriedly summoned Rumanian 21st and 22nd Inf. Bdes., and a regt. of the 1st and 3rd Inf. Divs., struck the W. wing. After losing many in prisoners and guns the German detachments had again to withdraw to the frontier heights, whither the Rumanians pursued them only with skirmishing detachments. In spite of the defeat he had suffered Falkenbayn held fast to the idea of a break-through by way of Târgu Jiu, and directed the newly arriving troops (41st and 109th Inf. Divs. and 7th Cav. Div.) to Petroșeny. After the experience just gained the most thorough preparations were to be made for this operation, which was to begin on Nov. 11, Lt.-Gen. Kühne of the LIV. Res. Corps being chosen for the command of this strengthened group.

Urged by the Rumanian Army Command, the Russians relieved the Rumanian troops facing the Austro-Hungarian I. Army, beginning from the N., and pushed the southern boundary of their IX. Army in the middle of Nov. to a point just N. of the Gyimes Pass. Simultaneously with the III. Cav. Corps and the XXXVI. Corps, they attacked in this new sector the Austro-Hungarian XXI. Corps on Nov. 6. In expectation of this Russian push forward the army front command had placed in reserve the Brudermann Cav. Corps (3rd and 10th Cav. Div.) in the district Olah-Toplica-Gyergyó-Szt. Miklós, the 10th Bavarian Inf. Div. brought southwards from the VII. Army in the district around Csik-Szereda, and the bulk of the 8th Bavarian Res. Div. at Kézvissaszerhely. The Russian forward movement obtained small successes on both sides of the Tölgyes and Békás Pass. After the bringing up of the 10th Bavarian Inf. Div. and the 3rd Cav. Div. the situation was once more restored.

In the Ojtoz Pass also, where the 71st Inf. Div. and the 1st Cav. Div. were once more placed under the I. Army as from Oct. 29, and in the Trotus valley, the Rumanians, partly mixed with Russian units, attacked on Nov. 5 without obtaining noteworthy successes.

*The Break-through at Târgu Jiu.*—According to plan, the attack of the group of Lt.-Gen. Kühne began on Nov. 11 S. of the Szurdok and Vulkan passes. They were to force their way into the Wallachian plain before the approach of winter made mountain operations impossible. Simultaneous attacks on all the other passes of the Transylvanian S. front and at Orsova were to distract the attention of the Rumanians and divert their reinforcements from the principal theatre of attack, an intention which was successfully accomplished.

Protected by the 41st Inf. Div. on the W., with the 109th and 301st Inf. Divs. E. of the river Schyl, on the W. flank by sections of the 6th Cav. Div. and the 9th Regt. of the Hungarian Landsturm, the troops fought their way out of the mountains in an obstinate struggle lasting from Nov. 11 to 14, and on Nov. 15 reached Târgu Jiu. The Rumanian 11th Inf. Div., seriously weakened, retired to the heights S. of the town, where it again gave battle with rapidly brought up new forces of about the strength of two divisions. In the Kühne group the Schmettow Cav. Corps (6th and 7th Cav. Divs.) was brought along the road over the pass and placed on the W. wing for the envelopment of the enemy; the 11th Bavarian Inf. Div., hitherto in reserve, was placed on the front E. of Târgu Jiu, while the 301st Inf. Div. acted as covering troops on the east.

On Nov. 16 the Kühne group attacked once more. On Nov. 17 the Rumanians, in spite of the most courageous defence, were decisively beaten. The road into Wallachia lay open. The pursuit was undertaken without delay. With the right wing (6th Cav. Div. and behind that the 41st) in the Jiu valley through Craiova, the centre (109th and 11th Bav. Inf. Divs.) towards Slatina, and the left wing (301st Inf. Div.) in the direction of Dragassani, the group swerved eastwards and made rapidly for the Alt. On Nov. 21, Craiova, the capital of Wallachia, was reached. The rapidly attacking vanguard of the 6th Cav. Div. succeeded on the 23rd in seizing the bridge E. of Caracal, which

had remained undamaged, over which the main body of this division on Nov. 24 and the 7th Cav. Div. on the 29th crossed the Alt, in order to push on against the Vede sector.

The Rumanians, repulsed from Târgu Jiu (11th and 12th Inf. Divs. and parts of other divs.) placed themselves after the destruction of the bridges on the E. bank of the Alt between Slatina and Dragassani, in order to bar at this point an advance by Lt.-Gen. Kühne's troops. Farther N. too, opposite the group of Lt.-Gen. von Krafft, the Rumanians had evacuated the W. bank of the Alt, so that the German troops were able to occupy Rimnik Vlcea on Nov. 25. The attempts of the 41st and 11th Rav. Inf. Divs. on Nov. 25 and 26 to cross the Alt at Slatina failed, in spite of the support of some squadrons of the 7th Cav. Div., which had already come into action from a S.E. direction. The 109th Inf. Div. was now sent in support of the Cav. Corps by way of Caracal, and was soon followed by the 11th Rav. Inf. Div. and the 15th Inf. Division.

In consequence of the rapid break-through at Târgu Jiu the retreat of the Rumanian Orsova group, 3 regts. of the 1st Inf. Div. with artillery, was cut off. Held in front by violent attacks on the part of the group of Col. Szivó, they were shut in on the rear by detachments of the Kühne group. In a series of engagements in which at one time they threatened the rear communications of the Kühne group, this Rumanian group went down along the Danube, until, completely surrounded at the mouth of the Alt, they laid down their arms before their pursuers on Dec. 6. Ten thousand men and 40 guns fell into the hands of the much weaker Szivó group.

In front of the group of Lt.-Gen. von Krafft, reinforced by the newly arrived 216th Inf. Div., the Rumanians also could not hold their own on the E. bank of the Alt in spite of the participation of the 7th and parts of the 8th Inf. Divs.; they retreated as far as Curtea d'Arges and behind the Topolog sector, where they offered a temporary resistance.

The I. and XXXIX. Res. Corps (under which latter the 89th Inf. Div. in the Bodza Pass had been placed) maintained undiminished pressure on the Rumanian groups opposed to them. With the aim of building up a further reserve of the army front, the 187th Inf. Div. was relieved by the approaching Austro-Hungarian 24th Inf. Div., and placed in readiness in the Hâromszék. The Ojtoz group now under the command of Gen. von Gerok, of the XXIV. Res. Corps, was on Nov. 11 again placed under the IX. Army Command. On the E. front the Russians continued the relief of the Rumanians as far as the road over the Ojtoz Pass.

*Crossing of the Danube Army at Sistova.*—On the side of the Central Powers the Army Command now thought the moment had arrived for the Danube Army in position at Sistova to cross the Danube and push forward towards Bucharest, in order, in conjunction with the approaching IX. Army, to effect the complete conquest of Wallachia. The Danube Army consisted of the 217th German Inf. Div., the 1st and 12th Bulgarian Inf. Divs., the combined Cav. Div. of Maj.-Gen. Goltz, German and Bulgarian Landsturm troops, German and Austro-Hungarian heavy artillery, the 26th Turkish Inf. Div. and Austro-Hungarian pioneer formations. At 4 A.M. on Nov. 23, favoured by thick mist, and supported by the Austro-Hungarian Danube monitors and the German motor-boat flotilla, the transport across the river of the 217th Inf. Div., unnoticed by the enemy, was successfully accomplished without delays. Zimnica was occupied. Then the 1st Bulgarian Inf. Div. and the Landsturm formations crossed; the resistance of Rumanian detachments brought up was rapidly conquered.

On Nov. 24 the bridge-head was widened, and the construction of a pontoon bridge by the Austro-Hungarian pioneer group of Maj.-Gen. Gaugl was begun, and finished in the afternoon of Nov. 25 at 6 o'clock. The remaining troops were now brought over the bridge in unbroken sequence, and the advance was begun; on the left wing the cav. div. towards Alcaandri, on its right the 217th Inf. Div., then the 12th and 1st Bulgarian Inf. Divs. The Turkish 26th Inf. Div. followed as Army Reserve behind the left wing. Rapidly advancing, and quickly

battling the resistance of the Rumanian 18th Inf. Div. and the 1st and 2nd Cav. Divs. sent against them, the heads of the columns had already on Dec. 1 reached the Argeşu, S.W. of Bucharest. But in this hurried forward movement the Danube Army, after establishing only slight contact by means of cavalry at Roşi de Vede, again lost touch with the main body of the IX. Army, held up on the Alt sector; their left flank lay open.

**Battle of the Argeşu.**—The Rumanians recognized the opportunity offered them of falling on the rashly advanced Danube Army. They endeavoured, with their I. Army, to keep the Kühne and Krafft groups as far to the W. as possible, and also made violent frontal attacks across the Argeşu on the isolated Danube Army, and on Dec. 2 from the N.W., completely encircling the left wing of the Danube Army, with the Rumanian 1st Cav. Div., then parts of the 2nd, 5th, 9th and 19th Inf. Divs. The Danube Army was thus placed in an extremely critical position. Rapidly brought-up Landsturm battalions, a few pioneer companies and the 26th Turkish Inf. Div., advancing in the second line, compelled a pause in the Rumanian enveloping movements. This Rumanian manoeuvre, which only failed of success because it was not executed with sufficient energy, was coincident with violent pushes carried out by the Russians on the Carpathian front, from the Tartar Pass southwards to the Ojtoz Pass and on the Dobruja front; and also with attacks by Gen. Sarrail's Army on the Salonika front, by which it was hoped to relieve the hard-pressed Rumanian Army and to snatch from the Central Powers the advantage developing in this area. Yet all efforts were in vain.

The right wing of the IX. Army, which had been placed from Nov. 30 under the army group command of Field-Marshal von Mackensen, was brought up with the utmost haste. The 10th Inf. Div., advancing northward on Nov. 27 and 28 on the E. bank of the Alt, had at last succeeded in compelling the Rumanian I. Army to abandon the Alt sector. The 41st and 30rst Inf. Divs. could then cross the river at Slatina. The pursuit towards the E. was conducted in the following groups: along the projected Craiova-Bucharest railway the 11th Bavarian Inf. Div.; behind that the 15th Inf. Div.; N. of the Bavarians, the 10th, 41st and 30rst Inf. Divs. The Schmettow Cav. Corps had ridden in advance of the right wing. Thus the IX. Army approached the seriously threatened left wing of the Danube Army. On Dec. 2 parts of the Cav. Corps, and on Dec. 3 the 11th Bavarian and 10th Inf. Divs., swerving southwards, were able to participate in the battle. The Rumanians, now themselves enveloped, turned back with heavy losses to Bucharest. For the Danube Army the crisis was over.

While on Dec. 2 and 3 the main body of the Schmettow Cav. Corps and the 10th Inf. Div. covered the road to Bucharest, Lt.-Gen. von Krafft at the same time, with the 216th, 73rd and 30rst Inf. Divs., struck the remnant of the Rumanian I. Army on the middle course of the Argeşu, and pushed forward with the Alpine Corps and the 2nd Mountain Bde. towards Tirgovişte, which, after the capture of Câmpolung, the I. Res. Corps was also approaching.

Attacks by the just arriving Russian 40th Inf. Div. and the 8th Cav. Div. on Dec. 4 and 5 against the Bulgarians on the S. wing of the Danube Army gave no results. The violent attacks delivered by the Russians against the Austro-Hungarian Army and against the Bulgar-Turkish Dobruja front in the beginning of Dec. were also continuously repulsed.

**The Capture of Bucharest.**—On the evening of Dec. 5, after successful engagements, the Danube Army stood E. of the Argeşu and S.W. of Bucharest, and the IX. Army in close touch N. of the town as far as the Prahova valley. Since it was doubtful whether Bucharest would be defended as a fortress, heavy artillery and all the means of attack were placed ready to hasten its capture. In the night of Dec. 5-6 cavalry of the Schmettow Corps rode up towards the N.W. front, and found the works blown up and unguarded. The Rumanians evacuated their capital almost without fighting. On the night of Dec. 6 the troops of the Danube Army and parts of the S. wing of the IX. Army entered Bucharest, while on the same day

Falkenhayn's N. wing captured Ploesti, and with it the important petroleum area, where English hands had previously rendered the boring apparatus useless for a considerable length of time. Two days later, as the result of rapid enveloping movements carried out by Lt.-Gen. Morgen's group, the 4th Rumanian Div., left stranded in the mountains, were surrounded in the district N. of Ploesti, and were taken prisoners. The road to the S. now also lay open to Lt.-Gen. Stănescu's group. The 51st Honved Inf. Div. was able to occupy Sîlnic.

**Pursuit to the Danube-Sereth Line.**—Field-Marshal von Mackensen now received the order to push forward with his army group (III. Bulgarian Army, Danube Army and IX. German Army) to the shortest line of communication between the sea and the Carpathian front, that is the Danube mouth-Gabitz-Sereth to Ajudamiu-Trotus river. The IX. Army was to advance between the mountain river and the projected railway line Bucharest-Usceni-Forcivechi-Teuchiu; the Danube Army between this line and the Danube; the Bulgarian III. Army to advance in the Dobruja.

On Dec. 12 the IX. Army threw the Rumanian I. and II. Armies, reinforced by the Russian IV. Inf. and VI. Cav. Corps, out of a fortified position on both sides of Mizil, and on Dec. 15 took Buzău. There the 8th Inf. Div., which had advanced south-eastward from the Bodza Pass into the Buzău valley, joined Falkenhayn's army. The Danube Army on Dec. 14 won the way through the Jalomitsa sector against the Russian VIII. Inf. Corps and III. Cav. Corps. On Dec. 17 the two armies faced a Russo-Rumanian position running along the line from the lower course of the Calmatuciu by Forcivechi along the heights W. of Rimnicu-Sarat.

Meanwhile the Bulgarian III. Army had begun to clear the Dobruja and, meeting with little resistance, had soon reached the Danube estuary; turning towards the eastern bridge-head from Braila at Macin it transferred the Turkish VI. Corps to the Danube Army.

At Christmas the IX. and the Danube Armies broke through the enemy positions, and threw the Russians and Rumanians back northwards. On Jan. 4 1917 the Danube Army captured Braila, and pressed forward as far as the Sereth; on Jan. 8 the IX. Army took Focşani and the country N. of it as far as the Putna. On the S. wing of the army front the Archduke Joseph launched the attack against the Russians in the last days of Dec. the Gerok group with the 218th Inf. Div., the 1st Cav. Div., the 71st Inf. Div. and the 187th Inf. Div. The S. wing fought their way through the extensive wooded mountain district, and effected a junction with the IX. Army. South of the Ojtoz road the attack came upon the Russians who were relieving the Rumanians. The Rumanian 15th Inf. Div. was again thrown into the action. The attack of the Gerok group only succeeded in winning a little more ground here. Fall of snow and sharp frost made further operations impossible.

The actual line won was fairly near the sector it had been intended to reach. On the side of the Central Powers it was decided to go into permanent positions here. There was reason to be satisfied with the success of the campaign. Transylvania was liberated; a country rich in resources, Wallachia, had been conquered; the Rumanian Army had been thoroughly beaten, and had for the most part ceased to be a factor in the fighting for a long time to come. The Russian Army, instead of giving the hoped-for support, had had in addition to take over another 400 km. of front. The Russians, too, were glad after a year too full of fighting to be able to rest. Besides the IX. Army (16th Inf. Div. and 2nd Cav. Div.), extending from the Bukovina to the Casinu valley south-eastward of Ocna, the Russian new IV. Army stood here from Racoşa on the Susita to Suraia E. of Focşani (6th Inf. Div.); from there eastwards to the Black Sea the VI. Army (9½ inf. divs. and 3 cav. divs.). Of the Rumanians only from 5 to 6 divs., reinforced by Russian troops, remained on the front as the Rumanian II. Army, between the Russian IX. and IV. Armies. The remnant of the Rumanian Army, saved with difficulty, was transferred to the district between Jassy and Târgu Frumos to recuperate. A French mil-



itary mission undertook to reorganize the army, and to give it a thorough education based on the principles of the conduct of modern warfare. This task it had finished by the summer.

*The Battles N. of Focșani in the Summer of 1917.*—In the spring of 1917 events took place of the most far-reaching significance for the conduct of the war in the East: the deposition of the Tsar, the outbreak of the revolution in Russia and the beginning of the collapse of the Russian army. As on all parts of the eastern front, so in Rumania, the Russian Infantry had no more desire for fighting; the Russian artillery, left to carry on alone, were threatened by the infantry; indeed it came to regular battles between the two arms. It was only with difficulty that the numerous officers of the Western Powers distributed among the higher commands could prevent the collapse of the eastern front. The fighting value of the Russians did indeed improve at the time of the Kerensky offensive of June 1917, but the improvement was not a lasting one. The Rumanian troops remained untouched by all these happenings. Indeed it seemed as if Rumania's fighting strength increased in proportion as her ally became less reliable.

In the second half of July the reorganized Rumanian I. Army was placed between the Russian IV. and VI. Armies from a point E. of Nemolosa to S. of Tecuciu on the Sereth front.

In connexion with the operations in East Galicia the Central Powers intended to strike a decisive blow against the Russians and Rumanians in Rumania, in order to shake the whole Carpathian front and if possible to gain Moldavia. The operation planned across the Sereth at Nemolosa was to begin in August. The preparations for this were in train when the Rumanians anticipated the attack.

*Rumanian Attack at Soveja.*—On July 25 the Rumanian II. Army, with the IV. and II. Corps, and the Russian VIII. Corps on the N. wing of the Russian IV. Army, broke through the weak front of the 218th Inf. Div. and the 1st Cav. Div. and threw them far beyond Soveja back into the mountains, the wing division of the IX. Army being thereby surrounded on the N. and N.W. by the Russian VIII. Corps. Even though there was little need to fear Rumanian advance against Kézdivásárhely in the rear of the I. Army, on account of the width and impassable nature of the mountains, there was all the more danger that, after the capture of the Mt. Odobeshti (Odobesti), the whole front of the IX. Army, which covered the sphere of the earlier Danube Army and was commanded by Gen. Kösch, might be rolled up from the north. This was obviously the intention of the Rumanians and Russians, but the troops in carrying out the operation did not strike hard enough. Precious time was thereby lost. On account of the want of roads direct support of the 218th Inf. Div. was hardly possible. It was only slowly that one regiment of the 117th Inf. Div., and then half the 37th Honved Inf. Div., which had been set free from the N. wing of the I. Army, could be brought up. The 217th Inf. Div. was supported by single regiments and battalions of 5 different divs. of the IX. Army, and the attack was thus barred.

In the counter-operation planned by the Central Powers it was intended to take up again the original plan of penetrating far into Moldavia. For this purpose the IX. Army was to conduct the main attack from Focsani W. of the Sereth in the direction of Ajudu Nuou, and simultaneously to cover this attack by the construction of a bridge-head on the E. bank of the Sereth in the direction of Tecuciu. A second push was to be delivered by the Gerok group from the Ojtoz valley on Onesi. By this means the Rumanian II. Army, which had advanced into the basin of the Soveja, was to be cut off.

*Engagements North of Focșani and South of Ocna.*—For the attack which was to start from Focsani the following were placed in readiness under the command of Lt.-Gen. von Morgen (I. Res. Corps): the 12th Bavarian Inf. Div., 26th Res. Inf. Div., and the 89th Inf. Div., to be followed in second line by the 216th Inf. Div. As army reserve there stood at Focsani the 212th and 115th Inf. Divs. On Aug. 6 the attack began, and had indeed the desired success on the first day in a N.W.

direction. The attempt to cross to the E. bank of the Sereth, however, failed.

The Russian Corps which were attacked (the VII. and behind that the XXX.) put up a surprisingly obstinate defence. It was only after throwing in the army reserves that the German I. Res. Corps succeeded in overrunning the Susita sector. Moreover, the 5th and 9th Rumanian Divs. of the Rumanian I. Army also came forward to face the attacking Germans, and caused considerable delay, especially at Marasesti (Marashesti), by their violent, deeply echeloned counter-attacks.

On Aug. 20 the VIII. Corps with 3 (partly combined) divs. reinforced the attack of the Gerok group on both sides of the Ojtoz valley. They attacked the Rumanian IV. Corps (6th and 7th Inf. Divs.), and gained ground as far as just S. of Ocna and Groesci. But on account of the obstinate resistance of the Rumanians the objective, Onesi, could not be reached.

Left of the I. Res. Corps the XVIII. Res. Corps, reinforced by the Alpine Corps, once more in action, had meanwhile joined in the attack with their left wing, and after heavy engagements had taken Panciu N. of the Susita. On Aug. 15 the S. wing of the Gerok group (218th Inf. Div. and sections of the 117th Inf. Div., half the 37th Honved Inf. Div. and the 8th Mountain Bde.) and the 217th Inf. Div., standing on the left wing of the XVIII. Res. Corps, also joined the attack and slowly drove the Rumanians out of the basin of the Soveja. A bridge-head on the W. bank of the Sereth threatening the German flank, held by the Rumanian 5th Div., was stormed by the 216th Inf. Div. of the I. Res. Corps on Aug. 14, severe losses being inflicted on the Rumanians. The further attempts of the I. Res. Corps, under which was placed the newly arrived 13th Rifle Div., to advance over the line Marasesti-Panciu, failed through Russian and Rumanian counter-attacks.

In consequence of the events in East Galicia and in the Bukovina, where the Russians were driven back to the old boundary of the Empire, a regrouping of troops and new distribution of the armies in Moldavia was effected. The troops of the Russian IV. Army were withdrawn to the N. to the VII. Corps, and the Russian IV. Army Command took over from the IX. Army Command the sector on the Transylvanian E. front as far as the Slanic valley. The Rumanian I. Army also took over the sector held earlier by the Russian I. Army, so that the two Rumanian armies now stood side by side.

On Aug. 28 the XVIII. Res. Corps, with the 216th Inf. Div. and the Alpine Corps, attacked from the line Panciu-N. edge of the Mt. Odobeshti in a N.W. direction, to gain the upper course of the Susita. After stubborn engagements lasting for many days against the Rumanian II. Corps, Jresci and the heights S. of the Susita were captured, upon which practically the old line, as it stood before the Rumanian attack, was reached. On Sept. 3 attacks from the German side were again suspended.

At the beginning of Sept. the Rumanians with the IV. Corps conducted a series of violent attacks against the advanced positions of the VIII. Corps, especially against the 225th Inf. Div. standing just S. of Ocna, but they were bloodily repulsed.

On the side of the Central Powers, after this unsuccessful enterprise, the troops which could be spared (the Alpine Corps, the 13th Rifle Div., the 117th Inf. Div. and much heavy artillery) were withdrawn for transfer to other theatres of war. The remaining units again went into permanent positions. On the Rumanian side the fruitless attacks ceased. They had suffered heavy losses in killed and wounded, and important loss in prisoners and material. The newly formed Rumanian divs., instructed by the French, had succeeded in defending their country from complete conquest. The battle of Marasesti, as it was called by the Rumanians, is the most famous page of the Rumanian Army in the World War.

*Armistice of Focșani.*—On Dec. 5 the commander-in-chief of the Russian S.W. front, Gen. Shtcherbachev, asked for an armistice. On Dec. 7 the negotiations began at Focșani under the presidency of Lt.-Gen. von Morgen; representatives of all the participating armies took part, and they were concluded on Dec. 10. (R. K.)

**EASTMAN, GEORGE** (1854- ), American inventor and philanthropist, was born at Waterville, N.Y., July 12 1854. He was educated at Rochester and early became interested in photography. In 1880 he began to manufacture dry plates and four years later produced the first practicable roll film. In 1888 he invented the "kodak." In 1900 he gave \$250,000 to the Rochester Mechanics' Institute. He has given laboratories to the university of Rochester and has donated \$500,000 toward that university's endowment. To its school of music he has given \$3,500,000 and to its medical school \$4,000,000 (1920). In 1920 it became known that he had given at various times large sums to the Massachusetts Institute of Technology, amounting to \$11,000,000.

**EBERT, FRIEDRICH** (1871- ), first president of the Reich or German Federated Republic, was born Feb. 4 1871 at Heidelberg, where he attended the national elementary school and then learned the trade of a saddler; after he had become a journeyman he migrated, according to the German custom, from place to place in Germany, seeing the country and learning fresh details of his work until he finally settled at Bremen. There he became interested in the agitation of the Social Democratic party, obtained in 1893 an editorial post on the Socialist *Bremer Volkszeitung* and in 1900 was appointed a trade-union secretary and ultimately elected a member of the Bremen *Bürgerschaft* (comitia of citizens) as representative of the Social Democratic party; in 1905 he was elected to the presiding board of his party and was returned as a deputy to the Reichstag in 1912. In 1913 he was chosen as successor to Bebel to preside over the whole Social Democratic party. During the World War he endeavoured by negotiations with the Dutch and Swedish Social Democrats to prepare the way for united action by all the Socialists in the belligerent countries. He took part in 1917 in the Stockholm conference, which, however, had no practical result. He likewise endeavoured without success to bring about a German understanding with Russia. After the revolution he was one of the six commissaries of the people who formed the first provisional Government, in which he shared the presidency with the Independent Socialist-Haase. His influence among the commissaries became predominant, and he rendered eminent services in conjunction with the Socialist War Minister, Noske, and the Socialist leader, Scheidemann; in the restoration of tranquillity and orderly administration. He was a keen opponent of all varieties of the Spartacist, Communist or Bolshevik movements, and bore a leading part in the suppression of the Spartacist insurrections. He was elected president of the Reich by the National Assembly at Weimar on Nov. 12 1919. (C. K.)

**EBNER-ESCHENBACH, MARIE, FRIEDRAU VON** (1830-1916), Austrian novelist (see 8.843), died in 1916. (See also AUSTRIAN EMPIRE: *Literature*.)

**ECHEGARAY, JOSÉ** (1833-1916), Spanish author and playwright (see 8.870), died at Madrid Sept. 16 1916. Together with Frederic Mistral, he was awarded the Nobel prize in 1904.

**ECONOMIC ENTOMOLOGY** (see 8.896).—During 1910-21 the value of economic entomology as an essential part of applied science had been definitely realized throughout the civilized world (for MEDICAL ENTOMOLOGY, i.e. insects in human disease, see, under that heading, a separate discussion as an independent science). In the United States alone had the conditions of agriculture and horticulture previously been such that the farmers and fruit-growers were compelled to deal with their pests if they were to obtain crops at all; and economic entomology was then developed in America to an extent unknown elsewhere. But this limitation is no longer in effect, and the factors that have combined to bring entomology to its proper place in the sciences that underlie the practice of agriculture and horticulture are simple and clear. So far as relates to the older countries, with an established and ordered system of crop-growing, whose stability and perseverance make in themselves for the minimum of insect prevalence, the comparatively small losses due to pests have now become important owing to the keener competition in crop production, the lowering of values and the

greater care that has to be exercised to make a profit; when agriculture flourished the margin of loss due to pests could be neglected; but this had often approximated, in the last ten years before the World War, so closely to the actual profit that the losses, small though they might be, had of necessity, to be checked. In the tropics, the opening up to cultivation of increasing areas in cotton, tea, sugar, coffee, palms, citrus and specially rubber has brought in its train insects which may entirely inhibit the successful cultivation of the crop if they are not dealt with.

The decade 1910-20 was one of extraordinary developments in the trials of new crops in fresh areas, and it is one of the cardinal principles of modern entomology, as explained below, that the introduction of new crops to new areas stimulates the outburst of immense insect epidemics; the British Dominions and colonies have followed the lead of Cape Colony and the West Indies, and have found the entomologist a necessary officer on the staff of the agricultural department. The first entomologist appointed from the United Kingdom to such work took up his duties at the close of 1899; now a number leave England yearly to replace the vacancies or to fill new posts in the agricultural departments of the Dominions and the colonies of the Empire. A third factor, and one that will increase in importance, has been the immensely increased facilities for the rapid transport of plants and pests from one country to another, and also the increased desire to obtain the new varieties of tropical crops produced by the economic botanists of the tropical agricultural stations. Formerly the Royal Botanic Gardens, Kew, were the British centre of plant distribution, and while Kew was the home of many introduced scale insects, few pests were distributed apart from these; but the new varieties of cane from Java and the West Indies, the cotton seed from Egypt, Cambodia, Australia, the mango seed from the East, the rubber plants that circulated over the tropics, the countless shipments of tropical plants, have been the means of introducing pests to new countries, where, freed from the control of nature by means of natural enemies, they have bred and multiplied to their full extent and so constituted a very serious menace to cultivation. Experience has also shown that the new applied entomology is as practical a science as any other upon which the practice of agriculture depends. This was not always the case, and the amateur entomologist, whose interests were primarily confined to collections and nomenclature, did not impress the practical farmer as able to help him in his fight against enemies; this phase (from Great Britain and India notably) has not wholly passed, but it has so largely given place to the practical entomologist whose object is to eliminate the pest and thereby also the loss, that the entomologist is now recognized as necessary. A final factor is the growing recognition of the value of "team work," that is, of the co-operation of the plant breeder, plant physiologist, mycologist, bacteriologist, and "soil condition" expert, in tackling problems of plant hygiene, and their demand for the collaboration also of the entomologist able to deal with that aspect of the problem. Many insect problems are cases solely of gross damage by feeding insects; but many are tangled up with other disease phenomena, and in many cases an insect is the transmitter from plant to plant of virulent disease organisms. It will be evident that the older type of entomologist, whose interest in the insect ended with its classification and the enumeration of the synonyms under which it was known in the literature, must be replaced by the more widely trained man capable of collaborating in these complicated problems.

**Training.**—In 1900 there were few facilities for training outside of the colleges and experiment stations of the United States, and the entomologist selected for responsible work in the colonies was required to have taken a degree in zoology and to have an amateur knowledge of entomology as then understood. Even in 1910, the English universities provided no better training, and the groundwork of a very thorough education in comparative anatomy and zoology was regarded as the one essential upon which could be laid a small amount of

entomological knowledge. A single British college established in 1911 a fuller course of specialized training, and has since provided a four-year course, designed to teach not only entomology but also so much of allied subjects as to enable the entomologist to collaborate readily and intelligently with his colleagues in plant physiology, plant breeding, mycology, bacteriology; it embraces some training in all these; it is divorced from zoology and the comparative anatomy of animals, except in so far as these are necessary to a wide comprehension of biological questions, and it provides a full and complete training in all aspects of applied entomology; further, a feature is the inclusion of research on some problem of applied entomology as part of the actual training, so that the trained student has had some experience of the kind of problem he will spend his life solving. Progress in this direction was being slowly made up to 1921 at other teaching institutions in Great Britain, but it contrasted poorly with the progress made in the United States in the provision of full facilities for training at many colleges and experiment stations. The problem of economic entomology in England had been to escape from the dominion of the zoologist; the problem in America had been to incorporate sufficient science and to escape the anti-academic demands of the "practical man," to whom science as such did not appeal. It is probably true to say that both countries err, the English in being still too academic, the Americans in being too practical and too little sympathetic with the value of the "scientific" method of thought. This question was discussed at the Conference of Agricultural Entomologists arranged by the Colonial Office in England in June 1920, and while this Conference did not express any definite opinion, feeling was general that the ideal training was a groundwork of general horticultural or agricultural science, with the special training of the entomologist thereafter, and this is very nearly a mean between the present training of the Imperial College in London and that of most of the American colleges. The total number of entomologists required for science in the British Empire was set in 1921 sufficient to justify the provision of facilities for training at a number of universities, and it was possible that the establishment of tropical agricultural colleges might lessen the need of facilities in Great Britain, while providing better training for tropical problems. Careers in entomology had become far wider in 1921 than they were in 1900; in 1920 there was no official entomologist employed in England. The entomologist attached to the Ministry of Agriculture was in 1921 stationed at Harpenden, where he was in close touch with the Phytopathological Institute, with several entomologists employed upon research, and a beginning had been made with the appointment of local entomologists, each to advise a small group of countries and to work on the staff of the institutes designed to assist the progress of agriculture and horticulture. There are entomologists attached to the departments of almost every British colony, and the Dominions of Canada and South Africa maintain larger departments with considerable staffs. India was in 1921 still provided only with a small number of entomologists attached to some of the provincial governments, and had a small teaching and publishing section, not directly concerned with the checking of insect pests, at the Agricultural Research Institute. The most complete economic entomology department in India was that of the Madras Government, but entomologists were attached also to the agricultural departments of the Punjab, United Provinces, Bihar and Orissa, and Burma. A recent phase in the development of this subject is the increasing utilization of entomologists by companies engaged in the cultivation of tea, rubber, sugar-cane and similar products, or by associations of such companies. The Indian Tea Assn., the United Planters' Assn. of South India, the Colonial Sugar Co., and similar organizations in Malaya, Fiji, Jamaica, etc., maintain scientific staffs usually with entomologists, and there are considerable developments, probable, now that the commercial community is realizing that economic entomology can be a sound, practical affair, and not an amateur scientific business of naming insects. In the United States, the develop-

ment of entomology as a career for trained men has probably reached its limit; as the conditions of agriculture stabilize themselves, as the proportion of each crop becomes fixed, as the immense incidence of crop pests characteristic of America will diminish, and it is now probable that the main concern of the entomologist in that continent will be to safeguard the industry against the incursion of fresh pests from abroad. European countries have been developing very much as described above. Before the revolution in Russia, there had been an immense impetus to the development of entomology in that vast country; in France and Italy the entomologist is now being increasingly utilized, and while in Germany the subject had been neglected, since the war the Association of Economic Entomologists has stimulated the development of practical applied entomology. In Japan the development of the subject has come with the increase in scientific departments, and especially with the immensely valuable results derived from research on the silkworm-rearing industry.

**Control of Pests.**—The principles on which it is sought to control and check insect outbreaks developed very markedly during 1920-20 from "artificial control" based upon direct remedies and insecticides, to "natural control" based upon an understanding of the factors that produce outbreaks of pests and action arising from that knowledge. The first essential is a really intimate knowledge of the pest itself, its habits in all its stages, its senses and sense organs, its (almost) daily ways in the most minute particulars. It is now recognized that this must be carried to a degree of detail not contemplated before, and that upon the intimacy of this knowledge depends the successful application of any direct method. It is not sufficient to know that eggs are laid in such a way, in such number, at such a time, that the larvae moult so many times, feed in such and such a way and pupate, that the pupa takes a certain time, and then the adult emerges to mate, lays eggs and dies. An instance may be taken from the Codlin moth, whose larva hibernates in the winter in shelter; the full-grown larva leaves the fruit, crawls about, and for shelter will get under a flake of bark, spin a light cocoon and there remain. Will it do this on the trunk and branches, on the north (exposed) or the south (sunny) side, must the bark be dead or alive, will it prefer a band of bast, cotton, jute, wool, silk or what? Must it be double or single, tied on tightly or loosely, all round, at what height, when put on, when taken off? The investigator has to try to put himself as far as he can into the mentality of the insect, and the success of the entomologist depends much upon this instinct, which will yet be much developed. The second essential is a study of controls; what is it that, in its native habitat, checks the increase of the insect? Is it climate, food, plant scarcity, parasites, predaceous insects, birds, bats, lizards, frogs, etc., or disease due to fungi or bacteria? Usually it is direct parasites, predaceous insects, and perhaps, under suitable climatic conditions, disease due to fungi, bacteria or a virus. It is these natural checks which, in natural conditions, balance the rate of increase of the insect, which is large. The third essential is the nature of the conditions which produce an increase of the insect to such a point that it becomes a pest, that is, so injurious as to affect the crop yield materially. Normally there is under undisturbed natural conditions a balance of life; the checks and the natural increase of the insect are so balanced, in nature, that the insect never increases to a point of being destructive. But under artificial conditions of cultivation, man disturbs this balance; he clears land, disturbing the ratio of plant life; he interferes with the bird life particularly; he plants areas with crops, i.e., an unmixcd plant area, which favours the increase of any insect capable of feeding upon that crop, since the parent insect has not to undergo a precarious hunt from plant to plant for the proper food plant for its young, but finds an unmixcd block, thereby escaping many dangers. In addition, man introduces blocks of new crop plants, which have not acquired protection against indigenous insects, and which are at once attacked, lacking the protection they will in time develop. These are some of the factors

by which man's artificial cultivation of crops disturbs the delicate balance of life, and produces those fluctuations or "waves" of insect abundance which the entomologist recognizes as pest outbreaks that he has to deal with. If he can be he has to trace to their origin these waves of increase, and the modern science of entomology is to do this as far as may be. In many cases the problem is the simple one of determining if the insect is an introduced one; if it is, it has probably been introduced without the natural enemies that checked it in its original home; and it is due to the work of an Englishman, R. C. L. Perkins, that this principle was applied in the Sandwich Is. against the insect so seriously destructive to the sugar-cane crop, the Cane-leaf-hopper (*Perkinsiella saccharicida*). Its natural home is Australia. Study of the insect there showed it to be kept in check by a variety of insects, some of which were introduced to the Sandwich Is., eventually reducing the insect to the status of an ordinary insect, not a pest. This principle has been followed in other cases, notably the Fluted Scale of Orange (*Cercya purchasi*), the Gypsy Moth in the United States (*Portheia dispar*), the Brown-tail Moth (*Euproctis chrysothoea*) in the United States, the Sugar-cane Cockchafer of Mauritius (*Phylolus Smithii*); it is the natural principle to proceed upon in the case of introduced insects and it has been developed especially in the United States, which owes to importation so many of its principal pests.

In other cases the disturbance and consequent occurrence of pests is due to violent alterations in the proportions of the crops grown. Where there has been, as in England, a fairly uniform mixed cultivation of many crops over a long period, a balance of life has been established as under natural conditions; but where the variations in supply cause fluctuations in prices and large areas are put under other crops, this balance is disturbed, and there are waves of insect pests; naturally this manifests itself far more quickly under tropical conditions, where there are several broods of an insect a year, than under temperate conditions, where there is only one brood a year with a long resting period, and it is partly this factor which makes for the very great loss from insect pests in the tropics.

Having obtained any data as to the factors producing an outbreak, it is to be seen whether there is any way of quickly restoring the balance of life, or of so modifying cultural practice as to avoid the outbreak, and it is to this that the entomologists' attention is specially directed. The nature of the rotation of crops, the time of sowing, the use of early or late maturing varieties, these are important points; a further point is on what food plants or under what conditions the insect spends the time when the crop is not on the ground or is not fruiting, and modern entomology emphasizes more definitely the value of the old maxim of clean cultivation, of growing only crops, with nothing on the land besides—no weeds, no alternative food plants, no "volunteer" plants. This is particularly the case with permanent cultivation such as fruit or such tropical crops as tea, coffee, cacao, rubber and the like.

A point of great interest, which has as yet been scarcely touched, is that of "immunity," whether natural or induced. The discovery that American vine stocks were immune to Phylloxera, since they had always been exposed to it in America, whence Phylloxera came, did much to save the European vine industry; there are stocks of apple which are apparently immune to the root forms of woolly aphid (*Schizoneura lanigera*); vigorous plants growing under good conditions are frequently "immune" to attacks of such sucking insects as Leaf-hoppers (*Jassidae*), Scale Insects (*Coccidae*), *Psyllidae* and White Fly (*Aleurodes*). This question is far more developed in the case of Fungi (e.g. rust in wheat) than in that of insects; but it is a question which has come more definitely to the front during the past few years. It is not at present possible to induce immunity, but it may soon be possible to do so.

The fourth point in the entomologists' plan is that of the utilization of direct remedies, such as insecticides, fumigants, and soil insecticides. There was a considerable modification in opinion during 1910-20, and but for the large propaganda by

insecticide firms, the use of these artificial methods would have considerably declined. In the actual practice of spraying there have been few improvements and no radical changes. The arsenates, nicotine, lime, sulphur, soaps, these are still the principal insecticides; heavy oil emulsions have replaced paraffin, and the present tendency is to seek farther afield for new and more toxic substances. But progress has been small, there has been little systematic investigation, and there are only differences in detail in the use of insecticides and spraying-machines.

A feature of the development of the subject has been the broadening of knowledge among farmers, fruit-growers and even the general public, particularly in the United States, but also in Europe. In England, publicity and propaganda campaigns have been mainly concerned with the house fly, and there is still great ignorance about other pests; but this is passing with the increase of nature-study and the greater development of natural-history societies in schools.

**Legislation.**—Experience of the value of legislation in regard to the spread of plant pests and to their destruction has resulted in a very definite simplification of the laws and enactments relating to insect pests, and a conference of delegates of 26 nations in Feb. 1914 at Rome formulated the Rome convention, which still further simplifies the principles governing the regulation of plant traffic from country to country.

Almost every country now seeks to protect itself against new pests, which, introduced without natural checks, become immensely active and destructive in a new habitat. These measures were very varied and are now simpler, and when a convention is established finally, it will probably rely upon one definite principle; but there is still some variety. Countries seek to protect themselves by prohibiting the import of plants from a specified locality, of specified plants, of anything likely to cause disease, of insects, or of packing with infested articles; so, for instance, a sugar-growing country prohibits the importation of canes, and also, perhaps, of all plants from an area in which a virulent insect pest is active.

An alternative is to permit importation under conditions; ports of entry may be designated at which alone plants come in, the plant imports may be limited to special times, or must be in new packages, or only in postal packets. The most general condition is inspection on arrival by a competent officer, who may order their destruction if infested with a pest, or the plants must be fumigated on arrival, this being done usually with hydrocyanic-acid gas generated from potassium cyanide and sulphuric acid, the amount used being about 2 oz. cyanide per 100 cu. ft. space for half an hour.

Formerly great stress was laid on the value of quarantine; all plant imports were grown in a quarantine ground under the supervision of a Government botanist until it was certain that they had no disease. The objection was that if the plant was diseased the disease was brought into the country and, whatever the supervision of the botanist, might get loose and spread; an alternative to quarantine was "following up"; the importer notified the arrival of plants and the exact spot where he planted them; a supervising officer at intervals in order to destroy them if any disease developed. A more recent principle is that of admitting plants without delay if they were accompanied by a certificate that they had been inspected by an official of the Agricultural Department of the exporting country, and were declared free of pests scheduled by the importing country, or that they had been grown in an area declared free of the scheduled pest. The latter applied particularly to *Phylloxera* of vine; the former applies to the schedule of pests drawn up in each country, and this is the principle accepted by the Rome convention of 1914. Each country is to draw up a schedule of pests which are not epidemic in that country but which are recognized pests, and any country sending plants will have an adequate service of trained inspectors to give certificates that either the nursery sending the plants, or the actual consignment, is free of pests. This cannot be done without a "Phytopathological Service," so that the consenting countries bound themselves to create this, and this has to some extent been done in Great Britain, France, Italy, Holland, Belgium. The United States refused even to discuss the question, and has adopted drastic inspection and certificates of freedom from pests, but experience has shown it that few certificates are reliable and it is not willing to receive consignments from any country whose certificates are not really of established value (e.g. those of Holland are accepted).

A further difficulty is that plants may come from countries not able to give certificates, e.g. Tibet, and these plants are very liable to introduce disease. Inspection on arrival is the usual method but an effort has been made to enable such plants to be grown under quarantine when imported by a firm of established reputation in Great Britain, so as to avoid the risks of unpacking at the port.

Internal legislation, prescribing action on the part of growers, has made progress during recent years, and has been very much simplified. In Great Britain the sale of diseased-plants order of 1921 puts a penalty on the sale of plants "substantially attacked."

by a number of common insects and fungi. The actual enforcement of the order generally would require the services of many thousands of officials, and would be impossible, but it is designed to give powers to the Ministry of Agriculture to proceed against any nursery notorious for distributing diseased plants, and also to enable the Ministry to act freely in case of a new pest being introduced.

In America and the British Dominions such legislation is common. It prohibits the possession of diseased plants, the sale of infested plants, the sale of plants from an infested area, the removal from declared areas of plants, cases, bags, packages, earth, manure and even of persons; it is often aimed entirely at nurseries and seeks to control the distribution of plants; nurseries must be registered, must be inspected at fixed intervals, must send out certificates of inspection with all consignments, and may, if infested with a scheduled pest, be quarantined; and there are the usual provisions as to entry, to prescribing remedies, to penalties for non-compliance. The treatments of infested plants by the owner or by the State are prescribed, or the destruction, isolation or confiscation of infested plants. Further provisions are to compel destruction of insect breeding-places, and to prohibit the planting in infested land or within a certain distance of infested land.

In many countries, as in Great Britain, the occupier of land has to notify the occurrence of any of the scheduled pests to the Ministry of Agriculture and in some tropical countries there is a specific prohibition of the practice of driving locusts to one's neighbour's land. The tendency is to rely less on legislation, compulsion and penalties, and to move more towards education and reason. The spirit which enabled a Government to close all schools, courts, places of business, etc., while a whole province fought locusts, exists only in the least civilized areas of the earth, and the campaign against pests is carried on by propaganda, education and the arousing of public spirit.

**Insects and Crops.**—The importance of insect attacks as factors in the growth of crops varies from the case of cotton, where the insect is a dominant factor, equal in value to soil and climate, to that of rubber, where as yet scarcely any serious insect pest has arisen, certainly none equivalent to the fungoid diseases.

Cotton was formerly produced mainly in the southern United States. There the bollworm was the chief pest, causing loss that now averages some £2,500,000 annually, but in 1894 the Boll Weevil appeared in Texas, and in 1905 Dr. L. O. Howard, Chief of the Entomological Bureau of the United States Department of Agriculture, wrote:—"The Mexican Cotton Boll Weevil has the unique record of developing in less than 20 years from a most obscure species to undoubtedly one of the most important economically in the world. There was a hope that the increase in cotton in the United States would keep pace with the world's demands; now the weevil has rendered this impossible."

The damage is now averaged at about £5,000,000 annually. But there is worse to come. Another pest has been known in India since 1844; this is the Pink Bollworm, which reached Egypt between 1903 and 1910. There they already had another bollworm; but by 1917 the Pink Bollworm was destroying on the average 17% of the crop, causing a loss of £8,000,000 a year, and this pest reached Texas in 1917. In spite of the efforts of the U.S. Department of Agriculture it was established there in 1921, and in a few years it seems likely to destroy 2,000,000 bales, worth, say, £60,000,000.

Nor are these the only pests of first-rate importance. In India the Spotted Bollworm is a pest which also attacks Egyptian cotton. In 1905 this pest almost entirely destroyed the cotton crop of the Punjab and Sind, and it was known in 1921 only in India, Egypt, the Sudan and British East Africa.

The chief cotton-producing countries are listed here with the pests they have; what if the pests spread to all? The output is that of 1917:

	Acres	Bales	Pests
United States of America	33,841,000	11,309,375	H.A.P.E.
India	24,781,000	3,228,800	H.E.
Egypt	1,761,000	1,287,000	P.E.
China	(340,000)	830,000	
Russia		578,000	
Brazil		460,000	A.P.
Mexico		225,000	A.P.
Peru		110,000	
Indo-China		80,000	
Corea		200,000	
Nigeria		2,621	
Nyasaland		4,448	H.E.
Uganda		20,000	H.E.
West Indies		3,000	P.H.

*Heliobis armigera*, the American Bollworm.—It attacks cotton in America but, while it occurs universally in the tropics, does not, in India, attack any cotton but *Cambodia*.

*A. ulmivorus gravis*—Mexican Boll Weevil.

*P. platydra (Glechia) gossypella*—Pink Bollworm.

*E. earis insulana*—Spotted Bollworm.

Apart from cotton, the actual limiting effect of insect pests is less definite but it is a notable factor in many tropical crops: sugar-cane

suffers heavily from two pests; moth-borers and cane-leaf-hoppers, the loss from one species alone is, in Barbados, estimated at over 15%. With sugar selling at £15 per ton, this means a loss of 16 per acre, and this loss is avoidable by a small expenditure; but the crop is grown, the expenses of rent, management, cultivation, manuring, harvesting, manufacturing are all incurred, on canes diseased and affected by this pest, and the net result is a decreased yield, expenses being still the same, of some 56 per acre.

A similar situation occurs with nearly all crops, but it is difficult to say definitely what proportion of the loss is due to insects. In England, Green Fly may ruin the hope, frequently ruins the plan crop; in America a long cold spring gives the Spring Grain aphid scope to increase, and decreases the yield of wheat, and affects every wheat sale in the world, or a wet summer destroys Chinch Bug, and the wheat crop increases next year with bigger supplies and lower prices. Of the many factors influencing wheat prices, insects are only a small one, but they may be, in some years, just the determining factor, since the factors of climate, rainfall, weather, production, transport, speculation may all be steady.

**Stock Raising, Building and Grain Storage.**—Insects are not only factors in crop production, but in stock raising, in building protection, and in grain storage. The best example of the first is in the Blowfly pest of sheep in Europe, Australia, S. Africa, Argentina and other places. The loss of stock in Australia in 1916 amounted to £3,000,000, and the production of wool and meat in Australia will depend very much on whether control is obtained over this pest. In 1921 no real effort had been made to control it; but it will eventually be controlled, probably by the introduction of natural enemies and by the employment of substances protecting the animal from attack.

The importance of insects in buildings in Great Britain has been emphasized by the discovery that the glorious timber roof of Westminster Hall was in a dangerous condition owing to the attacks of the Death Watch (*Xestobium rufohilum* or *exsectatum*). It was found that the timbers were destroyed to a very remarkable extent, and I.L.N. Office of Works embarked on a scheme of strengthening the roof with an invisible steel frame while preserving intact as much of the timber as possible. It was essential not only to stop the activity of insects but to protect the timber from further infestation, and the solution was found in a treatment by which all infested timber is freed of the pest by dichlorobenzene, and all surfaces are impregnated with a coat of soap, paraffin wax and cedarwood oil, which prevents further insect attack. This method has been applied to other buildings, notably St. Paul's Cathedral.

A war problem of importance in which entomology was concerned was connected with the preservation of the accumulated wheat stocks in Australia. In 1917 there was a stock of some three million tons of wheat in bags in Australia, with another similar amount to be harvested. All was stored in the open, since no other storage was possible, the wheat usually being shipped immediately, and the result of storage under bad conditions was an immense infestation by weevil (*Calandra oryzae*), threatening the complete loss of a stock of wheat urgently required for the Allied countries. Two problems needed to be solved, the storage of wheat and the freeing from weevil of the already infested wheat harvested in 1916 and 1917, and the awaiting shipment. Since the Australian Government were unable to deal with this problem it was necessary for the British Wheat Commission to undertake it, and the solution was found in a method of storage which prevented access of weevil and in a treatment by heat on a large scale, so that in a single plant 1,000 bus. per hour were heated for three minutes to 140°F., killing all stages of the weevil and giving a weevil-free wheat suitable for milling and baking. This treatment cost less than one penny per bus. and enabled Australia to ship 200,000,000 bus. of wheat which was otherwise becoming totally unusable or unuseable. (H. M. L.)

**ECUADOR.** (See 8,910).—The population of Ecuador was not altered much during the period 1910-20. Immigration was very slight. No census had been taken. In 1920, an official estimate gave the pop. as 1,500,000.

**Government.**—In a message to Congress in 1914, President Plaza G. raised the question whether or not presidential government in Ecuador had met the test of experience. Upon that subject he held conferences with the members of a special committee of the Chamber of Deputies and hoped that, as a result of its report, a joint committee from both Houses of Congress would be appointed to draw up a project for the reform of the constitution of 1906. The Senate, however, did not favour this action. President Plaza G. again mentioned the urgent need of constitutional reform in his message to Congress of Aug. 10 1915. Upon the following day he addressed a special message to Congress proposing the political reorganization of Ecuador by the introduction of the parliamentary system. Annexed to his message were certain proposed amendments of Ecuador's fundamental law which were framed to accomplish this end.

These, however, were not accepted by Congress. On Jan. 28, 1917, President Baquerizo M. promulgated a decree regulating the duties of his Cabinet. The Minister of the Interior was to be charged with internal administration, municipalities, police, prisons, houses of correction, public works, railways, sanitation, concessions, and with government of the province of Oriente and the Galápagos Islands. The Minister of Foreign Relations was to have direction of international affairs, consuls, post-offices, telegraphs, telephones, immigration, and colonization. The Minister of Public Instruction was to be charged with public instruction, statistics and civil registry, fine arts, theatres, charity, justice, religion, agriculture, improvements and national forests. The Minister of Finance was to supervise the collection of the national revenues; the auditing of accounts, public credit, the administration of national property, commerce, public lands and trade-marks. The Minister of War and the Navy was to control the regular army, reserves, war vessels and lighthouses. By a decree of Sept. 22, 1910, the control of the province of Oriente and the Galápagos Islands was transferred to the Minister of Foreign Relations.

**Communications.**—In recent years measures were taken by the national Government for the improvement of roads, most of which were merely trails or bridle-paths. Some internal traffic was carried on by the rivers, especially by the Guayas river and the tributaries of the Amazon. The most important railway was the Guayaquil and Quito railway, opened to traffic in 1908. To shorten the route between these two cities the Government planned a railway between San Juan Chisio and Riobamba. Other short railways were projected, and in some cases partly completed. A contract was signed whereby a railway was to be built from Quito to Ibarra, thence to Tulcán, and to the coast in the province of Esmeraldas. Surveys were made and construction was begun on a section of the roadbed near Ibarra in Aug. 1917. Construction was begun also on a railway between Ambato and Curaray in Jan. 1913. By June 1918, the section between Ambato and Pelileo was practically completed. In 1914 work was begun on a railway between Huigra and Cuenca. After some preliminary surveys had been made the Government decided in Aug. 1915 to build it from Sibarba to Cuenca, and actual construction began the following month. A railway projected between Bahía and Quito had, by 1917, been built and opened as far as Chone. In 1913, one was completed between the airport of Manta and Portoviejo, and by 1915 that road had been opened to Santa Ana. A short railway was begun in 1914 between Guayaquil and Salinas, and another was being constructed in 1920 between Babahoyo and Guaranda. During a large portion of the year 1920 Ecuador was almost isolated from the world by sea; for, because of the prevalence of the bubonic plague and of yellow fever at Guayaquil, that port was avoided by large vessels. In April 1914, a radio station was officially opened at Quito and wireless communication was established with a small station in Guayaquil.

**Sanitation.**—Sanitary work was begun seriously when, in Dec. 1913, a contract was signed between the Ecuadorian Government and White & Co., of London, for the paving of Guayaquil and the installation of a modern water system. A yellow-fever commission of the Rockefeller Foundation made a scientific study of Guayaquil in 1916. A fight against the fever was, however, postponed because of the World War. In 1918 squads of men under Col. Gorgas began a scientific attack upon the *Anopheles* mosquito in Ecuador. So successful was this campaign that, on May 27, 1920, the director-general of public health at Guayaquil issued a statement that yellow fever had been eradicated from that city as well as from the towns in the provinces of Guayas, Los Rios, and El Oro, where it had been endemic.

**Foreign Commerce.**—There was some fluctuation in Ecuador's imports and exports from 1920 to 1918, but not much increase. Figures compiled by the Pan-American Union show that in 1913 the imports of Ecuador amounted to \$8,836,889 U.S. dollars, that her exports in that year amounted to \$15,789,367. In 1918 her imports amounted to \$8,171,693, while her exports came to \$18,364,774, in both cases a decrease. Her import and export trade with the United States had grown greatly at the expense of trade with European countries. In 1913 imports from the United States amounted to \$2,817,754; in 1918 they aggregated \$4,632,761. In 1913, out of a total export trade of \$15,789,367 her exports to the United States came to \$3,833,728, while in 1918 they amounted to \$10,459,150. Among Ecuador's most important imports in 1918 were textiles (other than silk), food-stuffs, hardware, machinery, paper, and perfumes; while her most important exports were cacao, ivory nuts, Panama hats, coffee, gold and wool.

**Army and Navy.**—In 1917 the navy of Ecuador was composed of a destroyer, a cruiser, a coastguard vessel, a submarine, a launch, and a tender, with a small personnel. The territory of the republic had been divided into six military zones which were in charge of army officers. A general staff was in control of the regular army, made up of 10 battalions of infantry, two squadrons of cavalry, three

regiments of artillery and a company of engineers. The regular army, including officers, numbered 5,200.

**Education.**—Although by a law of Ecuador primary education was free and attendance compulsory, the percentage of illiteracy was high. In 1914 an Ecuadorian writer estimated that over 70% of children from 5 to 14 years of age were illiterate. In a message to Congress in Aug. 1915, the President stated that there were in Ecuador 1,054 primary schools with an attendance of 95,019 pupils. Secondary education was being conducted in 23 national *colegios* (academies) with 3,776 students. In addition there were schools for professional or technical training: normal schools, a school of agriculture, schools of arts and trades, a school of fine arts, and a national conservatory of music. Later commercial schools were founded in important cities. In 1916 and 1917 decrees were issued reorganizing the curricula of several schools, of the school of arts and trades at Quito, and of the national military academy. In 1917 the President decreed the establishment at Quito of a museum of archaeology and of a national gallery of painting and sculpture. Higher education is carried on in universities at Cuenca, Guayaquil and Quito. The central university of Ecuador at Quito is composed of colleges of science, medicine and law. The younger universities at Guayaquil and Cuenca have colleges of law, medicine and pharmacy.

**Finance.**—In Ecuador's budget for 1914 the revenues and the expenditures were balanced at 20,441,955.02 sucres (nominal value \$6.46, or one-tenth part of a sterling); the income for that year, however, amounted only to 16,913,768.97 sucres, while the expenditure came to 20,220,794.83 sucres. Revenues from import duties which were estimated at 10,883,055.02 sucres came only to 7,707,191.26 sucres. The end of the year left the Government with a deficit of 3,307,007.06 sucres. This deficit would have been larger but for certain economies and the postponement of some payments. In 1915, partly because of the decrease in import revenues due to the World War, Ecuador had to borrow 20,000,000 sucres from local banks. The Minister of Finance announced that on Dec. 31, 1917, her domestic debt amounted to 34,091,651.04 sucres, while her foreign debt came to 18,622,508.10 sucres, making the total debt, 52,714,159.14 sucres. Of the domestic debt 131,547.27 sucres and of the foreign debt 6,618,115.04 sucres were interest unpaid. The minister stated that up to Dec. 31, 1917, the service of the foreign debt in interest and amortization was in arrears 19,710,476.56 sucres, because of the decrease in revenues.

**History.**—Gen. Eloy Alfaro's term as president expired Aug. 31, 1911. On Aug. 12, however, he resigned the presidency, and his resignation was accepted by Congress two days later. Emilio Estrada, who was elected in Jan. 1911, was inaugurated Aug. 31, but died Dec. 21 following. Dr. Carlos Freile Z., president of the Senate, who had served as chief executive upon the resignation of Alfaro, again assumed executive authority; which he exercised until March 5, 1912. Meantime a revolt, having as its object the overthrow of the legal Government and the establishment of Gen. Alfaro as supreme magistrate, was quelled. That leader was taken out of the penitentiary at Quito by the infuriated populace and killed in Jan. 1912. Acting President Freile Z. was succeeded by Dr. Francisco Andrade Marín, speaker of the Chamber of Deputies, who exercised presidential authority from March 6 to Aug. 10, when Dr. Alfredo Baquerizo M., president of the Senate, took the reins of power and served as president until Aug. 31, 1912. Upon that day, as the result of a special election held in April, Gen. Leonidas Plaza G. was inaugurated as president for his second term. He selected Alfredo Baquerizo M. as his Minister for Foreign Affairs, who was succeeded by R. H. Elizalde. The first years of his administration were stormy, being marked by revolts and civil wars. Even after a troublesome insurgent leader, Gen. Carlos Concha Torres, was captured by Government soldiers in Feb. 1915, his followers were loath to lay down their arms. In elections held in Jan. 1916, Alfredo Baquerizo M., a Liberal, was elected president; he was inaugurated on Aug. 31. Various steps were taken by the President and Congress to lessen the economic and fiscal strain due to the World War. Embarrassing disputes arose between Ecuador and the Guayaquil & Quito Railway Co. about the execution of their engagements. On Aug. 31, 1920, Dr. José L. Tamayo was inaugurated as president for the term to Sept. 1, 1924.

**International Relations.**—Part of the territory claimed by both Ecuador and Peru has been occupied by Peruvians. Provision was made for the settlement of the boundary dispute between Ecuador and Colombia by a treaty signed at Bogotá, July 15, 1916. This treaty drew a boundary line between Ecuador and Colombia; it also stipulated that a mixed commission



should be appointed to place marks along that line where natural boundaries were not sufficient and to make such minor reciprocal compensations of territory as might be necessary to fix the boundary exactly. That commission began the delimitation of the Colombian-Ecuadorian frontier line about a year later, and it completed the task by July 1919.

**The World War.**—On Aug. 17 1914, the Ecuadorian Government issued a decree announcing that it would observe the strictest neutrality in the World War and stating that it would adhere to the Hague Convention of 1917 and to the general principles of international law. Soon afterwards France and England complained that Ecuador had permitted violations of neutrality, allowing German war vessels to use the Galápagos Is. as a naval base. On Nov. 21 1914, Minister Elizalde issued a justificatory circular to American chancelleries about the neutrality of his Government. Seven days later President Plaza G. issued a decree containing certain regulations that were to be observed by all neutral vessels reaching Ecuador. In Oct. 1917, when the ex-German minister to Peru, von Perl, who was also representative of his Government to Ecuador, expressed his intention to proceed from Lima to Quito, he was informed by the Ecuadorian minister at Lima that his reception by Ecuador would be incompatible with the principles of American solidarity. On Dec. 8 following, the Minister of Foreign Relations sent cablesgrams to Ecuadorian legations stating that Ecuador had severed relations with Germany. As a party to the Treaty of Peace with Germany, Ecuador had the opportunity of becoming a member of the League of Nations. At the instance of its committee on foreign relations, on Nov. 1 1920 the Ecuadorian Senate postponed action upon the League until the next meeting of Congress.

• See *Annual Report of the Council of the Corporation of Foreign Bondholders* (London, 1910—); *Anuario de Legislación Ecuatoriana* (Quito, 1911—); *Boletín Estadístico Comercial y de la Hacienda Pública* (Quito, 1910—); *Circular a las Cancillerías americanas acerca de la Neutralidad del Ecuador* (Quito, 1914—); *El Ecuador Guía Comercial, Agrícola e Industrial de la República* (Quito, 1911); A. Espinosa Tamayo, *El Problema de la Enseñanza en el Ecuador* (Quito, 1916); *Informe del Ministro del Hacienda y Crédito Público a la Nación* (Quito, 1915); *Informe del Ministerio de Obras Públicas* (Quito, 1918); *Mensaje del Presidente de la República al Congreso Nacional* (Quito, 1910—); *Monthly Bulletin of the International Bureau of the American Republics* (Washington, 1910—); *Pan-American Union, Ecuador, General Descriptive Data* (Washington, 1909—); *Proceedings of the First Pan-American Financial Conference* (Washington, 1915); *The Rockefeller Foundation. Annual Report* (New York, 1916).

(W. S. Ro.)

**EDINBURGH, Scotland** (see 8,937).—By the passage of the Edinburgh Boundaries Extension Act of 1920 Edinburgh has become, as far as area is concerned, the second largest city in the United Kingdom, through an amalgamation with Leith, and the absorption of the suburban districts of Liberton, Colinton, Corstorphine, and Cramond. The municipal area was increased from 10,597 to 32,402 acres.

The number of municipal wards has been increased from 16 to 23 and the number of members of the town council from 59 to 71—three representatives of each ward in addition to the two *ex officio* members, the dean of guild and the convener of the trades. The four Leith wards form the parliamentary division of Leith, and the four new suburban wards are in the northern division of Midlothian and Peebles. The powers of the board of trustees under the Edinburgh Waterworks Acts of 1869, 1874, and 1896 and of the Edinburgh and Leith corporations gas commissioners are now exercised by the town council. The total valuation, as extended, is £4,696,504.

The pop. of Edinburgh by the 1911 census was 320,315, of Leith 80,488, of Liberton 8,360, of Colinton 6,664, of Corstorphine 3,870, and of Cramond 3,763—a total of 423,460 for the extended city. The estimated pop. in 1920 was 450,000. In 1917, the corporation agreed to purchase the plant of the Edinburgh Tramway Co., for £90,000, and the transfer took place in July 1919, at the expiry of the company's lease. The work of replacing the system of cable cars was begun in 1910. A tramway extension to South Queensferry and Port Edgar was sanctioned by the town council in 1917. The most important addition to the public parks was the establishment by the Zoological Society of Scotland, in conjunction with the town council, of a zoological park at Corstorphine hill, which was opened in July 1913. The site, which extends to 74 ac., was purchased by the town council and feued to the society. About 27 ac. have been laid out in a manner designed to give expression to the latest ideas

about the acclimatization and exhibition of wild animals, and to show the inmates living under conditions which invite them to display their normal instincts and habits. The park contains a large and varied collection, and when completed will rival the London "Zoo." Large corporation markets and slaughter-houses were opened in 1910, and in March 1914 the Usher hall, bequeathed to the city in 1898 by Mr. Andrew Usher, was completed and opened.

Additions to the large number of public memorials in the city include a Black Watch memorial (1910), a statue of Dr. Guthrie (1910), a life-size statue of Thomas Carlyle (by Boehm) presented to the National gallery by Lord Rosebery in 1916, and a Gladstone memorial (1917). In 1913, Lord Rosebery presented to the city the historic house in the Lawnmarket known as Lady Stair's house, and in 1920, the birthplace of Robert Louis Stevenson, 8, Howard Place, was purchased as a memorial by the R. L. Stevenson club. In 1911, the King and Queen dedicated the new chapel of the Order of the Thistle, in St. Giles' cathedral. The new Freemasons' hall was opened in the same year. The western spires of St. Mary's cathedral (carrying out the original plan of Sir Gilbert Scott) were completed and dedicated in 1915 and 1917. Reconstructions of the national museum of antiquities and of the national portrait gallery were in progress in 1920, and a scheme for a national war memorial provided for the utilization for this purpose of Edinburgh castle, which was to be disused as barracks.

Royal residence at Holyrood had emphasized the social position of Edinburgh as the capital of Scotland, and its importance as an administrative centre tended rather to increase than to diminish, as new government departments were established. Its commercial importance depends upon its being the headquarters of many of the Scottish banks and insurance companies and of the North British Railway Co., upon the continuance of its traditional position as the chief centre for the administration of Scottish landed estates and upon its preëminence in the legal world. Apart from the business of the high courts, Edinburgh firms of writers and chartered accountants are entrusted with a large proportion of Scottish legal and administrative work.

During the World War the proximity of Edinburgh to Queensferry and Port Edgar and the great battle cruiser and destroyer base in the Firth of Forth gave it strategic importance in the naval operations, and its position as the headquarters of the Scottish command made it a centre of military organization. Preparation for defence against an invasion by sea were made in its vicinity as in other coastal districts, but no serious anti-aircraft protection was given until after a Zeppelin raid, on April 2 1916, in which ten people were killed and eleven seriously injured and damage was done to warehouses, private houses, and public buildings including Donaldson's hospital. In the later stages of the war Edinburgh became a favourite leave centre for colonial and American troops.

**EDISON, THOMAS ALVA** (1847— ), American inventor (see 8,946), made great progress after 1910 in perfecting a battery of large storage capacity for propelling vehicles. This proved of great service, for example, in moving baggage trucks at railway stations. He hoped to produce, with Henry Ford, an automobile so propelled. He was specially interested in the cinema, and early in 1913 displayed the first talking picture, produced by synchronizing the motion-picture and the phonograph. Although as yet unperfected, the inventor believed that such pictures were destined largely to replace text-books in the schools. On the outbreak of the World War he urged "potential preparedness" through mobilizing facilities for research in America, on the ground that "future soldiers will be machinists." In 1915 he was awarded a Nobel prize for physics and the same year was made president of the Naval Consulting Board. After America's entrance into the World War he was in charge of several plants manufacturing chemicals used in warfare. In 1916 he announced a portable searchlight, fed by a storage battery, far more powerful than the acetylene lamp, for use amid smoke in mine rescues, train wrecks, etc.

**EDMONTON**, the capital of the province of Alberta, Canada (see 8,946), first established as a trading post by the Hudson Bay Co. in 1795, remained little more than a village until 1901. Since then its growth has been rapid, and in 1920 it had a pop. of 67,000. Edmonton has 5 railways with 13 radiating lines, and is the terminus of the Calgary and Edmonton branch of the Canadian Pacific Railway. The city council consists of a mayor and 10 aldermen elected from the city at large—the mayor for one year and aldermen for two—and the mayor and two commissioners act as a board for administration. There is also an elected board of six public school trustees, and another elected board of trustees for the separate (Roman Catholic) schools. The Supreme Court sits at Edmonton several times a year. Edmonton

\* These figures indicate the volume and page number of the previous article.

is the chief educational centre of the province, and besides the university of Alberta has a branch of the Normal school, Alberta College, Westminster Ladies' College and a Presbyterian college.

Edmonton has extensive live-stock, dairy, milling and packing industries. There are 9 coal mines within the city limits and 24 on the outskirts, giving a yearly output of 1,680,000 tons. Gold, silver and oil are also found in the neighbourhood.

**EDMUNDS, GEORGE FRANKLIN** (1828-1919), American lawyer and political leader (see 8.949); died in Pasadena, Cal., Feb. 27 1919.

**EDUCATION** (see 8.951).—In the sections on Education, in the articles on various countries, mention is made of the progress made there during 1910-20. Here a general account is given of progress in the United Kingdom and the United States.

#### (1) UNITED KINGDOM

The first two decades in the 20th century opened a new era in the history of education in the United Kingdom. In England and Wales the Act of 1902 not only combined in a national system of elementary education both voluntary and state schools, but laid a wider foundation for a national system of secondary education. It was an Act which represented the spirit of compromise. It gave a new expression in one most important group of institutions to the English genius of harmonizing diverse elements within the State. At the same time the Act marked a great experiment in local government, by transferring the responsibilities for education, elementary and secondary, from the *ad hoc* school boards in England and Wales to the municipal and county councils, and bringing education thereby into closer relations with the other sides of civic policy.

It is necessary to the understanding of the development of English education between 1910 and 1920 to keep in view this fundamental change at the beginning of the century. For during these first 10 years the system of education was taking on a new character, which reflects a wider conception of education. The school becomes more publicly recognized as a great centre of social influence. Provision is made by statute to secure in necessitous cases that school children shall be properly fed. Inspection of the health of school children becomes a responsibility of the local education authorities. Increased attention is directed to the special problems of physically and mentally defective children. The care also for the leisure hours of the child and the provision of play centres become part of school life; and the creation of juvenile employment organizations, in connexion with the school, express the continuity of the elementary school with the after life and care of the child. Side by side with these developments there can also be observed a remarkable growth of corporate life amongst school children themselves, and of voluntary organization of social workers, anxious to help in the ways of the juvenile community. It is not too much to say that a broader human outlook marks English and Welsh elementary education in the first 20 years of the 20th century. And this is no less true of education in Scotland.

Meanwhile, a deeper sense of the need for secondary and continuation education was also awakened. The growth in the number and variety of continuation classes under the local education authorities, the rise of the Workers' Educational Assn. and of the university tutorial classes system are all signs of the new order in education. What this means in progress can only be realized by looking backward and reflecting how modern is the growth of the system of English public education. When the mind follows the story of education in England from 1831, when first small grant was made by Parliament for public education, the opening decades of the 20th century stand out above all as calling into consciousness a deeper and wider idea of national public education.

The second decade of the 20th century marks in a very peculiar degree the continuation and working out of the movements which had manifested themselves in the preceding 10 years. The great Act of 1918, with the corresponding Education (Scotland) Act, extended and deepened the work of the 1902 Act in England and Wales and of the 1908 Act in Scotland. The principles of

organization and the ideas of the relationships between the school and society, developed in the legislation and administration of the period 1907 to 1910, were being progressively carried out in the years immediately following. But the second decade of the 20th century is broken and deeply affected by the years of war. In these 10 years three periods may be distinguished. The first from 1910 to the outbreak of war in 1914; the second from 1914 to the Armistice period in 1918; the third from 1918 onwards, the opening of the period of reconstruction and reaction. The first period, from 1910 to 1914, was marked by the steady progress of the new order. The sectarian controversy which had raged round the Act of 1902 had subsided; a wider and deeper conception of educational relationships was growing steadily with a more general acknowledgment of the truth, that national education in England must combine a wide variety of opinions and a large freedom of curriculum. There was a new spirit of tolerance. The administrative authorities, central and local, had set themselves seriously to carry forward the extension upwards of the educational structure on the basis of the 1902 settlement. These are years of steady progress and widening outlook.

The second period is that of four years of war, a period in which there was much less check to the continuous work of school education than might have been expected. But necessarily the schools suffered by reason of the war. The young male teachers went off on service, many school buildings were required for military and emergency purposes, the restrictions as to the employment of children were relaxed. Yet the war gave a new impulse to school life. Examples of service and sacrifice were present to the mind. There was a strain and seriousness which affected both teachers and scholars, and gradually, too, there came to the nation a fresh realization of the value of education in developing individual and national life. Already in the early years of the war expression was given to the demand for a wider and fuller system of national education, and steps were taken for the systematic consideration of the problem of "continuation education" and later of "adult education." Before the conclusion of hostilities the Departmental Committee on "Juvenile Education in Relation to Employment after the War" had presented its report and the Minister for Education had framed, and Parliament approved, a measure which ranks with the great Acts of 1870 and 1902. Moreover the army itself had become a great school or university and the experiments carried out with the forces at home and overseas in adult education were fruitful in stimulating new ideas as regards the scope and method of national education and in directing attention to the place which education should have in the life of men engaged in the military and naval services.

The third period from the Armistice onwards, presents, in less than three years, marked contrasts. In the first enthusiasm for reconstruction there was a vigorous forward movement with the view of bringing into operation as rapidly as possible the provisions of the 1918 Acts. It was more than a period of reconstruction; it was a time of new national ideals. Then came the ebb, with economic pressure, industrial unrest, high costs of construction and equipment, and financial stringency, and the larger educational programme has been temporarily suspended. In the grey morning of reparation and economic reconstruction after a World War education had suffered, and there was some receding of the high hopes and feelings. But the check could only be regarded as temporary, and the ideas born in war and in the early days of peace were in 1921 already reasserting themselves.

In considering the period from 1910 onwards it must also be borne in mind that the educational movement has been increasingly closely interwoven with other developments. Thus the public library organization in the years immediately preceding the war was being linked more closely than before with the educational system. It must also be remembered that already before the war a stronger national spirit had been evincing itself in education in the several parts of the United Kingdom. England, Wales, Scotland, Ireland, each was shaping on its own lines its national system, and the comparison of the development in the several states is rich in instruction for the student of mod-

ern education. But while there has been an increasing measure of administrative devolution in education the main lines of progress are common to all parts of Great Britain, though to a less extent to Ireland. England, which had been in the past more backward in its general education provision of elementary and secondary education than Scotland or Wales, has perhaps shown a greater advance during these years than any other part of the United Kingdom, and has not only led the movement for an obligatory system of continuation education to the age of 18, but has opened a wider vision of adult civic education and culture.

*Education in England.*—When the position of education in England was reviewed at the opening of the second decade of the 20th century, it could be seen that the system established by the Act of 1902 had become firmly established. That Act had done three noteworthy things. First, it had abolished the school boards and transferred their powers as regards education to the county and municipal councils. Secondly, it brought the voluntary elementary schools under the local education authority and assisted them by support from local rates, while leaving them a large measure of control in management. Thirdly, it had given the new local education authorities power to provide for schemes of secondary education and to levy rates for this purpose. Since 1902 there had been no important change in the constitutional machinery of the educational system in England. The Act of 1918 in England called into being no new order of local education authorities, as had been done by the corresponding Act in Scotland. In 1921 there were in England nearly three hundred local education authorities, with powers of making schemes and levying rates, standing in direct relation to the Board of Education, whereas in Scotland the number of local education authorities had by the Education Act (Scotland), 1918, been reduced to under 40. The consolidating movement had, therefore, progressed much further in Scotland than in England.

As regards elementary education, already in 1910 the system in England had become well established. Attendance at school was required up to the age of 13, and by the Act of 1918 is obligatory on all up to the age of 14. The average attendance has varied from 86% to 89%. Apart from the abnormal period of the war there has been a gradual diminution in granting of exemptions from school, and the Act of 1918 abolishes whole or partial exemption under 14 years. There has been little change in the number of public elementary schools in England. In 1903 there were 18,487, and in 1910-20 their number was 19,070. But there has been a considerable change since the Act of 1902 in the number of council and voluntary schools respectively. Since 1903 the number of voluntary schools has fallen from 13,438 to 11,635, whereas the council schools have increased in number from 5,049 to 7,435 in 1920. The total average attendance of pupils in public elementary schools in England, in 1920, was 4,795,672. In respect of the provision of teachers the period also shows relatively little change, but gradual improvement. The number of teachers, per 1,000 pupils in average attendance, in 1910-11, was 30.9, of whom 19.01 were certificated, 8.10 were uncertificated, and 2.98 other adult teachers. In 1919-20 the number of teachers per 1,000 scholars was 30.4, of whom 21.8 were certificated, 6.3 uncertificated, and 2.3 other adult teachers. In certain other matters, however, there had been very marked advance. In the years 1907-10 steps had been taken to secure to the local education authorities in England and Wales powers to establish medical inspection, to provide meals for school children where this was considered desirable, and to organize information in co-operation with the labour exchanges for the guidance of children in the choice of employment on leaving school. Provision had also been extended for the purpose of dealing with the mentally and physically deficient and a much wider recognition was secured for "after care" work among school children. A wider conception of the school and its responsibilities was thus steadily emerging. The Act of 1918 has carried the movement forward and has converted these powers of local education authorities into a duty to look after the health and physical condition of the children in public elementary schools. A system of school health services providing not only medical inspection, but

also treatment, is now well on the road to accomplishment. Again, as regards the physically and mentally defective and epileptic children, the Act of 1918 requires that the local education authorities shall ascertain what children in their areas are thus afflicted and shall make provision for their education. It is also worthy of note that the Act of 1918 lays particular emphasis on the great importance of healthy recreation. The Act enables local education authorities, with the approval of the Board of Education, to supply, or maintain, or aid (a) holiday or school camps—especially for young persons attending continuation schools, (b) centres and equipment for physical training, playing fields, school swimming-baths, (c) other facilities for social and physical training in the day and evening. A very large proportion of the proposals already submitted have been concerned with holiday and school camps. In this connexion it may be noted that the 1918 Act specially encourages local education authorities to avail themselves of voluntary services, particularly in the development of the recreative side of school life, and the work of the Juvenile Organizations Committee in promoting healthy recreation is a sign of the new spirit which is now steadily pervading the educational system. Thus with the great development in State action, the sphere of voluntary action is also increasing. The ideal education policy requires voluntary and state agencies acting in close co-operation.

Secondary education in England presents a very different situation. It might almost be said that, until the opening of the 20th century, there was no national system of secondary education in England. The number of secondary schools, apart from the residential public schools and the old grammar schools, were few and the gateway from the elementary schools was very narrow. But the Report of the Royal Commission on Secondary Education in 1895, the Education Act of 1902, and the Regulations for Secondary Education in 1907, are stages in the foundation work of a new order, and during 1910-20 considerable progress was achieved in building up the framework of a national system of secondary education. The great public schools and grammar schools which have been so distinguished a feature of English higher education retain their independence and their well-deserved prestige. Like the ancient residential universities of Oxford and Cambridge, their position has been strengthened rather than weakened by the growth of new institutions. But the public schools (as the term is understood in England, meaning Eton, Harrow, and so forth) can only supply education to a very limited number and at a high cost, while there is a steadily increasing demand that there shall be easy provision of secondary education for all children who are willing and able to avail themselves of it. By 1911 there were 862 secondary schools on the Board of Education grant list, with 141,000 pupils; in 1920 there were 1,021 schools, with 282,005 pupils. There were also in 1911 96 secondary schools recognized as efficient but not on the grant-earning list, with over 17,000 pupils—while in 1920 there were 201 of these schools with 36,271 pupils. In the case of the schools on the grant list normally 25% of the places must be free; the actual proportion was considerably higher.

In considering however such figures of secondary education a caution is necessary. By far the greater number of pupils attending these schools are under 16 years of age. In the season 1919-20, out of the total of 282,005 pupils in the secondary schools 13,386 were under 12 years of age, 177,988 were of 12 and under 16 years, while only 20,631 were 16 years of age and over. Thus for all except a very small percentage, secondary education ends before 16 years of age. When it is recalled that there are close on 5 million children in the public elementary schools of England, and that the number leaving the elementary schools each year must be close on 600,000, it is evident how restricted the national provision of secondary education still remains. This in itself emphasizes the importance of the step taken in 1918 to provide obligatory continuation education. It is the case that in England the demand for secondary education has considerably exceeded the supply, but it is also true that the pressure of economic circumstances and the tradition of getting to work early will prevent a very large number of children in the elementary schools from

continuing or desiring to continue as full-time secondary school pupils. For the immediate future, therefore, a general system of continuation schools is the best hope of imparting the benefits of higher education to the majority of young people.

Already for many years local education authorities have been providing increased facilities for evening students—especially in technical and manual instruction. The circumstances of the war, however, stimulated greatly the public sense of the value of a much more complete system of continuation education, and brought into relief the defects of this side of educational organization when compared with the system of continuation education in Germany. Accordingly in 1916 the Minister of Education (Mr. Arthur Henderson) appointed a Departmental Committee on Juvenile Education in relation to Employment after the War. This committee submitted in its final report, in 1917, recommendations which the then Minister of Education (Mr. H. A. L. Fisher) largely embodied in a bill. Modified in certain particulars, this bill became the Education Act of 1918.

The Education Act of 1918 is, however, much more than a measure establishing an obligatory system of continuation education. It affects the whole scheme of elementary, secondary, and continuation education. It aims at the establishment of a "national system of public education available for all persons capable of profiting thereby," and local education authorities have, under the first section of the Act, been called upon to prepare schemes setting out the provisions which they have made and propose to make towards this great end. The Act makes important specific changes in respect of elementary education, including the provision of "nursery" schools for children between 2 and 5 years, the raising of the compulsory school age to 14, with power to the local education authority, by by-law, to extend the compulsory age to 15, the abolition of part-time attendance, the provision of central schools and special classes of more advanced and more practical instruction for the older and more intelligent children in the elementary schools, and it emphasizes the social welfare side of education.

In respect of secondary education, the Act requires local education authorities to cooperate in providing for the purposes of Part 2 of the Education Act of 1902 (*i.e.* higher education), particularly in respect of (1) the preparation of children for further education in schools other than elementary, and their transference at suitable ages to such schools, and (2) the supply and training of teachers. Also the very important duties and powers with reference to provision for medical inspection and treatment of children in elementary schools are extended by the Act to secondary and continuation schools. The Act removes the limitation, under section 2 of the Education Act of 1902, on the amount to be raised by the council of a county out of rates for the purpose of education other than elementary. The Act of 1918 is thus built on the foundations of the Act of 1902 and does much to complete the educational ladder.

But important as are these provisions, the main feature of the Act of 1918 is the institution of a compulsory system of part-time continuation education after the close of the elementary school period. "Young persons," between the ages of 14 and 18, are required to attend a continuation school for 320 hours a year—unless able to claim exemption under the Act. This is the cardinal fact of the new Act. For the first period of seven years compulsory attendance applies only to pupils between the ages of 14 and 16 years and a local education committee may reduce the number of hours' attendance to 280—modifications which give time to the authorities to make provision of schools and teachers where-with to meet the new situation. Owing, however, to contingencies, mainly financial, the operations of the Act have to a considerable extent been postponed. But these difficulties are temporary, and the experience of a national system of part-time work and part-time education will presently begin to furnish instructive evidence on the value of secondary education and continuation education respectively. It is a matter which merits the most careful observation in the next period.

In connexion with this very important subject it should be stated that in the session 1918-9, 125,000 students were in

attendance at technical and special schools in England, while the number attending evening schools, chiefly under the local education authorities, exceeded 465,000. Attention should also be directed to the very notable and encouraging growth of classes under the Workers' Educational Association and the university tutorial classes. England has been the home of this development, which is one of the most significant and encouraging signs of the times. In 1918-9 there were 87 one-year classes organized by the Workers' Educational Association and 132 tutorial classes which are three-year courses. In 1919-20, the number of one-year courses had increased to 159 and of three-year courses to 182. These classes have been concerned mainly with economic history and theory, political and social science, history, literature, and in some cases philosophy. Summer schools are now held at many of the universities, for students from the tutorial classes. The growth of the movement opens out a new vista for democratic education in and from England.

*Education in Wales.*—In considering the development of education in Wales, it will be remembered that while English and Welsh education have been under one Ministry there has been a growing movement towards Welsh autonomy in education. In 1889 Parliament passed the Welsh Intermediate Education Act which provided for separate local committees to make provision for secondary education in Wales. In 1896 the Welsh Central Board was established—a representative body with the duty of inspecting and examining the intermediate schools. In 1907 there was constituted a separate Welsh department within the Board of Education, with a permanent secretary and a separate inspectorate for Wales. But the great educational Acts of 1902 and 1918, together with minor educational measures, have in the main applied alike to England and Wales. Thus in Wales the system of elementary education broadly corresponds to that in England. In 1920 the number of elementary schools was 1,907, of which 1,270 were council schools and 637 voluntary schools. Education is compulsory up to 14 years of age, and in 1919 the average attendance out of a total of approximately 464,000 scholars on the register was 389,000.

The position as regards secondary education deserves more particular notice. There are three groups of secondary schools in Wales which are on the grant-earning list or are recognized by the Board of Education as efficient. The first and largest group is that of the intermediate schools numbering 101 in 1920. They are examined and inspected by the Welsh Central Board, but they are also reported upon and certified by the Board of Education in respect of qualification for the Treasury Grant. Secondly, under the Act of 1902 the local education authorities have established, particularly in the large centres of population, 12 secondary schools, which are not under the Welsh Central Board but are examined and inspected by the Board of Education. Thirdly, there are a few endowed schools, six of which in 1920 were on the grant-earning list and five were recognized by the Board of Education as "efficient." The total number of schools, intermediate and secondary, eligible for grants in Wales in 1919-20, was thus 119, and the number of pupils 25,754, while in the five efficient schools, not on the grant-earning list, there were 788 pupils—the total number of pupils in secondary schools recognized by the Board of Education being 26,542. Thus the situation with regard to secondary education has been complicated in Wales and has suffered from dualism of control. The constitutional powers of the Welsh Central Board have not been such as enabled it easily to make provision for the increasing demand for secondary education and recourse has been necessary to the municipal and county authorities established under the 1902 Education Act. Accordingly in 1919 a committee was appointed by the Board of Education "to inquire into the organization of secondary education in Wales and to advise how it can be consolidated and co-ordinated with other branches of education with a view to the establishment of a national system of public education in Wales—regard being had to the provisions of the Education Act of 1918 and to the recommendations of the Royal Commission on University Education in Wales." In their report this committee, while recognizing the valuable work

achieved by the Welsh Central Board, drew attention to the fact that the system of secondary education as it has developed in Wales has, owing to the division of authority, provided an organization which "is less elastic and less adaptable than that of England to the new demands likely to be made upon it by the Act of 1918." They therefore recommend that the Welsh Intermediate Act, which being a "temporary" act has been periodically renewed, should be allowed to lapse, and that the intermediate schools and the municipal secondary schools should be brought under one local county education authority which should make provision for a completely co-ordinated scheme of secondary education within its area, and that a National Council of Education for Wales, representative chiefly of the Welsh universities and of the education authorities in Wales, should be set up under the Ministry of Education to which wide powers should be devolved in relation to the whole field of education, elementary, secondary and university. The aim is thus to provide in Wales a national educational authority more complete in its scope, and more representative in its constitution, than exists at present in any part of the United Kingdom. Meanwhile, as in England and in Scotland, there has been in Wales, especially since the war, a marked increase in the demand for higher education. The proportion of scholars who pass from the elementary to the secondary schools has, in nine years, risen from 55% to 53%. The further problem of the relation between the secondary schools and the university of Wales has received particular attention from the Royal Commission on University Education in Wales, and a scheme has been recommended whereby the county authorities shall assume greater responsibilities towards and receive increased representation in the National University, so that elementary, secondary and university education may be three closely related parts of one common system. The object in view is that no child on the ground of lack of means may be debarred from receiving the very highest education the nation can supply. Wales is thus in a most interesting and progressive stage of development towards a complete national scheme of democratic education. The growth of Welsh education is reflected in the great increase in the estimates of educational expenditure. In the year 1921-2 the estimates of net expenditure on elementary education in Wales amount to £4,999,804, while the estimates for higher education are stated at £846,716. Thus in Wales, elementary and secondary including continuation education already claim £5,845,000. So also in England the latest corresponding estimates (1921-2) provide for a net expenditure of £38,648,016 on elementary education and of £12,622,015 on higher education—the total figures for elementary education thus exceeding 71 millions. When it is remembered that considerably increased sums will be required for continuation education, and for further extension of university education, it will be seen how great and growing is the recognition of the service of education in England and Wales.

*Education in Scotland.*—The progress of education in Scotland in the period 1910-20 is in many respects similar to that which has been seen in England and in Wales. There was no Act for Scotland corresponding to the English Act of 1902, because conditions were different and at that time, as now, the local education authorities in Scotland were considerably in advance of those in England particularly as regards aiding, maintaining, and controlling secondary education. Scotland also did not follow the example of England by transferring the control of education from the school boards to her county and municipal councils. But at the close of 1908 the Education (Scotland) Act was passed, which can properly be regarded as marking an important stage in the development of Scottish education. For while it made no fundamental change in the educational system of Scotland the Act enlarged the powers and duties of local education authorities, and laid the foundations for the even greater Act of 1918.

In the history of education in Scotland, more than in any other part of the United Kingdom, there may be seen a steady direction of the national system along clearly marked lines, and the Act of 1908 and, later, that of 1918 illustrate this character. First, the idea of separate local educational authorities has been

maintained and Scottish education thus continues to present an interesting comparison with the system in England established since 1902. But while the school board system was maintained in Scotland until 1918 the need of larger areas has steadily made itself felt, and in the Act of 1908 powers were given to school boards to combine for various purposes. This immediately took effect and in the report of the Scottish Education Department for the year 1910-2 it is stated that 13 unions of school boards have already been effected by voluntary arrangement, or by order of the Department. It was pointed out, however, in the same report that it was doubtful whether this policy of combination of school board areas could be carried very far, and that, however active individual school boards might be within their own areas, it was clear that there are educational functions which transcend the sphere of the ordinary school board. This is particularly the case in respect of secondary education, where in effective work authorities controlling wider areas are necessary. The Act of 1918 carries out the work of enlarging areas and consolidating local organization, which had been, thus tentatively advanced by the earlier Act of 1908. Secondly, as in England and Wales, there has been a continuous movement of transferring voluntary schools to the control of the statutory local education authorities. Such schools have not been so many or so important in Scotland as in England, but there has been a growing appreciation of the value of a national system which leaves room for variety of type and which recognizes the place of the denominational school within the national system. The Act of 1908 assisted the transfer of voluntary schools to the school boards, and the completion of this movement has been secured under the Act of 1918. Thirdly, there has been a steadily widening conception of the educational duties of local authorities. The Act of 1918 enabled school boards to make provision, either by themselves or in combination with other school boards, for the supply of meals to pupils attending school within their district, to provide conveyance and travelling expenses in order to help children in outlying districts to attend school, to extend information as to employment open to children on leaving school, and to make provision for the maintenance and education of physically or mentally defective children. It gave powers also to school boards to secure medical inspection and supervision of children attending school. A special Act of 1913 added medical treatment to medical inspection, and the Act of 1918 made such duties obligatory on the local education authorities. Fourthly, there has been a consistent policy of building up a complete national system, not only of primary and secondary education but of continuation education, and of increased facilities of university or other specialized higher training. The Act of 1908 made important provision for the extension of the system of continuation schools above the age of 14 years, requiring school boards to make suitable provision for such schools, and it thus prepared the way for a universal system of continuation education.

In two other respects also the Act of 1908 made a notable contribution to the better organization of Scottish education. It made provision for a national system of pensions and superannuation of teachers, and it consolidated and simplified the financial arrangements for the control and distribution of State grants by the constitution of the Education (Scotland) Fund.

The Education (Scotland) Act, 1918, which in many respects corresponds to the Education Act for England and Wales of the same year, may be regarded as the most important measure relating to education in Scotland since 1870. In one sense the Act only carries out developments which had been making themselves evident even before and especially after 1908. But the new stage marks the transition from tentative and partial efforts to that in which a wider envisagement of the whole field of national education is realized. A new order of local education authorities is called into being, in order to carry forward the work of developing the larger policy. In place of the 945 school boards and 38 secondary education committees, 38 local education authorities have been established, elected under the system of proportional representation, known as the transferable vote. To these local and county education authorities are

committed the powers of determining and controlling the whole system of primary, secondary and continuation education within their respective areas. To aid them in their work a system of school district management committees has been provided, each county being left to determine the number of such committees within its area. At the same time a representative National Council for Education has been constituted under the Act with the view of advising the Scottish Department of Education—an important step in bringing the central administrative organization into more direct touch with a representative body. Locally, also, provision has been made for the establishment of advisory councils, which may stimulate on the one hand public opinion and on the other assist the local education authorities on special questions, particularly such as relate to economic and industrial conditions. The value of such local councils has yet to be proved, but the step taken is significant of the desire to bring the administrative system both centrally and locally as closely as possible into touch with public opinion. In considering the great change which the Act of 1918 has made in the representative machinery of Scottish education, it may be well to point out that the working of the new machinery of government will demand close attention. It is permissible to doubt whether the Act has not gone too far in abolishing the local school boards and in constituting in their place county authorities with school management committees, which latter bodies frequently are concerned with an area larger than that of the former school board. The school management committees are selected in a variety of ways, but they do not have behind them the simple strength and influence of popular election. The measure of the success or failure of this step will be found in the extent to which local interest in educational matters is sustained or weakened. That statutory bodies, exercising wide powers and controlling larger areas, were necessary does not admit of doubt, but the sweeping away of the local school boards may be found to have removed the most effective agency of stimulating local interest in education. The problem of securing the best form of representative machinery to deal with modern educational problems is a matter of very great importance, and its solution is yet by no means reached. For that reason the variety of experience presented in the United Kingdom is of peculiar interest. It may be added that, at the election for the new local education authorities in Scotland under the Act of 1918, only some 30% of the electorate recorded their votes. This in itself is a significant and disappointing fact, and indicates the need, even in Scotland, of stimulating local interest in education. Another important constitutional aspect of the Act of 1918 was the change made in respect of financial administration. The Education (Scotland) Fund, as established under the Act of 1908, is by the Act of 1918 so regulated that the distribution of grants will give to the local education authorities greater discretion and flexibility in the expenditure of the moneys entrusted to them by Parliament. Instead of earmarking particular grants for particular services, the earning powers and claims of the local education authority as a whole are assessed by the Department of Education, and great latitude is allowed to the authorities in the disbursements of the sums, provision, however, being required for the maintenance of secondary education. There has resulted thereby a simplification of finance and an increase in the responsibilities of local education authorities. Apart from these important changes in the representative system and in financial administration the chief features of the Act are the raising of the full-time school age to 15 years and the requirement of obligatory continuation education up to 18 years of age. For the period of three years from the passing of this Act, the compulsory age for continuation education is limited to 16 years, whereas in England seven years elapse before the full policy of the Act can take place. The 1918 Act carried out to its logical conclusion a development which had been steadily advancing for many years throughout Scotland. Under the Act of 1908 it was lawful for school boards with the consent of the Scottish Department to make a by-law, requiring attendance up to the age of 16 at continuation classes. Already in the session of 1913-14, before the war interrupted normal devel-

opment, 18 school boards in Scotland had availed themselves of this power, and in the Education Report for the year it is observed "that the need is apparent, after a lapse of five years since the Act of 1908 came into force, for more vigorous steps to be taken to interest and make more effective the provision of continuation class instruction particularly in the rural districts," and it is pointed out that compulsory methods have stood the test well in the few districts where by-laws have been made.

The educational ladder in Scotland is now strongly established. There is an excellent system of primary education for children to the age of 14, and powers have been taken to raise the compulsory age to 15, while for those who have the ability to profit, and the desire to do so, there is a generous system of bursaries and maintenance grants from the elementary to the higher grade and secondary schools. It is claimed that any child of ability can now obtain higher education and in turn secure the further opportunity of a college and university education. In 1920 there were 3,019 primary schools in Scotland, with effective accommodation for 947,125 scholars, 104 intermediate schools or departments with accommodation for 26,420 scholars, 148 secondary schools or departments and 134 preparatory departments; of secondary schools with total accommodation (including that of the preparatory departments) for 208,085 scholars, and 53 special schools for blind, deaf, mute or defective and epileptic children, having accommodation for 6,658 scholars. The total number of scholars in the register at the end of the school year 1919-20 was in primary schools (or departments) 769,243; intermediate schools (or departments) 11,909; preparatory departments of secondary schools 49,259; secondary schools or departments 44,095; special schools and classes 7,266—making a total of 872,772 scholars on a total estimated population of just over five millions. If the table of ages of scholars is examined it appears that rather more than a total of 20,000 pupils of 15 years of age or over were enrolled in the session 1919-20 in these various classes of schools. The proportion of secondary scholars to population is, higher than in any other part of the United Kingdom, but it indicates how limited still is the number who, even in Scotland, receive full-time education beyond the age of fifteen. But there has been a steady increase in the total number of pupils attending intermediate or secondary departments. Even in the period of 1913-4 to 1918-9 the number of pupils enrolled in these schools rose from 47,722 to 58,948, and in the year 1919-20 the rate of increase has been fully maintained. As regards continuation classes the number of these in the session 1919-20 was 1,083, with 166,463 students. A feature, particularly of the last sessions, has been the development in Scotland as in England of classes organized by the Workers' Educational Association for adult pupils. As regards financial provisions, the income of the education authorities under the Scottish Education Department was for the year ending May 15, 1920 £9,649,430, in this total the chief items of interest, being grants from the Scottish Education Department £5,409,078, local education rates £3,072,531, school fees £119,046. Great as have been these advances in the sphere of education there remains one matter which is always of the highest concern, namely, the training and provision of teachers. Powers may be extended and equipment improved, but the most vital problem is the supply of teachers and of the spirit in which they carry out their work. In the past in Scotland, the teachers' training colleges owed their foundation to provision made by the churches. The training colleges have gradually shed their denominational character, and in 1905 they passed under national and undenominational control. There has been a steady requirement of a higher standard of training and, to-day, practically all teachers in Scottish schools under the Department of Education are certificated. In 1919 the number of fully qualified teachers in State-aided day schools was 24,782; the proportion of teachers to pupils being in primary and intermediate schools 1 to 37, in secondary schools 1 to 23, and in schools and classes for blind, deaf, mute, defective and epileptic children 1 to 17. A particularly satisfactory feature is that, despite the losses and difficulties of recent years, the proportion of teachers to pupils is considerably higher in 1920 than in 1914.



1913-4. The Scottish educational system is thus, to-day, strong and progressive and it maintains its distinctive independence. But it is a striking evidence of the way in which autonomy tends to follow similar lines of development, that at no time has there been so much in common between English, Welsh and Scottish education as at the present day. Left free, each system develops its own peculiar spirit and traditions, but it also tends to assimilate itself to the standard of other progressive systems.

*Education in Ireland.*—The system of education in Ireland has undergone no such marked development as was seen in England and in Scotland during the years 1910-20. Educational progress in one part of the United Kingdom must always affect the other parts to some extent, and steps have been taken in Ireland as in other parts of the United Kingdom to make better provision for medical inspection, for the care of physically and mentally defective children, and for attending to the feeding of school children. But the condition of affairs has remained far from satisfactory in both primary and secondary education, and this is even more the case as regards continuation education.

In Ireland the control of education is divided between three public departments. The Commissioners of National Education deal with primary education, the Intermediate Board with secondary education, and the Department of Agriculture and Technical Instruction, with agricultural and technical education. To a limited extent coordination is secured between the several departments, and the Consultative Committee of Education, on which all three departments are represented, is an evidence of this. But the autonomy of the several departments remains the outstanding fact. Education undoubtedly suffers from this division of control, and from time to time the question has been considered of uniting the various boards of educational administration in one system. In Nov. 1919 a comprehensive Education (Ireland) Bill was introduced by the Chief Secretary for Ireland, which among other things proposed to set up a single Department of Education in Ireland, but it failed to become law. In the past the educational problem has been constantly overshadowed by political considerations and no effective step has yet been made towards that unity of direction and completeness of supervision which can only be secured either by a single department or by the closest cooperation and harmony between the separate departments. The difficulties and disabilities arising out of division are further accentuated by the widely different systems represented by the three boards. The Commissioners of National Education who are responsible for the position of primary education in Ireland, and who, therefore, have by far the greatest task placed upon them, represent a centralized and bureaucratic system of administration such as cannot be paralleled in any other part of the United Kingdom. As primary and secondary education are not matters which have been handed over, as in England and Wales, to the local county and municipal authorities or to local education *ad hoc* authorities as in Scotland, the only local control rests with the school management of the individual school and the local attendance committees. It follows, so far as primary and intermediate or secondary education are concerned, that there are no local rates. The financial resources required for this most important part of national education have, therefore, to depend upon moneys voted by Parliament, or upon the yield of endowments, contributions, and school fees. The result of this is that, so far as primary and intermediate education in Ireland are concerned, the financial position is most unsatisfactory. The resources for the maintenance, and still more for the improvement, of national education are very inadequate, and the old order has continued to exist at a time when great measures of educational advancement are being carried out in the other parts of the United Kingdom. The day has passed when grants from a central department, supplemented by voluntary contributions, can be equal to the burden of a national system of education, and Ireland is constantly suffering from the fact that she has not faced the responsibility of establishing a system of local education authorities, and of charging the local rates with a share of the burden of primary and intermediate education. The problem in Ireland is complicated by

the denominational character of the schools and by the strong element of clerical control in local educational matters. But, if education is to advance, local and lay control must share the burden of responsibility, and developments in England, Wales and Scotland prove that alike the central Department of Administration and the local authorities can find a place in the national system for denominational schools. Until the people of Ireland locally and directly show their zeal for education by securing the establishment of local educational authorities with powers to rate, Irish elementary and secondary education cannot keep pace with the progress which is being made in the sister countries. The question is so fundamental that it must always be in view, as during the past ten years the difficulties inherent in the present system of primary and secondary education have been making themselves increasingly felt. In 1913 a Viceregal Committee of Inquiry into Primary Education was appointed to report upon the system of inspection of primary schools, the relations between teachers and inspectors, and the system of promotion of teachers in national schools, and both the evidence and the report illustrate how difficult is the problem of encouraging and remunerating teachers, and of giving scope for educational development where there are no local representative authorities and where promotion depends upon the report of inspectors and the decision of the National Board. Alike in Scotland, England, and Wales experience has proved how necessary it is to have wide areas and to link education closely with the interests of the community. In Irish primary education, the absence of local representative authorities controlling large areas with a wide range of schools accounts for much of the present stagnation of education, and places upon the Central National Board the increasingly invidious task of a bureaucratic system. Nor can it be said that there is any effective parliamentary control over Irish primary education. The system is thus constitutionally weak and fails to stimulate alike local interest and national public opinion in the vital question of education.

What is true of primary education in Ireland is also true in respect of intermediate education, though owing to the much more limited number of schools the problem is less acute. One of the most serious aspects, however, of Irish education remains the very inadequate provision which is made for secondary education, other than agricultural and technical education. The supply of schools, and the financial provisions for such as exist, fall far short of what modern Ireland should have. In Ireland, as in Great Britain, there is an increasing demand for higher education and with the change in the value of money the situation of the secondary schools is especially precarious. In their report for the year 1920 the Intermediate Education Board commented severely on the fact that the grants in aid of Irish secondary education from the Treasury are considerably less than the proper share which should have been allocated for this purpose when compared with the grants in England, Wales, and Scotland, and they conclude their report with the grave words " . . . remembering also the scanty funds with which our admittedly successful efforts were achieved, it is difficult for us at this juncture—when the whole edifice of secondary education in Ireland is toppling to destruction—to refer to these matters in language of moderation and restraint. Of one thing, however, we feel quite certain, and that is, that if something is not done immediately to place Irish secondary education in the position of financial equality with that of Great Britain, it is impossible to see how the complete disruption of the system can be avoided." In one respect improvement has been made in recent years in the work of the Intermediate Education Board, by the belated establishment of a system of local inspection. The Intermediate Board system has been in the past too much a central examining body rather than an educational department, and even with the limited step which has now been taken to secure supervision of the intermediate schools and their work by the board's inspectors, control is largely exercised through the medium of written examinations. Thus both in respect of primary and intermediate education, Ireland has presented a very unprogressive form of organization and even with the improvements made in recent years, the system remains very

far from satisfactory. There is no part of Irish public administration in which reconstruction is more vital or more urgent. According to the Commissioners of National Education in 1918-9, the average number of pupils on the rolls of the 8,802 primary schools in Ireland was 708,353, and the average attendance 488,031—or 68.9%. The highest average yearly attendance in the past ten years has been 72.6 per cent. These figures are in themselves eloquent as to the very backward state of Irish primary education. The State expenditure on Irish primary education amounted in 1918-9 to £2,375,362. In respect of secondary education, 386 schools in Ireland received grants under the Intermediate Education Board in 1920, the total number of pupils between 12 and 19 years of age in these schools being 87,250. The number of pupils between the ages of 14 and 19 years, who presented themselves for examination under the Intermediate Board, was 11,948, of whom 6,002 passed. The grants to intermediate or secondary schools from the statutory funds and the parliamentary grants of the Intermediate Board amounted in 1920 to rather less than £142,000.

The third department responsible for a part of Irish education is the Department of Agriculture and Technical Instruction, and at least in this field of agricultural and technical instruction Ireland can claim to have a system which is worthy of comparison with that of any modern state. The importance of the system established in respect of agriculture and technical instruction lies not simply in the merit of the education provided in the schools and colleges under the Department's supervision, but in the improved representative relationships between central and local authorities provided by the constitution of the Department, The Agriculture and Technical Instruction Ireland Act of 1899 provided for the appointment of local statutory committees of the county councils and municipal councils of Ireland to deal with the subjects of agriculture and technical instruction, including the raising of local rates for these purposes. It also brought about the establishment of a central Council of Agriculture, consisting in respect of two-thirds of its membership of representatives of county councils, the remaining third being nominated by the Department. At the same time provision was made for the appointment of a Board of Agriculture chosen in respect of two-thirds of its membership from the Council of Agriculture, the remaining third being nominated by the Department, and of a Board of Technical Instruction representing chiefly municipal and borough authorities concerned in technical education. Important functions and powers were given to these bodies of shaping the policy and the administration of the Central Department. The result of this representative machinery has been a closer harmony between central and local authorities than has been secured in any other field of public administration in the United Kingdom, and the great progress which has been made in Ireland in the two decades of the 20th century, both in agricultural education and technical instruction is in no small measure due to the admirable constitutional organization which was laid by the founders of the Department. The close relationships between central and local authorities have, even in a difficult period of national affairs, led to increased interest in the progress both of agriculture and of technical instruction, and no part of government in Ireland has succeeded in so fully associating the people with the work of administration and in educating public opinion and eliciting local financial support. The work which thus centres round the Irish Department of Agriculture and Technical Instruction has exercised a great influence on modern Ireland. It has given a much needed impetus and direction to science teaching and research, to agricultural study and investigation, to manual training and craftsmanship, to commercial and industrial subjects in relation to the economic conditions of the country and to domestic economy and public health education—all of which are peculiarly vital to a community in which education has suffered from a too narrow and bare curriculum. But it has done more, and has suggested, by experience, the possibilities of a much wider reestablishment of Irish education in which all parts will be brought into closer relation one with the other and strengthened by association with central and local

representative committees. In the year 1918-9 the grants made out of the parliamentary vote to technical schools and classes of science and art amounted to £114,210—while a further expenditure on technical instruction, amounting to £65,867, was made out of endowment funds. In addition to these sums the sum contributed from local rates amounted to £36,518. The number of students attending technical schools and classes was 37,241, and the number of students recognized for grants in connexion with technical instruction in day secondary schools was 14,822.

*Conclusion.*—Looking back over the period from 1910-20 and across at the varied developments in the countries which make up the United Kingdom, the year 1918 stands out as summing up the effort of the preceding years and projecting the task which succeeding years have to fulfil. Nineteen-eighteen is the symbolic year, and the place which education then filled in the thought of the nation is itself a revealing fact. There has been a great widening of the horizon. The school now goes down to the nursery school, and the leaving age rises. The defective children are being treated, and the child life of the nation is its care. Slowly but surely a national system in the full sense is evolving in England and in Wales, no less than in Scotland. Ireland still has to solve her educational problems and must do so in her own way and by her own genius.

The great task is now the building up of higher education on lines which call out and use the talent and spirit of the nation. The problems are vastly more complex and difficult than those of primary education. But they are being solved, and increasingly generous financial provision for education is forthcoming. The education estimates already bid fair to rival the place which the naval and military estimates have taken, and before long it may prove true that in no field of public expenditure has the State to shoulder so large a responsibility as in education. But education is not only a means but an end. And a Nation like an individual has to work and save in order that it may enjoy the fullest education. One can discern the coming of this spirit in England, and it is a sign of hope for the future. Nothing but a united community and the combined strength and experience of central and of local authorities, of state and of voluntary organizations, can provide a solution to the problems which the higher education of youth and adult life has in store. Nor must it be forgotten that social institutions are a great factor in national education. The Boy Scouts, and Girl Guides, the Women's Institutes, the village clubs, the allotments movement, the cooperative societies, these and many other voluntary agencies are growingly powerful factors in national development and education. And judged by the progress of such movements, the second decade of the 20th century and the closing years of that decade will stand out in the annals of English education. (W. G. S. A.)

### (2) UNITED STATES

Each state in the American Union has its own system of education, which includes elementary and secondary schools, and, in all except the states of the extreme north-east, state institutions of higher learning. All of the 48 states have enacted compulsory school laws, but in their standards, and in the enforcement of them, they vary widely. School attendance in 1922 generally required of children between the ages of 8 and 14 or 16 during from 6 to 8 months in the year, and many states further require attendance upon part-time or evening classes by those who have not acquired a prescribed minimum of education or who can not adequately speak, read and write the English language. The National Government, through Congress in 1916, notably reinforced the compulsory school laws of the states by an enactment prohibiting the shipment, in interstate commerce, of any articles in the manufacture of which children under 14 have been employed. In place of the almost universal requirement of eight years in the elementary school and a nearly uniform curriculum, there is manifest a tendency to group together as a "junior high school" the seventh, eighth and ninth grades, which otherwise would constitute the last two years of the elementary school and the first year of the secondary school. The purpose of the re-arrangement is to facilitate departmental teaching, to free the

child from the rigid grade system of promotion, by which a failure in one subject necessitates the repetition of the whole year's work, to permit earlier a choice of courses and thereby prepare the pupil for greater accomplishment in his chosen field during the later high-school years. The public secondary schools have grown by leaps and bounds in numbers and resources. Their enrolment doubled in the 20 years 1908-18 and between the years 1918 and 1920 there was a proportionate increase. They are no longer essentially stepping stones to college; they represent the continuation of the common schools, and their function is to complete the formal education of that vast majority which will never enter institutions of higher learning.

*Colleges and Universities.*—Throughout the country, but especially in the west and middle west, so called "junior colleges" are becoming numerous. The term is somewhat a misnomer. Some of these institutions are derived from small, non-tax-supported colleges which, finding themselves financially unable to continue satisfactorily the full four-year course, limit themselves to two years, and others, more significantly, from the upward extension of the vigorous public high schools. This type not only brings the opportunity for higher education within the reach of many who could not leave the immediate vicinity of their homes, but also reacts favourably on the pupils and teachers of the secondary schools from which it grew. The college remains the most characteristically American feature of educational development in the United States. In 1920 there were enrolled more than 230,000 college students. Entrance requirements have become less rigid, as indicated by the recommendation of the conservative Association of New England Colleges: that its members adopt "a system of tests for admission in which a certificate shall be taken for the quantity, and examination shall be held in a limited number of subjects for the quality, of school work." The curriculum covers a very wide range of subjects, but experience has shown that it is unwise to permit the student to exercise unhampered freedom in the choice of his studies, and most colleges now limit the selection of courses in such manner as to prevent too great concentration and too great dispersion as well. The universities, though not more numerous, have in recent years grown stronger. Their graduate departments, better manned, attract more students. In this respect the development of the state-supported institutions has been remarkable. A few years ago only three had achieved distinction in this field; by 1921, 12 had qualified for membership in the Association of American Universities, and constituted one-half of its members. The enrolment of graduate students in all universities was in 1916 11,215; in 1920 it was upwards of 16,000. So great has become the demand among women for higher education that the colleges exclusively for women are no longer able to provide for the rapidly increasing number of applicants for admission. Bryn Mawr, Vassar, Wellesley, Smith and Mt. Holyoke have been forced to establish waiting lists. The doors of the universities for the most part stand open to women upon an equal footing with men. By 1920, 44% of the students, graduates and undergraduates, enrolled in the universities, colleges and technological schools, were women, and it may confidently be predicted that they will soon outnumber the men. The general admission of women to courses in medicine removes practically the last barrier discriminating between the sexes.

*Professional Education.*—Schools for professional training have grown rapidly. Whereas a century ago professional education comprised little more than preparation for the ministry, it now includes theology, medicine, law, the new profession of engineering, and two offshoots of medicine; dentistry and veterinary medicine. Pharmacy and nursing are sometimes regarded as professions because a specialized education is precluded for those who would practise them.

*Theology.*—The colleges first founded in what is now the United States, Harvard, William and Mary, and Yale, were established to train men for the Christian ministry. As the colleges have developed into universities the original aim has been merged into the broader purpose of providing liberal education for all, while influential schools of theology have grown up,

for the most part, as strictly denominational institutions independent of the universities. During recent years the content of the curriculum and methods of teaching have been revised. Formal theology is emphasized less, a first-hand knowledge of human relationships more; Hebrew is not always obligatory, while the results of literary and historical criticism are fully discussed. Freedom of thought in some institutions has completely liberalized the training and greatly modified the traditional theology. During the years 1870-95 the number of theological students increased more rapidly than the general population. During the next 25 years the figures show marked fluctuations, but for the period as a whole neither student enrolment nor the number of graduates kept pace with the increase in population.

*Medicine.*—The medical schools of the United States were slow to adjust themselves to the new conditions brought about by the growth of medical science. They followed the model of continental Europe rather than that of Great Britain, in that the teaching was almost exclusively by lectures but imposed no definite requirement as to preliminary education. There was lacking also, for the most part, stimulating contact with colleges or universities of high academic ideals; and therefore they developed an organization which lent itself readily to commercialism. In recent years, however, medical teaching has been revolutionized, and now exemplifies the highest standards of professional education. The rapid development of physiology, pathology, embryology, chemistry and hygiene has necessitated the enlargement of the curriculum to include these subjects. Laboratory methods of teaching have been introduced at very great cost for buildings and equipment. Teachers qualified by training and experience have superseded practising physicians as instructors in the fundamental sciences; in the clinical branches also pedagogical standards have been raised. Satisfactory preliminary education is regarded as essential, and all recognized medical schools (1921) require of candidates for admission the completion of the four-year secondary school course and at least two years of college work, including physics, chemistry and biology. Cornell, Western Reserve, and Leland Stanford require three years of college for entrance; Harvard a degree from, or two years of high rank in, a college or scientific school; Johns Hopkins a Bachelor's degree or its equivalent. Most significant of all, the student is again brought into intimate contact with the sick; hospitals and dispensaries are used as laboratories where the prospective physician may acquire skill in examining patients and familiarity with the manifestations of disease. The degree of Doctor of Medicine is conferred on completion of the medical course, which in nearly all schools is four years in length. A few institutions require also a fifth year, spent as an *interné* in a hospital, before granting the degree. Advancing educational requirements, the consequently greater cost of medical training, and the increasing knowledge and interest of the public in matters of public health have combined to reduce the number of medical schools from its maximum of 162 in 1906 to 85 in 1920; of medical students from 28,142 in 1904 to 14,088 in 1920; and of medical graduates from 5,747 in 1904 to 3,047 in 1920.

*Law.*—Legal education in the United States began in a kind of apprenticeship, an intimate personal relationship with a practising lawyer. The increasing complexity of legal machinery and the resulting specialization on the part of legal practitioners rendered it impossible for a student to gain a complete education in a single office. Schools were therefore established offering systematic courses of lectures, and attendance on such schools, in addition to a clerkship in a law office, is now required for admission to the bar. The length of the law course has been increased from one to two and from two to three years and the curriculum correspondingly enriched. In some instances the student is permitted a choice of electives. Most schools have adopted the "case method" of teaching, which consists in presenting to the student the records of selected cases. These records he analyzes, and from them deduces the legal principles involved. Lectures and moot courts are also employed. The minimum of preliminary training required for admission to a recognized law school is the completion of the four-year secondary

school courses, but many of the universities demand in addition two years or more of college work. In 1921 the number of law students was more than 27,000, an increase of nearly 20% over the pre-war figures.

**Engineering.**—The beginnings of American technological training were made, not in the long-established colleges, but in a group of special schools, independently founded, such as the Massachusetts Institute of Technology in Boston and Stevens Institute in Hoboken, N.J. Later the universities took up engineering education with avidity, built up elaborate departments and offered the greatest variety of courses. Another type of technical school is the state college of "Agriculture and Mechanic Arts" supported by land grants from the Federal Government. Engineering schools require of applicants for admission the completion of the four-year secondary school course. Instruction is largely by means of laboratory courses. The university of Cincinnati has gone a step further and perfected an arrangement by which students spend half their time outside the college, actually employed in some form of engineering work; periods of two weeks of study alternate with like periods of practice in a shop. The degree of Bachelor of Science, with or without specification of the branch studied, is commonly conferred after four years of college work. Those of Civil Engineer, Mining Engineer, and so forth, are awarded for undergraduate work by some schools in place of the B.Sc.; by others reserved for more advanced study.

**Dentistry.**—Since 1900 there has been increasing uniformity among dental schools until in 1921 all recognized schools required for admission at least the completion of a four-year secondary school course, and gave four full years of professional training. It was even proposed that beginning in 1926 the entrance requirement for dental schools be raised to include two years of college work. The growing appreciation of the value of dentistry is indicated by the increase in the ratio of the number of dentists to the total population. In 1850 this ratio was 12 for 100,000; in 1910 it was 43; in 1920, 56.

**Veterinary Medicine.**—In this, as in other professions, there has come a realization of the necessity for a solid foundation of general education on which to base special training. The accepted standard in 1921 was the completion of a four-year secondary school course and three years in a college of veterinary medicine. In 1900 13 schools enrolled 362 students and graduated 100 veterinarians. In 1916 the numbers had increased to 22 schools, 3,664 students and 759 graduates. The war brought about a great reduction in the number of those choosing veterinary medicine as a career. In 1921 the number of veterinary schools declined to 14 and the student enrollment to 849.

**University Extension.**—Under this head are grouped all those activities of institutions of higher learning which are carried on for the benefit of people unable, through lack of time or training, to matriculate in the regular college or university courses, but who still desire some form of higher education, and this extension of facilities is designed to include in its scope persons many years older than the ordinary undergraduate. Originally no more than a series of public lectures on topics of literary, historical or scientific interest, this extra-mural teaching has extended its range, diversified its method, and multiplied its activities, until it has become, in some instances at least, an important function of the university. The spirit of service to the community which it embodies was expressed by the late President Van Hise in these words:—"So far as the university of Wisconsin is concerned, we propose to take up any line of educational work within the state for which the university is the best fitted instrument," and again, "It is my ideal of a state university that it should be a beneficent influence to every citizen of the state." In such a programme the whole realm of human knowledge is included, from sewing to Sanskrit and from plumbing to philosophy. Summer sessions, of from six to eight weeks' duration, provide valuable opportunities for those, chiefly teachers and students, whose work allows a long vacation. Varying standards prevail in the summer schools; in not a few the amount and quality of the work render it acceptable as part of the requirement for a degree. The university of Chicago has made its summer session the full

equivalent of one of the winter terms and operates on a four-quarter schedule. Teaching by mail is another method employed by some universities to widen their spheres of influence. Extension teaching is also carried on by local boards of education, especially in large cities. Much of it takes the form of part-time classes for children who have left school prematurely and for immigrants who lack command of the English language. Private enterprise outside of academic circles has contributed to extension teaching along two distinct lines. The Chautauqua Assembly is the prototype of the summer school, and has exerted a very wide influence through the thousands who each year attend its courses. Quite different in scope, but not less valuable, is the kind of work done by other institutions which provide opportunities and incentives for continuous and serious study as well as lecture courses and concerts having a wider appeal. Perhaps the most valuable extension teaching is that which reaches into the home, bringing to the mother such information as will aid her in solving her manifold and peculiar problems. The U.S. Government prepares and distributes upon request a comprehensive series of pamphlets containing instruction regarding the selection and preparation of food, infant feeding, child hygiene and many other subjects. Whenever possible, nurses and women trained in the household arts visit the homes and, by personal directions and demonstration, often succeed in promoting the welfare of the family where print alone would fail. Intellectual development is stimulated by courses of home reading. The recognition of the importance of home influences as factors in the child's success at school has led to the formation of "parent-teacher associations," from which the teachers gain a knowledge of the home environment of their pupils and the parents learn how best to cooperate in the education of their children.

**Vocational Training.**—This term denotes training of less than college grade, designed to fit the individual to earn a livelihood. Its beginning in the form of manual training may be traced back as far as 1880, but except for a few isolated experiments it is a development of the 20th century. Phases in the progress toward an understanding of the problem have been:—(1) attention was focussed on "misfits"; based on what might be called a "niche" theory of society, the problem was stated as that of finding the particular place or station in life that exists somewhere for each individual; (2) it was held to be the duty of society to regard with earnest concern and in some way to aid those that are defective; (3) then came the idea that the schools might prevent individual and perhaps unusual types from being spoiled in the making; (4) next came a shift in emphasis to the necessity for vocational training; and (5) finally has come a recognition of the necessity for an educational survey of the community in order to determine what opportunities are already available and what its industrial needs really are. The so-called Smith-Hughes Act passed by Congress in 1917 authorized appropriations which will aggregate \$7,000,000 a year for promoting, in cooperation with the states, special training in schools designed to meet the needs of those who are preparing to enter agriculture or industry; provision is also made for training teachers for this work by industrial or commercial corporations and by the cooperative effort of the schools and the corporations. The teaching of domestic science was begun in the schools of Framingham, Mass., in 1808. The desirability of such training for every young girl has led to the inclusion of one or more courses in home economics in the curriculum of every girls' high school and also in the upper grades of the better-organized elementary schools.

**Agricultural Education.**—Training for agricultural pursuits, more than any other branch of education, has been fostered by the Federal Government. Its development manifests several stages, each characterized by a different method. The land grants of 1862 led to the establishment of state colleges of "Agriculture and Mechanic Arts," which, however, for a generation at least, were predominantly schools of engineering. In 1887 Congress authorized subsidies to agricultural experiment stations under state control, a policy the wisdom of which was quickly demonstrated. In a few years these stations accumulated a wealth of exact knowledge relating to farm problems which

would have been of inestimable value if it could have been applied. Then came the development of agricultural extension education employing agencies such as lectures, bulletins, correspondence courses, reading courses, farmers' institutes, short courses at agricultural schools, travelling libraries, educational trains, demonstration farms, educational exhibits at fairs and moving pictures. This phase culminated in the Smith-Lever Act of 1914, which appropriated more than \$4,000,000 annually to be apportioned among the states for agricultural extension work. Such activity, creating a great demand for teachers and farm demonstrators, reacted beneficially upon the agricultural colleges. Meanwhile another tendency was becoming manifest. The science of farming was being taught in the secondary schools. This plan possessed so many obvious advantages and showed such satisfactory results, that during the decade following 1910 it was widely adopted. In 1920 1,797 public secondary schools, with an enrolment of 27,755 pupils, provided vocational instruction in agriculture. In most schools the boy or girl is required to carry out, under supervision, some definite enterprise such as the cultivation of a small plot, the raising of pigs or poultry or the conduct of a miniature dairy. A detailed record of the undertaking, including a financial statement, is required and affords a basis for grading pupils' work.

Certain private corporations, not directly engaged in teaching, have influenced education in the United States. The General Education Board, incorporated by Congress in 1903, has employed the funds at its disposal in assisting institutions of higher learning throughout the country; and in the southern states it has also promoted the development of the secondary schools and the teaching of agriculture. Recently it has entered the field of medical education. The Carnegie Foundation for the Advancement of Teaching, incorporated in 1906, starting with a programme of pensions for retiring college professors, has been led into the field of investigations and surveys. The published reports of its findings have contributed in large measure to educational progress. The Russell Sage Foundation performs similar service.

*Statistics.*—The magnitude of educational work may be indicated by figures from the report of the Commissioner of Education for the year 1918. The total enrolment of pupils amounted to 23,433,726, and the estimated total cost \$1,059,934,803, making the average outlay \$45 per pupil enrolled and \$10 the cost *per capita* of the whole population. Teachers and supervisory officers numbered 769,763, of whom 23% were men. The bureau reported 670 colleges, universities and professional schools, with an enrolment of 355,131. For the public schools of elementary and secondary grade the following figures were given:—

Number of pupils	20,853,516
Average number of days schools open	160.7
Average days' attendance by each pupil	119.8
Number of male teachers	105,194
Number of female teachers	545,515
Number of school-houses	276,827
Average annual salary of teachers	8635
Value of all school property	\$1,983,508,818
Income from permanent funds and rents	\$21,317,040
Income from local taxes	\$580,619,460
Income from state taxes	\$101,305,057
Income from other sources	\$33,434,885
Expenditure for sites, building and equipment	\$119,082,944
Expenditure for salaries	\$436,477,090
Expenditure for other purposes	\$208,118,055
Expenditure <i>per capita</i> of whole population	\$7.26
Expenditure per pupil in attendance	\$49.12
Expenditure per pupil per day	\$3.307

(A. S. D.; N. M. B.)

**EDWARD** (EDWARD ALBERT CHRISTIAN GEORGE ANDREW PATRICK DAVID), Prince of Wales (1894—), eldest son of King George V. and Queen Mary, was born June 23 1894, at White Lodge, Richmond Park, and baptized twenty-five days later by the Archbishop of Canterbury. In 1902, Mr. H. P. Hansell was appointed his tutor, and remained with him from that time until Aug. 1914. During 1902-7 the Prince was prepared for the navy, and in the spring of 1907 he entered Osborne, where he remained for two years before going on to the Royal Naval College at Dartmouth. During his time at Osborne, Capts. E. Alexander-Sinclair and A. H. Christian

were in command, and Capts. T. D. L. Napier and H. Swin Thomas at Dartmouth. On June 24 1910 he was confirmed in the private chapel at Windsor Castle. While still a cadet at Dartmouth he performed his first public duty on March 29 1911, by presenting to the mayor and corporation of that town the silver car which they held formerly as a symbol of the rights associated with the Bailiwick of the Water of Dartmouth. At the close of his Dartmouth training in June 1911 he was invested as a Knight of the Garter, and on July 13 1911 he was created Prince of Wales and Earl of Chester. He was shortly afterwards invested as Prince of Wales in Carnarvon Castle, of which Lloyd George was at that time constable, and on this occasion for the first time an English prince addressed the Welsh people in their own tongue. Shortly after this event the Prince became a midshipman, and was appointed to H.M.S. "Hindustan," in which ship he served for three months under Capt. Henry Campbell. The months which followed this cruise were spent quietly at Sandringham in preparing for Oxford, but during the spring of 1912 the Prince spent five months in Paris as the guest of the Marquis de Breteuil, during which period he was ably coached by M. Maurice Escoffier in the language and history of the country. In Oct. 1912 the Prince, accompanied by Mr. Hansell and Maj. the Hon. William Cadogan (10th Hussars), who had recently been appointed his equerry, became a freshman at Magdalen College, Oxford. During his time at Oxford the Prince entered heartily into the corporate life of his college and the usual athletic amusements of the undergraduates. The Prince resided in college rooms, dined in hall or at one of the university clubs, and mixed freely with his fellow undergraduates. Some of his vacations he spent in European travel, visiting Germany twice, in 1912 and 1913, and Denmark and Norway in 1914. The Prince's university career was ended by the outbreak of the World War in Aug. 1914 on the eve of his third year. On Aug. 7 he was gazetted 2nd lieutenant in the Grenadier Guards, and on the 15th he joined the 1st battalion at Warley Barracks, Essex.

In Nov. 1914 the Prince, who had been appointed side-camp to Sir John French, arrived in France and took up his new duties at British G.H.Q. at St. Omer. During the next 18 months he served with the Expeditionary Force in Flanders and in France in various parts of the line, being first attached to the 2nd division under Maj.-Gen. Horne, to the I. Corps under the command of Lt.-Gen. Sir Charles Mordaunt, and later to the Guards division under Maj.-Gen. the Earl of Cress. In March 1916 he was appointed to the staff of the G.O.C. the Mediterranean Expeditionary Force, and proceeded at once to Egypt. He took the opportunity of seeing the troops in various parts of the line on this front, and also went as far south as Khartoum. On his return journey he paid a visit to the Italian headquarters at Udine, and by the middle of June had returned to the British armies in France. He was then attached to the XIV. Corps (Lord Cavan) in Flanders and France, taking part in the battles of the Somme and Passchendaele, and subsequently proceeded with this corps, in Oct. 1917, to the Italian front, where he remained till Aug. 1918. In May 1918 the Prince paid a semi-official visit to Rome. The Prince then returned to France and was attached to the Canadian Corps, with whom he was serving at the time of the Armistice. He was attached to the Australian Corps in Belgium till the beginning of 1919, after which he visited the Army of Occupation on the Rhine, spending a few days with the New Zealand division, and paying a short visit to General Pershing at the American headquarters at Coblenz.

On his return to England at the end of Feb. 1919 the Prince almost immediately took up a number of public duties which had of necessity been deferred during the war, and on May 19 was admitted to the freedom of the City of London. On Aug. 5 1919 he left Portsmouth in H.M.S. "Renown" for Newfoundland and Canada, first setting foot on Canadian soil on Aug. 15 at St. John, New Brunswick. His tour extended through the entire Dominion from E. to W., and five days after reaching Victoria on Sept. 23 the return journey began by a slight

different route. The Canadian tour ended at Ottawa, and on Nov. 10 the Prince left for Washington to pay a short official visit to the President of the United States. New York was subsequently visited, and after a long series of official engagements, the Prince sailed for Halifax, where he bade good-bye to Canada, and reached Portsmouth on Dec. 1.

After a short stay in England the Prince sailed again in H.M.S. "Renown" on March 16 1920, for New Zealand and Australia. The first port of call was Barbados, and then, passing through the Panama Canal, short visits were paid to San Diego (Cal.), Honolulu and Fiji, Auckland being reached on April 24 after a voyage of 14,000 miles. A month was spent in New Zealand, visiting all parts of the North and South Is., and on May 26 the Prince landed at Melbourne. During his stay in Australia he visited all states of the Commonwealth, and eventually sailed from Sydney harbour on Aug. 19. On the return journey stops were made at Fiji, Samoa, Honolulu and Acapulco, and, after passing once again through the Panama Canal, three weeks were spent in the West Indies. The last port of call was Bermuda, and H.M.S. "Renown" eventually reached Portsmouth on Oct. 11 1920. The Prince received a magnificent reception on his arrival in London, and, as had been done on his return from Canada and the United States, the conclusion of his world-tour was celebrated by the King and Queen at a banquet at Buckingham Palace, and the Prince was shortly afterwards entertained by the Lord Mayor at the Guildhall, where he gave an account of his travels.

After a brief holiday, spent for the greater part in the hunting-field, he resumed his public duties after Christmas, 1920. During the first six months of 1921 H.R.H. was occupied chiefly in London, but found time to visit, among other places, Oxford, Cambridge, Glasgow and the Clyde; his Duchy of Cornwall property in Devon, Cornwall and the Scilly Is.; Cardiff, Newport and Bristol. On June 23 1921 the Prince spent part of his 27th birthday with 1,000 East End children who were entertained by the Fresh Air Fund in Epping Forest. On Oct. 26 he sailed in the "Renown" on a State visit to Lydia.

**EDWARDES, GEORGE** (1852-1915), English theatrical manager, was born in Ireland Oct. 8 1852. He was educated for the army but deviated into theatrical business and became manager successively to Michael Gunn at the Theatre Royal, Dublin, and to D'Oyley Carte at the Savoy theatre, London. In 1885 he joined John Hollingshead at the Gaiety theatre, London, and the next year took over the sole management of that theatre, which he ran with striking success up to the time of his death. He also built and managed Daly's theatre, was managing director of the Empire theatre and at different times acted as manager, or producer, at a number of other London theatres. Incidentally he was well known as an owner of race-horses. He died in London Oct. 9 1915, never having quite recovered from the effects of confinement in Germany, where he was interned on the outbreak of the war.

**EDWARDES, ALFRED GEORGE** (1848- ), first Archbishop of Wales, was born at Llanyamadwy Nov. 2 1848, and was educated at Jesus College, Oxford. He was ordained curate of Llandingat, Carmarthen, in 1874, and became warden and headmaster of the college, Llandovery, in 1875, holding this position until 1885, when he accepted the living of Carmarthen. In 1889 he became bishop of St. Asaph. In 1920, after the disestablishment of the Welsh Church, of which measure he had been one of the most active opponents, he was created Archbishop of Wales, and was enthroned by the Archbishop of Canterbury at St. Asaph cathedral June 1.

Amongst his publications may be mentioned *The Church in Wales* (1888); *Common-Sense Patriotism* (1894); and *Landmarks in Welsh Church History* (1912).

**EDWARDES, ENOCH** (1852-1912), British Labour politician, was born at Talk-o'-the-Hill, Staffs., April 10 1852. He was the son of a pitman, and worked as a boy in a coal-mine. In 1870 he became treasurer of the North Staffordshire Miners' Association and was elected secretary to the same body in 1877. In 1884 he

went to Burslem, where he became a member of the school board and town council in 1886, and later he became alderman and mayor. In 1880 he became president of the Midland Miners' Association; he was later president of the Miners' Federation of Great Britain and a member of the Staffordshire county council. He was elected to Parliament in the Labour interest as member for Hanley in 1906. He died at Southport June 28 1912.

**EDWARDS, JOHN PASSMORE** (1824-1911), English newspaper proprietor and philanthropist, was born at Blackwater, Corn., in 1824, the son of a carpenter, and was mainly self-educated. In 1844 he became London representative in Manchester of the *Sentinel*, an anti-Corn Law weekly newspaper. A year later he went to London and began lecturing, together with the practice of journalism, starting several small periodicals which in succession failed, until in 1862 he bought the *Building News*, which by 1866 had made a handsome profit. In 1876 he bought the London halfpenny evening newspaper, the *Echo*, and controlled it for 30 years. He was an ardent peace advocate, and supported a number of humanitarian and philanthropic objects, endowing various libraries and other institutions which bore his name, notably the settlement in Tavistock Place, Bloomsbury, now called, in memory of Mrs. Humphry Ward, the Mary Ward Settlement. He also founded a Passmore Edwards scholarship at Oxford for the conjoint study of English and classical literature. He published privately an autobiography, *A Few Footprints* (2nd ed. 1906). He died in London April 22 1911.

See E. Harcourt Burrage, *J. Passmore Edwards* (1902).

**EFFICIENCY ENGINEERING:** see SCIENTIFIC MANAGEMENT.  
**EGGLESTON, GEORGE CARY** (1839-1911), American journalist and author (see 9.17), died in New York April 14 1911.

**EGYPT** (see 9.21).—Turkish suzerainty over Egypt was formally abolished in Dec. 1914 when a British protectorate was proclaimed, while the acquisition of Tripoli and Cyrenaica by Italy and the establishment of Palestine as a separate state under a British mandate cut Egypt off from all territorial connexion with the Turkish Empire.<sup>1</sup>

**Population.**—At the census of March 1917, the inhabitants numbered 12,750,918, as contrasted with 11,287,359 in 1907, an increase of 12.9% (compared with an increase of 14.9% for 1897-1907). The number of foreigners in the country in 1917 was 238,661, a figure which owing to war conditions did not represent the normal foreign population. While the area of Egypt is some 350,000 sq. m., the cultivated and settled area—the Nile valley and delta—covers only 12,226 sq. m., and in this restricted area the inhabitants in 1917 exceeded 1,000 per sq. mile. The number of nomads and semi-nomads was estimated at 432,263. The pop. of the chief towns in 1917 was: Cairo, 790,939; Alexandria, 444,617; Port Said (including Ismailia), 91,009; Tanta, 74,195; Mansura, 49,238. Classified by religions there in Egypt in 1917: Moslems, 11,658,148; Copts, 854,778; other Christians, 155,168; Jews, 59,581, and "others," 28,448. On July 1 1919 the pop. was calculated at 12,878,000.

**General Economic Conditions.**—By 1911 the State finances had recovered from the effect of the economic crisis of 1907—a crisis due to over-speculation and extravagance following a period of much prosperity. But at the opening of 1914 the liabilities left over from 1907 still weighed heavily on private finance. The outbreak of the World War in Aug. 1914, just when the cotton crop was about to be harvested, threatened once more to place

<sup>1</sup> The question as to how far Egyptian territory extended along the Mediterranean W. of the Nile was settled in 1911. The Italians upon declaring war on Turkey in that year proclaimed a blockade of the coast as far E. as Ras el Kanais, thus reviving the Turkish claim as to the limits of Cyrenaica. The British Government on behalf of Egypt protested, maintaining that, as both Turkey and Italy had been notified in 1904, Egyptian territory extended to the Gulf of Sollum, 150 m. W. of Ras el Kanais. In this contention Italy acquiesced and the frontier between Italian territory (Cyrenaica) and Egypt was fixed at the head of the Gulf of Sollum, the small port of that name being left to Egypt. The British Government further announced that inland they regarded the oasis of Jarabub as part of Egypt. In 1919, however, it was agreed to transfer Jarabub to the Italian sphere (see SEMUSI and SEMUSITES).



Egypt in great economic difficulties. The price of cotton fell by a third and a panic was averted only by drastic measures taken by the Government. As part of these measures a general moratorium was proclaimed and an emergency currency obtained by making the notes of the National Bank of Egypt temporarily legal tender and inconvertible. But cotton, stimulated by war demands, had again risen to pre-war prices by the end of 1915, and this, together with forced economy and the large sums spent by the army stationed in the country, restored the situation. Taking the country as a whole a new period of prosperity set in, chiefly due to the soaring price of cotton—which in April 1920 was almost ten times its value in 1913. During the war exports greatly exceeded imports in value, and, deprived of normal means of employing capital in the country itself, the Egyptians sought foreign investments, putting their money to a large extent into British war securities. It was calculated that between Aug. 1914 and April 1920, as much as £E150,000,000 had been invested abroad. Yet at the same time Egypt (apart from the public debt) was still a debtor to foreign countries for a still larger sum, chiefly loans on mortgage and capital invested in industrial, transport and other companies. But the wave of prosperity—which depended to an unhealthy extent on the inflated price of cotton—was accompanied by very real distress among the *fellahin* (peasantry). The great increase in the cost of living acted upon this class (who form 62% of the pop.) with extreme severity, and their plight was accentuated by the natural tendency to extend the area under cotton cultivation at the expense of the area under cereals. The poorer classes in the big towns were even more affected than the fellahin; in Cairo in 1920 the cost of living was thrice as high as in the beginning of 1914. An attempt by the authorities to fix maximum prices was found to do rather more harm than good. The Government was reduced to seeing that certain staple articles of food—chiefly wheat, flour and maize—were supplied at reasonably cheap rates. Wheat had to be imported for this purpose and sold at prices involving a loss.

As one result of the increased cost of living there was a general demand for higher wages and improved conditions, and labour organizations resembling trade unions made their appearance. Many strikes occurred, some of long duration and some political rather than economic. A Labour Disputes Conciliation Board, established in Aug. 1919, did much good work in regulating questions of pay, hours of work, payments for sickness, etc.

The great drop in the price of cotton during the last half of 1920 naturally affected Egypt, and 1921 proved a year of considerable stringency. The restriction in the purchasing power of the community was a reflex of the fall in cotton. The price of Egyptian cotton (*sakel*) on the Liverpool market was 84.50d. in April 1920 and but 17.75d. in April 1921. The fall came too late to affect the trade returns of 1920, which were the highest recorded. The figures were largely delusive, as they were mainly the result of higher prices and not of increased production.

To a certain extent the poorer fellahin enjoyed advantages which protected them against the worst effects of bad harvests and low prices. By a law of 1912, passed at the instance of Lord Kitchener, holdings up to five *feddans*<sup>2</sup> were secured from distraint for debt, and as native owners of land of five feddans or less numbered at the 1917 census over 1,500,000, or about one-tenth of the total population, the benefit of the Five Feddans law was very appreciable. Moreover, the peasantry could obtain loans from the Agricultural Bank at the fixed rate of 8% interest.

**Agriculture, Mining and Trade.**—The Agricultural Department, established by Sir Eldon Gorst in 1910, was in 1913 transformed by Lord Kitchener into a Ministry of Agriculture. Cotton maintained its position as the mainstay of Egyptian prosperity. The crop of 1910 realized £E35,840,000, being £E5,700,000 above the previous best. The crops of 1908-1909, and 1911 were, however, poor or medium, and steps were taken to put the industry on a sounder basis. Reclamation of land had been pushed northward in the Delta into low-lying areas where there was no natural drainage, while a middle zone had become salted and water-logged. Thus arose the necessity

of drainage works on a large scale. Undrained soil, indiscriminate destruction of bird life<sup>3</sup> and the loss in seven years of a quarter of a million head of cattle through disease had led to a great increase in cotton pests, while a harmful system prevailed of mixing different varieties of cotton-seed for sowing. In Nov. 1912 a cotton congress was held in Cairo, representatives of master cotton-spinners from every European country and Japan being present. At this congress Mr. Dudgeon, director-general of the Agricultural Department, outlined a scheme whereby in five years seed for producing species approved by spinners could be obtained for the whole of Egypt. A Cotton Research Board was created in 1919 and in that year Mr. H. M. Leake, a leading authority on cotton-breeding, visited Egypt with the object of improving the quality and increasing the yield of the cotton crop. From 1916 the crop had represented practically only two varieties of cotton, *sakel* (72%) and *ashmuni* (20%)—the latter grown in Upper Egypt. The *Misafifi* and *Mubari* varieties, 26% and 15% respectively in 1913, had shrunk in 1919 to 2.2% and 1.5%. The pressing and baling of the cotton are done almost exclusively at Alexandria.

The attraction of cotton caused the cultivator to restrict the area under food crops; so much so that in 1913 and again in 1918 the Government was compelled to limit the area under cotton. The chief food crops are wheat, barley, maize, rice and sugar-cane. In 1919 the area under cotton was 1,571,000 feddans as against 1,771,000 under wheat. In 1916 the figures had been: cotton 1,677,000 feddans, wheat 1,075,000. The figures for the 1920 wheat crop were: however, illusory; in many instances wheat sown was rooted up, or allowed to be grazed by cattle, and cotton planted in its place. While the cotton crop varied considerably in amount the average annual production was about 315,000 tons. The crops of 1920 realized the unprecedented price of £E75,096,000, an increase of 15% in value over 1917, though a big decrease in quantity.

With a view to broadening the basis of the agricultural resources of the country decrees were issued (Dec. 1920-May 1921) prohibiting for the three years 1921-3 the planting of more than one-third of each holding with cotton. This action was taken at the request of the provincial councils.

From 1912 onward there was a notable development in the mineral wealth of Egypt. Nitrates and phosphates, the last-named from the Red Sea coast, together with a little gold, were up to then the chief mineral exports. Petroleum was known to exist on both shores of the Gulf of Suez but it was not till 1918 that the export of crude oil began. This was from the Gama and Sidi Barrani. In 1919 a new oil-field was discovered at Hurgada and the oil from this field did much to save Egypt from a fuel famine during the World War. This led the Government to undertake drilling operations on its own account, but up to the close of 1920 the stage of production from Government mines had not been reached. The value of the mineral output (in its raw state) rose from £E400,000 in 1914 to £E1,420,000 in 1919. Oil refineries were erected at Suez where, in 1916, harbour extensions were carried out to provide for the increase in the oil trade and the bunkering of oil-burning ships. The output of petroleum rose from 27,700 metric tons in 1913 to 281,800 tons in 1918. Phosphate was next in importance among minerals. The output varied greatly; it was 104,000 metric tons in 1913, rose to 125,000 in 1916, fell to 31,000 in 1918 and was 78,500 in 1919. Manganese ores have been exported since 1913 but the mines were much damaged by the Turks in 1915-6. In 1918 the manganese ore mined was 27,498 tons, the export 9,400 tons.

Of other industries cigarette-making at Alexandria from imported tobacco—a business almost entirely in the hands of Greeks and Armenians—showed wide fluctuations. Before the World War the tobacco was obtained chiefly from Greece, Turkey and Russia. During and after the war the place of Turkey and Russia was taken by China, India and Japan. The tobacco imported in 1913 was 7,269,000 kilogrammes; in 1919 it was 8,350,000 kgm. The export of cigarettes, 493,000 kgm. in 1913 fell to 385,000 kgm. in 1917, but rose to 561,000 kgm. in 1919.

The external trade of Egypt in the decade 1911-20 rose from £E55,826,000 to £E187,348,000, the figures for 1920 being the highest recorded. Imports in that year were £E101,880,000 and exports £E85,467,000. They compared with the previous highest returns of £E91,156,000 imports in 1918 and £E75,886,000 exports in 1919. There was a great increase of imports, following the removal of war restrictions, in 1918-20, but the rise was more in value than in quantity. In 1911 the balance of trade had been almost even, exports being £E28,598,000 and imports £E27,327,000.

As to exports, cotton, throughout the decade, represented 90% of the total; the other chief exports were cereals and vegetables, sugar, cigarettes and, from 1913-4, minerals. The largest exports in 1920, after cotton, were cotton seed and cakes, £E4,087,000; sugar, £E1,144,000; and cigarettes, £E951,000. The chief imports were cotton textiles (valued at £E18,771,000 in 1920), metal and metal ware (£E11,842,000), coal (£E8,315,000), wheat and flour (£E9,443,000).

<sup>1</sup> £1 os. 6d. approx.  
<sup>2</sup> One feddan = 1.038 acres.

<sup>3</sup> In 1912 a law was passed for the protection of birds useful to agriculture. Many of these birds, such as the buff-backed bunting (egret), had been almost exterminated. The new law proved effective and these birds again multiplied.

ool, and tobacco (£23,885,000). Much of the coal imported in 1919 and 1920 came from South Africa and Australia.

Alexandria is the principal centre of trade, taking normally over 90% of the total. Its share in 1913 was 91.8%. In that year Port Said had 11% of imports and 1% of exports. War conditions caused Port Said (and Suez) to obtain, temporarily, a much larger share—25%—of the trade, but in 1919 Port Said had dropped to 18% of imports and under 4% of exports. In that year Alexandria took 89.9% of the total trade.

The following table of the trade of Alexandria for 1913 and 1919, showing the chief importing and exporting countries, may be taken as showing the economic relations of Egypt as a whole. The most noticeable features of the table are the entry of Japan into the Egyptian market and the increasing competition of the United States. Japan first appeared as a customer in 1916.

(Values in round numbers of £E1,000.)

	1913			1919		
	Imp't from	Export to	Total	Imp't from	Export to	Total
United Kingdom	7,790	18,590	21,200	21,800	40,000	61,800
Germany	1,500	4,000	5,500	10	240	250
France	2,300	2,800	5,100	2,400	5,900	8,300
Austria-Hungary	1,900	1,700	3,600	—	—	—
Russia	900	2,200	3,100	—	—	—
United States	500	2,500	3,000	2,900	16,700	19,600
Italy	1,400	1,000	2,400	2,500	3,500	6,000
Turkey	1,900	500	2,400	—	—	—
Switzerland	130	1,000	1,130	438	650	1,088
Belgium	1,100	100	1,200	—	—	—
Greece	500	50	550	1,900	700	2,600
British India	500	30	530	2,350	600	2,950
Japan	—	—	—	1,700	1,900	3,600

The share of the United Kingdom and of British possessions in the import trade of Egypt as a whole was 37.6% in 1913 and 58.2% in 1919. In the last-named year the United States came next with 6.1% of imports, being followed by Italy, France and Greece. In 1913 the United Kingdom took 43.1% of exports, Germany 12.8%, Austria 5.6% and the United States 7.9%. The British share of the exports in 1919 was 54.3%, that of the United States 22% and of France 7.7%. The increase of United States trade was largely due to the demand for cotton, of the 1920 crop the U.S. took 35% compared with 42% taken by the U.K. and 10% by France. The value of merchandise in transit during 1920 was £E13,000,000 as compared with £E21,000,000 in 1913. It consisted almost entirely of coal and petroleum and passed largely through Port Said. Re-export trade (entrepôt), to which the geographical situation of Alexandria is peculiarly favourable, was valued at £E2,500,000 in 1920 compared with £E500,000 in 1913, and consisted mainly in the export of textiles, metal goods, kerosene, oil fuel and vegetable oils to adjacent countries of the Levant, notably Syria and Palestine.

Shipping.—The tonnage of ships entering Alexandria in 1911 was 4,095,000, the British share being 39%, Austria-Hungary coming next with 10%. In 1913 the tonnage was 3,718,000, a figure nearly maintained in 1914. During the World War the commercial tonnage greatly dwindled and in 1918 was 735,000 tons, of which 527,000 tons were British. The British passenger services were completely disorganized and this traffic was in 1919 almost wholly absorbed by Italian companies, notably the Lloyd Triestino (formerly Austrian Lloyd). Including vessels in transit through the Suez Canal, but excluding warships and all vessels on military service, the shipping figures for 1918—Alexandria, Port Said, Suez and all minor ports combined—were: Steamers, entered, 2,108; tonnage, 5,329,000; cargo cleared, 2,161; tonnage, 5,489,000. Sailing vessels entered, 422; tonnage, 20,000; cleared, 463; tonnage, 25,000.

War and post-war developments included the establishment of regular lines of cargo steamers by Japan, Norway and the United States. Trade with the United States was still, however, maintained mainly by British ships.

Railways, Telegraphs, etc.—In 1915-6 the Egyptian railway system was prolonged from Sakhia to Qantara on the Suez Canal, whence a line was built (originally for military purposes) across the Sinai Peninsula parallel to the coast, and was later continued to Jerusalem and Haifa. A steel swing-bridge over the Suez Canal at Qantara, completed in May 1918, gave through communication between Cairo and Jerusalem, but at the end of 1920 the Suez Canal Co. pressed for the demolition of the bridge on the ground of its interference with the canal traffic. The bridge was taken down by May 1921; while the question of a permanent alternative means of transit was being studied, a floating transporter carried goods across the canal in the railway trucks without break of bulk.

The railways suffered severely during the war owing to heavy military demands and had not in 1921 recovered from the overwork and arrears of maintenance. There was no considerable renewal of permanent way in the period 1912-20. This caused increased use of the canals, notably the Mahmudia Canal, which runs from the Nile at Atf to Alexandria. It is open to navigation throughout the year

and has wharfrage at Gabbari (the Alexandria goods station). In 1919 the building of short lines to give the Delta towns better access to Alexandria and Port Said was under consideration.

Wireless telegraph stations were erected at Cairo and Assiut and aerodromes laid out at Alexandria, Cairo and other towns, some of which served as stations on the trans-African route. In April 1919, a Ministry of Communications was formed, which took over control of railways, telegraphs, telephones, the post-office, ports and lights, etc., including air service. The telephone system had then recently been purchased by the State from a private company.

Irrigation.—The task of raising the Assuan dam was completed in 1912. The regulator at the head of the Menufia Canal—built about 1850—having suddenly collapsed in Dec. 1909, a new regulator had been built by Messrs Aird & Co. by July 1910, in time for the Nile floods. In 1912 extensive works for improving the irrigation and drainage of the Delta were begun, their completion was delayed by the financial stringency caused by the outbreak of the World War.

In 1916 the Egyptian Government in conjunction with the Sudan Government began investigations for new irrigation works on a larger scale. The scheme, approved in 1920 after much criticism, included the construction of a dam at Gebel Aulia, near Khartum, with a storage capacity double that of the Assuan dam, and of a barrage near Nag Hamadi in Upper Egypt. The object as defined by Lord Allenby in 1920 was to "permit the perennial cultivation of the remaining waste or basin areas of Egypt, amounting to some 1,900,000 ac. which are now uncultivated, and 1,200,000 ac. which under basin irrigation produce one crop a year." The works were also intended to reduce danger from floods. (See Sudan.)

Education.—In 1917 census returns showed that 8% of the population over five years of age could read and write as against 6% in 1907. These figures hardly reflect the desire for education among all classes. The provincial councils, which since 1910 have had part control of elementary education, showed in many instances keen interest in their work. A commission presided over by Adly Pasha, then Minister of Education, reported in 1918 that the existing schools were inadequate and outlined a scheme for sites and buildings costing over £12,000,000, with an ultimate maintenance cost of some £2,000,000 a year. In 1916 higher elementary vernacular schools were established by the Ministry of Education; in 1920 the Ministry maintained 6 and the provincial councils 18 such schools. In that year the Ministry of Education had 54 girls' elementary schools—increased interest by mothers in the education of their daughters was a feature noted by the authorities in the report for 1919. "A few years ago," it was recorded, "it was rare to find a mother taking a direct personal interest in the welfare of her daughter at school; this was left to the father who . . . often had to overcome maternal opposition to this daughter's education." In 1917, 18 per 1,000 of the female population above five years could read and write compared with 3 per 1,000 in 1907. The corresponding figures for males were 85 per 1,000 in 1917 and 120 per 1,000 in 1907. In Feb. 1920 219,642 boys and 42,911 girls attended maktab (elementary schools) under Government control or inspection.

In secondary and higher education there were no great developments during 1910-20, and no effective steps were taken to found the proposed State university. Much injury to education was caused by the strikes, for political reasons, which began among the students in many higher and secondary schools in March 1919.

Finance.—The revenue in 1911 was £E16,793,000, exceeding that of 1910 by £E87,000 and that of 1907 (the highest figure previously recorded) by £E225,000. Expenditure in 1911 was £E14,872,000. During 1913 the Domains loan was extinguished and the profit on the working of the domains became available for general purposes. The revenue had increased to £E17,368,000 by 1913 and expenditure to £E17,728,000. The effect of the outbreak of the World War was seriously to contract revenue and to necessitate great economies and the finding of new sources of income. The accounts for 1914-5 showed a deficiency of £E1,468,000. The recovery in the price of cotton and the expenditure of the British army stationed in Egypt, however, enabled the Finance Ministry to show a surplus of £E1,165,000. By 1919-20 the revenue had risen to £E33,077,000 in which year expenditure was £E28,991,000. On April 1 1920, the general reserve fund stood at £E15,576,000. Meantime, in 1917-8, the Egyptian Government had taken over charges amounting to about £E3,000,000 incurred by the Egyptian Expeditionary Force. The budget for 1920-1 (the financial year ending March 31), framed when cotton was at its highest price and trade increasing, was estimated to balance at the unprecedented figure of £E40,271,000. This included a sum of £E5,634,000 on new works. During the year the great fall in the price of cotton occurred, with a general contraction of trade, while food subsidies and emergency purchases of coal were a great drain on the revenues. The year closed with a deficit of £E12,900,000. This was made good out of the general reserve fund, which in April 1921 was reduced to £E3,000,000. The budget for 1921-2 was framed to meet the altered economic position. Revenue was estimated at £E36,707,000, and expenditure at £E38,682,000 with a draft on the general reserve fund to balance accounts.

The public debt stood on Dec. 31 1919 at £E9,209,000 sterling, of which £E2,282,000 was held by the Government and £E6,927,000 was in the hands of the public. Interest on the debt was £E3,550,000.

*Administration.*—In 1913 the two legislative bodies, the General Assembly and the Legislative Council, were replaced by a single body called the Legislative Assembly consisting of (1) Cabinet ministers; (2) 66 elected members; and (3) 17 members nominated to represent minorities. Members were to hold their seats for six years, one-third being elected every two years. The Legislative Assembly met in 1913 and had a somewhat stormy session. In 1914 martial law was proclaimed and there were no further sittings of the Assembly.

On the proclamation of the British protectorate (Dec. 4 1914) a High Commissioner replaced the British consul and agent-general. The then ruler, the Khedive 'Abbas Hilmi, was deposed and his cousin Husein Kamel, a son of the Khedive Isma'il, was placed on the throne with the title of sultan; on Husein's death his brother Ahmed Fuad Pasha became sultan (Oct. 9 1917). The capitulations continued in force pending the elaboration of measures which satisfied foreign Powers that under a new judicial system the interests of their subjects would be safeguarded. (See below, *History*.)

The most useful records of the finances, administration and social and economic condition of Egypt are the Reports of the British Agent-general published annually in London down to 1914. In 1920 appeared a Report from the High Commissioner covering the period of 1914-9, a report to which the present writer is indebted. Detailed information is given in annual reports of the various Egyptian ministries issued at Cairo. For a recent study of the Copts see S. H. Leader, *The Modern Sons of the Pharos* (1918). See also M. S. Briggs, *Through Egypt in War Time* (1918). (F. R. C.)

#### POLITICAL HISTORY 1909-21

*The Pre-war Period.*—The policy of entrusting the Egyptians with a larger administrative responsibility was initiated under Sir Eldon Gorst, who succeeded Lord Cromer as British Agent and Consul-General in 1907. Considerable success attended the extension of ampler powers to provincial councils, which in 1909 took over the direction of elementary education. But a sufficient period of time did not elapse before his premature death in 1911 to give the experiment a fair trial, and the new policy, which was generally interpreted in Egypt as an attempt to conciliate opposition by concession, rather stimulated than discouraged Nationalist agitation. In Feb. 1910 Boutros Ghali Pasha, the first Copt to attain the rank of Premier, was assassinated by a young Egyptian of the Nationalist party, which proclaimed the murderer a patriot and provoked demonstrations during his trial. Their influence had affected the General Assembly, which displayed its anglophobia by rejecting a proposal to extend the existing concession of the Suez Canal Co. after its expiry in 1968. The British Agent was compelled to recommend drastic measures to stop anti-British manifestations and Sheikh 'Abd el 'Aziz Shawish, the moving spirit behind them, was expelled from Egyptian territory. It is significant that he established his residence in Berlin. Mohammed Said Pasha became Prime Minister and Jusuf Saba Pasha, hitherto Director-General of Posts, joined the Cabinet. A long-felt want was supplied in 1910 by the creation of an Agricultural Department under the Minister of Public Works. After the murder of Boutros Pasha the tension between Copts and Moslems increased and a Coptic Conference held at Assiut in March 1911 drew up a memorandum preferring complaints of unfair treatment which the British Agent was unable to regard as justified. Sir Eldon Gorst, who had long been in failing health, requested to be relieved of his functions early in July 1911 and a few days afterwards he died. His long and intimate knowledge of the country lends special importance to his final report for 1910, in which he recognized that the Legislative Council and General Assembly had become instruments of agitation against the occupying Power and that the new policy had failed.

It might be open to question how far it would generally be opportune to appoint a former servant of the Egyptian Government to be representative of Great Britain in Egypt. An exception was, however, certainly justifiable in the case of Lord Kitchener, who had, moreover, been employed for many years elsewhere and who enjoyed exceptional prestige. He arrived

in Egypt at the end of Sept. 1911. A fortnight later the Italian landing in Tripolitania followed a declaration of war with Turkey. Egypt was at once declared neutral. H.M. Government contested on behalf of Egypt the claim of Italy to blockade the coast up to a point 100 m. E. of Sollum, that post, which was occupied by an Egyptian force, being regarded as the limit of her western frontier. In spite of a general feeling of sympathy with a Moslem belligerent, intensified by geographical proximity and racial kinship, the Egyptian people displayed self-control, and neutrality was strictly observed. But the Libyan War had the effect of stimulating the patriotic sentiment which is largely a patriotism of Islam. The anarchical spirit displayed by the murder of Boutros Pasha was again revealed in July 1912, when a plot was detected to murder the Khedive, Lord Kitchener and the Prime Minister.

Lord Kitchener's energies were first devoted to the needs of the Egyptian peasantry. A law was introduced exempting small holdings up to 5.15 ac. from distraint for debt, while usurious money-lending at more than 9% was made punishable by fine and imprisonment. Boards of local magistrates were instituted to summarily decide trivial cases and avoid costly suits. Steps were taken to preserve the bird life so necessary to keep down cotton pests. Thanks to his efforts the beautiful egret, which was rapidly being exterminated, has once more become conspicuous in the fields. A representative international cotton congress was summoned to meet at the end of 1912. In that year Mohammed Said lost the services of Sa'd Zaghul Pasha, his Minister of Justice, who subsequently became the leader of the Nationalists. But his administration was strengthened in 1913 by the formation of two new ministries, those of Waqfs (see 17.413) and Agriculture. Tension with the Khedive, however, led to his resignation in 1914. He was succeeded by Husein Rushdi Pasha, who remained in office throughout the period of the World War.

*New Legislative Assembly.*—The salient measure of Lord Kitchener's administration was a revision of the Organic Law of 1883 and the institution of a Legislative Assembly on a broader electoral basis than that of the old Legislative Council and General Assembly. Under the previous systems the villages appointed representatives by manhood suffrage to elect provincial councils. The provincial councils returned 14 members from their own body to represent the provinces in the Legislative Council, to which 12 more were nominated by the Khedive. The council of 26, with the ministers and 46 other delegates elected by the village representatives, constituted the General Assembly. All laws and decrees before approval had to be submitted to the Legislative Council, which could invite information, submit petitions and criticize the budget. The General Assembly, with similar powers of discussion and criticism, met at rarer intervals. Its concurrence was necessary for any measures involving fresh taxation, but it had no power to initiate legislation. There was no justification for the existence of two bodies performing practically the same functions, and the inclusion of members of the provincial councils, whose duties were entirely different, was an anomaly. A single Legislative Assembly was now substituted for these two bodies, with considerably extended powers, including that of initiating measures on its own responsibility. It was made incumbent on the Government to justify persistence in legislation disapproved by the majority, and machinery was also introduced enabling the Government to directly consult the electors in regard to proposals rejected by the Assembly. The electorate was based on the old register, with the addition of all newly qualified voters, and numbered some two millions. Electors were divided into groups of 50, which returned delegates to carry the vote of each group to the poll.

Three weeks elapsed between the choice of delegates and the final elections. The first Assembly consisted of 40 landowners, 2 lawyers, 3 religious dignitaries and one engineer. The president and one vice-president were appointed by the Government. An elective vice-president Sa'd Zaghul Pasha, who was already hailed by the opposition press as the champion of

Egyptian liberty, was chosen by an overwhelming majority. He led a bitter attack against Mohammed Saïd and indirectly against the British Agency in the early debates. The hostility of the new Assembly received encouragement from the Khedive, who now acted in complete understanding with the Nationalists.

*Egypt during the War.*—On the outbreak of the World War in 1914, and the change that was made in the status of Egypt, the sittings of the Assembly were suspended, and the term of its mandate expired without their having been renewed. Lord Kitchener was absent from Egypt on leave when Great Britain entered the war, and he never returned there, his services being demanded at home, where he was appointed War Minister. On Oct. 1 1914 enemy subjects were ordered by the G.O.C. in chief, Sir John Maxwell, to register themselves, and German or Austro-Hungarian male subjects of military age, or under suspicion, were deported to Malta. A proclamation of Nov. 2 placed Egypt under martial law. This enabled administrative measures to be enforced without reference to the Legislative Assembly and, where foreign subjects were concerned, without the elaborate procedure for obtaining the consent of foreign Powers. A further proclamation on Nov. 6 notifying a state of war with Turkey announced that Great Britain would take upon herself the sole burden of the war "without calling on the Egyptian people for aid therein." A number of Egyptian artillery nevertheless volunteered for service in defending the canal and took part in the repulse of the German-Turkish offensive, which was not supported by any movement in Egypt itself. Volunteer labour battalions were also raised, which played an important part in the conduct of the war. From 1917 onwards an Egyptian force, enrolled under the Frontier Districts Administration with British officers, maintained security and suppressed contraband in the Arabian and Libyan desert zone, hitherto patrolled by the coast-guards.

As the Egyptians were nominally subjects of the Sultan the entry of Turkey into the World War as the enemy of the occupying Power created an intolerable situation which demanded immediate settlement. Turkish suzerainty might have been determined by the annexation of Egypt to the British Empire. But it was decided rather to proceed along existing lines and to place Egypt under British protection. By a proclamation issued Dec. 18 the Secretary of State for Foreign Affairs gave notice that, "in view of the state of war arising out of the action of Turkey, Egypt is placed under the protection of His Majesty, and will henceforth constitute a British Protectorate. The suzerainty of Turkey over Egypt is thus terminated and His Majesty's Government will adopt all measures necessary for the defence of Egypt and protect its inhabitants and interests." A second proclamation issued the following day announced the deposition of the Khedive, 'Abbas Hilmi, who was in Constantinople, on the ground of his adherence to the King's enemies, and the acceptance of the succession by his uncle Prince Hussein Kamil, who was henceforth to bear the title of Sultan of Egypt. The arbitrary and corrupt methods of the deposed Khedive had rendered him generally unpopular with Egyptians, who had also little reason to regret the severance of the last link with Turkey. At the same time Mussulman feeling could not be indifferent to the danger which threatened the caliphate, and German agents had freely promised the eventual liberation of Egypt from British control after the victory which they confidently predicted. Sultan Hussein's position was therefore no easy one, in spite of the personal respect which he commanded.

*Sir H. McMahon, High Commissioner.*—The new status of Egypt was nevertheless introduced without disturbance, if without enthusiasm, under the direction of Sir Milne Cheekham as acting High Commissioner, pending the arrival early in 1917 of Sir Henry McMahon, who had been selected for that post. The British representative now took over the direction of foreign affairs and the Egyptian minister disappeared.

The complete failure of the Turkish attack on the Canal had its effect on public opinion, and as time went on the Sultan's personal popularity increased. On the other hand the Russian

retreat, the failure of the Dardanelles attack and the final withdrawal produced some reaction and confirmed the general impression of German invincibility. In April and again in July 1915 attempts were made on the life of the Sultan. In justice to the Egyptians, however, it should be recorded that; whatever anticipations had been raised among them as to the outcome of the war, they bore with patience and goodwill the unwelcome disabilities which it entailed, and laid Great Britain under obligations both moral and financial. Requisitions of cereals and of live stock, the control imposed on the price of cotton, recruiting for the labour and the camel transport corps, without which the Palestine campaign could not have been brought to a successful conclusion, and finally the assumption by the Egyptian Government of the whole liability for expenditure on services connected with the war, held over in a suspense account which reached £3,000,000, constituted a British obligation for which too little credit was given.

*Nationalist Propaganda.*—The war had entailed the recall of a great number of British officials from Egypt for service elsewhere, and not only was much abusive action by uncontrolled local agents ascribed to British pressure, but a free field was left open for Nationalist propaganda, which had grown ever-increasingly active as the generation died out which had experienced the pre-occupation régime. Nationalist sentiment, legitimate and worthy of sympathy in itself, might have assumed a moderate and healthy form had it not from the first received an anti-British impulse from rivalries and jealousies among the Western Powers, making use of the indeterminate position of Great Britain as a serviceable political weapon. The situation was considerably modified by the Anglo-French understanding of 1904. But the Nationalist movement founded by the late Mustafa Kemal and fanned by Sheikh Shawish and others, had assumed a definitely anti-British colour, which the ex-Khedive had at one time exploited for his own personal ends. The members of a dissatisfied civil service, who regarded the presence of an ever-growing number of British officials in the higher posts as a bar to their promotion and interest, swelled the ranks of the Nationalists, reinforced by the students, who felt that their prospect of obtaining State employment, to qualify for which they had often made real sacrifices, was diminished by the competition of the foreigner. The lawyers, a very numerous class, who anticipated that the protectorate would entail a modification of the judicial system prejudicial to their situation, were unanimously hostile, as indeed were the members of all the professional classes. Not only had British officials increased in a manner which seemed disproportionate to the expanding activities of the departments and hardly consistent with the principle of training Egyptians to manage their own affairs, but, in contradiction of that very principle, they had tended to absorb administrative functions and not merely to advise. With increasing numbers they had become a community living their own lives, wholly aloof from the Egyptians and the other foreign communities, and with this loss of contact their influence and moral control had weakened. Finally, the war between Great Britain and Turkey, the seat of the caliphate, had emphasized the latent but always present impatience of the Moslem under Christian rule. The strength which the Nationalist movement continued to acquire during the earlier and middle phases of the war does not seem to have been sufficiently realized.

*Sir R. Wingate, High Commissioner.*—In Dec. 1916 Genl Sir Reginald Wingate, who had filled the posts of Sirdar of the Egyptian army and Governor-General of the Sudan since Dec. 1899, was called to Cairo as High Commissioner in succession to Sir Henry McMahon. The health of Sultan Hussein, which had for some time caused anxiety, did not improve and it became urgent to settle the question of succession, left in abeyance in 1914. Prince Kamel ed Din, his only son, who had married the sister of the ex-Khedive, finally declined the position of heir-apparent, which was then offered to Prince Ahmad Fuad, the sixth son of the Khedive Isma'il. He had been educated at Turin, where he passed through the military school

Sultan Hussein died Oct. 9 1917. The removal from the scene of a ruler remarkable for his character, public spirit and thorough knowledge of his own country was a misfortune for Egypt. Certain modifications in the Ministry, in which it was proposed to include Sa'd Zaghul Pasha, were considered after the accession of the new Sultan. But eventually only one resignation took place, Fathi Pasha, Minister of Waqfs, being replaced by Ziwar Pasha, the Governor of Cairo. But the discussions engaged in made it clear that the Prime Minister intended on the conclusion of peace to raise the question of autonomy and the regulation of Egypt's relations with Great Britain by convention.

*After-war Plans.*—As the World War drew to a close the principles formulated by the President of the United States, to which Great Britain and her Allies subscribed, had a far-reaching and even a decisive effect on educated opinion in Egypt. The numerous declarations of British statesmen, disclaiming any intention of permanently occupying the country, were insistently recalled, and the aspirations of the Egyptians to govern themselves were represented as having received international sanction through the acceptance of the principle of self-determination. Such sentiments were by no means confined to the discontented and the ambitious, who in the furtherance of their political aims would even have welcomed a German victory. Moderate opinion also adopted the view that the attitude of Egypt during the war and the sacrifices made by her people justified a claim for special consideration and that the time had come to reconsider the relations between their country and Great Britain. When in Nov. 1918 an Anglo-French declaration was published announcing that the policy of the Allies in the East contemplated the complete enfranchisement of the peoples so long oppressed by Turkish rule and the "institution of national Governments and administrations deriving their authority from the initiative and free choice of the local populations," Egyptians felt their title to manage their own affairs to be as good as that of Syria and Mesopotamia. They, moreover, regarded their own country with its progressive organization and western methods as far ahead in development of Arabia, where an independent kingdom had already been established. At the moment when concrete expression was being given to these sentiments certain other factors combined to excite public opinion. Early in 1918 a commission had been appointed under the presidency of the Prime Minister to consider the future organization of the Legislative Assembly in Egypt. Sir W. Brunsyate, the Judicial Adviser, who during the long illness and after the death of Lord Edward Cecil also acted as Financial Adviser, was requested by the commission to prepare a basis for discussion and to consider the question of the participation in legislation of the foreign colonies, in view of an eventual abolition of the Capitulations. Another commission had already for some months been discussing the judicial reforms which such a measure would entail, and an impression which gained ground that in any new courts replacing the mixed tribunals the English language and legal procedure would predominate had confirmed the hostility of the legal profession in Egypt. The memorandum regarding the Legislative Assembly was submitted to the Prime Minister in Nov. 1918. Though only intended as a basis for confidential discussion its contents became known and were regarded as having the approval of H.M. Government. The project was interpreted as restricting the Assembly to consultative functions while all legislative power was to be vested in a Senate, in which the members officially appointed with a group of elected foreigners would constitute a majority. Its divulgence aroused a storm of indignant protest.

*Aspirations for Autonomy.*—A Nationalist committee was formed at the end of 1918, under the chairmanship of Zaghul Pasha, who now definitely became the leader of the party. On Nov. 13 he paid a visit to the High Commissioner and expressed the desire to go to London to put forward a programme of complete autonomy, a proposal which was rejected as calculated to serve no good object. At the same time the Prime Minister, with the approval of the Sultan, proposed that he should himself proceed to London with the Minister of

Education; Adli Pasha Yeghen, to discuss the affairs of Egypt, urging that, as the Peace Conference would give official sanction to the protectorate, its nature could not be left indeterminate. Sir R. Wingate appealed for their reception with some insistence. But as the Foreign Secretary and other Ministers were shortly leaving for the Peace Conference and would be unable to devote sufficient time and attention to the problem of Egyptian internal reform, they were invited to defer their visit which would not at that moment be opportune. The real urgency of the issue and the danger involved in postponing its consideration appear still not to have been fully appreciated. Rusbdi Pasha together with Adli Pasha then tendered their resignations. Every effort was made to induce the two ministers to remain in office and an approximate date was eventually suggested for the visit. But the ministerial crisis was still unsolved when in the middle of Jan. Sir R. Wingate was summoned to London to report personally on Egyptian affairs. He pressed for the immediate reception of the ministers and the withdrawal of restrictions on the movement of Nationalist leaders. The contentions of the Nationalists, to whom many of the moderates had rallied, were now receiving so much general support in the country that the ministers were only disposed to repair to London provided similar facilities were accorded to Zaghul and his colleagues. As the latter was now openly engaged in a campaign aiming at the severance of all connexion between Egypt and Great Britain, their reception by the Foreign Office could not be entertained. On the other hand the invitation to the ministers was renewed. Rusbdi Pasha, however, adhered to his resignation, which was accepted.

Meanwhile documents addressed to the foreign representatives and residents in Egypt announced that a delegation of 11 members, under the presidency of Sa'd Zaghul, had been formed to lay before other countries the legitimate aspirations of Egypt. On March 3 this delegation forwarded to the Sultan, who had declined to receive them, a petition which, though drafted with all the forms of oriental courtesy, maintained the nullity of the protectorate and was clearly designed to intimidate His Highness and to prevent the formation of a new Government. Vigorous action was therefore taken without delay. On March 8 Zaghul Pasha and three of his principal adherents were arrested and deported the following day to Malta.

*Disturbances in 1918-9.*—The immediate effects of this assertion of authority revealed the gravity of the internal situation. Anti-British demonstrations by the students in Cairo rendered military intervention necessary. On March 12 there were serious disturbances at Tanta and during the following days similar outbreaks occurred in the Delta provinces, characterized by looting and attacks on British soldiers and civilians. Railway lines were simultaneously torn up in different places, in accordance, it would appear, with a plan originally prepared for a rising had the Turkish attempt to cross the Canal proved successful. On the 16th Cairo was isolated by the severance of railway and telegraphic communication both with the Delta and with Upper Egypt, where foreign colonies were besieged in the quarter where they had taken refuge. On the 18th the fanaticism roused by the reports of unscrupulous agitators led to the brutal murder and mutilation at Deirut station of a British inspector of prisons, two officers and five of other ranks. Mobile columns had been dispatched with all possible expedition to the disturbed areas and by March 26 the main lines of communication were reestablished, the danger points were in military occupation and the situation well in hand. But it required the employment of considerable forces and stern methods of repression to restore order and prevent further bloodshed. The leaders had probably never contemplated such a serious upheaval and were alarmed at a situation which had passed beyond their control. But the Nationalist committee, which continued to sit after the deportation of Zaghul Pasha, cannot escape responsibility for the effects of their propaganda. During these and subsequent manifestations the Egyptian police in the great cities carried out their duties in an exemplary manner. The army, with the exception of a few units, was in the

Sudan, which remained entirely unaffected by events in Egypt. The extent and influence of the Nationalist organization appear to have been underestimated, and the British authorities evidently did not anticipate that within a week after the deportation of the leaders the anti-British agitation would develop into a national movement, supported by elements from every class, including the Copts, many of whom were no doubt prompted by prudential considerations to proclaim their solidarity with the Mussulman. That the fellahin, a pacific peasantry which had derived the greatest benefits from the British occupation, should have been so readily led by agitation to commit acts of savage violence had occasioned some surprise.

The movement among the fellahin was only of a very partial character, and generally restricted to the neighbourhood of large centres. At the same time several factors had by the end of 1918 combined to create a spirit of discontent and some loss of confidence in the British administration, which was made responsible for all the grievances experienced during the war. Recruiting for the labour and camel transport corps was in its earlier and really volunteer stage not unpopular, as the good wages paid were a boon to the poorer people, who enlisted again and again on the termination of their engagements. But when the voluntary system ceased to produce a sufficient number of men administrative pressure was exercised and the local officials took advantage of the absence of control. Unscrupulous Omdas in many cases abused their position, accepting bribes for exemptions and sending their enemies to serve under methods resembling those of the press-gang, while alleging British pressure as their excuse. In spite of the good prices paid, the requisition of domestic animals pressed hardly on the small farmers, who had to part with their only means of transport. Still more resented was the requisition of cereals and the manner in which it was enforced. Requisition rates ranged lower than market rates, which tempted local officials to collect larger amounts than they were required to furnish in order to sell the balance at the higher price, while cultivators who grew no wheat had to buy their quota at the market rate and sell at requisition rates. The process of verification and repayment was inevitably slow and opened the door to abuses. Collections for British Red Cross Funds, intended to be purely voluntary, were enforced by officials seeking to acquire merit for the amounts realized in their districts, and were often regarded by the ignorant fellah as a contribution imposed upon him to the British war-chest. The prices of food, clothing and fuel rose to an unprecedented degree during the war, and the average wages of the labouring class became inadequate to meet the enhanced cost of living and supply the necessaries of life. Meanwhile the fortunate producer of cotton and the privileged foreigner were seen to be accumulating fortunes. The discontent thus engendered among the poorer peasantry created a favourable field for the agitator, who proclaimed that the removal of the British occupation would ensure prosperity.

**Lord Allenby's Régime.**—Lord Allenby, the C.-in-C. in Egypt, who had left for Paris on March 12 1919, was directed to return at once as special High Commissioner during the absence of Sir R. Wingate, with instructions to restore law and order and "to administer in all matters as may be required by the necessity of maintaining the King's Protectorate on an equitable basis." The situation now passed from one of active to one of passive resistance. A general strike was maintained for only a few days, but students, lawyers and a large number of public officials declined to resume their activities. Lord Allenby adopted a policy of conciliation and, notwithstanding the dangerous interpretation to which such a rapid change of policy was liable, the removal of the embargo on the free movement of Egyptians was approved. This entailed the liberation of Zaghlul and his associates interned at Malta, who left for Paris, where their arrival almost coincided with President Wilson's recognition of the British protectorate. Their efforts to obtain a hearing at the Peace Conference were disappointed. Punitive measures for the outrages perpetrated during the outbreak inevitably tended to maintain embitterment.

On April 9 Rushdi Pasha reconstituted a Ministry with Adli Pasha as Minister of the Interior. An additional Ministry, to take charge of all communications was now instituted. But the life of the new Government was ephemeral and, having failed to terminate the official strike while deprecating intervention by the High Commissioner, Rushdi once more resigned on the 21st. A stern proclamation by Lord Allenby, acting as C.-in-C. under powers of martial law, which announced that all officials not returning to duty forthwith would be struck off the lists, had the desired effect.

**Appointment of the Milner Mission.**—H.M.'s Government now decided to send to Egypt a mission, under the chairmanship of Lord Milner, "to inquire into the causes of the recent disorders, and to report on the existing situation in the country and the form of the constitution which, under the protectorate, will be best calculated to promote its peace and prosperity, the progressive development of self-governing institutions, and the protection of foreign interests." Such were the terms of reference eventually drawn up. It would have been well if such a commission could have proceeded at once, while the impression of repressive measures was still strong, before the Nationalist movement had completed its organization, had exploited industrial unrest and extended throughout the country a propaganda which now received open encouragement from sections of the Arab university of El Azhar. But circumstances rendered its departure impossible before the autumn. A month after Rushdi's resignation, Mohammed Said Pasha (Prime Minister 1910-3) formed a new Ministry, in spite of the opposition which was henceforth to be anticipated to any combination from the Nationalists. Certain changes were also regarded as opportune in the British personnel. Sir Paul Harvey, who had resigned the position of Financial Adviser during Lord Kitchener's administration, returned. Sir W. Bruywater, who had acted in that capacity since the death of Lord Edward Cecil, also resigned his position as Judicial Adviser. Mr. Douglas Dunlop, Adviser to the Minister of Education, whose department had been much attacked, was replaced by Mr. R. S. Patterson, the Director-General of Accounts, as was Mr. Haines, the Adviser to the Interior, by Brig.-Gen. Sir G. F. Clayton, chief political officer to the Egyptian Force. A period of drift now ensued during which, though conditions appeared outwardly calm, the Nationalists continued to be active and to advocate a boycott of the Mission.

Among the arguments used to discredit the British administration much capital was made among the small landowners by the allegation of an intention to curtail the water-supply of Egypt in favour of the Anglo-Egyptian Sudan. A project had been adopted for the construction of barrages at Gebel Aulia and Sennar on the White and Blue Niles respectively. The former was designed to create a reservoir which would enable the remaining waste lands of Egypt, some 1,000,000 ac., to be cultivated, while extending perennial irrigation to some 1,200,000 more, now under basin cultivation, and therefore restricted to one crop in each year. The Blue Nile dam to be constructed near Sennar contemplated the raising of the river to a level necessary to feed a great canal which would irrigate the triangle south of Khartoum known as the Gezira, approximately equal in area to the Egyptian Delta, and suitable for raising cotton. The unfortunate attacks made by Sir W. Willcocks and Col. Kennedy on Sir Murdoch Macdonald, Adviser to the Ministry of Public Works, which were shown by the report of the eminent irrigation experts serving on the Nile Projects Commission to be unfounded, did much to encourage these misrepresentations. Charges repeatedly preferred against the Adviser of having falsified figures to justify his proposals rendered inevitable a prosecution for criminal libel which ended in conviction.

The proposal to boycott the Milner Mission gained strength from the protest of the Prime Minister against its arrival before the signature of peace with Turkey, and his resignation which followed. Wahba Pasha, who had acted as Minister of Finance in the last two Cabinets, consented with no little courage to preside over a Ministry of Affairs.



*Reception of the Mission.*—The special mission to Egypt was thus composed: Viscount Milner (chairman), Sir J. Reinell Rodd, Gen. Sir John Maxwell, Brig.-Gen. Sir Owen Thomas, Sir Cecil Hurst, and Mr. J. A. Spender, with A. T. Loyd and E. M. B. Ingram as secretaries. The mission arrived in Egypt on Dec. 7 1919. Every possible measure had been taken for its security in view of the attitude of organized antagonism which was at once openly manifested by strikes and street demonstrations in which even the Cairene ladies emerged from their seclusion to take part. Every effort was made to prevent Egyptians of note from coming into contact with the mission and those who did so were denounced in the local press. The headquarters of the mission were watched by pickets and the movements of individual members carefully followed, even into the provinces, with a view to preventing any contact with the people. Serious riots at Tanta followed a visit to that city, where military intervention became necessary.

During their stay in Cairo there was a series of attacks on British soldiers and no less than three attempts were made to assassinate Egyptian ministers by bomb-throwing. Soon after the arrival of the mission the chiefs of El Azhar University identified themselves with the Nationalists by a manifesto addressed to the High Commissioner, setting forth the claims of Egypt to complete independence and demanding the withdrawal of the British. A somewhat similar declaration signed by six princes of the khedivial family was sent in a letter to Lord Milner and simultaneously published in the press. The denunciation of the protectorate was the prevailing note.

The general hostility displayed was to some extent mitigated by a declaration issued on Dec. 20, in which the real aims of the mission were clearly stated. The belief that its object was to deprive Egypt of rights hitherto possessed was declared to be without foundation, and free expression of all opinion without limit to the field of discussion was invited. But the relations of the mission with the Egyptians were confined to informal discussion and conversations with individuals. These as time went on became so general that its members were able to thoroughly ascertain the current feeling of the country. A visit was paid by the mission to Alexandria, where its members were enabled to hear the views of the French, Italian and Greek as well as of the British Chamber of Commerce. An exhaustive inquiry was made into the working of every public department. The principal British officials were consulted, as well as the leading members of the non-official British community. Sir Cecil Hurst devoted a great part of his time to an investigation of the judicial system and the reforms which would become necessary to meet new conditions. Sir John Maxwell and Sir Owen Thomas also visited the Sudan. Before the departure of the mission in March 1920 a large volume of material had been collected, and certain propositions, on which remarkable unanimity was displayed, were provisionally drafted with a view to the preparation of a final report in England. While there had been no means of ascertaining how far a settlement on the lines contemplated would command general support in Egypt, it was clear that on certain points both extreme and moderate opinion were at one, and a solution on the basis of mutual agreement was obviously preferable to an imposed arrangement.

*Milner-Zaghlul Agreement.*—An opportunity presented itself in April, largely through the good offices of Adli Pasha, of which advantage was taken, to enter into relations with the Egyptian Delegation in Paris, who were now disposed to meet the mission in England. Meanwhile Wahba Pasha, whose health no longer permitted him to stand the strain of office, resigned on May 19 and was succeeded as Prime Minister by Tewfik Nessim Pasha. Zaghlul with seven other delegates reached London on June 7 1920. Friendly relations were established with them and, after deliberations which extended to the middle of August, the general lines of an eventual settlement were drafted. But Zaghlul and his friends were not prepared to commit themselves to acceptance without reference to their supporters in Egypt, and four members of the delegation accordingly returned to Cairo with a memorandum outlining the bases on which an agreement

might subsequently be framed. This memorandum, which came to be known as the Milner-Zaghlul Agreement, was in general accordance with the conclusions adopted by the mission in Egypt, though it went somewhat further, especially as regards the right of Egypt to foreign representation. A letter handed to Adli Pasha together with the memorandum made it clear that the latter had no reference to the Sudan, which lay outside the scope of the suggested agreement.

The proposals embodied in the memorandum may be summarized as follows:—

In order to establish the independence of Egypt on a secure and lasting basis it is necessary to define precisely the relations between Great Britain and Egypt and to modify the privileges and immunities now enjoyed by capitulatory Powers. Negotiations between accredited representatives of the Governments should contemplate:—a Treaty of Alliance between Great Britain and Egypt under which Great Britain will recognize the independence of Egypt as a constitutional monarchy with representative institutions, and Egypt will confer upon Great Britain the rights necessary to safeguard her special interests and to enable her to give foreign Powers guarantees which will secure relinquishment of capitulatory rights; Great Britain will defend the integrity of Egyptian territory, and Egypt will, in case of war, render Great Britain all assistance in her power within her own borders. This Treaty will stipulate that Egypt will enjoy rights of representation in foreign countries, and in absence of an accredited representative confide interests to the British representative; Egypt will not adopt an attitude inconsistent with the alliance, or enter into any agreement with a foreign Power prejudicial to British interests; Egypt will confer on Great Britain the right to maintain a military force on Egyptian soil for the protection of her Imperial communications; Egypt will appoint, with concurrence of H.M. Government, a financial adviser, who will take over powers now exercised by commissioners of debt and be generally available for consultation; Egypt will similarly appoint a British official in Ministry of Justice, with access to minister, to have cognizance of all matters affecting foreigners and be available for consultation regarding maintenance of law and order; Egypt will recognize right of Great Britain to intervene in case of legislation operating inequitably against foreigners; British representative will have a special position and precedence over other foreign representatives; engagements of British or other foreign officers and officials may be terminated by either party within two years after the Treaty comes into force, with pension or compensation to be therein determined.

Further provisions contemplate:—approval by a Constituent Assembly of the Treaty, which would only come into force after foreign Powers have agreed to close their consular courts; a new organic statute securing ministerial responsibility to legislature, religious toleration and protection of rights of foreigners; conclusion by Great Britain of agreements with capitulatory Powers, reserving possible the extension to foreigners of jurisdiction of mixed tribunals and of Egyptian legislation; transfer to H.M. Government of rights exercised by foreign Governments under capitulations; maintenance of existing treaties to which Egypt is a party on matters of commerce and navigation; liberty to maintain foreign schools and organize religious and charitable foundations; elimination of international element in Alexandria Board of Health; validation of all measures taken under martial law; reorganization of mixed tribunals to undertake all jurisdiction hitherto exercised by foreign consular courts; communication by Great Britain of terms of Treaty to foreign Powers and support of application by Egypt to be admitted as a member of the League of Nations.

The four delegates returned from Egypt in Oct. and accompanied Zaghlul and his colleagues to London. They reported that the proposed settlement had been well received by the Egyptian public and that any attempted opposition had met with complete failure. At the same time they had been urged to support modifications of certain specific points. These contemplated a limitation of the functions of the Financial Adviser and of the officer attached to the Ministry of Justice; abandonment of a provision postponing the coming into force of the contemplated Treaty until agreements had been concluded with the Powers for the modification of the Capitulations, and a formal abolition of the protectorate.

The mission adopted the view that no good purpose could be served by further discussion of details at that stage. These points, on which they preferred to express no opinion, as well as others, could be raised when negotiations were opened. Zaghlul Pasha stated that his efforts to create a favourable atmosphere for settlement would be weakened if he could give no undertaking with regard to these reservations and especially the abolition of the protectorate. The Egyptian delegates then

left England and the mission concluded their report, which was forwarded to the Secretary of State for Foreign Affairs on Dec. 9 1920 and presented to Parliament as Egypt. No. 1 (1921).

*After the Milner Report.*—A period of suspense ensued during which the report was translated into Arabic. Its recommendations reestablished the ascendancy of a moderate party in Egypt. After an effort to constitute a ministry representing a coalition of all parties, Adli Pasha accepted the task of forming an administration. His selection was in accord with the desire of the majority of the delegates who had visited London. It was then announced that "H. M. Government, after a study of the proposals made by Lord Milner, have arrived at the conclusion that the status of protectorate is not a satisfactory relation in which Egypt should continue to stand to Great Britain. While they have not reached final decisions with regard to Lord Milner's recommendations, they desire to confer with a delegation nominated by the Sultan with a view, if possible, to substitute for the protectorate a relationship which would, while securing the special interests of Great Britain and enabling her to offer adequate guarantees to foreign Powers, meet the legitimate aspirations of Egypt and the Egyptian people."

Zaghlul Pasha returned to Egypt from France on April 3 1921 and was received with great demonstrations of welcome. He at once took up a position of hostility to the new Government, and, though offered a place in the official delegation, was only willing to take part in it if he were himself appointed president. The majority of his former colleagues of the unofficial delegation then separated themselves from him. He declared the new Government not to be representative of opinion and a campaign of protest against the departure of the delegates was inaugurated. Moderate opinion in Egypt was unfavourable to his attitude and he only retained the support of the extremist and the turbulent elements in the country, who were, however, successful in producing demonstrations in Cairo and in Alexandria, in which city very serious riots took place on May 20, continuing through the two following days. They assumed the form of an anti-European outbreak, intensified by the nervousness of the European colonies and retaliation on their part against the demonstrators. The situation in Alexandria passed beyond the control of the Egyptian police and order had to be restored by British military intervention. Some 68 Egyptians and 19 Europeans were killed during the disturbances, and 162 Egyptians and 66 Europeans were wounded, the principal sufferers among the latter being Greeks. The effect of these riots, which were deplored by the majority of Egyptians, was to bring the question of the adequate protection of foreigners once more into prominence. Zaghlul Pasha indeed issued a manifesto deprecating attacks on foreigners and protested that the riots at Alexandria had nothing to do with politics. But the general tone of his subsequent utterances, his continued efforts to undermine the Ministry and to discredit the official delegation, only tended to bring home to him the responsibility for these unfortunate events. In the autumn of 1921 Adli Pasha visited London, where discussions took place between him and the Government as to the proposed new constitution; but an agreement was not reached, and he returned to Egypt without any further progress having been made.

*Economic Situation 1909-21.*—From the time of the economic crisis of 1907 the record of Egypt had been one of reviving and ever-increasing prosperity. The failure of the Bank of Egypt in 1911 and other failures about the same time were due to antecedent causes. The last of a succession of lean years with low Nile levels in 1910 was surmounted by the Government without recourse to a loan. The disabilities of the World War were more than compensated by the enormous prices realized for Egyptian cotton, which at one moment, in Feb. 1920, rose to 95d. per lb., ten times its pre-war price. The majority of Egyptian fortunes were invested in real estate and the competition for cotton land made £400 a not uncommon price per feddan, while instances may be quoted of land which reached £500 and even £600. Previously to the war the Egyptian financial year ran from Jan. 1 to Dec. 31. It was then modified to bring it into conformity with the British financial year and has since run from April 1 to March 31 of the following year. In 1910 the budget figures were: revenue, £E17,177,107; expenditure, £E17,077,207. Five years later, for the financial

year 1915-6, the increase was not very marked, the figures being: revenue, £E17,759,418; expenditure, £E16,903,666. But subsequently they rose by leaps and bounds, until for 1920-1 revenue and expenditure were both estimated at £E40,271,000. On the revenue side of this total £E35,675,000 represented ordinary receipts, while the balance of extraordinary revenue anticipated was derived from the sale of land and profits from the control of cotton. On the expenditure side £E32,616,920 represented recurring obligations; £E6,454,080 was assigned to new works and £E2,000,000 to loss on the purchase and distribution of articles of prime necessity. Upwards of seven millions of the increased expenditure was accounted for by the higher scale of remuneration assigned to all classes of government officials and the enhanced cost of materials. The estimated increase on state railways and the expansion of the police forces accounted for nearly two millions more.

In the course of 1920 the universal crisis in production and the cessation of demand for Egyptian cotton caused its price to drop precipitately and in March 1921 it stood at only a little above the pre-war figure. In spite of the fall of price there were few buying orders, less than 50% of the crop was shipped, and serious economic difficulties arose. Farmers were unable to pay rents which had soared up with the high price of cotton, and landowners who had speculatively increased their acreage had to mortgage their estates. Goods, which had in 1919-20 been imported on a scale unprecedented in Egypt's foreign trade record in anticipation of a continued high purchasing power, remained unsold, and the bonded warehouses were overstocked with uncleared merchandise. On the other hand the general drop in the price of commodities relieved the situation of the labouring population, and the position was rendered less acute by the large profits accumulated during the preceding period by the class most affected by the paralysis of the cotton market. It was calculated in 1920 that Egyptian savings invested abroad, largely in British Treasury bills, might be reckoned at £190,000,000, more than the whole public debt.

The break in cotton prices inevitably affected receipts from customs, sales of land and other sources. At the same time the reduction in the acreage devoted to cereals had entailed large purchases abroad, while the menace of a fuel famine had made it incumbent on the Government to ensure the coal supply in spite of the high prices prevailing. The result was that, while in the financial year 1920-1 closed with a revenue somewhat in excess of that estimated, approximately £E40,100,000, expenditure rose to £E51,000,000, of which £E8,940,000 was due to food supplies and £E6,450,000 to purchases of coal. Egypt was thus faced with a deficit of £E12,900,000, to be met by a draft on the Reserve Fund, which had greatly increased in the prosperous years 1917-20, and amounted, after due deductions for depreciation of stock, to £E15,942,866, leaving some three millions in hand to face a deficit on the budget for 1921-2.

While Egypt was enabled to meet this formidable deficit thanks to the accumulations of former years, the expansion of revenue had for a long time past fallen far short of the legitimate capacity and requirements of the country. The Egyptian financial system was inequitable and remained inelastic, owing to the impossibility of imposing taxation in proportion to wealth and of making it incident on foreign as well as on local subjects. The land-tax, when reassessed under the scheme of 1895, was fixed for a period of 30 years from the date of valuation. It was then calculated to represent about 28% of the rental value. Before many years had passed it had ceased in any way to approximate to that figure, but it could not be altered until the prescribed term had expired. Egypt, one of the richest countries of the world, remained, owing to a combination of circumstances, one of the most lightly taxed. Limitations on local taxation have similarly arrested municipal development. These disabilities have indirectly contributed to the increase of criminality by restricting the extension of the police force, while expenditure on public health and education has been inadequate.

The Egyptian debt on Dec. 31 1919 stood at £93,299,640, distributed between the three categories as follows: guaranteed loan, £6,199,900; privileged debt, £31,127,780; unified debt, £55,971,960. The Government and the commissioners of the debt held £5,282,260. The amount held by the public was thus reduced to £88,017,380. (J. R. R.)

**EHRLICH, PAUL** (1854-1915), German bacteriologist, was born in Silesia March 14 1854, of Jewish parentage. He was educated at Breslau and Strassburg, where he studied medicine. He was soon drawn towards research in chemistry, and in his earlier years carried out various important investigations in aniline dyes. He was at the same time winning fame as a bacteriologist, and in 1907 discovered a red dye, known as "trypan red," which effected the complete sterilization of animals infected with trypanosomes, a work of enormous importance for the treatment of diseases caused by these parasites. He considerably improved the technique of serum preparation, and also discovered a method by which the potency of the anti-diphtheria toxin could be tested. He also investigated the problems of cancer. Ehrlich's most famous dis-

covery, however, was made in connexion with his researches into venereal diseases. It was announced in 1910 that he had prepared an arsenical compound, known as salvarsan or "606," which was a cure for syphilis. He lectured in London in 1907, and in 1913 attended the medical congress held there. He received many honours from his Government and marks of distinction from almost every university and scientific society. He died at Homburg Aug. 20 1915.

See *Paul Ehrlich: eine Darstellung seines wissenschaftlichen Wirkens*, Festschrift zum 60. Geburtstage des Forschers (1914).

**EICHHORN, HERMANN VON** (1848-1918), German field-marshal, was born at Breslau Feb. 13 1848. He took part, as a young officer, in the campaigns of 1866 and 1870-1. In 1897 he was appointed chief of the staff of the VI. Army Corps at Breslau, in 1901 divisional and in 1907 corps commander. In 1905 he was promoted to the rank of general of the infantry and in 1913 to that of *Generalfeldmarschall*, while in the same year he was appointed inspector-general of the VII. Army Inspection at Saarbrücken. At the outbreak of the World War he was incapacitated in consequence of an accident, but was able to play a part in the battle of Soissons in Jan. 1915. In that month he was appointed to the command of the X. Army, which was engaged in the great battle of the Masurian Lakes in the following February. In Aug. he took Kovno and afterwards the fortresses of Grodno and Olita, and continued his victorious advance into Russia. From 1916-8 Eichhorn was in command of the army group known by his name in Courland. In Dec. 1917 he was raised to the rank of field-marshal and was sent to the Ukraine as chief-in-command of the German troops on the eastern front. He was assassinated at Kiev July 30 1918.

**EINEM, KARL VON** (1833- ), Prussian general, was born at Hertzberg in the Harz Jan. 1 1833. He entered the Prussian army in 1850 and rose to the rank of major-general in 1900. In the same year he was entrusted with the organization of the German section of the international military expedition to Peking. In 1903 he was raised to the rank of lieutenant-general and appointed Minister of War, an office which he held till 1909. He had meanwhile been promoted to be a general of the cavalry, and in 1909 he was placed in command of the VII. Army Corps, which under Kluck he led in the advance through Belgium in 1914. In Sept. 1914 he was appointed to the command of the III. Army (the army of the Aisne), which he successfully handled throughout the heavy fighting in Champagne in Feb. 1915. He continued his defence of his section of the German position with this army throughout 1917 and the early months of 1918.

**EINSTEIN, ALBERT** (1879- ), German-Swiss physicist, was born of Jewish parents at Ulm in the kingdom of Württemberg on May 14 1879. His boyhood was spent at Munich where his father, who owned electro-technical works, settled in the early 'eighties. The family migrated to Italy in 1894, whilst Albert Einstein went to the Cantonschule at Aarau in Switzerland, where he passed the *abiturienten* examination, the indispensable preliminary to any professional career in Central Europe, two years later. He attended lectures while supporting himself by teaching mathematics and physics at the polytechnic school at Zürich until 1900 and finally, after a year as tutor at Schaffhausen, was appointed examiner of patents at the patent office at Berne, where, having become a Swiss citizen, he remained until 1909. It was during this period that he took his Ph.D. degree at the university of Zürich and published his first papers on physical subjects. These were so highly thought of that in 1909 he was appointed extraordinary professor of theoretical physics at the university of Zürich. In 1911 he accepted the chair of physics in Prague, only to be induced to return to his own polytechnic school at Zürich as full professor in the following year. In 1914 his preëminence had become so evident that a special position was created for him in Berlin, where he was elected a member of the Royal Academy of Sciences and given a sufficient stipend to enable him to devote all his time to research without any restrictions or duties whatsoever. He was elected a foreign member of the Royal Society in 1921, having also been made previously a member of the Amsterdam and Copenhagen Academies, while

the universities of Geneva, Manchester, Rostock and Princeton conferred honorary degrees on him.

Einstein's work is so important and has proved fertile in so many various branches of physics that it is not possible to do more than enumerate a few of the most salient papers. The work by which he is best known, the theory of relativity, was begun in 1905 with the publication of the restricted principle with its consequences (*see RELATIVITY*). Though considered fantastic by many, it had secured fairly general acceptance in Germany in 1912, and was followed by the generalized theory in 1915. But Einstein's work has been by no means confined to such abstract questions. One of his earliest publications gave the complete theory and formulae of the phenomenon known as Brownian motion, which had puzzled physicists for nearly 80 years. He showed that the heat motion of particles, which is too small to be perceptible when the particles are large, and which cannot be observed in molecules since these themselves are too small, must be perceptible when the particles are just large enough to be visible and gave complete equations which enable the masses themselves to be deduced from the motions of these particles. Much of his time again was spent on the obscure problems usually combined under the heading "quantum theory." The importance of these has become more and more evident, and the difficulty of reconciling the apparently inevitable discontinuities of the product of energy and time which experiment indicates, with our accepted habits of mind, always had a peculiar fascination for Einstein. Sooner probably than anybody else he realized the far-reaching implications of the theory propounded by Planck. His paper on the variation of the specific heat with temperature, which appeared in 1907, was the first extension of Planck's fundamental hypothesis, and its verification is essentially one of the most convincing arguments in its favour. Numerous other papers on molecular physics, including an experimental research on magnetism, appeared in the *Proceedings of the Russian Academy of Science*, the *Physikalische Zeitschrift*, the *Proceedings of the German Physical Society*, the *Annalen der Physik*, etc. (F. A. L.)

**EISNER, KURT** (1867-1919), Bavarian Socialist politician and author, was born in Berlin on May 14 1867. He became a journalist, and at an early stage of his career had the first of his many experiences of imprisonment for the subversive tendency of his writings. He was successively on the editorial staff of the *Vorwärts* in Berlin 1898-1905 and of other socialist newspapers at Nürnberg and Munich. On the outbreak of the World War he at first seemed to be going to side with the Government, but, after having obtained some private knowledge of the way in which German public opinion had been duped, he turned against his own party, the Social Democrats, and attacked them for supporting the war. In Jan. 1918 he was prosecuted at Munich on a charge of treason for inciting munition workers to strike. He was released from prison on the ground that he was a candidate for the Reichstag, and recovered his liberty in time to arrange the mass meeting on the Theresienwiese at Munich on Nov. 7 1918, which the same day led to the overthrow of the Bavarian monarchy, the flight of the King, and the institution of a Bavarian revolutionary Government under the presidency of Eisner. A red-haired Jew, he possessed a magnetic and artistic temperament, and had various special methods of arousing and restraining the revolutionary masses, including orchestral and vocal concerts of high excellence in the formerly royal theatres and the opera house of Munich. His policy followed extreme lines in the sense of furthering the Workmen's and Soldiers' Councils system, while at the same time he manifested a Bavarian particularism of his own in his efforts to maintain his conceptions of republican government in conjunction with the Councils in Bavaria as against the centralizing tendencies of the Berlin policy. It was with difficulty that he was induced to agree to the arrangements for reestablishing the Federal system of the German Reich and for the election of a National Constituent Assembly. Meanwhile a Bavarian Assembly had been elected, and the Bavarian reactionaries feared that, when it assembled, Eisner's influence might continue to predominate or might even be fortified. He was, further, obnoxious to them on account of his revelations as to the origin of the war, and at an international Socialist conference at Berne he had urged the German delegates to make a clean breast of Germany's war guilt. He was on his way to open this Assembly, when he was shot dead in the street by a young Count Aroo on Feb. 21 1919. This crime was speedily followed by the Bolshevist chaos into which Munich was for a brief period plunged in April.

Ermer was the author of various books and pamphlets, which display considerable literary faculty. They include *Psychopathia Spiritualis* (1893); *Eine Junherweil* (1899); *Wilhelm Liebknecht* (1900); *Fests der Festlosen* (1903), and *Die Neue Zeit* (1919). (G. S.)

**ELECTRICAL ENGINEERING** (see 9.193).—In the articles on **ELECTRICITY SUPPLY, ELECTROMETALLURGY AND ELECTRO-CHEMISTRY, TELEGRAPHY AND TELEPHONY, PYROMETRY, ELECTRIC LIGHTING, WIRELESS TELEGRAPHY AND TELEPHONY**, various important applications of Electrical Engineering, as developed since 1910, are separately dealt with. This article deals with developments connected with the dynamo (see 8.764), and with progress as regards power stations and electric traction generally.

#### LARGE ELECTRIC SUPPLY STATIONS

Technical advances on the generation side of the electrical industry have been mainly in connexion with the wider use of the steam turbine on the one hand and with alternating-current transmission on the other. Thus the large turbo-alternator has become the standard machine for all important central stations dependent on steam. A further factor in this development has been the tendency towards the linking-up of supply stations in large areas in order to obtain increased economy—a matter which has so much importance for industry, as to call for the appointment in Great Britain in 1919 of special Electricity Commissioners to deal with it. In other countries also the statutory regulation of electric supply has been seriously discussed and in Germany state control has been adopted.

Perhaps the most important feature which affects linking-up problems and standard lines of manufacture is the question of the system, or rather of the frequency, to be adopted. In the course of natural development, the 3-phase alternating current system at a frequency of 50 cycles per second has been more and more widely used until it can now be regarded as the standard throughout Europe. On the Continent, apart from traction work for which 50/3 or 15 cycles per second have been adopted, a few stations only still operate at 42 cycles per second. In Great Britain the chief exceptions are to be found in the use of 40 cycles in the N.E. coast area, and of 25 cycles in Birmingham and the Clyde valley, the 3-phase system being still retained. With 50 cycles as the standard the turbo speeds become fixed at 3,000 revolutions per minute (2-pole machines) and 1,500 revolutions per minute (4-pole machines). Units up to 20,000 kva. have been built at the former speed, and at the latter up to 40,000 kva. In the United States the standard frequencies are

60 and 25 cycles per second, the latter being essentially used for traction purposes. The higher frequency makes the construction of large 2-pole units more difficult, but nevertheless the successful development of high-speed machinery and of reduction gearing is having a marked influence towards the higher frequency. Even 60-cycle rotary converters for traction work are becoming common. Four-pole turbo-alternators running at 1,800 revolutions per minute to give a frequency of 60 have been built up to a capacity of 33,333 kva. Steam-turbine units of as much as 60,000 kw. are in use, but in this case the high-pressure and two low-pressure turbines each drive a separate 20,000 kw. generator at 1,500 revolutions per minute.

Thus the alternator has been able to keep pace with the demands of the steam turbine as regards large powers at high speeds with high thermal efficiencies for the combination. Even comparatively small units of 6,000 to 7,500 kw. have shown an efficiency from the thermal units of the coal to the net kilowatt-hour of 18 per cent. It is possible that the normal units of the future will be in the neighbourhood of 25,000 rather than of 50,000 kw. if an output of 100,000 to 150,000 kw. should come to be regarded as the maximum desirable for any one station.

A longitudinal section through a large 2-pole turbo-alternator of modern type is shown in fig. 1, wherein will be seen the channels provided for air to ventilate both rotor and stator. A fan is attached to each end of the rotor to blow air through the stator channels, and the heated air is discharged at the top of the outer casing.

The design of large turbo-alternators presents many difficult problems. The rotor (particularly at 3,000 revolutions per minute) is commonly of the cylindrical type made from a solid steel forging, the exciting winding being accommodated in slots and the coil ends secured by means of covers forged from special alloy steels. It is only by the most rigid construction that successful rotors can be made to withstand the enormous stresses set up at peripheral velocities in the neighbourhood of 25,000 ft. per minute. The adequate ventilation of such rotors is not easily obtained, and, while both air and water ducts are used, there is a strong tendency to dispense with ducts altogether and rely on non-combustible insulation (mica) for preventing injury from high temperature. The stator also needs especial care—not only is the cooling problem difficult, but the bracing of the coil ends has to be such that no movement of the conductors is possible even under conditions of sudden short circuit.

It has doubtless been due to the rapidly increasing demands for large powers and high speeds, and the success achieved therewith, that the frequency of 50 cycles has come to be more widely adopted

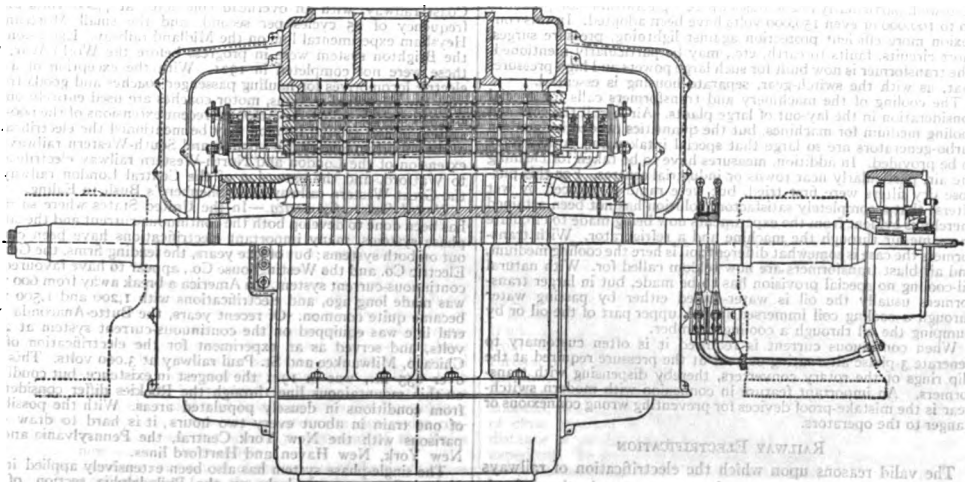

FIG. 1.—Longitudinal Section of Large 2-Pole Turbo-Alternator (Metropolitan-Vickers Electrical Co., Ltd.).

than the frequency of 25 cycles. Where the latter frequency has been retained it has been found preferable to use mechanical reduction gearing up to capacities of about 5,000 kw. Reduction gear may indeed be said to have revolutionized turbine driving for small outputs, the loss in the gearing being more than compensated by the increased efficiency of the high-speed steam turbine. It has further to be remarked that the application of reduction gearing to electrical work is still in its infancy. The greater expense of the geared drive is considered by many to be justifiable on account of its greater reliability and the higher efficiency of the plant.

The development of the continuous-current turbo-generator could not keep pace with the demand for increased output. Though satisfactory units up to 1,000 kw. were built, continuous-current turbo-generators are seldom built at the present day, except for installation on board ship. The demands of large users of continuous-current power, such as railways, chemical works, etc., are best met either by geared generators (steam turbines driving continuous-current generators through double helical reduction gearing) for moderate outputs, or by rotary converters for large outputs. Units of 2,000 to 5,000 kw. are not uncommon.

Both machines and transformers owe much of their development to the further utilization of the means for reducing the losses which occur in the iron and the copper. The use of silicon and other elements in alloy with steel in order to increase the resistance to the flow of eddy currents in iron is the factor which has been mainly responsible for the reduced weight per kva. of transformers, whilst the devices adopted for diminishing the unequal distribution of current in machines and transformers have rendered possible many modern designs.

As an instance of a modern power station may be cited that at Zachornowitz (Golpa), which at the present time (1921) is the largest steam-driven station in the world. This was erected in 1915 during the course of the war at the instance of the German Government for the supply of power for the production of nitrate of calcium in order to ensure a sufficient home supply of nitrates for agriculture and other necessary purposes. The engine-room contains 8 steam-turbine sets, each of 22,000 kva. capacity at 1,500 revolutions per minute, and the magnitude of the output may be judged from the daily consumption of about 7,000 tons of coal obtained from the lignite coal-field in the area of which the station is situated. There are 64 very large tubular boilers with 9 chimneys, each 328 ft. high, and 11 large cooling towers. Currents are generated at 6,600 volts; of the total output 6,000 kw. are supplied at 6,000 volts to the nitrate works, while 33,000 kw. are supplied to Berlin, 95 m. distant, through a 100,000-volt double transmission line to a receiving station at Rummelsburg. The State is erecting at Friedrichsfelde a large distributing station for Berlin and adjoining districts, and at this station the combined outputs of the power stations at Lauta (40,000 kw.) and Spremberg (20,000 kw.) and from the Golpa transmission will be dealt with, while a third generating station in the Lausitzer lignite coal-field is in contemplation.

The lay-out of the plant in modern stations has been mainly governed by principles of economy. Larger boilers, higher steam pressures, greater superheat, the substitution of a small number of large turbine-driven sets for a large number of small slow-speed sets have all helped in this direction. The design and arrangement of the switch-gear have also been matters on which much care has been bestowed, particularly in countries where high transmission pressures up to 100,000 or even 150,000 volts have been adopted. In this connexion more efficient protection against lightning, pressure surges, short circuits, faults to earth, etc., may be particularly mentioned. The transformers now built for such large powers and high pressures that, as with the switch-gear, separate housing is essential.

The cooling of the machinery and transformers calls for special consideration in the lay-out of large plants. Air is still the common cooling medium for machines, but the quantities needed by modern turbo-generators are so large that special intakes and outlets have to be provided. In addition, measures have to be taken for cleaning the air, particularly near towns or industrial centres. For this purpose dry filters were first tried, but were rapidly replaced by wet filters; that a completely satisfactory solution has not been attained thereby is evident from the experiments now being made to circulate the same air through the machine and a refrigerator. With transformers the case is somewhat different; oil is here the cooling medium, and air-blast transformers are now seldom called for. With natural oil-cooling no special provision has to be made, but in larger transformers usually the oil is water-cooled either by passing water through a cooling coil immersed in the upper part of the oil or by pumping the oil through a cooling chamber.

When continuous current is required it is often customary to generate 3-phase alternating current at the pressure required at the slip rings of the rotary converters, thereby dispensing with transformers. An important feature in connexion with modern switch-gear is the mistake-proof devices for preventing wrong connexions or danger to the operators.

#### RAILWAY ELECTRIFICATION

The valid reasons upon which the electrification of railways may be advocated have now become more clearly defined,

and progress has been made as these reasons have shown themselves to be applicable to specific cases. Before the World War there was a pronounced desire in certain countries to make themselves economically independent, and therefore to utilise available water-power rather than to import coal, although it was not always easy to show that any appreciable saving would accrue from electrifying railways under these conditions. The countries chiefly concerned in this way were Italy, Switzerland and Sweden. A great impetus, however, was given to this movement during the war on account of the scarcity and high price of coal, and a stage has now been reached when it is safe to say that whatever the cost of coal may be in the future, certain railway lines will no longer be worked by imported coal. Another great factor has been the difficulty of dealing with increased traffic. The introduction of the electric locomotive—by increasing the average speed, especially on inclines, and by rendering heavier train loads feasible—has in several cases proved a cheaper solution than doubling or quadrupling the track. The tunnel and terminal advantages will also be recognised.

As an indication of the importance that the electrification of main lines has assumed, reference may be made to the fact that in many countries the question has been taken up by the states concerned. The outstanding feature of all the reports and discussions that have appeared has been the debatable question of the best system. As far as can be seen at present, different countries will ultimately decide in favour of different systems.

The three systems which call for discussion are:—

- (a) The three-phase system;
- (b) the single-phase system;
- (c) the continuous-current system.

From a technical standpoint, all three systems may be said to be satisfactory. It will now be convenient to deal with the several countries separately.

*Great Britain.*—The general electrification of railways has been discussed, but has hardly received serious consideration. In 1920, a committee was appointed to advise the Ministry of Transport, and in its interim report advocated as the standard system the continuous-current system at 1,500 volts, the mode of generation of the power to be that prevailing in the district. Up to the present, practically the only lines that have been electrified have been city and suburban railways in and around London, Liverpool, Newcastle-upon-Tyne and Manchester. Until recently, the 600-volt continuous-current system, as used on tramways, was adopted for the railways, but with a third rail instead of an overhead conductor. There are now two exceptions—the Newport-Shilton mineral line 18 m. long at 1,200 volts with an overhead conductor, and the Manchester-Bury line 10 m. long with 1,200 volts and a third rail. There are only two examples of the single-phase system—the important electrification of the suburban system of the London, Brighton and South Coast railway, with an overhead conductor at 7,000 volts and a frequency of 25 cycles per second, and the small Morecambe-Heysham experimental line on the Midland railway. Extensions on the Brighton system were in progress before the World War, but these were not completed in 1921. With the exception of a few electric locomotives for hauling passenger coaches and goods trucks over the electrified sections, motor coaches are used entirely on the English electric railways. Amongst recent extensions of the 600-volt system in and around London may be mentioned the electrification of the suburban lines of the London and South-Western railway, the extension of the London and North-Western railway electrification to Watford, and the extension of the Central London railway on the Great Western railway from Shepherd's Bush to Ealing.

*United States of America.*—In the United States where so much has been done to develop both the continuous-current and the single-phase systems, many important electrifications have been carried out on both systems; but of late years, the leading firm, the General Electric Co. and the Westinghouse Co., appear to have favoured the continuous-current system. In America a break away from 600 volts was made long ago, and electrifications with 1,200 and 1,500 volts became quite common. Of recent years, the Butte-Anaconda mineral line was equipped on the continuous-current system at 2,400 volts, and served as an experiment for the electrification of the Chicago, Milwaukee and St. Paul railway at 3,000 volts. This line, over 655 m., was in 1921 the longest in existence, but conditions on this mountainous line through the Rockies differ considerably from conditions in densely populated areas. With the possibility of one train in about every two hours, it is hard to draw comparisons with the New York Central, the Pennsylvania and the New York, New Haven and Hartford lines.

The single-phase system has also been extensively applied in the United States, particularly on the Philadelphia section of the

Pennsylvania railway and on the Norfolk and Western lines, where the traffic is very heavy. There is a marked difference between the types of locomotives and of motors developed in America and those developed in other countries, and it is possible that the direction along which designers have gone in the United States has not on the whole been the most favourable for the single-phase system. At the same time it would be wrong to assume that America as a whole is in favour of the continuous-current system. The use of 16½ cycles in Europe as compared with 25 cycles in America has been much to the advantage of the former continent in single-phase work.

**Italy.**—Italy was one of the first countries in Europe to consider and adopt the electrification of its railways. At that time (1902) the three-phase system was practically the only one available for main lines, the position in this respect being somewhat akin to that on the Brighton railway when the single-phase system was chosen. The one serious drawback to the three-phase system is the need for two overhead wires at different potentials, which makes the overhead construction at points and crossings very complicated. Also the profile of certain tunnels renders the adoption of this system difficult. One undesirable result of the overhead complications is the limitation of the pressure to 3,000 volts. The objectionable double overhead potential and the choice of two other satisfactory systems have prevented the extension of the three-phase system to other countries. At the same time it should not be supposed that less success has been obtained with this system than with either of the others—indeed, the whole technical world must view with admiration the ability shown by the Italian engineers in carrying out the system. Many important State lines are now worked electrically, among which may be mentioned the pioneer Valtellina line (opened in 1902), the Giovi tunnel and the Mont Cenis tunnel lines. For mountain lines the three-phase system is peculiarly well adapted, because of the automatic regenerative braking action which occurs as soon as the motors run above synchronous speed. The original locomotives had two speeds obtained by the cascade arrangement of two motors; while the newer locomotives have four speeds, the cascade connection being combined with pole-changing devices. The power for the Italian lines is obtained from hydraulic stations, the use of water-power being important in a country without native coal.

**Switzerland.**—To Switzerland belongs the credit of much pioneer work in railway electrification ever since the Oerlikon Co. equipped an experimental line from Seebach to Wettingen. The piercing of the Simplon tunnel in 1907 was followed by the adoption of the three-phase system so as to utilize available plant as far as possible. This tunnel is 14 m. long (from Brigue in Switzerland to Iselle in Italy), and insulation difficulties were experienced with both overhead conductors and locomotives on account of the hot springs, which produced a very humid, warm atmosphere. On a cold day, a locomotive entering the tunnel from Brigue became rapidly covered with moisture. The earlier locomotives were provided with slipping induction motors, two speeds being obtained by changing the number of poles; the later locomotives have squirrel-cage rotors and are arranged for four speeds, the stators being provided with two-pole changing windings. The three-phase electrification has now been extended to Sion in the Rhodan valley. In 1912 the Loetschberg railway from Berne to Brigue (Simplon tunnel) was opened and from the outset this line was operated electrically. The system chosen was the single-phase system at 15,000 volts and 15 cycles. (This may be changed later to 16½ cycles, the frequency used on the Federal railways.) After the initial difficulties had been overcome, both in the overhead system and in the locomotives, the Swiss Government decided to apply the same system on the St. Gothard railway. In this connexion mention may be made of the important official commission which was appointed in 1904 to study the electrification of the Swiss railways. Several reports were issued by this commission, the labours of which were concluded in 1914. It has been claimed that the economy and efficiency of the single-phase system are greater than those of other systems, and this was particularly the case on the Loetschberg railway, where the single-phase overhead line is fed directly from the single-phase generating station at Spiez at the working voltage without transformers. Not only did the commission report strongly in favour of the single-phase system, but also advocated the generation of single-phase power at railway frequency (16½ cycles) rather than 3-phase generation at the industrial frequency of 50 cycles and conversion to single-phase at railway frequency. If the over-all cost of energy delivered to the locomotive, including attendance, be reckoned as unity when the current is converted from one system to another, this may be reduced to about 0.6 when conversion is dispensed with, and the latter figure can again be reduced still further when the intermediate link of transformers is eliminated. Extensions have been made on the lines adjoining the Loetschberg line as far as Berne, and the St. Gothard line (Lucerne—Chiasso) is now working electrically from Erstfeld to Bellinzona. Several of the lines subsidized by the Canton of Berne have recently been electrified and linked up with the Loetschberg railway, while many other important projects are also under consideration. It is estimated that about 30 per cent of the Swiss railways are now worked electrically.

Doubtless one of the chief causes of the success of the single-phase system in Switzerland arises from the successful development of the single-phase commutator motor for traction work. In Europe there

has always been a tendency to use fewer and larger motors and to mount them higher in the locomotive than is the case in America. Though this construction has introduced new problems with connecting and coupling rods, it has permitted the logical development of the single-phase motor. Of all the different types of commutator motor—the repulsion motor with fixed and movable brushes (Défi motor), the repulsion motor with phase compensation (Winter Eichberg Latour motor as used on the London, Brighton and South Coast railway), and the various forms of series repulsion motor—the successful survivor is doubtless the compensated series motor, the excitation required to give the E.M.F. to neutralize the transformer E.M.F. in the coils short-circuited by the brushes being obtained by suitable winding on auxiliary poles. Though such motors can be built for low terminal pressures only (200 to 500 volts) and therefore necessitate step-down transformers on the locomotive, advantage is taken of this to obtain economical and ample speed control by providing suitable tapings on the secondary of the transformer.

**Germany.**—In Germany the single-phase system has also been adopted where main lines have been electrified. The chief electrified lines are the Dessau—Bitterfeld section of the Magdeburg Hall line, the Silesian mountain lines and the Wiesental railway in Baden. Early in the present century trials had been made on the Berlin—Zossen experimental line, and it would appear that the single-phase system at 15,000 volts, 16½ cycles, will be adopted as the standard system for the German railways. The power for several of these lines is generated at 60,000 to 80,000 volts in steam stations. The electrification of the Dessau—Bitterfeld line was the alternative chosen in preference to quadrupling the tracks in order to cope with the increasingly heavy demands on this section.

Many different types of electric locomotive have been built in Germany, some of which were in accordance with the specifications of the railway engineers. Much adverse criticism was raised owing to important troubles in several constructions, arising mainly from failures in the driving mechanism. Many problems, both in Germany and Switzerland, concerning vibrations set up by the natural frequency of the system, deformation of the several parts and the play in the bearings, had to be investigated before successful solutions were found. In some cases it was found that an elastic member between the driving and the driven parts proved effective in damping the oscillations.

**Sweden.** like Italy and Switzerland, is a country without coal but with ample water-power. The first important electrification in Sweden was the Riksgräns railway, the most northerly railway in the world, situated entirely within the Arctic Circle. This railway extends from Luleå in the Bothnian Gulf to Narvik, an ice-free port on the Norwegian coast, and is used for transporting mineral ores to the latter place for export. Since the original electrification was carried out in 1910 extensions have been made, and it is hoped that the whole line will shortly be worked electrically.

The high price and great scarcity of coal towards the end of the war, and afterwards, made the consideration of the utilization of water-power extremely urgent. The expert commission appointed to study the question confined its attention to the problem of immediate urgency—the Stockholm—Gothenburg line. A careful comparison was made between the continuous-current system at 3,000 volts and the single-phase system at 15,000 volts, and it was shown that the latter was slightly better from an economic standpoint, in addition to which the Swedish railway administration and manufacturing firms were fairly well acquainted with the actual working of the single-phase system. The proposals for this scheme were accepted by the Riksdag in 1920.

**France.**—A commission was also set up in this country to study the electrification of the French railways. Before the war certain short sections had been electrified on the single-phase system, but as a result of a post-war visit to the United States, the commission appeared to be whole-heartedly in favour of the continuous-current system, at a pressure of 1,500 volts—in this respect agreeing with the findings of the British advisory committee. It is intended to make use of the waterfalls for supplying energy to the railways.

**Austria.**—Prior to the war, the Mittenwald railway between Austria and Bavaria had been electrified, and it has now been decided to adopt electrification on a general scale. The system adopted is the single-phase at 15,000 volts and 16½ cycles. Locomotives were ordered in 1920, and it was hoped to commence running in 1925.

**General.**—As general problems connected with electric traction on railways may be mentioned interference with communication circuits, regenerative braking and speed control.

In most countries telegraph and telephone lines run alongside the track, and all systems have created disturbances in these circuits from electromagnetic or electrostatic influence. Some of these disturbances are periodic and traceable to harmonics in the current in the power circuit; others, perhaps the most violent, arise from pressure surges, earths, short circuits, etc. Numerous remedies have been adopted, most of which are more or less costly. Thus the avoidance of close parallels by removing the communication circuits to a distance or placing them in underground cables is an expensive expedient. To say, as is usual, that the single-phase system causes worse disturbances than the continuous-current system could not be accepted as a general statement; some of the most troublesome cases have occurred in continuous-current systems fed from rotary



converters. However, the causes are now better understood and successful remedies are in sight. It may be mentioned that, while the French commission in their decision in favour of the continuous-current system were largely influenced by the interference question, the Swedish commission regarded it as no better in this respect than the alternating-current single-phase system.

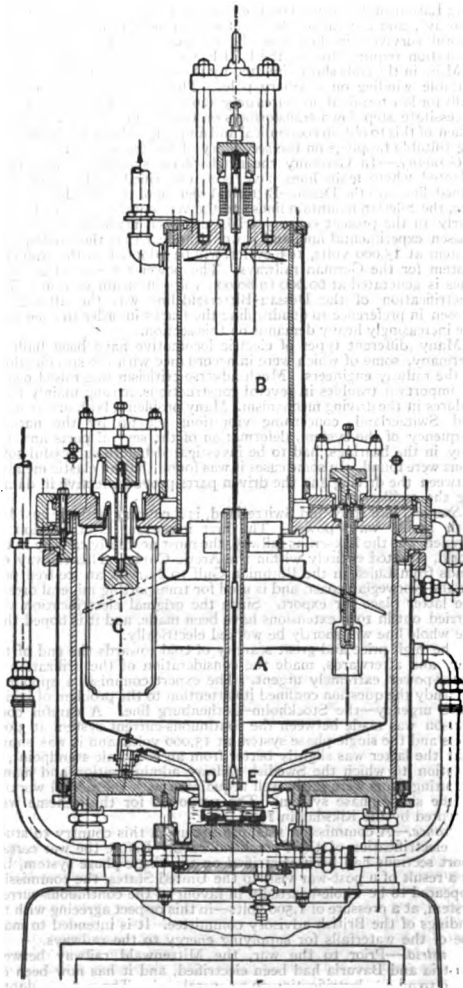

FIG. 2.—300-Ampere Mercury-Vapour Rectifier.

All three systems used for traction are capable of regenerative braking, by which is meant the use of the electric machine as a generator absorbing the mechanical energy from the train and returning it to the supply system as electrical energy. In this respect the three-phase system is simplest, for all that is necessary here is that the speed should exceed synchronous speed, in which case the induction machines act as generators. Obviously the method is not suited for bringing trains to rest. With the other two systems special devices are requisite, and though regenerative braking was first developed for continuous-current traction, successful solutions have now been developed and applied on single-phase locomotives in Switzerland, which enable the train to be brought to rest by regenerative braking. Hitherto, in the matter of regenerative braking, economy in power has usually been of less importance than the saving in wear and tear of tires, brake blocks and rails. On the lines

where such braking is applied, it is frequently impossible to utilize the returned energy, which is accordingly consumed in resistance.

Speed control can be obtained with all systems. With a continuous-current supply series, parallel connexion and field weakening together provide a limited number of economical running speeds. It must be borne in mind, however, that weakening the field reduces one of the torque-producing factors, which may entail serious increase in armature heating when the torque rises rapidly with the speed. With three-phase supply two or four speeds are obtained by cascade connexion or pole-changing devices. The single-phase system, by means of a variable-ratio transformer, provides most easily a large number of economical speeds.

Large mercury-vapour rectifiers have recently been constructed and put into commercial use; these entail further auxiliary apparatus as vacuum and water pumps, and their relative advantage or disadvantage as an alternative to the rotary converter for traction work remains to be decided in the future. Fig. 2 shows a small 300-ampere rectifier as made by Messrs. Power Rectifiers, Ltd, which can supply the rectified current at any voltage up to 750 volts. The arc operates in the lower chamber A, between the mercury cathode D and anodes C, of which there are usually six connected to the six-phase secondary of a transformer. The neutral point of the secondary is brought out and forms the negative pole of the continuous-current system, the cathode being the positive pole of that system. The arc is struck by means of the ignition anode E, which is connected by a long rod with the solenoid mounted on the top of the condensing chamber B. This solenoid is controlled by a push-button ignition switch, and the connexions are so arranged that when the anode E touches the mercury a portion of the current which was previously flowing through the solenoid coil is diverted; this allows a spring acting in opposition to the solenoid to rise again the ignition anode. The rectifier is cooled by water circulated through the base of the cathode, through a jacket round the arc chamber, and thence through the plate in which the anodes are mounted and the jacket round the condensing chamber. Large sizes dealing with 600 and 1,000 amperes are manufactured, and for larger outputs two or more rectifier cylinders are placed in parallel and connected to a single transformer.

#### HYDRAULIC ELECTRIC STATIONS

Probably in no direction has greater progress been made of recent years than in the utilization of water-power. In all civilized countries throughout the world plants have been installed and projects drawn up for utilizing this natural source of energy. An idea of what is possible and of what has been done in this direction is obtained from the following approximate table taken from a paper by E. M. Bergstrom (*Inst. Mech. Eng.* 1920):—

B.H.P.

Country	Available	Developed	Per Cent
U.S.A.	28,100,000	7,000,000	24.9
Canada A	18,803,000	1,735,000	9.2
" B	8,094,000	1,725,000	21.3
Austria-Hungary	6,460,000	566,000	8.8
France	5,587,000	1,100,000	11.6
Norway	5,500,000	1,120,000	20.4
Spain	5,000,000	404,000	8.1
Sweden	4,500,000	740,000	15.6
Italy	4,000,000	976,000	24.4
Switzerland	2,000,000	511,000	25.5
Germany	1,425,000	618,100	43.4
Great Britain	993,000	80,000	8.1

Low, medium and high falls, ranging from 4 ft. (e.g. on the river Main) to 2,700 ft. of head (e.g. at Luchon on the French Pyrenees) have all been brought into service. To take one instance only, the modern water-power station on the river Dal, about 80 m. from Stockholm, contains four turbines, each of 10,000 H.P. coupled directly to dynamos at 125 revolutions per minute, and larger sets up to 50,000 H.P. are not uncommon. The latest (1920) station of the Southern Power Co., operating in S. Carolina, U.S.A., has been installed on the Wateree river for 90,000 H.P. and contains five turbines, directly coupled to generators each of 18,000 kva. The extension of station No. 3 of the Niagara Falls Power Co., developing an additional 100,000 H.P. at Niagara, is noteworthy for the inclusion of 32,500 kva. 12,000-volt three-phase alternators running at 150 revolutions per minute and a frequency of 25 cycles per second. One of these, manufactured by the Allis Chalmers Mfg. Co., is shown in fig. 3.

For high falls Pelton wheels are employed, and in the case of Luchon, quoted above, each Pelton wheel develops 6,200 H.P. at the high speed of 1,500 revolutions per minute. Still higher heads are being utilized, and owing to the high costs of material and

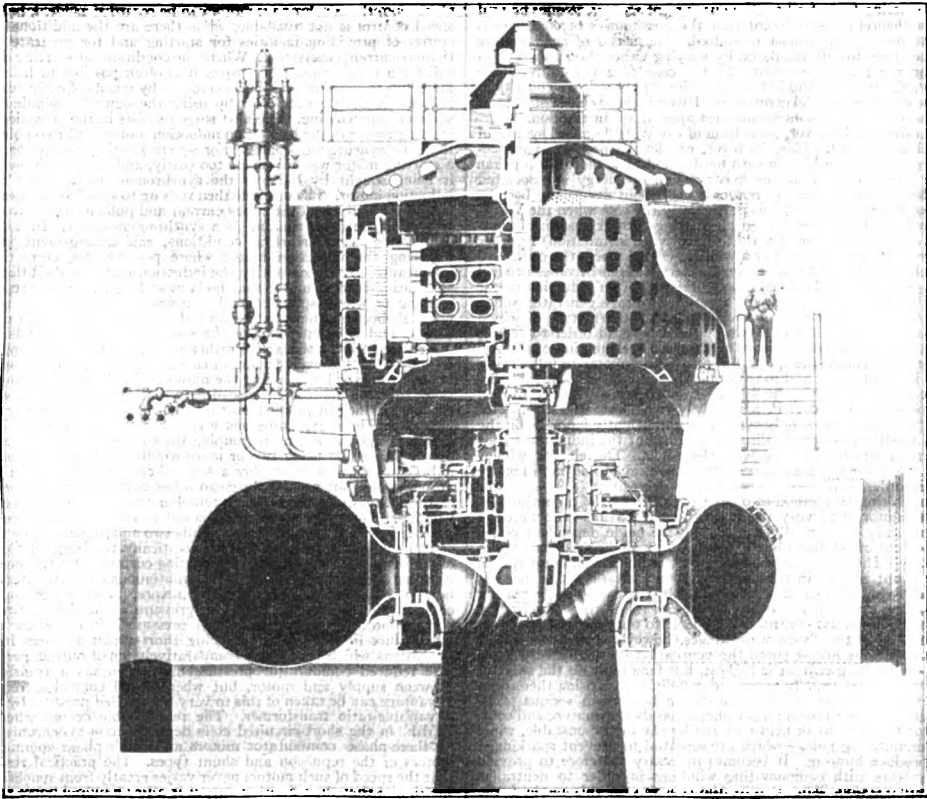

FIG. 3.—32,500-kva. Combined Water-Turbine and Alternator.

labour, the tendency is to favour the development of high-head falls which require less civil engineering owing to their smaller volumes of water. The chief problem in the design of water-wheel alternators is in the construction of the rotor. Owing to the possibility of racing, water-turbine-driven sets have to be capable of withstanding overspeeds of 80 to 100%. In many cases the peripheral speed is high on account of the large output, while large diameters become necessary to meet the demands for fly-wheel effect. The result is that a very rigid construction is necessary for the rotor, usually embodying some modification of the dovetail for securing the poles and field windings. The stator windings also, as in turbo-alternator, have to be securely braced in order to withstand the severe conditions of sudden short circuit. It is customary to make water-wheel alternators totally enclosed to reduce windage losses, to assist artificial ventilation and to protect the machine against possible leaks from the turbine.

Small hydro-electric stations are now in action which are either entirely automatic and actuated by a change of water level, or set in operation by remote control in accordance with the demands for power from the network. A case of interest as involving the export of energy is the hydro-electric transmission of power up to 20,000 H.P. from the power-station of Gøsen on the river Aar in Switzerland to a distributing station situated in France, where the supply is placed in parallel with the steam-driven station of Vincly. Transmissions from Norwegian waterfalls to Denmark and Sweden are also contemplated.

One reason for the comparatively small amount of power utilized in Great Britain has been the abundance of coal. In many cases the development of water-power has only become possible since coal became dear and scarce, for it must not be forgotten that hydraulic installations are frequently very costly on account of the civil engineering works that have to be constructed in places difficult of access, and of the long high-tension transmission lines.

In many countries water-power is now being developed in accordance with definite policies. Thus in Switzerland, where the linking-up of stations has been adopted on a wide scale, the low-head power stations in the valleys, which utilize river energy, are designed to supply the mean power and therefore to run on practically constant load, while the "peak" loads are supplied by the high-head stations in the hills, which are fed from natural lakes or reservoirs in which the water is impounded by means of dams.

In Italy power is available from the Alps in summer from the melting of ice and snow, and from the Apennines in winter from rain. By linking up the several stations a continuous supply of energy is assured. In Germany the canalization of rivers is carried out hand-in-hand with the supply of electric energy by building power-stations at the weirs.

Wave-power, tidal rise and fall, and tidal currents in estuaries have all received attention, especially in France, as possible sources of power in the future, and a large scheme for utilization of the water-power available from the Severn has been proposed, but in no case have the projects advanced beyond the stage of discussion.

#### APPLICATIONS OF ELECTRIC MOTORS

One of the main factors in the development of electrical supply has been the extended use of electric motors for driving machinery of all kinds. In addition to the numerous class of simple, straightforward drives, the electric motor has been applied with success under more difficult conditions, demanding large starting torque, considerable powers and wide variations of speed. Along with this development has been the extension of the three-phase system, in consequence of which there has arisen a wide demand for variable-speed, alternating-current motors. Some directions of their application may be dealt with.

Considering first of all continuous-current motors, it may be said from a theoretical standpoint that the possibilities of continuous-current motors are almost unlimited. The speed of such motors may be economically regulated by varying either the applied pressure or the exciting current. In the case of a constant-voltage supply, the usual method of varying the supply voltage consists in the use of series-parallel connexion. This involves the use of at least two motors and finds its commonest application in traction.

Occasionally, however, some form of the Ward-Leonard system of control is adopted. This, however, entails the use of a variable-voltage generator, which in turn needs an electric motor or a prime mover to drive it. Since each conversion of energy is associated with loss, such systems are not only costly but eventually become more or less wasteful. This is particularly the case when the Ward-Leonard control is used on an alternating-current system of comparatively small power (e.g. that of a private installation) in order to drive, say, a rolling-mill or a winding-engine where the peak load is much in excess of the mean load. Here it often becomes needful to supply a fly-wheel converter set consisting of an induction motor with slip regulator (see below), a variable-voltage generator and a fly-wheel, in addition to the driving motor, the armature of which has often to be divided into two or three parts in order to reduce inertia when rapid reversals are necessary. The function of the slip regulator is to allow the speed of the induction motor to fall when a heavy load comes on, and so to permit the excess load to be taken up by the stored energy in the fly-wheel. Such sets often have to deal with peaks of 20,000 H.P. and may give an overall efficiency of 50-70%. Where the supply systems are sufficiently large, as on the Rand, the fly-wheel can be dispensed with, but the induction motor must then be able to cope with the peaks. The electric winder affords a good example of the problems that have to be met in many cases in order to replace a steam-engine drive.

A much simpler method of controlling the speed of a continuous-current motor is to vary the exciting current. This can be done automatically or manually, and it may be made dependent on or independent of the load; but in every case a single machine only is necessary. The usual continuous-current motor for different speeds is the shunt motor; in this, with a given excitation, the speed is practically independent of the load; but by increasing or decreasing the exciting current the speed is lowered or raised respectively. By this method of shunt control it is possible to obtain speed ranges as high as 1.5 or 1.6. Such wide ranges, however, make the design difficult. At the lowest speed the ventilation is usually very poor, while the exciting current is highest, but fans built on the shaft of the armature can usually overcome any difficulty arising therefrom. It is at the highest speed that serious trouble becomes a real probability. In addition to the high peripheral speeds of armature and commutator the very weak field may render the motor unstable, while the commutating poles—which are essential to prevent sparking—may produce hunting. It becomes necessary therefore to provide such motors with compensating windings in order to neutralize armature reaction. Thus despite the economy of this method, the motors become costly when wide speed ranges are demanded.

Series motors in which the exciting winding is in series with the armature winding, and in which in consequence the speed becomes a function of the load, are widely used for drives where there is no danger of the load being removed—e.g. for traction or for fans, cranes, etc., but the only common application of voltage and field control of series motors is for traction work.

The compound-wound motor combines the shunt and series characteristics in varying degree, according to requirements. If a series characteristic is required with merely a limiting top speed, it is only necessary to provide the motor with a small shunt winding in addition to the series winding in order to prevent racing. When, however, an increased torque at starting or a fall in speed in the case of overloads is demanded, a small series winding is added to the shunt winding. In the former case the series winding may be short-circuited if desired after a definite speed has been reached.

Except in cases where a variable voltage is applied to the motor, starting resistances are necessary with continuous-current motors, so that continual starting becomes wasteful. For general speed control the continuous-current motor is doubtless unrivalled, and where circumstances justify the outlay conversion from alternating to continuous current is the best solution. A typical case would be a factory in which several variable-speed motors are installed.

Coming to the alternating-current side, mention must first be made of the question of power-factor rectification. The alternating-current, three-phase system having established itself as the standard method of transmission, vigorous attempts are being made in every country to keep the power-factor of such systems as high as possible, in order to secure the minimum outlay in transmission and generation. Obviously, with three-phase supply it becomes highly important to employ wherever practicable three-phase motors, but in any such application the power-factor must not be overlooked. Broadly speaking, the user does not stand to gain by ignoring this question, for whether the rectification is achieved by him or by the power company, or is done at all, the consumer has to pay.

Though with alternating current there are more types of motors available than with continuous current, speed control presents a more difficult problem. From the point of view of power-factor

correction, the synchronous motor can be regarded as ideal, but its speed control is not available, while there are the additional difficulties of providing facilities for starting and for separate (continuous-current) excitation. Where the conditions at starting do not call for a large amount of torque, it is often possible to bring the motor up to speed on an induction motor by means of eddy currents induced in the pole shoes or by using the damping winding as a squirrel-cage winding. The next stage consists in the provision of a starting motor in the form of an induction motor with two poles less than the synchronous motor. For severe starting conditions, such a starting motor would become too costly, and the present solution is being sought by building the synchronous motor itself as an induction motor. The machine then runs up to speed as an induction motor, is excited by continuous current and pulls into synchronism, whence it continues running as a synchronous motor. In addition to meeting severe starting conditions, this arrangement is also replacing the induction motor where power-factor correction is important. By its simplicity the induction motor is doubtless the alternating-current motor that finds most favour. Where repeated starting or where speed control is necessary the motor is uneconomical, because the input to an induction motor depends on the torque, and is independent of the speed. Nevertheless it is often preferable to incur this waste rather than to install converting sets. It is possible, however, to obtain economical speed control with an induction motor by changing the number of poles or by connecting two induction motors in cascade in each case, however, with a certain sacrifice in power-factor as well as through the extra cost incurred. There are numerous ways of effecting a change in the number of poles—e.g. by regrouping the coils, by varying the number of phases, by using two or more windings, etc.—and generally it becomes needful to employ a squirrel-cage rotor. Such a rotor, however, does not necessarily mean a low starting torque, for some of the locomotives used on the Simplon tunnel railway have such windings. Generally speaking, it is not usual to obtain more than six speeds with induction motors, while two and four are more usual.

The commutator motor offers theoretically the best solution for obtaining speed control with alternating current, and the possibilities here are the same as with continuous current. Actually, however, the limitations are more severe, because not only do commutation conditions limit the pressure as in the continuous-current motor, but the transformer pressure induced by the alternating flux in the coils undergoing short-circuit imposes further limitations which result in a comparatively small output per pole. The reduced commutator pressure usually entails a transformer between supply and motor, but where speed control is required advantage can be taken of this by using the applied pressure by using a variable-tap transformer. The real trouble occurs when the E.M.F. in the short-circuited coils depends upon synchronism, as in three-phase commutator motors and single-phase commutator motors of the repulsion and shunt types. The practical result is that the speed of such motors never varies greatly from synchronous speed, and that their limiting output is a few hundred horse-power. On the other hand, types like the single-phase series commutator motor, free from this restriction, have been successfully built for outputs of over 1,000 H.P. and speed ranges up to four or five times that of synchronism. Despite limitations, alternating-current commutator motors are becoming more widely used, particularly for small outputs; while as cascade or auxiliary motors they have been successfully applied for utilizing the slip energy of large induction motors. Variable-speed sets of this kind will probably be more widely developed in the future, particularly when the properties of alternating-current commutator motors come to be better understood.

**AUTHORITIES.**—As additional authorities may be consulted: Miss Walker, *The Specification and Design of Dynamo-Electric Machinery* (1915); Hawkins, Smith and Neville, *Papers on the Design of Alternating Current Machinery* (1919); Alexander Gray, *Electrical Machine Design* (1913); A. T. Dower, *Electric Traction* (1917); and C. Klingsberg, *Bau grosser Elektrizitätswerke* (1920). (C. C. H.; S. P. S.)

**ELECTRICITY SUPPLY (see 9.198).—UNITED KINGDOM.**—In its commercial aspects the history of electricity supply in the United Kingdom from 1910 to 1914 was comparatively uneventful. No fresh legislation was passed; no new supply schemes of the first magnitude were brought forward. The supply undertakings were in the main content with steady development among both industrial and domestic consumers. Advances were more rapid in the lighting field on account of the appearance of the drawn-wire tungsten lamp, first in the vacuum type and later in the gas-filled type. Improvements in cooking and heating apparatus also stimulated the domestic day load. The war, however, arrested the growth of the domestic demand and brought an urgent and practically unlimited call for electric power in factories and workshops extended for war purposes and in new factories erected for the production of munitions of war. During the first months of war the need was met by running all the plant (including reserves) available in public generat-

ing stations to its full capacity. The margin of power thus pressed into service was of great value in accelerating the output of munitions, and when the Ministry of Munitions was formed—in the spring of 1915—no special department to organize the supply of electric power was thought necessary. Within a few months evidence of the vital importance of electricity for almost every war demand had become so strong that a department was formed to deal with all electrical engineering questions. All proposals for the extension of generating stations and mains had to be brought before the Electric Power Supply Department of the Ministry, which issued priority certificates for those judged to be most urgent. The output of electrical manufacturing firms was likewise controlled, so that the production of both electric power and electric plant was centrally organized to meet the ever-increasing demand for current.

Between June 1914 and Oct. 31 1918 the plant capacity of 327 municipal undertakings rose from 705,000 kilowatts (K.W.) installed to 1,490,000 K.W. installed or on order, and of 230 company-owned power stations from 430,000 K.W. installed to 983,000 K.W. installed or on order. Thus the additional generating plant installed or on order during the war aggregated 1,143,000 K.W., and was almost exactly equal to the total plant capacity existing at the outbreak of war. Further, considerable orders were placed for private electric generating plants, particularly in connexion with the extension of iron and steel works, where waste heat was available. All of the additional power was required for power, smelting, and other industrial purposes. New connexions for domestic purposes were not made, and owing to military requirements, coal shortage, and other causes restrictions were placed on public and private lighting and on the general domestic consumption of electricity. Exact statistics of total domestic demand are not available, but in this direction there was a substantial diminution in output during the war.

The capital cost of these extensions, including mains and sub-stations, was about £23,000,000. They were financed, where necessary, by Treasury issues of interest-bearing loans, repayable by annual instalments over 15 years or so. Further, the Ministry of Munitions was empowered to guarantee to bear the difference between the cost of carrying out extensions during the war and the estimated cost of the same work if carried out at a period, generally one or two years, after the period of hostilities, and also to meet the cost of any portions of extensions found to be in excess of the post-war needs of the undertaking. The object of this arrangement was to put the undertakings in the position they would have occupied if they had not extended during the war, but had waited until their post-war requirements had to be met. About £3,150,000 out of the total of £23,000,000 was thus advanced by the Ministry of Munitions. Some applicants pressed for definite Government grants, but these were refused on the ground that electric supply undertakings enjoyed a monopoly with perpetual or lengthy powers for the supply of a commodity required after the war, and were therefore in a different position from manufacturers called upon to undertake a form of production not needed under peace conditions.

The general policy of the British Government was to encourage power users to take current from the public mains rather than to erect separate small generating stations. Even where private plants were sanctioned, as in the special cases mentioned above, linking-up with an adjacent public service undertaking was arranged wherever possible. Public supply undertakings were also in some cases linked together for mutual assistance.

During the war there was a marked increase in the average size of generating units, an improvement in load factor, and a reduction in the costs of generation. Before the war the average size of generating unit installed was 522 K.W., with 8,000 K.W. as the capacity of the largest unit. At the end of Oct. 1918 the average size was 7,044 K.W., and units of 25,000 K.W. and 30,000 K.W. were being built. In 1914 the coal consumption per unit sold was 4·1 lb.; in 1918 it fell to 3·75 lb. in spite of the very inferior fuel then in use—an improvement due to the larger and more efficient plant and the rise in load factor resulting from concentration of load.

Two special control orders were imposed on the industry by the Ministry of Munitions. The first—Converter Plant Control Order, 1918 (issued April 5 1918 and cancelled Feb. 28 1919)—was designed to reduce the demand for converter plant and to assist supply engineers in persuading customers (especially ship-building firms) that the alternating current available was quite suitable for their requirements. The second was the Electricity (Restriction of New Supply) Order, 1918, issued on Nov. 8. A shortage of coal had arisen in the early part of that year owing to large withdrawals of miners for active service, and from other causes; and the coal controller accordingly rationed the use of coal. As the Ministry of Munitions undertook to limit new electrical connexions to consumers wholly engaged on urgent munitions work the rationing was not applied to power stations. Concurrently with the issue of this order the coal controller rationed the use of both electricity and gas for domestic purposes. On Jan. 10 1919 the order was revoked.

In spite of the enormous increase in output, which made the four years of war equivalent in electrical growth to the previous 32 years of industry, the financial condition of the undertakings did not, on the whole improve. Very few undertakings paid excess profits, and most of them had to raise their prices substantially in order to keep receipts above the rising tide of costs, due to increases in wages and the higher cost of coal, stores and repairs. The position of the smaller provincial undertakings, which had practically no industrial load, became especially difficult. Maximum prices are scheduled in every provisional order, and in many cases they proved too low in the abnormal circumstances created by the war. The Statutory Undertakings (Temporary Increase of Charges) Act, 1918, was passed to afford relief. The Board of Trade was empowered, after inquiry into applications for relief, to permit increases in maximum charges sufficient, in the case of companies, to enable three-quarters of the pre-war dividend to be paid, and, in the case of municipalities, to not more than 50% above the pre-war charges, or more than sufficient to enable the undertaking to be carried on without loss.

*Committee on Electricity Supply.*—The proof afforded early in the war of the great national importance of electricity supply led to a series of official investigations into the question of reorganizing the industry on broader and more efficient lines. The Reconstruction Committee (later the Ministry of Reconstruction) formed a Coal Conservation Sub-Committee which discussed the subject chiefly from the standpoint of the more economical use of fuel. The supply industry was also touched upon by the committee formed by the Board of Trade to consider the position of the electrical trades after the war. As the result of a recommendation by this committee a Departmental Committee of the Board of Trade on electric power supply was formed. A report on the same subject was prepared by the Committee of Chairmen of the Advisory Council of the Ministry of Reconstruction. These reports, particularly that of the Board of Trade Committee on electric power supply, led up to the appearance before the House of Commons in the 1919 session of the Electricity (Supply) bill. In its original form the bill provided for the appointment of electricity commissioners and for the constitution of district electricity boards to secure a cheap and abundant supply of electricity by: (a) the acquisition of generating stations, (b) the acquisition or use of main transmission lines of any authorized undertakers, (c) the supply of electricity within their district (including the construction of generating stations, main transmission lines, and other works required for the purpose), and (d) the acquisition of the undertakings or parts of the undertakings of authorized distributors and power companies. At dates to be specified all the public generating stations and main transmission lines in a district were to vest in the board subject to the payment of the "standard price." In the case of municipal undertakings the standard price was defined as one or more annuities sufficient to indemnify the local authority against their liabilities for interest and sinking fund. In the case of a company it was to be "the cost of and incidental to the construction of the generating station or main transmission line, and the acquisition of the site thereby, less depreciation." Boards were to be empowered to borrow for these purposes on terms to be fixed by the electricity commissioners, who were also to be empowered to lend to boards or authorized undertakers, subject to Treasury approval, money up to a total of £25,000,000, if they were satisfied that the boards or undertakers could not otherwise raise the money on reasonable terms. A sum of £20,000,000 was also to be made available out of the consolidated fund to enable the Board of Trade to construct interim works during the first two years. Opposition to the bill was directed chiefly against the compulsory character and operation of joint electricity control, the magnitude

of the sums of public money involved and the inadequacy of the "standard price" in the case of supply companies. In order to meet the first point clauses were introduced by the House of Commons to enable joint electricity authorities to be constituted on a voluntary basis to undertake duties similar in the main to those of district electricity boards. The formation of a board with compulsory powers was retained as an alternative to an authority where voluntary action failed to carry out the intention of the Act.

As the bill did not reach the House of Lords until shortly before the end of the parliamentary session, the contentious parts of the bill were withdrawn by the Government.

**Electricity (Supply) Act, 1919.**—The Electricity (Supply) Act, 1919, was therefore essentially a voluntary measure. It provided for the appointment by the Board of Trade of not more than five electricity commissioners, three of whom were to be selected for practical, commercial, and scientific knowledge and wide business experience, including that of electrical supply. The five commissioners appointed were Sir John Snell (chairman), Mr. W. W. Lackie (formerly chief engineer and manager of the Glasgow Corp. electricity department), Mr. A. Page (formerly general manager of the Clyde Valley Electrical Power Co.); Sir Harry Haward (formerly comptroller of the L.C.C. and Mr. H. Booth, of the Board of Trade. Their general duties are defined in the Act as "promoting, regulating, and supervising the supply of electricity"; and they are empowered to conduct experiments for the improvement of electricity supply or the utilization of fuel or water-power, and to appoint committees to advise them on matters connected with the general improvement and development of the supply of electricity. Their first specific duty was to determine provisionally "electricity districts" for the purposes of the Act and to hold a local inquiry in each suggested area to determine the area finally, and to hear and consider schemes for improving the existing organizations for the supply of electricity. Such schemes might provide for the establishment and incorporation of a district electricity authority representing authorized undertakers in the district, county councils, local authorities, large consumers of electricity, and other interests within the district, and for the exercise by that authority of the powers of the authorized undertakers, and for the transfer to it of any of the undertakings by consent and on terms provided by the scheme. Effect is given to a scheme by its embodiment in an order presented to the Board of Trade for confirmation and, when confirmed with or without modification, laid before Parliament for approval, whereafter it has the effect of an Act.

The duty of a joint electricity authority is to "provide or secure a cheap and abundant supply of electricity within its district," and for that purpose it shall have such powers as may be embodied in the scheme as regards: (a) the supply of electricity within the district (including the construction of generating stations, main transmission lines, and other works), and (b) the acquisition of supply undertakings. No generating station or main transmission line can be established or extended without the consent of the electricity commissioners, except in the case of a private station, which must comply with regulations as to the type of current, frequency, and pressure laid down by the commissioners. Each joint authority is given power to supply electricity within its district except in the area of an authorized distributor or a power company for any save certain specified purposes, unless consent is given, such consent not to be unreasonably withheld. Local authorities are given power to transfer their supply undertakings or their rights of purchase over supply companies' undertakings to joint authorities by agreement. Similar provision is made for the transfer of company undertakings to joint authorities. Under the heading of "Transitory Provisions" the Act enables the Board of Trade, at any time after an electricity district has been provisionally determined and until two years after a joint authority has been established, to carry out interim works, for which purpose the Treasury may issue out of the consolidated fund sums not exceeding £20,000,000 in the aggregate, such works to be vested later in the joint authority on repayment of capital cost and interest. Several amendments to the Electric Lighting Acts are made, notably with regard to overhead lines and wayleaves, all absolute vetoes being abolished. Joint authorities and municipal supply authorities are authorized to provide, let for hire, and connect, but not to manufacture or sell, electrical apparatus.

The Act applies to Scotland and Ireland with slight modifications, and provides that all the powers of the Board of Trade relating to electric supply shall be transferred to the Minister of Transport, to whom the electricity commissioners shall be wholly responsible. (These powers were formally transferred to the Minister of Transport on Jan. 23 1920 by an Order in Council, entitled the Ministry of Transport [Electricity Supply] Order, 1920.) In the 1920 session, and ag. in 1921, the Minister of Transport brought in a bill—the Electricity (Supply) bill—to amend the Act, with the chief object of conferring financial powers on joint electricity authorities. These authorities are to be empowered to borrow on the security of their revenues and property; and authorized undertakers, county and local authorities, and any local authority, company, or person receiving or intending to receive a supply of electricity are to be authorized to lend money, subscribe for securities, guarantee payment of interest, or give financial assistance in any other approved form to the joint authorities. The prices charged by a joint author-

ity are to be so fixed that the receipts shall be sufficient to cover expenditure with such margin as the electricity commissioners may allow; and the commissioners may require such modifications as prices charged by authorized undertakers as will secure that the benefit of any reduction in the cost of electricity to the undertaker or in the capital employed shall accrue to consumers. Clause 14 makes the ordinary period of revision of maximum prices three years (instead of five under the Electric Lighting Acts, 1882 to 1909), and the provisions are extended to local authorities.

In pursuance of Section 5 (1) of the Electricity (Supply) Act, 1919, the electricity commissioners issued, during 1920, notices of the provisional determination of 13 electricity districts, as follows:—(1) Lower Severn; (2) Mid-Lancashire; (3) S.E. Lancashire; (4) W. Riding (Aire and Calder); (5) Mersey and W. Lancashire; (6) N. Wales and Chester; (7) London and Home Counties; (8) N.W. Midlands; (9) N.E. Midlands; (10) S.W. Midlands; (11) E. Midlands; (12) S. Wales; (13) N. Lancashire and S. Cumberland. For the guidance of organizing committees of supply engineers and representatives of local authorities and others interested, the commissioners had previously issued a statement on the procedure to be adopted at local inquiries into the delimitation of areas, and a memorandum setting out the technical and other particulars required in connexion with proposals for the formation of joint authorities. The holding of local inquiries was begun in 1921.

**Growth of Associated Effort.**—Apart from the Electricity (Supply) Act, 1919, and the changes wrought by the war, the most notable feature in the electric supply industry was the growth of representative associations. The municipal undertakings are represented by the Incorporated Municipal Electrical Assn. (founded in 1885); the electric power companies by the Incorporated Association of Electric Power Companies (registered in 1905); and the provisional order companies outside London by the Provincial Electric Supply Committee of the United Kingdom (formed in Jan. 1917). The majority of the metropolitan electric supply companies are represented by the London Electricity Joint Committee (1920), Ltd. and there is also a conference of local authorities owning electric undertakings in Greater London. Similar associated effort has been manifested in other branches of the electrical industry, and the Institution of Electrical Engineers has provided a common platform upon which all sections could meet for the discussion of legislative and other problems. In June 1919 the British Electrical Development Assn. (director and secretary, Mr. J. W. Bunschamp) was formed (incorporated Jan. 17 1920) to further the interests of electrical progress by means of organized propaganda. This association is supported by the Institution of Electrical Engineers, the main associations representing the electricity supply industry, the British Electrical and Allied Manufacturers' Assn., the Electrical Contractors' Assn., and kindred electrical associations. During 1921 the British Electrical Development Assn. submitted to the electricity commissioners a lengthy memorandum on the subject of tariffs for electric supply undertakings. Multi-part tariffs, in which the flat rate per unit is replaced by a fixed charge intended to cover the capital cost of service and by a running charge, were strongly advocated as a means of stimulating the use of electricity for cooking, heating, and other purposes apart from lighting, and also of putting the finance of supply undertakings on a more satisfactory footing in view of the abnormal increases in the cost of plant, fuel, and labour brought about by the war. The commissioners were asked to include in the Electricity (Supply) bill a clause authorizing multi-part tariffs. At present such tariffs cannot be enforced, as the undertakings must offer, at least as an alternative, current at a flat rate with a maximum charge.

**Joint Industrial Councils.**—For the purposes of "Whitley" Councils to deal with questions of wages and conditions of labour in electric supply undertakings, the country has been divided into 13 districts, each with a district council representing employers and employed. The district councils are in turn represented on a national joint industrial council for the electricity supply industry (formed May 1919). There was also instituted, on Dec. 12 1919, a national joint board of employers and members of staffs for the electricity supply industry, to deal with all matters affecting salaries and conditions of employment of technical engineers. This board proposed to set up 13 district joint boards corresponding to those constituted by the national joint industrial council mentioned above.

**Statistics.**—The total British capital involved in 1920 by 334 electricity supply companies (this being the number for which returns were available) is given in Garcke's *Manual of Electrical Undertakings and Directory*, Vol. 24, as £72,812,872. In 1910 the corresponding figure for 239 companies was £47,047,847. Losses authorized to be raised by municipalities for electricity amounted to £70,836,470 (308 undertakings) in 1920 and to £42,617,969 in 1910 (316 undertakings). Over the same period the average dividend (on the whole of the capital) of electricity supply companies rose from 4.32% to 5.58%, the major part of this increase being due to the ordinary shares, which returned 6.51% in 1920 as compared with 3.91% in 1910. During 1920 the municipal undertakings showed a trading balance of £5,828,432. After providing for special charges, interest on loans, sinking fund, and depreciation and reserve, there was among the more successful undertakings an aggregate surplus of £621,385 and among the others a deficit of £260,850.



The total capacity of plant installed by companies and municipalities was, so far as could be definitely ascertained, 2,546,000 K.W. in 1920, with a load connected (equivalent 30-watt lamps) of 144,274,800, and an aggregate maximum load of 1,372,548 K.W. The Board of Trade units of electricity are recorded for 1920 as 3,086,382,748, and in 1910 as 1,027,420,254.

Further information on the above subjects may be gathered from the following publications: "Electric Power Supply during the Great War" (Part I.) by (Sir) A. B. Gridley and A. H. Human. (*Jour. Inst. Elec. Engrs.*, vol. lvii., No. 282, May 1919); *Interim Report of the Coal Conservation Sub-Committee of the Reconstruction Committee on Electric Power Supply in Great Britain* (Cd. 8,880); *Report of the Board of Trade Committee on the Electrical Trades after the War* (Cd. 9,072); *Report of the Board of Trade Committee on Electric Power Supply* (Cd. 9,062); *Report of the Committee of Chairmen of the Advisory Council of the Ministry of Reconstruction on Electric Power Supply* (Cd. 93); *The Manual of Electrical Undertakings*, vols. xiii-xiv. (A. G. W.)

**UNITED STATES.**—The decade 1910-20, perhaps not so rich as its predecessor in fundamental electrical invention, showed so greatly increased a demand for electric current that much effort was applied to improving methods of production and supply. In many sections of the country all sources of water-power nearby were already employed so that it was necessary to transmit power two and three hundred miles. The highest voltages used in 1910 would be too low to be economical for such distances; during 1910-20 the use of transmission voltages in excess of 100,000 became fairly common; in 1921 220,000-volt lines were being completed. Larger generating units also became necessary. These were in operation in 1921 35,000-K.W. water-wheel units, and 50,000-K.W. units were to be used in Canada in 1922. Steam turbines of the multiple-unit type as large as 72,000 H.P. were operating in New York City and single-unit types up to 35,000 H.P. were operating successfully.

Because of the better light and smaller consumption of the tungsten lamp, which was made practicable by the discovery of a process for drawing tungsten wire, the demand for electric current grew rapidly. This lamp, by using less current, reduced the expenditure of every establishment using electric light, and it became necessary to develop a commercial organization to sell service. By 1921 virtually every electric light and power company maintained a selling organization. Much of the new demand was due to the war. The orders of the Allies for munitions in and after 1915 found the factories of North America ill-equipped to undertake so sudden an increase of production. It was quicker to buy electric power than to procure and install additional generating equipment. Then, later, a serious coal shortage made it apparent throughout the country that a central power-distributing organization was more economical and reliable than a number of small isolated plants. Added to the industrial demand thus suddenly thrust upon the power companies came a heavy demand from households for current for appliances. Domestic had been enticed from service by the munitions plants and electric labour-saving devices replaced them.

There were in 1921 nearly 7,000,000 homes in the United States wired for electric service, served by 5,600 electric light and power companies, the output of which for that year was expected to be about 42,000,000,000 K.W.-hours. From the sale of this current \$1,050,000,000 would be obtained. The capital invested in these plants then amounted in round numbers to \$4,500,000,000. The growth of retail outlets *per capita* for electrical merchandise increased nearly 400% during 1910-20, and the output of central power plants nearly 300%.

In spite of the lower consumption of current by the tungsten lamp the prices for electric current decreased steadily until 1916, when higher wages and costs of materials offset economies of efficient operation. About that time a number of supply companies initiated what is known as the "coal clause" in their contracts with consumers, under which the rate varied in a fixed ratio to the fluctuating price of coal. By the end of 1921, however, these clauses had begun to disappear. Household rates were not raised during the war, but later there were many increases. There was some urging of the London sliding scale of rates but in 1921 only two or three companies were using it. In fact, while during the first ten years of the century a great variety of rate-schedules was proposed and put into use, the second decade was free, comparatively, from such activity except perhaps for a form of household schedule which based the rate on the number and type of rooms plus a charge for current.

State regulation, which had appeared in a few states before 1910, by 1921 was found in nearly all states, and any attempt to substitute local regulation was opposed bitterly by the power companies. State regulation did more than anything else to free electricity supply from political interference. As a result term franchises were fast disappearing and were being replaced by indeterminate franchises.

No review of the decade's progress of electricity supply would be complete without reference to the great expansion of syndicate operation and management. Through the control by one company, usually known as a holding company, of numerous properties, a great saving was made. Central organizations have applied to small properties better engineering and management than they otherwise could have had. This also resulted in the discounting of small uneconomical plants and the substitution of large unified systems supplying many communities.

The advantages derived from unified systems became so significant that "super-power" projects began to be agitated. The United States Government became interested and an appropriation was made for an investigation of the power resources of the industrial region of the Atlantic seaboard, from Washington to Boston, under the auspices of the U.S. Geological Survey. This report was not yet published in Oct. 1921. It was known, however, that a vast network fed by a number of "super-power" plants would be recommended. Other surveys were being made by those locally interested in the South and in the North-West.

A little more than half of the current sold by power companies in the United States is generated by water-power. The development of the water-power resources of the country, however, was greatly retarded during 1910-20 by the threat of unfavourable Federal legislation. Congress considered for twelve years a water-power bill which was finally passed in 1920. Since its passage there has been a water-power stampede similar in many ways to the 1849 gold stampede to California. Applications were on file in 1921 for more than 51,000,000 H.P. and preliminary permits and licences had been granted to develop 2,255,696 H.P. The bill creates a Federal water-power commission, comprising three cabinet officers, the Secretaries of War, Agriculture and the Interior, to which is given authority over all matters over which the Federal Government has jurisdiction, pertaining to the development of water-powers in navigable streams, on the public domain and in the national forests.

The features of the bill are: (1) the erection of a commission (The Federal Power Commission); (2) the granting of a 50-year lease; and (3) the ability of the Government to resume control of the project on the payment of just compensation at the termination of the lease. Priority is given to national, state and municipal governments. On the Colorado river alone one company was planning to develop between three and four million H.P. of electrical energy.

In order further to assure continuity and reliability of central service, and also to make certain economies possible, the interconnection of large power systems was introduced. One such system extends along the Gulf states, from Alabama to Georgia, through the Carolinas and into Tennessee. Another interconnects most of the important New England systems, and a third covers the great industrial region of Pennsylvania. California is connected from end to end, and the Rocky Mountain states are similarly linked. In addition there are other important but less extensive interconnections; it would be possible by spanning a few gaps to interconnect almost the whole country.

Embraced in these interconnections are certain large industrial plants. They interchange current with the public utilities under an arrangement beneficial to both. The tendency, however, is unmistakably toward service of all manufacturing plants by central stations. The only reason this has not gone further is that the power companies during 1915-21 were generating to their full capacity.

A survey made by the *Electrical World* of New York City shows that in 1920 there were 326,840 consumers of electric power in the United States. These were divided by sections as follows: New England, 35,400; Middle Atlantic, 50,950; South Atlantic, 19,200; North Central, 133,730; South Central, 22,370; Mountain, 10,690; and Pacific, 54,600.

Seventy-one central power companies had in 1921 an output of more than a hundred million K.W.-hrs. and nine in excess of a thousand million K.W.-hrs. The three companies having the largest output were in 1920 the Niagara Falls (N.Y.) Power Co., 2,228,326,064 K.W.-hrs.; the Commonwealth Edison Co., Chicago, Ill., 1,883,570,000 K.W.-hrs.; and the Pacific Gas & Electric Co., San Francisco, Cal., 1,475,678,673 K.W.-hrs.

Municipal ownership sustained a great setback during the war because high costs of production added too much to city budgets. As a result a great many municipal plants went out of existence, their service being replaced by that of large transmission systems. Just before the war, however, there were some important additions to municipal operation, particularly in California and Ohio.

Another activity curtailed by the war was the organized sale of electric ranges. The provision by central stations of current for cooking before the war was becoming extremely important. Many cities had established a special range rate as low as 3 cents per K.W.-hour. High first cost, however, interrupted this activity, but in 1921 it seemed to be reviving. The practice in street lighting had been that the public utility service should own and maintain the lighting



system, but during 1910-20 there was a marked tendency toward municipal ownership of the system. The energy is purchased at the substation in bulk.

The latest statistics available for Canada are as of Jan. 1 1919 and show 795 central electric power stations in which the capital invested was \$401,942,402. The total revenue from the sale of power was \$53,549,133, for lighting purposes \$16,952,512, and for all other purposes \$36,596,621. The generating capacity at that time was 1,433,722 kva.

In Canada private operation seemed to be gradually giving way to provincial operation. The largest single system was that of the Ontario Hydro Electric Power Commission which with its latest acquisitions supplied about 1,000,000 horse-power. In 1921 this, the largest single electrical system in the world, developed under the direction of Sir Adam Beck, was being copied in other parts of Canada and was finding admirers in different parts of the United States, particularly California, where a similar system was proposed. The provincial systems were equivalent in effect to municipal control. The domestic rates were very low and as a result electricity was used quite extensively in the homes. A rate as low as one cent a K.W.-hr. was charged for electric cooking. (S. B. W.)

**ELECTROCHEMISTRY** (see 9.208) and **ELECTROMETALLURGY** (see 9.232).—Although these subjects are essentially connected, it will be convenient here to group separately the principal headings in each case under which notable advances had been made during 1910-21.

I. ELECTROCHEMISTRY

**Alkalies and Chlorine.**—The electrolytic methods of producing alkalies and chlorine by the decomposition of brine made remarkable progress during the period 1911-20. Electrolytic alkali works are now being operated in all the leading manufacturing countries where the raw materials of the industry are found; and even those who control the operation of the old Le Blanc process of alkali manufacture in the United Kingdom have found themselves at last compelled, by the force of circumstances and by the changing conditions of the trade and industry, to adopt the newer method of decomposing salt.

The cells now being operated industrially may be classified as diaphragm and non-diaphragm cells. In the former class, a porous diaphragm, composed of cement, asbestos or other material unacted upon by the electrolyte (or by the ions produced by the electrolysis), is employed to separate the cell into two or more compartments, and in this way the chlorine liberated at the anode is to a large extent prevented from taking part in secondary reactions with the sodium or potassium hydrate formed at the cathode.

The "Elektron," Hargreaves-Bird, Outhenin-Chalandre, Basel, Billiter-Siemens, Nelson, Allen-Moore, Gibbs and Townsend cells are all of this type, the chief difference between them being in the construction or design of the diaphragm and in the arrangements made for withdrawing the sodium-hydrate solution from the cathode compartment of the cell, before it has had time to be decomposed by the electric current. The defects of all diaphragm cells are the higher voltage required per cell, and the increased costs of maintenance, due to the lack of durability on the part of the diaphragm.

For these reasons the other class—namely, non-diaphragm cells—always attracted the electro-chemist, and many of these have been patented and tried. Only two types have survived industrial trial—namely, (1) the Castner-Kellner, Whiting and Solvay cells, which employ a moving mercury electrode in the cathode compartment of the cell, and thus produce an amalgam of sodium which can be removed from the cell before it is decomposed; and (2) the "bell" type of gravity cell, which makes use of the different specific gravities of the brine, and of the newly-formed sodium or potassium hydrate solution; in order to effect a separation of the two. The Aussig "bell" cell and the Billiter-Leykam cell are the only two representatives of this class in actual operation; the Richardson and Holland cell, which was tried on a large scale at St. Helens in the years 1896-1900, having proved a failure.

The attempts to use molten lead in place of the more expensive mercury in the liquid or moving electrode cells have also failed, after trial upon an industrial scale; the wear and tear of the cell structure, and the fire dangers with this type of cell, having caused the suspension of operation of the Hulin cell at Les Clavaux in France, and of the Acker cell at Niagara Falls in America. The works where the latter cell and process were operated was, in fact, burnt down some few years ago, and has not been rebuilt.

The World War caused a considerable increase in the number and capacity of the works for the electrolytic decomposition of brine, liquid chlorine being required in very large amounts by the military authorities, not only for gas-warfare but also for sterilizing water supplies. The U.S. Government in 1918 planned and erected a large works of this type at the Edgewood Arsenal, equipping it with 3,552 cells of the Nelson (diaphragm) type in order to provide the army authorities with all the liquid chlorine they required. At the

date of the Armistice, this plant could have produced 700 tons chlorine gas per day of 24 hours, if worked to the full.

The figures in Table I are drawn from the most reliable sources, and give a useful summary of the comparative efficiencies of the various cells as operated in 1921, and the strength of the caustic-soda solution they produce. It will be noticed that the cells with the highest current and energy efficiencies give the weakest solution of sodium hydrate at the cathode, and that in order to obtain a fairly concentrated cathode liquor, one must sacrifice to some extent the electrical efficiency of the process.

TABLE I.  
Comparative Efficiencies of the Leading Types of Electrolytic Alkali and Chlorine Cells.  
(Allmond's and Kershaw's Figures.)

Type of Cell	Cathode Efficiency %	Energy Efficiency %	Voltage	Concentration—Grammes per litre NaOH	K.W.-hr. per Kgm. NaOH
Finlay	98	75	3.0	80	2.0
Billiter-Siemens	92	68	3.1	120	2.3
Vorce	97	62	3.6	—	2.5
Billiter-Leykam	95	59	3.7	140	2.6
Allen-Moore	91	59	3.5	100	2.6
Whiting	92	53	4.0	200	2.9
Hargreaves-Bird	85	—	3.7	120	—
Nelson	86	53	3.8	120	2.9
Castner (rocking-cell)	92	50	4.2	200	3.1
Kellner (C. Anodes)	95	49	4.3	220	3.1
Bell-jar (Aussig)	85	49	4.0	80	3.1
Griesheim (Carbon)	70-80	45-51	3.6	60	3.0-3.4
Wilderman	97	45	5.0	220	3.4
Kellner (Pt. Anodes)	97	45	5.0	220	3.4
Townsend	91	45	4.8	160	3.4
Griesheim (Magnetite)	70-80	40-46	4.0	60	3.3-3.4
Outhenin-Chalandre	66	41	3.7	80	3.7
Theoretical figures	100	100	2.3	—	1.54

\*This cell produces Na<sub>2</sub>CO<sub>3</sub>—not NaOH.

To produce one ton of solid caustic soda from a solution containing only 80 grammes per litre of NaOH (the strength produced by the Finlay cell) means the evaporation of over 10 tons of water; whereas with a cathode liquor containing 240 grammes NaOH per litre (the strength produced by the mercury cell processes), only one-half this weight of water will have to be evaporated to obtain the solid product, and the fuel consumption will thus be reduced 50%.

The answer to the question which cell is the best for the production of solid caustic soda or potash depends, therefore, largely upon its relative costs of electric power and of solid fuel in the locality where the cell is to be operated. The Whiting, Castner-Kellner, and Wilderman mercury cells, as shown by the table, all yield cathode liquors of fairly high concentration—200 to 240 grammes NaOH per litre. If the cost of mercury were not so high, they would be generally adopted for the production of caustic hydrates and chlorine, in spite of their rather low energy efficiencies, since they also yield a specially pure product at both the anode and cathode.

Of the diaphragm types of cell, the Billiter-Siemens, Billiter-Leykam, Townsend and Nelson cells all yield a liquor containing 120-160 grammes NaOH per litre, and, therefore, come next to the mercury cells. No figures for the concentration of caustic liquor or the efficiency of the Gibbs cell are available.

The Aussig bell, Griesheim, and Outhenin-Chalandre cells, on the other hand, yield a liquor containing only 60-80 grammes NaOH (or under) per litre, and in view of the amount of fuel required to produce solid caustic from such weak liquor, it is surprising that these cells have attained so wide a use on the continent of Europe.

**Chlorates, Perchlorates and Persalts generally.**—The electrolytic method of manufacture of chlorates and perchlorates of potash and soda was in 1921 being worked in all countries where cheap electric power was available, the most notable works being that of Messrs. Corbin & Cie, at Chedde, in the Haute Savoie department of France, and at Trollhattan in Sweden. The cells used at Chedde are constructed of cement, and are arranged in terraces so that the electrolyte flows through them by gravity. Very thin sheets of platinum-foil fixed in ebonite frames act as bipolar electrodes in series, the number of electrodes per cell and of cells in a circuit being arranged to suit the voltage of the generators. The electrolyte used is a 25 to 30% solution of KCl or NaCl; a current density of 100 to 200 amperes per sq. ft. of anode surface is employed. This leads to a high E.M.F.

being required, even though the electrolyte is heated to 70° C. and the bipolar electrodes are only  $\frac{1}{2}$  in. apart.

When potassium chloride is employed as electrolyte, the chlorate can be easily separated by crystallization on cooling from the mother-liquor containing the unaltered chloride; but when sodium chlorate is being produced, different treatment is required to obtain separation of the chloride and chlorate, since the sodium salt is much more soluble than potassium chlorate. The current efficiency when producing either sodium or potassium chlorate can be raised to 90% when the process is well-managed; and the conversion of chloride into chlorate is completed in one operation.

Were it not for the fact that no satisfactory substitute for platinum can be found as electrode material for chlorate cells, and that consequently the capital costs of the cell installation are very high, the electrolytic process of chlorate manufacture would before now have quite supplanted the older chemical process, which is still operated in the few places where the Le Blanc process survives.

The conditions required in order to obtain perchlorates, and other highly oxidized salts such as persulphates, in an electrolytic cell are:—(1) Insoluble electrodes; (2) a high current density at the anode; (3) the prevention of any reducing action by the hydrogen liberated at the cathode. This latter condition is obtained, either by the use of a diaphragm between the two compartments of the cell, or by the employment of salts, such as chromates or cyanides, which serve to suppress the cathodic reduction.

According to the most reliable information, perchlorates are now produced by electrolyzing a concentrated solution of sodium chlorate, containing 600–700 grammes per litre of this salt, at a temperature of 10° to 30° C. with a current density of 400–500 amperes per sq. foot. When the chlorate content of the electrolyte falls below 100 grammes per litre, the resistance of the bath increases considerably, and the temperature rises to 45° to 50° C. with a reduction of the current density to 70 amperes per sq. foot. If the chlorate concentration of the electrolyte falls below 10 grammes per litre, much ozone is given off, and the evolution of this gas may increase to such an extent that the workmen in the cell rooms are affected injuriously. Under normal conditions, however, the conversion of the chlorate into perchlorate proceeds without evolution of ozone, and with an average efficiency of 85%; the power required to produce 1 kgm. of sodium perchlorate from chlorate being 3½ K.W.-hrs. As the sodium salt is deliquescent it is not worked up as such, but the potassium salt is precipitated by adding potassium chloride. The ammonium salt is prepared similarly, by treating the sodium perchlorate solution with ammonium chloride; or the ammonium salt can be produced by starting with calcium chloride, and by converting this by successive stages of anodic oxidation into calcium perchlorate, which is finally decomposed by the ammonium chloride, to yield ammonium perchlorate.

Sodium perborate is produced in a similar manner, by electrolyzing solutions of sodium borate; and as this salt has found a wide application in the arts and industries, some further details of its method of manufacture may be given here. The process employed is based on the use of a mixed solution of sodium borate and an alkaline carbonate as electrolyte, with the addition of some substance which will coat the cathode with a colloidal or other deposit that lowers the reducing action of any hydrogen liberated at this point; chromic acid being most suitable for this purpose. During the electrolysis, the strength of the alkali carbonate solution must be maintained, preferably by the presence of the solid salt; but towards the end of the electrolysis this solid carbonate can be allowed to go into solution. Sodium borate must also be present in the solid state during the electrolysis, in order to keep up the concentration of the electrolyte. The presence of magnesium silicate, stannic acid and alkali bicarbonates is said to accelerate the conversion of the borate into the persalt. The latest theory of the conversion is, that perborate is first formed, and that this salt then reacts with the sodium borate to yield sodium perborate during the course of the electrolysis; in any case, for the success of this method of production, the presence of solid perborate in the cell appears to be necessary.

**Persulphates and Hydrogen Peroxide.**—Persulphates are another class of highly oxidized salts which are finding a wide application in the arts and industries, especially in photography, and here again the electrolytic method of production is the simplest and most efficient.

As a practical matter, in judging the comparative merits of the chemical and electrolytic methods for producing these persalts and compounds, it is necessary to note that the cost of the electric current, when producing pure chemicals of this type, is not a very serious item in the total cost of production. As a rule, the desired salt can be produced in a pure state by one simple operation in the electrolytic cell or bath; and this of course is a factor in the economy of the electrolytic methods which must not be overlooked in judging the comparative cost of electrolytic and chemical methods of manufacture of what are usually classed as "fine" chemicals.

The method of producing persulphates in the electrolytic cell is based upon the discharge of  $SO_4$  ions at the anode of the cell. The conditions required to effect this discharge are the same as in the case of the production of perchlorates:—(a) A low temperature; (b) a high current density with a smooth platinum anode; (c) an acid solution, or one at least free from alkali.

When employing a diaphragm type of cell, a concentrated solution of ammonium sulphate is employed in the anode compartment of the cell and sulphuric acid of medium strength in the cathode compartment. Smooth platinum must be employed as anode material, but lead can be employed as cathode; and the cathodes may be of much larger surface area than the anode.

Two methods have been employed for the production of hydrogen peroxide by electrolysis: the one based upon the use of persulphuric acid as intermediate product, and the other upon the use of potassium or ammonium persulphate. The conditions which necessarily should be observed in the first method are as follows:—(1) The density of the sulphuric acid should be between 1.35 and 1.50; (2) the electrolysis should be carried out as rapidly as possible; (3) the current density should be high, about 950 amperes per sq. ft.; (4) the solution must be cooled, or a hollow anode may be used, cooled internally by the circulation of water at 15° to 20° C.

**Hypochlorites.**—It is noteworthy that Charles Watt, in his very remarkable patent No. 13,755 of 1851, clearly explained all the conditions which must be maintained in the cell in order to produce hypochlorites by the electrolytic decomposition of sodium or potassium chloride solutions. The advances that have been made since that year have been simply in the form and design of the apparatus used for carrying out the electrolytic method. The leading features of the modern cells, designed specially for hypochlorite production, are, however, very similar. They all possess graphite or platinum electrodes, placed close together so that the chlorine liberated at the anode reacts at once with the alkaline hydrate formed at the cathode; and they possess also some mechanism for promoting the rapid circulation and cooling of the electrolyte, in order to avoid the formation of chlorate. The three leading types of electrolyzer, for the production of bleaching solutions, are:—(1) the Haas and Oettel (or "Manchester," as it is now called), (2) the Kellner, and (3) the Mather and Platt.

The latest form of the Manchester electrolyzer, as operated in 1921, makes use of carbon as electrode material, and of the liberation of hydrogen at the cathode, to effect automatic circulation and mixing of the liquid. The inner or working cell is a rectangular stoneware tank, divided by the carbons into 30 narrow compartments or cells. The first and last carbons of the set form the main electrodes of the cell; the intervening carbons act as secondary electrodes, i.e. as anodes on the one face and cathodes on the other. This electrolyzer holds 750 litres of 15% brine, and takes 75 to 80 amperes at 110 volts. Its output in 10 hours equals 10.5 kgm. of active chlorine.

The Kellner electrolyzer consists of a shallow stoneware tank, divided into a large number of narrow cells by means of vertical glass plates, so arranged that the electrolyte is obliged to take a zig-zag course in its passage through the electrolyzer. The electrodes are formed of platinum-iridium gauze and are arranged horizontally, with the anodes below the cathodes, so that the chlorine liberated at the former may be absorbed by the supernatant liquid. This electrolyzer is constructed usually to take a current at 110 volts, and has only two terminal electrodes; all the intervening electrodes function as secondary electrodes. The Kellner electrolyzer holds 820 litres of brine testing 15%, and requires a 90-ampere current at 110 volts. Its output in 10 hours equals 15.0 kgm.

The Mather and Platt electrolyzer is constructed on the filterpress principle, with a trough for supply of the brine running along the top of the frame. The frame holds 22 separate cells fixed transversely, and the brine feeds these through a perforated tray in fine streams which break up into drops on falling and thus prevent current leakage. The 22 cells forming one electrolyzer are placed in one frame, and are connected in series. They take a current of 250 amperes at 110 volts. The salt consumption is 10.3 lb. salt, and the power consumption is 2½ K.W.-hrs. per lb. of available chlorine produced.

In recent years the direct production of hypochlorites and bleaching solutions by electrolysis has been curtailed. It has been found more economical to use the chlorine gas obtained from the electrolytic alkali cells for this purpose, and to absorb this either in the milk of lime, or in the hydrate solution produced at the cathode, the absorption taking place in a separate vessel outside the cell.

**Oxygen and Hydrogen.**—The electrolysis of acidulated water to show that it is composed of two gases, and the recombination of these gases by explosion to form drops of water, is one of the oldest of chemical lecture-table experiments; and it is not surprising, therefore, that cells for producing oxygen and hydrogen upon a commercial scale, by electrolytic methods, have been

patented and operated. The Schoop, Garuti, and Schukert cells were the best known of these. The first-named used sulphuric acid, while the remaining two employed caustic potash as electrolyte; the power consumption being 5.9 and 4.1 K.W.-hrs. respectively per cubic metre of the mixed gases.

In recent years, however, oxygen has been more economically obtained by the fractional distillation of liquid air, which can now be produced very cheaply; and hydrogen is obtained either from electrolytic alkali cells (as a waste product), or from blue water gas, by improvements of the old iron-contact process. By means of this, the carbon monoxide is first oxidized to CO<sub>2</sub> and is then removed from the gas mixture by absorption. The electrolytic production of hydrogen and oxygen is, therefore, now carried on in only a few localities, and for the few industries where both gases are required for immediate use in their relative combining proportions, as in the oxyhydrogen blowpipe.

**Ozone.**—Since most of the early patents for ozone apparatus have lapsed by efflux of time, the general type of apparatus for the production of ozonized air, as placed on the market in 1921 has been standardized.

Ozonizers now usually consist of an inner cylinder of sheet copper or aluminium, connected to the high-tension side of the transformer and well insulated, and an outer metal cylinder which is connected to the casing of the ozonizer, and is kept at zero or earth-potential. The two cylinders are separated by a glass tube through which the air is passed, and the silent discharge takes place in the annular air-space between the two metal sheets. The outer sheet of metal is water-cooled, and thick glass windows at each end of the ozonizer tube enable the operator to see if the discharge through the air-gap is occurring in a proper manner. Alternating currents with frequencies up to 60 cycles are employed for these installations; and the practical limit of E.M.F. has been found to be 10,000 to 12,000 volts.

Ozonized air has been employed for bleaching wax, textiles, paper-pulp and sponges; for the sterilization of air and food; and also for the acceleration of the drying and hardening processes in paints and varnishes, and for the rapid oxidation of oils.

**Organic Products.**—It is difficult to obtain any information as to the extent to which electrolytic methods have been and are being applied in 1921 outside the laboratory in the field of organic chemistry; but there is reason to believe that in Germany considerable progress had been made in this direction, and that not only bromoform and iodoform but also anthraquinone and other organic products have been produced electrolytically.

**Phosphorus.**—At one time the electrothermal process for the production of phosphorus from bone-ash was being employed at Oldbury, near Birmingham, and at Niagara Falls, and an output of 30 tons per month was reported to have been attained. The bone-ash was mixed with silicic acid (sand) and carbon, and the mixture was then heated to between 1300° and 1500°C. The phosphorus commenced to distil over at 1150°C. and was all expelled from the mixture before a temperature of 1450°C. was reached. According to Hempel, this method of manufacture had also been used in Germany, gas-tight iron cylinders lined with fire-clay being used as the furnaces in which the raw materials were heated. The use of silicic acid (or sand) to produce a calcium-silicate slag, it must be noted, is only practicable with methods of reducing calcium phosphate which render this slag quite fluid, a result that can be attained only by aid of electric heat. Molten calcium silicate is also very corrosive, and the advantage of the internal system of heating is that the outer walls of the furnace can be artificially cooled, and a layer of cold slag can be formed to protect the refractory lining from the action of the slag.

A process very similar to that described above, for the manufacture of phosphorus, was brought out in America and patented some years ago in the name of Machalske. The furnace used for operating this process possessed an internal chamber, measuring 12 in. x 18 in. and was provided with a carbon bottom, sides of calcined magnesite, and a cover of fire-clay and red brick. Two electrodes, each 8 ft. in length by 4 in. in diameter, passed through holes in the cover. With electric power at 3 cents per e.h.p.-hr., Machalske claimed that yellow phosphorus could be produced by this method at a total cost of 7 cents per pound.

From 80% to 92% of the phosphorus can be recovered by this method of manufacture; the balance remains in the furnace or retort as calcium silico-phosphate, and it cannot be expelled by any increase of the temperature.

## II: ELECTROMETALLURGY

**Aluminium.**—There were no discoveries or marked advances during the period 1910–20 in the development of new sources of aluminium, and the mineral bauxite remains the chief raw material of the industry. The increased demand for bauxite, however, has led to several new deposits being opened up and worked, and although none of these equal in purity the French bauxite deposits, the mineral has been found to be much more widely distributed over the world than was at one time supposed. With the aim of reducing the cost, numerous attempts have been made to dispense with the preliminary purification of the alumina (see 1.767–770) and to operate the baths with the raw bauxite, but these so far have not proved successful. In time this improvement in the electrolytic process and reduction in cost of aluminium manufacture will no doubt be achieved.

The world's production of bauxite in recent years is given in Table I, which is taken from a pamphlet published in 1921 by the Imperial Resources Bureau. As regards alternative sources of supply, silicate of aluminium or clay is one of the most widely distributed materials which occur in the crust of the earth. Weaver, a recent Canadian patent (No. 190,054 of 1919), proposes to open up this source of aluminium and its salts by treating the clay with chlorine in the presence of carbon. This leads to the formation of AlCl<sub>3</sub>, SiCl<sub>4</sub> and CO, and with cheap supplies of liquid chlorine the method might be practicable. The chlorides are separated, and the metal is extracted by the electrolytic method described below. Whether this suggested process of using AlCl<sub>3</sub> in place of Al<sub>2</sub>O<sub>3</sub> as raw material for the aluminium industry will prove successful remains for the future to disclose.

**Production and Output.**—The electrolytic process by which aluminium is produced from alumina, as worked in 1921, differed but little from that by which Heroult, at Neuhausen in Switzerland, and Hall, at New Kensington in America, first started the manufacture upon an industrial scale in 1889. The production, however, is now concentrated in the hands of a small group of powerful companies.

As regards the growth of the industry, the figures in Table II, taken from the pamphlet already referred to, indicate very clearly the remarkable expansion which has occurred in the manufacture during the period 1910–20. Compared with the figures compiled by J. B. C. Kershaw some years previously for the period 1893–9, its expansion of the industry becomes even more striking:

	1893	1894	1895	1896	1897	1898	1899
Total World Output (tons)	713	1,057	1,129	1,755	3,327	3,953	5,489

In twenty years, therefore, the world's output of aluminium had increased from 5,000 to 150,000 tons, and the metal had come to rank 4th in the list of nonferrous metals, when judged by the standard of consumption; for only copper, zinc and lead are employed in larger amounts in the arts and industries. The remarkable increase in production which marked the war period was of course due to war requirements; aluminium being used in enormous amounts not only in the powdered form for paints, and as an ingredient of certain forms of explosive (such as "ammonal"), and of pyrotechnical materials, but also being employed, either as pure metal or in the alloyed state, for the construction of airships, aeroplanes, motor-cars, fuses, bombs, radiators and many forms of measuring instruments. The close of the war occasioned, therefore, a very considerable drop in the demand for the metal—but there is little doubt that later the demand for aluminium in the arts and industries would more than absorb the production of the increased plant.

As regards the localities and works where aluminium is now produced, these are in every case operated by water-power, and the names of the companies and locations of the works are as follows—

### United Kingdom.

British Aluminium Co.—Foyers and Kintlochleven, Scotland (Sasfjord, Vigeland, Norway).  
Aluminium Corporation Ltd.—Dolgarrog, North Wales.

### France.

Soc. Electrometallurgique française.—Le Praz, Gardanne.  
Compagnie des Produits chimiques d'Alsais.—Calypso, St. Jean le Mauterme, St. Felix.

### Switzerland, Germany and Austria.

Aluminium Industrie Aktien-Gesellschaft.—Neuhausen, Rheinfelden, Lend Gastein.

### United States of America and Canada.

Aluminium Co. of America.—Niagara Falls, Massena, Shawinigan Falls.

Italy and Norway also possess aluminium works, and during the war two or three factories were started in the highlands of Bavaria for the production of the metal, by the Allgemeine Electricitäts Gesellschaft, of Berlin. The figures given in Table II show that during the last year of the war Germany produced 25,000 tons of aluminium, and was second only to the United States in her output

of this metal; while Norway and Switzerland came next in producing capacity, with 15,000 tons to their credit.

As regards further development of the producing capacity of the works located in the United Kingdom, the British Aluminium Co., which had already developed 25,000 H.P. from water-power at Foyers and Kinlochleven in Scotland, was in 1921 seeking to obtain the necessary parliamentary sanction for developing the much greater water-power of the Lochaber district of Inverness-shire.

Concerning the use of aluminium chloride in place of the oxide for the electrolytic bath, Weaver, in U.S. patent No. 1,297,946 of March 1919, states that if aluminium chloride be fed into a bath containing sodium and aluminium chlorides in the molten condition, at such a rate that the molten chloride is replaced as fast as it is decomposed by the current, the process can be made a continuous one; and the aluminium and chlorine, which are the two products of the electrolysis, can be separately drawn off. An apparatus is described in the patent, by which this method can be carried out.

The application of aluminium has grown enormously in recent years. One very large and increasing field of the metal is in the electrical trade, in which it is used for transmission lines, bus bars, field coils and windings, etc., etc. Its applications in the motor-car industry are well known, for not only is it employed in sheet form for gear and crank cases and for body work, but it is also employed largely for engine castings. Aluminium is being used to an ever-increasing extent in the chemical, brewing, sugar-refining, margarine, dyeing and soap industries, and the manufacture of cooking utensils affords another large outlet for the metal.

carbide are recognized, and the attempts to apply carborundum wheels to the grinding and finishing of fine steel goods have ceased, the artificial abrasive industry is on a very sound footing.

Silicon carbide is intensely hard and very brittle, and it is most suitable for grinding and finishing similar materials such as cast iron and marble, and for the finishing of leather goods; while artificial corundum has taken the place of the natural variety (emery) where it has been found more suitable than carborundum.

**Brass and Bronze.**—There have been many attempts in the past to apply electric methods of heating and refining to the melting and casting of brass. Until recent years none of these attempts were successful, but during the World War a large amount of experimental work was carried out in America with various types of electric furnace, and the difficulties that surround the electric melting and refining of brass and bronze appeared in 1921 to have been overcome.

At the commencement of the World War, there were, according to H. W. Gillett of the U.S.A. Bureau of Mines, no electrically heated brass furnaces in commercial operation in the United States. By the end of 1919 there were 40 American firms using or installing such furnaces, and over 100 of these were in operation. One brass-rolling mill is stated to have installed 30 furnaces, though these were chiefly of small capacity; one smelting

TABLE I.  
World's Production of Bauxite.  
(Long tons)

	1913	1914	1915	1916	1917	1918	1919
United Kingdom . . . . .	6,055	8,286	11,723	10,329	14,724	9,589	9,221
British Guiana . . . . .	—	—	—	—	2,037	4,199	—
India . . . . .	1,184	514	876	750	1,363	1,192	1,682
France . . . . .	304,323	—	55,614	104,493	118,973	—	160,820
Hungary . . . . .	—	—	58,118	—	—	—	—
Italy . . . . .	6,840	3,843	5,805	8,744	7,664	7,675	2,924
Spain . . . . .	—	—	—	—	—	453	1,751
United States . . . . .	210,241	219,318	297,041	425,100	568,690	605,721	376,566

TABLE II.  
Estimated World's Production of Aluminium.  
(Long tons)

	1913	1914	1915	1916	1917	1918	1919
United Kingdom . . . . .	7,500	7,400	7,000	7,600	7,000	8,200	8,000
Canada . . . . .	6,000	6,300	6,000	7,500	8,000	8,000	8,000
Austria . . . . .	2,900	2,900	—	—	—	—	—
France* . . . . .	13,283	9,803	5,920	9,447	10,886	11,826	12,000
Germany . . . . .	1,000	1,000	1,000	8,000	20,000	25,000	12,000
Italy* . . . . .	860	922	889	1,108	1,712	1,687	2,000
Norway . . . . .	2,000	4,000	8,000	12,000	15,000	15,000	10,000
Switzerland . . . . .	10,000	15,000	10,000	12,500	15,000	15,000	15,000
United States . . . . .	29,000	41,500	44,500	62,500	80,000	85,000	80,000
Totals . . . . .	71,643	88,125	83,309	120,655	157,598	169,713	147,000

\*Official figures. 1919 figures estimated.

**Artificial Abrasives—Carborundum and Corundum.**—The manufacture of carborundum or silicon carbide (SiC) in the electric furnace did not undergo any particular change during the period 1910-20, although the industry had developed considerably.

The electrometallurgical manufacture of artificial corundum, i.e. impure fused alumina, is new, however, and has become one of great importance in Canada.

Bauxite and coke are smelted in an arc furnace, the proportions used being as follows:—Calcined bauxite 1,750 parts; coke 100 parts; iron borings 350 parts. The furnaces used for the manufacture are mounted on water-cooled tracks, and when one is full it is removed on the rails, and another is inserted in its place under the electrodes. The furnace body is merely a rectangular iron frame lined with fire-brick, with a hearth made from pitch and carbon. The furnaces operate at 100 volts and 5,900 amperes; about 18,000 K.W.-hrs. being required to produce an ingot of 4 to 5 tons in weight. The reduction must not be carried too far, otherwise the product will be too brittle; the presence of 1 to 2% of iron, silicon, and titanium oxides, as impurities, improves the toughness of the abrasive. Brockbank gives this typical analysis of a high-grade artificial corundum:—Al<sub>2</sub>O<sub>3</sub> 97.40%, SiO<sub>2</sub> .90%, Fe<sub>2</sub>O<sub>3</sub> .32%, TiO<sub>2</sub> 1.38%.

The manufacture of artificial abrasives is confined chiefly to North America. In the year 1918, Canada alone produced 70,000 tons of these materials; while the value of the total exports of the United States was £1,000,000. Now that the limitations of silicon

and refining company was employing four 1-ton and four ½-ton furnaces, while another firm had four 1-ton furnaces, and batteries of two or three furnaces were quite common.

The following types of furnace were stated to be in successful use:—

1. The direct arc furnace, of which the Snyder is the only representative.
2. The indirect arc furnace, of which the Rennerfelt and the Detroit are the most successful examples.
3. The vertical ring induction furnace, of which the Ajax-Wyatt is the best known and most successful.
4. The granular resistance furnace, of which the Bailly is the only example.

For rolling-mills using yellow brass, the direct and indirect arc furnaces are quite unsuitable, since they would lead to high zinc losses. Likewise the induction type of furnace is unsuited for foundries where alloys high in lead are made, or where frequent changes in composition are necessary. The type of furnace to be installed, therefore, is determined largely by the alloy or metal which is to be produced, and each works will have to be guided by expert and skilled advice in the selection of the type of furnace best suited to its needs and requirements. The question of power-cost also enters into the matter, and where cheap power is available the granular resistance type may be chosen in preference to the more efficient arc type of furnace, because of the savings which follow from the absence of electrodes. Bronze manufacturers who take

power from some small central station plant may be compelled to select the two-phase Rennerfelt arc furnace instead of the single-phase Rocking Detroit furnace, because the latter type of circuit cannot be economically provided for one power user alone.

The figures in the accompanying table are given by Gillett for the output and power consumption of the various furnaces named above, when melting brass and bronze.

The electrolyte contains 30% free HCl and 80 to 85 grammes of cad per litre, with varying amounts of platinum and palladium. When the amount of these latter two metals in solution is sufficient to render it worth the expenditure of time and chemicals, a portion is withdrawn, and the platinum and palladium are then separated and can be refined by the appropriate chemical and metallurgical methods of treatment.

Type of Furnace	Power required K.W.	Charge of metal in lb.	Output per day in tons		Power consumption in K.W.-hrs. per ton	
			10 hrs.	24 hrs.		
1. Ajax-Wyatt (Yellow brass)	30 60	300 600	1-1½ 2½-3	3-3½ 6-7	325 275	267 318
2. Bailly (Yellow and red brass)	105	800 to 1500	2½-3½	6-10	475	238
3. Snyder (Leaded bearing bronze)	100 300	600 2000	1½	—	380	—
4. Rennerfelt (Red brass and bronze and bearing metal)	100 125 300	500 1000 2000	1½ 2-2½	— 7-10 10-16	475 400	290 350
5. Detroit rocking (Yellow and red brass)	40 225 300	125 1300 2000	— 3½ 6-7	— 8½ 16-20	400 332 287	325 262 237

Nos. 3, 4 and 5 use from 2½ lb. to 6 lb. of graphite electrodes per ton of metal charged.

**Bullion.**—"Bullion" is the technical term for the alloys of the precious metals silver and gold; the name is also applied to the bars or ingots in which these metals are sold (for coinage purposes) to the mint authorities of the various countries of the world. Although chemical and metallurgical methods are still employed for separating or "parting" the silver and gold in bullion from one another, and from the baser metals with which they are often associated, since the year 1855 electrolytic methods have been making steady progress, and at the present time a very large proportion of the silver output of the world is electrolytically refined by aid of the Moebius process. As regards gold, the electrolytic method is also making progress; and electrolytic refineries for treatment of gold bullion by the Wohlwill process have been operated at Frankfort, Hamburg, Paris, New York, Philadelphia and San Francisco.

The chief disadvantages of the electrolytic methods of bullion-refining are those resulting from the value of the gold and silver locked up by the processes; and the latest improvements, therefore, are directed chiefly towards reducing the volume of the solutions in the tanks, and also the time required for the refining.

The Moebius process of silver-refining has already been fully described (see 25,115). The following description of one of the latest plants erected is of interest, since it shows that the horizontal system of travelling belts which act as cathodes has been dropped, and that the vertical type of anode, enclosed in bags, has been reintroduced. The plant is attached to the Amboy Refinery of the American Smelting & Refining Co., and consists of 144 stoneware tanks, grouped in 24 sections of 6 tanks each. The anodes weigh 100 oz. and are cast by hand in the lead refinery. The cathodes are made from cold-rolled silver sheets ½ in. thick. Each tank contains 4 anode bags and 5 cathodes, the bags each holding 4 anode bars. The electrolyte is a neutral nitrate solution, containing, per litre, 15 to 20 grammes silver and 30 to 40 grammes copper; 75% of the silver in the anode can be deposited in 24 hours. The deposit upon the cathodes is continuously removed by means of wooden sticks attached to a frame which has a reciprocating motion. A current density of 40 amperes per sq. ft. can be maintained under these conditions since no treening of the silver can occur, owing to the continuous removal of the crystalline deposit.

The bags which surround the anodes receive all the slime, and are removed at regular intervals for recovery of the gold and other precious metals. The slimes are first boiled with sulphuric acid of 1.842 Sp. Gr. in order to remove copper and silver, the residue is then washed, dried, and cast into anodes for treatment by the Wohlwill process.

The gold-recovery installation at Perth Amboy is equipped with 5 earthenware cells, and a current density of 150 amperes per sq. ft. is employed. This density is considerably higher than that used in the early trials of the Wohlwill process, the object of the increase being, of course, to reduce the standing charges for interest per unit of output. One special feature of this installation is the use of mercury cups on the ends of the copper bus-bars. By aid of these cups, and cross bars of copper with bent ends to fit into these cups, any unit can be quickly cut in or cut out of the circuit. The cathodes are thin sheets, rolled from electrolytic gold, and are connected to the contact bars by bending one end of the sheet round them, and by fastening this down with a clip.

**Cadmium.**—This metal was produced during the World War period in America, by the electrolysis of acid solutions of the sulphate, freed from all impurities by chemical treatment.

The electrolysis was carried out in semi-circular lead-lined tanks provided with rotating disc-shaped cathodes of aluminium sheet, ¼ in. in thickness. Under these conditions, smooth coherent deposits of metallic cadmium could be obtained, when using a current density of 15 amperes per sq. ft. of immersed cathode area. The average weight of cadmium deposited per 24 hours in the plant referred to above was 113 lb. per tank, and the current efficiency was 85%.

As regards output in 1914, 91,000 lb. of metallic cadmium was produced in the United States, and the total had increased to 207,000 lb. in 1917. No figures were yet available in 1921 for the German output during the war years, but it was known that they also produced large amounts of cadmium and used it as a substitute for tin in the manufacture of solders. The low melting-point of cadmium renders it useful also in the manufacture of fusible plugs in sprinkle systems of fire protection; and it has also been employed in conjunction with lead for the manufacture of bearing metals.

**Calcium.**—The method of Rathenau and Suter for production of metallic calcium upon a commercial scale, by electrolysis of the fused chloride, has already been described (see 4,971).

Up to 1921 no important uses had been found for calcium; consequently there was little demand and the price of the metal remained comparatively high. Before the war calcium was quoted in Germany at M. 5.50 per kgm., equivalent to a price of 3s. to 3s. 9d. per pound. It could still be produced at this price, if a large demand for the metal were created.

The only application so far suggested for calcium is as an absorbent for the occluded and trapped gases in molten metals; and in this direction it comes into competition with the cheaper and lighter metal aluminium. Soddy, in a Royal Society paper of 1906, referred to the use of calcium for removing the last traces of O. and N. from rarefied gases, and stated that by its use very high vacua could be obtained, but no practical industrial application of this suggestion appears to have been made.

**Calcium Carbide and Calcium Cyanamide.**—The manufacture and application of these two products of the electric furnace have been described (see 1,138). Whereas the use of calcium carbide for generating acetylene for domestic or public lighting purposes is not extending, its manufacture and use as an absorbent for nitrogen increased rapidly after 1910. The cyanamide process, in fact, when operated in favourable localities, seems likely to remain one of the chief competitors of the Haber and electric-arc processes for the fixation of atmospheric nitrogen. According to reliable authorities, the relative power consumption for the three processes is as follows:—

Haber (taken as unity)	1
Cyanamide	8 to 10
Arc processes	25 " 30

Regarding power considerations alone, therefore, and ignoring technical questions, it is clear that the Haber process is of universal application—while the cyanamide process is only

advantage over the arc processes if its greater complexity can be counterbalanced by its greater efficiency. There is good evidence, however, for the belief that cyanamide costs have been very substantially reduced recently, and whereas in 1908 about 0.75 E.H.P.-year was required to produce a ton of cyanamide, the present energy consumption at Odda is believed not to exceed 0.6 E.H.P.-year per ton.

As regards the progress of the three processes, Landis has published the following comparative figures for the years 1913 and 1916:

Installed Capacity for Nitrogen Fixation Throughout the World in Short Tons of Fixed Nitrogen			
	1913	1916	
Cyanamide Process . . . . .	65,590	209,510	
Arc Processes . . . . .	18,650	29,400	
Synthetic Ammonia Processes . . . . .	8,000	60,000	
	92,240	298,910	

Most of this increase was made in 1915, and 1,000,000 H.P. is now consumed in the three groups of processes.

Before the war, there were 16 calcium cyanamide factories in existence utilizing about 200,000 H.P. in the manufacture. Even at that time, however, the larger proportion of the calcium carbide manufactured was utilized in the cyanamide industry. According to official reports, Germany possessed in 1920 plant with an annual capacity of 600,000 tons of calcium cyanamide, equivalent to 120,000 tons of combined nitrogen. This plant was distributed among six firms, the largest works being that of the Mitteldeutsche Stickstoffwerke A. G. Piestertitz, with a tonnage of 175,000 per annum. Other large works for production of calcium carbide and cyanamide are located at Odda in Norway, where an annual output of 300,000 tons eventually will be realized; at Piano d'Orte in Italy, and at Niagara Falls, where the American Cyanamide Company is operating on the Canadian side of the Falls.

**Copper.**—The very remarkable growth of electrolytic methods in the copper industry is, of course, due to the presence of small amounts of silver, gold and other precious metals in the original copper ore. These "impurities" accumulate in the slime from the electrolytic vats, and in most cases the value of this mud more than covers the whole cost of the refining operations. In 1913, the last year for which reliable aggregate statistics were available in 1921, over 1,000,000 tons of copper were produced by the copper mines and smelters of the world; and of this total it is probable that from 70% to 80% had been electrolytically refined. In mere tonnage capacity and in the capital sunk in the industry, the electrolytic copper-refining industry, therefore, easily ranks first among electrometallurgical industries; for the refineries cover immense areas and many millions of pounds' worth of copper and precious metals are locked up in the vats during the refining process.

The greater number of the electrolytic refineries are located in the United States, because the States still produce between 50 and 60% of the world's output of copper. The largest refinery is that of the United Metals Selling Co. at Perth Amboy. At Port Kembla in New South Wales, a new refinery has been built to refine the metal produced by the Mt. Morgan and other copper-mining companies of the Australian continent; and a production of 44,000 tons per year had already been attained by 1921.

The improvements made in the electrolytic refining process since 1910 have been directed chiefly towards the reduction of refining costs; and the method of operation is so well established that the only improvements possible are those based upon the substitution of mechanical for hand labour. Travelling cranes, by aid of which the whole of the anodes can be charged and the cathodes removed at one operation, are now used in all up-to-date refineries; and casting machines are also employed for casting the anode plates from the blister copper which constitutes the raw material of the refining process.

Addicks, in a recently published article upon the design of copper refineries, discusses the size and capacity of the anode melting furnaces, and states that for smooth and safe operation there should be at least six furnaces (three for anodes and three for wircar units), two of each set being in service and one out for repairs. The limit of size in the past has been the ability to charge, refine and cast the charge in 24 hours. With hand-charging and lading, using the same men for both operations, 60,000 lb. is regarded as a large furnace. If a fresh set of men be used for charging, and as many ladlers employed as can be accommodated at the ladle door, 100,000 lb.

can be reached. With hand-charging but mechanical lading 300,000 lb. is possible; and with full mechanical charging and lading 500,000 lb. is easily reached. A furnace casting a charge of 300,000 lb. or more, according to Addicks, may be considered, however, a thoroughly economical unit; but he is insistent that all the impurities possible should be eliminated at this stage of the process, for it is much more costly, in practice, to throw this burden upon the tank-house and silver refinery. It is also important, he states, to do all that is possible to facilitate uniformity of operating conditions. As a general rule, anodes of constant composition, a uniform current density and a single electrolyte should be used throughout the tank-house.

**Graphite.**—The production of artificial graphite by the Acheson process has grown into one of the most flourishing of the electro-metallurgical manufactures. The original Acheson patent which protected the process was dated 1896, and as the 17-year period allowed by American patent law had elapsed, the process after 1913 could be employed in all countries without payment of patent royalties. Consequently, there was a great expansion of the industry in countries where the demand for artificial graphite existed; and the manufacture is now carried on in the United Kingdom. The method described by Acheson in his original patent has undergone little alteration or modification in its general features, since it was first worked upon an industrial scale at Niagara Falls, in the year 1897.

The growth of the industry is shown by the following comparative figures of output at Niagara, for the two periods 1898-1900, and 1915-7 respectively:—

1898 . . . . .	185,647 lb.	1915 . . . . .	5,084,000 lb.
1899 . . . . .	405,870 "	1916 . . . . .	8,397,681 "
1900 . . . . .	860,750 "	1917 . . . . .	10,474,649 "

These totals do not include graphite used for electrodes, but only the artificial graphite which comes into competition with the natural variety.

The artificial graphite can be employed for any of the purposes for which natural graphite is used, with the exception of the manufacture of crucibles, and it is of interest to note that the recent American patent covers its application to this purpose also. The chief application of artificial graphite, however, is its use for electrodes, for which its high electrical conductivity renders it specially suitable. Its further advantages are that it can be produced in large blocks which can be sawed, tapped or screwed, and turned in the lathe to any desired shape. Some of the artificial graphite electrodes manufactured for electric furnace work have been of enormous size, namely 24 in. in diameter and 72 in. in length; and these could not possibly have been produced from natural graphite.

The production of artificial graphite was greatly stimulated during the war period by the increase in the number and capacity of the electric furnaces used for steel production and in the number of new installations of electrolytic cells for decomposition of brine; and there was a notable falling-off in the demand for these two purposes after the Armistice. In other directions, however, the use of artificial graphite has been growing, and of these applications the most notable are its use for the manufacture of lubricants, paints, dry-batteries, engine-gland packings, and boiler-scale preventives.

**Electric Steel Furnaces.**—Since 1910 a very remarkable increase has been seen in the number and capacity of electric furnaces, both for the purpose of refining the higher grades of steel and for the production of ferro-alloys, in the leading industrial and manufacturing countries of the world. This increase, no doubt, has been due very largely to war conditions. Every country, engaged in the struggle, was thrown upon its own resources with regard to the production of iron and steel; and as electric heating offered the quickest and most efficient method of converting ordinary carbon steel and scrap from the shell factories into the special steels required for the manufacture of shell billets, guns, armour plates, etc., etc., as well as for various other military purposes, electric furnaces were installed in all centres of the steel industry.

Descriptions have been given (*see* 14.824) of the Heroult arc furnace, and of the Kjellin and Rochling-Rodenhauser types of induction furnace. The latter type of furnace has not survived in the iron and steel industry, for the temperature attained in it has been too low to effect any useful refining work, and as a simple melting furnace for production of special alloy steels it is handicapped by the fact that some portion of the last charge of metal must always be left in the furnace ring to maintain the current. The Kjellin type of induction furnace as modified by Hiorth, however, is now used for the production of a specially pure iron for dynamo construction, the principle being to encase the whole secondary of



the furnace in a gas-tight ring and to melt and cool the metal in vacuo. In this way all occluded gases are removed, and the magnetic permeability of the metal is greatly increased. With this exception the successful electric steel melting and refining furnaces are now all of the arc, or combined arc and resistance heating type. Detailed figures for all countries are not available, but the following comparative figures for the United Kingdom are striking. In the year 1912, only nine electric furnaces were operating, or in course of erection, in the iron and steel works or foundries of Great Britain; Messrs. Edgar Allen & Co. of the Imperial Steel Works, Sheffield, being the pioneers in the introduction of electric steel refining into Sheffield. Six years later, in October 1918, when the Armistice was declared, the number had grown to 123 (see Table III).

TABLE III.

Electric Steel Furnaces in Operation or in Course of Erection in the United Kingdom in November 1918

Type of furnace	No.	Average capacity tons	Average monthly output	Average current consumption
1. Heroult . . . . .	50	5	9595	992
2. Electrometals . . . . .	26	2½	3097	1031
3. Greaves-Etchells . . . . .	24	2	1109	1122
4. Stobie . . . . .	8	10	1010	880
5. Snyder . . . . .	6	1	918	787
6. Rennerfelt . . . . .	5	1½	419	1495
7. Stassano . . . . .	2	2	136	1770
8. "Special" . . . . .	2	1	204	769
	123	4	16,488	1105

The average monthly output of these 123 furnaces was 16,500 tons of steel, in the form of ingot-metal, special alloys and castings. Further particulars of the types of furnaces installed, with figures for the average monthly output and current consumption, are given in the table. It must be pointed out here, however, that the figures for the average current consumption of each type of furnace cannot be used as the index of their respective thermal or electrical efficiencies, since, in the absence of information concerning the physical state and the chemical composition of the charge, and the amount of refining work carried out in the furnace, average figures of current consumption cannot be considered a safe guide to relative furnace efficiencies.

The largest number of furnaces at the end of 1918 were installed at the East Hecla Works, Sheffield, of Messrs. Hadfields, Ltd. These works were equipped with 11 Heroult arc-furnaces chiefly of 6 to 7 tons, capacity. The largest furnaces erected in England were the 12- and 15-ton furnaces of the Stobie type at Dunston-on-Tyne, and at the Openshaw works of Armstrong Whitworth & Co.

As regards the lines along which progress occurred during 1911-20, the tendency in the United Kingdom was to increase the power of the transformers, rather than to follow the American plan of reducing costs by the erection of larger furnaces. When large tonnages of electrically refined steel have been required, it has been the custom to employ open-hearth steel, which has been previously treated by the Bessemer or open-hearth process. This method of working is known technically as the "duplex" or "triple" system, and it leads to a great reduction in the consumption of electric current per ton of metal refined. Three-phase current is also now generally employed for electric steel refining in place of single-phase current, since the use of three electrodes with the molten steel as the common neutral point of the system leads to much more uniform heating of the bath. As regards regulation of the load on the generators and transformers, the Thury system of automatic regulation of the arc gap is generally employed in the United Kingdom, and by an electrically operated device the total load of a battery of furnaces can be kept within any desired limits.

In the United States, for electric steel melting and refining, the tendency is to employ larger furnaces than in Great Britain, with improved mechanical equipment for charging and discharging the furnaces. Automatic apparatus for regulating the arc gap and power factor has also been coming into general use, the Thury system of current regulation being widely adopted. As regards electrode-holders and cooling-boxes, the tendency in American practice has been to substitute cast-steel holders and boxes for the bronze ones which have been hitherto used, since there is less risk of contamination of the charge with impurities, should there be a stoppage of the flow of cooling water and fusion of the metal. The mechanism for tilting the furnaces is also receiving attention: controllers of the reversing type now being employed with a motor brake to prevent "overtravel" of the furnace, and to hold it stationary in any position. The largest electric furnaces erected up to 1921 in America for steel melting and refining are the 25-ton Heroult three-phase arc-type furnaces at the South Chicago works of the Illinois Steel Company. In 1918 this company was stated to be producing electric steel at the rate of 16,500 tons per month, using the "triple" system referred to above. The other types of electric furnace used in the American steel industry are—Booth-Hall, Girod, Greaves-Etchells, Gronwall-Dixon, Ludlum, Snyder and Von Baus.

**Ferro-Alloys.**—Applications of ferro-alloys in the iron and steel industry have increased enormously since 1911, and in 1921 the Sheffield tool-steel trade was dependent for some of its most valuable products upon the ferro-alloys obtained by aid of electric heat. The discovery made many years earlier, that small percentages of chromium, nickel, manganese, vanadium and other rare metals, either separately or in combination, caused profound changes in the physical properties of steel, has in fact revolutionized modern steel manufacture, and the production of a rustless or "stainless" steel was one of the most notable advances of the war period. Molybdenum is the latest rare metal to be added to the list of those employed now in steel manufacture; and Prof. Arnold's molybdenum-vanadium steel was expected by some authorities in 1921 to have a great future.

The special steels are called binary, ternary or quaternary, according to the number of elements (other than impurities) which are present, and it is the quaternary steels, which contain carbon and two other elements, that are now finding the widest applications in the arts and industries. The ferro-alloys used in their manufacture have in the past been supplied chiefly from the large electro-metallurgical works located in the French and Swiss Alps. The war showed, however, that dependence upon an overseas power for supplies of these essential raw materials for the steel industry was not a wise or safe arrangement. The production of ferro-alloys, therefore, was commenced in England at Widnes, Newcastle and other places, and has come to be regarded as a "key industry."

The furnaces used for the production of ferro-alloys are of the resistance type, and their design is based on that employed for the furnaces used in the manufacture of calcium carbide, but they have been modified considerably both in form and in other details of construction. The use of the electric arc for heating is not conducive to efficient working except in the steel and alloy refining processes, since the temperature required for reducing the ores lies between that of the ordinary metallurgical furnace and that produced by the electric arc. Furnaces working on the resistance principle have, therefore, been most successful in the manufacture of ferro-alloys; and arc furnaces are used only for refining. The ferro-alloys made in these furnaces in the early days of the manufacture were very impure, and the first ferro-chrome placed upon the market by a French firm contained from 7 to 9% carbon. Improvements in the design and method of working the furnaces, however, have led to the production of alloys containing a much lower percentage of this element; the percentage of carbon in some of the ferro-chrome now produced having been reduced to under two per cent. By treatment in a refining furnace this percentage can be still further reduced to under .50%, or to any lower limit demanded by the steel-maker, but this of course adds considerably to the cost of the ferro-alloy. The use of pure raw materials, the avoidance of excessive heating of the charge, and the prevention of contact between the molten ferro-alloys and the electrodes or the walls of the containing vessel are the means by which this improvement in the purity of the product has been attained.

**Electric Iron Smelting.**—Electric heat for smelting iron ore is now employed at various centres in Sweden, Norway, Italy, Japan and Brazil, where the local conditions favour the use of electrically generated heat for this purpose. The furnace employed is an improved type of the shaft-furnace originally tried in the year 1911 at Domnarvret and Trollhättan in Sweden, by the Swedish Iron and Steel Makers' Institute.

**Magnesium and Magnesium Alloys.**—Magnesium and its alloys have come to the front as metals of considerable industrial value and importance in recent years, owing to the demands of the aeroplane and motor industries for a light metal which will combine with this quality strength, toughness and ability to resist the effects of vibration and shock. The alloys of magnesium and aluminium which contain from 5 to 30% of Al have approximately the same mechanical properties as brass, and can be employed for the manufacture of screws, nuts, wire, tubes and sheets. The hardness of these Al Mg alloys increases with the proportion of the latter metal present in the alloy, and with 70% Mg the hardness is equal to that of mild steel. An alloy containing 92% Mg and 8% Al has been patented by a German firm, and is stated to have a strength equal to that of gun metal, with a specific gravity of only 1.75. If its claims are substantiated, the demand from aeroplane and motor-car manufacturers ought to result in manufacture on a large scale.

In the manufacture of the Mg Al alloys it is of great importance that the metals should be pure. The aluminium is first melted in a graphite crucible, and a small amount of cryolite is added as a flux. The magnesium in the required amount is then introduced and is

order to prevent loss by oxidation is held beneath the surface of the molten aluminium by tongs until it is melted. As regards the best contents of Mg for alloys designed for various uses, Klaudy states that a 2 to 5% Mg alloy is best for wire-drawing; 5 to 8% for rolling; 12 to 15% for casting; and that the average strength of a cast 10% Mg alloy is 20,000 lb. per sq. inch. An alloy he recommends for aeroplane construction work has the following composition:—Al 80 parts; Mg 12 parts; Cd 8 parts.

The Al-Mg-Cu alloys are stated to be useful for chemical work, as for example the alloy containing 96% Al, 2% Cu and 2% Mg. This alloy is very dense, machines well, and has been used with success for the construction of a 3-in. flanged valve, designed for work with acetic acid.

As regards the methods of manufacture adopted for producing pure magnesium, it is known that before the war the Germans were manufacturing the metal by the electrolysis of fused "carrollite," a naturally occurring salt containing potassium and magnesium chlorides. The position at the commencement of the war was, therefore, that Germany had practically a monopoly of the manufacture of magnesium, and supplied the whole world with its requirements of the metal. It was only under the stress of war conditions that English and American manufacturers commenced to take an interest in this very interesting metal.

As regards America there were, in 1921, two plants at Niagara Falls producing magnesium, under the control of the American Magnesium Corporation, and there was also one at Rumford Falls, controlled by the Rumford Metal Co. The latter plant employed as raw material a pure magnesia obtained as by-product from some other process. The Dow Chemical Co. of Midland and the General Electric Co. of Schenectady are two other firms which produced magnesium in America during the war. Concerning the process of reduction or extraction used by the plants at Niagara Falls, very little information is available. There is no doubt, however, that the process used is an electrolytic one, and that the electrolysis takes place in a bath of fused chlorides with aluminium present when an alloy is desired. At Rumford Falls, where MgO is used as raw material, the method in fact is exactly similar to that used for the manufacture of aluminium.

**Quartz-Glass and Fused Silica Ware.**—This electric-furnace product has been manufactured since 1904 at Walsley-on-Tyne by the Thermal Syndicate, and at Hanau in Germany by Heussens. Quartz is an impure form of silicic acid (SiO<sub>2</sub>); and quartz-glass is, therefore, a glass consisting chiefly of silicic acid, whereas ordinary glass contains silicic acid in combination with lime, soda, potash or lead. The great advantages of quartz-glass as compared with ordinary glass are that it has a much higher melting point and that it is not fractured by sudden changes of temperature. Other important properties are that it is neither hygroscopic nor soluble in acids, and that alkalis affect it less than ordinary glass except at the higher temperatures. It is, therefore, of great value for chemical and research work.

In the early days of the manufacture only tubes were made. The method of production was to embed a graphite rod in sand, and to heat this with a current of high amperage. A white opaque tube of quartz was obtained in this way, of much greater diameter than the graphite core. The opacity was due to the air entangled in the raw material, this air being imprisoned as minute air bubbles in the pasty mass when it softened under the application of heat. The latest method of overcoming this defect is to heat the fused tube a second time quickly up to 1800° C. by aid either of an oxyhydrogen flame or of the electric arc. The cellular structure then collapses, and a semi-transparent tube is obtained which is not only stronger but is a better conductor of heat than the original opaque tube. The highest grade of glass-sand and modern methods of blown-glass manufacture are now employed, with the aid of iron moulds similar in construction to those used for glass bottles, to produce any hollow kind of fused silica ware.

**Sodium.**—The Castner cell and process for the production of metallic sodium by the electrolysis of fused sodium hydrate has been generally adopted.

In a recent American patent, No. 1,324,179 of March 1920, and assigned to the Dow Chemical Co., A. W. Smith and W. R. Veazey, of Cleveland, proposed to substitute a mixture of 35.6 parts of sodium chloride and 64.4 parts of sodium carbonate for the more expensive sodium hydrate. This mixture melts at 600° C. and yields a product equal in quality and purity to the present commercial sodium.

**Tin.**—The application of electrolytic or electrothermal methods in connexion with the tin industry has been confined to the recovery of the metal from tin scrap and from the old tin cans found in the refuse of all large towns. At one time the electrolytic recovery of tin from these two sources became a branch industry of some importance; but these electrolytic methods of treating tin-scrap metal and refuse had in many places

been displaced by 1921 by newer methods, depending upon the use of liquid or gaseous chlorine. The electrolytic methods, however, continued to be carried on by some municipalities.

The alkaline process of electrolytic tin-stripping was patented first in the United Kingdom, by an Englishman named Beaton; but the German firm, Th. Goldschmidt & Cie., of Essen, Germany, was the first to see and to turn to good account the possibilities of the process. This firm, by organizing the collection of the waste scrap in all countries and its transport on a large scale to their works at Essen, obtained at one time almost a monopoly of the raw material of the industry. The scrap, after cleaning and freeing from grease and fat, was employed as anode material in baths which contained a 10% sodium-hydrate solution as electrolyte. Under the influence of the current the tin was dissolved as sodium stannate, and was deposited at the cathode as metallic tin, with reformation of the sodium hydrate. The chief chemical, therefore, was continuously regenerated, and the only drawback of the process was that the solution of the tin was not quite complete, and the iron-tin alloy, which existed on the plate under the coating of tin, was not dissolved by the sodium salt. The residual iron left in the vats still carried, therefore, measurable and variable amounts of tin, which diminished its value from the steel-melters' point of view.

At one time before the war, the alkali process of tin-stripping was being worked at seven different centres in Europe and at one or two in America, and over 40,000 tons of tin scrap was treated annually by the process. A plant which operated in Limehouse, London, was reported to be using the same process.

Electrolytic tin-stripping methods, which are based upon the use of ferric and stannic chlorides as solvent for the tin, have been patented and tried also upon a commercial scale. Their great advantage is that the solder and hard alloy of iron and tin, under the tin coating is removed by the chloride treatment; and that only one-half the electric current required by the alkali process suffices to deposit the tin from the chloride electrolyte. The Bergue and Browne & Neil processes of tin-for-lead treatment were the most notable examples of this method in the past. More recently, Walter and Lodge have patented the use of a stripping solution consisting of a 7% solution of caustic soda or potash, with 1% of stannous chloride, heated to 180° F. The scrap is placed in bags in a perforated revolving drum, which is rotated or oscillated within the vat, and is divided into longitudinal compartments by the cathode plates which project into it internally. The method is protected by British patents Nos. 122,025 and 122,618 of 1918, and is reported to have been operated in Birmingham.

**Zinc.**—The many different processes which had been patented or experimented with, up to the year 1910, for the electric deposition of zinc from sulphate or chloride solutions of the metal paved the way for the improved methods and processes of the later period, and there were in 1921 many large plants in operation in America and Australia, producing electrolytic zinc upon an industrial scale. Success depends upon freeing the electrolyte supplied to the depositing vats from all impurities more electro-negative than zinc—copper, cadmium, lead, antimony and arsenic. The presence of even very minute amounts of the two last-named impurities (arsenic and antimony) is found, in fact, to lead to low-current efficiencies. The non-recognition of this fact led to the failure of many of the electrolytic processes that were tried upon an industrial scale in the past. The other essential of success is to prevent "treering" of the deposited zinc, since this leads to short-circuiting in the vats; and "treering" has been overcome by stripping the cathodes every 48 hours, and by not attempting to form thick sheets of zinc.

The most modern and largest plant in which electrolytic zinc was being produced in 1921 was that erected in 1918 by the Anaconda Copper Co. at Great Falls, Mont., for recovery of the zinc from the complex zinc-lead ores of the Butte district, by a sulphate leaching process. The tank-house of this plant contains 864 vats, each 10 ft. long by 3 ft. wide by 5 ft. deep; and each vat will hold 28 anodes and 27 cathodes. The latter are of rolled sheet aluminium from which the deposited zinc can be stripped easily. The anodes are of chemical lead. The current for each unit of 144 cells is supplied by a rotary converter of 5,800 K.W. output, 10,000 amperes at 580 volts being required to run this number of cells. At full load the current density employed is 30 amp. per sq. ft. of cathode area, but 22 to 25 amp. yields the most satisfactory deposit.

Similar plants have been erected and operated at Park City, Utah, by the Judge Mining and Smelting Co. for treatment of the concentrates from a sulphide ore containing zinc, lead and silver; and at Trail, B.C., by the Consolidated Mining & Smelting Co. of Canada. This latter company claims to have been the first to put electrolytic slab zinc on the market at a cost which left a profit to the producer. The average composition produced at Trail, B.C., is Zn, 99.93%; FeO, .005%; Pb, .038%; Cd, .027%.

*Electroplating*.—The electrolytic deposition of a coating of zinc, from sulphate solutions, upon iron articles is now a well-established industry in all the leading manufacturing countries.

**AUTHORITIES**.—Apart from articles in technical journals reference may be made to the following books:—A. J. Allmand, *Principles of Applied Electrochemistry*; B. Blount, *Practical Electrochemistry*; A. J. Hale, *The Applications of Electrolysis in Chemical Industry*; J. B. C. Kershaw, *Electrometallurgy*; idem, *Electrothermal Methods of Iron and Steel Production*; Jean Escard, *Les Fourneaux Electriques industrielles*; idem, *L'Electrometallurgie du Fer et ses Alliages*; W. Rodenhauser and I. Schwonawa, *Electric Furnaces in the Iron and Steel Industry*. (J. B. C. K.)

**ELGAR, SIR EDWARD** (1857— ), English composer (see 9.266), received the O.M. in 1911. His first symphony, produced at Manchester 1908, created a furore and was played upwards of 100 times in a twelvemonth. It was followed by the violin concerto; *Falstaff* (Leeds); the 2nd symphony in E flat; and all these by a wonderful series of compositions written during the World War. *The Spirit of England* (poems by Lawrence Binyon), *Coriambus*, a pianoforte quintet, a string quartet in A minor and a 'cello concerto were produced between 1914 and 1920.

His wife, Caroline Alice Roberts, the daughter of Maj.-Gen. Sir Henry Roberts, whom he married in 1889, was herself an accomplished musician and linguist. She was the author of various poems, including *In Hæsen*, set to music by her husband in *Sea Pictures*. She died at Hampstead April 7 1920.

**ELGIN, VICTOR ALEXANDER BRUCE, 9TH EARL OF** (1849-1917), British statesman (see 9.268), died at Broomhall, Fife, Jan. 18 1917.

**ELIOT, CHARLES WILLIAM** (1834— ), American educationist (see 9.274), was offered the post of ambassador to England by President Taft in 1909, but preferred to serve his country in a private capacity at home. The same position was tendered him in 1913 by President Wilson and again declined. He continued to take an active part, by writing and speaking, on all the important public questions of the day. His theories as to needed changes in education toward the concrete and practical had great influence upon American schools. The vocational movement, so marked after 1910, was without doubt accelerated by his continued insistence upon the training of the senses of sight, hearing and touch, as being the sources of the best part of knowledge. In 1914 he was elected president of the American Association for the Advancement of Science. In his educational writings he maintained that the traditional systems had dealt too exclusively with language and literature. In 1916, however, he was awarded a gold medal by the American Academy of Arts and Letters for his literary influence in his educational work. In the field of religion he was an authoritative spokesman on the Unitarian faith. In his later books, *The Religion of the Future* and *Twentieth Century Christianity*, he rejected obscure dogma, emphasized freedom in place of authority, and held that the teaching of Jesus had been "the undying root of all the best in human history since He lived," and that He would be the supreme teacher in the new religion, the outcome of which would be the brotherhood of man. Dr. Eliot gave much attention to labour problems and declared that "profit-sharing, combined with cooperative management, in which the employees take active and reasonable part, with cooperative care of health, education and happiness of employees, and with full knowledge by employees of the employers' account, is the only road to industrial peace." He condemned limited output by labour as well as uniform hours and wages. The settling of industrial strife he considered the next important thing after the establishment of a league of nations. He was a strong supporter of President Wilson's administration, and approved his personal appeal to the country in 1918 to return a Democratic Congress. He favoured prohibition as a war measure, and later as an amendment to the Constitution. He wrote in favour of military training after the Swiss method, but maintained that, after a league of nations was formed, no country should be allowed to have an army "whose officers have entered for life the profession of soldier." In 1920 he was an active worker for the Democratic party because he regarded

the immediate adoption of the Covenant of the League of Nations as a moral obligation. He was the author of *The Conflict Between Individualism and Collectivism in a Democracy* (1910), lectures delivered at the university of Virginia; *Some Roads Towards Peace* (1914) and numerous articles on educational, religious, political and social questions.

**ELLIOTT, HOWARD** (1860— ), American railway manager, was born in New York Dec. 6 1860. After graduating from the Lawrence Scientific School, Harvard (C.E. 1881), he was for several years a clerk in various offices of the Chicago, Burlington & Quincy railway. Later he was appointed general freight agent and then general manager of several lines belonging to the Burlington system. In 1902 he became second vice-president of the company and the following year president of the Northern Pacific. In 1913 he was made president of the New York, New Haven & Hartford railway and at the same time chairman of its board of directors. In 1917 he resigned and was made chairman of the committee on intercorporate relations of the New Haven system. The same year he was named by the American Railway Association as one of the six members of the Railroads War Board. He was again president of the Northern Pacific 1919-20, and then became chairman of its board of directors. He opposed the eight-hour law, urged higher freight rates, and suggested the creation of a department of transportation, with a secretary in the Cabinet.

**ELLIS, ROBINSON** (1834-1913), English scholar (see 9.294), died at Oxford Oct. 9 1913. Among his later publications were editions of the *Amores* of Ovid (1912) and the second book of Ovid's *Tristia* (1913).

**ELWES, GERVAASE GARY** (1866-1921), English vocalist, son of Valentine Cary Elwes, of Billing Hall, Northants, and Brigg, Lincs., was born at Billing Nov. 15 1866. Educated at the Oratory school, Edgbaston, and at Christ Church, Oxford, Gervase Elwes married Lady Winifride Feilding, daughter of the 8th Earl of Denbigh, in 1889, and two years later, on appointment to the diplomatic service, he became honorary attaché at Munich, then at Vienna and finally at Brussels. Possessed of a charming tenor voice, he became known as an amateur singer of exceptional ability, and in the three cities named he studied music assiduously, in Vienna under Mandyczewski and in Brussels under Demest, while he also paid frequent visits to Paris from Brussels in order further to study under Bouhy. He entered the musical profession while still in the diplomatic service, which he finally abandoned in 1895. As a professional singer he made his first public appearance at the Westmorland Festival in 1903, and in London at a concert of the Handel Society. In London he continued his studies under Victor Beigel, sang with conspicuous success at the Monday "Pops," at the Kruse festival and at provincial festivals. His first representative festival engagement was at Leeds in 1904. In 1907 he toured Germany with Fanny Davies; two years later he sang with the Oratorio Society of New York in Bach's *St. Matthew Passion* and *The Dream of Gerontius*, the latter a work with which his name became indissolubly associated. He took part in upwards of 150 performances of it. His intensely deep religious convictions undoubtedly aided him in this work, for he was a very devout Catholic, and in Bach's *Passion* his performance was exalted. As a singer of songs Elwes held a unique position. He excelled in the *lieder* of Brahms; and to him such English composers as Roger Quilter and Vaughan Williams owed a fair proportion of their success, at least in the beginning. Elwes left England late in 1920 for a long-promised tour of the United States, and he was accidentally killed at the railway station at Boston on Jan. 13 1921.

**EMBRYOLOGY**.—In the earlier article (see 9.314) the growth of the science of embryology was traced from the period of the Renaissance until the beginning of the 20th century. It remains here to deal with the more recent discoveries as to the nature and meaning of the developmental process.

*The Cell*.—We take for granted (see CYTOLOGY) a general acquaintance with the structure of the bodies of adult animals. It is now a matter of universal agreement to conceive the active

living parts of these bodies, which are included under the general name protoplasm, as built up of a series of units termed cells, each normally containing a single nucleus and separated from one another by quasi-solid membranes termed cell-walls.

The doubts as to the validity of the concept of the cell, which were raised in the later years of the 19th century, have not been sustained by later discoveries. A more refined technique has enabled us to demonstrate a cell-wall in cases where it was supposed to be absent; and where it really is absent, as for instance in the ectoderm of the Nematode worms, it has been proved that this is a secondary state of affairs, due to the degeneration of a well-developed layer of cells, which in younger stages of the life-history are clearly and sharply delimited from each other. It is true that in many, perhaps in most, cases the cell-walls are perforated so that adjacent cells are connected by bars of protoplasm, but this circumstance in no way invalidates the idea of the cell as the unit of structure.

*Scope of Embryology.*—The lowest grade of animals, termed the Protozoa, do not exhibit cellular structure. Either their bodies are so small that they possess only one nucleus, and in this case they may be regarded as free-living cells; or they contain more than one nucleus and attain a greater size, and then their protoplasm is not divided into compartments in accordance with the distribution of these nuclei.

Some of the largest of the Protozoa such as the extinct genus *Nannosulites* were disc-like in form and attained a size of an inch in diameter; the bodies of these animals were divided into thousands of compartments by calcareous septa. To judge from what we know of the structure of their nearest living representatives they must have possessed numerous nuclei; but these nuclei were not distributed in accordance with the divisions of the protoplasm. Some compartments contained several nuclei, some one nucleus only and many none; so that true all-structure was absent.

In other cases the protozoön may be described as a colony of small uninucleate forma, connected together either by strings of protoplasm or by stalks springing from a common base. But all these more complex Protozoa are distinguished from the true higher animals or Metazoa by the fact that when reproduction takes place the whole body of the parent breaks up into germs, each containing a single nucleus, whereas in true Metazoa small portions only of the parent's body are set aside for reproductive purposes; in other words, in the Metazoa there is a persistent "soma" or body distinct from the germ-cells. Now of course the development of the Protozoa ought to form part of the subject matter of embryology, but in the case of the smaller species it is exceedingly difficult to say which stage corresponds to the adult condition of Metazoa, since reproduction by the division of the mother's body into two, can take place at various periods in the life-cycle, and therefore purely as a matter of convenience it is customary to confine the subject matter of embryology to the study of the life histories of the higher animals which exhibit definite cellular structure, in a word to the Metazoa.

*Metazoa.*—If we now examine the development of the Metazoa we find a few cases where, side by side with other methods, reproduction by fission, that is by the division of the mother's body, does actually take place.

Thus in the marine annelid *Procerastes* described by Allen<sup>1</sup> the mother worm breaks up into groups of one, two or three segments and each of these groups regenerates the missing parts and thus constitutes a new worm. In much more numerous cases an outgrowth of the mother's body, termed a "bud," is produced. The bud consists from the beginning of several tissues, and is slowly moulded into the likeness of the parent and when fully grown separates from it, or in the case of a colonial animal remains connected with it and helps to build up a compound organism. Such compound creatures are found amongst the sponges, the Coelenterata, the Polyzoa, and the Ascidians, the last-named group being degenerate allies of the Vertebrata.

The laws of bud-development have not been as clearly elucidated as those of the germ-cells. Development by germ-cells is universal amongst the Metazoa; and in all but two phyla the form in which they appear is remarkably constant. They are of two kinds, viz. male and female, and are normally incapable of development unless they have previously united in pairs to form what are called "zygotes" (Gr. ζῦγος, a yoke).

The male cell or spermatozoon consists of a head which is a condensed nucleus made up of a compact mass of chromatin, and a tail

which is a vibratile filament. Amongst the nematode worms, however, the male cells are devoid of filaments and appear under the form of small amoeboid cells, whilst amongst the higher Crustaceans (i.e. the shrimps, lobsters and crabs) the tail is replaced by a peculiar vesicle, which under certain circumstances absorbs water and explodes, thus propelling the head forwards and in this way bringing about the union of the two germ-cells.

*The Germ-cells.*—The female cell or ovum (egg) is typically rounded and motionless but it is of very different sizes in different species of animals. These differences in size depend entirely on the varying amounts of food-yolk—i.e. reserve material—deposited in the cytoplasm; that is to say, in the extra-nuclear protoplasm. The food-yolk in turn differs in amount according to the extent to which the young organism must grow before it can obtain nourishment for itself. Thus the human egg is only about .1 mm. in diameter since at a very early period of its development it becomes attached to the wall of the womb and subsequently draws all its nourishment from that source. The egg of the ostrich on the contrary is one of the largest known, being about 15 cm. in diameter, since it has to provide all the food necessary to build up a good-sized chick.

Eggs which contain a very small amount of yolk and in which this is evenly distributed throughout the cytoplasm are termed "alecithal"; such are the eggs of Hydrozoa, Echinodermata, Brachiopoda and of Amphioxus and Mammalia amongst Vertebrata. Eggs in which the yolk is concentrated at one pole of the egg are termed "telolecithal"; this pole is termed the "vegetative pole," whilst the opposite pole where the bulk of the cytoplasm is concentrated and where the polar bodies (see below) are given off is termed the "animal pole." The eggs of most Annelida and Mollusca and of Pisces, Amphibia, Reptilia and Aves amongst Vertebrata are telolecithal. Eggs in which the yolk is massed in the central part of the egg and is surrounded by a layer of cytoplasm almost free from yolk are termed "centrolecithal." To this class belong the eggs of nearly all Arthropoda.

Both types of germ-cell before attaining maturity undergo two ripening (*maturation*) divisions, so that in each case four daughter cells are produced. Whereas in the case of the male germ-cell all four daughters become fully formed *spermatozoa*, in the case of the female germ-cell only one daughter is converted into the ripe egg; the remaining three are small vestigial cells destined to perish, which are termed the "polar bodies." During the maturation divisions the number of chromosomes in the nuclei of both male and female germ-cells is reduced by one-half (for details of this process see CYTOLOGY). When the spermatozoon enters the egg, the head, which is a condensed nucleus, swells up and assumes the ordinary nuclear structure and is termed the "male pronucleus"; behind it is situated a very active centrosome (see CYTOLOGY) which produces a series of radiating rays termed the "spERMMASTER." The nucleus of the ripe egg is termed the "female pronucleus." The male pronucleus approaches the female pronucleus, and the spermaster constitutes the groundwork of the first mitotic spindle by becoming divided into two asters connected with one another by longitudinal fibres; this spindle initiates the development of the egg by bringing about the first division of the combined male and female pronuclei and of the fertilized egg (zygote) itself. The tail of the spermatozoon is either left outside when the head penetrates the egg, or if it penetrates the cytoplasm it degenerates there; its remnants can sometimes be detected in one cell of the embryo, up till the stage of 32 cells has been attained, but it takes no part in cell-division and no portion of it is transmitted to any other cell, the conclusion being that it plays no part in the transmission of hereditary qualities.

The nucleus of the zygote, as we have just seen, has double the number of chromosomes which are present in the nucleus of the ripe egg but half of these are of male origin. Every nucleus of the developing embryo therefore inherits from the zygote nucleus an equal number of male and female chromosomes, so that the body of the embryo has with justice been likened to a tissue of which the warp is paternal and the woof maternal.

*Parthenogenesis.*—In the earlier article it was pointed out that the unfertilized egg could be induced to develop by a variety of agencies varying from the addition of a small quantity of butyric acid to the sea-water in which it is placed, followed by exposure to the action of hypertonic (i.e. over-salted) sea-water in the case of echinoderm eggs, to the prick of a pin in the case of the eggs of Amphibia. This is termed *artificial parthenogenesis*.

In the case of the eggs of the sea-urchin (*Echinus*) parthenogenesis has been minutely studied by Loeb<sup>2</sup> who has put forward various theories as to the action of the agents which he employed. He imagined that the action of the butyric acid was to start cytolytic, one result of which was the formation of a definite egg membrane, but which if unchecked destroyed the egg, which became resolved into a mass of globules. The exposure to hypertonic sea-water was supposed to arrest this injurious action. This explanation was obviously not applicable to the parthenogenesis of the frog's egg.

<sup>1</sup> E. J. Allen, "An Autotomy and Regeneration in the syllid worm *Procerastes*." *Proc. Roy. Soc. Lond.*, Series B, vol. xcii, 1921.

<sup>2</sup> J. Loeb. Numerous papers summarized in his book *Die chemische Entwicklung des tierischen Eies* (1909).

The whole subject has been attacked from a new point of view by Herlant<sup>1</sup> and Brachet<sup>2</sup> who have pointed out that the agent employed to provoke parthenogenesis does not exercise a specific chemical action on the egg but merely acts as a stimulus to which the egg as a living organism responds. Whether butyric acid or a needle be employed the response is the same; the egg "wakes up," so to speak, the nucleus emits something which acts as a centrosome and from this is developed a great series of radiating rays traversing the cytoplasm, a huge "monaster" in fact. The chromatin of the nucleus becomes resolved into chromosomes which are split longitudinally and which become adherent to the rays of the "monaster." In the case of the egg of the sea-urchin it is only extremely rarely that the monaster becomes changed into an ordinary mitotic spindle by the division of the centrosome. In most cases after persisting for about an hour the monaster disappears; the nucleus returns to the resting condition and then after a short interval it passes through the same phases, a monaster being again formed. After this process has been repeated about six times over a period lasting twelve hours the egg dies and cytolytic supervenes. If, however, after the egg has been exposed to the action of the butyric acid and then washed in sea-water it is placed in hypertonic sea-water, and then after a limited period of immersion in this fluid replaced in ordinary sea-water, additional asters are formed in the cytoplasm. When the egg forms a monaster this becomes connected with these other asters by longitudinal fibres so as to form a complex spindle. By properly choosing the period of immersion in hypertonic water it is possible to arrange that only one additional aster should be formed; this then joins with the monaster to form a normal mitotic spindle on to which the egg chromosomes migrate; a regular division of the nucleus follows and thereafter a division of the whole egg into two cells and so parthenogenetic development is initiated.

The course of events in the frog's egg is fundamentally similar to the process which we have just described, although there are differences in detail. A prick with a sterilized needle induces the formation of a huge monaster, which then divides into two forming a short mitotic spindle on to which the chromosomes of the egg migrate. Since, however, the length of the spindle stands in relation to the number of chromosomes in the nucleus and as these chromosomes are only present in half the number found in the nucleus of the fertilized egg, the spindle which is formed is only four-fifths of the length of the first spindle formed in the fertilized egg. The length of spindle in turn determines the length of the actual rays from its poles, and if these are too short to reach the periphery of the egg the spindle is unable to bring about the division of the egg into two cells. This is the case with the spindle formed in the parthenogenetic egg, and although abortive and transitory furrows on the egg's surface are formed no division into cells results; the nucleus, it is true, divides and a multiplication of nuclei follows in which the numerous short spindles formed interfere with one another and make orderly development impossible and so after a short time the egg dies.

If, however, the needle be "infected" by being dipped into frog's blood before being used to prick the egg, then the foreign substance thus introduced produces additional asters in the cytoplasm just as did the hypertonic water in the sea-urchin's egg. These asters have a tendency to their rays develop, one around another and they push the mitotic spindle developed around the egg nucleus over to the one side. If this side happens to be the side of the egg at which the cytoplasm is concentrated, then the spindle is able to start the formation of a furrow which cuts right through the egg and divides it into two cells, and so parthenogenetic development is begun. We see then that the difficulty of initiating parthenogenesis depends on two factors, viz. (1) the quiescent condition of the egg and (2) the small amount of chromatin present in the nucleus. If we choose the unripe eggs of the sea-urchin as the subjects of our experiment then it is sometimes possible to induce them to develop by the use of one reagent alone, such as hypertonic sea-water; since in these eggs the "reducing" division of the nucleus has not occurred (see CYTOLOGY) and the chromatin is consequently present in undiminished quantity.

Parthenogenetic development is closely related to the problem of heterogeneous fertilization. It has been shown that under certain circumstances it is possible to fertilize the eggs of the sea-urchin with the sperm of creatures so diverse in zoological affinity as the annelid worm (*Chaetopterus*) and the sea-mussel (*Mytilus*). In the first case the male and female pronuclei fuse but the male chromatin falls out of the zygote nucleus before the first division takes place. In the second case the male pronucleus refuses to enter into union with the female pronucleus at all, but the sperm-aster brings about the division of the egg. When the eggs of the sea-urchin (*Echinus*) are fertilized with the sperm of the

heart-urchin (*Echinochordium*), in the vast majority of cases cytolytic results exactly as it does after the exposure of the echinus eggs to the action of butyric acid, but in some few cases the egg develops and produces a hybrid. We conclude that in most cases the sperm of *Echinochordium* is so alien to the cytoplasm of the egg of *Echinus* that it is not even able to bring about the formation of a sperm-aster.

Under certain circumstances (slight staleness of the egg, excess of sperm, etc.) more than one spermatozoon may enter the egg. In large eggs such as those of cephalopoda, reptiles and birds this seems to be a normal occurrence; only one of these nuclei unites with the female pronucleus and forms the zygote nucleus from which begins the cell-division which initiates development; but the other spermatozoa also form centres for cell-division which gives rise to the so-called free cells which are characteristic of these eggs. These free cells are gradually crushed out and destroyed by the developing cells produced by the activity of the zygote nucleus.

Brachet, however, has shown<sup>3</sup> that when the frog's egg is entered by spermatozoa in moderate numbers, whereas only one unites with the female pronucleus, the others form centres for the formation of cells which are built up into the body of the embryo. As these sperm-heads, however, contain only half the quantity of chromatin contained in the zygote nucleus, the cells to which they give rise are markedly smaller than those which contain nuclei descended from the zygote nucleus, and so it is possible to distinguish in the growing tadpole the regions which contain cells which have nuclei derived from the zygote nucleus from those which contain cells having nuclei derived from the supernumerary spermatozoa.

Brachet's observations prove in the clearest manner that the differentiation of organs in the frog's egg is due to the differentiation of regions in the cytoplasm and not to the differentiation of the nuclei produced by the division of the zygote nucleus as Weissmann<sup>4</sup> had supposed, for some of these nuclei can be replaced by sperm-nuclei each of which carries in it the potentiality of producing the whole organism—not a mere region of it—and yet no dislocation of development results.

The entry of two or more spermatozoa into small eggs such as those of the sea-urchin usually produces abnormal development followed by early death. The reason is that the centrosomes which are carried into the egg by these spermatozoa are so near each other that instead of leading to the formation of separate spindles they give rise to three- (trister) or four-poled (tetrastr) spindles along which the chromosomes are arranged in an irregular manner. This causes the formation of abnormal nuclei incapable of properly fulfilling their functions and the embryo dies.

**Development of the Egg.**—If we now turn to consider the normal development of the egg we find that this can be divided into three stages which in primitive forms are sharply delimited, but which in more modified forms tend to overlap one another. These stages are (1) segmentation, or the division of the egg into a number of indifferent cells or blastomeres; (2) the formation of the so-called germ layers, i.e. the differentiation of the blastomeres into the primitive organs—viz: (a) the ectoderm (or epiblast) which is the primitive skin, (b) the endoderm (or hypoblast) which is the primitive lining of the gut, and (c) the mesoderm (or mesoblast) which is the primitive peritoneum or lining of the body-cavity; (3) organogeny, i.e. the formation of the separate organs of the body, such as brain, liver, kidneys, etc., from the germ-layers.

**Segmentation of the Egg.**—Considering first the process of segmentation, we find, as Ballour<sup>5</sup> pointed out long ago, that the effect of the accumulation of yolk in the egg is to impede cell-division. It acts exactly as if it were a dilutant of the cytoplasm in lowering surface tension. Cell-division is accompanied by a great increase in surface tension as is obvious from the way each daughter cell rounds itself off from its sister. This is particularly evident in the segmentation of alecithal eggs, for in them, in the early stages of segmentation, all the blastomeres divide simultaneously, and just after each period of division these take on the appearance of a pile of balls only touching each other in points; whereas during the interval between two such periods the surface tension diminishes and the blastomeres become flattened out against each other.

In all alecithal and telolecithal eggs there is a pole (see above) from which the polar bodies are given off which is termed the animal pole of the egg. This pole is the region of the egg which contains least yolk; here cell-division is most rapid and the smallest blastomeres are produced, whereas as we pass towards the vegetative pole of the egg, where the yolk is concentrated, the blastomeres become larger and larger.

<sup>1</sup> M. Herlant, "Le Mécanisme de la Parthénogénèse Expérimentale." *Bull. Scientifique de la France et de la Belgique*. 7th Section, vol. 1, 1917.

<sup>2</sup> Brachet, "Euf et les facteurs de l'Ootogénèse." *Encyclopédie Scientifique*, Paris, 1916.

<sup>3</sup> Brachet, *loc. cit.*

<sup>4</sup> A. Weissmann, *The Germ-Plasm. A Theory of Heredity* (1902).

<sup>5</sup> F. M. Ballour, *Treatise on Comparative Embryology*, vol. 1., p. 95

When the yolk is very much increased in amount, the nuclei produced by the division of the zygote nucleus are unable to bring about a surface tension sufficient to divide the cytoplasm, and so we get a multiplication of nuclei without the formation of blastomeres. When this happens segmentation is confined to the animal pole of the egg and results in the formation of a thin disc of blastomeres termed the "blastoderm," resting on an unsegmented "yolk." Such eggs (for instance the hen's egg) are termed "meroblastic" (gr. *meros*, a part) in contradistinction to eggs, like those of the frog, which are completely divided and are termed "holoblastic."

In centrolethalic eggs, like those of the crayfish, the egg appears to be completely divided into cells, but although division may at first be complete, the lowered surface tension of the inner yolky ends of the blastomeres is unable to keep them apart and they flow together so as to form a common inner yolky mass. Such eggs are said to exhibit *superficial segmentation*. Later, the outer protoplasmic ends of these incomplete blastomeres become completely cut off, so as to form a skin of cells of blastoderm surrounding a central "yolk." A still further modification of this type is found in the eggs of insects in which the yolk is so abundant as to prevent all segmentation. The zygote nucleus alone divides and gives rise to daughter nuclei each surrounded by an island of protoplasm; these are at first dispersed throughout the "yolk" but they gradually migrate to the surface and here form a blastoderm.

In primitive alicethal eggs segmentation results in the formation of a hollow ball of cells one layer thick. This ball is termed the "blastula" and its cavity the "blastocoel," "segmentation-cavity," "primary body-cavity." The formation of the blastula marks the accomplishment of an important step in development. Although typically formed only in alicethal eggs, it appears in a modified form in telolecithal eggs, even in those in which there is so much yolk that they have meroblastic segmentation. Thus in the case of the frog the blastula is a hollow ball of which the roof is two cells thick and the floor is many cells thick, whilst in the case of the pigeon the blastula is represented by a stage in which the blastoderm is one layer thick and forms the roof and is separated by a slit-like cavity from the immense mass of the unsegmented yolk forming the floor in the uppermost layer of which are a few nuclei. These nuclei are representatives of the cells which should constitute the vegetative pole of the blastula but they are utterly unable to cut the yolk up into cells.

**Formation of Germ Layers.**—As soon as the blastula stage has been attained, the "formation of layers" begins. The cells at the vegetative pole become turned inwards, forming a tube-like structure which projects into the blastocoel and partially obliterates it. This tube is the primitive gut or "archenteron" and the cells forming it are termed the "endoderm," whereas the cells forming the outer wall of the blastula give rise to the primitive skin and are termed "ectoderm." Driesch<sup>1</sup> has shown that until the archenteron begins to be formed all the cells of the blastula of *Echinus* are alike in their potencies; any sufficiently large piece of it, if cut off, will round itself off and form a blastula and ultimately a perfect larva of diminished size; after a region has been delimited as the centre of the formation of the endoderm the rest of the blastula, wall, if cut off, can no longer form an archenteron and so it follows that when the endoderm is differentiated at one place, the rest of the blastular wall becomes changed into definitive ectoderm.

When the archenteron has been formed the developing egg has assumed the shape of a double-walled cup, the opening into which is termed the "blastopore." This stage is clearly and sharply marked in the development of almost all eggs in which the yolk is small in amount, and it can be recognized in an obscured and altered form in the development of large yolky eggs. It is of equal importance to the blastula stage, and it is termed the "gastrula."

The primary body-cavity has now become reduced to the slit intervening between the wall of the archenteron and the outer wall of the gastrula, and this is largely filled up by the development of the third germ layer, the "mesoderm." We have defined this layer as the primitive peritoneum or lining of the body-cavity, but the body-cavity now indicated is termed the "coelom" or "secondary body-cavity" in order to distinguish it from the primary body-cavity. In the eggs of primitive animals, where the yolk is small in amount, the coelom is always formed as a series of pouch-like outgrowths of the archenteron which become cut off from this tube. It follows that the mesoderm is differentiated from the primary endoderm. Driesch<sup>2</sup> has shown that if the front half of the gastrula of the starfish which includes the apex of the archenteron be cut off, the hinder half will heal up and will form a perfect larva, forming, of course, the coelom in the normal way. If, however, this operation be performed after a swelling of the tip of the archenteron—the first rudiment of the coelom—has appeared, then, although the hinder half will heal up and form a larva, it never forms a coelom. Driesch concludes from this experiment that at first all parts of the archenteron wall have the power of giving rise to a coelom, that is of forming mesoderm, but that later a definite portion of this wall becomes set aside as the rudiment of the coelom and that then

the rest of it becomes the definitive endoderm devoid of this coelomy forming power. In Echinodermata the coelom arises as a single pouch from the apex of the archenteron; in primitive Vertebrata it originates as five pouches of which one is apical and four are paired and lateral; in Chaetognatha and Brachiopoda as a lateral pair of pouches. The remnant of the primary body-cavity becomes almost filled up with cells budded from the wall of the coelom which are termed "mesenchyme." These cells may become joined to one another by their processes and thus constitute a network which becomes converted into connective tissue by the secretion of fibres; or they may remain separate from one another, and then they become developed into blood and lymph cells, the remnants of the primary body-cavity constituting the blood-spaces. In the Coelenterata, in which no coelom is formed, similar cells are budded from both ectoderm and endoderm; in Annelida and Mollusca, in addition to the mesenchyme given off from the coelomic wall, some is likewise budded from the ectoderm, and to this the name "mesectoderm" has been given. In Vertebrata the most recent research indicates that no mesenchyme is given off from the ectoderm.

**Organogeny.**—Turning now to the third stage of development, viz. the formation of special organs, we find that from the ectoderm are derived the central nervous system and the sense organs, and also the lining of the mouth-cavity and of the terminal portion of the alimentary canal near the anus. The endoderm gives rise to the middle portion of the gut and to the glands which line the back-bone or "notochord." From the mesoderm arise muscles, the epidermis, the connective tissue, and, in Vertebrata and Echinodermata, the internal calcareous skeleton which is derived from the connective tissue. The mesoderm also gives rise to the genital organs and their ducts in all Metazoa above the rank of Coelenterata and in Mollusca and Vertebrata to the kidney tubules.

Now we have pointed out that, in telolecithal eggs, segmentation proceeds most rapidly at the animal pole; here the second stage of development rapidly supervenes, and the archenteron is begun before segmentation is even initiated at the vegetative pole. In meroblastic eggs the upper pole of the egg may become converted into an embryo in which all the important organs of the adult are mapped out before the lower pole is even invested with cells. Finally in Amniota (reptiles, birds, and mammals) the lower pole of the egg after all the yolk has been absorbed from it, is torn from the rest of the embryo at birth and cast off as a useless embryonic membrane.

In the earlier article a strong attempt was made to show that the primitive germ-layers do not correspond to one another in different eggs; in a word, that the same name has been given to different things. Some of the arguments adduced are the diverse origins of the mesoderm in various animals and the alleged origin of the epithelium of the alimentary canal of insects and some other Arthropoda from the ectoderm. The result of the labours of embryologists during the last 15 years has been to establish the universal homology of the germ-layers on an ever firmer basis, and to show that the difficulties alluded to were based on faulty observations.

If, for instance, we define the mesoderm as the wall of the coelom, then it is found that this organ originates in one of two ways, viz. either as a pouch or a mass of cells. The pouch (recognizable in Chaetognatha, Brachiopoda, Echinodermata, Enteropezusta and the lowest Vertebrata) quite clearly originates as an outgrowth from the endoderm; the mass of cells can be traced back to its source in one large cell, the mother mesoderm-cell. This cell, as was first shown by Shearer<sup>3</sup> in the annelid *Hydroides* and by Conklin<sup>4</sup> in the mollusc *Crepidula*, originally forms part of the wall of the archenteron and its ejection from this wall is evidently a modification of the more primitive method of coelom-formation by the outgrowth of a gut-pouch. Attempts which have been made by Meissenheimer<sup>5</sup> and Harms<sup>6</sup> to show that in Mollusca the coelom originates from cells budded from the ectoderm are based on obvious blunders in missing out stages in reconstructing the filiform form that must be the source of error in embryology. Later workers have exposed this error and have shown that in the Mollusca, with which Meissenheimer and Harms dealt, the mother mesoderm cell gives rise to the pericardium which is representative of the coelom in these animals. We have already alluded to the presence of mesectoderm in Annelida and Mollusca; this gives rise to some superficial muscles, but to confound this with the coelomic wall and its derivatives by calling both mesoderm and then to complain that the mesoderm is not an homologous structure in various groups of animals is to introduce a perfectly gratuitous confusion.

We may now turn to the alleged origin of the gut epithelium of certain Arthropoda from the ectoderm. In the earlier article the statement was made that in the embryo of that most primitive of all land Arthropoda *Peripatus* there is a large slit-like blastopore which later

<sup>3</sup> C. Shearer, "On the development and structure of the Trochophore of *Hydroides*," *Quart. Journ. Micr. Sci.*, vol. xlii. (N.S.), 1913.  
<sup>4</sup> Conklin, "The Embryology of *Crepidula*," *Journal of Morphology*, vol. xlii., 1907.

<sup>5</sup> Meissenheimer, "Entwicklungsgeschichte von Dreisensigen polymorpha," *Zeitschrift für wissenschaftliche Zoologie*, vol. lxxix., 1907.  
<sup>6</sup> Harms, "Postembryonale Entwicklungsgeschichte der Uniofischer," *Zool. Jahrbücher (Abt. für Ontogenie)*, vol. xxviii., 1909.

<sup>1</sup> H. Driesch, "Zur Analyse der Potenzen embryonaler Organellen," *Archiv für Entwicklungsmechanik*, vol. li., 1896.

<sup>2</sup> *loc. cit.*, p. 20.



becomes divided by a constriction into mouth and anus, and that a portion of the gut epithelium, viz. that forming the midventral portion, is formed from ectoderm turned in round the edges of the slit. It is practically certain that this last statement also rests on an error of observation. In the primitive annelid *Polygordius*, Woltereck<sup>1</sup> has described a similar slit-like blastopore and he has followed the process of its closure in great detail describing the division of every cell involved. In this case the midventral epithelium of the gut is formed by the union of endoderm cells lying at the sides of the blastopore—whilst the ectoderm cells lying in the blastopore lips by their union reconstitute the midventral skin. No reasonable doubt can be entertained that a renewed investigation with a more modern technique would show that this is also true of *Peripatus*.

It must never be forgotten that embryological research is based on a comparison of embryos of different ages with one another—not, as would be the ideal method, on a continuous observation of the progress of one and the same embryo. It follows that too large an age-difference between the embryos examined may give rise to a totally wrong conception of the process which is taking place. So are to be explained the statements which crop up from time to time, such as those of Heymons<sup>2</sup> that the mid-gut of the higher insects is entirely formed from ectoderm, and of Watase<sup>3</sup> who made a similar assertion about the mid-gut of the cephalopod *Loligo*. Hirschler<sup>4</sup> has shown how the error of Heymons originated, and Watase has been corrected by Faussek<sup>5</sup>; and should further statements of this kind occur in the literature the strong presumption is that they also are founded on mistakes.

**Organ-forming Substances.**—We have arrived at the conclusion that the establishment of the validity of the germ-layer theory is one of the great achievements of embryological research, and we now turn to the question of how the differences which distinguish the layers from one another are brought about. We have learnt that in primitive alicathal eggs like those of Echinodermata all portions of the blastula wall are alike in their potencies and that the differentiation of ectoderm from endoderm only begins when the first traces of gut-formation are visible. We have likewise learnt that all parts of the primitive gut or archenteron are alike in their powers, and that the separation of endoderm from mesoderm only becomes apparent when the first indication of the coelom appears. But this progressive differentiation of the embryo might be due to a differentiation of the nuclei of various regions or of the cytoplasm or of both. We have, however, learnt from the development of the polyspermic frog's egg that there is a strong presumption that the nuclei of the embryo are alike in their nature and that the differentiation of the layers must be due to the separation of organ-forming cytoplasmic substances from one another. This conclusion is confirmed by a large number of observations on many different kinds of eggs; a few of the more striking may be given here.

Hertwig<sup>6</sup> allowed frog's eggs to develop under pressure between glass plates and in capillary tubes. Under these circumstances the divisions took place by planes normal to the pressure and flat plates and rows of cells were produced. When the pressure was removed, however, these deformed embryos recovered, multiplication of cells took place and the normal form was regained and normal development proceeded. It was easy to show that nuclei which under undisturbed conditions would have occupied certain definite regions of the embryo had been forced into quite other regions, and yet perfectly normal embryos resulted. Hertwig concludes that the nuclei could be juggled about like a handful of balls without affecting the formation of the embryo.

In many eggs the differentiation of the layers is indicated at a far earlier period than that at which it occurs in the eggs of the Echinodermata or even of the lower Vertebrata like the frog. The egg of the ascidian *Cynthia parvula* which has been studied in great detail by Conklin<sup>7</sup> may be adduced as an example. This egg when it develops becomes converted into an elongated blastula consisting

of few cells; this blastula changes into a gastrula in the typical way, and though no distinct coelomic pouches are formed large portions of the archenteric wall are directly converted into muscle which lie at the sides of the tail of the tadpole-like larva. In the species the nucleus of the unripe egg is as usual a vesicle filled with fluid (the so-called germinal vesicle). The cytoplasm contains numerous yolk globules of a slaty-blue colour and also large yellowish globules which are concentrated in its superficial layer. When the maturation divisions of the nucleus occur the nuclear wall is dissolved and the fluid contents escape and form a cap of clear material at the animal pole of the egg. When fertilization takes place profound rearrangements of the substances in the cytoplasm are effected. The yellow globules stream downwards to meet the spermatazoa which enters at the vegetative pole, and they finally form a vescent layer of yellow material round the lower pole of the egg. As the egg develops first into a blastula and then into a gastrula, and finally into the characteristic ascidian tadpole, it becomes evident that the clear substance forms the ectoderm, the slaty-blue material the endoderm, whilst the yellow material forms the masses of mesoderm which give rise to the tail muscles. When the egg is in the four-cell stage the yellow material is confined to the two posterior cells; if one of these be killed the remainder of the egg will give rise to a larva with muscles only on one side of the tail. That the nuclei have nothing to do with this separation of substances is shown by what occurs at the lip of the blastopore. Here we find an arc what Conklin calls "neurochordal" cells. Each of these has of course a single nucleus, but the cytoplasm of each consists of zones, one clear and one slaty-blue. At the next division two daughter cells are produced from each neurochordal cell; one of these contains the clear substance and is added to the nerve plate which is a part of the ectoderm; the other is composed of the blue substance and forms part of the notochord which in *Cynthia* as in other Vertebrata is a derivative of the endoderm.

From this development we conclude that the germinal layer in their origin to the segregation of cytoplasmic substances in the growing egg; that these substances assume their final arrangement under the influence of the spermatozoon, which thus on its path to meet the female pronucleus determines the symmetry of the embryo. Brachet<sup>8</sup> has shown that this is also true of the frog's egg. It was for long a puzzle why competent observers like Roux<sup>9</sup> and Hertwig<sup>10</sup> should differ so profoundly on the results of killing one of the first two blastomeres of the frog's egg. Roux asserted that the surviving blastomere gave rise to a half blastula which developed into a half tadpole, whilst Hertwig maintained that it tended to form a normal tadpole, being only impeded in its development by the mass of dead material constituted by the other blastomere. Brachet has shown that he is right, for the plane separating the first two blastomeres does not in any means coincide with the future median plane of the embryo, but may make any angle up to a right angle with it. If it coincides with this plane by killing one blastomere Roux's result is obtained; if it is oblique the result accords with Hertwig's researches.

Thus the potency of each of the first two blastomeres of the frog's egg depends entirely on the cytoplasm it happens to include and in no way on the nucleus. Brachet<sup>11</sup> has shown that the fixing of the median plane of symmetry in the frog's tadpole, as in the ascidian tadpole, is effected by the spermatozoon. As the spermatozoon penetrates the egg in its path towards the female pronucleus it leaves behind a trail of pigment which persists for a considerable time and can be detected at a much later period in the development of the egg. It is found that on the opposite surface of the egg to that at which the spermatozoon enters it, there is formed the so-called "grey crescent." This is in reality the upper lip of the blastopore; it is here that the differentiation of ectoderm from endoderm begins. Therefore we conclude that the arrangement of the organ-forming substances in the frog's egg is caused by the spermatozoon.

In the mollusc *Dentalium* when the egg has reached the four-cell stage one of the blastomeres emits a protuberance termed the "yolk-lobe" or "polar lobe." This lobe is devoid of a nucleus and before the attainment of the eight-cell stage is re-absorbed into the blastomere. Nevertheless, if this lobe be cut off, the remainder of the egg develops into a larva which is fatally devoid of mesoderm.

That the materials which form the basis of the different substances embodied in the germinal layers are formed in the growing egg under the influence of emissions from the nucleus is rendered certain first by the close relationship of the nucleus to assimilation and secondly by the fact (see CYTOLOGY) that the nucleolus of the unripe egg breaks up into fragments and is extruded into the cytoplasm. It is, however, a surprising fact that the nuclei of the segmenting egg are alike and apparently without influence on the differentiation of the primary organs. In fertilization a second nucleus of alien origin is introduced and portions of this nucleus, as we have already seen, are

<sup>1</sup> Woltereck, "Beitrag zur praktischen Analyse der Polygordienentwicklung." *Archiv f. Entwicklungsmechanik*, vol. xviii., 1903.

<sup>2</sup> Heymons, "Über die Bildung der Keimblätter bei den Insekten." *Sitzungsber. der Preussischen Acad. der Wiss.*, vol. i., 1894.

<sup>3</sup> Watase, "Observations on the Development of Cephalopods." *Studies from the Biol. Lab. Johns Hopkins Univ., Baltimore.*, vol. vi., 1888.

<sup>4</sup> Hirschler, "Die Embryonalentwicklung v. *Donacia classipes*." *Zeitschrift für wissenschaftliche Zool.*, vol. xxii., 1909.

<sup>5</sup> Faussek, "Untersuchungen über die Entwicklung der Cephalopoden." *Mitteilungen a. d. Zool. Station zu Neapel*, vol. xiv., 1920.

<sup>6</sup> Hertwig, "Ueber den Werth der ersten Furchungszellen für die Organbildung des Embryos." *Archiv f. mikroskopische Anatomie*, vol. xlii., 1893.

<sup>7</sup> Conklin, "The Orientation and Cell-lineage of the Ascidian Egg." *Journ. Acad. Sciences, Philadelphia*, Series 2, vol. xiii., 1905.

<sup>8</sup> Brachet, *loc. cit.*

<sup>9</sup> Roux, "Über das entwicklungsmechanische Vermögen jeder der beiden ersten Furchungszellen des Eies." *Verhandlungen zu anatomischen Gesellschaft*, 1892.

<sup>10</sup> Hertwig, "Über den Werth der ersten Furchungszellen für Organbildung des Embryos." *Archiv für mikroskopische Anatomie*, vol. xlii., 1893.

<sup>11</sup> Brachet, *loc. cit.*

incorporated in all these "segmentation" nuclei. Now it is common knowledge that the influence of the father is as potent as that of the mother in heredity and therefore there must arrive a period of development at which the nuclei again influence the cytoplasm.

An attempt to determine this period was made by the writer by fertilizing the eggs of *Echinocardium* with the sperm of *Echinus*. As we have seen, the result of this cross is in most cases to produce cytolytic of the egg, but in a minority of cases a hybrid develops.

The egg of *Echinocardium* is oval whereas that of *Echinus* is spherical and the shape of the blastula of each species follows that of the egg. The blastula of the hybrid is oval, like the maternal blastula, and the gastrula is also like that of *Echinocardium*. But the typical larva (the four-armed echinopluteus) resembles in several points the larva of *Echinus*; in the vast majority of cases it is totally devoid of a large aboral club supported by a special skeleton which is characteristic of the larva of *Echinocardium*. It is clear therefore that at this stage the paternal nucleus is influencing the structure of the organism. When the eggs of *Echinus* are fertilized with sperm of a still more divergent character, such as that of the ctenoid *Antedon*, a hybrid occasionally develops as far as the gastrula stage, but it always resembles the larva developed from the normally fertilized egg in every detail and shows no trace of paternal influence.

**Nuclei and Cytoplasm.**—We are thus led to the conception of an intermittent action of the nuclei on the cytoplasm, and in this it seems as if we had reached the deepest point to which analysis of development will lead us. Perhaps it would be more accurate to speak of an intermittent reaction between cytoplasm and nucleus, for in some embryos there is evidence that the nuclei undergo alteration as development proceeds. It is on cases like these that Weismann's theory of development was founded. According to this theory, as growth proceeds, differential division of the nuclei takes place, some becoming specialized as ectodermal nuclei, others as endodermal nuclei and so on, whilst some retain the constitution of the original zygote nucleus; these last give rise by division to others like themselves which eventually engender the nuclei of the germ cells. The lineage or line of descent leading from these germ-cell nuclei back to their ancestors amongst the nuclei of the first blastomeres is termed the "germ-track." Now in the Nematode worm *Ascaris megalocephala* the zygote nucleus contains only four chromosomes, but as the egg divides into blastomeres, the nucleus of one blastomere after another undergoes the change termed *diminution of the chromatin*. This change involves the ripping-off of the ends of the chromosomes, and these portions are ejected into the cytoplasm and are absorbed; the remainder of each chromosome becomes fragmented into a large number of minute granules. These granules act as chromosomes in the next nuclear division. The nucleus of one blastomere remains exempt from this change and this blastomere eventually gives rise to the genital organs.

Boveri<sup>1</sup> has shown that the fact that one nucleus undergoes diminution of the chromatin whilst another does not is not the consequence of a differential division of the mother nucleus of them both, but is due to the fact that one nucleus takes up its position in a region occupied by a particular cytoplasmic substance. This he proves in two ways, viz. (1) by considering the case of eggs fertilized by two spermatozoa, and (2) by the results obtained by subjecting eggs about to segment to the action of strong centrifugal force.

In doubly fertilized eggs the extra spermatozoon forms an independent nucleus whilst the other fuses with the female pronucleus to form the zygote nucleus. The first division of the egg results in the formation of four nuclei and four blastomeres. In the development of the normally fertilized egg one of the two first nuclei undergoes diminution, and the cell containing it gives rise to a large part of the dorsal ectoderm; the other nucleus remains undiminished and amongst the progeny of the cell containing it are found the genital cells. Now amongst the four cells produced by the division of the doubly fertilized egg, three may contain nuclei which undergo diminution, and one may remain undiminished—in such cases the egg develops into a single embryo with an unusually abundant ectoderm. In other cases only two of the nuclei undergo diminution—such eggs form twin embryos of normal aspect; whereas in still other cases one nucleus alone may undergo diminution and in these cases a monstrous triple embryo is formed. These differences are accounted for on the assumption that one region of the egg contains a substance which induces diminution and one, two or three nuclei of the doubly fertilized egg may be in it.

When eggs about to segment are exposed to the action of long-continued and intense centrifugal force the plane separating the first two blastomeres will in some cases be found to lie along a radius of the circle of rotation, and in these cases a small mass of material will be found to be ejected from the egg which then becomes divided

into two appreciably equal and similar blastomeres, the nucleus of neither of which undergoes reduction. This suppression of reduction must be attributed to the even distribution of the cytoplasmic materials under the stress of the centrifugal force, so that no region of the egg contains more of the peculiar substance than any other. Diminution of the chromatin apparently results from the action of an excess of this substance on any nucleus contained in it.

**Regeneration.**—In the phenomena of regeneration and of budding we meet with evidence of the renewed influence of the nuclei in causing the formation of cytoplasmic substances.

We have already learnt that when one of the first two blastomeres into which a frog's egg divides is killed, the survivor frequently develops into a half gastrula which may even grow into a half tadpole. Roux,<sup>2</sup> however, has shown that if this half tadpole survives it becomes a whole tadpole by what he calls the "post-generation" of the missing half. This is effected by the multiplication of the cells lying at the edges of the half embryo. The nuclei increase in number and confer on the cytoplasm in their neighbourhood new powers. In this case it might be objected that each kind of tissue in the old half gives origin only to the same kind of tissue in the new half. But Morgan<sup>3</sup> has shown that if the head (including the pharynx) of the annelid *Nereis* be cut off, a new head with pharynx will be regenerated from the stump; whereas, however, the original pharynx was formed by an intucking of ectoderm, the new pharynx is formed by an outgrowth from the endodermal tube in the stump. The new powers thus conferred on the cytoplasm of the endodermal gut can only be explained as the result of the calling-forth of new potentialities in the nuclei lying in the cut edge. More remarkable evidence still has cropped up in connexion with the regeneration of the lens of the eye of the newt. In the embryo the lens is formed as a thickening of the ectoderm on the side of the head. But if the original lens be torn out, a new lens is developed either from the edge of the iris or of the retina—tissues that have no connexion with the skin of the head. Some try to meet this difficulty by the phrase that in these cases the organism acts as a whole, independently of the germ-layers into which we analyse it. But what meaning can be attached to this phrase, except that the organism under different circumstances uses different means in order to effect a restoration of its integrity, it would be difficult to say. In fact we approach very closely to the celebrated "entelechy" of Driesch; that is an indwelling "something" in an organism which strives to realize a purpose.

**Vitalism; and the Theory of an Entelechy.**—It may be argued that such an idea is unscientific, because it introduces "vital force" and similar mystical ideas amongst our biological conceptions. It may be answered that in the last resort *all explanation is comparison*, and that those who reject vitalism seek to compare all the activities of living beings to phenomena which go on outside the body in test-tubes. But this is equivalent to referring all the phenomena of life to structure, in other words the juxtaposition of definite chemical substances, in a definite spatial arrangement; in regeneration, however, we encounter phenomena where structure appears to be irrelevant. If we are to do justice to such phenomena we must have some working hypothesis similar to that of Driesch. Whether the assumption of an "entelechy" is better or worse than the statement that all the nuclei in the body are totipotent and that varying potentialities are called forth seems to be a matter of taste.

**Budding.**—Regeneration is in many respects akin to budding, since buds in many cases may be regarded as portions of the mother organism restored after natural amputations.

In the growth of buds we often meet with a wide divergence between the materials used to build up certain organs, and those used to construct similar organs in the embryo. To give an example—the bud of the ascidian *Botryllus* begins its existence as a little two-layered vesicle very similar to the gastrula of the same species. But in the embryo the central nervous system is developed from the outer layer as it is in all other Vertebrata. In the bud, on the contrary, it is formed as an outgrowth from the inner layer. Hjort,<sup>4</sup> who described this phenomenon, suggested as the explanation for it the fact that the outer layer of the bud is an outgrowth of the adult maternal ectoderm, which is specialized for the secretion of the cellulose "mantle" and not sufficiently plastic to be turned into nervous tissue. This is only another way of saying that the formative nuclei act differently in different cases and distribute the organ-forming cytoplasmic substances in a different manner in the bud from their arrangement in the egg.

**One or Two Embryos.**—The primary organs, i.e. the germ-layers, are the material out of which the higher organs are built up, and one of the most remarkable of recent discoveries in embryology is the fact that the question of whether this material

<sup>1</sup> E. W. MacBride, "Studies on the Development of Echinoidea," (II) "The early larva of *Echinocardium cordatum* and the result of crossing this species with *Echinus esculentus*," *Quarterly Journ. Micro. Science*, vol. lviii., 1912.

<sup>2</sup> A. Weismann, *The Germ-Plasm. A Theory of Heredity* (1893).

<sup>3</sup> Th. Boveri, "Die Potenzen der Ascaris-Blastomeren bei abgeänderter Furchung," *Petschrift zum 100 ten Geburtstag Richard Weggs*, vol. iii., No. 8, 1910.

<sup>4</sup> Roux, *loc. cit.*

<sup>5</sup> Morgan, *Regeneration* (1901).

<sup>6</sup> H. Driesch, *Zwei Vortrage zur Naturphilosophie* (1910); see also Gifford lectures for 1907 and 1908.

<sup>7</sup> Hjort, "Germ-layer Studies based on the Development of Ascidiaceans," *Zool. Resultat Norwegian N. Atlantic Exped.* (1896).

shall be used to build up one embryo or two depends on the special relations which these primary cytoplasmic substances sustain to one another.

If the eggs of a frog be placed dry on the surface of a slide with their animal poles uppermost and fertilized in that position by the addition of small quantities of the fluid extracted from the seminal vesicles of a male; if then another slide be placed on top of them and the two slides clamped together by rubber bands; if when the eggs have divided into two blastomeres the whole preparation be inverted and left in water in a shallow dish for five or six days tadpoles with two heads or two tails will be developed. The materials in the unsegmented egg are of different specific gravities; the first furrow often (see above) divides them into two symmetrical halves; when the two-cell stage is inverted they tend to rearrange themselves in each cell in the same manner as they would have in the whole egg had it been inverted. Nothing has been added or taken away, yet the altered position of the materials in each cell has led to the formation of two organs where normally only one would have been formed. In the case of the newt's egg a similar procedure leads to the formation of two complete embryos, whilst if the blastula of the newt be constricted longitudinally by a hair a two-headed monster is formed. When a lizard's tail is broken off, if the little regenerating bud which forms at the wounded surface be indented the animal will regenerate two tails instead of one.

**Internal Environment.**—When the higher organs begin to develop we can in many cases prove that the whole course of their growth is governed by what may be called their internal environment, i.e. by influences emitted by other organs.

This may be clearly seen in the development of the common sea-urchin *Echinus miliaris*. The "echinopluteus" larva of this species is a transparent bilaterally symmetrical free-swimming creature. It is provided with a complete alimentary canal consisting of oesophagus, stomach and rectum, and at the sides of the oesophagus are situated two flattened coelomic sacs. As development proceeds each sac becomes divided into anterior and posterior portions, and the latter move backwards so as to be pressed against the stomach. Still later from the posterior end of the left anterior sac a little bud termed the "hydrocoele" grows out. This is the rudiment of the water vascular system of tubes in the adult. The ectoderm lying over this bud becomes pressed so as to form a sac (the "amniotic cavity") from the floor of which grow up the spines which will cover the test of the future sea-urchin.

The hydrocoele bud overlaps the front end of the left posterior sac, and from this part of the sac there grow out five pockets from which will be developed the dental apparatus—the so-called "Aristotle's lantern." From the outer wall of the right posterior coelomic sac cells are given off from which are developed a pair of "pedicellariae" (pincer-organs) which will be situated on the upper surface of the future urchin. If we now allow the young larvae at the time the coelom is being formed to grow in hypertonic water, then many of them will develop from the right anterior coelom a second hydrocoele bud. If this bud develops—and it does so if plentiful nourishment be supplied to the larva—then a right amniotic cavity is formed from the overlying ectoderm, whilst the right posterior coelom gives rise to a second Aristotle's lantern. If the development of the second hydrocoele bud be slow then one or even two pedicellariae may be formed on the right side as in normal larvae, but if it be rapid the formation of pedicellariae may be inhibited altogether. If after the bud has appeared the larva is nearly starved for a time, both this abnormal bud and the normal hydrocoele may remain small and undeveloped, and then pedicellariae may be formed on the left side as well as on the right.

We conclude from these facts that the hydrocoele bud tends to inhibit the formation of pedicellariae on its own side of the larva but to cause their production on the opposite side, and we see further that the right hydrocoele bud can totally alter the development of the right side of the larva, forcing the right ectoderm to form an amniotic cavity and the right posterior coelom a dental apparatus.

Another still more striking case of the influence of the internal environment is afforded by the results of experiments performed on the tadpole of the frog. The vertebrate eye consists of two main parts, viz.: (a) the retina, formed as an outgrowth from the brain; and (b) the lens, formed as a thickening of the ectoderm of the side of the head. If before the lens is formed the skin of the head of a tadpole be slit open and the retina cut off from the brain and pushed back till it occupies a position in the region of the shoulder or even farther back, and the slit in the skin sewn up, then the tadpole will recover; the cut-off retina will continue to live and grow in its new position, and it will force the ectoderm covering it to form a lens—although never in the history of the race has a lens been normally formed in this position. Numerous other similar instances could be

adduced—did our space permit of it—suggesting the conclusion that in many embryos the primary organs are indifferent material and that the manner in which the secondary organs will develop out of them is fundamentally a matter of their spatial relations.

**External Environment.**—We now approach the subject of the possible influence of the external environment on the course of development. In the earlier article the attention of the reader was called to the fact that development presents itself under two principal aspects, viz. the embryonic and the larval. In the embryonic phase the young organism is sheltered from the external world, either within an egg-shell or in the mother's womb, whereas in the larval phase it leads a free life, using its larval organs to seek its own food and escape its enemies.

It was further pointed out that if we compare two nearly allied animals such as *Salamandra atra* and *Salamandra maculosa*, in the first of which development is mainly embryonic whereas in the second it is largely larval, we arrive at the conclusion that the embryonic phase is secondarily derived from the larval phase, since the organs such as gills which are functionless in the embryo are functional in the larva. It was also pointed out that larval organs frequently resemble the adult organs of other animals of simpler and more primitive structure.

On these facts was founded the celebrated biogenetic law first enunciated by Haeckel<sup>3</sup> which affirms that "the embryo in its development recapitulates the ancestral history of the race." It is the law which provides a large part of the fascination of embryological research, but it was vigorously attacked in the earlier article and an effort was then made to show that it is not valid, since it was maintained that whilst it is true that larvae retain ancestral characters, the same is true of adults, and that larvae in their structure are not more reminiscent of the former history of the race than are adults.

Now the outcome of recent investigation has in large measure tended to restate the doctrine of recapitulation in its former position of preëminence, to show in fact that recapitulation forms the central thread in every life history, although it has been blurred and deflected by secondary influences, as indeed all believers in the biogenetic law have from the first admitted.

The first point to which we wish to direct the reader's attention is that larval and embryonic phases occur in all life histories. Every animal begins its existence as an egg which is quite incapable of feeding or of defending itself and this egg is always protected by an egg-shell although this shell may be very thin, and no animal upon leaving its early shelter and beginning to seek its own food attains at once the structure of the sexually ripe adult. Hence every animal in the course of its development may be said to pass first through an embryonic and then through a larval phase, although the latter phase may be very short and the difference in structure between the larva and the adult inconsiderable. Now, the larval phase being the later is the most recent addition to the life history and therefore the least likely to be modified by secondary factors; if therefore the biogenetic law be valid, it is the larval phase which will possess most ancestral significance. But in the earlier article attention is called to the fact that the identification of a larva as the representative of an ancestor must always be hypothetical because we have no direct knowledge of what the ancestor of any living animal was like. It behooves us therefore to look a little more closely at the reasons which actually do induce us to regard a given stage as ancestral.

First, it has been claimed quite recently that direct experimental proof of the validity of the biogenetic law has been obtained. Kammerer<sup>4</sup> placed young specimens of *Salamandra maculosa* which had just completed their metamorphosis in cages the floors and walls of which were coloured differently in different cases. The larva of this species has a skin of a uniform dark-greyish tint, but the skin of the adult is gaily coloured with bright yellow patches on a black background. The salamanders which were confined in cages having a floor of moist yellow loam and walls coloured yellow became yellow as they grew to maturity—a process which occupies between three and four years. The yellow patches, in a word, increased in number and size and tended to become joined together in bands. Those confined in cages with blackened walls and a floor of black garden earth became darker since the yellow patches dwindled in size. When the salamanders had attained sexual maturity and were allowed to spawn, it was found that the offspring of two which had been reared in yellow surroundings, if they continued to live in the

<sup>1</sup> E. W. MacBride, "The Artificial Production of Echinoderm Larvae with Two Water Vascular Systems," *Proc. Roy. Soc. (London)*, Series B, vol. xc., 1918.

<sup>2</sup> W. H. Lewis, "Studies on the Development of the Eye in Amphibia, I. The Lens," *American Journ. Anat.*, vol. iii., 1904.

<sup>3</sup> Haeckel, *Allgemeine Morphologie* (1866).

<sup>4</sup> P. Kammerer, "Vererbung erzwingender Farbveränderungen. IV. Das Farbleben des Feuersalamanders (*Salamandra maculosa*) in seiner Abhängigkeit von der Umwelt," *Archiv für Entwicklungsmechanik*, vol. xxvii., 1913.

same environment, became still yellower than their parents until the black pigment had been almost entirely displaced; whilst the offspring of two which had become darker, if reared in cages with black walls and floor, became practically completely black by the time they reached maturity so that they came to resemble the mountain species *Salamantra atra*. If, however, the offspring of two salamanders reared in yellow surroundings were allowed to grow up under black surroundings, they nevertheless for the first six months of their lives became progressively yellower; then and only then did the influence of the black environment begin to tell—the yellow patches became invaded by numerous small black spots and grew smaller. In short, the young recapitulated the process of "yellowing" that their parents had undergone.

If these results are confirmed the doctrine of recapitulation will change its status from that of an hypothesis to that of a proved fact, and further proof will be furnished that changes acquired by the individual in response to the demands of the environment are to a certain extent at least inherited.

**The Recapitulation Theory.**—Once we have grasped the mutual relationship of the embryonic and larval phases of development, indirect proofs of the reality of recapitulation begin to crowd in on us. If we find, for instance, one or two aberrant forms in an order or even a family the majority of whose members have a uniform type of structure, no reasonable doubt can exist that the ancestors of these aberrant forms had the typical structure of the group. If this conclusion be admitted and we find that the younger stages of the aberrant species also show the typical structure, does any one seriously question that these young forms recapitulate the history of the race? Two very striking instances of this kind have come to light within the group Ctenophora.

The typical Ctenophora are ovoid organisms of a glassy transparency which swim in a vertical position in the sea. Their locomotor organs are eight vertical rows of vibratile combs; each comb consisting of a short horizontal row of powerful cilia fused together at their bases. A certain creeping organism resembling a flat worm, named *Coleoplana*, had been believed by some zoologists to exhibit ctenophore affinities but its relationships were very obscure. Quite recently a Japanese zoologist<sup>1</sup> has described its development. Its larva is a small typical ctenophore with eight rows of perfectly formed combs; these it discards after swimming for a few hours—it sinks to the bottom and hatches out and gradually assumes the adult structure. Another extraordinary organism, named by its discoverer *Triadifella*,<sup>2</sup> was discovered amongst dredgings collected in the Arctic Ocean. This creature superficially resembled a sponge or an ascidian. It was gelatinous and sessile and seemed to consist of a pair of upright tubes like towers whence proceeded smaller tubes which rankled in its substance. In pockets connected with these smaller tubes were discovered groups of the larvae. These were small ovoid creatures of typical ctenophore structure with the eight vertical rows of combs.

If recapitulation of ancestral history forms an unquestionable element in the life history of some animals, is it not probable that it constitutes a factor in all life histories? To this question it seems to us only an affirmative answer is conceivable.

**Change of Habits.**—If we then regard the reality of recapitulation as proven we may now reflect on its meaning. We have seen that the recapitulatory element is most obvious in the latest larval stage of development, the most recently added page of the life history. Now the organs of the larva are adapted to its environment; therefore this environment in its broad outlines at least must represent the ancestral environment of the race.

The present condition of the race both as regards structure and habits has been produced as a consequence of migration from the original haunts of the race. Change of habits therefore reveals itself as the great driving-force in evolution, and change in habits usually means the choice of a different type of food.

We may conclude that the periods of life at which this change most frequently occurred was when the adult organs had developed but before sexual maturity had been attained—in a word, at the stage of what we may call the young adult. As one change of habits succeeds to another in the course of evolution, the life history is not lengthened in the same proportion, since the new phase takes the place of the sexual phase in the previous condition of the race. In some Crustacea, e.g. in the shrimp *Penaeus*, at least four larval stages are passed through before the

adult stage is attained, but in the majority of life histories when a new phase is added there is a tendency for some of the older phases to be pushed back into the embryonic period, so that as an animal passes from stage to stage in evolution it leaves behind a trail of stages at first larval and then becoming embryonic.

**Secondary Modifying Factors.**—We may now glance at the principal factors which modify and tend to obscure the recapitulatory factor. It is only possible to define these factors by a truly comparative embryology based on a wide survey.

One of these factors is "tachygenesis" or precocious development; that is to say, we find that organs originally developed as a response to the stimulus of a new environment come in course of time to be developed before the habits to which they correspond can be exercised—in fact acquired habits tend to become innate. Thus the young hermit crab when adult thrusts its abdomen into the cavity of a spirally coiled gastropod shell, and in this way imposes a twisted form on this part of its body. But if all such shells be removed from the hermit crab's neighbourhood at the time of its metamorphosis, it will still develop a curved abdomen although the extent of the curvature will be less than that which occurs normally. When the tadpole of the frog acquires limbs, these do not develop in the form of fins from which they have been undoubtedly evolved, but grow directly into the ordinary type of five-toed limbs, although webbs must elapse after their form is fully defined before they can function as the limbs of land animals. The tendency to hurry on development may be compared to the increasing facility with which a difficult operation is performed after long practice, but this tendency obviously tends to obscure the distinctive features of early development.

A second powerful modifying factor is the change from the larval to the embryonic phase, so far as the development of a particular organ is concerned. This change of phase is sometimes caused by an unfavourable alteration in the environment of the larva. It was actually effected artificially in the development of *Salamantra maculosa* by Kammerer.<sup>3</sup> This species is viviparous and normally gives birth to between 30 and 40 young which are provided with gill-slits and long gills and which live in the water for six weeks before they metamorphose into land animals. If the parents are exposed to successively colder and drier conditions, the number of young produced at a birth diminishes with each breeding-period, and these young are born at a progressively more advanced stage of development. If these young are reared to maturity under similar conditions of coolness and dryness, they will in turn give birth to young which will be still fewer in number than those produced by their parents and which are born at a still more advanced stage of development. The process goes on till only three or four are born at one time and these are provided with the nearest stumps of gills; such young never enter the water at all but at once take up the adult mode of life. This is the normal mode of development of *Salamantra atra*.

The change of phase from the larval to the embryonic type entails many other changes. The embryo must be fed and it obtains its food from one of three sources, (a) devouring its sisters; (b) secretions from the mother's womb; (c) inclusions of yolk in its own cytoplasm. When the embryo devours its own sisters, this, as in the case of *Salamantra atra*, may entail little change of structure because the habit is one recently acquired; but where, as in the case of the playhelminth worms, the habit is of old standing then the embryo may be distorted out of all recognition. In these worms one viable egg is shut up in a capsule along with thousands of small sterile ones; and it is difficult to find in the embryo any vestige of resemblance to the larva of these Playhelminths which lay their eggs singly.

When the embryo derives its nourishment from the mother's womb then it frequently develops organs of adhesion to the wall of this. To this category belongs the placenta which profoundly distorts the ventral surface of the human embryo; so that this surface gives rise to a treelike outgrowth whilst the dorsal surface is moulded into a ludicrously exact copy of the early tadpole of the amphibian.

When the embryo is fed by yolk, this, as we have already pointed out, modifies all the processes of development; cell division becomes slow and the cells produced few and large; and folding which plays a large part in the development of small asexual eggs, becomes impossible and is replaced by solid outgrowths of cells.

Still a third factor which tends to hide the recapitulatory element is the development of special larval adaptations. This occurs when the larva retains its free life but when its circumstances become changed. These special adaptations have been developed in thousands of insect larvae. So generally is this the case that Balfour<sup>4</sup> denied to these larvae any ancestral significance at all; but modern research has succeeded in revealing the original ancestral larval type beneath the secondary modifications.

All the evidence at our disposal points to the conclusion that the ancestors of insects were creeping myriapod forms—scavengers

<sup>1</sup> Taku Komai, "Notes on *Coleoplana bichi* and its development," *Annal des Zoologie Japonense*, vol. ix., 1920.

<sup>2</sup> Mortensen, "Ctenophora," *Danish Insect Expedition*, vol. v., No. 2, 1912.

<sup>3</sup> Kammerer, "Vererbung erworbener Fortpflanzungsapparaturen I & II. Die Nachkommen der spätgeborenen *Salamantra maculosa* und der frühgeborenen *S. atra*," *Archiv für Entwicklungsmechanik*, vol. xxv., 1908.

<sup>4</sup> Balfour, *Comparative Embryology*, vol. ii., p. 368, 1884.



which fed on the debris of both animal and vegetable nature in the undergrowth of primeval forests. Such is in fact the life of the lowest insects known to-day, some of which, such as *Machilis*, nourish themselves on the decaying sea-weed on the sea-shore, and retain throughout life vestigial limbs attached to the abdominal segments which aid them in their crawling movements. Now the myriapod or poly-pod larva survives as the caterpillar of the Lepidoptera and the primitive Hymenoptera. It is also found amongst the primitive Meroptera and amongst the may-flies (*Ephemeroptera*). These last-named insects were supposed to possess a larva showing great secondary modifications, for it is provided with leaf-like gills attached to its abdominal segments; but Heymons<sup>1</sup> has shown that these gills are nothing but modified abdominal legs. It is a curious fact that amongst the lower insects, such as the cockroach, this poly-pod stage is passed through during the embryonic phase of development. The reason for this change is that these insects lay their eggs in situations where a grub-like larva would perish, whereas the higher insects, in which the stage is larval, are gifted with instincts which lead them to lay their eggs in situations where an abundance of easily procured and easily masticated food is available and a scavenging existence like that of the ancestor is possible.

A fourth factor which modifies development, and which is potent in its effect although it is usually overlooked, is *loss of size in the larva as compared with the ancestor which it represents*. As conditions change and the larval life becomes more dangerous there arises a tendency in which we may trace the influence of tachygenesis to pass quickly through the larval stage and to metamorphose at as early a period of growth as possible into the adult condition. A consequence of this change is that the larva assumes a new relation to its environment, for many qualities of the surrounding medium, such as the viscosity and supporting-power of water, acquire an altered importance as the organism decreases in size. If the ancestral organs were reduced in the same scale as is the whole body of the larva, this would in many cases result in their becoming incapable of being used. As a consequence we find that in many cases where the ancestor had a series of organs, this series is represented in the larva by fewer members or only one member of larger relative size, and that where in the ancestor there was a pair of organs there is frequently only one in the larva, but this is on a larger scale than the rest of the body. If we now select a few examples to illustrate this principle, we may consider the free-swimming larva of that most primitive of all vertebrates *Amphioxus*. This larva has only a single series of gill-slits which are so enlarged as to occupy the whole ventral surface of the body. If the double series of slits, which the ancestor in common with all other fish possessed, had been developed in the larva, they would necessarily have been of such minute size that the capillarity of the water would have prevented them from being functional. Similarly there is no doubt that the eyes of vertebrates were from the beginning paired structures, but they are represented in the ascidian tadpole by a cup-like outgrowth of one side of the brain. Again no serious doubt can be entertained that the primitive arthropod was evolved from a long many-segmented annelid with flexible parapodia. But the most primitive larval form of the Crustacea is the nauplius which is a little, oval, unsegmented creature with but three pairs of legs. The existence of this larva, was a great stumbling-block to the earlier embryologists. It seemed to indicate that the Crustacea must have been derived from an unsegmented animal, totally distinct from the ancestor of other Arthropoda, for the progenitor of these must have been long and segmented since the embryos of all these Arthropoda have many segments. But if we look at the nauplius larva from the standpoint of function rather than of structure we have no difficulty in seeing in it the recapitulation of the first stage in the "arthropodization" of the annelid. This step was a change of habits which consisted in using the foremost parapodia as organs to propel the animal and as organs to seize food. As a consequence in the front of the body the gut-stiele was thickened and the "arthropodous" type of limb produced, whilst in the rest of the body the annelid condition of affairs persisted as indeed it may be almost said to do in the posterior portions of the bodies of this most primitive of Crustacea, the long-bodied Phyllopoeta such as *Aurelia*. Once begun in front, this "arthropodous" modification was gradually propagated backwards so as to involve the hinder segments of the body and in this way the higher Crustacea were evolved. In the nauplius larva, the anterior arthropodized portion of the ancestor with its appendages is alone represented; the hinder annelid portion in which function was less intense and less important is not developed.

One last instance of the principle may be adduced which we select from the embryology of the higher vertebrates. In the development of those types of Vertebrata in the life history of which there is a long larval phase (Cyclostomata, dipnoan, "ganoid" and teleostean fish, Amphibia), a larval excretory organ termed the *pronephros* makes its appearance. Its duct later becomes the duct of the permanent kidney, but the pronephros itself consists of very few tubules and these originate from the wall of the general body cavity and not, as do the tubules of the permanent kidney, from special sacs

<sup>1</sup>R. S. Heymons, "Über die Lebensweise und Entwicklung von *Ephemera vulgata*," *Sitzungsberichte der Gesellschaft der Naturforschenden Freunde zu Berlin* for 1896.

(the malpighian capsules). The earlier workers regarded the pronephros as a last trace of a primitive excretory organ of quite different structure to the permanent kidney by which it is later superseded. The works of Hatta<sup>2</sup> on the development of the lamprey and of Kerr<sup>3</sup> on the development of the Polypterus have proved that the pronephros is nothing more than the foremost section of the permanent kidney, early called into action and enlarged whilst the hinder section of the metamorphically repeated series of tubes of which the kidney consists remains undeveloped. These investigators have further proved that the portion of the general body cavity from which the pronephric tubules arise consists of several malpighian capsules fused together and secondarily communicating with the general body cavity.

*Life History of Animals.*—It might be supposed that with so many modifying factors at work it would be a hopeless task to attempt to disentangle the recapitulatory element from them, and that therefore the ancestral history of animals except in its latest, and least modified chapters would remain a closed book. But when we recollect that the life history of every species constitutes a separate edition of this history, and that the modifying factors have affected no two of them to the same extent, it becomes evident that comparative embryology built on a broad basis can attack the problem with a fair prospect of success.

Bearing in mind the priority of the larval over the embryonic phase, and beginning therefore our survey with the larvae of the simplest metazoa, we are able to recognize the first step in the evolution of the metazoön from the protozoa in the blastula, the hollow ball of cells which may be regarded as representing a colonial protozoön-like the living *Volvox*. This stage was followed by the formation of a gut by the intucking of one side of the ball, and this second step is represented in the life histories of all the lower and simpler animals by the gastrula stage. Following on this stage came the formation of the coelom as a series of pocket-like outgrowths of the gut, and the change of the single opening of the gastrula, the blastopore, into two openings which became the mouth and the anus by the constriction of its middle portion.

It has been possible to show that two groups so utterly diverse in appearance as the Annelida and the Mollusca have originated from a single group of free-swimming ancestors represented by the trochophore larva, and since Arthropoda are admitted to all to be descended from Annelida this conclusion involves the ancestry of four-fifths of the animal kingdom.

We can form a very plausible guess as to the nature of the divergence of habits which led to the differentiation of the Annelida and Mollusca from one another: The original stock was free-swimming but both groups derived from it are typically bottom-dwellers. Two modes of seeking their food were open to them; they could either glide over the bottom by means of their cilia as young Gastropoda and Lamellibranchiata still do, or they could burrow into it. The first led to the evolution of Mollusca, the second to that of Annelida.

Two other groups of very diverse structure, which embryology has given strong reasons for believing to have been derived from a single race, are the Echinodermata and the Vertebrata. The lowest form which gives distinct evidence of the vertebrate affinities is the worm-like creature *Balanoglossus*. The larval form of *Balanoglossus* is a free-swimming organism named *Scyphozoa* which shows the close resemblance to the typical larva of Echinodermata, the *Scyphozoa*. The recognition of this affinity has assisted in the elucidation of a difficult subject to which considerable space was devoted in the 11th ed., viz. the origin of the central nervous system.

It is characteristic of the most primitive Annelida and Arthropoda that this system develops as a ring round the blastopore and an endeavour was made in the 11th ed. to prove that this was originally true of vertebrate embryos also. But it is a peculiarity of the vertebrate-echinoderm alliance which is still unexplained that in these the blastopore gives rise to the anus alone, whilst the mouth is formed as an apparently independent perforation at a considerably later period of development. A long succession of embryologists with their eyes fixed only on the embryos of Annelida, Arthropoda and the higher vertebrates, have held that the vertebrate mouth is a new structure formed by the fusion of a pair of gill-slits and have prosecuted vain searches for traces of the old mouth. Others have imagined that the mid-dorsal line of the vertebrate embryo along which the nerve-cord develops corresponds to the line joining mouth and anus in the arthropod, the line in fact which is occupied by the slit-like blastopore in *Paripatus*. They hold that the nervous system of the vertebrate originally extended round the front end of

<sup>2</sup>Hatta, "The Development of the Renal Organs in the Lamprey," *Journ. Coll. Sci. Imp. Univ. Tokio*, 1912.

<sup>3</sup>Kerr, "Vertebrata with the exception of Mammals," *Treatise of Embryology*, vol. i., pp. 223-237 (1919).

the embryo so as to include the mouth. But the independent and late development of the mouth is an assumed feature in the echinoderm larva as in the vertebrate embryo and there are no gill pouches. In the echinoderm on which we could fall back to explain the phenomenon. Further, in the adult echinoderm the whole of the ectoderm is underlain by a nervous plexus of which the central nervous system is only a specialized and intensified portion, and the same thing is true of the anterior region of *Balanoglossus*. It is therefore futile to look for exact correspondence between the central nervous systems of two stocks which diverged from one another at such a primitive level as did the Vertebrata and the Annelida. In fact the descendants of the trochophore stock (Amelida, Arthropoda and Mollusca) on the one hand and the Original Vertebrata on the other seem to have adopted two different modes of life which led to concentrations of the nervous system in different parts of the body. The trochophore stock took to crawling on their ventral surfaces and their locomotor organs were developed in this region of the body and in connexion with them the motor ganglia which make up the spinal nerve-cord; whereas the vertebrate stock took to swimming by lateral blows of their blade-like bodies and this led to the concentration of the central nervous system in the mid-dorsal line.

Enough has been said to give evidence for our belief that the most recent research has tended to reestablish the recapitulatory element as the fundamental factor in life-history, and if this be admitted the study of comparative embryology opens up a means of investigating the early history of life at a stage long before it left evidence of its existence in the stratified rocks; and, further, the acceptance of recapitulation involves a conception of the laws of heredity entirely distinct from and supplementary to that suggested by Gregor Mendel and his followers.

BIBLIOGRAPHY.—F. R. Bailey and A. M. Miller, *Textbook of Embryology* (1909); F. M. Balfour, *A Treatise of Comparative Embryology*, vols. i. and ii. (1881); L. Guérin and Les Facteurs de l'Ontogenèse, *Encyclopédie Scientifique*, Paris (1916); J. C. Heister, *Textbook of Embryology for Medical Students* (1907); H. Driesch, *The Science and Philosophy of the Organism*; Gifford lectures for 1907 and 1908; O. Hertwig, *Lehrbuch der Entwicklungsgeschichte des Menschen und der Wirbelthiere*, Jena, 1890-1920; J. W. Jenkinson, *Vertebrate Embryology* (2nd ed. 1921), *Experimental Embryology* (1909), *Three Lectures on Experimental Embryology* (1917); J. Graham Kerr, *Textbook of Embryology*, vol. ii., *Vertebrata* (*embryology of the Invertebrates*, translated by E. Mark, Ph.D., and W. McM., Woodworth (1895); Lillie, *The Development of the Chicks* (E. W. MacBride, *Textbook of Embryology*, vol. 1., *Invertebrata* (1917); A. Milnes Marshall, *Vertebrate Embryology* (1893); T. H. Morgan, *Regeneration* (1901).

ENCEPHALITIS LETHARGICA (from Gk. *ἑνκεφαλίτις*, a portion of the brain, and *λεθάργος*, forgetful), a specific infectious disease of the nervous system, of which the most frequent, though by no means invariable, symptom is drowsiness or lethargy; often associated with paralysis of the muscles of the eye, producing diplopia or double vision.

In recent years this disease first appeared in epidemic form in Austria in the winter of 1916 and was described and named by C. von Economo in Vienna in 1917. It reappeared in the following winter, and was recorded in France in March 1918 by A. Netter. In England it was first recorded in April 1918, independently by Wilfred Harris and A. J. Hall. These earlier epidemics were all recognized by the combination of lethargy and diplopia. Subsequently the same seasonal incidence has prevailed, the number of cases diminishing in summer and increasing in winter and spring. In the United States it was reported in March 1919, the epidemic having spread from east to west.

The literature of medicine has been ransacked to ascertain whether or not previous records exist of the occurrence of the characteristic combination of symptoms. In 1830 a small epidemic occurred in North Italy, and later in Austria and other countries, which may be accepted as Encephalitis Lethargica. At the time it was known as Noma. It attracted little attention. The evidence for sporadic cases since then is doubtful.

Previous records are all doubtful. Hippocrates, Sydenham and other less-known authorities have described conditions which may or may not have been Encephalitis Lethargica. Stahl in 1779 recorded more fully an outbreak characterized both by lethargy and diplopia, and with other very suggestive symptoms. Frank in 1877 divided Encephalitis into various types, including a lethargic form which he stated occurred frequently as a result of epidemics of influenza.

Whether or not the observed combinations of symptoms have ever occurred before, the question early arose whether the syndrome should be regarded as a clinical entity or as a special manifestation of some disease previously known in other forms. The three diseases, with which its relations have been more particularly considered are botulism, influenza and acute poliomyelitis or Heine-Medin's disease. Botulism results from the consumption of infected meat or other food, usually ham, and is especially characterized by paralysis of the eye muscles. The disease is due to infection with a specific bacterium—the bacillus botulinus. Since the most careful search has invariably failed to detect the presence of this bacillus in Encephalitis Lethargica, botulism can be finally excluded. With regard to influenza, the appearance of Encephalitis Lethargica, including Noma as such, has approximately coincided with epidemics of influenza in 1889 and at the present time. On the other hand, there is considerable evidence against their identity. Influenza is highly contagious, while the clinical appearance of Encephalitis Lethargica occurs in an irregular manner and has not attained any great magnitude as an epidemic. When Encephalitis Lethargica commenced in Austria influenza had not yet appeared. There are also histological differences, since in influenzal encephalitis there is marked oedema of the brain and an absence of the two special characteristics of Encephalitis Lethargica—vascular congestion and infiltration of the perivascular lymph spaces. Pfeiffer's bacillus, the so-called influenza bacillus, is not found in Encephalitis Lethargica.

The relations of Encephalitis Lethargica to Heine-Medin's disease have led to much discussion. Unusual forms unquestionably occur in which the diagnosis is doubtful, both on clinical and pathological grounds, but, considering typical forms, there are striking differences between the two diseases. Heine-Medin's disease particularly attacks persons under 20 years of age, and tends to increase in frequency in summer. The onset of the general symptoms and of the paralysis is acute, the course is brief and the spinal cord is mainly affected. In Encephalitis Lethargica, on the other hand, persons of all ages are liable to attack, and the frequency is greatest in winter and spring. The onset is usually insidious, the course is lengthy, and the mid-brain is especially affected. Histologically there are also important differences. Microscopic haemorrhages are constant in Heine-Medin's disease, while perivascular infiltration is slight, the reverse being true of Encephalitis Lethargica.

Symptoms.—Encephalitis Lethargica was primarily recognized by the occurrence of the combination of lethargy and double vision, the latter being due to paralysis of the muscle of the eye. While pathological drowsiness in varying degrees is probably present in 70 to 80 per cent of cases at some stage of their course, further observation has revealed the occurrence of numerous other manifestations. The disease is widespread through the nervous system, and the complexity of the structure of the nervous tissues, together with the high degree of specialization of the functions of its various parts, explains the protean nature of its symptoms. Numerous types have been described, but the value of these is slight, as a single patient in the course of a few days often exhibits the characteristics of many such types. The clinical manifestations are probably best classified as Walsh suggested, according to the broad scheme proposed for other nervous diseases many years ago by Hughlings Jackson. In the following description based on this system, the positive symptoms denote exaltation of function, which may be due either to irritation of nervous tissue or to a loss of its control exercised normally by the higher centres of the brain, while "negative" symptoms denote depression or loss of function, principally due to destruction of nervous tissue.

A. General Symptoms Due to Toxic Infection.—These included weakness, headache, often occipital with some stiffness of the neck, shivering, vertigo, muscular pains and vomiting or other gastro-intestinal disturbances. The pulse may be rapid and eruptions, usually resembling measles, occasionally occur. The temperature is variable, and it has no characteristic course. It often rises after some days from 101° to 105° F. for a short period, but may be more prolonged, or pyrexia may be absent throughout.

B. Nervous Symptoms.—These are general and focal, the latter being due to affection of highly specialized portions of the brain.

(1) General Nervous Symptoms.—Positive symptoms are delirium, mania, restlessness and various degrees of excitement, while the more common negative manifestation is the characteristic lethargy, in all grades from simple apathy to complete coma. Innumerable degrees occur of these two extremes, or even combinations. The



patient may slowly drift into a somnolent state or may not uncommonly combine somnolence by day with insomnia or restlessness by night. Rarely an attack commences suddenly with the wildest delirium or mania.

(1) *Focal Nervous Symptoms.*—The positive symptoms include the following—

(1) Convulsions, which are occasionally generalized, resembling the epileptiform fit.

(2) Involuntary movements. These may develop during the attack or several months later in the course of convalescence. Numerous forms occur. The "myoclonic" type is characterized by short, rapid, rhythmic contractions of muscles, especially affecting the abdominal muscles and also the diaphragm, but the entire musculature or any group of muscles, or even a part of a single muscle may be affected. The contractions are 30 or 40 to the minute. Epidemic hiccough is possibly a variety of this type. Tremors, choreiform, atetoid and other movements of muscles may develop after the attack, some causing coarse spontaneous movements of large amplitude.

(3) Rigidity. This group includes the "Parkinsonian mask" and catalepsy, the latter being a condition of rigidity in which the limbs are retained for long periods in the position in which they are placed by an observer. The Parkinsonian mask, an expressionless facies, is common, and combined with rigidity produces the appearance of acute paralysis agitans, or Parkinson's disease.

(4) Muscular pains. These may be severe.

The negative symptoms are represented by paralyses. The commonest of these is the characteristic affection of the muscles of the eye, especially those innervated by the third pair of cranial nerves. The principal clinical symptoms are ptosis or drooping of the eyelids, double vision and paralysis of the muscles of accommodation. The pupils are often unequal and their reaction altered, the most common change being loss of reaction to accommodation while still reacting to light; but in rare instances the Argyle-Robertson reaction may be present. Optic neuritis is extremely rare, and never advanced. Less common are affections of the remaining cranial nerves, producing facial paralysis, difficulty in swallowing or in production of speech, etc. No portion of the nervous system is immune, and instances occur with paralysis of limbs and other parts, producing monoplegia, hemiplegia, diplegia, or aphasia. The sensory system is much less frequently affected. The deep reflexes are commonly but not invariably absent.

*Morbid Anatomy.*—The small vessels of the brain and meninges are dilated, the congestion often being visible both to the eye and under the microscope, but the most characteristic change is infiltration with small round cells of the perivascular lymph spaces, surrounding the capillaries. Other less constant and less conspicuous changes include degeneration of the nerve cells and destruction of neurons, proliferation of the mesoblastic cells lining the vessel walls and of the glial cells, and the occasional occurrence of hæmorrhages and of thrombosis of veins. The lesions are most common in the mid-brain and basal ganglia, but any portion of the nervous system or meninges may be affected.

*Prognosis.*—Excluding mild and abortive cases, and the so-called *formes frustes*, the mortality is about 33 per cent. Including all cases it is under 20%, but the exact figure is doubtful. Deaths usually occur within three weeks from onset. The duration may be many weeks or even months. Alteration of the mental functions may be prolonged, and paralyses, aphasia and other changes have persisted long enough in some instances to be regarded as permanent, but when recovery takes place, it usually becomes complete.

*Treatment.*—This is on the general lines of treatment of acute febrile disease. Hexamine is usually administered. Netter strongly advocates the production of a local abscess by the injection of turpentine, 1-2 cc., into the thigh, but the value of this is not yet confirmed. (H. L. T.)

**ENGINEERS, MILITARY** (see 946\*).—In the earlier article it was pointed out that in the early days of warfare, and in Great Britain up to the wars of Marlborough, the engineers of an army were the builders of fortifications, and also the manufacturers and directors of engines of war. In 1716 the first separation of specialists occurred when the Royal Artillery was definitely formed into a separate regiment. British engineer officers, left to their more specific duties of defensive works and of military surveys, were, until 1757, frequently holders of commissions in the infantry, and it was not until the siege of Gibraltar, towards the end of the 18th century, that any nucleus of enlisted rank and file was added to the corps of officers, who by that time were called Royal Engineers. This creation of specialist branches of military engineers naturally continued with the progress of engineering in civil life, and its application to military needs. Thus, after the experience of the American Civil War in 1861-5 had brought to light the extreme value of the electric telegraph in military operations, a telegraph troop was added to the Royal

Engineers in 1876. This unit, was shortly afterwards utilized by the British Post Office in connexion with civil telegraph duties, and for many years afterwards the connexion between the army and the civil department concerned was maintained in Great Britain to the great advantage of the military engineers, who by constant practice in the working of civil lines of telegraph were being prepared for this task in war. Gradually, however, the military specialties tended to develop, and the units concerned came to have a somewhat special equipment and to be divided into air-line companies (where the wires are carried on light poles rapidly erected), cable companies (where insulated cable is laid in any ground in any convenient way), and wireless.

Prior to the outbreak of the World War the signal service in the British regular army consisted of one signal squadron, 5 signal troops (for one cavalry division and 5 cavalry brigades), 6 divisional signal companies, and 4 other units. Some 1000 units were formed on mobilisation, the total establishment for the Expeditionary Force being 78 officers and 2,567 other ranks. In the Territorial Force there were 5 army troops and 14 divisional signal companies, the former units being subdivided into wireless, air-line and cable companies. In 1918 the total numbers had increased to 2,499 officers and 69,264 other ranks, exclusive of Dominion forces and those on the Indian establishment. The number of units was upwards of 400, operating at home and practically all the theatres of war, and including despatch riders, messenger dog service, carrier pigeons, wireless motor sections, and subsections attached to field and garrison artillery. The materials were partly obtained from the G.P.O. in England, but also from sources under the direct control of the director of fortifications and works who had under him five factories for the manufacture of special wireless sets, telephones and cables. The scale of supply may be inferred from one item alone, viz. insulated cable, of which enough was sent to France in one year of the war to go 10 times round the globe. Such an immense development as this, however successfully it was carried out (and there is no doubt on this point), evidently demanded an organization of its own, and consequently, after the war, a new branch was formed called "The Royal Corps of Signals."

In like manner the British Air Service, in 1912, was separated from the Royal Engineers. The first steps to form an aerial observation corps were taken about 1870, although individual officers had taken up the subject at a much earlier period. Aerial observations and photography from balloons were carried out on active service in the Sudan and Bochnanaland in 1887 and throughout the South African War 1899-1902. The development of the internal combustion engine, however, in the early part of the present century, made the dirigible-balloon possible, and the application of this engine to heavier-than-air machines in 1907 introduced into war a new factor of the utmost importance. The Air Battalion of the R.E., which in 1902 was mainly occupied with balloons, kites and kiteships, and had made some progress in developing the new inventions, became early in the following year the military wing of the Royal Flying Corps.

To some extent the work of submarine mining, brought to great perfection by the R.E. in connexion with coast defence in the closest co-operation with garrison artillery and defence electric lights, belongs also to this category. It was abolished, in so far as its connexion with the army is concerned, in 1905, its work being handed over to the Royal Navy. In this transfer, however, the co-operation between guns, lights and mines could not be carried out as before, and the reason for the change is not that of the two other instances, viz. the great growth and importance of the branch of engineering concerned.

While, however, the growth of special branches necessitated their severance from the parent corps, the exigencies of war brought into being other branches of a nature previously unforeseen. Besides signal units, the normal composition of the R.E. before the World War included field, fortress and railway companies, with field squadrons for the cavalry, and bridge and train with armies. Although these still continued, with numbers consequently increased, other special branches soon began to be formed. Army troops companies (formed out of the Service

\* These figures indicate the volume and page number of the previous article.

companies), were needed to carry out work behind the field companies in the front line, electrical and mechanical companies to deal with machinery of all sorts, army workshops companies, base park and advanced park companies to feed the insatiable demands of the fighting line for prepared trench materials and other such requirements. For mining warfare, tunnelling companies, officered by mining engineers, were enlisted and did magnificent service. For water supply, boring sections were needed, and in Egypt water-supply companies; for surveying, field survey battalions and companies, and for sound-ranging and observation (in conjunction with artillery) special sections and groups were formed. The foundation of some parts of the line and the land drainages of others demanded special sections, mostly enlisted in the English Fens. Field and anti-aircraft searchlights absorbed a large number of sections. Timber supply became a matter of urgent importance in the second year of the war, and forestry companies had to be formed to fell and prepare the quantities of timber needed for field engineering. The science of camouflage called for special units to deal with the provision and erection of concealing material. Chemical warfare demanded specialists both in preparing and projecting the new element of war. Meteorology played a new and important part, and it too required special units to take and record observations. The army post-office work devolved on the Royal Engineers. All these were altogether apart from the signal units, already touched upon. There was, further, the transportation branch, which formed a large and important feature in the area behind the line, and was divided into two main organizations (subsequently combined under one director-general), viz. Roads and Railways, and Inland Water Transport.

The former had railway construction companies, survey and reconnaissance section, a railway signal and interlocking company, wagon erecting companies, broad gauge workshop companies, and miscellaneous trades companies with electrical sections; light railways operating companies, train crew companies and forest companies, also miscellaneous trades companies, workshop companies, and light tractor repair companies. There were also training schools, chiefly for light railway work. There were numerous traffic sections, and broad gauge operating companies; there was a transportation stores company, and a steam boiler repair company. In connection with roads there were several road construction companies, and quarry companies with a quarry maintenance section, most of these enlisted in the Welsh quarries.

The Inland Water Transport had headquarters' units at various places in England—Richborough, where a magnificent new port was built, Southampton and Poplar. There were workshops and shipyard companies, and construction companies at Richborough and several other places in England, and port construction companies at many ports in France. There were marine companies, traffic companies and train ferry companies in England, while in France there were sections working all over the canals on the army areas, with headquarters at Aire.

In Egypt there were sections at Alexandria, on the Suez Canal, and at various places on the Nile; in Iraq at Basra; in E. Africa at Dar-es-Salaam and some other ports; in Russia at Murmansk. But perhaps the greatest work done by this branch, except in France, was in Mesopotamia, where the organization at Basra included vessels, marine engineering, accounts, dockyards and shipbuilding, native craft, I.W.T. Stores, buoyage and pilotage, conservancy and reclamation, camps, coal-depot, barge depot and construction H.Q. both on the Tigris and Euphrates. There were detachments at various places on each of the great rivers, and on the Persian lines of communication at Karén and Alwas, and also at Muscat.

At the outbreak of war the corps of R.E. consisted of 1,831 officers and 24,172 other ranks. On Nov. 11 1918 there were 17,711 officers and 322,739 other ranks. The above figures include regulars, special reserve, territorials, and all signal and transportation units, but not from overseas or India.

As regards troops from overseas it is perhaps sufficient to say that their strength was in proportion normally to the total numbers of all arms, but that in addition there were tunnelling companies from the Australian and Canadian mines (who did good service in France and in Palestine), and forestry battalions from the backwoods of Canada, who did most useful work in France, and also in Cyprus for the supply of timber to the armies operating in the eastern Mediterranean littoral.

Mention may here be interposed of two cognate organisations, one of which never was actually incorporated in the R.E.; the other

was part of the R.E. at one time, but was allowed gradually to disappear, or be merged in corps raised for work other than R.E. The former were the pioneer infantry battalions, to be supplementary to R.E. labour, on the principle well known in India, where such battalions, officered by infantry officers, and trained to a greater extent in field engineering than the average line battalions, had proved most useful. There was one such battalion per division, and the intention was that they should normally be associated, much more closely than other infantry, with the field companies Royal Engineers. The labour battalions, 11 of which were raised, were all of the professional navy class, all over military age, and officered by civil engineers, architects, surveyors, etc. They did excellent work and of a nature which was by no means unskilled. Whether the later policy of absorbing the personnel into labour companies, who did absolutely unskilled work (unloading ships, etc.), was wise, cannot be here discussed, but it had the effect of removing from the engineers' control a very valuable body of men.

One other Indian innovation was also introduced, viz., the appointment to corps and armies of field engineers and assistant field engineers, i.e. officers of civil-engineering experience (either R.E. or civilian) whose business it was to execute works, in the area of their corps or armies, by means of civil labour.

*Organization at Headquarters and in the Field.*—At the War Office the organization for developing and controlling not only the personnel, briefly indicated above, but also the design and execution of works and the design and provision for engineering equipment and plant, was divided among three of the principal branches of the Department, viz., one section under the adjutant-general had to raise and maintain all the above units; under the quartermaster-general the director of movements had to organize and control the transportation branches (railways and I.W.T.), while the director of fortifications and works and the branch of the master-general of the ordnance were responsible for all the technical design and execution of engineering works at home, and for supplying the varied and complicated machinery and plant for the engineering needs of the armies in the various theatres of war. This involved also the carrying-out of a series of experiments on all sorts of inventions, though after the war had progressed for some time this duty was partly taken over by the Ministry of Munitions, which in other respects did not supply military engineering needs.

The works directorate was divided into 12 branches, each under a senior officer of engineers:—(1) Rifle ranges, artillery practice grounds and lands generally; (2) huttet camps and barracks; (3) coast fortifications (on the E. coast of Great Britain especially); (4) ordnance store buildings; (5) aviation buildings, until Jan. 1918, when the Air Ministry was formed; (6) design branch, for evolving and coordinating all designs; (7) personal matters arising out of the employment of civilian engineers, electricians, foremen, surveyors, etc., on military works, in themselves a large host; (8) mechanical engineering and supply of stores connected therewith to armies; (9) electrical stores and experiments, which included the inspection branch, also telephone factories, and a wireless experimental station; (10) liaison branch with all armies in field, dealing with all miscellaneous needs; (11) experimental and equipment section; (12) contracts, schedules of prices, and quantity surveying.

Temporary training schools for dismounted and mounted men, as usual, but at Longmoor for railway men, at Hitchin and Bedford for signallers, at Newark, Deganwy (N. Wales), Irvine (Ayrshire), Buxton, and Brightlingsea (Essex) for training sappers. The wireless experimental section at Woolwich and the electric light school at Portsmouth also were valuable training depots.

As regards the organization in the field there was at first neither an engineer-in-chief nor a chief engineer for each army. There were senior engineer officers, one at G.H.Q. and one at the H.Q. of each corps, but their duties were advisory only, and they had no power of purchase, or of engaging civil labour. This organization was a deplorable legacy from the S. African War, when the nature of the campaign was so different from that in Europe.

On the lines of communication, on the other hand, there was a director of works, with a proper staff and adequate powers, but he had no part in any military operations, nor, judging from the *Field Service Regulations*, was it contemplated that, except in the rare possibility of a siege, there would be anything in the nature of engineering in war that could not easily be done by the field companies under their divisional generals. These numbered two per division under a lieutenant-colonel. In 1911 a committee under Lord Kitchener had recommended raising the number to three. But in 1914 this had not been carried into effect, many officers of experience considering that such increase, though possibly desirable, was not a matter of urgency. The first few weeks of the war altered all this. A new organization became imperatively necessary, and the increase of personnel was nowhere more marked than at G.H.Q.;

whereas in 1914 the entire staff of engineer officers at G.H.O. was one brigadier-general, in 1918 this staff was one major-general, two brigadiers and 19 other officers. Similarly the engineer staff of each army was increased from one to 11 officers—one for water supply, another for bridging, others for mining, camouflage, stores and so on.

The field companies, whose losses in the first few weeks of the war were very great, were increased at once from two to three per division, and a pioneer battalion in addition gave each divisional general a sufficient supply of both skilled and unskilled labour for him to make tactical use of engineering works. It was not intended that these troops should be used as infantry except in the gravest emergency, although in some cases this was not borne in mind, and the casualties which resulted made the want of such technical troops more acutely felt than ever.

Under the direct orders of the chief engineer of an army corps there were two or three army troops companies R.E., two or three tunnelling companies, a company or two of a labour battalion, and miscellaneous working parties and transport lorries.

**Field Companies.**—As the field companies were the most numerous of all the R.E. units (there were some 160 of them in France in 1918) as well as being the normal organization of military engineers—corresponding to a battalion of infantry, a squadron of cavalry and a field battery of artillery—it may be as well here to say a little about their organization. The field companies of the regular army (of which there were 13 in 1914) were formed about 1879 by adding to a few selected fortress companies a section of mounted drivers with transport to carry ordinary entrenching tools, and the special tools needed for the various tradesmen of which the company was composed. At that time the companies were almost exclusively employed on barrack maintenance, and, while subject to military discipline and trained as infantry in drill and musketry, they were given little or no special training as field engineers. But from the experience of the Egyptian and Sudanese campaigns of 1882-83 there began a steady improvement in their rôle as a valuable tactical arm. About 1885 each company was taken off the works annually for a course of field work instruction. In 1889 continuous engineer's pay, instead of working pay for actual hours spent on works, was introduced, a matter of the utmost importance, for it enabled men to be taken for military training without penalizing them in respect of pay, while their trade skill could still be economically utilized on works when they were not otherwise employed. The gradual improvement in the military training of this arm, and its cooperation with other arms, was, after the S. African War, still further developed by having the companies posted to army divisions under the direct responsibility of division headquarters, and by the participation by all ranks in the divisional training schemes. Further, young civil engineers were, by arrangement with the Institution of Civil Engineers, given commissions in the R.E. Special Reserve, and after some preliminary training were attached to field companies.

Each company consisted of six officers, all mounted, with about 220 other ranks, of whom about 75% (dismounted) were tradesmen, the remainder being drivers. There were some 60 horses and mules, with the following vehicles—four double wagons for tools and equipment, three ponies and a treadle tractor for bridging plants, and a special vehicle for explosives, sandbags, cordage, etc.—with the general transport vehicles appropriate to a unit of this size and composition. The company was organized in four sections, each under a subaltern, so that each section could be detached, with its own tools, for some specific task. There were also some pack animals to take tools, etc., to places where wheeled vehicles could not go. A certain number of the dismounted men were cyclists whose business it was to reconnoitre ahead and bring in information.

Although the greater part of the sappers (dismounted men) were skilled tradesmen, there was introduced, shortly before the outbreak of war, a certain dilution of skilled labour in the form of "pioneers," men who were trained in ordinary field work, but had not been taught a trade before entering the army. Whether this dilution was on the whole satisfactory is a matter on which there is difference of opinion. There is, however, no doubt that as regards the officers, the greater their knowledge and experience of engineering work the better, owing to the variety of the work that falls on a field company in war. Moreover, the development of weapons and the weight of guns, tanks, etc., which came to be used in the war revolutionized much of the previous practice. No longer were combinations of timber, brushwood and earth sufficient for field defences, nor pontoons and spar bridges sufficient to cross rivers. Concrete and steel had come into the field, and the engineers accustomed to use these in peace had to take them in hand for war, and to see that rapidity of construction was combined with stability and strength.

Broadly speaking, the duties of the field companies were field defences, mining, demolitions, water supply and distribution, and temporary roads and bridges, in the fighting zone. Behind these came the army troops companies R.E. and the many special units, whose duties are indicated by their nomenclature.

**The School of Military Engineering.**—It is evident that to train officers and men—the former especially—for the varied tasks that lie before them in war, some very special instruction is needed in peace. This is supplied by the School of Military Engineering at Chatham, to which every R.E. officer after receiving his first commission is sent for a course of instruction, lasting normally two years.

This school owes its origin to the Peninsular War. In that campaign at first there were no trained sappers and the operations of the R.E. were wretchedly ignorant of such military subjects as the demolition of bridges. As a result of Lord Wellington's representations and the advocacy of an able engineer-officer, Col. Pasley, a school of instruction in siege works was begun in 1812 at Brompton barracks, Chatham. In course of time instruction in other branches, as construction, surveying, electrical and mechanical engineering, chemistry, astronomy, etc., was added; and in spite of certain disadvantages, e.g. the growth of houses and establishments round the school, and the absence of troops of other arms with whom combined training could be carried out, the work done at this school has been of the utmost value both in war and in peace. Few officers and men trained there have gone to all parts of the Empire and made their mark in works of public utility and permanent value.

The training in the pre-war period was as follows:—The two years' course is approximately divided into four equal parts under each of the chief instructors, in field fortification, construction, surveying and electricity. The officers are attached to depot companies in one or other of the battalions of R.E. under training, and thus, concurrently with their technical training, they learn the routine of military administration, discipline and drill. As regards the four main courses of instruction, it is evident that in the short time available only the rudiments of each subject can be taught. In a profession which admits of so many different avenues of service to the country it is evident that the preliminary course of instruction should include that which is likely to be of value in each and every capacity. There must be a difficulty in arranging such a course when it is borne in mind that one officer may devote his life to purely military studies, another to the scientific work of, say, the Survey of India, another to railway construction, another to electric developments and so on. Yet there is doubtless some common ground in which all must be trained before diverging, and this is the object of the Chatham training. In field fortification, besides the principles of defence, already learned by the officers in the cadet stage of their career, there is the practice of entrenchments, redoubts, military mining and demolition; there is, further, construction of light railways and of field shelters, water supply expedients, and other miscellaneous subjects. This course is largely out of doors, and is especially valuable in teaching young men how to organize and handle skilled and unskilled labour. The survey course includes instruction in all surveying instruments and in the practice both of large survey operations and of the rapid operations frequently necessary in military exploration, and in combining the work of several observers in an unknown country. In the construction course lectures are given on building materials and builders' trades, on applied mechanics and hydraulics, on water supply, sanitary engineering, roads and railways, the design of structures, including bridges, reservoir walls, etc., and the ordinary methods of execution. Visits to engineering works in progress are included in the course.

Theory and practice are combined in this as well as in the mechanical and electrical engineering courses, the details of which are on similar lines. Care is taken to keep in close touch with the best civil-engineering practice in the country; eminent civil engineers are invited every winter to deliver lectures, and after the completion of the course selected officers are sent to work for six or eight months on one of the great railway lines, either to learn traffic control, or to be more thoroughly equipped in mechanical engineering in the railway workshops. Other officers go to the electric light school at Portsmouth for special training. (C. K. S.-M.)

**United States.**—The army which in its circumstances bears the closest resemblance to the English is that of the United States. Both countries recruit their armies by voluntary enlistment, and both use to some extent their military engineers, after completion of their training at a military school, in some form of civil-engineering service in peace.

From 1901 to 1916, the maximum authorized strength of the Corps of Engineers was 248 officers of all ranks, and 1,965 enlisted men forming 3 battalions of 4 companies each. The officers not needed for service with the troop units were employed on civil public works, inasmuch as the Corps of Engineers is charged with the improvement of harbours and rivers, both coastal and inland. As in the case of English officers in the civil-engineering departments in India and the colonies, this employment proved to be of great value in war in that it had trained them "to take heavy responsibilities; in the habit of making weighty decisions; meeting sudden emergencies; in the organization, operation and care of large bodies of men; and working with men not familiar with or subject to [army] discipline."

In the United States, officers for the Corps of Engineers are obtained from two principal sources, namely, the U.S. Military Academy at West Point, and the leading civilian engineering colleges. The Military Academy is not an engineering school, and, although the course furnishes a good foundation for a

engineering education, its graduates appointed to the Corps of Engineers nevertheless require additional instruction in engineering subjects. To that end they are detailed as special students for about a year at the more advanced civilian engineering schools.

Graduate engineers appointed from civil life need military instruction and are sent to the Engineer School of the U.S. Army immediately upon being commissioned. Subalterns of both classes, after completing their basic military education, are assigned alternately to duty with troops and on civil construction, where their training is continued for several years in accordance with a scheme formulated by the chief of engineers. This whole procedure, which is possible more formal than that prevailing in the British service, has the same end in view, namely, to give the officer a "well-rounded mental and professional development" which fits him for any service that war may entail. Selected officers of more mature age pursue advanced courses at the Engineer School and become eligible for the School of the Line, the General Staff School, and the Army War College, where they are instructed in the combined use of all arms of the service and the various duties of the general staff and the high command.

Under legislation effective June 2, 1916, the Regular Army of the United States was reorganized and expanded. Provision was also made for a reserve to be composed of (a) local forces in each state, and (b) a reserve corps of officers and of enlisted men. The former were the state National Guards, but in an emergency were subject to service under the Federal Government. The Reserve Corps was answerable directly to the Federal Government. Under this Act the Corps of Engineers of the regular establishment was to consist of 300 officers of all ranks, and one band; 7 regiments (foot), and 2 battalions (mounted) of enlisted men. The increase was to be made by five successive increments, so that on April 6, 1917, when the United States declared the existence of a state of war, the Corps of Engineers numbered only 256 officers and 2,228 enlisted men, the latter being organized in 2 regiments and one mounted company. There were, in addition, a few engineer troops organized as components of the National Guard.

During the World War, Congress passed a series of Acts affecting the military establishment and created a fourth element called the National Army, which name was applied to the organizations raised especially for the emergency, partly by voluntary enlistment and partly by the selective service law. In Aug. 1918, the distinctive appellations were discontinued and the 4 elements, viz.: the Regular Army, the National Guard, the Reserve Corps and the National Army, were merged and the single term "The United States Army" was applied to the entire military force.

At the time of the Armistice, Nov. 11, 1918, the standard combat regiment with its train had a strength of 40 officers and 1,600 enlisted men. At that time the engineer establishment consisted of 7 regiments (foot), 2 battalions (mounted), and 8 engineer trains derived from the regular establishment; 17 regiments with trains derived from the National Guard, and 31 regiments derived from the National Army, a total of 55 regiments, all assigned to divisions. There were also 6 regiments assigned directly, one to each corps headquarters. These 61 regiments were all of the pioneer company type; but there were also special engineer troops allocated to various headquarters, both at the front and on the lines of communication, for the construction, maintenance and operation of railways; for the assemblage and maintenance of railway equipment; for the construction, operation and maintenance of light railways; for the construction and maintenance of highways; for the construction of barracks, quarters, storehouses, wharves and other miscellaneous structures; for the production of lumber and timber products; for camouflage; for flash- and sound-ranging; for water supply, mining, quarrying, electrical and mechanical installations and operations; for surveying, printing, and the reproduction of maps and charts; for the operation of port facilities; for the operation of searchlights; for motor transport, chemical warfare, and "general service."

The "general service" force was composed of whites and corresponded to the British labour battalions. There were in addition certain labour units, called Pioneer Infantry, composed of negroes officered by whites. The special engineer troops were variously organized into regiments, independent battalions or independent companies, the strength of which was that of corresponding units of the standard Pioneer-Sapper regiments. The labour battalions usually consisted of 1,000 men with a proper complement of officers. Though originally organized under the Engineer establishment, the Motor Transport Corps, the Chemical Warfare Service and the Armoured Tank Corps later became separate organizations. The Railway Transport Corps was established as a separate service in France, but in America this branch remained under the general supervision of the chief of engineers.

During the war 13,527 commissions were issued to officers of engineers, and on Nov. 11, 1918 there were 10,886 officers holding such commissions. The approximate total enlisted strength of engineer units was 285,000, of whom 233,000 were overseas, and 52,000 were in the United States and its insular possessions. Comparing this with the British strength it must be remembered that,

on the one hand, in the American army the signal service is entirely distinct from the engineers; on the other hand, a certain amount of mechanical transportation is included, and the Americans made early provision for a large number of navvies for general engineering operations. The strength of the latter are included in the figures given for the American engineering service. The Quartermaster Corps of the American army, which constitutes its general supply service, had also a large number of labour units, generally composed of negroes with white officers.

The training of officers and enlisted men at temporary instruction camps was simplified by the fact that the officers were, in general, drawn from the engineering professions, and the enlisted men were drawn from various classes of artisans. The compulsory selective service law facilitated the assignment of each individual to that place in the military establishment for which he was best fitted by his peace-time occupation. The training in the instruction camps was therefore largely military, qualifying the personnel to apply to their military tasks the knowledge they had acquired as civilians in their peace-time vocations. As in England, the voluntary enlistment principle permitted a number of well-qualified engineers and technicians to join, early in the war, the infantry, artillery, and other combat units where their special training did not come into play. Their services would have been of far more value in the engineering or other specialist units.

(G. A. Y.)  
*Lessons from the War.*—It is possible to sum up a few of the lessons which the experience of the World War has taught.

There must be on the one hand the closest connexion and cooperation between the general staff and the engineers. The intentions of the commander must dominate the situation, and the engineering work must be coordinated so as to further such intentions, assist, and develop them as far as possible. There must therefore be, on the part of the general staff, such early information on the subject to the chief engineer that he may not only work out his technical plans, but may consider whether the possibilities of engineering science may not be used to forward the end in view to an extent hitherto unsuspected by the general staff.

There must be constant cooperation with other arms, especially infantry, and this must form part of the training in peace.

There must also be close touch with the great civil engineering institutions of the country. Apart from their great knowledge and experience of the developments of the profession of engineering they are in touch, in a way that can hardly be expected from military engineers, with the very latest developments of technical science, and with the ablest practical exponents of it on a large scale.

There must be the recognition that field defences, as such, are not the monopoly of the engineers. It is the business of the general in command, through his general staff, to decide when and where such defences should be constructed, and the senior officer of engineers should have a voice in the matter, but only in respect of technical matters involved. The training and duties of modern infantry enable that arm to carry out much of the required defensive work entirely without any engineer supervision or assistance, and they should be held responsible for such work. There is sure to be some work which is beyond the scope of infantry training, such as reinforced concrete, or the construction of "dug-outs," and this is chiefly the business of the engineers, but in ordinary entrenchments, wire, and other obstacles, revetments, and light bridging, infantry must be trusted to do their own work.

The supply of engineering plant and stores must be under the engineers, and other arms should draw on them as required.

There should be both at the War Office and in the field a branch of the Intelligence Department dealing specially with engineering information. While there must be cooperation between the general staff, other arms and agencies in the fighting line, there must be the closest cooperation between the engineers there and the higher engineering authorities immediately in rear, i.e. the corps and army chief engineers, whose business it is to coordinate all technical operations.

In a regular execution of work, whether by engineers or infantry, there must be (1) a carefully prepared scheme to ensure that each unit receives in good time clear instructions as to the nature and scope of work devolving on it; (2) rendezvous points must be carefully selected, notified to all concerned, and reliable guides must be provided to lead the working parties to the proper place by the best routes; (3) a proper scheme for issue of tools and plant, with definite responsibility for the return of tools in due course.

As regards the tactical employment of engineers the following points are worthy of notice:

In the preliminary battle it may be advisable to attach either an entire field company, or a large portion of one, to the troops making the attack, just as some engineers are always told off to accompany an advanced guard on the march, in order to clear away obstacles and to ensure that, while progress is not arrested, important tactical points are not overlooked. But, inasmuch as, once an engineer unit begins a work, it should not hand it over to another unit while under construction, it is best that as further engineer assistance is required, it should be done by engineer units being pushed forward "leapfrog" fashion, from reserves. Close watching of the tactical situation by the commanding engineer is vital, especially in the deliberate attack, as in trench warfare, there are the three

phases—preparation, assault, and following up. In the preparation the works are so numerous that the utmost care must be taken by the commanding engineer and the general staff that the engineer resources are devoted to the most important objects. Then in the assault, the engineers should never be sent with attacking infantry except with specific instructions for definite work for which they can prepare beforehand, e.g. the consolidation of tactical points or opening up a forward communication. Even then they should not follow the leading waves of attack too closely, as they get mixed up with the fighting line, and do not accomplish their actual work. The engineer-commander should retain within his immediate control as much of the personnel as possible for the all-important work of rapidly opening up forward communication during the attack, and also for the disposition of the engineers in the phase following up a successful attack, when the work is similar to that of the encounter battle, viz. securing the fresh objectives gained.

As regards defence there are (1) advanced works in close contact with the enemy—the "outpost zone"; (2) the main position of resistance; (3) one or more rear systems. The first of these will ordinarily be carried out by infantry, with possibly some engineer assistance. The main position will be developed by the divisional engineers, with such additional labour from other arms as may be possible to allot. Rear defensive positions will be undertaken, usually, under the orders of corps and army commanders.

In position warfare the engineer duties also include preparation for attack, arrangements for the comfort, security, and efficiency of the troops behind the line, development of communications, and duties in connexion with raids. It is essential that all the engineer units should be under the control of the commanding engineer, and that he should maintain a programme of the necessary works to be carried out, and obtain the orders of the divisional general as to the order of urgency. It must, however, be always borne in mind in this as well as in other defensive work that the responsibility for construction and maintenance of works on any sector of the system rests with the commander of the troops in that sector.

In the case of a forced retreat in the presence of a pursuing enemy the work of the engineers will be mainly the delay of the pursuit by demolitions, and the erection of obstacles, but will include also the preparation of successive defensive positions, and the construction of special communications to allow the withdrawal of troops and guns. The work requires careful coordination and control under great difficulties. As the movements of the engineer-units depend on the localities where the works are required, they will not usually correspond with the movements of infantry in touch with the enemy. The officers of engineers must keep in close touch with the situation, act with initiative and readily assume responsibility, keep their superior engineer-commanders informed of the situation and progress of work, and be ready to respond to any call for assistance, provided they are satisfied that such a call is warranted and is relatively more important than other orders.

Efficient liaison is of the utmost importance.

In all operations of war it is imperative that the engineers should have:—(1) A close and accurate knowledge of all developments of the tactical situation; (2) a thorough comprehension of the needs of the other areas; (3) definite schemes and estimates of men, time and materials, sufficiently accurate for practical purposes; (4) well-prepared arrangements for materials and for passing information to other divisions or corps adjutant or in rear. Having developed these, an engineer-commander should be able to furnish the general staff with sound and competent advice on the engineering aspect of the operations, and should be able to utilize to the best advantage the available resources. (G. K. S.-M.)

**ENGLISH FINANCE** (see p. 458).—In the period from 1902 to 1921 English national finance underwent changes of a very far-reaching character.

**Pre-War Period.**—When Mr. Asquith succeeded to the Chancellorship of the Exchequer under Sir H. Campbell-Bannerman's administration in 1905 he found that public expenditure had increased rapidly in the previous decade. In 1895-6 the total was £97,700,000; in 1905-6 it had risen to £150,400,000. Mr. Asquith was responsible for the Budgets for the three years ended 1908-9. His policy was one of consolidation and retrenchment, which was necessary in view of the costly character of the S. African War and the gradual rise of expenditure generally. On the whole his record at the Treasury during his period of office was good. He managed to check the growth of expenditure, but his work was chiefly distinguished by successful efforts to reduce the National Debt. In the three years ended 1908-9, he reduced the dead-weight debt by £43,300,000 to £711,400,000.

The social reform programme initiated by Mr. Asquith in the Old Age Pension scheme was greatly developed by Mr. Lloyd George when he took over the reins of finance, and its effects were so stupendous that it affected in profound degree the national finances for the ensuing decade. Mr. Lloyd George's first

measure of expenditure was the National Insurance Act of 1911. In 1911-2 the total expenditure rose to £178,545,000, and in 1912-3 to £188,622,000 of £90,922,000 more than in 1908-9, when Mr. Lloyd George assumed office. The great increase in the Post Office estimates at this period was due to the acquisition of the National Telephone Company's undertaking.

The policy of the Liberal administration, which at first was economy, was turned by the pressure of political events into a policy of growing expenditure and taxation. In the period from 1909-10 to 1913-4, the expenditure on the navy rose from £55,807,000 to £48,833,000, on the army from £17,236,000 to £28,346,000, while that of the Civil Service jumped up from £40,010,000 to £53,901,000. Original estimates of the cost of Old Age Pensions were hopelessly wrong, and the total in 1913-4 had risen to £11,600,000 or double the cost as estimated in 1908. About £3,900,000 of the increase was due to the amendment of the law in 1911. Part of the excessive outlays on pensions was attributed to absence of compulsory registration in the first half of the 19th century. A large number of people in the rural districts was able successfully to claim the right to the pension, not because the claim was correct, but because the pension officers was unable effectually to contest the claim.

The policy of social reform to which the Liberal administration was committed produced, in 1909, a Budget, which will rank as famous in English financial history on account of the constitutional changes which it produced, and because events showed that Mr. Lloyd George's programme of land taxation, based upon an alleged appreciation of Henry George's theories, proved to be unworkable and fallacious. The Finance bill of 1909-10 was read a third time in the House of Commons on Nov. 4 1909, and was rejected by the House of Lords on the 30th of the same month. The Budget statement anticipated a revenue of £162,500,000, or about £11,000,000 more than in the previous year. It actually produced £131,696,000, largely because on the Lord's rejection of the bill the collection of income tax and tea duty was suspended. After the general election in Jan. 1910 which kept the Government in office, the Finance bill of 1909-10 was reintroduced on April 20 1910, and the Lords passed it on April 24.

The principal features of this Act were that it made the estate and inheritance duties much heavier, that it raised income tax from 12 to 15 per cent. in the £, abolished the abatements granted to those resident out of the country and imposed a super-tax (an additional rate of income tax) of 6d. in the £ on incomes over £5,000, the first £3,000 being excluded from the assessment to this duty. But the big novelty of the Budget was the land value duties which were chiefly responsible for the conflict with the second chamber. Four duties were imposed: the increment value duty of 20% on the increase in the value of land sites payable on land changing hands, the undeveloped land duty of 3d. in the pound on capital value; the reversion duty of 10% on benefits accruing from the termination of a lease of land; and the mineral rights duty of 1s. in the £ on mineral royalties, way leaves, etc. Agricultural land was excluded from the land value duties. The bill naturally involved a valuation of all land in the United Kingdom.

In the end the land duties were found to be very difficult to collect, and the advanced political assumption that there was something wrong about profits derived from the appreciation of the value of land had some extraordinary consequences. It certainly led to the break-up of big estates, but it wholly failed to produce revenue. The land value duties were originally estimated to yield £600,000 in the first year and a great deal more in future years. But these forecasts were woefully wrong. In 1910-1 the yield was £20,000; in 1911-2 £481,000; in 1912-3 £455,000; in 1913-4 £315,000; in 1914-5 £412,000; in 1915-6 £363,000; in 1916-7 £21,000; in 1917-8 £685,000; in 1918-9 £664,000; in 1919-20 £663,000; and in 1920-1 £200,000. Their abandonment in 1920 was the inevitable result of their disappointing yield. Of course the yield of the duties depended a great deal upon the valuation of land establishing a datum line for the duties, and that could not be completed for many years. In 1920-1 it had not been finished. Meanwhile the larger proportion of the land value duties was derived from the mineral rights duty. The growth of mechanical transport, following the introduction of the internal combustion engine, led to the imposition of duties on motor vehicles, a part of the proceeds of which was allocated to a Road Development Fund, established in 1909. At the same time a development fund was set up for the purpose of promoting, by Government Departments, colleges, institutions, or persons not trading for profit, by means of loans or grants, agriculture, forestry, drainage, harbours, fisheries, transport by experimental work.



The National Debt, which had been reduced from £762,463,000 in 1909-10 to £707,654,000 in 1913-4, was destined to grow at an enormous rate during the European War. Figures showing the form of the debt are set out below:—

The average British National Expenditure in 1914-5 was £1,500,000 a day; it grew to £3,750,000 in 1915-6, to £6,587,000 in 1916-7, and to £6,986,000 in 1917-8. A rule was laid down by Mr. Reginald McKenna, who succeeded Mr. Lloyd George as

*British National Debt in million £.*

	Aug. 1 1914	March 31 1915	March 31 1916	March 31 1917	March 31 1918	March 31 1919	March 31 1920	March 31 1921
<b>Funded Debt</b>	588	544	318	318	318	318	315	315
Term Annuities	30	28	26	24	22	22	19	19
3½ % War Stock		349	63	63	63	63	63	63
4½ % War Stock			900	20	16	14	13	13
4 & 5 % War Stock				1,962	2,091	2,068	2,040	1,971
National War Bonds					649	1,636	1,476	1,441
4 % Funding Loan							409	407
4 % Victory Bonds							387	358
Treasury Bonds								22
Treasury Bills	15	77	567	464	961	957	1,107	1,121
Exchequer Bonds	20	67	177	320	392	384	319	292
Nat. Savings Certs.				75	139	227	274	283
War Expnd. Certs.					23			
Foreign Debt			9	317	944	1,241	1,181	1,136
Anglo-French Loan (British Portion)			31	51	51	51	51	51
Temporary Advances	1		20	218	204	455	205	155
	664	1,195	2,132	3,856	5,872	7,436	7,829	7,895

**War Period.**—The outbreak of war in Aug. 1914 was followed by a number of emergency regulations which were destined to have a profound effect upon the national finances during the war period. The Government decreed a general moratorium, and agreed to advance currency notes to bankers at Bank Rate to the extent of 20% of their deposits. At first the banks availed themselves of this facility to relieve the shortage of cash to the amount of £13,000,000, but by the end of Nov. 1914, when the moratorium expired, this amount had virtually been repaid. The banks found that Government expenditure provided them indirectly with all the currency they required, this of course being the inevitable effect of inflation. On Aug. 1 1914, the Government gave the Bank of England authority to suspend the Bank Act of 1844, but it was never acted upon, because the passage of the Currency and Bank Notes Act on Aug. 6 1914 rendered the suspension of the Bank Act unnecessary. The excess fiduciary issue was always turned into the currency note issue. The next step was the undertaking of the Government to discount at 2% above Bank Rate all pre-moratorium bills of exchange. The amount discounted was nearly £300,000,000, of which about £35,000,000 remained in cold storage until after the war.

The war was financed by means of Votes of Credit. There were 25 Votes of Credit, as set out below:—

*Votes of Credit in the War.*

1st—Aug. 6 1914	£100,000,000
2nd—Nov. 18 1914	225,000,000
3rd—March 1 1915	37,000,000
	(Financial year) £362,000,000
4th—March 1 1915	£250,000,000
5th—June 15 1915	250,000,000
6th—July 20 1915	130,000,000
7th—Sept. 15 1915	250,000,000
8th—Nov. 11 1915	400,000,000
9th—Feb. 21 1916	120,000,000
	(Financial year) £1,420,000,000
10th—Feb. 21 1916	£300,000,000
11th—May 23 1916	300,000,000
12th—July 24 1916	250,000,000
13th—Oct. 11 1916	300,000,000
14th—Dec. 14 1916	400,000,000
15th—Feb. 12 1917	200,000,000
16th—March 15 1917	60,000,000
	(Financial year) £2,010,000,000
17th—March 15 1917	£350,000,000
18th—May 9 1917	500,000,000
19th—July 24 1917	250,000,000
20th—Oct. 30 1917	200,000,000
21st—Dec. 12 1917	50,000,000
	(Financial year) £2,450,000,000
22nd—March 7 1918	£500,000,000
23rd—June 18 1918	500,000,000
24th—Aug. 1 1918	700,000,000
25th—Nov. 1918	700,000,000
	(Financial year) £2,900,000,000
<b>Total (1914-6)</b>	<b>£8,942,000,000</b>

Chancellor of the Exchequer in 1916, that the Budget should provide for all normal expenditure and the war debt charge. This standard of finance was high—higher than that aimed at by any other belligerent. Thus in the year 1915-6, expenditure amounted to £1,559,188,000, of which £336,737,000 was provided by revenue. Tax revenue amounted to £290,088,000 or 18.6% of the expenditure. In 1916-7, £573,428,000 was raised by revenue, or 26% of the total expenditure, tax revenue being £514,105,000, or 23.3 per cent. In 1917-8 tax revenue contributed 22.7% to the expenditure, the total revenue being 26.2 per cent. In 1918-9 tax revenue yielded 29.7 per cent.

Increased taxation was imposed in each War Budget. As far as possible the Government relied upon screwing up existing taxation, and avoided as far as possible the imposition of new taxes. The only new tax of any great importance was the Excess Profits Duty. This duty (*see* EXCESS PROFITS) was extraordinarily prolific and ranks as one of the most skillfully-devised fiscal measures of the war; it was largely imitated abroad. It sought to appropriate for national purposes a large slice of the exceptional profits secured by those engaged in business, and at the same time to provide a big new additional source of revenue. The duty was first imposed in 1915, and was applied for a period of seven years to all businesses. At first the rate was 50%; it was increased to 60% in April 1916, and from 60 to 80% in May 1917. No change was made in 1918, but in 1919 the rate was reduced to 40%; and raised again to 60% in 1920. In the budget of 1921 it was brought to an end.

**Income Tax** (*see* INCOME TAX) was doubled in the first War Budget introduced on Nov. 17 1914 by Mr. Lloyd George. It was raised from 1s. 3d. to 2s. 6d., and the rate for earned income was hoisted up from 9d. to 1s. 6d. in the pound. Super Tax was also doubled. In the third War Budget introduced in Sept. 1915 (the second was in May, 1915), 40% was added to income tax, the exemption limit was reduced from £160 to £130, and abatement limits from £60 and £20 to £120 and £100 respectively. The reduction made in Sept. 1915 in the limit of exemption to incomes below £130 increased the number of taxpayers by a very large figure, practically every working man being rendered liable to the tax. To meet the convenience of the working class-taxpayers' quarterly assessments were introduced. These classes insisted upon a differentiation between married men and bachelors. This was made in 1918-9 and subsequent Budgets, the differentiation taking the form of an abatement in income of £25 in respect of a wife living with her husband.

An "entertainments tax" was introduced in the Budget for 1916-7, the tax ranging from 1d. on a 2d. ticket to 1s. on a 12s. 6d. ticket, with an extra shilling for every 10s. over 12s. 6d. In the following year this tax, which proved successful, was increased by 50 per cent. Other new taxes imposed in 1916



included a Customs and Excise Duty on matches, which was increased two years later. In 1918 the stamp duty on cheques was increased from 1d. to 2d., despite considerable protest from bankers and others that it would produce very undesirable consequences. A still more important change affecting the customs of the people was the abolition of the 1d. postage on letters. In 1918 the minimum charge for letter carrying was raised to 1½d., and that for postcards to 1d. In 1920 the minimum postage for inland letters was raised to 2d. for a weight not exceeding 3 oz., an extra ½d. being charged for every additional ounce. For inland newspapers the charge for postage was fixed at 1d. for weights not exceeding 6 ounces. Inland parcel rates were raised to 9d. for weights up to 2 lb., and 1s. for weights between 2 and 5 pounds.

In the three financial years ended March 31 1918 indirect taxation actually diminished, the yield in the last of these years being smaller than in the first. In 1915-6 the produce was 177½ millions, in 1916-7 134½ millions, and in 1917-8 158½ millions. But direct taxation, which in 1915-6 yielded 131½ millions, gave 348½ millions in 1916-7, and no less than 473 millions in 1917-8. In the 1918 Budget indirect taxation was screwed up. The duty on spirits was raised from 14s. 9d. to 30s., while the beer duty was increased from 25s. to 50s. per standard barrel. Tobacco duty, which was raised by 1s. 10d. per lb. in 1917, was increased from 6s. 2d. to 8s. 2d. in 1918.

In 1916 there was much criticism of the Government's financial methods. Bank Rate was raised to 6%, and Treasury Bills were put "on tap" at 6% discount. Six per cent Exchequer Bonds were also put on sale. But the payment of these high rates for money (see MONEY MARKET) at a time of active inflation when money was abundant met with severe criticism. It was ostensibly designed to attract foreign money to London, but eventually it was decided to abandon the "dear money" policy and to offer a special rate, above the domestic rate, for foreign moneys. The year 1916 witnessed a new innovation in borrowing. What was described as the "continuous loan" principle was introduced in that year—namely, the daily offering of war securities instead of the flotation of fixed period subscription loans of the old-fashioned variety. At first this type of borrowing was not very successful, but with the introduction of modern publicity methods in 1917 the continuous loan plan became a very remarkable success.

The following are the aggregate figures for the British financing of the war from Aug. 1 1914 to Nov. 16 1918, five days after the Armistice was signed:—

Total expenditure	£8,656,198,215	Yield of revenue	£2,220,235,719
Balance	6,141,062	Net borrowings	6,442,103,556
Total	£8,662,339,277	Total	£8,662,339,277

In the tables below and on the next page are shown revenue and expenditure for the 12 years ended March 1920-1.

Revenue 1910-21 (000's omitted).

	1909-10	1910-1	1911-2	1912-3	1913-4	1914-5	1915-6	1916-7	1917-8	1918-9	1919-20	1920-1
Customs	30,348	33,140	33,649	33,485	35,450	38,662	39,606	30,561	71,261	102,780	149,360	134,000
Excise	31,032	40,020	38,380	39,590	38,000	42,313	61,270	56,380	38,772	39,440	338,663	199,780
Motor Vehicle Duties												7,073
Stamps, etc., Duties	21,766	25,452	25,292	25,248	27,359	28,382	31,036	31,232	31,674	30,262	40,904	47,239
Patent Stamps	8,079	9,784	9,454	10,059	9,966	7,577	6,764	7,878	8,300	12,438	22,586	26,991
Land Tax	150	1,220	750	700	700	630	660	640	665	630	680	680
House Duty	560	3,080	2,130	2,000	2,000	1,930	1,990	1,960	1,960	1,850	1,860	1,920
Property & Income Tax (inc. Super Tax)	13,295	61,946	44,804	44,806	47,249	69,399	128,390	205,033	239,509	291,186	359,099	394,446
Excess Profits Duty							140	1,399,920	220,214	285,028	290,045	219,181
Corp. Profits Tax												650
Land Value Duties		520	481	455	715	412	363	521	685	664	663	20
TOTAL	105,230	175,168	155,049	154,753	163,029	189,305	290,088	514,105	613,040	784,278	998,960	1,031,723
Postal Service	16,220	19,220	19,650	20,300	21,100	20,400	24,100	24,350	25,200	29,400	41,000	36,300
Telegraph Service	3,090	3,175	3,105	3,080	3,080	3,000	3,350	3,450	3,500	3,800	4,800	5,200
Telephone Service	1,720	1,965	2,045	2,175	2,300	2,500	2,650	2,800	2,900	3,200	3,800	4,200
Crown Lands (Net Receipts)	480	500	530	530	530	545	550	650	690	760	680	660
Receipts from Sundry Loans, etc.	1,260	1,234	1,281	1,479	1,580	1,277	2,432	8,056	6,056	11,679	14,052	30,171
Miscellaneous	1,688	2,000	2,330	2,025	2,004	5,917	9,797	16,447	52,148	52,303	280,829	313,325
TOTAL REVENUE	162,606	225,891	195,050	188,008	198,042	225,604	336,767	573,428	707,235	889,021	1,308,376	1,423,359

An important feature of English finance during the war period was the borrowing of money abroad, especially during the period of actual hostilities. The first loan was raised in the autumn of 1915, when the British and French Governments jointly and severally issued a loan for 500,000,000 dollars in New York. The position of Great Britain's foreign debt on March 31 1921 is shown below:—

Foreign Debt, 1921.

Debt to:—	In Currency.	In Pounds Sterling at Par of Exchange.
U.S.A. Government	\$4,196,818,000	1,862,362,000
Total to U.S.A.	4,733,214,000	972,704,000
Canadian Government	132,326,000	27,190,000
Total to Canada	257,326,000	53,339,000
Sweden	Kr. 12,500,000	826,000
Straits Settlements	—	7,656,000
Mauritius	Rs. 8,071,300	538,000
Allied Government	—	126,500,000

The total foreign debt, expressed in pounds sterling at the par of exchange, was, on March 31 1921, £1,161,563,000, a decrease of £117,151,000 on the total as on March 31 1920, and of £23,287,000 from the highest point reached on March 31 1919.

The figures of the deadweight debt, which included the foreign debt, were as follows in each of the financial years 1909-20:—

Year	£	Year	£
1909-10	713,245,000	1916-7	62,140,788,000
1910-1	682,232,000	1917-8	4,011,448,000
1911-2	674,744,000	1918-9	5,871,851,000
1912-3	661,474,000	1919-20	7,434,949,000
1913-4	651,270,000	1920-1	7,829,000,000
1914-5	1,108,817,000		7,573,000,000

The amount of advances and loans to the Allies on March 31 1921 was made up as follows:—

Russia	£ 561,400,000
France	557,000,000
Italy	476,800,000
Belgium (war)	94,000,000
Belgium (reconstruction)	9,600,000
Serbia	22,100,000
Portugal, Rumania, Greece and other Allies	66,200,000
TOTAL	1,786,900,000

Loans to the Dominions were made on the same date as follows:—

Australia	£ 90,000,000
New Zealand	29,600,000
Canada	13,800,000
S. Africa	7,500,000
Other Dominions	3,300,000
TOTAL	144,000,000

Further tables show income-tax rates, and the yield for total direct taxation, 1910-21.

### Income Tax Rates, 1910-21.

	1909-10 to 1913-4	1914-5*	1915-6†	1916-7 and 1917-8	1918-9 and 1919-20	1920-1
	1s. 2d. 9d. to 1s. 2d. 6d.	1s. 3d. 9d. to 1s. 3d. 5d.	2s. 6d. 10d. to 2s. 8d.	3s. 2s. 3d. to 3s. 10d.	6s. 2s. 3d. to 6s. 1s. to 4s. 6d. Chargeable on incomes over £2,500.	6s. (Standard Rate) 3s. (Half Rate) 1s. 6d. to 6s. Limit reduced to £2,000.

\* The rates for 1914-5 were doubled for the last four months of the Income Tax year.  
 † The rates for 1915-6 were increased by 40% for the second half of the year and Super Tax extended to 3s. 6d.

### Expenditure, 1910-21 (000's omitted).

	1909-10	1910-1	1911-2	1912-3	1913-4	1914-5	1915-6	1916-7	1917-8	1918-9	1919-20	1920-1
Total National Debt Services	21,728	24,864	24,500	24,500	24,500	22,669	60,249	127,250	189,853	269,965	332,034	349,399
Payments to Local Taxation Accounts, etc.	9,445	9,882	9,636	9,633	9,734	9,529	9,757	9,895	9,731	9,681	10,746	10,785
Other Consolidated Fund Services (Civil List, Annuities & Pensions, Salaries & Allowances, Courts of Justice, & Misc. Services)	1,654	1,664	1,693	1,692	1,693	1,693	2,788	1,974	1,670	1,699	1,948	1,796
Army	27,236	37,449	27,649	28,071	28,346	28,886	115	115	115	115	395,000	x x
Ministry of Munitions	—	—	—	—	—	—	—	—	—	—	—	x x
Navy	35,807	40,386	42,858	44,366	48,833	51,959	17	117	117	117	358,528	x x
Air Force	—	—	—	—	—	—	—	—	—	—	—	x x
<b>TOTAL CIVIL SERVICES</b>	<b>40,010</b>	<b>43,998</b>	<b>46,000</b>	<b>51,044</b>	<b>83,901</b>	<b>56,986</b>	<b>54,718</b>	<b>54,113</b>	<b>61,242</b>	<b>67,988</b>	<b>369,054</b>	<b>x x</b>
Customs and Excise	2,116	2,211	2,297	2,324	2,431	2,470	2,514	2,397	2,473	2,669	4,992	x x
Inland Revenue	1,226	1,708	1,654	1,876	2,052	2,123	2,089	2,331	2,683	2,970	4,430	x x
Post Office Services	18,693	19,681	20,547	23,024	24,007	26,060	26,673	26,454	25,738	26,396	46,064	x x
<b>TOTAL SUPPLY SERVICES</b>	<b>125,088</b>	<b>134,533</b>	<b>141,000</b>	<b>151,504</b>	<b>160,170</b>	<b>168,054</b>	<b>86,018</b>	<b>85,328</b>	<b>92,169</b>	<b>99,956</b>	<b>1,230,568</b>	<b>817,381</b>
Votes of Credit (Naval and Military Operations, etc.)	—	—	—	—	—	357,000	1,399,652	1,973,665	2,402,800	2,198,000	87,000	—
<b>TOTAL EXPENDITURE CHARGEABLE AGAINST REVENUE</b>	<b>157,045</b>	<b>171,999</b>	<b>178,548</b>	<b>188,622</b>	<b>197,493</b>	<b>260,471</b>	<b>1,554,582</b>	<b>1,982,108</b>	<b>2,222,696</b>	<b>2,212,579</b>	<b>3,011,665</b>	<b>773,195</b>

† Nominal amounts, the substantive issues being made under Votes of Credit.  
 ‡ Included under Civil Services (Unclassified), in 1919-20.  
 x x Figures not available. \* Excise transferred from Inland Revenue to Customs in 1909-10.

### Direct Taxation, 1910-21.

Years ended March 31.	Land Tax	Inhabited House Duty.	Property and Income Tax and Super Tax.					Super Tax.	Total.	Excess Profits Duty.
			Schedules.							
			A.	B.	C.	D.	E.			
1909-10	118,168	521,932	1,560,000	50,000	2,085,000	7,907,048	1,150,000	12,752,098	—	
1910-11	1,209,648	3,212,026	15,802,000	316,000	2,530,000	37,439,439	4,418,000	2,891,000	163,396,439	
1911-2	747,377	2,109,877	10,164,000	307,000	2,768,000	35,286,043	2,892,000	3,018,000	44,334,043	
1912-3	697,173	1,955,887	10,093,000	203,000	2,794,000	25,202,392	2,909,000	3,600,000	44,712,392	
1913-4	690,007	1,994,400	10,304,000	214,000	2,867,000	27,293,763	3,223,000	3,339,008	47,240,771	
1914-5	661,376	1,886,692	13,391,000	273,000	3,724,000	37,039,831	4,396,000	10,121,023	60,544,854	
1915-6	679,797	1,975,068	24,287,000	617,000	9,377,000	69,785,936	8,306,000	16,787,654	129,160,599	
1916-7	653,489	1,882,793	37,109,000	3,120,000	18,500,000	116,998,039	10,920,000	19,140,411	205,678,450	
1917-8	682,737	1,941,396	39,000,000	2,820,000	15,000,000	139,036,990	19,000,000	23,278,704	238,135,694	
1918-9	642,760	1,859,526	21,900,000	4,820,000	19,700,000	185,647,799	25,640,000	35,560,083	293,267,882	
1919-20	671,200	1,935,413	44,000,000	7,900,000	22,000,000	209,829,475	32,800,000	42,404,597	359,434,072	
1920-1	650,000	1,900,000	—	—	—	—	—	304,146,000	219,181,000	

NOTE.—The figures in the above table give the amount of the actual net receipts derived from the Revenue due to the Exchequer. The net receipt of Property and Income Tax, etc., represents the amount of tax actually collected within the year (irrespective of the year of assessment) less the amount of Tax refunded, etc., within the year. The amounts under the several schedules show the approximate net receipt of the Tax based on the assessments of property and income under each schedule.  
 † Including arrears of 1909-10.  
 ‡ Includes Munitions Levy.

**After the War.**—With the termination of the war, taxation in some directions was stiffened, and the revenue continued to expand until it reached the unprecedented figure of £1,425,985,000 in 1920-1. In the 1919 Budget death duties on estates over £2,000,000 were raised to 40% and the tax on the larger incomes was raised slightly, thus hastening the break-up of the historic country estates, which became a feature of the social changes in the post-war period. The tax on beer was raised from £2 15s. 6d. per 36 gal. to £3 10s., and that on spirits from £1 10s. to £2 10s. for proof gallons. It may be explained here that the highest pre-war rate of income tax was 1s. 3d. in the pound, in 1910-20 it was 6s. In 1914 an earned income of £600 paid £18 in income tax; in 1919-20 it paid £75, which shows that roughly the income

tax was multiplied by four. A feature of the 1919-20 Budget was the introduction of a form of Imperial Preference. In 1920 a Royal Commission which had been appointed to consider the question of income tax made certain recommendations of reform. Some of these were incorporated in the Finance Act of 1920, whereby a radical alteration was effected in the method of granting relief in favour of earned income, and of the method of graduating the burden of the tax. Exemption from tax was granted to single persons up to £135 (and up to £150 in the case of earned incomes) and to married persons (without children) to £25 (and up to £250 if wholly earned). In arriving at assessable income a person was allowed to deduct one-tenth of all earned income, up to a limit of £200. That is to say, a person with an

Liabilities and Credits (1901-1921).

Year ended March 31.	Gross Liabilities of State.	Assets Estimate.		Loans to Allies.	Loans to Dominions.	Loans for Relief to European Countries.
		Suez Canal Shares Market Value.	Other Assets.			
1910	£ 762,468	£38,295	£ 4,118	—	—	—
1911	783,072	37,608	4,003	—	—	—
1912	724,806	44,046	3,704	—	—	—
1913	716,288	39,015	3,707	—	—	—
1914	707,654	34,929	3,350	—	—	—
1915	1,165,802	29,993	3,243	14,170	39,533	—
1916	2,197,439	26,658	3,419	288,481	91,161	—
1917	4,063,645	27,404	3,216	827,835	146,778	—
1918	5,921,096	29,628	70,673	2,335,675	194,439	—
1919	7,481,060	32,818	54,216	1,870,264	170,890	—
1920	7,875,642	23,192	82,831	1,724,586	119,597	8,074
1921	7,619,000	—	—	1,786,000	144,000	16,700

\*Figures not available.

earned income of £2,000 was entitled to deduct £200, but if the earned income exceeded £2,900 not more than £200 was deductible. On the first £225 of taxable income arrived at after deducting the various allowances provided for—such as one-tenth in respect of earned income, wife and child allowances, insurance premium, dependent relief, etc.—tax was imposed at half the standard rate, namely 3s. in the pound and at 6s. on each pound in excess of £225. Thus the various rates of tax previously in use were abandoned and two rates of tax put in their place. Super-tax was stiffened and regraded.

The table above shows the aggregate gross liabilities of the State on March 31 in each of the years 1910-21, together with figures of assets, loans to countries allied to Great Britain during the war, and also to the Dominions, and advances for European relief granted after the termination of the hostilities.—

To sum up, the World War cost Great Britain over £10,000,000,000, while if allowances be made for the expenditure of the Dominions the total would be very much greater. An analysis of the expenditure of the United Kingdom from 1688 to 1920 disclosed the fact that in the six financial years from March 31 1914 to March 31 1920, Government expenditure exceeded the total expenditure for the 21 centuries preceding 1914. The figures are for the 276 years 1688 to 1914, £10,944,000,000; for the six years 1914-20, £11,268,000,000. Thirty-six per cent. of this latter sum was paid in revenue, and the remaining 64% was borrowed. The British people provided about £9,900,000,000 out of their own resources towards the six years' expenditure, or £215 per head. Though this vast expenditure was really the outcome of inflationary methods of finance, the system of inflation was not the same as that practised on the continent of Europe but was based on Treasury Bills or Ways and Means advances. These credit instruments were based not upon gold but upon currency notes. Inflation had the effect of reducing the pre-war unit of value: before the war the unit of value was the sovereign containing 123.274 grains troy of gold; in 1920 the unit of value was a paper pound representing no definite weight in gold, but varying in gold value from day to day. (C. J. M.)

ENGLISH HISTORY, 1910-1921 (see 9.466-582).—I. BEFORE THE WAR, 1910-12.—At the death of Edward VII. on May 6 1910, he was succeeded on the throne by his only surviving son as George V. (see GEORGE V.). The coronation at Westminster Abbey took place on June 22 1911, and was followed by State visits to Ireland, Wales, and Scotland; but an even more important act in the public assumption of Imperial authority was undertaken during the winter of 1911-2 in the visit paid by the King and Queen to India. At the Delhi Durbar (Dec. 12 1912), at which the King was crowned as Emperor of India, His Majesty announced that in future Delhi would replace Calcutta as the capital, and that Lord Curzon's unpopular partition of Bengal would be annulled. No hint of such an impending *coup d'état* as was represented by the latter announcement had previously leaked out, and no single act of Government in the history of the British constitutional monarchy had ever exhibited so strikingly the latent resources of the Throne as an extra-parliamentary factor in Imperial administration.

Without sending any communication to Parliament, the home Government had deliberately utilized the King-Emperor's authority to carry out an autocratic act of State policy in India, which otherwise could not have been accomplished without considerable friction.

(For a full account of the action here involved, see INDIA.)

It is only right to emphasize the interest attaching, at the opening of the new reign, to the position of the British Throne, as such. In the varied and exacting functions which it is expected to perform, much inevitably depends on the extent to which popular respect and affection surround the royal family. King George was able to benefit, in this respect, from a long growth of public confidence, and from the general acceptance of the theory that, so far as possible, the Crown should be kept out of politics in the party sense. It was all the more important, at King George's accession, that the personal popularity of the royal family should have been unquestionable, because of the political crisis amid which King Edward's death had occurred. Since the Lords' rejection of the budget in 1909 the whole course of domestic politics had been quasi-revolutionary; as between the contending political parties the *impasse* had become complete when the conference of 1910 broke down, and when immediately afterwards the second general election of that year gave the Liberal Government once more a majority. But the Crown remained by universal consent an imperial and social factor of all the more potential value as a moderating influence because of the warring of political factions.

"English" history to-day cannot indeed be written without reference to the British Empire, as a unit greater than is represented by "home" (i.e. English, Welsh, Scottish and Irish) politics (see BRITISH EMPIRE). The Imperial "idea," to which Mr. Chamberlain's administration of the Colonial Office and the emergency of the Boer War had given such a pronounced impetus, was already progressing with rapid strides at the opening of the new reign both in Great Britain and the Dominions. After 1909, moreover, the question of Imperial Defence had become acute, in consequence of the rapid increase of the German navy and its manifest challenge to British sea-power. The most remarkable incident during the Imperial Conference of 1911 was the confidential discussion of British international policy, at which the Colonial representatives were addressed by Sir Edward Grey with a detailed account of the situation in foreign affairs. For the first time, it was felt, the Empire as a whole had been taken into the counsels of the statesmen of the mother country. A naval defence scheme was adopted, providing for the maintenance of the various naval services and forces under the control of their respective Governments, but for making the training and discipline uniform with those of the fleet of the United Kingdom and for arranging an interchange of officers and men, while in war-time the Colonial ships placed at the disposal of the Crown would be under the British Admiralty. The movement for increasing the Colonial naval forces, as part of an Imperial policy acting as a single unit, was also notably forwarded by the visit to England of the Canadian Premier, Mr. Borden, with other Canadian ministers, in 1912.

for the purpose of discussing the whole subject with the Home Government and the Committee of Imperial Defence.

In connexion with the Imperial Conference of 1911 it may also be noted that resolutions were adopted by it in favour of: (1) an Imperial Naturalization Act, based on a scheme to be agreed upon, but still undefined, for conferring an uniform British citizenship throughout the Empire; (2) the appointment (carried out in 1912) of a royal commission, representing the whole Empire, to investigate and report on its natural resources, and the possibility of their development; (3) the establishment of a chain of British State-owned wireless telegraphic stations within the Empire (under the Marconi agreement of 1912).

The history of domestic British politics up to the outbreak of war in 1914 continued to be dominated by the state of the parties resulting from the general election which was precipitated in Dec. 1910 when the private conference between the Liberal and Unionist leaders on the constitutional crisis broke down (see 20.846, 847). The result of this second appeal to the constituencies showed that the short interval since the general election of Jan. 1910 had made practically no difference in the balance of party power.

The new Parliament opened in Feb. 1911 with a ministerial majority of 122, the combined forces of the Liberals under the leadership of Mr. Asquith as Prime Minister (270), with the Labour party (42) and the Irish Nationalists (84), numbering 396, while the Unionists numbered 274. In the Cabinet, Mr. Asquith, Mr. Lloyd George (Chancellor of the Exchequer), Mr. Winston Churchill (Home Secretary from Feb. 1910 till Oct. 1911 and then First Lord of the Admiralty), Sir E. Grey (Foreign Secretary), and Mr. R. B. Haldane, who was created a peer as Viscount Haldane in March 1911 (War Minister till July 1912, and then Lord Chancellor), stood foremost in dominating the manoeuvres of the Liberal party. Behind them in the House of Commons the most prominent members of the Ministry holding major offices were: Mr. Birrell (Irish Secretary since 1907); Mr. John Burns (President Local Government Board since 1909); Mr. Sydney Buxton (President Board of Trade since Feb. 1910); Mr. L. V. Harcourt (Colonial Secretary since Nov. 1910); Mr. Reginald McKenna (First Lord of the Admiralty from 1908 till Oct. 1911, and then Home Secretary); Mr. J. A. Pease (Chancellor of the Duchy of Lancaster from 1910 till Oct. 1911, then Education Minister); Mr. Walter Eustace (Education Minister from 1908 till Oct. 1911, then President Board of Agriculture); Mr. Herbert Samuel (Postmaster-General); Sir Rufus Isaacs (Attorney-General since March 1910) and Sir John Simon (Solicitor-General since March 1910). The Labour party was led by Mr. J. Ramsay MacDonald, and the Irish Nationalists by Mr. John Redmond.

In the Upper House Liberalism had but a small following, under the leadership of Lord Crewe (Sec. of State for India Nov. 1910), but it included Lord Morley (Lord President of the Council, Nov. 1910) and Lord Lorneburn (Lord Chancellor since 1905). Lord Rosebery continued to plough a lonely furrow, and Lord Courtney of Penwith to play the part of a political Aristides.

On the Unionist side, Mr. Joseph Chamberlain being physically incapacitated and now only an abiding inspiration to his political followers, Mr. Balfour had no rival as a parliamentary figure. He was loyally supported in the House of Commons by ex-Ministers in Mr. Austen Chamberlain, Mr. Walter Long, Mr. Bonar Law, Mr. H. Chaplin, Mr. G. Wyndham, Mr. A. Lyttelton, Sir R. B. Fintlay and Sir E. Carson (leader of the Irish Unionists). In Mr. F. E. Smith, K.C. (afterwards Lord Birkenhead), who had made a rapid and brilliant success both at the bar and in politics, the party had an indefatigable worker and an audacious master,—a good foil to Mr. Churchill.

In the House of Lords Lord Lansdowne was the recognized Unionist leader, actively supported by such ex-Ministers as Lord Halsbury, Lord Londonderry, Lord Curzon, Lord Middleton, Lord Selborne, Lord Cawdor, Lord Salisbury, Lord St. Aldwyn; and the Duke of Norfolk, Lord Cromer and Lord Milner were other important figures on the same side.

The Unionists were now halted by the demon-bond of resistance to the Radical-Socialist programme of their opponents. The precise form which the tariff-reform policy would take if the party were returned to power was debated according to varieties of opinion on electioneering tactics; but it was sufficient for the moment for these Unionist politicians who had opposed it altogether, or still wavered as to details, to await events. While a protective national economic policy was advocated by the Tariff Reformers as an essential condition of the improvement of industrial and social conditions at home, the Unionist leaders were looking anxiously to the wider Imperial issues beyond the solution of immediate domestic problems. Hopes were still entertained that, either by agreement between the parties or through the failure of the Ministry to obtain the King's consent to actual coercion of the House of Lords, the immediate constitutional crisis might be solved or the Government forced to resign or once more dissolve in circumstances more favourable than before to a Unionist success at the polls.

It was clear from the first that the Government could rely on the support of the Irish Nationalist party. The passing of the Parliament bill was an essential preliminary to the successful accomplishment of Home Rule, and it had been Mr. Redmond's policy ever since the elections of Jan. 1910 to press the destruction of the peers' veto to its final issue for that purpose. The only doubtful element in the situation was the Labour party. Its parliamentary programme included a "Right to Work" bill which the Liberal party could no more support than the Unionist; and having successfully extorted the Trade Disputes Act from Parliament in 1906, it was set on obtaining from the Government a bill for reversing the "Osborne Judgment" and freeing the employment of trade-union funds for political purposes. The fact, however, that the "Independence" of the Labour party was dominated by reluctance to put Liberalism in a minority, is so far as it stood for causes with which the Labour party also identified itself, made its parliamentary position one over the manoeuvring of which the Government's Whips had the upper hand.

On Feb. 6 1911, the first Parliament of George V, was opened. On Feb. 21, the Parliament bill was reintroduced in the House of Commons, and had a first-reading majority of 124 next day; the second reading was carried on March 2; and on the 15th the third reading was carried by a majority of 362 to 241, and the bill was sent up to the House of Lords. A few trivial changes had been accepted in its wording, but all the substantial amendments proposed by the Opposition had been negatived. A Labour party amendment to omit the words in the preamble, pledging the Government to set up a reformed Second Chamber, was rejected (May 2) by 218 to 47, Mr. Asquith declaring that the Government regarded it as an obligation, if time permitted, to propose a scheme for reconstituting the Upper House within the lifetime of the existing Parliament.

Every attempt of the Opposition to modify the operation of the Parliament bill was met by dogged resistance. The principal demand of the Opposition, that important constitutional changes should not become law, if rejected by the House of Lords, until they had been submitted to the judgment of the country, was of no avail. The Government's reply was that the country, in giving them a majority, knew quite well what the Parliament bill would be used for, and that the two years' interval it allowed for delay was an ample safeguard against legislation to which the people were opposed.

Meanwhile the alternative policy of the Unionist party was being made clearer in the more congenial atmosphere of the Upper House. A bill proposed by Lord Lansdowne for reforming its constitution was read a second time on May 22. The whole principle of this scheme of reform was that, while the composition of the Upper House would be changed and put on a representative basis, in accordance with the policy of Lord Rosebery's resolutions in 1910 (see 20.847), its powers would remain as they

*British in  
Parliament  
since  
1910.*

*The Parli-  
ment of the  
Government.*

*The Parli-  
ment bill.*

*The Action  
of the  
House of  
Lords.*

were: Under it, the reconstituted House would consist (except for royal princes) of "Lords of Parliament," summoned as such and not because of any hereditary title; 100 would be elected by the hereditary peers (from such among their number as were qualified, under a schedule to the bill, by having held various public positions or ranks in the public services; 120 would be elected to represent different districts of the United Kingdom by colleges of electors consisting of the members of the House of Commons for the constituencies within those districts; 100 would be appointed by the Crown (i.e. the Ministry) so as to represent the proportional strength of parties in the House of Commons; seven would be "spiritual lords," i.e. the two archbishops and five bishops to be elected by the Anglican Episcopate; and 16 would be peers who had held high judicial office. Except for the law lords, who would sit for life, and the spiritual lords, who would sit while they occupied their sees, the lords of Parliament would sit for 12 years, subject to one-fourth in each class (selected by ballot) retiring every third year. Peers who were not "Lords of Parliament" would be eligible for the House of Commons, but the creation of new hereditary peerages for commoners other than past or present Cabinet ministers was to be limited to five a year. In Lord Lansdowne's view, such a reform of the constitution of the Upper House, which followed on the lines of suggestions already thrown out by Lord Curzon and Lord Selborne, would provide a representative Senate, of which the existing Unionist party preponderance would no longer be characteristic.

So long, however, as the Government flatly declined to accept any reconstruction of the Upper House as a substitute for the Parliament bill, any such proposals were mere beating of the air. The actual scheme excited no particular interest on the Unionist side, and was assailed by Liberals on the ground that, according to their calculations, while pretending to be representative, it would simply stereotype a Tory majority. On the day after it was read a second time, the second reading of the Parliament bill was taken (May 23), and the real issue had to be faced; but the approach of the coronation, and the prevalence of a feeling that, in spite of bellicose utterances in the Liberal press as to the creation of 500 new peers for swamping opposition, the Government might still be forced to a compromise, made the debate still only a manoeuvre for position, and Lord Lansdowne decided not to divide against the bill but to propose amendments in committee.

The real fight only began when the coronation was over. The committee stage of the Parliament bill lasted from June 28 to July 6, and, in spite of warnings from Lord Morley that the Government would refuse, in the House of Commons, to accept them, Lord Cromer's amendment (June 28), substituting a joint committee for the Speaker in deciding what a "Money bill" was, and Lord Lansdowne's amendment (July 5), providing for a referendum in specific cases of measures attacking the existence of the Crown, the Protestant succession, or the establishment of national parliaments with legislative powers in Ireland, Scotland, Wales or England, were carried by large majorities. On July 20 the bill, so amended, was read a third time without a division, Lord Lansdowne declaring that the principal amendments were "so essential that we should certainly not be prepared to recede from them so long as we remain free agents." Lord Halsbury went still further: "but for the existence of the amendments, he would have himself moved the rejection of the bill on the third reading, and unless those amendments were accepted in substance, in meaning, and in operation, he would never consent without a division to the passing of the bill."

The next day the Government exploded their bombshell. It had been a mystery up to this moment whether Mr. Asquith had obtained from the King a definite assent to the use of the royal prerogative for creating peers, and the question whether such a course could possibly be resorted to had been freely discussed from the time when the Parliament bill was first proposed. All doubts were now set at rest. On July 21, a letter from Mr. Asquith

to Mr. Balfour in the following terms, written the day before, was published:—

"I think it courteous and right, before any public decision is announced, to let you know how we regard the political situation. When the Parliament bill, in the form which it has now assumed, returns to the House of Commons, we shall be compelled to ask that House to disagree with the Lords' amendments. In the circumstances, should the necessity arise, the Government will advise the King to exercise his prerogative to secure the passing into law of the bill in substantially the same form in which it left the House of Commons, and His Majesty has been pleased to signify that he will consider it his duty to accept and act on that advice."

In the subsequent debates in both Houses of Parliament (Aug. 7 and 8) on votes of censure moved by the Unionist leaders, the course taken by the Government was more fully explained. It appeared that the Cabinet had presented a memorandum to the King on Nov. 15 1910, before the general election, as follows:—

"His Majesty's ministers cannot take the responsibility of advising a dissolution unless they may understand that in the event of the policy of the Government being approved by an adequate majority in the new House of Commons, His Majesty will be ready to exercise his constitutional powers, which may involve the prerogative of creating peers, if needed, to secure that effect shall be given to the decision of the country. His Majesty's ministers are fully alive to the importance of keeping the name of the King out of the sphere of party and electoral controversy. They take upon themselves, as is their duty, the entire and exclusive responsibility for the policy which they will place before the electorate. His Majesty will doubtless agree that it would be inadvisable in the interests of the State that any communication of the intentions of the Crown should be made public unless, and until the actual occasion should arise,

The King had felt that he had no alternative except to assent, though he did so, as Lord Curzon now stated, "with natural and legitimate reluctance." The Government had hoped that, as the result of the general election, the Parliament bill would be allowed to pass without amendments which would be fatal to its purpose, and therefore without a disclosure of the confidential understanding which all the time existed as to the use of the prerogative, but this was no longer possible; the only question now was whether the threat was to be sufficient.

It was clear that in the House of Commons, the Lords' amendments would be summarily rejected by the Government majority. The further developments of the political situation depended, therefore, on what would happen next in the House of Lords when the bill was sent back to it. A hurried meeting of Unionist peers was held (July 21) at Lansdowne House, at which Lord Lansdowne informed them that the Government had told the Opposition leaders that their intention was not to send the bill up from the House of Commons unless an assurance was given that it would be passed, the assumption being that, in the absence of the assurance, peers would not be created in sufficient numbers for the purpose; and it was freely stated in the Liberal press that the Government Whips had a list ready of persons who were prepared to accept peerages on condition that they voted for the Liberal programme. A state of extreme excitation prevailed, but a considerable majority of Unionist peers agreed with Lord Lansdowne's view that, if this creation of peers were proceeded with, not only would the Parliament bill be passed, but even such opportunities as it left open for subsequent resistance to Home Rule and similar measures would be nullified; the only prudent course, in the interest either of the Unionist party or of the peerage, was to sink further opposition, now that they were no longer "free agents." On the other hand, a minority, whose view was strongly expressed by Lord Halsbury, bitterly opposed such a surrender; in their view they did not cease to be "free agents" until they were actually out-voted. It was in this sense that they had understood Lord Lansdowne's use of the phrase on the third reading and it was only on that condition that they had not rejected the bill then. They still regarded the Government threat as a piece of bluff. It was asked whether it could be regarded as certain that, when the 500 eligible magnates who were willing to take Liberal peerages had voted for the Parliament bill they would not take a more independent view of their position

*The Use of the Royal Prerogative.*

as far as Home Rule and other measures were concerned. The class of men whom Mr. Asquith was prepared to nominate for the purpose would hardly be different from those who in recent years had been added, quite acceptably, to the House of Lords by Liberal initiation in considerable numbers, and who had in many cases come round there to a different way of thinking. A further argument was that if a creation of peers was avoided now, it would not prevent its being resorted to if the House of Lords subsequently rejected the Home Rule bill.

Between these opposing views of the situation, a cleavage in the Unionist ranks was at once manifest. Mr. Balfour decided to "stand or fall" with Lord Lansdowne's advice, and they were followed by such the larger numbers; but public interest centred in what was known as the "Die-Hard" movement, which was actively organized under Lord Halsbury's leadership and initiated at a largely attended and enthusiastic dinner in his honour at the Hotel Cecil on July 26, at which Lord Selborne presided, supported by Lord Salisbury, Lord Milner, the Dukes of Northumberland, Marlborough, Bedford and Somerset, Mr. Austen Chamberlain, Mr. George Wyndham, Sir Edward Carson, Lord Hugh Cecil, Mr. F. E. Smith, Lord Willoughby de Broke, and other prominent men. How many peers would follow the lead given by Lord Halsbury and vote against the unamended bill when it was again sent up was still uncertain, but as Lord Lansdowne and the bulk of those who accepted his advice were only prepared to desist from further opposition, and would not assist the Government affirmatively by voting for a measure they detested just as much as the "die-hards," it was impossible for him to give Mr. Asquith the assurance he had demanded. A period of extreme tension and uncertainty followed. On July 24, when Mr. Asquith was to move in the House of Commons that the Lords' amendments be disagreed with, he was howled down from the Unionist benches, amid a scene of great disorder, which was repeated next day, and it was not till Aug. 8 that the motion for disagreeing with the Lords' amendments was carried by 321 to 215, after the Government had agreed to introduce a few minor changes. Meanwhile Mr. Balfour had endeavoured to placate the whole of the Unionist party by moving a vote of censure (Aug. 7), which was rejected by 305 to 246, and in the House of Lords a similar vote of censure moved by Lord Curzon (Aug. 8) was carried by 282 to 53.

The Parliament bill was sent up again to the Lords for their acquiescence in the striking out of their amendments; and the crucial debate there took place on Aug. 9 and 10. In answer to Lord Rosebery, Lord Morley made the precise statement that if the bill was defeated "His Majesty would assent to a creation of peers sufficient in number to guard against any combination of the different parties in Opposition by which the Parliament bill might again be exposed to defeat." This declaration had a marked effect on the result. Up to the last moment the figures on the two sides were in doubt, but the division showed 137 in favour of passing the bill, and only 114 for insisting on the amendments. The Government had won the day by the help of enough votes from peers who usually acted with the Opposition to counterbalance the "die-hards." Thirty-seven Unionist peers, the two archbishops, and 11 bishops voted with the Liberals; but Lord Halsbury's followers were more than had been expected, several peers, including the Duke of Norfolk, joining them in protest against the action of the Unionists who helped to carry the bill. Lord Cromer, who had been active in getting Unionist peers to support the bill on the ground that only in this way could the damage likely to accrue from a creation of new peerages be avoided, was absent through illness, and Lord Curzon's was eventually the most powerful influence exerted in this direction, his action being all the more hateful

\* It is worth noting in this connexion that between 1868 (when modern Liberalism and Conservatism practically started as organized parties) and Oct. 1912, the new peerages created by Liberal Governments numbered 164 and those created by Conservative Governments 149. Mr. Asquith alone had created 52 new peers up to Oct. 1912.

to the "die-hards" because earlier he had been especially prominent in counselling resistance to the bill at all costs.

The Parliament bill thus became an Act and duly received the royal assent; and a statutory enactment defining the relations between the two Houses of Parliament was substituted for an unwritten British constitution. *The bill as passed.*

As compared with the original form in which it was introduced (see 20,846, 847), various small drafting alterations were made, including an improved definition of a "money bill," and a more definite exclusion of private bills from the scope of the measure; but the only changes of any substantial importance were the following. (1) A provision by which the Speaker, before giving his certificate (to be endorsed on every money bill sent up to the House of Lords) that a bill is a money bill, "shall consult, if practicable, two members to be appointed from the chairman's panel at the beginning of such session by the committee of selection." (2) Provisions excluding from any public bills, as to which the Lords' consent would not be required after being sent up in three successive sessions, "a bill containing any provision to extend the maximum duration of Parliament beyond five years," and also "any bill for confirming a provisional order." (3) A provision altering the limits of the two years which must have elapsed during the three successive sessions to "between the date of the second reading in the first of those sessions of the bill in the House of Commons and the date on which it passes the House of Commons in the third of those sessions." (4) A provision requiring a certificate signed by the Speaker, stating that the provisions of the Act in this respect had been complied with, to be endorsed on any bill so presented to the King for his assent notwithstanding the opposition of the House of Lords. (5) A provision that "in every bill so presented to the King, the words of the enactment shall be as follows:—'Be it enacted by the King's most excellent Majesty, by and with the advice and consent of the Commons of this present Parliament assembled, in accordance with the provisions of the Parliament Act, and by authority of the same as follows.'"

In all vital respects the Parliament Act remained as originally introduced in 1911. Though its preamble declared that reform of the House of Lords itself still remained a task for the future, the supremacy of the House of Commons, both for purposes of finance and for public legislation, was definitely enacted. While the Act, however, on the face of it, made the Government masters of the situation, it was recognized by people who looked a little ahead that in practice it might not work quite as its authors contemplated. In order that its provisions should apply to the extent of bills becoming law over the resistance of the Lords, these bills had to be sent up in time for two years to elapse during the same Parliament, and during these two years they had to be sent up again and again without being changed from their original form. As the duration of Parliament was cut down to five (practically four) years, this meant that nothing not sent up in the first year or two would benefit by the Act; and apart from that, it would be difficult to avoid changes in bills sent up year after year. Even as regards "money bills," which the House of Lords was now to have no power of rejecting at all, the prospect was uncertain. The Budget of 1909, the rejection of which was the cause of the whole revolution, was probably considered a money bill by most radical politicians; but the Speaker (Mr. J. W. Lowther) upset any such calculations in Dec. 1911 by ruling, in answer to a question, that the Budget of that year was not a money bill within the Parliament Act—a fortiori, therefore, neither was that of 1909.

On the very day that saw the triumph of the Parliament bill (Aug. 10) yet another great alteration was being made in the essential conditions of parliamentary life. Following an invitation already given by Mr. Lloyd George, a resolution was carried in the House of Commons by 256 votes to 158, providing "for the payment of a salary at the rate of £400 a year to every member of the House, ex-

*Payment of members.*



duding any member who is for the time being in receipt of a salary as an officer of the House or as a minister, or as an officer of His Majesty's Household." Most of the Unionists were opposed to the proposal, and a good many Liberals did not like it, but the Government had determined to introduce payment of members as a way out of the difficulty they had with the Labour party, owing to the Osborne Judgment having made illegal the payment of salaries to working-class members out of trade-union funds (see 27:143). To legislate in the way the Labour party demanded, so as directly to reverse the Osborne Judgment, was impossible, though the Government were prepared with a bill—unsatisfactory to the Labour party and not proceeded with, a second edition being introduced in 1912—for enabling trade unions to make special provision for voluntary political funds, separately from the general funds to which every member of the union had to contribute; but it was hoped that payment of all M.P.'s out of public money would do away with the particular grievance of the Labour members. In the country generally a good deal of disgust was felt at the calm way in which M.P.'s had voted themselves £400 a year, and some members who were too well-off to want the subsidy declined to take it.

Further complications with Labour were being threatened all this time outside Parliament. Industrial unrest was taking a peculiarly acute and dangerous form. Though trade "Labour Unrest" generally was busy, and "unemployment" steadily diminished, the demand of the wage-earning classes for a proportionately larger share of the good things of life—better pay and less work for it—had become more articulate and better organised. Socialist—and particularly "Syndicalist"—theories had for some time been getting a strong hold of the younger generation of trade unionists; and a growing sense of the impotence of the Labour members in Parliament, added to increasing suspicion that Liberals and Tories alike were in league with the "money power," encouraged the idea that "direct action" by means of strikes was the only way of successfully asserting the claims of the operatives to a larger share of the profits of industry. The fact that wages, under existing agreements, practically remained stationary, while the cost of living, owing to higher prices, was going up, gave a solid basis for discontent. The result was seen, not only in numerous local conflicts between Capital and Labour, but in the threat of more extended "general" strikes, which aimed at holding up whole industries throughout the country and compelling parliamentary intervention.

For the first time in the history of English labour troubles a "national" strike was precipitated in 1902, and private war was made on the whole community by the members of the railway unions. Since 1907 there had been a continual agitation among members of the Amalgamated Society of Railway Servants for better wages and shorter hours, and for "recognition" of their trade union by the railway companies, which had been steadily refused by all except the North Eastern Company (after an arbitration in 1897). A general railway strike was only averted in 1907, as the result of negotiations carried on by Mr. Lloyd George as president of the Board of Trade, by an agreement between both sides to accept a scheme of conciliation and arbitration proposed by him. But the actual working of the conciliation boards then set up proved very disappointing to the railwaymen; and the movement came to a head again in Aug. 1911. Strikes had been going on in Liverpool, Manchester, London and elsewhere, among various other classes of transport workers—seamens, dockers and carters. In London a violent dock strike was only terminated early in Aug. by an award of Sir Albert Rollit, increasing wages; and a carmen's strike, which had been accompanied by serious disorder and had driven the Government to order troops from Aldershot, was brought to an end with considerable difficulty

The only official figures for "unemployed" issued by the Board of Trade were for the trade unions. In these the percentage, which was 9 in 1908 and 1909, fell to 5 in 1910 and 3 in 1911.

at the same time by the intervention of the Board of Trade, the men securing concessions both as to hours and wages. At Liverpool a protracted dock strike had driven the ship-owners on Aug. 3 to agree to "recognise" the Dockers' Union and make other concessions; but a number of strikers refused to go back to work; and the ship-owners then announced a general lock-out to begin on Aug. 14. The answer of the dockers' strike committee, led by Mr. Tom Mann, was to call on all transport workers to assist them by striking in sympathy, and wild scenes of rioting resulted, requiring the introduction of troops to help the Liverpool police. The general unrest now spread in an active form to the railwaymen too. At Liverpool the goods porters at the Lancs. & Yorks. stations struck on Aug. 5 because of the delay in dealing with their grievances, and at other stations the men came out in sympathy. On Aug. 15 the joint executives of the four railwaymen's unions—Amalgamated Society of Railway Servants, Associated Society of Locomotive Engineers and Firemen, General Railway Workers' Union, and Signalmen's and Pointsmen's Union—decided to order a general strike unless in 24 hours the companies agreed to meet them and discuss terms. The companies at once refused to do so, or to admit that the conciliation scheme of 1907 could be thrown over in this way. The leaders of the men on the other hand contended that the spirit, if not the letter, of the agreement of 1907 had never been carried out, and that they must have direct recognition of their unions. The machinery of the Board of Trade was set to work to try to delay a rupture, but meanwhile the companies were guaranteed military protection, and preparations were made for placing soldiers along the lines.

On Aug. 17 Mr. Asquith had an interview with the men's representatives, and offered a royal commission to inquire into the working of the conciliation scheme, but at the same time he warned them gravely and firmly that the Government could not allow the railway service of the country to be paralyzed. Resenting the tone of his speech, and suspicious of a royal commission as simply a means of shelving the whole matter, they refused this offer and ordered the strike, which began next day in spite of continued efforts by Mr. Lloyd George (Mr. Asquith having left further action to him) to overcome what seemed to be a misunderstanding. As the result of his explanations to the men's leaders negotiations still went on; a vote of censure on the Government which the Labour party at first decided to move in the House of Commons was not proceeded with; and instead of Parliament being adjourned on Aug. 28 until the autumn session, as had been arranged, it was decided to meet again on Aug. 22 in order to deal with the situation. The strike was in actual operation for practically two whole days and did not terminate till Aug. 20. On the 19th, however, a settlement was effected. It was agreed that a special commission should at once investigate the working of the conciliation scheme and report quickly what changes were desirable, and that the trade-union leaders should persuade the men to return to work, the strikers being reinstated. The special commission started work on Aug. 23 and took evidence from both sides up to Oct. 3, its report being issued on Oct. 20. It was unanimously recommended that the conciliation scheme should be amended in various ways, the central board being abolished and any differences within the sectional boards being settled by an independent chairman chosen from a panel drawn up by the Board of Trade; trade-union "recognition" by the companies was not directly conceded—the commissioners pointed out that the companies could not permit intervention on the subject of discipline and management—but some satisfaction was given in this direction by a recommendation that the men should have anybody they wanted (e.g. a trade-union official and not actually an employee) on the sectional boards as their secretary and advocate. The Labour party and trade-union leaders were by no means satisfied, however, with the result of the commission. The union leaders decided to take a ballot in Dec. on the question whether the findings of the commission should be accepted or another strike for "recognition."

started, and when the report of the commission came up for discussion in the House of Commons on Nov. 22 the situation was still a very difficult one. A resolution was moved by Mr. Lloyd George asking the Government to bring about a further meeting between the representatives to the agreement of Aug. 19; but this was only carried after a contentious debate displaying obstinacy on both sides, Mr. Ramsay MacDonald insisting that the men had not agreed to accept the report and that "recognition" was indispensable, while the view of the companies was that the Government ought to hold the report as binding on both parties. It was not till Dec. 11 that, after a good deal of diplomacy on the part of the Board of Trade officials, a compromise was arrived at. Both parties agreed to accept the report of the commission as a basis for modifying the future working of the conciliation scheme, "recognition" being accepted to the extent of allowing the men to have their trade-union secretary as adviser. Various concessions as to wages and hours were also made by the companies.

As regards the strike itself, while in actual operation, the state of the railways during those two or three days was unprecedented. Some 220,000 men altogether, about a third of the workers, were out, and traffic was much restricted, the worst dislocation being in the N. of England, round Liverpool and Manchester. Troops were employed freely to guard the lines and give protection against violence, and in consequence there were only certain particularly disturbed districts where serious mischief occurred. On Aug. 19 an attack was made by rioters on a train at Llanefly, and the soldiers had to shoot, two men being killed, while an explosion due to the mob setting fire to some trucks containing gunpowder resulted in five more deaths; and at Liverpool, on the 15th, two men were shot in a riot. The employment of the military was furiously denounced by the Labour agitators, but the intimidation practised against non-unionists and the danger of extended sabotage were such that, on the whole, the comparative peaceableness of the stoppage, which occurred in a summer of unexampled heat, was rather remarkable. To a great extent, and particularly on the lines nearer London, this was due to the fact that a large proportion of the union men who went out (a certain number remaining loyal to the companies) only did so because they dared not disobey the union orders. One outcome of the railway strike, and of the general unrest of which it was a symptom, was an addition made by the Government to the official machinery applicable at the Board of Trade to the working of the Conciliation Act of 1906. In Oct. 1911 an Industrial Council, representative of employers and workmen, was instituted as a permanent body for considering and inquiring into matters referred to them concerning trade disputes, and for taking suitable action (but without any compulsory powers) on the same lines as the conciliation boards already adopted in particular industries. As chairman of this Industrial Council and "Chief Industrial Commissioner," the Government chose Sir George Asikwith (b. 1861), head of the Labour Department of the Board of Trade, who had just been knighted in recognition of the valuable work he had done in recent industrial conflicts.

Meanwhile the National Insurance bill, introduced into the House of Commons by Mr. Lloyd George on May 4 1911, had brought new issues into the parliamentary conflict. This elaborate measure covered two distinct subjects, one being national health insurance, under newly constituted insurance commissioners for England, Wales, Scotland and Ireland (with a joint committee, formed from among them, for adjusting common affairs), assisted in each case by an advisory committee, with county and county borough committees for local administration, and the other unemployment insurance, directly under the Board of Trade.

(1) Unemployment insurance, administered largely through the labour exchanges, was applied to certain trades—building, construction of works (railways, docks, etc.), shipbuilding, mechanical engineering, iron-founding, construction of vehicles and saw-milleries—with power for the Board of Trade to extend the scheme to others. Workmen in these trades (shorter than 16 years, including apprentices, and persons under 16) would be entitled under various

restrictions to unemployment benefits up to a standard of 7s. a week for not more than 15 weeks a year, starting at the second week of unemployment), out of an unemployment fund formed by each workman compulsorily contributing 2d. a week (paid by employer and deducted from wages), employers 2d. a week per man, and the State adding an amount equal to a third of their total contribution.

(2) For national health purposes, compulsory insurance was imposed on all persons (between 16 and 70), under contracts of service, with certain exceptions (including those employed otherwise than in manual labour, and paid over £160 a year, or possessing £26 a year from property); provision being also made for certain classes of employed persons to come into the scheme as voluntary contributors. Under the compulsory insurance (except for certain lower rates) male contributors were to pay 4d. a week, female 3d. (employers making the payments and deducting them from wages), and employers 3d. for each male or female employed (special stamps for each amount having to be affixed to cards for this purpose), the State adding to the National Health Insurance Fund an amount (two-ninths in the case of men, and one-fourth in the case of women, of the cost of benefits and administration) reckoned at 2d. a week per head. The benefits primarily secured were (i.) free medical treatment at home, (ii.) sanatorium treatment for 21 weeks and other diseases specified by the Local Government, (iii.) the Government allocating £1,500,000 for the building of sanatoria; (iii.) payment during sickness of 10s. a week for men and 7s. 6d. for women up to 26 weeks; (iv.) subsequent payment during disablement of 5s. a week; and (v.) maternity bonus of 30s. to women (including wives of insured persons) on confinement, provisions being made for granting these benefits (medical attendance, sickness, and maternity benefits not till six months, disablement not till two years after payments started) or modifying and extending them as funds permitted. The agencies for administering the benefits were made (1.) "approved societies," i.e. the Friendly Societies, trade unions and such similar bodies as the insurance commissioners approved, the intention of the Government being to have as many as possible of the insured included as members of "approved societies"; (ii.) the post-offices, which would deal with those who would not join societies or whom societies would not admit, and who thus became "deposit contributors." The local health committees, among their other duties (including the administration of sanatorium benefits), were left to arrange for the service of medical practitioners for insured persons, preparing lists of doctors from among whom the patients were to have their own choice, payment to be made by the general fund being estimated for at the rate of the doctors from the drugs per head per annum. This feature of the bill, as explained by Mr. Lloyd George, quickly aroused the opposition of the doctors, who were organized under the British Medical Association to refuse their services unless a larger payment was made; and as a body the doctors stood out for better terms. As medical "benefits" under the Act became due on Jan. 15 1913, it became a question for the Government whether, if no terms could be arranged, a regular State medical service would not have to be started. On Oct. 23 1912 Mr. Lloyd George announced the Government's "final" offer to increase the capitation fee to 9s. (including drugs and extras); but on Nov. 19 the offer was rejected by an overwhelming majority of the profession at a representative meeting of the British Medical Association.

The second reading of the Insurance bill was carried without a division on May 29, and the committee stage went on intermittently from July 5 to Aug. 4, when, with the discussions on the 17th clause finished, Mr. Lloyd George was still able to regard the Opposition as favourably disposed towards the bill. Its remaining stages were then left over for the autumn session, which began on Oct. 24. But in the interval opposition had been growing, and the political situation in other respects was such that genuine co-operation with anything proposed by the Government was hardly possible if party capital could be made for the Unionists by what was unpopular in its programme. Not only were the doctors in full revolt against the terms proposed for their remuneration, but the working classes themselves were found to dislike exceedingly being taxed for benefits they were not able to appreciate. Mr. Lloyd George, ever an ardent electioneer, exasperated the Unionist party by his description of the bill as giving the working classes "nineteen for four pence." Among domestic servants the scheme was cordially disliked. Though the bill was planned so as to involve financial co-operation between the State and the Friendly Societies, there was considerable uncertainty, moreover, as to how far a great many of the latter, especially the smaller local societies, would reap advantage rather than loss. Public discussion concentrated on the difficulties and objections. It was inevitable therefore that, so far as the political aspects of the bill were concerned, the attitude of the Opposition should be affected by the discovery of its wide unpopularity.

The result was unfortunate for a scheme which aimed at accomplishing so important a work of social reform. The Government had its programme for 1912 full, subject to the way being cleared by the Parliament Act, by the political necessity of proceeding with Home Rule and Welsh Disestablishment; and Mr. Lloyd George, whose influence on the parliamentary tactics of the Coalition was now supreme, determined to force the Insurance bill through before 1911 ended. When the House of Commons returned on Oct. 24 Mr. Asquith carried a time-table resolution for closing the remainder of its stages; and by this drastic method the bill passed through committee on Nov. 21 and was read a third time on Dec. 6. Under such conditions the opportunity for effective Opposition criticism and amendment was so limited that very little was possible, in spite of the activity of Mr. Worthington Evans and other Unionist members, and towards the end it became a question whether the Unionist leaders would actually divide against the third reading, a course to which they were openly challenged by Mr. Lloyd George. Instead of this, an Opposition front bench amendment was moved by Mr. H. W. Forster, proposing that the bill should be postponed for further discussion, and this was defeated by 320 to 223; the third reading then being carried in a division in which the Opposition as a whole took no part, 22 members recording their votes against it. On Dec. 11 the bill was read a second time in the House of Lords, and, after various Government amendments had been inserted in committee on Dec. 14, it was passed and received the royal assent next day, when Parliament was prorogued.

During all this time, both inside and outside Parliament, opinion as to the scheme and its prospects had become more clearly crystallized. While Mr. Lloyd George and his supporters proclaimed it to be the most beneficial reform ever conceived in the interest of the working-classes, and taunted the Opposition with attempting to destroy it, the Unionists dwelt on the injury done by forcing through a measure which ought to have been more carefully considered before it became law, and threw the responsibility on the Liberal party for everything that was objectionable and unworkable in it. The by-elections showed that its unpopularity was continually growing; and under the arrangement made in the Act, that the insurance commissioners should during 1912 make regulations as to details, nobody knew yet what procedure would be adopted to overcome countless points of difficulty which under the Act itself remained quite unsettled. The medical profession, without whose co-operation, so far as could be seen, the Act would not work at all, continued to refuse it unless they were given better terms, to which Mr. Lloyd George was still unable to agree; and "passive resistance" was organized, on their behalf by the British Medical Association.

It was, however, not only the stimulus given by the antagonism to the Insurance Act that was causing a revival of Unionist confidence after the defeat over the Parliament Act. During the autumn session of 1911 the Unionist party had started afresh under a new leader in the House of Commons. The "die-hard" revolt had been a final illustration of the dissatis-

faction within the party at the way it had been led by Mr. Balfour for some time past. Had the Parliament bill been defeated in the House of Lords by the "die-hards," it was an open secret that both Lord Lansdowne and Mr. Balfour intended to retire from their positions at the head of the party, and it was largely the dislike of acting disloyally by them that confined the open revolt to a comparatively small section. Exasperation at the result, however, was general. Mr. Balfour himself did his best to smooth matters over, declaring in a public speech (Haddington, Oct. 7) that the question of the peers' tactics was now a dead issue, of no more practical importance than the controversy as to the identity of Junius; and the "die-hards," though they started a Halsbury Club and kept their organization in being, protested at the same time that the

differences within the party were ended with the cause of them, and that they only meant to work for the common good. But after some weeks of reflection, when the hubbub was all over, Mr. Balfour made up his mind that the right moment had arrived for him to retire from the leadership, though not from Parliament, in view of the arduous political struggles still impending, and the unlikelihood of his being strong enough in health, should the Unionists again return to power, to conduct a ministry. His announcement to this effect was made on Nov. 8, at a hastily convened meeting in the City of London. For a few days the question of who would succeed him was uncertain, Mr. Austen Chamberlain, not only as principal leader of the Tariff Reformers and one whose very name would, on his father's account, be most representative of the Imperialist movement, but as ex-Chancellor of the Exchequer and officially Mr. Balfour's deputy on the Opposition front bench, had apparently the strongest claim; but, as a Liberal Unionist, his selection was opposed by many Conservatives, who considered Mr. Walter Long a better choice; and Mr. Long's great popularity among all sections was much in his favour. It became clear to the partisans of both that if either were proposed, and votes were taken, it would only emphasize the division of opinion and create friction between their supporters.

It was found that Mr. Austen Chamberlain and Mr. Long were both prepared to stand aside in favour of Mr. Bonar Law, nominally a Conservative, and at the same time a *Man of the People* strong Tariff Reformer; and on their joint proposal *Law, the new leader*, he was quickly adopted as leader in the House of Commons (Lord Lansdowne continuing to be leader in the House of Lords), at a party meeting on Nov. 13. Their sacrifice of personal ambition set an example which did much to promote fresh confidence within the party; and Mr. Bonar Law had no sooner become leader than there were signs of improved Unionist prospects in the constituencies. In intellectual range, subtlety of exposition and criticism, and political experience, Mr. Balfour had, admittedly, no rival on either side, but he still remained in the fighting ranks, ready to devote himself to the Unionist cause, as much as anybody. His retirement from the formal responsibilities of leadership gave freer play to the respect and admiration felt for him personally as a public man, while relieving the party of the accumulation of doubt as to his policy and tactics, which, rightly or wrongly, had led to undercurrents of dissension. To the plain man his detached and philosophical outlook on public affairs had been rather too lofty; to be "had" or "ticked," as the party was openly taunted, with, being by its opponents, over the Budget of 1909 or the Parliament bill of 1911, simply meant that its leader had failed in astuteness; ardent Tariff Reformers, enthusiastic for Mr. Chamberlain's policy and pining for Mr. Chamberlain's aggressive tactics, felt that Mr. Balfour's balancing support of their proposals was unpractical and was confined to economic generalities. He was perhaps "too much of a gentleman," as well as "too little of a business man" for the situation. Mr. Bonar Law, on the other hand, was more of the Chamberlain type—a successful man of business, the clearest and most convincing platform exponent of Tariff Reform, a speaker who was accustomed to calling a spade a spade.

It so happened that the result of the Canadian elections at the end of Sept., and the defeat of Sir Wilfrid Laurier's American Reciprocity proposals, had delighted the Unionists and given them fresh confidence for the future of Imperialism. Canada had shown that she meant to keep her place in the Empire, and that antagonism to the prospect of becoming simply an annexe to the United States was more powerful than the temptation to secure immediate commercial advantages from reciprocity. Up to the last the result of the Canadian elections had been very uncertain, and the Tariff Reformers in England, who had been thoroughly depressed and disheartened by the idea that, if reciprocity between Canada and the United States were established, their hopes for Imperial commercial union would be frustrated, had in Mr. Borden's success a legitimate

triumph for their own views of Imperial policy. Imperial patriotism in Canada had averted the greatest danger yet threatened, in spite of the support given by the Liberal Government at home and the British Ambassador at Washington. Every platform rang with Unionist rejoicings, and the Canadian victory put new heart into the Tariff Reform propaganda.

On yet another question of Imperial moment a rebuff was given to the ministerial policy. Throughout 1911 the decision of the Government to ratify the Declaration of London had led to a prolonged agitation. Most of the

#### The Naval Prize Bill.

Unionist party, together with a strong body of naval opinion, were actively opposed to it; their argument being that under its provisions the advantages of British supremacy at sea in war time would be seriously diminished. The Government succeeded, however (June 1 1911), in obtaining the support of the Imperial Conference, considerable weight attaching to Sir E. Grey's view that adhesion to the Declaration would be advantageous in Great Britain's foreign relations and to the cause of peace. As Parliament had no direct control over the action of the Government in the matter of ratification, political opposition centred on the Naval Prize bill which was introduced to carry out the provisions of the Declaration of London, the second reading being taken on July 3. So much headway was made in arousing antagonism to the Declaration itself that when the third reading of the Naval Prize bill came on in the House of Commons on Dec. 7 the Government only managed to get a majority of 47; and the House of Lords promptly rejected the bill.

The Government were meanwhile being perpetually worn and worried by the militant agitation for women's suffrage and by the difficulty of dealing with any legislation on the subject when the Cabinet was divided. The Prime Minister himself was avowedly opposed to women's suffrage altogether. On the other hand, Mr. Lloyd George, while professing himself a strong supporter of the cause, which was also advocated by Sir E. Grey and Lord Haldane, objected to any bill which was not thoroughly "democratic"; and because the "militants" regarded his attitude as obstructing the particular measure which they had in view, and held him responsible for a Government bill not being introduced as they desired, he was pestered as much as if he had actually been an open opponent like Mr. Asquith. The so-called "Conciliation" bill, introduced by Sir G. Kemp, which assimilated the parliamentary to the municipal franchise for women and would give votes to about a million, had been read a second time in the House of Commons on May 5 1911, Mr. Asquith himself pairing against it while Mr. Lloyd George and other ministers supported it; and as there was no time for proceeding with the bill in 1911 the Government promised to give it "facilities" in the following year. But while the various sections of supporters of women's suffrage disputed about its prospects, and the "militants" raged together, Mr. Asquith suddenly made a new turn on Nov. 7 by announcing the intention of the Government to add to its programme a Franchise Reform bill on the lines of Manhood Suffrage. In answer to a deputation of woman suffragists on Nov. 17 he declared that, while he was personally opposed to women's suffrage altogether, this bill would be so drawn as to admit of amendment to include women on certain terms; and if an amendment, which the Government as such would not oppose, were carried, the Government would then adopt it. They would also, as had been promised, give facilities for the Conciliation bill.

#### The Finance Bill.

It had been generally supposed that the Government would take advantage of the passing of the Parliament Act to reintroduce the bill against plural voting which the Lords had rejected in 1906, but this larger measure was totally unexpected, and the announcement was widely construed simply as a device for "dishing" women's suffrage. It was at once denounced for that reason by the "militants" who began to make more trouble than ever. From this moment the internal divisions within the Cabinet on the subject of women's suffrage, and the necessity of taking administrative action against "militants"

violence, remained a source of constant difficulty. When eventually, on March 28 1912, the Conciliation bill was rejected by 222 to 208, owing to disgust at "militant" tactics, the prospect of legislative action rested entirely with the question of an amendment of the Government Franchise bill, which was read a first time on June 17 1912, by 274 to 50, and a second time on July 12, by 290 to 218. In other respects this bill, which abolished plural voting and university representation, made six months' residence by adult males the only qualification for votes, and did away with existing restrictions as to registration, handing it over for automatic action by the municipal authorities, excited comparatively little public interest. There did not seem likely to be time, even if there were inclination, to pass it into law before the session ended. The Unionists, while objecting to details, opposed it mainly on the old ground that redistribution should accompany reform; while the Liberal rank and file, who for their own electioneering purposes were principally anxious to destroy the plural vote, felt that a simpler measure with that object would have sufficed. A bill to abolish plural voting, introduced by a private member, Mr. Baker, was read a second time on March 1 1912.

The main problem, however, before the Government when Parliament met on Feb. 14 1912, was Irish Home Rule, with Welsh Disestablishment and Disendowment in a secondary place. The main interest of the latter measure, keenly as it was opposed in the interests of the Church of England, lay naturally in the financial provisions. The income of the Welsh dioceses in 1906 was £556,000 (£296,000 representing voluntary contributions which would be unaffected), and of the £260,000 derived from endowments the bill would take away £172,500, representing (according to the Liberal view) national property; but this reduction would only be gradually effected in about 20 years by the Welsh commissioners appointed to manage the transfer—existing interest being maintained and existing incumbents being paid their present stipends—so that in that time the Church would have the chance of making good the loss of income by increased voluntary contributions. The disestablished Church was given power to set up a representative body; and to this body the Welsh commissioners would hand over the cathedrals, episcopal palaces, churches and parsonages, and also the modern endowments—and such part of the glebe as was not considered to be part of the ancient endowments—to which the Church as such was strictly entitled; as a dividing line the date of 1662 was taken as that after which property of uncertain origin now owned by the Church might be regarded as her own. The funds which by degrees would be taken from the Church were to be applied partly to charitable and public purposes by being handed over to the county councils and partly to the university of Wales (library, etc.).

The rather moderate extent of the disendowment thus proposed was somewhat of a surprise. Extreme Liberationists had to console themselves with the prospect of a success for the principle of disestablishment rather than any considerable acquisition of Church property for secular purposes. On the other hand, from a Church point of view, the smallness of the operation on its financial side made the whole transaction seem one of peculiar meanness; for a paltry result, the work of the Church—admittedly now well done, as had been proved before the Welsh Church Commission, whatever its shortcomings in the past—was to be crippled and hampered. Defenders of the Church could point to the fact that it was the largest single religious body in Wales, and the only one which was represented in every parish by a regular organization. The ecclesiastical indivisibility of Wales and England was a more fundamental objection, the Welsh dioceses being from the Church point of view an integral part of the Church of England. The case for the Government, granted the principle of disestablishment at all, was, however, fairly simple. Their precedent was the case of the Irish Church in 1869: it was equally a part of the Church of England, and disestablishment and disendowment had done it good rather than harm. The answer to those who con-

tended that the Church really was the national Church of Wales was that the Welsh people thought otherwise; at election after election, almost unanimously so far as political representation showed, they demanded the change as an act of justice. On the first reading of the bill (April 25), which was carried by means of the closure by 331 to 253, Mr. Lloyd George emphasized this point in a somewhat rhetorical plea for the right of his own nationality to have the religion it chose and not to be nationally misrepresented by a Church which, however well it worked, was English and not Welsh. On May 13 the second reading opened with a slashing criticism from Mr. F. E. Smith, but on the 16th it was carried by the closure by 348 to 267, and the bill was then hung up till the late autumn. Its introduction satisfied the Welsh party, but otherwise it excited no real parliamentary enthusiasm. In recent years disestablishment had ceased to interest any large section of Liberal politicians; and the bill, while alienating many Liberal churchmen and rallying to defence of the Church numbers of voters who are normally indifferent to political issues, was not of a nature to help Liberal or Labour electioneering outside Wales itself.

In making an Irish Home Rule bill their chief measure in 1912 the Government were more fortunate in one respect than Mr. Gladstone had been in 1886 and 1893, when the whole Irish question was still associated in Great Britain with the prejudice and hostility aroused by the agrarian war, with all its incidents of cattle-maiming and boycotting, the "plan of campaign," the Phoenix Park murders and dynamiting outrages, the downfall of Parnell and the split in the Nationalist ranks (see IRELAND). A new generation had grown up, to whom all this was ancient history, with no special application to the existing conditions. Ireland for years had been peaceful and growing in prosperity; the Unionist Government had given her both local government and the Land Purchase Act; and the idea of Home Rule (as apart from the forgotten Home Rule bills) was now familiar simply as one of the standing issues of party politics. Lord Rosebery's defection had not prevented Sir Henry Campbell-Bannerman from inscribing it again in 1905 on the banner of the Liberal party; and though the Liberals then came into power, independently of the Nationalist vote, under a pledge not to introduce a Home Rule bill during the 1905-10 Parliament, Mr. Asquith had been quite explicit in saying, when the elections of Jan. 1910 were taken, that if he got a majority this self-denying ordinance would be at an end. It was true that at the elections of Dec. 1910 neither Mr. Asquith nor his colleagues in the Cabinet made Home Rule a direct issue either in their election addresses or in their speeches. On the contrary, when the Unionists warned the electorate that in voting for the Parliament bill they were voting also for Home Rule, they were constantly told that this was only a "bogey." But the fact remained that Home Rule was an integral part of the Liberal programme, and within the Government forces returned as supporters of the Parliament bill the Irish Nationalists held the balance of power. Mr. Redmond, for his part, had been perfectly frank about the conditions of his support; on Sept. 27, 1910, for example (to give only one instance out of many), at a moment when it was still uncertain to what lengths the Liberal Cabinet would go in framing a Home Rule bill, he was reported as saying in a speech at Buffalo, U.S., "I believe the leaders of the Liberals are sincerely friendly to Home Rule, but, sincere or not, we have the power and will make them toe the line." The real strength of his position for making a good bargain over the terms of the bill was based, however, on the willingness of the Liberal and Labour parties to concede, in all essentials, the Nationalist demand, representing as it did not only a solid vote from three-quarters of Ireland but also an important body of Irish opinion in America and the British colonies. Apart altogether from the oldest arguments for Home Rule, the Liberals justified their policy by the success attending their grant of self-government to the Transvaal, and by the congestion of business in the Imperial Parliament, which in any case made it desirable to move in the

direction of devolution. An Irish Parliament and executive of the colonial type for purely Irish affairs, subordinate to the Imperial Parliament, would not only satisfy the Irish claim, but might be the beginning of a federal scheme for the whole of the United Kingdom. Arguing on these lines, and Mr. Redmond carefully put the Irish case no higher in his speeches before British audiences—it was much easier in 1910 and 1911 for supporters of the Government than it was in 1886 and 1893 to scout Unionist objections to the principle of Home Rule; they could even appeal to Unionist arguments in favour of an Imperial federal constitution. English Liberal Nonconformists were not now so much agitated about Home Rule meaning Rome Rule; and public opinion in Great Britain generally had become rather apathetic about Ireland altogether, being to a large extent out of touch with its problems. It was only in Ulster that passionate resistance was as yet reawakened.

Mr. Asquith introduced the Government of Ireland bill in the House of Commons on April 11 1912. He laid particular stress on its being intended to be the first step towards parliamentary devolution and a system of federalized parliaments within the British Isles, and on its maintaining the supremacy of the Imperial Parliament at Westminster over the new Irish Parliament equally with any that might later be set up in other divisions of the kingdom. The essence of the bill was that in Ireland an Irish Parliament and Irish executive should be responsible for exclusively Irish affairs. Instead of saying precisely what these affairs were, the bill specified what were the Imperial affairs which the Irish Government could not deal with, including certain Irish matters (Clause 2) "reserved" to the Imperial Government. There would be two Houses—an elected House of Representatives of 164 members (of whom, on the existing basis, 39 would probably be Unionists); and a nominated Senate of 40 members, on which Mr. Redmond's view was that there would thus be the opportunity to secure the inclusion of Irish public men of eminence, without reference to their party colour. In case of a conflict between the two Houses they would sit and vote together. For Imperial purposes Ireland would still be represented at Westminster, but only by 42 members, subject to a special provision (Clause 26) for increasing this number in case the question of altering the financial relations should arise at some future time and purely for that purpose. The acts of the Irish Parliament would be subject to veto or postponement by the Imperial executive or Parliament, disputes as to their validity being adjudicated on first by the Irish Court of Appeal and secondly by the Privy Council. It might not enact privilege or disability, endowment or deprivation, for any form of religion, or make any religious belief or ceremony necessary to the validity of marriage. Irish taxes would be settled by the Irish Parliament but would continue to be collected (together with such Imperial taxes as remained) by the Imperial Government, and an annual sum corresponding to the cost of Irish services at the time of the passing of the Act would be "transferred" to the Irish Exchequer under the administration of a Joint Exchequer Committee, together with a grant, beginning at £500,000, to be reduced as circumstances permitted; practically this meant an annual subsidy of £2,000,000 from the Imperial Exchequer. The "transferred sum" would provide a security on which the Irish Government could raise loans. The financing of Old Age Pensions, National Insurance, the Post Office Savings Bank, and the Royal Irish Constabulary, was reserved temporarily to the Imperial Exchequer, but the Irish Post Office (with the postage attaching to it) was made a separate service under Irish administration. The powers given to the Irish Parliament included Customs and Excise as well as other taxation contemplated the setting up of Irish custom-houses independently of Great Britain, and (within certain limits) the possibility of varying duties as between goods imported into Ireland or into Great Britain; and as the collection was to be made by the Imperial Government, and allowance for the Irish to be made to the Irish by the Imperial Exchequer,

Home Rule Bill, 1912.

Home Rule Bill.

the procedure was necessarily rather complicated. The finances of the bill was indeed admitted, and necessarily provisionally complete data being unavailable, in spite of the Government's having had the advice of a committee of financial experts, whose report, however, was not disclosed. For 1912-3 it was estimated that the revenue derived from Ireland was £20,839,000, and the expenditure there £12,354,000, allowing a deficit of £7,515,000. In the next ten or fifteen years a further increase in the deficit was contemplated, bringing it up to over £9,000,000. The subsidy now proposed was estimated accordingly.

Even before the introduction of the bill it had been seen that the greatest practical difficulty in the way of Home Rule, in-

#### *Ulster's Opposition.*

respective of controversy over particular details in the scheme, would be that attitude of Unionist Ulster. Under Sir Edward Carson's leadership, opposition was already being organized in 1911, on behalf of the N. of Ireland Protestants and Orangemen, which, it was openly avowed, would if necessary go to extreme lengths, even to a refusal to recognize a Parliament in Dublin and to the setting-up of a separate "provisional government." The anxiety of the Government to counter this movement as far as possible had been shown early in the session by the announcement that Mr. Winston Churchill was going over to Belfast to speak on Feb. 8 in the Ulster Hall, and violent opposition to the proceeding was at once taken in hand there. It was considered on the Unionist side that for the son of Lord Randolph Churchill, who had said that "Ulster would fight and Ulster would be right," to preach Home Rule in a place associated with the campaign against it, was an outrage; and the leaders of the Ulster Unionist Council took steps to make the delivery of the speech in the Ulster Hall impossible. Eventually its engagement for the purpose was cancelled, and it seemed for the moment that the prospects of rioting and bloodshed if Mr. Churchill appeared in Belfast at all were so serious that the Government would be obliged to keep him away. Mr. Churchill, however, was not to be daunted. Arrangements were made for the speech to be delivered in a pavilion in a field outside the city, and for troops to be drafted there in large numbers for the maintenance of order. The apparent denial of free speech at all on the Ulster Unionist side was severely commented upon elsewhere, and justified with some misgivings by English sympathizers, but when the leaders had been successful in defeating the plan for holding a Home Rule meeting in the Ulster Hall they went no further. Mr. Churchill duly arrived and made his speech, dwelling particularly on the safeguards which the Home Rule bill would contain against anything to which Ulster could object; but the city was in a ferment of dangerous antagonism and he had to be smuggled away afterwards to avoid the hostility of the crowd. Actual rioting was avoided, and peace was kept between Nationalists and Loyalists, at the cost of £3,750 for the expense of the troops engaged, the Ulster leaders having eventually devoted themselves to keeping their supporters well in hand; but the whole incident was an unpleasant revelation of the rebellious spirit that was being aroused. A little later (April 9) Mr. Bonar Law was present at a great demonstration at Belfast, the special note of which was a solemn pledge of Loyalist resistance.

The Liberal press in England made light of these warnings, but the organization of opposition in Ulster went steadily on.

#### *Unionist Attitude.*

As controlled by the Irish Unionist leaders it was formally independent of actual parliamentary tactics, and therefore of the action of the Unionist party under Mr. Bonar Law's guidance; but Unionist opposition in Parliament and in the constituencies was inevitably concerned with what might take place in Ulster. Mr. Bonar Law, at Blenheim on July 27 and in the House of Commons on Aug. 5, took his side openly with the Unionists of Ulster. He said, the Ulstermen were forced into defiance of a measure passed under the Parliament Act without further appeal

to the electorate, and by the dictation of a Nationalist vote which had in their view always been disloyal to the Empire, any attempt to coerce Ulster could only mean civil war; and this could not be confined to Ireland; it was incredible that the Government should contemplate the coercion of Ulster by British bayonets, but if they went to that length the situation would be intolerable—ministers would be "lynched in London." Many Liberals hoped to find relief by proposing to leave Ulster out of the Home Rule bill, at least temporarily, altogether; but an independent Liberal amendment to this effect in Committee (July 18), after some ambiguous inquiries from the Government whether Ulster would be satisfied if it were adopted, was rejected by 320 to 172.

Meanwhile, on April 23 an Irish National Convention in Dublin, with Mr. Redmond presiding, accepted the bill, and the doubts as to whether Irish Nationalists might disagree over it and it might be snuffed out like the <sup>Provisional Bill</sup> Irish Councils bill in 1907, were dispelled. On July 19 Mr. Asquith addressed an enthusiastic meeting in Dublin, and was received with fervour as the first English Prime Minister who had had a welcome there in Nationalist circles. The first reading of the bill was carried in the House of Commons on April 26 by 360 votes to 266, and the second reading (April 30) on May 4 by 372 to 271. The Committee stage began on June 11, and on July 3 the first clause had gone through; discussion was then suspended till the autumn. On the Unionist side the objections to any scheme for a separate Irish Parliament and executive were fortified by criticisms of special features in the new bill itself—the finance, the proposal for Irish representatives to remain at Westminster, the separation of post-offices and custom-houses—but these subjects had still to be further discussed when Parliament adjourned in August. On the Liberal side a good many members disliked the provision for the nomination of an Irish Senate, and this question arose in Committee on Clause 31, but an amendment to exclude it was rejected (June 19) by 288 to 109.

Effective opposition was in Ulster, not in Parliament. Serious rioting between Protestants and Catholics in the Belfast shipyards during July showed the tension there; and on <sup>7th</sup> Sept. 14 a free fight between partisans of both <sup>Solemn</sup> <sup>Covenant</sup> sides, in the course of a football match at Belfast at which 20,000 people were present, resulted in injuries to about 100, revolvers and knives being used. Active preparations were on foot for a series of Unionist demonstrations in Ulster, leading up to the signing on Sept. 28 of a Solemn Covenant, pledging resistance to Home Rule. The perplexity on the Liberal side in face of Ulster's determination was shown by a speech of Mr. Churchill's at Dundee on Sept. 12, in which he suggested, purely on his own account, that, to secure a federal system of government for the United Kingdom,—to which Home Rule for Ireland, however, was an essential preliminary,—it might be desirable to grant separate legislatures to large homogeneous areas in England like Lancs., Yorks., the Midlands, and London; he would not shrink from the creation of 10 or 12 such English bodies, all subordinate to the Imperial Parliament. Mr. Churchill's speculation was effectively criticized by Mr. Balkour at Haddington on Oct. 9, the scheme being described as "the application of decimal fractions to the United Kingdom." What Unionist Ulster demanded was to remain under the Imperial Parliament and not be at the mercy of a parliament in Dublin.

The text of the Solemn Covenant, promulgated by the Ulster Unionist Council, was as follows:—

"Being convinced in our consciences that Home Rule would be disastrous to the material well-being of Ulster as well as of the whole of Ireland, subversive of our civil and religious freedom, destructive of our citizenship, and perilous to the unity of the Empire, we, whose names are underwritten, men of Ulster, loyal subjects of His Gracious Majesty King George V., humbly relying on the God Whom our fathers in days of stress and trial confidently trusted, hereby pledge ourselves in Solemn Covenant throughout this our time of threatened calamity to stand by one another in defending, for ourselves and our children, our cherished position of equal citizenship in the United Kingdom, and in using all means which may be found necessary to

<sup>1</sup> The anniversary of "Craigavon Day," Sept. 23 1911, when Sir E. Carson was acclaimed the Ulster leader, and the Declaration of Ulster was published to the above effect, was celebrated in 1911.



defeat the present conspiracy to set up a Home Rule Parliament in Ireland; and, in the event of such a Parliament being forced upon us, we further solemnly and mutually pledge ourselves to refuse to recognise its authority. In sure confidence that God will defend the right, we hereto subscribe our names, and, further, we individually declare that we have not already signed this Covenant.

Sir Edward Carson signed first, on Sept. 28, at the head of a great gathering in Belfast. And when, just afterwards, he crossed with Mr. F. E. Smith to Liverpool, he had a remarkable ovation, violent speeches being made by sympathisers with the cause of Ulster, in favour of supporting her resistance by force of arms. It was announced later that the total signatures to the Covenant were:—Ulster, men 218,206, women 228,091; Outside Ulster, men 19,162, women 5,655.

Reference must now be interposed to the progress of the industrial unrest in England, culminating during 1912 in the general strikes of coal-miners and transport workers.

*National Coal Strike, 1912.* For some time past trouble had been brewing in the coal industry. In Dec. 1910 a strike had begun at the Cambrian Combine Collieries (of which Mr. D. A. Thomas, afterwards Lord Rhondda, was managing director), owing to the failure of the two referees (representing owners and men) appointed by the South Wales Conciliation Board to agree upon a tonnage price for the working of a seam at the Ely Pit, which had till then been worked on day-work.

The rates offered by the owners were denounced by the strike committee as a "starvation" wage; but the strike was really a forward move on the part of the younger extremists among the men, who had obtained the upper hand and were influenced by socialistic doctrines. A general lockout of the men working in other seams in the Ely Pit was the masters' reply. The Welsh Socialists then sent delegates to enlist sympathy among the English and Scottish miners elsewhere, and to try to bring about a general strike; but the leaders of the Miners' Federation of Great Britain were not prepared to support the action of the Ely Pit strike committee, and financial support was withdrawn, so that the strike collapsed.

The Miners' Federation next put a claim before the owners in the federated area for the fixing of definite rates of payment in the case of "abnormal places" where the men were unable to earn an average day's wage for no fault of their own. At the Southport conference of miners' delegates in Oct. 1911 the following resolution, proposed by the executive, was unanimously passed:—

"That the federation take immediate steps to secure an individual minimum wage for all men and boys working in mines in the area of the federation, without any reference to the working places being abnormal. In the event of the employers refusing to agree to this, the 21st rule to be put into operation to demand assent.

At a second conference on Nov. 14, at which the refusal of the employees to accept the minimum wage was reported, an adjournment was resolved on (by 336,000 votes to 238,000) for future negotiations; and on Dec. 21, the situation remaining the same, it was resolved that a ballot should be taken on Jan. 10-12 1912 on the question: "Are you in favour of giving notice to establish the principle of a minimum wage for every man and boy working in the mines of Great Britain?" A resolution was also passed "that each district send to Mr. Ashton (general secretary of the Miners' Federation) a tabulated statement of what it desires to be its minimum wage, and that the executive committee of the Federation meet to consider the statements and report to a national conference in Birmingham on Jan. 18 1912." The result of the ballot showed 445,807 votes for giving notice; 115,721 against;—majority 330,080.

It must be remembered, of course, that "Ulster" as an Irish political unit did not mean the whole province, but only the N.E. portion comprising the five counties of Antrim, Armagh, Down, Londonderry and Tyrone, with the cities of Belfast and Londonderry. As a geographical unit Ulster had a pop. (1911) of 1,581,696, but the N.E. portion by itself had 1,188,695. Out of the latter total, those of 16 years old and over were 387,241 males and 438,774 females. As the census classification showed that 33.1% of the pop. in this N.E. area was Roman Catholic, the number of adult male Protestants in Ulster who might be expected to sign the Covenant was not much in excess of those who actually did so.

South Wales alone giving a majority of 85,207 for stopping work. And on Feb. 2 1912 a definite schedule of the minimum rates asked for was approved.

The coal-owners met on Feb. 7, and the Welsh owners there refused to discuss any minimum wage, and withdrew from the conference. This made a strike inevitable, since the miners were not prepared to settle with any but the whole federated area. Notices were given accordingly, the public being faced with a prospect of a complete cessation of coal supplies. The Prime Minister on Feb. 20 invited both sides to meet him to discuss means of averting a national stoppage, and their representatives met him on Feb. 22, but to no purpose; and on Feb. 26 the first miners went on strike at Alfreton, the rest soon following, in spite of the announcement that the principle of a minimum wage was now adopted by the Government and that they would take steps to give it parliamentary sanction unless an agreement were arrived at. On this point a split occurred between the coal-owners, those of Durham and the federated districts being prepared to fall in with the proposal of the Government, and the others refusing. On March 1 over a million coal-miners were out (Yorks. and N. Midlands 235,000; S. Wales 222,000; Scotland 130,000; Northumberland 120,000; Durham 110,000; Midlands and South 205,000; N. Wales 20,000; N. and E. Lancs. 45,000), and during the whole month the country was convulsed by the calamity.

At last, after the Government had made a further unsuccessful attempt, by a conference, to bring owners and miners to agreement, on March 20 1912 Mr. Asquith introduced in the House of Commons a Minimum Wage Bill as their last resort. It provided that, in the coal industry, every contract for employment should involve the payment of a minimum rate, to be settled for each district by a joint board set up under the auspices of the Board of Trade. The bill was read a second time on March 22, after a motion for its rejection by Mr. Balfour, on behalf of the Opposition, had been defeated by 248 votes to 225, and it had passed both Houses on March 28. Having made their protest against a piece of revolutionary legislation which introduced so novel and far-reaching a principle into industrial economics, the Unionists left the responsibility to the Government, and the only parliamentary difficulty was caused by the Labour party, who fought for the inclusion of a precise definition of the minimum in the shape of 5s. a day for adults and 2s. for boys; as the Government refused this and insisted on the rates being fixed by the district boards, the Labour party opposed the third reading, which, however, was carried by 213 to 48. There was acute dissatisfaction among the miners at the failure of the Labour party to get their own minimum schedule of rates adopted, and for a time the result was doubtful; but it was decided to take a ballot (April 1) on the question of returning to work, and though a majority still voted for staying out (244,011 to 202,013) it was not large enough (two-thirds being required by the rules).

The fact was the funds were exhausted and the men had had enough of the struggle. The conclusion of Sir A. Markham, the Liberal M.P. and coal-owner, writing in the *Quarterly Review* for April 1912, is probably the verdict of history; he considered that "the ground of attack was ill-chosen; the men should have stood to their original demand, the payment on account of abnormal places or losses due to bad management. If in addition they had asked for an increase of wages equivalent to 10% on the basis rates, to meet the increased cost of living, they would have occupied strong ground." The great mass of men came out to obtain higher wages, and for no other reason; and when they voted for the formula "minimum wage" nine-tenths did not know what they were voting for." The result, as the year went on and the minimum rates were settled, not without friction, was a profound disgust among the coal-masters generally with the operation of the new Act, which was found to do very little to increase the amount paid in wages; but it had done its work for the moment, the crisis being over. In Oct., moreover, an agreement was arrived at between repre-

representatives of miners and coal-owners of the English federated area, by which about 400,000 workers would at once receive an advance of a shilling a week in wages. This was the outcome of discussions before a Conciliation Board, which had been in existence for some years and was now renewed for a further period; and this addition of about £1,000,000 a year was worth more than all the haggling about minimum rates.

In connexion with the opening phases of the railway strike of 1911, allusion has already been made to the sporadic strikes of other sections of "transport workers" earlier in the year, and the general dock strike, which began in London on May 20 1912, was really the concluding phase of the unrest which had been only partially quieted during the previous August. First the lightermen came out, and then a "sympathetic" strike involved all the other unions of transport workers connected with the Port of London. The nominal reason for the lightermen ceasing work was their objection to one man employed as a watchman having no "federation ticket"; he belonged to the Foremen's Society, a union not affiliated to the Transport Workers' Federation, but refused to join the Lightermen's Society, which was so affiliated, and when the lightermen demanded his dismissal, on the ground that they would work only with men who belonged to the federation, his employers naturally refused. This was, however, in reality only the culmination of a number of "grievances" put forward by the men, who complained of being victimized under the terms of the existing agreements. Unsuccessful negotiations had for some time been going on between their secretary, Mr. Gosling (himself actually a member of the Port of London Authority), and the Board of Trade, with a view to pressure being put on the employers; and the declaration of a strike on May 20 for the reason given was prompted by the hope that the hands of the Government would be forced. In taking this step the lightermen relied on their privileged position in the Port of London. Their Society held an old licence from the Watermen's Company, whose functions were transferred in 1908 to the new Port of London Authority, and the law was that unlicensed men should not be employed so long as licensed men were available, so that, apart from the difficulty of obtaining substitutes in an emergency, the employers, as they knew, would have to reinstate them when the strike was over. (One result of the strike was that the Port of London Authority took steps to get this law altered.)

The Federation of Transport Workers now took up the lightermen's cause, and in doing so put forward a further grievance on behalf of the Carters' Union, by whom an agreement had been made with the Master Carters' Association when the strike of the previous August was settled. The complaint was that one firm which had joined the association had dismissed their union men, contrary to the terms accepted, and had resigned from the association when it called them to account; so that the agreement was useless. The union demanded accordingly that all employers in the Port should be obliged to belong to a masters' federation, which would have power to guarantee the carrying-out of agreements. As no concession on this point was forthcoming, notice of a general strike of all members of the Transport Workers' Federation was given.

The Government at once took action by appointing Sir Edward Clarke, K.C., to hold an inquiry on May 24. He made his report on May 28 to the effect that, while the lightermen were wrong in supposing that the award of the previous Aug. meant that none but members of their federation should be employed, and they themselves had broken their agreement by striking without recourse to arbitration, still there were several points on which the transport workers had legitimate grievances, owing to the employers not having carried out certain terms of their agreements also. The Government on May 29 suggested a conference between the two sides, which was, however, declined by the ship-owners, who insisted that the only point really at issue was the lightermen's breach of agreement in

suspending work and thus disrupting the whole business of the Port. Meanwhile a general strike of transport workers was in progress at the docks, some 80,000 men being affected, and the whole food supply of London was threatened; but the ship-owners actively engaged "free" labourers in spite of trade-union picketing and intimidation, and day by day managed more efficiently to get their ships unloaded. Public discussion, influenced by Sir Edward Clarke's report, and its criticism of both sides, centred round the apparent necessity of providing, alike for masters and men, some guarantee against breaches of agreements; and Mr. Lloyd George, who in Mr. Asquith's temporary absence in the Mediterranean dominated the Government policy, made proposals, which he explained in the House of Commons on June 5, for a Joint Conciliation Board, combined with pecuniary guarantees on both sides. Mr. Gosling, on behalf of the transport workers, gave a general assent to this suggestion, but the employers and the Port of London Authority (with Lord Devonport—formerly Mr. Hudson Kearley, a well-known Liberal M.P.—as chairman), after careful consideration, rejected it on June 10. It was pointed out by them that there was no proper basis, under the conditions prevailing at the docks, for such a board, the trades concerned being very different and the employers (some of whom were foreign firms) themselves being competitors; the Port of London Authority moreover was a statutory body, with distinct obligations and responsibilities, and could not well enter into such an arrangement, any more than a Government department could—the Post Office, for instance—with the men in its employment. This was not a case of a strike against some individual firm which had given legitimate cause of offence, but a general strike against the whole Port, defying all agreements.

Negotiations now broke down altogether, and the leaders of the Transport Workers' Federation declared a "national" strike and tried to call out all its allied members at other ports as well as London. But though some 30,000 men responded altogether at Manchester, Southampton, Bristol, Plymouth and Swansea, this appeal for a "national" strike was a thorough failure; the railway unions had had enough fighting the year before and the seamen and firemen, as a body, were not prepared to come out. Scenes of violence were of daily occurrence between unionists and free labourers at the London docks; but by June 18 it was clear that the Port of London Authority and the employers, aided by police protection (which Mr. McKenna, the Home Secretary, provided, though somewhat grudgingly), had the strikers well beaten, having obtained a sufficient supply of labour for the handling of cargo: From this point, the strike degenerated into sheer anarchy. Serious conflicts occurred, in which revolvers were used in self-defence by the free labourers, notably on July 24 and on July 31; but by degrees the strike committee realized that their efforts were in vain. They recommended a return to work on July 27, but a mass-meeting in Hyde Park next day refused to comply with this advice, and it was not till a week later that all pretence of continuing the strike was abandoned. On July 31 the lightermen decided to give in, and the riot among the dockers that day was mainly due to their finding that their old places had been filled up and that it no longer rested with them to say whether they were wanted any more or not. On behalf of the employers, however, and of Lord Devonport, a general assurance had been given that, if the strike were abandoned unconditionally, any outstanding grievances under the old agreements would be inquired into and reinstatement effected as soon as possible for men who had formerly been in regular employment; and, as the strike committee and the leaders could hold out no longer, further resistance came to an end.

The real object of the strike, in so far as it aimed at being a "national" one, was to compel Parliament to legislate, as it had done for the coal-miners. In this case, however, the Labour politicians and their sympathizers were impotent. The discussions in the House of Commons turned mainly on Unionist criticism of the Home Secretary for the apparent discrimination he showed for using

force to preserve order and protect the free labourers. On June 12 Mr. Austen Chamberlain moved a vote of censure on Mr. McKenna, which was rejected, however, by 337 to 260. On July 1 Mr. O'Grady (Labour M.P. for E. Leeds) moved a resolution "that it was expedient that the representatives of the employers and working men's organizations involved in the dispute should meet with a view of arriving at a settlement," and Mr. Asquith left the matter to the House, saying that he himself would not vote on it, as he did not think Government intervention would be justifiable or expedient. Mr. Bonar Law, for the Unionists, having expressed his surprise that in those circumstances Mr. Asquith did not oppose the resolution, moved as an amendment, "that this House regrets the continuance of the strike and the consequent suffering, and approves of the declaration of the Prime Minister that the constitutional and normal attitude of the Government should be one of complete detachment and neutrality, and is of opinion that the intervention of this House in this instance can serve no useful purpose." The amendment was rejected by 260 to 215, and the resolution was carried by 254 to 188. This was the end, however, of any parliamentary action. The strike was already collapsing, and its only political result was to focus public opinion on the desirability of compulsory arbitration, or at any rate some improved machinery for making agreements, once entered into, binding on both sides.

Parliament met again for the autumn session of 1912 on Oct. 7, and the political conflict was once more renewed in the House of Commons. The effect of the Ulster demonstrations on the Government, up to this point, had not been specially terrifying; and Mr. Asquith, speaking at Ladybank on Oct. 5, dealt somewhat scornfully with Sir Edward Carson's movement and the Unionist attitude towards it. The Government, he intimated, were ready to consider any proposals for safeguarding Ulster, but Ulster had nothing to suggest—she simply would not allow Ireland to have what the other four-fifths of Ireland demanded. It was impossible for the Government to give way to intimidation, prompted by the spirit of Orange ascendancy; they meant to go on with their bill. On Oct. 10 he introduced in the House of Commons a series of resolutions for completing the various stages of discussion on it by Christmas under the closure. Including the time already occupied, 50 days (to which two were added a few days later) were, on this scheme, to be devoted to debate. An Opposition amendment, proposed by Mr. Bonar Law, was defeated by 223 to 232. The operation of the guillotine, combined with the "Kangaroo" system by which the chairman of committees was left to choose which among the various amendments proposed should be discussed in the time available, made the resumption of the committee stage simply a question of whether the Government could maintain their majorities; any effective debate was obviously impossible, and Mr. Bonar Law bluntly declared that the Government might just as well have moved that the bill should be passed without further delay. On the other hand it was equally true that, without such a time-limit, the Opposition would have protracted the debates indefinitely; the Government had no option in the matter if they were to send the bill up to the House of Lords during that session, as they must, in order to obtain the benefit of the terms of the Parliament Act. Even if the Home Rule bill were to be passed through the House of Commons by Jan., the Government programme was over-loaded, for they had announced their intention also to pass the Welsh Disestablishment bill, the Franchise bill and other measures, before the session ended.

At the same time, with Mr. Lloyd George's active encouragement, yet another political issue was being made prominent throughout the constituencies, in the shape of an organized agitation for land-tenure reform and increased taxation of land-owners, promoted more particularly by a section of the Radical party who had long been advocates of the single-tax theory on Henry George's lines. The Budget of 1909 (as incorporated and passed in the Finance Act of 1910), with its provisions for effecting a complete valuation of the land,

paved the way for such a movement, and the land-reformers saw their opportunity now for pushing their views and preparing for legislation. The fact, indeed, that the yield of the new land-value duties in 1911 and 1912 proved disappointingly meagre had even driven them to seek this extension of policy. For, with the comparatively humdrum budgets of those years, the critics of "Lloyd George finance" in that respect were already taunting it with utter failure. The unpopularity of the Insurance Act made it opportune, moreover, for Mr. Lloyd George's section of the party to try to divert electioneering attention on the Radical side to something more attractive, and at the summer and autumn by-elections the new land campaign was made a leading feature by Radical candidates. Intense exasperation was created on the Conservative side, representing as it did to so large an extent the landed interests of the country, by the organization of an unofficial committee of inquiry under Mr. Lloyd George's auspices, with the authority of the Cabinet, in order to obtain evidence of various sorts of agrarian grievances in furtherance of a new Radical policy.

An important change in the Home Rule bill was made when on Oct. 30 the discussion in committee reached clause 8, concerning the composition of the Irish Senate. It was suddenly announced by Mr. Asquith that, while the proposed nomination of the first senators by the Imperial Government would be adhered to, the Government had decided to abandon the idea of their successors being nominated by the Irish Government. Instead of this, the method would be substituted of election by the voters in the four Irish provinces, taken as units, on a plan of proportional representation, each elector having a "transferable" vote (see 23.115). The term of office for senators would be five years, and all would retire together at the end of the fifth year so that the elections might then be taken. The next day (Oct. 31) the revised clause was introduced and carried. Mr. Asquith insisted that it would be an additional safeguard for the Unionist and Protestant minority in Ireland, but Mr. Bonar Law regarded it as worthless for any such purpose, and Mr. Healy frankly declared that in his opinion the Irish Unionists would have been better off with the method of nomination. Mr. Redmond, while accepting the Government's decision, expressed much the same view. The fact was that the whole idea of a nominated Senate was distasteful to most of the Liberal party, and it seemed a favourable opportunity for putting the experiment of proportional representation, which had recently made many converts, into practice.

On Nov. 3 Mr. Asquith introduced a "guillotine" timetable for the Welsh Church bill, allocating 14 days to the committee stage, two to report, and one to third reading. So short a shift excited much bitterness on the Opposition benches, the discussion that day being adjourned; and on Nov. 11 the situation in the House of Commons was changed by an unforeseen event. On a resolution required as a preliminary to discussion of the financial clauses of the Home Rule bill Sir F. Banbury moved an amendment without notice, providing that the total payment from the Imperial to the Irish exchequer in any one year should not exceed £2,500,000. It was early in the afternoon, when the Unionists were in unaccustomed force, and the Government was defeated by 228 to 206. Mr. Asquith immediately moved the adjournment of the House; and next day it was announced that the Cabinet had decided to move a resolution rescinding the vote and providing (so as to regularize further proceedings under the time-table, which was entirely upset by the incident) that the next day on which business was taken on the Home Rule bill should count as the "16th allotted day," though, as previously fixed, the 16th day was Nov. 11; when this had been done, they proposed to reintroduce their financial resolution and proceed as though nothing had happened. On the 13th Mr. Asquith accordingly moved to this effect. This proposal to rescind the vote and set up the resolution afresh was, however, as the Speaker agreed in reply to Unionist objections, absolutely unprecedented in parliamentary procedure.

It had always been held, and was laid down by Erskine May, that no question or bill could be brought up in the House that was substantially the same as one on which judgment had already been expressed in the current session; and when the Speaker nevertheless ruled that Mr. Asquith's motion, though unprecedented, was in order, Opposition exasperation became intensified to a point beyond control. After Mr. Bonar Law had argued the case at length, and had moved the adjournment of the debate, which Mr. Asquith curtly declined to accept, a state of organized disorder prevented any further proceedings. The Speaker at last took the only course open to him, and adjourned the House. There seemed likely to be renewal of the same scene next day, but calmer counsels prevailed. At the opening of the sitting the Speaker suggested that, if more time were given for reflection, a less objectionable way might be found for regularizing the proceedings. Mr. Asquith promptly accepted this suggestion, and moved that the House should adjourn for the purpose till Monday the 18th. As Mr. Bonar Law concurred, this course was adopted, and the anticipated storm was avoided. The air had previously been cleared to some extent by amendments being made by Mr. Ronald McNeill for the most violent incident in the disorder of the previous evening. In the heat of the moment he had thrown a book at Mr. Winston Churchill which struck him a severe blow on the face; but he now offered a handsome apology.

The Liberal press was inclined to treat the opposition to Mr. Asquith's motion as purely factious, and the organized disorder as a further mark of deterioration in parliamentary manners. But the historian cannot well take this simple view. The defeat of the Government was certainly an accident, but it was the sort of accident that happens when a number of nominal supporters are not personally enthusiastic for the particular cause involved, or are being tired out by excessive demands on their attendance. The opinion of a high independent Liberal authority on procedure, Mr. James Caldwell, ex-M.P. and formerly chairman of committees, was moreover that Mr. Asquith's proposal for meeting the new situation was "clearly out of order" (*The Times*, Nov. 16), although not so ruled by the Speaker. Owing to the critical state of foreign affairs, consequent on the situation in the Balkan War, a change of government, as Mr. Bonar Law frankly admitted, was not at this moment desirable; and if the Government chose to ignore what was formally a parliamentary defeat their normal majority was still available. But the Opposition were naturally not prepared to forgo what, according to the practice and precedent of Parliament, was a legitimate opportunity for impeding the execution of the Government's programme of legislation for the session; and they gained their point. On Nov. 18 Mr. Asquith made an amended proposal, which was agreed to without further discussion, that the financial resolution should simply be negatived that day and the committee stage on the financial clauses of the Home Rule bill set up afresh on the 19th by the introduction of an amended resolution, the report stage of which would be taken on the 20th, so that the next "allotted day" (the 17th day under the time-table) would be on Thursday Nov. 21. This course was accordingly pursued.

After the scare in the Government ranks caused by the misadventure of Nov. 11 and its immediate consequences, the resumption of proceedings on the financial clauses of the Home Rule bill saw their normal majority well kept up, and the guillotine fell with merciless regularity. Faced with a hostile and unreformed House of Lords, whose certain antagonism could only be defeated by sending the bill up in time to obtain the benefit of the Parliament Act, the Coalition were compelled to restrict discussion in the House of Commons; and it might well be thought on their side that at this stage, since in any case the Parliament Act involved nearly two years' delay, it was futile to attempt to examine every detail in a scheme which was approved in principle, but which still had a long fight before it. On the other hand it was incontestable that, for a measure of such profound importance, supposing it to be one that might come

into operation as it left the House of Commons, the discussion of the various difficult and obscure aspects of the new financial relations proposed between Ireland and Great Britain was entirely inadequate. Clause after clause was carried, undiscussed, under the closure, full of complicated provisions, the working of which very few of the rank and file in Parliament even pretended to understand. For judicial examination in debate, reflecting the careful conclusions of the House of Commons, was substituted the opinion of the ministers in charge of the bill, alike as to the powers it gave and the way those powers were likely to be used. Just as the Insurance Act had left all sorts of obscure questions to be settled by the commissioners, so the Home Rule bill left some of the thorniest problems of the financial relations with Ireland to be solved by the proposed Joint Exchequer Board, an entirely new official body, whose real status was highly questionable; and clause 22 providing for this, with the remaining financial clauses, 23, 24 and 25, were duly guillotined on Nov. 27. Eventually, under the guillotine, the bill passed its third reading on Jan. 17 1913. The committee stage had ended on Dec. 12, clauses 26-48 and the final schedules having been carried since Dec. 2 by the operation of the guillotine without any concession to Unionist criticisms. The committee stage had lasted altogether 36 days, including the 25 provided under the time-table; two clauses (1 and 37) had been fully discussed, and 22 partly discussed, while 24 had received no discussion at all.

For the Welsh Church bill the time-table resolution had similarly been carried on Nov. 28, at the end of an all-night sitting, though the Government agreed to give 16 Welsh Bill Guiltlines. days, instead of the 14 originally proposed, to the committee stage, which began on Dec. 5; and by Christmas 1912 this bill too was well on its way through the House of Commons. The discussions were marked throughout by much bitterness of feeling on the part of the defenders of the Church, among whom Lord Robert Cecil was specially prominent, but they were notable also for some important expressions of the desire of Liberal churchmen to make the disendowment proposals less harsh than what the Welsh Non-conformists considered to be in accordance with their rightful demands. A concession was made on clause 8, the Government accepting (Dec. 18) amendments proposed by Sir Ryland Adkins and Mr. Atherley Jones (both Liberals), by which, much to the disgust of the Welsh members, the Church would retain possession of the Queen Anne's Bounty funds and property. On another amendment, proposed by Mr. Ormsby Gore (Conservative), for keeping all the glebe as church property, the Government majority fell (Dec. 19) to 55, the figures being 277 to 222; and clause 8 was only carried by 284 to 221. The fact that the majorities in both these cases were smaller than the number of Irish Nationalists voting with the Government showed that there was a good deal of sympathy with the opposition among some sections of Liberals.

The actual proceedings in the House of Commons were being followed, however, with marked apathy in the country. Everybody felt that the real struggle had to come Revival of Liberal Guiltlines. during 1913. During the past month the critical state of European affairs monopolized public interest; and the party conflict took a secondary place when larger issues were at stake. Mr. Asquith and Sir Edward Grey, by common consent, were making British influence a powerful factor for peace in the settlement of the Balkan crisis. The administration was strengthened for the moment simply by the fact that it represented the whole nation in the councils of Europe. Meanwhile trade was booming, and in some other respects also the position of the Government was more favourable than it had seemed likely to be a few months earlier. At Bolton, when there was a by-election on Nov. 23, the Liberal candidate surprised his own party by retaining the seat with only a slightly diminished majority. Moreover, the Unionists were again in the throes of further discussions over their Tariff Reform policy. Since Mr. Bonar Law had become the Unionist leader little had been heard of any way

ing as to the principle of low taxes on foreign wheat and other foodstuffs so as to give a preference to colonial imports. But the question of going to another election at all on a programme including food-taxes was now raised again on what started purely as a side issue. It was thought by the leaders of the party that the time had come when an explicit declaration should be made that Mr. Balfour's proposal, before the general election of Dec. 1910, to submit the first Tariff Reform Budget after the Unionists returned to office to a referendum, was no longer the party policy; and Lord Lansdowne accordingly made a statement to that effect at the Albert Hall on Nov. 14 1912. No sooner had it been made than an agitation arose in certain Unionist quarters, especially in Lancs., where it was contended that harm would be done to their electoral prospects by dropping the proposal; and the cry was taken up in circles where the food-taxes had always been disliked, with the result that pressure was put on Mr. Bonar Law to make a definite pronouncement on the whole scheme of Imperial Preference. This he did at Ashton-under-Lyne on Dec. 16, but without the effect that was presumably intended.

A large part of Mr. Bonar Law's speech was devoted to combating the claims of the Radical party that they were the *Mr. Law's* peculiar friends of the working classes; on the contrary he insisted that the party now in power were *Ashton* occupied mainly in work of destruction, and that *Speech* the real social needs of the community could only be met by a Unionist government. He repudiated the allegation that Tariff Reform was simply old-fashioned Protectionism. It was not proposed to bolster up industries which were not naturally suited to the country, or to enable manufacturers to secure an artificial monopoly. Tariff Reform involved the imposition of duties smaller than in any other country, and its object was to give British workmen a preference in the home market over their foreign competitors. Similarly, the object of Imperial Preference was to unite the Empire on lines of trade, and to secure for the United Kingdom the largest possible advantage in the British overseas markets. It was in connexion simply with colonial preference that food duties were included in the Unionist programme, and he adhered to that policy in spite of all the misrepresentations to which it lent itself. But here he announced a new departure:—

"If our countrymen entrust us with power, we do not intend to impose food duties. What we intend to do is to call a conference of the colonies to consider the whole question of preferential trade, and the question whether or not food duties will be imposed will not arise until those negotiations are completed. . . . Unless the colonies regard them as essential for preference the food duties will not be imposed. All that we ask is that our countrymen should give us authority to enter into that negotiation. If the colonies do think them necessary, then I for one do not believe that the people of this country would not be ready to make that readjustment which is necessary to effect the purpose."

As regards the referendum, Mr. Law repeated Lord Lansdowne's declaration, and justified it on the ground that a pledge to submit the result of the negotiations with the colonies to a referendum would not be fair to the colonies.

Next morning this speech had a "mixed" reception both in the Unionist press and in the party. In some quarters strong objection was taken to making the taxation of the United Kingdom appear in any shape to depend on the decision of the colonies; the responsibility must be with the electors of the United Kingdom. In Lancs. and Yorks., and also in Ireland and Scotland, some important Unionist papers openly mutinied against the abandonment of the referendum. Uncertainty as to what Mr. Law really meant—an unusual thing in his case—led to a revival, in the clubs and in the House of Commons, as well as in the press, of the same sort of expression of hostile sectional views that had made Mr. Balfour's leadership so difficult between 1903 and 1906. There were "alarms and excursions" for several days. As consideration became cooler, it was recognized, however, that nobody wanted to do anything that was not in the interest of a united party. Mr. F. E. Smith,

speaking at Dudley on Dec. 20, declared that the whole Unionist front bench in the House of Commons adopted the views expressed by Mr. Law, and that he had never meant that the decision as to food duties would be left to the colonies; all that he meant was that the decision must depend on what the colonies wanted. Mr. Austen Chamberlain also wrote a letter to a correspondent on Dec. 23, agreeing with Mr. Bonar Law.<sup>1</sup>

While this lively interlude was providing sport for the Free Trade party, the penultimate act of another drama, of more direct import to Liberalism, was also drawing to its close. On Dec. 10 the result of the poll was published which had been taken among the medical profession, as to whether they would accept Mr. Lloyd George's latest terms for ordinary medical service under the Insurance Act. Out of a total vote of 13,731, 11,309 were for rejection. On Dec. 20 the representative meeting of the British Medical Association was held, and by 187 votes to 21 a resolution was passed rejecting the Government proposal and advising the profession to decline service under the Act. In the previous Feb. practically the whole profession—at all events 27,460 doctors—had signed an undertaking to stand together by the policy to be decided upon by the British Medical Association, and if they held to their pledge this meant a complete breakdown in the provisions of the National Insurance Act for medical benefit, which were to become operative on Jan. 15 1913. On the other hand, a scheme for an alternative policy was coupled with this flat refusal of Mr. Lloyd George's own proposals. It was recommended that the profession should express its willingness to treat insured persons, under arrangements to be made between local committees of doctors and the insured or their representatives (i.e. the approved societies) for a minimum capitation rate of 8s. 6d., inclusive of drugs, or a minimum fee of 2s. 6d. a visit, on condition that each insured person should have free choice of doctor and that the doctor should consent to act. Under this plan the doctors would not be dictated to by the lay insurance committees, but the financial terms would be practically the same that Mr. Lloyd George had last offered. It was promptly announced that the Government could not fall in with this proposal, which would involve handing over public money without public control; and the question now was whether there would be sufficient breaking-away from the pledges given to the British Medical Association for the insurance committees to be able to secure their panels of doctors in accordance with the regulations under the Act. Only about half of the 27,000 doctors who had ranged themselves with the Association in Feb. had actually taken the trouble to go to the poll in Dec., and though this was generally believed not to indicate in itself any corresponding failure in the solidarity of the profession, there were now signs of a good deal of independent action in certain localities, and notably in Scotland. Already in Nov. a few doctors who thought it a public duty to fall in with the Government scheme had started a new organization in opposition to the British Medical Association, called the National Insurance Practitioners Association; and its influence, backed by Government support, was being exerted in the same direction. On Jan. 2 1912 Mr. Lloyd George, addressing the Advisory Committee, took a sanguine view of this situation, and declared that some 8,000 doctors were available. Nevertheless the strike now proclaimed against the Insurance Act by the recognized leaders of the medical profession was a very awkward fact for the Liberal party.

The year thus ended with the promise of a full crop of domestic political difficulties to be harvested in 1913. (H. C.)

L. FROM JAN. 1913 TO JULY 1914.

The political difficulties bequeathed by 1912 to 1913 were still unsolved 15 months later, at the outbreak of the World War in Aug. 1914. The medical opposition to the National Insurance Act eventually, as the result of a memorial from the rank of the Unionist M.P.'s, Mr. Bonar Law, on Jan. 14 1913, stated in a letter that he and Lord Lansdowne, while remaining leaders of the party, were willing to agree that food duties should not be imposed without the approval of the electorate at a subsequent general election.

The Doctors and the Insurance Act.

since Act did indeed melt rapidly away in 1913. In spite of a vehement professional meeting of protest on Jan. 7, the British Medical Association found itself forced by the independent action of doctors in all parts of the country to release its members from their pledge not to serve on the panels; and, though the Act remained for long unpopular, medical benefit was brought generally into operation, as arranged, on Jan. 15. At first the panel doctors were greatly overworked, and there were many laches in administration. To obviate these, and to meet objections raised by the great Friendly Societies and by the trade unions, a substantial amending bill, involving a further charge on the State of £20,000 per annum, was introduced and carried by the Government. The Opposition did not fail to point out that this immediate necessity for amendment proved their charge that the provisions of the original Act were hasty and ill-considered; but Mr. Lloyd George was able to claim in Aug. that there were 18,000 doctors and 9,000 chemists working under the Act and prospering through it; that 270,000 workers were receiving sickness benefit, and that 20,000 consumptives—13,000 in sanatoria—had been already treated. In Feb. of the following year he boasted that there were over 20,000 general practitioners on the panels out of 22,500 in Great Britain; that nearly £1,500,000 had been distributed among them, besides £933,000 for drugs and an unalotted balance between doctors and chemists of £310,000.

The internal controversy among the Unionist party about Tariff Reform was also settled, at any rate temporarily, at the beginning of 1913. Mr. Bonar Law's Ashton declaration did not satisfy the opponents of food taxes, who were strongly supported by important organs of the Unionist press, and early in Jan. a memorial was presented to him signed by almost the whole body of Unionist M.P.s, advocating a further modification of the proposed procedure but strongly deprecating any consequential change of leadership. The leaders acceded to their followers' wishes. After stating that the Unionist policy would be not to impose new duties on food, in order to secure the most effective system of preference, until they had been submitted to the people at a general election, Mr. Law added that he and Lord Lansdowne would have preferred that this change of method should be accompanied by a change of leaders, but in deference to the expression of opinion in the memorial they would remain. In a speech at Edinburgh on Jan. 24, Mr. Law claimed that, in spite of the modification, the flag of imperial preference was still flying, and the Unionist policy remained perfectly definite. They would impose a lower tariff than that of any industrial country in manufactured goods; they would give the Dominions the largest preference possible without food duties; and they would try to establish cooperation throughout the Empire in trade as well as in defence. They would work out with the Dominions the best scheme to this end, and put it before the electors for their assent. The solution was welcomed by the bulk of the Unionist party, and was accepted by Mr. Austen Chamberlain, though he said in Dec. that his submission to the conditions laid down at Edinburgh was the bitterest sacrifice he had ever made. There were protests in extreme Tariff Reform circles, but these did not seriously impair the regained unity of the party.

But no solution was found; before the war broke out, of the franchise question, of the grave problems of industrial unrest, or of those involved in the two great measures going forward under the provisions of the Parliament Act—the Welsh Disestablishment bill and the Irish Home Rule bill. The Franchise bill which the Government had introduced was to serve two main purposes: to abolish plural voting, and to afford a means, by way of amendment, of testing the opinion of the House of Commons on women's suffrage. The abolition of plural voting was strongly resented in the City of London, the most famous constituency in the country, as thereby an electorate containing the principal bankers and merchants of the Empire would be transformed into one consisting of a small number of resident caretakers and messengers. But it was the proposal to enlarge the bill by including women's

suffrage in it that proved fatal. On Jan. 27 the Speaker ruled, as a matter of order, that, if any amendments of the kind were inserted, the bill would become a new bill and would therefore have to be withdrawn. The Reform bills of 1832, 1867, and 1884 had been designed to enfranchise new classes of the people; this bill was not, and therefore could not properly be amended in the sense desired by the advocates of women's suffrage. The Government accordingly withdrew the measure, promising, however, to give facilities for a private member's suffrage bill in the next session. This *controversy* was a blow both to the prestige of the Government and to the suffragist cause. Militancy was at once resumed and was rampant throughout the year; Mrs. Pankhurst, the leader of the movement, announced that she would hold nothing sacred except human life.

Shop-windows were smashed; golf links were defaced; telegraph wires were cut; church services and public meetings were interrupted; a woman lost her life in attempting to interfere with the race for the Derby. But arson was the principal weapon of the extremists, and during the year many railway stations, grand stands, boat-houses, pavilions, unoccupied country-houses, and even churches were by them wholly or partially burnt down. Popular feeling, in consequence, ran high against the militants; these meetings in London were broken up and had to be prohibited by the police. A large proportion of the women who were convicted of committing outrages and sent to prison started a hunger-strike. This move was met by forcible feeding—a practice against which public opinion revolted; and for which was substituted, under an Act passed *ad hoc* and nicknamed the "Cat and Mouse" Act, a system of releasing prisoners on licence. The atmosphere produced by these events was not favourable to the Women's Suffrage bill, which was rejected on May 6 by 167 votes to 120, all parties being divided except the Labour members who solidly supported the bill. The "Cat and Mouse" Act proved a failure. The women released under it qualified for prison once more, directly their strength was restored, by committing fresh outrages, and the authorities, who could not let their prisoners die on their hands, resorted again to forcible feeding in spite of the protests of many clergy and humanitarians. Meanwhile the non-militants, who formed the great majority of the supporters of the women's suffrage movement, were not inactive. Under Mrs. Fawcett's leadership they constantly pressed ministers to introduce a Government bill; and they advertised their cause by promoting a pilgrimage of women who perambulated the length and breadth of England at the height of summer in eight separate contingents, uniting at the end in a great demonstration in Hyde Park on July 26. In spite of the efforts of both sections, the Government maintained its neutral position. But it introduced a simple Plural Voting bill in April, with a view to passing it ultimately into law under the Parliament Act. It was carried through Committee in the House of Commons, in spite of Opposition protests, by the "Kangaroo" closure, and was rejected, because it was unaccompanied by a measure of redistribution, on second reading by the House of Lords. There was a repetition of this process in the session of 1912; but, owing to the outbreak of war, the bill was not introduced in 1913, and so failed. A compromise was arranged on another measure, the Temperance (Scotland) bill, to which it had been intended to apply the Parliament Act. In the shape in which the House of Lords passed the bill, it provided for local option on the question of liquor licenses in certain areas in Scotland; the popular vote, however, was postponed until 1920—when, if may be added, the Prohibitionists met with a severe defeat.

Militancy was continued and intensified in the first half of 1914. Outrage so frequently took the form of wanton damage to valuable pictures in the National Gallery, Royal Academy, and other exhibitions; that public galleries had to be closed. Arson was rampant. Bombs were exploded in well-known churches, the coronation chair in Westminster Abbey having a narrow escape from serious injury by this method. An unsuccessful attempt

Unpopular  
and food  
taxes

Franchise  
bill and  
Women's  
Suffrage

Militancy

Plural  
Voting Bill

Rescued  
Millinery  
in 1914



was made to force a way into Buckingham Palace to petition the King in person; and His Majesty was subjected, on several public occasions, to rude interruption. The number of militants actually committing crimes was small, but they had a large number of enthusiastic sympathizers who kept them well supplied with funds. Formal protests and condemnation by the non-militant section of suffragists had no effect on the campaign, which was only terminated by the coming of war.

Although the labour conflicts of 1913 and the first seven months of 1914 were not on the scale of the great strikes of 1912, there was constant unrest, and many signs that serious trouble was brewing. The Labour party in Parliament marked their increasing divergence from the principles accepted by both the historical parties by moving, at the beginning of the session of 1913, an amendment to the Address, which was of course easily defeated, in favour of a general system of nationalization. While there were sporadic strikes in various parts of Great Britain in the autumn and winter of that year, the principal disturbance was in Dublin and the neighbourhood, where, under the leadership of James Larkin, of the Irish Transport-Workers' Union, a series of strikes was organized, which lasted, despite official and other efforts at settlement, from Aug. to the close of the year, and which, during part of that time, brought the trade of the port of Dublin to a standstill. Larkin conducted his campaign with violence, was more than once arrested, was convicted of using seditious language, imprisoned, and then after a fortnight released. At first there was much sympathy from the Trades Union Congress and other representatives of English labour; the Dublin strikers were supplied with funds from England, and there were some half-hearted attempts at sympathetic strikes. But Larkin's revolutionary attitude, which had already antagonized moderate Irish Nationalists, eventually alienated British labour leaders, and left him only the support of the extremists, who held the first Syndicalist congress in Great Britain that autumn and declared in favour of "direct action." Early in 1914 there was great indignation in British labour circles over the deportation by the South African Government of the labour leaders concerned in strike disturbances in Johannesburg. They were received, on their arrival in England, with great demonstrations at the London Opera House and in Hyde Park; and an unsuccessful attempt was made by the Labour party in Parliament to interfere with the discretion of a self-governing Dominion. The irritation caused by this deportation was symptomatic of the general labour unrest, which in the first half of 1914 affected miners, engineers, gas-workers, char-workers, municipal employees, dockers, transport-workers, coal-porters and many other groups of artisans. The absolute refusal to work with a non-unionist had so disorganized the London building trade that a stubborn struggle, which lasted for months, was begun by a general lockout in January. In May the railway servants decided to demand the recognition of their trade union, a 48 hours' week, and an increase of wages by 5s. weekly; and in June they gave a final approval to the "Triple Alliance" of their union with the Miners' Federation and the Transport Workers' Federation. The industrial prospect was dark.

The opening of the year 1913 found Parliament still in session, and engaged in completing the final stages of the Home Rule and Welsh Disestablishment bills. The report stage of the Home Rule bill did not produce any serious amendment except the introduction of proportional representation in the nine proposed Irish constituencies returning three or four members. There was a notable debate on New Year's Day on Sir Edward Carson's motion to exclude the province of Ulster from the operation of the measure. Mr. Asquith, while expressing his readiness to consider additional safeguards, denounced the proposal as a claim by Ulster to veto Home Rule. Mr. Bonar Law solemnly promised support by the Unionist party to Ulster if the bill were forced on her and she resisted. The Government had its normal majority of about 200. The third reading debate on Jan. 15 and 16 did not reveal any new arguments; but Mr. Redmond stated

that the Nationalists accepted the bill as a final settlement. In spite of Unionist predictions of immeasurable calamity, the third reading was carried by 367 to 257. The Lords debated the bill on second reading for four days (Jan. 27, 28, 29 and 30) before rejecting it by 226 to 69. The impossibility of working the scheme in face of the resistance of Ulster was the main ground put forward by the Unionists for rejection. But the most interesting feature of the debate was the strong advocacy by Lord Grey, ex-Governor-General of Canada, of a solution on federal lines—a proposal supported in a striking speech by the Archbishop of York (Dr. Lang). Neither the passing of the bill by the Commons, nor its rejection by the Lords, evoked any serious popular excitement.

Before the Welsh bill left the Commons its provisions were further mitigated in some slight degree. An amendment was adopted, favoured by Liberal churchmen, giving the Church body the option of commutating the life interests of the clergy on a 2% basis. There was a strong attempt made by the Unionists to confine the purposes to which the consecrated Church property should be applied to the advancement of the Christian religion by grants to Nonconformist churches. But, as the spokesman of the Nonconformists repudiated the idea of secular endowment, the amendment was rejected by 273 to 202, though the Government agreed to limitation to charitable and eleemosynary purposes. The third reading was carried on Feb. 3 by the usual Government majority, after an eloquent exposition by Mr. Lloyd George of the sentiments of the Welsh people. The measure was debated on second reading by the Lords on Feb. 11, 12 and 13, and rejected by 252 to 51. Sixteen bishops voted in the majority; those of Hereford (Percival) and Oxford (Gore) in the minority.

The rejection of these two bills by the Lords, and the determination of ministers and of their majority in the Commons to override the veto of the Upper House through the use of the powers conferred by the Parliament Act, were the considerations governing the whole course of politics down to the outbreak of war. The main purpose of the sessions of 1913 and 1914 was to carry the two measures through the Commons a second and third time, so as to qualify them for passage into law in spite of the Lords. Feeling was naturally exacerbated by so high-handed a policy; especially as both bills, though apparently supported by the bulk of opinion in Ireland and Wales respectively, were strongly resisted by a majority of the parliamentary representatives of England, the predominant partner in each case. A recess of only three days separated the prorogation of the prolonged session of 1913 from the opening of the session of 1914 on March 1. The Opposition immediately joined issue on the Address by an amendment which asserted that the Irish and Welsh bills ought not to be proceeded with while the constitution of Parliament was still incomplete and without reference to the electors; but they were defeated by 262 to 169. The two controversial bills were carried for a second time through the Commons by the normal Government majority. As the Opposition resisted both measures in principle, no use was made of the limited opportunity for "suggestion" of amendments in Committee permitted by the Parliament Act. When the two bills came up to the House of Lords they were both met with identical resolutions that "this House declines to proceed with the consideration of the bill until it has been submitted to the judgment of the country." This was carried in the case of the Irish bill by 302 to 64; in that of the Welsh bill by 242 to 88. Thus the second stage for both under the Parliament Act was duly completed.

In all the debates on the Home Rule bill the Unionist leaders dwelt with insistence on the serious prospect before the country. We were "on the verge of a great national tragedy," said Mr. Balfour. The Liberals were crying peace where there was no peace, said Sir Edward Carson; Ulster had behind her in her resistance the whole force of the Conservative and Unionist party. The Liberals and Nationalists, however, still maintained that the Ulster attitude

Labour Unrest

Welsh Bill rejected by Lords

Second Stage of the 1914 Bill

Home Rule Bill rejected by the Lords

The Motion of Ulster

was largely bluff. Mr. Redmond, on behalf of his party, disclaimed any desire to establish ascendancy, and avowed that Ulster would not be attacked. But the Unionists relied more on speeches in the great towns, and on events in Ulster than on Parliament for the enlightenment of the country. Immediately after the division on the second reading, in June, Sir Edward Carson started on a political tour in Great Britain, making eloquent speeches in Glasgow, Edinburgh, Norwich, and Bristol—a demonstration which Mr. Redmond and his friends endeavoured to neutralize by following in the Ulster leader's footsteps. In July Sir Edward Carson spent several weeks in organization and speech-making in Belfast and the neighbourhood. He foreshadowed the establishment of a Provisional Government for Ulster; and assured his hearers that the Cabinet could not rely upon the army in forcing Home Rule upon them. Volunteers continued to drill, and provided themselves with the usual accompaniments of a modern army. More definite steps were taken in the autumn. On Sept. 25 the Ulster Unionist Council formally organized itself into a Provisional Government, with a central authority whose chairman was Sir Edward Carson, and a guarantee fund intended to reach £1,200,000, to which the leaders contributed £25,000. He formally reviewed the Volunteers, who then numbered 80,000 and increased to nearly 100,000 by the winter. On Nov. 9 there was a great demonstration in Belfast in favour of his policy by Ulster men of business, presided over by the president of the Belfast Chamber of Commerce. And on the 26th there was an enthusiastic meeting in his support in Dublin, where Mr. Law repeated his pledges to Ulster.

The Liberals resorted to these proceedings with jeers at "King Carson," and suggestions, which the Cabinet were too wise to adopt, for his arrest. But many of them began to realize that there was a substantial difficulty in Ulster which could not be any longer ignored. Suggestions for a conference to arrange a compromise were thrown out in the Lords debate in July, and became more definite as the year drew towards a close. Mr. O'Brien, for the Independent Nationalists, pleaded for some such course; Lord Loreburn, the Liberal ex-Lord Chancellor, proposed it in *The Times* of Sept. 22; Lord Grey urged the advantages of a federal solution; and on Oct. 9, Mr. Churchill, an important member of the Cabinet, advocated at Dundee a solution by agreement. Though Mr. Redmond, on Oct. 22, refused to contemplate anything beyond an increase in the safeguards for the minority, Mr. Asquith, in his annual address to his constituents at Ladybank on Oct. 29, said that the Government were prepared to consider proposals within the scope of the bill; that they were anxious for a settlement by consent, not through a conference, but through a free and frank exchange of views. Two days later Sir Edward Grey, at Berwick, suggested that there might be a Home Rule for Ulster within Home Rule for Ireland. Mr. Law replied at Walland on Oct. 29 that he would consider any proposals with a real desire to find a solution, and Sir Edward Carson, who was present, expressed his agreement, but the offer must be consistent with the Covenant. A fortnight later, at Norwich, Mr. Law said it was the duty of the Government to submit their proposals to the judgment of the people either at a general election, or by a referendum. Mr. Redmond, speaking at Newcastle-on-Tyne next day, described the Unionists as trying to intimidate the people of England. Still he expressed a preference for a settlement by consent, but it must be based on national self-government for Ireland. Mr. Lloyd George on Nov. 9 attacked Unionist demonstrations against Home Rule as a red herring distracting his campaign for social reforms. There was much speaking on both sides during the last weeks of the year, but apparently no advance towards an agreement. Mr. Law said the sands were running out and nothing had been done, but Sir Edward Grey replied that these were still some months to spare. In the beginning of the new year Lord Curzon intimated at Manchester that the conversations between leaders had had no result. Sir Edward Carson went to Belfast and advised "peace but preparation," and Mr. Redmond assured his constituents at Waterford that the bill

would this year automatically become law. The Unionists were strengthened in their resistance by some gains in by-elections during 1913 and early in 1914, but perhaps the most striking feature in the polls was the increasing support given to Labour at the expense of the Liberals.

It was in these conditions of doubt and apprehension that Parliament reassembled on Feb. 10, 1914. The King's speech, while admitting that efforts at solution had so far failed, expressed a hope that they would yet succeed. Mr. Asquith laid stress upon these words in the debate on the Address. Sir Edward Carson said that, if the Government were in earnest, there must be an amending bill—a suggestion which Mr. Redmond ridiculed. No move was, however, made by the Government in the next week or two; and the organization of public opinion in England in support of Ulster was rapidly proceeding with. A British Covenant, similar to the Ulster Covenant, was promulgated on March 3, headed by the signatures of influential men, not closely identified with political party, such as Lord Roberts, Lord Halifax, Lord Milner, Prof. Dicey, Dean Wace, and Mr. Rudyard Kipling. A Woman's Covenant followed; and both documents were eagerly signed, an appreciable proportion of the signatures being professing Liberals. On March 9 Mr. Asquith, in moving for the third and last time the second reading of the Home Rule bill, announced the projected concessions. The Government would propose that any county in Ulster, including the county boroughs of Belfast and Londonderry, might vote itself out of the jurisdiction of the Irish Parliament for a term of six years, after which it would automatically come within that jurisdiction. The Prime Minister pointed out that, under the Parliament Act, there would necessarily be two general elections in Great Britain before the six years expired. This scheme of provisional exclusion entirely failed to satisfy either the Opposition or Ulster. Mr. Law said that, if this was the last word of the Government, the position was very grave; Ulster was asked to destroy her future; Mr. Redmond insisted that this was the extreme limit of concession; and the Independent Nationalists protested vehemently against partition. Sir Edward Carson took note of the gain involved in admitting the principle of exclusion, but said emphatically: "We don't want sentence of death with a stay of execution for six years." The situation became sensibly graver when Mr. Churchill at Bradford, on March 14, said that the Prime Minister's offer appeared to him to be final, approached the Unionists and Ulster for not being satisfied with it, and maintained that, in the event of violence, the larger issue, between parliamentary government and armed force, once fought out at Marston Moor, would become dominant. If there was any attempt in action to subvert parliamentary government, there was no lawful measure from which the Cabinet would shrink. They had sent out soldiers during the railway strike, with Unionist approval. If the British civil and parliamentary systems were to be brought to the challenge of force, he would only say "Let us go forward together and put these grave matters to the proof." This utterance, which was endorsed a few days later by Mr. Lloyd George, and the refusal of the Prime Minister to give details of his proposals unless the general principle were adopted, led to an Opposition motion of censure on March 19. In the debate Mr. Law made a formal offer: if the new suggestions were put into the Home Rule bill and accepted by the country on a referendum, he had Lord Lansdowne's authority to say that, so far as his influence in the House of Lords went, he would not oppose the will of the people. This Mr. Asquith would not accept. Sir Edward Carson then left the House, amid a great Unionist demonstration, and accompanied by eight Irish Unionist members, proceeded to Ulster.

An explosion in some form seemed to be imminent. Mr. Law had said in the censure debate that, in a case merely of disorder, the army would and ought to obey; if it were a question of civil war, "soldiers are citizens like the rest of us." This was speedily proved. It was determined to protect certain military stores in the N. of Ireland, from possible raids by Ulster Volunteers, and a considerable

force was ordered on March 20 to move N. from Dublin with naval support. To the officers on duty at the Curragh this appeared to be the beginning of a movement to coerce Ulster by the army—an impression which was confirmed by certain questions asked them and alternatives put before them; and Gen. Sir Hubert Gough, in command of the cavalry brigade, with many of his subordinate officers, preferred to accept dismissal rather than initiate active military operations against Ulster. They were informed by the General Officer Commanding that it was merely a measure of precaution, and the senior officers concerned were ordered to report themselves at the War Office. There, in answer to a letter in which Gen. Gough asked the Adjutant-General to make clear whether, if the Home Rule bill became law, the officers "could be called upon to enforce it in Ulster under the expression of maintaining law and order," the following minute (dated March 23 1914) was written in reply, initiated by the Secretary of State, the Chief of the General Staff (Sir John French), and the Adjutant-General:—

"You are authorized by the Army Council to inform the officers of the 3rd Cavalry Brigade, that the Army Council are satisfied that the incident which has arisen in regard to their resignations has been due to a misunderstanding. It is the duty of all soldiers to obey lawful commands given to them through the proper channel by the Army Council, either for the protection of public property and the support of the civil power in the event of disturbances or for the protection of the lives and property of the inhabitants. This is the only point it was intended to be put to the officers in the questions of the General Officer Commanding, and the Army Council have been glad to learn from you that there never has been and never will be in the Brigade any question of disobeying such lawful orders. His Majesty's Government must retain their right to use all the forces of the Crown in Ireland, or elsewhere, to maintain law and order and to support the civil power in the ordinary execution of its duty. But they have no intention whatever of taking advantage of this right to crush political opposition to the policy or principles of the Home Rule bill.

On receiving this document Gen. Gough asked Sir John French if it meant that he would not be called on to order his brigade to assist in coercing Ulster to submit to Home Rule, and Sir John French wrote across it, "I should read it so." The precautionary movements were carried out and all orders were duly obeyed.

These facts came out gradually in the week following Sir Edward Carson's removal from Westminster to Belfast, and there were many scenes and much recrimination in the House of Commons. On hearing the news of the officers' action, the Unionists asserted that there was obviously a plot to provoke Ulster, which the reluctance of the officers had defeated; the Prime Minister replied that the movement of troops was purely protective, and that, if officers and soldiers were to discriminate between the validity of different laws, the fabric of society would crumble; while the Labour party claimed that, as any option given to officers must logically be extended to men, the army could no longer be used in labour troubles. When the minute of the Army Council was published the Liberals were dismayed, while the Unionists accepted it as making the coercion of Ulster impossible. Ministers explained to their bewildered followers that the first three paragraphs were settled by the Cabinet, but that the last two, which, in connexion with Gen. Gough's letter, seemed to constitute a bargain with the officers in regard to a hypothetical contingency, had been added by the War Secretary without Cabinet authority. Amid prolonged Liberal and Labour cheers Mr. Asquith repudiated any bargain of the kind, and caused a new army order to be issued, under the heading "Discipline," as follows:—

1. No officer or soldier should in future be questioned by his superior officer as to the attitude he will adopt or as to his action in the event of his being required to obey orders dependent on future or hypothetical contingencies.

2. An officer or soldier is forbidden in future to ask for assurances as to orders which he may be required to obey.

3. In particular it is the duty of every officer and soldier to obey all lawful commands given to them through the proper channel, either for the safeguarding of public property, or the support of the civil power in the ordinary execution of its duty, or for the protection of the lives and property of the inhabitants in the case of disturbance of the peace.

Ministers did not seem to be prepared for this national assault of these proceedings, the resignation of the three members of the Army Council who had initiated the minute of March 23—Col Seely (the War Minister), Sir John French, and Sir Spencer Ewart. The Prime Minister endeavoured to persuade all three to reconsider their determination, as these were, in his view, no difference of opinion amongst them; but, having failed, he assumed himself the office of Secretary of State for War in addition to that of First Lord of the Treasury. In an address to his constituents on seeking reflection, he illustrated the spirit in which he proposed to act by quoting the words of Chatham: "The army will hear nothing of politics from me, and in return I expect to hear nothing of politics from the army." The Unionists noted with satisfaction that both Col. Seely himself, and Lord Morley who assisted in drafting the peccant paragraphs, stated that they did not see that these differed in spirit and substance from the three preceding paragraphs. The conclusion seemed to be that the Government repudiated the intention to make use of the army "to crush political opposition to the policy or principles of the Home Rule bill." A gigantic demonstration of protest against the coercion of Ulster was held on April 4 in Hyde Park; there were 22 separate processions and 14 platforms, and men of the public eminence of Mr. Balfour, Sir Edward Carson, and Lord Milner attended and spoke. The gravity of the situation led to many expressions in the Home Rule debate of a desire for an agreed settlement. Sir Edward Carson said there was only one policy possible: "Leave Ulster out until you have won her consent to come in." But ministers would not advance beyond their previous proposals, and the second reading was carried by 80 votes, as compared with majorities of 110 and 100 in the previous year. There was a similar decline in the majority for the second reading of the Welsh bill.

Meanwhile events were moving in Ireland. Easter week saw a series of reviews by Sir Edward Carson of large bodies of Ulster Volunteers; and on the night of April 24-25 some 35,000 rifles and 3,000,000 cartridges were landed at Larne and distributed throughout the Protestant north. This successful feat of gun-running, and the publication of papers with regard to the alleged military "plot," produced heated debates in Parliament, followed, however, by further private negotiations between leaders. Before the third reading of the Home Rule bill, the Prime Minister gave notice that the Government would introduce—in the House of Lords—an Amending Bill, which might pass simultaneously with the Home Rule bill. It was only, however, after a scene of disorder in the House of Commons that he disclosed its nature: it would give effect to the terms of agreement if arrived at, and, if not, to the proposals outlined on March 9. This was far from satisfying the Opposition, and the third reading of the Home Rule bill was only carried by 351 to 274, that of the Welsh bill having been secured by 328 to 257.

The two bills left the Commons before the Whitstable recess, which was spent by Sir Edward Carson in Ulster in making "preparations for the final scene." While there was every sign of resolute determination about Ulster and her Volunteers, Nationalist Ireland had retreated by enrolling Volunteers of her own, who were estimated to exceed 100,000 men. This force was started independently of the official Nationalists, and it was only with some difficulty that Mr. Redmond obtained control by the end of June. There were thus two armed bodies of many thousands of men facing each other in Ireland in a state of what Lord Milner called "smouldering war." In these alarming circumstances the Amending bill, introduced in the Lords on June 28, which merely offered option of exclusion by counties for six years, seemed inadequate. It was read a second time in the beginning of July, after a prolonged debate, in the course of which Lord Roberts warned the Government that any attempt to use the military force of the nation to coerce Ulster would break and ruin the army. In committee the Unionist majority transformed the measure by amendments

Mr. Asquith as Secretary.

Detained within of Ulster.

Approach of Civil War.

permanently excluding the whole province of Ulster, Nationalist counties no less than Unionist, from the operation of the Home Rule Bill. It was certain that the Liberal and Nationalist majority in the Commons would indignantly reject this solution. At the same time the urgency of the Ulster problem was again enforced by enormous demonstrations on the Boyne anniversary, emphasising Sir Edward Carson's words: "Give us a clear-cut or come and fight us."

The Amending bill was to be taken in the Commons on Monday July 30; but the King and the wiser heads in the Cabinet were determined to make a further effort for peace; and on that morning *The Times* announced that the King had issued invitations to a conference on the Ulster question at Buckingham Palace, consisting of

two members each from the Government, the Opposition, the Nationalists and the Ulster Covenanters. Moderate men in all parties hailed the announcement with relief; but keen partisans were suspicious and critical. The conference met on Tuesday under the chairmanship of the Speaker. The Government were represented by Mr. Asquith and Mr. Lloyd George; the Opposition by Lord Lansdowne and Mr. Bonar Law; the Nationalists by Mr. Redmond and Mr. Dillon; and the Ulstermen by Sir Edward Carson and Capt. Craig. The King opened the proceedings in a brief but weighty speech. He said:

"My intervention at this moment may be regarded as a new departure. But the exceptional circumstances under which you are brought together justify my action. For months we have watched with deep misgivings the course of events in Ireland. The trend has been surely and steadily towards an appeal to force, and to-day the cry of civil war is on the lips of the most responsible and sober-minded of my people."

His Majesty urged on the conference "a spirit of generous compromise," reminded them that the time was short, and expressed his confidence that they would be patient, earnest and conciliatory. In spite of a considerable display of these qualities, the conference failed. The members met on four days, from Tuesday to Friday, and at the close the Speaker announced that they had been unable to agree, either in principle or in detail, on the area to be excluded from the operation of the Home Rule Bill. It was understood that the deadlock arose over the question of the exclusion of Fermanagh and Tyrone, both of them counties greatly divided in political opinion. The position seemed to be desperate, and passions were once more fiercely excited by a fatal affray in Dublin on the following Sunday between British soldiers and the populace—an affray which followed on a successful gun-running on a considerable scale by the National Volunteers. The Amending bill was put down for July 30, and a great Liberal meeting in the London Opera House on the previous day urged the Government to go forward with their programme. But already the international crisis precipitated by Austria's attack on Serbia had become too serious to admit of the continuance of domestic strife. The Amending bill was indefinitely postponed, and civil war was averted by a gigantic European conflict.

The bitterness introduced into politics by the Parliament Act led, during the last years of peace, to frequent rumours and

accusations of irregular if not corrupt dealings by individual ministers in regard, now to silver, now to *The Marconi* wireless, now to oil, now to wireless telegraphy. Only, however, in one instance did there appear to be any foundation for the suggestions of improper action. In April 1912, after the Postmaster-General had accepted a tender for the erection of wireless stations by the Marconi Co., the Attorney-General (Sir Rufus Isaacs, afterwards Lord Reading) bought 10,000 shares in the American Marconi Co., a separate company which, it was contended, did not benefit by the contract, and sold 1,000 each to two friends in the Government—the Chancellor of the Exchequer (Mr. Lloyd George) and the Chief Whip (Lord Murray of Elibank). Some of these shares were resold by their purchasers in the next few days at a profit, but the total net result of the transaction after a year was a loss. The advice to purchase had been given to Sir Rufus by his brother Mr. Godfrey Isaacs, managing director of the American company, and also of the English company. These facts were not told

to the House of Commons when in the previous autumn the Marconi contract was discussed and a committee was appointed to inquire into it. They only came out in March 1913 during the trial of an action for libel against a French newspaper which had given currency to the rumours of corruption that were rife throughout the winter. Thereupon the Attorney-General and the Chancellor of the Exchequer appeared before the committee and explained what they had done. Lord Murray, who had bought further shares in the company on behalf of the Liberal party fund, was abroad. The committee found that the gross charges of corruption were unfounded, but could not agree upon a united report. The majority, consisting of Liberal, Labour, and Nationalist members, awarded no blame to any one except those who circulated the charges of corruption, thereby setting aside their Liberal chairman's draft report, which concluded that ministers had been ill-advised both in their purchase of shares and in their delay in disclosing the facts. The minority, consisting of Unionist members only, found that ministers had acted with grave impropriety. In the debate which followed in the House of Commons on June 18 and 19, both the Attorney-General and the Chancellor of the Exchequer, while protesting their good faith throughout the transaction, admitted that the original purchase was indiscreet, and that the delay in disclosure was a mistake of judgment. After a heated discussion, during which the Unionists vainly endeavoured to secure the passing of some amendment expressing the regret of Parliament for what ministers admitted to be indiscretions, a motion was carried by 346 to 268 accepting the two ministers' statements and reprobating the charges of corruption. Public opinion was more severe than Parliament. It was shocked that important ministers, and especially the guardian of the Treasury, should show themselves so wanting in delicacy and prudence in pecuniary matters. Subsequently in the House of Lords Lord Murray admitted that his action had not been wise or correct, but a committee of that House unanimously found that he had done nothing that reflected on his personal honour.

Mr. Lloyd George at once endeavoured to divert attention from his own indiscretions to the shortcomings of the landlords. What humbug it was for Conservatives, he said, in a speech on July 1 at a luncheon given to himself and *The Land Campaign*, the Attorney-General at the National Liberal Club, to set up an ideal standard for Liberal ministers, when it was notorious that parliaments of landlords in the past had been guided in their legislation by their private interests! The Radical land campaign, started in the previous year, was pushed on, and the subject formed the staple of Mr. Lloyd George's numerous speeches in the country in the autumn of 1913. The Unionists countered the movement by a programme of their own (explained by Lord Lansdowne at Matlock on June 25); which involved the encouragement of small ownership, and the provision of advances by the State to assist the building of cottages and the purchase by tenants of their holdings. At Swindon, on Oct. 22, Mr. Lloyd George announced the ministerial scheme. The Government proposed to set up a Ministry of Lands to take over the functions of the Board of Agriculture, together with registration of title, settled estates, and land valuation—in short to have a general supervision of land and of all dealings with it of whatever kind. Commissioners, having a judicial character, would be appointed, who would be given large compulsory powers in respect of rent, eviction, compensation for improvements, and wages. Tenants would be protected against damage by game. The new ministry would have power to acquire at a reasonable price all waste, derelict, and neglected lands, and to afforest, reclaim, equip, and cultivate them. Housing and cheap transit were also to be provided. While Unionists denounced the extravagance of the scheme, and the "horde of officials" with despotic powers which it proposed to set up, they did not take it very seriously. The event proved them to be right. But Mr. Lloyd George took advantage of his budget for the next year, 1914, to advance his programme of social reform in other ways. He made provision for an extended series of grants to local authorities

III. THE WAR PERIOD

for various sanitary and educational purposes; and he largely increased the sum allocated to national insurance. In order to obtain the necessary funds he proposed to establish a national system of valuation for local taxation, separating site from improvement values; he increased the income tax and super-tax, and took a million from the sinking fund. The proposals, though welcomed by Radicals and Labour men, were not popular with many of his own party; and he had to give up an extra penny on the income tax, and postpone the operation of most of his increased grants for a year; and even so, he only escaped defeat on an Opposition amendment by 303 to 265 votes.

During 1913 and the first seven months of 1914 the King and Queen strengthened their hold on the loyalty of their subjects by popular progresses through the Potteries in April, through Lancs. in July 1913, through the Midlands in June, and through the Lowlands of Scotland in July 1914. They also took the occasion of the marriage of their cousin Prince Ernest Augustus of Cumberland to the Kaiser's daughter to pay a courteous visit in May 1913 to Berlin, where they were courteously received. Of more political importance was the State visit of President Poincaré to London, in the following June, as the King's guest. The cordiality of the official welcome was reflected in the enthusiasm of the people in the streets. In April 1914, the King and Queen, accompanied by the Foreign Minister, paid a return visit to Paris, where they were welcomed with similar enthusiasm by President and people. It was felt in both countries that by these mutual visits the system of friendly co-operation between France and England had received a fresh ratification.

Uneasiness as to the national defences in view of the naval preparations and restless diplomacy of Germany gave a considerable impetus during 1913 to Lord Roberts' campaign for universal military service. In spite of his advanced age he addressed great meetings in large provincial towns—at Bristol in Feb., at Wolverhampton in March, at Leeds in April, and at Glasgow in May—being everywhere received with respect and even enthusiasm. But no party, as a party, was prepared to take up his cause, which received little support from the organized workers; and the Government, by the mouth of Col. Seely, the War Minister, denounced compulsory service as "a political and military disaster." They pinned their faith to the Territorial Force, which Lord Haldane had created. The reluctance of many patriotic men to aid Lord Roberts' movement was due to a fear lest compulsory service should divert effort and money from the navy, the principal defensive force of Great Britain. In introducing the navy estimates for 1913, which involved an increase of over a million, Mr. Churchill, the First Lord of the Admiralty, threw out a suggestion that the Powers who were building ships in competition with each other might all take "a naval holiday" for a year; but the idea met with no response.

In spite of this lack of response, the Chancellor of the Exchequer, in an interview published Jan. 1 1914, called loudly for a reconsideration of the expenditure on armaments. A large section of the Liberal party, whose spokesman was Sir John Brunner, chairman of the National Liberal Federation, strongly supported Mr. Lloyd George. But neither in the Cabinet, nor with the nation at large, did this view prevail. Sir Edward Grey said at Manchester on Feb. 3, that to reduce the British naval programme would be staking too much on a gambling chance. The navy estimates introduced in March by Mr. Winston Churchill were the largest on record, amounting to £51,550,000; and yet they were attacked by Lord Charles Beresford and by the Unionists generally, with considerable public support, as insufficient. On the army estimates, which also showed a slight increase, Col. Seely declared that the British army was much better trained and was much more formidable as a fighting machine than any continental army, and that the Expeditionary Force was absolutely ready. The power and readiness of the fleet were shown by a great review and test mobilization, on a scale never seen before, at Spithead in the third week of July.

The murder of the Archduke Francis Ferdinand at Sarajevo on June 28 horrified public opinion in Great Britain, and led to the expression, in Parliament and elsewhere, of much sympathy for the aged Emperor Francis Joseph. But comparatively few Englishmen realized that the crisis might start a general conflagration in Europe; and the weeks which elapsed before Austria made any overt move encouraged the belief that the effects would be isolated and localized. Even the drastic and peremptory ultimatum addressed by Austria to Serbia on July 23 failed to impress the public with a due sense of its gravity, absorbed as they were in the Buckingham Palace Conference of July 21-4, in the Dublin shooting affray of July 26, and in the apparent imminence of civil war in Ireland. It was only in the very last days of July that Austria's rejection of Serbia's conciliatory reply and her immediate declaration of war, followed rapidly by the Russian and German mobilizations, and by the evidence of French resolve to ally to France's ally Russia, aroused the British people to the fact that a great European war was impending. Even then the general expectation was that Great Britain would not be involved in it. On July 27 Sir Edward Grey gave Parliament an account of his anxious and earnest endeavours to bring the Powers together and avert hostilities. On July 30 the Prime Minister announced that the Government were doing their best to "circumscribe the area of possible conflict." At last on July 31 Mr. Asquith postponed the Irish Amending Bill and all controversial business, announced that the issues of peace and war were hanging in the balance, and that it was of vital importance that Great Britain should present a united front. Mr. Bonar Law expressed his full agreement; stating that he spoke for Unionists as well as for Unionists.

The implications of the entente with France and of the subsequent understanding with Russia were not generally grasped even yet. Serbia had few sympathizers in England, the brutal murders of King Alexander and his Queen having never been forgotten. Germany's apparent reasonableness in the Balkan negotiations had lulled for the time public and even ministerial suspicions of her designs. Some leading journals, and notably *The Times*, did yeoman's work in insisting on the necessity, even from the most selfish point of view, of Britain standing by France. The principal Liberal journals, however, notably the *Daily News* and *Manchester Guardian*, protested vehemently against any departure from neutrality. The Cabinet were as divided as the public, the bulk of the more Radical members pronouncing for neutrality, while Sir E. Grey, supported by the Prime Minister and others, insisted on British obligations to France. In consequence Sir E. Grey could not give, on July 31, the promise to co-operate with France for which M. Cambon, the French ambassador, asked; nor could the King respond in anything except friendly generalities to an earnest appeal from the French President. But on Saturday Aug. 1, the day on which Germany declared war on France, there was a hurried summons of such members of the Unionist Opposition as could be collected at the week's end; and as a result of their meeting Mr. Bonar Law wrote on the Sunday to the Prime Minister as follows:—

"Lord Lansdowne and I feel it our duty to inform you that in our opinion, as well as in that of all other colleagues whom we have been able to consult, it would be fatal to the honour and security of the United Kingdom to hesitate in supporting France and Russia at the present juncture; and we offer our unhesitating support to the Government in any measures they may consider necessary for that object."

This, the natural outcome of the patriotic support which, in spite of acute domestic differences, the Opposition had throughout afforded to the foreign policy of Sir E. Grey, immensely strengthened the stalwarts in the Cabinet; and the evasion by Germany of Sir E. Grey's demand that she should respect the neutrality of Belgium helped them still more. Accordingly, on Monday Aug. 3 the Foreign Minister was in a position to make a speech of vast historic moment, inviting the House of Commons to act up to the obli-

Britain and the Crisis.

Naval and Presidential Visits.

Lord Roberts and National Defence.

Division of Opinion.

Naval and Military Proposals.

Unionist Attitude.

Sir E. Grey's Speech of Aug. 3.

gations that England had incurred. These involved, he explained, will regard to Russia, no more than diplomatic support. With regard to France, he had told her, at the crisis which led to the Algierais Conference, that, if war were forced on her about Morocco, he believed that British public opinion would rally to her support. Since that time conversations had taken place between French and British naval and military experts, which, however, did not bind their Governments. In the Agadir crisis he had taken the same line, and in Nov. 1912 it had been agreed that, if either Great Britain or France had grave reason to expect an attack by a third Power or a menace to the general peace, both Governments should consult whether, and if so how, they should cooperate. There was no definite promise of intervention; but in the existing crisis, in view of Anglo-French friendship, he invited every man to look into his own heart and construe the extent of the British obligation for himself. In view of that friendship, France had concentrated her fleet in the Mediterranean; Britain could not let France's unprotected coasts be bombarded. Accordingly he had told the French ambassador that, if a hostile German fleet came into the Channel or the North Sea, Britain would give France all the assistance in her power. The German Government had offered, in the event of British neutrality, to refrain from attacking the northern ports of France; but that was far too narrow an engagement. Then came the urgent question of Belgium. He had asked France and Germany whether they would respect Belgian neutrality. France had agreed, Germany had delayed replying, and had now issued an ultimatum to Belgium. Germany had asked if Britain would be satisfied with the preservation of Belgian integrity after the war, but the Government had refused to barter away British interests and obligations. The King of the Belgians had appealed to King George. If Great Britain stood aside, she could not prevent Europe falling under the dominion of a single Power. Ireland was the one bright spot. The feeling there made it unnecessary to take the Irish question into account. Unconditional neutrality was precluded by the commitment to France and the consideration of Belgium. To stand aside would be to sacrifice the good name of Great Britain without escaping the most serious economic consequences. The forces of the Crown were never more ready or efficient; the Government, which had wished for peace, appealed to the country for support.

The speech finally convinced the country and the Empire of the righteousness of the cause. Mr. Law promised full support.

Mr. Redmond electrified the House by saying that Irish feeling had completely altered towards England, and British troops might be withdrawn, as Ireland would be defended by her own armed sons. Mr. Ramsay Macdonald, indeed, the leader of the Labour party, and some individual Liberals and Labour men, condemned any departure from neutrality; but it was made clear that the bulk of the Liberals and even of the Labour men were with the Government. Only two Cabinet ministers, Lord Morley and Mr. Burns, resigned. Next day Great Britain issued her ultimatum to Germany to respect Belgian neutrality; and, Germany refusing, she declared war.

Sir Edward Grey had said that the forces of the Crown were never more ready or more efficient. The navy, through the foresight of the First Lord (Mr. Churchill), and First Sea Lord (Prince Louis of Battenberg), afterwards the Marquess of Milford Haven), was already mobilized, the demobilization of the magnificent fleet which the

King had recently reviewed at Spithead having been countermanded in view of the European crisis; and it proceeded at once to its stations in the North Sea, under the command of Sir John Jellicoe. The German mercantile marine was soon swept, with slight exceptions, from the seas, and a blockade of Germany set up. Though the army was small and unequal to a great continental war, the Expeditionary Force, which Lord Haldane had fashioned, was also ready, and Sir John French, the Inspector-General of the Forces, was its commander. The Army Reserve was at once called out and the Territorial Force (also Lord Haldane's creation) embodied. It was necessary immediately to appoint a Secretary of State for War, the seals of the office

having been held since the spring by Mr. Asquith in addition to the Premiership. In response to public demand, Lord Kitchener, who was starting to resume, after a visit to London, his duties as British Agent in Egypt, was kept at home to take over the War Office as a non-political chief. There was some disposition at first, both in the Cabinet and in the Liberal press, to endeavour to confine the British share in the war to the sea, and to object to sending soldiers to fight in France. No more was heard of this after Lord Kitchener's appointment. The Expeditionary Force was despatched in perfect secrecy and perfect safety in the first half of the month, and was ready for action in France on Aug. 21. Another great service which Lord Kitchener rendered his country and the world was to bid the British Empire prepare for a three years' war and raise troops to be reckoned in millions rather than thousands. He started to organize a new army, which was popularly known as Kitchener's Army, applications for commissions poured in, and recruiting was extraordinarily brisk and general during the remainder of the year, especially after the news of the retreat from Mons. The disposition of all classes of young men to go to the front was sensibly increased when the young Prince of Wales went to join Sir J. French's staff in October. Large camps were formed in all parts of the country, the most extensive training ground being Salisbury Plain. From all the dominions and colonies and from India came immediate offers of help.

The dislocation of business in London, the financial capital of the world, promised at first to be extremely serious. On the Friday before the outbreak of war the Stock Exchange, an hour after its opening, closed *sine die* and the Bank rate was advanced to 10 per cent. Happily the following Monday was the August bank holiday; the bankers and merchants met and invited the Government to prolong this interlude for three days. This was promptly done; a Postponement of Payments bill supplemented the Moratorium proclamation and was extended to a period of one month; the Government meanwhile relieved the monetary crisis by issuing new Treasury currency notes for £1 and 10s. The Bank rate was reduced after the bank holidays to 6%, and before long to 5%. By these prompt measures, the first financial flurry was quickly overcome. A vote of credit for £100,000,000 was proposed in the House of Commons by the Prime Minister, together with an immediate increase of 100,000 men for the army and of 67,000 for the navy and coastguard. The war, he said, had been forced on the country, and no nation ever entered a struggle with a clearer conscience.

Other immediate steps taken by the Government involved the control of the railways, and the setting up of a system of insurance of war risks, so as to secure the continuance of overseas trade; the passing of a Defence of the Realm Act authorizing trial by court-martial of spies and of persons contravening regulations made for national safety, and of bills enabling Great Britain to take advantage of enemy patents, to requisition stores for the army, and foodstuffs "withheld unreasonably" in order to raise their price, and to supplement deficiencies in housing. Other legislation, passed before Parliament was prorogued, provided for special constables, for restriction of the sale of liquor, and for giving emergency powers to the courts for the protection of debtors. Measures cabalated to relieve distress were pushed forward, but the anticipated distress from unemployment did not occur, and a great fund for its relief, running into many millions, which was organized under the presidency of the Prince of Wales, had eventually to be diverted into other directions.

An enormous amount of voluntary effort seconded Government activity. Private houses were freely offered for hospital purposes, yachts were converted by their owners into hospital ships; in every profession men who had retired returned to release younger men for Kitchener's Army; women, encouraged by the precept and example of the Queen, set themselves in all parts of the country to make under-

Lord Kitchener at the War Office.

Kitchener's Army.

Bank holidays of August.

War Measures.

Voluntary Effort.

Entry into the War.

Naval and Military Activities.



clothing, and knit socks for sailors and soldiers; and *The Times* accepted, with unprecedented success, the office of organ for collecting money for the British Red Cross and Order of St. John for the benefit of the wounded. Yet in spite of the various drains on manhood, time and purse, and of the cruel anxieties, as the tale of losses came in, in every house in the country, the public adopted as its motto "Business as usual," and carried on, so far as practicable, as if the nation were at peace. There was some, but comparatively little, panic at the outbreak of war as to food-stuffs, and a certain amount of hoarding, but no serious shortage.

The abandonment of party strife entailed upon the Ministry one difficult decision: Were the Home Rule bill and the Welsh Disestablishment bill, which had passed in three successive sessions through all their stages in the Commons, but which had been vehemently opposed by the Unionists, and rejected by the Lords, to be allowed to become law automatically under the Parliament Act? Ministers, influenced no doubt largely by the desire to meet Mr. Redmond's magnanimous attitude at the outset of the war, determined to submit them to the King for signature, with the reservation that neither should be put into operation during the war, and that special arrangements should be made to meet the case of Ulster. The Opposition protested that this decision was a breach of faith, and denounced the Suspensory bill which the Government introduced and passed; but they maintained their patriotic attitude unchanged. Their leaders generally had placed themselves at the disposal of the Government, and the services of Mr. Austen Chamberlain, Mr. (afterwards Lord) Long, and Mr. R. E. Smith (afterwards Lord Birkenhead) had been accepted. Mr. Smith was made head of the Press Bureau, in order to give out "a steady stream of information." The press had shown as a body remarkable discretion about naval and military secrets, so that the arrival of the Expeditionary Force in France was a complete surprise to the Germans. But the secrecy necessarily observed gave rise to extraordinary rumours which were widely accepted as fact. The most notorious was the story, for which there was no foundation whatever, that trainloads of Russian troops, arrived from Archangel, had passed through England to aid the French in their fight against the German invaders.

Internal strife came to an end, not merely between parties in the House of Commons, but throughout the country. Political propaganda ceased. All strikes were promptly settled, including the great building strike in London. A general amnesty was proclaimed for offences in connexion with industrial disturbances and for suffragist prisoners. The women's agitation for the suffrage was suspended; "militancy" on their part was dropped; suffrage societies organized themselves for the relief of women and children who suffered by the war; many of the leading militants diverted their oratorical talents to the promotion of recruiting. The nation was at one. The Churches impressed upon their adherents the need for endurance and sacrifice, and upheld the righteousness of the national cause. Friday August 21 was appointed as a special day of intercession for soldiers and sailors, and crowded services were held all over the land, the King and Queen attending at Westminster Abbey.

There was considerable alarm in the country, for a long time, in regard to German spies. Railways, bridges, and waterworks were in consequence guarded by Territorial troops and Boy Scouts. Aliens were registered, and restricted in their freedom of movement and residence. The outcry against aliens led Adm. Prince Louis of Battenberg, the First Sea Lord, to retire owing to his German origin. Several spies were arrested and tried, and a certain number shot.

The control of the war, as of all other portions of British policy, rested with the Cabinet. It was assisted by the Committee of Imperial Defence, and the War Office and Admiralty acted as executive agents. But a Cabinet of over 20 members, a large proportion of whom were immersed in details of internal policy, was obviously unfitted for the duties of superintendence of naval and military operations. On Nov. 25 a War Council was constituted, consisting mainly of

the members of the Committee of Imperial Defence, to whom the Cabinet delegated (subject to ultimate reference to itself) the ordinary management of the war. While Mr. Lloyd George, Sir Edward Grey, Lord Haldane, and Lord Crewe had seats and influence on the Council, the principal responsibility lay with the Prime Minister, Lord Kitchener, and Mr. Churchill; indeed, as was afterwards revealed, the meetings of the War Council were so intermittent that the authority of these three was but little controlled. The public gained its authentic knowledge of military progress mainly from Lord Kitchener's statements in the Lords, and similar statements about naval operations by Mr. Churchill in the Commons.

The varying fortunes of the early weeks of the war—the German check at Liège, the retreat from Mons, the burning of Louvain, and the outrageous conduct of the Germans in Belgium and France, the escape of the "Goeben," the exploits of the "Arethusa" at sea, the advance of the Russians in East Prussia and their expulsion by Hindenburg, the brave resistance of Serbia to the Austrian attack, the threat to Paris and the removal of the French Government to Bordeaux, the victory of the Marne, the German stand on the Aisne, the torpedoing of three British cruisers in the North Sea; the death of the veteran Lord Roberts when on a visit to the army in France—were all, in one way or another, calculated to stiffen the resolution of the nation. The session of Parliament was brought to a close on Sept. 19 amid unprecedented scenes. Cheers greeted the announcement that the Home Rule and Welsh Church bills had been duly passed under the Parliament Act. The King's Speech struck a lofty note. "I address you," His Majesty began, "in circumstances that call for action rather than speech. After every endeavour had been made by my Government to preserve the peace of the world, I was compelled, in the assertion of treaty obligations deliberately set at naught, and for the protection of the public law of Europe and the vital interests of my Empire, to go to war." And he summarized British policy when he declared: "We are fighting for a worthy purpose, and we shall not lay down our arms until that purpose is fully achieved." Mr. Crooks, of the Labour party, before the members separated, started singing, "God save the King," in which all present joined upstanding; and then he exclaimed, "God save Ireland," to which Mr. Redmond responded, "God save England."

The Prime Minister had already, before the close of the session, started, with the co-operation of leading men of all parties, a great educational campaign, by means of meetings throughout the United Kingdom, to vindicate the justice of the British cause and to organize public opinion and effort. The first meeting was at the Guildhall on Sept. 4, and was addressed by Mr. Asquith, Mr. Bonar Law, Mr. Balfour, and Mr. Churchill. Others were held in rapid succession in different parts of the country, the Prime Minister speaking himself not only in London but in Edinburgh, Cardiff, and Dublin. In Dublin the Lord Mayor was in the chair, and the speakers included (besides the Prime Minister) the Lord Lieutenant, the Chief Secretary, Mr. Redmond, Mr. Dillon, and Mr. Devlin. Mr. Redmond said that Ireland, which was profoundly moved by the sufferings of Belgium, would feel bound in honour to take her place beside the other autonomous portions of the King's Dominions. At a meeting in the London Opera House Mr. Crooks said that the fight was for liberty and home; he would rather see every living soul blotted off the face of the earth than see the Kaiser supreme anywhere. One of the most striking speeches was delivered by Mr. Lloyd George to a meeting of Welshmen in the Queen's Hall in London. The German Chancellor, he said, has called treaties "scraps of paper." So were bank-notes; so were bills of exchange. Treaties were the currency of international statesmanship. It was a great opportunity, and a new and more exalted patriotism was emerging. Britain had been living, he said, in a sheltered valley; the stern hand of fate had scourged her to an elevation whence the great peaks of honour were visible—Duty, Patriotism, Sacrifice. The Prime Minister summed up the position of the

Fate of Home Rule Bill.

Patriotism in Further speech.

Operation of Internal Strife.

The Country and the War.

Spies and Aliens.

War Council.

country in his speech at the Guildhall on Lord Mayor's Day. Britain, he said, would not sheathe the sword until Belgium had recovered all and more than all that she had sacrificed, until France was adequately secured against the menace of aggression, until the rights of the smaller nationalities were placed on an unassailable foundation, until the military dominion of Prussia was fully and finally destroyed.

Meanwhile England was feeling day by day more and more what it meant to be at war. On the coasts, and especially the east coast, houses were destroyed which might either obstruct the British line of fire or serve as landmarks for a hostile fleet; lamps were extinguished on the sea front and all streets leading to it; no lights were allowed to be shown from private houses; and lighthouses and lightships were temporarily extinguished. The development of air warfare shortly caused the streets of London and all towns accessible from the east to be darkened, and searchlights, special guns, and an increasing number of air machines to be held in readiness against attack; while all trains in the south-eastern quarter of England had to have their blinds drawn after nightfall. The fall of Antwerp and the loss of the Belgian coast to the enemy brought the imminence of the danger home. These events in Belgium brought also a great accession to the number of Belgian refugees who had already sought shelter in England, and a vast organization of public and private benevolence catered for their needs. On the other hand, public opinion in England was cheered about this time by the arrival of the first contingent of Canadian troops, the forerunner of a mighty force from all the Dominions; and by the appearance in the battle line in France of native troops from India. This was unfortunately succeeded by the news of the defeat of Adml. Craddock at Coronel.

The new parliamentary session, which opened on Nov. 11, followed immediately upon a serious development of the conflict—the entry of Turkey into the war as an ally of the Central Powers (which had as one result the proclamation of Egypt as a British Protectorate). The King, in his Speech, said that “the only measures which will be submitted to you, at this stage of the session, are such as seem necessary to my advisers for the attainment of the great purpose upon which the efforts of the Empire are set.” The most burning question of the moment was the scale of pensions and disablement allowances for sailors and soldiers and their dependents. Mr. Asquith welcomed a suggestion made by Mr. Law that it should be referred for decision to a small committee of all parties. Mr. Arthur Henderson, who had succeeded the pacifist Mr. Ramsay Macdonald as chairman of the Labour party, promised the full support of organized labour in maintaining unity.

The finance of the war claimed the immediate attention of Parliament. The Prime Minister moved a Vote of Credit for £225,000,000, and a further addition of a million men to the army. On Nov. 17 the Chancellor of the Exchequer explained how it was proposed to raise the money. He had to provide for a deficit of nearly 340 millions. Following the precedents of Pitt in the French War and Gladstone in the Crimean War, a substantial part of this must be obtained by increased taxation levied on all classes. He proposed to double the income-tax (bringing it up to 2s. 6d.), and super-tax, to add the equivalent of a halfpenny a half-pint to the taxation of beer, and to raise the duty on tea from 5d. to 8d. In a full year, he calculated that these increases would bring in over 65 millions. He further announced the immediate issue of a loan of £150,000,000, at 3½%, at 95, which was promptly subscribed. He calculated the cost of the first full year of war as at least £450,000,000. Other important war measures taken at this time were the purchase by Government of 128,000,000 worth of sugar—a foretaste of the coming control of food supplies, not yet expected; a scheme for the manufacture of aniline dyes, hitherto made exclusively in Germany—the consumers to subscribe three millions, and the Government to guarantee debenture interest on another million and a half; the setting up by statute of a custodian of enemy property in the person of the Public Trustee.

At the end of November the King crossed to France, and spent a week with his army in the field. The visit, which was repeated in subsequent years of war, greatly cheered and sustained the troops. Almost immediately afterwards came the news of Adml. Sturdee's victory off the Falkland Isles. But this was succeeded by evidence that, even though invasion of England in force might be too hazardous to be attempted, the country was exposed to harassing and destructive attacks by sea and air. On the morning of Dec. 26 German warships appeared off Hartlepool, a great business port, and Scarborough and Whitby, two much-frequented watering-places, and bombarded all three towns, doing considerable damage, and killing some 140 people, and wounding many others, mostly civilians, including women and children. The ships only remained for half an hour and then disappeared in the mist; before any portion of the British fleet, save patrol boats, could come up. On Christmas Eve a German aeroplane dropped a bomb in a bed of cabbages near Dover Castle; and at midday on Christmas Day another got up the Thames as far as Erith, but was then chased off. These events produced no panic, but stimulated recruiting, which remained brisk in England, though in Ireland Mr. Redmond's efforts were only moderately successful.

Speaking in December, Mr. Bonar Law, while rightfully claiming that the Opposition had distinguished itself from previous war-time oppositions by its patriotic reticence, remarked that perhaps, indeed, they had not criticized the Government enough. The early months of 1915 witnessed a change. It was clear that the war, which in the west had settled down into trench-fighting, would last for a considerable time, even assuming that the “steam-roller” of the Russian advance would eventually cause the German strangle-hold on north-eastern France to relax; it was not so clear that all that the Government had done and left undone was judicious. Criticism therefore awoke, and became steadily more insistent till the formation of the first Coalition Ministry. But it was criticism, not on party lines, directed to the more efficient conduct of the war; the criticism from the pacifist side was negligible. It was urged that voluntary enlistment, though hitherto fairly adequate, could not possibly give the army all the men it would want; that the half-hearted British policy of search and blockade, though it provoked reasoned objections from the American Government, failed to do any serious harm to Germany; that steps should at once be taken to regulate the price of food, which was steadily mounting; that the Press Bureau, under Sir Stanley (afterwards Lord) Buckmaster, was unduly harassing; that quite undue mildness was shown in the treatment accorded to enemy aliens, who should all be interned, that insufficient attention was paid to the development of the air force; and, above all, that the Government had entirely failed to meet the requirements for munitions of war.

Feeling in England was hardened by the German proclamation of Feb. 4, declaring a blockade of Great Britain from Feb. 18, claiming the right in the war-region to destroy British ships without providing means of escape for passengers and crew, and warning neutral ships that they might incur the same fate. “This,” as Mr. Asquith said, “is in effect a claim to torpedo at sight, without regard to the safety of crew and passengers, any merchant vessel under any flag.” It was resolved, in consequence, to detain, and take into port, ships carrying goods of presumed enemy destination, ownership or origin; and also to discriminate against submarine prisoners, as having disregarded the laws of war. The sinking of the “Lusitania,” in accordance with this proclamation, by the Germans on May 7, with a great loss of life among innocent passengers, largely American, brought the aliens question in England to a head, as it produced violent anti-German riots and demonstrations all over the country. It was decided to intern or deport all enemy aliens, and to scrutinize carefully the cases of naturalized Germans. Widespread indignation had already been aroused this spring by the

German Attacks by Sea and Air

Revival of Criticism

Blockade of Britain

Internment of Aliens

reports of American agents about the treatment meted out to British prisoners in Germany; and this was increased in May by the publication of the report of a committee, presided over by Lord Bryce, confirming the stories of outrage committed by the Germans in Belgium and France. The Prime Minister had no difficulty in obtaining a supplementary Vote of Credit for £37,000,000, and a fresh Vote of Credit for £50,000,000, the cost of the war having already reached two millions a day.

The great difficulty with which the Government had to cope this spring was the insufficient supply of munitions of war, due mainly to strikes, to trade-union practices favouring slow production, and to drink. Appeals were made to the working men by Lord Kitchener; and on March 9 Mr. Lloyd George introduced a new Defence of the Realm bill, giving the Government wide powers of mobilizing industry. On March 17 the Chancellor of the Exchequer met the representatives of 35 trade unions, and pointed out to them that the duration of the war depended on the rate at which munitions could be turned out. Ultimately an agreement was reached under which there was to be in no case any stoppage of work upon munitions and equipments of war; all differences were to be the subject of conference between the parties and in case of disagreement to be referred to arbitration; trade practices were to be relaxed during the war period. In harmony with the spirit of this agreement there was enrolled at Liverpool, under Lord Derby's command, a Dockers' Battalion. With regard to drink Mr. Lloyd George told a deputation of shipowners which advocated total prohibition during the war: "We are fighting Germany, Austria, and drink; and, as far as I can see, the greatest of these three deadly foes is drink." In order to set a good example the King announced that he would give up all alcoholic liquor till after the war, and issued orders against its consumption in the Royal Household. Lord Kitchener, and a considerable number of loyal subjects, followed His Majesty's example: On April 20 Mr. Lloyd George introduced the ministerial proposals which increased enormously the taxation on all alcoholic liquors, and included powers to close and control public-houses in munition areas. But public opinion was not ripe for so stringent a measure, and compelled the withdrawal of these proposals; and the Government contented themselves with setting up a Liquor Control Board with Lord D'Abincron (formerly Sir Edgar Vincent) as chairman, which drastically reduced the alcoholic strength of beer and spirits, in munition or populous areas, and the hours during which public-houses might be open and liquor sold. Only for some two hours in the middle of the day and for some three hours in the evening could drink be procured; and the arrangement worked well.

The question of munitions became critical in April and May. The battle of Neuve Chapelle in March had been indecisive owing to a deficiency of ammunition, which was revealed to the people of England by a dispatch from the Military Correspondent of *The Times* (Col. Repington). Mr. Asquith indeed, in a speech at Newcastle-on-Tyne mainly devoted to encouraging munition workers to deliver the goods "more promptly and more effectively," amazed and angered the public by denying that operations in the field had been crippled through lack of ammunition. But Lord Kitchener confessed that "the output is not equal to our needs"; and Mr. Lloyd George dwelt in the House of Commons on the unprecedented expenditure of artillery ammunition and the new importance given to high explosives. The problem, he said, was to produce munitions not only on a much larger scale than ever before but of a different kind. To the anxieties caused by the deficiency of munitions were added those due to the desperate resistance with which the troops, just landed with high hopes on Gallipoli, had been met. Disagreement about the Dardanelles operations between Mr. Churchill, the First Lord of the Admiralty, and Lord Fisher, the First Sea Lord, came to a head; and the Prime Minister, who had on May 22 contradicted the current rumours of coalition, formally told the House a week later that the Government was to be reconstructed "on a broader personal and political basis."

The reconstruction took place during the Whiteside recess, it being carefully explained by Mr. Asquith that there was no change of policy and no sacrifice by any minister of his political ideals. The Coalition was "for the purpose of the war alone." Mr. Asquith, Sir Edward Grey and Lord Kitchener retained their respective offices, and Lord Crewe remained Lord President and leader in the Lords; Lord Lansdowne joined the Ministry without portfolio; Mr. Bonar Law became Colonial Secretary; Mr. Balfour took over the Admiralty from Mr. Churchill, who became Chancellor of the Duchy; Mr. Austen Chamberlain went to the India Office; and Lord Curzon, Mr. (afterwards Lord) Long, and Lord Selborne also entered the Cabinet. Mr. Asquith sought the co-operation of both the Irish leaders in his Cabinet; but, while Sir Edward Carson accepted the Attorney-Generalship (having Mr. F. E. Smith as Solicitor-General), Mr. Redmond declined to enter. Mr. Henderson, the leader of the Labour party, became President of the Board of Education. Public opinion would not tolerate the retention of Lord Haldane, with his German associations, as Lord Chancellor. The post was declined by the Attorney-General, Sir John Simon, and he became Home Secretary. The Solicitor-General, Sir Stanley Buckmaster, was accordingly promoted to the woolsack as Lord Buckmaster. The vital importance of guns and ammunition was recognized by the creation of a new Ministry of Munitions, at the head of which was placed the most energetic member of the late Ministry, already rivaling Mr. Asquith in reputation, Mr. Lloyd George. Mr. McKenna succeeded to the Chancellorship of the Exchequer, and Mr. Runciman, Mr. Birrell, Mr. McKinnon Wood and Mr. Harcourt remained in the Cabinet. The Liberal ministers who retired, besides Lord Haldane, were Lord Beauchamp, Mr. Hobhouse, Mr. Pease, Lord Lucas and Lord Emmott; Mr. Herbert Samuel became Postmaster-General, but was excluded from the Cabinet; and Mr. Montagu became Financial Secretary to the Treasury, Lord Robert Cecil Under-Secretary for Foreign Affairs and the Duke of Devonshire Civil Lord of the Admiralty; Mr. Brace, the Labour member, was appointed Under-Secretary for Home Affairs.

The country, which was cheered this May by the entry of Italy into the war on the side of the Allies, welcomed the new Ministry as giving promise of a more strenuous conduct of hostilities. Mr. Lloyd George threw himself with ardour into his new work, enlisted the aid of business and practical men and men of science in its organization, and made a personal appeal to the great towns, Manchester, Liverpool and Cardiff, to concentrate on enlarging the output, and to consent to the modification of such trade-union rules as conflicted with rapid and efficient production. It was in the workshops of the country, he said, that success must be sought. He urged the conversion of workshops engaged in the arts of peace into factories for turning out munitions of war. Mr. Lloyd George got at once to work on the lines he had laid down. He brought in on June 23 a Munitions of War bill, embodying his plans for increasing output. They were based on a system of decentralization. There were to be 10 munition areas, managed by local business men. There must be no strikes or lockouts; disputes must be referred to arbitration. Skilled men must be brought back from the army; Munition Courts appointed, representative of Government, employers and workmen; trade-union regulations restricting output must be suspended; and employers' profits limited. These proposals, with some modifications, were accepted by the Labour leaders; and the bill promptly became law.

But the Act by no means put a complete stop to labour troubles. In July the South Wales miners suddenly demanded a new minimum rate of wages higher than the previous maximum. Mr. Runciman, President of the Board of Trade, in vain endeavoured to compose the quarrel. The Government applied the provisions of the Munitions Act with no result, and a card vote gave a majority for a strike. Mr. Lloyd George went down to Cardiff and effected a settlement by an advance on

First  
Coalition  
Ministry.

The Drink  
Question.

Weakness  
of  
Government.

Mr. Lloyd  
George as  
Minister of  
Munitions.

Strike of  
South  
Wales  
Miners.

Mr. Rundman's conditions, after a week's strike had cost the country £1,500,000. The continued increase in the price of coal consequent on these events caused the Government to pass a Price of Coal (Limitation) bill, which was only accepted by Parliament with reluctance. The King made in July a tour of the munition centres in the Midlands to thank and hearten the workers of both sexes. Mr. Lloyd George was able in the debate on adjournment on July 28 to give a reassuring account of the success of his department, which had enrolled nearly 100,000 volunteers, had brought back thousands of qualified engineers from the ranks, and had set up some 20 national factories. But, as a result of a recent conference at Boulogne, it had been decided to embark on a new programme of great proportions which would necessitate 20 new establishments and need further volunteers, and especially the assistance of women.

Once more he appealed to trade-union leaders to bring pressure upon their men to suspend trade-union practices restricting output, and he attended a conference in the London Opera House on the following day with representatives of the coal-mines industry, in which there was a general disposition to meet his views. But these practices continued; and yet once again Mr. Lloyd George, addressing on Sept. 27, by invitation, the Trade Union Congress at Bristol, pointed out that, while the Government had kept its promises, intercepted war profits, and taken control of the whole of the engineering works of the country for the benefit of the State, labour had failed in too many instances to reciprocate. Objections were raised to semi-skilled and unskilled labour in place of skilled; to women replacing men; to night work; to artisans working their hardest. It was a war, he explained, of material, and the Russian retreat of that autumn threw a heavier burden on England. "I beg you, do not set the sympathy of the country against Labour by holding back its might with the fetters of regulation and custom." The speech produced a great effect on the Congress and materially improved the conditions prevailing in the workshops.

The finance of the war was the next most urgent question for the Coalition to tackle. The Prime Minister moved on June 24 a supplementary Vote of Credit for £350,000,000, and anticipated a war expenditure of three millions a day. The new Chancellor of the Exchequer, Mr. McKenna, presently obtained Parliamentary sanction for a fresh War Loan, to be issued at 4½%, at par, with special arrangements, through the post-offices, trade unions, friendly societies, and factories, for the encouragement of the small investor, who could obtain bonds of £5 or vouchers for 5s. A great campaign was at once started in support of the loan and of war economy, beginning with a meeting of bankers, merchants, manufacturers and shopkeepers of the City of London in the Guildhall. Mr. Asquith and Mr. Bonar Law were the principal speakers. The Prime Minister commended the loan as the first great democratic loan in British history, and he urged the imperative necessity of reducing all expenditure on luxuries. The loan was a great success, and realized nearly £600,000,000, including 200 millions from the big banks. At the end of July the Prime Minister had to apply for a further Vote of Credit amounting to £150,000,000. A Retrenchment Committee with Mr. McKenna as chairman, was appointed to inquire into civil expenditure.

The formation of the Coalition Ministry did not abate the movement for compulsory military service, a movement which was met by strong demonstrations in favour of retaining the voluntary system, including a pronouncement in that sense by the Trade Union Congress in the autumn. The Government adopted the intermediate measure of introducing a National Registration bill—applicable to all persons between 15 (eventually changed to 16) and 65. This, though resisted by some Radicals and Labour men, was carried into law without much difficulty. They also passed an Elections Registration bill, postponing local elections and suspending registration of voters. But they could not bring themselves to take strong steps to secure the production of food, declining to accept the recommendation of a committee

of agricultural experts over whom Lord Milner presided, that there should be a guaranteed minimum price of wheat for the four years following the 1916 harvest.

The agitation for compulsory service increased in the autumn, and dominated the internal politics of the country and the proceedings of Parliament. Lord Kitchener, who had hitherto resisted the movement, confessed that the provision of adequate forces in the field caused him anxious thought. Independent members of Parliament pressed the compulsory solution upon the Government. While Radicals and Labour men and Irish Nationalist politicians deprecated the tread of public opinion, the unsatisfactory course of the war spoke loudly. Zeppelin raids had brought home the hard facts of war both to the Londoner and to the countryman; and the defence was clearly inadequate; Russia, on whose early successes optimism had fastened, had been driven back by the Germans. Before the autumn was far advanced, it was evident that some decisive action must be taken in regard to the gallant, but fruitless, Gallipoli adventure. Bulgaria, on a shrewd, but shortsighted, appreciation of the situation, came into the war on the German side. Greece, put to the test, declined, under the influence of her King, to honour her pledge to aid Serbia, which was in consequence heavily defeated and overrun. In France the British offensive at Loos; and the French in Champagne, had seemed to promise well, but no real progress had been made; and Sir John French, after 14 months' incessant strain, gave up in October the command of the British forces, and was succeeded by Sir Douglas Haig. In the effort to stave off a decision on compulsory service Lord Derby was asked, and consented, in October to assume the direction of recruiting. He inaugurated a most strenuous campaign, ushered in by a spirited letter from the King. Men were divided into various groups, and the unmarried men were to be taken in preference to the married men. Lord Derby spent himself without stint, and there was a great rush of recruits; but before the end of December it was clear that an adequate number of unmarried men would not be obtained. In November Mr. Asquith had said that, if Lord Derby's scheme were not a success, he would, "without the faintest hesitation or doubt," ask the House to sanction some form of legal obligation. The time had come. Mr. Asquith moved on Dec. 21 for an addition of a million men to the previous three millions voted for the army, and the Cabinet accepted the principle of compulsion, at the cost of losing Sir John Simon, the Home Secretary.

In the press the principal demand for compulsion came from *The Times*, which had throughout been a strong advocate for more strenuous prosecution of the war. Another vital matter, to which it called attention again and again this autumn, was the necessity of entrusting the uncontrolled conduct of the war to a very small Cabinet. This demand was echoed in the House of Lords on Oct. 26 by Lord Cromer, who said that what the public wanted to see was a small, strong, executive body chosen from men representing the best talent in the country; and on Nov. 2 by Sir Edward Carson, who had resigned office owing to dissatisfaction with the Balkan policy of the Government, and who said that responsibility could only properly be concentrated by the reduction of the Cabinet to five or six members. Mr. Asquith endeavoured to meet this demand by promising to commit the strategic conduct of the war to a committee of not less than three and not more than five members, having elastic relations with the Cabinet. Apparently the old War Council had been allowed to become obsolete. Mr. Asquith announced, on Nov. 11, that, in the absence of Lord Kitchener, who went in that month to Gallipoli to acquaint himself with the situation, the new War Committee would consist of himself, Mr. Balfour, Mr. Lloyd George, Mr. Bonar Law, and Mr. McKenna. The exclusion of Mr. Churchill from the conduct of the war brought about his resignation from the Cabinet and his departure for the western front as a British military officer.

Trade-Union Practices and Activities.

Agitation for Compulsory Service.

Lord Derby's Recruiting Campaign.

War Loan of 1916.

Demand for a Small War Cabinet.

National Registration Bill.

The secrecy enforced upon the press produced many protests, until the Press Bureau was placed under the competent headship of an able journalist, Sir Edward Cook, and a leading ex-colonial administrator, Sir Frank Swettenham. One urgent matter dealt with by Parliament (which sat continuously, with short intervals of prorogation or adjournment, throughout the war) was the question of its own existence, which under the Parliament Act should terminate in December of this year, but which was prolonged by statute this autumn, and by subsequent statutes in subsequent years, till after the conclusion of the war. Further powers were given to the Munitions Ministry by a bill passed in December; and Mr. Lloyd George, while claiming that the output of munitions had been prodigiously increased, urged the imperative need of further efforts, especially by the method of "diluting" skilled labour by the introduction of women. The footsteps of the Allies, he warned Parliament, had been dogged by the spectre of "Too late."

One vitally important matter, the finance of the war, was resolutely grappled with this autumn by the Coalition Government, and by Mr. McKenna, its Chancellor of the Exchequer. The cost of hostilities was rapidly mounting. In moving a Vote of Credit in Sept. for £250,000,000, the Prime Minister said that it had risen in the past half year from £4,700,000 to over £5,500,000 a day; in moving a similar Vote for £400,000,000 in November, he estimated for an expenditure of £5,000,000 a day. In these circumstances a strenuous effort was made in the third war budget in September to raise a large portion of the outlay by taxation. In the previous year Mr. Lloyd George had doubled the income-tax and super-tax, and greatly increased the taxes on beer and tea. Beer, which was now severely limited by the Board of Control, Mr. McKenna left alone. But he increased the income-tax once more by 40%, and reduced the exemption limit, while permitting payment in half-yearly instalments. Super-tax was also increased. He imposed a new excess-profits tax—to tap the lucrative gains of war manufacture—of 50 per cent. He increased the taxation on sugar enormously; added 50% more in duties on tea, tobacco, cocoa, coffee, chicory and dried fruits; raised the duty on motor spirit by 3d. a gallon, and doubled the patent-medicine duty. He abolished the halfpenny post, increased the 6d. telegram to 9d., and made the press telegraph charges self-supporting. He undertook an entirely new departure by taxing foreign luxuries, putting a 33 1/3% ad valorem duty on imported motor-cars and cycles, cinema films, clocks, watches, musical instruments, plate-glass and hats. These new taxes were estimated to bring in £107,000,000; but he placed the expenditure at £1,590,000,000, and the revenue, on the basis of existing taxation, at £172,110,000, so that there was a wide margin still to be filled by borrowing. There was some attempt to raise in debate the issue of Free Trade and Protection; but with the exception of the plate-glass and hat taxes, which were abandoned, the budget had an easy passage through Parliament.

Mr. McKenna's First Budget.

When the year 1916 opened there was a general agreement that the war had become to an enormous extent a war of attrition, and the Cabinet therefore proceeded at once to bring in the Compulsory Service bill, to which circumstances had, however reluctantly, driven them. It was far from being universal. It merely treated unattested single men and childless widowers between the ages of 18 and 40 as if they had attested under Lord Derby's group system. Ireland was excluded from the bill, and exemptions were allowed for ministers of religion, men medically rejected of physically unfit, those employed in necessary national work, those who were the sole support of dependents, and "conscientious objectors" to combatant service. Tribunals were set up to deal with claims for exemption. Sir John Simon led a small and dwindling opposition; but many of the Labour members, including Mr. Henderson, the leader of the party, supported the bill; Mr. Richmond, who led to Nationalists into the lobby against the first reading, withdrew Nationalist opposition on perceiving the united demand in Great Britain in its favour; and the second

Military Service Bill.

reading was carried by 437 votes against 99. No hostile amendment received any serious support in committee, and the bill was read a third time by 383 votes against 36. In the Lords the measure was passed without a division, Lord Derby explaining that there were at least 650,000 unattested single men who would be affected by it. There was some fear that the labour organizations, who suspected the possibility of industrial co-operation, would place serious difficulties in the way of enforcing its provisions. They did indeed condemn it by a considerable majority at a labour conference held while it was passing through Parliament, but they decided not to agitate against it. Little practical effect was given to their condemnation save in the Clyde district, where in March and April strikes were organized in munition works with a view to getting this Act, and the Munitions Act facilitating dilution of labour, repealed. The singleaders, however, were arrested and deported.

The local tribunals, which were set up, proved to be, on the whole, generous in containing the exemptions; and there was in consequence strong criticism in the press and in Parliament, both on behalf of the married men, who considered that the pledges of comparative immunity made to them were impudently, and on behalf of those who were eager for the efficient conduct of the war; and who held that the purpose of the Act was being defeated. There had been organized in the House of Commons, in each of the two great parties which supported the Coalition, a War Committee, having for its sole concern the strenuous prosecution of the war. On March 21 the Liberal War Committee passed a resolution approving the extension of the principle of compulsion to married men; and powerful organs of the press, notably *The Times* and other journals of which Lord Northcliffe was the principal proprietor, proclaimed that the needs of the army could not be properly supplied without universal compulsion. On March 28 the Unionist War Committee resolved that there ought to be equal sacrifices from all men of military age; and Sir Edward Carson, a leading spirit in that Committee, urged the Government to extend compulsion universally, criticizing their hesitations. Lord Derby was also very critical in the House of Lords, and Lord Milner, in that House implored the Government to put recruiting on the only satisfactory basis: "The soldiers also pressed ministers hard. Bill a Cabinet Committee, consisting of Mr. Asquith, Mr. McKenna, Lord Lansdowne, and Mr. Austen Chamberlain came unanimously on April 14 to an adverse decision. The Cabinet did not accept their Committee's alternative scheme, but could not reach a decision. Not for the first time the Prime Minister had to ask the House of Commons for leave to postpone his official statement on the subject, telling the

Debate for War Measures.

Military Service Bill.

House that there were still points unsettled, and that the break-up of the Cabinet would be a national disaster of the most formidable kind. At length it was announced that a satisfactory decision had been reached; and on April 25, after the Easter holidays, in secret session in both Houses (the first of seven such sessions held during the war), ministers explained their proposals, which, it was found, only involved universal compulsion in case a number of other expedients which it is unnecessary to enumerate should fail to provide sufficient men. When the bill embodying the proposals was introduced by Mr. Long two days later, neither conscientious men nor anti-conscientious men found anything to say in its favour. It was withdrawn at once, and five days later Mr. Asquith announced that the Government had accepted universal compulsory service. The bill, which was introduced on May 3, brought within its operation every male between the ages of 18 and 41, and recalled time-expired men under 41 to the army. The exemptions remained as before, and Ireland was not included. In spite of Sir J. Simon's opposition, the bill passed easily through both Houses, though the method of dealing with conscientious objectors was felt to be a serious difficulty. The final step had been taken at last, but the Government had lost much of its prestige owing to the "wait and see" attitude which it had adopted.

Military Service Bill.

There were other matters relating to the conduct of the war on which the press and the public and the two Parliamentary War Committees were dissatisfied with what seemed to them the slackness and hesitation of ministers. Dissatisfaction was particularly acute in regard to two questions, which had long given anxiety; the blockade of Germany, and the development of the British air force. It was pointed out that excessive quantities of food-stuffs and other sources of military supply were going to neutral ports adjacent to Germany, and it was suggested, that the navy was hampered in the strict enforcement of the blockade by the interference of the Foreign Office. This latter charge Sir E. Grey denied on Jan. 26, but he appealed to neutral countries to make it easy for Great Britain to distinguish and discriminate. Business men were not reassured; and an excited meeting was held in the City of London on Feb. 14, with Lord Devonport in the chair, to demand a fuller and more effectual use of British sea-power. Thereupon a Ministry of Blockade was set up, with Lord Robert Cecil as its Parliamentary chief, and he shortly afterwards issued a very comprehensive list of contraband articles, and increased the stringency of the blockade. In June, after consultation with the Allies, he took the further important step of abandoning the Declaration of London, which hitherto, contrary to its interests, the British Government had observed.

Evidences of discontent with the position and development of the air forces were constantly recurring. The Germans were known to be very active in building and developing Zeppelins, and a great raid over the centre of England on Jan. 31 1916 called attention to their capacity for destruction. The system which made the British air forces ancillary to the army and navy, and divided the responsibility between Admiralty and War Office, was vehemently called in question. A demand was made for an Air Ministry; but the only changes which the Government announced in February were the transference of the British defences against aircraft from the Admiralty to the War Office, and the appointment of a joint naval and military committee to stimulate production, under the chairmanship of Lord Derby. Public dissatisfaction was strikingly shown by the return on March 19 to Parliament of a flying man, Mr. Pemberton Billing—who had no local connexion but who advocated a strong air policy—for the conservative constituency of East Herts by a large majority over a Coalition candidate. The new member took an active, if somewhat indiscriminate, part in stimulating the Government, who shortly added Lord Montagu of Beaulieu, a keen promoter of aviation, to Lord Derby's committee. But this arrangement did not last long, and in the second week in April Lord Derby and Lord Montagu both resigned, as they found the committee had no real power. Accordingly in May the Government went further, and established a Joint Air Board representing both army and navy, with Lord Curzon as president and Maj. Baird as parliamentary secretary. This departure was welcomed, though it was doubted whether even this Board would have sufficient independent power; and not only the critics, such as Mr. Winston Churchill, but Lord Curzon himself, proclaimed that an Air Ministry was destined to come—a prediction fulfilled in the following December, when Mr. Lloyd George formed his Government. The reforms already effected bore fruit in the autumn, when a Zeppelin was brought down at Cuffley by an intrepid British airman, the first of a long series of successes which constrained the enemy to rely upon aeroplanes rather than airships.

It began to be realized in the winter of 1915-6 that it was not only in arms that it was necessary to conquer Germany, but also in the field of economics. Success in arms might be compatible with defeat in the economic sphere. In January a resolution, proposed by Mr. Hewins, who had been secretary of Mr. Joseph Chamberlain's Tariff Reform Commission, and supported by Mr. Prothero, a great agricultural authority, demanding measures to bring the whole economic strength of the empire to bear in the struggle against Germany, was accepted by Mr. Runciman,

President of the Board of Trade, and carried without a division. This, conducted with the free-trade tradition, but even in Manchester, the home of free trade, the Chamber of Commerce came into line. The Chancellor of the Exchequer, Mr. McKenna, addressing the Association of Chambers of Commerce in February, said that the Government were prepared to assist in the development of foreign trade so as to ensure that England's bitterest foes and rivals should not have their former control; and Mr. Bonar Law next day announced that an economic conference would be held in Paris in the summer on this vital question. Lord Selborne, President of the Board of Agriculture, said in March that the whole attitude of Parliament towards agriculture would have to be changed; the agricultural laws must be so framed as to obtain the greatest possible national security. A great reinforcement of this propaganda was found in Mr. Hughes, the Prime Minister of Australia, who had come on a visit to England, and who made several speeches on the text that not merely must Germany's military power be destroyed, but that German control and influence in British trade and industry must be extinguished. Mr. Hughes's public appearances were received with acclamation; and he was appointed one of the British representatives at the Paris Conference, which met in the middle of June. In its final conclusions the Conference recommended (1) during the war period; co-ordination of regulations of allied countries prohibiting trading with the enemy; absolute embargo on importation of enemy goods, sequestration of enemy business, and stringent measures for restriction of enemy supplies; (2) in the reconstruction period after the war, restoration and equipment for despoiled countries; denial of most favoured treatment to enemy power, and measures for conservation of allied resources and against enemy dumping; and (3) for the peace period, measures to render allied countries independent of enemy countries in raw materials and key industries; to facilitate interchange of allied products; and to assimilate allied legislation as to patents, trademarks, and copyrights. These recommendations were received enthusiastically in England; but a minority objected to the idea of "war after the war."

The stringency of war conditions began to grip England and particularly London this spring. Public museums and galleries were to a great extent closed, and in order to economize tonnage, the importation of many bulky cargoes, especially paper pulp, and grass for paper-making, was prohibited. To ensure rapidity of production the Whitsuntide bank holiday was postponed. Economy in all directions was preached and practised; to economize coal and gas and electricity. "Summer time" Act was passed giving people an extra hour of daylight in the summer evenings; the King, whose example throughout the war was most inspiring, made a free gift of £500,000 to the national exchequer; an elaborate system of war savings was set up, under which 130,000,000 of the Government was to mature into £1 in five years. None of these restrictions or economies affected the spirit of the country; a debate raised in Parliament in February, by the small body of pacifists who inaugurated peace, only drew from the Prime Minister a repetition, amid enthusiastic cheers, of his declaration at the Guildhall on Nov. 9 1914, that Britain would never sheathe the sword until the military domination of Prussia was wholly and finally destroyed. The only criticism of the navy estimates was Mr. Churchill's complaint that the Board of Admiralty, which had succeeded him was deficient in energy and push.

Once again, perhaps the most satisfactory feature of the ministerial policy, was the resolute way in which the financial problem was faced. On Feb. 21 the Prime Minister introduced and carried two votes of credit—one a supplementary vote of £120,000,000 to cover the remainder of the current financial year, and the other of £300,000,000 to start the new year on April 1. This brought the total votes of credit since the outbreak of war to £1,782,000,000. The Chancellor of the Exchequer, in his

Economic War on Germany.

Allied Conference at Paris.

Stringency of War Conditions.

Mr. McKenna's Speech.



budget introduced on April 4, estimated the net revenue at £502,000,000 and the expenditure at £1,825,000,000; so that there was a deficit of £1,323,000,000, to be met by borrowing, which would mean a new charge, for interest at 5% and sinking fund at 1%, of £79,000,000. He tackled this unflinchingly; raised income tax to a maximum of 5s. in the pound, thus gaining £43,500,000; increased the excess profits tax from 50 to 60%; imposed an amusement tax on tickets for all public shows and a railway ticket tax on all journeys costing more than 9d.; he also took toll of matches, table-waters, cider and perry. Then he increased very seriously the duties on motor-cars, motorcycles, sugar, cocoa, coffee and chocolate. Colossal as the budget was, involving £500,000,000 of new taxation since the war began, it passed through Parliament substantially unchanged.

Mr. Asquith took advantage of Mr. Hughes's presence this spring to repeat an experiment which he had successfully made in the previous year when Sir Robert Borden, the Canadian Prime Minister, was in England; namely to invite the visiting Dominion minister to sit in Cabinet, and share in the imperial decisions on the war. He also continued his efforts to draw the

Allies into closer cooperation by attending a war conference in Paris on March 27, and then proceeding to Italy to consolidate relations with the new Ally.

Shortly after his return, he had to deal with a sudden outbreak of rebellion at Easter in Ireland, principally in Dublin.

The rebellion was put down by military force under Sir John Maxwell; the ringleaders were tried by court-martial and shot, Casement, who had landed from Germany, was put on his trial for treason and hanged; the Chief Secretary, Mr. Birrell, and the Lord Lieutenant resigned; a commission was appointed to inquire into the causes of the insurrection (and, it may be added, reported that it was mainly attributable to weakness in administration); and in the middle of May Mr. Asquith went himself to Dublin with a view to arriving at some new arrangement for the future government of Ireland. On his return he told the House of Commons that he had been deeply impressed by the breakdown of the existing machinery, and by the universality of the Irish feeling that there was now a unique opportunity for a new departure. Accordingly he announced that ministers had unanimously commissioned their colleague, Mr. Lloyd George, to endeavour to effect a settlement. The announcement was favourably received, as

Mr. Lloyd George's good-will to Ireland was well known, and his reputation for getting work done had enormously increased since the outbreak of war. It was believed, moreover, that a Coalition would have a better chance than a party Government to arrange agreed terms. At first the negotiations appeared to promise well. Mr. Redmond told a meeting of the Irish Parliamentary party in Dublin on June 10 that Mr. Lloyd George's proposals were:—(1) to bring the Home Rule Act into immediate operation; (2) to introduce at once an Amending bill, to cover only the period of the war and a short interval after it, providing during this period for the retention of the Irish members at Westminster in full number, and of the six Ulster counties under the Imperial Government. Sir Edward Carson persuaded the Unionist Ulstermen to accept these terms, and Mr. Devlin obtained a vote in their support from the Nationalists of the six counties. But the growing body of Sinn Féiners regarded the negotiations with great disfavour; and, on the other hand, the Southern Nationalists protested, and many Unionists in Parliament and the Cabinet objected, Lord Selborne resigning his office in consequence. Lord Lansdowne explained that the Government were not bound by Mr. Lloyd George's consultations, and certain modifications were introduced in order to meet Unionist objections. The main alteration was that the Government could not agree to retain the Irish members at Westminster in undiminished numbers after the next election. The Government also proposed during the transition to appoint an Irish minister responsible to Parliament, having a military officer appointed with him with forces sufficient to maintain

order. These modifications were the reason, or the excuse, for Mr. Redmond to raise the cries of "coercion" and "breach of faith," and to withdraw from the negotiation; though Mr. Lloyd George, the Government negotiator, protested that in his opinion the terms were such as the Irish members might well accept. The negotiations having broken down, Mr. Duke, a Unionist, was appointed Chief Secretary, and a month later, Lord Wimborne, a Liberal, was reappointed Lord Lieutenant.

The summer of 1916 was marked by the sudden death of the great soldier upon whose experience and power of organization the majority of Britons at the outset of a war placed their special reliance. Lord Kitchener, on a mission to Russia, left the north of Scotland on June 5 in H.M.S. "Hampshire," which that evening struck a mine to the east of the Orkneys and sank. There were only 12 survivors, and he was not among them. His services, in the early days of war, were of incalculable value. If, subsequently, he had failed in some degree to adapt himself to his environment, nevertheless his disappearance was felt all over the world as a heavy blow to the Allied cause. Its effect was minimized, so far as might be, by the appointment to the Secretaryship of State in his place of the civilian minister who had shown the greatest energy and resource in the war, Mr. Lloyd George. Lord Derby, who had rendered exemplary services to recruiting, became Under-Secretary for War. At the same time, Sir Edward Grey, the trusted Foreign Secretary, whose eyesight had been failing, went to the House of Lords as Visct. Grey of Fallodon. He retained the Foreign Secretaryship, and had an efficient representative in the House of Commons in Lord Robert Cecil, at once his Under-Secretary and Minister of Blockade.

Public opinion in England was disturbed (his summer over many subsidiary matters relating to the war—the ill-treatment of British civilian prisoners at Ruhleben, and of British military prisoners in German camps, and the slight attention which the German Government paid to the reports of American diplomatic visitors and to British diplomatic representations; the increasing shortness of food, the difficulties of agriculturists whose labourers had been taken under the Military Service Acts and who had not been able as yet to obtain an adequate supply of capable women in their place, and the nearing prospect of rations; the judicial murder by the Germans of Capt. Fryatt, of the U.S. "Brussels," for endeavouring to ram a German submarine; and—what loomed largest in Parliamentary debate—the failure of British arms in two exclusively British theatres of action, the Dardanelles and Mesopotamia. The remaining troops had all been brought safely away from the Gallipoli peninsula in the winter of 1915-6, but the causes of the failure of a promising venture were still hotly disputed; in Mesopotamia, Gen. Townshend had been forced to retire before reaching Bagdad, had been besieged in Kut, and had finally, on April 29, been driven to surrender with all his force to the Turks. The Government resisted inquiry until public opinion proved too strong for them; but at the end of July two Royal Commissions were appointed; that for Mesopotamia under the chairmanship of Lord George Hamilton, a former Secretary of State for India; that for the Dardanelles under the chairmanship of Lord Cromer, the most venerated of British empire-builders.

Stirring events happened this spring and summer in the war nearer home. The German fleet ventured out into the North Sea, and, after being held and fought for several hours by Sir David Beatty and his battle-cruiser squadron, was brought to action by Sir John Jellicoe and the main fleet off the coast of Jutland, was severely handled, and only got back to harbour under cover of night. But British losses were serious, and many doubted whether the most had been made of a unique opportunity. Then the determined German attempt to take Verdun was resisted most heroically by the French in a fight lasting many weeks; and on July 1 the British army, partly with the view of relieving the pressure on its Allies, began a furious assault on the Somme, which, though successful

Cabinet and Dominion Promoters.

Rebellion in Ireland.

Mr. Lloyd George's Irish proposals.

Death of Lord Kitchener.

Dardanelles and Mesopotamia.

State of England.

and productive of glorious death; was terribly costly, and lasted till late autumn without breaking through the German lines.

In the midst of this long-drawn-out battle, Britain entered the third year of war, with ample indications from King, ministers, Empire and people that the struggle would be pursued without flinching. Votes of credit multiplied.

*A First to a Finish.*  
In May Mr. Asquith obtained one for £300,000,000; at the end of July another for £450,000,000; and in October yet another for £500,000,000. Mr. Lloyd George, who was felt more and more to incarnate the spirit which possessed the British people, told an American interviewer in September that the war could not be ended except by a complete victory. "The fight must be to a finish," he said; "to a knock-out." Lord Grey of Fallodon endorsed this opinion in October. There must be no peace, he said, except a peace which would ensure that Europe should henceforth live free from the shadow of Prussian militarism. And in November, in a telegram to Mr. Taft, on the occasion of a banquet in New York of a league to enforce peace, he expressed a sincere desire to see a League of Nations formed and made effective, to secure the future peace of the world—after the end of the present war.

Labour was restless this autumn. The railwaymen agitated for increased war bonuses, the South Wales section being particularly insistent, and made arrangements for a strike which was avoided by a doubling of the previous war bonus of 5s. in some cases and 2s. 6d. in others.

*Restiveness of Labour.*  
The Labour Congress in September was not particularly fruitful in suggestions; save that there was a call for a Labour Ministry. The coal-mining industry occupied much public attention. Mr. Asquith pointed out, at a conference of owners and men on Oct. 25, that the output had seriously fallen off, thus imperilling the supply of munitions. Avoidable absenteeism, the main cause, must be reduced; if not eliminated. Both masters and men promised co-operation. But serious trouble broke out in November in the South Wales coal-field, owing to demands for higher wages. The Government made a new regulation under the Defence of the Realm Act by which the Board of Trade were to have power to take over and work coal-mines. Under this they took over the South Wales coal-field, but found it necessary to grant an advance of 15% in wages.

The restiveness of Labour was largely due to difficulties about food. A Board of Trade Committee on food prices was appointed in June with Mr. J. M. Robertson as chairman; and, with its report before him, Mr. Runciman announced that the Government had determined to control the importation of wheat, by the agency of a Royal Commission, with Lord Crawford as chairman. They had already made a large purchase of Australian wheat. A week later he mentioned that the Government had spent altogether over £60,000,000 in the purchase of meat; and he explained that the bulk of the mercantile marine was remaining under Government control. But he declined the suggestions made by Mr. Barnes from the Labour side for appointing a Food Controller, or instituting bread tickets or coupons, or any system of rationing. A month later he announced that the Government had decided to appoint a Food Controller, that war bread would be instituted, that the Government would take drastic steps to deal with wheat and potatoes, that maximum prices would be fixed and that the amount of sugar issued would be seriously reduced. Another matter in which the Government were driven against their will to accept the view of the House, and especially of the Labour members, was the creation of a unified and comprehensive Ministry of Pensions, instead of adopting the middle course of a Pensions Board of inadequate scope.

*Food Difficulties.*  
But the principal preoccupation of a confused autumn was the constantly recurrent problem of man-power. The army authorities believed that many young men had managed illegitimately to escape the obligations of the Military Service Acts; and they tried for a time, with little success, the system of "rounding up" men of military age at theatres, railway stations, football fields, parks, and other places of public resort. A more legitimate demand was for the

*Problems of Man-Power.*  
"combing out" of suitable men from Government offices and in reserved trades; and a Man-Power Distribution Board was appointed, with Mr. Neville Chamberlain as chairman, which set about this necessary job. The question of raising the military age was considered by the War Office, but put aside for the moment. Arrangements were however made, by which a considerable number of suitable young men were released from civil occupations and drafted for military service. At the same time recognition was given to the new volunteers, elderly men who had come forward to perform such military duties in the Home defence of the country as their age and their disabilities permitted. The public in England and Scotland naturally resented the exclusion of Ireland from the Military Service Acts, and there was pressure for her inclusion, in which Irish Unionists joined; but Mr. Redmond declared that any project of the kind was insane. At the same time he attacked with some bitterness the system of Government in his country as entirely inconsistent with the principles for which the Allies were fighting in Europe. While ministers praised Mr. Redmond's labours for recruiting, they could not but acknowledge the poor contribution of Ireland in men to the war compared with the rest of the Empire.

As autumn passed into winter, and the prolonged Somme battle died down without the hopes with which it had begun having been realized, and news came that the Germans had overrun the new Ally of the Western Powers, Rumania, and occupied Bucharest, the irritation of ardent spirits against the delays and apparent want of efficiency of the Government gathered head. Criticism was largely focused upon what was considered to be the "wait and see" temperament of the Prime Minister. New blood was also demanded for the Admiralty, the public having been disturbed by the comparative success and immunity of a recent German destroyer raid in the Straits of Dover; and at the end of November it was announced that Adm. Jellicoe would come there as First Sea Lord, Adm. Beatty succeeding him in command of the Grand Fleet. This change was welcomed, but more was desired, and was loudly called for by a considerable section of the press, led by *The Times*. Mr. Lloyd George, who, within the Ministry, shared to the full the public desire for greater energy and coordination in the conduct of the war, recognized that this was the moment to enforce his ideas. He concentrated upon the point which had been treated as vital more than a year before by *The Times* and by competent critics in Parliament, the ultimate responsibility for the civilian day by day conduct of the war. The War Committee, at the moment, consisted of Mr. Asquith, Mr. Bonar Law, Mr. Lloyd George, Mr. Balfour, Mr. McKenna, Lord Curzon and Mr. Montagu. But it was merely a Committee of a Cabinet of 25 members, and was subject to the constant check and control of this miscellaneous and unwieldy body. On Dec. 1 Mr. Lloyd George, in a letter to the Prime Minister, demanded—and enforced his demand with a threat of resignation—a radical change of organization; namely that the conduct of the war should be placed in the absolute control of a small War Committee sitting daily and consisting of not more than four members, himself, Sir Edward Carson (a convinced supporter of an energetic policy), Mr. Bonar Law, and a Labour member. Mr. Asquith was pointedly omitted from the proposed body. He refused to agree, but determined, with the King's assent, to reconstruct his Government. Mr. Lloyd George endeavoured to build a golden bridge by consenting to admit the Prime Minister as a consultative and advisory member of the Committee, with the power of ultimate reference to the Cabinet. Mr. Asquith at first assented, but on second thought refused. After all, the essence of the scheme was that Mr. Lloyd George, with a very limited council of advisers, should direct the war, rather than Mr. Asquith. On Mr. Asquith's refusal, Mr. Lloyd George resigned, on Dec. 5. The defection of the most powerful man in the Ministry made it impossible for Mr. Asquith to continue, and he too resigned. The King sent for Mr. Bonar Law, the Unionist leader, but Mr. Law could not secure Mr. Asquith's

*Discontent with the Ministry.*  
Mr. Lloyd George's Demand.

*Mr. Lloyd George's Demand.*  
Parliamentary Crisis, 1916.

Digitized by Google

cooperation, and also considered that Mr. Lloyd George had shown the qualities which the nation wanted at this critical period. So the commission passed to Mr. Lloyd George, the statesman whose reputation had steadily grown throughout the world conflict, who had already played such a decisive part, as Chancellor of the Exchequer, Minister of Munitions, and Secretary of State for War, and who more than any of his colleagues embodied the will to victory of his countrymen.

Mr. Lloyd George was assured of the close cooperation of Mr. Bonar Law, and of the united support of the Unionist party. He set great store upon the help of the Labour party, one of whose members, in his view, ought to sit on the small Committee or Council directing the conduct of the war. Meetings of the Parliamentary Labour party and the National Executive were held, at which, on the advice of all the labour members who had been ministers in the First Coalition and of the chairman of the party, it was decided by a majority to take part in the new Government—a decision which was ratified by the annual Labour Party Conference in the following month. The action of the Liberal party was thought at first to be doubtful, because Mr. Asquith, and all his principal Liberal Cabinet colleagues, such as Lord Grey of Fallodon, Lord Crewe and Mr. McKenna, refused to serve under Mr. Lloyd George. But the Liberal War Committee pledged itself at once to active support; the Welsh Liberal members rallied in a body to the side of the Welsh Prime Minister; and a party meeting at the Reform Club, following the advice of Mr. Asquith, recorded its determination to give support to the King's Government engaged in the effective prosecution of the war. Mr. Lloyd George and Mr. Bonar Law, therefore, had a wide field of selection, only Mr. Asquith and his immediate friends, and Lord Lansdowne, who took the occasion to retire, being ruled out.

Having a free hand Mr. Lloyd George carried through an even more revolutionary change than that which he had submitted to Mr. Asquith. He constituted a small Cabinet of four members, who were relieved entirely of serious departmental duties, who were to sit daily, and to concentrate themselves upon the war, of the conduct of which they were to have absolute control. He himself, as Prime Minister, was the chairman of this War Cabinet; and, in order to perform this his main duty satisfactorily, he devolved the leadership of the House of Commons upon Mr. Bonar Law, who was indeed already the leader of the largest numerical section of its members. Mr. Law also became Chancellor of the Exchequer, and was an additional member of the War Cabinet, but was not expected to attend regularly. The Prime Minister's three regular Cabinet colleagues were Lord Curzon, who became Lord President of the Council and leader of the House of Lords, had two ministers without portfolio, Mr. Henderson, the Labour leader who had held high office in the first Coalition, and Lord Alden, the only statesman of marked administrative ability and experience who had not joined that Coalition. It was right to turn, at this critical moment, to the man who had borne the civil responsibility in the last British war, that with the Boers; and from this time onward Lord Milner's share in the conduct of the war from the British side was second only to Mr. Lloyd George's. The War Cabinet sat daily in Whitehall Gardens, having Sir Maurice Hankey, the secretary of the Committee of Imperial Defence, as its secretary, with a competent staff under him. Other ministers were summoned to its deliberations, whenever those concerned the departments for which they were responsible.

The one serious loss which Great Britain suffered through Mr. Asquith's resignation was that of the Foreign Secretary, Lord Grey of Fallodon, who had conducted the external affairs of the country, with increasing reputation and success, for 11 years. It was vitally important for Mr. Lloyd George to secure, as Lord Grey's successor, a statesman in whose character and record the Allies could have full confidence. He was fortunate in obtaining Mr. Balfour's consent to accept an office with whose work he had become familiar when acting Secretary of State in Lord

Salisbury's absence. For the other important posts in his Ministry Mr. Lloyd George relied very largely upon the services of business men and experts, hitherto in many cases outside politics and the Houses of Parliament, of whose aid he had made such excellent use in developing munitions. The country saw with satisfaction the Board of Trade entrusted to Sir Albert Stanley, who had previously directed the Underground railway and the motor-omnibus system; the Board of Education to Mr. H. A. L. Fisher, the Oxford scholar and historian, vice-chancellor of the university of Sheffield; the Local Government Board to Lord Rhondda, the South Wales colliery magnate; and the Board of Agriculture to Mr. R. E. Prothero (afterwards Lord Esmé), M.P. for Oxford University, who had managed for many years the vast agricultural estates of the Duke of Bedford. For the more efficient conduct of the war, five new ministries were created—Air, Labour, Pensions, Food Control, and Shipping Control—for two of which, Pensions and Food Control, some inchoate provision had been made in the last weeks of the first Coalition Ministry. Lord Devonport, who had large experience in the grocery business, became Food Controller; Sir Joseph Maclay, a Glasgow ship-owner, was appointed Shipping Controller; the new Air Board was constituted with Lord Cowdray, the head of a great firm of contractors, as president; while Labour and Pensions were fittingly assigned to two outstanding Labour members, Mr. Hodge and Mr. George Barnes. Seats were found in the House of Commons for Sir Albert Stanley and Mr. Fisher; but Sir Joseph Maclay preferred to work outside Parliament, and his office was represented in the House by Sir Leo Chiozza Money, the parliamentary secretary. Where Mr. Lloyd George appointed experienced parliamentarians to office, he chose those who had shown special keenness in the prosecution of the war. Then Sir Edward Carson went to the Admiralty; Lord Derby to the War Office; Mr. Walter Long to the Colonial Office; Dr. Addison to the Ministry of Munitions; and Sir Frederick Crawley, chairman of the Liberal War Committee, to the Duchy of Lancaster. Mr. Chamberlain remained Indian Secretary, Lord Robert Cecil Minister of Blockade, Mr. Duke Irish Secretary and Sir F. E. Smith Attorney-General, Sir Gordon Hewart becoming Solicitor-General in the place of Sir George Cave, who went to the Home Office. Sir Robert Finlay, who had been Attorney-General in 1906-8, was made Lord Chancellor as Lord Finlay. There were joint parliamentary secretaries to the Treasury, Lord Edmund Talbot (afterwards Lord Fitzalan), and Hon. Neil Primrose, Lord Rosebery's son.

In addition to these appointments, Mr. Lloyd George announced, in his statement on Dec. 19 of the policy of the new Government, that the time had come for complete mobilization of the labour reserves, and therefore the Cabinet had adopted the principle of universal national service, and had appointed Mr. Neville Chamberlain, Lord Mayor of Birmingham, Director-General of National Service. He would schedule all industries, and set labour free from non-essential industries, so as to be available for war and for essential industries. The new Prime Minister also announced that the Government would take complete control of all ships and of the whole mining industry. There must also, he said, be real sacrifices made in the matter of food. Every available square yard must be made to produce; and as to luxuries and indulgences there must be a national Lent. These expectations were supplemented by Mr. Prothero, the Minister for Agriculture, who said that the War Office and the country must realize that Britain was as beleaguered a city, and that victory might well be lost or won on her own fields and potato lands; and by Lord Devonport, the Food Controller, who pushed further the restrictions which Mr. Runciman had already enforced, limited dinners to three courses and luncheons to two courses in all public eating places, and hinted at rationing as the only way of ensuring that unpatriotic people did not get supplies in excess of their wants. In another direction the Government developed boldly a policy tentatively adopted by their predecessors. The Colonial Secretary summoned immediately by cable the Prime Ministers of the self-governing dominions to a special war conference of the

Mr. Lloyd George, Prime Minister

Labour's Place in the Coalition

War Cabinet

Statements of Policy

Empire, explaining that they would for the purpose of these meetings be members of the War Cabinet, and to be directly responsible for the conduct of hostilities. The enormous share which the colonial forces had taken in military action by land and sea fully justified this development.

The public were gratified by the evidences of energy and resolution shown by the new Government. Mr. Asquith, though he took his seat on the front Opposition bench, protested that he did not appear as leader of an Opposition, or even of the Liberal party, but would give his successors the benefit of his experience. The Government had to deal immediately with a peace offer from Germany, based on the assumption that the Central Powers had won considerable successes and could not be defeated. If the Allies would negotiate on these assumptions, Germany would bring forward peace propositions; if not, the Central Powers were resolved to carry on the war to an end, "while solemnly disclaiming any responsibility for this before humanity and history." Mr. Lloyd George at once in Parliament said that it was necessary to know whether Germany was prepared to accept the only possible terms which the Allies could offer—namely restitution, reparation and guarantee against repetition. The formal reply to the Central Powers was based on this idea, and treated the German offer as empty and insincere.

Before this reply had been drafted, Mr. Woodrow Wilson, who had been re-elected President of the United States in the previous month as the man who had kept his country out of the war, addressed a Note to the belligerent Powers suggesting that they should issue a statement of their war aims—which, he somewhat strangely asserted, seemed to be much alike on both sides. Though

this intervention was not welcomed in England any more than on the continent of Europe, the Allies sent in Jan. 1917 a courteous answer, explaining in some detail their objects of restoration and liberation, while the Central Powers merely expressed their readiness to enter a peace conference.

It soon became evident that the peace manoeuvres of the German Government were put forward in order to obtain an excuse for entering upon that indiscriminate submarine warfare on which their most active naval and military leaders were coming to base their main hope of success. The new system was put in force at the beginning of February. The German Government notified that they would regard all the waters surrounding the British Isles and the whole of the northern and western coasts of France, as well as the eastern Mediterranean, as barred zones within which German submarines would sink all ships at sight; save only that one passenger steamer would be allowed each way weekly between America and Falmouth, and one paddle-steamer daily between Flushing and Southwold. While this policy of desperation brought the United States within a couple of months into the war, it undoubtedly created a very serious situation for the Allies—especially for Great Britain, though it never deterred British ships or British sailors from sailing. The Prime Minister spoke early in February at Carnarvon of the "great and growing menace of German piratical devices"; at the opening of Parliament on Feb. 7, Mr. Asquith denounced the new warfare as "a declaration of war against humanity," and Mr. Bonar Law warned the House of Commons that the country had reached the very crisis of its fate.

The note of sacrifice, which Mr. Lloyd George said had hitherto been confined too much to the trenches, was sounded loudly in Great Britain from the very beginning of the year. From Jan. 1 train services became much slower and less frequent than before, while the fares were raised 50%; and from the same date it became compulsory to bake standard bread in which the proportion of wheat-flour was comparatively small. Prices were fixed at once for wheat, oats and potatoes, and a little later for tea, coffee, bacon, butter, cheese and lard; the amount of beer to be brewed was considerably reduced, so as to economize barley, sugar, tonnage, transport, labour and fuel. Lord Devonport, in view

of the urgent necessity for some curtailment of the nation's food consumption, issued on Feb. 2 a scheme for voluntary rationing; he called upon heads of families to limit their weekly purchases to the following quantities: *Voluntary Rationing*  
for each person comprising the household: bread 4 lb., meat 2½ lb., sugar ½ lb. The King at once put himself and the Royal family and household on rations; and his example was widely, but far from universally, followed in the country. The attempt to limit consumption by prescribing the number of courses at meals in public eating-places proved a failure, and a new order was issued in April, providing for a weekly meatless day, for five days without potatoes, for rationing bread and meat by bulk on a scale which allowed 2 oz. of bread for each meal, 2 oz. of meat at breakfast, and 5 oz. at lunch or dinner; but the order did not apply to any public eating-places where the charge for a meal, exclusive of drinks, did not exceed 1s. 3d. Orders were issued restraining food hoarding, the making of rich pastry, and the undue consumption of food at afternoon tea. Apart from the submarine depredations, the harvest of two essential crops, wheat and potatoes, had failed in a greater or less degree, this year throughout the world. With regard to potatoes, Lord Devonport asked people who could afford substitutes, such as rice or swedes, to use them, so as to prolong the supply of potatoes for the poor; and Mr. Prothero urged that every village and small town should make itself self-sufficient with regard to potatoes. With regard to wheat and flour, it was ordered that bread should be sold only by weight and must be at least 12 hours old; maximum prices were fixed for home-grown wheat, barley and oats; the use of wheat, rye and rice for any other purpose except for human food was prohibited; importation of feeding-stuffs for cattle was limited; and power was given to the Food Controller to take over the flour-mills and issue regulations for their management. Mr. Prothero, in order to stimulate food production at home, made arrangements for turning German prisoners and a large supply of women on to the land.

But the main contribution of the Minister of Agriculture to native food supply was a Corn Production Bill, which was calculated to turn pasture into arable land on a large scale: It provided for the payment of a bounty to the occupier of any land on which wheat or oats were produced, if the average price of wheat or oats should fall below a certain minimum. A minimum wage of 9s. was also to be secured for agricultural labourers, landlords were restrained from raising rents in consequence of the necessity, and powers were given to the Board of Agriculture to enforce proper cultivation and to take possession of untenanted land. In introducing the bill Mr. Prothero said that, with three-fifths of the total cultivated area under the plough, the nation would be free of the nightmare of the submarine menace. Under the bill the State would go into partnership with the agricultural interest, and stand security against loss. So complete a breach with the Victorian attitude of *laissez faire* towards agriculture could not, of course, pass without challenge from rigid free traders like Mr. Runciman. But the second reading was carried by 283 to 27; and in committee an attempt by the Labour party to raise the minimum agricultural wage from 2s. to 30s. was rejected by 302 to 102. When the bill reached the House of Lords, it met with the approval of Lord Lincolnshire, both an eminent free trader and an expert agriculturist, and duly became law. At the beginning of the session of 1918 Mr. Prothero testified to the patriotic way in which landowners and farmers were ploughing up grasslands and taking advantage of the Act. Besides these measures of Lord Devonport and Mr. Prothero, steps were taken to save tonnage by prohibiting or restricting the import of non-essential articles, notably alcoholic liquors, timber and paper.

Such were the precautions taken to economise food and tonnage, and to stimulate production. The measures employed by the Admiralty to meet the menace included the establishment of a large new minefield in the North Sea; the arming of merchantmen as rapidly as possible; and the appropriation of the shipbuilding programme mainly to making good the losses in the mercantile marine. An anti-

submarine department was also set up; composed of the most experienced men serving at sea, who invited suggestions from any sailor in the fleet. Then there was the Board of Inventions, presided over by Lord Fisher, and containing some of the greatest men of science in the country: But Sir Edward Carson, the First Lord, did not claim that any certain remedy had been found. The figures proved this only too clearly. In the first three months of unrestricted submarine warfare, Great Britain lost nearly 1,300,000 tons of shipping (out of a total of some 20,000,000 tons of which 2,000,000 tons were being used for war purposes), and April, the last of these months, was the worst of them all. In one week alone of April 24 British vessels of over 1,600 tons and 16 under that tonnage were sunk.

These alarming figures naturally suggested the advisability of compulsory rationing, and both in the press and in Parliament there were loud calls in May for its immediate institution. Lord Milner told the House of Lords that the Government would only resort to it if convinced of its absolute necessity, but that meanwhile they were studying the various methods of rationing. The returns of shipping losses during May and subsequent months, though grave enough, showed a marked improvement on the April record, and the Food Ministry stated that the prospect of compulsory rationing was steadily receding. But people were worried by the shortness of food, especially bread, sugar and milk, which led to queues at shops, by the high prices especially of meat and by the uncertain policy of the Food Controller. He instituted a campaign to explain to people why they should eat less bread and meat. He asked people to give up the use of starch. But he was slow to fix retail prices, and a cry arose that he allowed the public systematically to be robbed by profiteers owing to his inaction. Steps were eventually taken in June to curb speculation in food, by prescribing that meat salesmen should sell only to retail butchers or consumers, and that the prices charged on reselling should not exceed a certain maximum. More confidence was felt in the Food Ministry when in the middle of June Lord Devonport resigned the controllership owing to unsatisfactory health, and Lord Rhoads, whose reputation for getting things done had been increased at the Local Government Board, was prevailed upon to accept the post.

Mr. Neville Chamberlain's proposals for national service were formulated in February. The object was to secure substitutes to replace the men taken for active service, and to draft labour from unessential to essential trades. He called for volunteers from men between 18 and 60, asking willing workers to enter their names on a register; and the Government introduced a bill establishing a Ministry of National Service. The bill was not, however, well received; the Labour party were afraid lest industrial conscription should be introduced by a sidewind; and the whole scheme proved somewhat abortive. But the need of the army for more men was urgent, and the Government introduced towards the end of March a new Military Service bill, providing for a fresh examination of discharged and rejected men; the authorities hoped by this means to secure 100,000 fresh recruits in three months. Drastic as this measure was, Lord Derby in the House of Lords said that larger measures would be necessary.

The new Chancellor of the Exchequer, Mr. Bonar Law, lost no time in making a further effort to raise money on a large scale for the war. At a great meeting at the Mansion House on Jan. 5, with the Prime Minister by his side, he announced the conditions of a new loan. It was to be a 5% Government stock issued at 95, and arrangements were made for converting previous war issues into the new stock. The lowest individual sum accepted would be £50, or £5 through the Post Office, and bankers would give facilities to their customers to subscribe. There was also a tax-compounded 4% loan to be issued at par. The new loan was a great success, yielding over a thousand millions sterling subscribed for by five and a quarter million people. The money was badly needed, as the expenses of the war were mounting rapidly. Mr. Law obtained a vote of credit in December 1916 for £400,000,000,

and on Feb. 22, 1917 (two votes of credit amounting together to £550,000,000, the largest sum ever asked hitherto at a single sitting in the financial history of the country. He told the House that the average daily cost of the war had risen to £3,500,000. It is not surprising that in these circumstances, and with the enormous development of Government offices and staffs, there should have been an outcry in Parliament against what Lord Middleton called an uncontrolled orgy of expenditure. But, in spite of protest, the expenses continued to mount. Before the introduction of the budget, Mr. Law had to obtain in March a further vote of credit for £60,000,000 to meet unforeseen items of expenditure. In the budget he proposed no new taxation, but increased the entertainments tax and the tobacco duty, and raised the excess-profits duty from 6s to 8s per cent. He explained that 26% of the war expenditure had been provided out of revenue. Immediately after the budget, on May 9, he came once more to the House of Commons, this time for a vote of credit of £500,000,000; and on July 24 the largest vote of all, £650,000,000, had to be obtained, and it was recognized in debate that the country was rapidly reaching the limit of its possible expenditure. Two more votes, for £400,000,000 in September, and for £550,000,000 in December, were needed before the end of the year. In this autumn, Mr. Law put "on tap" an entirely new form of "continuous" loan, unlimited in amount, in the form of national war bonds, bearing interest at 5%, and 4% free of income tax. By Jan. 12, 1919, £1,446,625,623 of these bonds had been sold, and nearly £90,000,000 of small post-office bonds had been subscribed for. It may be mentioned that the pressure of the war was shown this year to have broken down many cherished financial prepossessions. The passage of the Corn Production bill has been already mentioned. A committee on commercial and industrial policy, of which Lord Balfour of Burleigh, a life-long free trader, was chairman, recommended in February: (1) the taking of special steps to stimulate, where economically desirable, the production of food-stuffs, raw materials and manufactured articles throughout the Empire; (2) the adoption of Colonial Preference; and (3) the establishment of a wider range of customs duties. Moreover the Government of India, in spite of determined opposition from Lancashire, increased, and was supported by the Government at home and by the House of Commons in increasing, for revenue purposes, the import duties on cotton, without imposing any countervailing excise.

These tendencies were accentuated by the proceedings of the Imperial War Cabinet and Imperial Conference. The Imperial War Cabinet began its sittings in March, the Prime Ministers of Canada, S. Africa, New Zealand and Newfoundland and the Secretary of State for India (advised by Indian and Anglo-Indian councillors) sitting, along with the British Prime Minister and the members of his War Cabinet, to determine matters essential to the conduct of the war, as well as to consider Imperial policy in regard to terms of peace. Mr. Hughes, Prime Minister of Australia, was unfortunately detained at home by political complications. Sir Robert Borden explained, in a speech on April 2, that the various Prime Ministers met in the Imperial War Cabinet as equals, though the British Prime Minister presided, *primus inter pares*. Each nation of the Empire thus had its voice upon questions of common concern, while preserving perfect autonomy. "For many years the thought of statesmen and students in every part of the Empire has centred round the question of future constitutional relations. It may be that now, as in the past, the necessity imposed by great events has given the answer." At the end of April Mr. Bonar Law announced in the House of Commons that the Imperial War Cabinet had accepted the principle of Imperial Preference; but there was no intention of making any change during the war, nor did it involve the taxation of food. Mr. Lloyd George, when receiving the freedom of the City of London, said at the Guildhall that one of

More Food Control.

Military Service Bill of 1917.

War Loan of 1917.

Mr. Law's First Budget.

National War Bonds.

Modification of Free Trade.

Imperial War Cabinet, 1917.

Imperial Preference.

the first duties of statesmanship would be to develop the Empire. The sittings of the Imperial War Cabinet lasted till May 17, and Mr. Lloyd George told Parliament that the experiment had been a complete success. At the last session, on his proposal, it was agreed that meetings of an Imperial Cabinet should be held annually, or at any intermediate time

when matters of urgent imperial concern had to be settled. Accordingly another session of the Imperial War Cabinet was held in the summer of 1918, lasting from June to August, when there was a full attendance. It was decided that for the future the Prime Ministers, as members of this Cabinet, should have the right of direct communication with the Prime Minister of the United Kingdom; and that each Dominion should have the right to nominate a visiting or resident minister in London to be a member of this Cabinet at meetings, to be held at regular intervals, other than those attended by Prime Ministers.

Each of the two years, simultaneously with the Imperial War Cabinet, an Imperial Conference, of which the membership embraced other representatives of the various Empire nations besides the Prime Ministers, sat under the presidency of the Colonial Secretary. In 1917 the Conference recommended that a special Imperial

Conference should be called to deal with the future constitutional relations of the Empire as soon as possible after the cessation of hostilities, couching its recommendations, however, in such terms as to preclude the setting up of an Imperial Legislature or an Imperial Executive. In 1918 the principal recommendations all related to economic questions. The Conference endorsed the principle of a Non-Ferrous Metal Industry Act which the British Government, in spite of determined Free Trade opposition, had passed in the winter, in order to eliminate enemy influence in Great Britain from the control of such metals and ores as zinc, copper, tin, lead, nickel and aluminium, and made dealing in such metals without a Board of Trade licence unlawful until five years after the war. The other Governments of the Empire were advised to free themselves in similar fashion from dependence on German controlled organizations in respect of these metals. The Conference also recommended that the Governments should secure the command of essential raw materials produced within the Empire so as to repair the effects of war and safeguard industrial requirements, and should make arrangements with Allied Governments in order to utilize the raw materials produced in Allied countries. A further resolution recommended the appointment of a committee to consider the possible methods of obtaining such command of raw materials, and consultation with producers and merchants concerned in each commodity. Mr. Lloyd George and Mr. Bonar Law endorsed these resolutions in speeches to a deputation of manufacturers on July 31 1918. The former said that under no conditions must industries essential from the point of view of national defence and security be let down in the future; the latter, that an immense move forward had been made in the whole conception of British trade policy, the principles of a common Empire and of preference within the Empire being established.

Outside the submarine menace there were some cheering symptoms in the military situation in the spring and summer of 1917. The retreat in February of the German troops in France from the lines they had held since the autumn of 1914 to the Hindenburg line, the considerable captures of prisoners and guns by British troops in the battles of Arras in April, of Messines in June, and of Third Ypres in July, and Sir Stanley Maude's victorious advance to Bagdad in March, confirmed the confidence of the British people in the efficiency of their new armies. Above all, the entry of America into the war was hailed with welcome and relief in Great Britain. As the Prime Minister said, the advent of the United States made it clear to the world that "this is no struggle for aggrandizement and for conquest, but a great fight for human liberty." Mr. Balfour went across the Atlantic on a mission to arrange for common working; and the services of the British navy were placed at the disposal of the United States

*Entry of America into the War.*

for the convoy of troops. It was felt that, if the Allies could hold out sufficiently long, which there was no reason to doubt, the numbers and wealth of the United States must finally turn the scale against the Central Powers. One immediate advantage of American belligerency was the removal of the last obstacle to a stringent blockade of Germany, and Lord Robert Cecil could claim this spring that there was now a complete cessation of overseas importation into enemy countries.

The Russian Revolution, which began in March, was also hailed at the time in England as a favourable portent for the Allies. It was said, said Mr. Lloyd George, the sure promise that the Prussian military autocracy would, before long, be overthrown. But, as a matter of fact, from the first days of the revolution, there was an informal armistice and overtures for fraternization on the eastern front, and an attempt by Gen. Brusilov to renew fighting in July and August came to an end before long through the spread of insubordination. Thenceforward it was realized that the Germans would be able to transfer almost the whole of their forces hitherto in the east to the west, and that in consequence the task before the British army had become appreciably heavier. The revolution had also an unsettling influence on British workmen, already showing symptoms of restlessness under the strain of war. There was in March a serious strike of engineers at Barrow, disapproved by their union, but organized by shop stewards, which collapsed after a fortnight only on the threat of the Government to use their powers under the Defence of the Realm Act. Another unauthorized strike of engineers took place in S. Lancashire in May, largely as a protest against dilution; and there was trouble in other trades and in other parts of the country. In August a railway strike was threatened, owing to long hours and overwork, but was abandoned on a promise by the Government to continue the control of railways for a time after the cessation of hostilities, and meanwhile to do their best to secure a shorter working-day. A further railway crisis occurred in November, about wages, resulting in an advance estimated to cost the companies £9,500,000 a year. To set against these unsatisfactory features, there was published in June the Whitley Report, so called because the chairman of the Reconstruction Committee which compiled it was the then Chairman of Committees of the House of Commons, afterwards Speaker. This recommended the setting up of Joint Industrial Councils of masters and men in each industry, to settle all points of difference and wages and management. Such councils were set up in many trades, with beneficial results.

*Russian Revolution.*

*Strike at Barrow 1917.*

*Whitley Report.*

The features in the Russian Revolution which attracted a section of British working-class opinion were the war aims put forward by the Socialists, "No annexations and no indemnities," and the power obtained by the Soviets, or workmen's committees, culminating in a Soviet Government in October. In answer to pacifists in the House of Commons Lord Robert Cecil explained that imperialistic aims based on force and conquest were absent from the British programme, but that, in view of Armenia, the German African Colonies, Poland, Alsace-Lorraine, and Italia Irredenta, it was impossible to accept the programme of "no annexations," and in view of the war damage in Belgium, Serbia, and northern France, and of the destruction of merchant vessels, that of "no indemnities" was equally out of the question. The Independent Labour party in a conference at Leeds took up an attitude of sympathy with the Russian position, and advised the formation of Soviets in England. A large section of Labour opinion, comprising both moderates and extremists, desired that, in accordance with the wish of the Russian Socialist Government, English Labour should be represented at a conference, at which German representatives would be present, to be held at Stockholm at the instance of the International Socialist Bureau. But the Seamen's and Firemen's Union, which had suffered heavily through Germany's outrageous policy at sea, refused to carry the delegates; and neither American, Belgian nor French representatives would appear. The

*Russia and War Aims.*

*Stockholm Conference.*



only result of the movement was that Mr. Henderson, who had been active in its promotion, had to resign his seat in the War Cabinet. Even the Trades Union Congress at its annual meeting in September declared by an overwhelming majority against an International Conference at Stockholm "at the present moment." But before the end of the year the Labour party, suspicious of militarist or imperialistic designs among the Allies, drafted on its own account a statement of war aims of a somewhat idealistic character, demanding in particular the establishment of a league of nations, a demand which Lord Robert Cecil welcomed on behalf of the Government.

During this autumn the Labour party also busied itself with a reorganisation of its constitution, which was to transform it from a federation of Labour and Socialist societies into a national democratic political organization open to every worker who laboured "by hand or brain." The work was completed during the winter, and the new constitution was adopted in March 1918. The aim was, by forming local associations, and by appealing to middle-class workers and to the newly enfranchised women, to secure sufficient support from the electorate to warrant the hope of a Labour Government in power before many years. The new Labour party, thus constituted, held its first annual meeting in London in June 1918, promulgated a comprehensive socialist programme, and in spite of the protests of Labour ministers, determined no longer to recognize the political truce, though it did not insist that these ministers should withdraw from office so long as the country was at war.

The increasing defestation of the Germans, which was inspired by their merciless submarine campaign and by their recurrent air-raids, insured a warm welcome for certain measures which the King took in the summer of 1917, for dissociating the royal family from German connections. In June he decreed that those princes of his family who were his subjects and bore German names and titles should relinquish those titles and adopt British surnames. Accordingly the family of Teck became that of Cambridge and that of Battenberg Mountbatten, and the following peerages were conferred: the Duke of Teck, Marquess of Cambridge; Prince Alexander of Teck, Earl of Athlone; Admiral Prince Louis of Battenberg, Marquess of Milford Haven; Prince Alexander of Battenberg, Marquess of Carisbrooke. In July the King abandoned all German titles for himself and family, and issued a proclamation that his house and family should henceforth be known as the house and family of Windsor. The King also heartened the munition workers of Lancashire and Cheshire, and the shipping and engineering workers of the Clyde district by making tours among them, and he paid a visit in the summer, not for the first time, to the Grand Fleet. He instituted, moreover, two new orders—the Order of the British Empire, and the Order of Companions of Honour.

The reports of the Dardanelles and Mesopotamia Commissions were published, the one in the spring, and the other in the summer, of the year 1917, and the revelations they contained of mismanagement and middle in high quarters confirmed the public in its satisfaction that the two War Administrations presided over by Mr. Asquith had given way to Mr. Lloyd George's War Cabinet. The report of the Mesopotamia Commission, with its reflections on the Government of India, brought about Mr. Austen Chamberlain's resignation of the Secretaryship of State for India. Other ministerial changes took place about the same time. Lord Rhondda succeeded Lord Duxton as Food Controller, Sir Auckland Geddes succeeded Mr. Neville Chamberlain as Director of National Service, Mr. Barnes succeeded Mr. Henderson as Labour representative in the War Cabinet, Sir Edward Carson left the Admiralty to become a member of the War Cabinet without portfolio—a position from which he resigned in January 1918. Sir Eric Geddes became First Lord of the Admiralty, Dr. Addison Minister of Reconstruction without portfolio, Mr. Hayes Fisher (afterwards Lord Downham) President of the Local Government Board, Mr. Hodson Minister of Pensions,

and Mr. C. H. Roberts Minister of Labour. Mr. Lloyd George took the opportunity to bring back into high office his friend Mr. Churchill, and to attract to his banner Mr. Edwin Montagu, one of the ablest of the younger Liberals. Mr. Churchill became Minister of Munitions, and Mr. Montagu Secretary of State for India. Mr. Lloyd George also persuaded Gen. Smutt to remain in England as a regular member of the War Cabinet.

Several of these appointments had a special interest. The public looked askance at the return to office of Mr. Churchill after his responsibility for the Dardanelles fiasco; but Mr. Lloyd George had a high opinion of his friend's energy and capacity in office, and realized the inadvisability of leaving him to become the nucleus of a critical and aggressive opposition. Mr. Montagu took office with a mission to satisfy, so far as might be possible, the aspirations of a large body of Indian opinion after a wide measure of self-government. He visited India in the winter of 1917-8, and drew up in conjunction with Lord Chelmsford, the Viceroy, a report on Indian Constitutional Reform—published in the summer of 1918—which was well received in the House of Commons, but which was met with considerable criticism in the Lords, where the appointment of a joint committee to consider it was rejected by a majority of only four. Dr. Addison's appointment as Minister of Reconstruction showed a laudable desire on the part of the Government to be prepared for the end of hostilities, which might come with little warning. So zealously did he work that he was ready to announce, the day after the Armistice in Nov. 1918, the plans of the Government for demobilization, for the resettlement of officers and men in civil life, and for the reestablishment of industry on a peace basis. His main expedient for tiding over a difficult time was the establishment of an out-of-work donation—to be in operation for six months for civil workers and for twelve months after demobilization for soldiers. The advent of the brothers Geddes to Cabinet rank was due to admirable administrative work done by Sir Auckland under the War Office, and by Sir Eric both under the War Office and in the Admiralty. Sir Auckland changed Mr. Neville Chamberlain's original scheme of national service, which had involved somewhat elaborate office expenses and had produced only moderate results. He saved some £100,000 a month by reducing the expenses of a central office, and worked instead through employment exchanges, trade unions and societies of employers, federations. He effected a drastic comb-out of civilians, card-indexed the whole of the army at home, transferred workers from luxury trades and occupations to essential industries, and recruited a further large supply of female labour.

Sir Eric Geddes went to the Admiralty to complete and work a reorganization which his predecessor (Sir Edward Carson) had initiated, when in May a new naval war staff was constituted, the First Sea Lord, as chief of the staff, was freed of all administrative detail in order that he might give his undivided attention to questions of policy and strategy, and he had the assistance of a director of operations, a director of intelligence, and others. There was also revived the office of Admiralty Controller, who was to organize the whole of the supply of the navy including transport, victualling, manufacture of ordnance, and shipbuilding. Sir Eric had then been brought in from the outside to fill this important post, as a great civil administrator who had just successfully organized the military railway system behind the Allies in France, and in July, when Sir Edward Carson's vigorous counsel was needed in the War Cabinet, he became himself First Lord. The two main tasks of the Admiralty under him were to defeat the submarine menace, and to stimulate shipbuilding. They were more successful in the first than in the second. By provision of various ingenious methods of attacking and destroying underwater vessels they steadily reduced the losses of British ships, and they were able to announce the details of some 250 German submarines destroyed. But in spite of obtaining the assistance of Lord Pirrie, the great Belfast shipbuilder, as Controller-General of Merchant Shipbuilding,

ing, and of the institution of national shipyards, they were unable to do the last month of the war to make shipbuilding overtake ship destruction. The destruction of British ships in 1917 amounted to a tonnage of 4,000,537, and the ships built only reached a tonnage of 5,103,474. In the first nine months of 1918 the figures were: tonnage destroyed 7,925,512; built 1,310,741. In Dec. 1917, Sir Rosslyn Wemyss became First Sea Lord.

In 1917 German air-raids on England, especially on London, took a new form. They were carried out mostly by aeroplanes of a greatly enlarged type; and on the first two occasions, on June 15 and July 7, a fleet of these new vessels bombarded with some effect the East End and the City of London in business hours to broad daylight. Subsequent raids, which began early in September and continued at fairly frequent intervals throughout the winter, were, owing to improved defences, carried out by night, with comparatively slight damage and casualties. The enormous development of aerial fighting determined the Government in October to transform the Air Board into a Secretaryship of State for Air, and a bill was introduced and carried for that purpose. The Prime Minister invited Lord Northcliffe to become the first Secretary of State, but he declined, and his brother, Lord Rothermere, was appointed.

Such was the vigour of the Government that, despite the exacting cares and anxieties of the war, they were able to grapple with, and in two cases temporarily to solve, three questions about which there had been acrimonious party differences for many years. They introduced and passed both a comprehensive Reform Bill and also a comprehensive Education Bill; and they made a laudable but unsuccessful effort to get the Irish question solved by means of a representative conference of Irishmen sitting in Ireland. It became clear from the debates on a special Register Bill which Mr. Asquith's Coalition Ministry introduced in 1917 that there was a general desire for a further Reform Bill and a good deal of agreement as to its nature. The Speaker, accordingly, with the goodwill of the Government and the House of Commons, collected a committee of abolition peers and members of Parliament, some 30 in number, representative of all shades of political opinion, to discuss and report on the question of electoral reform. The report unanimously recommended the reduction of the qualifying period for registration as a Parliamentary elector from twelve months to six, and a revision of the register twice instead of once a year, and the substitution, for all existing franchises, of two simple ones, residence and occupation of business premises. Moral voting was to be abolished, save that a man might vote for his place of business or his university, as well as his residence. Proportional representation was recommended in the case of two member boroughs. By a majority, woman's suffrage was recommended to be exercised by every woman over a certain specified age, who, or whose husband, was on the Local Government register. As regards redistribution, a population of 20,000 was suggested as the standard unit for each member of Parliament. The report was well received, and a bill on the lines therein laid down was read a second time in May by 379 votes to 101.

The Government left the questions of proportional representation and of woman's suffrage in regard to which the qualifying age was fixed at 36, to the unimpaired judgment of the House of Commons. It was found that the enormous services rendered by women to the nation during the war had broken down much of the opposition to their enfranchisement. Not only had they cooperated heartily in the time-honoured female occupations of nursing, housework, and knitting for the sailors and soldiers, but they had supplied the place of men in countless occupations at home, and even in France—on the land as labourers, in the factories as munition workers, in the workshops and the engineering works, as well as in canoes, as car and van drivers, as police, as omnibus conductors, as clerks and typists throughout an overgrown Civil Service, and in three semi-military uniformed organizations, Queen Mary's Women's Army Auxiliary Corps (W.A.A.C.), the Women's Royal Naval Service (W.R.N.S.), and the Women's Royal

Air Force (Penguins). One after another, the most prominent opponents of woman's suffrage, such as Mr. Asquith and Mr. Walter Long, announced their conversion; and the House of Commons accepted the proposal to give women the vote by an enormous majority—the clause being added to by 214 to 17. The gift of the franchise to women was gracefully completed in the autumn of 1918 by the passing, with little opposition, of a bill enabling them to sit in Parliament. Proportional representation, after many vicissitudes, and a disagreement between the Lords who supported and the Commons who rejected the system, was finally excluded from the measure, save in regard to university elections. Further interesting provisions in the bill disqualified conscientious objectors, unless they had done national service, until five years after the war, and gave the vote to sailors and soldiers at 19 (other men not being qualified till 21), on the ground that if they were qualified to fight for the country they were qualified to vote. Arrangements were also made for taking their votes in their absence on service. There were some warm debates as to whether there should be redistribution of seats in Ireland as well as in Great Britain; but finally Ireland was included, the quota for a member there being fixed at 43,000, as compared with 70,000 in Great Britain. Thirty-seven members were added to the House of Commons, making 707 in all. It was calculated that this Reform bill, which became law in Jan. 1918, enfranchised 8,000,000 new voters, of whom 6,000,000 were women.

Mr. Fisher's educational policy was sketched by him in speaking on the education estimates in April 1917, when he said that both trade unions and enlightened employers were demanding educational reform; and he further laid a bill before the House in August of that session with no serious intention of pressing it, but so as to familiarize the educational world with his proposals. In 1918, he reintroduced it and passed it into law. One part of his policy consisted in a considerable increase in the pay of teachers, so that they might be relieved from perpetual financial anxiety. He also proposed a new system of special grants for secondary schools, which were, he said, the key of the situation. For these objects he obtained, in 1917, an increase of four millions in his estimates. The proposals in his bill of 1918 he estimated would cost more than 100 millions in addition. But, in spite of the cost, so strongly was the need felt, both in Parliament and in the country, for improved education, that a view to reconstruction and progress after the war, that the opposition was comparatively slight. As passed into law, the measure provided for the compulsory attendance at school of all children up to 14 years old, and at continuation schools in the day-time for 80 hours the year up to 18, unless they had received full-time education up to 16. Exemption after 16 was allowed for the first seven years after the coming of the Act into force. The main purpose of the continuation schools was to ensure that all the money and effort spent on the elementary schools should not be wasted. No child under 12 was allowed to be employed, at all and no child over 12 was to be allowed to be employed on school days except after school hours and before 8 p.m. Thus, in spite of the protests of Lancashire, the "half-timer" was abolished. No fees were to be charged in either public elementary schools or in continuation schools, on the principle that, when education is compulsory, it ought to be free. Provision was made for nursery schools, holiday and school camps, playing-fields, physical training, and the medical inspection of places of higher education. Local education authorities were made responsible in their areas, and the limit on the spending powers of authorities for higher education was abolished.

In spite of the failure of Mr. Lloyd George's first negotiations in the summer of 1916, he was still anxious to find an agreed settlement. The Nationalists threatened in March 1917 to adopt "the hard obstructive opposition" to Government, unless Home Rule were at once put in force. In May, the Prime Minister, in a letter to Mr. Redmond and Sir Edward Carson, offered to introduce a bill applying the Home Rule Act at once to southern

Reform Bill.

Education of Reform.

Mr. Fisher's Bill.

Woman's Suffrage Bill.

Home Rule Bill.

Ireland, but exempting north-east Ulster for five years, and providing for delegations representing both areas, with power to unify Irish legislation. If this plan was not satisfactory, he suggested that a convention of Irishmen of all parties should be assembled in Ireland in order to produce a scheme of their own to submit to the British Parliament. Neither the Nationalists nor the southern Unionists would accept Mr. Lloyd George's specific plan; but all parties except Sinn Fein accepted the idea of an Irish convention. Representative men, many of them non-political, were chosen to take part in the assembly; and, in order to produce an atmosphere of harmony, the Government released without reservations all the political prisoners in confinement for connexion with the Dublin rebellion. One of these was Mr. De Valera, who refused to have anything to do with the convention, and who was almost immediately elected M.P. for East Clare by an enormous majority. In spite of this ominous event, which showed that popular favour in southern Ireland was deserting the Nationalists for Sinn Fein, the Convention duly met on July 25, at Regent House, Trinity College, Dublin, and unanimously appointed Sir Horace Plunkett as their chairman. The Convention sat for many months, but, though there was an unexpected amount of agreement in some respects, it failed to arrive at anything approaching a unanimous report. The spread of the Sinn Fein movement in

*Sinn Fein  
Conspirator.*

Ireland, the death from hunger strike of a Sinn Fein prisoner, and the illness and death of John Redmond, the Nationalist leader and a leading member of the conference, contributed to this untoward result. It was in April 1918 that the report was issued; and Sir Horace Plunkett claimed, in a letter to the Prime Minister, that "the Convention has laid the foundation of Irish agreement unprecedented in history." The Government, with no definite guidance from the Convention, proceeded to draft their own proposals; but these were not submitted to Parliament, as Lord French and Mr. Sherriff, newly appointed Lord Lieutenant and Chief Secretary, discovered in May a further treasonable conspiracy between the Sinn Fein leaders and Germany, by which the Germans were to supply munitions for a rebellion to follow a successful German offensive in France. The Sinn Fein headquarters were raided by the police and 150 Sinn Fein leaders were arrested under the Defence of the Realm Act. In view of the disturbed state of Ireland, ministers, though they were harassed by the Nationalists in Parliament for their inaction, determined to postpone legislation.

Lord Rhondda, at the outset of his Ministry, obtained a much larger control and wider scope than had been possessed by his predecessor as Food Controller. He took over the Oils and Fats Department from the Ministry of Munitions and was given by Order in Council the same powers as the Admiralty, Army Council, and Ministry of Munitions already possessed, for requisitioning and controlling prices. The new crop of potatoes enabled him to abolish potatoless days; but it was to prices, which had risen enormously owing not merely to speculation and profiteering, but to deficient harvests, shortage through submarine depredations, and the depreciation of currency caused by the vast issues of paper money all over the world, that he mainly directed his attention. He explained his policy, in the House of Lords on July 26 1917, as being one of determining prices at every stage from the producer to the retailer, on the principle of allowing a reasonable pre-war profit. Existing agencies were to be used for the purposes of distribution under licence and control and under the supervision of local food controllers to be appointed by the local authority. He took over all the flour mills, and at heavy cost to the Exchequer reduced the price of flour so as to enable bread to be sold at 9d. per quarter loaf instead of the existing price of 2s. He fixed a sliding scale for prices of live cattle, but left the fixing of retail prices for joints to the local food committees. The appointment of local committees and fixing of prices went on regularly during the autumn of 1917 till hardly any kind of food was left at market price; and a vigorous economy campaign was organized under the direction of Sir

*Lord Rhondda  
as Food  
Controller.*

Arthur Yapp, of the Y.M.C.A., as Director-General of Food Economy. Sugar cards were issued in October. The sale of ice cream, save for children and invalids, was prohibited during the winter months. A new scale of voluntary rations, not applying to children, was issued in November. The bread ration varied from 8 lb. per week for men on the heaviest manual labour to 3 lb. 8 oz. for women on sedentary work. For other foods the weekly ration was to be: cereals other than bread, 12 oz.; meat, 2 lb., butter, margarine, oils and fats, 10 oz.; sugar, 8 oz. In December there were sporadic shortages of food of all kinds, and food queues at butchers', grocers' and bakers' shops became longer and more frequent, creating great dissatisfaction among all classes, especially the working-classes. To meet the difficulty in part Lord Rhondda gave powers to local committees to transfer stocks of margarine from retailers who were well supplied to those who were deficient; he also set up a Consumers' Council to advise the Ministry of Food; and he gave permission to the Birmingham Food Control Committee to try an experiment with a scheme whereby each household should be supplied with a card entitling them to prescribed rations of tea, butter and margarine to be procured from a particular registered retailer. As the year drew to a close, it was obvious, and Lord Rhondda admitted it himself, that compulsory rationing would have to come.

It should be noted that Government control was extended during 1917 over other staple industries besides those dealing with food. In July the cotton trade was brought under a board of control consisting of spinners, manufacturers, importers, distributors and workmen, together with representatives of the Board of Trade. In September a similar board was set up by the Army Council to regulate the woollen and worsted trade. Railways, the liquor trade, shipping, and mines had already passed successively under ministerial direction; as the strain of war grew more severe, the tendency inevitably was for each trade to set up a representative body to direct its functions and activities, through consultation with the Government. It may be added that, though it was no part of ministerial intention to discourage amusement and recreation, it was found necessary to suspend racing in May 1917.

Mr. Lloyd George followed Mr. Asquith closely in his statements during the year of the war aims pursued by the Allies, and in his repudiation of an inconclusive peace. At Glasgow in July he said that "we should continue to fight for the great goal of international right and international justice, so that never again can brute force sit on the throne of justice, nor barbaric strength wield the sceptre of right." Mr. Asquith at Liverpool in October said that the worst that could happen to the world would be a patched-up peace; Gen. Smuts, who made several speeches while he remained in England as a member of the War Cabinet, said at Cardiff in the same month that the present struggle was deciding upon what basis the future would be built, whether on freedom, or on the will to power and the will to force. An entirely different note was struck by Lord Lansdowne, advocating in November, in a letter to the *Daily Telegraph* (which *The Times* had previously declined to publish), a negotiated peace. He received no support, save from professed pacifists; and Mr. Lloyd George took occasion to warn people against the man who thought there was a half-way house between defeat and victory. He admitted that it was a bad moment for the Allies in the war, because Russia had stopped and America was only preparing to come in. Certainly the course of the war in the autumn was unsatisfactory. Italy had been invaded in October and her armies driven back to the Piave, the fruits of Sir Julian Byng's brilliant victory, by the first use of tanks at Cambrai in November, had been largely neutralised by a German counterstroke, and in December a regular armistice was concluded between Germany and Russia, to be finally turned in the beginning of March 1918 into the humiliating treaty of Brest-Litovsk. Russia went out of the war; but Great Britain had a gleam of success in the end of the year through the capture of Jerusalem by Sir Edmund Allenby.

*New Scale  
of Rations  
for  
Children.*

*General  
Control of  
Trade.*

*Leading  
Men and  
War Aims.*

*A Bad  
Moment for  
the War.*

The prospect was sufficiently anxious fully to warrant the renewed call of the Prime Minister in the new year for sacrifice—sacrifice worthy of the sacrifices made by those at the front. "To every civilian," he wrote in a message to the nation, "I would say: 'Your firing-line is the works or the office in which you do your bit; the shop or the kitchen in which you spend or save; the bank or the post-office in which you buy your bonds.'" Sir Auckland Geddes immediately illustrated the necessity of sacrifice by introducing a bill, the chief effect of which was to call up from civil employment a number of young men who had hitherto been exempt from military service; and he announced that it was necessary to raise immediately 420,000 to 450,000 from this class. After some demur the trade unions agreed to co-operate in making the measure effective, and it became law on Feb. 6.

The finance of the war called this year for greater sacrifices from the taxpayer than ever before. The money voted for military purposes exceeded that of any previous year. Mr. Law obtained votes of credit for £600,000,000 in March; £500,000,000 in June; £700,000,000 (the largest amount ever voted in one sum) in August; and again for £700,000,000 in November. This made a total of £3,742,000,000 for the whole war (of which £1,465,000,000 had been lent to the Allies down to the Armistice). The average daily expenditure, which was £6,986,000 in 1917-8, fell in the seven war months of 1928-9 to £6,688,000. In his budget, introduced in April, Mr. Law made unprecedented demands on the taxpayer, in order to raise sufficient revenue to cover the peace expenditure and the increased debt charge. He imposed additional taxation estimated to bring in £114,000,000. Income tax was raised from 5s. to 6s. in the £, the farmers' tax was doubled; rates of supertax increased up to a maximum of 4s. 6d. in the £, and the limit of exemption lowered from £3,000 to £2,500; a 2d. stamp tax was placed on cheques; beer and spirit duties were doubled, and sugar, tobacco, and match duties raised; letter rate was raised to 1½d. and post card rate to 1d.; and there was to be a luxury tax of 2d. in the shilling. This last tax was eventually dropped, after a select committee of the House of Commons had spent many weeks in examining and reporting on its possibilities. There was little opposition to the rest of the proposals, save to the doubling of the stamp on cheques, against which there was considerable protest in the City, which the Chancellor of the Exchequer disregarded. Protests, however, were raised against extravagance and waste, without

*Mr. Law's Second Budget.*

*High Expenditure.*

which the estimates of expenditure and revenue would hardly have reached the gigantic totals of £2,972,197,000 and £842,050,000, leaving a deficit of £2,130,147,000 to be met by loan. It was estimated in January by Mr. Herbert Samuel, chairman of a select committee of the House of Commons on national expenditure, that the following increases had taken place since the preceding August: the 9d. loaf, £45,000,000; bonus to potato-growers, £5,000,000; to miners, £20,000,000; to munition workers, £40,000,000; to railwaymen, £10,000,000; and to civil servants, £3,000,000; increases in pay to officers, over £7,000,000; to soldiers, £65,000,000. The increases of pay voted to navy and army by Parliament in 1917 were, it may be explained, overdue, and were only a fitting acknowledgment of their heroic service. It should be added that in the autumn of 1918 the Government made provision for the intellectual welfare of soldiers by establishing a new department, under the charge of Col. Lord Gorell, to direct and coordinate education in the army.

It was in the matter of food that the sacrifices demanded were most felt by the bulk of the population. In January the quantity of staple foods which might be consumed by visitors in hotels and by people taking casual meals was limited by order, and in February compulsory rationing of meat was enforced in London and the Home Counties. Meat cards were issued, with coupons attached, under conditions that restricted the weekly adult ration to 1s. 3d. worth of butcher's meat, together with other meat equivalent to 5 oz. of butcher's meat. At the same time butter

*Compulsory Rationing of Meat.*

and margarine were rationed, 4 oz. being allowed per head per week. At first there was a good deal of outcry against Lord Rbonda, as there had been against Lord Devonport, and attacks were made upon him in both Houses of Parliament, on account of his interferences with the course of trade, his "meddling and meddling." But in the Lords he was defended with spirit by Lord Milner, who said "that we were in a better position as regards food than any of the other countries engaged in the war; that, however the German submarine campaign might have embarrassed us, it had certainly not starved us and had not diminished the necessary supplies of our armies in the field." Mr. Clynes, the parliamentary Under-Secretary of the Department, claimed with justice that, under its arrangements, the poorest people were going to have an equal chance with their richer brethren, and that men, women and children, and not money, would be the consideration that would determine the appropriation of food. The Government, he said, had taken the place of the merchant and importer. The shortage of coal demanded further sacrifices by the general consumer. It was found necessary to supplement the "summer time" arrangement, now become permanent, by a curfew order, limiting the hours for lights and fires, and compelling theatres to close at 10:30; and gas and electric light were rationed. Later on in the year railway facilities were greatly diminished, and fares increased.

The Government was criticised at the opening of the parliamentary session of 1918 for failing to reach the high standard they had set themselves in the departments of man-power, food production and shipbuilding. But Mr. Law pointed out that in 1917 they had put into the army 820,600 additional men; had brought a million more acres under the plough, producing an additional 850,000 tons of cereals and 3,000,000 tons of potatoes; and had built 1,163,474 tons of shipping, compared with a tonnage of 530,000 built in 1916. Another subject of criticism was the arrangement made with the Allies for the joint conduct of the war. Here the Government had been very active. The unity and continuity of direction which Mr. Lloyd George had ensured in the prosecution of the war, so far as the British forces were concerned, by the institution of his small War Cabinet in permanent session, he and his Cabinet earnestly desired to see more completely realized in the joint councils of the Allies. At a meeting of leading ministers of the principal Allies, held at Rapallo in the autumn of 1917, a plan of coordination was approved. A war council, composed of the Prime Minister and another member of each of the three Governments of France, Italy and Great Britain, was constituted

*Co-ordination of Allied Action.*

*The Versailles Council.*

to meet at Versailles normally not less than once a month, and it was hoped that other Great Powers, especially the United States, would join the council. Mr. Lloyd George was in Paris in November 1917 for the first meeting; but he was disappointed with the results, and, at a luncheon there, he made an appeal to public opinion in the various Allied countries, by delivering a very pessimistic and, as it seemed to many, a very injudicious speech, in which he declared that unless some change were effected he could no longer remain responsible for a war direction doomed to disaster from lack of unity. He succeeded in drawing public attention; but the critics were disposed to suggest that this was a new device to enable politicians to interfere with work properly belonging to soldiers. One of Mr. Lloyd George's difficulties in securing coordination had been the instability of French ministers during 1917. M. Briand's Ministry, after a tenure of office of 18 months, fell in March; M. Ribot, who succeeded him, was overturned in September; M. Painlevé, the next prime minister, only lasted two months; but, fortunately, in his successor, M. Clemenceau, France obtained a chief whose whole thoughts, like Mr. Lloyd George's, were devoted to winning the war. With his cooperation the Versailles Council was strengthened, and arrangements were made to coordinate it with the general staffs of the various Allies by each appointing a staff officer as permanent military adviser at Versailles. This arrangement cost the Government the services of Sir William Robertson, the chief of the staff, who refused either to take the military advisership,

which fell to Sir Henry Wilson, or to continue in office unless the military adviser at Versailles were merely his deputy.

In fact, Mr. Lloyd George and his Cabinet had by no means reached their aim of satisfactory coordination when the great German advance began on March 21. The British and French armies were both driven back in a series of bloody battles, and they were seriously menaced with a rupture of their contact with each other by a fierce attack which the Germans directed against Amiens. Then it was realized that what the Allied forces in France needed for success was not an Allied council but a single military head. Sir Douglas Haig agreed in this with Lord Milner, who was then representing the War Cabinet in France, and with M. Clemenceau; and Gen. Foch, the most scientific of French soldiers, who had already distinguished himself highly in the war, was appointed Generalissimo, to the general satisfaction.

The next few months in Britain were perhaps the most anxious time of the whole war. A fresh Military Service bill was at once introduced, raising the military age to 50 and in certain cases to 55, and Ireland was for the first time to be included in a compulsory measure, ministers announcing at the same time that they were about to introduce a fresh Home Rule bill based on a consideration of the reports of the Irish Convention. The bill was hotly opposed, not only by the Nationalists, but by many experienced members who doubted whether it would really give ministers the men they needed. But Mr. Law insisted on carrying it as it stood, and told the Nationalists that they did not realize the growing bitterness in England at the exemption hitherto of Ireland from the sacrifices demanded of Great Britain. The bill was carried by majorities of 200; but it was never in fact put in force in Ireland. The Roman Church joined the Nationalists and Sinn Feiners in denouncing conscription, and the Government, having to abandon this project, abandoned also the attempt to pass this year a Home Rule bill.

Besides this new Military Service Act, the Government strengthened the forces in France by sending at once to Sir Douglas Haig a large proportion of the men hitherto retained in the island as a home defence army, and they instituted a vigorous comb-out once more of munition workers, miners, and the Civil Service. They strengthened the War Office, by making Lord Milner, the most vigorous member of the War Cabinet after the Prime Minister, Secretary of State for War; Lord Derby going as British ambassador to Paris, where he admirably reinforced the good understanding of the two Powers. The vacancy in the War Cabinet was filled by Mr. Austen Chamberlain. About the same time Sir William (since Lord) Welb succeeded Lord Rothermere as Air Minister.

The strain engendered by the serious situation of the British forces in France produced some regrettable recriminations in Parliament *à propos* of the substitution of Gen. Sykes for Gen. Trenchard as chief of the air staff, and of a letter which a distinguished general, Sir Frederick Maurice, late director of military operations, thought fit to write to *The Times*, accusing ministers of making statements to Parliament, giving "a totally misleading impression" of the military situation. Ministers in this latter case offered to refer the charges to two judges, but the leading Liberals refused this tribunal, and Mr. Asquith, for the first time definitely acting as leader of opposition, moved to refer the allegations to a select committee of the House of Commons. Mr. Lloyd George, in debate, categorically and in detail maintained the truth of the Ministerial statements, and the motion was rejected by 293 votes to 106 votes. Gen. Maurice, for his breach of discipline, was placed by the Army Council on retired pay; and became a military correspondent for the press. The anxieties of the times also revived the strong feeling about the alien danger; and, in deference to public opinion, certificates of internment and naturalization were revised, no aliens were allowed to be employed in Government offices during the war; new measures were taken to establish the identity of aliens, and drastic restrictions were imposed on changes of name. Enemy

banks, too, were finally wound up, and it was provided that no such banks should be established for a period after the war.

The food condition was better this summer, owing to Lord Rhondda's admirable arrangements for securing supplies from all quarters of the world, and to the diminution of the menace from submarines owing to the provision of submarine chasers and other methods. Compulsory rations of meat, however, continued, though a larger quantity was allowed. Tea, too, was rationed, and though milk was not rationed its price was fixed according to the season. Arrangements were made to get in the harvest, in the absence of men at the front, by a great volunteer contingent of public-school boys in their holidays, and of women. The Food Controller established with great success national kitchens, and afterwards, in a few great towns, national restaurants. On July 3 Lord Rhondda died, just when he had arranged to introduce, in place of the loose cards hitherto used, a system of ration books. These were brought into use by his successor, Mr. Clynes, on July 14, and contained coupons for sugar, butter or margarine, lard, butcher's meat and bacon. Thus a satisfactory national system was at last evolved, which worked well and favoured no one.

While it was generally admitted that the War Cabinet was a much better organ for the conduct of the war than any of the previous arrangements, there was frequent complaint that the result of concentrating all real directing power in the hands of four to six men, all deeply engaged in the war, was that domestic affairs were insufficiently attended to. Accordingly in June 1918 a Committee on Home Affairs was appointed, which was to meet, at least once a week, under the chairmanship of the Home Secretary. All domestic questions requiring the cooperation of two or more Departments and calling for Cabinet decision were to be referred to it. The Committee were to have the power of decision, on behalf of the Cabinet, but larger questions of policy were to be referred to the War Cabinet.

The fourth anniversary of the war, being a Sunday, was observed as a day of national intercession, to invoke the Divine Blessing on the country's cause. Marshal Foch's offensive had been in progress for more than a fortnight; but it was still far from clear whether it could proceed without a check. Mr. Lloyd George sent a stirring message on the day to the Empire, bidding Britons to "hold fast." The battle, he told them, was not yet won. "We cannot seek to escape the horrors of war for ourselves by laying them up for our children. Having set our hands to the task we must see it through till a just and lasting settlement is achieved." The appeal was timely, but many of the workers paid little heed to it.

Throughout August and September, while the Allied troops in France, and especially the British armies, were winning victory after victory and steadily driving the Germans out, and while Bulgaria and Turkey were being forced to surrender, a series of strikes broke out all over the country, in many cases promoted not by the unions but by the shop stewards. Women workers in London on omnibuses and tubes struck to obtain the same war bonus as that accorded to the men. The strike spread to Bath, Bristol, Brighton, Polkestone, Hastings, and Weston-super-Mare, but the women returned to work in a couple of days on a promise of full consideration of their demand, which was eventually conceded. A much more serious matter was the London police strike which, without notice, deprived London for two days, Friday and Saturday, Aug. 30 and 31, of police protection. Undoubtedly the Metropolitan Police had grievances in regard to wages and allowances, which had been under consideration of the authorities for an unconscionable time without result, but it was a shock to public confidence that the defenders of law and order should have thought themselves at liberty to leave the public defenceless in order to call attention to their claims. Sir Edward Henry, the Commissioner of Police, resigned, and was succeeded by Gen. Macready; but it was believed that it was the Home Office that was mainly to blame. Mr. Lloyd George settled the strike by granting the men liberal terms; but he

Appoint-  
ment of a  
General-  
issimo.

New  
Military  
Service  
Bill

Other  
Military  
Measures.

General  
Maurice's  
Charge.

Ration  
Books.

Committee  
on Home  
Affairs.

Strikes in  
1918.

declined to recognize any union of the police. There was a strike of Lancashire operative cotton-spinners in September against the advice of their union, but the men returned to work on an appeal by Mr. Lloyd George, who promised to appoint at once a tribunal of inquiry. The tribunal allowed an increase of wages, but rejected the men's claim to decide the nature of their unemployment benefit. The most serious strike was that of railway men, especially in the South Wales district, in the same month. There was a dispute as to the extent of the advance to be granted in wages, and the National Union of Railwaymen and the War Cabinet agreed upon a certain scale. But the men threw over their leaders, and were only brought to reason when the Courts prohibited the unions from paying strike pay to their members. Mr. J. H. Thomas resigned the secretaryship of the National Union, and was only induced to return after a while on a promise of better observance of discipline. These and other less important strikes caused the Trade Union Congress at Derby to impress upon trade unions the desirability of a frank acceptance of the Whitley Report and joint industrial councils.

Other causes of anxiety of the autumn were a severe attack of influenza, which spread rapidly from July onwards, caused the weekly death roll by the end of October to rise in London to 761, and in 96 great towns to 1,895, and only began to wane in November; a great deficiency in coal which led to household rationing, and to great economies in lighting and heating arrangements by municipalities and other public bodies; a reduction in the meat ration, and the sufferings of the British prisoners in Germany, and her delay in ratifying the League agreement for reciprocal return of prisoners which had been negotiated by Sir George Cave and Lord Newton.

But from the end of September onwards the persistent and accumulating good news from every seat of war gradually changed the attitude of the country from one of anxiety to one of increasingly hopeful expectation. An opening a war bond campaign at the Guildhall on Sept. 30; Mr. Bonar Law concluded his speech with a new accent: "I do not say that this is the end, but I do say that this is the beginning of the end." For the purpose of the appeal Trafalgar Square was turned into a realistic representation of a shell-shattered French village. The "Feed the Guns" week, which was started by the opening of this show on Oct. 7, was all the more successful, as President Wilson was already in correspondence with the Central Powers as to the general principles on which peace could be based. By the time that Nov. 9, Lord Mayor's Day, came round, terms of armistice, amounting in effect to surrender, had been handed by Marshal Foch and Admiral Wemyss to a German delegation, and the news of their acceptance was hourly expected. The Lord Mayor's Show, with tanks and captured guns, and detachments of British, Imperial and Allied troops and of Women's Auxiliary Corps, typified the magnificent effort of the Empire now being crowned with victory; but on that Saturday evening the Prime Minister could only say at the Guildhall banquet, "I have no news for you."

It was on Monday morning, Nov. 11, at 11 o'clock, that the bursting of balloons announced to London that the Armistice had been signed, that hostilities had ceased, and that the war, in all human probability, was over. Almost instantly crowds poured into the streets; flags and decorative rugs and tapestries were hung out of windows throughout the centre of the town, from public offices and private houses, and a great throng assembled at Buckingham Palace to cheer the King, who appeared with the Queen on the balcony, and showed how fully he shared the rejoicings of his subjects. The scenes of enthusiasm and public jubilation in the streets throughout the day were indescribable. When the House of Commons met, the Prime Minister read out the terms of the Armistice, and added, "This is no time for words. Our hearts are too full of gratitude, to which no tongue can give adequate expression." Immediately the two Houses of Parliament, led by the Lord Chancellor and the Speaker, proceeded to St. Margaret's church to give thanks to God. Next day the King and Queen attended a special service of thanksgiving at St. Paul's. The general rejoicings lasted

throughout the week. Before Parliament was prorogued, both Houses voiced addresses of congratulation to the King, which were presented to him in the Royal Gallery of the Palace of Westminster; and His Majesty, recalling the splendid services of the sailors and soldiers from all parts of his Dominions, pledged himself anew to uphold the honour of the Empire and to promote the well-being of the people. Before the month was out, in accordance with the terms of the Armistice, the German 5th, 6th, 7th, 8th, 9th, 10th, 11th, 12th, 13th, 14th, 15th, 16th, 17th, 18th, 19th, 20th, 21st, 22nd, 23rd, 24th, 25th, 26th, 27th, 28th, 29th, 30th, 31st, 32nd, 33rd, 34th, 35th, 36th, 37th, 38th, 39th, 40th, 41st, 42nd, 43rd, 44th, 45th, 46th, 47th, 48th, 49th, 50th, 51st, 52nd, 53rd, 54th, 55th, 56th, 57th, 58th, 59th, 60th, 61st, 62nd, 63rd, 64th, 65th, 66th, 67th, 68th, 69th, 70th, 71st, 72nd, 73rd, 74th, 75th, 76th, 77th, 78th, 79th, 80th, 81st, 82nd, 83rd, 84th, 85th, 86th, 87th, 88th, 89th, 90th, 91st, 92nd, 93rd, 94th, 95th, 96th, 97th, 98th, 99th, 100th, 101st, 102nd, 103rd, 104th, 105th, 106th, 107th, 108th, 109th, 110th, 111th, 112th, 113th, 114th, 115th, 116th, 117th, 118th, 119th, 120th, 121st, 122nd, 123rd, 124th, 125th, 126th, 127th, 128th, 129th, 130th, 131st, 132nd, 133rd, 134th, 135th, 136th, 137th, 138th, 139th, 140th, 141st, 142nd, 143rd, 144th, 145th, 146th, 147th, 148th, 149th, 150th, 151st, 152nd, 153rd, 154th, 155th, 156th, 157th, 158th, 159th, 160th, 161st, 162nd, 163rd, 164th, 165th, 166th, 167th, 168th, 169th, 170th, 171st, 172nd, 173rd, 174th, 175th, 176th, 177th, 178th, 179th, 180th, 181st, 182nd, 183rd, 184th, 185th, 186th, 187th, 188th, 189th, 190th, 191st, 192nd, 193rd, 194th, 195th, 196th, 197th, 198th, 199th, 200th, 201st, 202nd, 203rd, 204th, 205th, 206th, 207th, 208th, 209th, 210th, 211st, 212th, 213th, 214th, 215th, 216th, 217th, 218th, 219th, 220th, 221st, 222nd, 223rd, 224th, 225th, 226th, 227th, 228th, 229th, 230th, 231st, 232nd, 233rd, 234th, 235th, 236th, 237th, 238th, 239th, 240th, 241st, 242nd, 243rd, 244th, 245th, 246th, 247th, 248th, 249th, 250th, 251st, 252nd, 253rd, 254th, 255th, 256th, 257th, 258th, 259th, 260th, 261st, 262nd, 263rd, 264th, 265th, 266th, 267th, 268th, 269th, 270th, 271st, 272nd, 273rd, 274th, 275th, 276th, 277th, 278th, 279th, 280th, 281st, 282nd, 283rd, 284th, 285th, 286th, 287th, 288th, 289th, 290th, 291st, 292nd, 293rd, 294th, 295th, 296th, 297th, 298th, 299th, 300th, 301st, 302nd, 303rd, 304th, 305th, 306th, 307th, 308th, 309th, 310th, 311st, 312th, 313th, 314th, 315th, 316th, 317th, 318th, 319th, 320th, 321st, 322nd, 323rd, 324th, 325th, 326th, 327th, 328th, 329th, 330th, 331st, 332nd, 333rd, 334th, 335th, 336th, 337th, 338th, 339th, 340th, 341st, 342nd, 343rd, 344th, 345th, 346th, 347th, 348th, 349th, 350th, 351st, 352nd, 353rd, 354th, 355th, 356th, 357th, 358th, 359th, 360th, 361st, 362nd, 363rd, 364th, 365th, 366th, 367th, 368th, 369th, 370th, 371st, 372nd, 373rd, 374th, 375th, 376th, 377th, 378th, 379th, 380th, 381st, 382nd, 383rd, 384th, 385th, 386th, 387th, 388th, 389th, 390th, 391st, 392nd, 393rd, 394th, 395th, 396th, 397th, 398th, 399th, 400th, 401st, 402nd, 403rd, 404th, 405th, 406th, 407th, 408th, 409th, 410th, 411st, 412th, 413th, 414th, 415th, 416th, 417th, 418th, 419th, 420th, 421st, 422nd, 423rd, 424th, 425th, 426th, 427th, 428th, 429th, 430th, 431st, 432nd, 433rd, 434th, 435th, 436th, 437th, 438th, 439th, 440th, 441st, 442nd, 443rd, 444th, 445th, 446th, 447th, 448th, 449th, 450th, 451st, 452nd, 453rd, 454th, 455th, 456th, 457th, 458th, 459th, 460th, 461st, 462nd, 463rd, 464th, 465th, 466th, 467th, 468th, 469th, 470th, 471st, 472nd, 473rd, 474th, 475th, 476th, 477th, 478th, 479th, 480th, 481st, 482nd, 483rd, 484th, 485th, 486th, 487th, 488th, 489th, 490th, 491st, 492nd, 493rd, 494th, 495th, 496th, 497th, 498th, 499th, 500th, 501st, 502nd, 503rd, 504th, 505th, 506th, 507th, 508th, 509th, 510th, 511st, 512th, 513th, 514th, 515th, 516th, 517th, 518th, 519th, 520th, 521st, 522nd, 523rd, 524th, 525th, 526th, 527th, 528th, 529th, 530th, 531st, 532nd, 533rd, 534th, 535th, 536th, 537th, 538th, 539th, 540th, 541st, 542nd, 543rd, 544th, 545th, 546th, 547th, 548th, 549th, 550th, 551st, 552nd, 553rd, 554th, 555th, 556th, 557th, 558th, 559th, 560th, 561st, 562nd, 563rd, 564th, 565th, 566th, 567th, 568th, 569th, 570th, 571st, 572nd, 573rd, 574th, 575th, 576th, 577th, 578th, 579th, 580th, 581st, 582nd, 583rd, 584th, 585th, 586th, 587th, 588th, 589th, 590th, 591st, 592nd, 593rd, 594th, 595th, 596th, 597th, 598th, 599th, 600th, 601st, 602nd, 603rd, 604th, 605th, 606th, 607th, 608th, 609th, 610th, 611st, 612th, 613th, 614th, 615th, 616th, 617th, 618th, 619th, 620th, 621st, 622nd, 623rd, 624th, 625th, 626th, 627th, 628th, 629th, 630th, 631st, 632nd, 633rd, 634th, 635th, 636th, 637th, 638th, 639th, 640th, 641st, 642nd, 643rd, 644th, 645th, 646th, 647th, 648th, 649th, 650th, 651st, 652nd, 653rd, 654th, 655th, 656th, 657th, 658th, 659th, 660th, 661st, 662nd, 663rd, 664th, 665th, 666th, 667th, 668th, 669th, 670th, 671st, 672nd, 673rd, 674th, 675th, 676th, 677th, 678th, 679th, 680th, 681st, 682nd, 683rd, 684th, 685th, 686th, 687th, 688th, 689th, 690th, 691st, 692nd, 693rd, 694th, 695th, 696th, 697th, 698th, 699th, 700th, 701st, 702nd, 703rd, 704th, 705th, 706th, 707th, 708th, 709th, 710th, 711st, 712th, 713th, 714th, 715th, 716th, 717th, 718th, 719th, 720th, 721st, 722nd, 723rd, 724th, 725th, 726th, 727th, 728th, 729th, 730th, 731st, 732nd, 733rd, 734th, 735th, 736th, 737th, 738th, 739th, 740th, 741st, 742nd, 743rd, 744th, 745th, 746th, 747th, 748th, 749th, 750th, 751st, 752nd, 753rd, 754th, 755th, 756th, 757th, 758th, 759th, 760th, 761st, 762nd, 763rd, 764th, 765th, 766th, 767th, 768th, 769th, 770th, 771st, 772nd, 773rd, 774th, 775th, 776th, 777th, 778th, 779th, 780th, 781st, 782nd, 783rd, 784th, 785th, 786th, 787th, 788th, 789th, 790th, 791st, 792nd, 793rd, 794th, 795th, 796th, 797th, 798th, 799th, 800th, 801st, 802nd, 803rd, 804th, 805th, 806th, 807th, 808th, 809th, 810th, 811st, 812th, 813th, 814th, 815th, 816th, 817th, 818th, 819th, 820th, 821st, 822nd, 823rd, 824th, 825th, 826th, 827th, 828th, 829th, 830th, 831st, 832nd, 833rd, 834th, 835th, 836th, 837th, 838th, 839th, 840th, 841st, 842nd, 843rd, 844th, 845th, 846th, 847th, 848th, 849th, 850th, 851st, 852nd, 853rd, 854th, 855th, 856th, 857th, 858th, 859th, 860th, 861st, 862nd, 863rd, 864th, 865th, 866th, 867th, 868th, 869th, 870th, 871st, 872nd, 873rd, 874th, 875th, 876th, 877th, 878th, 879th, 880th, 881st, 882nd, 883rd, 884th, 885th, 886th, 887th, 888th, 889th, 890th, 891st, 892nd, 893rd, 894th, 895th, 896th, 897th, 898th, 899th, 900th, 901st, 902nd, 903rd, 904th, 905th, 906th, 907th, 908th, 909th, 910th, 911st, 912th, 913th, 914th, 915th, 916th, 917th, 918th, 919th, 920th, 921st, 922nd, 923rd, 924th, 925th, 926th, 927th, 928th, 929th, 930th, 931st, 932nd, 933rd, 934th, 935th, 936th, 937th, 938th, 939th, 940th, 941st, 942nd, 943rd, 944th, 945th, 946th, 947th, 948th, 949th, 950th, 951st, 952nd, 953rd, 954th, 955th, 956th, 957th, 958th, 959th, 960th, 961st, 962nd, 963rd, 964th, 965th, 966th, 967th, 968th, 969th, 970th, 971st, 972nd, 973rd, 974th, 975th, 976th, 977th, 978th, 979th, 980th, 981st, 982nd, 983rd, 984th, 985th, 986th, 987th, 988th, 989th, 990th, 991st, 992nd, 993rd, 994th, 995th, 996th, 997th, 998th, 999th, 1000th.

IV. AFTER THE WAR, 1918-21

The conclusion of hostilities was immediately followed by the prorogation and dissolution of Parliament and a general election. Though protests were raised in some quarters, especially by the Independent Liberals, this was quite the natural procedure. Under the Parliament Act, the now expiring Parliament should have been dissolved three years previously, in Dec. 1915, and its life had only been prolonged from time to time by special Acts in order to avoid an election during the war. A Reform bill which enormously enlarged the electorate, adding two million male and six million female voters, had been passed in Feb., and it was right, and in accordance with precedent, that the new constituency should be consulted at the earliest moment compatible with national safety. It was evident that the Government to whom the new Parliament should give its confidence would go to the Peace Conference with its hands strengthened.

Was the Coalition to continue? The two heads of the Government, the Prime Minister, Mr. Lloyd George, and Mr. Bonar Law, the leader of the Unionists, decided, to the public satisfaction, that it should, on the ground that it would be disastrous to deal on party lines with the peace negotiations and the problems of reconstruction. They issued a joint appeal for support to the Coalition Government "in the execution of a policy devised in the interest of no particular class or section, but so far as our light serves us, for the furtherance of the general good." They asked the nation to preserve the same unity in peace that it had manifested in war. They promised, among other things, to promote disarmament and a league of nations; to take special care of the soldiers and sailors who had served in the war; to increase production, especially in agriculture; to forward housing, afforestation, and transport; to give a preference to the colonies, and to preserve key industries at home; to reform the House of Lords; to develop responsible government in India; and to explore all paths towards a settlement in Ireland, with the proviso that there must be no separation and no coercion of Ulster. One element of the Coalition, the Labour party, had determined to secede; and accordingly Mr. Clynes, Mr. Hodge and Mr. Brace resigned, though Mr. Barnes preferred to leave his party and remain in the Government, and Mr. George Roberts accepted Mr. Clynes's post of Food Controller. The Labour party made great preparations to capture a large number of constituencies, but they committed the mistake of adopting among their candidates those Labour leaders who had opposed the national policy and had been notorious pacifists, as well as those who represented the patriotic majority. This attitude helped to increase the electoral support of the National Democratic party, who favoured the claims of Labour but approved of the Coalition. The Liberal party were divided. Those who had hitherto regularly supported Mr. Lloyd George were prepared to continue their support; but Mr. Asquith and those of his colleagues who had resigned with him, and a large section of the party, declined to commit themselves to any further support, and stood as Independent Liberals. In these circumstances, the Government asked for a pledge of support from candidates, and refused to assist those who declined to give it. The certificate that the pledge had been given was commonly called a "coupon," and was the subject of indignant protest by

Other Anxieties.

The Beginning of the End.

General Election of Dec. 1918.

Coalition Government.

The Armistice.



Independent Liberals and some others. In response to a popular agitation for the trial of the Kaiser, for punishment of war criminals and for full reparation from Germany, Mr. Lloyd George on the eve of the election announced that these points were included in the Coalition programme, and further that he was against conscript armies in all lands.

The election was held on Dec. 14 1918, but owing to the arrangements which had been made for taking the votes of sailors and soldiers, the votes were not counted and announced till the end of the year. The result was an overwhelming victory for the Coalition, 478 of whose official candidates were returned, constituting a majority of 249 over all non-Coalition parties. The Labour party obtained 63 seats, a number which was sufficient to constitute them the official Opposition, as the Independent Liberal party came back only 28 strong, Mr. Asquith and all his former colleagues of Cabinet rank being defeated. The same fate befell the whole of the pacifists, whether among the Labour or among the Liberal party. The defeat of Labour and Independent Liberalism would not have been so overwhelming had there not been an extraordinary number of three-cornered contests. But the resolve of the electorate that the Government which waged the war to a successful issue should make the peace and begin the reconstruction of the country was clearly manifest. In Ireland the returns indicated the collapse of the Nationalists and the triumph of Sinn Féin in the south and west. Only seven Nationalists survived, compared with 73 Sinn Féiners and 25 Unionists. The only woman returned was Countess Markievicz, a Sinn Féiner. None of the Sinn Féiners took their seats at Westminster.

Mr. Lloyd George immediately undertook a reconstruction of his Ministry. The changes were not so numerous as had been expected. Mr. Austen Chamberlain relieved Mr. Bonar Law of the extra burden of the Chancellorship of the Exchequer; Sir Frederick Smith, the Attorney-General, became Lord Chancellor, with the title of Lord Birkenhead; Lord Milner became Colonial Secretary; Mr. Walter Long was appointed First Lord of the Admiralty; Mr. Churchill was entrusted with two secretariats of State, that of War and that of Air—a combination much and reasonably criticised; Sir Robert Horne became Minister of Labour, in succession to Mr. Hodge; Mr. Andrew Weir, created Lord Inverforth, was made Minister of Munitions (rechristened "Supply"); a new Ministry, that of Ways and Communications (afterwards better named "Transport"), was created for Sir Eric Geddes; and an Indian, Sir S. P. Sinha, who had been the first native to sit on the Viceroy's Council, was made Under-Secretary for India, and created a peer. In view of the approaching Peace Conference, the system by which the Prime Minister was relieved of the labours of leadership in the Commons, by entrusting them to Mr. Bonar Law, was continued.

The last days of 1918 witnessed the reception in London of the first detachments of the returning British troops, of their victorious commander, Field-Marshal Haig, of Marshal Foch and M. Clemenceau, and especially, of President Wilson, passing through England on his way to the Paris Conference. This great assembly was opened formally by President Poincaré on Jan. 18 1919, and thenceforward for several months Mr. Lloyd George and many of his principal colleagues were absent for long periods in Paris. These tokens of victory and peace were at variance with the symptoms of domestic life in Great Britain. Within a few days of the Armistice deputations from workers, especially munition workers, were demanding of the Prime Minister a living wage. The railway men decided to withdraw the truce in their industry and demanded an 8-hour day, which the Government promptly conceded. Other industrial troubles followed. Demobilized soldiers, miners, police, boiler-makers, dock workers, engineers, all made urgent demands, with strikes declared or threatened. At first the trouble was worst on the Clyde, but the outlook was soon gloomier in London. The "tube" men came out on Feb. 3, and remained out for a week till they obtained an 8-hour day. Then the London electricians threatened to cut off all the elec-

tricity, stopping tramways and lighting, if the Government did not settle with the Clyde workers. The Government met the threat by a regulation under the Defence of the Realm Act making electrical strikers liable to six months' imprisonment.

It was in these unpropitious circumstances that Parliament met. Mr. Adamson, a miners' representative, as chairman of the Labour party, appeared as Opposition leader; and Sir Donald Maclean, who had been deputy chairman of Ways and Means in the last Parliament, led the Independent Liberals, pending Mr. Asquith's return. Ministers did not satisfy the Labour men, who moved an amendment to the Address, but were beaten by 311 to 59. The note of labour unrest thus struck resounded throughout the session and the year. Increased wages and shorter hours were demanded in trade after trade, though in most cases there had been repeated advances of wages during the war. The increase of prices, indeed, seemed to warrant, or at least excuse, a further advance. On the other hand, there was an unfortunate but natural tendency, after the strenuous labours of the past four years, to take work easily, and not merely to work shorter hours but to produce less in the hour. Further, the revolution in Russia, the deplorable effects of which on the condition of the Russian working-classes were only gradually revealed to British working men, increased the revolutionary ardour of the more advanced leaders, and disposed them to foment disputes and reject conciliation. The miners were the first in the field, demanding not merely a 30% increase in wages, and a 6-hour day, but nationalization of the mines and minerals. The Government wished, reasonably enough, before coming to a decision, to consider the effect on the general welfare of such stringent changes in the fundamental industry of the country.

The Miners' Executive however would not wait, but took a ballot which declared by a large majority in favour of a strike. A truce, however, was arranged, while the Government set up in haste a Royal Commission, presided over by Mr. Justice Sankey, the proceedings of which were hurried forward. Meantime ministers endeavoured to meet the industrial unrest by a new scheme of conciliation. Sir Robert Horne, Minister of Labour, convened on Feb. 27 a representative meeting of employers and workmen at Westminster, which Mr. Lloyd George subsequently addressed. This Joint Industrial Conference appointed a committee which recommended, *inter alia*, a maximum normal week of 48 hours, establishment by law of minimum time rates of universal application, and the creation of a permanent National Industrial Council of 400 members, elected in equal numbers by organized employers and workpeople, to advise the Government on industrial questions. The report was accepted by the conference and received sympathetically by the Government. In pursuance of this policy the Government in November introduced and passed an Industrial Courts bill, giving the Minister of Labour power to appoint courts of inquiry into trade disputes, consisting of employer, workmen and independent persons. In March the two other members, besides the miners, of the "Triple Alliance" as it was called, the railway men and the transport workers, insistently demanded improved conditions, in particular a 48-hour week. Both gained the greater part of their claims, but the railway men only after a strike resolution. The Sankey Commission produced a litter of interim reports, the chairman's, which the Government adopted, recommending an increase in wages of 2s. a day, a 7-hour day till 1921, then a 6-hour day; a penny a ton, equivalent to £1,000,000 a year, to be set aside for the improvement of housing; reorganization of the industry, and an effective voice for the miners in its direction. On nationalization no opinion was expressed in the chairman's report. The miners were still dissatisfied, but, on their leaders' advice, gave a majority on a ballot for acceptance. Subsequently, in June, the Sankey Commission issued further reports, all recommending nationalization in some form, and most of them calling attention to the alarming decrease of output. The miners' leaders insisted that the Government, having accepted the interim report, were bound also to accept the nationalization.

Labour Union

Miners' Strike and Sankey Commission

Reconstruction of the Ministry

Great Britain after the Armistice

Nationalization

advocated in the final reports. But, in Oct., Mr. Lloyd George emphatically repudiated this, and said that the nation, and not a fraction, must decide a political and economic question of this magnitude. As time went on it became increasingly evident that the nation's experience of Government control during war did not incline it to extend the system during peace. People were thoroughly sick of "bureaucracy."

The Government showed their good faith towards the Labour party by introducing and carrying through a bill restoring pre-war "trade practices," in spite of the growing evidence that many of these practices were hindrances to that increase of output which the situation needed. There was a comparative lull in trade disputes during the summer, though discontent was life among the police both in London and in Liverpool, and there was a cotton strike which was settled by an advance of 30% in wages and the concession of a 48-hour week. There were also sporadic strikes of miners in South Wales and in Yorkshire. The threatened London police strike took place on Aug. 1, the object being to compel the Government to recognize the men's union. But it was a fiasco; those who came out were less than 900 out of a total of 20,000; and they were all dismissed. The labour situation became acute in September. The Trade Union Congress which met at Glasgow on Sept. 8 was mainly concerned with "Direct Action,"—that is, the application of the industrial strike to secure political change. In spite of a spirited protest by Mr. Clynes, who adjured the Labour men to adhere to constitutional methods, the Congress passed a resolution calling for the repeal of the Conscription Acts, and the immediate withdrawal of troops from Russia, and, failing compliance by the Government, for a special Congress "to decide what action shall be taken." This was almost immediately followed by a sudden and formidable railway strike.

There had been negotiations for a standardization of wages for six months. Dissatisfied with Government concessions already amounting to £65,000,000 a year in the railway wage bill, and necessitating an advance of 50% in passenger rates and more in goods rates, a national strike was declared without warning on Sept. 26. Prompt and decisive measures to meet the threat to the nation were taken by Government. Volunteers were called for and responded in great numbers. Drastic restrictions were placed on light and fuel. Hyde Park was used as a milk depot for London. The motor lorries, which were the product of the war, proved an enormous resource. After the first few days, the railway companies began to run trains in increasing numbers. An attempt was made to involve other unions, but their officials, as a rule, promoted conciliation, and on Oct. 5 an agreement was reached, by which the Government promised stabilization of wages at their existing level till Sept. 30 1920, instead of Dec. 31 1919—a concession more of form than of substance. The strike ended on Oct. 6, having only lasted 10 days. Another dispute, not so spectacular, but gravely affecting the whole engineering trade, an iron moulders' strike, was in progress throughout all the last quarter of the year, and was finally settled at the end of the following Jan. by the concession of a 5% increase in wages instead of the 12% demanded.

Fortunately this dismal record of industrial conflict does not exhaust the story of 1919. First of all, after many vicissitudes and uncertainties, peace was made and signed at Versailles on June 28. There were royal proclamations and public rejoicings. Parliament accepted the treaty at Mr. Lloyd George's hands with only a few expressions of dissatisfaction, and on July 19 there was a great victory march through London, ending up with a deſile before the King, in front of Buckingham Palace, of the armed forces of the Empire and of those of the Allies. Sir David Beatty and Sir Douglas Haig led their men; Gen. Pershing commanded the Americans; and the Allied commander-in-chief, Marshal Foch, was himself present with his staff. The friends of the most novel portion of the Treaty of Versailles, the Covenant of the League of Nations, organized in the autumn a campaign in the country in its support,—beginning with a meeting on Oct. 23 at the Mansion House,

presided over by the Lord Mayor, and addressed by Mr. Asquith, Lord Robert Cecil, and Mr. Clynes. One result of the peace was the termination in Oct. of the exceptional methods of government improvised by Mr. Lloyd George in order to win the war, and the reversion to a Cabinet in the pre-war sense. It consisted of 20 members, being for the most part the holders of those offices which usually conferred Cabinet rank in pre-war days; but Mr. Barnes was a member, though without a portfolio; the Viceroy and Chief Secretary for Ireland were to alternate, whichever happened to be in London at the moment being summoned; and the new Minister of Transport, Sir Eric Geddes, was also included. The Cabinet Secretary and his staff were retained.

Besides the measures necessary for demobilization and for restoring the navy and army to a peace basis, ministers passed in this year several bills of great importance. Two new ministries were established, one of Health, into which the old Local Government Board was converted and to which were allotted various departments, relating to national health, from other offices; and one of Transport, which was to have control of railways, light railways, tramways, canals and inland navigation, roads, bridges, and traffic generally. Even electricity was included within its general scope; but a special Electricity Supply Bill was passed, constituting commissioners who were to control the supply of electricity for domestic and industrial purposes. It was said in debate that the task of the Transport Ministry would be one for a "superman"; and eventually docks and harbours were exempted from his direct control. Then a Housing Bill was passed, compelling local authorities to provide housing plans; and a scheme was adopted empowering such authorities to issue 5% local bonds; free of income tax for holders of less than £500.

A subsidy of not exceeding £15,000,000 was also provided by Government. There were bills also facilitating the acquisition of land for public purposes, and for the settlement of soldiers and sailors on the land. The emancipation of women, moreover, was practically completed by the passing of a bill providing that no person should be disqualified by sex from the exercise of any public function, or from being appointed to any civil or judicial office or post, or from entering or resuming any profession or vocation. Women were also made eligible as jurors, but the House of Lords still refused to admit women holders of peerages in their own right to sit or vote. At a by-election for Plymouth in Nov. Lady Astor was returned as member in place of her husband, who had succeeded to the peerage, and she was the first woman to sit and vote in the House of Commons. The last Government bill which deserves notice was a Profiteering bill, to endeavour to cope with the great inflation of prices. A central tribunal, presided over by Mr. McCurdy, was set up; and there were also local tribunals, with powers of fining and imprisoning those found guilty before them of undue profit-making.

The object and general tendency of this legislation were greatly to improve the health and social and industrial conditions of the masses of the people; to make, in Mr. Lloyd George's full-blooded phrase, "a land fit for heroes to live in," but at the price of setting up costly new ministries, and a considerable expenditure in rates and taxes. Mr. Chamberlain's budget was conceived on the same large lines. He estimated the expenditure at the gigantic sum of £1,434,910,000, and the revenue on the existing basis of taxation at £1,150,650,000. Therefore, though the war was over, he proposed to increase rather than diminish taxation, except that he reduced the excess profits duty—a war tax *par excellence*—from 80 to 40%. But he greatly increased the taxes on spirits and on beer, and raised the death duties on large estates. The main feature of the budget was the establishment at last of imperial preference, by giving an abatement of a sixth on the duties levied on such imports as tea, coffee, cocoa, sugar, tobacco and motor spirit, and of a third on those levied on cinema films, clocks and watches, motor-cars and cycles. He calculated that, by the changes proposed in taxation, he would bring the revenue up to £1,201,000,000. For the balance he looked to a Victory Loan, which was

Cabinet Government restored.

New Ministries Created.

Special Legislation.

The Budget of 1919.

Restoration of Trade Practices.

Direct Action.

Railway Strike.

The Peace.

sold after Whitsuntide in two forms: (1) 4% Victory Bonds issued at 85 redeemable by annual drawings at par; (2) a 4% funding loan issued at 80 and redeemable within 70 years in the ordinary way. The Labour party, with a portion of the Liberal party, strongly advocated a levy on capital in order to reduce the debt, now £8,000,000,000, to more manageable proportions; but Mr. Chamberlain set his face against it as the greatest possible discouragement of industry and enterprise.

Mr. Asquith and the Independent Liberal party, with some assistance from the Labour men, started a not very formidable agitation in the name of Free Trade against the preferential proposals of the budget. A more effective movement, which gathered force as the year advanced, was that against the extravagant manner in which the Government was carried on. There was a special scandal about a motor-vehicle reception depot which had been established towards the close of the war on 600 ac. of good wheat land at Chippenham, near ~~Chippenham~~, and which was apparently, now that the war was over, being rather extended than curtailed. A select committee of both Houses reported in July that the decision to continue the works after the Armistice had not been justified. Complaint was made of the continuance in peace of war-time naval and military estimates, of war-time ministries, such as Food, Supply and Shipping, and of enormously swollen staffs. It was maintained that it was impossible that the country could go on paying the gigantic taxes and rates which Parliament and the local authorities were exacting, without speedy bankruptcy. Lord Rothermere, who had himself been in charge of a new department during the war, was the protagonist of this movement; and his son, Mr. Esmond Harnsworth, was returned in Nov. to Parliament as primarily an "Anti-waste" member. An increasing section of the press harped on the same theme.

The principle of self-determination, as proclaimed by President Wilson in Paris, produced fermentation in many parts of the British Empire, notably India, South Africa, Egypt and Ireland. In India there was serious trouble in the Punjab, and a regrettable affair at Amritsar; but hope was placed in the Montagu-Chelmsford scheme of reform. In South Africa, fresh life was given to the Hertzog nationalist movement, and the South African party and the Unionists were driven to draw closer together. In Egypt there was violent upheaval, and Lord Milner went out with a special mission to inquire and report. In Ireland

things proceeded from bad to worse throughout the year. Sinn Fein, who had triumphed in the elections, met at Dublin in Jan., appointed an executive, and pledged themselves to the independence of Ireland.

An informal war against all representatives of British authority in the country was begun; and outrages and murders steadily increased, an attack on the life of the Viceroy, Lord French, coming near the end of the year. Meanwhile the Cabinet appointed a committee, of which Mr. (afterwards Lord) Long was chairman, to make representations as to Irish government.

It is pleasant to turn to record the visit in the autumn of the Prince of Wales, first to Newfoundland, then to Canada, and finally to the United States,—each visit, owing to his charm and power of sympathy, proving a bond of union, first of the Empire, and then of the English-speaking peoples. He made another imperial trip in 1920, this time to Australia and New Zealand, with equally happy results; but it was wisely decided that his contemplated visit to India should wait, in view of the strain of the last few years on his strength, till another winter. Another considerable accomplishment of the year 1920 was the passage of a Church Enabling bill, promoted both by the ecclesiastical authorities and by the main body of Church laymen, setting up a National Assembly of the Church of England, which should have some of the powers of independent action always asserted by the Church of Scotland, but subject to the supreme authority of Parliament. The National Assembly in its first meetings in the coming year seemed to justify the hopes formed of it. Though earnest, it was businesslike and not extreme.

The year 1920 opened with the final severance of all direct connexion between the Government and organized labour by the resignation of Mr. Barnes, Minister without portfolio, and of Mr. George Roberts, the Food Controller. These resignations were, however, of small importance by the side of the reappearance of Mr. Asquith in Parliament as member for Paisley. Mr. Asquith's platform was that of a strong opponent to the Coalition, which he said ought now to be dissolved; he advocated Free Trade, retrenchment, and for Ireland Dominion Home Rule. At first it seemed as if he might provide the Government with what they sorely needed, a competent and determined Opposition. But his followers in the House were so few that, after a while, he was discouraged and transferred his main activities to the constituencies, where he succeeded in rallying most of the local Liberal associations to his banner.

The principal matters which occupied the attention of the country in the year were the labour unrest, Ireland, and Government extravagance. Mr. Chamberlain's budget dealt with figures of the same magnitude as in the previous year. In spite of the fact that the estimates for the navy and army showed a diminution of about £340,000,000 compared with those of the previous year, he nevertheless contemplated a total expenditure of £1,418,300,000; and in order that he might make a serious attempt at reducing the weight of the debt, he increased the charges for letters, newspapers and telegrams, and also for receipt and stamp duties; he increased, moreover, still further the duty on beer; doubled that on wine with a special 50% duty on imported sparkling wines; and increased that on cigars. He lowered the limit of exemption from super-tax to £2,000; but made various readjustments of income tax which would ease the burden to the taxpayer of small means, while taxing the rich man still more severely. Finally he imposed a new tax of 12. in the £ on company profits; and raised the excess profits duty (which it had been hoped might be repealed) to 60%. To this last provision most serious exception was taken in the City of London and by the industries of the country; and an agitation was started which did not rest till it had finally secured a promise from the Chancellor to repeal the excess profits tax altogether in the coming year. The general result of the budget was to stimulate the "Anti-waste" party, who began to count seriously in by-elections.

The labour unrest during the year mainly affected the great coal-mining industry, which never settled down during the two and a half years that succeeded the war. It was but a patched-up truce that was arranged after the Sankey Commission, and the men still hankered after higher wages (to correspond with the still rising prices) and for nationalization in some form. The Government absolutely refused nationalization, but promoted a Coal Mines (Emergency) bill which should continue the war pooling arrangements and the Sankey wage till the termination of State control. This did not at all content the men, who demanded in March an immediate advance of 3s. per shift for miners over 16, and of 1s. 6d. below that age. After many negotiations the Government made a proposal of a guaranteed minimum advance of 2s. for adults, 1s. for youths between 16 and 18, and 9d. for boys under 16. This was accepted on ballot in April. It was estimated that this concession implied an extra charge of more than £30,000,000 a year on the industry; the surplus available to meet it being only about £8,000,000. The Government passed, this session, a Mining Industry Bill, constituting a Department of Mines under the Board of Trade, dropping their original and wasteful idea of constituting a brand new ministry. This was unpopular among the miners, and perhaps contributed to the new demand sprung in Aug. on the Government. In 1920 ministers had had unfortunate dealings with the price of coal. In July of that year they had increased the price by 6s. a ton on the reasonable ground that this was the necessary result of the increased wages granted in accordance with the Sankey report. Then suddenly in Nov. they decreased the price of domestic coal by 10s. on the ground that it was felt that the consumer should share in the large profits which, owing

to the high prices ruling in America, were made on exported coal. But this could not be maintained, and in May 1920 the price of domestic coal was raised by 1s. 2d. a ton, and that of industrial coal by 4s. 2d. In view of these facts the miners at the end of July 1920 coupled with a demand for a further advance of 2s., 1s. and 9d. a shift for the three grades, a demand for a reduction of price to the consumer of 14s. 2d. a ton. It was thought that this bribe would make the public sympathetic to their claims. The calculation was that the increase of wages

would cost the industry £27,000,000, and the reduction of price would add another £36,000,000,—thus more than accounting for the £60,000,000 made by the Government as profits on exported coal, and badly needed by them for their general revenue. These demands the Government absolutely declined to entertain; and on a ballot near the end of August the miners determined to strike in order to obtain them. But the opening of the strike was postponed for more than a month and a half, pending a series of negotiations between the Government, the representatives of the owners and the Miners' Federation, and also the spokesmen of the railway men and of the transport workers, who intervened as members of the Triple Alliance to support the miners' claims. Nationalization, though Mr. Smillie, one of the leaders, said the miners would never rest till they got it, was not actually claimed on this occasion; the altruistic demand for a large reduction of the price of coal to the consumer was soon dropped, and the struggle became one merely for increased wages—a claim based by the miners on the still rising prices. The Government and the owners pointed out that, since the increases in wages under the Spanke award, output had decreased,—and maintained that increase in wages would only be justified by increase of output. The miners insisted on an advance of 2s. as a preliminary, and the strike began in the middle of October and lasted a fortnight. The National Union of Railway Men threatened to strike in support of the miners, but it is doubtful whether the railway men themselves would have come out in any number. The question was never put to the test, as a provisional arrangement was come to, and confirmed on ballot, by which the miners got their 2s. a day (and could get more by increased output) till Jan. 3, after which wages were to be governed by a sliding scale, ultimately to be superseded by an agreed scheme for their permanent regulation. Sir Robert Horne, who, with the Prime Minister, bore the brunt of these negotiations, greatly enhanced his reputation by his firmness, adroitness and geniality.

There were disputes in the cotton and engineering and other trades during the year, but nothing comparable to that in the coal industry. Organized labour, which had been very sensitive since the Russian Revolution of any attempts to interfere in its arms with the Soviet Government, formed, in this summer of 1920, in view of the strained relations between Poland and Russia, a Council of Action to prevent any such interference, with the implied threat of a general strike at its back. This unconstitutional proceeding was justified in a half-hearted manner by the moderate leaders, Mr. J. H. Thomas and Mr. Clynes. But the French Government refused to allow delegates of the Council of Action to remain in France; and, as an independent Poland and peace with Russia were soon seen to be secured, Mr. Thomas discreetly buried the Council with an appropriate eulogium at the Trade Union Congress. The financial offers made by the Bolsheviks to the Daily Herald, the labour organ, which were revealed in the autumn, added to the growing discredit of Bolshevik rule in Labour eyes.

The war of murder and outrage waged by civilian Republicans in Ireland against the civil and military forces of the Crown, and against prominent loyalists in all parts of the south and west, was intensified from the beginning of the year onwards. To meet the crisis the Royal Irish Constabulary were increased, an auxiliary force of cadets, mainly young English officers who had served in the war, was created, and the troops reinforced. In August Sir Hankey Greenwood, who had succeeded Mr. Macdonnell in April as Chief Secretary, hurried through Parliament a Restora-

tion of Order in Ireland bill which provided for the suspension of trial by jury in disturbed areas and the substitution of trial by court martial. The strain of outrage and assassination to which military and police were subjected proved too much for the nerves of some members of the forces of order, especially among the insufficiently disciplined auxiliaries; and in a considerable number of cases unauthorized reprisals were carried out, in which individuals, not always guilty, were shot, and dwelling-houses and shops and warehouses and creameries were sacked and burnt. The British public, as a whole, was so conscious of the widespread conspiracy and the appalling crimes that had to be faced and got under by inadequate but courageous forces, that it was disposed to condone occasional acts of reprisal, provided that due efforts were made by the authorities to restore and enforce discipline. That was eventually done and certain definite reprisals authorized in definite cases, but not until after a delay of several months, during which Mr. Asquith and Sir John Simon and the Independent Liberals in general, with the aid of some bishops and other ministers of religion, conducted a violent agitation against the misdeeds of a small portion of the forces of the Crown—in which the crimes and the "war" against which these forces were struggling, seemed to be unduly disregarded. The police and troops were successful in so far that they prevented Sinn Féin officers and tribunals from functioning openly, as heretofore, in many parts of the south and west. But, in spite of occasional boasts by ministers, like Mr. Lloyd George's assertion at Gullihall on Lord Mayor's day "We have murder by the throat," crime was not stopped, and there was little improvement in the state of the southern and western provinces by the summer of 1921. Indeed the "war" was carried in the spring of 1921 into England; and in Liverpool and the neighbouring country, and in London and the Home Counties, outrages were committed.

It was not merely by force that the Government proposed to meet the crisis in Ireland. The conjunction of Unionists and Liberals in one coalition seemed to give an opportunity for an agreed settlement of the Home Rule dispute. As a result of the labours of the Cabinet Committee presided over by Mr. Lough, the Government introduced in Feb. a Home Rule bill of a novel character. It provided for the establishment of two Irish Parliaments, one in Belfast, for the six north-eastern counties, and one in Dublin for the remaining counties, and of a Council of Ireland "with a view to bringing about harmonious action between the Parliaments and Governments of Southern Ireland and Northern Ireland." The Council was to consist, in the first instance, of a President appointed by the King, and of delegations of 20 members of each of the two Irish Parliaments; but the two Parliaments might vary its constitution, and provide for it being elected by Parliamentary electors. Further, the two Irish Parliaments had power given them to establish, in place of the Council of Ireland, a Parliament for the whole of Ireland, consisting of one or two Houses. This bill, which recognized the necessity of partition for the present, made provision for unity in the future. As originally drafted, the bill provided only for one House, a House of Commons, in each area; but the Lords added a Senate in each case, which the Government accepted. The executive power in the two areas was to continue vested in the King, who might delegate his authority to the lord lieutenant. The number of Irish members of Parliament at Westminster was to be 42. Of the Irish contribution of £18,000,000 a year to Imperial expenditure, 50% was apportioned to Southern, and 44% to Northern Ireland. There was to be a separate judiciary in each area, with a High Court of Appeal for the whole of Ireland. The powers reserved for the Imperial Parliament were roughly those reserved under the Act of 1914 which Mr. Redmond had accepted, save that further taxes were placed at the disposal of the two Parliaments; and in case of an Irish Parliament being constituted full powers over customs and excise were to be extended to it. The southern Parliament refused to function, that part of Ireland was to be governed as a Crown colony. The reception of the bill was very unfavourable in southern and western Ireland, by Nation-

alists and Sinn Feiners. It was a scheme, said the *Freeman's Journal*, for the "plunder and partition" of Ireland. Protestant Ulster, after a little hesitation, took the line that she was quite satisfied with her present position in the United Kingdom, but that, if Parliament thought such a measure right, she would accept it and do her best to make it a success. The bill was opposed, on the ground that it involved partition, both by the Labour party, who were prepared to concede the absolute right of self-determination, and by Mr. Asquith, who proclaimed his adherence to a Dominion Constitution. That also was the view of Sir Horace Plunkett; and several southern Unionists, such as Lord Dunraven and Lord Middleton, demanded complete fiscal autonomy for Ireland. The bill eventually passed into law in Dec. 1920, and was put into force in 1921. Lord Edmund Talbot, who

**Bill Passed and Elections Held.**

became Viscount Fitzalan, an English Roman Catholic, was appointed Lord Lieutenant, and elections were duly held for the two Parliaments in the spring. As the campaign of Sinn Fein terrorism was still in full swing in southern Ireland, Sinn Feiners were everywhere returned in that area unopposed, save in Trinity College. In northern Ireland the Unionists had a great electoral success, returning 40 out of the 52 members of the new House of Commons. As Sir Edward Carson had retired and taken a Lordship of Appeal, Sir James Craig was the Unionist leader, and formed a Government as Prime Minister. The King and Queen opened the

**The King and Queen.**

Ulster Parliament in state on June 22, the King, in moving language, expressing the hope in his Speech from the Throne that Irishmen would forgive and forget. Thereupon Mr. Lloyd George, while making every arrangement for strengthening the authority of the Crown in southern Ireland against the forces of disorder, issued a public invitation to Mr. De Valera, the Sinn Fein leader, and to Sir James Craig, to come and confer with him at once in London without conditions. Sir J. Craig accepted immediately; and Mr. De Valera, after consulting with other Sinn Fein leaders and with some of the southern Unionists, also came to London; while a truce was called in the "war" (see further the article IRELAND).

Several important changes took place in the Ministry in the early months of 1921. Mr. Long retired from the Admiralty for ill health and was subsequently created a viscount. Lord Milner, after remarkable service to the State, resigned the Colonial Office, and retired into private life, being succeeded by Mr. Churchill. Mr. Bonar Law had a sudden breakdown, which entailed immediate abandonment of political work, and which, as he was one of the main pillars of the Coalition, might well result in serious political complications. But Mr. Austen Chamberlain was immediately elected by the Unionist party to be leader in the House of Commons in his place; and he stepped into the same confidential relation that Mr. Law had held in regard to the Prime Minister. He became Lord Privy Seal. Sir Robert Horne succeeded him as Chancellor of the Exchequer, and was succeeded at the Board of Trade by Mr. Stanley Baldwin. The Government bills which attracted most attention in this session were one by Sir Eric Geddes for grouping the railways of the country in the interests of efficiency and economy; and another promoted by the Board of Trade for the safeguarding of special industries. The Independent Liberals, in their opposition to the Protection which they discovered in this latter bill, made use of the well-known arts of obstruction, and all-night sittings were resumed. The budget dropped the excess profits duty, and the higher rates of duty imposed in the previous year on sparkling wine and cigars. Postal rates were however further increased. Otherwise taxation remained at the same height.

**Highly Successful Changes in 1921.**

This heavy burden was more felt this year, because the period of inflated trade which had succeeded the war had come to a sudden end in the previous autumn; prices tumbled down; it was impossible to find markets for goods; wages had to be reduced and men dismissed in one great industry after another; and unemployment steadily increased. It was borne forcibly in upon every individual that economy in public and private expenditure was imperative.

**Depression in Trade.**

By-elections, as might be expected with so huge a majority, had on the whole gone against the Government from the beginning. But their losses this spring and early summer had this exceptional character, that the victors in the three contests which attracted most attention, at Dover, St. George's (Westminster) and East Herts., ran simply and purely as "Anti-waste" candidates. The tendency of the Government, already manifested, to restrict its ambitions and curtail its schemes, was intensified. Already practically all the new war ministries, except the Pensions Ministry, had been disbanded; the putting into complete effect of Mr. H. A. L. Fisher's comprehensive but somewhat extravagant Education Act had been postponed; and urgent admonitions in favour of economy had been circulated to the departments. Now it was announced by Mr. Churchill that he had formulated a scheme by which the enormous outlay in Mesopotamia and Palestine, against which there had been a great public outcry, might be materially reduced. Dr. Addison, who was thought to have studied thoroughness rather than economy in regard to his housing schemes and his medical staff at the Ministry of Health, resigned that Ministry; and so strong a protest was roused by his retention in the Cabinet without a portfolio but with a salary, that the Prime Minister felt it necessary in June to declare that the arrangement was only for the remainder of the session, and that the salary would be halved. Dr. Addison's successor in the Ministry of Health, Sir Alfred Mond, announced an administration on much less ambitious lines. Ministers also abandoned their guarantee of agricultural prices and wages; and further determined to terminate their control of the coal industry on April 1, four months earlier than the date originally announced. This resulted in yet another coal strike, or stoppage, the most serious of all the strikes in the industry in these years. The men could not reconcile themselves to the great reductions in wages necessary to make the industry self-supporting. And they also demanded a national pool—a half-hearted form of their old demand for nationalization. They alienated public sympathy at first by withdrawing the pump men from the mines—a position from which they had to recede. The Government offered a temporary subsidy of £10,000,000 to tide over the difficult early weeks; but terms could not be arranged, and the strike lasted for three months—April, May and June,—and was settled in the end on terms which the men might have had early in the dispute, if they had not clung to the national pool, which of course had to be abandoned. The loss to the country was enormous, as the great industries dependent upon coal had one after another to close down their works. But the employers in these industries could support the stoppage better than the men, as, owing to the depression of trade, they would have been manufacturing during these months at a loss. The funds of the great unions were depleted, and many of them got deeply into debt; and there was some want and hardship amongst women and children. Happily, it was a season of warmth and brilliant sunshine, so that the domestic fire was needed only for cooking.

A momentous conference was held in London in the summer of 1921 between the Prime Ministers of the United Kingdom, the Dominion of Canada, the Commonwealth of Australia, the Dominion of New Zealand and the Union of South Africa, together with representatives of India. The main object of the conference was to formulate a common foreign policy for the sister nations composing the British Empire, and to come to a decision as to the renewal of the Anglo-Japanese alliance (see BRITISH EMPIRE).

There were symptoms of uneasiness in the latter part of 1920 and in 1921 in the extreme wings of both parties to the Coalition. On the one hand there was some fraternizing between Independent and Coalition Liberals; and on the other Lord Salisbury was the spokesman of those Tories who urged Unionists to come out of the Coalition and resume their independence, a course which had already been taken by a few individuals, conspicuous among whom were his brothers, Lord Robert and Lord Hugh Cecil. But neither move-

**Government Responds to Criticism.**

**Coal Stoppage of 1921.**

**Empire Conference in Conference.**

**Finality of Parties in 1921.**

ment appeared to be strongly supported, though much greater independence had been shown of late by the Ministerial majority in the House of Commons. The Labour party, though alternately upbraided and cajoled by the Independent Liberals, showed no disposition to enter into a political compact with them; and without such an arrangement it did not look as if Mr. Asquith and his friends could command anything approaching adequate support in the country to regain office. Many Liberals indeed had gone over to Labour; but the Labour party, whose programme demanded a continuance of heavy expenditure and therefore high taxation, were for the time out of accord with public sentiment.

Mr. Lloyd George, in spite of virulent abuse, partly political, partly personal, still remained throughout 1921 by far the greatest individual force in the country. He strengthened his position, indeed, from every point of view but one, by the course of events during the closing months of the year. The fact that, after general expectations of a break-down in the Irish negotiations, the conference which began in London in October between delegated representatives of Sinn Fein and the Government ended on Dec. 6 in a unanimously signed agreement for the setting-up of an Irish Free State, was a great personal triumph for his patient diplomacy. Though he was too much engaged in this matter to be able, as he had intended to do, to attend the Conference for the Limitation of Armament held in Washington, at which Mr. Balfour took his place, the Prime Minister could claim for his Government a very satisfactory issue from the Conference, to the initiation of which by President Harding and his Secretary of State, Mr. Hughes, Mr. Lloyd George himself had given the strongest encouragement earlier in the year. Incidentally, the question of a prolongation of the Anglo-Japanese alliance—which had been a difficult point at the Imperial Conference in the summer—was successfully removed by the substitution of the Four-Power Agreement adopted in Washington; and thus Mr. Lloyd George had the satisfaction of clearing away two important obstacles to the consolidation of the Anglo-

American *entente* for which he was always striving in international affairs.

The only point of view from which Mr. Lloyd George's indispensability at this moment as Prime Minister could be said, therefore, to have been weakened was that of his success. Paradoxically enough, the mere fact that his long struggle to reconcile Irish national aspirations with inclusion within the British Empire had at last been rewarded might appear to leave him no longer *l'homme nécessaire* for that purpose. How far this possibility might react on the political situation, in the later re-grouping of parties, had now to be shown. But individually Mr. Lloyd George, at the end of 1921, held the dominating place among political leaders. Mr. Asquith had lost his hold both over the country and over his old party. The Labour party, though practically certain of a large increase in Parliamentary representation whenever the country should be appealed to, had several prominent leaders but no really outstanding chief. The Conservatives, as such, were without any striking personality; Mr. Austen Chamberlain had shown no disposition to break away from the alliance with Mr. Lloyd George, and Mr. Bonar Law, though his health was restored, had ignored every suggestion so far that he should return to the political arena as an independent Conservative leader. Among the rest, the only men whose reputations had notably grown in 1921 were Lord Birkenhead and Mr. Churchill; and it was to them, either in rivalry or in combination, that current political talk usually pointed, should occasion arise for alternatives to a Lloyd George Ministry. As Lord Chancellor, Lord Birkenhead had won golden opinions on all sides, and he had never shown his capacity for statesmanship more prominently than during the past year, when he had put all his pre-war record as an aggressive sympathizer with Ulster aside in helping to secure an agreement with Sinn Fein. He and Mr. Churchill were still sufficiently young, as well as able and experienced, to make their political futures incalculable. (G. E. B.)













32101 064517483











32101 064517483



32101 064517483

DATE ISSUED	DATE DUE
MAR 18	



~~Forrestal  
ANNEX  
Spring, 1984~~  
Digitized by Google

