

NEW AGE

SECOND EDITION

MANUFACTURING PROCESSES



H.N. Gupta • R.C. Gupta • Arun Mittal



NEW AGE INTERNATIONAL PUBLISHERS

MANUFACTURING PROCESSES

**This page
intentionally left
blank**

MANUFACTURING PROCESSES

(SECOND EDITION)

H.N. Gupta

B.Sc., G.I. Mech.E (London), FIE

Visiting Professor

Department of Mechanical Engineering
I.E.T., Lucknow, U.P. Technical University

R.C. Gupta

B.Sc., B.E., M.Tech., Ph.D.

Professor and Head

Department of Mechanical Engineering
I.E.T., Lucknow, U.P. Technical University

Arun Mittal

Senior Faculty

Department of Mechanical Engineering
I.E.T., Lucknow, U.P. Technical University



PUBLISHING FOR ONE WORLD

NEW AGE INTERNATIONAL (P) LIMITED, PUBLISHERS

New Delhi • Bangalore • Chennai • Cochin • Guwahati • Hyderabad
Jalandhar • Kolkata • Lucknow • Mumbai • Ranchi

Visit us at www.newagepublishers.com

Copyright © 2009, New Age International (P) Ltd., Publishers
Published by New Age International (P) Ltd., Publishers

All rights reserved.

No part of this ebook may be reproduced in any form, by photostat, microfilm, xerography, or any other means, or incorporated into any information retrieval system, electronic or mechanical, without the written permission of the publisher. *All inquiries should be emailed to rights@newagepublishers.com*

ISBN (13) : 978-81-224-2844-5

PUBLISHING FOR ONE WORLD

NEW AGE INTERNATIONAL (P) LIMITED, PUBLISHERS

4835/24, Ansari Road, Daryaganj, New Delhi - 110002

Visit us at www.newagepublishers.com

Preface to the Second Edition

The authors of the book “Manufacturing Processes” are thrilled at the speed with which the first edition of the book has been snapped up and exhausted within four months of its publication necessitating a reprint. This proves that the book has been found useful both by teachers and the students. This is extremely gratifying.

It has been felt that to make the text of the book even more useful, certain changes have been made. Therefore the text of the Unit I and Unit IV has been completely rewritten in the second edition of the book. However, the essential features of the book have not been altered. The text is in simple narrative style and does not presume any preliminary knowledge of the subject matter. The text is neither too detailed, nor has any essential information been left out. The text is amply illustrated.

To make the book even more useful, the question bank has been widened and a number of questions of objective type have been added unitwise at the end of each unit.

It is the author’s belief that this second edition of the book will be found extremely useful by both the faculty and the students.

AUTHORS

**This page
intentionally left
blank**

Preface to the First Edition

The 'driving force' behind a 'technological revolution' has always been a certain 'material'. There would have been no 'industrial revolution' without 'steel' and no 'electronic/computer revolution' without 'semiconductor'. Similarly the 'key' behind 'socioeconomic development' is the 'manufacturing' which is done by certain manufacturing processes using certain materials. Moreover, the primary duty of engineers is to make life-style of people more easy and comfortable, engineers do this by 'making' certain tools and things through certain manufacturing processes using certain material of desirable property.

The present book on 'Manufacturing Processes' is what every engineer, irrespective of branch or specialization, should know. Note that this book is not a book on 'Workshop' Technology'. 'Workshop Technology' is usually taught as 'Workshop-Practice' usually with 0-1-3. L-T-P, meaning by 3-lab hours and 1 hour for tutorial (or lecture) for the theory of workshop tools & processes.

The book on 'Manufacturing Processes' covers a wide overview of 'material', manufacturing processes' and other 'misc. topics'.

Unit-I deals with Basic-Metals & alloys: Properties and Applications. Units-II and III cover major manufacturing processes such as Metal Forming & Casting and Machining & Welding. The last Unit-IV covers misc. and left-over but relevant topics. The details of topics are given in the syllabus and on the content pages.

The book is intended for engineers of any specialization to present an overview of manufacturing process and the material used in it. The book would be useful as a core-course to B.Tech. students of all branches and all universities throughout the world.

The book is considered to be useful universally, specially in view of syllabus of 'Manufacturing Processes'.

AUTHORS

**This page
intentionally left
blank**

Contents

<i>Preface to the Second Edition</i>	v
<i>Preface to the First Edition</i>	vii

Unit I

BASIC METALS AND ALLOYS : PROPERTIES AND APPLICATIONS

1	PROPERTIES OF MATERIALS	3-10
	Introduction	3
	Properties of Materials	3
	Stress-Strain Diagram	3
	Malleability and Ductility	6
	Brittleness	6
	Stiffness and Resilience	6
	Toughness and Impact Strength	6
	Hardness	7
	Fracture of Material	8
	Fatigue Failure	9
	Creep Failure	9
	Questions	10
2	FERROUS MATERIALS	11-18
	Introduction	11
	Iron and Steel	11
	Classification of Steels	11
	Wrought Iron	13
	Cast Iron	13
	Alloy Steels	15
	Heat Treatment of Carbon Steels	17
	Questions	18

3	NON-FERROUS METALS AND ALLOYS	19-25
	Introduction	19
	Properties and Uses of Non-Ferrous Metals	19
	Alloys of Copper	20
	Cupro-Nickels	22
	Aluminium Alloys	22
	Alloys of Nickel	22
	Questions	23
	<i>Objective Type Questions</i>	24-25

Unit II

INTRODUCTION TO METAL FORMING AND CASTING PROCESS

1	BASIC METAL FORMING PROCESSES AND USES	29-33
	Introduction	29
	Advantages of Mechanical Working Processes	29
	Difference Between Hot and Cold Working	30
	Advantages and Disadvantages of Cold and Hot Working Processes	31
	Classification of Metal Forming Processes According to Type of Stress Employed	32
	Questions	33
2	FORGING	34-44
	Introduction	34
	Classification of Forging	34
	Die Forging with Power Hammers	40
	Open Die Forging	40
	Impression Die Forging	41
	Closed Die Forging	41
	Drop Stamping or Drop Forging Hammers	41
	Some Important Considerations Leading to Sound Forgings	42
	Forging Presses	42
	Machine Forging	42
	Forging Defects	43
	Heat Treatment of Forgings	43
	Cold Forging	44
	Questions	44
3	ROLLING	45-56
	Introduction	45
	Nomenclature of Rolled Products	46
	Mechanism of Rolling	46

	Types of Rolling Mills	48
	Rolls and Roll Pass Design	50
	Ring Rolling	51
	Cold Rolling	52
	Rolling Defects	53
	Questions	56
4	EXTRUSION, WIRE DRAWING, TUBE DRAWING AND MAKING	57-65
	Extrusion Processes	58
	Machines for Extrusion	62
	Extrusion Defects	62
	Wire Drawing	62
	Tube Drawing	63
	Tube Making	64
	Questions	65
5	PRESS WORK AND DIE-PUNCH ASSEMBLY	66-72
	Tools	66
	Other Operations Performed with Presses	68
	Bending	68
	Deep Drawing	69
	Coining and Embossing	70
	Coining	70
	Guillotine Shear	71
	Questions	72
6	CASTING PROCESS	73-85
	Introduction	73
	Patterns	74
	Pattern Allowances	74
	Types of Patterns	74
	Moulding Sand and its Properties	76
	Mould Making Technique	77
	Cores	79
	Core Prints	79
	Gates, Runners and Risers	80
	Cupola	81
	Construction	81
	Operation of Cupola	82
	Casting Defects	82
	Die Casting	83

Steps in Die Casting.....	84
Questions	85
<i>Objective Type Questions</i>	86–87

Unit III

INTRODUCTION TO MACHINING AND ITS APPLICATIONS

1	LATHE	91–99
	Introduction	91
	Centre Lathe.....	92
	Cutting Tools Used on the Lathe	94
	Holding the Work Piece in the Chuck and Centering	95
	Taper Turning	96
	Profile or Form Turning	98
	Questions	99
2	SHAPERS AND PLANERS	100–105
	Introduction	100
	Shaping Machines or Shaper	100
	Drive	101
	Cutting Tools Used in Shaping	102
	Operations Performed on Shapers	102
	Planer or Planning Machine	104
	Principle of Working	104
	Questions	105
3	DRILLING MACHINES	106–110
	Twist Drill	106
	Drilling Machines	107
	Questions	110
4	MILLING PROCESS	111–119
	Introduction	111
	Basic Milling Process	111
	Types of Milling Processes	112
	Peripheral Milling	113
	Face Milling	115
	End Milling	116
	Milling Machines	117
	Horizontal Milling Machine	117
	Questions	119

5	GRINDING PROCESS	120-126
	Introduction	120
	Choice of Abrasives	120
	Classification of Wheels	121
	Grit	121
	Bond and Grade	121
	Wheel Structure	121
	Wheel Shapes	122
	Mounting a Wheel on Machine, Balancing, Truing and Dressing	123
	Grinding Operations and Grinding Machines	123
	Coolant	126
	Questions	126
6	WELDING PROCESS	127-141
	Classification	127
	Gas Welding Process	127
	Equipment Needed for Gas Welding	128
	Types of Flames	130
	Welding Operation	130
	Use of Filler Rods and Fluxes	133
	Oxyacetylene Cutting	133
	Arc Welding	133
	Striking an Arc	134
	Heat Affected Zone	135
	Arc Blow	135
	Welding Positions	135
	Arc Welding Defects	136
	Electric Resistance Welding	136
	Soldering and Brazing	140
	Soldering Process	140
	Brazing Process	140
	Questions	141
	<i>Objective Type Questions</i>	142-143

Unit IV
MISCELLANEOUS TOPICS

1	IMPORTANCE OF MATERIALS AND MANUFACTURING	147-153
	Introduction	147
	Proper Selection of Material	147
	Importance of Materials	148

	Historical Perspective	149
	Materials as Driving-Force Behind Technological Developments	149
	Direct and Indirect Linkages Among Materials, Manufacturing, Technological Development and Socioeconomic Improvement	152
	Conclusion	152
	Questions	153
2	LOCATION AND LAYOUT OF PLANTS, PRODUCTION AND PRODUCTIVITY	154–157
	Introduction	154
	Location of Plants	154
	Layout of Plants	155
	Advantages of a Good Layout	155
	Types of Layouts	155
	Types of Production	156
	Production and Productivity	157
	Questions	157
3	NON-METALLIC MATERIALS	158–167
	Common Types and Uses of Wood	158
	Uses of Wood	159
	Cement Concrete	159
	Ceramics	160
	Rubbers	160
	Plastics	162
	Composite Materials	165
	Questions	167
4	MISCELLANEOUS PROCESSES	168–173
	Powder Metallurgy Process	168
	Plastic Products Manufacturing Processes	169
	Galvanising Process	171
	Electroplating Process	172
	Faraday's Laws of Electrolysis	173
	Questions	173
	<i>Objective Type Questions</i>	174–175
	QUESTION PAPER	177–179

UNIT I

Basic Metals and Alloys : Properties and Applications

**This page
intentionally left
blank**

Properties of Materials

INTRODUCTION

Materials are the driving force behind the technological revolutions and are the key ingredients for manufacturing. Materials are everywhere around us, and we use them in one way or the other. The materials and the manufacturing process employed, could be better appreciated if one understands various types of materials and its properties.

PROPERTIES OF MATERIALS

Properties of materials include mechanical properties (such as strength, hardness, toughness), thermal properties (conductivity), optical properties (refractive index), electrical properties (resistance) etc. Here, however, we shall concentrate only on mechanical properties which are most important in manufacturing processes and also in everyday life and we use these terms quite often. To understand the mechanical properties, it is useful to first understand the behaviour of the material when subjected to a force which causes deformation; this could be understood with the ‘stress-strain diagram’.

STRESS-STRAIN DIAGRAM

Consider a rod of initial length L_0 and area A_0 which is subjected to a load F . The stress σ is the force per unit area, and strain ϵ is the change in length (δ) divided by the initial length. Thus,

$$\text{Stress } \sigma = F/A_0$$

$$\text{Strain } \epsilon = \delta/L_0$$

The σ - ϵ curve for a material (say mild steel) is shown in the Fig. 1.1. Up to the proportionality point A , the stress-strain variation is linear. Up to this point Hooke’s law holds good.

i.e., $\sigma \propto \epsilon$

or $\sigma = E\epsilon$

where E is the Young’s modulus commonly called modulus of elasticity.

Beyond point A and up to point B , material remains elastic *i.e.*, the material returns to its original condition of the forces acting on it is removed.

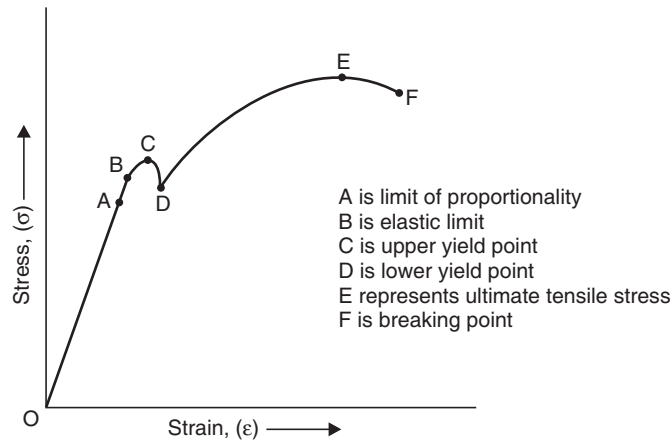

Fig. 1.1 Stress-strain curve for ductile material

If the specimen is stressed beyond point *B*, permanent set takes place and we enter plastic deformation region. In the plastic deformation region, the strain does not get fully removed even with the removal of the force causing it. If the force is increased further, point 'C' is reached where the test specimen stretches even when the stress is not increased. This point is called yield point. Infact, there are two yield points *C* and *D* which are called upper and lower yield points respectively.

With further straining, the effect of a phenomenon called strain hardening or work hardening takes place.* The material becomes stronger and harder and its load bearing capacity increases. The test specimen is therefore able to bear more stress. On progressively increasing the force acting on the specimen, point *E* is reached. This point is the highest point in the stress-strain curve and represents the point of maximum stress. It is, therefore, called ultimate tensile strength (UTS) of the material. It is equal to the maximum load applied divided by the original cross-sectional area (A_0) of the test specimen.

Here, we must consider the effect of increasing load on the cross-sectional area of the test specimen. As plastic deformation increases, the cross-sectional area of the specimen decreases. However for calculation of the stress in the stress-strain graph, the original cross-sectional area is considered. It is for this reason, that the point of breakage *F* seems to occur at a lower stress level than the UTS point *E*. After UTS point *E*, a sharp reduction in cross-sectional area of the test specimen takes place and a "neck" is formed in the centre of the specimen. Ultimately the test specimen breaks in two pieces as the neck becomes thinner and thinner. The actual breaking stress is much higher than the UTS, if the reduced cross-sectional area of the test specimen is taken into account.

The measure of the strength of a material is the ultimate tensile strength (σ at point *E*). However, from the point of view of a design engineer, the yield point is more important as the structure designed by him should withstand forces without yielding. Usually yield stress (σ at point *D*) is two-thirds of the UTS and this is referred to as yield-strength of the material.

In actual practice, to determine UTS, a tensile test is carried out on a tensile testing or a universal

*This phenomenon is more fully described in Unit II, Chapter 1.

testing machine. In order that tests conducted in different laboratories on the same material may give identical test results, the test piece used for the tensile test has been standardised. A standard test piece is shown in Fig. 1.2.

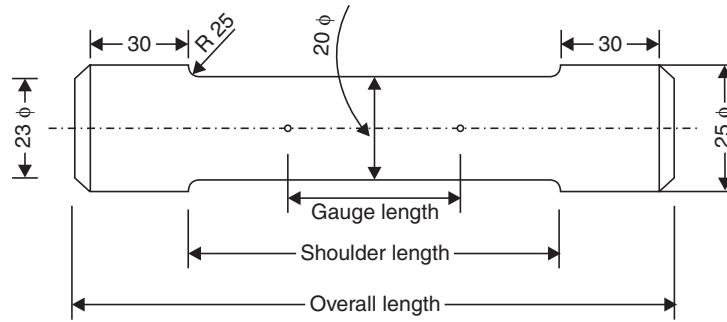

Note: Gauge, shoulder and overall lengths according to IS : 210-1978.

Fig. 1.2 Dimensions of a standard tensile test-piece

A stress-strain curve for brittle material is obtained by subjecting a test bar of such material in a tensile testing machine. The tensile load is gradually increased and the extension of the test piece is recorded. The stress-strain curve for a brittle material shows some marked differences as compared to the curve obtained for a ductile material. A typical stress-strain curve for a brittle material is shown in Fig. 1.3.

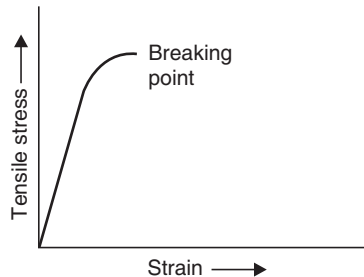

Fig. 1.3 Stress-strain curve for brittle material

This curve displays no yield point, and the test specimen breaks suddenly without any appreciable necking or extension. In the absence of a yield point, concept of “proof-stress” has been evolved for measuring yield strength of a brittle material. For example, 0.2% proof-stress indicates the stress at which the test specimen ‘suffers’ a permanent elongation equal to 0.2% of initial gauge length and is denoted by $\sigma_{0.2}$.

The tensile test and the stress-strain curve has been described above in some detail, because a lot of useful information with regard to other properties of material can be gleaned from it. It may be noted that most tensile testing machines are provided with equipment to carry out a compressive strength test as well.

MALLEABILITY AND DUCTILITY

Both these properties relate to the plasticity of the material. Malleability refers to the ability of plastic deformation under compressive loads, while ductility refers to plastic deformation under tensile loads. A malleable material can be beaten into thin sheets and even thinner foils. A ductile material can be drawn into wires.

A measure of ductility is “percentage elongation”. Before the tensile test begins two punch marks are made on the stem of the tensile test piece. Distance between these marks is noted and is known as gauge length (l_0). After the tensile test piece fractures in two pieces, the two pieces are retrieved and placed together as close to each other as possible. Now the distance between the two punch marks is measured and noted again. Let this distance be l_1 . The % elongation is calculated as

$$\frac{l_1 - l_0}{l_0} \times 100$$

High values of percentage elongation indicate that material is very ductile. Low values indicate that material is brittle and has low ductility. For mild steel, the percentage elongation usually is 20% or more.

BRITTLINESS

Brittleness can be thought of as opposite of ductility. It is a property which is possessed in great measure by glass and other ceramics. A piece of glass, if dropped on a hard surface shatters and is broken in many pieces. The real cause of brittleness is inability of the material to withstand shock loads. Of course, glass is an extreme case of brittle material.

STIFFNESS AND RESILIENCE

A material with high value of modulus of elasticity is said to be stiff and a material with low value of modulus of elasticity is said to be resilient. Consider a material undergoing tensile stress within the elastic range. If the material possesses a high value of Young’s modulus (which is the modulus of elasticity corresponding to tensile stress), the material will not stretch much. It will behave as a “stiff” material. In this case, the slope of the line OA (Fig. 1.1) will be more. Resilience is a property which is totally opposite to stiffness. A beam made of stiff material will deflect to a lesser extent as compared to another made of resilient material under identical loading condition.

TOUGHNESS AND IMPACT STRENGTH

Toughness and impact strength are allied or similar properties (although these are some differences as mentioned later). They represent the ability of the material to absorb energy before actual failure/fracture occurs. Refer to Fig. 1.1. If the scale of y -axis is changed and if force is plotted on this axis and, if actual elongation is plotted on x -axis instead of strain, we shall obtain a force-elongation curve instead of stress-strain curve. The shape of curve will remain the same; only scales of x and y axes will change. Now the area under this curve will represent energy required to fracture the material. Higher

the energy, higher is the toughness of material. Toughness comes from a combination of strength and percentage elongation. Since this property enables a material to withstand both elastic and plastic strains, it is considered very important.

Higher impact strength goes with higher toughness. In actual impact testing, loads used are dynamic loads and the load is directed to the specimen through a sharp notch. Two tests have been standardised to measure the impact strength of a material (as also its toughness). These tests are called (i) IZOD test, and (ii) Charpy test. IZOD test is described below in brief.

A standardised test specimen is shown below in Fig. 1.4 (a).

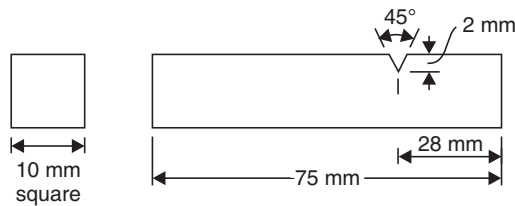

Fig. 1.4 (a) IZOD test specimen

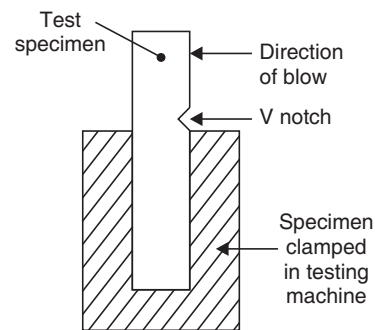

Fig. 1.4 (b) Specimen fixed in IZOD testing machine

This specimen is fixed in the IZOD testing machine in a vertical position as shown in Fig. 1.4 (b). A blow from a swinging pendulum falling from a specified height is then struck on the test specimen 22 mm above the notch. The mass of the pendulum is known. Since height from which pendulum descends down to strike the blow is also known, we know the energy stored in the pendulum ($m.g.h.$).

After striking the test piece and fracturing it at the notch, the pendulum moves on and the height to which it rises on the otherside of the test piece is noted and measured. Thus the energy still left in the pendulum can be calculated. The difference between the original energy in the pendulum and the energy left over after breaking the test specimen is assumed to have been used up in breaking the test specimen. This is taken as the impact strength of the material of the specimen. A correction factor for friction at pendulum bearing is applied to get accurate result.

A brittle material has low impact strength and poor toughness.

HARDNESS

Hardness is a very important property of materials. Hardness indicates wear-resistance and resistance against abrasion or scratching. A hard material also offers resistance to penetration by another body. In the olden days, a scale of hardness was established and diamond, which is the hardest known material was put on top of this scale. Glass and other materials were put lower down on this scale. The criterion used was a simple scratch test. If a material could scratch another material, then the former was considered harder than the latter material and was placed higher in the scale of hardness.

In modern times, several tests for hardness have been devised. The most popular ones are called (i) Brinell hardness test, (ii) Rockwell hardness test, and (iii) Vicker's hardness test. All these tests are based on resistance of the material under test against penetration by a specially designed and manufactured "indenter" into the surface of the test specimen under specified load. A harder material offers more resistance and therefore the indenter cannot penetrate its surface to the same depth as it would, if the test specimen were of softer material. Thus the depth of the impression made by the indenter into the test specimen or the area of the impression left by the indenter into the specimen is used to measure the hardness of the material.

It is beyond the scope of this book to give detailed test procedures. However, the essential information is given in Table 1.1.

Table 1.1

	<i>Brinell test</i>	<i>Rockwell test</i>	<i>Vicker's test</i>
Indenter used	Hardened steel ball of 10 mm diameter.	A diamond cone, called brale is used.	A square based diamond pyramid containing an angle of 136° between opposite faces.
Load applied on the indenter during test	3000 kg for 10–15 seconds	Load is applied in two stages. First a minor load of 10 kg followed by major load of 150 kg, in case of 'C' scale.	5 kg–120 kg.
How is hardness number calculated	$\text{BHN} = \frac{\text{Load on ball (kg)}}{\text{Area of ball impression in mm}^2}$	Rockwell hardness No. = 100 – 500 <i>t</i> , where <i>t</i> is depth of indentation.	$\text{VPN or VHN} = \frac{\text{Load}}{\text{Area of impression}}$
Special comment	Depending upon material to be tested, dia of ball and load applied may change	1. There are several hardness scales used like A, B, C etc. They are meant for different materials. The major load applied and even the indenter may change. 2. Hardness is never calculated. The hardness no. is read off a graduated dial. 3. For ferrous material we generally use 'C' scale.	In practice VPN is not calculated. The indentation left by the diamond pyramid is in the shape of a rectangle. The lengths of its diagonals is measured and VPN directly found from a table against the measured value of diagonal.

FRACTURE OF MATERIAL

If a specimen is subjected to high stress beyond its strength, it fails and ultimately fractures in two or more parts. During the description of the tensile test, we have already come across fractures of ductile and brittle material. The ductile fracture occur after considerable plastic deformation and shows a

characteristic reduction in the cross-sectional area near the fractured portion. Brittle fracture occurs suddenly when a small crack in the cross-section of the material grows resulting in a complete fracture. But such fracture does not show much plastic deformation.

Actually, by a careful examination of the fractured surface and the macro and micro metallurgical examination of the fractured specimen, much interesting information as to the probable cause of its failure can be deduced by an experienced metallurgist.

Apart from the ductile and brittle type of fractures, we also have fractures caused by FATIGUE and CREEP of material.

FATIGUE FAILURE

It has been noticed that materials often fail or fracture at a stress level far below their strength, if the stress is either (i) alternating type or (ii) it is varying periodically. What is meant by alternating stress? An example will make this clear. Consider an axle fitted with two wheels. The axle bears the weight of the vehicle and at the same time it rotates along with wheels. Because of weight, the axle under goes a little deflection causing compressive stress in its top half and tensile stress in bottom half of the cross-section. But since it is rotating, with every 180° rotation, the bottom half becomes the top half and vice versa. Thus the nature of stress at any point in the axle keep alternating between compression and tension due to its rotation.

A varying stress cycle means that the magnitude of the stress keeps reducing and increasing periodically although its sign does not change. If the material is subjected to several million cycles of either the alternating or varying stress, it gets fatigued and fails even though the magnitude of such stresses may be far lower as compared to its strength.

Fortunately, there is a level of alternating and varying stress, which the material is able to withstand without failure even if it is subjected to infinite number of cycles. This is called the ENDURANCE LIMIT. A designer ensures that a component subject to fatigue in service is so designed that its actual stress level remains below the endurance limit.

The visual examination of a fatigue fracture shows three distinct zones. These are:

- (i) The point of crack initiation, it is the point from where the crack may have originated *e.g.* a notch like a key way or some materials defect like an impurity, or even a surface blemish.
- (ii) The area of crack propagation during service. This area is usually characterised by circular ring-like scratch marks with point of crack initiation as the centre.
- (iii) Remaining area of cross-section showing signs of sudden breakage. As a result of crack propagation with time, a stage comes, when the remaining cross-sectional area becomes too small to sustain the stress and fractures suddenly.

CREEP FAILURE

Failure of material can take place even under steady loads within the strength of the material. This happens if the subjected components remain under steady loads for a very longtime especially when they are subjected to high temperature conditions. Some common examples are stays in boilers, steam

turbine blades, furnace parts etc. Such failures are termed creep-failures due to the fact the material continues to deform plastically under such conditions although at a very very slow rate. But over long periods of time, the effect of creep can become appreciable resulting in ultimate failure of the component.

QUESTIONS

1. Draw a stress-strain curve for a ductile material. In what respects, a similar curve for a brittle material will be different?
2. What do you understand by the following terms ?
 - (i) Limit of proportionality
 - (ii) Yield-point
 - (iii) Ultimate tensile strength.
3. Explain the meaning of the following terms:
 - (i) Stiffness,
 - (ii) Toughness, and
 - (iii) Hardness.
4. Differentiate between failure of material due to fatigue and creep.
5. What do you understand by percentage elongation? What does a high percentage elongation value signify?
6. Name three common “hardness” tests. Describe anyone of them.

Ferrous Materials

INTRODUCTION

Ferrous material refers to those materials whose main constituent is iron; while non-ferrous materials are those which do not contain iron in any appreciable quantity. Ferrous materials are usually stronger and harder and are used extensively in our daily lives. One very special property of ferrous materials is that, their properties can be significantly altered by heat treatment processes or by addition of small quantities of alloying elements. Ferrous materials are relatively cheap but suffer from a great disadvantage. They are subject to corrosion and rusting.

IRON AND STEEL

Most common engineering materials are ferrous materials such as mild steel and stainless steel which are alloys of iron. It is truly said that gold is metal for kings and iron is king of metals. Otto Von Bismark of Germany once said that “for development of a nation, lectures and meetings are not important, but what is important are blood and steel”. Incidentally, what is common in blood and steel is “iron”. Though iron is important, but it is mostly used in the form of its alloy, namely steel.

To a layman, words iron and steel convey the same meaning. But iron and steel are two different things. Iron is the name given to the metal, whose chemical symbol is Fe and refers to pure (or almost pure iron). Pure iron is relatively soft and less strong. Its melting point is about 1540°C. In industry, wrought iron is the material which is nearest to iron in purity; but is rarely used these days.

Steel, on the other hand, is an alloy of iron and carbon; the percentage of carbon theoretically varies from 0 to 2%. However in actual practice, carbon rarely exceeds 1.25–1.3%. Carbon forms an inter-metallic compound called cementite (Fe_3C), which is very hard, brittle and strong. The presence of cementite in steel makes steel much stronger and harder than pure iron.

CLASSIFICATION OF STEELS

Steel can be classified into (i) plain carbon steel, and (ii) alloy steel. Plain carbon steel is that steel in which the only alloying element present is carbon. In alloy steel, apart from carbon, other alloying

elements like chromium, nickel, tungsten, molybdenum, and vanadium are also present and they make an appreciable difference in the properties of steel.

Before we go further, readers must note that in steels, besides iron and carbon, four other elements are always present. These are S, P, Mn and Si. Removing these elements from steel is not a practical proposition. However, the effect of sulphur and phosphorus on the properties of steel is detrimental and their percentage is generally not allowed to exceed 0.05%. Similarly, the usual percentage of manganese and silicon in steel is kept below 0.8 and 0.3%, although their effect is not detrimental to the properties of steel. In fact, manganese counters the bad effect of sulphur. The presence of these four elements to the extent indicated does not put plain carbon steel into the category of alloy steel. However, if higher percentages of Mn and Si are intentionally added to steel in order to alter its properties, then the resulting steels come within the category of alloy steels.

Plain Carbon Steels

Since the properties of plain carbon steels are so dependent upon their carbon percentage, these steels are further classified into following categories on the basis of carbon percentage only:

- (i) Low carbon or dead mild steel having carbon below 0.15%,
- (ii) Mild steel having carbon between 0.15–0.3%,
- (iii) Medium carbon steel having carbon between 0.3–0.7%, and
- (iv) High carbon steels having carbon content above 0.7% (the higher practical limit of C% is 1.3%).

As the carbon percentage increases, the strength and hardness of plain carbon steel increases while ductility decreases. Reference is invited to Fig. 2.1 (see figure on next page), which shows the effect of increasing carbon percentage on certain mechanical properties of carbon steels.

Applications and Uses of Plain Carbon Steel

Dead mild steel. It has got very good weldability and ductility. Hence, it is used in welded and solid drawn tubes, thin sheets and wire rods, etc. It is also used for those parts which undergo shock loading but must have good wear-resistance. To increase its wear-resistance, the parts have to undergo case hardening process; which provides a hard surface, while the core remains soft and tough.

Mild steel. It is used very extensively for structural work. It retains very good weldability if carbon percentage is limited to 0.25%. Forgings, stampings, sheets and plates, bars, rods and tubes are made of mild steel.

Medium carbon steel. It has little weldability but is stronger and has better wearing property than mild steel. It is used for railway axles, rotors and discs, wire ropes, steel spokes, marine shafts, carbon shafts, general agricultural tools etc.

High carbon steels. It is used for hand tools like cold chisels, cold working dies, hammers, boiler maker's tools, wood working tools, hand taps and reamers, filers, razors, shear blades etc. High carbon steels can be hardened by the process of quenching and being hard can be used for cutting tools which are not used in hot condition. If they become hot (above 150°C), they begin to lose their hardness and become blunt.

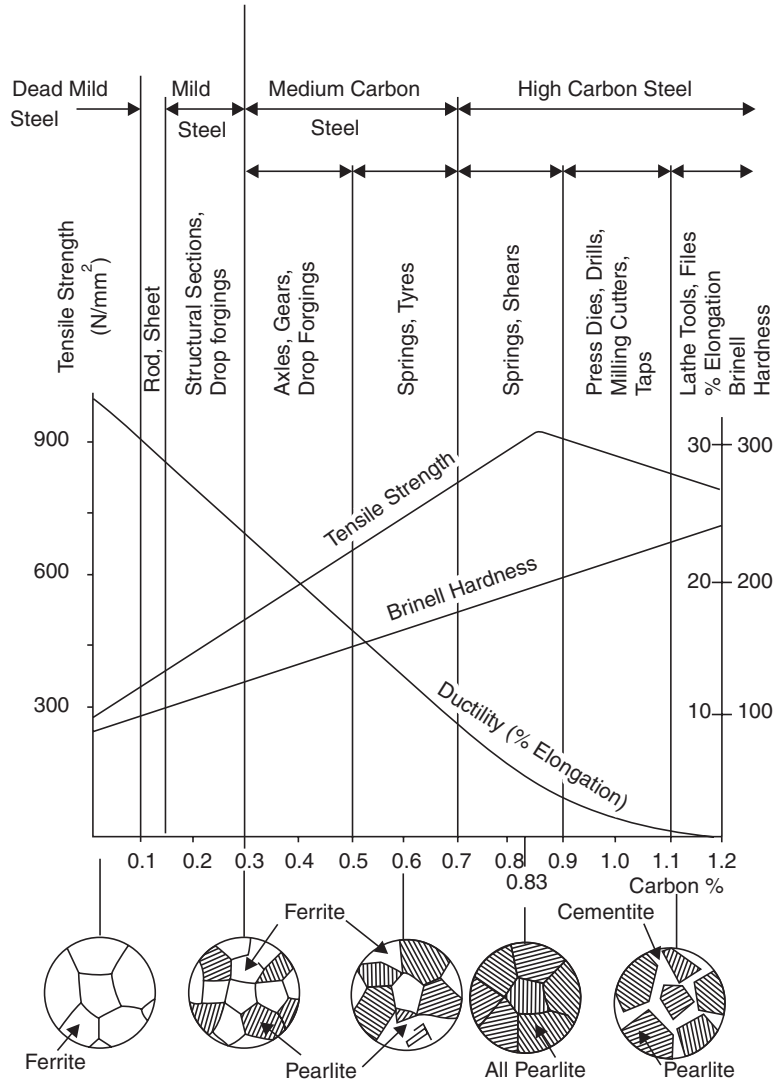

Fig. 2.1 Microstructure, mechanical properties, and uses of plain carbon steels

WROUGHT IRON

It is the purest form of iron; although it may contain traces of carbon. It is usually made by “puddling process” and besides iron contains a small quantity of slag. It is very costly and its use has been almost totally replaced by cheaper steel. However, for some components like chain-links and chain-hooks wrought iron is still the preferred raw material. In old havelis/houses, one can still see iron railings and gates made of wrought iron.

CAST IRON

Cast irons contain more than 2% carbon, which is the theoretical limit for steels. However, in actual practice, carbon content of most cast irons is between 3 to 4 per cent. One characteristic of cast irons (except white cast iron) is that much of the carbon content is present in free form as graphite. It is this fact, which determines, largely, the properties of cast iron.

Cast iron is generally produced in coke-fired cupola furnaces by melting a mixture of pig iron, scrap cast iron and a small percentage (usually not exceeding 5%) of small sized steel scrap. Melting point of cast iron is much lower than that of steel. Most of the castings produced in a cast iron foundry are of grey cast iron. These are cheap and widely used.

There are many varieties of cast iron. These are listed below:

- (i) Grey cast iron,
- (ii) White cast iron,
- (iii) Malleable cast iron,
- (iv) Nodular cast iron, and
- (v) Alloy cast iron.

As already mentioned, Grey cast iron is very widely used in the form of castings. In fact, it is so widely used that the term cast iron has come to mean grey cast iron. If a finger is rubbed on a freshly fractured surface of grey cast iron, the finger will get coated with grey colour due to the graphite present in the cast iron. Grey cast iron has good compressive strength, but is weak in tension. It is relatively soft but brittle. It is very easy to machine and the resulting surface finish is good. It is self lubricating due to presence of graphite and has good vibration damping characteristics. Compared to steel, it resists corrosion.

Due to these properties, it is used extensively for making machine beds, slides, gear-housings, steam engine cylinders, manhole covers, drain pipes etc.

White cast iron and malleable cast iron. White cast iron has 2 to 2.5% carbon and most of it is in the form of cementite. If molten cast iron is cooled very quickly and its chemical composition lacks graphite-promoting elements like Si and Ni, then carbon remains in combined form as Fe_3C . However, white cast iron does not have much use as such. It is very hard and shows white coloured fracture. Only crushing rolls are made of white cast iron. But it is used as raw material for production of malleable cast iron.

Malleable cast iron is manufactured by a complex and prolonged heat treatment of white cast iron castings. Grey cast iron is brittle and has no or very little elongation. Malleable cast iron castings lose some of grey iron's brittleness and become useful even for those applications where some ductility and toughness is required.

(**Note:** "Mottled iron" is a name given to cast iron whose structure shows part grey and part white cast iron characteristics.)

Nodular cast iron. This cast iron is also known under the name of spheroidal graphitic cast iron. If a little bit of magnesium (0.5%) is added to molten cast iron, the graphite, which is normally present in grey iron in the form of graphite flakes, changes its shape to small balls/spheres and remains distributed throughout the mass of cast iron. This change in the shape of graphite particles has a very big

effect on the properties of resulting castings and their mechanical properties improve considerably. The strength increases, yield point improves and brittleness is reduced. Such castings can even replace some steel-components.

Alloy cast iron. The properties of cast iron can be improved by addition of certain alloying elements like nickel, chromium, molybdenum and vanadium, etc. Alloy cast irons have higher strength, heat-resistance and greater wear-resistance etc. Such enhanced properties increase the application and uses of cast irons. I.C. engine cylinders, cylinder liners, piston rings etc. are made of alloy cast irons.

ALLOY STEELS

Just as the properties of cast iron can be improved by adding some alloying elements to its composition, so can the properties of plain carbon steels be improved tremendously by addition of alloying elements. In fact, in the case of steels, the effect of alloying is much more marked. The main object of alloying in steels are:

- (i) Alloy steels can be hardened by heat treatment processes to greater depth and with less distortion and less chance of cracking.
- (ii) Alloying develops corrosion resisting property as in stainless steels.
- (iii) Alloying develops the property of red hardness as in cutting tool.
- (iv) Alloying develops the strength and toughness of steels as in high strength low alloy (HSLA) steels.
- (v) Some alloy steel show a marked resistance to grain growth and oxidation at high temperatures etc.

Main alloying elements used are chromium, nickel, tungsten, molybdenum, vanadium, cobalt, manganese and silicon. Alloy steels are available in a great variety, each one has been developed for a specific purpose. We shall study them by grouping them in (i) stainless steels, (ii) tool steel and (iii) special steels.

Stainless steels. These steels are called stainless because they do not corrode or rust easily. Main alloying elements used are chromium and nickel. Stainless steels are further divided into the following three categories:

(i) **Ferritic stainless steel.** These steels contain a maximum of 0.15% carbon, 6–12% chromium, 0.5% nickel besides iron and usual amounts of manganese and silicon. These steels are stainless and relatively cheap. They are also magnetic. These days, one and two rupee coins are made from such steels. These steel are essentially Iron-chromium alloys and cannot be hardened by heat treatment. Main usage for such steel is in manufacture of dairy equipment, food processing plants, chemical industry etc.

(ii) **Martensitic stainless steel.** These stainless steels have 12–18% chromium but contain higher carbon percentage (0.15–1.2%). These steels can be hardened by heat treatment, but their corrosion resistance is reduced. These steels are used for making surgical knives, hypodermic needles, bolt, nut, screws and blades etc.

(iii) **Austenitic stainless steels.** These are the most important and costliest among all stainless steels. In these steels, besides chromium, nickel is also added. Nickel is a very strong austenite stabiliser and therefore the microstructure of these steels is austenitic at room temperature. The most com-

mon amongst stainless steel is 18/8 steel. Its composition is 18% chromium, 8% nickel, 0.08–0.2% carbon, manganese 1.25% maximum and silicon 0.75% maximum.

Such steels have extremely good corrosion resistance but they cannot be hardened by heat-treatment. However, they are very susceptible to “strain-hardening”. In fact, due to strain hardening, their machining becomes very difficult. It is used extensively for household utensils and in chemical plants and other places where high corrosion resistance is required.

Tool steels. The requirements in a tool steel are that it should be capable of becoming very hard and further, that it should be able to retain its hardness at high temperatures commonly developed during cutting of steel and other materials. This property is called “red hardness”. Further tool steel should not be brittle and should have good strength.

High speed steel (HSS) is the name given to a most common tool steel. Its name implies that it can cut steel at high cutting speeds. At high cutting speed, the temperature rise is higher but high speed steel tools can retain their hardness up to 600–625°C. The property of red hardness comes from addition of tungsten. A typical composition of H.S.S. is tungsten 18%, chromium 4%, vanadium 1%, carbon 0.75–1%, rest iron.

Tungsten is a costly metal. It has been found that molybdenum can also impart “red hardness” to steel and actually half per cent of molybdenum can replace one per cent of tungsten. Molybdenum is far cheaper than tungsten. H.S.S. with tungsten are known as *T*-series and H.S.S. with molybdenum are known as *M*-series steels. A very useful H.S.S. has a composition of tungsten 6%, molybdenum 6%, chromium 4% and vanadium 2%, besides iron and carbon.

Another version of H.S.S. is called super high speed steel. It is meant for heavy duty tools and has about 10–12% cobalt, 20–22% tungsten, 4% chromium, 2% vanadium, 0.8% carbon, rest iron.

These days, tools are made of tungsten carbide and other materials, besides H.S.S.

Special Alloy Steels

(i) **Manganese steels.** All steels contain small amounts of manganese to mitigate the bad effects of sulphur. The true manganese alloy steels contain much larger amounts of Mn. They have work hardening properties. They are used for railway points and crossings, and with usage, they become more wear-resistant.

(ii) **Nickel steels.** Nickel can be added in steels up to 50%. Nickel makes the steel highly resistant to corrosion, non-magnetic, and having very low coefficients of thermal expansion. Such steels are used for turbine blades, internal combustion engine valves etc.

(iii) **Chromium steels.** Chromium makes steel corrosion resistant, and increases its UTS. and IZOD strength. Very often alloy steels are used with both chromium and nickel being added. Ni-Cr steel wires are often used in furnaces, toasters and heaters.

(iv) **Silicon steels.** A steel containing 0.05% carbon, about 0.3% Mn and 3.4% of silicon possesses extremely low magnetic hysteresis and is used widely for making laminations of electrical machines. Silico-manganese steels are also used frequently for making springs.

HEAT TREATMENT OF CARBON STEELS

Object of heat treatment. Metals and alloys are heat treated to improve their mechanical properties, to relieve internal stresses or to improve their machinability. The properties of carbon steels can also be altered significantly by subjecting them to heat treatment processes.

Heat treatment consists of three basic steps:

- (i) Heat the metal/alloy to a predetermined temperature. This temperature will, ideally, depend upon the actual composition of carbon steel (*i.e.* carbon percentage),
- (ii) Soaking or holding the metal/alloy at that temperature for some time, so that the temperature across the entire cross-section becomes uniform, and
- (iii) Cooling the metal/alloy at a predetermined rate in a suitable medium like water, oil or air.

The rate of cooling is the most important factor.

Kinds of Heat Treatments Given to Carbon Steels

Carbon steels are subjected to the following four basic heat-treatment processes:

- (i) Annealing,
- (ii) Normalising,
- (iii) Hardening, and
- (iv) Tempering.

We shall now describe these processes very briefly.

Annealing. The purpose of annealing is to soften the material. Along with softening, the internal stresses, if any, will also get removed.

The approximate temperatures to which the steel-sample should be heated will depend upon its carbon content. The recommended temperatures are shown in the following table:

Table 2.1

<i>Material</i>	<i>Annealing temp. (°C)</i>
Dead mild steel (Carbon < 0.15%)	870–930
Mild steel (Carbon 0.15–0.3%)	840–870
Medium carbon steel (Carbon 0.3–0.7%)	780–840
High carbon steel (Carbon 0.7–1.5%)	760–780

Soaking time may be given at the rate of 3-4 minutes for every one mm thickness of the cross-section of material.

In annealing, the work piece is allowed to cool inside the furnace only after switching off electrical power or oil supply to the furnace. This ensures that the work piece cools at a very slow rate. This process results in softening of material and increase in ductility due to grain growth.

Normalising. Normalising entails heating to the same temperatures as recommended for annealing (except for high carbon steel specimens, which are to be heated to much higher temperatures than for annealing particularly as carbon percentage in sample increases), soaking and then cooling the sample in still air. Main object of normalising is getting rid of internal stresses and grain-refinement.

Hardening. Hardening involves heating (to the same temperatures as in case of annealing) and soaking. Thereafter, the work piece is taken out of the furnace and quickly cooled at a very fast rate in a tank of cold water or oil, agitating the water/oil vigorously. (This cooling operation is called “quenching.”) The result is hardening of the work piece. However, in order to harden, the carbon content in the work piece should be at least 0.25%. Therefore, dead mild steel cannot be hardened in this way. Mild steel will also harden slightly for specimens containing over 0.25% carbon. Higher the carbon percentage, higher will be resulting hardness.

Hardened pieces become brittle and their extreme brittleness becomes a great disadvantage. They tend to fail in-service. Therefore hardening process is invariably followed by a tempering process.

Tempering. Tempering means giving up a certain amount of hardness but shedding a great deal of brittleness acquired in the process of hardening. It is a trade off between hardness and brittleness, so that hardened component may give useful service without failure.

Tempering involves heating the carbon steel part to a temperature varying from 150°–600°C (depending upon how much trade off is required) and cooling the component in an oil or salt bath or even in air.

Case hardening. As mentioned above, only those carbon steels can be hardened whose carbon content is about 0.25% or more. How do we harden dead mild steel? The answer is by case hardening. In this process, the work piece is packed in charcoal and heated as in annealing. It is kept at that high temperature for a few hours. The result is that carbon enters into the surface of the work piece to the depth of a mm or two depending upon the heating time.

The work piece now has a case where carbon percentage is as per requirement for hardening. It is then heated and quenched in the usual manner. The result is a component whose surface acquires hardness, but core remains soft and tough.

QUESTIONS

1. What is the importance of ferrous materials in our daily lives?
2. What is steel? How is it different from iron? Differentiate between plain carbon steels and alloy steels.
3. What are the characteristic properties of cast iron?
4. Describe the object of annealing. How is it different from “normalising”?
5. Describe the process of hardening steel. Why are hardened objects subjected to tempering treatment after hardening them?
6. Write a brief note about stainless steels. What constituent of such steels render them corrosion-resistant.
7. What are different types of cast irons?
8. What is the object of alloying steels?

Non-Ferrous Metals and Alloys

INTRODUCTION

Non-ferrous metals and alloys do not contain any significant quantity of iron. The most common non-ferrous metals used in engineering applications are copper, aluminium, tin, lead and zinc. Nickel, magnesium and antimony are also used for alloying the aforesaid non-ferrous metals.

PROPERTIES AND USES OF NON-FERROUS METALS

Copper. Copper is a corrosion resistant metal of an attractive reddish brown colour. It is an extremely good conductor of heat and electricity. It can also be drawn in wires, beaten into sheets and plates. Hence, it is extensively used in electrical industry for making armature coils, field coils, current carrying wires, household utensils etc. But its great usefulness lies in the fact that it alloys with zinc, tin and nickel to yield brass, bronze and cupro-nickels respectively which are widely used in engineering industry. Copper, as such, is used for many decorative items.

Not much of copper is available in India. We import at least 50–60% of our requirement every year.

Aluminium. Aluminium metal is difficult to extract from its main ore called bauxite. However, bauxite is available in India very plentifully and we have a thriving aluminium industry. Aluminium is also very corrosion resistant (because an adherent oxide layer protects it from further oxidation). It is again a very good conductor of heat and electricity (although not as good as Cu). It is ductile and malleable and is much cheaper than copper. Hence, it has all but replaced copper wires for transmission of electricity. It is also used for household utensils including pressure cookers. However, since it can be converted into thin foils, it is now extensively used for beverage cans and in packaging industry. Its density is about a third of steel, hence it is also used for aircraft and helicopter frames and in transport vehicles.

Sometime ago, in India, 1, 2, 5, 10 and 20 paise coins were made of an aluminium-magnesium alloy. Aluminium forms a series of alloys with magnesium, which are harder and stronger than pure aluminium.

Tin. It has an attractive silvery white colour. It has very good resistance to acid corrosion. Before the advent of plastic tin coated steel sheets of thin gauge were used for manufacture of

tin-containers for storage of ghee, mustard and other oils. Today tin is mostly used for alloying purposes. Tin and lead melted together give a series of soft-solders. Tin has a low melting point.

Lead. Lead is a heavy metal with dull grey appearance. It has good corrosion resistance and has got good malleability. In Europe, it was extensively used for roof protection. It was also used in plumbing. It can withstand sulphuric acid and previously this acid used to be stored in lead lined vessels. It has self lubricating properties. It was therefore used in lead-pencils.

Sometimes, a small quantity of lead is added to steel and tin bronze to impart free cutting properties.

Zinc. Zinc possesses a bluish grey metallic appearance. It has high corrosion resistance. In fact, steel sheets are often covered by a thin coating of zinc. Such zinc coated sheet are known as galvanised iron sheets (G.I. sheets). The zinc coating provides protection to steel sheets from corrosion for many years.

Zinc has a low melting point and high fluidity making it suitable for items to be produced by die-casting process. Zinc is incidentally much cheaper than either copper or tin; making brass, an alloy of copper and zinc much cheaper than copper or tin-bronze. Zinc is also used in torch light batteries.

In the following table, colour, tensile strength, melting point–specific gravity and important properties of some non-ferrous metals are given.

Table 3.1

<i>Metal</i>	<i>Tensile strength N/mm²</i>	<i>Colour</i>	<i>Specific Gravity</i>	<i>M.P. (°C)</i>	<i>Few important properties</i>
Copper	160	Reddish brown	8.9	1083	Good conductor, soft, ductile and malleable
Aluminium	60	White	2.7	660	Good conductor, very soft, ductile and malleable
Tin	13	Silvery white	7.3	232	Good appearance, acid resistance, soft
Lead	15	Dull grey	11.4	327	Very heavy, good corrosion resistance against H ₂ SO ₄
Zinc	155	Bluish, white	7.1	419	Good corrosion resistance and fluidity when molten

Note: For comparison, tensile strength of Iron is 270 N/mm².

ALLOYS OF COPPER

Brass

Brass is an alloy of copper and zinc. Commercially, two types of brasses are most important:

1. **Alpha brass.** It contains up to 36% zinc and remainder is copper.
2. **Alpha-Beta brass.** It contains from 36% to 46% Zn, remainder is copper.

Alpha and Beta are names given to different phases of brasses. Alpha-Beta brass contain both alpha and beta phases.

The tensile strength and ductility of brass both increase with increasing Zn content up to 30% zinc. If zinc content increases beyond 30%, the tensile strength continues to increase up to 45% Zn, but

there is a marked drop in ductility of brasses. β -phase is much harder and stronger but less ductile than α -phase. α -phase has excellent cold-formability and is used where the parts are wrought to shape. The mechanical properties of α -brasses also change with the amount of cold-work done on them. α - β brasses are fit for hot working.

α -brasses can be sub-divided into two groups—

(i) red-brasses containing up to 20% Zn, and

(ii) yellow brasses containing over 20% Zn.

Red brasses are more expensive and are primarily used where their colour, greater corrosion resistance or workability are distinct advantages. They have good casting and machining properties and are also weldable. One well-known red-brass is “gilding-brass” or gilding metal with 5% Zn. It is used for decorative work. Yellow brasses are most ductile and are used for jobs requiring most severe cold forging operations. The cartridges are made from a 70% Cu, 30% Zn brass by a deep drawing process, hence this composition of yellow brass has come to be known as cartridge brass.

Other famous compositions of brasses are:

Admirability brass containing 29% Zn, 1% Tin, remaining copper.

Muntz’ metal contains 40–45% Zn, remainder is copper.

Naval Brass contains 39% Zn, 1% Tin, remainder is copper.

Admiralty brass, naval brass and muntz metal are all used for ships-fittings, condenser tubes, preheaters, heat exchangers etc.

Bronzes

Bronze is an alloy of copper and tin although commercial bronzes may contain other elements besides tin. In fact, alloys of copper with aluminium, silicon and beryllium, which may contain no tin are also known as bronzes.

Tin bronzes are of a beautiful golden colour. As in brasses, both tensile strength and ductility of bronzes increase with increases in tin content. However, more than 10% tin is not used in bronze as it results in the formation of a brittle intermetallic compound, Cu_3Sn . Addition of tin to copper up to 10% increases the strength, hardness and durability to a much greater extent than the addition of zinc to copper.

The following varieties of tin bronzes are commonly used:

- (i) **Phosphor-Bronze.** Addition of 0.5% phosphorous to tin bronze results in production of phosphorous bronze. Phosphorous increases fluidity of molten metal and fine castings can be made.
- (ii) **Leaded-Bronze.** Addition of lead to tin bronze, results in production of leaded bronze. Lead is actually a source of weakness, but adds to machinability and has self lubricating properties. Usually, lead percentage does not exceed 2%.
- (iii) **Gun-metal.** It contains 2% zinc, 10% tin and 88% copper. It is a very famous composition. This bronze is used for bearing bushes, glands, pumps, valves etc.
- (iv) **Bell-metal.** It is a tin bronze but having a very high percentage of tin (20–25%). It gives a good tinkling sound on being struck with a hammer.

Bronzes having no tin. The following bronzes contain no tin and are commercially well-known:

- (i) **Aluminium bronze.** Composition: 14% Aluminium, rest copper. It possesses good strength and good corrosion resistance. Colour: golden yellow. Often used for costume jewellery.
- (ii) **Silicon bronze.** Composition: 1–4% Silicon, rest mainly copper. Possesses extremely good corrosion resistance. Can be cold worked and strain-hardened. Used for boiler fitting and marine fittings.
- (iii) **Manganese bronze.** Composition: 40% zinc and 55–60% copper with 3–5% manganese. It is essentially a brass to which manganese has been added. It is used for ship's propellers.
- (iv) **Beryllium bronze.** Beryllium is very costly. So is this alloy. It contains about 2% Be. It has very good mechanical properties and can be cold worked and age-hardened. It is mainly used for bellows, bourdon gauge tubes etc.

CUPRO-NICKELS

Cupro-nickels are alloys of copper and nickel. Copper and nickel, when melted together in any proportion are perfectly miscible and dissolve each other. When the alloy solidifies, the solubility continues forming a solid solution.

Cupro-nickels are silvery white in colour and have extremely good corrosion-resistance. They are extensively used for marine fittings. They also possess good strength, hardness and ductility. Coins of rupee five are made of 75% copper and 25% nickel. However, another alloy containing 45% Ni and 55% copper is called “constantan”. It is used for manufacture of thermocouples, low temperature heaters and resistors.

ALUMINIUM ALLOYS

Aluminium as such is a soft metal of relatively low strength. Most of the alloys of aluminium are made by alloying it with various percentages of magnesium; these are harder and stronger. These alloys known as L-M series alloys can be extruded and are used extensively for structural work.

A famous alloy of Aluminium containing 4% copper, 0.5% magnesium, 0.5% manganese, a trace of iron and rest aluminium is called DURALUMIN. It has high strength and a low specific gravity. However, its corrosion resistance is much lower as compared to pure aluminium. Sometimes, duralumin is covered or clad by thin aluminium layer on all sides. Such material is called ALCLAD and is used in aircraft industry.

If 5–15% silicon is alloyed with aluminium, we get alloys which are temperature resistant. Castings made of Al-Si alloys are used for manufacture of pistons of two wheelers on a large scale.

ALLOYS OF NICKEL

(i) **German silver.** It is a cupro nickel to which zinc has been added. A typical composition is 60% copper, 30% nickel and 10% zinc. Addition of zinc brings down the cost. Its colour is silvery with a slight pale tinge. It is very ductile and malleable and corrosion resistant. It is used for making electrical contacts, costume jewellery and high quality taps etc. Before the advent of stainless steel, it was also used for household utensils and coinage.

(ii) **Monel metal.** Its composition is 68% nickel, 30% copper, 1% iron, remainder manganese etc.

(iii) **Nichrome.** Alloy of nickel and chromium, which is used as heat resistant electrical wire in furnaces, and electrical heating devices like geysers, electric iron etc.

(iv) **Inconel and incoloy.** Alloys principally containing, nickel, chromium and iron. Used in electrical industry.

QUESTIONS

1. Differentiate between ferrous and non-ferrous materials.
2. What are characteristic properties of copper and aluminium, which make them useful to mankind?
3. Differentiate between bronzes and brasses. Mention two applications of each.
4. Write a short note on aluminium and its alloys.
5. What are the different types of brasses you know? Distinguish between Naval and Admiralty brass.
6. What are cupro nickel? What are their main properties and applications?

Objective Type Questions

Pick out the most appropriate option:

1. Mild steel is an alloy of iron and carbon with percentage of carbon ranging from
(a) up to 0.2% (b) 0.15–0.3
(c) 0.3–0.5 (d) above 0.5.
2. IZOD test measures
(a) hardness (b) ductility
(c) impact-strength (d) grain size.
3. Copper is used for making electrical conductors because it is
(a) ductile (b) resists corrosion
(c) has low resistance (d) cheap.
4. Brass is an alloy of
(a) copper and zinc (b) tin and zinc
(c) copper and tin (d) copper and Al.
5. A small amount of phosphorous is present in
(a) all bronzes (b) phosphor-bronze
(c) tin bronze (d) beryllium bronze.
6. Which test measures hardness?
(a) Brinell test (b) Rockwell test
(c) Vicker's test (d) All of these tests.
7. The object of 'normalising' a steel specimen is
(a) to reduce hardness (b) to relieve stresses
(c) to refine structure (d) to improve ductility.
8. The melting point of steel increases with
(a) reduced carbon content (b) increased carbon content
(c) none of these.

9. The strength of steel increases with increasing carbon %age in the range
(a) 0–0.8% (b) 0.8–1.2%
(c) 1.2–2% (d) all of these ranges.
10. Aluminium alloys find use in aircraft industry because of
(a) high strength (b) low sp. gravity
(c) good corrosion resistance (d) good weldability.

Indicate, if following statements are True or False:

11. It is possible to ascertain the value of Young's modulus of elasticity from the results of a tensile test.
12. Toughness depends upon the ductility of a material.
13. Higher the value of modulus of elasticity for a material, higher is its stiffness.
14. The hardness in steel is basically due to presence of cementite.
15. The tensile strength of cast iron is as good as that of mild steel.
16. Nickel-silvers are alloys of Nickel and silver.
17. The red-hardness in high speed steel is due to addition of chromium in such steels.
18. Many stainless steels cannot be hardened by heat treatment process.
19. Tempering is the reverse of hardening.
20. Aluminium bronze contains copper, tin and aluminium.

ANSWERS

- | | | | | |
|--------|--------|--------|--------|---------|
| 1. (b) | 2. (c) | 3. (c) | 4. (a) | 5. (a) |
| 6. (d) | 7. (c) | 8. (a) | 9. (a) | 10. (b) |
| 11. T | 12. T | 13. T | 14. T | 15. F |
| 16. F | 17. F | 18. T | 19. T | 20. F |

**This page
intentionally left
blank**

UNIT II

Introduction to Metal Forming and Casting Process

**This page
intentionally left
blank**

Basic Metal Forming Processes and Uses

INTRODUCTION

Metal forming processes, also known as mechanical working processes, are primary shaping processes in which a mass of metal or alloy is subjected to mechanical forces. Under the action of such forces, the shape and size of metal piece undergo a change. By mechanical working processes, the given shape and size of a machine part can be achieved with great economy in material and time.

Metal forming is possible in case of such metals or alloys which are sufficiently malleable and ductile. Mechanical working requires that the material may undergo “plastic deformation” during its processing. Frequently, work piece material is not sufficiently malleable or ductile at ordinary room temperature, but may become so when heated. Thus we have both hot and cold metal forming operations.

Many metal forming processes are suitable for processing large quantities (*i.e.*, bulk) of material, and their suitability depends not only upon the shape and size control of the product but also upon the surface finish produced. There are many different metal forming processes and some processes yield a better geometry (*i.e.*, shape and size) and surface-finish than some others. But, they are not comparable to what can be achieved by machining processes. Also cold working metal forming processes result in better shape, size and surface finish as compared to hot working processes. Hot working results in oxidation and decarburisation of the surface, formation of scales and lack of size control due to contraction of the work piece while it cools to room temperature.

ADVANTAGES OF MECHANICAL WORKING PROCESSES

Apart from higher productivity, mechanical working processes have certain other advantages over other manufacturing processes. These are enumerated below:

1. Mechanical working improves the mechanical properties of material like ultimate tensile strength, wear resistance, hardness and yield point while it lowers ductility. This phenomenon is called “strain hardening”.

2. It results in grain flow lines being developed in the part being mechanically worked. The grainflow improves the strength against fracture when the part is in actual use. This is best explained by taking illustration of a crankshaft. If the crankshaft is manufactured by machining from a bar of large

cross-section, the grain flow lines get cut at bends whereas in a crankshaft which is shaped by forging (which is a mechanical working process), the grain flow lines follow the full contour of the crankshaft making it stronger. This is illustrated in Fig. 1.1.

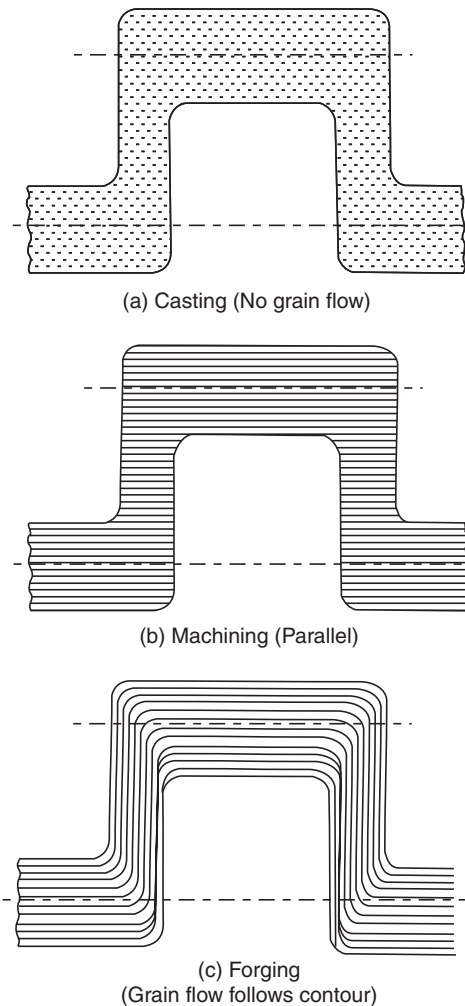

Fig. 1.1 Comparison of grain flow

During mechanical working, the grains of the metal get deformed and lengthen in the direction of metal flow. Hence they offer more resistance to fracture across them. Hence mechanically worked components have better mechanical strength in a certain orientation *i.e.*, across the grain flow.

DIFFERENCE BETWEEN HOT AND COLD WORKING

Cold working (or cold forming, as it is sometimes called) may be defined as plastic deformation of metals and alloys at a temperature below the recrystallisation temperature for that metal or alloy. When this happens, then the strain hardening which occurs as a result of mechanical working, does not get

relieved. Infact as the metal or alloys gets progressively strain hardened, more and more force is required to cause further plastic deformation. After sometime, if the effect of strain hardening is not removed, the forces applied to cause plastic deformation may infact cause cracking and failure of material.

Hot working may be explained as plastic deformation of metals and alloys at such a temperature at which recovery and recrystallisation take place simultaneously with the strain hardening. Such a temperature is above recrystallisation temperature. Properly done hot working will leave the metal or alloy in a fine grained recrystallised structure.

A word about recrystallisation temperature will not be out of place here. Recrystallisation temperature is not a fixed temperature but is actually a temperature range. Its value depends upon several factors. Some of the important factors are:

(i) **Nature of metal or alloy:** It is usually lower for pure metals and higher for alloys. For pure metals, recrystallisation temperature is roughly one third of its melting point and for alloys about half of the melting temperature.

(ii) **Amount of cold work already done:** The recrystallisation temperature is lowered as the amount of strain-hardening done on the work piece increases.

(iii) **Strain-rate:** Higher the rate of strain hardening, lower is the recrystallisation temperature.

For mild steel, recrystallisation temperature range may be taken as 550–650°C. Recrystallisation temperature of low melting point metals like lead, zinc and tin, may be taken as room temperature. The effects of strain hardening can be removed by annealing above the recrystallisation temperature.

ADVANTAGES AND DISADVANTAGES OF COLD AND HOT WORKING PROCESSES

(i) Since cold working is practically done at room temperature, no oxidation or tarnishing of surface takes place. No scale formation is there, hence there is no material loss. In hot working opposite is true. Besides, hot working of steel also results in partial decarburisation of the work piece surface as carbon gets oxidised as CO_2 .

(ii) Cold working results in better dimensional accuracy and a bright surface. Cold rolled steel bars are therefore called bright bars, while those produced by hot rolling process are called black bars (they appear greyish black due to oxidation of surface).

(iii) In cold working heavy work hardening occurs which improves the strength and hardness of bars, but it also means that high forces are required for deformation increasing energy consumption. In hot working this is not so.

(iv) Due to limited ductility at room temperature, production of complex shapes is not possible by cold working processes.

(v) Severe internal stresses are induced in the metal during cold working. If these stresses are not relieved, the component manufactured may fail prematurely in service. In hot working, there are no residual internal stresses and the mechanically worked structure is better than that produced by cold working.

(vi) The strength of materials reduces at high temperature. Its malleability and ductility improve at high temperatures. Hence low capacity equipment is required for hot working processes. The forces on the working tools also reduce in case of hot working processes.

(vii) Sometimes, blow holes and internal porosities are removed by welding action at high temperatures during hot working.

(viii) Non-metallic inclusions within the work piece are broken up. Metallic and non-metallic segregations are also reduced or eliminated in hot working as diffusion is promoted at high temperatures making the composition across the entire cross-section more uniform.

Typical Hot Working Temperatures

Steels	650–1050°C
Copper and alloys	600–950°C
Aluminium and alloys	350–485°C

CLASSIFICATION OF METAL FORMING PROCESSES ACCORDING TO TYPE OF STRESS EMPLOYED

Primary metal working processes are those in which the bulk material in the form of ingots, blooms and billets is broken down to required shapes and sizes by processes such as forging, rolling, extrusion etc. These processes can be categorised on the basis of the kind of stress employed in the material, that is:

- (i) Mainly compression type, (Examples: forging, rolling, extrusion etc.).
- (ii) Mainly tension type (Example: drawing).
- (iii) Combined compression and tension type, (Examples : deep drawing, embossing etc.).

Many of these processes are shown schematically in Fig. 1.2.

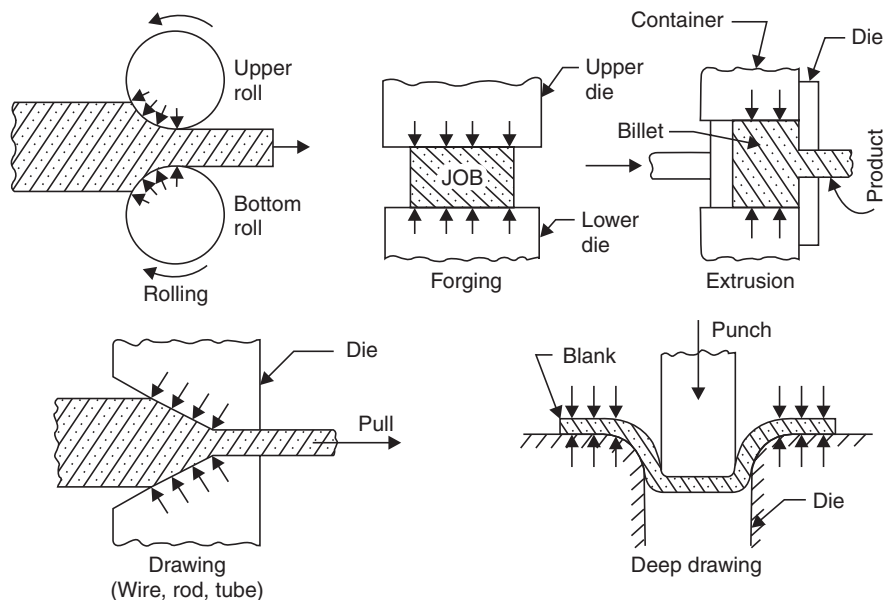

Fig. 1.2 Typical metal working processes

QUESTIONS

1. Explain the meaning of the expression 'metal forming'. Mention the names of five metal forming processes.
2. What is the difference between hot forming and cold forming ?
3. What is the significance of "recrystallisation" temperature in metal forming ?
4. What do you understand by "grain flow" ? How is it connected with the strength of machine parts ?

Forging

INTRODUCTION

In forging, metal and alloys are deformed to the specified shapes by application of repeated blows from a hammer. It is usually done hot; although sometimes cold forging is also done. The raw material is usually a piece of a round or square cross-section slightly larger in volume than the volume of the finished component. Depending on the end use of the component, the forged part may be used as such or (more frequently) it has to be machined to correct size to close tolerances. The initial volume of material taken must, therefore, allow for loss due to scaling and the machining allowance.

CLASSIFICATION OF FORGING

Forging is done by hand or with the help of power hammers. Sometimes hydraulic presses are also used for forging.

(a) **Hand Forging:** Under the action of the compressive forces due to hammer blows, the material spreads laterally *i.e.*, in a direction at right angles to the direction of hammer blows. Obviously brittle material like cast iron cannot be forged as it will develop cracks under the blows from hammer. An ordinary blacksmith uses an open-hearth using coke (or sometimes steam coal) as fuel for heating the metal and when it has become red-hot, blacksmith's assistant (called striker or hammerman) uses a hand held hammer to deliver blows on the metal piece while the blacksmith holds it on an anvil and manipulates the metal piece with a pair of tongs. This type of forging is called "hand forging" and is suitable only for small forgings and small quantity production.

A blacksmith's hearth, ancillary equipment and tools used by the blacksmith are shown in Fig. 2.1.

Basic forging operations employed in giving required shape to the work piece are described below:

(i) **Upsetting:** It is the process of increasing the cross-section at expense of the length of the work piece.

(ii) **Drawing down:** It is the reverse of upsetting process. In this process length is increased and the cross-sectional area is reduced.

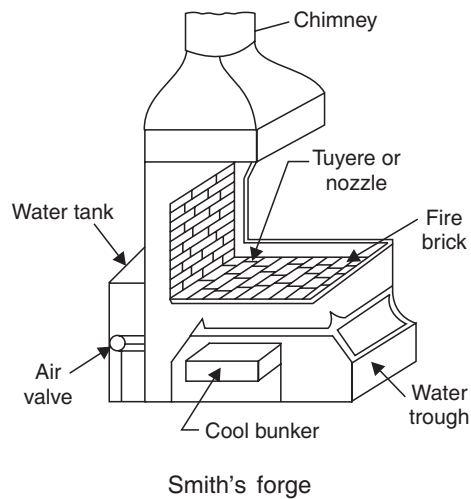
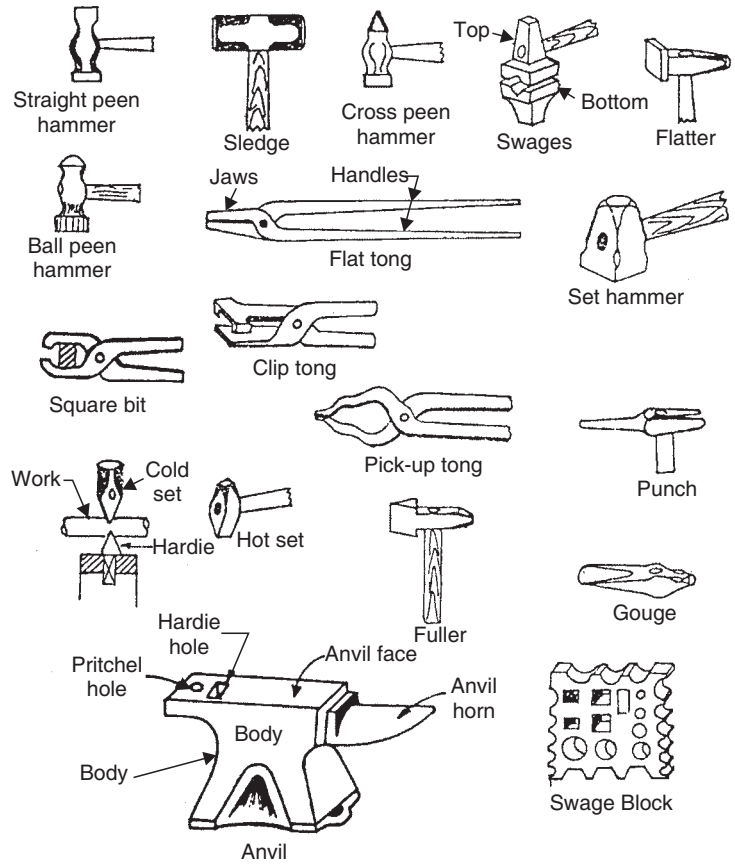

Fig. 2.1 Tools used in smithy and smith's forge

(iii) **Cutting:** This operation is done by means of hot chisels and consists of removing extra, metal from the job before finishing it.

(iv) **Bending:** Bending of bars, flats and other such material is often done by a blacksmith. For making a bend, first the portion at the bend location is heated and jumped (upset) on the outward surface. This provides extra material so that after bending, the cross-section at the bend does not reduce due to elongation.

(v) **Punching and drifting:** Punching means an operation in which a punch is forced through the work piece to produce a rough hole. The job is heated, kept on the anvil and a punch of suitable size is forced to about half the depth of the job by hammering. The job is then turned upside down and punch is forced in from the otherside, this time through and through.

Punching is usually followed by drifting *i.e.*, forcing a drift in the punched hole through and through. This produces a better hole as regards its size and finish.

(vi) **Setting down and finishing:** Setting down is the operation by which the rounding of a corner is removed to make it a square. It is done with the help of a set hammer. Finishing is the operation where the uneven surface of the forging is smoothed out with the use of a flatter or set hammer and round stems are finished to size with the use of swages after the job has been roughly brought to desired shape and size.

(vii) **Forge welding:** Sometimes, it may become necessary to join two pieces of metal. Forge welding of steel is quite common and consists of heating the two ends to be joined to white heat ($1050^{\circ}\text{C} - 1150^{\circ}\text{C}$). Then the two ends of steel are brought together having previously been given a slight convex shape to the surfaces under joining. The surfaces are cleaned of scale. They are then hammered together using borax as flux. The hammering is started from centre of the convex surface and it progresses to the ends. This results in the slag being squeezed out of the joint.

Hammering is continued till a sound joint is produced. Several types of joints can be made *viz.*, butt joint, scarf joint or splice joint.

Various forging operations described above and forge welding joints are shown in Figs. 2.2 and 2.3.

(b) **Forging with Power Hammers:** The use of hand forging is restricted to small forgings only. When a large forging is required, comparatively light blows from a hand hammer or a sledge hammer wielded by the striker will not be sufficient to cause significant plastic flow of the material. It is therefore necessary to use more powerful hammers. Various kinds of power hammers powered by electricity, steam and compressed air (*i.e.*, pneumatic) have been used for forging. A brief description of these hammers is now given.

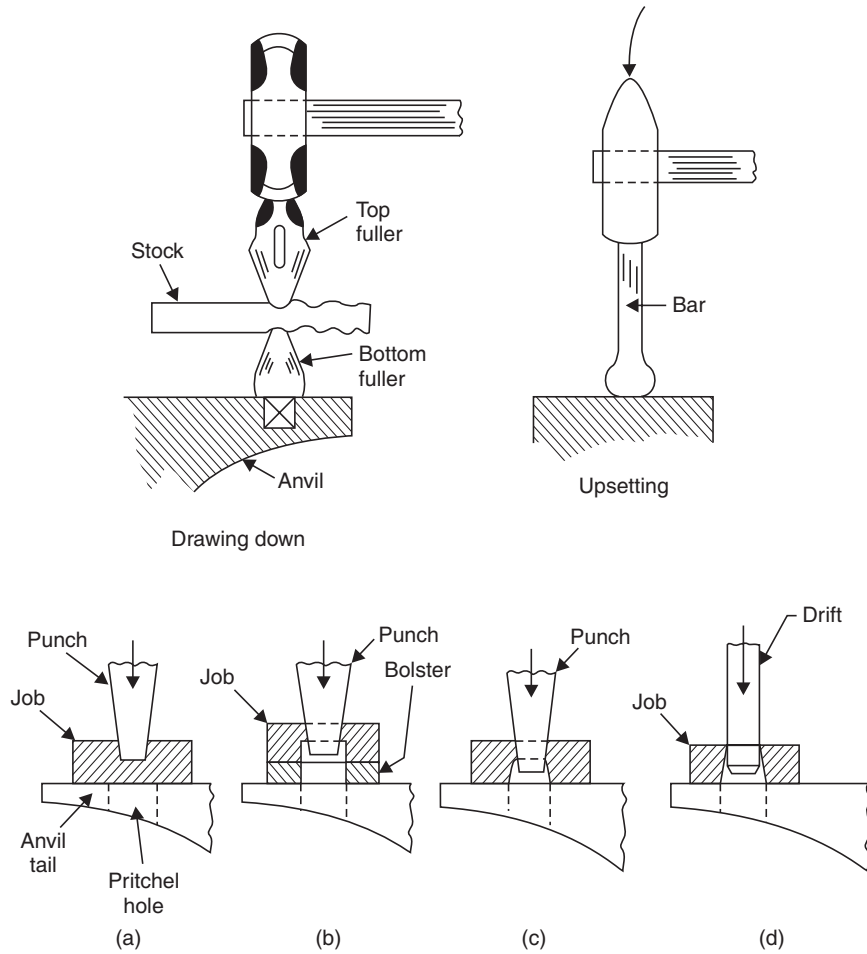

(a) Job placed on anvil and punched half-way on one side (b) Job turned upside down, being punched through using a bolster (c) Job turned upside down, being punched through using Pritchel hole (d) Operation of drifting

Fig. 2.2 Some common hand forging operations

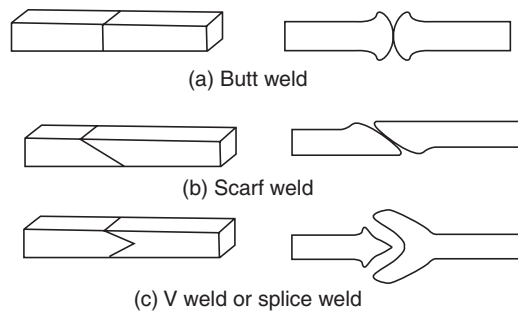

Fig. 2.3 Welded joints and end preparations

(i) **Spring hammer:** It is a light hammer powered by an electric motor and gives repeated blows when it is operated by a foot operated treadle. This type of hammer is now obsolete and was best suited for small forgings. Though various designs of this hammer were in use, a typical spring hammer is shown in Fig. 2.4.

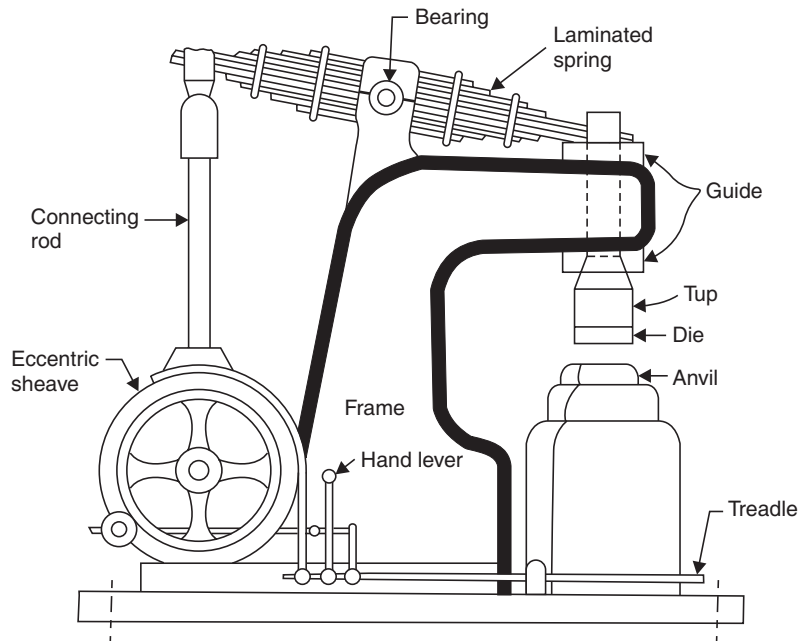

Fig. 2.4 A spring hammer

In this design, an electric motor rotates a pair of pulleys, a loose and another fast pulley. The loose pulley rotates idly on its shaft. The fast pulley is fastened on its shaft by means of a key, so that when fast pulley rotates, it rotates the shaft as well. The shaft carries an eccentric sheave on it with the result that when the electric motor rotates the fast pulley, the eccentric sheave also rotates with it and imparts vertical reciprocatory motion to the connecting rod. This upper end of the connecting rod is connected to one end of a laminated bearing spring. The other end of this spring is connected to a ram which can slide up and down in a vertical guide provided in the machine frame at the front of the machine. To this ram, a tup (and a die, if required) is fitted. Also resting vertically below the ram and tup is an anvil resting on a base. The electric motor is normally connected to the loose pulley, but when the hammer operator depresses the treadle with his foot, the motor gets connected to the fast pulley and when the connecting rod moves up, the front end of the spring moves down, the spring buckle in the centre of the spring being pivoted. When the connecting rod moves down, the ram moves up. Thus rotation of motor causes up and down motion of ram and tup which is used for hammering the work piece kept on the anvil.

Usually there is an arrangement for shifting the position of the pivot. If the pivot is shifted towards the connecting rod, the vertical movement of ram and tup increases and so does the severity of the hammering action. When the pressure of foot is removed from the treadle, the motor gets connected

to the loose pulley and a brake applies automatically stopping the hammering action instantly. Spring hammers were made in various capacities with tups weighing from 30 to 250 kg and having a capability of running up to 300 blows per minute.

(ii) **Pneumatic power hammers:** A typical form of pneumatic hammer is shown in Fig. 2.5.

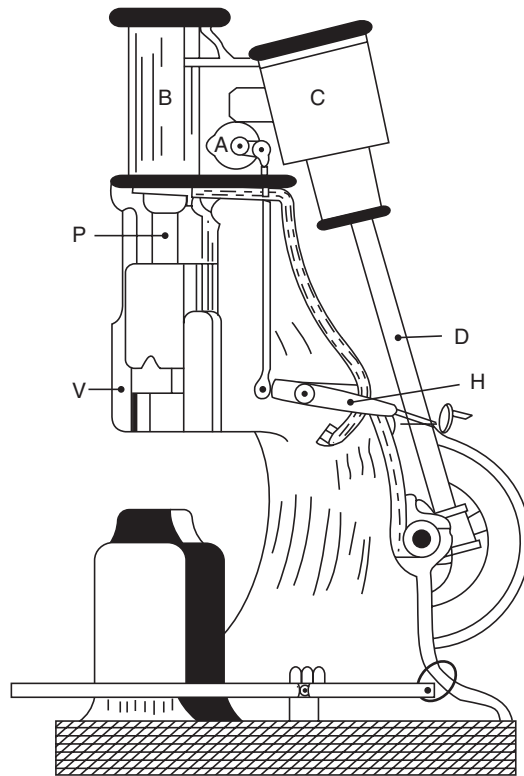

Fig. 2.5 Pneumatic power hammer

An electric motor rotates a crank which in turn moves a connecting rod (*D*) to and fro *i.e.*, the rotary motion of the crank is converted into a reciprocating motion. This reciprocating motion is delivered to a piston working inside cylinder '*C*'. The cylinder and piston assembly is provided with suitable air inlet ports, so that the entire assembly acts as a reciprocating air compressor. The compressed air can be delivered to another cylinder piston assembly *B*, through the air-valve *A*. This air valve *A* is operated by the hammerman or the person operating the hammer by means of the handle shown *H* in the figure.

When the air valve *A* is fully closed, it disconnects the supply of air to cylinder *B* and the piston of cylinder *B* rests in the bottom position. At this juncture the tup attached to the piston through a piston rod (*P*) rests on the anvil. However when the air valve '*A*' is opened, the air compressed in cylinder *C* is delivered to cylinder *B*, which is a double acting cylinder. The compressed air first enters below the piston lifting the piston up and then it enters above the piston forcing it downwards with great force. This upward and downward motion of the piston in cylinder *B* is delivered to the tup which moves in a vertical guide *V* provided in the frame of the power hammer and the tup strikes on the work piece kept on the anvil below it.

By regulating the opening of air valve *A*, the severity of the blows can be controlled from very light to very heavy. The capacity of the hammer is characterised by the weight of moving parts including the tup in cylinder *B*. Pneumatic hammers are available in capacities varying from quarter of a ton to five tonnes.

(iii) **Steam hammers:** These hammers differ from the pneumatic hammer described above in that for raising steam, a separate boiler is required. Thus in a steam hammer, cylinder '*C*' of the pneumatic hammer is not required. The piston in cylinder *B* is powered by the steam drawn from the boiler and operated by a simple slide valve mechanism. The cylinder *B* is double acting and since the steam pressure is higher than the air pressure in pneumatic hammers, the striking force in steam hammers is higher than for similar size of pneumatic hammer.

DIE FORGING WITH POWER HAMMERS

The tools used for power hammers are similar in shape to the tools used in hand forging but are larger and more robust. As far as possible, effort is made to finish the shape required in one heat only. Usually the bottom surface of the tup and the top of the anvil is flat as in the case of hand forging, but to increase production and cutdown cost, dies are often used. The top die, is fastened securely to the tup and the bottom die is fitted securely on the anvil. One half of the impression of the finished job is sunk in the top die, while in the bottom die, the other half of impression is sunk. The correct volume of raw material is heated in the furnace and a rough shape is first given to it. Thereafter it is placed on the bottom die and blows are given with the tup and top die. The material spreads to fill all the vacant space in the impressions sunk in the dies. Such a method of forging is called die forging.

Three types of die forging methods are prevalent. These are (i) Open die forging (ii) Impression die forging and (iii) Closed die forging.

OPEN DIE FORGING

In this type of forging, the metal is never completely enclosed or confined on all sides. Most open dies forgings are produced on flat, V or swaging dies. Swaging dies are usually round but may also be of other shapes e.g., double V. (Refer to Fig. 2.6).

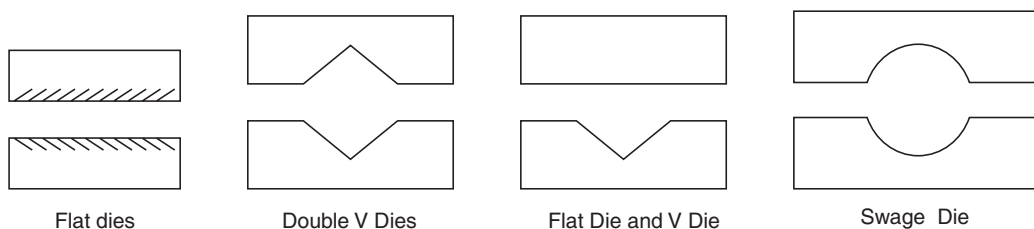

Fig. 2.6 Open dies

The common “upsetting” operation done on a hammer can also be considered as an example of open die forging with two flat dies as shown in Fig. 2.7.

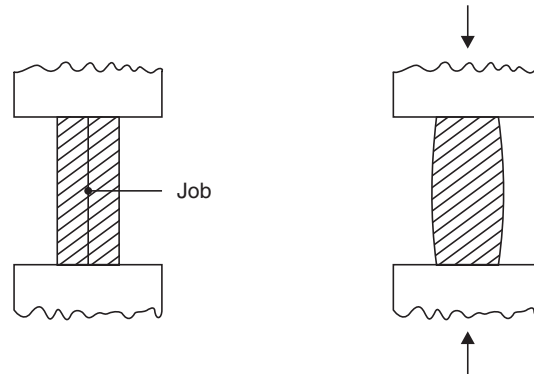

Fig. 2.7 Upsetting with open dies

Advantages claimed for open die forging are (i) Simple to understand and operate (ii) Inexpensive tooling and equipment as no die-sinking is involved and (iii) Wide range of work piece sizes can be accommodated. The main disadvantage is low volume of production and difficulty in close size control.

IMPRESSION DIE FORGING

Here half the impression of the finished forging is sunk or made in the top die and other half of the impression is sunk in the bottom die. The process of cutting the impression in a die is called die-sinking and is performed on a special kind of machine called die sinking machine.

In impression die forging, the work piece is pressed between the dies. As the metal spreads to fill up the cavities sunk in the dies, the requisite shape is formed between the closing dies. Some material which is forced out of the dies, is called “flash”. The flash provides some cushioning for the dies, as the tup strikes the anvil.

The flash around the work piece is cut and discarded as scrap. For a good forging, the impression in the dies have to be completely filled by the material. This may require several blows of the hammer, a single blow may not be sufficient. To facilitate the production of good forgings, the work piece may be given a rough shape by hand forging before die forging is done.

CLOSED DIE FORGING

Closed die forging is very similar to impression die forging, but in true closed die forging, the amount of material initially taken is very carefully controlled, so that no flash is formed. Otherwise, the process is similar to impression die forging. It is a technique which is suitable for mass production.

DROP STAMPING OR DROP FORGING HAMMERS

Very often, for closed die or impression die forging, a modified version of power hammer is used. It is called a drop stamping or drop forging hammer and gives better results. In this case, the tup is not an

integral part of the piston and the piston rod assembly, but is separate. The tup, to which the upper half of die is fixed is lifted by means of flexible ropes or a flexible canvas belting. It is then dropped on to the anvil to which the lower half of die is attached. Its downward movement is a gravity controlled free fall guided by the vertical guides provided in the frame of the hammer. The flexible ropes ensure, that after striking the anvil, the tup is free to rebound. Usually one fall of the tup may complete the forging. The metal piece is given a rough shape before being drop stamped.

SOME IMPORTANT CONSIDERATIONS LEADING TO SOUND FORGINGS

Hot forgings calls for work pieces to be heated to the correct forging temperature as mentioned before. In case the cross-section of the material to be forged is thick, we should allow enough “soaking” time for the heat to travel from the surface to the core of material. A thumb rule is to allow a soaking time of 30 minutes for every 12–15 mm of cross-sectional thickness. It is important that the entire cross-section should get heated to uniform temperature.

Good forging practice calls for a reduction of cross-section by roughly 40%. It is not correct to choose a cross-section for work piece material which is close to the finished size and forge it lightly or superficially to the required shape. If this is done, the mechanical properties of the forging leave much to be desired. One should remember that forging is not only a process for altering the shape of raw material to that required but this process can result in improved mechanical strength of the forged component as well.

One more point about good forging practice is to use as few “heats” for completion of forging as possible. It is also important to finish forging/hammering operations when the jobs has acquired a sufficiently low temperature; leaving forging at a high temperature will result in grain growth and will reduce the mechanical strength of the forged part. For mild steel, stop forging when the work piece has cooled down to about 450–500°C. To continue to hammer a cold work piece will only result in wasted effort and may even induce cracks in the material.

FORGING PRESSES

Occasionally, high capacity hydraulic presses are used for forging and the metal is shaped by squeezing action of the press rather than hammering action of hammer. Closed dies are used with impressions sunk in both dies, the upperdie is fixed on the ram and the lower die is fastened to the platen of the press. Presses are usually of a vertical configuration. Presses produce forgings of a superior structural quality.

MACHINE FORGING

For specific jobs like mass manufacture of bolts and nuts from bar stock, special forging machines have been developed. These machines work alongside a furnace in which one end of bar is heated for some length. The heated end of bar is then fed into the machine. With the help of dies and a heading tool, the hexagonal head of the bolt is forged by “upsetting”. These machines are in reality horizontal mechanical presses which can be operated by a foot pedal. The die consists of two halves and a heading tool. The sequence of operations can be understood from Fig. 2.8.

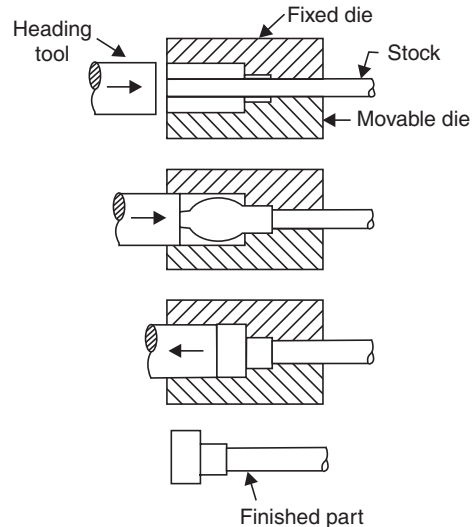

Fig. 2.8 Upset forging on machine

After the bolt head is forged, the bolt of required length can be had by shearing the bar at an appropriate place. The bar is then again inserted into the furnace for heating and the whole process is repeated.

FORGING DEFECTS

The common forging defects can be traced to defects in raw material, improper heating of material, faulty design of dies and improper forging practice.

Most common defects present in forgings are:

1. Laps and Cracks at corners or surfaces lap is caused due to following over of a layer of material over another surface. These defects are caused by improper forging and faulty die design.
2. Incomplete forging—either due to less material or inadequate or improper flow of material.
3. Mismatched forging due to improperly aligned die halves.
4. Scale pits—due to squeezing of scales into the metal surface during hammering action.
5. Burnt or overheated metal—due to improper heating.
6. Internal cracks in the forging which are caused by use of heavy hammer blows and improperly heated and soaked material.
7. Fibre flow lines disruption due to very rapid plastic flow of metal.

HEAT TREATMENT OF FORGINGS

The forged components may be subjected to severe stresses in service. To improve service life, to improve properties, to remove internal stresses and sometimes to improve the machinability, forgings may be given a suitable heat treatment after completing forging operations. Most common heat treatment given is normalising.

COLD FORGING

Limited formability at room temperature restricts the use of cold forging to low and medium carbon steels and for products where not much deformation is required to obtain final form. Usually the stock is in the form of wire or thin rods at one end of which a head is formed in a cold upsetting operation. Usually a mechanical press is used. Some typical products include nails, small diameter rivets pins, brass bolts etc.

QUESTIONS

1. Describe the process of “forge welding” in brief.
2. Explain the following processes connected with forging:
 - (i) Upsetting
 - (ii) Drawing down
 - (iii) Swaging.
3. How is a drop stamping hammer different from other power hammers ?
4. What do you understand by “die forging” ? Explain the difference between open and closed die forging techniques.
5. Describe some common forging defects and their causes.

Rolling

INTRODUCTION

In this process, metals and alloys are plastically deformed into semifinished or finished products by being pressed between two rolls which are rotating. The metal is initially pushed into the space between two rolls, thereafter once the roll takes a “bite” into the edge of the material, the material gets pulled in by the friction between the surfaces of the rolls and the material. The material is subjected to high compressive force as it is squeezed (and pulled along) by the rolls. This is a process to deal with material in bulk in which the cross-section of material is reduced and its length increased. The final cross-section is determined by the impression cut in the roll surface through which the material passes and into which it is compressed. The essentials of the rolling process can be understood from the Fig. 3.1.

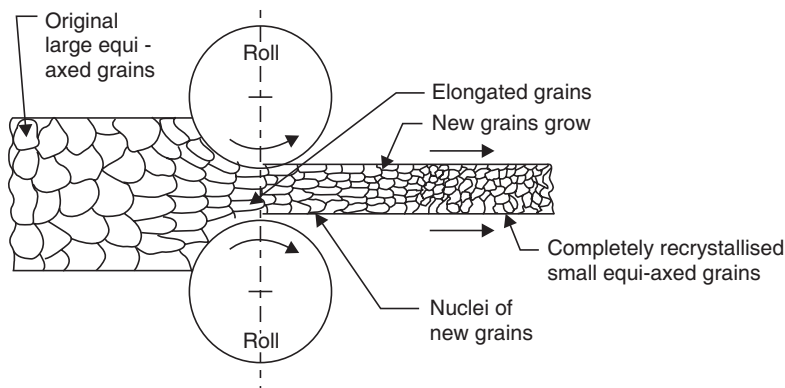

Fig. 3.1 Rolling Process

Rolling is done both hot and cold. In a rolling mill attached to a steel plant, the starting point is a cast ingot of steel which is broken down progressively into blooms, billets and slabs. The slabs are further hot rolled into plate, sheet, rod, bar, rails and other structural shapes like angles, channels etc. Conversion of steel into such commercially important sections is usually done in another rolling mill called merchant mill.

Rolling is a very convenient and economical way of producing commercially important sections. In the case of steel, about three-fourth's of all steel produced in the country is ultimately sold as a rolled product and remaining is used as forgings, extruded products and in cast form. This shows the importance of rolling process.

NOMENCLATURE OF ROLLED PRODUCTS

The following nomenclature is in common usage:

(i) **Blooms:** It is the first product obtained from the breakdown of Ingots. A bloom has a cross-section ranging in size from 150 mm square to 250 mm square or sometimes 250×300 mm rectangle.

(ii) **Billet:** A billet is the next product rolled from a bloom. Billets vary from 50 mm square to 125 mm square.

(iii) **Slab:** Slab is of rectangular cross-section with thickness ranging from 50 to 150 mm and is available in lengths up to $1\frac{1}{2}$ metres.

(iv) **Plate:** A plate is generally 5 mm or thicker and is 1.0 or 1.25 metres in width and 2.5 metres in length.

(v) **Sheet:** A sheet is up to 4 mm thick and is available in same width and length as a plate.

(vi) **Flat:** Flats are available in various thickness and widths and are long strips of material of specified cross-section.

(vii) **Foil:** It is a very thin sheet.

(viii) **Bar:** Bars are usually of circular cross-section and of several metres length. They are common stock (raw material) for capstan and turret lathes.

(ix) **Wire:** A wire is a length (usually in coil form) of a small round section; the diameter of which specifies the size of the wire.

MECHANISM OF ROLLING

Refer to Fig. 3.2. Each of the two rolls contact the metal surface along the arc AB , which is called arc of contact. Arc AB divided by the radius of rolls will give angle of contact (α). The rollers pull the material forwards only due to the friction existing between roll surface and the metal. At the moment of the bite, the reaction at the contact point A will be R acting along radial line O_1A and frictional force will be acting along tangent at A at right angles to O_1A . In the limiting case,

$$R \sin \alpha = \mu R \cos \alpha$$

$$\therefore \mu = \tan \alpha \quad \text{or} \quad \alpha = \tan^{-1} \mu$$

If α is greater than $\tan^{-1} \mu$, the material would not enter the rolls unaided.

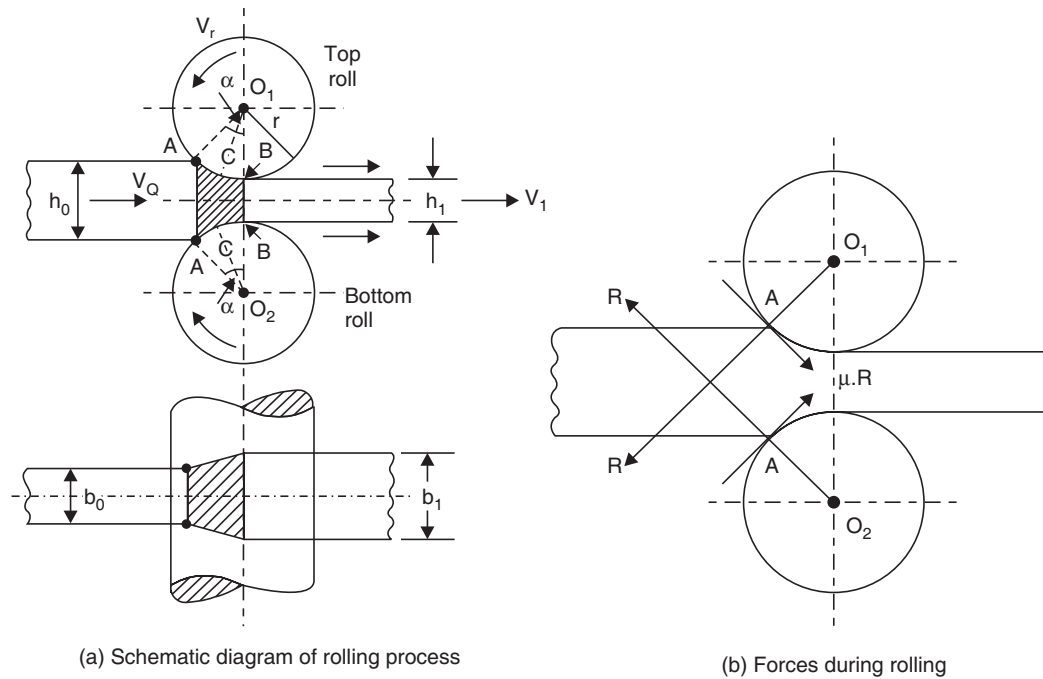

(a) Schematic diagram of rolling process

(b) Forces during rolling

Fig. 3.2 Rolling process

As will be seen, $\cos \alpha = \frac{r - \frac{1}{2}(h_0 - h_1)}{r}$, where h_0 is the thickness of material, h_1 the gap

between the two rollers at the narrowest point and r is the radius of rollers. For a given diameter of rollers and gap between them the value of h_0 is limited by the value of μ which in turn depends upon the material of rolls and job being rolled, the roughness of their surfaces and the rolling temperature and speed.

In case of hot rolling when maximum reduction in cross-section per pass is aimed at, it may be necessary to artificially increase the value of μ by “ragging” the surface of rolls. Ragging means making the surface of rolls rough by making fine grooves on the roll-surface. However, in cold rolling which is a finishing operation and cross-section reduction is limited, ragging of rolls is neither required nor desirable. In fact, in that case, some lubrication is resorted to in addition to giving a fine finish to the rolls. Another reason for making do with a lower coefficient of friction in cold rolling is that in this process, very high pressures are used and even with a low value of μ , adequate frictional force becomes available.

The usual values of biting angles employed in industry are:

- | | | |
|--------|-----|--|
| 2–10° | ... | for cold rolling of sheets and strips; |
| 15–20° | ... | for hot rolling of sheets and strips; |
| 24–30° | ... | for hot rolling of heavy billets and blooms. |

In the rolling process, although the material is being squeezed between two rolls, the width (b_0) of the material does not increase or increases only very slightly. Since volume of material entering the rolls is equal to the volume of material leaving the rolls, and the thickness of material reduces from h_0 to h_1 , the velocity of material leaving the rolls must be higher than the velocity of material entering the rolls. The rolls are moving at a uniform r.p.m. and their surface speed remains constant. The rolls are trying to carry the material into the rolls with the help of friction alone, there is no positive grip between rolls and the material. On one side, therefore, *i.e.*, point A where contact between the rolls and work material starts, the rolls are moving at faster surface speed than the work material. As the material gets squeezed and passes through the rollers, its speed gradually increases and at a certain section CC (Fig. 3.2) called neutral or no slip section, the velocity of metal equals the velocity of rolls. As material is squeezed further, its speeds exceeds the speed of the rolls. The angle subtended at the centre of the roll at the neutral section is called angle of no slip or critical angle (angle BO_1C).

The deformation zone to the left of the neutral section is called lagging zone and the deformation zone to the right of the neutral section is termed leading zone. If V_r is the velocity of roll surface, V_0 the velocity of material at the entrance to the deformation zone and V_1 at the exit of the rolls, we have

$$\text{Forward slip} = \frac{V_1 - V_r}{V_r} \times 100 \text{ per cent,}$$

and
$$\text{Backward slip} = \frac{V_r - V_0}{V_r} \times 100 \text{ per cent}$$

The value of forward slip normally is 3–10% and increases with increase in roll dia and coefficient of friction and also with reduction in thickness of material being rolled.

Some other useful terms associated with rolling are explained below:

$$\text{Absolute draught } \Delta h = (h_0 - h_1) \text{ mm,}$$

$$\text{Relative draught} = \frac{\Delta h}{h_0} \times 100 \text{ per cent}$$

$$\text{Absolute elongation, } \Delta l = \text{Final length} - \text{Original length of work material}$$

$$\text{Coefficient of elongation} = \frac{\text{Final length}}{\text{Original length}}$$

$$\text{Absolute spread} = \text{Final width of work material} - \text{Original width of material}$$

(**Note:** During cold working absolute spread may be taken as nil.)

TYPES OF ROLLING MILLS

Different types of rolling mills are described below in brief:

(i) **Two high mills:** It comprises of two heavy rolls placed one over the other. The rolls are supported in bearings housed in sturdy upright frames (called stands) which are grouted to the rolling mill floor. The vertical gap between the rolls is adjustable. The rolls rotate in opposite directions and are driven by powerful electrical motors. Usually the direction of rotation of rolls cannot be altered, thus

the work has to be fed into rolls from one direction only. If rolling entails more than one 'pass' in the same set of rolls, the material will have to be brought back to the same side after the first pass is over.

Since transporting material (which is in red hot condition) from one side to another is difficult and time consuming (material may cool in the meantime), a "two high reversing mill" has been developed in which the direction of rotation of rolls can be changed. This facilitates rolling of material by passing it through back and forth passes.

A two high rolling mill arrangement is shown in Fig. 3.3(a).

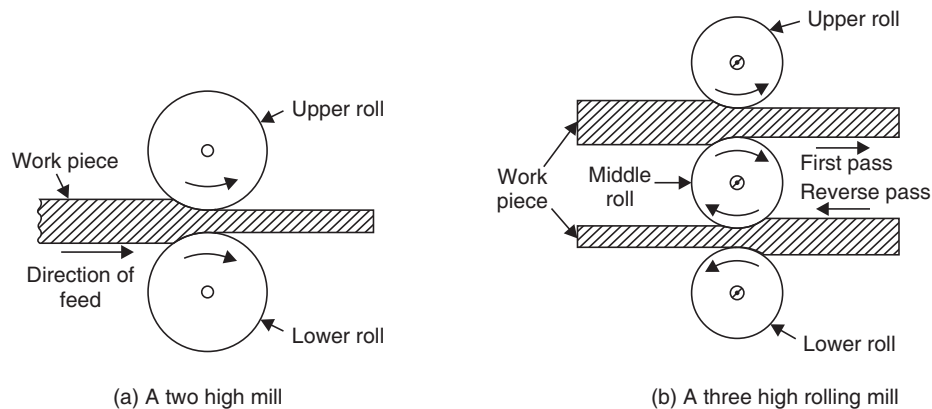

Fig. 3.3 Rolling mill types

(ii) **Three high mills:** A three high rolling mill arrangement is shown in Fig. 3.3(b). It consists of three rolls positioned directly over one another as shown. The direction of rotation of the first and second rolls are opposite as in the case of two high mill. The direction of rotation of second and third rolls are again opposite to each other. All three rolls always rotate in their bearings in the same direction. The advantage of this mill is that the work material can be fed in one direction between the first and second roll and the return pass can be provided in between the second and third rolls. This obviates the transport of material from one side of rolls to the other after one pass is over.

(iii) **Four high mills:** As shown in Fig. 3.4, this mill consists of four horizontal rolls, two of smaller diameter and two much larger ones. The larger rolls are called backup rolls. The smaller rolls are the working rolls, but if the backup rolls were not there, due to deflection of rolls between stands, the rolled material would be thicker in the centre and thinner at either end. Backup rolls keep the working rolls pressed and restrict the deflection, when the material is being rolled. The usual products of these mills are hot and cold rolled plates and sheets.

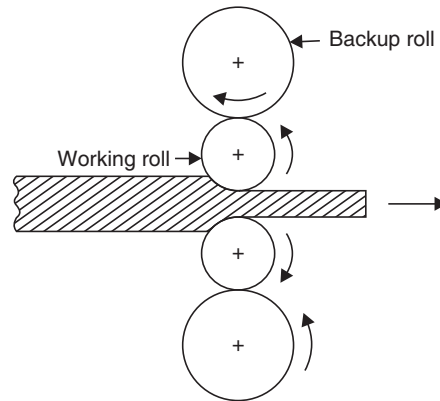

Fig. 3.4 Four high mill

(iv) **Cluster mills:** It consists of two working rolls of small diameter and four or more backing rolls. The large number of backup rolls provided becomes necessary as the backup rolls cannot exceed the diameter of working rolls by more than 2–3 times. To accommodate processes requiring high rolling loads (*e.g.*, cold rolling of high strength steels sheets), the size of working rolls becomes small. So does the size of backup rolls and a stage may be reached that backup rolls themselves may offer deflection. So the backup rolls need support or backing up by further rolls. In the world famous SENDZIMIR MILL, as many as 20 backup rolls are used in the cluster. This mill is used for rolling stainless steel and other high strength steel sheets of thin gauge.

ROLLS AND ROLL PASS DESIGN

Two types of rolls—Plain and Grooved are shown in Fig. 3.5. Rolls used for rolling consists of three parts *viz.*, body, neck and wabblers. The necks rest in the bearings provided in the stands and the star-shaped wabblers are connected to the driving shaft through a hollow cylinder. Wabblers act like a safety device and saves the main body of the roll from damage if too heavy a load causes severe stresses. The actual rolling operation is performed by the body of the roll.

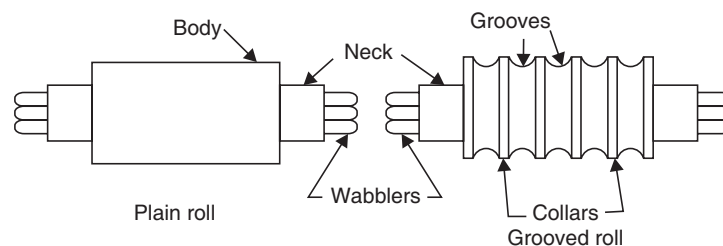

Fig. 3.5 Types of rolls

The rolls are generally made from a special variety of cast iron, cast steel or forged steel. Plain rolls have a highly finished hard surface and are used for rolling flats, plates and sheets. Grooved rolls

have grooves of various shapes cut on their periphery. One-half of the required shape of rolled product is sometimes cut in the lower roll and one-half in the upper roll, so that when the rolls are assembled into its stands, the required shape in full will be produced on the work material, once it passes (*i.e.*, rolled) through the groove in question. However it should be understood that the desired shape of the rolled section is not achieved in a single pass. The work material has to be rolled again and again through several passes and each pass brings the cross-section of the material closer to the final shape required. These passes are carefully designed to avoid any rolling defect from creeping in. Rolling is a painstaking process as would be noticed from the scheme of passes shown in Fig. 3.6 for conversion of a steel billet into a round bar.

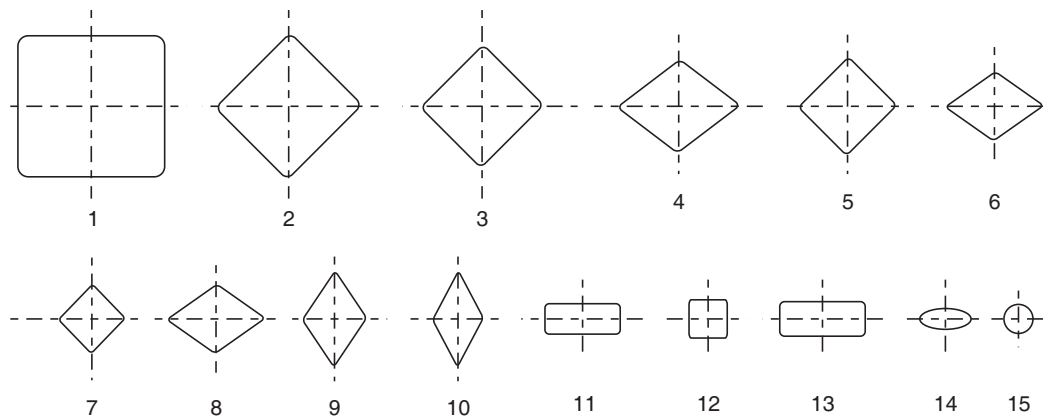

Fig. 3.6 Various stages of rolling and number of passes for converting a steel billet into a round bar

Various passes fall into the following groups:

- (i) Breakdown or roughing passes,
- (ii) Leader passes, and
- (iii) Finishing passes.

Breakdown passes are meant to reduce the cross-sectional area. The leader passes gradually bring the cross-section of the material near the final shape. The final shape and size is achieved in finishing passes. Allowance for shrinkage on cooling is given while cutting the finishing pass grooves.

RING ROLLING

Seamless (*i.e.*, without a joint) rings find wide application in industry. The inner and outer races of ball and roller bearings, steel tyres for railway wheel are some such applications. These rings are made by a special rolling process called ring rolling. The starting work piece is a thick walled circular piece of metal in whose centre a hole has been made by drifting and piercing. The work piece is heated until it becomes red hot and then placed between two rolls *A* and *B* which rotate in opposite directions. The arrangement of rolls and the ring is shown in Fig. 3.7.

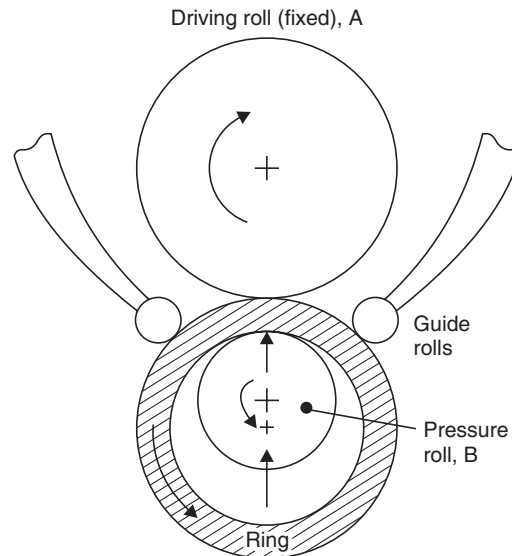

Fig. 3.7 Ring rolling

The pressure roll *B* exerts pressure on the material from inside. Caught between rolls *A* and *B*, the ring rotates. At the same time, the inside and outside dia of ring progressively increase and the wall thickness keeps on reducing. In order to ensure that the ring is circular, two guide rolls are suitably placed on the outer surface of the ring. When the outer and inner dia of the ring increase to the size required, the rolling is stopped.

COLD ROLLING

Hot rolled steel products look an unattractive greyish-black in colour. Non-ferrous materials also develop a tarnished colouring due to oxidation of outer surface. The surface finish is rough and the finished sizes of hot rolled products are far from satisfactory. In case of steel, the oxidation of carbon present in the surface leads to decarburisation. However hot rolling is very economical as due to increased plasticity, large reductions in cross-section are quickly achieved with low energy consumption. A great deal of hot rolled “black” bars and sheets/plates of steel are used in construction industry for fabrication of structures.

Thinner gauges, better surface finish, tighter size control and “bright” surfaces are obtained in cold rolling process. These products also develop greater strength and wear resistance due to strain hardening.

The effect of mechanical work done (*i.e.*, strain hardening) is automatically nullified in hot rolling process, as recrystallisation in the hot worked material keeps on taking place simultaneously. This is shown schematically in Fig. 3.8.

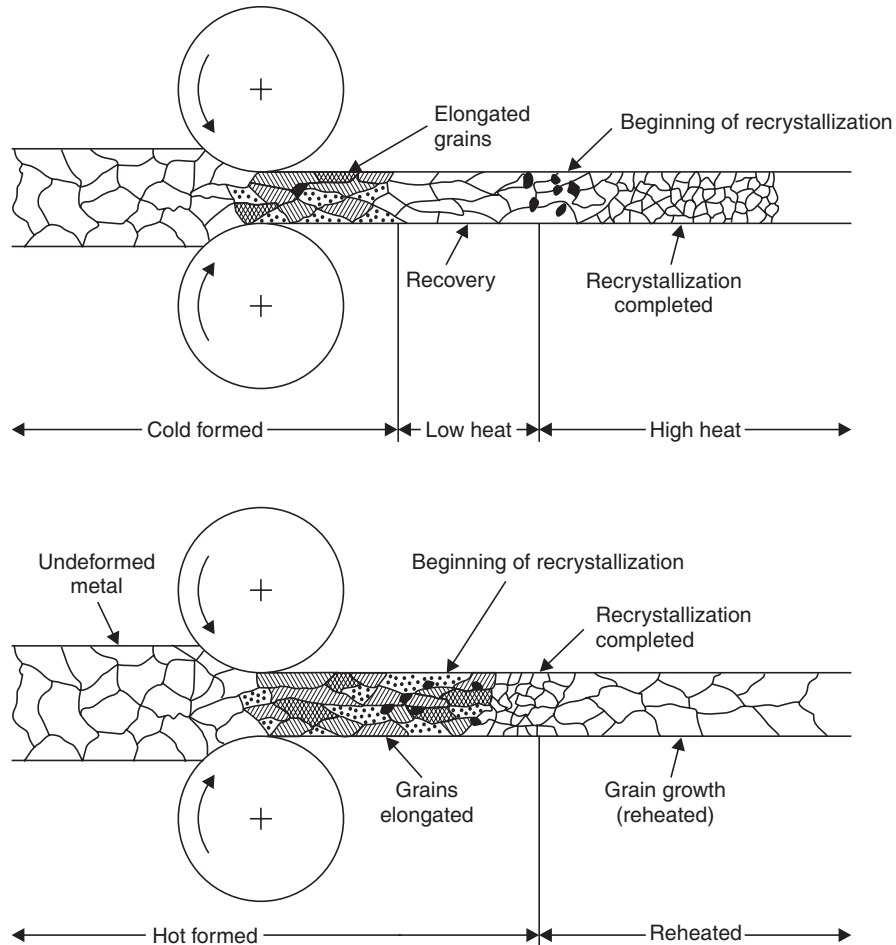

Fig. 3.8 Effect of both cold working and hot working on the microstructure of metals

Thus the actual process employed in the industry for production of small gauge material is hot rolling to slightly above finished size required, cleaning/removing the oxidised surface by machining pickling or some other suitable process and finally using cold-rolling of work-material to finished sizes.

ROLLING DEFECTS

To understand the causes and remedies of rolling defects, we shall divide them in two classes:

1. Surface defects, and
2. Structural defects.

Surface defects include rusting and scaling, surface scratches, surface cracks, pits left on the surface of due to subsequent detachment or removal of scales which may have been pressed into the surface.

Structural defects are more important rolling defects some of which are difficult to remedy. These defects include the following:

- (i) Wavy edges
- (ii) Zipper cracks
- (iii) Edge cracks
- (iv) Centre split
- (v) Alligating
- (vi) Folds
- (vii) Laminations.

Wavy edges and zipper cracks: These defects are caused due to bending of rolls under the rolling pressure. A roll can be considered as a beam supported in its stands. Under rolling pressure, the rolls deflect in the manner shown in Fig. 3.9. Consequently the work material becomes thinner at the two edges and thicker in the central portion. In other words, it means that material becomes longer as measured along the edges than in centre. This causes tensile stress in the centre and compressive stress in the edges. The former causes zipper cracks in the centre and the latter causes wavy edges.

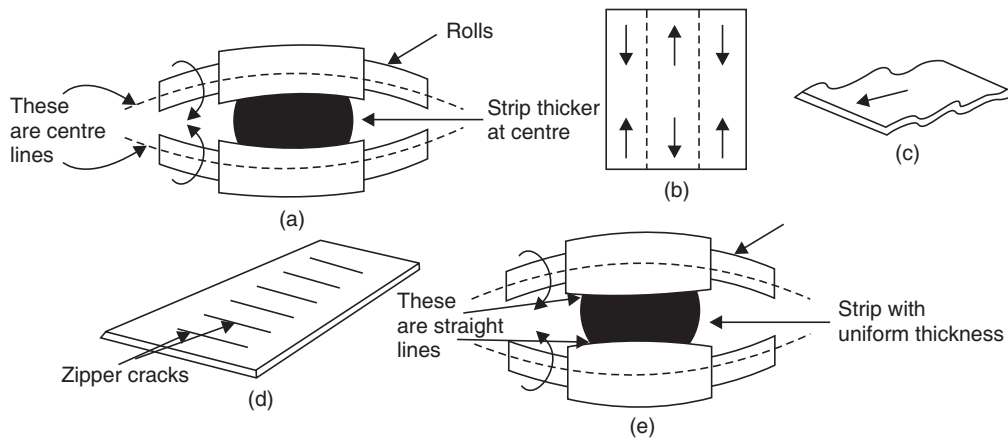

Fig. 3.9 Rolling defects

Remedy for zipper cracks and wavy edges lies in provide a “camber” to the rolls. They are made slightly convex in the central portion to offset the effect of deflection under rolling loads.

Edgcracks and centre split: These defects are caused due to non homogeneous plastic deformation of metal across the width. As the work piece passes through the rolls, under the rolling pressure its height decreases while its length increases. Some lateral spread *i.e.*, increase in width also takes place. However the lateral spread is more towards the edges than in the centre as there is little resistance to lateral spread towards the edges. In the centre lateral spread is resisted by friction and the adjacent layer of material. Hence decrease in lateral spread in the central portion of work material results in greater increase in length in this region as compared to the edges. This effect is shown in Fig. 3.10.

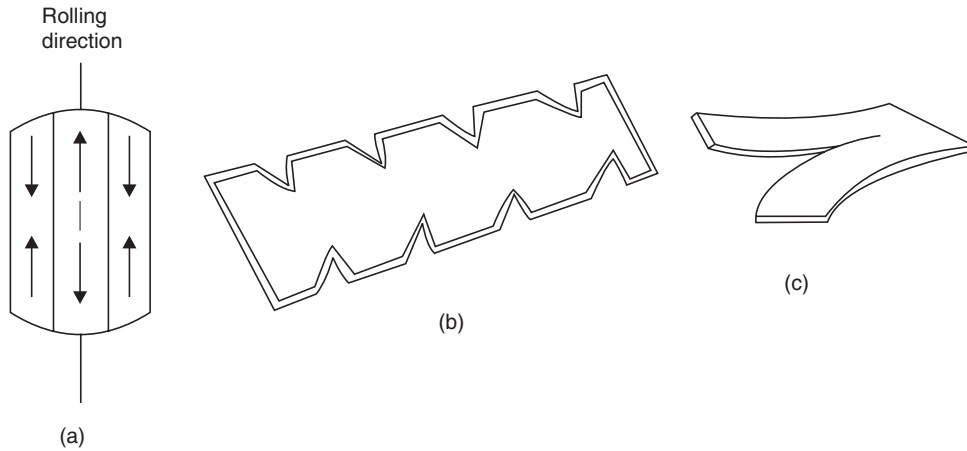

Fig. 3.10 Rolling defect

It can be realised that under such non homogeneous deformation of work material, the edges experience a tension (as the central portion tries to pull it due to continuity of material) and the central portion experience a compressive stress. Such a distribution of stress may result in edge crack or in severe cases, it may even lead to a split along the central portion.

Alligatoring: As pointed out earlier, rolling entails a reduction in the height with consequent increase in length. But due to friction present at the interface of the rolls and upper and lower surfaces of the work material, the elongation on the top and bottom surfaces is less than the material located at the centre of thickness of the work piece. If conditions become severe, it may cause a defect called “alligatoring” *i.e.*, rupture of material along the length into an upper half and a lower half resembling the open mouth of an alligator. The defect is illustrated in Fig. 3.11.

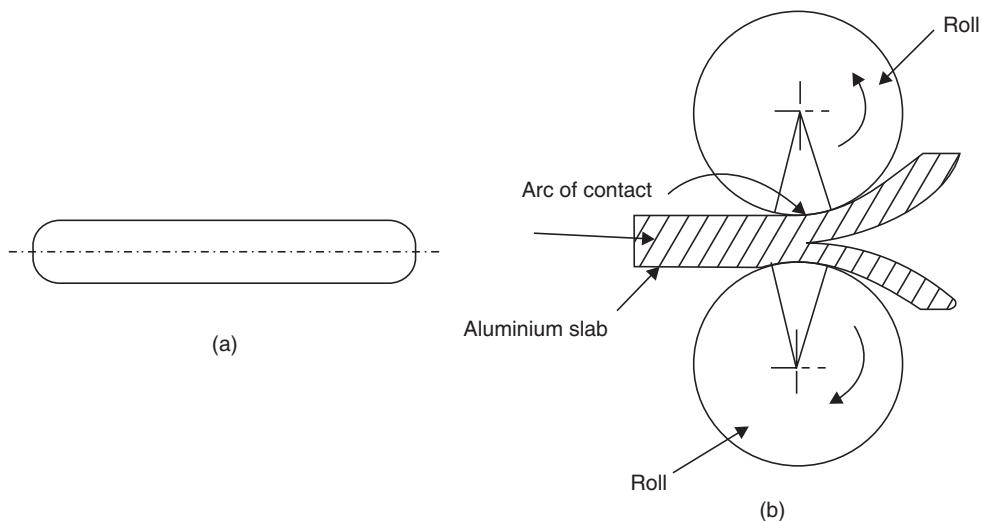

Fig. 3.11 Rolling defect (alligatoring)

Folds: This defect is encountered when the reduction per pass is very low.

Laminations: Laminations mean layers. If the ingot is not sound and has a piping or blow holes and during rolling they do not get completely welded (*e.g.*, if the piping has got oxidised material or non-metallic inclusions it will not get welded), it will cause a defect called laminations. Very often in the ingot, there are non-metallic inclusions; during rolling they will get lengthened along with sound material. This may also cause laminations.

These defects can only be remedied by discarding the portion of the ingot where piping and other defects are present and selecting only good metal portion for rolling.

QUESTIONS

1. Describe the process of rolling. Illustrate your answer with a suitable explanatory sketch.
2. How is cold rolling done? What are the differences between hot rolled and cold rolled products?
3. Bring out the difference between two-high, three-high and four high rolling mills.
4. Describe the process of ring rolling. Name some typical parts manufactured by this process.
5. Describe some common rolling defects. How can they be remedied?

Extrusion, Wire Drawing, Tube Drawing and Making

Extrusion is a process in which the metal is subjected to plastic flow by enclosing the metal in a closed chamber in which the only opening provided is through a die. The material is usually treated so that it can undergo plastic deformation at a sufficiently rapid rate and may be squeezed out of the hole in the die. In the process the metal assumes the opening provided in the die and comes out as a long strip with the same cross-section as the die-opening. Incidentally, the metal strip produced will have a longitudinal grain flow.

The process of extrusion is most commonly used for the manufacture of solid and hollow sections of nonferrous metals and alloys *e.g.*, aluminium, aluminium-magnesium alloys, magnesium and its alloys, copper, brass and bronze etc. However, some steel products are also made by extrusion.

The stock or the material to be extruded is in the shape of cast ingots or billets. Extrusion may be done hot or cold. The cross-sections of extruded products vary widely. Some of these sections are shown in Fig. 4.1.

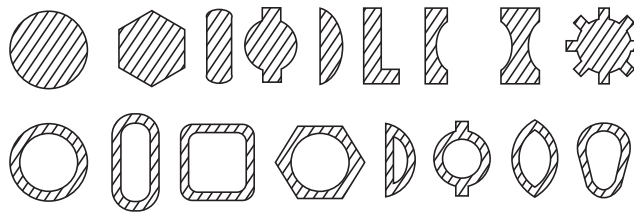

Fig. 4.1 Type of extrusions

Some advantages of extrusion process are described below:

(i) The complexity and range of parts which can be produced by extrusion process is very large. Dies are relative simple and easy to make.

(ii) The extrusion process is complete in one pass only. This is not so in case of rolling, amount of reduction in extrusion is very large indeed. Extrusion process can be easily automated.

(iii) Large diameter, hollow products, thin walled tubes etc. are easily produced by extrusion process.

(iv) Good surface finish and excellent dimensional and geometrical accuracy is the hall mark of extruded products. This cannot be matched by rolling.

Pressure required for extrusion depends upon the strength of material and upon the extrusion temperature. It will reduce if the material is hot. It will also depend upon the reduction in cross-section required and the speed of extrusion. There is a limit to the extrusion speed. If extrusion is done at a high speed, the metal may crack. The reduction of cross-sectional area required is also called “extrusion ratio”. There is a limit to this also. For steel extruded hot, this ratio should not exceed 40 : 1, but for aluminium extruded hot it can be as high as 400 : 1.

EXTRUSION PROCESSES

Extrusion processes can be classified as followed:

(A) Hot Extrusion

- (i) Forward or Direct extrusion.
- (ii) Backward or Indirect extrusion.

(B) Cold Extrusion

- (i) Hooker extrusion.
- (ii) Hydrostatic extrusion.
- (iii) Impact extrusion.
- (iv) Cold extrusion forging.

A. Hot Extrusion Processes

(i) **Forward or direct extrusion process:** In this process, the material to be extruded is in the form of a block. It is heated to requisite temperature and then it is transferred inside a chamber as shown in Fig. 4.2. In the front portion of the chamber, a die with an opening in the shape of the cross-section of the extruded product, is fitted. The block of material is pressed from behind by means of a ram and a follower pad. Since the chamber is closed on all sides, the heated material is forced to squeeze through the die-opening in the form of a long strip of the required cross-section.

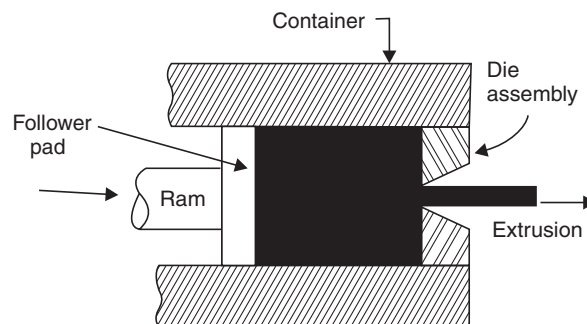

Fig. 4.2 Forward or direct extrusion

The process looks simple but the friction between the material and the chamber walls must be overcome by suitable lubrication.

When extruding steel products, the high temperature to which the steel has to be heated makes it difficult to find a suitable lubricant. The problem is solved by using molten glass as a lubricant. When lower temperatures are used, a mixture of oil and graphite is used as a lubricant.

At the end of the extrusion process, a small piece of metal is left behind in the chamber which cannot be extruded. This piece is called butt—end scrap and is thrown away. To manufacture a tubular rod, a mandrel of diameter equal to that of tube—bore is attached to the ram. This mandrel passes centrally through the die when the material is extruded. The outside diameter of the tube produced will be determined by the hole in the die and the bore of tube will be equal to mandrel diameter. The extrusion process will then be called “tubular extrusion”.

(ii) **Backward or indirect extrusion:** This process is depicted in Fig. 4.3. As shown, the block of heated metal is inserted into the container/chamber. It is confined on all sides by the container walls except in front; where a ram with the die presses upon the material. As the ram presses backwards, the material has to flow forwards through the opening in the die. The ram is made hollow so that the bar of extruded metal may pass through it unhindered.

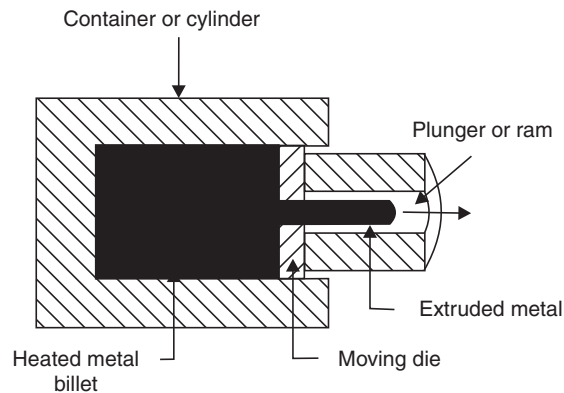

Fig. 4.3 Backward or indirect extrusion

This process is called backward extrusion process as the flow of material is in a direction opposite to the movement of the ram. In the forward extrusion process the flow of material and ram movement were both in the same direction. The following table compares the forwards (direct) and backwards (indirect extrusion process):

Table 4.1

<i>Forward or direct extrusion</i>	<i>Backward or indirect extrusion</i>
1. Simple, but the material must slide along the chamber wall.	1. In this case, material does not move but die moves.
2. High friction forces must be overcome.	2. Low friction forces are generated as the mass of material does not move.
3. High extrusion forces required but mechanically simple and uncomplicated.	3. 25–30% less extruding force required as compared to direct extrusion. But hollow ram required limited application.
4. High scrap or material waste—18–20% on an average.	4. Low scrap or material waste only 5–6% of billet weight.

B. Cold Extrusion Processes

(i) **Hooker extrusion process:** This process is also known as extrusion down method. It is used for producing small thin walled seamless tubes of aluminium and copper. This is done in two stages. In the first stage the blank is converted into a cup shaped piece. In the second stage, the walls of the cup are thinned and it is elongated. The process can be understood by referring to Fig. 4.4. This process is a direct extrusion process.

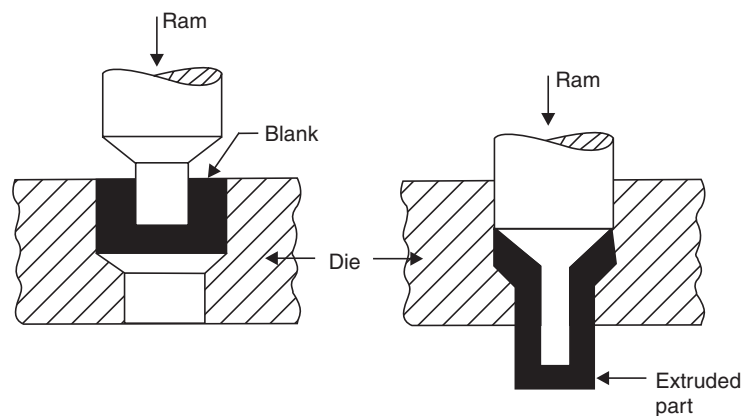

Fig. 4.4 Hooker extrusion

(ii) **Hydrostatic extrusion:** This is a direct extrusion process. But the pressure is applied to the metal blank on all sides through a fluid medium. The fluids commonly used are glycerine, ethyl glycol, mineral oils, castor oil mixed with alcohol etc. Very high pressures are used – 1000 to 3000 MPa. Relatively brittle materials can also be successfully extruded by this method.

(iii) **Impact extrusion:** In this process, which is shown in Fig. 4.5 the punch descends with high velocity and strikes in the centre of the blank which is placed in a die. The material deforms and fills up the annular space between the die and the punch flowing upwards. Before the use of laminated plastic for manufacturing tooth paste, shaving cream tubes etc., these collapsible tubes containing paste were and are still made by this process. This process is actually a backward extrusion process.

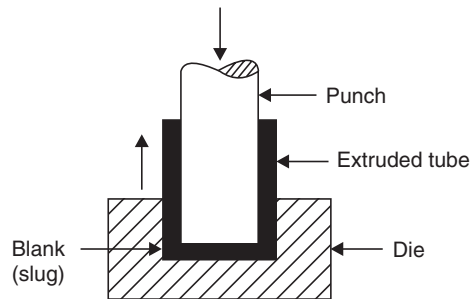

Fig. 4.5 Impact extrusion

(iv) **Cold extrusion forging:** This process is depicted in Fig. 4.6. This is generally similar to the impact extrusion process; but there are two differences:

1. In this process the punch descends slowly, and
2. The height of extruded product is short and the side walls are much thicker than the thin walled products produced by the impact extrusion process. In essence, this process is one of backward extrusion.

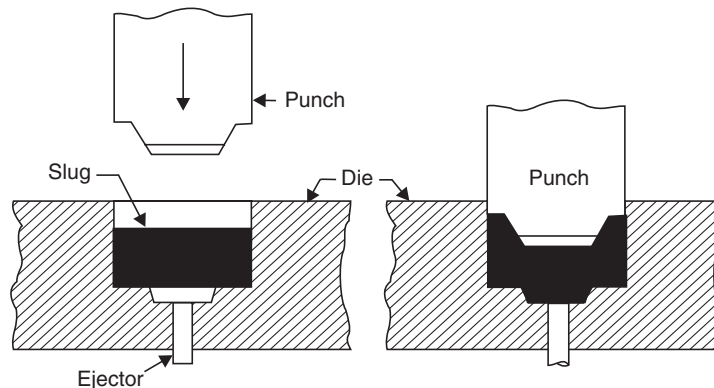

Fig. 4.6 Cold extrusion forging

Comparison between Hot and Cold Extrusion

This is given in the following table:

Table 4.2

<i>Cold extrusion</i>	<i>Hot extrusion</i>
1. Better surface finish and lack of oxide layers.	1. Surface is coated with oxide layers. Surface finish not comparable with cold extrusion.
2. Good control of dimensional tolerance—no machining or very little machining required.	2. Dimensional control not comparable with cold extrusion products.
3. High production rates at low cost. Fit for individual component production.	3. High production rates but process fit for bulk material, not individual components.
4. Improved mechanical properties due to strain hardening.	4. Since processing is done hot, recrystallisation takes place.
5. Tooling subjected to high stresses.	5. Tooling subjected to high stresses as well as to high temperature. Tooling stresses are however lower than for cold extrusion.
6. Lubrication is crucial.	6. Lubrication is crucial.

MACHINES FOR EXTRUSION

Both hydraulic and mechanical presses of horizontal and vertical configuration are used for extrusion. They should be capable of exerting high forces and their rams should have long strokes. To reduce friction between metal and extrusion chamber walls, lubricants are used. The dies and punches are made from good quality alloy steels which are known as hot and cold die steels.

Extrusion speed is of the order of 0.5 m/sec for light alloys and 4.5 m/sec for copper alloys.

EXTRUSION DEFECTS

Sometimes the surface of extruded metal/products develop surface cracks. This is due to heat generated in the extrusion process. These cracks are specially associated with aluminium, magnesium and zinc alloy extrusions.

The extruded product can develop internal cracks also. These are variously known as centre burst, centre cracking and arrowhead fracture. The tendency for centre cracking increases with increasing die angles and material impurities.

WIRE DRAWING

Wire drawing is a simple process. In this process, rods made of steel or non ferrous metals and alloys are pulled through conical dies having a hole in the centre. The included angle of the cone is kept between 8 to 24°. As the material is pulled through the cone, it undergoes plastic deformation and it gradually undergoes a reduction in its diameter. At the sametime, the length is increased proportionately. The process is illustrated in Fig. 4.7.

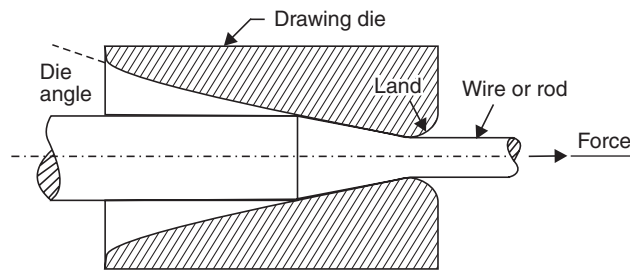

Fig. 4.7 Wire drawing process

The dies tend to wear out fast due to continuous rubbing of metal being pulled through it. Hence they are made of very hard material like alloy steel, tungsten carbide or even diamond. In one pass, the reduction in cross-sectional area achieved is about 25–30%. Hence in a wire drawing plant, the wire has to pass through a number of dies of progressively reducing diameter to achieve the required reduction in diameter. However as the wire passes through dies and undergoes plastic deformation, it gets strain hardened. Its strength increases and capacity to further undergo plastic deformation decreases. Therefore during the entire run of the wire, from time to time, it has to be heated (and cooled) to remove the effect of work-hardening. This process is called “in process annealing”. The aim is to make the material soft and ductile again so that the process of drawing may be smoothly carried out.

The metal rods to be drawn into wires must be absolutely clean. If necessary, they are pickled in an acid bath to dissolve the oxide layer present on the surface. Its front end is then tapered down so that it may pass through the hole in the die which is firmly held in the wire drawing machine. The wire is drawn by means of a number of power driven spools or rotating drums.

During wire drawing, a great deal of heat is generated due to friction between the wire rod and the die. To reduce friction, dry soap or a synthetic lubricant is used. But despite reducing friction, the dies and drums may have to be water cooled.

The preferred material for dies is tungsten carbide but for drawing fine wire, use of ruby or diamond dies is preferred.

The drawing machines can be arranged in tandem so that the wire drawn by the previous die may be collected (in coil form) in sufficient quantity before being fed into the next die for further reduction in diameter. As the diameter becomes smaller, the linear speed of wire drawing is increased.

The major variables in wire drawing process are (1) Reduction ratio (2) Die angle and (3) Friction. Improper control of these parameters will cause defects in the drawn material. Defects include centre cracking (as in extrusion and for the same reasons) and formation of longitudinal scratches or folds in the material.

TUBE DRAWING

The ‘drawing’ process can also be used for tube drawing. Tube drawing does not mean manufacturing a tube from solid raw material. It means lengthening a tube reducing its diameter. Various arrangements used for tube drawing are shown in Fig. 4.8.

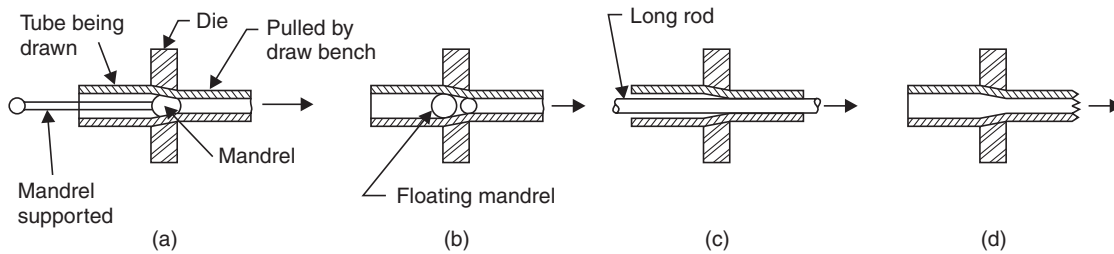

- Method (a) is most commonly used.
- Method (b) uses a floating mandrel which adjusts itself to the correct position because of its stepped contour.

Fig. 4.8 Tube drawing

The method shown in Fig. 4.8 (a) is the most common method used for tube drawing. A conventional tube drawing bench is used. Method shown in Fig. 4.8 (b) employs a floating mandrel. Method shown in Fig. 4.8 (c) uses a long circular rod to control the size of tube-bore. Method shown in Fig. 4.8 (d) uses neither a mandrel nor a bar and controlling size of bore is difficult.

TUBE MAKING

Tubes and pipes are required in large quantities by industries all over the world. Tubes are basically of two types. They are either seamless (*i.e.*, without any joint) or with joint all along the length of the tube. Seamless tubes are made by processes such as casting, extrusion or rolling. Tubes with joint are made by welding. Usually, the weld joint is made by electric resistance welding process, such tubes are referred to as ERW tubes. The size of a tube or pipe is indicated by the size of its bore in mm.

Since the requirement of tubes is so large, a special rolling process called Mannesmann rotary piercing process has been developed. In this process, a heated round billet with its leading end, in the centre of which a short guide hole has been punched or drilled, is pushed longitudinally between two large tapered rolls as shown in Fig. 4.9.

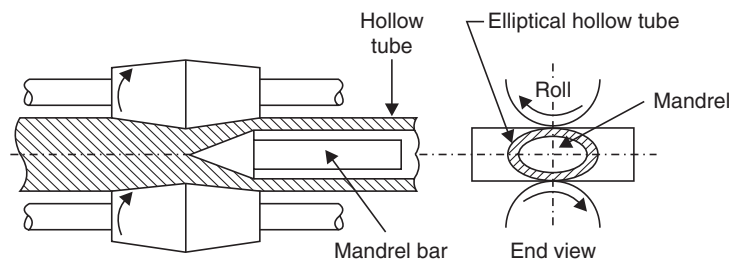

Fig. 4.9 Tube making

The rolls revolve in the same direction and their axes are inclined at opposite angles of approx 6° from the axis of the billet. As the billet is caught by the rolls and is rotated, their inclination causes the material to be drawn forward. The small clearance between the rolls forces the material to deform into an elliptical shape. Due to compressive forces, secondary tensile stresses start acting in a direction perpendicular to the direction of the compressive stresses. The guide hole drilled/punched at centre of billet tears open. This action is assisted by a suitably placed mandrel.

As the billet moves forward and keeps rotating the tearing action is propagated throughout the length of the billet. End result is a roughly formed seamless tube of elliptical cross-section.

This roughly formed seamless tube is further rolled in a “plug rolling mill”. The final operations of “reeling” and “sizing” are further conducted on cooled tube to improve size and finish of tubes.

QUESTIONS

1. Differentiate between extrusion and drawing processes. What is “in process” annealing and what is its object ?
2. Explain the difference between direct and indirect extrusion processes with the help of explanatory sketches.
3. Describe the tube-drawing process.
4. Describe the process of ‘tube making’. What is the difference between this process and tube rolling process ?
5. Explain how seamless tubes of aluminium-magnesium alloy can be mass-manufactured.

Press Work and Die-Punch Assembly

Use of mechanical and hydraulic presses for forging and extrusion has been mentioned earlier. Knuckle type mechanical presses are used widely for sheet metal work. These presses are usually of vertical configuration. These presses are provided with a heavy flywheel driven by an electric motor. A ram moves up and down the guide ways provided in the frame of the press, when the ram is connected to the flywheel through a connecting rod and a crank mechanism. The clutch for transferring the motion from the flywheel to the ram is operated by a foot operated treadle. The arrangement is somewhat similar to the mechanism of a reciprocating engine. Such presses are very useful for providing short powerful strokes.

These presses are available in two configurations:

- (i) Open frame type, and
- (ii) Closed frame type.

Open frame type presses are less robust as compared to closed frame type, but provide greater access for loading material as they are open in front as well as sides. Due to their appearance, they are also referred to as C-frame or gap presses as well. Closed frame type presses are used for heavier work. The capacity of the press is indicated by the force (or tonnage), the press is capable of exerting.

TOOLS

A set of dies is the required tooling for working with the presses. A die set consists essentially of three parts: (i) a punch (male tool), (ii) a die (a female tool) and (iii) stripper plate. The punch is fixed or bolted to the ram and the die is fixed on the machine bed in such a manner that the two are in perfect alignment. When the punch along with the ram of the press moves downwards, the punch passes centrally through the die.

A die and punch assembly for making holes in metal-sheets is shown in Fig. 5.1.

When the punch descends, it shears the metal-sheet. The hole punched through has the same profile as the punch. If the remaining portion of the sheet metal is the useful part, the punched out portion is thrown away as scrap. In this case, the operation is called “punching”. However, if the punch out portion is the useful part, the operation is termed “blanking” and the punched out piece is referred to as blank. The size of blank is determined by the size of hole in the die.

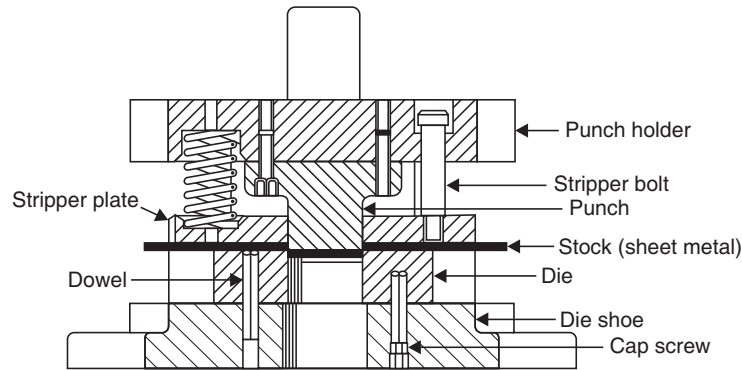

Fig. 5.1 Standard die set with a punch and die mounted in place

The function of the stripper plate is to keep the sheet held down during the subsequent upward movement of the punch; otherwise, the sheet may get entangled with the punch during the upward movement of the ram and the punch.

For efficient operation and clean cut surfaces, some clearance is provided between the punch and the die. It is a function of thickness of sheet under shear and is 3–5% of thickness. Actually, after the bottom surface of the punch comes into contact with the sheet, it travels or penetrates through the sheet upto about 40% of the sheet thickness inducing higher and higher compressive stress in the sheet metal. Ultimately, the resultant shear stress at the perimeter of the blank exceeds the maximum shear strength of the material and the blanks gets sheared off through the remaining 60% of the sheet thickness. The depth of penetration-zone and shear zone are demarcated and easily seen, if the periphery of the blank is examined visually.

The shear force Vs thickness graph is typical and is shown in Fig. 5.2.

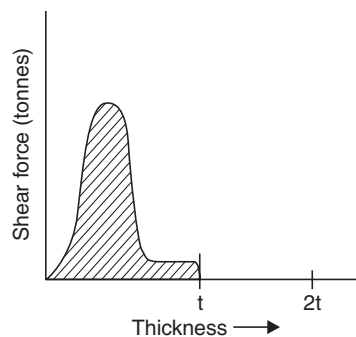

Fig. 5.2

The area under this curve (shown shaded) gives the energy required for the shearing operation.

The die and punch are made of high quality, fine grained alloy steel. They are then heat treated to develop high hardness, wear resistance and impact-resistance.

Sometimes, when no press capable of exerting full shear force is available, the bottom surface of the punch is given a taper. This is known as “shear”. Provision of shear reduces the maximum force required as the entire periphery of the punch will not bear on the sheet metal simultaneously.

OTHER OPERATIONS PERFORMED WITH PRESSES

Apart from punching and blanking, several other useful operations are performed with the help of mechanical presses:

Some of these are listed below:

- (i) Bending,
- (ii) Deep drawing,
- (iii) Coining, and
- (iv) Embossing.

These operations are described briefly.

BENDING

Bending means deforming a flat sheet along a straight line to form the required angle. Various sections like angles, channels etc., are formed by bending, which may then be used for fabrication of steel structures.

Three common methods of bending are illustrated in Fig. 5.3.

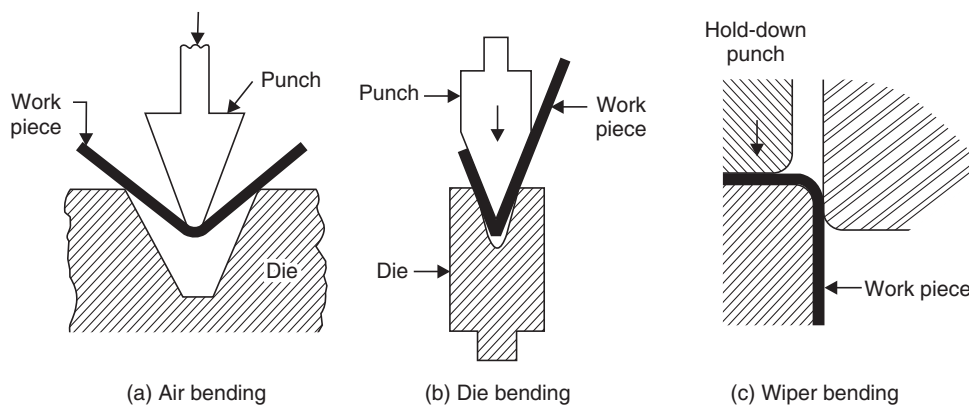

Fig. 5.3 Types of bending dies

The operation of bending is done with the help of a V-shaped punch, a die and press specially designed for such work. The stroke of such presses can be controlled at operator's will and such presses are called press brakes.

In V-bending, a V-shaped punch forces the metal sheet or a flat strip into a wedge-shaped die. The bend angle will depend upon the distance to which the punch depresses. Bends of 90° or obtuse as well as acute angle, may be produced.

Wiper bending is used only for 90° bends. Here the sheet is held firmly down on the die, while the extended portion of sheet is bent by the punch.

Spring back: At the end of the bending operation, after the punch exerting the bending force is retrieved, due to elasticity, there is a tendency for the bend angle to open out. This is called "spring back". The effect of spring back may be offset by slight overbending in the first place. Other methods to

prevent spring back are bottoming and ironing. For low carbon steels spring back is $1-2^\circ$, while for medium carbon steel it is $3-4^\circ$.

DEEP DRAWING

In deep drawing process, we start with a flat metal plate or sheet and convert it into cupshape by pressing the sheet in the centre with a circular punch fitting into a cup shaped die. In household kitchen, we use many vessels like deep saucepans (or BHAGONA), which are made by deep drawing process. If the depth of cup is more than half its diameter, the process is termed as deep drawing and with a lesser depth to diameter ratio, it is called shallow drawing. Parts of various geometries and shape are made by drawing process. The deep drawing process is illustrated in Fig. 5.4.

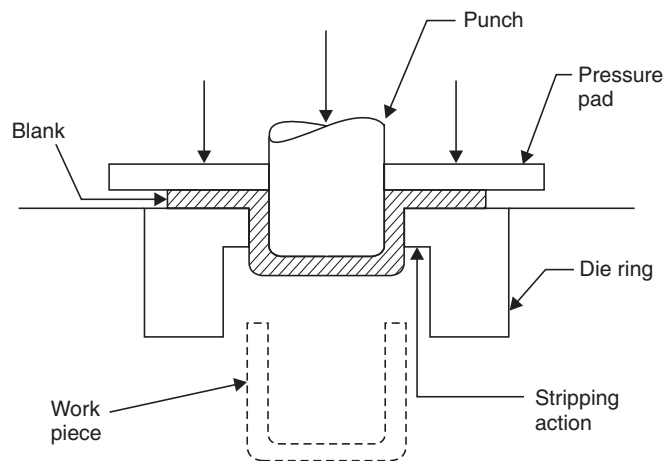

Fig. 5.4 Deep drawing operation

During the drawing process, the sheet metal part is subjected to a complicated pattern of stress. The portion of the blank between the die wall and punch surface is subjected to pure tension, whereas the portion lower down near the bottom is subject both to tension and bending. The portion of metal blank, which forms the flange at the top of the cup is subjected to circumferential compressive stress and buckling and becomes thicker as a result thereof. The flange has therefore to be held down by a pressure pad, otherwise, its surface will become buckled and uneven like an orange peel.

Deep drawing is a difficult operation and the material used should be specially malleable and ductile, otherwise it will crack under the induced stresses. The wall thickness of a deep drawn component does not remain uniform. The vertical walls become thinner due to tensile stresses. But the thinnest portion is around the bottom corner of the cup all around. This thinning of sheet at these locations is called “necking”.

After deep drawing, the component may be subjected to certain finishing operations like “ironing”, the object of which is to obtain more uniform wall thickness.

COINING AND EMBOSsing

Both coining and embossing operations are done 'cold' and mechanical presses with punch and die are used for these operations. In embossing, impressions are made on sheet metal in such a manner that the thickness of the sheet remains uniform all over even after embossing has been done. It means that if one side of the sheet is raised to form a design, there is a corresponding depression on the other side of the sheet. Basically it is a pressing operation where not much force is needed. The sheet is spread on the bottom die and the stroke of the punch is so adjusted that, when it moves down to its lowest position, it leaves a uniform clearance between the impressions carved in the punch and the die which is equal to the thickness of the sheet being embossed. The design is transferred on to the sheet by bending the sheet up or down without altering its thickness anywhere. Many decoration pieces with religious motifs are made in this way.

COINING

In coining process, a blank of metal which is softened by annealing process is placed between two dies containing an impression. The blank is restricted on its circumference in such a manner, that upon the two dies closing upon the blank, the material cannot flow laterally *i.e.*, sideways. The material is only

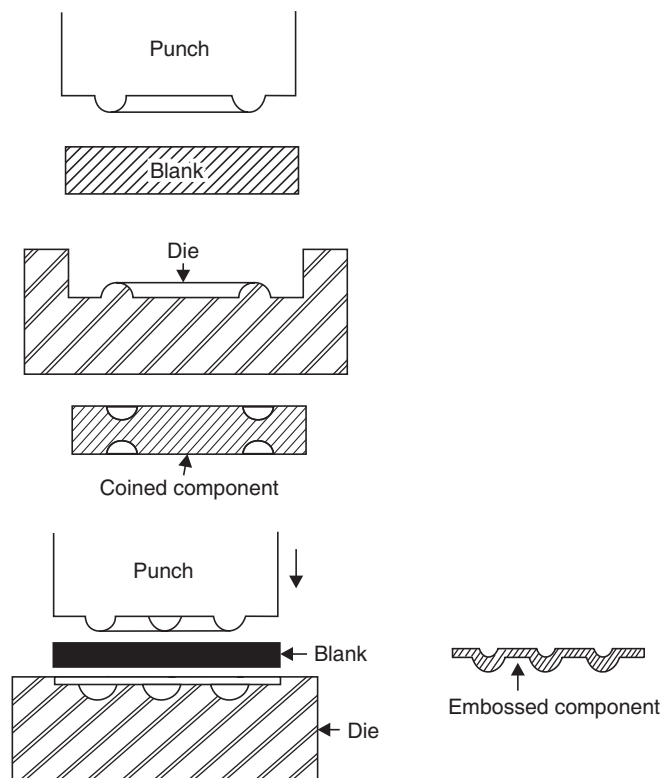

Fig. 5.5 Coining and embossing operations

free to flow upwards (as a result of which it fills up the depressions in the upper die) and downwards (when it fills up depressions in the bottom die). The result of the coining operation is that the design engraved on the top and bottom dies gets imprinted on the corresponding faces of the blank in relief (*i.e.*, raised material) without the size of the blank-circumference changing. Coins used as money in daily usage are manufactured in this manner. Here forces required are much higher, enough to cause plastic-flow of material. The embossing and coining processes are illustrated in Fig. 5.5.

GUILLOTINE SHEAR

Readers may have noticed, that for all press work, the raw material is in the form of sheets or plates. Commercially, sheets and plates are available in sizes 2500×1000 mm or 2500×1250 mm. They have to be cut in smaller rectangular or square pieces, as per sizes required before other operations like, bending, punching etc. are performed. For cutting sheets into smaller pieces with straight cuts, guillotine shears, (which are also mechanical presses) are used.

Guillotine shears are provided with two straight blades of adequate length made of die steel. The blades are hardened and finished by grinding to give smooth and sharp edges. One blade is fixed to the ram (which is much longer in case of guillotine shear), while the other one is fixed to the edge of machine bed in the manner shown in Fig. 5.6.

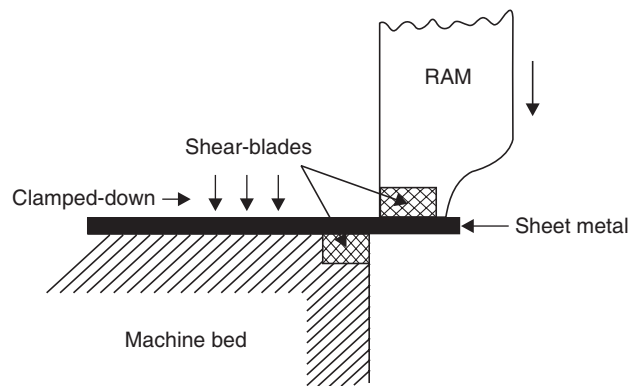

Fig. 5.6 Guillotine shear

The sheet is placed on machine bed with one end projecting. It is held down by clamp. When the ram moves down, the blades shear the sheet along the blade length. Steel plates up to 10 mm thick can be sheared in this way on 250 tonne presses. No sheet-metal shop is complete without a guillotine shear.

QUESTIONS

1. Explain the mechanics of shearing of sheet-metals.
2. Draw the sketch of a die and punch assembly. What is the function of stripper plate ?
3. Bring out the difference between punching and blanking.
4. Describe the deep-drawing process. What defects can occur in a improperly deep drawn product ?
5. Write a brief note on “bending” of sheet metal. What kind of machines are used for this process ? What is spring back and how is its effect eliminated ?

Casting Process

INTRODUCTION

Manufacture of a machine part by heating a metal or alloy above its melting point and pouring the liquid metal/alloy in a cavity approximately of same shape and size as the machine part is called casting process. After the liquid metal cools and solidifies, it acquires the shape and size of the cavity and resembles the finished product required. The department of the workshop, where castings are made is called foundry.

The manufacture of a casting requires:

- (a) Preparation of a pattern,
- (b) Preparation of a mould with the help of the pattern,
- (c) Melting of metal or alloy in a furnace,
- (d) Pouring of molten metal into mould cavity,
- (e) Breaking the mould to retrieve the casting,
- (f) Cleaning the casting and cutting off risers, runners etc., (this operation is called 'fettling'),
and
- (g) Inspection of casting.

Castings are made in a large number of metals and alloys, both ferrous and non-ferrous. Grey cast iron components are very common; steel castings are stronger and are used for components subject to higher stresses. Bronze and brass castings are used on ships and in marine environment, where ferrous items will be subjected to heavy corrosion. Aluminium and aluminium-magnesium castings are used in automobiles. Stainless steel castings are used for making cutlery items.

Casting is an economical way of producing components of required shape either in small lots or in larger lots. However, castings are less strong as compared to wrought components produced by processes such as forging etc. However castings offer the possibility of having slightly improved properties in certain part of the casting by techniques such as use of chill etc. In casting process, very little metal is wasted.

PATTERNS

Patterns are replicas of the casting required. It is similar in shape and size to the final product, but not exactly. Usually, the mould is prepared in wet sand, to which some binder is added to hold sand particles together. The pattern is then withdrawn from inside the sand mould in such a manner that the impression/cavity made in the mould is not damaged or broken in anyway. Finally molten metal is poured into this cavity and allowed to solidify and cool down to room temperature.

PATTERN ALLOWANCES

Since most metals shrink in volume, when solidifying from liquid state and again on cooling, it is obvious, that the pattern should be made slightly larger than the size of finished casting. This difference in size of the pattern is called shrinkage allowance. For cast iron, this allowance is 1% and for aluminium, it is about 1.6%.

On many occasions, castings produced in the foundry shop are machined subsequently. The object of machining is to get exact sizes and better surface finish on the component. If such is the case, a layer of 1.5–2.5 mm thick material has to be provided all round the casting. This is done by making the pattern suitably bigger than the casting. This increase in size of pattern is called “machining allowance”.

Another important allowance provided on patterns is called draft allowance. It facilitates withdrawal of pattern from the mould. It is provided on vertical surfaces. The idea is to give an inclination of 2–3 degrees to vertical surfaces, so that while lifting the pattern, the upper surface is wider and withdrawing the pattern with draft provided will not damage the sand mould. On inner vertical surfaces, draft is provided in such a way that top surface is narrower and bottom portion of pattern is wider.

Apart from the above allowances, some other allowances are sometimes given to compensate for inherent distortion or bending of castings. Sharp corners and bends are also radiusized while making a pattern.

Patterns are usually made of good quality wood. Wood is easy to work, acquires good smooth surface and properly seasoned wood retains its size. It is also relatively cheap and abundant. However, if a very large number of castings are required, metal patterns may be used. Usually, they are made of aluminium-magnesium alloys.

TYPES OF PATTERNS

(i) **Solid or single piece pattern:** Such patterns are made in one piece and are suitable only for very simple castings. There is no provision for runners and risers etc. Moulding can be done either in the foundry floor (called pit moulding) or in a moulding box. There is no difficulty in withdrawing the pattern from the mould as the broadest portion of the pattern is at the top. As an example, if a cylindrical pin with a circular head has to be cast, a one piece pattern shown in Fig. 6.1 will be adequate.

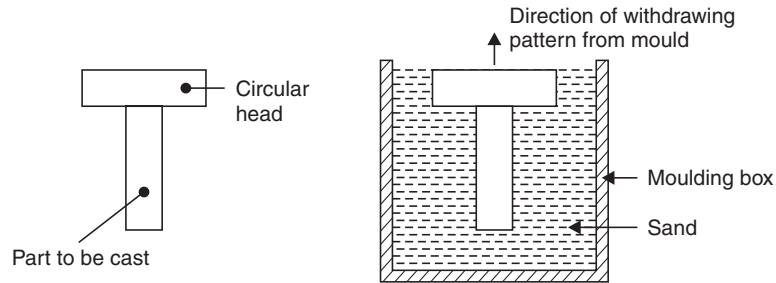

Fig. 6.1

(ii) **Split pattern:** It is not practical to have one piece pattern for parts of complicated shapes, because it would not be possible to withdraw the pattern from the mould. For example, if a circular head was added to the bottom of the pin shown in Fig. 6.1, it would make it necessary to go in for a split pattern as shown in Fig. 6.2.

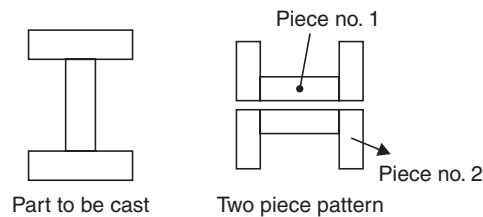

Fig. 6.2

One-half of the impression in the mould will be made by using piece no. 1 in one moulding box and the other half of the impression will be made by using piece no. 2 in a second moulding box. After withdrawing the pattern halves from the respective moulding boxes, the two boxes will be assembled and clamped together, so that the complete impression is available for pouring the metal.

The two pattern halves are provided with locating dowels, so that one-half may sit on the other half in the exact position required with no mismatch. Also two tapped holes are provided on the flat mating surface of each part. These tapped holes are used to provide a grip to lift the pattern halves from the sand without damaging the mould-impression.

The line along which the pattern is divided into halves is called “parting line” and it usually follows the broadest cross-section of the casting. Deciding where the parting line should be is a matter of considerable skill and experience.

Some of the more complicated castings may require pattern to be split in three or even more pieces.

(iii) **Loose piece pattern:** In some cases, the casting may have small projections or overhanging portions. These projections make it difficult to withdraw the pattern from the mould. Therefore these projections are made as loose pieces. They are loosely attached to the main part of the pattern and the mould is made in the usual way.

When the main pattern is withdrawn from the mould, the loose pieces slip off and remain behind in the mould. After removing the main body of the pattern, the loose pieces are taken out by first

moving them laterally and then lifting them through the space vacated by the main pattern. The method is illustrated in Fig. 6.3.

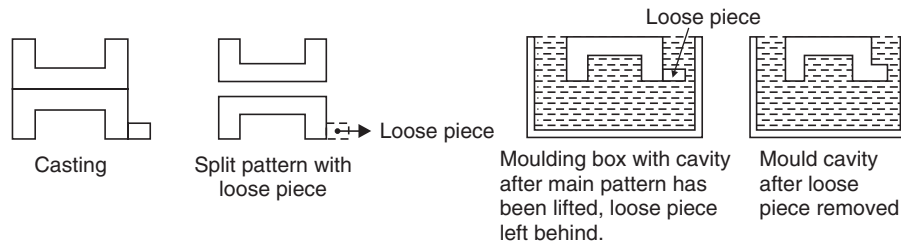

Fig. 6.3

(iv) **Match plate pattern:** Match plate is a metal plate, usually made of aluminium. The two halves of the split pattern are mounted on this match plate one on either side. While fixing them to the match plate, care is taken so that there is no mismatch. These patterns are used in conjunction with mechanically operated moulding machines. Bottom side of match plate pattern is used for making the bottom half of the mould impression in one moulding box (known as the drag). The upper side of the match plate pattern is used for making the mould impression in another moulding box. Finally, the two moulding boxes are kept on top of each other, the bottom box is known as the drag, whereas the top one is called the cope.

(v) **Gated patterns:** Sometimes along with the pattern for the casting, another portion is added so that when the impression is made in the moulding box, the cavity contains a shallow channel along with the main cavity for the object to be cast. This channel will be used for feeding molten metal into the main cavity and is known as the “gate”. Such patterns where provision for gating has been made are called gated patterns. It removes the necessity of making a gate separately.

(vi) Other pattern types include skeleton pattern, sweep pattern and segmental pattern etc. In these patterns, the full pattern is not made and the mould is completed with an improvised pattern. This is done to reduce the cost of pattern making. This procedure is resorted to, if only one or two moulds are to be made.

MOULDING SAND AND ITS PROPERTIES

In foundries, sand is used for making moulds. Natural sand found on the bed and banks of rivers provides an abundant source, although high quality silica sand is also mined. Sand is chemically SiO_2 silicon dioxide in granular form. Ordinary river sand contains a contain percentage of clay, moisture, non-metallic impurities and traces of magnesium and calcium salts besides silica grains. This sand, after suitable treatment, is used for mould making. A good, well prepared moulding sand should have the following properties:

- Refractoriness *i.e.*, it should be able to with stand high temperatures.
- Permeability *i.e.*, ability to allow gases, water vapour and air to pass through it.
- Green sand strength *i.e.*, when a mould is made with moist sand, it should have sufficient strength, otherwise mould will break.

(iv) Good flowability *i.e.*, when it is packed around a pattern in a moulding box, it should be able to fill all nooks and corners, otherwise the impression of pattern in mould would not be sharp and clear.

(v) Good collapsibility *i.e.*, it should collapse easily after the casting has cooled down and has been extracted after breaking the mould. It is particularly important in case of core making.

(vi) Cohesiveness *i.e.*, ability of sand grains to stick together. Without cohesiveness, the moulds will lack strength.

(vii) Adhesiveness *i.e.*, ability of sand to stick to other bodies. If the moulding sand does not stick to the walls of moulding box, the whole mould will slip through the box.

Properties like permeability, cohesiveness and green strength are dependent upon size and shape of sand grains, as also upon the binding material and moisture content present in sand. Clay is a natural binder. Chemical binders like bentonite are sometimes added if clay content in natural sand is not enough.

Standard tests have been devised by foundry men to determine properties of sand. Generally fresh moulding sand prepared in the foundry has the following composition:

Silica	75% (approx.)
Clay	10–15%
Bentonite	2–5% (as required)
Coal dust	5–10%
Moisture	6–8%

Core sand has oil as the main binding material. A core gets surrounded by molten metal which causes the oil to vaporise. This increases collapsibility of sand and makes it easy to remove sand from the holes in the casting.

MOULD MAKING TECHNIQUE

Mould making is a very skilled operation. We shall describe, step by step, the procedure for making a mould for a split pattern.

Step 1: Place bottom half of the split pattern on a flat moulding board, with the parting surface face downwards. Sprinkle some parting sand on the pattern and the moulding board. Parting sand is silica sand without any clay or binding material. Then place a moulding box to enclose the pattern.

Step 2: Spread facing sand to cover all parts of the pattern up to a depth of 20–25 mm. Facing sand is freshly prepared moulding sand. Fill up the remaining space left in the moulding box with backing sand. Backing sand is prepared by reconditioning the previously used foundry sand which is always available on the foundry floor. Use of backing sand reduces the requirement of facing sand, which is quite costly.

Step 3: Next, the sand in the moulding box is rammed with a special tool. Ramming means pressing the sand down by giving it gentle blows. Sand should be packed in the moulding box tightly but not too tightly. If as a result of ramming, the level of sand goes down in the box, more sand should be filled in and rammed. Then with a trowel, level the sand lying on the top of the mould box. Next take a venting tool (it is a long thick needle), make venting holes in the sand taking care that they are not so deep as to touch the pattern. This moulding box will form the lower box, and is called “drag”.

Step 4: Now turn over the moulding box gently and let it rest on some loose sand after levelling the foundry floor. Place the top half of split pattern in correct relative position on the flat surface of the bottom half of the pattern. Place another empty moulding box on the top of first moulding box (*i.e.*, drag) and clamp them temporarily. Sprinkle some parting sand upon the exposed surface of the top half of pattern and the surrounding sand. Cover the pattern in 20–25 mm deep facing sand. Place two taper pins at suitable places, where runner and riser are to be located. Full up the box with backing sand, pack in sand with ramming tool, level sand and make venting holes. Remove taper pins and make room on foundry floor, next to the drag box, for keeping the “cope” as the top box is called. Unclamp the moulding boxes, lift ‘cope’ and place it down on its back. Now the flat parting surface of both parts of the split pattern can be seen one in each box.

Step 5: In order to lift the patterns from cope and the drag, locate the tepped holes on the flat surface and screw in a lifting rod in these holes. This provides a handle with which the patterns can be easily lifted up vertically. However first the patterns are loosened a bit by rapping these handles gently before lifting them. This minimises the damage to sand moulds.

Step 6: After removing wooden pattern halves, the mould cavities may be repaired in case any corners etc., have been damaged. This is a delicate operation. Also, if any sand has fallen into the mould cavity, it is carefully lifted or blown away by a stream of air.

Step 7: In case, any cores are used to make holes in the casting, this is time for placing the cores in the mould cavity. Of course, the cores are supported properly by means of core prints or other devices like chaplets etc. Lack of adequate support for cores may result in their displacement from correct position when the liquid metal is poured in.

Step 8: Before closing of the mould boxes, graphite powder is sprinkled on the mould surface in both boxes. In the drag box, a gate is cut below the location of the runner (in the cope box). The molten metal poured in the runner will flow through the gate into the mould cavity.

In case, the moulds have been dried, instead of graphite powder, a mould wash containing suspension of graphite in water is lightly spread over the mould surface.

After all these operations are complete, the cope box is again placed on the drag and clamped securely. Now the mould is ready for pouring molten metal. Molten metal is poured until it shows up in the riser. It ensures that mould cavities are full of metal and that it will not run short. A complete mould ready for pouring is shown in Fig. 6.4. Sand moulds are of three kinds:

(a) **Green sand mould:** In such moulds, pouring of molten metal is done, when the sand is still moist.

(b) **Skin dry moulds:** Such moulds are superficially dried by moving a flame over mould cavity so that mould dries only up to a depth of few mm.

(c) **Dry moulds:** After preparing such moulds, they are dried by keeping the mould for 24–36 hours in an oven whose temperature is maintained at 130–150°C. Dry sand moulds are stronger and cannot give rise to any moisture related defects in the casting. Mould wash improves the surface finish of castings.

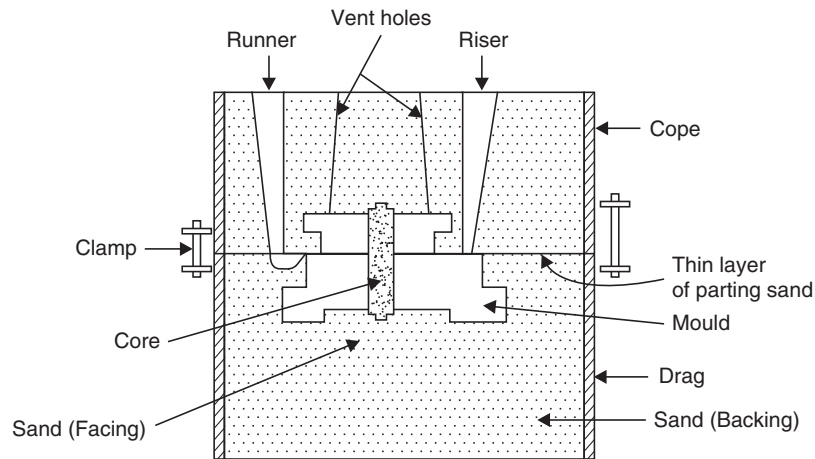

Fig. 6.4 A mould ready for pouring

CORES

Whenever a hole, recess, undercut or internal cavity is required in a casting, a core, which is usually made up of a refractory material like sand is inserted at the required location in the mould cavity before finally closing the mould.

A core, being surrounded on all sides by molten metal, should be able to withstand high temperature. It should also be adequately supported otherwise due to buoyancy of molten metal, it will get displaced. When the molten metal around the core solidifies and shrinks, the core should give way, otherwise the casting may crack (hot tear). Cores, as explained previously, should be made of oil sand and dried in ovens before use.

Cores are made with the help of core boxes. Core boxes are made of wood and have a cavity cut in them, which is the shape and size of the core. The sand is mixed and filled in the core boxes. It is then rammed. A core box is made in two halves, each half contains half impression of core. Sometimes a core may need reinforcements to hold it together. The reinforcements are in the shape of wire or nails, which can be extracted from the hole in the casting along with core sand.

CORE PRINTS

A core must be supported in the mould cavity. Wherever possible, this is done by providing core prints. Core prints are extensions of the core which rest in similar extensions of the mould cavity so that core remains supported in the mould cavity without the core falling to the bottom of the cavity. For example, if the pin with collars shown in Fig. 6.5 had a central hole, the hole could be produced by inserting a core in mould cavity as shown in Fig. 6.5.

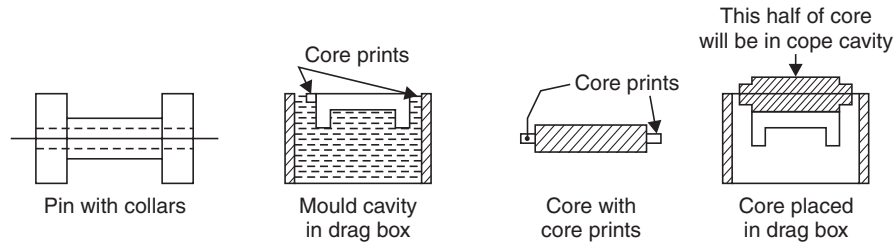

Fig. 6.5

Another device to support cores is “chaplets”. These are clips made of thin sheets of the same metal as the casting. These clips are used to support the weight of cores. When the molten metal is poured, chaplets melt and merge into the molten metal.

GATES, RUNNERS AND RISERS

The passage provided in the mould through which molten metal will flow into the mould cavity is known as the gating system. It is provided by scooping out sand in the drag box to cut necessary channels.

The top of the runner hole in the cope is widened into a pouring basin. The molten metal then flows down through the runner into a well from where it enters the gating system and into the mould cavity. At a suitable location in the mould cavity the riser hole is connected.

Without a gate, the metal would have fallen straight into the mould cavity damaging it. Besides, the gating system is so designed as to trap impurities from entering into mould cavity. The function of the riser is two fold. Firstly, it provides a visible indicator that the mould cavity is full. Secondly and more importantly, the molten metal in the riser provides a reservoir to feed the shrinkage caused as the casting progressively solidifies and cools. It is desirable that the metal in the riser remains molten as long as possible. This is done by providing a “hot-top”.

Sometimes, the riser does not open out to the top surface of the cope box, it is then called a blind riser. In that case, its sole function is to feed the shrinkage associated with solidification of molten metal.

The various terms associated with gating system will be clear by studying the gating system shown in Fig. 6.6.

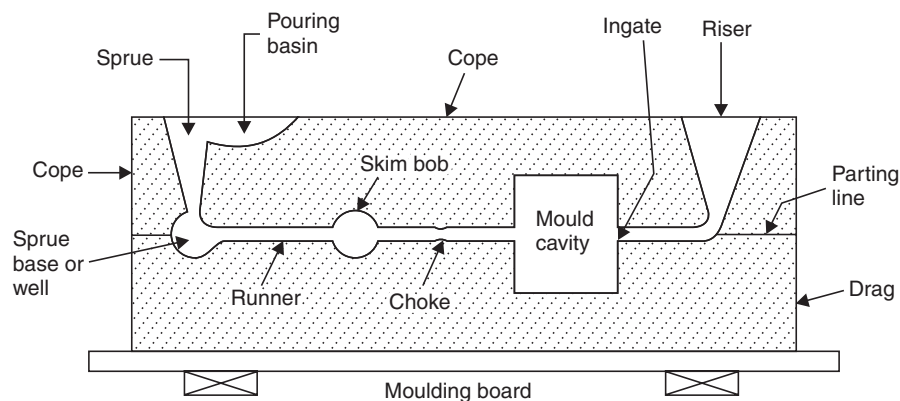

Fig. 6.6 Gating system

CUPOLA

For casting, metal has to be heated above its melting point. The heating is done in a furnace. Depending upon the fuel used, the furnaces may be classified as electric, oil fired or coal fired etc. Where metal free from any impurities is required, electric furnaces are used. In oil fired and coal fired furnaces, the flame plays upon the hot metal and the molten metal picks up impurities by coming in contact with flames. Electric furnaces are costly and equally costly to operate.

Usually, for non-ferrous metals and alloys, oil fired crucible furnaces are used. The metal is placed in large graphite crucibles and heated on the outside surface of crucibles, so that flames do not come in actual contact with metal.

CONSTRUCTION

For melting cast iron, a cupola furnace is used. It is one of the most economical and convenient ways of providing a supply of molten cast iron. Cupola uses coke as fuel. Coke is produced by heating ordinary steam coal in an inert atmosphere. It gives more intense heat than coal.

Cupola consists of a long cylindrical steel shell with its interior lined with refractory fire-bricks. It is erected vertically up and rests on short pillars about 0.85 metres above the ground level. The bottom of the cupola is provided with steel doors which are also lined with fire resistant material and covered with a layer of good quality sand.

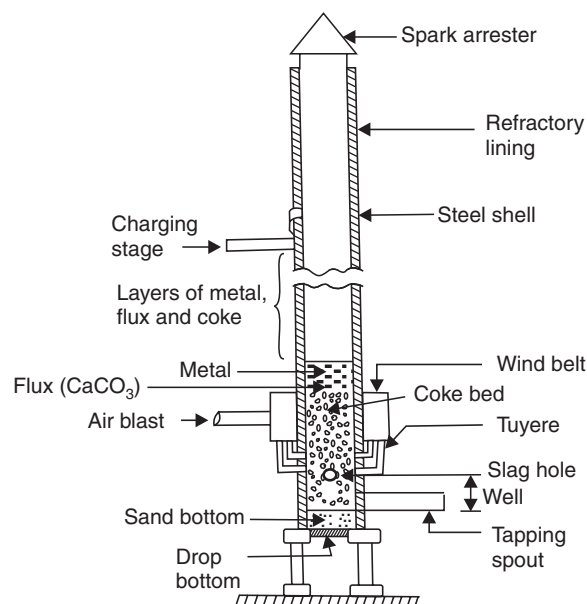

Fig. 6.7 Cupola

At a suitable height, near the top of this steel shell, an opening is cut, which is used for charging fuel and raw materials into the furnace. A wind box, connected to a motorised blower is provided at a height of one meter or so above the bottom closing doors. From this wind box, small air passages are

provided into the cupola shell for supply of air to aid combustion of fuel. These air passages are called tuyeres. At the bottom, above the door, a tapping spout is provided to tap molten metal and about 350 mm above the tapping hole another hole called the slag hole is provided at the back of the cupola, through which liquid slag can be forced out under air pressure.

The cylindrical space provided between the tap hole and the slag hole is called the molten metal well in which the molten metal accumulates between two-taps. All these features are depicted in Fig. 6.7.

OPERATION OF CUPOLA

In the cupola the first operation is to repair the lining of the door and area around it and then closing the hinged doors. Doors are jammed shut, so that there is no possibility of their opening while the cupola is in operation. Then fire is lighted at the bottom with the help of some wood and kerosene oil rags. When the fire is burning strongly, coke is added from the top charging door until the height of coke bed reaches about half a metre above tuyeres. After that tuyeres are opened partially, air blower is switched on and alternate layers of metal, flux (in the form of limestone pieces) and coke are charged from the top. These alternate layers settle down on coke bed. When the cupola is filled up to the level of charging door, the tuyeres are opened fully and the heating of charge begins. The coke near the tuyeres start burning and the coke bed becomes intensely hot. The metal in lower layers near the coke bed starts melting. Lime stone breaks down to CaO and CO_2 . The calcium oxide reacts with impurities like silica and other oxides forming slag (CaSiO_3). Slag is lighter and floats upon the molten metal layer. Ultimately, when enough metal has melted, the slag is blown out by opening the slag hole. The metal is then tapped by puncturing the tap hole with a long steel rod with one end shaped like a cone. The molten metal will start flowing into the metal chute and is collected into ladles (refractory lined steel buckets to which long handles are welded) and taken away for pouring into moulds. The tap hole is then closed by plugging it with a lump of fire clay.

The properties of cast iron improve with addition of small amounts of ferro manganese and ferro silicon. Since most of the manganese and silicon already present in scrap cast iron, pig iron and a little bit of thin steel scrap, which forms the metallic charge dropped into cupola, is oxidised and lost, addition of ferro manganese and ferro silicon has to be done to the molten metal in the ladles before pouring.

After the day's work is over, extra coke is charged into the cupola along with last charge. After all the metal has melted, the air blower is switched off and the bottom door of cupola is opened. Whatever unburnt coke etc., is left, is allowed to fall to the ground beneath the cupola door. This is necessary otherwise the left over coke, slag and metal etc., may join up in one mass, then its removal will become extremely difficult. The size of a cupola is denoted by its internal diameter.

CASTING DEFECTS

Some of the common defects in the castings are described below:

1. **Blow-holes:** They appear as small holes in the casting. They may be open to surface or they may be below the surface of the casting. They are caused due to entrapped bubbles of gases. They may

be caused by excessively hard ramming, improper venting, excessive moisture or lack of permeability in the sand.

2. **Shrinkage cavity:** Sometimes due to faulty design of casting consisting of very thick and thin sections, a shrinkage cavity may be caused at the junction of such sections. Shrinkage cavity is totally internal. It is illustrated in Fig. 6.8.

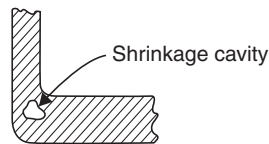

Fig. 6.8

It is caused due to shrinkage of molten metal. Remedy is to use either a chill or relocation of risers.

3. **Misrun:** This denotes incomplete filling of mould cavity. It may be caused by bleeding of molten metal at the parting of cope and drag, inadequate metal supply or improper design of gating.

4. **Cold shut:** A cold shut is formed within a casting, when molten metal from two different streams meets without complete fusion. Low pouring temperature may be the primary cause of this defect.

5. **Mismatch:** This defect takes place when the mould impression in the cope and drag do not sit exactly on one another but are shifted a little bit. This happens due to mismatch of the split pattern (dowel pin may have become loose) or due to defective clamping of cope and drag boxes.

6. **Drop:** This happens when a portion of the mould sand falls into the molten metal. Loose sand inadequately rammed or lack of binder may cause this defect.

7. **Scab:** This defect occurs when a portion of the face of a mould lifts or breaks down and the recess is filled up by molten metal.

8. **Hot tear:** These cracks are caused in thin long sections of the casting, if the part of the casting cannot shrink freely on cooling due to intervening sand being too tightly packed, offers resistance to such shrinking. The tear or crack usually takes place when the part is red hot and has not developed full strength, hence the defect is called "hot tear". Reason may be excessively tight ramming of sand.

9. Other defects include scars, blisters, sponginess (due to a mass of pin holes at one location) and slag inclusions etc.

DIE CASTING

A sand mould is usable for production of only one casting. It cannot be used twice. Die is essentially a metal mould and can be used again and again. A die is usually made in two portions. One portion is fixed and the other is movable. Together, they contain the mould cavity in all its details. After clamping or locking the two halves of the dies together molten metal is introduced into the dies. If the molten metal is fed by gravity into the dies, the process is known as gravity die casting process. On the otherhand, if

the metal is forced into the dies under pressure (*e.g.*, a piston in a cylinder pushes the material through cylinder nozzle), the process is called “pressure die casting”.

The material of which the dies are made, should have a melting point much higher than the melting point of casting material. A great number of die castings are made of alloys of zinc, tin and lead, and of alloys of aluminium, magnesium and copper. Hence dies are made out of medium carbon low alloy steels. The dies are usually water or air blast cooled.

Since most materials contract on cooling, extraction of castings from dies becomes important otherwise they will get entangled in the die as they cool. Therefore, in the design of dies, some arrangement for extraction of casting is incorporated.

STEPS IN DIE CASTING

1. Close and lock the two halves of a die after coating the mould cavity surfaces with a mould wash, if specified:

2. Inject the molten metal under pressure into the die.
3. Maintain the pressure until metal solidifies.
4. Open die halves.
5. Eject the casting along with runner, riser etc.
6. The above cycle is repeated.

Two pressure die casting methods are used:

1. **Hot chamber process:** This uses pressures up to 35 MPa and is used for zinc, tin, lead, and their alloys. In this process the chamber, in which molten metal is stored before being pressure injected into the die, is kept heated.

2. **Cold chamber process:** In this process, pressures as high as 150 MPa are used. The storing chamber is not heated. This process is used mainly for metals and alloys having relatively higher melting point *e.g.*, aluminium, magnesium and their alloys.

Advantages and disadvantages of die casting:

1. It is used for mass production of castings of small and medium size. *e.g.*, pistons of motorcycle and scooter engines, valve bodies, carburettor housings etc.

2. The initial cost of manufacturing a die is very high. It is a disadvantage.

3. This process produces high quality, defect free castings.

4. The castings produced by this process are of good surface finish and have good dimensional control and may not require much machining. All castings produced are identical.

5. Large size castings cannot be produced by this process. It is a disadvantage.

6. Castings with very complex shapes or with many cores are difficult to produce by die casting.

7. In case of mass production, castings can be produced cheaply.

8. The process does not require use of sand and requires much less space as compared to a conventional foundry using sand moulds.

QUESTIONS

1. What is a pattern? Name the various allowances associated with patterns and why are they provided?
2. Describe, stepwise, the procedure of making a mould with a two piece split pattern.
3. What are the requisite properties in a good foundry sand?
4. Make properly labelled sketch of a cupola and write a brief account of its operation.
5. Enumerate some common casting defects and explain the reasons which cause these defects.

Objective Type Questions

UNIT II METAL FORMING AND CASTING PROCESS

Pick out the most appropriate option:

1. Advantage of cold working is
(a) better dimensional accuracy (b) better surface finish
(c) higher strength (d) all of these.
2. Typical hot working temperature range for steel is
(a) 650–1050°C (b) 650–723°C
(c) 500–910°C (d) none of these.
3. The forging operation of “upsetting” is
(a) reverse of drawing down process (b) it is a bending operation
(c) it is a drifting operation (d) none of these.
4. “Alligatoring” is a defect associated with
(a) forging process (b) casting process
(c) extrusion process (d) rolling process.
5. A “die” is used in
(a) casting process (b) extrusion process
(c) forging process (d) all of these.
6. Out of the following, which is the defect which is not associated with casting process:
(a) Blow holes (b) Scale
(c) Centre burst (d) Hot tear.
7. Which “term” is not associated with casting process?
(a) Gate (b) Runner
(c) Riser (d) Swage.

8. Fuel used in a cupola consists of
(a) steam coal (b) furnace oil
(c) electricity (d) hard coke.
9. Which allowance is not provided on the “pattern” made for a casting ?
(a) Machining allowance (b) Solidification allowance
(c) Draft allowance (d) Shrinkage allowance.
10. “Blanking” is an expression used in
(a) sheet metal work (b) casting process
(c) drawing (d) rolling.

Indicate, if following statements are True or False:

11. In forward extrusion process, there is higher material or scrap waste than in backward extrusion process.
12. Mechanical working processes result information of grain-flow lines which reduces the strength of parts.
13. The advantage of a three high mill is to avoid the necessity of transporting the material being rolled from one side of rolls to another after one pass is over.
14. “Blow hole” and shrinkage cavities occur in castings. The factors which cause these defects are similar in nature.
15. Sand mould is an example of permanent mould.
16. Mismatch is shift of the individual parts of a casting with respect to each other.
17. In cold rolling process, crystal structure is refined.
18. Hooker extrusion is a cold extrusion process.
19. The object of “in process annealing” is to reduce to hardness of the wire being drawn in wire drawing process.
20. The permeability of fine grained moulding sand will be more.

ANSWERS

- | | | | | |
|--------|--------|--------|--------|---------|
| 1. (d) | 2. (a) | 3. (a) | 4. (d) | 5. (d) |
| 6. (c) | 7. (d) | 8. (d) | 9. (b) | 10. (a) |
| 11. T | 12. F | 13. T | 14. F | 15. F |
| 16. T | 17. F | 18. T | 19. T | 20. F |

**This page
intentionally left
blank**

UNIT III

Introduction to Machining and Its Applications

**This page
intentionally left
blank**

Lathe

INTRODUCTION

In previous chapters, we have seen that with the help of forging and casting processes, we can manufacture machine parts of different shapes and sizes. However, parts so manufactured have poor geometry and size control (*i.e.*, tolerance on dimensions) and their surface finish is not very good. Hence, in most cases, castings and forgings undergo machining before these parts can be assembled with other parts to form a complete machine like cycle or motor car etc.

In machining, we use a machine tool like lathe or shaper and a cutting tool made of a much harder material than the material of the part to be machined. Material removed from the part is achieved by the relative movement between the cutting tool and the part. The cutting tool is given a sharp cutting edge and it is forced to penetrate inside the work piece surface to a small depth. The relative motion between the tool and work piece results in a thin strip of material being sheared off from the work piece reducing the thickness of the work piece. This process has to be repeated several times before the entire surface of the work piece can be covered and reduced in depth. The thin strip of the material sheared from the work piece is called 'chip'. It must be understood that chips are produced by shearing action and not by cutting. Substantial amount of power is required for machining. The function of the machine tool is to provide this power and the required motion of work piece relative to the tool.

In some cases of machining, motion is given to the work piece and tool remains stationary. In some other cases, the work piece is stationary and the machine tool provides motion to the cutting tool. In yet other cases, motion is given both to tool as well as the work piece.

Cutting tools are made of material which can be hardened by suitable heat treatment. During machining, lot of heat is generated and the temperature of the cutting edge of the tool may reach 650–700°C. The tool must maintain its hardness even at such elevated temperatures. This property of retaining its hardness at elevated temperatures is called 'red hardness'. Cutting tools develop the property of red-hardness due to addition of tungsten and molybdenum to high carbon steel. These days, cutting tools are made of high speed steel, or tungsten carbide. Tools made of ceramic materials (like Al_2O_3 , SiC), and polycrystalline diamonds are also used for special applications.

Cutting speed: Readers must understand the concept of "cutting speed". Cutting speed means the linear speed at which cutting takes place. If the tool is stationary, the speed at which the work material approaches the cutting edge of tool is the cutting speed. It is measured in metres per minute.

The optimum cutting speed depends upon the tool material, the material to be cut and whether a cutting fluid is being used or not. The purpose of using cutting fluid is to remove heat from the cutting area and to lubricate the tool face so that the friction between chip and tool surface reduces. Use of cutting fluid makes cutting process more efficient. Similarly, cutting at recommended cutting speed results in improved tool life and performance.

Recommended cutting speed for machining cast iron and mild steel with high speed tools is 35 metres per minute. However, if tungsten carbide tools are used, cutting speeds of 65–70 metres per minute may be used. For non-ferrous material, much higher cutting speeds are permissible.

CENTRE LATHE

A centre lathe is also called an engine lathe or simply a lathe. It is one of the commonest and oldest machine tools. It is also one of the most versatile and widely used machines. Its main function is production of cylindrical profiles.

A centre lathe is shown in Fig. 1.1.

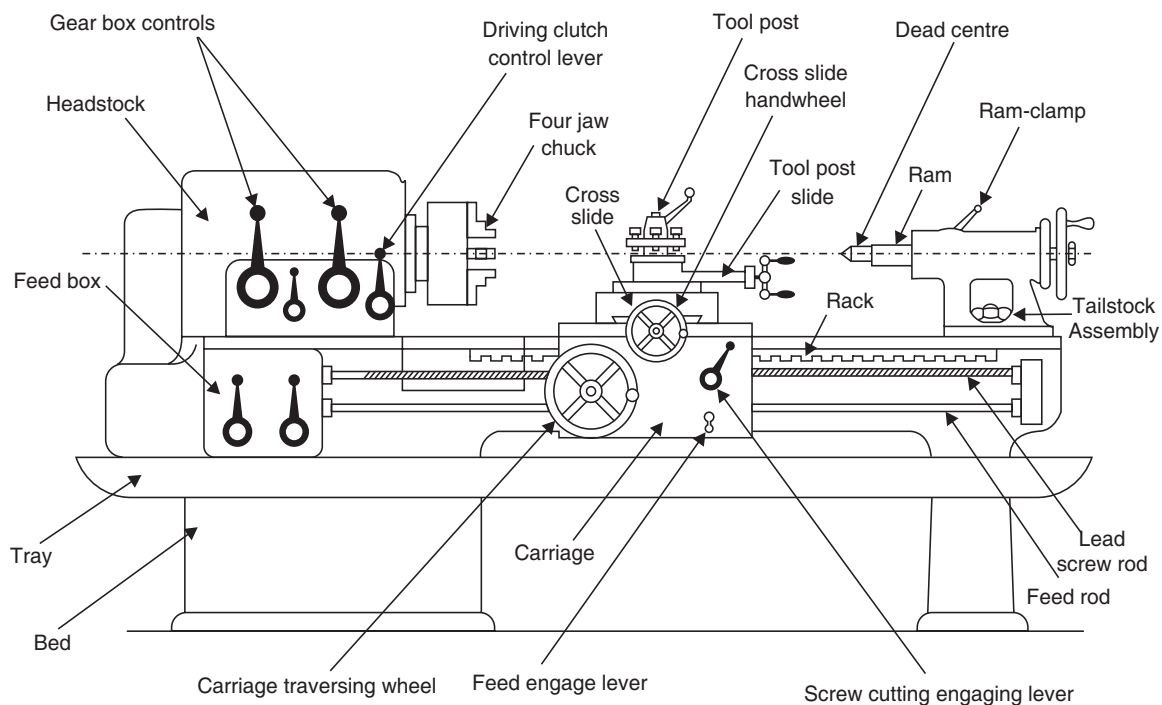

Fig. 1.1 Centre lathe

The main parts of a centre lathe are:

1. **Machine bed**, usually made of cast iron. It holds or supports all other parts of the lathe. The top of the machine bed is flat and is machined to form guide ways on which the carriage slides along the length of the lathe.

2. **Headstock:** It is fixed at the extreme left hand of the bed and contains shafts and gears immersed in lubricating oil. The driving shaft inside is driven by an electric motor. The driven shaft, which is in the form of a hollow spindle can be driven at various r.p.m. by changing gears, projects out of the headstock, A chuck (either three jaw or four jaw), is screwed on this spindle. The work piece can be held in the jaws of the chuck. When the spindle rotates, the chuck as well as the work piece held also rotate about the longitudinal axis of the spindle.

3. **Tailstock:** A tailstock is provided at the right hand end of the bed. It can slide along the guide ways provided on the bed and may be brought nearer to the headstock, if so desired. It can then be clamped or fixed on the bed in that position.

The tailstock has a spindle in the upper part of the tailstock, the axis of which coincides with the axis of the headstock spindle, both being at the same height above the bed. This spindle can be moved forwards or backwards by rotating a hand wheel. The front portion of tailstock spindle carries a 'dead' or 'live' centre. When a long work piece is held in the chuck at the headstock end, it is supported at the tailstock end by moving forward the tailstock spindle. Of course, there has to be a small conical hole in the centre of the work piece, in which the tailstock centre may be inserted to provide support. If the centre (being carried in its own bearings) rotates along with the work piece, it is called a live centre. However, if the tailstock centre remains stationary and work piece alone rotates, the centre is called 'dead centre' and the conical tip of centre has to be lubricated with grease to reduce the friction between the tailstock centre and the work piece.

A typical tailstock is shown in Fig. 1.2.

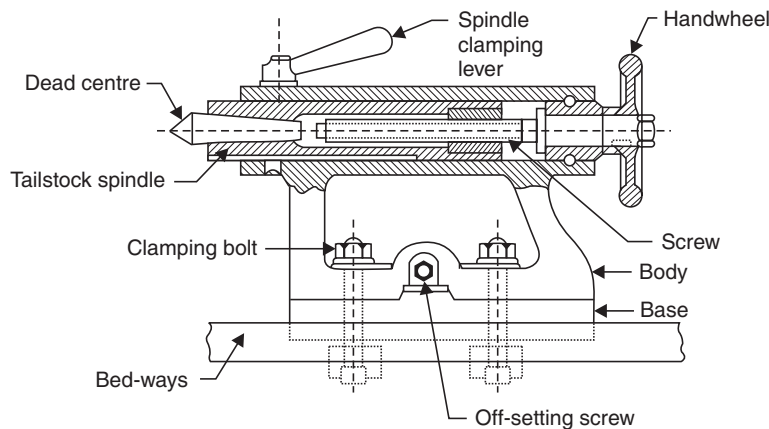

Fig. 1.2 Tailstock

4. **Carriage:** A carriage is shown in Fig. 1.3. The carriage can slide along the length of the machine bed from the tailstock end to the head stock end. This movement is controlled by manually operating the hand traversing wheel. It can also be imparted this traversing motion at different speeds automatically by engaging into the feed rod or feed shaft.

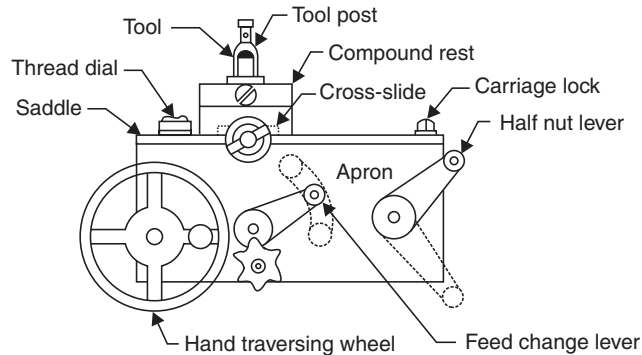

Fig. 1.3 Carriage

The carriage carries a cross slide, which can independently move in a crosswise direction at right angles to the bed. The cross slide can also be moved either manually through a smaller hand wheel or through an automatic device. Mounted upon the cross slide is another small slide, called the compound rest (or tool post slide) which can be rotated in a horizontal plane. Its normal position at 0° rotation is parallel to bed. Its angle of rotation can be read off on a protractor. This compound rest is used during taper turning to set the tool for angular cuts. The compound rest can be moved only manually. The cutting tool is clamped in the tool post which is mounted on top of the compound rest.

The gears, clutches and other mechanism required for giving movement to the carriage and cross slide etc. is hidden from view by means of an apron (thin steel plate) screwed upon the front face of the carriage. Half hidden in the front are two long shafts, (the screwed one is called the lead screw shaft/rod and the plain one is called feed shaft/rod) extending from the headstock to the tailstock end. These two shafts can be engaged one at a time to give longitudinal movement to the carriage. Lead screw is only used during the screw cutting operation. Feed shaft is used in other operations like turning.

Size of a lathe is specified by the distance between headstock chuck to tailstock centre. This is the length of the longest job which can be accommodated or machined on the lathe. In addition the swing of the lathe (*i.e.*, the vertical distance between chuck centre and the lathe bed) is specified as this is the radius of the largest work piece which can be turned on the machine.

CUTTING TOOLS USED ON THE LATHE

In a centre lathe, the work piece is held and fastened in a chuck. If a component is manufactured out of a round bar, the bar passes through the hollow spindle of the headstock, and the required length of bar is pulled out and then clamped in the jaws of the chuck, free end of the bar projecting towards the tailstock end. Mostly the movement of tool is from right to left. This is known as right hand working. Sometimes, it becomes necessary to do some work while moving tools from left to right, *i.e.*, left hand working. The tools for right hand lathe operations are quite different than tools for left hand working. In fact they are mirror images of each other.

Many different kind of operations are carried out on lathes such as

- (i) Turning
- (ii) Facing

- (iii) Taper turning
- (iv) Profile turning or form turning
- (v) Parting
- (vi) Boring
- (vii) Threading
- (viii) Knurling.

The tools used for these operations all different. Some of the right hand tools are shown in Fig. 1.4.

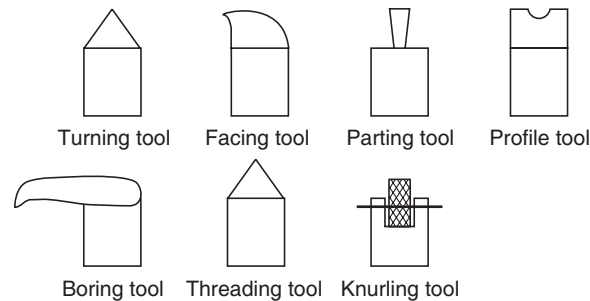

Fig. 1.4 Right hand lathe tools

HOLDING THE WORK PIECE IN THE CHUCK AND CENTERING

All jobs have to be securely clamped in the chuck and centred before any of the above listed operations can be performed on a lathe. 3-jaws chuck is a self centering device and is used for clamping round bars etc. A four jaws chuck is for clamping irregularly shaped jobs. In 4-jaws chuck each jaw moves in radially independent of other jaws. Centering means that the centre line of the work piece should nearly coincide with centre line of machine spindle. It is not enough to hold the job centrally in the chuck, the portion of work piece projecting out of chuck should also be centrally placed. Collet chuck, face plates etc. are some other holding devices for the work piece.

Turning: In this operation, the work piece is rotated at a suitable r.p.m., so that metal cutting may take place at the recommended cutting speed. If ' d ' is the diameter of work piece and N the r.p.m., the cutting speed can be calculated as $\pi.d.N$. A cutting tool is clamped in the tool post taking care that the tip of the tool is at the same height as the centre of job. In the turning operation, the job rotates and the cutting tool is inserted in the surface of work piece by moving the cross slide, starting at the right hand end of the work piece. The depth of cut of 1–1.5 mm may be taken and then the tool is steadily moved from right to left by sliding the carriage on the machine bed. The operation of turning is shown in Fig. 1.5.

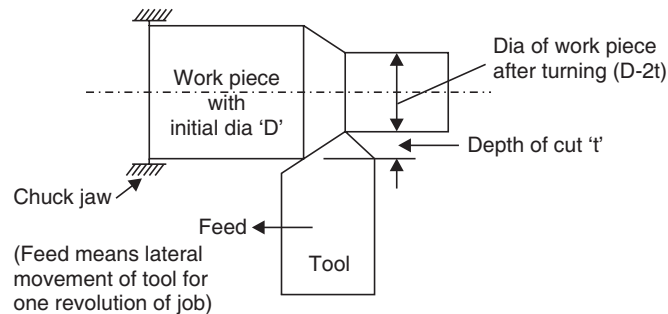

Fig. 1.5 Turning operation

Feed is given to the tool. Feed is measured in mm/rev of work piece. Since work piece r.p.m. is N , feed per minute will be $N \times \text{feed/revolution}$ (mm).

Obviously, it may not be possible to achieve the desired reduction of diameter in one pass of the tool, the tool will have to be brought back to the right side, again advanced by 1–1.5 mm by moving the cross slide and then traversed again from right to left side. This process will have to be repeated several times until the desired diameter is reached.

In the process of turning, a cylindrical shape is generated as a result of the combined movement of the work piece and the tool.

Facing: In this operation, the work piece is rotated as before, but the tool is moved across by cross slide. The carriage remains fixed in one position. The result is production of a flat circular section at one end of the cylinder. All lengths can be measured taking this surface as datum during further machining operations.

TAPER TURNING

Taper turning means production of a conical surface by gradual reduction in diameter as we proceed along the length of the cylinder. A conical surface will be produced, if the cutting tool moves along a line which is inclined to the longitudinal axis of the work piece instead of moving parallel to it. A taper is defined by the half angle (α) of the cone as shown in Fig. 1.6.

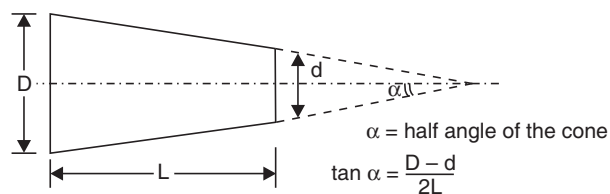

Fig. 1.6 Taper turning calculation

Following methods are used for taper turning on lathe:

1. By swivelling the compound rest.
2. By offsetting tailstock.
3. By using a taper turning attachment.
4. By using a form tool.

Taper turning by swivelling compound rest

In this method the compound rest is swivelled *i.e.*, rotated in a horizontal plane by half cone angle (α). The work piece is rotated as usual, but instead of using the carriage to traverse the tool, the tool is moved forward by the compound rest slide handwheel. Since the compound rest has been swivelled to an inclined position with respect to the longitudinal axis of lathe, the tool moves at an angle to the longitudinal axis of lathe generating a conical surface accurately.

By setting over the tailstock centre:

In this method, the tailstock centre is shifted in a direction at right angles to the longitudinal axis of the machine. The tailstock base guide ways have some clearance and it can be shifted laterally by a limited amount on the machine bed. The calculation of the taper angle can be understood from Fig. 1.7.

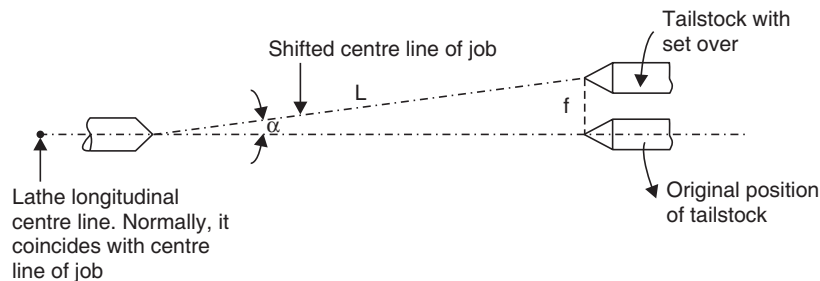

Fig. 1.7 Offsetting tailstock

If length of job is L and set over of tailstock is ' f ' then half taper angle, $\alpha = \sin^{-1} \frac{f}{L}$. It will be appreciated that in this case tool will traverse parallel to machine centre line but the work piece has taken an inclined position with respect to the longitudinal centre line machine. This method can only be used, if taper angle is small. Since the set over cannot be accurately measured, this method is not accurate, but in this case, work pieces with long length can be tackled, which is not possible with compound rest method.

By using taper turning attachment

This method allows accurate production of a wide range of tapers. A taper turning attachment is used on the backside of the cross slide. In this case the cross slide moves a certain distance for a given amount of longitudinal traverse by the carriage. That is the tool gets a simultaneous movement in two perpendicular axes. The angle of taper cut will depend upon the ratio of movement of tool in the two axes.

Taper turning by form tool

In this case, tapers of only very short length are cut. The front profile of the form tool is such that when the tool is pushed against the work piece, the taper is produced. This method is illustrated in Fig. 1.8.

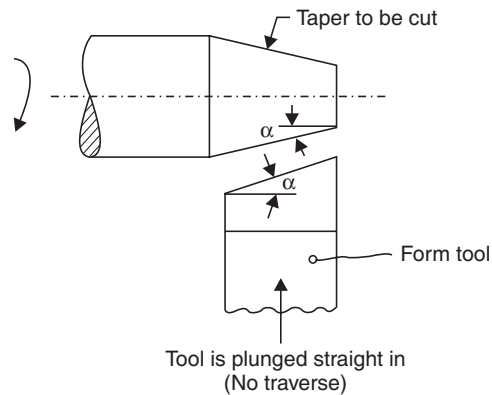

Fig. 1.8 Taper by form tool

PROFILE OR FORM TURNING

The basic principle of this lathe operation has become clear from the example of taper turning with the help of a form tool. Various other forms like a specified radius, semicircular shape etc. can be generated in a similar manner with a suitably shaped form tool and taking a plunge cut (*i.e.*, only cross slide will be used while carriage will remain locked in position).

Form tools should have a short profile, otherwise the work piece and the tool tend to vibrate and chatter.

Parting off: This operation is performed with a parting tool. This also requires a plunge cut. Gradually the diameter of work piece at the tool contact surface will reduce and will become smaller and smaller as the tool is fed in. Ultimately as the tip of tool will reach the centre line of job, the job will be parted in two pieces, the left hand piece will remain clamped in the chuck, while the right hand piece of requisite length will separate out.

Boring: Boring means enlarging an existing hole. For initial drilling of a hole on the lathe machine, tailstock centre is removed and in the tailstock spindle a drill is inserted. The tailstock is brought closer to the work piece, which is held in the chuck and rotated. Now using the handwheel of the tailstock, the drill is advanced.

The advancing drill comes in contact with end face of the work piece and drills a hole through it. After the hole has been drilled to required depth, the drill is withdrawn. This hole can then be enlarged in diameter by using a boring tool.

The operation of boring is shown in Fig. 1.9. It is a delicate operation. The diameter of the boring tool or boring bar fitted with a tool bit has to be smaller than the hole in the work piece. The boring operation is really an internal turning operation but not being able to see the actual cutting, makes the operation tricky and delicate.

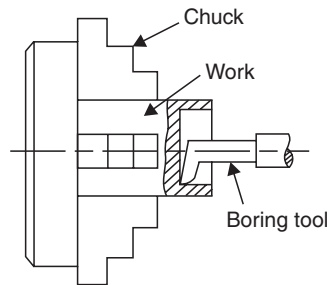

Fig. 1.9 Boring

Threading: Threading is an operation of cutting threads or helical grooves on the external cylindrical surface of the job. In this process, the carriage is connected to the lead screw. The pitch of threads to be cut equals $\frac{\text{r.p.m. of lead screw}}{\text{r.p.m. of workpiece}} \times \text{Pitch of lead screw}$. Thus there should be an arrangement to change the ratio of r.p.m. of work piece and the r.p.m. of lead screw. This is done by a system of gears, which give the required ratio.

Threads have a standard profile. The cutting tool profile should match with this profile. Now the threads can be cut in the usual manner by traversing the tool by engaging the clutch between carriage and lead screw. Such screw cutting lathes are provided, with reversible motors. The r.p.m. of spindle is kept very low for thread cutting.

Knurling: For providing better grip, some work pieces are provided with a shallow diamond shaped pattern on its circumference. Knurling rollers, which have a similar pattern cut on their surface are hardened. When a work piece surface is required to be knurled, the work piece is held in a chuck and rotated and the knurling roller is clamped in the tool post and by moving the cross slide, the roller is pressed into the surface of the work piece. As the roller and work piece surface rotate together, the pattern is etched into the surface of the work piece.

Conclusion: There are many accessories and fittings, which, if provided greatly improve the performance and range of work which can be carried out on a lathe.

QUESTIONS

1. Make a sketch of a centre lathe and label its main parts.
2. List the various operations which may be performed on a centre lathe.
3. Describe at least three methods of taper-turning on a centre lathe.
4. Sketch some tools commonly used on a lathe.

Shapers and Planers

INTRODUCTION

Both shapers and planers are machine tools which produce a flat surface. They are capable of machining a horizontal, vertical or inclined flat surface. They employ single-point cutting tools which are essentially similar to single-point cutting tools used on lathe. In both these machine tools, the cutting tool is subjected to interrupted cuts, the tools cuts in forward direction and is idle in the return direction.

SHAPING MACHINES OR SHAPER

Principle of Working

Principal parts of a shaper are shown in Fig. 2.1.

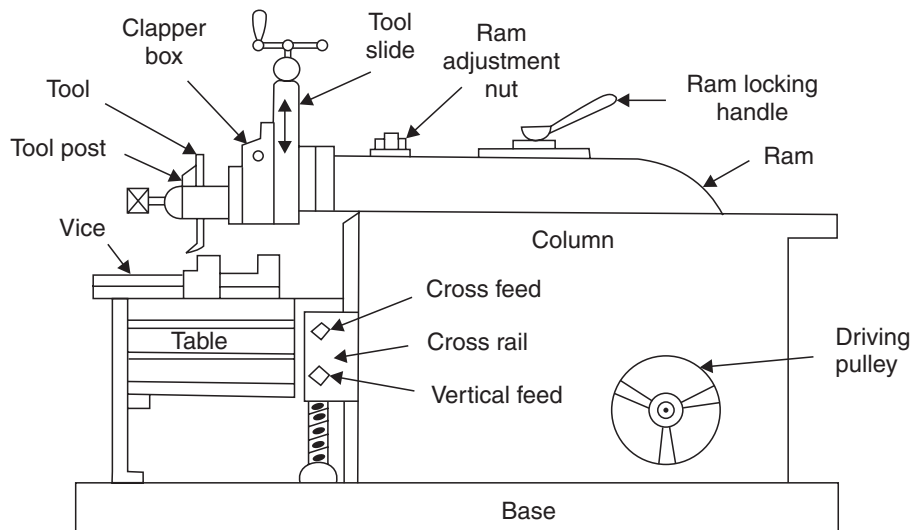

Fig. 2.1 Principal parts of a shaper

Shaper consists of a hollow machine bed made of cast iron which rests on the ground. Inside the hollow portion the machine drive mechanism is housed. This mechanism is called slotted lever quick return mechanism and it drives a horizontal ram which reciprocates in the guide ways provided on the top surface of the machine frame. In the front face of the ram, a tool post is fitted. This is a very special kind of tool post. It carries a slide which can be operated by a hand wheel and the entire tool post can be lowered or raised. Besides, the tool slide can be swivelled in a vertical plane and its inclination to the vertical (amount of swivelling) can be read off on a scale marked in degrees. The tool is inclined, when an inclined surface has to be machined.

In the front portion of the base, a table is fitted. The table can be raised or lowered to vary its height. It can also be moved horizontally to left or right. A vice to hold the work piece is provided on the table top.

The tool does useful work *i.e.*, cutting only in the forward stroke of the ram. It does not cut *i.e.*, it is idle during the return stroke of ram. In order that while returning, the tool may not rub and spoil the strip of the metal machined in the forward stroke, a special device called the “clapper box” is provided in the tool post. It lifts the tip of the tool during the return stroke.

DRIVE

Since useful work is done only during the forward stroke of ram, the mechanism driving the ram is so designed that the return stroke is completed in much less time than the forward stroke. The slotted lever quick return mechanism is illustrated in Figs. 2.2(a) and 2.2(b).

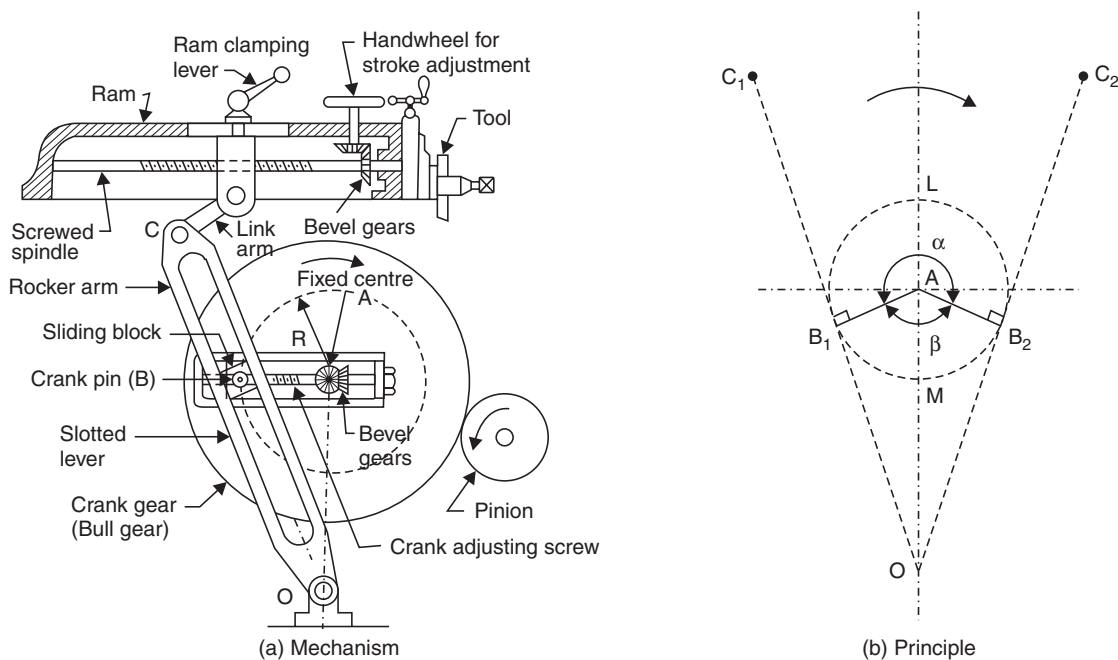

Fig. 2.2 Quick return mechanism

The crank AB (of adjustable length R) rotates with a uniform angular speed. The crank pin B is in the shape of a die block which is free to slide inside the slot in the slotted lever OBC . This slotted lever is pivoted at O and the other end C is connected to the ram by a short link arm as shown in Fig. 2.2 (a). When the crank AB rotates clockwise from position AB_1 to AB_2 , the ram moves forward from left to right and when it rotates from position AB_2 to AB_1 the ram returns back to its original position.

Clearly the time taken to complete forward stroke is proportional to angle α (refer to Fig. 2.2 (b)) and the return stroke is completed in less time which is proportional to angle β .

CUTTING TOOLS USED IN SHAPING

The cutting tools for shapers are generally made of H.S.S., either solid or with brazed tips. Due to interrupted cuts, tungsten carbide tools are not preferred for shaping work. These tools are made sturdy with fairly generous size for shank and tip. Various types of tools useful for shaping are shown in Fig. 2.3.

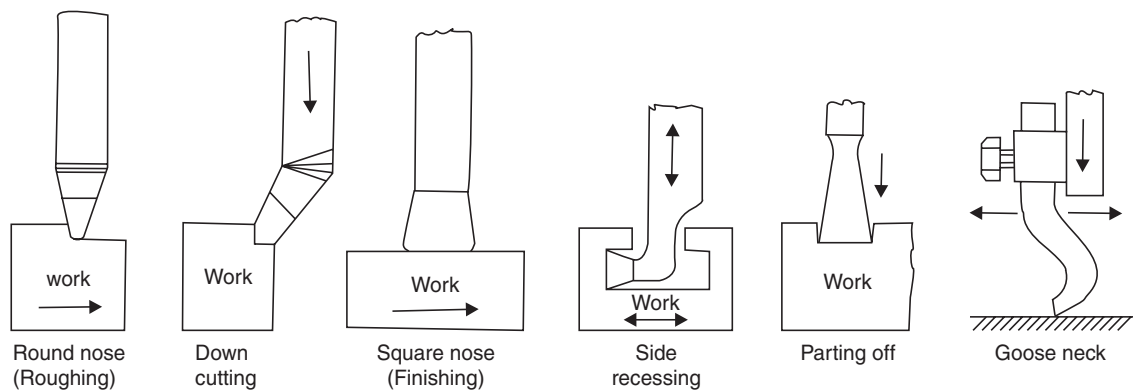

Fig. 2.3 Cutting tools used in shaping work

OPERATIONS PERFORMED ON SHAPERS

On a shaper machine, relatively small jobs can be machined. The size of a shaper is denoted by the maximum length of stroke of its ram and work pieces longer than the maximum stroke cannot be machined.

The first step in machining a job is to mount the job on the shaper-table and clamp it tightly in the vice or on the table by means of T -bolts etc. The second step is to adjust the stroke of ram according to the length of work piece. The ram stroke is kept about 60–70 mm longer than job. The stroke can be reduced or increased by altering the length of the crank AB (refer to Fig. 2.2). Now by changing the position of the location where short link arm is connected to the ram, the stroke is made to overlap the job, so that the stroke starts 30–35 mm before the job and covers the whole length of work piece and ends 30–35 mm beyond it.

A tool is now selected and clamped in the tool post. The depth of cut is given by rotating the hand wheel and lowering the tool slide. Depth of cut is not given by raising the table height. Table

height is adjusted only at the time of fixing the job according to the height of job. Feed is given by shifting the table laterally. The feed to the table can be given either manually or automatically. The feed is given during the return stroke of ram. Operations performed on a shaper can be easily understood from Fig. 2.4.

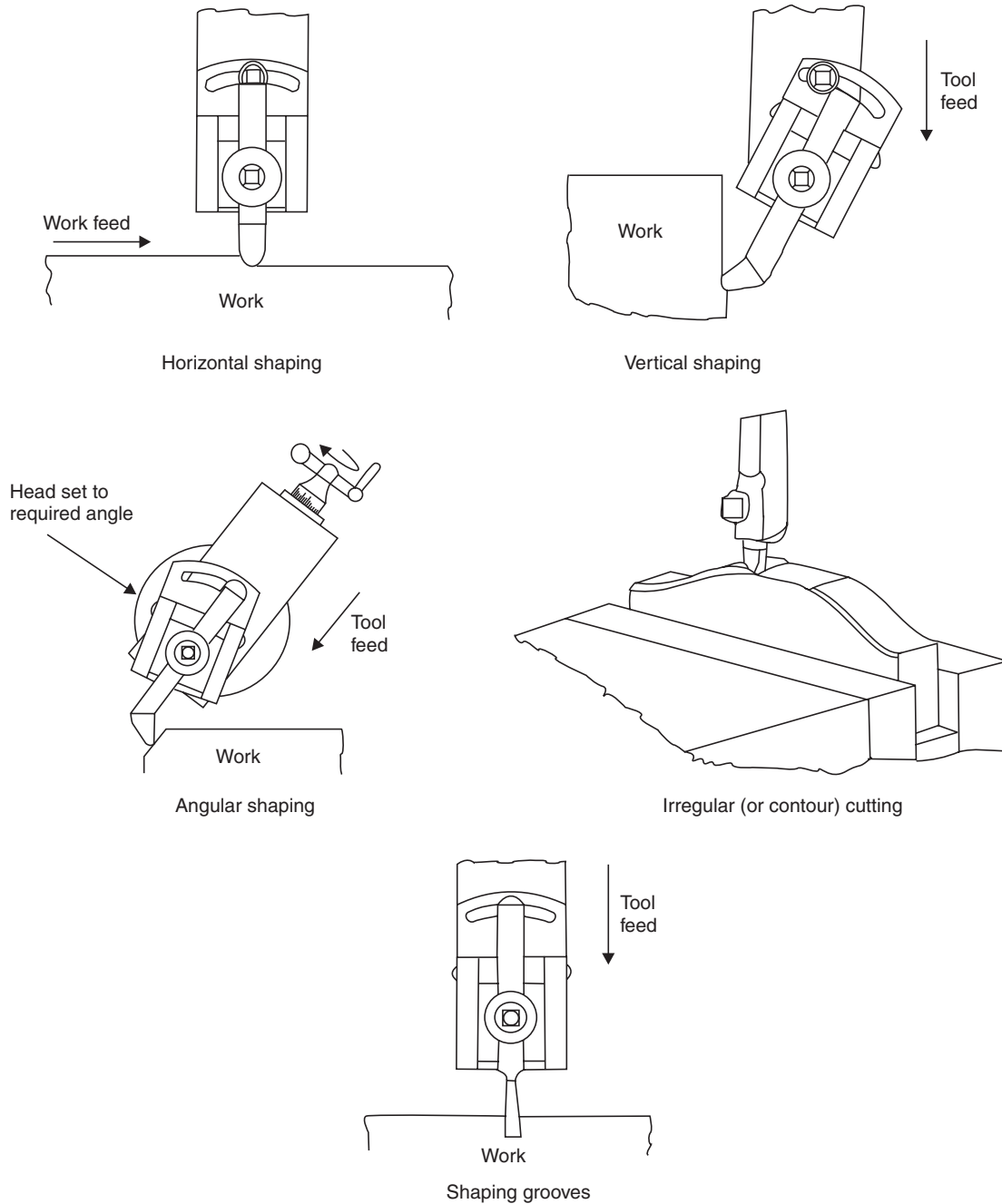

Fig. 2.4 Various operations performed on a shaper machine

Contour cutting is a very skillful job as it calls for simultaneous operation of horizontal table feed as well as vertical hand feed of the cutting tool. It can be performed only by a very skilled operator.

PLANER OR PLANNING MACHINE

Planer is used to machine flat surfaces on work pieces, which are too large and heavy to be accommodated on a shaping machine table. The fundamental difference between a planer and shaper is that in a planer, the cutting tool remains stationary and the planer table on which the work piece has been clamped moves past the cutting tool. The feed is given to the cutting tool and not to the table which reciprocates in the guide ways provided in the machine bed.

A planer can handle much heavier cuts and more than one tool post is provided on one machine so that machining can be done quickly. Sometimes a horizontal surface and a vertical surface are machined simultaneously and the squareness of the surfaces is automatically ensured.

PRINCIPLE OF WORKING

A standard planer is shown in Fig. 2.5.

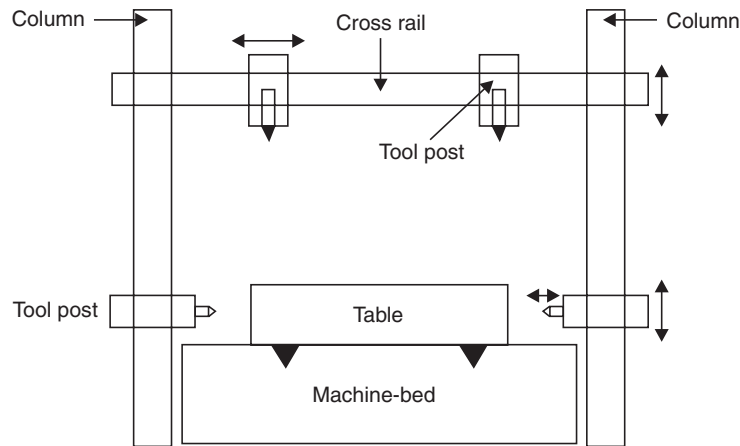

Fig. 2.5 Schematic diagram of a planer

The planer consists of a sturdy bed made of cast iron, on the upper surface of which Vee-guideways are machined all along the length of the bed. The base of the bed is grouted in the ground. The table is again made of cast iron having matching guide ways machined at its bottom so that it can slide longitudinally on the machine bed. The table has a long rack machined in the centre of its width which is used for giving reciprocating motion to the table. The table is provided with T-slots on its top surface, so that the work piece may be clamped securely on the table. Two vertical columns, one on each side of the bed and table are located as shown in the figure. A cross rail can slide up and down on the two vertical columns. Usually one or two tool posts (tool heads) are mounted on the cross rail and one side tool head is mounted on each column. Vertical tool heads can move laterally on the cross rail while side tool heads can move up and down on the vertical columns. There is an arrangement for advancement or retraction of tools in the tool heads.

A number of speeds and feeds are available for the tool heads.

Even on a planer, the tools will cut material only in the forward stroke of the table, its return stroke is idle. To save idle time, the return stroke takes place at higher speed. This is achieved by a variable speed reversible motor drive and a system of limit switches fitted on the bed of the machine, which get actuated when the table reaches the end of its forward and reverse strokes. The length of the stroke can be adjusted to suit the length of the work piece by changing the position of the limit switches.

Cutting tools used on planers: The planer tools are made of high speed steel, although tipped carbide tools are also used occasionally. These tools are, in general, similar to shaper tools, but are more robust and stronger. Specially shaped tools are used on planers for operations like *T*-slot cutting and dove tail slide cutting.

In both shapers and planers, the tool or table starts from rest, picks up speed and then again slows down to zero speed during the forward or cutting stroke. It is customary to calculate cutting speed on the basis of average speed during the forward stroke. Feed and depth of cut are both expressed in mm. In case of feed, it is the lateral distance moved by the tool (on the cross-rail) per cutting stroke.

Some examples of the diverse type of machining operations performed on a planer can be had by referring to Fig. 2.6. The surfaces shown shaded have been machined on planer.

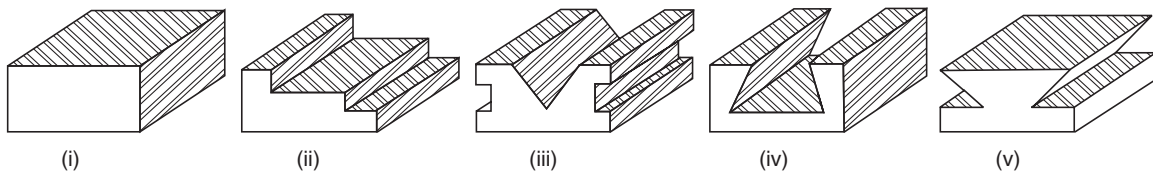

Fig. 2.6 Components manufactured by planning/shaping processes

QUESTIONS

1. Why quick return motion is provided in shapers and planers?
2. Sketch the quick return motion mechanism used in shaping machines and explain how stroke is adjusted to suit a particular job.
3. Make a sketch of a planning machine and explain how vertical and horizontal surfaces of a work piece can be planed simultaneously.
4. A work piece is to be machined. It has many plain surfaces. How will you decide if the work piece should be machined on a shaper or a planer?

Drilling Machines

The process of drilling means making a hole in a solid metal piece by using a rotating tool called drill.

In the olden days, a flat drill was used for drilling a hole, but these days, a twist drill is universally used. A twist drill is the cutting tool and it is used in conjunction with a drilling machine. A twist drill has two cutting edges, hence it is a multiple point cutting tool. The drilling operation is shown in Fig. 3.1.

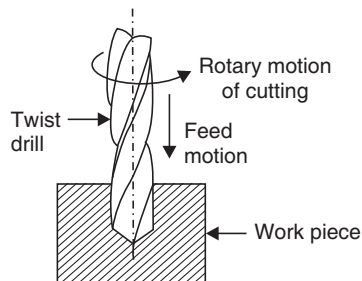

Fig. 3.1 Drilling of a hole

TWIST DRILL

A twist drill is shown duly labelled in Fig. 3.2. Twist drills usually have a taper shank, at the end which is fitted into the drilling machine having a tapered sleeve of matching taper. When the tapered sleeve rotates, the twist drill also rotates along with it due to the friction between two tapered surfaces. Sometimes the shank is machined parallel, then a special collet chuck is fitted in the drilling machine, in which the drill is held.

The drill has two lips at the other end where the cutting takes place, when the drill rotates. The angle between the two cutting lips is usually 118° . The chips formed at the cutting edges are automatically guided upwards through the helical grooves cut into the body of the drill; these grooves are called flutes. This is necessary, otherwise, the chips will interfere with the metal cutting.

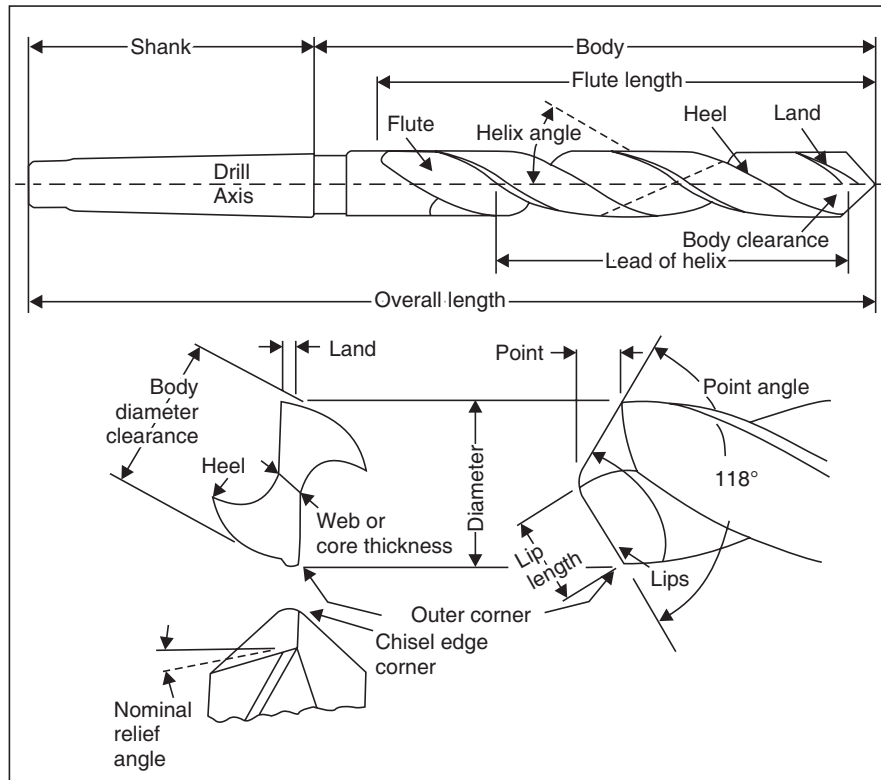

Fig 3.2 Nomenclature of a standard general-purpose twist drill

For rotating the drill and to overcome the resistance in cutting, a torque is needed to rotate the drill. An axial force is also needed which keeps pushing the drill deeper and deeper into the hole being drilled. This is provided by the machine feed. Machine feed is the downward axial movement of the drill per revolution of drill.

The drill will not start cutting the metal, if its bottom touches the metal surface superficially. This is on account of the chisel edge which does not allow the cutting edges to come into the contact with metal and start cutting until the chisel edge penetrates the metal surface by about a mm or so. To facilitate the cutting action, a little depression is made by a punch at the centre of the hole to be drilled.

Twist drills are made of solid high speed steel, hardened and ground to shape. Drills with tungsten carbide inserts are also available.

DRILLING MACHINES

Drilling machines are of the following types:

1. Sensitive drilling machines,
2. Pillar type drilling machines,
3. Radial drilling machines, and
4. Multispindle drilling machines.

Sensitive drilling machines: A sensitive drilling machine is shown in Fig. 3.3.

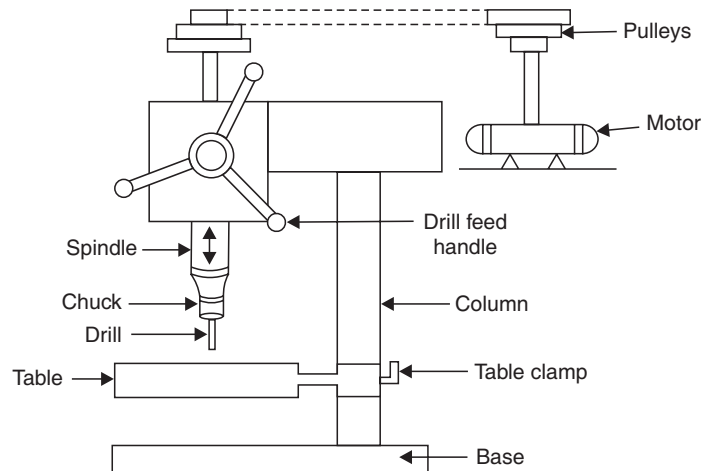

Fig. 3.3 Sensitive or bench drilling machine

This is a light duty machine and is capable of drilling a hole of 12 mm dia maximum and its spindle speeds are correspondingly high. This machine can tackle small jobs. The work piece is kept on the table and clamped in the appropriate position and the hole is drilled by lowering the spindle of the drilling head. Feed is given by moving the hand wheel gently which lowers the spindle and the hole is drilled up to the required depth. Remember that the job has to be moved so as to align the centre of hole exactly below the spindle.

Pillar type drilling machines: These are generally similar to sensitive drilling machines but are meant for heavier work. The vertical column can be either of rectangular or round section; the latter offers the advantage that the table can be swung out and the slightly bigger jobs can be accommodated on the machine base instead of the table. The drilling head can be lowered and hole drilled in the job.

Radial drilling machine: A radial drilling machine is illustrated in Fig. 3.4. This is really meant to drill holes in bigger and heavier workpieces, which cannot be manipulated so that the centre of the hole may be aligned with the drilling spindle. In this case, the drilling head is mounted on a radial arm. The radial arm can be rotated around the round column and the drilling head can be moved in or out on the radial arm.

The work piece is kept on the table which is really an integral part of the base and by the combined movement of the radial arm and the drilling head (think of the polar coordinates θ , r), any point on the work piece can be covered and a hole drilled at the required location, without shifting the heavy work piece.

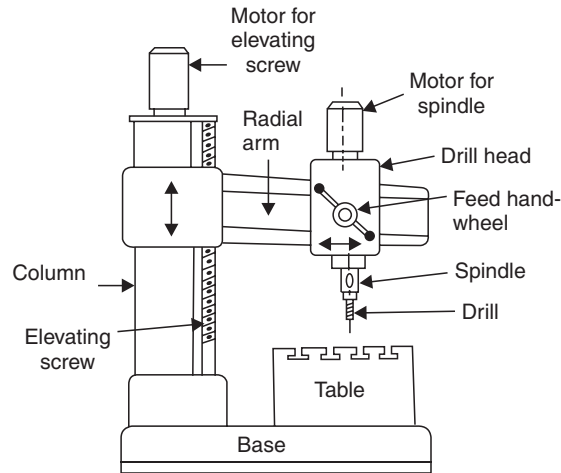

Fig. 3.4 Radial drilling machine

Multiple spindle drilling machines: On these machines, more than one hole may be drilled at one time. These machines are very useful for mass production work.

Allied operations performed on drilling machines: Operations closely associated with drilling are shown in Fig. 3.5.

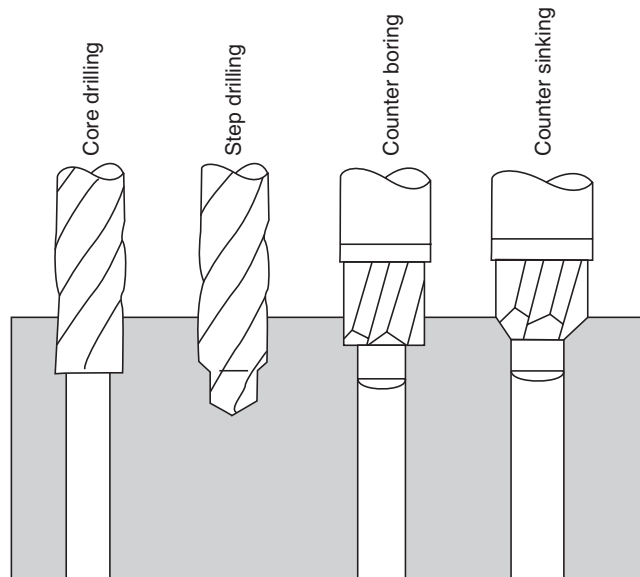

Fig. 3.5 Common operations closely associated with drilling

Core drilling: Holes made in castings by use of cores, are rough and require a special kind of drill, called core drill to clean up the holes. This operation is called core drilling.

Step drilling: More than one diameter can be ground on the drill body which saves an extra operation.

Counter boring: Often a flat surface is needed around a hole to provide a good seating area for washer and nuts/head of a bolt. The counter boring tool has a pilot, which ensures that the counterbore is concentric with the hole.

Counter sinking: Counter sinking provides a tapered entrance to the hole. A special counter sinking tool with a pilot is used as shown.

Reaming: Reaming is an operation of sizing and improving the geometry and finish of a previously drilled hole. Hand, machine and shell reamers are used for this purpose. Machine reamers are used with a drilling machine. To work efficiently, proper stock allowance is very important. Reamers cannot remove much material, but at the same time, enough material should be available all round. For holes up to 12.5 mm in diameter, about 0.38–0.4 mm of material is left as reaming allowance.

A reamer follows the original hole and cannot shift its centre.

Tapping: Tapping is also done on a drilling machine with a special flexible adapter for holding machine taps. Tapping means cutting internal threads in a hole. A machine tap set consists of two taps—rough and finish. Both taps should be used in the same order. During tapping, the spindle r.p.m. is drastically reduced and a good lubricant used.

QUESTIONS

1. Make a sketch of a twist drill with a taper shank. What part of the drill is used for cutting? How is the twist drill fitted in the drilling machine?
2. Describe the various kinds of drilling machines, you are familiar with.
3. Write brief notes on:
 - (i) Reaming
 - (ii) Core drilling
 - (iii) Counter boring.
4. Can 'tapping' be done on a drilling machine? If yes, describe the process in detail.

Milling Process

INTRODUCTION

Milling is a machining process which is performed with a rotary cutter with several cutting edges arranged on the periphery of the cutter. It is a multiple point cutting tool which is used in conjunction with a milling machine. This process is used to generate flat surfaces or curved profile and many other intricate shapes with great accuracy and having very good surface finish. Milling machines are one of the essential machines in any modern machine shop.

BASIC MILLING PROCESS

Generally, there are two types of milling processes. These are called (a) Up milling or conventional milling process, and (b) Down milling or climb milling process. Both these processes are illustrated in Fig. 4.1.

In upmilling, the direction of rotation of milling cutter and the direction of work piece feed are opposite to each other; whereas in down milling, they move in the same direction at the point of contact of the cutter and the workpiece. In upmilling, the thickness of chip at the start is nil and is maximum when the cutting teeth leave the surface of the work piece. In down milling, it is vice-versa. In up milling, the cutting teeth try to up root and lift the work piece from the machine table, in down milling, reverse happens. Technically, downmilling is a superior process, but up milling is commonly used. Down milling is not used unless the milling machine is fitted with a backlash eliminator.

From Fig. 4.1, basic milling operation can also be understood. The milling cutter is circular and a large number of cutting edges (or teeth) are arranged along its circumference. The cutter is rotated at a speed of N r.p.m. If the cutter diameter is D , then cutting speed at the tip of teeth can be calculated as πDN metres/minute and it should conform to the recommended values. The depth of cut is clearly shown in the figure and the thickness of the work piece will reduce by this amount in one pass. Usually, the width of the milling cutter is more than the width of the work piece, hence one pass is all that is required.

Feed of the work piece is measured in terms of mm/minute. Actually, the correct measure of feed is movement of work piece per revolution of cutter per teeth. If a milling cutter has z number of

teeth and if the table feed is ' f ' mm/minute, feed per rev per teeth will be f/NZ mm. It should therefore be clear that metal removal rate in milling operation is much higher than in shaping or planing operations.

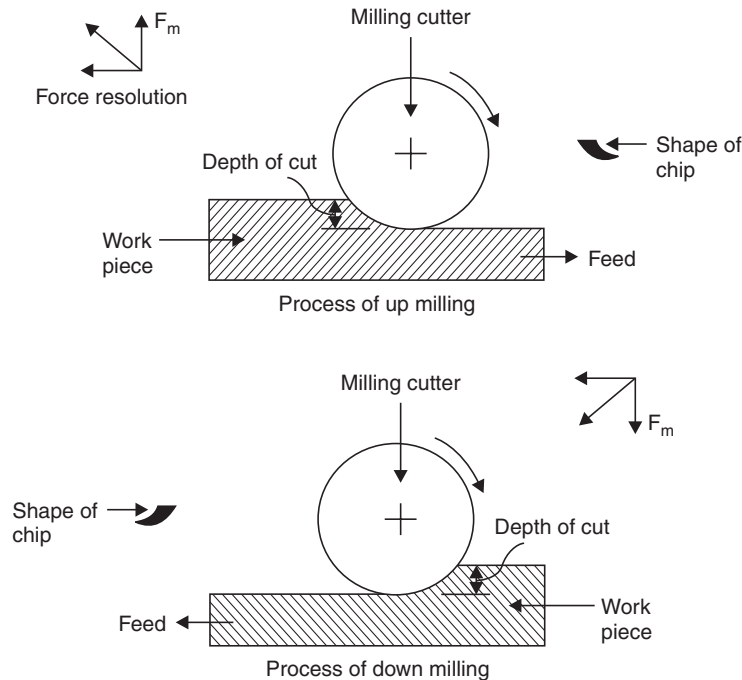

Fig. 4.1 Up and down milling processes

However, as in shaping or planing operation, the stroke length is always a little more than the length of the job, in milling operation also, the minimum table traverse required is $L + D$, where L is the length of job and D is the milling cutter diameter. $D/2$ is the minimum overlap required on either side of job, so that the cutter becomes clear of the job.

Unlike turning, the milling process involves intermittent cutting and the chip cross-section is not uniform. The high impact loads at entry as well as fluctuating cutting force make milling process subject to vibration and chatter. This aspect has great influence on design of milling cutters.

TYPES OF MILLING PROCESSES

The milling process is broadly classified into peripheral milling and face milling. In peripheral milling, the cutting edges are primarily on the circumference or periphery of the milling cutter (in Fig. 4.4, cutters shown are peripheral cutters) and the milled surface is generally parallel to cutter axis.

In face milling, although the cutting edges are provided on the face as well as the periphery of the cutter, the surface generated is parallel to the face of the cutter and is perpendicular to the cutter axis. Refer to Fig. 4.2; in which both these process have been illustrated.

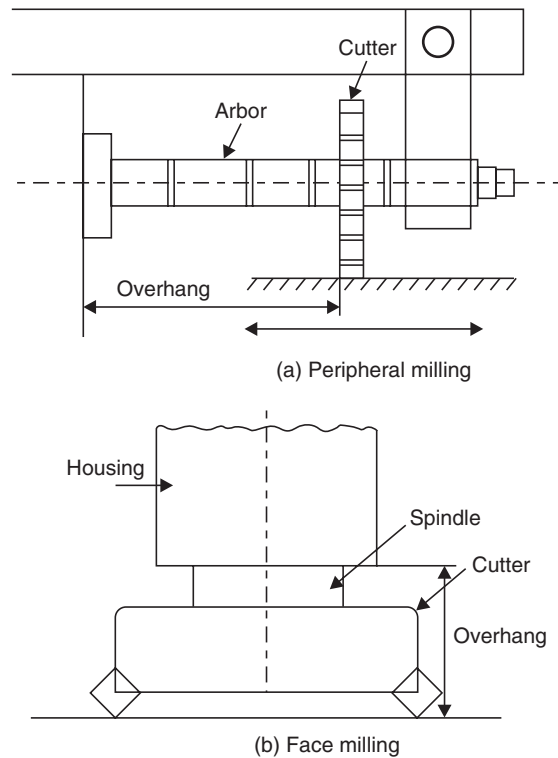

Fig. 4.2 Peripheral and face milling

The peripheral milling cutters are supported on a long arbor. The deflection of arbor restricts the dimensional and form accuracy of this process. In face milling, the overhang of the cutter is limited resulting in better dimensional control and flatness. Peripheral milling cutters are normally used with a horizontal milling machine whereas the face cutters are used in conjunction with a vertical milling machine.

Milling cutters are made of solid high speed steel, or have high speed steel inserts. The cutters are also made, with tungsten carbide blades (either brazed or with throw away inserts).

PERIPHERAL MILLING

Peripheral milling is adopted for the following machining operations:

1. Slab milling to produce flat surfaces.
2. Slot milling to produce precision slots.
3. Side and face milling to machine adjacent horizontal and vertical surfaces simultaneously.
4. Form milling to produce prismatic shape of any form, *e.g.*, involute form in gear cutting.
5. Straddle milling to machine two parallel vertical faces.
6. Gang milling to machine a number of surfaces simultaneously with a set of cutters.

The various peripheral milling operations are illustrated in Fig. 4.3.

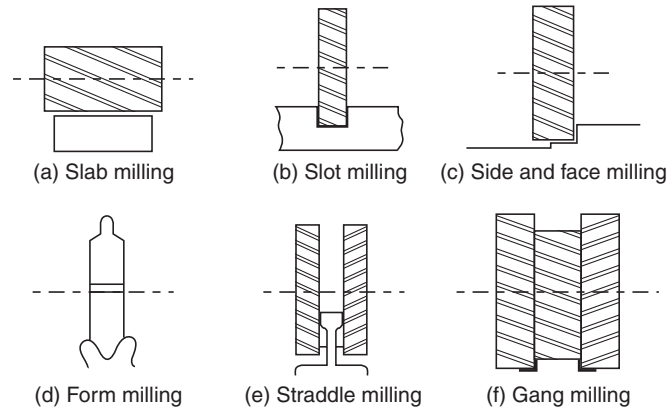

Fig. 4.3 Various peripheral milling operations

A number of milling cutters of peripheral milling type are shown in Fig. 4.4. The hole and the keyway provided in the centre of all peripheral cutters is for mounting them on the arbor of a horizontal milling machine.

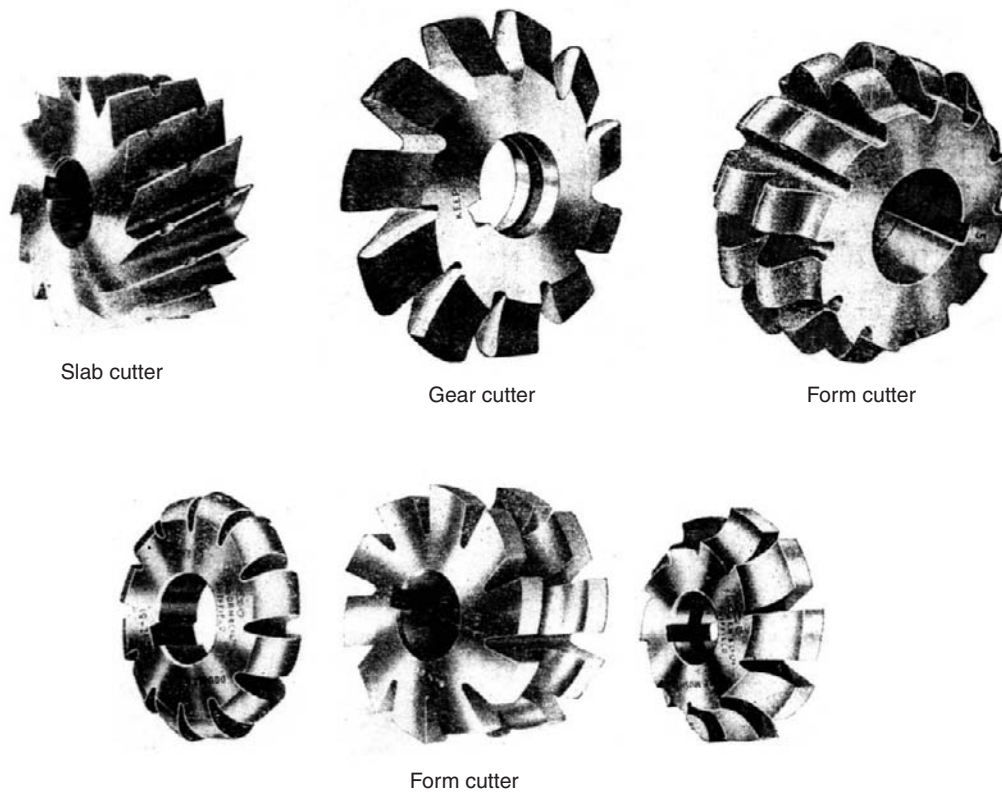

Fig. 4.4 Peripheral milling cutters

FACE MILLING

Face milling is widely used for milling operations involving high metal removal rate. The operation of face milling with a face milling cutter having coated tungsten carbide inserts is shown in Fig. 4.5.

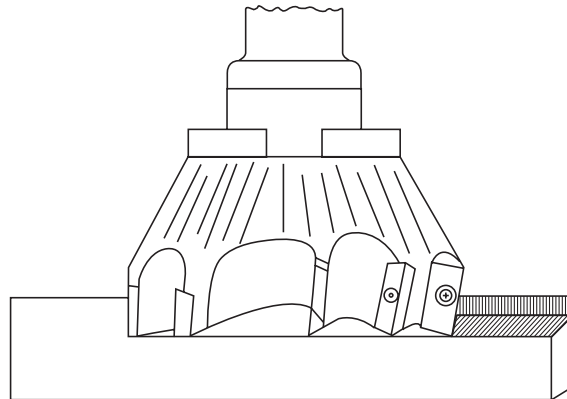

Fig. 4.5 Face milling

Face milling is a combination of up cut and down cut milling operation. The points discussed earlier about up and down milling operations in peripheral milling, apply equally well to the face-milling operation (refer to Fig. 4.6)

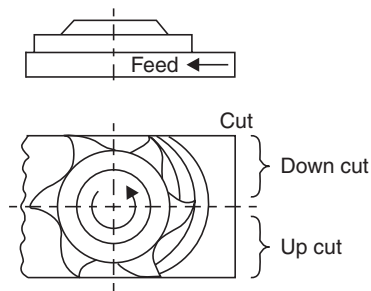

Fig. 4.6 Down and up cut in face milling

In face milling, the position of the cutter with respect to the workpiece is of considerable significance. Three possibilities are there. Either the cutter may be symmetrically placed on the work piece or it may be asymmetrically placed, offset slightly towards the entry side or it may be asymmetric, offset slightly towards the exit side. All three positions are shown in Fig. 4.7.

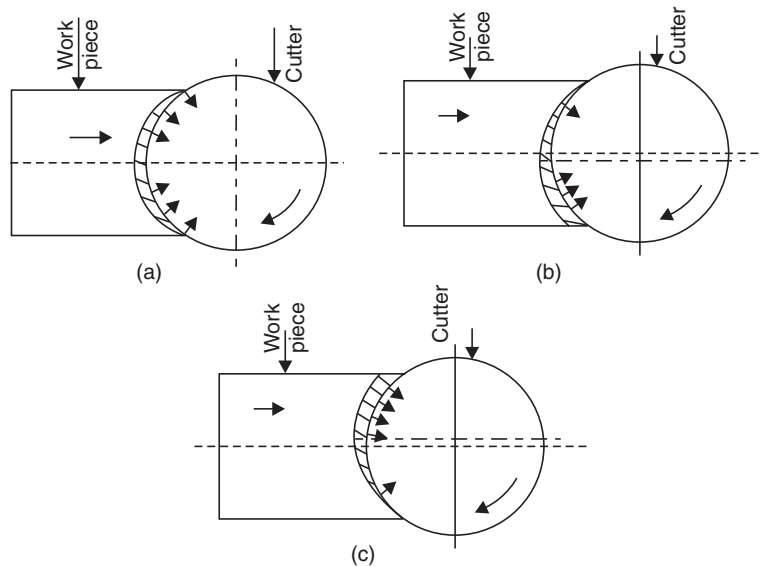

Fig. 4.7 Symmetrical vs asymmetrical milling

Asymmetric milling with larger chip thickness at entry and smaller chip thickness at exit (Fig. 4.7 (b)) is ideal and should be adopted.

END MILLING

End mills perform a combination of peripheral as well as face milling operations simultaneously. It has got cutting edges on the bottom face as well as on its periphery. End mills are extremely useful and are used for machining edges, shoulders, grooves, slots and keyway pockets. They are also widely used for die-sinking and generation of sculpted surfaces.

Today, end mills are available in many tool materials:

1. Cobalt high speed steel (super H.S.S.)
2. Coated H.S.S.
3. Solid carbide
4. Micrograin solid carbide
5. Indexable inserts of cemented carbide or coated carbide.

A solid carbide end mill and its applications in shoulder and pocket machining are shown in Fig. 4.8. End mills have a taper shank which fits into a taper sleeve provided in the spindle of a vertical milling machine.

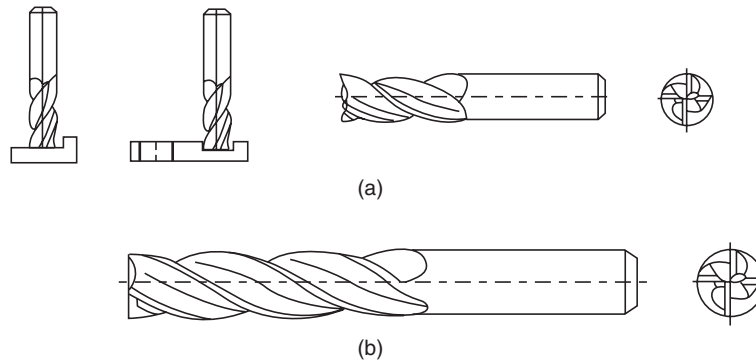

Fig. 4.8 Solid carbide end mills (a) short series (b) long series

MILLING MACHINES

All the milling cutters described above are used in conjunction with milling machines, which provide rotary movement to the cutters, and feed to the workpiece and arrangement for clamping, automatic feed etc. Milling machines come in three basic models:

1. Horizontal milling machines,
2. Vertical milling machines, and
3. Universal milling machines (This is also of horizontal type with a few special features).

Other configurations of the milling machine have been developed for special applications, but above three are most common.

HORIZONTAL MILLING MACHINE

The most common type of milling machine is the horizontal knee type; so called, because of the overhanging “knee” which can slide up and down the front of the machine and which carries the cross slide and the table. A diagram of the horizontal milling machine is given in Fig. 4.9.

Horizontal milling machines may be either plain or universal type. The main difference between the two is that the table of the universal type is mounted on a turn table and may be swivelled in a horizontal plane. This feature permits the cutting of helix. In addition, the standard accessories provided on the universal machine include a ‘dividing head’ for indexing. There are some other minor refinements, which make the universal horizontal machine very useful for tool room work.

The plain version of the horizontal machine is much more robust and more suitable for production work. In the diagram, the arbor on which peripheral cutters are mounted is not shown. It is fitted in the spindle nose ‘C’ and extends a little beyond arbor supporting bracket ‘B’.

Even end mills, face milling cutters and drills etc. can be used with this machine. In such a situation, arbor is removed and the taper shank of these cutters is fitted into the hollow spindle ‘C’. With such an arrangement the vertical faces of the workpiece may be milled without any difficulty.

The table of the horizontal milling machine can be given either hand feed or autofeed. It is also capable of being traversed at high speed.

With these features, the machine proves really useful.

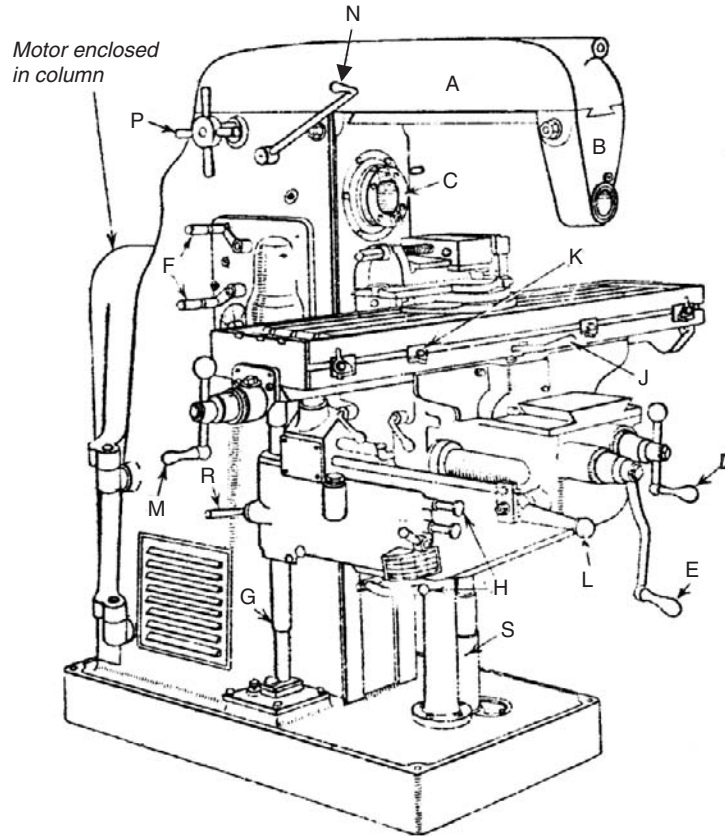

A. Overarm; B. Arbor supporting bracket; C. Spindle nose; D. Hand cross feed; E. Hand vertical feed; F. Speed change levers; G. Feed driving shaft (enclosed); H. Feed change levers; J. Table feed actuating lever; K. Feed trip; L. Rapid power feed control; M. Hand table feed; N. Starting lever; P. Wheel for moving overarm; R. Feed reversing lever; S. Tube to deliver cutting fluid to reservoir in base.

Fig. 4.9 Horizontal milling machine

Vertical milling machine: The application and technique of this machine differ from that of a horizontal milling machine. It does not have an arbor and instead has a vertical spindle into which the taper shank of end mills and facing milling cutters and drills etc. can be fitted. The arrangement and movement of table are similar to the table of a horizontal milling machine.

A vertical milling machine is shown in Fig. 4.10.

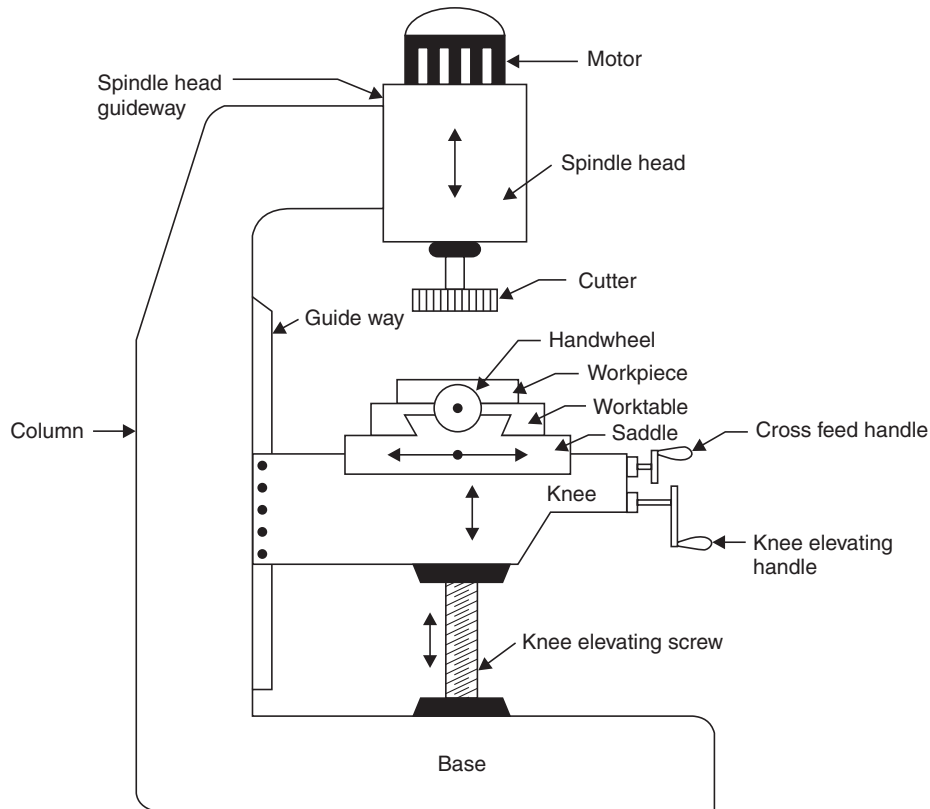

Fig. 4.10 Vertical milling machine

This machine used for making, flat surfaces, grooves, slots, pockets and guideways etc. in workpieces using end mills and facing mills etc.

Universal milling machine: Its features have already been described under the heading of horizontal milling machine.

QUESTIONS

1. What is the difference between “up milling” and “down milling”?
2. How can a keyway be machined on a shaft?
3. Make a sketch of a slab milling cutter, a face mill and an end mill.
4. Describe a horizontal milling machine. How is a milling cutter fixed in this machine?

Grinding Process

INTRODUCTION

In grinding process an emery or corundum wheel is used as the cutting tool. Emery and corundum are naturally found abrasives and are impure form of aluminium oxide Al_2O_3 . A grinding wheel is made up of thousands of tiny abrasive particles embedded in a matrix called the 'bond'. An abrasive is an extremely hard material second in hardness only to diamond. The edges of the abrasive particles project out of the periphery of the grinding wheel, and when grinding wheel rotates, each one of the particles acts like a tiny cutting tool machining away the material from the surface of the work piece. To the naked eye the cut material looks like metal dust mixed with powder from the grinding wheel. However, seen under magnifying lens, the metal dust shows all the characteristics of metal chips produced in other machining processes. The grinding process is truly a chip producing machining process.

The grinding process is capable of producing very accurate sizes, equally accurate geometry like flatness or circularity and extremely good surface finish. The grinding wheel is capable of machining hardened steel and even hardened high speed steel, which cannot be done by other machining processes.

When a grinding wheel is applied to the workpiece, the sharp edges of the abrasive grains which are cutting, will eventually lose their cutting effect and become dull. At that stage, the abrasive grain should either split and form new edges or it should break away from the wheel exposing the next layer of grains to do their work. If the dulled grains stay in the wheel, they simply keep on rubbing on work without actually cutting. This defect is known as 'glazing'. If on the other hand, the abrasive grains break away from the wheel or split prematurely, before becoming dull, it causes reduction in life of grinding wheel.

CHOICE OF ABRASIVES

Emery and corundum, are no longer used in modern grinding wheels. Instead artificially manufactured abrasives are used due to their high purity. These abrasives are (a) silicon carbide, and (b) aluminous oxide, Al_2O_3 . Silicon carbide is greenish black in colour, whereas aluminous oxide is reddish brown. Silicon carbide is harder and more brittle than alumina. For this reason, it is used for grinding materials of low grinding resistance like cast iron, brass, copper etc. Aluminium oxide abrasive is more suitable

for grinding most steels because of its greater toughness to cope with increased grinding resistance offered. The code for silicon carbide is *C* and for Al_2O_3 wheels it is *A*.

Apart from the abrasive, the performance of a grinding wheels also depends upon many other factors. It is important that a suitable grinding wheel is selected for a particular application. The basis of some factors are discussed under the heading “classification of wheels”.

CLASSIFICATION OF WHEELS

Classification of wheels is based on the following characteristics:

GRIT

Grit indicates, the size of abrasive grain. It is indicated by a number. Higher the number, smaller the size of grains. Abrasives finer than 200, are called “flours” designated as *F*, *FF*, and *FFF*. These and finer abrasive ‘flours’ are used by jewellers. For fine finish of ground surface, smaller grit size abrasive wheels are used. But their metal cutting capacity is limited. With larger size abrasive wheels, finish is rough but metal removal rate is higher.

BOND AND GRADE

Bond refers to the substance of which the matrix of the grinding wheel is made. The degree of hardness possessed by the bond is called the grade of the wheel and indicates the strength of the grip with which the abrasive grains are held in the bond.

The following bonds are generally employed in manufacture of grinding wheels:

1. **Vitrified bond:** It is denoted by letter *V* and about 80% of the wheels used in the industry are of this bond.
2. **Silicate bond:** It is denoted by letter *S* and silicate of soda (commonly known as water glass) is the main constituent of this bond.
3. **Shellac bond:** It is denoted by letter *E* and shellac (a naturally available material) is the main constituent of the bond.
4. **Rubber bond:** Here the abrasive is kneaded in rubber and the wheels are moulded from this material. Denoted by letter *R*.
5. **Resinoid bond:** These wheels are made from bakelite and other resinous material. It is denoted by letter *B*.

The bond hardness or grade is usually represented by the letters of English alphabet. *A* represents very soft grade, while *Z* is very hard *M* and *N* represent medium grade hardness.

WHEEL STRUCTURE

The proportion of bond material in a wheel varies from about 10% to 30% of its total volume. Structure of wheel depends upon this percentage. If abrasive grains are too tightly packed, the percentage of bond material will be on the lower side. This is called a closed structure. If the abrasive grains are less tightly packed in the same volume, the wheels are said to have an open structure. The structure is indicated by a number varying from 1 (very closed structure) to 15 (very open structure).

On every grinding wheel, the manufacturers are obliged to give the following information, in specified sequence about the

- (a) Abrasive used (A or C)
- (b) Grit number (e.g., 46)
- (c) Grade (A to Z)
- (d) Structure (1 to 15)
- (e) Bond Type (by specified letters).

In addition, the manufacturer is free to supply some additional information as prefix or suffix to the above information.

WHEEL SHAPES

Grinding wheels are made in a wide variety of shapes to suit the immense range of work and special features of machine tools on which the wheels shall be put to use. Many common shapes are shown in Fig. 5.1.

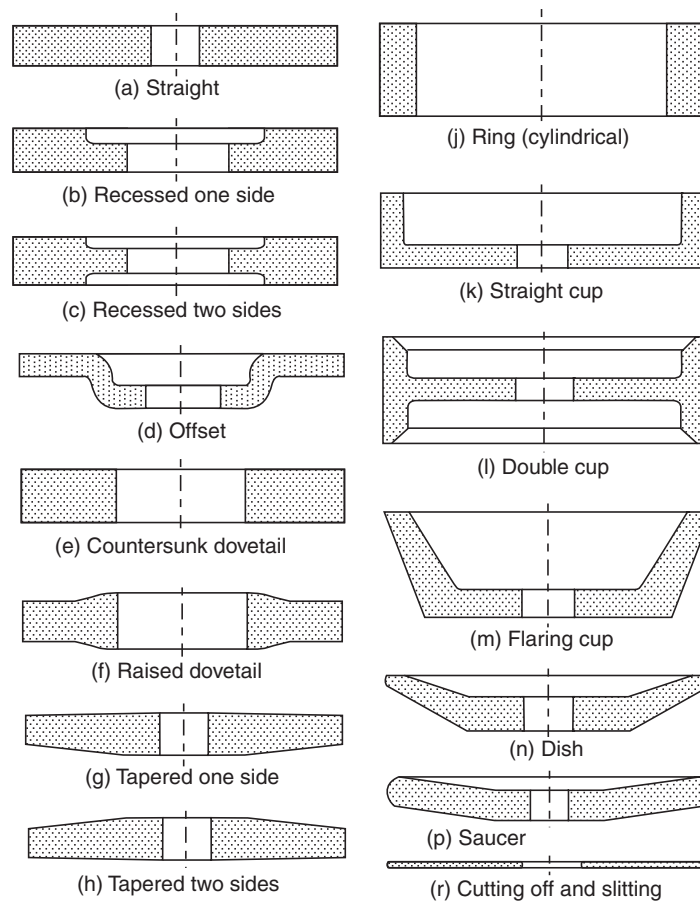

Fig. 5.1 Grinding wheel shapes

Wheels from (a) to (h) are disc wheels and grinding is to be done on the periphery of the wheel. Wheels (j) to (l) are mostly used on cup wheel grinders. Wheels (m), (n) and (p) are used for tool and cutters grinding. The thin wheel shown at (r) is used on abrasive cutters for slitting and parting off.

Wheel selection: It means choosing the most appropriate wheel for a particular grinding operation. Obviously, wheel selection would depend upon what abrasive is required, and other characteristics of the wheels. But it also depends upon many operating conditions like wheel and workspeed, relative diameters of wheel and jobs, type and condition of machines etc. Therefore it is best to refer to a wheel manufacturer and go by his recommendations. Thumb rule is to use a hard wheel for soft material and soft wheel for hard material. A hard wheel retains the abrasives as they do not get dulled easily on soft material.

MOUNTING A WHEEL ON MACHINE, BALANCING, TRUING AND DRESSING

A grinding wheel is a delicate and fragile tool. Unless it is used properly, it may not give optimum service or may even result in accidents. In this respect correct mounting and balancing is of utmost importance. Balancing is needed as wheels revolve at many thousand r.p.m. and any unbalanced centrifugal forces may crack the wheel or spoil the bearing.

As soon as a fresh wheel has been fitted on a grinding machine spindle, it will be necessary to true its face and perhaps, its sides for a short distance down so that the wheel may become, square to the work piece. Truing or dressing also become necessary after the wheel has been in use for sometime, to correct for non uniform wear on its face or for opening up its face to obtain efficient cutting conditions.

The truing or dressing up of grinding wheels is done by a diamond tool. Being harder, it is able to cut through, the abrasive grains and the bond material.

GRINDING OPERATIONS AND GRINDING MACHINES

The common grinding operations are

(a) **Cylindrical grinding:** This operation is carried out on a cylindrical grinding machine which is made in two varieties “plain” and the “universal” type. The fundamental design is the same in both cases, but the universal machine can be adopted for internal grinding operation as well.

In cylindrical grinding operation, the work is mounted between two centres and is rotated. A grinding wheel is mounted on a spindle and revolves at much higher r.p.m. than the work. The work centres are mounted on a table which can traverse at various feeds so that the entire length of the work passes to and fro in front of the wheel. The depth of cut is very small, about 0.015 mm. When the entire length of work has passed in front of the wheel, the wheel advances forward by another 0.015 mm at the end of the traverse and so the cycle of machining goes on, until the desired diameter of the work piece is reached. The result is a long cylinder of perfectly circular profile with very fine surface finish.

A schematic diagram of the plain cylindrical grinder is given in Fig. 5.2.

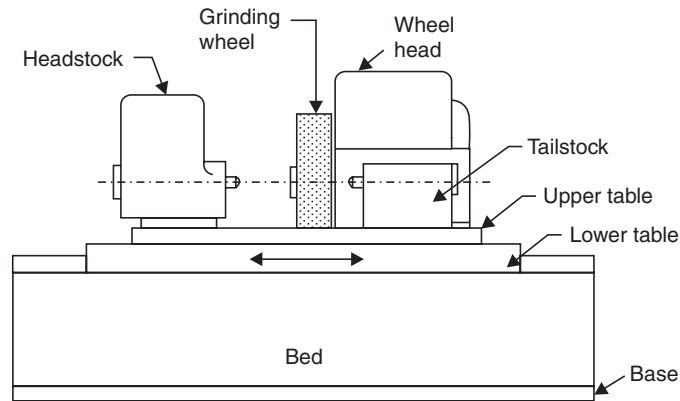

Fig. 5.2 Block diagram of a plain cylindrical grinder

(b) **Internal grinding:** Internal grinding operation means, grinding of internal holes or bores. The principle of internal grinding is shown in Fig. 5.3.

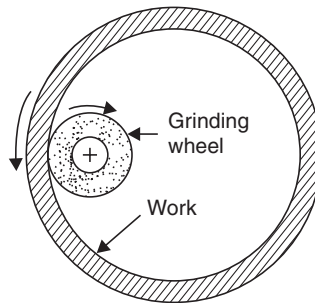

Fig. 5.3 Principle of internal grinding

Internal grinding is designed to grind the surface of bores; whether plain or tapered with the help of a small grinding wheel mounted on a long slender spindle which can enter in the bore. It is capable of giving improved geometry of the hole as well as the surface finish. This operation is performed on specially designed internal grinding machines. For internal grinding, a softer wheel is generally preferred.

(c) **Surface grinding:** A flat surface can be ground in many ways with a grinding wheel. Some possible configurations are illustrated in Fig. 5.4.

Recently surface grinding has emerged as a very important operation. Flat surfaces may be ground either by using the periphery of a disc wheel or by grinding with the end of a cup-shaped wheel. These methods can be further sub classified according to the method of feeding the work to the wheel. The method of using disc wheels entails the use of a horizontal spindle grinding machine. The cup wheels may be used in conjunction with either a horizontal or vertical spindle machine.

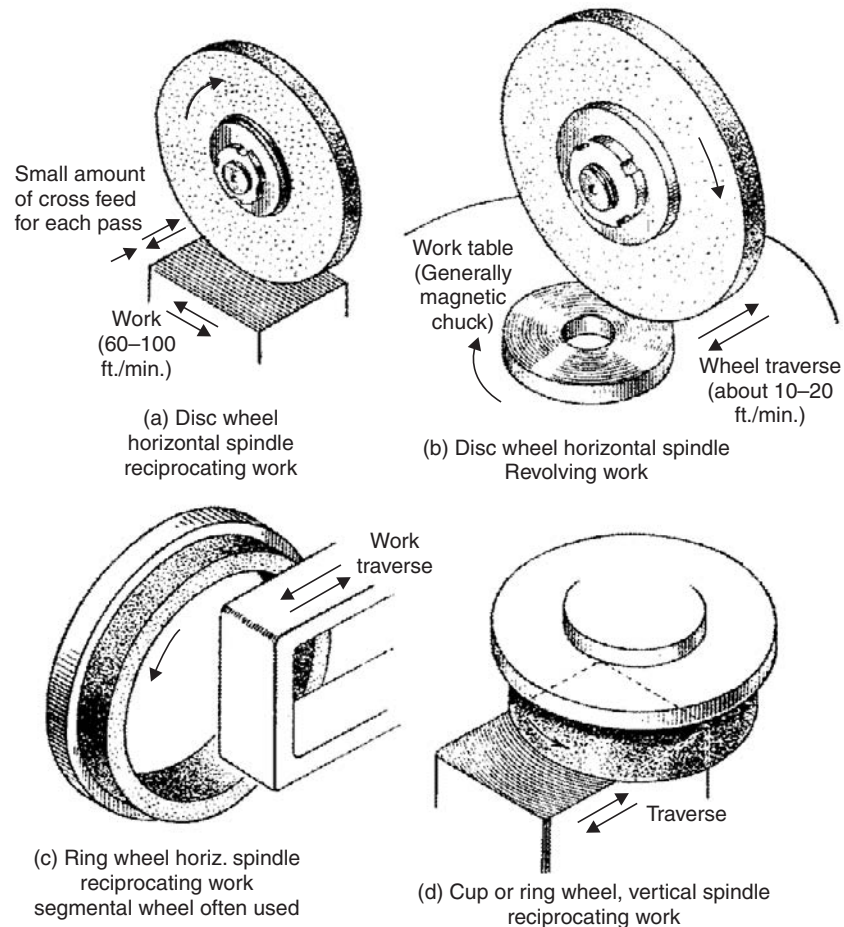

Fig. 5.4 Methods of surface grinding

Wheel speeds: The wheel manufacturer specifies a maximum safe r.p.m. for the wheel. In actual operation, this speed should never be exceeded. Like conventional machining methods, the concept of cutting speeds applies to grinding wheels also. The average recommended wheel speeds in metres per minute for different grinding operations are given below.

Cylindrical grinding	2000 metres/minutes
Internal grinding	700-1000 metres/minutes
Surface grinding	1200-1600 metres/minutes
Cutting off with rubber, shellac and bakelite wheels	3000-4000 metres/minutes.

In cylindrical grinding operation, work is made to rotate at a r.p.m. which works out to about 20-25 metres/minutes speed.

COOLANT

In the grinding operation, lot of heat is generated. This heat must be carried away. Hence an effective coolant is used. The most common coolant for grinding operation is water in which some soda ash has been dissolved. There should be a copious flow of coolant at the work-wheel interface. The coolant also washes away the ground chips and swarf. The coolant must not have lubricant in it, otherwise, it may lead to glazing of wheels.

QUESTIONS

1. What do you understand by grit, grade, bond and structure of a grinding wheel?
2. Justify the popular adage that hard wheels should be used for soft material and vice-versa.
3. Describe the cylindrical grinding operation. Give an idea of the grinding wheel and work speeds recommended for this operation.
4. Describe the surface grinding operations with disc as well as cup type wheel.

Welding Process

CLASSIFICATION

Welding means the process of joining two metal parts together to give a sound and strong joint. The welding process is subdivided into two main classes.

1. **Fusion welding**, which involves heating the ends of metal pieces to be joined to a temperature high enough to cause them to melt or fuse and then allowing the joint to cool. This process is somewhat similar to casting process. The joint, after the fused metal has solidified will result in a strong joint.

2. **Pressure welding**, which involves heating the ends of metal pieces to be joined to a high temperature, but lower than their melting point and then keeping the metal pieces joined together under pressure for sometime. This results in the pieces welding together to produce a strong joint.

There are many subclassifications of welding under each head. Subclassification is done according to the source of heat required for fusion or pressure welding. We shall deal with but three of them (a) Gas welding (b) Electric arc welding, and (c) Electric resistance welding.

GAS WELDING PROCESS

In this process, the heat source is combustion of acetylene gas. Chemical reaction of acetylene and oxygen produces a great deal of heat and the oxyacetylene flame burns with temperature exceeding 3250°C, enough to melt most metals and alloys. Two systems are in vogue for oxyacetylene welding:

(i) **High pressure system:** In this system, both oxygen and acetylene gases are drawn from cylinders in which these gases are stored at high pressure.

(ii) **Low pressure system:** In this system, oxygen gas is drawn from a cylinder as before, but acetylene gas is produced at site at low pressure. Acetylene gas is produced in a sealed container in which water falls drop by drop on calcium carbide. This acetylene gas is drawn for oxyacetylene welding as per requirement.

EQUIPMENT NEEDED FOR GAS WELDING

High pressure oxyacetylene welding equipment consists of two large steel cylinders. One which is conventionally painted black and is a long thin cylinder contains oxygen filled in at a high pressure of 125–140 kg/sq. cm. The other cylinder which is painted maroon and is shorter but of slightly larger diameter contains acetylene gas dissolved in acetone at a pressure of 16–21 kg/sq. cm. One should handle the D.A. cylinder with great care as acetylene is an inflammable gas and this cylinder should be kept vertical, as far as possible. Both these cylinders are fitted with valves which are normally kept in “closed position”. D.A. means dissolved acetylene gas.

In order to draw gas from the cylinder, each cylinder is fitted with a pressure regulator with two gauges. The function of the pressure regulator is to reduce the pressure of the gas before delivering it. The two gauges indicate the pressure inside the cylinder and the reduced pressure of gas after the pressure regulator stage. The gases are carried from the pressure regulator to the welding torch (also called blow pipe) by means of rubber hose pipes. The pressure regulator and the hose pipe connected to oxygen cylinder are of black colour while those connected to acetylene cylinder are of maroon colour, so that there is no mix up.

A welding torch consists of different passages for oxygen and acetylene gases. Supply of these gases is controlled by pin valves. These two gases are then allowed to mix in a mixing chamber before being driven out through the orifice of the blow pipe. These orifices are of different sizes and can be screwed on to the blow pipe. The complete assembly of the cylinders, regulator etc. is shown in Fig. 6.1. Normally the two cylinders are carried in a trolley, which is not shown in Fig. 6.1.

A gas welding operator uses the following safety apparel:

- (i) Wears blue coloured goggles to protect his eyes,
- (ii) Wears a leather or canvas apron to protect his person,
- (iii) Wears leather gloves to protect his hands.

He carries metal welding rods and a supply of flux. He also carries a chipping hammer, a wire brush and a spark lighter. The procedure of lighting a flame is to open the pin valve controlling the flow of acetylene gas in the welding torch and to use spark lighter to burn the gas. The acetylene gas burns with lot of smoke. The oxygen supply valve is then opened and adjusted to get the desired kind of flame.

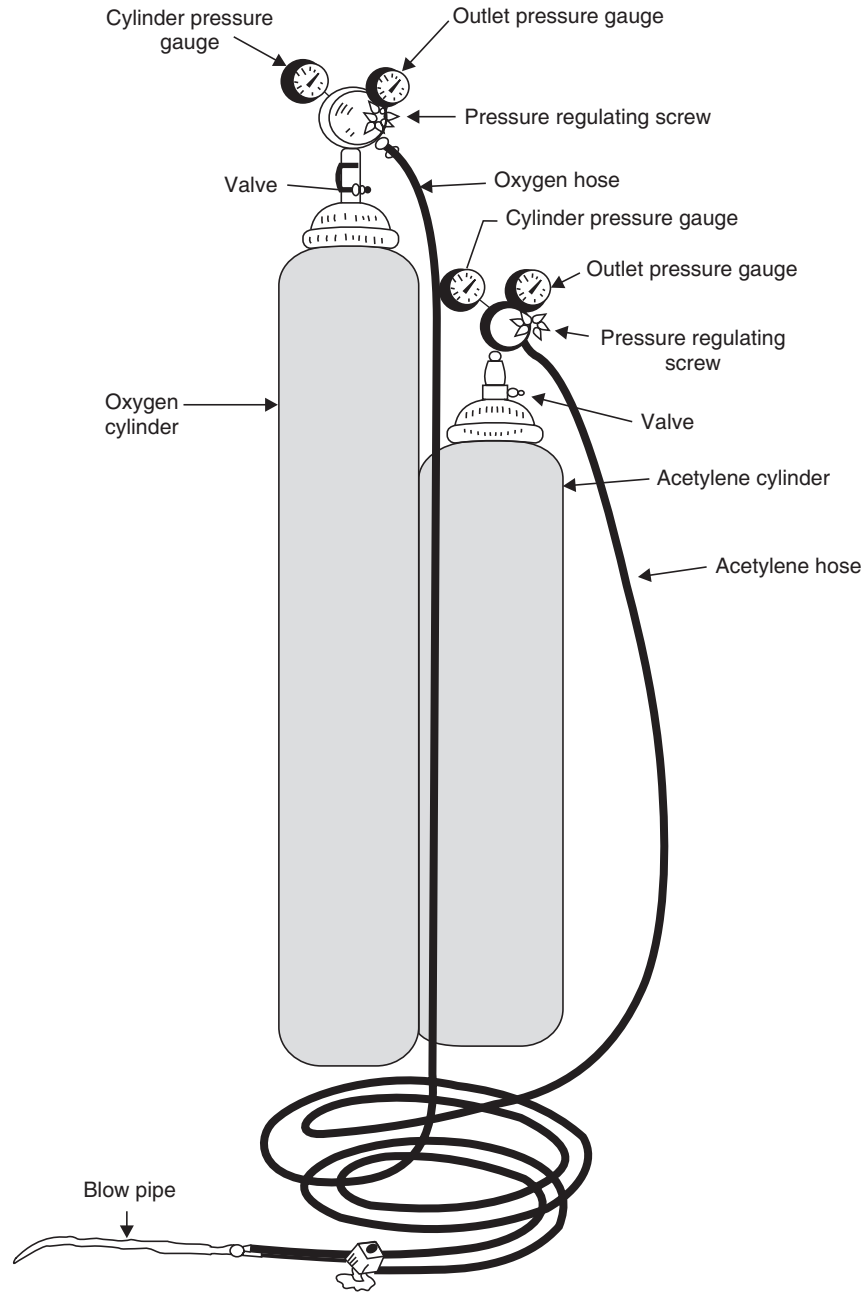

Fig. 6.1 High pressure welding equipment

TYPES OF FLAMES

Three kinds of oxyacetylene flames can be produced with the gas welding equipment. The chemical reaction between acetylene gas and oxygen is represented by the equation



For complete combustion of one volume of acetylene, $2\frac{1}{2}$ volumes of oxygen gas is required. Out of $2\frac{1}{2}$ volumes of oxygen, one volume is drawn from the cylinder and $1\frac{1}{2}$ volume, is supplied by the atmosphere, when the flame burns. When the oxygen is supplied in this proportion, the flame is called neutral flame. If however, oxygen supply is less, the flame is termed reducing flame as it contains some unburnt carbon. If there is excess supply of air (*i.e.*, oxygen), the flame becomes oxidising flame. These three kind of flames can be distinguished from each other by careful observation. These flames are shown in Fig. 6.2.

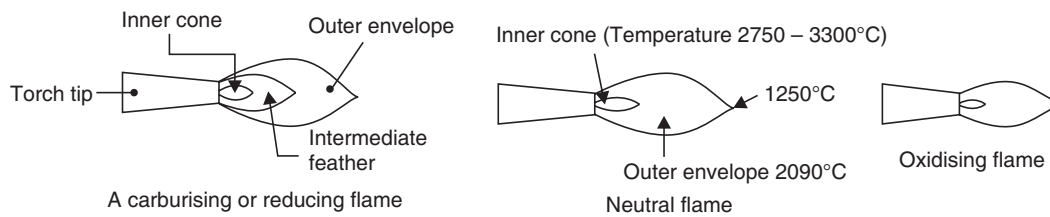

Fig. 6.2 Types of oxyacetylene flames

A carburising or reducing flame has three distinct zones—inner cone, intermediate feather and outer envelope. When oxygen supply is increased the intermediate feather gradually disappears and only two cones are left the inner cone and the outer envelope. At this point the acetylene and oxygen gases are in chemical balance and the flame is neutral flame. If the supply of oxygen is further increased, the inner cone reduces in length, loses its shape and a sharp hissing sound is produced. The flame has now become oxidising. Such flames have highest flame temperature.

Neutral flame is used for welding of all kinds of steel and cast iron products. Slightly oxidising flame is used for welding brass, bronze and copper products or for welding chromium-Ni and manganese steels. Slightly carburising flame is used in welding of high carbon steel, aluminium and Nickel products.

WELDING OPERATION

Setting of the job: Parts to be welded are cleaned and the joint prepared. Joint preparation depends upon the thickness of work pieces. Thin sheets can be joined by an edge or flange-joint. Sometimes, a lap or fillet joint can be used. A sheet of higher thickness but not exceeding 4.5 mm may be welded with a butt joint without any joint preparation. Different kind of joints commonly used in welding are illustrated in Fig. 6.3.

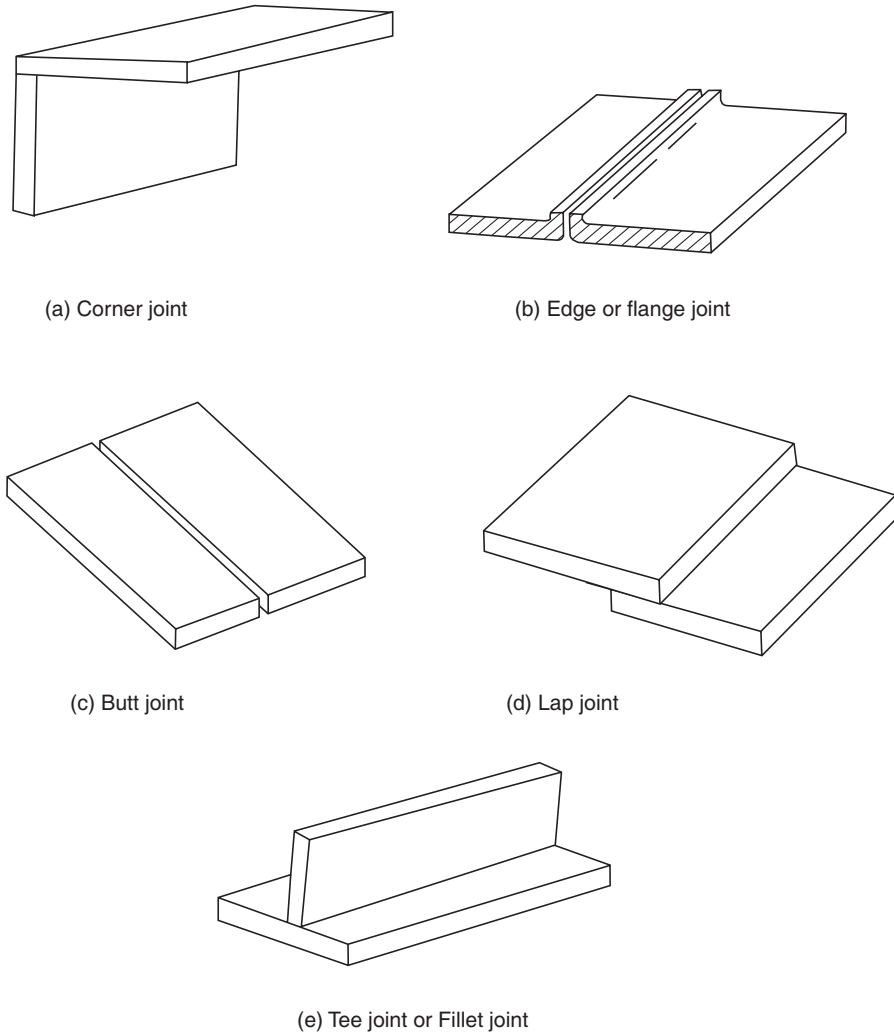

Fig. 6.3 Different types of joints

For sound welding of plates thicker than 4.5 mm, detailed joint preparation is needed. The edges of the two plates to be welded are bevelled resulting in formation of V-shaped groove between them. The edges of the two plates are not allowed to touch each other, instead they are separated by a gap of about 2–3 mm. If plates are thicker still, instead of a single V-joint, a double V-joint is resorted to. A single V and a double V-joint is shown in Fig. 6.4.

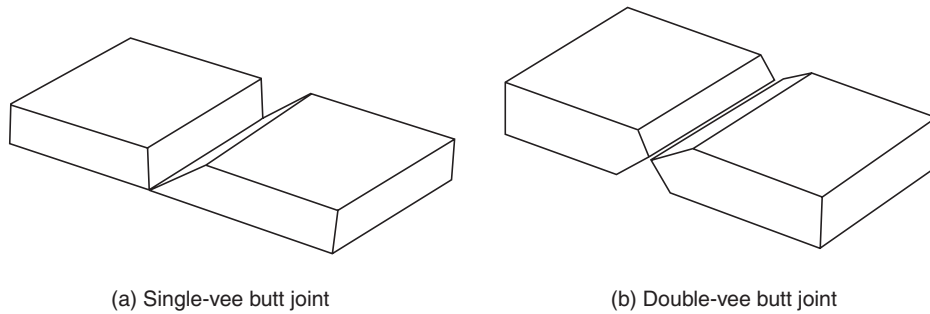

Fig. 6.4 V groove joints

Gas welding techniques are classified as:

1. Left ward welding or forehand welding technique, and
2. Right ward or backhand welding technique.

The position of welding torch, filler rod and direction of welding for these techniques is shown in Fig. 6.5.

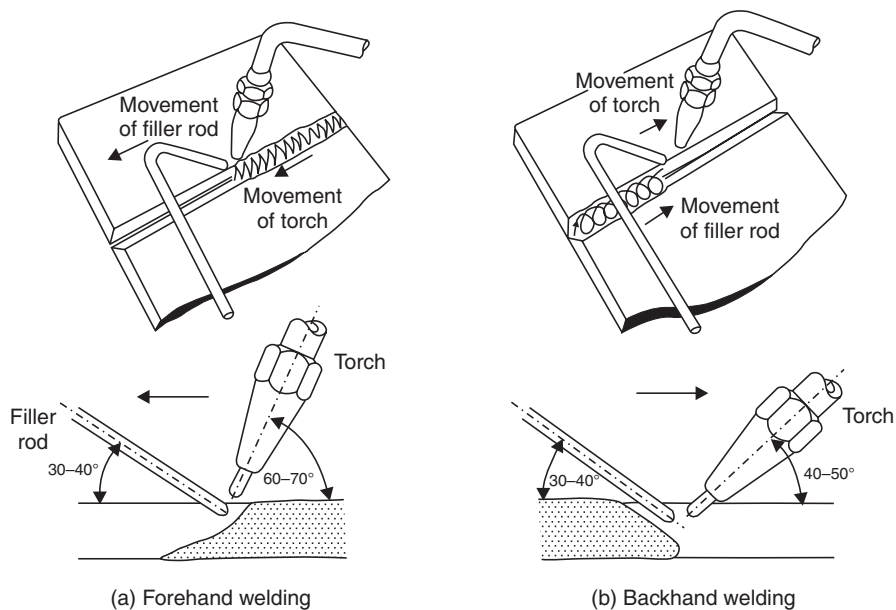

Fig. 6.5 Welding techniques

It will be noticed that in the left ward welding technique, the flame from the torch preheats the material yet to be welded, whereas in the right ward welding, the flame postheats the weld-bead. This has certain metallurgical significance.

USE OF FILLER RODS AND FLUXES

Whenever, welding is done, some extra metal may have to be added to the molten metal pool. In gas welding, the extra metal comes from filler rods, the ends of which keep getting melted. Ideally, the composition of filler rod should be identical with the metal of the work piece.

During the process of welding, some metal may get oxidised. Flux is used to dissolve and remove these metal oxides. Flux like borax or a mixture of fluorides and chlorides of sodium, potassium and lithium are most commonly used. The flux reacts with metallic oxides to yield slag, which being lighter floats on top of molten metal pool. After solidification, the welder removes the flux using a chipping hammer and wire brush.

OXYACETYLENE CUTTING

The oxyacetylene flame can also be used for cutting a steel plate. This is done through a special “cutting torch”, which has an extra passage for high pressure oxygen in addition to the usual two passages for oxygen and acetylene gas.

The process of oxycutting (or flame cutting) is essentially an oxidation process. The place, where a cut is to be made is heated with the welding flame and when it is red hot, high pressure oxygen is allowed to impinge on it. Steel is oxidised and the iron oxides having a lower m.p., melt easily. The jet of oxygen blows away the molten iron oxides exposing further layer of steel. This in turn gets oxidised and soon the steel plate gets cut throughout its thickness. The oxyacetylene flame is slowly moved. In this manner, any profile may be cut from the steel plate.

There is one limitation in this process. The cut has to start either from the edge of the steel plate or a pilot hole has to be drilled in the plate from which the cut can start.

ARC WELDING

In arc welding, the source of heat is an electric arc. The temperatures reached in an electric arc may be as high as 5500°C. A spark is produced in an electric circuit carrying current, if the circuit is broken accidentally. An electric arc is a sustained spark created intentionally by a gap between welding electrode and the work piece. Because of larger heat output and less oxidation, the quality of weld produced by electric arc is much better than gas-weld.

Either A.C. or D.C. power supply may be used for arc welding. For A.C., a transformer type machine is used to supply current. For A.C., an open circuit voltage of about 75–80 V is required. The current requirement is however very heavy and the welding machine should be capable of delivering 100–300 Amperes.

D.C. supply is characterised by the +ve and –ve terminals. With D.C., a slightly lesser open circuit voltage of 70–75 volts will be adequate to strike the arc. Normally the electrode is connected to –ve terminal and the work piece to +ve terminal. Such an arrangement is called D.C. straight polarity (DCSP). In this arrangement about 2/3rd of the heat is produced on the work piece end and 1/3rd at the electrode end. Under certain circumstances like overhead welding, D.C. reverse polarity (DCRP) arrangement is preferred. In this arrangement, the electrode is connected to +ve terminal and the workpiece to –ve terminal.

The process of electric arc welding with coated metal electrode is shown in Fig. 6.6.

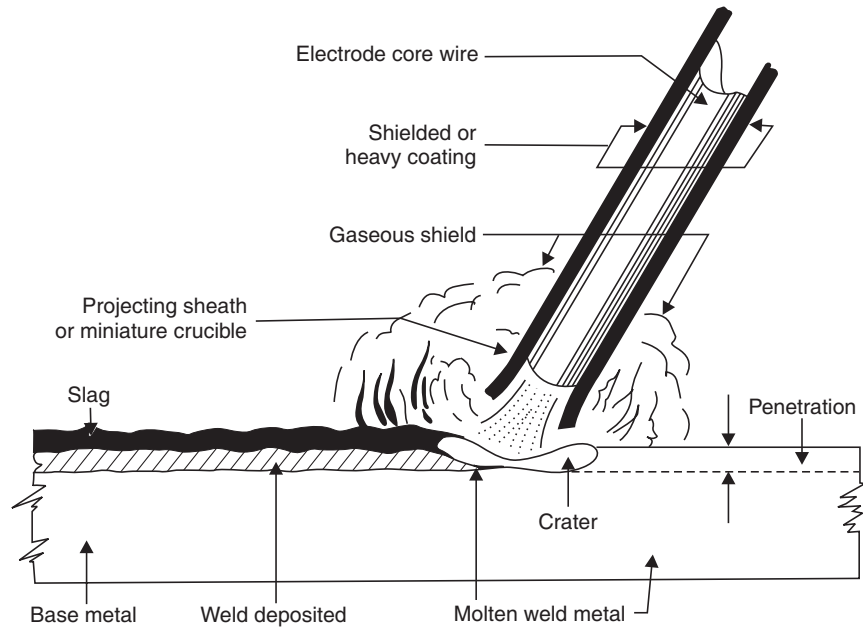

Fig. 6.6 Welding action of a cellulosic-coated stick electrode

STRIKING AN ARC

To strike an arc, the electrode should be shorted by touching the work. At the moment of contact, a very heavy current starts flowing through the circuit, while voltage drops. Now, the electrode is lifted slowly so that a gap of 2–3 mm between the tip of the electrode and the work piece is maintained. The voltage across the arc rises to about 15–20 volts and the amperage drops. Due to heat generated in the arc, the tip of the metal electrode starts melting and the gap increases. Unless the electrode is slowly moved towards the work at the same rate at which the tip of the electrode is melting maintaining the gap at 2–3 mm, the arc will extinguish. If the gap increases too much the machine voltage will not be able to maintain the arc.

A great amount of heat (and intense light) is generated by the arc. It not only melts the electrode tip, but also melts the work piece at the location of the arc maintaining a pool of molten metal as shown in Fig. 6.6. Without some manner of shielding, this metal will oxidise. The metal electrodes are therefore, given a layer of coating throughout its length (except for about 35–40 mm at the stub end, where the metal core of electrode is exposed and held in the electrode holder). Under the action of heat, this coating at the tip of the electrode vaporises and creates a gaseous shield around the molten metal pool and saves it from oxidation. The electrode coating also contains flux (which reacts with impurities to form slag) and other ingredients which help stabilise the arc. Many types of coatings are in use.

As the electrode is slowly moved over the joint, the molten metal pool solidifies creating a joint. The joints produced by this process are often stronger than the parent metals being joined.

Electrodes are available in many sizes. The size of electrode is specified by the diameter (in mm) of the core metal wire. Size of electrode depends upon the thickness of parts to be joined. Thicker electrodes are required to weld thick plates. The current depends upon the size of electrode used. Thus for a 3.15 mm dia electrodes, the recommended value of current is 100–120 Amp.

HEAT AFFECTED ZONE

In the arc welding process, a great amount of heat output takes place resulting in formation of a molten pool in the arc area. The heat is also conducted into the vicinity of the joint on either side. The temperature of the material on both sides of the weld bead may not be as high as the melting point of the metal, but, is very close to it. As we move away from the joint or weld bead, the metal may be heated to lesser and lesser temperature. As the electrode travels over the joint and moves away, the heated metal cools as quickly as it was heated. Thus, we can conclude, that the metal adjacent to the weld bead has been subjected to a heat treatment. If steel is being welded, this heating and quick cooling may result in formation of martensitic and other structures which may be prone to cracking and hardness.

The area so affected by welding is called “heat affected zone”.

ARC BLOW

A difficulty associated with D.C. welding is arc blow. Arc blow means that arc is deflecting from its intended path making the job of welding difficult due to shifting of arc. We know that when a conductor carries D.C., a magnetic field is set up whose strength is proportional to the value of the current. In D.C. welding, heavy currents are passing through the electrode and the magnetic fields set up deflect the arc to one side or another. This phenomenon is called arc blow and it becomes particularly serious, when welding is being done at the start of the metal pieces or at their end.

The ways in which arc blow may be reduced are:

1. Switch over to A.C. welding, if possible. Changing polarity of A.C. does not cause arc blow.
2. Reduce current, as practicable,
3. Use as short an arc as possible, and
4. Wrap the ground cable around the work piece several times.

WELDING POSITIONS

These are four welding positions from the point of view of the welder. These affect execution of sound welding.

These positions are:

1. **Downhand welding position:** This is the most comfortable position for welder to work in and he is able to produce welds of a good quality.
2. Horizontal welding position (on a vertical surface).
3. Vertical welding position (on a vertical surface).

4. **Overhead welding position (say on the ceiling of a room):** This is the most difficult welding position. Not only the operator has to crane his neck upwards and raise his arm to maintain arc, it is also difficult as molten metal tends to fall down due to gravity.

For important jobs, manipulators are used, which are capable of turning over the jobs and as much welding is done in down hand welding position as possible.

ARC WELDING DEFECTS

Improper welding procedure and lack of skill on the part of welder may result in many welding defects. The major welding defects are described below:

(i) **Incomplete fusion and lack of penetration:** Incomplete fusion can be avoided by proper weld joint preparation, using adequate current and travel speed of electrode should not be too high.

(ii) **Porosity:** Molten metal has a tendency to absorb gases. The entrapped gases cause porosity or blow holes in the weld bead. Remedy lies in cleaning the work piece surface of all oil, grease and paint etc. before welding and ensuring that electrode coating is free from dampness. If necessary, electrodes can be dried in an oven before use.

(iii) **Slag inclusion:** It refers to slag or other non-metallic inclusions getting entrapped in the weld bead. The most common reason for slag inclusion is that between two electrode runs, the slag, has not been completely removed by chipping and wirebrushing.

(iv) **Undercut:** Undercutting is often caused due to high amperage used. It denotes the melting away of the base metal at the line where the final layer of weld bead merges into the surface of the base metal. The undercut portion must be rectified by depositing weld metal on it.

(v) **Cracking:** Cracks can take place either in the weld bead itself (called hot cracks) or in the heat affected zone (cold cracks). Hot cracks may take place due to narrow deep welds and are caused due to shrinkage of weld metal, particularly if impurities like sulphur are present in the weld metal. Excessive joint restraint can also cause such cracks. Cold cracks occur due to inadequate ductility or presence of hydrogen in hardenable steels. Preheating and post heating of base material will help in avoiding cold cracks.

ELECTRIC RESISTANCE WELDING

In electric resistance welding (ERW) methods, a high current is passed through the metal pieces to be joined together and the heat is produced due to the resistance in the electric circuit. This heat energy is utilized to increase the temperature of a localised spot of the work pieces to produce coalescence, and then applying pressure at this spot till welding takes place. Electric resistance welding process is a pressure welding process and not a fusion welding process. The output of heat, in this process can be easily calculated. Heat generated is proportional to $I^2R \cdot t$, where I is value of current, R is resistance and t is the time during which current flows.

The following ERW processes are in vogue:

1. Spot welding process,
2. Seam welding process,

3. Butt welding process, and
4. Flash butt welding process.

1. Spot Welding Process

Spot welding process is shown in Fig. 6.7.

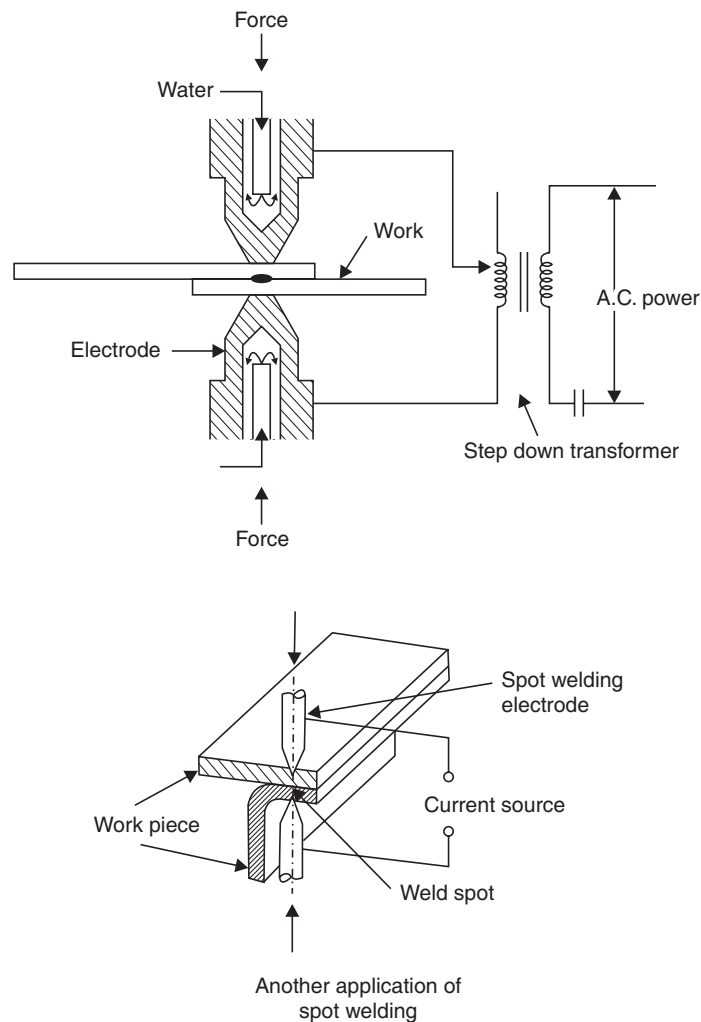

Fig. 6.7 Spot welding process

Spot welding consists of joining two pieces by placing them between two electrodes and passing a heavy current through them for a very short duration. This causes the material just below the electrodes to heat up quickly due to the intervening resistance to the flow of electric current. When coalescence temperature is reached, the current is switched off and a pressure is applied on the two electrodes. The pressure is released when the spot weld cools off. The portion of the material just below the electrodes

gets pressure welded. The weld joint is usually in the form of a round spot (if the electrodes have circular tips), hence the name spot weld.

The electrodes are usually made of copper and are water cooled. One of them may be fixed and the other one is movable. Normally A.C. power is used along with a step down transformer. The two terminals of secondary winding of transformer are connected to the two copper electrodes to complete the circuit.

Usually spot welding (as also other ERW machines) are automatic and work on the following weld cycle:

1. Squeeze the two metal pieces together with a light pressure.
2. Pass heavy electric current for a very brief time to obtain coalescence temperature,
3. Apply pressure and hold for sometime.
4. Remove pressure.

The whole cycle takes just a few seconds. Welding current may heat up the spot in less than a second.

This process is extremely suitable for mass production work and is extensively used for fabrication of automobile bodies, railway coaches, steel furniture etc.

One variation of spot welding process is called “Projection welding” process. In this process, at least one metal part has projections or depressions (made by some previous pressing operation). The other part and these projections contact each other. If welding is required to be done at these projected locations, an arrangement of electrodes such as shown in Fig. 6.8 may be used.

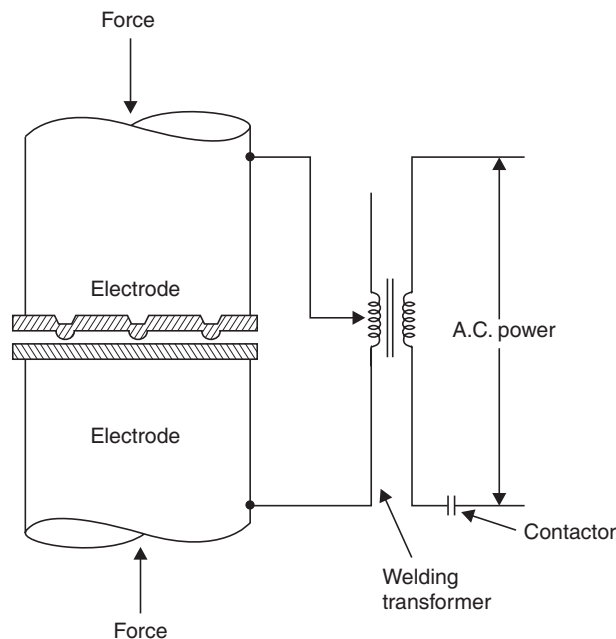

Fig. 6.8 Projection welding

The weld cycle remains same and on passing current all projections will heat up and get welded. Projections need not be round; they can be of any shape. Projection welding is extremely suited for massproduction work, where a number of spot welds are required close to one another.

2. Seam Welding Process

A seam is produced by overlapping spot welds. The seam welding machine is, therefore, similar to a spot welding machine. But in the seam welding machine, the electrodes are in the form of copper rollers. The two work pieces which are to be joined pass between the rollers. The rollers exert a pressure on the work piece and also rotates the same time. This helps in automatic feeding of the work pieces. The rollers are connected to the secondary winding of transformer but the current passed through the rollers is a pulsed or intermittent one. This results in a successive series of spot welds being made. If the spot welds are overlapping, a seam weld is created.

By seam welding, a leak proof joint is made.

3. Butt Welding Process

Welding two pieces of metal together, end to end, is called butt welding. In butt welding the ends are cleaned and made square so that the two pieces touch each other over the entire cross-section. One piece is held in stationary clamps (Refer to Fig. 6.9) and the other piece in movable clamp.

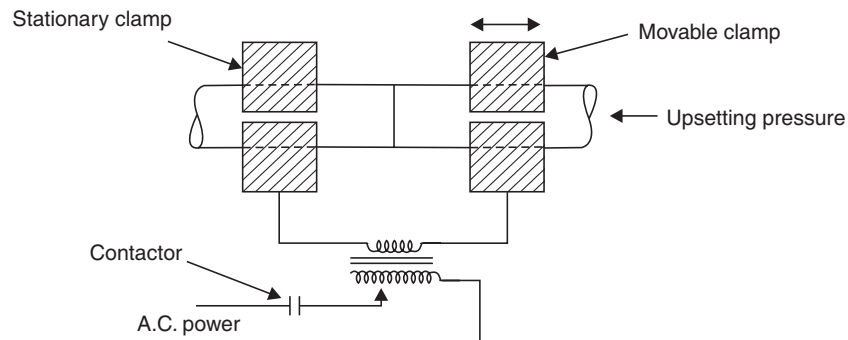

Fig. 6.9 Butt welding (ERW)

The movable clamps bring the two pieces to be welded together end to end. Then the current is switched on heating the ends quickly. Then the movable be clamps close in with pressure and hold the two pieces together under pressure until the butt weld is made. Obviously, the material around the joint upsets and has to be cut and thrown away.

4. Flash Butt Welding Process

In this process, the end preparation is not so detailed as in upset butt welding process described above and the ends need not be dead square. In this case, the current is switched on before bringing the two ends to be welded, close together. This results in flashing as the two ends almost touch each other but have a little gap between them. This flashing or arcing generates heat and the two metal end heat up to coalescence temperature. Current is then switched off and the two ends are brought together under

pressure to complete the pressure weld. In this case also, a little upsetting of material around the joint surface will take place which may be get rid off by grinding.

SOLDERING AND BRAZING

Soldering and brazing are allied joining processes. The main difference between welding on one hand and soldering and brazing on the other is that, in either soldering or in brazing process, the temperatures used are not high enough to cause melting of parent metals to be joined. The difference in soldering and brazing is again based on temperature considerations. In soldering temperatures up to 427°C are used and in brazing process, temperatures above 427°C are employed. Strengthwise soldered joints are weakest, while welded joints are strongest. Brazing produces joints with intermediate strength.

SOLDERING PROCESS

Soldering is a process of joining two metal pieces by means of a low temperature fusible alloy called solder applied in molten state. Solders are alloys of low melting point metals like lead, tin, cadmium and zinc. Of these tin-lead alloys are most common and are called soft-solders. A combination of 62% lead and 38% tin produces the lowest melting point and is called 60–40 solder. This corresponds to the eutectic composition of Pb–Sn series and has a fixed m.p. of 183°C. Increasing tin content produces better wetting and flow qualities. Hard solders are also available and have higher melting points.

Before applying solder, the surfaces to be joined are cleaned and a flux like ammonium chloride is used. Then the solder is melted and spread upon one surface, while the other surface is applied to it under pressure. When the solder solidifies, the two pieces get joined. The process of soldering does not call for any joint preparation. A common example of soldering can be seen in joining electrical wires of P.C.B. circuits.

BRAZING PROCESS

Brazing is a process of joining metals with a non-ferrous filler material. The filler material has a melting point above 427°C but below the melting point of the parent metals to be joined. The filler material is called “spelter” in case of brazing and it must wet the surfaces to be joined.

In brazing, the joint has to be carefully designed and joint prepared with due care. When spelter is molten, it flows into the joint clearances by capillary action and fills up all vacant spaces. Since higher temperatures are involved in brazing, a light alloying action at the surface layers of parent metal takes place. This lends considerable strength to the brazed joints.

Brazing may be done with the help of oxyacetylene brazing torch, or the heat may be produced by induction/eddy currents. Sometimes electric furnaces are also used.

Common brazing filler materials are silver, copper, copper-zinc, copper phosphorous, aluminium silicon and copper-gold alloys. These alloys are available as wires, rods, preformed rings and in powder form. Brazing temperatures usually range from 427°–1200°C. Fluxes commonly used are borax, fluorides and chlorides of potassium, sodium and lithium.

Most common example of brazing can be seen in brazing of H.S.S. and tungsten carbide tipped tools.

QUESTIONS

1. Describe the principle of oxyacetylene gas welding. How many types of flames are used for welding?
2. Distinguish between welding, brazing and soldering. Which process produces the strongest joints and why?
3. Describe the arc welding process. What role does electrode coating play in producing a satisfactory weld?
4. Distinguish between fusion and pressure welding processes.
5. What is arc blow? How can it be avoided?
6. Describe the principle of spot welding with the help of a neat diagram.
7. Differentiate between butt weld (plain) and flash butt ERW welding processes.
8. What is heat affected zone? What is its importance in producing a crack free weld?
9. Describe some common welding defects.
10. Write a brief note about welding positions.

Objective Type Questions

UNIT III MACHINING AND WELDING AND ITS APPLICATIONS

Pick out the most appropriate option:

1. What is 'swing' of a centre lathe?
(a) It is the length of the bed (b) It denotes the diameter of the job being machined
(c) It is the length of cross slide movement (d) None of these.
2. Cutting speed for turning on a lathe depends upon
(a) the material of work piece
(b) the tool material
(c) whether or not cutting fluid is being used
(d) all of these.
3. What is the difference between right hand and left hand turning operations?
(a) Right hand turning is done by a right handed operator
(b) Right hand turning means that the cross slide is moved forward
(c) When turning is done from right to left and left to right respectively
(d) Right hand turning means when job is supported on the right end by tailstock.
4. Cutting tools are made of
(a) tungsten carbide (b) chromium carbide
(c) nickel nitride (d) none of these.
5. Function of cutting fluid in machining is to
(a) keep the tool cool
(b) lubricate the cutting point
(c) assist in chip removal by flowing them away
(d) all of these.

6. A shaper cannot produce
(a) a horizontal plane surface (b) a vertical plane surface
(c) an inclined vertical surface (d) a cylindrical surface.
7. Which gases are used in gas welding process?
(a) Oxygen and hydrogen (b) Acetylene and oxygen
(c) Acetylene and LPG (d) Helium and oxygen.
8. Low pressure OAW is the name given to the welding process in which
(a) oxygen is supplied at low pressure (b) acetylene is supplied at low pressure
(c) both oxygen and acetylene are supplied at low pressure.
9. In grinding wheels, which of the following abrasives are used?
(a) Silicon oxide (b) Aluminium oxide
(c) Cubic boron nitride.
10. Cutting speed in milling operation is given by πDN , where N and D indicate
(a) RPM and dia of the work piece
(b) RPM and dia of milling cutter
(c) RPM of milling cutter and dia of work piece
(d) RPM of work piece and dia of milling cutter.

Indicate, if following statements are True or False:

11. The lips in a twist drill are also known as cutting edges.
12. Cutting tools are usually made of H.S.S.
13. Soldering is carried out at temperatures above 427°C.
14. In brazing, the parent metals fuse under the action of heat.
15. In pressure welding, welding is done under the action of heat and pressure.
16. Arc welding requires only direct current supply.
17. Function of electrode coating is to protect the core of electrode from rusting.
18. A slotting machine is used for sheet metal work.
19. A twist drill can be used to enlarge a hole.
20. Boring is the process of enlarging a hole.

ANSWERS

- | | | | | |
|--------|--------|--------|--------|---------|
| 1. (d) | 2. (d) | 3. (c) | 4. (a) | 5. (d) |
| 6. (d) | 7. (b) | 8. (b) | 9. (b) | 10. (b) |
| 11. T | 12. T | 13. F | 14. F | 15. T |
| 16. F | 17. F | 18. F | 19. F | 20. T |

**This page
intentionally left
blank**

UNIT IV

Miscellaneous Topics

**This page
intentionally left
blank**

Importance of Materials and Manufacturing

INTRODUCTION

We all know how important a role materials play in our daily lives. From the house, in which we live (which requires bricks, mortar, cement, steel, wood, plastic, brass taps, glass and other materials to build), modern man cannot do without a host of these and other materials. The cooking vessels are made of stainless steel with copper bottoms, pressure cookers are of aluminium with a rubber gasket, cutlery is made from silver covered brass, and the plates from which we eat our food are made of ceramic materials. This list could go on and on; because man requires an endless array of materials; and the choice of materials available today is also very wide.

PROPER SELECTION OF MATERIAL

Though the list of materials from which a material may be selected for a particular application is very long, only one or two materials may fulfill the criteria for selection. The selected material should meet:

- (i) Service requirements,
- (ii) Fabrication or manufacturing requirements, and
- (iii) Economic requirements.

Service requirements: For the component to give successful service, it must have suitable mechanical properties like strength, hardness, impact strength, rigidity, specific gravity etc. In addition, it should also have the desired electrical, magnetic, optical and thermal properties. It must have suitable corrosion, fatigue and creep resistance. All these factors narrow the choice of a suitable material.

Pure metals normally cannot fulfill all these requirements. Alloys offer a much greater choice and their properties could be altered by changing their composition or by suitable heat treatment. Here the role of synthetic material (material created by man) also offers a choice in selecting a suitable material.

Manufacturing requirements: A component has definite shape and size. The material selected should be capable of being cast or worked to the required shape and size. If the tolerances or surface

finish demand that the material may be finish machined, it should be possible to do so. Sometimes, weldability of material is a major requirement. The material selected should meet all the requirements of manufacturing.

Economic requirements: Finally, the component has to pass the criterion of cost. The raw material and the manufacturing cost should not be prohibitive, otherwise there will be no demand for the component or that item.

The above are some considerations which govern the selection of material for a specific job.

IMPORTANCE OF MATERIALS

The most revealing insight about the importance of material is brought home by studying prehistory. *i.e.* the progress of mankind before the era of recorded history. This prehistorical period is divided into following five ages on the basis of the materials which the mankind had learnt to use:

- (i) Old stone age (paleolithic age),
- (ii) New stone age (neolithic age),
- (iii) Copper age,
- (iv) Bronze age, and
- (v) Iron age.

In the old stone age, man employed stone for making rough tools for his use. He would chip off small stone pieces from granite or flint rocks and select suitably shaped pieces with sharp edges for use as knives or scrapers. He was also familiar with use of bones and animal hides. In the new stone age, man learnt to make polished stone tools, and sharpening their edges by rubbing them against other rocks.

Gradually, man became familiar with noble metals like gold and silver probably because they were found in nature in native (that is in pure form) state. He used them for jewellery and decorative purposes, but being soft, such metals could not be used to make tools. In ancient Egypt, beautiful funerary masks of gold were buried along with “mummies”.

Next important discovery by man was of copper. Melting point of copper is 1083°C and that of its ores lower still. Man must have discovered copper by sheer accident as bonfires must have been lit and a lump of copper ore must have got reduced to copper. With discovery of copper, man could now make axes and other tools of copper. The “mummy” of a hunter, who fell into an alpine ditch between the borders of modern Italy and Austria some 5 to 6 thousand years ago (but did not decompose being buried in snow) was found recently. Among his possessions, a copper axe was found in almost pristine condition. In India, in the vedic text, copper has been treated as a sacred metal, the implements/vessels used to perform a ‘Yagna’ are of copper.

Bronze was the next metallic alloy to be discovered, again by sheer accident. This time the ore contained copper as well as some tin. Bronze is much harder and stronger than copper and soon tools as well as weapons were fashioned out of bronze instead of copper. Tribes having access to bronze weapons could subjugate others who did not possess bronze weaponry.

Iron was the last to be discovered, because the high melting point of iron needed a very effective furnace which could generate temperature of 1500–1600°C. The discovery of iron is generally attributed to the race of Hittites, who lived in what is today called Asia Minor. Hittites kept the secret of making

iron to themselves (members of tribe were warned on the pain of death not to divulge this secret to others). With swords made of iron, they could cut the weapons of their enemies. Hittites defeated even the powerful Egyptian army.

The above brief description should convey to the reader the importance of materials in no uncertain terms. The fate of kingdoms depended upon their knowledge of materials and metallurgy in the same way as today, power of nations comes from their possession of nuclear weapons.

HISTORICAL PERSPECTIVE

If one looks at the history of human civilization it is noticed that there have been primarily three revolutions which have contributed significantly in improvement of the life style of society. The three revolutions are (i) 'Agriculture' revolution (ii) 'Industrial' revolution (iii) 'Electronics and Computer' revolution. Thousands of years ago, people were nomads moving from place to place. Some how they learned to grow crops which itself was, in a way, revolution. Agriculture ultimately forced people to live near their fields/crops and that lead to formation of society, village, town and city. Though agriculture-revolution occurred thousands of years ago, however, it could not further improve the life style of the society. It was the industrial revolution which began in England 200–250 years ago which gave real, significant and substantial a impetus to the improvement of socioeconomic development of individual, society and nation. Appreciation for industrial revolution automatically comes out, if one imagines life without electricity, vehicles or modern day to day amenities to which we are used to now. Life style has further improved and changed through modern-age electronics and computer revolution. Though the impact of modern electronics/computer is more visible in developed countries but it is making its impact in developing countries too. TV, computer and mobile phones have penetrated into every corner of the world. What agriculture revolution could not achieve in a thousand years, industrial revolution did in a couple of centuries. Now electronic revolution is doing the same in decades only. The real technological revolutions are the industrial revolution and the electronic/computer revolution; though modern-age green revolution of mechanized-agriculture is no less technological.

MATERIALS AS DRIVING-FORCE BEHIND TECHNOLOGICAL DEVELOPMENTS

It is jokingly, but most probably rightly, said that behind every successful man there is a woman; similarly behind every technological revolution there must have been certain material(s). History reveals that the driving force behind a successful technological revolution has been some material. There would have been in fact (i) no industrial revolution without steel, and (ii) no electronics/computer revolution without semiconductor. What would be the material of the next technological development? If it is imagined that, there is a contest among the materials to be chosen for next revolution, then the nominees for such an award are: ceramics, plastics, composites, aluminium alloys and superconductors, as can be seen from the following:

- (i) Ceramics, which had been usually considered quite unimportant and suitable only for manufacture of ceramic-jar, wash-basin and toilet-seat etc., now have changed completely. Ceramics have now found several new applications ranging from electronics industry to aero-space industry. Variety of ceramics, including glass have been developed which find numerous applications.

- (ii) Plastic seems to be the strongest contestant. Slowly but surely, plastic products are seeping into our house and finding more and more applications in every walk of our life. Some people make a hue and cry regarding environmental problems, but mostly these are baseless, as most of the plastics can be recycled and reprocessed. Moreover, history tells that ‘no one can stop the progress of science and technological development; it comes into our life and is accepted in due course of time after initial hesitation’. Plastic is such a scientific development, and plastic products are replacing almost everything around us— be it ceramic (glass), wood, fabric or even iron and steel. It is said that gold is the metal for kings and iron is the king of metals. Iron and gold have grown old. The new king seems to be the non metal, that is Plastic; and the new king’s regime is wide ranging from bath-room to the operation-theatre. Plastics come in large variety of varying properties ranging from soft-polythene to strong-Teflon. Light-weight, availability in various shapes and colours at low-cost are its added advantages. If there is any environmental problem, it can be solved.
- (iii) Composites are also coming in a big way and find applications ranging from a badminton racket to automobile and aircraft industries. The base materials for the light weight composites are plastics (polymers) in which high strength fibres are used as reinforcement.
- (iv) When aluminium was first discovered and extracted chemically, it was costlier than gold; Napoleon used gold-cutlery everyday but aluminium-cutlery on special occasions only. Mass production of aluminium through electrolysis-process, brought its cost down drastically. Though usually materials affect the technological development, this is an example how technology can influence the material and its cost. However, aluminium-alloys were found to be much better than aluminium itself in many ways. Various aluminium-alloys find numerous applications ranging from cold drink cans to aircraft body and engines. For example, duralumin is such a material which is almost as strong as steel but light as aluminium. Thus aluminium is also a contestant.
- (v) One of the strong contestants for the award of material for next technological revolution is superconductor. Superconductor was discovered in 1911 when it was found that mercury is superconductor (*i.e.* resistance is zero) at extremely low temperature of about 4°K (– 269°C). Since then various other (better) superconductors have been found up to critical temperature $T_c = 150^\circ\text{K}$ which is still much below room temperature. Superconductors find many applications ranging from electrical and electronic applications to super-magnets for magnetically levitated trains. One such application of superconductor is Josephson Junction (JJ) which works as high speed switching device, which can increase the computer speed a thousand times. Problem is that of the T_c . Efforts are on, for the search of room-temperature high T_c superconductors; and if such a search succeeds, then this can bring about a real revolution. Interestingly, such a high T_c superconductor is likely to come from a class of ceramics which are non-conductors.

Manufacturing as the Master-Key for Socioeconomic Development

The million dollar question is ‘where and how wealth can be produced. Printing money by reserve-bank does not produce wealth. It only devalues the currency. Someone may say that God has already

produced wealth in form of oil, gold, diamond and minerals which are hidden beneath the ground. That is true; but the said question refers to human beings. In fact, money (wealth and profit) can be produced in only two places: (i) Farms (through agriculture) and (ii) Factories (through manufacture). In both cases, there are certain inputs which after-transformation lead to the desired output. This transformation adds to the value, and the difference in value of output and input is the wealth created.

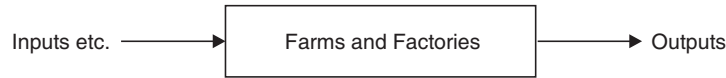

Fig. 1.1 Farms and Factories as Job-creator and Generator of wealth (output–input)

<i>Input</i>	<i>Output</i>	<i>Place</i>	<i>Process</i>	<i>Technological Revolution</i>
• Seeds etc.	Crops	Farms	Agriculture	Agriculture revolution
• Raw materials	Products (Mechanical/Electrical)	Factories	Manufacturing	Industrial revolution
• Raw materials	Products (Electronics/Computer)	Factories	Manufacturing	Industrial revolution extended to electronics and computer

Wealth is generated, though in less amount, through agriculture wherein variety of crops can be grown to yield money. But agriculture depends on so many natural factors that its success becomes uncertain. Pure agriculture is less profitable, but agriculture based industries are quite profitable.

More value is added through manufacturing in factories. It is said that in America, 97% land is used for agriculture and only 3% for industry. The return to national income is just the reverse, *i.e.*, 3% and 97% respectively. A simple calculation shows that about 1000 times more money is produced in industry than in agriculture. That is why, industrialists are richer and farmers are poor, specially in India. The present-day industrial revolution is the electronics and computer revolution which is yielding even more profit.

The most important revolution is the industrial revolution (which includes the present-day electronics and computer revolution) through ‘manufacturing’. Historically, industrial revolution started in England. It generated wealth which accelerated the pace of it. But it needed a market to sell the products. This resulted in the desire for colonization of, say, Africa and India. In fact, colonization was a result of industrialization. The prosperity of England as compared to other European countries, was inherent reason for jealousy and rivalry between them. The jealousy and rivalry finally resulted in the World-Wars. In modern age, however, the industrialists and governments want economic-colonization in place of real physical colonization. Global scenario of multinationals ventures and outsourcing across countries are a few examples of this doctrine.

For industrial development, the basic infrastructure facilities such as transportation and communication are a must. Moreover, steel industries are said to be the base industry for other industries to grow. Steel and electricity consumption have been considered as yardsticks of socioeconomic development. Bismarck famously said ‘for development of a Nation, you don’t need lectures and meetings, but you need blood (enthusiasm) and steel’, the reason being that steel is the basic material for machines which do manufacturing.

DIRECT AND INDIRECT LINKAGES AMONG MATERIALS, MANUFACTURING, TECHNOLOGICAL DEVELOPMENT AND SOCIOECONOMIC IMPROVEMENT

Technological development *directly* depends upon certain material *e.g.*, steel for industrial revolution, and semiconductor for electronic and computer revolution. Socioeconomic development *directly* depends upon manufacturing; examples are manufacturing in the era of industrial revolution (including the current era of electronic and computer revolution); as the manufacturing, which is not only the wealth-creator but job-creator also, leads to socioeconomic improvement in many ways. There are *indirect* dependencies among these too, as shown in the block diagram. The *inverse*-dependence, *inter*-dependence and *cross*-dependence all are indirect dependence, shown in Fig. 1.2 with dashed-lines in horizontal, vertical and diagonal-directions respectively. The example of inverse-dependence is that technological development such as nano-technology can lead to newer (nano) materials and products. The example of inter-dependence is that the technological progress such as in bio-technology can lead to socioeconomic development and improvement. The example of cross-dependence is that the technology development via new technology can lead to better manufacturing (such as micro-miniaturization manufacturing of electronic chips through new technological developments). Examples for other lines of dependence can also be traced easily, but this is left to readers to think upon and find out. In nutshell, all the four things viz., materials, manufacturing, technological development and socio-economic development are interlinked or related to each other in one way or the other either directly or indirectly.

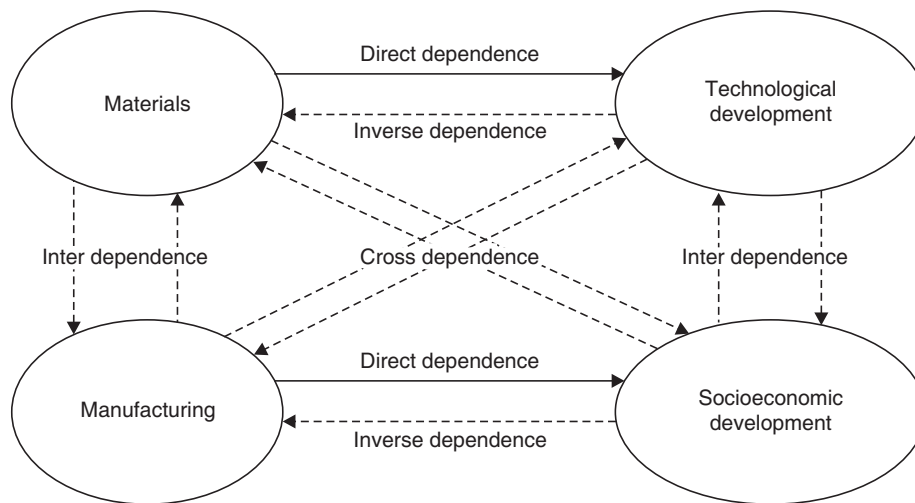

Fig. 1.2 Diagram showing the Direct dependence and the various Indirect dependences (Inverse, Inter and Cross) among Materials, Manufacturing, Technological and Socio-economic Development

CONCLUSION

For 'socioeconomic development' of society and nation, manufacturing is most important. Manufacturing is not only a wealth-generator but a job-creator too. Better, up-to-date and competitive manufacturing

is possible with the 'technological development', wherein 'materials', play an important role. In fact all the four elements discussed: (i) Materials, (ii) Manufacturing, (iii) Technological Development and (iv) Socioeconomic Development are interlinked to each other in one way or the other. Emphasis should be on 'materials' and 'manufacturing', which are the driving force and the key for success of 'technological' and 'socioeconomic' development. In the current scenario of advancement, globalisation and competitiveness, these have become even more important.

QUESTIONS

1. What role has been played by materials in raising the standard of living of mankind?
2. What are the main factors in choosing a material for a particular application?
3. Write a note about importance of manufacturing in modern society.

Location and Layout of Plants, Production and Productivity

INTRODUCTION

The standard of living of mankind depends upon efficient manufacture of goods. Efficiently manufacture implies that the cost of manufacture of an article should be as low as possible, so that many people can afford to buy it. Cost of manufacture per unit also reduces, if there is a large demand for the item in question. Such considerations have led to modern manufacturing philosophy of 'mass production', which is organised in a large workshops or plants. Such workshops employ a large number of suitably trained workers, and the workshops themselves are located at convenient locations in order that goods may be manufactured as efficiently and as cheaply as possible.

LOCATION OF PLANTS

What factors should be considered in choosing a suitable or convenient location for a workshop or plant? Some important factors are:

1. Adequate land should be cheaply available. The area should be free from water logging and flooding and should not be in an earthquake-prone zone. Provision should include land for any possible future expansion also.
2. Enough rail and road transport should be available, so that the transport of incoming raw material and outgoing finished products is not a problem.
3. Enough power and water should be available in the area.
4. Markets for the finished products should be available nearby. It is for this reason that lot of industry comes up near metro cities.
5. Enough skilled manpower should be available locally. Availability of residential, schooling and health facilities will help in retaining manpower employed in the plant.
6. If the plant is located near a developed industrial area, maintenance of plant becomes relatively easy.
7. The chosen location of the plant should be such that getting environmental clearances is not difficult.
8. Availability of raw material—Steel Mills are always located near iron ore and coal mining areas.

LAYOUT OF PLANTS

It is not sufficient to choose a proper location for the plant. Lots of machinery and other production facilities are provided in a plant. If such machines and facilities are not provided with planning and foresight, there will be lot of criss-cross movement of semiprocessed material. The production will not go on smoothly and cost will go up.

Plant refers to the factory or production facility as a whole. A large plant must be divided into departments or “shops”. A simple example of a “food processing plant” (say a pickle manufacturing company) will be considered here. The plant will have a receiving department, where the raw materials (like mangoes, lemons etc.) will be received in bulk, weighed and stored before being sent to the “cleaning” department or shop. In this department, the incoming material may be washed, graded and dried. Next the washed and dried mangoes, lemons etc., may be sent to “machine department/shop”, when the fruit may be peeled, sliced, squeezed etc. There will be, of course, several more departments or shops.

Plant layout refers to a systematic and functional arrangement of different departments, plant and machinery provided so that the production takes place most efficiently with economy of cost and time. It includes interconnecting roads and material handling inside a plant as well as water and power supply arrangements etc.

ADVANTAGES OF A GOOD LAYOUT

1. Material movement is simplified, orderly and is reduced to a minimum. It helps in reducing “inventory”.
2. There is smooth and orderly flow of the product through various stages of manufacture.
3. Effective utilisation of space is achieved. Provision of extra space is a costly proposition.
4. Layout provides for inherent safety of workers and boosts their morale.
5. It provides for effective supervision.

TYPES OF LAYOUTS

Basically, there are three types of layout. They are:

- (i) Process or functional layout,
- (ii) Line or product layout, and
- (iii) Combination or group layout.

In process or functional layout, all similar machines or operations are grouped together. For example, in a machine shop, all shaper, big and small will be installed at one side, all milling machines on another side and all lathes separately in another corner etc.

In product or line layout, the machines are provided in the sequence, in which the product is to be processed. If milling is the first operation, a milling machine will be installed first, if shaping is the second operation required, then next to the milling machine, a shaper will be installed and so on. In this scheme of things, the raw material is taken in at one end of the line and the furnished product, after undergoing several operations in specified sequence comes out at the other end of the line.

It is clear that in process type of layout fewer machines will be required. If one machine is under repair, work can be done on another machine. This flexibility is not available in line layout. Breakdown of a single machine in the line will jeopardise the functioning of the entire line. Supervision is easy in process layout but the quantity of material under process at anytime is more. In process layout, more time cycle is required to complete the product. Several other advantages and disadvantages could be cited in favour of each kind of layout.

Combination layout was evolved as a mixture of the above two types of layouts, so that the advantages in the line and process layouts could be maximised and disadvantages reduced to a minimum. Most of the modern day industries adopt a combination or group layout.

Sometimes, when a very large product like a ocean going ship or a Boeing Aircraft is manufactured, it is not practical to shift the product from place to place which would be required if either a functional, line or a combination layout were adopted. Hence, in such cases, the product remains at one fixed location and all operations are carried out at that location. Such type of working is called a fixed location layout.

TYPES OF PRODUCTION

Depending upon the scale of production and the kind of product, the production can be classified as:

1. Piece or job lot production,
2. Batch or medium size production, and
3. Mass (or bulk) production.

This classification is important, because depending upon the scale of production, different manufacturing strategies are adopted by plant managers for efficient production.

1. **Piece or job lot production:** Here the parts are produced in small quantities and repeat orders are not likely. Therefore, the plant does not invest in buying any special kind of machinery. The work is managed with general purpose machines only and as far as possible, standard tools are used. The workers have to be more skilled as they have to tackle different kinds of jobs from day to day. Typical examples are parts required for maintenance of machinery and replacement of wornout parts. These are one off requirements.

2. **Batch production:** Here the orders are for small quantity only but orders are repeated again after an interval of time. Machinery and plant used is general purpose type only, but greater use of jigs and fixtures is made to reduce cycle-time and ensure accuracy of parts. Some common examples of this type of production are—printing of books, production of machine tools, pumps, compressors etc.

3. **Mass production:** Here very large quantities of products have to be manufactured month after month. The quantity may be 100,000 a year or more. Common examples are manufacture of sewing machines, scooters, cycles, cars, electric switches, electric fans etc.

Here the manufactures relies upon specialised machinery to cut down manufacturing time, use of special gadgets etc. The management normally resorts to a line or product type of layout for the plant and relies upon semi skilled or even unskilled labour to do the job, as most jobs are repetitive in nature. Even robots are used in plants to perform repetitive jobs.

PRODUCTION AND PRODUCTIVITY

Production and productivity are two different words with different meaning. Production refers to quantity of production while productivity means the efficient use of resources consumed for achieving that production. Resources are of several types—material, men, machine hours, energy consumed, space utilised etc. Lesser is the consumption of such resources per unit of production, higher is the productivity. Let us take the example of two motor cycle manufacturers who produce similar motorbikes—same design, same HP etc. If one manufacturer uses 1.5 tonnes of steel per motorcycle and the other uses 1.4 tonnes of steel, the latter's material productivity is higher. Productivity should not be confused with cost of manufacture, although a plant with higher productivity will use less resources and its product is likely to be cheaper. Another example will make the difference between production and productivity clear. If one steel maker uses 6 tonnes of coke per tonne of steel produced, its productivity is higher as compared to another steel maker who uses 6.8 tonnes of coke per tonne of steel produced. The fact that the first steel maker produces only 1.5 m.t. of steel per year, whereas the second steel maker produces 4.5 m.t. of steel per year is of no consequence, when we talk about productivity.

Productivity of plants or any other manufacturing activity is a very important concept. Recent growth of Japan is attributed to the high productivity levels achieved by their manufacturing concerns. Productivity alone will make the products competitive, production alone will not help a nation become great.

QUESTIONS

1. Differentiate between production and productivity. Why is productivity important? Can you suggest some indices for measurement of productivity?
2. What are the major considerations which should be taken into account for deciding a suitable location for a factory?
3. What are the different philosophies behind plant layout?

Non-Metallic Materials

COMMON TYPES AND USES OF WOOD

Wood is a natural material and, it has been used for diverse applications. It is said that Pataliputra, the capital of Magadh empire had a rampart made of wood. The famous Roman machine of war “the catapult” was made of wood. In olden times, ocean going vessels were made of cedar wood. In India, bullock-carts are still made of wood.

The source of wood is stem or trunk of a tree. A tree with trunk of adequate girth is felled and the main stem is cleared of all branches. The resulting log is sawn and converted into different commercial sizes (known as plank, board, batten, scantlings etc.). All wood must be “seasoned” before it is used. The object of seasoning is to remove sap from the wood and to stabilise its moisture content. If the excess moisture is not removed, the articles made of unseasoned wood will be subject to shrinkage and warping during service. Non removal of sap will attract termites and other bugs.

A properly converted and seasoned wood of good quality suitable for use in industry is called timber. Timber or wood is of two types (i) soft wood, and (ii) hard wood. This classification is based on the species of tree from which the wood has been taken. Usually, the evergreen trees (which grow in the hilly region in India) yield soft wood, while the wood extracted from deciduous-trees growing in tropical rain forest is hard wood. Examples of soft wood are chir (pine), blue pine (also called Kail), deodar, cyprus etc. Examples of hard wood are teak (local name: Sagwan, botanical name: *Tectona grandis*), mahogany, rosewood, andaman paduk, shisham, saal etc.

Soft wood is light in colour, light in weight, has a distinct resinous aroma and is easily worked. Very often, packing crates are made of this wood and fruit grown in hills is carted in these crates.

Hard wood is dense, heavy and dark in colour. It is stronger and much more durable than soft wood. It has no characteristic odour and cannot be easily worked. Its fibres are close and compact. This is the timber used in construction of furniture and door frames etc. Teak wood, by far, is considered the best hard wood. It can take high polish and retains its size and shape even after many years.

Wood can also have several defects. Timber selected for use should be free from knots, shakes (*i.e.* cracks) and fungus and should be free from insect attacks (like borer-holes).

Another classification of wood is possible. If the trunk of a tree is cut, the cross-section consists of two types of wood. The heart or central section of wood appears darker and more dense, while the

wood surroundings the central portion appears lighter in colour. As most trees grow outwards, the wood in the central portion of the stem, which is known as “Heart wood” is more mature and aged. The wood surrounding the heart wood is relatively new and less strong. This wood is called “Sapwood”. Heart wood yields better quality and stronger timber and should be used in preference to sapwood.

The strength of wood along its grains and across the grains is different.

USES OF WOOD

With cutting down of forests, wood has become very costly. This has restricted the use of wood. In modern times, wood is used in construction of houses, door and window frames. Furniture is made of wood. In industry, wood is extensively used for making patterns for castings, and as a packing material. Thick pieces of wood are also used along with screw jacks and other lifting tackles as packing. Wood is a bad conductor of electricity and this fact enhances its utility. Wooden sleepers are used in railway tracks.

Since good quality wood has become very costly, wood is often converted into plywood. Plywood is nothing but thin veneers or layers of wood glued together by adhesives in such a way that its strength is enhanced. The inner layers can be made from cheaper woods and only the outer layer, which will be visible, is made from high quality woods. Thus use of plywood becomes an economical proposition and has replaced use of solid wooden planks for table tops or door frames etc. Wooden articles have to be protected by giving them a thin coat of varnish or paint.

CEMENT CONCRETE

Everyone is familiar with cement. Cement is a material used for bonding solids. Two main types of cements are in use. These are Portland cement and high alumina cement. The cement used in civil engineering construction is called Portland cement or Simply cement. It is sold as a grey-green powder but has no fixed composition.

Cement is made by pulverising together certain raw materials. A typical composition of the raw feed from which cement is prepared is given below:

SiO ₂	15–16%
CaO	42% as CaCO ₃ (limestone)
MgO	2.5% as MgCO ₃
Al ₂ O ₃	2.5%
Fe ₂ O ₃	2%

The percentage will not add up to 100%, because CaO and MgO are added as CaCO₃ and MgCO₃ in the form of rocks mined in stone quarries. All the above material is ground to 200 mesh size in a pulverising mill and then it is heated in a kiln either in dry condition or in the form of a slurry. After burning in the kiln, the clinker (*i.e.* the residue after burning) is ground to a very fine powder (about 325 mesh size) and blended with up to 5% Gypsum (CaSO₄). Then it is bagged in standard 50 kg bags.

Portland cement sets when mixed with water. It is actually a hydrated calcium silicate and calcium aluminate.

Cement concrete is prepared by mixing cement powder with water, sand and aggregates (stone pieces, pebbles etc.) in the proportion recommended. Usually about three fourth of the total volume is made up of aggregates and sand. The mixture is thoroughly mixed in a mechanically rotated drum called concrete-mixer. Cement concrete delivered by the concrete mixer should be used without delay. It sets in about 24 hours into a hardened mass, although the process of complete curing takes about a week. During this period, some water should be sprinkled on the surface of the cement concrete mass everyday to keep it for drying completely.

Cement concrete is economical to use. It has got good compressive strength (about 28 MPa) but is poor in tensile strength (2–3 MPa) hence when used in construction of buildings (for beams, pillars and roofs), it should be reinforced by using steel rods. It is then called reinforced cement concrete or R.C.C. If cement concrete is used in road construction or construction of runways etc. in airports, no reinforcement is necessary. R.C. concrete is very durable and fire resistant. It is almost maintenance free. Bond between steel and cement is also good.

CERAMICS

The word “ceramics” is derived from the Greek word “Keramos”, which means “burnt material”. Ceramics are inorganic non-metallic materials which have undergone or will have to undergo during service very high temperatures. Ceramics include a wide variety of materials with which the reader is already familiar. The list includes glass, chinaware, enamels, cement, refractories, abrasives, electrical porcelain insulators, electronic ceramics etc.

The nature of chemical bond in ceramics is “ionic” in nature and anions affect the property of ceramics. Some anions which are important part of ceramics are carbides, borides, nitrides and oxides.

Properties of ceramics: Ceramics are very hard and brittle. They can withstand compressive forces to some extent but are poor in tension. Being hard, they are abrasive or wear resistant, they are also heat resistant (*i.e.*, refractory) and are corrosion and acid resistant. They are chemically inert even at high temperatures.

Some common types of ceramics are:

(i) Glass, (ii) chinaclay products, (iii) refractories like fire clay, magnesite etc., (iv) abrasives like silicon carbide, Al_2O_3 , (v) cements, (vi) cutting tool material like tungsten carbide, CBN and (vii) advanced ceramics.

Ceramics are used in missile and rocket technology. Alumina ceramics are used for missile and rocket nose cones. Enriched uranium dioxide, a ceramic material is used as nuclear fuel. Laser beam is produced by a specially doped single crystal or ruby. Piezo-electric crystals like barium-titanate are made up of ceramic material. Some of the new advanced ceramics are being used in protection systems for military jawans and military vehicles against ballastic projectiles.

RUBBERS

According to American Society for Testing Materials (ASTM), rubber (elastomer) is a polymeric material, which at room temperature, can be stretched to at least twice its original length and will quickly return to its original length when the stretching force is withdrawn.

Plastics are also polymeric material, but rubbers are different from them on account of this property of stretching to this extent and returning to original length. Rubbers are both “natural” and “synthetic”. Natural rubber oozes out as a milky liquid if a cut is made on the stem of a rubber tree. Until World War II, almost all rubber used was natural rubber. During that war, synthetic elastomers were developed due to the scarcity of natural rubber. Synthetic rubbers have better properties than natural rubber and are widely used now.

Natural rubber is soft and has poor resistance to abrasion. Its properties can be improved by “vulcanizing”. Vulcanization consists of heating 100 parts of natural rubber with 1 to 5 parts of sulphur by weight. Vulcanization improves the modulus of elasticity, tensile strength and resistance to oxidation of natural rubber. It also hardens the rubber and makes it useful for industrial application. Useful temperature range of natural rubber is 10–60°C, the same for vulcanized rubber is – 40 to 100°C. The tensile strength improves from 70 kg/cm² to 700 kg/cm². Vulcanized natural rubber is used in manufacture of tyres, tubes, rubber soles of shoes and gaskets. Apart from sulphur, other additives are also added to rubbers to improve their properties or to develop a specific property. Automobiles tyres contain about 15–30% by volume of carbon black.

Characteristics of Rubbers

The rubbers are noncrystalline. They are poor conductors of heat. They are non conductors of electricity. They have relatively low softening temperatures. They have high resistance to oily, chemical and corrosive atmospheres. However they show signs of ageing showing hardness and cracks and a lowering of properties. They have good vibration damping characteristics.

Synthetic Rubbers. Main synthetic rubbers used in industry are described below briefly:

(1) **Neoprene:** It is the first commercial synthetic rubber which was developed in 1930. Generally its properties are similar to that of natural rubber, but in compression particularly in elevated temperature conditions, it is superior to natural rubber. However it has excellent weathering and heat resistance, good oil resistance, excellent flame resistance but its dielectric strength is lower than that of natural rubber.

Its main uses are for manufacturing heavy duty conveyer belting, V-belts, hoses and gaskets.

(2) **Butyl rubber:** It is also similar to natural rubber. It however is not costly. It shows high resistance to abrasion, tearing and flexing. It has low gas and air permeability. It have good weathering resistance and good chemical resistance. It has very good dielectric strength.

Their main application is for cable insulation, high pressure steam hoses, machinery mounting pads and suspension bushes.

(3) **Nitrile rubber:** Main property is excellent oil resistance whether oil is vegetable or mineral oil. Typical application is for manufacture of gasoline, chemical and oil hoses, o-rings, seals, and sole of shoes.

(4) **Isoprene rubber:** It is more or less like natural rubber. But its good electrical properties and low moisture absorption make it a very good insulation material.

(5) **Silicone-rubber:** It has excellent resistance to high and low temperatures, although its mechanical strength is low. Silicone elastomers are one of the most stable elastomers and have high resistance to oils and chemicals.

Typical applications are for seals, gaskets, o-rings, insulation for wires and cables and tubing for food and medical uses.

PLASTICS

A plastic is an organic material which, at some stage in its existence is capable of flow and which, upon application of heat and pressure, can be made to flow and acquire the desired shape. This desired shape will be maintained even when heat and pressure are removed. Plastics are composed of long molecular chains which produce many of the properties the plastics have.

Plastics can be broadly classified into:

- (i) Thermoplastics, and (ii) Thermosetting plastics.

Thermoplastics: Plastics of this type can be softened by application of heat and pressure and reformed into another shape. This shape can be resoftened and converted into yet another shape. This process can go on indefinitely, provided the plastic material is not heated to too high a temperature causing decomposition of material.

The structure of a thermoplastic material is shown in Fig. 3.1.

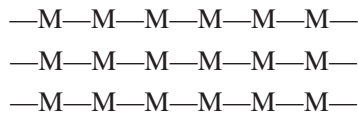

Fig. 3.1 A thermoplastic chain

M represents a molecule of a “monomer”. A monomer is a substance which has the ability to join up with other monomers to form a long chain. Formation of a long chain is effected by a process called polymerisation or condensation. In actual materials, these chains of monomers lie in a tangled state. Occasionally, the chain may consist of two or three different kinds of monomers. In this case, the first kind is called monomers and the other monomers in the chain are called copolymers.

Depending upon which particular monomer (M) forms the basic building block of a plastic (or polymer), a different plastic results and the resulting plastic is often named after that particular monomer—

e.g., polythene is based on the monomer “ethylene”; $\begin{array}{c} \text{H} \quad \text{H} \\ | \quad | \\ \text{C} = \text{C} \\ | \quad | \\ \text{H} \quad \text{H} \end{array}$ and is represented by the following chain

(ref. Fig. 3.2)

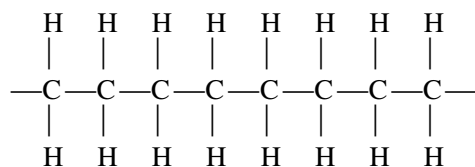

Fig. 3.2 Polythene chain

The rigidity of thermoplastic depends upon the structure of the basic material used and the other materials which are added to it during its processing. Plastics are never used alone. The basic plastic material like polythene is called “binder” and the materials which are added to the plastic are called “fillers”. Apart from these, some “colouring material” may be added to lend colour to the plastic. Lastly, but not the least, some “plasticiser” is also added; the plasticiser acts as an internal lubricant which helps the polymer chains to slide over each other and take up new positions under the action of heat and pressure.

Thermoplastics do not melt but flow at suitable temperatures and pressures and are available in the market as plates, thin sheets, tubing, rods and moulding materials. Thermoplastics can be processed by injection moulding, extrusion and blow-moulding techniques.

Thermosetting plastics: Thermosetting plastics undergo an irreversible chemical change when they are subjected to heat and pressure. Therefore, once an article has been made of thermosetting plastic, it cannot be recycled into another shape by applying heat and pressure. Since plastics are not biodegradable, thermosetting plastics offer an environmental challenge.

The structure of a thermosetting plastic is illustrated in Fig. 3.3.

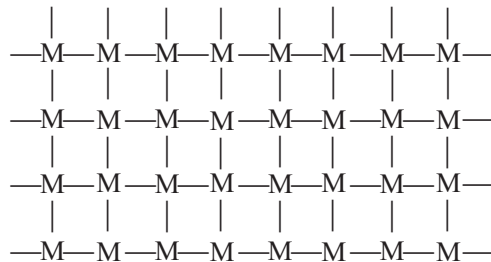

Fig. 3.3 Structure of a thermosetting plastic

In the above figure M represents a monomer as before. However, in thermosetting plastics, the long monomer chains, which lie tangled in a mass of material develop cross linkages between chains as heat and pressure is applied to it. The material therefore becomes rigid and chains are prevented from sliding past one another. The process of application of heat and pressure which develops cross linkages is called “curing” and once cured, the material cannot “flow” or change its shape again.

Thermosetting plastics are available as moulding powders, resins, or as paper or cloth impregnated with resin—all in uncured condition. As before, plastics contain, besides the basic material, a filler, colouring matter, a plasticiser and a hardening agent (to develop cross linkages on curing). Sometimes, an accelerator to speed up the curing process is also added.

Some common thermoplastics and their applications:

(i) **Polythene or polyethylene:** It is very common plastic made by polymerisation of ethylene. This material is available as low density polyethylene (L.D.P.E.), high density polyethylene (H.D.P.E.) and in high molecular weight variety. L.D.P.E. is used for making thin sheets, thin walled flexible tubing (such as used to water lawns), cable insulation and blown forms such as bottles etc. H.D.P.E. is more rigid and is used for making water storage tank (like syntex tanks), petrol and paraffin containers etc.



This polymer is used to make thin sheets, bottle like shapes and is a leather substitute. It is also used to provide insulation for electrical wiring, window curtain material, flooring material and toys.

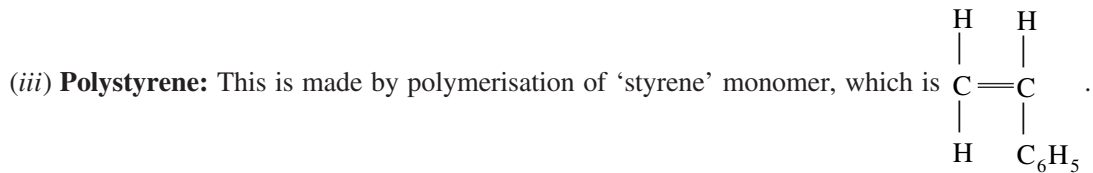

Polystyrene has excellent properties and optical clarity. It is used for wall tiles, indoor lighting panels, and toys.

(iv) **Polytetrafluoroethylene (P.T.F.E.):** If in polyethylene, all the hydrogen atoms are replaced

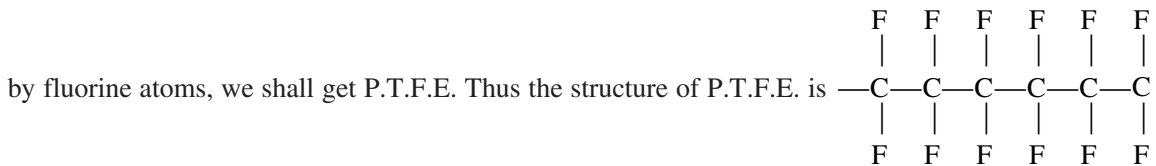

Polytetrafluoroethylene is non-inflamable and possesses good resistance against chemicals and solvents. But its most important property is its low friction. It is used for making bearing-bushes, ignition cable sheathing and acid plant gaskets.

(v) **Polymethyl methacrylate:** This material is available in sheetform, which are known as perspex. It has good light transmission and good weathering quality. It is therefore used as a replacement for glass and for making transparent enclosures.

(vi) **Polyamides (Nylon):** Nylon is used for making small gears and self-locking nuts. Nylon filament is used for brush bristles.

(vii) **Polyesters:** Polyesters are reaction products of acids and alcohols. They have good electrical insulation properties. Terylene, the most popular polyester is used as filament for making cloth in conjunction with cotton. It is used in capacitors, printed circuits, magnetic recording tape and ribbons.

Some common thermosetting plastics and their applications:

(i) **Phenolic plastics:** These are made from phenol and formaldehyde either in the form of a moulding powder or as a resin. By changing the procedure and the filler material, a range of phenolic plastics can be produced. It is relatively inexpensive and is sold under the name of bakelite. It is used for making telephones, automobile distributors and electrical fixtures.

(ii) **Aminoplastics:** Starting raw material for one type of amino plastics is urea formaldehyde. Thin walled articles such as cups and tumblers etc. are made out of the resulting plastic. Melamine formaldehyde is another aminoplastic which is used for making dinner plates and tableware.

(iii) **Epoxy resins:** (Trade name Araldite) have excellent combination of mechanical properties and corrosion resistance. It is dimensionally stable and has good electrical properties. It is used for adhesives, protective coating and is used for making laminates.

(iv) **Polyurethanes:** Polyurethanes are used as foam in cushions, arm rests and mattresses etc. It has all but replaced rubber foam.

(v) **Polyesters:** Polyesters can be produced both as thermoplastics and thermosetting plastics. Thermosetting polyesters have trade names like paraplex or laminac etc. It has excellent electrical properties and is cheap. It can also be fibre-reinforced and is used for helmets, fibreglass boats, chairs, fans etc.

COMPOSITE MATERIALS

Due to recent advances in technology, a demand has been felt for materials with extraordinary combination of properties. A material should have the strength of steel but lightness of magnesium. It should have hardness of tungsten carbide but should have toughness of steel. Obviously such combination of properties cannot be satisfied by ordinary materials available. This is specially true for materials needed for aerospace, marine and transportation industries.

Material scientists and engineers have found a way to solve this problem by devising composite materials. Consider Portland cement concrete with which we have already dealt with. It can be considered as aggregate composite whereas reinforced concrete can be regarded as a prototype of a composite material.

A composite material is often made up of two phases. One is called the matrix phase and the other is the dispersed phase. In reinforced cement concrete, cement concrete is the matrix and the steel rods which are used for reinforcement form the dispersed phase.

The matrix phase or the constituent is commonly a polymer material, whereas the reinforcing agents are carbon fibre, glass fibre or ceramics depending upon the properties which are required in the finished composite material.

Classification of Composite Materials

A simple method to classify composite material is shown in Fig. 3.4.

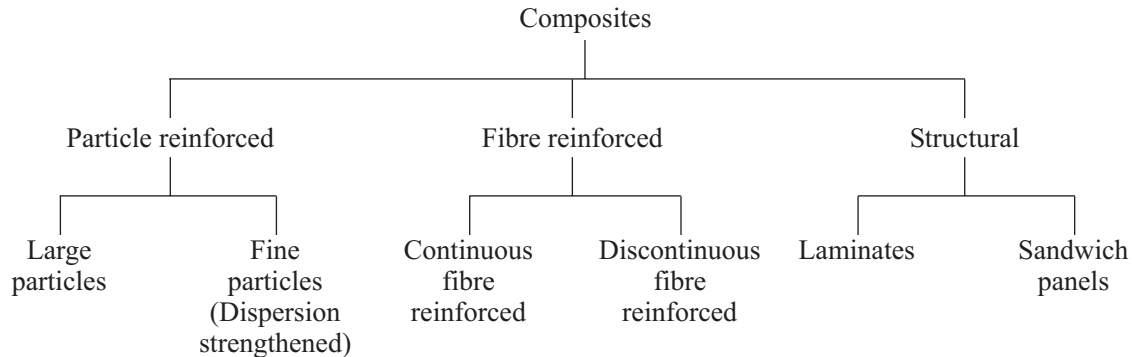

Fig. 3.4 Classification of composites

An example of particle reinforced composite is CERMET. One of the well known cermet contains extremely hard particles of tungsten carbide and titanium carbide embedded in a matrix of cobalt. The name cermet comes from a combination of words ceramic (WC) and metal (cobalt). This cermet is used as a cutting tool material.

Fibre reinforced composites are well known *e.g.* fibre glass. Fibre glass is a composite consisting of glass fibres laid in a matrix of a plastic material (resin). Glass is easily drawn into high strength fibres when in molten state. These glass fibres when used as reinforcement add strength to this composite. Sometimes in addition to glass fibres, carbon fibres are used, which are even stronger but stiff.

Fibre glass reinforced plastics are used in making small boats, car-bodies, acid containers/tanks, and specially papers. Carbon fibre composites are used to make tennis and badminton racquets, other sports equipment and light weight orthopaedic components.

An example of structural composites is sunmica or formica sheets which we use in house hold furniture and cabinets. Structural composite is made by using two dimensional sheets which are cemented together. While stacking the sheets together, it is ensured that the orientation of high strength direction (such as in aligned fibre-reinforced plastics) varies with each successive layer.

Very often, a protective coating which is hard and inert is given on the top surface of a structural composite so as to increase its service-life.

Advantages and Disadvantages

Composites provide exceptional strength to weight and stiffness to weight ratios. They can provide great heat resistance, improved fatigue resistance, improved toughness and reduced notch sensitivity. Composites are generally non-corrosive.

The main disadvantage is the high cost of composites.

QUESTIONS

1. Mention two important uses of wood in industry. Why cannot another material replace use of wood for these applications?
2. What is “composite material”? Why is the use of composite material increasing day by day?
3. Mention some important uses of rubber. Mention any four of its important properties.
4. What do you understand by “vulcanisation of rubber”? What are the different kinds of rubbers you know?
5. Write a brief note about “polymers”. How are plastics categorised?
6. What are “ceramics”? What are their properties?
7. What is “cement concrete”? How is R.C.C. different from cement concrete?

Miscellaneous Processes

POWDER METALLURGY PROCESS

Basic Process

In powder metallurgy process (PM), fine powders of metals and alloys are compacted together by pressing the powder in a mould or die to control the shape of the finished product. The pressure used for compaction are high so that the metal or alloy particles get mechanically interlocked. The part also develops enough strength, so that it may be taken out of the die or mould cavity without damage or crumbling back to powder form. The product of this compaction process is known as “green compact”. Its strength is low, and its density is below that of corresponding solid metal or alloy. It is also somewhat porous.

To produce useful strength level, the green compact is sintered at a high temperature but below the melting point of the powder-metal in a neutral or reducing atmosphere. An exchange of atoms between individual particles welds them together into a slightly porous piece of metal of the approx. shape and size of the die or mould cavity.

The sintered component may be used as such or may undergo some secondary operations before being used.

Now we shall discuss, in some detail, the various steps involved in making PM components:

1. **Metal powder production:** Metal powders can be produced in several ways of which atomisation is the most important. In this process, metal or alloy is heated until it melts. The molten metal is then gravity fed through a nozzle where it is impinged with a high velocity stream of water, air or nitrogen atomising it. Upon solidification, the atomised particles of metal or alloys are of various shapes and sizes. These may have to be pulverised to a fine powder of size below 100 microns.

2. **Blending:** Blending means agitation of powder for homogenizing the particle sizes. While blending some lubricants are also added so that during the next operation of compacting, the die wear and the friction between the metal particles may be reduced. Usual lubricants used are powdered graphite or lithium stearate. Blending is usually done dry—no water is added.

3. **Compacting:** After blending, the powders are placed in a die and compacted by pushing a punch in under pressure. The dies are usually made of tungsten carbide to reduce wear of the die. The

use of lubricants is necessary to reduce wear of dies and to reduce compacting force and in order that the density of “green compact” is almost as high as the density of solid metal. Ejection of green compact from the die also becomes easier with the use of lubricants. Compacting requires high pressures of the order of 700 MPa to cause mechanical interlocking in particles.

Before sintering, however, the lubricant must be driven out by a low temperature heating cycle.

4. **Sintering:** This is the next step in PM process. The green compacts are heated in a muffle type furnace in a controlled atmosphere. For ferrous metals, a dissociated ammonia atmosphere is used to control carburization or decarburization of the powder compact. Temperatures are maintained between 60–80% of the melting point of metal or alloy concerned. Sintering time may range from 20 minutes to 60 minutes.

Sintering raises the ultimate strength of the product. It results in diffusion bonding of particles.

5. **Secondary operations:** Many PM parts are used in as sintered condition. Others may require some secondary operations like infiltration, sizing, coining, impregnation or heat treatment before use.

The object of infiltration is to increase strength, density and hardness. It is done by placing a slug of copper alloy on top of PM parts during the sintering process. Copper alloy melts and infiltrates the small pores in PM part by capillary action.

In sizing and coining operations, the sintered part is repressed in the die to increase its strength and density by cold working. In addition the tolerance on the size becomes closer and the size of part becomes more accurate.

In impregnation, the sintered parts (if required) are impregnated with grease or oil by heating them to about 100°C in oil etc. for 10–15 minutes. Such oil or grease impregnated parts provide self lubricating properties.

PM parts can also be heat treated like wrought or cast metal parts to improve their grain-structure, strength and hardness.

Advantages of powder metallurgy process: The main advantage of PM process is that accurate control over powder can be exercised permitting variation in physical and mechanical properties. If so desired a part can be made with different densities in different portions of the same part. Parts can be made in different shapes accurately so that no subsequent machining is required. Small gears, parts with spline or irregular shapes can be produced cheaply and accurately. PM process is metal and energy efficient. PM parts are also relatively free from defects. Main disadvantage is that initial tooling costs are high and it cannot produce parts with weak thin sections.

PLASTIC PRODUCTS MANUFACTURING PROCESSES

Though there are a wide variety of plastic product manufacturing processes in use, the discussion of all of them is beyond the scope of this book. We shall describe three common methods. These are

- (i) Injection moulding,
- (ii) Extrusion, and
- (iii) Blow moulding.

Injection moulding: This is the method used for large scale production of thermoplastics components. The plastic powder is filled into a hopper connected to a cylinder-piston mechanism. As the piston withdraws, some plastic powder is inducted into the cylinder and the piston then moves it forward by exerting pressure on it. The cylinder is heated so that the plastic powder gets heated to a temperature between 175–275°C. Under the action of heat and pressure, the plastic softens and is forced through a nozzle into a water cooled die. Refer to Fig. 4.1.

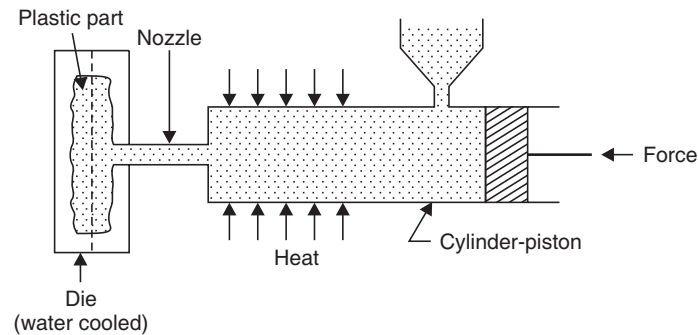

Fig. 4.1 Injection moulding of plastics

After the plastic part has cooled and solidified, it is ejected out of the die and the cycle starts all over again.

Extrusion: This process is also called extrusion moulding. This method is also suitable for thermoplastics, thermosetting plastics are generally not suitable for extrusion. By extrusion, solid rods, pipes, tubing and different sections can be made.

A hopper feeds polymer material into a chamber, which is kept heated. A screw rotates in the centre of this chamber feeding the polymer material forward. Under the action of heat and pressure, it starts flowing. In the front portion of the chamber, a (heated) die is fitted, which provides the only exit for the material. As more and more material is screw fed, a continuous stream of material is squeezed out from the die, its cross-section acquiring the shape of the die. The material coming out of the die is cooled and carried off by a suitable belt conveyer. The scheme of extrusion process is shown in Fig. 4.2.

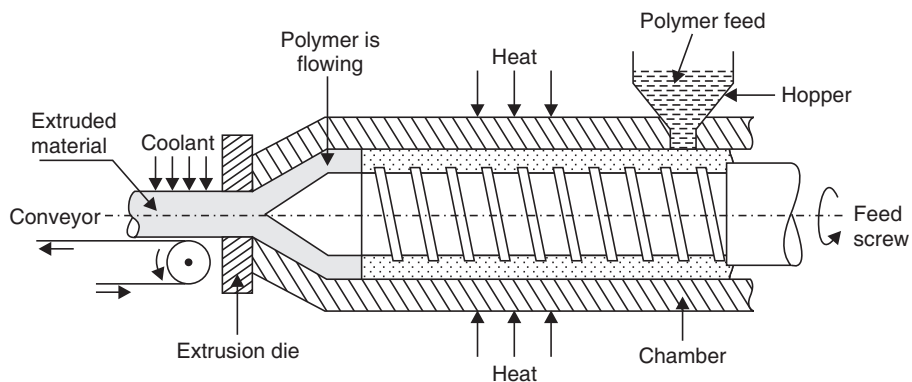

Fig. 4.2 Extrusion of plastics

Blow moulding: This process has been used for making plastic bottles, toys, hollow dolls and similar other items. The blow moulding begins with a heated tubular piece of plastic, which is called PARISON. The parison is positioned in between a two piece mould as shown in Fig. 4.3.

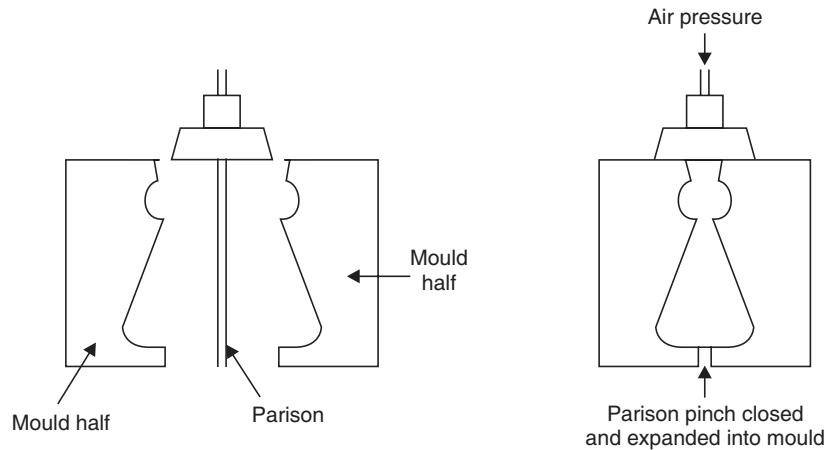

Fig. 4.3 Blow moulding process

The bottom opening of the parison gets pinch closed and sealed as the two piece mould closes. Air is then injected into the parison under pressure ($0.7\text{--}10\text{ kg/cm}^2$) thereby forcing the plastic to acquire the shape of the mould. The mould is opened and the part formed inside the mould is removed after it has cooled sufficiently.

The above process is similar to making articles of glass by blowing air into a mass of molten glass.

GALVANISING PROCESS

Galvanising is the name given to the process of coating steel sheets with a layer of zinc. The layer of zinc protects the steel item from corrosion and rusting by sacrificing itself. Over the years, when all zinc has been depleted due to atmospheric action, the steel surface will get exposed and begin to rust. Galvanised metal sheets, pipes and wires are used very extensively as the process of galvanising is a low cost process, but adds a lot of value to the item.

The main techniques for galvanising are:

- (i) Hot dip galvanising,
- (ii) Cold dip galvanising, and
- (iii) By electroplating.

Hot dip galvanising: The part to be galvanised is cleaned thoroughly. The idea is to remove all grease, paint, rust and dirt etc. from the surface. If a steel sheet is to be galvanised, the sheet is annealed and cooled in an oxygen free atmosphere. When it has cooled sufficiently, it is dipped into a bath of molten zinc. The sheet is then drawn through two rollers, when all excess zinc is removed from the surface and the zinc layer becomes uniform in thickness.

Cold dip galvanising: Cold dip galvanising process is cheaper but more time consuming. The first step is thorough cleaning of surface as in hot dip galvanising. Then the part or sheet to be galvanised is made to hang in a cold zinc bath consisting of zinc chloride, tin chloride and some other salts. The parts remain dipped or suspended in cold bath for 3 to 12 hours depending upon thickness of coating required. Bath, however has to be periodically stirred.

The process requires no power for heating the bath. Besides zinc has a tendency to sublime and in hot dip process, lot of zinc gets wasted due to sublimation. Hence cold dip process proves ultimately cheaper and better.

By electroplating: This process is used only for depositing a layer of zinc on intricately shaped items. It is not a popular process for mass production. The basic principle of zinc electroplating is to use an electrolyte made by dissolving zinc chloride, zinc sulphate, ammonium chloride and ammonium sulphate in distilled water. The zinc metal is used as anode and the article to be plated is used as cathode. Upon using a suitable low voltage and direct current, zinc gets deposited on the cathode.

ELECTROPLATING PROCESS

Principle of electroplating process: In the process of electroplating, a thin layer of a metal is deposited on another metal part with the object of corrosion prevention, or to ensure that the electroplated part looks nice and aesthetic. The part is usually electroplated with gold, silver, chromium or nickel because these platings look nice and do not tarnish.

The principle of electroplating is simple. If two electrodes are immersed partially in a suitable electrolyte and a direct current is passed by joining the two electrodes in an external circuit, the metal from the anode gets transferred through electrolyte-action on the cathode. A simple arrangement for electroplating is shown in Fig. 4.4.

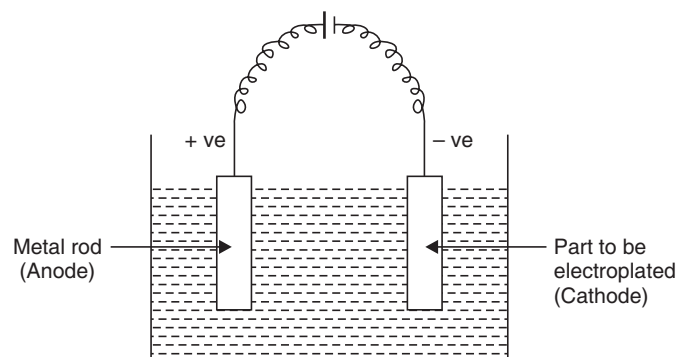

Fig. 4.4 Electroplating process

Electroplating is a metal deposition process. The amount of metal deposited can be calculated easily, it is remembered that 96500 coulombs of electrical charge (1 coulomb = 1 amp current \times 1 second) deposits one electrochemical equivalent of the substance at the electrode, irrespective of what the substance is. Electrochemical equivalent of a substance is equal to

$$\frac{\text{Atomic weight of the substance}}{\text{Valency}} \text{ (gms)}$$

For example, if copper is being deposited from CuSO_4 solution, electrochemical equivalent of copper is atomic weight of copper \div 2 (valency of copper). Atomic weight of copper is 63.5, and its equivalent will be = 31.75 gms.

FARADAY'S LAWS OF ELECTROLYSIS

The process of electrolysis or electroplating is governed by two laws called Faraday's laws of electrolysis. These laws are:

First law: The amount of substance liberated (or deposited) at an electrode during electrolysis is directly proportional to the total electrical charge passed in the electrolyte.

Second law: When the same quantity of electric charge is passed through different electrolytes connected in series, the masses of substances liberated (or deposited) at the electrodes are directly proportional to their electrochemical equivalent weights.

The net result of these two laws is that 96500 coulombs of electric charge will release or deposit one electrochemical equivalent in grams (called one gram equivalent) of the substance concerned. A numerical will make this clear. An electric current is passed through two cells connected in series and containing CuSO_4 and AgNO_3 solutions. The masses of copper and silver deposited are 0.424 gm and 1.44 gms respectively. Find the equivalent mass of silver, if that of copper is 31.75.

According to Faraday's second law, (since cells are connected in series)

$$1.44 : 0.424 = \frac{\text{equivalent mass of silver}}{\text{equivalent mass of copper}}$$

$$\therefore \text{Equivalent mass of silver} = \frac{1.44}{0.424} \times 31.75 = \mathbf{107.8}.$$

QUESTIONS

1. Describe, step by step, manufacture of a component by powder metallurgy process.
2. Why is galvanising done? Describe the "hot-dip" process of galvanising a steel sheet.
3. What is injection moulding? Describe the process briefly.
4. What is the object of electroplating? How is it done?
5. State Faraday's laws of electrolysis. What is electrochemical equivalent?
6. What is blow moulding process? What kind of products are made by this process?

Objective Type Questions

UNIT IV MISCELLANEOUS TOPICS

Pick out the most appropriate option:

- In paleolithic times, man made tools of
 - rough stone
 - polished stone
 - timber
 - metal.
- Hittites are credited with discovering
 - Gold
 - Copper
 - Iron
 - Glass.
- A good location for a factory should be governed by
 - availability of water
 - proximity to a city
 - availability of power
 - all of these.
- The disadvantage of 'line' layout is
 - breakdown of one machine stops the functioning of entire line
 - some high capacity machines remain idle for part of the time
 - supervision is difficult
 - all of these.
- Hard woods are superior to soft woods because
 - they are heavier and stronger
 - they are more durable
 - they retain their sizes over period of time
 - all of the above.
- What is a green compact?
 - Rough shape produced by forging
 - A casting made in green sand

- (c) A semifinished component made by powder metallurgy process
(d) All of the above.
7. What is galvanising?
(a) Tin plating
(b) Coating with zinc
(c) Coating with a corrosion resistant material
(d) None of the above.
8. In electroplating, the object to be electroplated acts as
(a) anode (b) cathode
(c) electrode (d) all of these.
9. Plastic components are manufactured by
(a) forging process (b) moulding process
(c) drawing process (d) none of these.
10. In what category of material will you classify R.C.C.?
(a) Ceramic (b) Composite
(c) Refractory (d) Plastic.

Indicate, if following statements are True or False:

11. Manufacturing is the key to socio-economic development.
12. Combination layout is a combination of product and group layouts.
13. By increasing production, productivity also increases.
14. Plywood is made by gluing together veneers of wood.
15. Ceramics have good dielectric properties.
16. Bakelite is thermoplastic material.
17. Vulcanising is a process associated with polymers.
18. Sintering is a process associated with powder-metallurgy process.
19. Fibre reinforced plastic is a composite material.
20. Fibres can be made from graphite.

ANSWERS

- | | | | | |
|--------|--------|--------|--------|---------|
| 1. (a) | 2. (c) | 3. (d) | 4. (d) | 5. (d) |
| 6. (c) | 7. (b) | 8. (b) | 9. (b) | 10. (b) |
| 11. T | 12. F | 13. F | 14. T | 15. T |
| 16. F | 17. F | 18. T | 19. T | 20. T |

**This page
intentionally left
blank**

Question Paper

B.Tech. (Sem. I) Examination, 2008-09

(Only for the candidates admitted/readmitted in the session 2008–09)

Time : 2 hours]

[Total Marks : 50

Note: Be precise and scientific in writing.

SECTION A

Attempt **all** the questions:

1. This section-contains **10** questions. (Objective/fill in the blanks types). Choose/Fill the correct answer.
 - (a) Manufacturing is the process of converting raw material into
 - (b) The ductility of a piece of chalk is
 - (c) The % of carbon in medium carbon steel varies
 - (i) Less than 0.20
 - (ii) 0.10 to 0.30
 - (iii) 0.30 to 0.60
 - (iv) More than 0.60
 - (d) Stainless steel comes under the category of
 - (i) Non ferrous metal and alloy
 - (ii) Ferrous metal and alloy
 - (iii) Polymer
 - (iv) Composite
 - (e) Bronze is an alloy of
 - (i) Aluminium and zinc
 - (ii) Aluminium and nickel
 - (iii) Copper and tin
 - (iv) Copper and zinc
 - (f) Forging of metal is a
 - (i) Machining process
 - (ii) Welding process
 - (iii) Joining process
 - (iv) Metal forming process

- (g) Metal forming is the process in which
 - (i) Removal of metal takes place
 - (ii) Shaping of metal by forces applied through various dies and tools
 - (iii) Some additional materials are joined to the raw material
 - (iv) Material addition, through melting and pouring
- (h) Blow holes are the common defects found in
 - (i) welding
 - (ii) machining
 - (iii) forming
 - (iv) casting
- (i) Finishing is the operation best done by
 - (i) Milling machine
 - (ii) Shaper machine
 - (iii) Planer machine
 - (iv) Grinding
- (j) Swing is the one of specifications of
 - (i) lathe machine
 - (ii) shaper machine
 - (iii) drilling machine
 - (iv) grinding machine

SECTION B

2. Attempt any **three** questions. All questions carry **equal** marks:

- (a) Explain the following terms:
 - (i) Ductility
 - (ii) Stiffness
 - (iii) Brittleness
 - (iv) Fatigue
 - (v) Malleability
- (b) Draw rough sketch of the stress strain diagrams of
 - (i) Ductile material, and
 - (ii) Brittle materialBriefly explain, what do you understand by Toughness.
- (c) Explain
 - (i) Mould, and
 - (ii) PatternDescribe the two important pattern allowances.

- (d) With the help of sketch, explain the basic components of lathe machine and various operations performed on it.
- (e) With the help of sketch, define the following operations:
 - (i) Forging
 - (ii) Rolling
 - (iii) Drawing
 - (iv) Extrusion.

SECTION C

Note: Attempt any **four** questions. **All** questions carry **equal** marks.

- 3. Answer any **one** part of the following:
 - (a) Based on % of carbon, classify carbon steels. How do stainless steel become stainless?
 - (b) What are the major uses of copper? What are the alloying elements in brass and bronze, respectively and also write its uses.
- 4. Answer any **one** part of the following:
 - (a) Differentiate between hot and cold working of metals. Bring out the advantages and disadvantages of each of these techniques. Explain with neat sketch the rolling of steel bar.
 - (b) Define the following terms with sketch as used in sand casting:
 - (i) Core
 - (ii) Core-Prints
 - (iii) Sprue
 - (iv) Runner
 - (v) Riser
- 5. Answer any **one** part of the following:
 - (a) With the help of schematic sketch, describe the basic working principle and important parts of shaper machine. Also describe the difference in operation between shaper and planer.
 - (b) Explain fusion as it relates to welding operations. How will you classify the welding processes? Explain the features of neutral, reducing, and oxidizing flames.
- 6. Answer any **one** part of the following:
 - (a) Discuss the role and importance of materials and manufacturing for the growth of any nation. Explain the production and productivity.
 - (b) Explain briefly the following with suitable examples:
 - (i) Electroplating
 - (ii) Galvanizing
 - (iii) Plant layout
 - (iv) Ceramics.